

UC-NRLF



\$B 661 962

LIBRARY
UNIVERSITY OF CALIFORNIA
DAVIS





Digitized by the Internet Archive
in 2007 with funding from
Microsoft Corporation





THE
DICTIONARY
of the
ARTS, SCIENCES,
AND
MANUFACTURES,

illustrated with
ELEVEN HUNDRED ENGRAVINGS.

BY
G. FRANCIS, F.R.S.

*Author of The Analysis of British Coins,
The Little English Florist, The Grammar of Botany &c.*

LONDON:
W. BRITTON, 11, PATERNOSTER ROW.
1846.



PREFACE.

THE nature and extent of this Work will be better understood by reference to its pages, than by any remarks which can be made in a Preface. The following previously-circulated Address will, however, show the object of the author in its preparation :—

“ Those who are accustomed to attend philosophical lectures, or to read scientific books, must be aware how much valuable information is lost if they do not properly understand the scientific language, and know somewhat of the construction of the instruments used in illustration. The lecturer cannot stop at all times to explain these matters, and there is no book sufficiently cheap, modern, condensed, and illustrated, to communicate the information wanted ; thus the student necessarily remains ignorant, though with the strongest thirst for knowledge. The general reader too, who may not desire to know the laws of natural philosophy, yet may admire those of art ; machinery, architecture, or painting, may employ his attention, and if he should be without a director to explain the different parts, and the technical terms, here, as in the former instance, much valuable time will be lost, and dissatisfaction, often disgust, succeed. Even supposing a person care for none of these things, yet his daily intercourse with the world will often thrust upon his attention some portion of the scientific improvements or discoveries which are yearly occurring, which the usual Dictionaries take no cognizance of, and which the voluminous Encyclopædias discuss at a greater length than he desires, even should he possess one of them—which, unless a rich man, probably he will not.

“ The attention of the author of this ‘ Dictionary of Arts and Sciences ’ has been directed to three objects.—The first, to explain briefly, but plainly, all the terms used in architecture, civil engineering, practical mechanics, manufacturing processes, the mathematics, the fine arts, and the experimental sciences. The second, to give the origin, properties, and application of all chemical substances ; and the third, to record and describe all the apparatus and machines employed in natural philosophy ; and also those numerous inventions and contrivances of a mechanical nature, which our periodicals and galleries of art abound with, but which are known comparatively to a very few persons, though often of the most essential value to the community ;” illustrating each article with wood-cuts, wherever such could in any way whatever lead to the better understanding of the subject.

It will be readily believed, that the above has been a most difficult task, involving care, patience, and assiduity, especially as the author was his own draughtsman ; he trusts, however, that his readers will give him the credit of carrying out, to the utmost of his power, the original, and it is to be hoped, useful design.

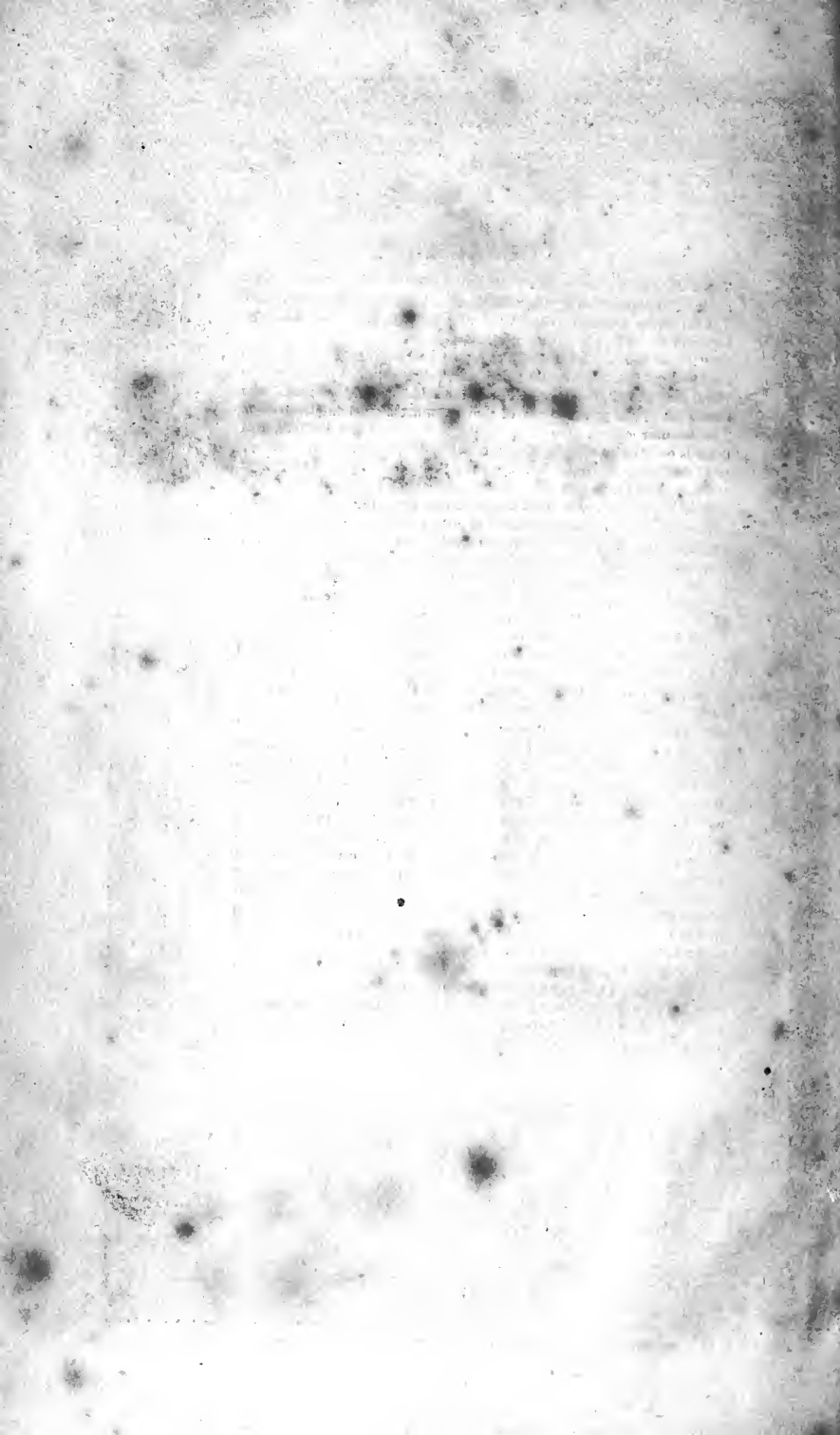



Dictionary

OF

Arts and Sciences.

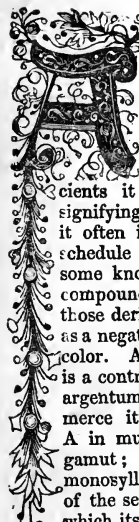

 The first letter in all alphabets, except that of the Abyssinian language. In English it has four sounds, exemplified in water, father, paper, and fancy. Among the ancients it was a numeral; in Greek signifying 1; in Latin 500. With us it often indicates priority, as we say schedule A. In algebra it is put for some known quantity. In numerous compound scientific words, particularly those derived from the Greek, it is used as a negative, thus *achromatic*, without color. A, in inscriptions and on coins, is a contraction of Augustus, absolvo, argentum, annos, &c. In modern commerce it implies accepted and acre. A in music is the sixth note of the gamut; in singing representing the monosyllable *la*. It is the open note of the second string of the violin, by which its other strings are tuned and regulated. A with a figure annexed, pre-ceding a piece of music, indicates the number of voices it is intended for, as A 2, for two voices, &c.

ABACISCVS. In ancient architecture one of the tiles or compartments of an ornamental pavement. Not to be confounded with the tesserae or cubical blocks used by the ancients in tessellated pavements; but

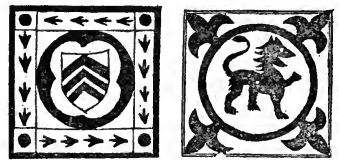
more resembling the *quarries* of modern use, and of which the following may convey an idea. (See *Quarry, Tessera, and Pavement.*)

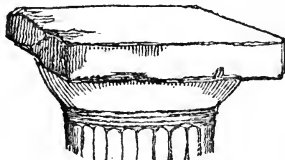

ABACVS. The tablet or cap which covers the top of a column.



The term, though of Greek origin, is equally applied to the blocks, whether plain or sculptured, which crown the capitals of ancient Indian and Egyptian buildings, although often so different in shape from the Greek.



In the Greek Doric order the abacus is square and unornamented. In the Greek Ionic it is thin, square, or rectangular, with an ovolo moulding around it. In the Corinthian it has hollowed sides, truncated angles, and a rosette or other ornament in the centre of each side.



In the Roman Doric, the Tuscan, and Composite, the abacus is shaped as follows, varying in a very slight degree from the Greek examples.



In Gothic architecture it is extremely varied. In the Norman and Saxon styles the abacus was mostly square, with the lower angle chamfered off. In the early English buildings round abaci were common. In the later and more ornamented styles, a variety of angular forms were introduced.



ABACUS. Among the Romans a counting table. At first merely a tray sprinkled with sand, upon which calculations were made. Afterwards a frame with transverse wires, upon which beads were strung, and which from their position had a certain value assigned to them; one wire denoting units, the next tens, and so on. 1836 would be indicated as follows:—

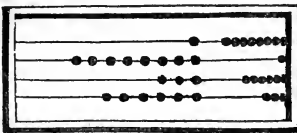

ABAMURUS. A buttress, or second wall built to strengthen another.

ABARTAMEN. An old name for lead.

ABATIS, or ABBATIS. Trees felled and laid side by side, with their boughs outwards, to impede the progress of an enemy.

ABBREVIATE FRACTIONS. Compound fractions, when reduced to simple ones, are thus called.

ABBREVIATION. The shortening of a word, either for the sake of saving time and space, as hhd. hoghead, or for secrecy. (See *Contraction*, *Hieroglyphic*, and *Symbol*.)

ABBEVOIR, or ABBREVOIR. The joint between two of the stones of an arch, and usually filled up with fine mortar.

ABB WOOL. Among clothiers signifies the warp or longitudinal fibres of a woven fabric.

ABERRATION is the wandering of any body from the path in which it is expected to move. In astronomy it is applied to light, in its passage from one of the heavenly bodies to another. For example, the apparent place of a star differs from the true, because light not being instantaneous in its progress, the earth will have moved so far in its orbit, while the particles of light which renders the star visible is passing to the eye; and hence the telescope through which we view the luminary must be directed forwards, on a similar principle as the fowler points his gun before the bird which he would shoot in its flight.

ABERRATION, Spherical. The intention of spherical lenses, or of concave mirrors, is that the rays of light should in the former case be refracted, and in the latter reflected, so as to converge, and meet in a single point, or *focus*. In practice, the rays are generally found to deviate from that point, and this deviation is called the spherical aberration of the lens or mirror. These aberrations arise from two causes—from the form of curvature of the lens or of the reflector, and from the different refrangibility of the rays of light.

ABLACTATION. That kind of grafting trees in which the scion or graft is not separated from the old stock till fully incorporated with the new.

ABRASION. Wearing away by friction; also the crumbling of earth by frost.

ABRAXAS STONES. A name applied to a variety of gems that exhibit enigmatical compositions, strange words in foreign characters, &c. They were so called, because the more ancient of them, and which often represented the human body, with the head of a cock and the feet of a reptile, have the Greek word, *abraxas*, engraved upon them. Such stones are supposed to have been amulets or talismans.

ABRIDGING. In algebra the reducing a compound equation or quantity to a more simple form of expression.

ABSCISSA. (See *Hyperbola*.)

ABSOLUTE. Independent of any thing else; unconditional.

ABSOLUTE EQUATION. (See *Equation*.)

ABSOLUTE NUMBER. In algebra that term in an equation which is completely known, and which is equal to all the other terms taken together. In the equation $x + 4y + 2 = 30$. The 30 is the absolute number.

ABSORBED. In painting is when the oil is so soaked in, that the colors appear dead or flattened. Synonymous with chilled or sucked in.

ABSORBENT. Sucking up, or imbibing. Thus alumine is an absorbent earth; flint is not so; sulphuric acid is a liquid rapidly absorbent of water; potassium absorbent of

oxygen, &c. In painting, picture grounds are thus called when they have the power of absorbing the oil, &c., so much that the colors shall dry quickly; such as distemper grounds.

ABSORBING CASCADE. An instrument invented by Mr. Clement, for the more perfect absorption of aeriform fluids by water.

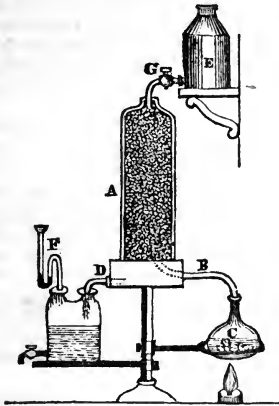

A is a cylindrical vessel, filled with glass beads, and water trickles into it from the reservoir E, through the cock G. In descending between the glass it meets with the gas coming from C, through B, becomes thereby charged with gas, and runs away for use through D into any vessel put to receive it. F is a safety valve. Mr. Clement calculates the absorbent power of this apparatus to be more than 300 times greater than the usual machines: it has been used chiefly for the absorption of chlorine. A similar apparatus, called the productive cascade, has also been contrived by Mr. Clement, in which gases may be formed: for example, fill A with oxide of manganese, in large pieces. C partly with sulphuric acid and salt. Let water trickle through A, and apply heat to C, when the manganese and salt will be decomposed, and chlorine pass off through a pipe near the top of A.

ABSORPTION. The act of sucking up. Dry earth absorbs moisture, so do the spongioles of roots, and various membranes of the animal body; water absorbs certain gases, &c.

ABSORPTIONS of the Earth. A term used by Kircher and others, for the sinking in of large tracts of land by subterraneous commotion, and many other circumstances.

ABSTRACT SCIENCES, IDEAS, NUMBERS, &c. Those which are independent of others, and are not to be altered by time or circumstance;—thus algebra, geometry, arithmetic, fluxions, &c., are abstract or pure

mathematics, considered in themselves; but when applied to the explanation of natural laws, or physical facts, they cease to be abstract and become *mixed*. The number 3 is abstract when not connected with a noun, but in union with an object, as 3 books, 3 pages, it is no longer abstract.

ABSURD. A method of mathematically proving a proposition, by showing that it cannot be otherwise than stated; so that even to suppose it different would be absurd.

ABUNDANT NUMBER, is that the aliquot parts of which, when added together, are more than the number itself; thus 12 is an abundant number, because 1, 2, 3, 4, 6, its aliquot parts make 16.

ABUTMENT, or BUTMENT. The solid supports at the end of a bridge or arch, also synonymous with buttress. In carpentry, the joint when timbers are framed at right angles one with the other. In engineering, it is any part from which a moving power arises, or against which it stops; thus the ends of the cylinder of a steam-engine, where the motion of the piston rod begins and stops, are its abutments.

ABUTMENT ARCHES. The two end arches of a bridge.

ACACIA. Something resembling a bag or roll, often found on the medals of the Greek and Roman emperors.

ACACIA GUM. The same as gum arabic, which is produced from different species of the acacia tree.

ACADEMY FIGURE. A drawing in light and shade, made after a living model, regulated by the rules and orders of an academy.

ACANTHUS. In architecture, an ornament which resembles the leaves of a plant so called. It is used in the capitals of the Corinthian and Composite orders, and is said to have been introduced into the former by Callimachus, an Athenian architect, who was struck with the beauty of the leaves surrounding a basket, which, covered with a tile, had been left so near the plant that the leaves had grown over it.



The preceding cut shows the plant in its growing state; the following represents the front and side views of the leaf as an architectural ornament.

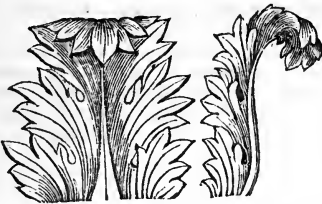

ACCELERATION. An increase in the rapidity of a moving body.

ACCELERATION, of a Star. Owing to the motion of the earth in its orbit, the stars come to the meridian $3' 56''$ of time earlier each succeeding day, which is their acceleration.

ACCELERATION, of a Planet, is when its real diurnal motion exceeds its mean diurnal motion; this arises from the greater rapidity of the planet's motion in one part of its orbit to that in the other.

ACCELERATION, of the Moon. An increased mean motion of the moon, as compared with the diurnal motion of the earth, now and at former distant times; the cause of this is unknown, and the extent of it about $9'$ in a century.

ACCELERATED MOTION. A rapidity of motion constantly increasing, like that of a stone falling from an eminence. The velocity of a falling body increases each second in the arithmetical ratio of 1, 3, 5, 7, &c., and the whole space passed over in the geometrical ratio of squares, 1, 4, 9, 16, &c. Thus a stone falling passes over 16 feet in the first second; 3 times 16 in the second; 5 times 16 in the third; while the distance it has fallen altogether is 16 feet the first second; 4 times this altogether at the end of the second; 9 times 16 at the end of the third; and so on.

ACCELERATED FORCE. The increased force which a body exerts in consequence of its increased motion; better to say, accumulated force.

ACCESSES. External passages or corridors.

ACCESSORY. Something added to the principal design, as the subordinate parts and objects in a picture, the embellishments of sculptured architecture, &c.

ACCIDENTAL. Such parts of a picture or sculpture as are not necessarily present or non-essential.

ACCIDENTAL COLORS. If we look intently with one eye upon any colored spot, as, for example, a wafer placed upon a sheet of white paper, and immediately afterwards turn the same eye to another part of the paper, we

shall see a similar spot, but of a different color. Thus if the wafer be red, the seeming spot will be green; if purple, the spot will be orange; and so on for other colors. The corresponding spots are accidental colors or ocular spectra.

ACCIDENTAL LIGHTS, in a Picture, are such as arise from casual circumstances.

ACCIDENTAL POINT. In perspective is the point in which a right line drawn from the eye, parallel to another right line, cuts the picture, as in the following: F is the accidental point. EF being parallel to AB.

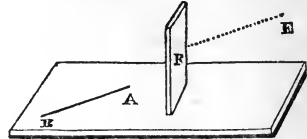

ACCLIMATISE. To accustom animals and plants to a climate new to them.

ACCORDION. A musical instrument; the sound of which is produced by the vibration of metallic springs, occasioned by a current of air rushing from a bellows, where it is accumulated, through valves attached to the notes, and which are opened by the fingers of the musician.

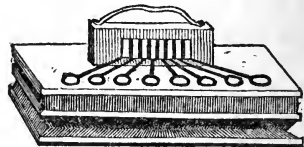

ACCOMPANIMENT. Any music played or sung for the purpose of increasing the effect of the principal melody.

ACERATE. A salt formed with aceric acid and an alkaline or other base.

ACERBITY. A sour roughness of taste, such as that of unripe fruit.

ACERIC ACID. Discovered by Scheren in the juice of the maple, in the state of acerate of lime.

ACESCENT. Substances are so called which spontaneously enter into the acetous fermentation, as beer, wine, over-ripe fruit, &c.

ACETATES. Neutral salts, composed of acetic acid, and an alkali or metal. The acetates are, with the exception of two or three, soluble in water, decomposed by heat, and by sulphuric acid; and often, when in solution, by exposure to the air. The chief acetates used in the arts are those of manganese, iron, copper, lead, and alumine.

ACETATE of Manganese is prepared for the use of calico printers by mixing sulphate of manganese with acetate of lime. It forms transparent, pale red rhomboidal tables, soluble in water and alcohol.

ACETATE of Peroxyde of Iron, may be obtained by digesting turnings and clippings of iron in acetic acid, or by mixing acetate of lead with sulphate of iron. It forms a deep reddish brown solution, not capable of crystallization. It is used by dyers and calico printers.

ACETATE of Copper, or *Crystallized Verdigris*. Dissolve common verdigris in acetic acid, and evaporate till a pellicle forms on the surface of the solution; and set aside to crystallize.

DI-ACETATE of Copper, or *Common Verdigris*, is prepared by exposing sheets of copper to the action of acetic acid, or its fumes. In France it is made by the acid produced by the fermentation of grape stalks, husks, &c.

ACETATE of Lead, *Sugar of Lead*, is much used as a drier by the painter, and in various operations connected with dyeing and calico printing. It is made by exposing plates of lead to the fumes of vinegar, or pyroligneous acid. The white powder thus produced is dissolved in excess of acid, and crystallized. It may also be made from litharge, or from the carbonate of lead, (the common white lead,) by dissolving either of them in acetic acid.

ACETATE of Alumine. So extensively used by dyers and calico printers as a mordant for a great variety of colors. About 3 lbs. of alum are dissolved in 8 gallons of water, and 1½ lb. of sugar of lead stirred in it. A copious formation of sulphate of lead subsides, and the clear liquid is a solution of the acetate of alumina.

ACETIC ACID. The acid which exists in vinegar. It is the result of the acetous fermentation, and may be procured from most animal and vegetable products, as fruit, sugar, milk, &c., whether such materials may have been subjected to the vinous fermentation or not; thus we say, sour wine, sour beer, sour milk, &c., the acidity of which arises from the presence of this acid. It may also be procured by the distillation of green wood, called then *Wood Vinegar*, or *Pyroligneous Acid*, (which see.)

ACETOMETER. An instrument for ascertaining the strength or specific gravity of acids. It consists of a globe of about 3 inches diameter, having a little ball beneath, and a graduated stem above; the upper part of the stem being furnished with a cup to hold the requisite weights. It differs in no respects from the hydrometer, except in the material of which it is made, and in the method of graduation.

ACETONE. A new name for pyro-acetic spirit. A combustible, colorless, strong smelling, acrid liquid, procured by the double distillation of the acetates. It is used as a cheap solvent for the gums and resins required in hat-making.

ACETOUS. Like, or belonging to vinegar.

ACHARD'S PYROMETER consists of a ball and tube of semi-transparent porcelain, highly baked, containing a fusible alloy of 2 parts bismuth, 1 of lead, and 1 of tin. In the temperature of the air this remains solid in the tube; but becomes fluid about the boiling point of water; then as a fluid expands by increase of temperature; and its expansion being seen through the translucent tube, which is divided into equal parts or degrees, it becomes an indication of the temperature applied to the ball.

ACHELAR OR ASHLAR. Hewn stone used for the facings of walls.

ACHROMATIC. Without color. Those optical instruments and lenses which suffer the rays of light to pass through them, without decomposition, are called achromatic. White light consists of rays of various colors, red, blue, and yellow; these rays are of different degrees of refrangibility, and when light passes through common glasses, thick and imperfect single lenses, and all such media as do not make proper allowance for these differences, it becomes decomposed, and instead of remaining white is seen in its different colors, if to be viewed at a distance, as in a camera obscura, solar microscope, &c.; or if seen through, or at the axis, it is ill defined and nebulous. It may be understood by the following diagram:—Suppose A A to represent rays of light coming from

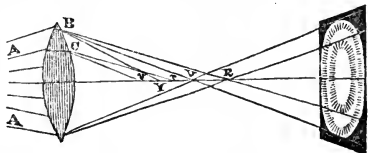

a distant object. Striking the lens B, each ray becomes divided into its three colors. The red will reach the axis at R; the violet at V; and the yellow at Y, instead of at the same point. The ray of light C, being nearer the centre of the lens, will be refracted differently—the red ray reaching to *r*, and the violet to *v*. At this part of the axis, therefore, there will be a confusion of tints, and if the red and blue rays be continued beyond the axis, as on to a screen, they will appear upon it in their proper colors.

ACHROMATIC EYE PIECE. An arrangement of lenses made so as to correct the chromatic and spherical aberration; that is, to cause the rays of light to be so refracted as to meet in one exact point. This is produced by a combination of lenses, such as the following. It may be understood by the next diagram, that the red part of the ray of light, A B, will meet the axis in R, and the violet in V, provided there were no other lens;

but this interposing, the red ray is refracted to C, and so is the violet ray, and thus the



effect of the one lens is to counteract the chromatism of the other.

ACHROMATISM OF THE EYE. The power which the eye has of viewing objects with distinctness, and therefore without decomposing light into its component rays—an effect which in artificial optical instruments is produced by a series of lenses.

ACICULAR. Needle-shaped. Many leaves, and also the crystals of some of the salts and minerals are of this form.

ACIDS. An extensive class of chemical substances; the properties of which are to combine in certain proportions with the alkalies in solution, and with most of the metallic oxydes, forming by such union neutral salts. They redden vegetable blue colors, and have mostly a sour taste. Some are derived from minerals, others from vegetables, and others from animals. Acids arise in nearly all instances from the union of their base with oxygen; the greater or less relative proportion of which regulates the peculiar properties of the acid. Such as are of the least degree of oxidation; that is, such as have but a small proportion of oxygen, end in *ous*. Those containing a large quantity end in *ic*—as sulphurous and sulphuric, both consist of sulphur and oxygen; but the sulphurous acid, with the same quantity of sulphur, contains 2 proportions of oxygen, sulphuric 3 proportions. A diminution of oxygen in either case forms a hypo-acid, as hypo-sulphurous acid consists of 2 parts sulphur and 2 oxygen; hypo-sulphuric acid of 2 parts sulphur and 5 oxygen. A few acids derive their acid properties from chlorine, and not from oxygen; as muriatic, or as it is now called, hydro-chloric acid. There are not above 20 acids used in the arts, though more than 220 are described in "Brande's Chemistry." The whole will be found under their respective names.

ACIDS, Artificial. Acids are so called when formed by the mixture of other acids. Thus, nitro-chloric acid is formed by mixing together the nitric and chloric acids. They are mostly a union of nitric acid with some vegetable principle, and formed by boiling that principle or ingredient in strong nitric acid. (See *Carbazotic Acid*, which is of this kind.)

ACIDS, Fatty. Such acids as are formed by reducing an oleaginous or fatty body to soap, by means of alkali; then adding alcohol

a neutral salt is separated, composed of the alkali used, and the fatty acid. Of this nature, and thus formed, are the stearic, margaric, oleic, phocenic, buturic acids, &c.

ACIDIFIABLE. Capable of being converted into an acid. Such substances are called *radicals*, or *bases*.

ACIDULE. A name given by the French chemists to such salts as have an excess of acid; such as supertartrate of potass.

ACIDUM ÆREUM. An old name for carbonic acid gas.

ACONITA. A poisonous alkaloid, extracted from the aconitum napellus, or monk's-hood.

ACOUSTICS. That branch of natural philosophy which treats of the nature of sound, and the laws of its production and propagation. It, therefore, explains the cause of echoes, the reverberations of thunder, and of artillery, the tone and mode of action of musical instruments, the theory of harmonics, &c.

ACRE. A measure of land, containing 4 square roods, or 160 perches. The English acre of land contains 4,840 square yards; the Scotch acre is nearly a quarter more; the Irish acre more than half more; the Welch nearly twice the English; the number of acres of land in England are 46,080,000.

ACROGRAPHY. The art of producing blocks in relief for the purpose of printing from along with type, and thus to supersede wood engraving. The method is at present kept a secret by the inventor, Mr. Schönberg, of Hatton Garden.

ACRONICAL. Said of a star or planet when opposite the sun; that is, which rises when the sun sets, and sets when the sun rises.

ACROSTIC. A poem of which the first, and sometimes the last, letters form a word or sentence.

ACROTERRIONS. The small pedestals upon the ends or summit of a pediment, as well as the statues which they sometimes support.



Also, the pinnacles, buttresses, or other divisions between the compartments of balustrading, along the attics of a building, &c.

ACROPOLIS. The fortress or citadel of Athens, which derived its name from standing on an eminence.

ACROSPIRE. The plumule; that is, the first root that a seed makes when germinating. In the process of malting an acrospire is seen on every grain of barley after steeping in the cistern.

ACTING POINT. That part of a machine to which the power is first applied; as the acting point of a hand-mill is the winch by which it is turned; of a wind-mill, the sails are the acting points; of a steam-engine, the piston of the steam cylinder.

ACTION AND REACTION. Action is the motion which one body produces or endeavours to produce in another; and reaction the resistance offered by the second body. Action is therefore synonymous with force, and reaction with resistance.

ACTION, Chemical. The effect produced by one body on another, so that one or both of them are altered in their properties by the union or disunion. Thus an acid and an alkali have a chemical action upon each other, because they unite and form a salt, which is neither acid nor alkaline.

ACTION, Electrical, Galvanic, and Magnetic. The power exerted by the electrical or magnetic fluid of any body when put in circulation, over the electrical or magnetic fluid of any other body, near or in contact with it.

ACTION, Mechanical. The effect of bodies over each other's motion, such bodies remaining unaltered by their respective approach or union. Thus one ball striking another is a mechanical action; so is also a horse drawing a cart, &c. A cannon acquires its propelling power by the chemical action of fire and gunpowder producing suddenly a quantity of gas. The mechanical action or force of this drives out the ball, and the mechanical action of the air stops its flight, while the power of gravitation, which is also a mechanical action, brings it to the ground.

ACTION, Mutual. When two or more bodies conduce to occasion the same effect.

ACTIVE FORCE. (See *Force*.)

ACUMINATE. Lengthened out so as to end in a point, as a pinnacle, a leaf, a spindle, &c.

ACUTE ANGLE. (See *Angle*.)

ADAGIO, in Music. A slow time, generally applied to music which is to be played with grace and embellishment.

ADAPTER. A glass tube open at both ends, used to connect a retort with its receiver when the neck of the former is not long enough.



ADDITION. The adding or blending one thing to another. A rule in arithmetic, whereby the sum of two or more numbers is found.

ADDITIONAL KEYS. Those keys of a piano-forte which lie either above or below the former compass of the instrument. These are generally four or six notes above F in alt, and three notes below double F.

ADHESION is the union of the surfaces of

bodies together, and is measured by the force which is requisite to separate them again. Adhesion may be either natural or artificial. It is not to be confounded with cohesion, or the power by which the particles of bodies unite with each other, forming a solid mass; nor yet with gravitation, which is merely the weight of one body upon another; nor yet the pressure of the atmosphere upon an external surface, when the air is removed from beneath it, as is seen in the Magdeburg hemispheres, and in the school-boy's leathern sucker, but is rather an attraction or adhesion between different bodies. Thus we speak of the adhesion of clay to our feet, the adhesion of wax, oil, or paint, to our clothes, the adhesion of pieces of wood, glued or nailed together, &c. &c. The power or degree of strength with which bodies unite is called their force of adhesion. Mr. Bevan found that if a nail driven into Christiana deal required 170 lbs. to extract it, in green sycamore it required 312 lbs., in dry oak 507 lbs., in dry beech 667 lbs. A screw holds three times as strongly as a nail of similar length; and in most light timbers a nail driven across the grain holds with twice the force of one driven with the grain. In oak and elm there is not so much difference. Well-glued surfaces of dry ash holds with a force of 715 lbs. $\frac{7}{8}$ square inch, if the glue be new. Scotch fir 562 lbs. on the inch.

ADHESIVE SLATE. A soft, massive, yellowish grey slate, which splits easily, and adheres to the tongue, whence its name. It is found near Paris in the gypsum beds.

ADIPOCERE. A fatty, or rather soap-like substance, generated by dead bodies when buried in stagnant or in running water. In 1786-7, 1500 bodies, which were completely changed into this substance, were dug out of the cemetery of the Innocents, when it was found that adipocere was well adapted for the use of the candle maker and the soap boiler. It is white, hard, without scent, somewhat resembles wax, and burns with a clear bright flame.

ADIT. The entrance to a mine, if horizontal, and leading direct from the neighbouring county; vertical entrances to mines are shafts.

ADITUM. The whole interior of the ancient temples were so called, now it is applied only to the more sacred parts.

ADJECTIVE COLORS. Such as in dyeing will unite with the material to be dyed without a mordant.

ADJUTAGE. The butting or resting of one thing against another. (See *Adjutage*.)

ADOPTER. (See *Adapter*.)

ADULTERATION. The debasement of any article of produce or manufacture, by the introduction of inferior materials.

ADZE. A cutting tool, used by different artizans.

Æ. Many words, formerly beginning with this diphthong, being now spelt with E only, will be found under that letter.

ÆGINETIAN MARBLES. A collection of seventeen statues, obtained from the temple of Jupiter Panhellenicus, at Ægina, one of the most beautiful remains of Doric architecture. They were purchased by the king of Bavaria, in 1812, and the deficient parts afterwards restored by Thorwaldson. They are now exhibited in Munich, and are remarkable for their exact imitation of nature. This, indeed, is as strong a characteristic of the Æginetan style, as ideal grace is to the Attic of the time of Phidias.

ÆLLOPODES. The name given by its inventor to a pedomotic carriage, which was for some time exhibited in London, in 1839.

ÆOLEAN HARP. A stringed instrument, played by a current of wind issuing through a crevice or hole. It consists of a thin wooden box, with a hole at the top, and 10, 12, or 14 cat-gut strings across it; the 2 outer ones of which are like the fourth string of the violin—all the rest like the first string. It is usually adapted in length to fit a window, the lower sash of which is to be lifted up sufficient only for its insertion. It may be 6 inches wide, and $2\frac{1}{2}$ deep; the strings must be tuned so as to be in unison with each other; they are supported at each end by a bridge.



ÆOLEAN HARP, Meteorological. An instrument invented by M. Ventail, of Basle, which emits sounds during changes of weather. It consists of 15 iron wires, of different sizes, and 320 feet long each, stretched across a garden. It is said by the discoverer, that the sounds emitted are so loud that a concert could not be heard in the house, and that they resemble sometimes the hissing of water when about to boil; at other times the sound of an harmonicon, a chime, or an organ. The wires were inclined 20 or 30° with the horizon, and due north and south—not sounding in any other direction.

ÆOLIPILE. A ball or vessel in which water can be converted into steam, and which allowing the steam to escape by two opposite orifices, by pipes connected with it, communicates motion to the ball. It was invented by Hero, and is the origin of that mighty instrument, the steam engine.

A is a cauldron in which water is heated. The steam ascends through B and C into the ball D, escaping by the orifices E E; of course the ball must be supported in such a manner upon the pipes C D as to have

freedom of motion around them, as an axis, yet that this part shall be steam tight.

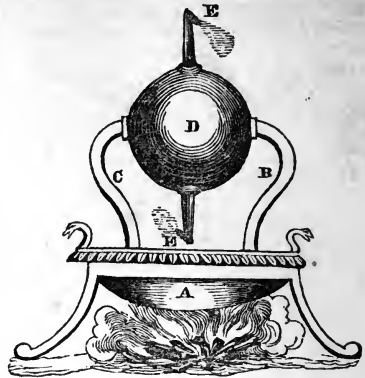

A philosophical toy is made under this name: it consists of a small ball of metal, with an exceedingly narrow tube and orifice—this ball is filled with spirits of wine. It is made to boil rapidly by a spirit lamp held beneath it. The steam of the spirit will of course rush out, sometimes to the distance of 2 or 3 feet, and this being set fire to produces a long and beautiful jet of fire. (See *Fire Cloud*.)



A ball of this description is sometimes mounted on four wheels, which bear also the spirit lamp. If the ball be filled with water, and this made to boil, the steam will, if directed into the air at the back of the carriage, by its counter-action, impel the whole along the table, forming the first and simplest steam loco-motive carriage.

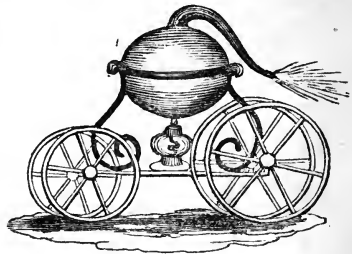

An instrument similar to the above, but on a large scale, is used occasionally as a bellows, to increase the draught of a steam-engine furnace; also the alcoholic blow-pipe is upon a similar construction.

ÆOLOPHON. A musical instrument, resembling a piano-forte in appearance, the

sound of which arises from the vibration of metallic springs, as in the seraphine.

ÆPINUS'S *Method of making Magnets* will be understood by the following diagram.

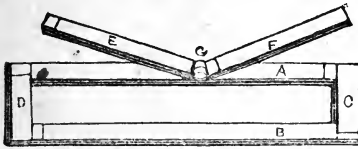

A B are two bars of steel which are to be magnetized. They are joined together at the ends by two hard steel already-made magnets C and D. Then two strong magnets E F are to be held one in each hand, at an obtuse angle with each other, and their lower ends placed on one of the steel bars—such ends being separated by a small piece of wood G. Then without separating E and F they are to be drawn backwards and forwards along the steel bars several times, when it will become magnetic. When the bar on one side is done, the other bar is to be magnetized in the same manner. It is said, that this method is best adapted to magnetise long and large bars, such as those used for batteries.

ÆOLUS. A small portable machine, invented by Mr. Field, for refreshing and changing the air of rooms, commonly called a ventilator, and fixed into a window instead of a pane of glass—its turning round producing the current of air required.

ÆRATED WATERS. Water impregnated with carbonic or some other gas. Water of this kind is commonly sold as soda water, though improperly so called. Many mineral springs are impregnated by different gases, that at Harrogate contains sulphuretted hydrogen. Water may be made to absorb numerous gases by the following, which from its inventor is called Nooth's apparatus.

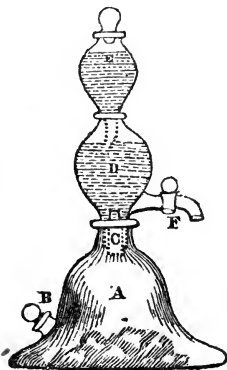

A D E are three glass vessels fitting into each other. The ingredients to make the gas are put by B into A. The gas passes the finely-perforated tube C into water previously placed in D. After a time it may be drawn off by the cock F.

The following apparatus is better adapted to aerate water, when large quantities are to be operated upon at once. A is a vessel from which chlorine, carbonic acid, or other gas is issuing. It passes to B, which is a bag loaded with a weight. C a cock, communicating from B to the cask D, which is half filled with water. The cock is so

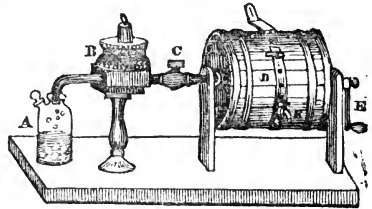

connected with C, as to allow the former to turn on its axis, without the joint becoming leaky; in order that it may be turned round by the handle occasionally throughout the process, to occasion the water to absorb a greater portion of gas; finally, the contents are drawn off at F, and a fresh supply poured in at the hole at the top of the barrel, which has a band and staple to keep it properly fixed. The absorbing cascade is also an excellent apparatus for the same purpose. (This see, as well as *Soda Water Fountain*.)

ÆRATION. Exposing soil to the air.

ÆRIAL ACID. An old name for carbonic acid gas.

ÆRIAL ELECTROMETER. De Luc when he had discovered the electrical instrument which bears his name, (*De Luc's Dry Pile*, which see,) observed, that its effects were much influenced by the state of the atmosphere; and therefore proposed it as an instrument to indicate aerial electrical changes, under the name of the aerial electrometer. The instrument has, however, never been thus applied.

ÆRIAL PERSPECTIVE is that which represents in pictures the weakening of tint in objects distant from the eye, whether relative to distance alone, or to the interposition of mist, clouds, &c.

ÆRIFORM BODIES or ÆRIFORM FLUIDS. Gaseous or resembling air.

ÆRODYNAMICS. A branch of mathematical philosophy, which treats of the powers and motions of elastic fluids, particularly the air. (See *Pneumatics*.)

ÆROGRAPHY, ÆROLOGY, or ÆROMETRY. Synonymous with pneumatics.

AEROLITES. Stones which fall from the atmosphere, called also meteorites or meteoric stones. They consist of iron with a small admixture of nickel. Their origin is not known; some persons suppose that they are cast from volcanoes in the moon, and coming within the influence of our attraction descend to the earth's surface.

AEROMETER. An instrument to ascertain the bulk of gases. A graduated tube furnished with a ball has a certain number of inches of gas passed into it. This is inverted in another tube, containing water or mercury of a certain degree of heat, and which raising the inclosed gas to the same degree, shows by its contraction or expansion the positive quantity of gas operated upon.

AERONAUTICS. AEROSTATION. The art of sailing through the air, as in a vessel at sea. The ancients speak of several aeronautic machines and automata, such as a flying pigeon made by Archytas, Medea's dragons, Juno's peacocks. &c; and also have some accounts of persons flying by means of wings attached to their shoulders. These are probably all fabulous; at any rate we are now enabled to navigate the air only by the aid of balloons, and even by these only to be driven where the wind may impel the machine. To the formation and management of balloons therefore the term is solely applied. (See *Balloon*.)

ÆRUGO. Oxyde of copper; also, verdigris.

ÆSCULINE. An alkaloid, lately discovered by M. Curzoneri in the bark of the horse chestnut. It is of no known use.

ÆSTHETICS. The science of sensations, or that which explains the cause of mental pain or pleasure, as derived from a contemplation of the works of nature and art.

ÆTHER. A thin, subtle fluid, supposed to fill all space beyond the limit of our atmosphere. Its existence is purely hypothetical, yet was maintained by most of the ancient philosophers, and by many of the moderns, among whom was Sir Isaac Newton. Some imagine it to be identical with the electric fluid. (See *Æther*.)

ÆTHRIOSCOPE is an instrument invented by Professor Leslie, on the principle of the differential thermometer, to indicate cold pulsations of the air, and which Dr. Brewster says is so delicate, that the liquor in the stem rises and falls with every passing cloud. The annexed cut. (No. 1.) is a representation of the original instrument. The cut, (No. 2,) is a simplification of it as proposed by Dr. Brewster. No. 1 consists of a metallic cup, of the shape given, and made of thin brass or silver, polished on the inside, and from 2 to 4 inches diameter. In the focus of this is placed one of the balls of a differen-

tial thermometer, the diameter of which ball is equal to one-third that of the cup. The other ball is bent so as to be as much as possible out of the way, that it may not be subject to a like influence, a lid of metal is put over the cup, and only removed when an experiment is to be made. The scale may extend 60 or 70° above zero, and about 15° below it.

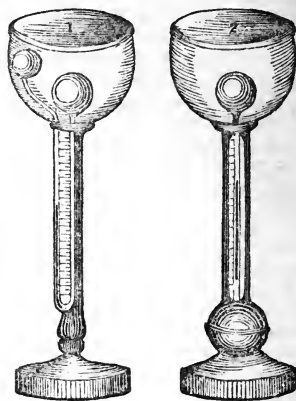

Fig. 2 is the same, as to the cup, cover, and sentient ball, but the tube is straight, and the second ball is inclosed in the foot of it. When used, the instrument is to be placed a few feet above the earth, that it may not be effected by terrestrial radiation. It may also be remarked, that this instrument would be of much more general application, if it were fixed upon an axis, or had a joint near the foot, that it might be directed to any particular part of the heavens, and not confined to a perpendicular impulse, as at present.

ÆTTITES. Eagle stones. A name given to certain round nodules of oxyde, or sulphuret of iron, which, being hollow and containing some concretions or detached particles, rattle upon being shaken.

ÆTHIOPS MINERAL. Mercury triturated with sulphur till it assumes a black color.

ÆTNA SALT. An impure sal ammoniac, found in the interstices of Mount Ætna and other volcanoes.

AFFECTED EQUATION. In algebra one in which the unknown quantities rise to two or more powers, as $x^2 + xy + y^2$. Also, sometimes used to signify those quantities which have co-efficients, as $2a$ or $3x$.

AFFINITY. A tendency of two bodies to unite chemically with each other, as an acid and an alkali unite and form a neutral salt, because they have an affinity for each other. Oil and water do not unite because they have no affinity.

AFFINITY, Elective, is where one body is formed by the decomposition of another. For example, dissolve some camphor in spirits of wine, they will unite; but add water the spirits of wine will let fall the camphor in a white powder, because it has a stronger or an elective affinity for the water.

AFFINITY, Compound, or Double Elective, is when two compounds are decomposed to form two others of a different nature. Thus, mix together a solution of bi-carbonate of potass, (pearl-ash,) and sulphate of iron, (green vitriol,) double decomposition will take place. Carbonate of iron will fall down, and the sulphate of potass be held in solution.

AFFIRMATIVE, or POSITIVE SIGN. The sign of addition +.

AFTER. In imitation of, as a person paints a picture in imitation of, or after Raphael, Corregio, &c.

AFTER GRASS. AFTER MATH. A second crop or mowing of grass.

AGARIC MINERAL, or MOUNTAIN MEAL. A light porous carbonate of lime, which lately has been found to consist wholly of the exuviae of fossil animalcules. It is abundant in Tuscany, and often there made into bricks, with the admixture of a certain portion of clay, which are, when baked, so light as to float in water.

AGATE. A silicious stone, of various colors, used for brooches, seals, snuff boxes, knife handles, &c. The following are varieties:—Ribbon agate, brecciated agate, fortification agate, mocha stone, moss agate, and oriental agate. Some specimens are of exquisite beauty and of a large size.

AGE, in Chronology, 100 years.

AGE, of the Moon. The time elapsed since the last new moon.

AGEDOITE. The same as asparagin.

AGENT. Any active cause, or power; as steam is said to be a powerful agent of motion.

AGGREGATED. When the parts of a mineral, or other body, are collected together in such a manner that they may be separated from each other by mechanical means. Granite is an aggregated rock, so is sandstone, pudding stone, &c.

AGRICULTURE. The art and science of cultivating the earth, so as to preserve and increase the natural fertility of the soil, either as applicable to the growth of food, timber, materials for manufactures, or the rearing and feeding of cattle.

AGRICULTURAL IMPLEMENTS. (See *Harrow, Plough*, and others, according to their names.)

AGREMORE. A name given to charcoal when in a state fit to be mixed with the other materials in the making of gunpowder.

ARGUILLE. An auger, adapted for boring through stone, used in blasting rocks with gunpowder

AILERON. Synonymous with starling.

AIR. The general term of the atmosphere, which see.

AIR, Inflammable. (See *Hydrogen*.)

AIR, Dephlogisticated. (See *Oxygen*.)

AIR, Vital. (See *Oxygen*.)

AIR, Fixed. Carbonic acid gas.

AIR, Phlogisticated. Nitrogen.

AIR, Mephitic. Nitrogen.

AIR BALLOON. A balloon, the buoyancy of which is produced by being filled with hydrogen gas, as those of common use, in distinction to a fire balloon. (See *Balloon*.)

AIR BEDS, CUSHIONS, &c. Bags of requisite size, formed of air-tight cloth, and inflated, when required for use, either by the lungs, or by a pair of bellows. They are light, soft or hard, according as they are more or less inflated, are without the enervating effect of a feather bed, and require no making.

AIR CHAMBER. Any vacuity in machinery, stoves, &c., where air is contained.

AIR DRAIN. An aperture through which cold air is descending.

AIR ESCAPE. A simple and ingenious contrivance for letting off the air from water pipes. When these are laid upon rising ground, the air will often collect in the higher part, and obstruct the progress of the water. To remedy this inconvenience, the air escape is used. A hollow ball is attached to the upper part of the pipe, in which a ball cock is placed, adjusted in such a way, that when any air collects in the pipes, it will ascend in the vessel, and by displacing the water, cause the ball to descend, and thus open the cock and allow the air to escape. No water, however, can follow it, for when that fluid rises to a certain height, the ball rises and shuts the cock.

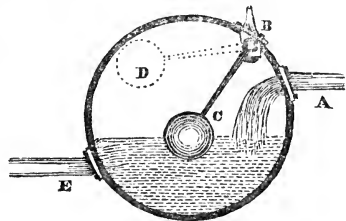

A is the pipe through which the water enters. B the cock, whence the pent air issues. C the ball cock, when the air is in abundance in the ball. D the ball cock, when the air has been let off. E the pipe to carry off the water.

AIR FLUE. A tube in which heated air is made to pass rapidly from a stove, in order to warm distant apartments, &c.

AIR GUN. An instrument from which the bullet is projected by condensed air, instead

of gunpowder. A resembles a common fowling piece, with stock, barrel, ram-rod, lock, and trigger. B is a valve, opening upwards when the hammer of the lock falls, and communicating to the end of the barrel. C is a copper ball, in which the air is to be compressed by a condensing syringe, (which see.) To use it, charge the barrel with a ball, fasten on the ball C, and pull the trigger, when a quantity of the air escaping from C, and expanding instantaneously in the barrel, drives forward the ball to a distance of 80 or 100 yards, and almost without noise.

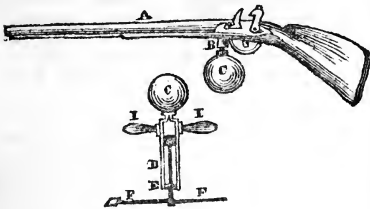

AIR PIPES. Pipes used to ventilate a ship's hold. A pipe extends from below to the ship's stove; here becoming heated the air within it is rarefied, and passes upwards, and thus it continually draws away the contaminated air round the lower end of it.

AIR PISTOL, or CANNON, Electrical. Consists of a tube of brass, in the end or side of which a glass or ivory tube is inserted, with a bent wire passing through the tube, so that when a spark is taken on the wire from an electrical machine, the fluid may pass in a spark from the point of the wire which is within the tube, if, therefore, it be filled with hydrogen, and corked up, a spark will inflame the hydrogen, and an explosion ensue.

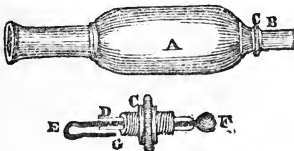

A shows the brass tube, or chamber. At the end a glass tube is situated, and now supposed to be covered with a cap B, which screws on at C. The cap being removed, the structure is seen in the figure below. C is the screw, one end of which screws to the brass chamber, the other holds the cap. D is the glass tube. E the bent wire. F the ball to receive the spark from the machine. At G the place of its passage from the point of the wire to the outside case, and when it

inflames the gas. The figure below is a simple form of the instrument. The electrical cannon is of the same nature; but of a different shape, as its name indicates.



AIR PUMP. An instrument to exhaust the air from, or condense it in, close vessels. It is the principal machine employed to illustrate the science of pneumatics. The following, which is the single-barrelled air pump, is the simplest form of the instrument. Fig. 1, shows its outward appearance—fig. 2, the same in section.

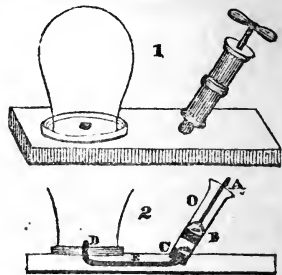

It consists of a syringe, connected with a tube, upon the other end of which is screwed a well-ground brass plate, upon which rests the receiver. Drawing up the handle A of the syringe, the valve at B, which opens upwards, is closed, and a vacuum being produced under it, the valve C is opened, and the air from the receiver D passes into the syringe; by pressing down the handle of the syringe, the lower valve is closed and the upper one opens; thus air equal to the size of the piston is got rid of. Thus by the alternate action, the air from the receiver is gradually exhausted.

The following cut shows the usual form of the double-barrelled air pump. The valves are as in the former instance, and the handle being worked to and fro moves a wheel, and with that the two racks up and down alternately.

Fastening the receiver down by a strap across it, and reversing the valves, will cause the air to be condensed. (See *Air Gun*.) The air pump is not merely a philosophical instrument, but has lately been employed in many mechanical processes. One is attached to the low pressure steam engine to draw off the air extricated from the boiling water. Mr. Howard, by drawing the air from the sugar pans, allowed the liquid sugar to boil at a much less heat than is usually applied to it; and upon the same prin-

ciple very superior medicinal extracts are now made; it has also been applied to distillation with success. Tanning is found to succeed more rapidly and surely in exhausted vessels. Filtering is also materially assisted; stereotype and other metal casting is, by exhausting the air from the moulds, conducted with much greater certainty, and as if to complete the catalogue of uses of the air pump, a pneumatic railway and other vacuum engines have been lately constructed. (See *Richie.*)

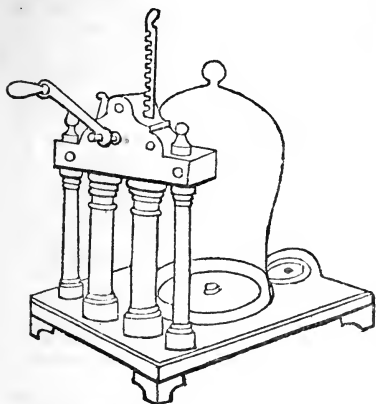

AIR PYROMETER. A somewhat clumsy and expensive instrument, proposed by M. Schmidt, of Jasy, in Moldavia. Its construction is as follows:—A is a bottle of platinum. B a tube of the same metal. A is immersed in the heated substance to be examined. B conveys the expanded air from A into an air-tight cistern C, which is filled with water. D is a thermometer to ascertain the temperature of the water before the experiment. E an open tube, dipping in the water. The heat of the substance around A is indicated by the great or less expansion of the water, and its ascent into E.

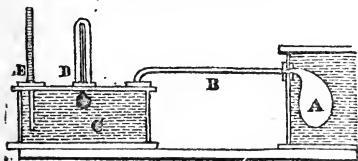

AIR STOVE. An inclosed fire-place, so constructed as to admit a stream of air to pass round it, or through it; and this impinging upon heated surfaces is rarefied, carried upwards, and warms the apartment. There are numberless modifications of this principle, but they all may be reduced to two. First, such as admit the air to play against metal, which is heated by a direct

fire. The second pass the stream of air through a cylinder of steam. The following cut represents one of the first kind, seen both in elevation and in detail.

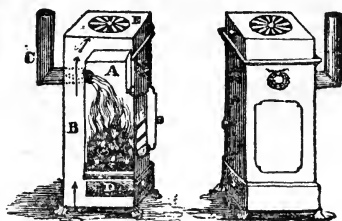

A is a square cast-iron box, closed at top, and open only at the bars at bottom, to let out the ashes, and let in the stream of air that keeps up the combustion. Opening also in front with a door to supply fuel, and having a pipe C as a chimney. B is a cast-iron case, entirely surrounding A. There is a drawer below to catch the ashes. The air enters at bottom between the two cases; it passes upwards, touching the outside of A, and thereby becoming heated, escapes through the top E, where is a register to regulate the draught of air required to heat the apartment, as there is also in the front of D to regulate that appertaining to the fire. If it be required to warm an apartment distant from that in which the stove is placed, a pipe is affixed to the top of the stove, instead of the register, and this pipe carried to the required situation.

AIR SHAFTS. In mines holes left for the foul air to escape, and fresh air to enter.

AIR THERMOMETER. A thermometer which indicates changes of temperature by air contained in a bulb and tube. The following, called the differential air thermometer, is its most useful form. A A are two bulbs, connected by a glass tube, and supported by a foot. The tube contains a small quantity of colored sulphuric acid; when one of the balls is heated, it drives the liquid towards the other, and the degree of this repulsion is indicated on a scale, and the different temperature of the two bulbs instantly seen.

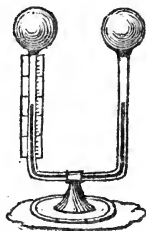

AIR THERMOMETER, Electrical. (See *Kinnersley*.)

AIR TIGHT. That degree of closeness in any vessel or tube, which prevents the passage of air at its usual pressure.

AIR TRAP. A contrivance for excluding the effluvia from drains, &c.—a water joint is best adapted for this purpose.

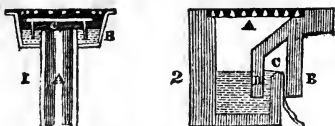

A is a pipe connected with the drain below, and soldered by the cup B (which has a metal cup attached to it,) with the sink hole above. Over the top of A is inverted a cup E, the edge of which extends to nearly the bottom of B. The holes down which the water runs are all outside of the sides of the cup. When water runs down, it fills the space between A and B, until it passes over the top of the inner pipe, and runs away, while the water joint prevents the return of any smell from beneath.

AIR VALVE. A valve belonging to steam boilers, the intention of which is to supply air to the boiler, if, by a sudden cooling of the water, letting off the steam, or other cause, the boiler should have a vacuum formed within it, in which case the atmospheric pressure from without, might, and occasionally does, press together the sides of the boiler. This contrivance is very simple, and resembles in appearance and mode of action the common lever safety valve, except

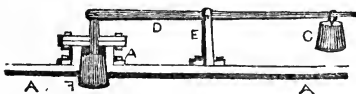

that it is the air which opens it by pressure from without, and not steam by pressure from within. AAA is part of the top of the boiler. F a plug valve, opening downwards. C a counterpoise weight, to keep it in its place under ordinary circumstances. The lever D is supported upon the fulcrum E, and the weight C is capable of being removed to any required distance from that fulcrum. The valve, therefore, may be made so as to adapt itself to any degree of pressure from without that may be deemed safe, not exceeding 15 lbs. per square inch, the amount of atmospheric weight.

AIR VESSEL. A vessel forming part of a forcing pump, fire engine, or other similar hydraulic machine, intended by the elasticity of the compressed air within it, to keep up stream of water while the action of the

pump is making the return stroke. (See *Force Pump*.)

AIRY. Paintings, or other works of art, which are light and lively.

AISLE, or AILE. The lateral divisions of a church.

AJUTAGE. The tube or mouth from which water is discharged to or from water wheels, and other hydraulic engines.

ALA. The wing of a building, side passage, &c.

ALABASTER is of two kinds—one a sulphate of lime, or gypsum. The other a carbonate of lime, analogous to marble, but softer in texture. The oriental alabaster, which is of this kind, is the most valuable, and of extremely varied and beautiful colors. It is used chiefly for the manufacture of bell handles, time-piece cases, &c. The Italian alabaster is also of various colors, but that which is pure white, and of silky marble-like appearance, is preferred. It is cut into innumerable ornaments, and small pieces of statuary, for the decoration of houses, &c.

A-LA-GREC. A particular kind of fret ornament, called often the Grecian border.



ALARM, or ALARUM. Any self-acting instrument adapted to give notice to a person of some occurrence happening, such as fire, thieves, time of night, &c.; thus the striking part of a clock is an alarm, so is the railroad whistle; but a bell, or other musical instrument, is not, because sounded by direct human agency. Alarums are endless in form and materials. The following is one invented by Mr. Russell, as a preservative against fire.

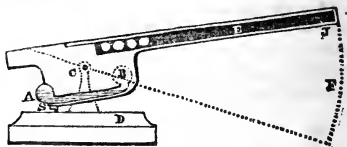

AB is a pulse glass, partly filled with a liquid, suspended upon its centre, and inclosed by wood, except the ball A. If a fire occurs, the air in the top of A expands, drives the liquid into the bulb B, this becoming heavier, overbalances the other bulb, and brings down the lever C, which is hollow, and has in it some bullets, these running down the tube, give the fall of the lever sufficient impetus to ring a bell or fire a pistol.

ALBUMEN. A peculiar chemical substance, found pure in the white of eggs, which are wholly composed of it; mixed with water it

is called *glaire*, and used as a varnish for the leather cover of books, kid shoes, &c., being merely put on with a small piece of sponge. Glaire and quick lime form a cement for joining china, glass, &c.

ALBUM GRÆCUM. The white dung of dogs, sometimes used to soften leather in dressing. It consists of digested animal matter, and phosphate of lime.

ALBURNOUS. Composed of albumen.

ALBURNUM. Sapwood, that is, the outer rim or growth of wood in a tree, which has not yet attained its strength, or solidity. It is often of a lighter color than the heart-wood, as is seen very conspicuously in the *lignum vitæ*, where the real wood is nearly black, and the albumen white.

ALCHEMY. The science of chemistry, as it was applied in former times to the attempted transmutation of the baser metals into gold; the discovery of an elixir vitæ, or universal medicine; a universal solvent; and other visionary substances. The first of these objects, was the principal one aimed at, and this by a powder, called the powder of projection, or philosopher's stone, which, mixed with any metal, and assisted by fire, was to change that metal into gold. The endeavour to discover this powder occupied the attention, exhausted the fortunes, and destroyed the health of hundreds of enthusiasts, during the middle ages, especially from the period of our King Edward I. to that of Charles II., and even after this period.

ALCOHOL. The purely spirituous part of liquors which have passed through the vinous fermentation, such as wine, beer, &c. These being distilled, an impure spirit passes from them, called low wines. This, again distilled, becomes purer and stronger, called then raw spirit, or whiskey. Deprived of its flavor, by a third distillation, it is rectified spirit. A fourth operation makes it spirit of wine. To separate from this the pure alcohol, it is saturated with hot pearl-ash, which seizes upon the remaining water, and leaves the spirit pure, or very nearly so. Also, a bladder being partly filled with spirits of wine, and put in a dry warm place, loses in quantity, but gains in strength, until the spirit parts with almost all its water by evaporation, and becomes nearly pure alcohol. (See *Distillation*.)

ALCOHOLATES. ALCHOATES. Compounds produced by dissolving by heat various saline bodies in pure alcohol, when cold crystals are deposited, which appear distinct, definite substances. Distilled tinctures are also often so called.

ALCOLIZED SULPHURIC ACID, or EAU DE RABEL. The same as sulphuric ether.

ALCOHOL of SULPHUR. The bi-sulphuret of carbon.

ALCOHOLIC, or SPIRIT BLOW-PIPE. A

blow-pipe which acts by the inflammation of a stream of the vapor of spirits of wine, as will be seen by the following cut:—

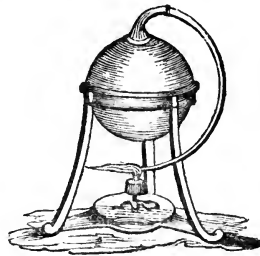

A is a vessel in which alcohol is kept boiling by the lamp beneath. The vapor issues from the point of the tube, and passing through the burning wick is inflamed, and forms a powerful jet of fire.

ALCOHOLIC THERMOMETERS. Such as are filled with alcohol.

ALCOHOMETER. (See *Hydrometer*.)

ALCORANES. High slender turrets adjoining to mosques. The same as minaret.

ALCOVE. A recess or place adapted for repose, usually separated from the rest of a room by pilasters, and a screen, or a curtain. Summer houses in gardens are often so called, particularly if imbedded in trees.

ALDEIDE. A name given by M. Liebig to pure alcohol, obtained by distilling alcohol over anhydrous sulphuric acid. He imagines it to be a new substance.

ALEMBIC. Synonymous with still.

ALEMBROTH, Salt of. A compound of bichloride of mercury and sal ammoniac, used by the alchemists to make a white precipitate, which Ure says consists of ammonia, muriatic acid, and mercury.

ALGAROTH, Powder of. A compound of oxyde and chloride of antimony.

ALGEBRA. The science of calculating by means of symbols and letters, instead of by figures. By this science we are enabled to calculate the most difficult mathematical problems, which arithmetic cannot reach; and also of expressing by a very few marks, what would otherwise require a lengthened explanation, and even that would be far less clear than an algebraic formula. This science is of very ancient date, having been known 1500 years ago, and probably long before.

ALGORITHM. An old word for algebra.

ALHAMBRA. The royal palace of the kings of Grenada.

ALIQUNT PART. A number that will not divide another number exactly, or without remainder; thus 7 is an aliquant part of 20 because 20 divided by 7 leaves the remainder 6.

ALIQOT PART. Such a part of a number as will divide exactly, without any remainder: thus 7 is an aliquot part of 21, because it is contained in it exactly 3 times.

ALIZARINE. A vegetable principle, extracted from the red coloring matter of the madder plant, by subliming the precipitate which water throws down from its alcoholic solution. It sublimes in extremely beautiful needle-shaped crystals, varying from a crimson red to a reddish yellow, or even a dirty white color.

ALKAHEST. The pretended universal solvent of the alchemists.

ALKALESCENT. Becoming spontaneously of alkaline properties, particularly vegetables of the cruciform or cabbage tribes; the evolution of ammonia occasions the peculiar scent when these are decomposing.

ALKALI. Chemical substances, acrid and caustic, which form soap with fat and oil, dissolve animal matter, combine with acids in definite proportions, forming neutral salts. They combine with water in any quantity, precipitate most metals from their acid solutions, and change most vegetable blue colors into green, and the yellow to brown. The chief alkalis are potass, soda, and ammonia. The two former are called fixed alkalis, the last the volatile alkali. Some of the earths are also alkaline, and also numerous vegetable principles. (See *Alkaloid* and *Earth*.)

ALKALI, Phlogisticated or Prussian. An old name by which the prussiates of the alkalis were once known.

ALKALIMETER. An instrument to ascertain the strength of an alkali. It consists of a graduated tube, into which a certain quantity of dilute sulphuric acid, of a known strength, is poured. The quantity of the alkali under examination found necessary to neutralize the acid will indicate its relative strength.

ALKALINE EARTHS. Such earths as unite and form neutral salts with the acids. They are lime, magnesia, alumina, lithia, baryta, and strontia.

ALKALOID. Any vegetable principle which has alkaline properties. The alkaloids are much used in medicine, but not in the arts. The chief are morphia, quinine, strychnine, brucine, veratrine, conine, atropine, delphine, emetine, and numerous others. The general method of procuring them is to make a solution of the vegetable, concentrate this a little by boiling, add ammonia till it is a little in excess—a precipitate will fall down; digest this in proof spirit to take away the coloring matter. Then the precipitate left is dissolved in boiling alcohol as strong as possible to be procured, and set aside to crystallize. The alkaloids are chiefly made in France, because of the expense of alcohol in this country.

ALKANET. The name of a plant, the root of which is used in staining wax, lip and other salves, perfumed oils, mahogany and marble. Its color is contained chiefly in the bark, is of a reddish brown, and is easily extracted by spirits of wine, and by oils, wax, and other unctuous substances. The roots are chiefly imported from France, where the best is produced.

ALLEGATION. An arithmetical formula for ascertaining the proper proportion of ingredients in a mechanical mixture, in proportion to its value.

ALLIACEOUS. Having the smell of garlic, as the arsenical minerals submitted to a certain degree of heat.

ALLODIAL. Independent of any superior.

ALLOY. A combination of two or more metals; also used to indicate any inferior metal, which may be mixed with gold and silver. If mercury be one of the combining metals, the mixture is an amalgam, not an alloy. The chief alloys are bras tombe, pinchbeck, prince's metal, bell metal, type metal, gun metal, solders, fusible alloys, &c. &c., which see under their respective names.

ALOEIC ACID. A name given by M. Liebeg to the bitter principle of aloes, procured by means of nitric acid—spec. grav. 1.25. It precipitates the salts of baryta, lead, and protoxide of iron, of a purple color, and forms a purple salt with potass. It is the same as carbazotic acid.

ALLUVION, or ALLUVIAN LANDS, or ALLUVIAL FORMATION. That which is washed to the shore by inundations, or deposited in valleys by mountain torrents, &c. Gravel, loam, clay, sand, brown coal, bog iron ore, wood, coal, &c., are of this kind.

ALMACANTAR'S STAFF. An ancient instrument for finding the amplitude of the sun, &c.

ALMERY. A niche or cupboard let into the substance of a wall, synonymous with locker. In Gothic buildings it was usually situated on the side of the altar, and used to preserve the vessels and instruments used in the communion service.

ALMOND. The kernel of the fruit of the amygdalus communis and amygdalus amara, or sweet and bitter almond tree. In medicine, triturated with water, almonds form an emulsion. The bland oil extracted from them by pressure is valuable in the arts, particularly for the use of the perfumer, while the chemist extracts by boiling and distillation the prussic or hydrocyanic acid.

ALTAR. An elevated place in which sacrifices are offered up to the Deity. Among rude nations it is a pile of hewn wood; in the earlier ages of Christianity was a wooden table. After the year 509 altars were chiefly of stone. Sometimes but one altar was in

the edifice or place; but in the Catholic churches, besides this, many more to different saints are erected. In England, the stone altars were ordered to be removed soon after the accession of Elizabeth.

ALTAR SCREEN. The partition behind the high or chief altar. They are often most magnificently sculptured and fretted.

ALTHEIN. The same as asparagin.

ALTIMETRY. The art of measuring heights.

ALTITUDE. Height. The altitude of the celestial bodies is reckoned in degrees, from the horizon upwards towards the zenith. It may be the apparent or the true altitude, according as we reckon it from the sensible horizon, or that which bounds our sight; or from the rational horizon, that which passes through the centre of the earth. Terrestrial altitudes may be calculated by trigonometry, the observation of shadows, and by the barometer. Celestial altitudes by the sextant, quadrant, &c. The altitude of a solid is the perpendicular height of its apex, above the base; of a tree, house, &c., its height above the ground; of a mountain, its height above the level of the sea. Altitude in perspective is the height of the eye above the horizontal ground line of the picture.

ALTITUDE, Quadrant of. A thin, flexible strip of brass, moveable at one end, around a joint in the lower part of a square head, which is furnished with a tangent screw. Its use is, that when fastened on to the brazen meridian of an artificial globe, it shall indicate the relative position of places, and other purposes, connected with that part of geography, commonly called the use of the globes. The strip of brass is graduated from zero to 90°, and the size of the instrument must be accordant to the size of the globe with which it is to be used.

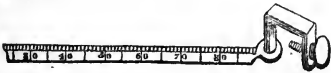

ALTO FAGOTTA, or OCTAVE FAGOTTA. A musical instrument, combining the strength of the horn with the sweetness of the clarinet. It is made of brass, like the former, and played with a reed, like the latter instrument. The compass is 3 octaves, commencing with C in the second space, bass clef.

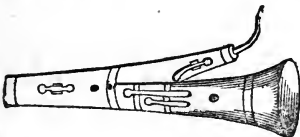

Note.—There are 3 holes and keys in the side opposite to that delineated, marked by 3 black dots.

ALTO RELIEF. Sculptured works, standing out from the general flat surface.

ALUDEL. A receiver for the products of sublimation. They may be of any shape, or formed of any material; generally, however, they are of earthenware. The word is now seldom used.

ALUM. A triple salt, consisting of alumina, potass, and sulphuric acid; chiefly an artificial product, made from the alum slate found in Yorkshire, and other places. One hundred and thirty tons of the slate produce about one ton of the salt. Alum is extensively used in dyeing, as a mordant; also, to imbue the paper in which gunpowder is wrapped to prevent accidental combustion, and resist better the moisture of the atmosphere. It is used also in tanning, fining liquors, bread making, and other processes.

ALUMINA. An earth which forms the chief constituent in clayey or argillaceous soil. It is white, tasteless, insoluble in water, soluble in acids, and caustic alkalies; has a powerful affinity for grease, and contracts equably by heat. (See *Pyrometer*.) The abundance of alumina in pipe clay, common clay, and fuller's earth, render these earths so valuable in the arts. The sapphire and ruby are pure alumina.

ALUMINATES. Many of the earthy combinations of alumina are thus called.

ALUMINUM. The metallic base of alum.

AMADOU. German tinder, is made from the spongy fungus, called *boletus igniarius*, by boiling it, beating afterwards with a mallet, and soaking in a solution of saltpetre. When now dried it forms an excellent tinder. The black amadou is the above rubbed over with meal-powder while wet.

AMALGAM. A combination of mercury with any other metal, usually made by the aid of heat. The following are the most useful amalgams:—

AMALGAM, Electrical. Melt $1\frac{1}{2}$ drams of zinc, and add 4 drams of mercury—afterwards pound up with a little tallow.

AMALGAM for Silvering Glass Globes. Melt 1 part of tin, 1 of lead, 1 of bismuth, and 2 of mercury. When nearly cold, pour into the globe, and turn it about.

AMALGAM for a Metallic Varnish. Melt 1 part of tin, 1 of bismuth, and 1 of mercury. When cold, mix with the white of an egg.

AMALGAM of Gold. Heat until it fumes, 2 ounces of mercury, then add one ounce of gold, (or silver.) Used for water gilding.

AMALGAMATION. The art of combining mercury with other metal; a process extensively employed in the purification of gold and silver.

AMANTINE. The poisonous principle of some fungi.

AMBER. A hard, brittle, semi-transparent substance; found plentifully in some parts of Poland, Italy, and on the shores of the

Baltic. It is combustible, and becomes electrical by friction. Is used chiefly by the varnish maker.

AMBERGREASE. AMBERGRIS. A solid, opaque, fatty substance, found on the sea shores, and supposed to be produced by the sperm whale. It is used in perfumery.

AMBITUS. An inclosure, applied to the space inclosed by the railings around a tomb, or to a burying place generally.

AMBO. Any raised platform, particularly applied to the raised part of a church which surrounds the altar. The reading desk was formerly called ambo.

AMBREIC ACID is procured by digesting ambreine in nitric acid.

AMBREINE. The base of ambergris.

AMBULATORY. A place to walk in, such as the cloisters of a monastery. An avenue of trees.

AMETHYST. A gem of a violet, yellow, or deep purple color, (the latter is the most valuable,) of great brilliancy and hardness; brought, the commoner sorts, from Germany; the best from Asia.

AMIANTHUS. A fine kind of asbestos, (which see.)

AMIANTHUS CLOTH, or INCOMBUSTIBLE CLOTH, is made as follows:—Expose amianthus to steam, separate the fibres with the hand, spin and weave it along with one-third the quantity of flax, or cotton; and afterwards throw it into the fire to burn the cotton away. The cloth will be found well formed, and uninjured by the fire. It has been used as an enveloping dress for those who have to enter burning houses, or to inclose substances which are to be burnt, and yet the ashes of them to be retained.

AMICABLE NUMBERS. Pairs of numbers of which each of them is equal to the sum of all the aliquot parts of the other; thus, 220 and 284 are amicable. Of 220, the aliquots are 1, 2, 4, 5, 10, 11, 20, 22, 44, 55, 110=284. Of 284, the aliquots are, 1, 2, 4, 71, 142=220. The other pairs of amicable numbers are 6232 and 6368—17296 and 18416—9363584 and 9437056.

AMICIAN MICROSCOPE, or ENGISCOPÉ. This instrument is constructed upon the reflecting principle, varying but little from that of the reflecting telescope of Sir I. Newton. The eye glasses, made of illuminating objects, stage, stand, &c., differ in no respect from those in common use. It is the reflection of the rays of light from the object that constitutes the perfection of the instrument. The construction will be understood by the following diagram, observing that the body of the instrument is horizontal, and object glasses vertical.

A is the object, supposed to be lighted by a candle and reflector or by any other method. The rays of light from it pass upwards,

through the object glass or glasses, to the plane mirror B. Thence they are reflected to the concave mirror C, and from this along the tube to a focus D, and afterwards pass onwards to the eye glasses. It is decidedly a microscope of excellent construction, especially as improved by Mr. Tulley and Dr. Goring. (See *Tulley and Goring.*)

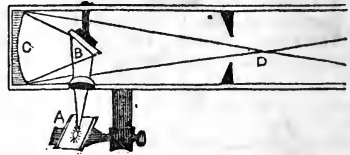

AMICI'S CAMERA LUCIDA. This instrument is, in general form, like that of Dr. Wollaston's. (See *Camera Lucida.*) The structure of the glasses is as follows:—

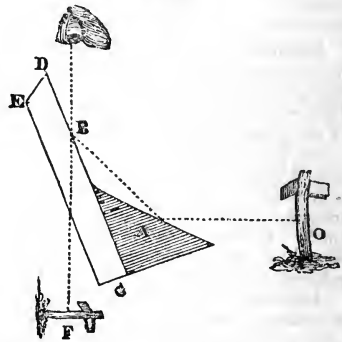

Suppose A to be a triangular prism of glass, or else a metallic speculum, having its upper side reflective, and connected by one of its other sides to a piece of plate glass D E C. The angle which the reflecting surface makes with the side of the plate glass being 130° . The rays from the object O impinge upon A, are reflected to B, and again to the eye, which looking downwards sees the object at F, through the piece of plate glass D E C. The pencil is also seen through the plate glass, at or near the same point; and as both are seen through the same medium, much less fatigue to the eye, and facility of management is acquired, than by Dr. Wollaston's instrument, where the sight is to be carried through media of such different density as glass and the air.

Another construction, which is also due to Amici, is as follows:—

Let A represent the mirror upon which the light from the object O is reflected. (It is to be observed, that in this instrument, as well as some of the others, the light traverses through the piece of plate glass, yet as the

sides of it are exactly parallel, it is not diverted from its course;) and D E C the glass as before. The light passes to the inner side of A, thence to B, and from B to the eye above, which beholds the object at F, seen through the glass as before.

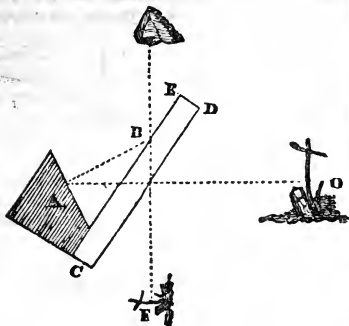

AMIDINE. A substance procured by boiling starch in a large quantity of water. Pass the liquid through a double filter, the soluble part will pass through; the membranes of the grains of fecula or starch will remain on the filter. Boil these again, and filter a second time; what is now left on the filter is amidine. It is whitish, very friable, in irregular fragments, destitute of taste or smell. It does not form a jelly with boiling water, is colored blue by iodine, and its solution is not viscid when mixed with potass.

AMMONIA. This volatile alkali, when pure, is gaseous, transparent and colorless, of a pungent smell, and caustic taste; is rapidly absorbed by water, then called liquid ammonia, or spirits of hartshorn. Ammonia is extensively used in chemistry, medicine, and the arts. It consists of 3 parts hydrogen, and 1 azote.

AMMONIAC. A gum resin, extracted from the dorema armeniacum, a Persian plant. Besides its use in medicine, it is employed in cements, mending china, glass, &c.

AMMONIACAL LIQUOR. A liquid which passes off from the retort when coals are submitted to distillation, as in the process of the gas manufacture. One ton of coals will produce from 17 to 20 gallons. It consists chiefly of the carbonate and the sulphate of ammonia, of uncertain degrees of purity.

AMMONIURETS. Substances composed of ammonia united with a metallic base.

AMMONIUM. The supposed base of ammonia, never yet obtained.

AMNIOTIC ACID. A crystallized acid, formed by evaporating the liquor amnios of the cow. It is soluble in both hot and cold water, is decomposed by heat, unites with the alkalies, and is precipitated from them by the other acids.

AMONTON'S FIRE WHEEL. A complicated machine, which was to rotate by the power of rarefied air. A description is in "Stuart on the Steam Engine." The machine is extremely complicated; and, if useful at all, was only so in the infancy of knowledge of steam, at which time, (1699,) it was suggested.

AMONTON'S THERMOMETER, consisted of a tube, 4 feet long, ending in a ball below, bent upwards as in the figure, and open at the other extremity. The measure of the temperature was the elasticity of a given portion of air included in the ball, and subjected to the pressure of an extra atmosphere, by pouring into the tube mercury—it formed a column of 28 inches in height; thus, using a tube only half as long as would have otherwise have been requisite. The instrument seems never to have been used, except by the inventor, because the varying state of the atmosphere rendered it uncertain in exact result.

AMORPHOUS. Not possessing any specific form.

AMPERE'S ELECTRODYNAMIC CYLINDER. An apparatus contrived of copper wire, wound spirally into a cylinder. The ends of the wire being connected with the poles of a galvanic battery, and the machine so suspended as to be free to move on its centre, the cylinder will arrange itself in the magnetic meridian.

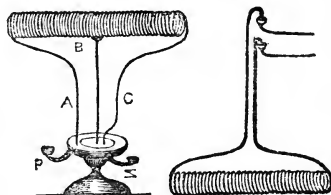

Two forms are given to this little apparatus, as above represented. In one the cylinder of wire is poised upon a point, the two ends of it dipping into two channels, cut in a wooden cup, and containing mercury. The small cups leading to the different sides of the battery being connected one with each channel of mercury. Thus, in fig. 1, the galvanic fluid enters at P, passes along the arm A, the coil B, the other arm C, and finally out at Z. The other figure shows the coil suspended from its ends in two cups filled with mercury, and leading to the different sides of a galvanic battery.

AMPERE'S ROTATIVE BATTERY, OR BUCKET. An instrument which, owing to its galvanic disturbance, rotates upon one of

the poles of a magnet, forming one of the most beautiful experiments in electro-magnetism.

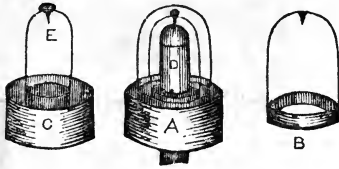

It consists of a double cylinder, made of copper, as represented in C. These are soldered together by a bottom cut in the form of a ring—the outer part fitting the larger cylinder, and the inner part the smaller ditto. When made, the cylinders may be half an inch apart, and the outer one 2 or 3 inches in diameter. The centre part of the bottom is cut away, so as to admit a magnet, D, up the inner cylinder, until it bears upon its pole the point E—this point being connected with the inner cylinder by a wire. The second part of the apparatus is at B; it consists of a hoop of zinc, a wire to hold it, and with a point at top. When in use, the cylindrical cup C is to be put on the pole of a magnet; the hoop and wire B is to rest upon it, and dilute acid to be poured in, when the copper will turn round one way, and the zinc hoop the contrary way. A good connection between the two being kept up by a drop of mercury being poured into the cup at the top of E.

AMPHIPROSTYLE. A building having a portico at each end.



AMPHITHEATRE. A spacious building, either oval or round, having the arena or pit encompassed with a vast number of seats, disposed in rows, and rising gradually one over another. Its use among the ancients was to exhibit shows to the people, as the combats of gladiators and wild beasts. The amphitheatre of Vespasian or Titus, called the Coliseum, was one of, if not the very largest. It held from 80 to 100,000 spectators, and at its opening a combat took place of nearly 9,000 wild beasts. It is built of stone, has four rows of columns externally. The walls are 160 feet high, the interior is 620 feet long, and 513 feet wide.

AMPHISCII. All people living on the torrid zone have their shadows directed in one time of the year towards the south, and in

the other towards the north; in consequence of the difference in the sun's declination.

AMPHORA. A vase having two handles, and containing from 7 to 10 gallons.

AMPLITUDE. The position of any of the heavenly bodies when on the horizon. Thus we speak of the sun's rising amplitude, and his setting amplitude, meaning thereby the exact point of the compass he is visible in at the time of rising or setting, or when just visible above the horizon. It is reckoned in degrees from the east and west points, and is the complement of the azimuth.

AMPLITUDE, in Gunnery. The range of a projectile.

AMPULLA. An oblong vessel, bellying out like a jug, chiefly of earth or glass; used among the ancients to contain oil for the anointing their bodies.

AMYLIC ACID. Procured by distilling starch, mixed with equal parts of black oxide of manganese, and moistened with water. It turns sour, reddens vegetable blues, and with bases forms neutral salts, very soluble, and deliquescent.

ANACAMPTICS. The science of the reflection of sound, particularly echoes. It is now called catoptics.

ANACLASTICS. An old name for dioptics.

ANACLASTIC CURVES. Apparent curves seen at the bottom of a vessel of water, caused by the refraction of light.

ANACLASTIC GLASSES. A kind of sonorous, funnel-shaped phials, made with extremely large, slightly concave bottoms, as thin as possible. On applying the mouth to the orifice, and gently sucking out the air, the bottom gives way with a tremendous noise, and the convex becomes concave. Upon breathing gently into the glass, the bottom, with no less noise, bends back to its former place, and becomes again convex.

ANAGLYPHIC ART. The art of chasing, carving, and embossing plate; in opposition to diaglyphic, which see.

ANALEMMA. A tabular mark, usually in the shape of the figure 8, depicted across the torrid zone, on a terrestrial artificial globe, to notify the sun's declination on any day in the year.

ANALYSIS. The art of separating a compound into its constituent parts. In chemistry this art is of the greatest importance. The opposite of analysis is synthesis.

ANALYSIS, in Mathematics, is of two kinds; finite analysis, or algebra; and the analysis of infinites, called also the *new analysis*, fluxions, or differential calculus.

ANALYSIS OF POWERS. The resolving them into their roots.

ANALYSIS OF CURVED LINES, shows their constitution, nature, and properties.

ANALYTICS. The science of mathematical analysis.

ANALYTICAL FORMULA, or EXPRESSION. A combination of symbols, or signs, expressing or representing a series of calculation, and including every particular case that can arise from a general law.

ANALYZING PLATE. A plate of glass, or a slice of a crystal; used for examining the properties of polarized light.

ANAMORPHOSIS. A distorted representation of any object, so contrived as to appear symmetrical from a certain point of view; or when reflected from a certain-shaped mirror, such as one which is cylindrical, conical, &c. Thus the following will appear in true form when viewed from the point C, and at the height D, as is easily managed by cutting a piece of paper, as is represented in E.

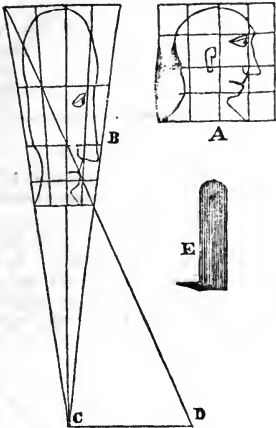

ANATRON. The scum which floats upon molten glass in the furnace, sometimes called sal vitrei, which, when taken off, melts in the air, and becomes common salt. Also, a compound salt, formed of quicklime, alum, vitriol, common salt, and nitre; used as a flux for certain metals—this is also called terra saracenic.

ANBURY. Club root, as found on the cabbage, occasioned by the puncture of an insect.

ANCHOR. A heavy curved hold-fast, to retain ships in a required position. They are either mooring anchors, such as are sunk in docks, or anchorages, for the general use of tying up the vessels around; or ship's anchors, for the use of one ship only, and that when and wherever it may be requisite.

ANCHOR and COLLAR. *Collar and Clamp.* Strong hinges used for flood, lock, and other strong gates. They are of the following form; the anchor being let into the stone-

work, and the clamp rivetted, or rather wedged to the anchor.

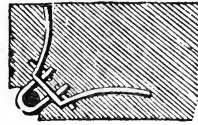

ANCHOR. In architecture, part of the echinus, or egg and anchor ornament. (See *Egg*.)

ANCONES. The ornaments depending from the cornice of Ionic doorways and windows. (See *Consoles* and *Trusses*.)

ANDIRONS. HANDIRONS. The logs or iron bars used formerly to support the burning logs in the hearth, now mostly superseded by stoves.

ANDROIDES. A term sometimes given to those automata which imitate human kind.

ANDRON. A passage between two houses.

ANELECTRODE. The positive pole of a galvanic battery.

ANEMOMETER. An instrument for measuring the strength, or velocity of the wind. The following is one of the most simple:—

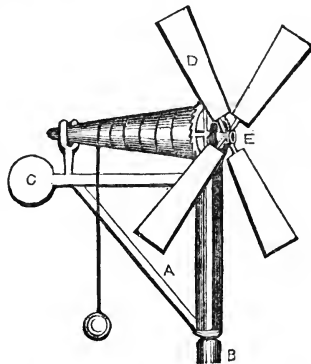

The frame A turns round upon the spindle B, by the action of the wind upon C. D is a vane fixed on the axis E, which is, in its middle, conical, upon one end of which is fastened a string. The wind acting upon the sails winds up the string, while a ratchet wheel and catch prevents any retrograde motion.

ANEMOSCOPE. Any instrument to ascertain the direction of the wind; a weather vane; chiefly applied to those contrivances, which, connected with a weather cock above, bring down its indications to a dial placed at a distance.

The following shows one of the most usual arrangements. The spindle which supports the letters is hollow. The vane A is fixed to a long iron rod, passing downwards to the

wheel B. C is a similarly-sized and shaped wheel working in it, and connected by its spindle with the index or hand D belonging to the dial plate. The wind turns the vane, that turns the wheel B, which works C, and that turns D, exactly as much as the vane at top is affected by the wind. In the same cut is seen the front view of the dial plate.

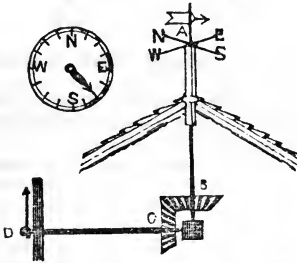

ANFRACIOUS. Turning or winding in and out irregularly, as a metallic vein.

ANGLE. A corner formed by two or more lines, or surfaces, from different directions, meeting each other. If the angle be formed of lines only, it is called a *linear* angle, such as that made by the junction of two hedges in a field; if consisting of the union of two surfaces it is a *superficial* angle, as the corner of a house, wall, &c. When more than two surfaces meet in a point a *solid* angle is formed; this is the case with crystals, spires of churches, &c. A solid angle may also be made by a circular body, as the angle at the apex of a cone. In a pyramid all these different angles are seen; each face being a triangle, it contains three linear angles—the union of one face with another forms a superficial angle, while at the apex, and also at the corners of the base, are solid angles.



Angles, whether linear, superficial, or solid, are further distinguished from each other by the form of the lines which bound them. If these be straight they form a *rectilinear* angle, such as A; if of curved lines, a *curvilinear* angle; if of circular curves, a *spherical* angle, as B; if one line be curved, the other straight, a *mixed* angle is formed, as C.



Angles are measured in degrees. The circumference of every circle is divided into 360° . Cut the circle in half by a diameter DB, each half will be 180° . Now as the diameter is but one straight line, no angle will be formed at the centre; thus no angle can be so much as 180° , but it may be any thing less than this. Erect a perpendicular CO at the centre of the last line, and two equal angles will be seen at the centre, each measuring 90° it will be a right angle. If the second line CO be not perpendicular to AB, the angle on one side would be an acute angle, or less than a right angle; the angle on the other side obtuse, or greater than a right angle, as is seen by the angles on each side of AO. Oblique angle is a name common to all that are not right angles.

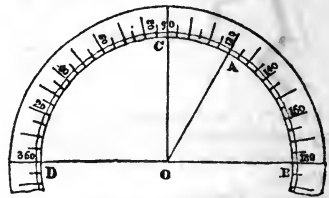

An angle, when standing alone, is indicated by a single letter, when united with other angles, three letters are necessary to distinguish it. Thus in fig. 1, (below,) A alone marks the angle sufficiently. In fig. 2, the corresponding angle would be called BAC, to distinguish it from the angle DAC, EAD, EAC, or DAB. The letter A being common to all.

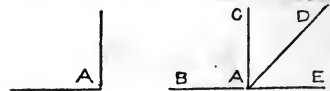

ANGLE, Adjacent or Contiguous, Exterior and Interior, are such as have one side common to both, they being on opposite sides of it.

ANGLE, Vertical or Opposite. When an angle is formed by continuing the legs of another beyond the angular point, three other angles are formed. Those which are of the same size are called vertical, or opposite, as BAC is vertical to EAD, and EAC to BAD; also BAC is an exterior angle, or without the original figure, and EAD an interior angle.

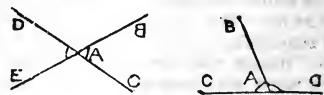

ANGLE, Alternate. When a line is drawn across two parallel lines, the two angles on

the same sides of it are alternate, as $A B C$ and $D C B$ are alternate.

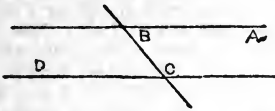

ANGLE, Salient, Sortant, or External, and Re-entering or Internal. One angle projecting beyond another, or beyond a surface. The outer part is called a salient angle, the inner a re-entering. Thus in the following figure the dots are salient angles, the crosses are re-entering angles.

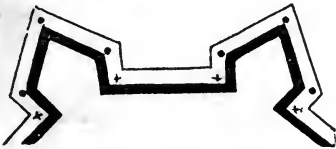

ANGLE of a Segment, or a Semi-circle. Any angle formed by two lines drawn from the opposite ends of a segment, and meeting in the arc.

ANGLE, Truncated, Chamfered, Splayed, or Beveled. It often happens that the extreme point of a solid or superficial angle is cut off, either naturally or by design. If the latter, as, for example, in the corner of a wall to prevent an abrupt turn, it is said to be splayed or chamfered; if naturally occurring, as is extremely common in crystals, it is called a truncated angle; or, as it is better expressed, truncated at the angles, as in the following cut:—



Although in this case the angles are removed, yet what the figure would have been with them is as easily ascertained by the inclination of the sides, as if the angles had remained perfect.

ANGLE, Visual. The apparent size of an object depends upon the size of the angle, which its opposite extremities make with the eye of the observer. The greater the angle, of course the larger the object will appear to be. This is totally distinct from its real magnitude, which at all distances is the same, though the object is apparently so much larger when near than when remote.

ANGLE of Aperture. An angular measurement of the rays of light, admitted into

the aperture of a telescope or microscope. (See *Aperture*.)

ANGLE of Contingence, or Contact. Also called tangential angle. The angle made by the contact of a tangent, and the curve upon which it impinges.

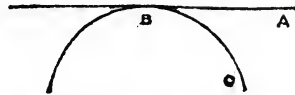

ANGLE of Draught. When a power is applied to drag or roll a body over a surface, it has to overcome certain obstacles, particularly those arising from the inequality of the ground, which are greater or less according to their own nature, and the friction or weight of the moving body. There is in every case a certain direction of the drawing power better adapted than any other to overcome these obstacles; this is called the angle of draught. So, also, when the motive power be animal strength, it is always to be considered at what angle with the ground the muscular powers of the animal are best called into action.

ANGLES of Elevation, is that angle with the natural level of the ground, at which a cannon or other similar instrument is pointed, in order that the ball, or other projectile, may reach a certain point, after being fired from it. This angle, as illustrated by the following example, will, of course, vary according to the strength and quantity of gunpowder, state of the wind, weight of ball, &c. In all cases, an angle of 45° with the horizon is that elevation at which the projectile is thrown the farthest.

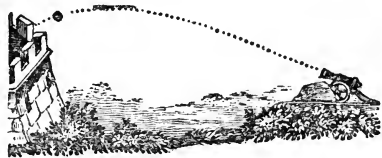

It also signifies the angle at which an elevated object is seen by an observer on the level ground, as, for example, a balloon, and this without reference to its actual height; for it will be seen from the following diagram that the angle of elevation has reference to the distance from the observer, as well as its positive height.

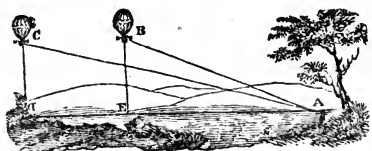

The angle of elevation of the balloon when at B is B A E, but when the balloon is at C its angle of elevation is C A D, although the height of it from the ground is the same in both instances, B E and C D being equal. When below the plane of the observer it is called the angle of depression.

ANGLE, *Horary*. The angle formed with the meridian of any place, by a great circle which passes through a star and the pole.

ANGLE of Incidence and Reflection. The angle of incidence is the angle at which a moving body strikes a flat body at rest; and the angle of reflection is that at which the same moving body flies off again; and, supposing no disturbance from roughness of surface, or irregular friction, one of these angles will be always equal to the other, or as it is common to say, "the angle of incidence is equal to the angle of reflection." This great law of physics is of the first necessity to be considered in treating of light, heat, and sound. It is also the fundamental principle upon which billiards and similar games are played. These angles may be exemplified as follows:—

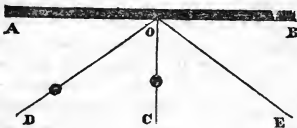

Let A B be a flat and smooth surface. If a ball be bowled against it from C, so as to strike it perpendicularly at O, it will fly back again to the hand, because, as it is bowled to the flat surface at the angle of 90° , it flies back again at 90° ; that is, comes back in the same direction. If the ball be thrown from the point D to the point O, it will fly off towards E, making the angle of reflection B O E equal to the angle of incidence A O D.

ANGLE of Inclination. The angle which one line or plane makes with another, the exact direction of which is understood, or known to be either perpendicular or horizontal. Thus we say, the side of a hill makes a certain inclination with the natural level. The roof of a house makes an inclination of so many degrees with the flat of the building. An arch may have a certain inclination with its abutments. This general application has occasioned the word *inclination* to be used as synonymous with angle generally.

ANGLE of Polarization. One source of the polarization of light is reflection from polished surfaces, when it strikes those surfaces at particular angles only. This is called the angle of polarization of the substance which reflects it. Thus glass polarizes light at an angle of 56° ; air at 45° ; water at

$53^\circ 14'$; rock crystal at $57^\circ 22'$. (See *Polarization*.)

ANGLE of Position. Usually the curvilinear angle, formed by two great circles drawn through a star to the poles of the ecliptic and equator. Or it may be used to signify any angle made by lines drawn from any point under consideration to any two points, the relative position of which is required. Thus, suppose a person is situated on a bank, and desires to know the position of a windmill and a church, the lines which connect these two points to him forms the angle of position between them.



ANGLE of Refraction. When light passes in an oblique direction from one medium to another of a different density, it becomes bent out of its former direction, in proportion to the respective density of the two media. Thus, dip a straight stick in clean water, perpendicularly, and it will still appear straight, there being no refraction. Then incline it towards either side, and instead of its continuing as before, it will appear bent at the place it touches the water.

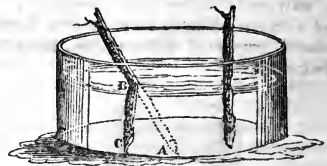

The quantity and degree of this bending A B C is the angle of refraction.

ANGLE of Repose. Angle of Friction. The greatest slope at which a carriage will stand at rest on an inclined plane. On a rail-road it is about 1 foot in height, in 150 in length; and on a hard turnpike road 1 in 40 feet. Also the angle at which newly-carted earth will rest without slipping down. In perfectly dry sand this is about 30° ; in clay and other tenacious soils about 45° .

ANGLE BAR. The upright bar of wood which stands at the extremity of each angle



of a polygonal window, or canopy, and reaching from the bottom to the top of the window. Also the angular timbers of a spire, or any thing built of a pyramidal or prismatic form.

ANGLE BRACES, or ANGLE TIES. Pieces of wood fastened across the angles of square and other angular frames, in order to strengthen the joints at those parts, and to keep the frames of a proper shape.

ANGLE IRONS. Knee Irons. Elbow Irons. Bars of iron forged of an angular shape, to strengthen the various joints of iron work, particularly those of steam boilers.

ANGLE RAFTER. The rafter at the junction of any two sides of a hipped roof, and upon which the short rafters are fastened at the upper end.

ANGLE RIB. A curved piece of timber placed at the angles of groined ceilings.

ANGLE STAFFS, or STAFF BEADS. Beads of wood placed vertically at external angles of windows, doors, &c., where two surfaces of plaster meet, in order to render this part stronger, and avoid the liability of the plaster in such situations being broken, or damaged.

ANGLO-GREEK, ANGLO-ITALIAN, ANGLO-NORMAN, ANGLO-ROMAN, &c. Different styles of architecture, so called because founded upon the principles of art adopted by these foreign nations, and yet of edifices built in this country, and so modified as to be adapted to our climate and manners. Of the Anglo-Roman and Anglo-Saxon very few remains exist. Of the former, the Pharos of Dover Castle; St. Martin's Church, Canterbury; Richboro' Castle; and Newport Gateway at Lincoln, with a few walls and tessellated pavements, are the only relics. Of the Anglo-Saxon buildings still fewer records exist. The Tower of Earl's Barton, Northamptonshire, and Barton, Lincolnshire, are supposed to be of this æra. Anglo-Norman remains are frequent; example, Rochester Cathedral, St. Bartholomew's Church, and the Temple Church, London, St. Alban's Abbey Church, &c., were built in this æra, which extended from William I. to Henry I; gradually passing into the pointed Gothic in succeeding reigns. The Italian or Venetian, blended with the Gothic, formed the Elizabethan structure; while the beautiful proportions of the Greek styles were introduced into England by Inigo Jones, in the reign of Charles I., of which the first and one of the finest examples is the Banqueting Room of Whitehall. Anglo-Grecian buildings are now of constant erection.

ANGULAR CAPITAL. The term is applied chiefly to the Ionic capital, when all its sides, or where two of its adjacent sides are made to correspond, in order that it may be adapted to the corner of an edifice which has co-

lumns in front and flank, that it may range with both.

ANGULAR MODILLIONS. Modillions which are placed at the corner of a building, and so as to project from the exact angle formed by the two sides, equally deviating from both. (See *Modillion*.) Angular capitals and modillions are not found in the classical remains of Greece, nor yet in the more ancient Roman edifices.

ANGULAR MOTION. When a body moves in an arc of a circle, its motion is not measured by the direct distance passed over, but the number of degrees; so that two bodies may have the same angular motion, whose real velocities are very different, as is seen in the following diagram:—

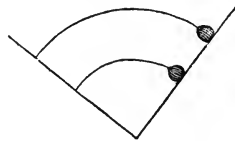

The angle is 90° , thus the two balls in going across the angle would each have 90° of angular motion, though, as will be evident from their respective paths, one will travel nearly twice the distance of the other.

ANGULAR MOTION, or VELOCITY OF THE EARTH, is its diurnal rotation, measured in degrees; thus, as its rotation is once in 24 hours, its angular motion is 360° in this time; but as no angle can be more than 180° , the angular motion is not mentioned as more than this. The term is applied when calculating the tides, and the angular position and velocity of both moon and earth must be observed.

ANGULAR VELOCITY. The swiftness with which a body revolves around a given point, as a sling around the hand, or the earth around its axis.

ANGULOMETER. An instrument adapted to measure external angles. The following, by Mr. Hall, will show its principle and usual construction:—

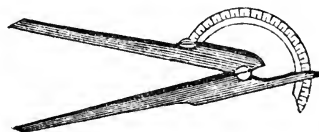

ANHYDROUS. Such substances as are without water in their composition.

ANIMAL CHARCOAL. Charcoal produced by burning the bones and other parts of animals.

ANIMAL ELECTRICITY. A certain development of the electrical fluid in the muscles of particular animals, whereby they

are enabled to give shocks, either for their own defence, or for catching their prey. All the electrical animals known are of the fish kind, either different species of the ray kind, or of eels. The most powerful is the *gymnotus electricus*, an eel 4 or 6 feet long, found abundantly in the marshy rivers of Guiana.

ANIMAL MAGNETISM. A name given by Mesmer, in the latter part of the last century, to certain effects produced by one person upon another, and which were assumed to be of a magnetic nature. The means employed are touching with the hands, waving them in certain directions, along or in front of the face, while the magnetizer remains opposite the person magnetized, and fixes his eyes steadfastly upon him. After some time, the person operated upon, (who, it may be remarked, *ought* to be of weak nerves and constitution, and of the opposite sex,) becomes languid, and falls asleep, from which he cannot be awakened until the magnetizer dissolves the enchantment by some counter-spell. The whole is most probably the effect of imagination.

ANIMAL POWER. The capability of an animal to sustain weights, and to move with more or less rapidity. An animal can support the greatest load when standing still. The load he can bear when moving diminishes as his velocity increases, till at length his whole strength is expended in moving along his own weight. The greatest effective power of an animal, as, for instance, a horse, is when he moves with one-third his greatest velocity, when unloaded, and bears 4-9ths of the load he can just move. Animal strength depends somewhat therefore upon the weight of the animal itself, but still more so upon the manner of using its strength. A horse's power is best directed when he draws a loaded carriage, and also when, by the adjustment of the load, a part is thrown upon his back. A man's power is most called out in rowing. If in working a pump he can exert a force of 100 lbs.; in turning a winch the same exertion will be equivalent to 167 lbs.; in ringing a bell 227 lbs.; and in rowing a boat 248 lbs. A horse's strength is, according to Smeaton, equal to that of five men.

ANIME. A resin of a pleasant scent, used in perfumery and medicine.

ANIMIN. An oily fluid, odorous like hartshorn, extracted from animal oils by distillation.

ANION. That part of a body decomposable by galvanism, which is attracted to the anode or positive pole; thus, in the decomposition of water, as oxygen is attracted to the positive pole, it is an anion, while the part, (hydrogen,) which is taken to the negative pole is a cation, and both together are called ions.

ANKER. A cask holding 10 gallons; applied only to the casks of brandy brought by smugglers, called by them *tubs*. A 5-gallon cask is called a *half-anker*, a *pin*, or a *keg*.

ANNATTA. (See *Arnotta*.)

ANNEALING. A process by which glass and also various metallic bodies, are changed from a state of brittleness to one of toughness. This is accomplished by keeping them for a length of time at a very low heat, and afterwards cooling them very slowly.

ANNUAL EQUATION. (See *Equation*.)

ANNULAR VAULT. A vaulted roof, supported on circular walls, as was the west end of the Temple Church, London, and the Temple of Bacchus at Rome.

ANNULATED COLUMNS, are those that are clustered together, or joined by bands, as in Salisbury Cathedral, Westminster Abbey, &c.

ANNULET. The filets which surround the base of a Grecian Doric capital; usually 3 in number, each of the 2 lower of less diameter than that fillet above it. The rings, or bands that sometimes surround the shafts of other columns are also often called annulets.



ANODE. The positive pole of a galvanic battery, as opposed to cathode the negative. The anode is called also zincode.

ANOMALISTIC YEAR. The time that the earth takes to pass through her orbit, until she arrives at the exact spot again, which, on account of a slight movement in the line of the apsides, is rather more than a common year.

ANOMALOUS. Nameless, that is, so irregular in shape, color, &c. that it cannot be properly designated

ANOMALY. In astronomy signifies the deviation of the planets from their true perihelion, which arises from their inequality of motion. It is either *mean* or *true*. The mean anomaly is the angular distance from the perihelion, supposing it to move in a circle. The true anomaly is its angular distance from the perihelion in its elliptical orbit.

ANSÆ, in Astronomy. The ring of Saturn is so called, when it appears like a handle on each side of the planet, as is the case whenever the planet is in such a position that we see the exact edge of the ring.

ANTÆ. Pilasters which terminate the side walls of a temple, when they are brought beyond the inclosed part of the building. (See *Antis*.)

ANTEFIXA. Terra cotta, or sculptured marble blocks placed above the eaves of a building to hide the ends of the rafters;

when these latter are raised like ridges above the tiles, they have the honey-suckle, or other device, engraved upon them.

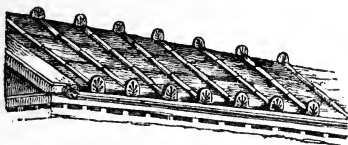

Such ornaments are often placed on the upper ends of the ridges also, as in the above example. The lion's head, or mask, placed along a cornice, and at the ends of a pediment, are likewise called antefixa; the following is such an one from the Greek.



ANTEMURALE. Any outwork.

ANTEPORTICO. An outer porch or vestibule, called the propylæum, in classic architecture.

ANTEPAGMENTS. The jambs of a door, when ornamented with mouldings similar to those of the architrave. The lintel, when thus ornamented, is called the *supercilium*.

ANTERIDES. Synonymous with buttresses.

ANTICUM. A porch; also that part of a temple between the body of it and the portico.

ANTHRACITE. A species of coal which burns without flame or smoke; it is very difficult to ignite, but once ignited, burns with an intense heat, therefore, of the utmost value in the smelting of iron. It is called also stone coal, blind coal, glance coal, and Kilkenny coal.

ANTI-ATTRITION. A mixture of 4 parts of hog's-lard and 1 of black lead; used to lubricate the axles of carriages, and the rubbing parts of other machinery.

ANTI-DRYROT. A name given to a solution of corrosive sublimate, when applied for the saturation of timber, as it prevents the growth of that fungus called the dry-rot.

ANTI-INFLAMMABLE SUBSTANCES. Such bodies as prevent others, to which they may be applied, from catching fire; such are alum, the carbonate of soda, potass, &c.

ANTICK. A fanciful composition of men, birds, beasts, foliage, &c., formed out of

each other, as is often seen on cameos and engraved gems; also all trophies and extraneous ornaments to buildings.

ANTIGUGGLER. A small tube, which is inserted into the mouth of bottles or carboys, to admit air while the fluid is running out; necessary because of the corrosive nature of the liquids contained, and the guggling and consequent splashing of which would be unpleasant.

ANTIMONY. A white brittle metal, of a striated texture, spe. gra. 6·712, melts at 810° Fahr., and volatilizes at a great heat; is soluble in most acids; unites with sulphur, chlorine, iodine, and phosphorus. It is used in medicine in different states, the making of printer's types, music plates, specula for telescopes, &c. Its medicinal properties were discovered by Basil Valentine, who administered it as an emetic to his brother monks; they, however, taking too much were killed; hence it is called anti-moine, or anti-monk. His future applications of it were more successful.

ANTIMONIC ACID, is a peroxide of antimony, in form of a white hydrate, procured by treating antimony with strong nitric acid, or nitro-hydrochloric acid, concentrating by heat, and pouring the solution into water. With alkalis it forms antimonates.

ANTI-PECULATOR. A name given by its inventor, Mr. Lawton, to a lock which cannot be picked.

ANTIPODES. That part of the world which is exactly contrary to another, both in latitude and longitude; or, in other words, if a hole be supposed to be bored from any given place through the centre of the earth to the opposite side, that part would be the antipodes to the former place. The antipodes to England is a point in the Southern Ocean, in latitude 51½° S, and longitude 180° W. At this place it is night during our day, and summer during our winter.

ANTIQUE. This term is used to signify a building, statue, gem, &c., made at a time when the arts were in their greatest purity and perfection among the Greeks and Romans.

ANTIQUE, Modern. Any thing made in modern times to imitate what is antique. Gothic architecture is sometimes so called.

ANTIQUE ORNAMENTS. Synonymous with arabesque, except that it contains the grotesque figures of animals, which true arabesque properly does not; it is more properly called grotesque. The initial letter B is of this kind.

ANTISCIL. The people living on different sides of the equator are antiscil to each other, because at noon their shadows are cast in contrary directions. For example, when the sun is on the equator, the shadows of those

who dwell in the northern hemisphere will be directed towards the north; and those in the southern hemisphere will have them projected towards the south.

ANTIS. A temple is in antis when it has *antæ*, or pilasters, connected with, and imbedded in the walls, usually with two columns between them.

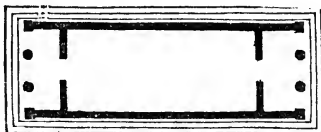

ANTISEPTICS. Substances which counteract the spontaneous decomposition of animal and vegetable matter. The principal antiseptics are common salt, sulphate of iron, nitre, sugar, vinegar, spices, corrosive sublimate, creosote, and charcoal.

ANTOECI. Those people who live under the same meridian, but on opposite sides of the equator, and equally distant from it, they have, therefore, day and night at corresponding times, but the seasons are contrary.

ANVIL. A solid mass of iron; made for the purpose of forging and hammering metal work upon.

APERTURE. Generally a hole, or opening. In optics, it signifies the hole next the object glass of a telescope, or microscope. According to the size of this aperture, so will be the conical pencil of light admitted to the instrument; and, in a great degree, its discerning power will be accordant.

APEX. The summit of any pointed body, as the apex of a pyramid, an obelisk, cone, &c.

APHELION. That point in the orbit of a planet, or comet, in which it is farthest from the sun; in opposition to perihelion, the nearest point. (See *Apsis*.)

APIARIES. A place where bees are kept; applied to a collection of, rather than a single bee-hive.

APLANATIC. Signifies free from error; applied to those optical instruments in which spherical aberration is completely corrected.

APOGEE. That point of the moon's orbit in which she is at the greatest distance from us. The term is, therefore, of the same meaning, when applied to the moon, as aphelion when applied to the earth, or other planets. The opposite to apogee is perigee. (See *Apsis*.)

APOGRAPH. A copy of any writing, in opposition to autograph, which is the original.

APOLLONICON. A name given by its inventors, Messrs. Flight and Robson, to a stupendous organ, long exhibited in London.

and capable of being played by mechanism alone, by the hands and feet alone, or by all these united. It has foot pedals, 1900 pipes, 45 draw stops, and 2 kettle drums; 3 barrels, each 2 feet in diameter, pricked with tunes, 3 wind-chests, 3 key frames, and 3 sets of keys, (250 keys in all.) Each barrel, wind-chest, set of keys, &c., belonging to a particular part of the instrument, and working either independent, or in unison with the others. The main cylinder is 8 ft. long, and has 5 octaves, with the following stops: open diapason, stop ditto, principal, twelfth, fifteenth, flute, sesqui altera, cornet, and trumpet. The second cylinder is 3 ft. 9 long for the bass notes from gamut G, 2 octaves downwards, these are called double diapason pedal pipes; the largest is 24 ft. long, and 23 inches square. The third cylinder is 8 ft. long, with the following stops: diapason, or corni stop, stop diapason, violoncello, German flute, wood fifteenth, trumpet, cremonas, flutes, vox humana, octave flute, hautboys, piccolais, trumpets, diapason, principal, &c. &c. The whole is inclosed in a case 20 ft. broad, 18 deep, and 24 high.

APOMETRY. The art of measuring things at a distance.

APOPHYGE. APOTHESIS. APOPHYSIS. A small curvature given to the top or bottom of the shaft of a column, to make it to fit the parts adjoining. It is also called the *scope* of a column.

APOSEPEDINE. A substance produced by the spontaneous fermentation and decay of various animal substances, particularly cheese. Called also caseous oxide. The scent and pungent flavor of old cheese are derived from it.

APOTHEOSIS. Deification, or placing among the gods; an honor conferred by the ancients upon many of their heroes, emperors, &c.

APOTOME. In mathematics, the difference between two powers, which can only be measured by power as 1 and $\sqrt{2}$.

APPARATUS. This general term includes the instruments, machines, vessels, and mechanical contrivances, used to illustrate the particular facts and laws of science, and with which to conduct its experiments. Also, in numerous of the arts, the same term is employed to designate articles, machines, and tools, used for certain specific purposes. Thus we speak of the whole of the implements used in chemistry, as chemical apparatus; or, if it be adapted for a particular object only, we designate it by an appropriate name; thus we say, a steam apparatus, a soda-water apparatus, an electrical machine, and so on. Occasionally articles are best distinguished by the names of their inventors, or by the place where discovered. For example. Woolf's bottle, Barlow's wheel,

Newton's telescope, Davy's miner's lamp, the Leyden jar, the Magdeburg hemispheres, &c. Inventors have frequently given a new name to their contrivances, by which they are desirous such contrivances should be distinguished, and if no other instrument for the like purpose be invented, such term remains an individual name; or, if others arise it becomes the name of a class of apparatus, such as electrometer, receiver, air pump, telescope, microscope, gasometer, &c. (All the apparatus attendant upon experimental science and art will be found under the name by which such is generally known.)

APPARENT. In astronomy and mathematics, denotes things as they appear to the eye, in contradistinction to their real place; thus we say, apparent place, apparent motion, apparent size, &c. The sun apparently moves from east to west daily, but in reality it is the earth which moves contrariwise. So also apparent time, indicated by a clock, often differs some minutes from true time, as indicated by the sun. The true position of a heavenly body differs from the apparent one, because the light from it takes some time to pass thence to us, and this must be allowed for.

APPARITION. In astronomy, denotes stars or other luminaries becoming visible, after having been hid, as in a transit.

APPENDAGE. Any thing attendant upon another, as the minor details of a machine are appendages to the main body of it.

APPLICATE. (See *Ordinate*.)

APPROACH, the Curve of. A curve of such a nature, that a body rolling down it approaches the bottom, by passing over equal spaces in equal times.

APPROXIMATION. In mathematics, a term used to signify a continual approach to a quantity required, when no process is known of arriving at it exactly. Thus, the square root of 2 cannot be found exactly, yet so nearly that its approximate value may be used even in the nicest calculations. This process is the basis of many calculations in mathematics, and of great importance in numerous practical operations.

APRON. In gunnery, a piece of lead used to cover the touch-hole of a cannon.

APRON. In plumbing. (See *Flashing*.)

APRON. In engineering, is a platform, or flooring of plank raised at the entrance of a lock, or beneath flood and lock gates.

APRON PIECE, or PITCHING PIECE, a horizontal piece of timber in a wooden double-flighted stair, for supporting the carriage pieces, or rough strings and joistings, in the landings.

APRON. In ship-building, a piece of curved timber fixed behind the lower part of the stem, immediately above the foremost end of the keel.

APPULSE. So near an approach of two heavenly bodies to each other, as to be seen by the same telescope at the same time.

APSE. **APSES.** A semi-circular or angular termination to the choir, aisles, or other part of a church. Also, all recesses of these forms, if used for religious purposes, such as for monuments, altars, shrines, &c.

APSIDES. **APSES.** The orbits of all the planets are elliptical around the sun, the sun not being quite in the centre of the ellipse. The two points at each end of the ellipse are called the planet's apses; that in which the planet is nearest the sun is called its perihelion; the more distant point its aphelion. The line which connects these is called *the line of the apses*. The same occurs in the moon's passage around the earth, except that the two apses are called the *perigee* and *apogee*.

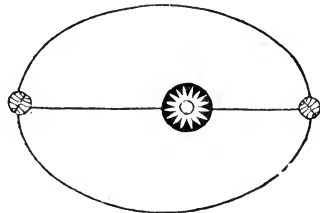

APSIDES, Motion of the. The last figure will exemplify this, supposing the oval, which represents the earth's orbit, to turn round the centre of the sun slowly, the line of the apses would of course take a different direction each succeeding moment, until a complete revolution had been made, and the line of the apses stood as at first. There is such a motion in the apses of all the planets, arising from the disturbance which they occasion to each other's motions, owing to the relative positions of their respective orbits. The motion of the apses is so slow, that it requires more than 109,830 years for the apses of the earth to make a single sidereal revolution, or to recover its place again among the stars.

APTERAL TEMPLE. One without columns on either side.

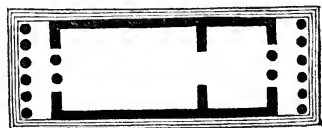

APYROUS. Refractory in the fire, applied to those bodies which remain long in a state of incandescence without change.

AQUA-FORTIS. The old and still popular name for nitric acid. There are two kinds in ordinary use, one called simply aqua-fortis, which is about a quarter the strength of nitric acid, and double aqua-fortis, which is, as its name implies, double the strength of the common kind. It is used in numerous metallurgical processes, particularly by workers in brass and copper, by whom it is known by the name of *pickle*. Engravers employ it wherewith to etch their copper and steel plates, after the lines have been traced through the etching ground. (See *Biting-In*.)

AQUA-MARINA. Synonymous with beryl. The name of a precious stone of a bluish green color.

AQUA-REGIA. A mixture of 2 parts nitric, and 1 of hydrochloric acid; used for the solution of gold, platinum, and other stubborn metals. It is now called nitro-muriatic or nitro-chloric acid.

AQUA-TINTA. A species of engraving on copper or steel, imitating Indian ink drawings. The outlines of the figure are first etched, in the usual manner, upon a sheet of copper or steel; then a solution of mastic or rosin in spirits of wine is thrown over it; the spirits of wine evaporating, leaves the mastic or rosin in minute specks; acid being poured on the plate, bites in the interstices between the particles of rosin. The lighter parts, when bitten enough, are stopped up with a varnish, and the process continued only of the rest, until by frequently stopping out one part after another, the requisite effect is produced. According to the strength of the solution of rosin, so the specks deposited by the evaporation of the spirit will be larger or smaller, and thus such a coarseness or fineness of grain may be given to the work as may be desired.

AQUA-TOFANA. A poisonous liquid, which excited extraordinary attention in Naples, in the 17th and 18th centuries. Tofana, a Sicilian woman, seems to have invented it; it is said that she poisoned some hundreds of individuals. It is described as a transparent and tasteless water, of which 5 or 6 drops were fatal, producing death slowly, without pain, inflammation, convulsions, or fever. It seems to have been a solution of crystallized arsenic, with probably something added.

AQUA VITÆ. Any strong ardent spirit, particularly applied to brandy.

AQUARIUS. The eleventh sign of the zodiac, into which the sun enters on the 19th day of January, and leaves on the 18th day of February. It is emblematic of the winter season, or rather the rainy season, such in the hotter countries being equivalent to the winter of the north.

AQUEDUCT. An artificial conduit or canal for the conveyance of water from one place

to another. The Roman aqueducts are still celebrated. They were built in the same manner as such of our railways as are upon arches.

ARABEOUS. Any thing composed of, or similar to water; in painting any nearly colorless transparent tint is so called.

ARABESQUE. MORESQUE. Any fanciful enrichment used upon flat surfaces, consisting of interlacing foliage, scrolls, network, &c., extremely common in the Moorish buildings, and used by us in endless varieties in paper-hangings, carved work, paintings of borders, interiors, &c. The iron gates of the triumphal arch at the corner of the Green Park, London, is a fine specimen of the arabesque ornament. No figures of animals are seen in true arabesque work. (See *Scroll, Antique, and Grottesque Ornament*.) The heading of this book, as well as many of the initial letters, show different styles of arabesque, grotesque, and fret ornament. Letter A is from an illuminated manuscript of 1546.

ARABIC GUM. A gum which flows naturally from different species of the acacia, the plum-tree tribe, &c. It is of considerable value for stiffening various fabrics, such as bonnets, lace, linens, &c., and for numerous other purposes in the arts.

ARABIN. The chemical principle which forms the basis of all gums. It is composed of

Carbon	43·81	} 100.
Oxygen	49·85	
Hydrogen	6·2	
Azote	·14	

ARABLE LANDS. Such as are cultivated by the plough, in distinction to pasture lands.

ARABO-TEDESCO. A style of architecture exhibiting a mixture of the Moorish or low Grecian, with the German Gothic. Of this style is the Baptista at Pisa, erected in 1152. The lower story is a Corinthian arcade, the upper Gothic, with pinnacles and sharp pediments adorned with trefoil ornaments.

ARÆOSTYLE. A term employed by Vitruvius to signify an inter-columniation, equal to four diameters of the column, which is the greatest space possible consistent with security. It is only applicable at all to Tuscan buildings.

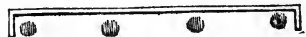

ARÆOSYSTYLOS. That style of building in which four columns are used in the space of 8 diameter and a half, the centre inter-columniation being $3\frac{1}{2}$, and the others only a half, as is seen in the front of the Louvre at Paris, in which the columns appear in pairs.



ARAGO'S OSCILLATORY PLATE. This is the converse of the following instrument. The plate A is made of any metal, such as copper or zinc. It is balanced on its centre, but loaded with a small ball on the circumference to enable it to oscillate like a pendulum. It was found, that when this plate was put between the poles of a horse-shoe magnet, the number of oscillations which it made before being stopped by gravity, was many less than when the magnet was not present.

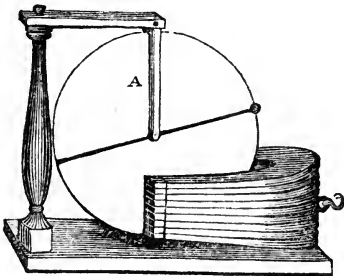

ARAGO'S REVOLVING PLATE. A circular plate of copper, made to revolve above or below a magnet, which is so suspended as to be capable of a similar motion. Its object is to show, that metals not usually magnetic, yet become so when put into rapid rotation, as is seen by their influence on a magnet placed near them.

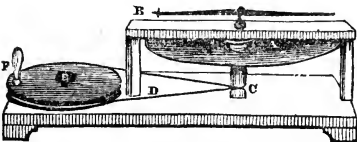

The above is a view of the apparatus. A is the plate of copper, about a foot in diameter. B a freely-suspended magnet. C, D, and E, a pulley, cord, and multiplying wheel, to communicate motion to the copper-plate. When the handle F is turned, and the copper-plate is made to revolve, the magnet revolves also; and not because of the impulse of the air, for it works in the same manner when a sheet of glass intervenes between them. The plate need not be copper, M. Arago says, that all metals, solids, fluids, and even gases, will produce some effect, though the intensity is in proportion to the nature of the substance.

ARBOR. The axle or spindle on which a wheel turns.

ARBOR CHUCK. A chuck, consisting of merely a spindle or arbor, generally of metal, projecting from the mandril of the lathe. It

is useful in turning and polishing rings, hollow cylinders, and other objects that may be driven over it.



ARBORESCENT. Growing like the branches of a tree; as an arborescent plant, an arborescent mineral; sometimes synonymous with dendritic.

ARBOR DIANÆ, or SILVER TREE. An arborescent deposition of silver; it may be formed thus—Pour upon mercury in a saucer a little of the solution of nitrate of silver. After some hours the silver will separate, and lay upon the surface of the mercury in a beautiful series of crystals, resembling the ramified divisions of a tree.

ARC. Any portion of the circumference of a circle measured in degrees.

ARC OF THE MERIDIAN. Any part of the earth's surface, considered in reference to a meridian, or a line running from north to south. The measurement of an arc of one degree, in different parts, enables the astronomer to ascertain the precise form of the earth. Were it exactly globular a section of it would be a circle, and every one of its 360° exactly equal to the rest, because all lines drawn perpendicular to the earth's surface would meet in the centre; but lines drawn perpendicular to the surface of an ellipse, or spheroid, do not meet in the centre, but each adjacent pair in a point different from the next pair. The angle which any two of them makes, being measured, gives the length of the arc at that particular part of the surface.

ARCADE. A series of arches, supported upon piers or columns, either open, or closed with masonry; frequently used to decorate the walls of Norman churches, both externally and internally.

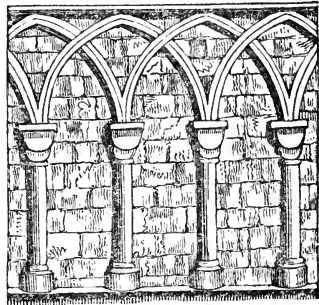

Lately there have been erected in some of our cities ranges of shops, so inclosed as to

form a covered line, and to which this name has been given.

ARCANUM. A secret, particularly a secret recipe, or remedy.

ARCH. A construction of stone, brick, iron, &c., so contrived as to throw any weight above it upon the lateral abutments. The component parts of an arch are its *supports*, which may be abutments, piers, or columns, A A. The square stone, or stones, capping these, is called the *impost*, or *platband*, B B, immediately above which are the *springers*, C C. All the stones in the curvature are named *arch stones*, D D, while the centre of all, and which knits them together at the top, is the *key stone*, E. The under surface is the *intrados*, or *soffit*, and the upper line the *extrados*. The walls between the crown of the springing, are the *haunches*, *flanks*, or *span-drills*, F F. The width from the inside of one springer to the inside of the other is the *span* or *chord* of the arch, G.

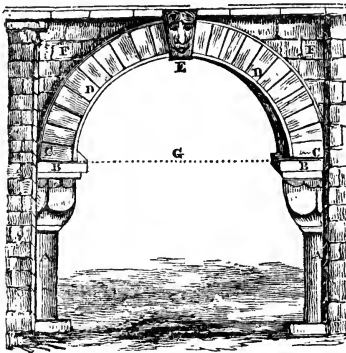

It is supposed that the principle of the arch was quite unknown till near the time of the Christian æra, no remains existing to show that either the Greeks, Indians, or Egyptians, were acquainted with it. In the very ancient buildings, such as Stonehenge,

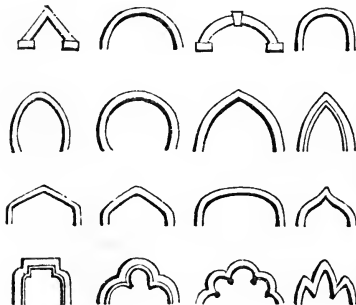

a flat stone laid across two uprights was used over openings in walls. Among the Saxons two stones were sometimes used, forming a triangular straight-sided arch. After which time it gradually, and in different countries, assumed various forms, according to the style of architecture of the buildings in which it appeared. The preceding cut represents some of these varieties.

ARCH, Recessed or Compound. Consists of a number of concentric archways, placed within and behind each other, as is common in the Norman and Saxon buildings.

ARCH, Triumphal. A building of which an arch is the principal feature, and designed to commemorate the achievements of eminent or illustrious persons. There are two or three celebrated triumphal arches at Rome; one dedicated to Titus, and another to Constantine. Hadrian's at Athens is another beautiful example.

ARCH BUTTRESS. ARCH BUTMENT. Synonymous with flying buttress; but the term is only used when several flying buttresses unite to support a vault, spire, &c., as in the church of St. Dunstan's in the East, London.

ARCHETYPE. An original design from which a piece of art is to be executed.

ARCHIL. A whitish branched lichen, growing upon rocks in Portland Island, and more plentifully in the Canary and Cape Verde Islands, whence we receive it as gathered. When bruised and mixed with urine, it acquires after some time a purplish red color, called then orchil; after a few days it becomes blue, in which state it is called litmus, a beautiful color, but fleeting, both when exposed to the air, and excluded from it. Hence the dyers use it only to give a bloom to pink and similar colors. It affords, however, a durable scarlet color, by the addition of a solution of a salt of tin. The spirit in thermometer tubes is stained with archil, so are various articles of furniture; and litmus affords to the chemist the most valuable test for acids.

ARCHIMEDES' SCREW. A machine for raising water; it is represented and described as follows:—

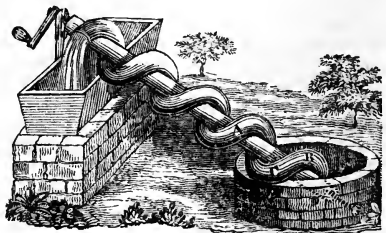

A is a hollow pipe, coiled around a cylindrical axis; which axis is inclined at an angle

with the ground, and supported at each end upon pivots, the upper pivot being furnished with a handle. When this is turned round, the lower end of the pipe dips into the water in the well below, and turning upwards directly scoops up some of the water. When the end points up, the part B will become lower than it, therefore the water will fall to B. Another half turn of the handle brings C to the lowest point, and the first water will occupy that part of the tube; at the same time more water will be scooped up at the end. In a number of turns of the handle, equal to that of the coils of the tube, the first water will reach, and flow out at the top; and from that time a flow will take place at every revolution of the machine.

ARCHITECTURE. The art of designing and constructing edifices of magnitude, whether civil or military. The former of which classes may be either sacred, municipal, domestic, monumental, or relative to bridges and other similar structures. The essentials of architecture are utility, strength, and beauty. Of the most ancient edifices those alone remain, the strength and solidity of which are enormous. Some of them, as the numerous druidical ruins, show massiveness alone; others, as the buildings of Thebes, and the caves of Ellora, are carefully, though rudely sculptured. The classical remains of Greece first show the quality of strength combined with grandeur of outline and delicacy of enrichment. The different necessities of the religion and habits of nations, their state and degree of civilization, and the variations of climate, have occasioned numerous *styles* of architecture, and some of these *styles* have, by the progress of knowledge and refinement, been divided into several orders, each of which, no less than the style itself, is distinguished by its appropriate proportions and decorations. (See *Doric, Tuscan, Ionic, Corinthian, Composite, Gothic, Elizabethan, &c. &c.*)

ARCHITRAVE. That part of a building, immediately above and resting upon the columns; likewise called epistyle. It also signifies the exterior mouldings to the outer curve of an arch.

ARCHITRAVE CORNICE. An entablature, consisting of an architrave, crowned with a cornice, without the intervention of a frieze.

ARCHIVE. A chamber or apartment in which records are kept, and also the documents themselves.

ARCHIVOLT. The inner curve of an arch from impost to impost. The under-surface, if quite flat, is called *soffit*.

ARCOGRAPH. Any instrument adapted to draw a circular arc, without the use of a central point. The following simple instrument is very convenient in drawing upon paper the large curves for bridges, elliptical arches,

the circular lines upon maps, &c. It consists of a piece of wood, shaped like A. It may be 1 or 2 feet long, and half an inch thick. In the centre of this is a long thumb screw C, the head of which does not exceed in diameter the thickness of the wood through which it passes. At or near the ends of A are two square staples, projecting half an inch above the upper face. B is a thin flexible strip of wood or metal, working in the two staples, and curved to any required degree by the screw C, which presses against it. In order that the flexure may be equable and regular, the strip of wood B should be slightly thicker towards the middle of it than at the sides. The manner of using the instrument will be obvious.

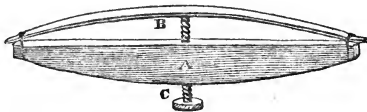

The following method is often practised by masons in striking a curve on a wall:—Drive two nails into the wall, at the ends or springing of the curve. Then nail two rods or laths together at such an angle, that when the sides of the rods touch the nails, the top of them shall touch the crown of the arc. Then hold a pencil, or piece of chalk, at this point, and by moving the rods backwards and forwards, still keeping the sides of them in contact with the nails, the required curve will be described.

ARCTIC. That part of the world towards the northern or arctic pole, as the arctic ocean, &c.

ARCTIC CIRCLE. An imaginary circle on the globe, parallel to the equator, and at the distance of 23° 28' from the north pole; it is also called the north polar circle, and separates the north frigid from the north temperate zone.

ARDENT SPIRIT. Any strong intoxicating liquid, whether spirits of wine, brandy whiskey, or any other.

AREA. The space contained within the boundaries of any thing, without regard to thickness. The area of a plane figure is estimated by the number of little square spaces that may be contained in it; each of these spaces being of a certain size, as a yard, a foot, an inch, measured on the side. In building it is an inclosed space exposed to the air.

ARENA. The ground floor or area of an amphitheatre, within the seats for spectators.

AREOMETRY. The science of measuring the gravity of fluids.

AREAL. Crude tartar, as it is taken from the wine casks.

AREOMETER. An instrument for taking the specific gravity of liquids. The following cheap and very sensitive areometer is the invention of a M. de Parcieux, of Paris. It consists of a glass phial, corked tight, into the cork of which is fixed a perfectly-straight wire, or thin rod of wood, about 2 feet long. The phial is loaded with shot, so as to make it sink in the heaviest liquor to be examined, so much as just to immerse the phial itself to a certain mark made near the lower part of the wire. In addition to this, there is a cylindrical glass tube in which the liquor to be tested is to be placed, which must have a scale of equal parts marked on the side, and which indicate the depth at which the point of the wire falls, according to the specific gravity of the fluid in the glass tube. This instrument is said to be so very sensitive, that, if adjusted to cold water, and then exposed to the rays of the sun for a few minutes, the small degree of heat imbibed, and consequently the small difference of specific gravity will occasion a sinking of the phial some inches. A pinch of salt, or sugar, thrown in makes it rise some inches, and a little spirits poured in makes it sink. With one of the instruments, weighing somewhat less than 24 ounces, and plunged in water, there is a rise or fall of above half an inch for every 1-17424th part of the water displaced, so that a difference of a hundred thousandth part is easily perceived.



ARGAND BURNER. A lamp burner through the centre of which the air is enabled to pass, as in the common table lamps, gas burners, &c.

ARGENTATE OF AMMONIA. Ammoniuret of silver.

ARGENTO-CYANATE OF POTASS. The fulminate of potass.

ARGENTO-CYANIC ACID. This supposed acid is the bi-fulminate of silver.

ARGENTUM. The Latin word for silver.

ARIES. The Ram. One of the twelve signs of the zodiac, in which the sun enters on March 21st, and leaves on the 20th of April, the former of which times is that of the vernal equinox. In the ancient military art it signified a battering ram, with which the walls of cities, &c., were assailed.

ARITHMETIC teaches to compute or calculate by means of numbers. It is both a science and an art; a science inasmuch as its various operations are dependent upon fixed mathematical principles, and an art because these principles are only applicable to the purposes of life by the aid of manual dexterity. It is divided into vulgar, decimal, and fractional. The first treats of whole or

complete numbers, in their various combinations, relations, and proportions. The second supposes the complete number to be attended by parts or portions of a number, and these portions being the relation of tenths, hundredths, &c., to a unit or one. (See *Decimal*.) The third also supposes parts of a number to be attached to the principal, but these parts are in the form of a vulgar fraction, (which see.) All operations in arithmetic may be said to consist entirely of the rules of addition, subtraction, multiplication, and division. The only characters absolutely necessary are the ten digits, 1, 2, 3, 4, 5, 6, 7, 8, 9, 0.

ARITHMETICAL PROGRESSION. (See *Progression*.)

ARM. The length of a sail of a windmill measured from the axis.

ARMS of an Axle. The two ends of an axle-tree. Projecting supports in machinery.

ARMILLARY SPHERE. An artificial globe, composed of circles and rims of brass or wood, to represent the imaginary circles on the earth and in the heavens, such as the horizon, the zodiac, the meridians, &c. It has the same motions on its axis and at its supports as the usual artificial globes.

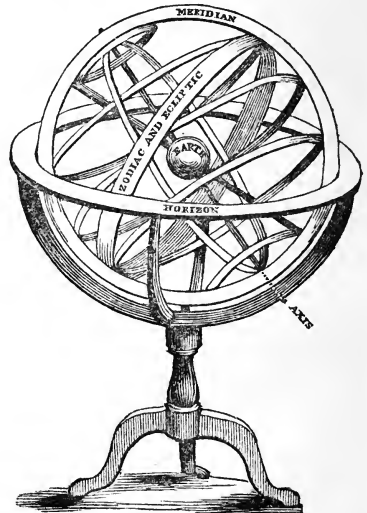

ARMENIAN CEMENT, or TURKISH GLUE, used for mending glass, jewellery, &c., is made by dissolving isinglass in brandy, or spirits of wine, and adding to it an equal bulk of thick mastic spirit varnish. When made it should be as thick as common glue.

ARNATTA. ARNOTTO. A coloring material, formed from the red pulp which surrounds the seeds of the *bixa orellana*, a West Indian plant. It was once much used

by the dyers, but is not now much esteemed. Gloucester cheese is colored with it, and in Holland butter also.

ARMATURE. The piece or pieces of soft iron that are used to connect together the poles of a magnet, in order that the magnetic fluid may circulate from one pole to the other; and that thus the magnets may remain unimpaired by time or keeping, (No. 1.) In a magneto-electric engine the armature is of a more complicated form, consisting of iron reels, wound round with covered wire, (No.2.)

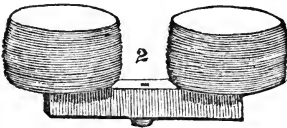
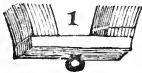

ARNOLD'S COMPENSATION BALANCE. A balance wheel of a watch or chronometer, so contrived as to expand or contract, according to the temperature to which it may be exposed, and thus enabling the chronometer to keep exactly the same rate of going in all climate.

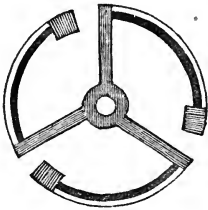

The rim of this balance, instead of being composed of a solid ring of steel, as in the common balance wheel, consists of three arcs, each composed of two strips of different metals, one of them steel, the other an alloy of zinc and silver, or of brass. The adjustment of these metals is such, that the expansibility of one shall counteract the expansibility of the other, and a perfect uniformity of size in the balance; and, consequently, in the rate of going of the instrument, be preserved in all degrees of heat and cold. The use of the weights is that the momentum shall reside in the rim of the wheel.

ARNOTT'S STOVE. An inclosed fire place, which communicates heat to the surrounding air by radiation, it being filled with heated air and heated smoke, passing from or through the fire, and filling an air jacket or chamber,

the outer case of which becomes hot by this means. Its structure is as follows:—

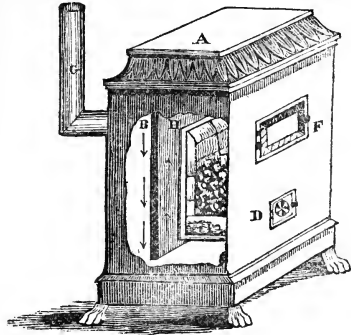

A is the outer case of sheet or cast iron, divided into two chambers by the partition B C, which is open at top and bottom. D is the door of the ash-pit, containing a register for the admission of air to support the combustion. E the fire-box, which, that it may retain its heat the better, is lined with fire brick. F the hole to admit the fuel. G the chimney. When a fire is lighted, and the doors closed, the chamber H becomes hot by the air direct from the fire. The back chamber is not so heated, and never becomes so, being separated from the direct action of the fire; therefore a strong current or circulation of hot air is kept up in the direction indicated by the arrows, and this in its passage imparts to the surrounding case nearly all its caloric, before it passes out by the chimney.

AROMA. A general term for all powerful and pleasant odours, such as the aroma of the rose, the cinnamon, &c.

AROMATIC VINEGAR. Acetic acid, scented with camphor, oils of cloves, lavender, and rosemary.

ARRACK. A spirituous liquor, distilled from rice, and also from the juice of the palm tree.

ARRIS. The edge or external angle at which two sides or surfaces meet.

ARRIS FILLET. A slight piece of timber used in raising the slates around chimneys, sky-lights, &c., that the water may be better thrown off; when placed at the eaves it is called the eaves-board.

ARROW. A missile to be discharged from a bow. In land surveying an arrow is one of the wires used to indicate the number of chains in length measured; also the mark



put upon military and government stores is called a broad arrow, or broad ar.

ARROW-HEADED CHARACTER. A written language, used by the Babylonians and Persepolitans, and of which we have many specimens remaining in the bricks and stones brought from Babylon and the neighbouring parts of the East. One of the most perfect of these is in the museum of the East-India Company, and of which inscription the following is a part, the characters being engraved of the same size as in the original. The meaning of them is totally unknown.

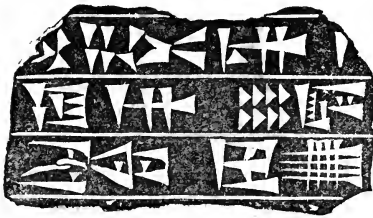

ARROW ROOT. The fecula or starch which composes the root of different species of the maranta. It grows both in the East and West Indies, Brazil, &c. The better samples are used as food, the commoner in many of the textile arts, as a dressing. Potatoe starch has the same properties.

ARSENIATES. Salts of arsenic acid, with the alkalis and metallic oxides.

ARSENIC. A brittle, whitish metal, very fusible, and volatilized at 356° Fah., with a smell like that of garlic. It is obtained from numberless minerals, and is used for the preparation of Scheele's green, realgar, and orpiment; to promote the ready fusion of numerous metals; and in the manufacture of shot, in order to assist its better granulation. Arsenic unites with oxygen, chlorine, hydrogen, sulphur, phosphorus, &c.

ARSENIC ACID. A white powder, with acid properties, consisting of 1 part metallic arsenic, and 2½ oxygen. Soluble in 6 parts of cold, and 2 of boiling water. Its solution tastes sour and metallic. It may be procured by distilling nitric acid off metallic arsenic.

ARSENICAL SOAP. A preparation used to anoint the skins of animals during the process of preparing and stuffing them for the museum. The composition of that of the inventor, M. Becoer, is as follows:—

Arsenic in powder	2 ounces.
Camphor	5 drams.
White Soap	2 ounces.
Salt of Tartar	12 drams.
Powdered Lime	4 drams.

ARSENIOUS ACID. White arsenic. White oxide of arsenic is composed of arsenic 1 part, oxygen 1½; is barely soluble in water, tasteless, and violently poisonous. It may be procured by sublimation from the metal.

ARSENIO-SULPHURETS. Compounds of the arsenical sulphurets with the alkaline sulphurets, divided into arsenio proto-sulphurets, or such as have the proto-sulphuret of arsenic, (realgar,) in their composition. Arsenio sesqui-sulphurets, containing orpiment or sesqui-sulphuret of arsenic, and arsenio-persulphate, containing the per-sulphuret of arsenic.

ARSENITES. Compounds of arsenious acid and various bases. The chief arsenite used in the arts is Scheele's green, which is an arsenite of copper, procured by precipitation from the sulphate of copper.

ARSENIURETS. Combinations of arsenic with metallic and other bases.

ARSENIURETTED HYDROGEN GAS. A fetid gas, sparingly absorbed by water, and not capable of supporting combustion, therefore poisonous. It is decomposed by most of the metallic oxides and salts, by nitric acid, and by phosphorus, sulphur, &c., at a high temperature. It may be procured by boiling muriatic acid on an alloy of equal weights of arsenic and zinc; or one of 3 parts tin, and 1 arsenic.

ART. A process dependent either upon genius, taste, or manual dexterity. According as one or other of these is most requisite, so the process belongs to one of the three principal divisions of art, the *fine*, the *ornamental*, and the *mechanical*. These two last sections are often combined under the general denomination of the *useful* arts. Logic, rhetoric, oratory, geometry, &c., have been styled the *liberal* arts. The processes used in the preparation of food, and for the comfort of a household are called the *domestic* arts. The manufactures dependent upon chemistry are called the *chemical* arts, while numerous others cannot conveniently be classed with either of the above, except the useful, nor yet with each other, as the art of gardening, &c.

ARTESIAN WELLS. A name given by the French, and extensively adopted here, to such artificial fountains as are made by boring the earth, and allowing the water to rise.

ARTHANATINE. A crystalline matter, obtained by alcohol from cyclamen roots.

ARTIFICIAL. Any thing made by art. The term is generally applied to such objects as are intended to represent others which are natural. Thus we speak of artificial flowers, fruit, crystals, &c.; or it may signify a spurious imitation of a superior-manufactured article, or a weak attempt at superior excellence in mind, style, &c. as is exemplified in such expressions as artificial gold, artificial manners, &c.

ARTIFICIAL GLOBE. (See *Globe*.)

ARTIFICIAL MAGNETS. (See *Magnets*.)

ARTIFICIAL COBWEBS. Exceedingly fine

threads, made of Indian rubber by drawing out its solution, (obtained by turpentine,) as fine as possible. The reason of the name is, because these threads are used instead of spider's webs for micrometers.

ARUNDELIAN MARBLES. Ancient marbles, illustrative of the mythology and history of the ancients, so called from the Earl of Arundel, by whom they were obtained from the Isle of Pharos. In 1667 they were presented to the University of Oxford by his grandson. They contain a chronicle of the city of Athens, supposed to have been inscribed thereon 264 years before Christ.

ASARIN. A principle extracted from the asarum europœum, or assarabacca.

ASBESTOS. A fibrous flexible mineral, indestructible in the fire, of which there are five varieties. *Amianthus*, which occurs in soft, white, long, and silky filaments, from which the ancients made cloths, in which bodies for the funeral pile were wrapped; also, dresses have lately been made of it, for the use of firemen in entering burning houses, &c. *Common asbestos* is inferior to, but resembles the above, except in being less flexible, and twice as heavy. *Mountain leather*, consists of fibres so intermixed as to resemble leather; when in very thin pieces it is called *mountain paper*. *Mountain cork*, or *elastic asbestos*, is like the last, but less compact: it swims on water. *Mountain wood*, *ligniform asbestos*, differs in no degree from the preceding, except in being harder, of a bronze color, and having the aspect of wood.

ASCENDING. In astronomy, is said of such stars as are rising above the horizon in any parallel of the equator.

ASCENDING LATITUDE. The latitude of a planet when going towards the north pole.

ASCENDING NODE. That point of a planet's orbit wherein it passes the ecliptic to proceed northwards.

ASCENSION. In astronomy, is either *right* or *oblique*. Right ascension, as of a star, is that degree of the equator, reckoning from the beginning of Aries, which comes to the meridian with the star. The oblique ascension is that degree of the equator, reckoning as before, which *rises* with the star. By the right ascension and declination we are enabled to find the position of stars in the heavens; in the same manner as places on the earth are found, by noticing their latitude and longitude.

ASCENSIONAL DIFFERENCE. The difference between the oblique and right ascension in any point of the heavens.

ASH. The wood of the *fraxinus excelsior*, or ash tree, valuable for its toughness, strength, elasticity, and straight grain, while kept dry for its durability, therefore much used for wheel-work, carriages, agricultural

implements, and the handles of tools. The young wood is equally valuable with the old.

ASHES. The incombustible whitish powdery material remaining after the burning of organic matter, and also certain mineral substances. The ashes of vegetable substances are mostly impregnated with alkali; that produced by the burning of sea plants being impregnated with soda; that from terrestrial vegetables with potass, in both instances combined with carbonic acid and much earthy matter. Coals, bitumen, &c. are void of these alkalies, but yield ammonia and other products, during their distillation, and leave an earthy slag, which still more burnt changes into an inert grey ash. The ashes of animal remains, particularly those from bones, are totally different in their nature, composed chiefly of phosphoric acid and lime, in the combined state of phosphate of lime.

ASHLAR. Hewn stone, used for the facings of walls; when smoothed, it is called *plane ashlar*; when wrought into regular flutes, it is *tooled ashlar*; when cut without regularity, it is said to be *random tooled*; when wrought with a narrow tool, it is called *chiselled* or *boasted*; and when with a tool still narrower, it is said to be *pointed*; when the grooves are sunk by cutting the arrises off the stones, the work is said to be *rusticated*; and when pitted into deep holes, it is called *prison rustic*.

ASH-HOLE. The receptacle for the ashes of a furnace.

ASHLERING. Setting an ashlar facing; or by carpenters, it is the fixing of upright quarterings between the rafters and floors of garrets, in order to make more convenient rooms, by cutting off the acute angles at the bottom.

ASPARAGIN. A vegetable principle, discovered in the juice of asparagus, the mallow, and other plants. When the juice of these is concentrated by evaporation, crystals spontaneously separate. This substance appears to consist of hydrogen, oxygen, carbon, and nitrogen, but contains neither earth nor alkali. It is white, transparent, slightly nauseous and cool to the taste, and soluble in water.

ASPARTIC ACID. An acid procured from asparagin.

ASPHALTE. A bituminous stone, found in many parts of the continent, particularly Germany and Prussia; much used by the ancients as a cement in building, and lately employed by us instead of paving, and for covering roofs, &c. It is prepared for use thus:—94 parts by weight of the asphaltic stone pulverized, are mixed with 6 parts of bitumen or tar, and melted down; when melted it is merely poured upon the part prepared to receive it, and scraped and

beaten smooth while in a hot state; for pavements fine river sand is mixed with it.

ASPHALTIC MASTIC. The same as asphalte.

ASPHALTUM, called also mineral pitch, Jew's pitch, and bitumen. A hard, shining, pitch-like substance, found in Judea, America, China, &c. Anciently employed in embalming dead bodies, and instead of mortar in building; now used in numerous black varnishes, and engravers' etching ground, &c. &c.

ASPHYXIATING GASES. Such gases as are hurtful when inhaled, not because they themselves contain a poisonous principle, but because they are not oxygen. They are nitrogen, hydrogen, carbonic oxyde, protoxide of nitrogen, &c.

ASSA FŒTIDA. The inspissated juice of an umbelliferous plant, found in several parts of Asia. It is of a most powerful and foetid scent, and is used in medicine.

ASSAY, OR ASSAYING. A chemical analysis to ascertain the quantity of gold and silver in a metallic mass. In its more extended meaning it is used for the determination of the quantity of any metal whatever, in composition with any other metal, or mineral.

ASSAY BALANCE. An extremely delicate balance, employed for determining with great precision the weight of minute bodies. It differs in external form in no respect from the common scales; but in order to ensure the greatest possible delicacy, the beam is made very light, and supported at the centre upon a sharp edge of steel, with a piece of agate let into the beam for it to rest upon. The scales are also supported upon two steel edges, one crossing the other at right angles, so that there is the least possible friction. Some balances have been constructed of such delicacy, as to turn with a millionth part of the weight they were loaded with.

ASSER. An old word for a thin rafter, board, or lath of wood, used for the roof of a building.

ASTATIC. Without polarity. The term is applied to a magnetic needle, when so constructed as not to turn to the pole of the earth. It consists of two magnets united to each other, so that the north pole of one shall be opposite or near to the south pole of the other, while the natural polarity of one is counteracted by that of the other, and the compound needle therefore is void of spontaneous direction—a circumstance of the utmost consequence in electro-magnetic experiments.

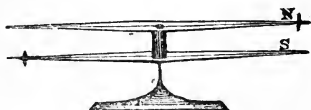

ASTEROIDS. The last discovered and small planets, Ceres, Juno, Pallas, and Vesta.

ASTRAGAL. A small round fillet or moulding, encircling a column. In the more ornamented orders it forms the hypertrachelium; that is, the upper part of all, between the shaft and the capital. The same name applies to the semi-circular moulding, sometimes cut into beads and berries, that separates the different faces of an architrave.



ASTRINGENT. Any substance possessed of a peculiar, rough, austere taste, such as oak bark, willow bark, nut galls, new port wine, many unripe fruits, &c. The commoner astringents are used in the art of tanning, and therefore their active principle is called tannin.

ASTRINGENT PRINCIPLE. Another name for tannin.

ASTROGNOSY. The science which teaches the constellations, ranks, &c., of the stars.

ASTROLAB. An ancient astronomical instrument, used for taking the angle of altitude, and position of the stars, and equally applicable to take angles generally. The following was its form:

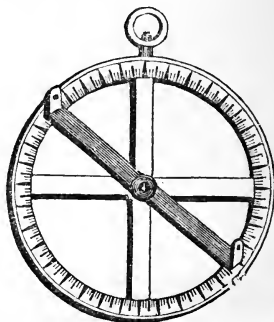

ASTROLOGY. An art which pretends to foretell future events, especially the fate of man, from the aspect of the stars at the period of his birth.

ASTRONOMY. The science which explains the form, size, position, and motions of the heavenly bodies, and their mutual influences and disturbances. It is a science essentially of observation and rigid mathematical calculation. (See *Heavenly Bodies, Solar System, Planet, Star, Comet, &c.*)

ASTRONOMICAL HORIZON. (See *Horizon.*)
ASTRONOMICAL TELESCOPE. Forms a part of most astronomical observatory instruments; to obtain one of the highest degree

of perfection is of the greatest importance. Astronomical telescopes are made upon different principles, as is explained under the words *Telescope*, *Amici*, *Newton*, &c. &c. In the usual instruments the lenses are according to the following arrangement:—

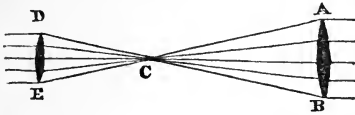

A B represents the object glass, which is a double convex lens, placed at the larger end of the telescope tube or case; D E the eye-glass, which is also a double-convex lens, placed at the smaller end of the tube; (in the best instruments, instead of each of these glasses are two lenses, that the chromatic aberration may be corrected.) The rays of light from the distant star or planet strikes the object glass. The rays, before parallel, are refracted to a focus in C. From this point they again diverge till they strike the lens D E, when they again become parallel, and in this state enter the eye. Owing to there being but two glasses, every object will appear to the eye inverted, for the ray of light from the top of the object strikes the object lens at A, and proceeding onwards arrives at the eye-piece at E—the lower portion of it. This is of no consequence in viewing the celestial bodies. Common astronomical telescopes usually magnify from 70 to 100 times; the better instruments sometimes as much as 3 or 400 times. There is always a very great difference in size between the object and eye-glasses of an astronomical telescope, in order that the former may take in as large a field of view as possible, and with it absorb a proportionate quantity of light, which being gradually condensed, comes to the eye in a very concentrated state, so as to show the object with considerable brilliancy.

ASTRONOMICAL SYMBOLS are as follows:

Signs of the Zodiac.

♈ Aries.	♎ Libra.
♉ Taurus.	♏ Scorpio.
♊ Gemini.	♐ Sagittarius.
♌ Cancer.	♑ Capricornus.
♍ Leo.	♒ Aquarius.
♎ Virgo.	♓ Pisces.

The Heavenly Bodies, &c.

☉ The Sun.	♂ Mars.
☾ Moon.	♃ Jupiter.
☽ New Moon	♄ Saturn.
☾ First Quarter.	♁ Herschel.
☽ Full Moon.	♁ Ceres.
☾ Last Quarter.	♁ Pallas.
☿ Mercury.	♃ Juno.
♀ Venus.	♁ Vesta.
♁ The Earth.	★ A Star.

♁ The Dragon's Head, or Ascending Node.
 ♁ The Dragon's Tail, or Descending Node.
 ☾ Conjunction. ☽ Opposition.
 △ Trine. □ Quadril. ✕ Sextil.

ASTRONOMICAL DAY, begins at twelve o'clock at noon, and counts twenty-four hours round. It is twelve hours later than the civil day. Thus the first twelve hours of the astronomical 1st of January, would agree with the hours from noon to midnight of the same common day; while twelve o'clock in the morning of our January 2nd would make up the rest of the astronomical day, and would be called 13 o'clock, or 13 hours, 14 hours, and so on to noon again.

ASTROSCOPE. An ancient astronomical instrument, consisting of two cones, upon which the constellations were depicted, in the same manner as they are now upon the celestial globe.

ASYMPTOTES. (See *Hyperbola*.)

ATHANOR. An ancient alchemical furnace, adapted to supply itself with the requisite quantity of fuel for a long period. It differed from modern contrivances only, in having a pipe above the fire filled with charcoal, which fell down as the fire made room for it. The top of the tube being closed, the fuel did not ignite till wanted.

ATLANTES, or PERSIANS. Male figures used in the place of columns, to support entablatures, &c. The female figures are called caryatides.

ATMOMETER. An instrument invented by Professor Leslie, to ascertain the exhalation of a given vaporable substance in a given time. It consists of a hollow ball of porous earthenware, 2 or 3 inches in circumference, with a small neck, into which is cemented a graduated glass tube, closed at the top with a brass screw; this instrument is filled with water or other liquid, the cap screwed on tight, and then the whole hung in the sun or air; according to the sinking of the water in the graduated tube, so is the evaporation to be allowed for.

ATMOSPHERE. The sphere of air which surrounds the earth. Its *height*, taken as that where light ceases to be reflected, is understood to be between 40 and 50 miles. Its weight and pressure are dependent upon its altitude above the surface; decreasing upwards, on the surface of the earth it is, at an average, 15 pounds to the square inch, and as fluids press equally in all directions, according to their heights, the same pressure is exerted on every inch of the surface of every body on the globe to which the atmosphere has access. As it is supposed that the sun, moon, &c. are equally surrounded, we speak of the sun's atmosphere, the moon's atmosphere, and so on.

ATMOSPHERES, *One, Two, &c.* The elasticity of air increases with its condensation,

and the ordinary pressure being 15 pounds on the square inch. A condensation which produces a pressure of 30 pounds on the inch is termed two atmospheres; that which gives a pressure of 45 pounds, three atmospheres, and so on. Pressures arising from other causes, such as the weight of liquids and the force of steam are counted by atmospheres.

ATMOSPHERE, ELECTRICAL. The air around any body which is electrified, and which, therefore, becomes itself electrical, and capable of electrizing all bodies which come within its sphere.

ATMOSPHERIC ELECTRICITY. That part of science which treats of the electrical appearances visible in the atmosphere, such as lightning, the aurora borealis, &c.; and also which teaches the means of guarding against accidents arising from such phenomena.

ATMOSPHERIC ENGINE. Any engine may be so called whose motive power is derived from the pressure of the atmosphere; but the term is chiefly applied to the steam engine invented by Newcomen in 1705. The construction of which will be understood by the following engraving and description:—

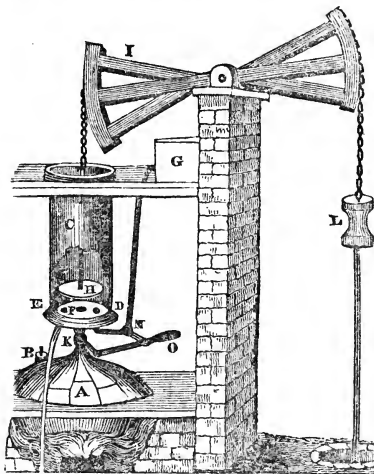

A is a boiler; B, a clack valve, as a safety valve; C, the cylinder, which has an open top, and three holes at bottom D E F; F admits the steam from the boiler through the cock K; D admits the cold water to condense with, and which passes from the cistern G, through the pipe and cock N. The hole E is connected with a long pipe, which conveys away the waste water and condensed steam; H is a piston fitting tightly into the cylinder; I the beam, connected at one side with the piston rod, and at the other with the pump rod, which bears

upon it a weight L, to counterpoise the weight of the piston on the other side, and to assist in raising it at each stroke to the top of the cylinder.

The action is this:—a boy was employed to pull and push alternately at the handle O; this works the two cocks N and K, shutting one at the same time that it opens the other; suppose then K to be open, the steam would rush through and fill the cylinder, and drive up the piston, when this is full, the boy pushed the handle forwards, shutting off the steam and admitting a jet of cold water, which condensed the steam before admitted, allowing the pressure of the atmosphere to drive down the piston which worked the pump-rod at the other end of the beam. This engine is still employed in many of the mining districts for pumping water, a rod from the beam working the cocks. The waste of steam, and consequently the expenditure of fuel is, however, very great.

ATMOSPHERIC TIDES. Certain periodic changes in the air, such as trade winds, monsoons, &c. &c.

ATOMS. The ultimate, or least conceivable principles into which a body may be divided, or of which it may consist.

ATOMIC THEORY, THE, depends upon the supposition, that all bodies are composed of ultimate atoms, the weight of which is different in different kinds of matter, according to which view every compound is formed by a combination of the atoms of its constituents. If water, for example, is composed of an atom of hydrogen and an atom of oxygen, it follows, that every other combination of hydrogen with oxygen must contain 2, 3, 4, or more atoms of oxygen; because as an atom is the least possible portion of matter, it is impossible that there can be any division of this portion.

ATOMIC WEIGHTS. Numbers intended to represent the relative weights of atoms, so as to show the exact constituents and relative proportions of them in every substance, whether simple or compound. As atoms are too minute for the real weight of them to be appreciated by balances, it is necessary to take one substance, and assign a certain value to it, and from this to calculate the atomic weights of other bodies, judging from their known effects of combination. By one class of philosophers hydrogen forms the standard or unit, by others, oxygen is so considered. (See *Scale of Chemical Equivalents*.)

ATRIUM. A hall or antichamber, usually of a large size, being used as a place of meeting, feasting, &c.; also the principal porch of a church was so called by the writers of the middle ages.

ATROPINE. The basis of the atropa belladonna, or deadly night-shade.

ATTAR OF ROSES. A concrete oil of astonishing and delightful fragrance, made from roses in India and Turkey. To produce one rupee's weight, (not half an ounce,) of attar, requires 200,000 full-blown roses. It is, therefore, extravagantly dear, being sold at the English warehouse in India at £10 for the above weight. That fragrant material sold here as attar is spermaceti scented with about a thousandth part of attar.

ATTENUATION. A making thin, applied in distillation and brewing. The specific gravity of spirit is diminished at every distillation, because of its impurities being removed; it is therefore said to be attenuated. Wort also becomes lighter during fermentation, because of the formation of a vinous spirit, and the separation of carbonic acid gas. In proportion to the perfect fermentation, therefore, the whole mass will become attenuated.

ATTIC BASE. A peculiar kind of base, used by architects in the Ionic, and sometimes in the Roman Doric order. It consists of an upper and lower torus or round moulding; a Scotia or hollow moulding; and two fillets or square mouldings between them. The whole of them together being in height one-third of the thickness of the column, and projecting on each side one-quarter the thickness of the column. This description of base is so great a favorite, that the columns of most modern edifices are built upon it.

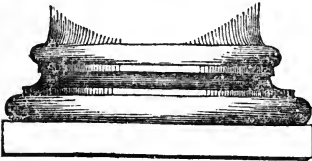

ATTIC. The upper story of a building, whatever be its shape, is in ordinary language an attic. In architecture, it implies that the story is of the same height all along, and with windows. If this part be decorated with pilasters, it is said to be of the attic order.

ATTITUDE. In painting and sculpture is the posture in which a figure should be placed to indicate the action intended to be represented.

ATTRACTION. A tendency which certain bodies have to approach and adhere to each other without apparent cause. There are several kinds of attraction, as of gravitation, cohesion, capillary, chemical, electrical, and magnetic.

ATTRACTION of Cohesion, is that power which causes the particles of bodies to unite into a solid mass. As small masses of lead melted together become a uniform single mass by this attraction.

ATTRACTION of Gravitation. The power which communicates weight; it tends to draw all bodies to the earth, and the earth itself to

the sun. Also is the probable cause of the roundness of the heavenly bodies, as it is of drops of water, globules of mercury, &c.

ATTRACTION, Chemical. The tendency of certain bodies to become so intimately blended with each other, as to lose their individual character; the nature of both bodies being changed, and a compound formed from them, different in its properties from either. Thus potass and oil, chemically united, form soap, which is a body without the greasiness of oil, or the causticity of the potass.

ATTRACTION, Capillary. The power that fluids have of rising above their level in fine tubes or pipes. It is by this attraction that water is sucked up in sugar, sponge, &c.

ATTRACTION, Electrical. The tendency which two bodies, when in different electrical states, have of coalescing, until by union or approach they have become in the same electrical condition.

ATTRACTION, Magnetic, is that seen when a loadstone or an artificial magnet takes up any particle of iron in its vicinity.

ATTWOOD'S MACHINE. An instrument for ascertaining experimentally the laws relative to falling bodies.

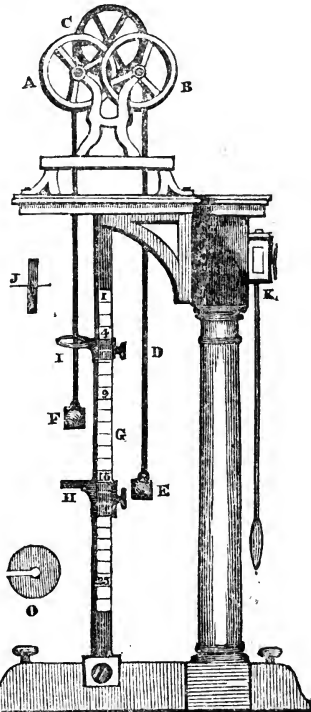

A B are two wheels, moving freely on their centres; these are called friction wheels, because they bear upon them one end of the

axis of the third wheel C. The other end of the axis of which is borne by two other wheels, similar in size and position to A and B. The wheel C has a groove on its end, in which the cord D passes. The cord D has an equal weight at each end E and F. From the upper stage of the machine proceeds to its foot a scale of equal parts G, for the purpose of measuring the velocity of descent. Upon the scale are two sliding stages H and I. H is solid ; I is a ring. L is a small bar of metal, (weighing a quarter of an ounce,) and K a clock, the pendulum of which beats seconds. O is a weight, (weighing a quarter of an ounce,) and of the same diameter as the weight P, though here drawn larger for the greater clearness. The weights E and F should be equal, so that they may stand at any point, without a tendency in either to descend ; and so adjusted, that a quarter of an ounce weight added to either, makes that side descend through one space of the scale in the first second of time. The following experiments will show the nature of the machine. Screw the stage H at No. 25 of the scale ; draw the weight F up to the top of the scale, and load it with the quarter of an ounce weight. Then let it fall exactly at the moment the pendulum is at one extremity of its beat. Mark the beats of the pendulum, and it will be found that at the end of the first second, the weight A will have passed over the first space ; at the end of the second beat, it will have arrived at No. 4 of the scale ; at the third second at No. 9 ; at the fourth second at No. 16 ; and at the termination of the fifth beat the weight will strike the stage H, or have passed through twenty-five spaces in five seconds, the space passed over being the square of the times. If instead of the weight O, the bar of metal J were used, it would be left on the ring at any part of the course previously determined upon, and the weight F proceed only in consequence of the velocity it had acquired ; this velocity or momentum may, in like manner, be measured.

ATTRIBUTES. Such symbols given to statues as indicate their character ; as a club is given to Hercules ; a trident to Neptune ; a thunder-bolt to Jupiter, &c.

AUGER. An instrument for boring large and deep holes, used by shipwrights, carpenters, &c. There are three varieties of augers. First, the old English auger, which has a cutting part at the end, and straight cutting sides. Second, the gimlet auger, which having a screw point, like a gimlet, forces itself into the wood, and suffers the sides to cut away the wood. Third, the American or screw auger, which has a point like a centre bit, and with a shank screw form, which allows the chips to escape, and assists in penetrating the wood to be bored.

AURATES. Combinations of auric acid and alkalies.

AURIC ACID. A term proposed by M. Pelletier for peroxyde of gold, because it combines with alkaline bases.

AURO-CHLORIDES. These are haloid salts, formed by the terchloride of gold, with metallic and other bases. Such are the aurichlorides of hydrogen, potassium, sodium, &c.

AURORA AUSTRALIS. The same phenomenon as the aurora borealis, but seen towards the south pole.

AURORA BOREALIS, OR NORTHERN LIGHTS. Flashes of electrical light, which appear at certain seasons and places, passing across the atmosphere, particularly from a point near the zenith towards the horizon. In hot countries they are rarely or never visible, and even in this country the aurora is seldom seen, but in the Shetland islands, where such lights are of frequent occurrence ; and where they are called "the merry dancers," and in places still more northward, as in Lapland, Norway, Labrador, and Spitzbergen, they occur so constantly, and so brilliantly, that they much enlighten and enliven the long nights of the polar winter.

AURORA FLASK. An electrical apparatus, contrived to show experimentally that the aurora borealis is an electrical phenomenon. There are two shapes given to the instrument, as represented below :

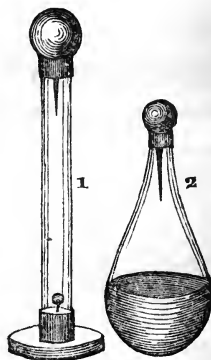

No. 1 is called the aurora tube ; it consists of a large cylindrical tube of glass, 2 feet or more long, with a brass cap, soldered on air-tightly at top, over the tube, the brass cap having a tapering pointed wire projecting about 2 inches into the glass ; on the foot is also a brass cap, which has a ball inside, and on the outside a screw which fits a condensing syringe, or air-pump, that the air may be partly exhausted from it, the syringe being afterwards removed, the screw unites the tube to a small wooden foot.

to enable the whole to stand upon a table. When the upper cap is held so as to take a spark from the conductor of an electrical machine, the spark will pass through the partly exhausted tube in quivering and uncertain flashes, resembling, in miniature, the aurora borealis. The other instrument, marked No. 2, is commonly called the small aurora flask. It is a glass vessel with a brass cap, exactly similar to the last, with a point inside, the glass being without a foot, but with a small perforation below, and is to be held in the hand when used. The use of the perforation is, that the fluid may pass away, otherwise it would become accumulated within, and a shock be, probably, the consequence. That it may pass away more readily, the lower part, where it is taken hold of, is covered with tin foil. As the perforation prevents a direct exhaustion of the air within, the flask should be put quite close to the fire for some minutes before use, the rarefaction of the air which will take place will be sufficient.

AURUM MUSIVUM, or MOSAICUM. Sulphuret of tin. This is said to be the substance made by the alchemists and imposed upon the credulous as gold, which it much resembles. It is a powder, used chiefly by the japanners of common tea boards, and by the Italians to give the appearance of bronze to their plaster images, after painting them.

AUTOGRAPH. An original piece of writing, whether it be a continued manuscript, or merely a signature.

AUTOMATIC. A word used by Dr. Ure to designate those processes which are carried on by machinery alone.

AUTOMATON. Any self-acting piece of machinery, but chiefly applied to such as are made to imitate living motions and sounds. Automatic spiders, mice, and singing birds, of Swiss manufacture, are not uncommon.

AUTUMNAL SIGNS OF THE ZODIAC. The signs libra, scorpio, and sagittarius, through which the sun passes during the autumn.

AVENAINE. A chemical principle, discovered by Hermbsträdt in oats.

AVERRUNCATOR. A pruning instrument, consisting of two blades, acting like scissors; one blade is fixed to a rod, and the instrument is worked by means of a string fixed to the other blade, and to be pulled by the operator.

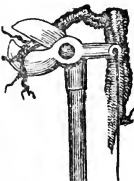

AVIARY. A building appropriated to the keeping of birds, sufficiently large to allow them scope for flight.

AVOIRDUPOIS. A series of weights, used for weighing coarse and heavy goods, such as the common metals; the necessaries of life; and numerous articles, used in manufactures,

such as cotton, silk, pitch, ivory, &c. &c. In this weight 16 drams, (dr.,) make an ounce, 16 ounces, (oz.,) a pound, 112 pounds, (lbs.,) 1 hundred weight, 20 hundred weights, (cwt.,) 1 ton. Besides numerous weights; used for particular goods, such as the clove, stone, wey, fother, &c., which are combinations of the regular proportions above indicated.

AXE. A heavy steeled instrument, employed in chopping, having its cutting edge parallel with the handle.

AXIOM. A self-evident truth, or one which neither admits of, nor requires a proof; for example, the whole of any thing is greater than a part of it.

AXIS IN PERITROCHIO. One of the mechanical powers, commonly called the wheel and axle. It is a modification of the lever, and its power is calculated in the same manner.

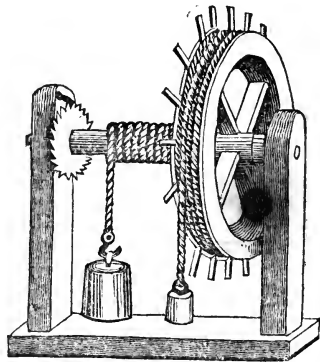

In the cut it is supposed to be turned round by the spokes upon its circumference, but sometimes, as in the instance of the crane and drawwell, a winch or handle is substituted. The power of such an apparatus is in proportion to the difference in diameter between the wheel which bears the smaller weight, and the axle which supports the other weight.

AXIS. In geometry, a straight line drawn from the apex of the figure to the centre of its base, as of a cone, a triangle, &c. In a cylinder it is the line which connects the centres of the ends. In a globe or circle it is any diameter. In an ellipse and hyperbola are two axes—the *transverse* axis is the diameter passing through the two foci; in the hyperbola it is, therefore, the shortest diameter, in the ellipse the longest; a diameter perpendicular to the centre of this is the *conjugate* axis. In astronomy an axis is an imaginary line, about which any of the heavenly bodies revolve. In mechanics it also indicates the line of motion, sometimes

imaginary and changeable; at others, fixed and certain. Axis is applied particularly to bars, round which wheels rotate. In magnetism it is the line which connects the poles of a magnet, without passing out of it.

AXIS of Oscillation. The shaft upon which any body vibrates.

AXIS of Refraction. (See *Refraction*.)

AXLE TREE. The centre upon which a carriage wheel turns. Axletrees are of two kinds; one in which the wheels and axle are fixed to each other, so as to turn together, the axle revolving in bearings attached to the carriage, by which the nave is less weakened, and the wheels have less play; for which reason such axles are now much used for railway carriages, though as both wheels move with equal speed, they are inconvenient for turning sharp angles. The second method is, that the axle is fixed to the carriage, and the wheels turn round upon it, independently of each other, by which means, in turning short, the inner wheel can remain stationary, and serve as a centre of motion to the carriage.

AZOTE. (See *Nitrogen*.)

AZOTIZED. Bodies containing much azote.

AZIMUTH. In astronomy, the position of either of the heavenly bodies, when above the horizon, with respect to an observer, reckoned in the points of the compass; thus, if a star be seen so many degrees east or west of the meridian of an observer, it would be said to have so many degrees of azimuth. If on the horizon it is called amplitude.

AZIMUTH, Magnetic. That position of a star, &c., indicated by the compass. It differs from the true azimuth, according to the variation of the compass at the place where the observation is made.

AZIMUTH CIRCLE. On a globe, a circle of degrees and minutes depicted on the wooden horizon of an artificial globe, whereby to ascertain the azimuth of any celestial body. A circle of the same description, name, and uses, is often attached to a quadrant and sextant.

AZIMUTH and AMPLITUDE CIRCLE. Dr. Brewster observes, "that this instrument is in itself, with the assistance of a good clock, a complete astronomical apparatus, as by it the astronomer is enabled to make all kinds of observations. He can ascertain right ascensions, transits, azimuths, and amplitudes; the latitude of his observatory; and the position of a star in any part of the heavens; it is also, when made portable, an excellent surveying instrument."

It consists of a strong, upright stem, F, which fits into, and moves freely, yet accurately, in a socket at the foot, bearing round with it, on the lower part, a brass horizontal circle G G, graduated into degrees, minutes,

and seconds. By this the telescope of the instrument is directed to any point of the heavens, and the point being ascertained, the degree marked off is read by the eye-glass at

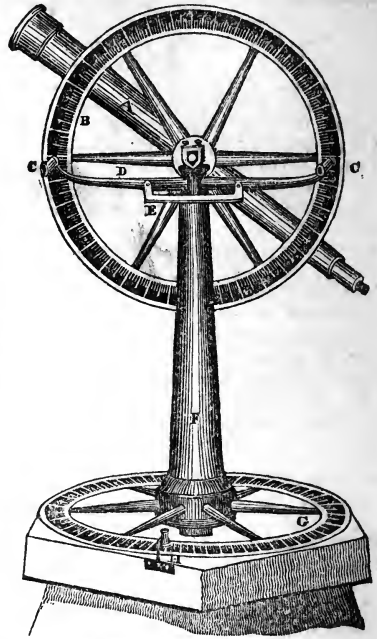

H. The upper part of the instrument consists of an astronomical telescope, marked A, which is fixed to a vertical circle B, graduated like the former in degrees, minutes, and seconds. This circle has a counterpart on the other side of the telescope, (though this last need not be graduated;) and there are six or more spokes, connecting each circle with a central axis, which is supported upon the upright stand. This being cut away in the middle, to allow the telescope freedom of motion in a vertical position. C C are two sights or reading glasses, to read off the degrees, which when the telescope is fixed is visible beneath them, or one of them. The reading glasses are connected with the arm D, which is fixed to F. E is a spirit level, to ensure accuracy of level, or horizontal position of the whole instrument, which it is evident must at all times be carefully attended to.

AZIMUTH COMPASS. Differs from the common magnetic compass, in having two sights attached to the upper rim, and in the whole instrument being so suspended as to be capable of being moved in every manner, both vertically round an axis, as well as horizontally; vertically, in order that the sights may be directed to any part of the horizon;

and horizontally, that it may accommodate itself to the motion of the ship in which it may be used; and also that the upper surface may remain parallel at all times with the horizon.

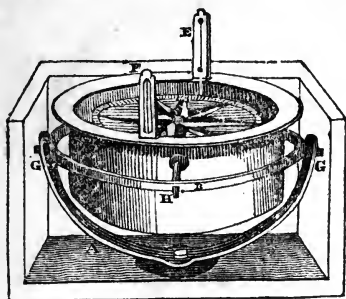

A is a brass semi-circular arm, which turns round on a pin below. B is a gimbal or ring of metal, supported upon the two pivots G G. At right angles to these pivots are two others, bearing the compass box, one of

which is seen at H. E and F are the two sights, through which the distant object, whose azimuth is to be taken, is viewed, A line from the slit of one of the sights E, continues down to the compass card, and which is graduated around the edge, indicating the number of degrees required. It is to be observed, that the compass card, from its being attached to the magnetic needle, keeps one certain position, N and S, (allowing for the variation,) while the box itself is moved round according to circumstances.

AZURE. The blue color of the sky; also, the peculiar blue pigment used by the ancient Egyptians, and which has preserved its brilliancy of tint for nearly 2000 years. Sir H. Davy says it may be imitated by keeping at a red heat for two hours, 15 parts of carbonate of soda, 20 of calcined powdered flints, and 3 of copper filings. Smalt is also called azure. (See *Smalt*.)

AZURE STONE. (See *Lapis Lazuli*.)

AZULMIC ACID. A new acid, found in the black matter deposited during the decomposition of hydrocyanic acid.



The second letter and first consonant in all languages, except the Ethiopic, where it is the ninth. It is a mute and a labial letter, that is, one pronounced by the aid of the lips. Its sound varies between the sounds of F, V, and P, with which letters it is

occasionally interchanged in translating from one language to another, and even sometimes in the same language; as, for example, in the Spanish. The form given to it now varies but little from that of long distant ages, as may be seen in the ancient Greek inscriptions. In music B is the name of the seventh note of the diatonic or ordinary scale; it has no sharp semitone. In contractions it stands for bachelor, Brutus, beatus, &c.

BABBAGE'S REVOLVING PLATE. This magnetic apparatus is the reverse of that invented by Arago; its object being to show that plates of sundry metals, besides iron, are affected by a magnet, when that magnet is put into a rapid rotation.

A is a powerful horse-shoe magnet, which is capable of motion around its centre, the poles being upwards as represented. B is a plate of copper, zinc, or other metal, about 14 inches over, balanced by a central spindle between the two arms of the upright support. When the magnet is made to rotate rapidly by means of the multiplying wheel C, it so affects the metallic plate above as to

render it magnetic also, as is seen by the rotation of the plate in the same direction as that of the magnet; the same being the case,

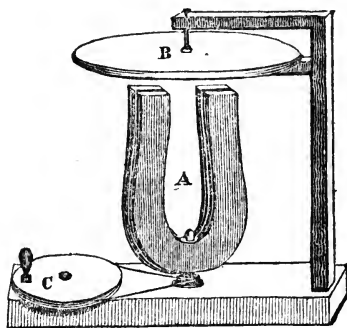

if either the magnet or the plate be shut up in a box, or a sheet of glass made to interpose between them. The effect, therefore, not being attributable to any impulse of the air.

BABINGTON'S GALVANIC BATTERY. An instrument originally invented by Dr. Babington, to supersede the *couronne des tasses*, and to which it is greatly superior, both in convenience, in power, and in economy.

It consists of a many-celled trough of earthenware, or as it was first made, of a wooden trough, with glass divisions across it, so as to form as many cells as there are pairs of plates of metal. The plates represented over the trough are of two metals,

zinc and copper, one placed alternately with the other ; each pair soldered together at the top, and so arranged, as to distance, that when placed in the trough, each cell shall have within it the zinc plate belonging to one pair, and the copper plate belonging to the next pair, and so on throughout the

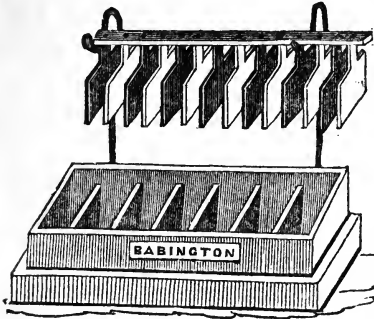

series. From the trough below arise two arms to support the plates when not wanted to be in action ; the plates being screwed on to a long slip of baked wood, that they may be all lifted and put down together, and that quickly.

BACCHUS. A pneumatic instrument, intended to show the effect of the elasticity of the air.

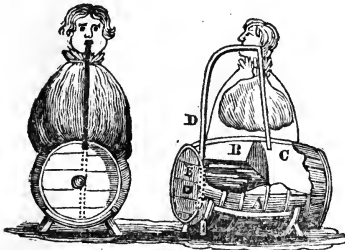

A figure is represented sitting across a cask A, in which there are two separate compartments, a portion of colored liquid being placed in one B. When the apparatus is under the exhausted receiver, the elastic force of the confined air causes the liquid to ascend a transparent glass tube, fitted into the mouth of the bacchanalian figure, and flowing still along the pipe, which is within the figure, fills the other part of the cask. When air is admitted into the receiver again, the liquid returns to the first compartment, as at first. To render the experiment still more striking, and indeed more illustrative, a bladder, with a small quantity of air in it, is fastened to the figure, and covered with the silk dress. The air in the bladder expands, and produces an

apparent increase of bulk in the figure, as occasioned by the excess of liquor drank.

BACHHOFFNER'S ELECTRO-MAGNETIC MACHINE. This instrument is intended to show, in a convenient manner, the effects of galvanism when passing along an extended conductor ; also, the effects of galvanic induction on a second extended conductor, in connection with the first. It unites in itself the effects of Callan's coil, (which see ;) and an apparatus for rapidly breaking and restoring contact, with other additions, as will be understood by the following figure and description :—

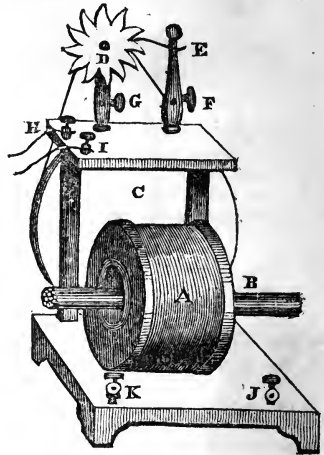

A is a double coil of wire. One coil of about 600 feet of No. 16 copper wire, covered with silk or cotton. This is inside, and is called the primary ; upon this is wound in the same direction, but quite unconnected with the first, a second coil of 2000 feet, (more or less,) of thinner copper wire, (No. 22,) also covered with silk or cotton. This is called the secondary coil. There is a hole in the middle of all, holding a bundle of iron wires tied together. The ends of the inner coil are soldered to the cups H, F, and I. The ends of the second coil to J. and K. The battery, which need not be more than a single jar, is to be connected with H and I. D is a toothed wheel, turned round by a small pulley at the back, connected with the multiplying wheel C. To use the machine, if a shock is required, G and H must be connected together ; if electro-chemical effects be wanted, connect together J and K, and place the substance to be decomposed between these cups. The fluid enters I, passes along the primary coil, and arrives at F, goes thence to E, (E F being a brass pillar ;) along the spring at E to the spurred wheel D. This being metal

conveys it to G. Whatever is placed between G and H receives the current. The wheel D only touches E when its teeth come against it; therefore in one rotation of the wheel there will be as many fresh contacts; also as many breaking of contacts as the wheel has teeth, consequently there will be felt as many shocks.

BACHHOFFNER'S VOLTAMETER is thus constructed:—A is a glass globe or bottle,

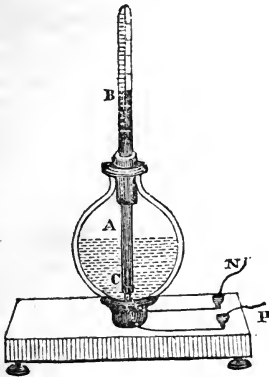

3 inches in diameter, having a perforated foot, into which two wires pass, and which are terminated by platina points, C, within the ball, and at the cups on the stand without. A has a cork to fit it, and a graduated glass tube passing through the cork upwards into the air, and downward into the globe. To use the instrument, fill B completely with water acidulated with acid, and partly fill A also with water, and put B in its place, as represented in the figure. Connect the battery with the cups, when the water will be decomposed, and the gases arising from the decomposition pass upwards into the graduated tube, and displacing the water, indicate the quantity produced by the battery, which is the object of a voltameter to ascertain. (See *Voltmeter*.)

BACK BOXES. The boxes on the top of the upper case used for printer's types, which are appropriated to small capitals in Roman letter; but which in imperfect founts, such as Italic, Old English, &c., are appropriated to irregular sorts.

BACK OF A COMPOSING STICK. The part on which the bottom of the type rests.

BACK. In a form of book-work those pieces of furniture are called backs, which are placed between the sides of a page, and the cross of the chase.

BACKS. The principal rafters of a roof.

BACKING. Preparing the back of a book by gluing, and otherwise strengthening it, so as to be ready to receive the cover.

BACHHOFFNER'S GALVANOMETER. A very sensitive instrument, of easy construction. A represents a coil of thin wire, covered with silk; its two ends being connected with the cups N and P. B is a double or astatic magnet, suspended on a single fibre of silk, hanging from a brass arm, C; the whole being covered with a glass receiver, and standing on a wooden foot. The suspended magnet indicates by its disturbance the intensity of the current passed along the coil.

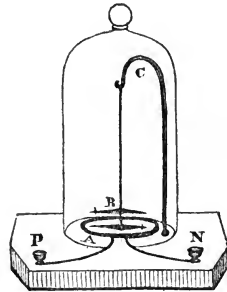

BACK STAFF. An instrument formerly used for taking the sun's altitude at sea, being so called because the back of the observer was turned towards the sun. This instrument is also called Davis's quadrant, from the inventor. It is now totally discarded from use.

BACKWATER, or SCOURING POWER. The stream of water employed to carry the filth from the mouth of a harbour, where a great quantity of water can be obtained at high tides, large reservoirs being filled at those times, the water is afterwards discharged on the bar at low water, when it carries every thing before it.

BADIGEON. A preparation for coloring houses. It is prepared with saw-dust, slaked lime, the powder of the stone with which the house is built, and a pound of alum, dissolved in a bucket of water. A little yellow ochre is sometimes added to it.

BADIGEON. A mixture of plaster and free stone, well sifted and ground together; used by statuaries to fill up the little holes, and repair the defects in stones of which their work is made. The same term is also used by joiners for a composition of saw dust and strong glue, with which holes and chasms in wood-work may be filled.

BAILEY. BAIL. BALE. The open space between one wall or line of fortification and another.

BAKING. The exposing any body to such a degree of heat as will dry and consolidate its parts without wasting them. Thus wood, pottery, and porcelain, are baked, as well as bread.

BALANCE. A lever, turning on a fulcrum or pivot, constructed for the weighing of bodies. The lever, or rod, is called the *beam*, each end of it from the pivot outwards is called an *arm*. When these arms are equal, it is the common balance or scales, which are two dishes, hung on what are called the points of suspension.

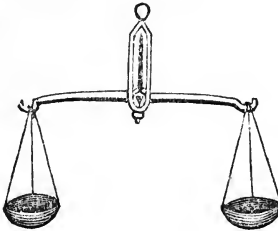

Balances are for various purposes, and are made upon different constructions. (See *Brady's, Bent Lever, Danish, Letter, Roman, Steelyard, Hydrostatic*, and other *Balances*.)

BALANCE DISCHARGER. An electrical instrument to regulate the discharging of Leyden jars and electrical batteries, according to the intensity of charge required.

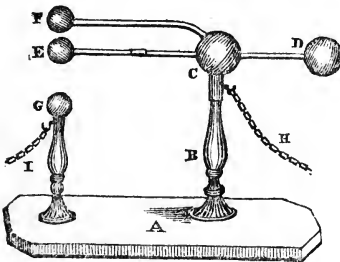

A is a foot-board, supporting two glass pillars, B and G. C is a brass ball and socket, fitting upon B, and by a hook attached to it holding the chain H. The ball C bears at top a brass arm and ball F, which are fixed immovably to it. Upon an axis, running through C, is supported the balance DE, also of metal: in order that this balance may play up and down, so that E shall be able to reach and fall upon G, a slip or long aperture is made on two opposite sides of C, wide enough for the wire to pass readily. There is also a chain attached to the socket of G, marked I; and a small moving weight, between C and E, to be slipped backwards or forwards, as required.

To understand the manner of action of this valuable discharger, it is to be remembered, that bodies when electrified similarly repel each other, in proportion to the degree of their electrization. Now connect H with the inner part of a battery, and I with the

outer, and see that the balance is loaded a little. The brass part of the balance connected with H will become charged, and when charged sufficiently to overcome the balance weight, the ball E will be repelled downwards, and fall to G; as this is connected with the outside of the battery, it will be discharged by the contact of G and E. In the above it is to be remarked, that while repulsion goes on between F and E, attraction will arise between E and G, therefore there is a double force to draw down E.

BALANCE ELECTROMETER, is of many forms and degrees of delicacy. The following is of easy construction, and adapted to show, in a lecture or otherwise, the general effects of electrical attraction and repulsion. It consists of a fine beam of metal or wood, suspended on a pivot affixed to a glass rod in the centre. It should be accurately balanced, and have at each end a pith ball, or piece of gilt paper. The glass rod must be very dry when the instrument is to be used; an excited stick of sealing wax or glass held towards one end will occasion it to move round its centre, and thus indicate plainly the excitement of the wax, or glass.

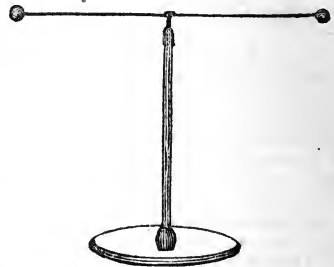

For a much more delicate balance electrometer, see *Coulomb* and *Tortion*.

BALANCE GATES. Flood gates, balanced upon a central pin, or axis, to each, as represented below; the inner side of each being rather larger than the outer side, the pressure of the water keeps them close, while a very small power is sufficient to turn them when required for the passage of the water.

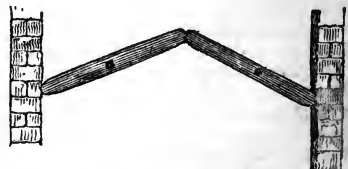

BALANCE THERMOMETER, of Mr. Kewley, is a contrivance for keeping up in apartments, green-houses, &c., an exact and even temperature; the instrument not

merely indicating the temperature, but also by the preponderance of one side over the other, closing or else opening a window of the apartment, or a damper of the fire-place. It may be described as follows:—

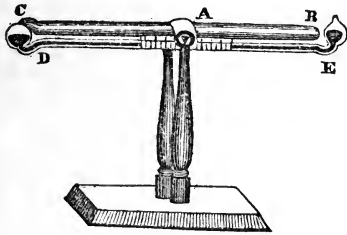

A is a tube or glass, filled with spirits of wine. It is closed at the end B, and opens into a ball at the end C. This ball has another tube connected with it, and opening into it underneath. The second tube D E runs parallel with the former, and terminates at E with a second ball, open to the air by a small orifice at top; the tube itself contains mercury. The whole arrangement of tubes is balanced on a knife-edge between the two upright supports. When a room in which it is placed becomes warmer, the spirit expands, and fills the ball C, driving the mercury forward to E; thereby making the end E heavier, until it sinks, and either pulls a string, or touches a lever, or an alarm. To regulate the degree of temperature at which it shall turn over, a scale is fixed on the side of the tubes, this being pushed backwards or forwards alters the first equilibrium, making either a greater or less force capable of affecting it.

BALANCE WHEEL OF A WATCH. That which answers the purpose of the pendulum to a clock, or which regulates the velocity of the motion. It is seen vibrating backwards and forwards when the watch is opened. The better kinds of watches and chronometers are furnished with a compensation balance. (See *Arnold*.)

BALAOON, or BALLOON. A large ball placed upon the top of a pier, pillar, or pediment, as a terminating ornament.



BALCONY. A projecting gallery in front of a window, supported by brackets, consoles, pillars, &c.

BALDWIN'S PHOSPHORUS. Ignited nitrate of lime. It may be made by melting

some nitrate of lime in a crucible, and keeping it in this state ten minutes. When cold and hard break the mass into small pieces, and inclose them in a phial well corked. They will, after exposure to the rays of the sun, emit a beautiful white light in the dark.

BALISTRARIA. A cruciform aperture in the wall of a fortress, through which cross-bowmen discharged their arrows; also a turret projecting from the wall of a building. In the latter sense better *Bartizan*, (which see.)

BALK. Any large piece of timber.

BALL. Any globular body, whether natural or artificial.

BALL AND SOCKET. A particular kind of joint, of which the one part is shaped like a ball, the other, or that in which the former works, is a hollow socket, of the same diameter. This fitting and pressing upon the surface of the ball allows it, together with whatever may be attached to it, freedom of motion in every direction, yet steady in all.



BALL COCK. A water cock, the plug of which has attached to it a lever, bearing a buoyant hollow copper ball at the lower extremity. Such an apparatus is self-acting, and is often attached to water butts, tanks, &c. It is represented as follows:—



When the water in the tank is drawn off, the ball sinks, and opens the cock, which admits the water. When this rises, the ball rises with it; in its new position closing the cock, and consequently stopping the stream of water; therefore the tank is always full, yet never runs over.

BALL FLOWER. An ornament common in the Gothic buildings of the decorated style of the fourteenth century. It consists of a ball, surrounded by three leaves.



BALL RACK. Two wooden pins, fastened into a feather-edged piece of wood, and attached either to a separate stand, or nailed against the wall of a printing office, intended to hold the balls used for inking the type.

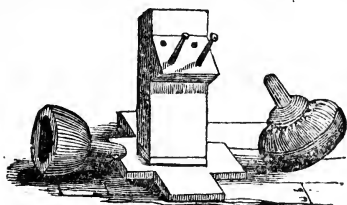

BALLS, PRINTER'S. A circular piece of pelt, leather, or canvas, covered with composition, stuffed with wool, and fastened to a handle. Its use is to cover with ink the type which is arranged ready for printing.

BALL STOCKS. Pieces of wood of the shape shown in the cut of *Ball Rack*; and turned out of maple, alder, or elm, intended to form the handle, and part of the body of a printer's ball.

BALL VALVE is represented in the margin. It is supposed to be seen withinside a cylinder. The ball is surrounded by four arms, fitted on the edge of a semi-circular cup, a hole being through the bottom of the cup. If this simple instrument be made the piston of a lift pump, at every down stroke the ball will be forced up by the water beneath, which will consequently rise round the edges, and fill the space above the ball. Upon the ascent of the pump rod, the ball will sink into the semi-circular opening of the sucker, which being made of a proper size to fit it, will consequently shut off the communication. A valve of this kind, being very easy to make, and not liable to clog, is very convenient for models and small pieces of machinery.

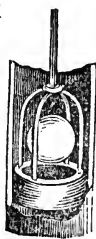

BALLAST WAGGON. The waggon employed in removing earth in excavations, &c. Each waggon holds from 2 to 3 cubic yards, when it is piled up.

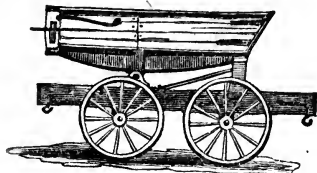

BALLAST LIGHTER. A large open barge employed in removing silt, sand, rubbish, &c., whether emptied into it from the shore, or slung up from the bottom of the stream, in

which latter case the lighter is attended by a ballast heaver.

BALLAST HEAVER. A large iron hoop, with a leathern bag sewed to it, to heave up dirt, sand, &c., from the bottom of a river. It is attached to a long handle, which in the operation of heaving is partly fastened to a rope, keeping thereby the bag to the ground, while a chain fastened to the iron hoop, and worked by a windlass, drags the machine along, and lifts it up for its contents to be discharged into the ballast lighter.

BALLASTING. Furnishing a ship with some heavy material to keep it upright and steady when unladen. In road-making it signifies the covering of roads generally; also the filling in of all holes and interstices between the rails of rail-roads, &c. In some parts of the country, the broken bricks, stones, and other rough material, spread over the foundation of buildings, for the brick or stone-work to rest upon, is called ballast or ballasting. This is, at other places, called bottoming.

BALLISTIC PENDULUM. An instrument for ascertaining the velocity of military projectiles. It consists of a heavy piece of wood, suspended from above, and with a needle and small arc attached to it, to indicate the result.

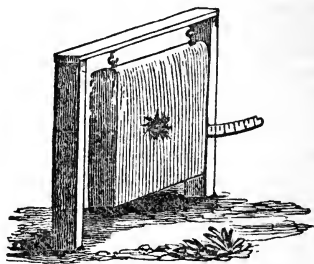

The above is a representation of it. When a cannon ball strikes the board, it occasions it to oscillate, and the utmost extent or angle of oscillation is indicated by the scale.

BALLOON. Any receiver of a globular form, more usually applied to an immense bag of silk, or canvas, made for the purpose of holding hydrogen gas, and of a sufficient size to be buoyant in the atmosphere, when filled with that light gas. Balloons for the purpose of navigating the air, at first consisted of such bags, expanded by smoke, and rarefied air, (see *Montgolfier*,) rising into it, in consequence of a fire being lighted beneath, therefore called fire balloons. At the present day gas balloons are the only kind employed, and it may be said, the English are the only people who venture to ascend in them. A balloon consists of the requisite pear-shaped or globular bag at top; a net-work of ropes over this; and a car of

wicker-work hanging from the ropes. It has also two clack valves on the upper part, one within the other. The small valve for the purpose of enabling the aeronaut to descend, and to let off superabundance of gas; and the other valve is with the object of emptying the balloon as early as possible after the car touches the ground, that it may not be dragged along after it has fallen.

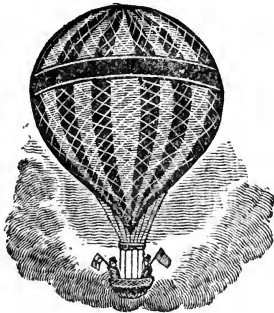

BALNEUM MARIÆ. A water bath. (See *Bath*.)

BALSAMS. Vegetable juices, either liquid or concrete, consisting of a substance of a resinous nature, combined often with benzoic acid. They are insoluble in water, but readily dissolve in alcohol and ether. The liquid balsams are copaiva, opobalsam, Peru, styrax, and tolu. The concrete are benzoin, dragon's blood, and storax.

BALSAM OF SULPHUR. A solution of sulphur in oil.

BALTEUM. A word used by Vitruvius to denote the bolsters or moulding on the sides of an Ionic capital.

BALUSTRADE. A range of ballusters, serving either for an elbow rest, as in porches; as a guard against accidents, as in balconies, staircases, &c., or to keep off persons from without, as around tombs, &c. It also often supports a coping, thereby forming a parapet.

BALUSTER. A little column, pilaster, or post, forming part of a balustrade. Balusters are of various forms, accordant with the style of architecture of the buildings to which they are appended. They are made of wood, metal, or stone.

BAMBOO. A cane-colored porcelain biscuit, invented by Mr. Wedgwood, and used for the manufacture of numerous utensils of domestic use.

BAND. In architecture, any flat member or moulding, that is broad and not very deep. Also the set of mouldings which encircle the centre of the pillar in early English buildings. A tablet or string course around a tower, &c.; as we say, a band of trefoils, or other ornaments.

BANDANNA. India handkerchiefs dyed in such a manner as to have round or square light colored spots upon a darker ground. All articles which are dyed in this manner are said to be bandanna dyed.

BANULET. Synonymous with annulet.

BANK. A deal table, on which printers keep the damp paper that they are about to print upon.

BANKER. A stone bench on which masons cut and square their work.

BAPTISTERY. That part of a church in which the baptismal font is situated.

BAR, in Architecture. A gate house, or barrier; thus Temple Bar, Holborn Bar, &c.

BAR. A piece of metal, or timber, placed horizontally, and running across from one part of any frame work to another. It also signifies an accumulation of sand or gravel at the mouth of a river, harbour, &c., formed by the tides.

BAR MAGNET. (See *Magnet*.)

BARBICAN. A watch tower; also a field work, a little beyond the walls of a town or castle.

BARES. Those parts of an image or statue which represents the bare flesh.

BARGE BOARD. BERGE BOARD. PARGE BOARD, or VERGE BOARD. A board fixed to the ends of the gables of timber houses, to hide the projecting timbers, and throw off the wet. They are often made highly ornamental.

BARILLA. A name given in commerce to the impure soda imported from Spain and the Levant. It is made by burning to ashes different sea plants, and is brought to us in hard porous masses, of a speckled brown color.

BARIUM. The metallic base of barytes. It is of a dark grey color, fusible at a red heat, turns to barytes when left exposed to the air, and when heated burns with a deep red light, is rapidly dissolved in water. It combines with oxygen in two proportions, forming 1st, barytes, or the protoxide of barium, and 2nd, the deutoxide of barium. It unites also with sulphur, phosphorus, chlorine, cyanogen, &c. Its salts are all white, and, except the sulphate, poisonous.

BARK. The covering of trees. The barks are in the arts a valuable class of bodies. The barks of the oak, willow, and other trees, contain much tannin, and are, therefore, useful in the art of tanning leather. Numerous barks have medicinal properties of no mean degree; others are employed by the dyers; or for various other purposes.

BARKER'S CENTRIFUGAL MILL. This valuable instrument derives its power from the force acquired from a stream of water rushing from two holes, so placed, near the ends of the arms of a moveable spindle as to throw the water on each side, and thereby

to occasion a counter action against the arms, propelling them, and whatever may be attached to them in a contrary direction.

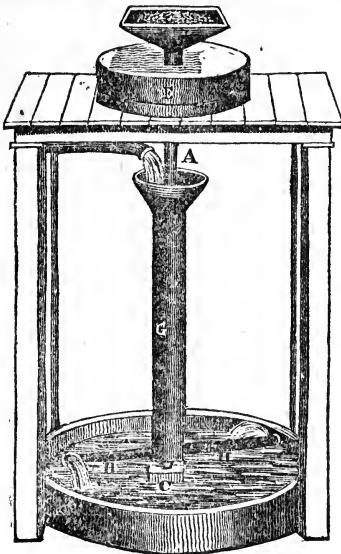

Suppose A in the above cut to represent a funnel connected with the hollow spindle G, this rests at the bottom on a pivot C, and bears a shaft above, which is connected with one of the mill-stones E. The hollow part of G is terminated by the two hollow arms B B, which arms have holes, as represented. A stream of water flowing into A will fall down into G, and fill the arms B B; at length rushing out of the holes. The air will offer such a resistance to the issuing of the water, that the arms, together with the other moveable parts, will revolve rapidly. Under the article *Centrifugal*, is the description of a mill, the contrary in effect to the above.

BARLOW'S COMPENSATION PLATE. An apparatus for counteracting the effects of the local attraction of the iron in a ship for the needle of the ship's compass, thereby enabling it to obey the terrestrial magnetic influence only. It consists merely of an iron wheel, placed in a certain position relative to a compass needle; and which position is found by actual experiment, by comparing the directive position of the ship's compass needle, with one at a little distance on shore; and holding, in the first instance, the compensation plate to the former, in such a manner as to bring it to the same point as the other. This being done by trial, the plate is then fixed in any convenient manner at that place. In the cut it is seen attached

to one of the legs of a tripod stand, the compass being on the top. Mr. Barlow recommends that the plate should be made of two very thin pieces of iron, with a card or thick paper between them. The plates are from 12 to 14 inches in diameter.

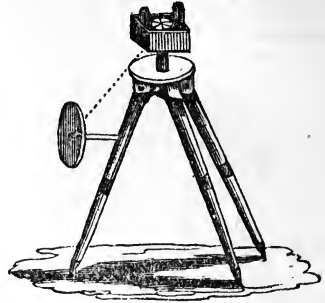

BARLOW'S ELECTRO-MAGNETIC GLOBE, is a globe of wood or pasteboard, 9 or 10 inches in diameter, supported upon two wooden uprights. The globe has a wire covered with silk or cotton, coiled completely over it from one pole round and round to the opposite pole. One end dips into the cup P, the other into the cup N. When the two poles or ions of a galvanic battery are connected with the wires in P and N, the fluid circulates around the globe, in consequence of which the globe becomes magnetic, though there is no iron attached to it; and a small, delicately-balanced magnet placed upon any part of it will indicate the polarity and dip, in exactly the same manner as the usual magnet does upon the earth itself.

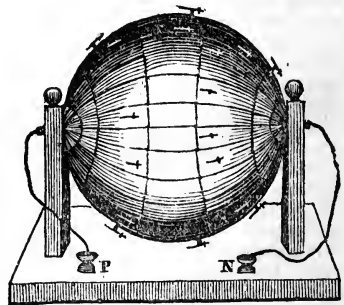

BARLOW'S SPUR WHEEL, is represented below. It is formed of a plate of very thin brass, cut with 8, 10, or 12 rays, amalgamated at their points, and supported upon two points of the cross arm, which is of such a height that the points of the teeth dip into a shallow trough, cut in the foot board. The cross arm as well as the trough at bottom are accompanied with mercury cups.

To use the wheel, put a little mercury in the trough, so that the points of the wheel just dip into it, and connect the two cups with the two poles of a galvanic battery, and place a powerful horse-shoe magnet with one pole on each side of the spur wheel, in the same manner as was represented in Arago's oscillatory plate. Immediately the wheel will begin a rapid rotation upon its axis. Two spur wheels are sometimes supported upon the same frame. It must be noted that one point must leave the surface of the mercury, before the next touches it, or the wheel will not rotate. For a modification of this experiment see *Sturgeon*.

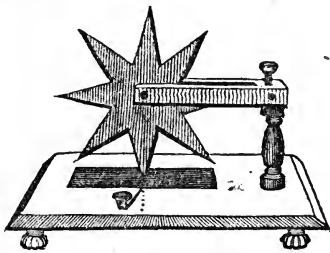

BARM, or YEAST, is a substance which separates, under the form of a froth, more or less viscid, from all the juices and infusions which experience the vinous fermentation, such as beer, wine, mead, cider, &c.

BAR POSTS, are those which are fastened into the ground, forming the sides of a field gate, and are morticed so as to admit of bars or horizontal pieces, which may be inserted easily, or taken out at pleasure.

BAROMETER. An instrument for ascertaining the weight of the atmosphere, and as this fluctuates according to the dryness of it, so the instrument fluctuates also, and this becomes indicative of corresponding changes in the weather. Also, as the weight of the atmosphere decreases from the level of the sea upwards, the barometer becomes a valuable instrument to measure heights. The construction of all barometers depends upon the principle, that the atmosphere presses with a weight of 15 lbs. on each square inch, and that in every direction; so that provided a tube be exhausted of air to prevent any counter pressure, and the end dipped in water, the weight of the atmosphere upon the water would press it into the tube, until it had attained such a height as to weigh 15 lbs. per inch surface; this column if of water would be 32 ft. long. As an instrument or weather glass, 32 ft. long is inconvenient, mercury is substituted; this by the same pressure stands at a height of from 28 to 32 inches, according to the state of the air. The barometer is, therefore,

an instrument formed of a tube of glass more than 32 inches long, closed at the upper end and open at the lower; then filled with mercury; and then inverted into a cup of mercury, which is exposed to the influence of the external air; the mercury will then stand at a certain height at the upper end of the tube, where a scale being placed, the pressure, and consequently the dryness or moisture of the atmosphere may be seen by inspection.

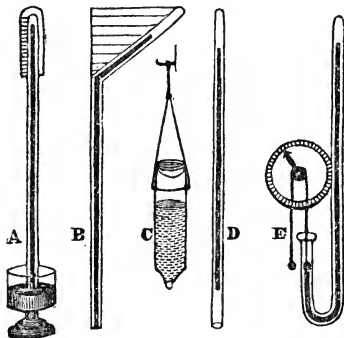

Such is the *common* barometer, figured A. The wheel barometer agrees in principle, but differs in arrangement; the glass tube is turned round at the end, so that the mercury occupies both legs; as it descends in one, it rises in the other, and *vice versa*, so that a little glass weight, with a string to it, passing over a pulley, and that pulley moving a hand, indicates with great precision the least change. E. The tube of a barometer should be at least a quarter of an inch bore.

The *diagonal* barometer has the upper part inclined at an angle of about 45° with the vertical portion, that the divisions may be more readily seen. B.

The *pendant* barometer is an instrument pretty rather than useful; it is now usually made of a small mouthed phial, nearly filled with water, and suspended from a ceiling, with the open mouth downwards; when the convex or concave lower surface is thought to prognosticate changes of the weather. C. The original instrument, which was invented by Amontons, was a slightly conical glass tube, 4 or 5 ft. long, closed at the top, and containing about 30 inches of mercury; according to the position in the tube which this occupied, so was the weight of the air ascertained. D. (See *Marine Barometer, Manometer, Boyle's Statical Balance, Portable Barometer, Sympesometer, and Mountain Barometer.*)

BAROMETRIC SCALE. The scale attached to a barometer. It extends from 28 inches to 31 inches, each inch being divided into

tenths and hundredths, by means of a moveable hand or slide.

BAROMETRICAL THERMOMETER. An instrument invented by the Rev. F. Wollaston, to ascertain heights, by the degree at which water boils at those places, such degree being accordant to atmospheric pressure, and consequently, the altitude above the level of the sea.

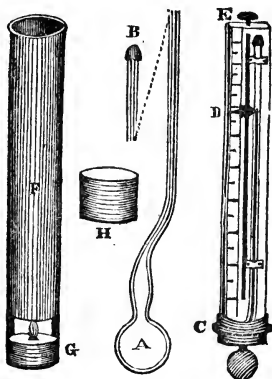

E D C is the instrument ready for use ; it has a scale $4\frac{1}{2}$ inches long, divided into 100 parts. The scale and thermometer tube are fastened to a double screw of metal C. D is the index which is moved up and down by the tangent screw E. A is an enlarged view of the thermometer tube. It has a large bulb, (1 inch) at bottom ; its tube is bent and widened out near the bulb, and at the top, instead of being closed in the usual manner, is sealed with a glass cap B. H is a cap to screw on to C, and defend the bulb when the instrument is not in use ; at which time the tube F also is put over the instrument, and fastened to the other screw belonging to C. Under F is seen a lamp which also fits into the case when not wanted. When the height of a place is to be ascertained, fill F with water and make it boil ; when boiling, immerse the bulb of the thermometer into it, from the degree of boiling may be ascertained the altitude of the place.

BAROMETER, Syphon. (See *Mercurial Guage.*)

BAROSCOPE. (See *Barometer.*)

BARREL. A cask holding from 32 to 36 gallons ; generally any middle-sized cask, whether for liquid or dry goods.

BARREL DRAIN. One constructed in the form of a hollow cylinder.

BARREL OF A DRUM WHEEL. The cylindrical part round which the rope is rolled.

BARREL OF A PUMP. The cylinder or hollow part in which the piston works.

BARTIZAN. A small projecting turret, capable of holding only one or two archers.



BARTON'S IRIS ORNAMENTS. Steel buttons, buckles, and other similar articles are so called when they have exceedingly fine and numerous lines or channels cut upon them, because such lines on these occasions what is called a play of light ; or, in more scientific language, they polarize the light which falls upon them, so that it is reflected in the most vivid and varying colors, exactly as we see in the reflection of light from the diamond ; and in an inferior degree from the surface of mother of pearl ; buttons thus prepared appear by candle-light of the most vivid and ever-changing brilliancy. Such ornaments were first made by Mr. Barton, of the Mint.

BARYA. Synonymous with barytes.

BARYTES. An alkaline earthy substance, composed of barium and oxygen : it readily combines with most of the acids. Its sulphate and carbonate are very abundant as minerals in many parts of England, and known on account of their weight by the name of "ponderous spar," though this term applies properly to the former only. It is scarcely used in the arts, is insoluble in water, and in alcohol.

BASALT. A ponderous, massive, black mineral, occurring mostly in immense columnar concretions, of which the celebrated Giant's Causeway, in Ireland, and Fingal's Cave, in the Isle of Staffa, are remarkable examples.

BASALTES. A black kind of earthenware, formed of basalt ground, mixed with a little borax, or soda, moulded and baked. Its use is well known in black tea pots, milk jugs, &c. It is very hard and durable, resists acids ; is capable of taking a high polish ; and will bear, without injury, a great degree of heat.

BASE. A rest or support ; particularly applied to the bottom of columns and pedestals. In geometry, the lowest part of a figure ; or that upon which it is supposed to stand.

BASE COURT. The back court yard of a castle, in which the out-houses were situated.

BASEMENT. The lower story of a building. In ordinary houses it is not called so, unless partly below the surface of the ground. In public buildings it supports the main order of architecture.

BASE LINE. In perspective, the common section of a picture, and the geometrical plane.

BASE LINES. The main lines of a survey upon which the correctness of the whole depends. In the following cut A B is the base line.

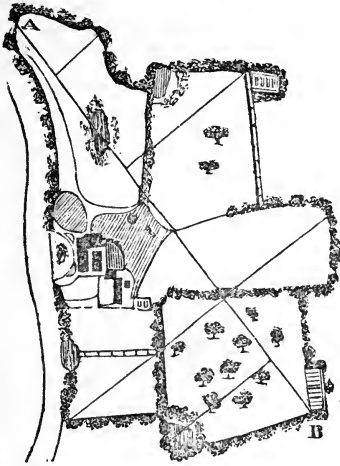

BASE MOULDINGS. Mouldings around the base of a building. The classical Greek buildings were without base mouldings, except as to the bases of the columns, and even these are only found in the more decorative orders. (See *Attic Base*.) The Romans adopted the column base of the Greeks, adding the following very simple base for the Tuscan order.

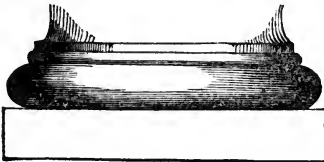

Gothic buildings are usually enriched with many ornaments around the basement story. Of the style of these the annexed cut will convey a correct idea.

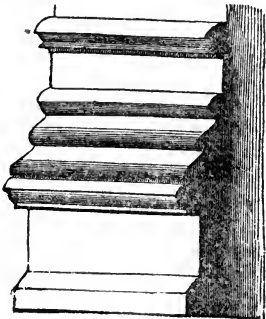

BASES. In chemistry, a term applied to all the metals, alkalies, earths, and other bodies, which unite with acids, or with gases. Thus in sulphate of copper, the copper is said to be the base of the salt, from the supposition that the non-acid principle is that which gives diversity or distinctness of character to compounds. The term is now retained from its convenience, rather than the truth of the above opinion.

BASIL. The angle at which a tool is ground, in order that it may cut readily.

BASIL LEATHER. Tanned sheep skin.

BASILICA. A public hall among the Romans.

BASSO RELIEF. Sculptured work, projecting less than half its proportions beyond the surface. (See *Alto Relief* and *Messo Relief*.)

BASSORINE. A constituent part of a species of gum which comes from Bassora. It is obtained by soaking gum Bassora in a great quantity of cold water, and in removing by a filter all the soluble parts. It is semi-transparent, swells in cold and boiling water, is difficult to pulverize, but very soluble in water slightly acidulated with nitric or muriatic acid.

BASTION. A rampart or bulwark projecting beyond the walls of a town.

BAT. Part of a brick.

BAT'S WING BURNER. A gas burner with a slit at top, instead of a round hole; the gas issuing from this burns in a flame, which is spread out like a fan, or a bird's wing.

BATH METAL. An alloy of $4\frac{1}{2}$ ounces of zinc and 1 lb. of brass.

BATH, in Chemistry, is a vessel filled either with hot sand, or with water, inclosing another vessel which contains a substance to be dried or heated; of a water bath the common glue pot is an example; a sand bath is of the same formation; it may be considered an iron pan full of sand: put on a fire it will become gradually and equally heated, and acting like a fire, heats whatever is put upon it, and that without danger to the glass vessels, or burning their contents unless the fire is very strongly urged. Baths have often been made of oil, melted lead, tin, &c., and steam has been advantageously employed to heat various bodies in the same way.

BATTENS. Boards from 2 to 7 inches wide, used for flooring, doors, &c. A door is called a battened door when made of a board of such a size as to fit the aperture, and this having styles, mullions, rails, &c. fixed on the exterior surface. Gates are often battened, being made of one range of battens placed diagonally, and another range of battens crossing them. Battens are also those narrow slips of board nailed upright to the bond timbers of a wall, in

order to nail the laths upon when the walls are plastered. Batten is also the moveable lath or bar of a loom, which serves to strike in or close, more or less, the threads of a woof.

BATTER. A term applied to walls built so as to lean inwards. In the dwarf walls of embankments, fortifications, &c., the walls generally batter.

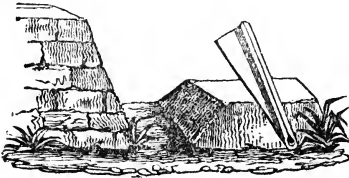

BATTER RULE. A plumb line, so contrived that while the plummet hangs perpendicularly, the building to which it is applied may be constructed sloping or battered. The difference between this, and the common plumb line is, that the edge of that instrument is parallel with the depending string; but of this the edge is made to differ from the parallelism, in proportion as the building is to taper.

BATTERY, Electrical. A collection of Leyden jars, so arranged that they may be all charged and discharged at once. (See *Leyden Jar*.)

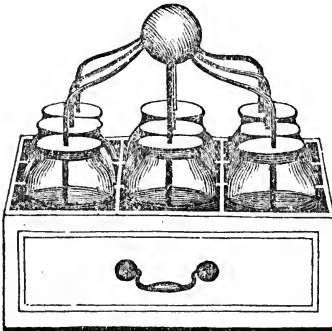

BATTERY, Voltaic or Galvanic. An arrangement of simple galvanic elements, so contrived as that they shall all contribute to produce a more powerful effect than they could separately. Galvanic batteries are of several kinds, and of different construction. In all of them the two metals of which they are formed, (see *Galvanic Circle*,) are opposed to each other in each combination. (See *Babington, Cruikshanks, Wollaston, Mullens, Daniel, De Luc, Coronne de Tasses, Volta, Grove, Smee, Faraday, Calorimeter, &c.*.)

BATTERY, Electro-magnetic, differs in no degree from the galvanic battery, except in being composed of few elements, scarcely more than one of each kind, when in action is made very energetic by stronger solutions than are necessary for ordinary galvanic purposes. (See *Sturgeon, Ampere, Marsh, &c.*.)

BATTLEMENT. An open, or interrupted parapet, terminating the walls of a building. Any wall with embrasures on the top, whether used for defence or not, is said to be embattled.

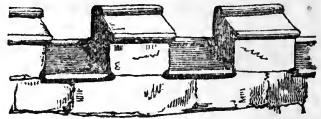

BAY. One of the compartments between the ribs of a groined roof; the main timbers of a common roof; the space between two buttresses of a wall; or between the mullions of a window. This last is also often called a *day or light*.

BAYEUX TAPESTRY. A celebrated piece of England by William the Conqueror, and long preserved in the Cathedral of Bayeux, in Normandy. It is supposed to have been worked by Matilda, the wife of William; or by the Empress Matilda, daughter of Henry I.

BAYONET. A piece of wood or metal, with two legs, to disengage and re-engage machinery. (See *Sliding Pulley*.)

BAY WINDOW. Bow WINDOW. A projecting window rising from the base upwards. A bay window is always straight-sided; a bow window part of a circle. An oriel window is a window of similar shape, but unconnected with the ground, being supported by brackets.

BEACON. A tower or pole erected, or fire lighted, as a signal of impending or present danger, such as the approach of an enemy.

BEAD. A small round moulding, sometimes plain, at others cut into divisions, like a necklace; in the latter case it is called *berried*, and when these ornaments do not correspond in size they are said to be blocked and berried. When made flush with the general surface it is a *quirk* bead; when projecting a *cock* bead. A number of beads united is called a *reeding*.

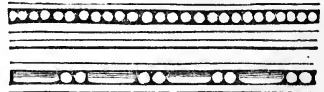

BEAD AND BUTT WORK. Framing in which the styles and panels are flush or even with each other; the panels having a bead on each side of them.

BEAD AND FLUSH WORK. In joinery, a piece of framed work, having a bead run upon every edge of the framing which adjoins to each edge of the inclosed panel.

BEAK HEAD. An architectural ornament, peculiar to the early Gothic style, resembling the head of a beast united to the beak of a bird.



BEALE LIGHT. This is to the common light of a lamp what a blast furnace is to an ordinary one. A common Argand burner is lighted, and through the centre of the flame is urged a powerful stream of air. The lamp is fed with any coarse material, such as tallow, tar, rosin, &c., and however impure either of these may be, yet the draught of air occasions it to burn with the most intense brilliancy, far more intense than the best materials will do under ordinary circumstances. It is the suggestion of Mr. Beale, engineer, of Greenwich.

BEAM. A strong piece of timber, used to support a floor, roof, &c. It has various especial names, according to its use. The lowest cross beam of a trussed roof is a *tie beam*; one extending between a pair of opposite rafters is a *straining beam* or *collar beam*; when it terminates the upper part of a truss it is a *camber beam*. (See *Roof* and *Brestsummer*.)

BEAM OF A BALANCE. The horizontal piece of iron from the ends of which the scales are suspended.

BEAM COMPASS. An instrument adapted for drawing very large circles. A long rod of wood, with a nail at each end, or at a requisite distance from each other, or a cord fastened at the required centre, is a common substitute by gardeners, carpenters, and other workmen. The better instrument is represented as follows:—

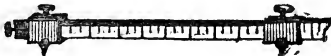

It is of a rod of wood, 2, 3, or more feet long, with two square ferrules slipped over it, each with a point below. One of these ferrules is fixed at the end of the beam; the other is shifted backwards or forwards, according to the size of the circle required.

BEAM FILLING. The masonry or brick-work which fills the interstices between joists or beams; also, the brick-work in the gable of a house has sometimes the same term applied to it

BEAN SHOT. Granulated copper.

BEARD OF A COMET. The light which it emits in the direction in which it moves, as distinguished from the tail or rays left behind it in its path.

BEARING. The position of one place from another, reckoned in points of the compass. Thus a place is said to bear NE. NW., &c., meaning that it lies from your present situation in those directions.

BEATER. An implement used by plasterers to mix together the mortar and hair required in their business.

BEATS. The strokes made by the pallets or fangs of a spindle in clock or watch movements.

BED. The upper and under surface of a stone or brick as it lies in a wall.

BED MOULD. That part of a cornice which is below the corona, between that and the frieze.

BED, of a Lathe. That part upon which the mandril of the lathe is fastened, and upon which the back poppit head and rest slide. It is in some lathes a triangular bar; in others, consists of two cheeks of wood or iron.

BEEBLE. A large wooden mallet, used for driving small piles; also the monkey or heavy weight which descends from a pile engine. (See *Pile Engine*.)

BEIGHTON'S HAND GEAR. An invention of Mr. Henry Beighton, in 1718, of certain contrivances to work the cocks and valves of the steam engine, and thus supersede the use of the boys or men previously employed for this purpose. It is therefore called hand gear, and with slight modifications is used to some engines at the present day.

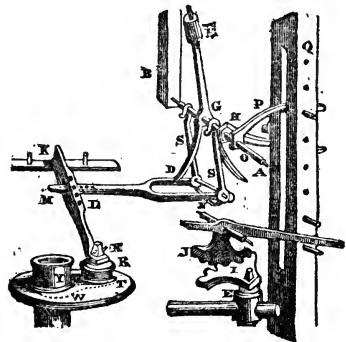

Between two perpendicular pieces of wood, (not to confuse the figure only one, B, is shown,) is a square iron axle A, which bears upon it the two hooks S S. The Y piece, as it is called, G, bearing the moveable weight F. Also the arms or spanners H and P. These two last, as well as the Y piece, being fixed.

N M is a forked frame, drawn backwards and forwards by the arms of the Y piece, and drawing with it the lever L. This rests at one end on K, and at the other is fastened to R, by a pin X. J is a lever and rack which moves I, and this moves the cold water injection pipe, while L regulates the admittance of steam to the cylinder. Q is the plug frame, which is attached to the working beam. In action Q rises and falls alternately; in rising it draws up P, and turning the axle A, brings D against the cross bar or stirrup N. This drags forward L, and shuts off the steam, and at the same time opens the injection pipe E. The descent of the plug frame reverses the effect, admitting steam, and closing the water pipe.

BEIGHTON'S STEAM ENGINE. This is a modification of the Newcomen engine, (see *Atmospheric*), differing from it principally in having attached to it an appendage to work the various valves, besides other minor improvements noticed below.

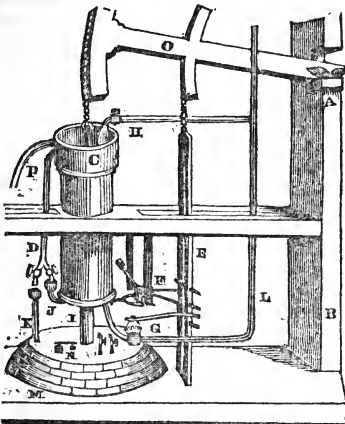

A B is the wall of the building or other support for the working beam, of which only one half is shown at O. C is the steam cylinder. H is a small pipe from the cistern above, to admit a little water above the piston to keep it tight. D is a pipe to admit a part of this water to supply the boiler by the pipe K. P is a pipe, leading to a distance, to convey away any surplus water there may be in C, and thus prevent its flowing over on the boiler. J is a small pipe, with a cup and valve at the end of it, to allow of the escape of any air there may be liberated in the cylinder. This air escapes with a slight noise at every descent of the piston, on account of which noise it is called the *snifting* valve. I is the pipe to admit the steam. J admits the injection water. E is the *plug frame* to move the valve. F the *hand gear*.

G the lever of the cold water cock. N the steel-yard safety valve, now for the first time introduced. M the boiler, cased in brick-work, upon which are two gauge pipes, as in Savory's engine. Another pipe, (accidentally omitted in the figure,) conveys away the injection water after it has been used.

BELL. A musical instrument, formed of one piece of metal. The parts of a bell are the body or *carell*, the *clapper* within, and the ear or *cannon* whereby it may be hung up. The edge of a church bell is generally in thickness one-fifteenth of the diameter of the bottom, and its height twelve times its thickness.

BELL. The body of a Corinthian or composite capital, supposing the foliage stripped off; called also the tambour or drum, and the corbel or basket.

BELL CRANK. A bent lever or arc, used chiefly in the hanging of bells, to allow the wire to accommodate itself to the alteration of motion requisite in turning corners, and otherwise changing its position.

BELL CRANK ENGINE. A suggestion made by Mr. Watt to do away with the beam of the steam engine, substituting for it a triangular frame or bell crank. The following shows this part of the engine; the cylinder, condenser, valves, &c., are as in other circumstances. The cut shows one side of the apparatus; the opposite side is exactly similar.

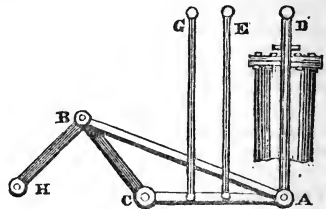

The point C is fixed. C A B is the bell crank. H is fastened to the working crank. The rod A D is attached to the piston rod. E works the air pump. G the hot-water pump, and it may be the cold water pump also. As A moves up and down, it carries B backwards and forwards, and this works the crank at H. Engines of this construction occupy but little room; the friction is, however, greater than in the beam engine.

BELL, Diving. (See *Diving Bell*.)

BELLS, Electrical. A small apparatus to show electrical attraction. The following is a view of one arrangement:—The hook and beam at top are of metal; two metallic chains support the two outer bells—the centre one and the clappers are suspended by silk strings. A chain connects the centre bell with the ground. When the whole is hung upon the charged prime conductor of an electrical

machine, the clappers will be attracted to the outer bells, and here receiving a charge will fly to the centre bell to deposit it, and thus flying backwards and forwards ring the bells. There are other forms of the instrument. (See *Chime*.)

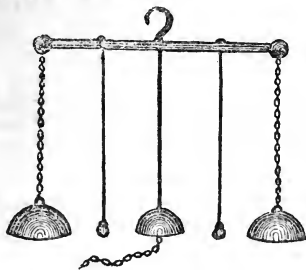

BELL GABLE. A small turret, placed occasionally at the west end of a church; intended to bear a small tinkling bell to be rung at the elevation of the host; not to be confounded with the bell tower, where the great bells were rung for assembly. Instead of a turret, a niche cut in the gable itself is sometimes used for the same purpose.

BELL METAL, is an alloy of 6 parts of copper and 2 parts tin.

BELL, Pneumatic. An apparatus to show that sound is not to be propagated in vacuo, and thereby to prove that sound is but the air in vibration. A small bell, according to one of the following forms, is placed under the receiver of an air pump, and the air being exhausted from the receiver, the bell although struck will yield no sound. The bells may be struck by a rod passing through the collar of the receiver, or by a small alarum attached to it. The first figure shows an alarum of this kind, where the string is supposed to go through the collar of the receiver at top.

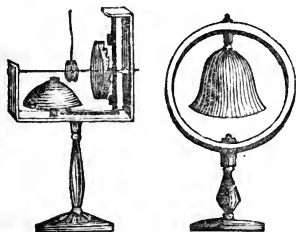

BELL ROOF. A roof, the cross section of which resembles a bell cut lengthwise; it is also called the *cima recta* roof, and is chiefly found in Elizabethan buildings.

BELLOWS. An instrument for producing a current of air, by a reciprocating, that is, an alternate up and down motion of one part or

flap of the machine, and used chiefly for urging a fire. If the stream of air is required to be intermittent, the single-valved bellows is sufficient; if continued, one with a double cavity, and an extra valve is requisite. They are both figured below.

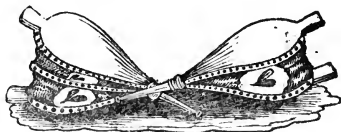

The single-valved or common bellows is formed of an upper and under board, with a skin of leather, nailed loosely between them. The upper board is entire; the lower furnished with a clack valve. The action is well understood. The double valve or forge bellows has, in addition to these parts, a board in the centre, also with a clack valve. So that in fact it is what the other would be, if an extra leather board and valve were fastened beneath it. The centre board should be a fixture—the nozzle connected with the upper cavity—the lower part to be moved when in use, and the upper board to be loaded or made of heavy materials. The action is this; bearing in mind that the central board is fixed, forcing down the lower board, its valve is opened, and its cavity filled with air; drawing it up again, closes its valve, and opens that in the centre. The upper cavity is now full of air, and being heavy the air rushes out of the nozzle in a continued stream. The form of either instrument is of no moment. (See *Blowing Machine*.)

BELLOWS, Hydrostatic. A philosophical instrument, of the following shape and appearance. It is intended to illustrate the hydrostatic paradox, and show that a small quantity of fluid force may be made to counteract a great mechanical resistance. The lower part consists of two round boards, a foot or more over, the larger the better, with loose leathers, fastened air-tight between them. This may be loaded with a considerable weight, and yet a person blowing down the tube, may, by that slight force, raise the weight, though the weight of the air be not more than an ounce, and the load upon the upper board a hundred weight; a person may thus lift himself up without danger. It may be used with still greater force by pouring water into the tube, when it will be seen that a pint of water, weighing one pound, may be made to overcome half a ton, if the leathers and boards be strong enough. The actual power is calculated by dividing the area of the bellows by the area of the pipe, and multiplying by the weight of fluid in the pipe, allowing in the first

place the water to displace any air there may be in the cavity of the bellows. (See *Bramah's Hydraulic Press*.)

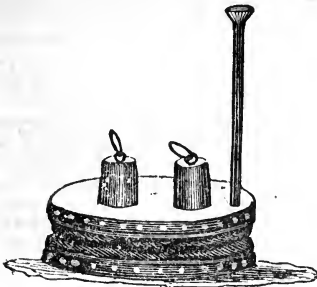

BELT. A line of stones or bricks projecting from a wall; also called a stone string; a string course and blocking course; though the latter term, (see *Blocking Course*,) has a somewhat more confined meaning.

BELTS. Zones or girdles surrounding the planet Jupiter, less lucid than the other parts of his body, and varying from time to time in width and relative distance from each other, but always parallel, and around the equatorial parts of the planet. Their nature and use has never been ascertained; some astronomers supposing them seas; others considering them to arise from certain alterations in the planet's atmosphere; something of a similar kind has been seen upon both Saturn and Mars.

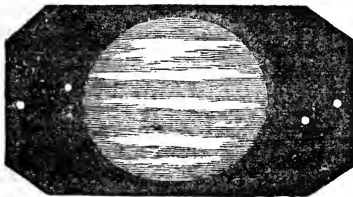

BELTED BOTTLE. A Leyden jar, the coatings of which are interrupted, or belted.

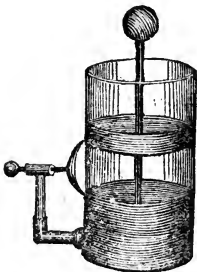

It has usually a medical electrometer, or something similar attached; in order to connect the belts when required, two wires should pass into the bottle, one touching the bottom to be drawn out occasionally; the other touching the inner belt. Drawing out the longer wire, the belt alone is charged; leaving it in, the whole bottle is affected; the requisite connection between the outer belts being made at the same time.

BELVEDERE. An observatory built above the roof, for the purpose of overlooking the surrounding country; also any small ornamented building on high ground in a garden, intended for the same purpose. One of the galleries, or open corridors, in the palace of the Vatican; is called the "belvedere," on account of the fine view it commands. From this gallery the celebrated statue of Apollo took its distinctive name.

BEN, OIL OF. Obtained from the ben nut by simple pressure. It is remarkable for its not growing rancid in keeping, or at least not for a number of years, and on this account it is used in extracting the aromatic principle of such odoriferous flowers as yield little or no essential oil in distillation; such as the hyacinth, jonquil, jasmine, mignonette, &c.

BENCH, OR BERM. A ledge, or narrow platform left on an embankment, in order to strengthen it.

BENCH HOOK. A moveable pin, or plug, passing through the top of a bench, for the purpose of holding the wood worked upon.

BENCH MARKS. In surveying, fixed points left on a line of survey for reference at a future time, consisting of cuts in trees, pegs driven into the ground, &c.

BENCH TABLE. The low stone bench, or seat, around the walls and pillars in many churches.

BENGAL STRIPES. Gingham, a sort of cotton cloth, woven with colored stripes.

BENGAL LIGHTS. A species of fire-work, producing a steady and very vivid blue-colored fire. Their composition is 28 oz. of sulphur, 12 oz. saltpetre, and 2½ oz. realgar. Let these be well pounded and mixed together, then sifted, and a portion put into a small paint pot. Cover this over with common paper, and apply a common lighted match to fire it. These are often called blue lights, and are much used as night signals by shipping.

BENNETT'S GOLD-LEAF ELECTROMETER. A most valuable instrument, for detecting minute electrical impulses. No. 1 shows the original form of the apparatus, as made by Mr. Bennett: it consists of a glass tube, such as a wide lamp glass, with a brass cap and foot. Within the glass, and attached to the brass cap, are hung two slips of gold leaf. As soon as any thing slightly electrified ap-

proaches the instrument, the gold leaves diverge, and if the impulse be strong enough, strike against two slips of tin-foil, which are pasted on the glass case. No. 2 is an improvement upon the above, suggested by Mr. Sausseur. The cap at the top is fitted with a glass tube in the centre of it, and the gold leaves are fastened on to the end of a wire, which passes through the glass tube, and which is terminated at top by a small table. In this form the insulation is more complete, and consequently the instrument more sensitive and certain.

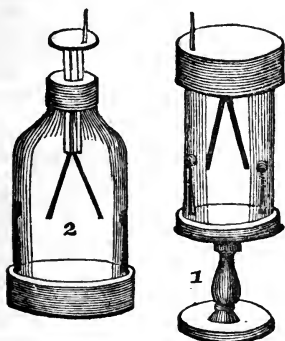

BENT LEVER. A lever of a bent or crooked form, of which the clawed hammer and the instrument for drawing teeth are examples. The laws by which the power is ascertained are precisely those of the common lever, (which see.)

BENT LEVER BALANCE. A weighing machine, represented as under:—

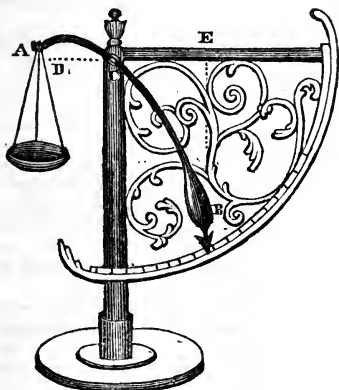

A B is a bent lever, turning on the pivot C, loaded at the end B, and having a scale suspended from A. When unloaded, the heavy

end of the lever hangs perpendicular, and in proportion to the weight placed within the scale, so will the end B rise towards the horizontal position, and indicate by the graduated arc what is the real weight of the body placed in A. The power is dependant upon the relative length of the levers, in reference also to their respective weights. Thus supposing each arm of the balance, that is, from A to C, and from C to the extremity at B, be of equal weight, the lever would remain in the position represented, because A C is equal to C E. The distance and the centre of gravity of each is in a horizontal direction from C, but in proportion as A is loaded, so will the ball B remove to a greater horizontal distance, while A will be scarcely removed at all farther from C.

BENZAMIDE. (See *Benzule*.)

BENZINE. A principle obtained by heating benzoic acid with hydrate of lime.

BENZOATES. Salts composed of benzoic acid and metalline or alkaline bases. Most of them are soluble in water.

BENZOINE. A crystalline substance, without taste or color, deposited from the oil of bitter almonds.

BENZOIC ACID, formerly called flowers of Benjamin, is made by subliming gum benzoin from a hot plate. It may also be obtained from many of the balsams, from amygdaline, and other matters. It is in the form of fine, white, circular crystals; soft like silk to the touch; very inflammable, with a sweetish, penetrating odour, for which reason it is much used in the making of pastiles and religious incense. It is soluble in oil, alcohol, and more sparingly in water: it unites and forms neutral salts with the alkalis. The alkaline earths and numerous of the metals forming benzoates.

BENZOIN GUM, or GUM BENJAMIN. A substance of a resinous nature, imported from the East Indies. It is of a speckled brown color, fragrant when burnt, somewhat brittle, and sweetish to the taste: it is soluble in alcohol, ether, sulphuric, acetic and nitric acids, and partially in ammonia.

BENZONE. A compound of carbon, hydrogen, and oxygen, procured by heating benzoic acid with lime.

BENZULE. A newly-discovered compound inflammable body, of which benzoic acid is an oxyde, and oil of bitter almonds, purified from hydrocyanic acid, is a hyduret. Benzule besides unites with chlorine, bromine, iodine, sulphur, and cyanogen. Chloride of benzule, with dry ammoniacal gas, treated with cold water, forms benzamide.

BERBERIN. A newly-discovered bitter principle, contained in the root of the barberry.

BERILLIUM. Synonymous with glucinum, (which sec.)

BERLIN BLUE. Synonymous with Prussian blue.

BERNOUILLE'S DIPPING NEEDLE, is a contrivance for regulating with greater precision than ordinary the degree of dip in a magnetized needle.



It consists of an ordinary bar of steel, with a circle of brass, ivory, or card, fixed concentric with its points of suspension. Upon one of these points is a small moveable arm, which, according as it is moved round, alters the centre of gravity. To make it, proceed thus:—Prepare the needle and circle, and balance them as accurately as possible. Then magnetize the needle, suspend it, and mark its dip; then take away its magnetism, and turn the moveable arm until it again dips to the same degree, as it did when magnetized. Afterwards magnetize it again, when being suspended a second time, it will show the real dip much more accurately than a common needle, or than it did at first.

BERRIES OF AVIGNON. The fruit of *rhamnus infectorius*, a plant cultivated in France for the sake of its berries, which are plucked before they are ripe. They are used to dye various shades of yellow, green, and olive.

BEVELLED WHEELS OF BEVELLED GEAR. Two wheels with bevelled edges, so that they work at certain angles to each other, and not in the same straight line.

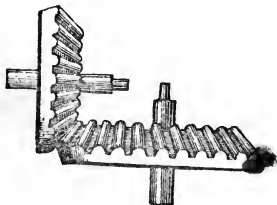

BEVIL. A portion of a flat surface, smoothly cut off, so as to form a regular

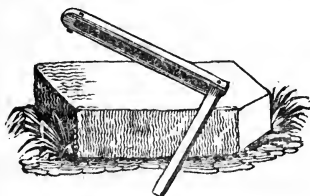

angle, either more or less than 90° . When the angle is exactly 45° , it is called a *mitre*. Also an instrument like a square, but having its sides moveable on a pin or joint, that it may be opened to any required width.

BEZOAR. This name, which is derived from a Persian word, implying an antidote to poison, was given to a concretion found in the stomach of an animal of the goat kind, which was once very highly valued for this imaginary character, and has thence been extended to the concretions found in all animals.

BI. BIN. BIS. TWICE. In chemistry signifies an extra proportion of that substance to which the bi is annexed, most commonly a double proportion; as, for example, the carbonate of ammonia contains one atom of ammonia to one atom of carbon. The bicarbonate contains two atoms of carbon to one of ammonia, and so on for other compounds.

BICE. A pale blue color, formed from smalt. When well ground, it forms one of the best of artist's colors. A green color, formed by mixing the blue with orpiment, also bears the same name; as also the blue carbonate of copper, as well as certain compositions of indigo and verditer, with chalk.

BIHYDROGURET OF CARBON. (See *Carburetted Hydrogen*.)

BIHYDROGURET OF PHOSPHORUS. (See *Phosphuretted Hydrogen*.)

BILE. A bitter liquid of a greenish or yellow color, common to most animals; the peculiar secretion of the liver. (See *Ox Gall*.)

BILECTION MOULDINGS. Those which surround the panels, and project before the face of a door or gate.

BILL, with letter founders, the same as fount with printers; that is, a certain quantity of type, proportioned in the number of each letter, stop, space, &c., as nearly as possible to the number in which each will be required in ordinary printing. (See *Fount*.)

BILLET, or BILLET MOULDING. An ornament common in Norman buildings, consisting of an imitation of wooden billets, alternately with vacant spaces.



BILLION. A million of millions according to English mathematicians, but according to the French only thousands of millions; in one case represented by 1,000000,000000; in the other by 1,000000.

BINARY NUMBER. A number consisting of two units, as 15, 73, &c.

BINOCULAR. An optical instrument is so called when made to be used with both eyes at once. Thus a pair of spectacles is a binocular instrument; a spy-glass is *monocu-*

lar, or to be used with one eye only. Opera glasses are now often made binocular, and so were formerly some microscopes and telescopes; but as they possessed but little advantage over the common instrument were doubly difficult to adjust, and besides doubly expensive, the use of them was never carried to any extent. In structure, instruments of this kind differ in no respect from the commoner sorts, except in being double.

BINDING SCREW. A term applied by opticians to denote the screws by which the wires of galvanic batteries, electro-magnetic apparatus, and other similar things are bound together, during the time of their action. As good metallic contact is necessary in electro-magnetic experiments, the extreme point of the upper screw, as well as the end of the wire to be inserted, should be made bright, when wanted for use in delicate experiments.



BINOMIAL. Any thing known by two names. In algebra a binomial quantity consists of two terms, connected by the signs, + plus, - minus, or = equal; thus, $a + b$, $a - b$, $a = b$, are all binomial. A *binomial curve* is one whose ordinate is expressed by a binomial quantity. A *binomial equation* is any equation of two terms, but more commonly applied to the higher order of equations. A *binomial surd* is used to denote a binomial, of which one or both of the branches are surd numbers; thus $a + \sqrt{b}$ is a binomial surd. The *binomial theorem* is a general algebraic formula, by which any power or root of any quantity is expanded into a series.

BINOXYDE. A combination of oxygen and a metal, in which the oxygen is in a double proportion, to what it is in the oxyde. If the oxygen be three-fold, it would form a tritoxide.

BIOT'S CONDENSING RIBBON. A is a glass cylinder or rod, an inch or more in

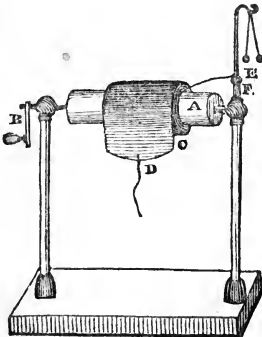

diameter, and 6 inches long; capable of being turned by the handle B; and when in use to be made perfectly dry. C is a coil of tin foil, cut so as to resemble a ribbon, 2 inches wide and 2 feet long, fastened to the cylinder at the inner end; attached to the outer edge or end is a silk string D. The ribbon has a wire above, connected with the pith balls at E, which are insulated from the stand by the glass rod F.

To use it, give the ribbon three or four sparks from the electrical machine, which will make the pith balls diverge. Then pull the string D, so as to unwind the ribbon. This extension of surface will make the balls collapse; winding up the ribbon again by the handle, the effect is again concentrated, and the balls diverge, as at first, making allowance for the casual dispersion of the fluid into the surrounding air.

BIOT'S SPHEROID. An experiment of M. Biot to show that the visible disturbance of the electric fluid resides only on the surface of bodies charged or excited. The apparatus necessary to prove this is a large metallic ball suspended on a silk cord, and furnished with two semi-circular cups, which fit over, and enclose it; the cups having glass handles. To use the instrument proceed thus:—Hang up the ball, cover it with the cups, electrify it thus covered up, by a few sparks from the machine; then take off the caps by the glass handles, hold either of them to a gold-leaf electrometer, when its leaves will show that the cups are charged. Holding the ball in like manner to the electrometer, it will undergo no change; that is, will show no signs of being affected, because it was beneath the surface of the cups at the electrizing of the whole.

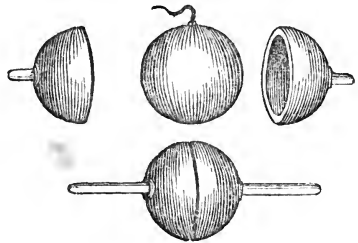

BIPARTIENT is a number that divides another into two equal parts; thus 2 is the bipartient of 4; 13 is the bipartient of 26, &c.

BIQUADRATE. A fourth power, or the square squared; thus 16 is the fourth power of 2. Twice 2 being 4, or the square; and 4 times that being 16, or the biquadrate.

BIQUADRATIC EQUATION, is an equation of the fourth degree, or in which the unknown

quantity rises to the fourth power: thus,
 $x^4 + a x^3 + b x^2 + c x + d = 10$.

is a biquadratic equation; x rising to the biquadrate. It is the highest order of equation which admits of a general solution; all beyond this being resolvable only in particular cases.

BIQUADRATIC ROOT, is the fourth root of any quantity; thus 2 is the biquadratic root of 16. It is the square root of the square root.

BIQUINTILE ASPECT OF THE PLANETS, is when they are distant from each other 144° , or twice the fifth part of 360° .

BIRD'S, (Dr.), CONTACT BREAKER. A is a bar of iron, 5 or 6 inches long, supported on an upright, near the centre of the foot-board, and capable of oscillating up and

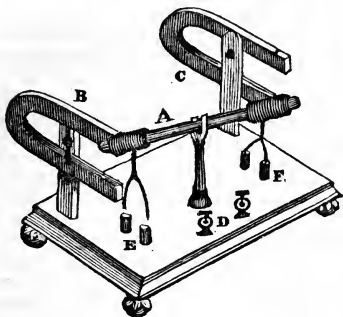

down about 2 inches: the iron bar has two covered copper wires coiled round it, one at each end; the two ends of the wires being twisted together, and terminating in a fork over the cups E and F. The two cups at E are connected with the two at F, by two wires beneath the stand. Behind the vibratory electro-magnet, or iron bar, are two horseshoe magnets B C, placed with their north poles uppermost, and at such a height that one end of the bar shall be at the north pole of one magnet, when the other end of it is at the south pole of the other magnet. D shows the situation of the binding screws to connect with the battery; one of the screws being united by a wire beneath to one of the cups at E, and the other screw to the remaining cup at E. The connection with the battery being made, A becomes a temporary magnet when either end dips in the mercury cups, and if the coils of wire be wound in a proper mode, the acquired poles of the temporary magnet will be repelled by the contrary poles of the permanent magnets, and the magnet itself will vibrate; the fork being lifted out of the cups, connection will be broken at that end, but formed at the opposite end. The poles of the temporary magnet are at the same time changed, and

repulsion again ensues; thus a vibratory motion, and with it breaking of the continuity of the circuit is established.

BIRD'S, (Dr.) ELECTRO-MAGNETIC MACHINE, consists of two upright bars of iron, with a primary and secondary coil of wire to each. (See *Bachhoffner's Machine*.) Over one magnet, or in any other way that is convenient, is fixed a brass beam F, having an iron ball at one end, and at the other end a stout copper wire F, forked below to dip into the cups at D. The binding screws A A are connected with the two ends of the primary coils, a break in the circuit being between the cups at D. The cups at D are connected with the binding screws at B B, which are connected with the ends of the secondary coils. The poles of a small galvanic battery being connected with A A, the fluid in the primary coils is disturbed, and makes the iron ball magnetic; the ball of the beam is attracted therefore to that coil which it hangs over, and consequently lifts the forked wire from out the cups at D, contact being thus broken with the battery, the bars of iron are no longer magnets. The ball of iron on the beam therefore rises again, and a second time the forked wire dips in the cups, and renews the first effect. In this manner, the rapid vibration of the beam produces a correspondent breaking and renewal of contact.

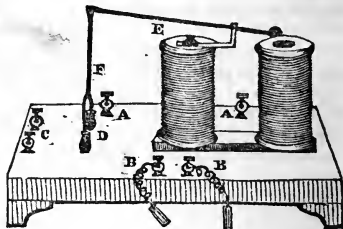

BIRD'S, (Dr.), INVERSOR. An instrument to reverse quickly the current from the galvanic battery. Its action is very simple, complete, and convenient.

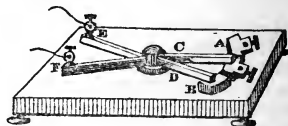

A B is an arc of solid brass, formed of three separate pieces, either distinct from each other, with a cavity between them; or else two pieces of ivory are inserted, that the surface at the top may be quite even. The two outer pieces of brass forming this

arc are connected together by a wire underneath the stand, but the centre pillar has no connection with the others. A and the centre piece have binding screws attached. C and D are two bars of brass, fixed to each other, so that when one is moved the other follows it, yet there is no metallic communication between them. There are binding screws at one end of each, while the other ends fit tightly upon the arc. The whole cross moves stiffly round the centre pin. The battery connection being made with E and F, the object to be galvanized placed between the binding screws of the arc, and the bars or cross, as represented in the cut, the positive pole being at E, the current would traverse D to B, thence underneath by the connecting wire to A, from A through the object to the middle piece, and from this by C to F. Slipping the cross aside so that C is moved to A, (other things as before,) the current would pass along D to the centre piece, thence through the object to A, and back by C to F, or to the opposite end of the battery. This is a most valuable instrument to the electrician.

BIRD LIME. A glutinous substance, made by boiling, fermenting, and well pounding the inner bark of the holly tree, or misseltoe berries. It is used chiefly for catching small birds.

BIRD'S BEAK. A peculiar Gothic architectural ornament, represented as follows. It occurs exclusively in buildings of the Norman or early English style.



BISCUIT. Unglazed porcelain.

BISECTION. The division of a quantity into two equal parts.

BISMUTH. A metal of a reddish white color, somewhat harder than lead, not malleable. It melts at 480° Fahr.; when partly cooled again in the crucible, if the still fluid portion of the metal be poured out, and the inner part of the crust left around the sides examined, the metal will be seen to have arranged itself in the most beautiful crystals. Bismuth is rapidly soluble in nitric acid, but not in muriatic nor sulphuric acids. United with other metals, bismuth mostly renders them more fusible. It is used in printers' types, in the composition of pewter, solders, &c.

BISSEXTILE. Leap year; a year consisting of 366 days, which occurs once every four years, except when that fourth year exactly completes the century. Such years are leap

years as will exactly divide by 4 without a remainder, except as before stated the centenary year; thus, 1792 and 1796 are leap years, but 1800 is not a leap year. It is called bissextile, because the sixth day of the calends of March was made double in such years among the Romans. This day answers to our 24th of February. We now add an extra day to February to signify the bissextile or leap year.

BISTRE or BISTER. A color made from the soot of dry wood, (of which beech is the best,) boiled half an hour in water, in the proportion of a gallon to 2 lbs. of soot. After it has settled, the water is poured from it, and when evaporated to dryness, and made into cakes with gum water, it makes good bistre. This color is much used by artists in water colors.

BITE. If the frisket of a printer's press is not sufficiently cut away, but covers some part of the form, so that it becomes printed upon, it is called a bite.

BITING-IN. The process of corroding copper and steel plates, which have been prepared by a ground laid over them, and the design traced through the ground with an etching needle. For biting-in copper plates, nitric acid diluted is employed; for steel plates many substances have been recommended. The following is to be preferred: 3 parts strong nitric acid, and 1 part of acetic acid; when this liquid is poured upon steel, faint tints will be produced in one minute, and the strongest required in four or five minutes. For the process, see *Etching*.

BITTS. Small tools used in boring wood or metal.

BITTERING, or, corruptly, BITTERN. A preparation sold to brewers and others for adulterating beer, and composed of cocculus indicus, liquorice, tobacco, quassia, and sulphate of iron.

BITTERN WATER. The water that remains after the crystallization of common salt in sea water, or the water of salt springs. It abounds in sulphate and muriate of magnesia, to which its bitter taste is owing.

BITUMEN. A fat unctuous matter, dug from the earth or skimmed off lakes; used by artists sometimes as a color, under the name of Jew's pitch. It is also valuable as a cement, forming a part of the asphaltic cement.

BLACK CHALK. A mineral of a blueish black color, a slaty texture, and which soils the fingers. It occurs in Caernarvonshire.

BLACK CHALK, for artists, is made in two ways: One is to saw into proper shape slips of charcoal, and afterwards boil them in hot wax. Second. Mix ivory black with soft fine clay, till of the color desired; mould it up with water of a proper shape, and set it aside to harden. This kind is much softer than the former.

BLACK'S, (Dr.) FURNACE. A very serviceable portable furnace; used for chemical operations, and which may be applied to numerous other purposes.

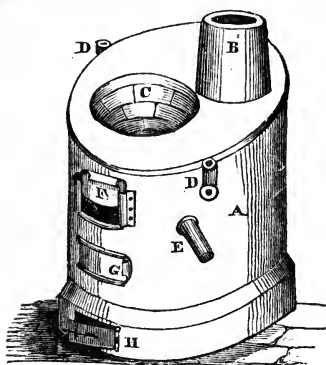

A is a vessel of sheet iron, lined around the part where the fire is with fire brick, that the heat may be the better retained. B is the chimney, which may be lengthened at pleasure. C is an aperture at the top, for the reception of an iron sand bath or water bath. D D are two sockets, for iron rods, which have a cross bar at top, to suspend various boilers by, that they may be over the fire. E is a porcelain tube or gun barrel, passing through the fire, for the production of certain gases. This may be removed when not wanted; when one hole being stopped up, the other will hold the nozzle of a pair of bellows. F is an aperture, with a sliding door for the reception of a muffle. G is a door, by which a crucible may be put in the fire; and H is the ash-pit. The fuel may be kept in the cavity under the chimney.

BLACK'S, (Dr.) BLOWPIPE. (See *Blow-pipe*.)

BLACK FLUX. A material used to assist in the melting of various metallic substances: it is made by mixing together equal parts of nitre and tartar, and deflagrating them together. The black substance which remains is a compound of charcoal and the carbonate of potass.

BLACKING. A compound either in the state of a liquid or a paste; used for putting a black gloss upon leather. The following is an approved receipt for a liquid blacking. Take of

Ivory black and treacle, each 12 oz.
Spermaceti oil 4 oz.
White wine vinegar 4 pints.

In the common blackings the oil of vitriol is used, but this acid is very injurious to the leather.

BLACK JACK. Miners give this name to blende, which is an oxyde of zinc.

BLACK LEAD. A mineral; used for making pencils for artists, crucibles for founders and chemists, as a powder to diminish friction, to put a polish upon stoves, and other iron work, &c. The best is brought from the mines of Cumberland; it occurs in large roundish masses, embedded in different kinds of rock. For its chemical properties, see *Plumbago*, by which name it is chemically known.

BLACK WADD. One of the ores of manganese.

BLADDER GLASS. In pneumatics, an instrument to show the pressure of the atmosphere. It is merely a glass vessel, open at both ends; upon the upper end is tied a piece of thin bladder. Upon putting this on the table of an air pump, and exhausting the air from beneath it, the bladder is pressed upon by the whole superincumbent weight of the atmosphere, and consequently the bladder is forced inwards, and if not too strong will burst with a loud report.

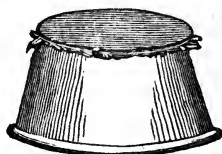

BLADDER AND WEIGHTS. A pneumatic instrument, to show the elasticity of atmospheric air. It is formed of a foot-board A, which has three stout wires for supporting a similar board at top.

B is another round piece of wood, with a cup-shaped cavity at top; and over this is C, which is a small bladder with a small quantity of air in it, so small a quantity that the bladder lies unseen in the cup B, when E, which is a similar cup, but with the hollow part downwards, is put over it. D represents three heavy leaden weights. The weights and cup E slide easily up and down between the wires. When this instrument is put under the receiver of an air pump, and the air exhausted from around it, the elasticity of the air within the bladder C will expand it so much, as to raise up the heavy weights above it. and thus show its rarefaction.



BLAIR'S, (Dr.) ACHROMATIC LENS. An improvement suggested by Dr. Blair, of Edinburgh, to correct the slight tinge of color apparent on the objects seen by even the best achromatic telescopes, called the secondary spectrum. His first idea was to have a concave achromatic lens, to refract

the green rays towards the axis; and a convex lens to refract them from the axis, thus to neutralize each other's effects, and propel the green rays of light along with the red and yellow, which on account of the greater refrangibility of the green rays were, under ordinary circumstances, separated, occasioning the secondary colors complained of.

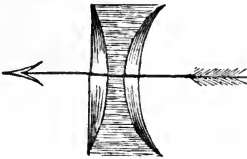

The above being a difficult and complex combination of lenses, Dr. Blair afterwards suggested the interposition of a fluid between two glass lenses, as follows, making the fluid a concave lens. The fluid he employed was muriatic acid, mixed with a metallic solution. In the spectrum formed by this fluid, the green were amongst the most refrangible rays, and when their dispersion was corrected by that of glass, there was produced an inverted secondary spectrum; that is, one in which the green was above, when it would have been below with a common medium. He therefore placed a concave lens of the above fluid between two glass lenses, as shown in the figure, and with such success that no trace of color is visible.

BLAKEY'S ENGINE. A slight modification of Savory's steam engine, for in Savory's engine the steam comes into immediate contact with the water to be driven out, consequently is much condensed. Blakey took out a patent in 1756 to prevent this, by interposing a stratum of oil or air between the water and the steam. The method of accomplishing this was by the following engine:—

The fire-place, chimney, &c., was as in ordinary engines. E is the boiler. D a pipe proceeding from it into the receiver, or air vessel I. This receiver is placed over another vessel V, of equal capacity, and joined to it by the pipe F. The receiver V is connected by the pipe Q with the well suction pipe, and the eduction pipe X. C is a funnel to supply the boiler with cold water. T the injection pipe, and cock L. P a cock to supply air to the receiver, or to permit its escape when its accumulation renders it necessary; this is also employed as a gauge cock. H is to let off superfluity of water from the receiver. G is a gauge cock on the boiler.

The operation of the engine is very simple. Steam is generated in E, which flowing through D disperses the air in I, driving it before it like a piston, through F into V, which pressing upon the water in V, forces it

through the pipe Q, the valve A, and up the eduction pipe. When all the water at V is expelled, the cock L is opened, and the water falling through the cullender, placed in the end of the pipe, condenses the steam in I, and falling through a second cullender S, also condenses the steam in V. A vacuum being produced in I, and part of V, the atmospheric pressure upon the water in the well at M, drives it up the pipe Q into V; when this is full, turning off the cock L, and turning on the steam D, the contrary action is produced, as in the first instance.

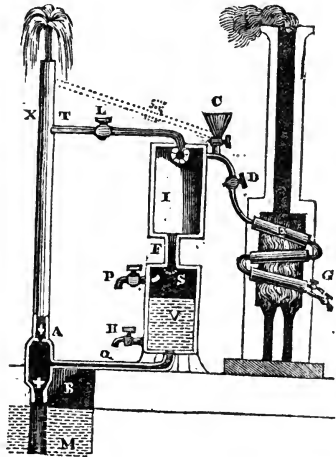

BLANCHED COPPER. An alloy of 8 ozs. of copper and $\frac{1}{2}$ an oz. of neutral arsenical salt, fused together under a flux, composed of calcined borax, charcoal dust, and fine powdered glass.

BLAST PIPE. A pipe employed in locomotive engines to convey the waste steam up the chimney, and to urge the fire by creating a quicker draught.

BLASTING. An operation resorted to in mines and quarries, for the purpose of detaching large masses of earth, stone, or metals. The operation is as follows:—A hole is bored in the stone, 1, 2, or 3 feet deep, according to circumstances, and $1\frac{1}{2}$ inches in diameter; a charge of gunpowder, made like a cartridge, and with a slow match to it, is then put in, and sand or clay put at the top of it, so as to fill the hole. The fusee or slow match is made to burn a certain time before igniting the powder, to allow the workmen to get out of danger.

BLAST FURNACE. An inclosed fire-place, the heat of which is augmented beyond that of an ordinary furnace, by a strong current of air driven into the fire by means of a forge bellows, or some other blowing machine.

The following is a blast furnace of a simple and approved construction.

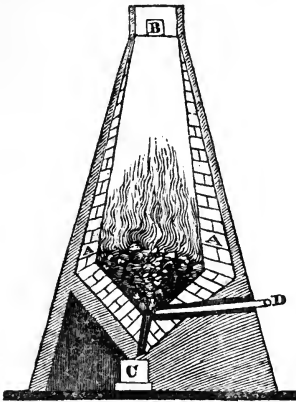

The outside is of common brick-work, lined with fire brick A A ; it is fed through the hole B. The fire at the bottom is urged by the blast from the pipe D. An opening is left at bottom for the escape of the melted metal into the receiver C, whence it may be made to run into moulds prepared for it. Blast furnaces are chiefly used for the smelting of iron and other refractory metals. A furnace of this kind is never allowed to cool, but fresh ore and fuel is continually poured in at the top, as may be found necessary.

BLEACHING. The chemical art by which the various articles, used for clothing and other purposes, are deprived of a dark color, and made to assume a whiteness not natural to them.

BLLENDE. An ore of zinc.

BLIND TOOLING. A term used by book-binders to signify marks made on the leather of bound books, by means of a tool made hot ; used in distinction to those books which are gilt on the edges, back, &c.

BLINDS. Screens, formed of various materials and fixed in window frames, either to exclude a too-strong light, or to screen the interior of an apartment from the observation of persons on the outside, without obstructing the view of those within.

BLOCK HOUSE. A building erected by besiegers for the investment of a castle.

BLOCKING COURSE. A course of plain stone work, placed above the cornice in the Grecian and Roman style of building ; also a course of stone or brick, with mouldings projecting beyond the wall, and forming a base to the whole.

BLOCK. A piece of wood, containing one or more sheaves, upon which a rope is run for lifting heavy weights. (See *Pulley*.)

BLOCK, as applied to railways, a foundation or support for the rails upon which the chairs are secured. Blocks are generally about 2 feet square, and placed in the following manner :—

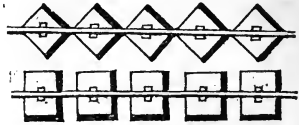

BLOCKINGS. Rough square pieces of wood glued on the joints at the under-side of stairs ; at the back of fascias ; show boards, &c., to strengthen the joints. The joints of wooden columns are always blocked.

BLOOM or BLOOMARY. A mass of iron after having undergone the first hammering. It requires several hammerings to render it malleable enough for smith's use.

BLOWING MACHINE. Any instrument for producing a blast of air, the common bellows for example ; though the term is mostly applied to those implements applied for the same purpose to blast furnaces, and similar extensive operations. The following cut is a very simple and effective machine applicable to domestic use :—

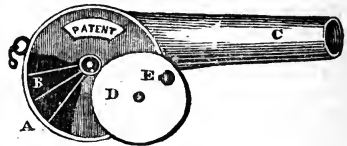

A is a flat drum of tin, with a hole at the back, and a tube C at the edge ; withinside is a wheel of tin, formed only of several arms B. This wheel fits with a pivot into a hole at the back, and has a projecting pivot in front. D is a moveable wooden wheel, bearing so tightly upon the front pivot of B, that when the wheel D is turned round, as it may be by a handle at E, the wheel B turns with it, and produces a constant draught of air, which issuing from the mouth of C may be urged against a fire, or as otherwise wanted.

The following instrument, while it occupies less room than the common forge bellows, is upon the same construction, and equally powerful. A is a handle to be moved up and down. B B two arcs, upon which are two chains which proceed downwards to the lower part of C. Pulling down the handle then lifts up C, and empties the air within it into D, through a valve which belongs to the centre board, as explained under the word *Bellows*. D has a weight upon it, which is always forcing the air through E to the fire.

The handle being let go, the weight F brings C down again, ready for a fresh supply, so that a constant stream of air is kept up.

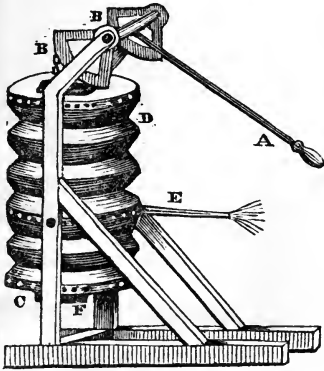

BLOW-PIPE. An instrument to produce a small and constant stream of wind, chiefly required to increase the heat of a small flame, as that of a lamp or candle. The simplest blow-pipes are used by blowing into them by the mouth, as the following:—

A is a tapering tube, used by jewellers and others in soldering and melting small portions of metal. B is for the same purpose; its particular form is that which was suggested and approved by Dr. Wollaston: it is made in two or three joints for the greater convenience of carriage. C has a bulb on the stem, for the purpose of retaining the moisture of the breath. It is called, from its inventor, Bergman's blow-pipe. D is an improvement upon this: it consumes the breath at the end, and has a moveable jet: it is called Peppys's blow-pipe. E is the form used by Dr. Black.

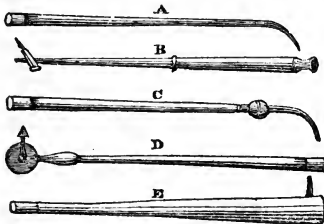

For the compound blow-pipes, (see *Glass-Blower's Table, Gurney, Tulley, &c. &c.*)

BLOWING VALVE. A small hole and valve, placed near the bottom of the condenser of Watts's engine, to liberate the air which may occupy this vessel before the engine is put to work; it is driven out as soon as the steam from the cylinder rushes in.

BLUBBER. The fat which invests the bodies of all large cetaceous fishes, serving to furnish train oil, which it does by boiling. A large whale will yield from 3 to 4 tons weight, or about 1000 gallons.

BLUE POWDER. (See *Powder Blue* and *Stone Blue.*)

BLUE. One of the three primary colors; mixed with red it makes a purple, with yellow a green. It is a cool color, and harmonizes well with most others. Its contrast or accidental color is orange. The principal blues used by the painter are ultra-marine, bice, Prussian blue, and indigo.

BLUNGING. The art of mixing or kneading clay for the potter's use.

BLUE DYE. (See *Indigo, Prussian Blue, Logwood, &c.*)

BLUE VITRIOL. Sulphate of copper.

BOARD. A piece of timber of an oblong form, of any length, generally more than 4 inches broad and less than 2 inches thick. When one edge is cut thicker than the other, such boards are called *feather-edged*; when broader than 9 inches they are called *planks*; if narrow they are *lattens*. As imported, that is, 2½ or 3 inches thick, they are called *deals*.

BOASTING. In sculpture or carving is the rough cutting of a stone to form the outline of a statue, or an ornament.

BOAZ'S STEAM ENGINE. An application of the steam engines of Savory and Papin, by which water can be raised without condensing the steam.

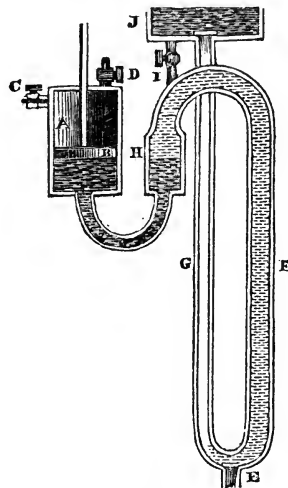

A is the steam cylinder, supplied by the pipe C. B is the floating piston, attached to a piston rod in A. D a waste steam cock. F a pipe, which generally contains hot water.

E a valve, opening from the well upwards. **G** the eduction pipe, conveying the water upwards to the reservoir **J**, through a valve at top. The air which accumulates in the receiver escapes through **I**. **H** is the exhausting vessel. The whole being filled with mercury and water, (as shown in the shading of the cut;) shut the cock **D**, and open **C**. The steam will press upon the piston, and drive the mercury into **H**, and this will drive before it the water above, and that throughout the whole length of **F** and **G** into the cistern **J**. When the piston is depressed to the bottom of **A**, a tappit or arm attached to it opens **D**, shuts **C**, and the mercury therefore, from its gravity, recovers its first position, and raises **B**, leaving a vacuum in **G**, which is filled up by the valve **E** opening, and admitting the water of the well, which is pressed into it by the external atmosphere.

BOB. A round ball; the lower termination of a pendulum is thus called, as is the ball at the end of a string, used in levels, &c. by workmen; called in that case a plumb-line bob.

BODY, OR SOLID, is any thing which has three dimensions; length, breadth, and thickness. Bodies are either soft, hard, or elastic; and either solid, fluid, or gaseous.

REGULAR BODIES, OR PLATONIC BODIES. In geometry are such as have all their sides, angles, and planes, similar and equal; of which there are only the five following:—

1. Tetrahedon, contained under 4 equilateral triangles.
2. Hexaedron, or cube, contained under 6 squares.
3. Octaedron, contained under 8 triangles.
4. Dodecaedron, contained under 12 pentagons.
5. Icosaedron, contained under 20 triangles.

BOILER. Any vessel in which a liquid is boiled, more especially if of a large size. The common household boilers are *kettles*, *saucépans*, &c.; that employed by the dyer, brewer, &c., is called a *copper*; that made use of by the sugar refiner is styled a *pan*; and that which distillers use is a *still*; while many articles used in the arts and in science, for analogous purposes, are known by the names of retort, alembic, boiler, digester, &c.

BOILER, Steam Engine. That part of the steam engine in which the steam is generated. Boilers are almost as varied in form as the mechanical part of the engines themselves. The following, which from its shape is called the waggon boiler, explains its general structure, and the various appendages usually attached to it.

A is the boiler itself, formed of plates of wrought iron, well secured together by bolts. (The side of that in the cut is

taken away to show the internal structure.) **B** is the pipe to convey the steam to the

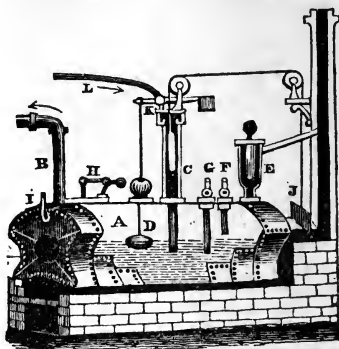

engine. **C** is a pipe to supply the boiler with water. When the supply of steam is too rapid, it forces the water up the bottom of the pipe **C**; this raises the weight within it, and lets fall the damper **J**, thereby decreasing the fire. **D** is the float, connected by a wire with a ball above, and that by a rod to the lever **K**. When the water in the boiler is too low, the float pulls the wire or rod, and turns the cock at **K**, letting more water in from the pipe **L**, which leads to **C**, and thence to the boiler. When there is enough admitted, the float rises, and turns off the cock **K**. **E** is a safety valve; when the steam is too high it raises the weight within the pipe, and escapes into the chimney. **F** and **G** are gauge pipes. **H** is the air valve, fixed to a large flat iron plate called the man-hole. **I** is the mercurial gauge. For the full description of these various parts, see their respective names, *Air Valve*, *Float*, *Gauge Pipes*, &c. For other boilers, see *Steam Engine*, &c.

BOILING POINT. That degree of heat at which a liquid boils. The boiling points of some common liquids are as follows, supposing them to be in the usual state of the air, and not in a condensed or rarefied atmosphere.

Ether ..	100° Fahr.	Water ..	212° Fahr.
Milk	„	Oil of Tur-	
Sulphur..	570 „	pentine	316 „
Mercury	656 „	Linseed	
Alcohol ..	173.5 „	Oil... 640 „	

BOLETATES. Salts formed of the boletic acid, and various bases.

BOLETIC ACID. An acid discovered by M. Braconnot in the juice of the boletus pseudo-ignearius.

BOLOGNA PHIALS, OR PROOFS, are small round bottles of unannealed glass, which fly to pieces directly anything angular is dropped into them.

BOLOGNIAN PHOSPHORUS. (See *Bolognian Stone*.)

BOLOGNIAN STONE. The ponderous spar or sulphate of barytes; remarkable for its making the Bolognian phosphorus, which is thus prepared:—Let the stone be first made red hot, then finely powdered, and made into a paste with gum water. Cut this into small pieces, and expose them to the heat of a wind furnace, by placing them loose among some powdered charcoal; when afterwards exposed for a few minutes to the sun's light, the pieces will become extremely luminous—giving light enough in the dark to read by.

BOLSTER. That part of a knife blade which joins and abuts upon the end of the handle. In architecture, the rolls forming the ends or sides of the Ionic capital are called bolsters.

BOLTING MACHINE. That part of the machinery of a flour mill by which the flour is separated from the chaff.

BOLTON'S ENGINE. (See *Watt*.)

BOMBIC. An acid discovered by M. Chausier in the silk-worm. It is of no known use.

BOND. A method of laying bricks or stones, so that the joints shall be as far distant from each other as possible, that the whole may be firmly knit together. No. 1 is called English bond. No. 2, Flemish bond.

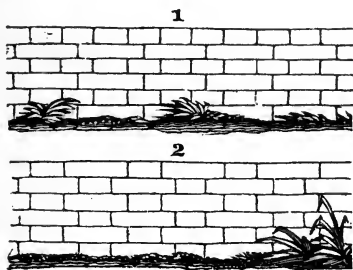

BONDERS. *Bond Stones, Binding Stones, Through Stones, Perpent Stones,* are used where rough stone walls are bound with cut stone, and are inserted at intervals, for the purpose of binding the facing to the backing, or rough stone wall behind it.

BOND TIMBER. Beams of timber put lengthways in a wall to bind the brick-work together, and distribute the pressure of the superincumbent weight more equally.

BONE PHOSPHATE. Sub-phosphate of lime.

BONE, TO. An expression used by artizans to signify looking down a flat surface, in order to see if it is straight.

BONNET. A hole formed in iron pipes, and furnished with a sliding lid for the purpose of clearing out the inside when requisite.

BOOKBINDING. The art of sewing the sheets of a book together, and furnishing them with a cover. (See *Cutting Press, Sewing Board, Plough, &c.*)

BOOMS. Pieces of timber left to float in front of coffer dams, to keep off the shocks of vessels. They are usually secured to the piles by chains, and rise and fall with the tide. Such beams or booms are sometimes thrown across the mouth of harbours for temporary purposes of defence or protection.

BORACIC ACID. *Sedative Salt.* The only known combination of borax and oxygen. It is obtained by dissolving borax in hot water, and afterwards adding half its weight of sulphuric acid. As the solution cools, white scaly crystals of boracic acid appear, which to be rendered pure must be melted, and made red hot. The acid will then be found fused into a white transparent glass. Boracic acid unites with the alkalis, earths, and many of the metals. It communicates a green color to the flame of spirits of wine, or when ignited with gunpowder, for which purpose it is used in the theatrical blue fires, and in fire-works.

BORATES. Combinations of boracic acid with alkaline, earthy and metallic bases. The borate of soda, or *borax*, is the only one extensively used in the arts.

BORAX. BORATE OF SODA, is imported from India in an impure state, under the name of *tincal*, *pounxa*, or *chrysocolla*. It crystallizes in irregular hexagonal prisms, slightly efflorescent. Its taste is alkaline and styptic; soluble in 12 parts of cold and 2 parts of boiling water. When heated it loses its water of crystallization, and becomes a porous powdery mass, called *Calcined Borax*. It is decomposed by most of the acids; is valuable as a blow-pipe flux, and instead of rosin in soldering. Clothing dipped in its solution is rendered to a certain extent incombustible: it is the principal source whence boracic acid is obtained.

BORAXATED TARTAR. If 2 parts by weight of borax be added to 5 of crystals of tartar, (bitartrate of potass,) the tartar becomes much more soluble than before. The solution evaporated to the consistence of honey, concretes on cooling into La Fevre's soluble cream of tartar, or *sal-gummosum*, which is the tartarus boraxatus of old authors.

BOREAL SIGNS. In astronomy, those signs of the zodiac north of the equator. They are Aries, Taurus, Gemini, Cancer, Leo, and Virgo. The sun passes successively through these during our summer months, from March to September.

BORING. A vertical section, made in the earth for the purpose of obtaining water. Also the operation of drilling holes by a circular motion of a cutting tool.

BORING COLLAR. An appendage to the lathe, used instead of the back poppit to hold one end of a piece of wood which is to be bored. It fits on to the bed of the lathe, and is fastened there by a screw or wedge beneath; its upper part is a round iron plate, with a circle of various-sized tapering holes in it. The plate is moveable around a central pin or bolt, so that any required hole may be uppermost; and when so placed uppermost it is tightened in that position by a screw behind. The piece of wood to be drilled is fixed to, and turned by the mandril at one end, and works in or against that hole of the collar which has been placed at top, and which from the proper arrangement of the holes is exactly even with it. A drill or boring bit is held to the centre of the wood, as it appears through the hole, and being forced forwards cuts a hole exactly up the centre of the wood which the mandril has put in motion.



BOROFLUORIDES. Compounds formed by the union of the fluoride of boron, or fluoroboric gas, with either potassium, sodium, or barium.

BOROFLUORIC ACID. A combination of the boracic and fluoric acids with water. It does not corrode glass, as the fluoric acid alone does, but is rapidly destructive to all organic substances, making them to appear as if scorched.

BORON. The metallic base of boracic acid, discovered in 1807 by Sir H. Davy. It is obtained by heating in a copper tube 2 parts of potassium, with 1 of boracic acid, previously fused and pounded. The fused matters are washed out of the tube with water, and the whole put upon a filter. The boron remains in the form of a brown, insipid, insoluble powder; a non-conductor of electricity; not acted upon by water, air, alcohol, ether, or oils, but when heated nearly to redness, it burns with difficulty into boracic acid, which is its only known combination with oxygen. It unites with chlorine and fluorine.

BORURETS. Compounds of boron with the metals.

Boss. Any round projecting mass of engraved stone-work, particularly applied to the knotted ornaments which are placed upon the intersection of the ribs of a groined roof.

BOSSAGE. A projection of stones laid rough in a building, to be afterwards sculptured or cut into mouldings.

BOSS'S FLOATING COIL. A simple galvanic apparatus, which when placed in acidulated water turns spontaneously, so as to

place itself north or south, or accordant to the magnetic meridian. It consists of a coil of wire, the ends of which are brought through the coil, and are terminated by two plates of metal, about an inch square each; one plate being of zinc, the other of copper. Now when this instrument is in use, it is necessary to suspend it by a thread, or support it by a cork at each end, lest it should sink. (See *Ampere*, *De la Rive*, and *Marsh*.)

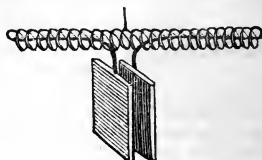

BOTTLE DIRECTOR. An electrical instrument, made out of a long narrow hollow flask, furnished with a brass cap, wire, and ball, the wire going down to the end on the inside; the inside is lined for a certain distance up with brass filings, by pouring into the flask a little gum water, and turning the flask about till the gum water touches every part of the glass where the filings are to reach, but no other part; then pouring in the filings they adhere. The outside to the same height is covered with tin-foil, pasted on. The instrument is charged in the same manner as the Leyden jar, (which see;) and will give a shock according to its capacity. It is scarcely used but for amusement.



BOTTLE, Electric. (See *Leyden Jar*.)

BOTTLE, Hydrogen Gas. An apparatus for making hydrogen gas. It is formed as follows, and is furnished with a bent tube, in order that it may be passed under the shelf of the pneumatic trough, and the gas thereby purified.

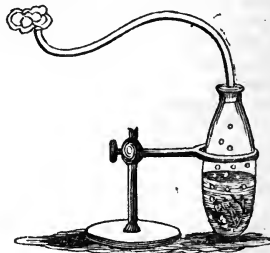

BOVEY COAL. Fossil wood, impregnated with petroleum or bitumen, and frequently containing pyrites, alum, and vitriol. It is

of a blackish brown color and lamellar structure, generally flexible when first dug up.

BOULDERS. Round pebbles, or small detached rocks.

BOULDER PAVING, is formed of unhewn round pebbles.

BOULDER WALLS. Those made of round flints, laid in strong mortar.

BOW COMPASS. A small pair of compasses for drawing small circles with ink.



BOW DRILL. A drill which is worked by a bow and string. (See *Drill Bow*.)

BOW PEN. A steel ruling pen; the part holding the ink being formed of two cheeks, bowed out towards the middle, and regulated by a screw.



BOW SAW, or FRAME SAW. (See *Saw*.)

BOW STRING BRIDGE, or TENSION BRIDGE. A kind of suspension bridge, the roadway being suspended from iron rods, and these depending from an iron arch, as represented below.



BOWTELLS. The shafts of a clustered pillar.

BOYLE'S FUMING LIQUOR. Hydrogen-retted sulphuret of ammonia.

BOYLE'S THERMOMETER. One of the earlier, and consequently more imperfect thermometers. It is, however, superior to any previously in use. It is simply a glass tube, open at both ends; one end cemented into a bottle half full of some liquid. The cement preventing any escape of the air which is above the liquid, any increase of temperature rarefies the air, and drives the liquid further up the tube; on the contrary, a decrease of temperature occasions it to subside. There was no scale attached to this thermometer.



BOYLEAN VACUUM. Such a vacuum as is produced by an air pump.

BOX CAMERA. (See *Camera Obscura*.)

BOXINGS OF A WINDOW. Two recesses into which inside shutters are folded, so as not to project into the room.

BRACE. A curved instrument, of iron or wood, to receive and move small boring tools, called bits.

BRACES, or STRUTS. The name given to the timbers of a roof which serve to support the principal rafters; the lower ends of them rest upon the king post or queen post.

BRACKET. A projection from a wall, for the purpose of supporting a statue, clock, or any other object. In architecture it is often synonymous with corbel.

BRADY'S BALANCE. An instrument for weighing common goods, upon the principle of the bent lever.

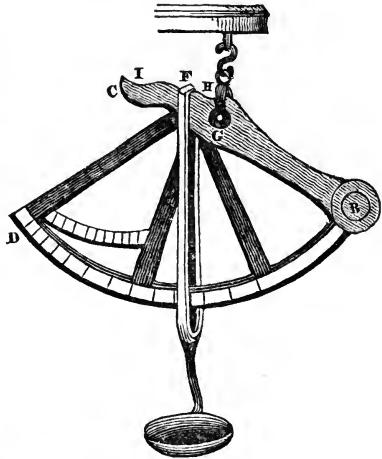

B C D is an iron frame, being much thicker and heavier towards B than in the other parts. It is supported upon a fulcrum G, and F is a moveable suspender, to which a scale or hook is attached, to receive the substance to be weighed. There are different positions, H F and I, in which this suspender may be placed, and for which there are distinct graduated scales, two of them following each other on the lower arc of the frame at D. When a weight is placed in the dish, the machine is turned round the fulcrum G, and the side C descends, until equilibrium is established, and the weight is read off from that scale which corresponds to the position of the suspender.

BRAHE'S SYSTEM. (See *Tychoean System*.)

BRAIDED. Any thing platted or twisted in an ornamental manner, such as hair, &c. The following ornament, used in architecture, is called braided.



BRAKE. A machine for separating the cuticle or outer skin from the flax plant.

BRAMAH'S HYDRAULIC PRESS. This most valuable instrument is represented below:—

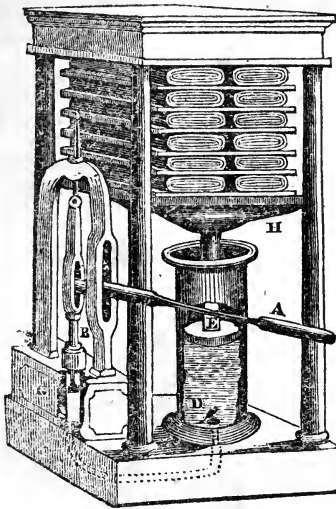

Its action depends upon the principle that fluids transmit pressure equally in all directions. A solid piston E is constructed so as to move water-tight in a cylinder. The space beneath the piston is filled with water, and communicates by a small pipe with a forcing pump, worked by the piston B, by means of the lever A, and by which the water, which is contained in the cistern G, is forced through the valve D into the large cylinder. The large piston being thereby driven up, carries with it the bed H, and presses closely together whatever may be above it. Whatever pressure is exerted upon B is transferred to E, and is increased according to the relative size of the two pistons. Suppose, for example, the piston at B to have a superficial area of 1 inch, and the large cylinder of 100 inches, then every 10 pounds pressure put upon B will be increased by E 100-fold, and become 1000 pounds; and as a person may exert a force of 500 on the lever, his weight alone will give a pressure 1000×500 pounds, or more than 22 tons, and that with a pump, the large cylinder of which is not more than 12 inches diameter; and by decreasing the smaller tube, from 1 inch diameter to half an inch, the power will be increased four-fold, or to nearly 90 tons.

BRANCA'S ENGINE. One of the earlier steam engines, invented by Giovanni Branca in the beginning of the seventeenth century. The following is a picturesque view of the engine, as applicable to pumping.

A is an ornamental boiler, in the shape of a bust. B is a float wheel, turned round by the steam issuing from a pipe inserted into the mouth of the figure. The wheel B com-

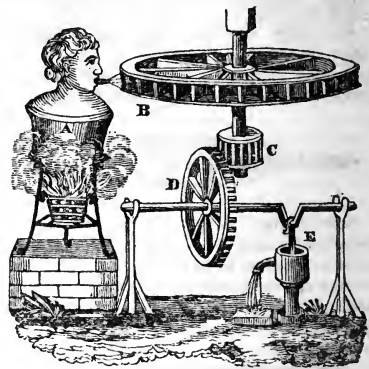

municates motion to the trundle C, that to the wheel D, and also to the pump rod E. It was employed by Branca in grinding, or rather in giving motion to the pounders of a mill for pounding drugs.

BRANCH CHUCK. A chuck formed of four branches, turned up at the ends, and these ends furnished with a screw to each. The use of this chuck is almost superseded by the surface chuck, which is not only applicable to the same purposes, but many others.

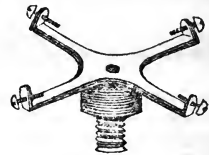

BRANCH OF A CURVE. Such parts of it as when produced do not return into the curve again, such as the legs of the parabola and hyperbola.

BRANDRITH. A fence round the mouth of a well.

BRANDY. A well-known liquor, distilled from spoiled wines, husks of grapes, &c., chiefly in the wine countries. Its peculiar flavor arises from the empyreumatic oil of the fruit. It is like all distilled liquors perfectly colorless, until rendered dark with burnt sugar.

BRASS. An alloy, consisting of different proportions of copper and zinc; the zinc being about one-third the weight of the copper.

BRAZIL WOOD. The wood of one species of the *Cæsalpina*. It gives out its color to water, producing a fine, though fleeting red: it is that from which red ink is manufactured.

BRASSES. Monumental slabs of brass, much used in the middle ages; and which from the accuracy of the engraving of costume and inscriptions are valuable in ascertaining dates, &c. They were general towards the close of the fourteenth century.

BRAZING. The soldering together of metals by means of an alloy, of which brass forms the principal ingredient. On account of the great heat requisite to melt brass, it is not used as a solder, except for the metals which are fused with difficulty, such as iron, copper, &c. Articles of jewellery, though the parts are joined together with brass, are said to be soldered, and not brazed.

BRANCHED WORK. A name given to the carved and sculptured leaves and branches in monuments and friezes.

BREAKING SQUARE. A small square phial, holding about 3 ounces, and made of exceedingly thin glass. The use of the breaking square is to show the elasticity and pressure of the atmosphere; thus, fasten to the mouth of one of them a stop cock, fitting the hole on the plate of the air pump, to which attach it; then extracting the air from within, the external pressure will crush the breaking square; or else stop up the mouth of another, and put it within the receiver of the pump, exhaust the air from around it, when the pressure of the air within the bottle will burst it.

BREAK, or CONVOY. A drag applied to the wheels of railway carriages, the fly wheel of cranes, &c., to check their velocity in passing down hills, &c.; also to stop the motion of machinery. It is simply a block of wood, made to press upon one of the wheels in motion, by means of a lever held in the conductor's hand. In wheel carriages it is an iron shoe, in which one of the wheels is placed, suffering that to slide along the road rather than the wheel to turn.

BREAK. A projection from, or recess, in the wall of a building.

BREAK JOINT. (See *Bond*.)

BREAKWATER. An artificial embankment, made to break the force of the waves, to protect the entrances of harbours, &c.

BREAKWATER GLACIS, or STORM PAVEMENT. A stone paving next the sea. In the erection of piers they are mostly much sloped, and built of large stones, that they may resist better the force of the waves.

BREASTS. The name given to the bushes connected with small shafts or spindles.

BREASTING. The circular sweep of masonry which surrounds the shuttle side of a breast wheel.

BREAST PLATE. A small piece of steel, with holes to receive the end of a drill. When in use it is named breast plate, because of being held against the breast.

BREAK WHEEL. A wheel with breaks or

wipers upon the circumference. The use of such a contrivance will be seen by the cut, in which the breaks are employed to raise and let fall alternately the handle of a sledge hammer.

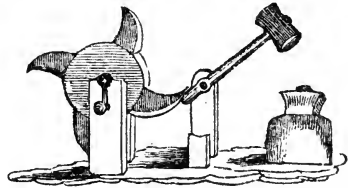

BREAST WHEEL. A water wheel, which receives its motion from a stream of water flowing on to the breast or side of it, and then descending, bears by its weight upon the lower part of the wheel, as represented below.

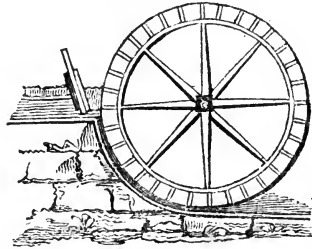

The quantity of water is regulated by a sluice at the end of the stream. The channel of brick-work in which the wheel turns, and which is called the breasting, is semi-circular, and so close to the wheel, that the water has no passage but by the wheel itself. The wheel is made of float boards, which have backs to them, to prevent the escape of the water towards the inside of the wheel.

BRECCIA, or BRECCIA MARBLE. A conglomerated stone, seemingly made up of broken fragments of various stones united together by a hardened cement.

BREQUET'S PYROMETER, or METALLIC THERMOMETER, consists of a helix formed of three strips of three metals, of different degrees of expansibility. The exterior strip is of silver, the interior of platina, and between them is one of gold. Two only are necessary to the perfect action of the instrument, but from the difference of the expansibility between silver and platina, they would be liable to separate by sudden changes of temperature; and a thin plate of gold, which is of intermediate expansibility, is interposed. The whole forms a wire of about one hundredth of an inch in thickness. The upper extremity of the helix is fastened to the extremity of the brass arm B, which by its form insulates the helix, and permits its

coiling and uncoiling freely. To its lower extremity is attached a gold needle, which moves round a graduated scale of degrees, and thereby indicates the degree of temperature; it being proved by experiment that equal increase of temperature produces equality of metallic expansion. The sensibility of the instrument is said to be very great, and it is the more valuable because of not being affected by changes in the density of the atmosphere, as the common thermometer is.

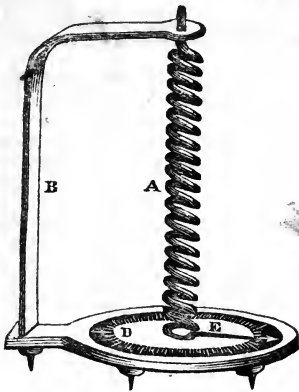

BREECH, or BREECHING. That part of a gun barrel or cannon, which closes it at that end nearest the touch-hole.

BRETSUMMER. BRESSUMMER. A beam placed horizontally to support an upper wall or partition. The lower beam of a church gallery, and that over a shop window, are brestsummers.

BREWSTER'S CIRCULAR PEARL MICRO-METER, consists of a ring of mother of pearl, fixed on its outer edge to a diaphragm D D, at the end of a piece of brass tube, which is capable of being adjusted to the anterior

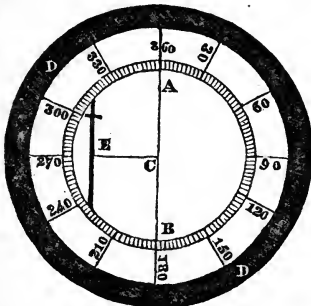

focus of the object glass of a microscope or telescope. The inner circumference of the pearl is divided into 360° degrees, or equal

parts. The greatest angle that this micro-meter will measure must first be ascertained by experiment, which will be according to the length of the focus, compared with the internal diameter of the pearl ring. This being known, a table is easily constructed to show, by inspection, the angle subtended by any two points or degrees of the circumference the object to be measured will reach, as is seen at E. The whole diameter or A B being known.

BREWSTER'S COMPOUND LENSES. Contrivances to prevent the achromatism of the ordinary lenses of microscopes, at the same time that light should not be lost. They are of two forms; in one a channel is cut round the sides of a solid lens, as represented in Fig. 2. In the other form, two double convex lenses are made use of, so placed as to form a double concave lens in the centre, which centre is filled with a fluid differing from glass in its refractive and dispersive power, so as to correct both the spherical and achromatic aberration. This combination is shown in Fig. 1.

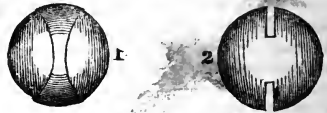

BREWSTER'S FLUID LENSES. Dr. Brewster describes the following as the best method of constructing fluid microscopes or lenses. "Take Canada balsam, balsam of copaiva, or pure turpentine varnish, and drop either of them on a parallel piece of glass, when a plano-convex lens will be formed. The power may be varied by the quantity of fluid employed, or by allowing the plate of glass to be horizontal with the drop above or below it; thus, if the plate be uppermost, the gravity of the fluid will make it more convex; if the drop be above the plate the lens will be flattened. When the first of these substances is used it soon hardens, and the lens is very durable." Dr. Brewster further informs us, that he has made both the object and eye glasses of compound microscopes in this manner, which performed extremely well, and lasted a considerable time.

BREWSTER'S Teinoscope, Kaleidoscope, and Object Glass. See these names.

BRICK. A kind of artificial stone, formed of a mixture of clay, sand, and ashes, hardened by long continued burning.

BRICK-NOGGING. A wall in which bricks are built up between quarterings, so as to fill up the interstices; this work is usually the thickness of a brick.

BRICK, OIL OF. The liquor which comes over in the destructive distillation of various of the fixed oils; these are decomposed at a little above their boiling point, or at about

600°; the vapour that now passes over is acrid, sour, and empyreumatic. It is called oil of brick because a brick was often soaked in the oil, and then submitted to distillation, it being thought that it derived some part of its peculiar properties from that circumstance. It is much used by seal engravers and gem cutters as an oil.

BRIDGE. A pathway erected over a river, a road, canal, &c., in order that a passage may be made from the one side to the other. Bridges may be made of timber, iron, brick, or stone. The English excel all nations in their bridges; Waterloo bridge and London bridge, the suspension bridge across the Menai Straits, and numerous others, are the admiration of the world. The extreme supports of a bridge, whether consisting of one or of many arches, are called *abutments*, or *butments*. The parts upright between these, if any, are called *piers* or *pillars*. The foundations upon which these rest, if widened out so as to throw off the force of the stream, are called *starlings*, and the fences on the sides of the roadway are called *parapets*.

BRIDGE STONE. A stone laid from the pavement to the entrance door of a house over a sunk area, not supported by an arch.

BRIDLE-REIN PACKING. A term applied by engineers to signify the placing of a strip of leather, or a loose rope of tow, around a piston, to make it fit tightly to the cylinder in which it works. It was used in Beighton's steam engine.

BRIGHT. Lucid; glittering. A picture is said to be bright when the lights so much prevail as to overcome the shadows, and are kept so clear and distinct as to produce a brilliant appearance.

BRIMSTONE. (See *Sulphur*.)

BRIONIN. A crystallizable principle, found in white briony; procured by treating the expressed juice with ammonia.—*Vanquelin*.

BRITISH GUM. The trivial name given to starch, altered by calcination in an oven, whereby it assumes the appearance and acquires the properties of gum. It is used as a dressing to numerous woven fabrics, as well as to thicken the colors used by the calico printer.

BRITANNIA METAL, or TUTANIA. Melt together 4 ounces of plate brass, and 4 ounces of tin; when melted add 4 ounces of bismuth, and 4 ounces of regulus of antimony.

BROACH. An old English term for a spire; also used by some writers for the small turrets or spires which surround a larger one.

BROKEN NUMBER. The same as fraction.

BRONZE consists of from 6 to 12 parts of tin to 100 parts of copper. This alloy is heavier than copper, and possesses more tenacity: it is more fusible, and less liable to be altered by exposure to the air. It is

used for medals, different articles of ornament and domestic use, cannon, &c.

BRONZE, also denotes any piece of sculpture made of bronze metal, as statues, busts, &c., whether in imitation of the antique, or representing a modern prototype.

BRONZE, TO. To give to wood, plaster, metal, &c., such a surface as to make them appear as if made of bronze. This is done by means of a bronze powder; the article being first painted and varnished, and the powder then sifted over such parts of it as are to appear metallic. It is usually done on metallic articles, such as lamp stands, &c., by slightly warming them, and then washing them over with a liquid which slightly corrodes the surface, (See *Browning*, &c.)

BRONZE LIQUID. Melt in 14 ounces of vinegar 2 drams of sal-ammoniac, and half a dram of salt of sorrel, (binoxalate of potass;) rub this over the object to be bronzed with a soft brush, till the required tint is obtained. Liquid to imitate antique bronzes is made by dissolving 1 part of sal-ammoniac, 3 parts of cream of tartar, and 6 parts of common salt, in 12 parts of hot water; mixing with the solution 8 parts of a strong solution of sulphate of copper.

BRONZE POWDERS are metallic powders capable of communicating a bronze-like color to those objects over which they are spread. Aurum musivum, or the bisulphuret of tin, is the most common, and is used for plaster figures, &c. Dutch leaf ground to a paste with honey, and afterwards washed away from the honey, makes a fine bronze powder. Copper powder, as precipitated from a solution of the nitrate of copper by clean sheets of iron, is another.

BRONZING SALT. Chloride of antimony; so called from its general use in browning or bronzing gun barrels, &c.

BROOCH. A term used by painters to signify a painting all of one color, as a sepia painting, an Indian ink painting, &c.

BROWN. A color between red and black, or yellow and black. (See *Umber*, *Spanish Brown*, *Bistre*, *Cologne Earth*, &c.)

BROWNING, or BRONZING, gun barrels, or other iron articles, may be done by washing them over with dilute, or muriatic, acid. When somewhat corroded, they are to be rubbed smooth and varnished:—or the following method may be recommended; Grind up the butter (chloride,) of antimony, with olive oil, rub it upon the iron slightly heated; and afterwards expose it to the air, till the desired color is obtained. It is afterwards to be varnished.

BRUCIA. An alkaline substance, found in the spurious angostura bark. It may be made as follows:—boil the bark in acidulated water, treat with quick-lime in excess, to decompose the fluid; treat the deposit with

alcohol and distil; the brucia will remain. (*Magendie.*)

BAUNSWICK GREEN. Chloride, or sub-muriate of copper; it may be made by adding oxide of copper to a solution of chlorine, or by exposing to the atmosphere slips of copper partially immersed in muriatic acid. It is a color extensively used by the house painter.

BRUSH, Electrical, signifies the brush-shaped emanation of electric light, which issues from all sharp or pointed bodies which are strongly electrified positively.

BRUSH WHEELS. Such wheels as move each other without cogs or teeth. Often the rubbing surfaces are covered with stiff hairs as a brush is formed, hence the name; but sometimes they are covered with woollen cloth or buff leather. For light pieces of machinery, where noise would be disagreeable, such wheels are valuable; for example, in those machines used by astronomical lecturers to illustrate the subject of planetary motion, &c. Brush wheels may communicate motion either in the same direction as the wheel from which the impulse arises, as is seen in F, or the motion may be continued at a different angle, as is seen at A and E. In the cut it will be seen that the wheel C, moving upon the spindle D, turns at the same time the wheels A, E, and F.

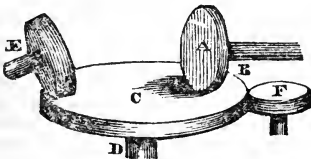

BUCKET, Electrical. A small metal bucket, having at the bottom a tube, perforated with a fine hole. Water put into this bucket will under ordinary circumstances fall in single drops from the hole, but when the bucket is suspended from the prime conductor of an electrical machine, and



strongly electrified, the water issues in numerous streams, which are luminous in the dark.

BUCKET ENGINE. A substitute for an

over-shot water wheel, and far superior where the fall of water is considerable, and the supply limited.

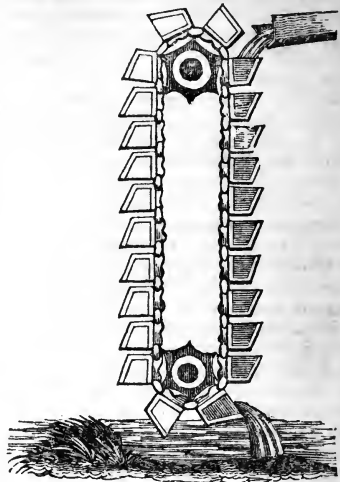

An endless chain, carrying a series of buckets, is made to revolve on two wheels, A B, called *rag-wheels*. The water flows into the highest bucket, and when it descends the next bucket takes its place and is likewise filled, and thus every bucket on one side is filled, while those on the opposite side, being inverted, are empty; the chain of buckets is therefore constantly carried round by the weight of the water.

BUDE LIGHT. A lamp in which the flame is urged to an intense brilliancy, by a stream of oxygen gas being made to permeate the centre of the flame. The flame thus urged gives the most vivid light, so much so that one of a quarter of an inch diameter, and which receives the oxygen through an extremely minute orifice in the centre of the flame, yield an infinitely greater light than many candles. This light is the invention of Mr. Gurney, and is called the Bude light from his place of residence.

BUFF. A small wheel, covered with buff leather, used to polish cutlery upon, after having been ground.

BUFF STICK. A piece of wood, covered with buff leather, used for polishing.

BUFFING APPARATUS. A contrivance for receiving the shock of a coalition between



railway carriages, consisting of powerful springs, inclosed in a case; the springs being compressed at the time of a coalition

by a rod attached to them, and which proceeding outwards, is terminated by cushions, called buffs, to receive the first impact.

BUFFON'S BUILT-UP LENSES. The difficulty of procuring lenses of glass of a very large size, such as is necessary for burning glasses, induced Count Buffon to recommend them to be made of separate pieces of glass, as represented in the cut below, which shows the front and the side view of one of the built-up lenses; or, as Dr. Brewster calls them, *polyzonal lenses*.

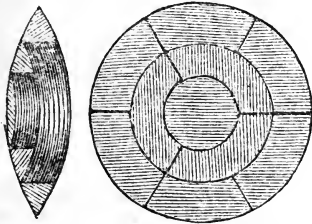

The advantages of these lenses are, the greater facility of getting pieces of glass to make the various zones, than to make a solid lens; the less expense to repair it if a part should be imperfect or broken; the less aberration there is in a lens of this description than there would be in one made of a solid piece of glass; also the less expense of grinding such a lens, because of the large size of the tools requisite for a solid lens: Count Buffon merely recommended such lenses; Dr. Brewster first made them.

BUFFON'S BURNING MIRROR was a concave mirror, 6 feet in diameter, composed of 168 small mirrors, or flat pieces of looking glass, 6 inches square. This instrument was adapted to burn an object either below or above it, each mirror being moveable, so that by the means of three screws it might be set to a proper inclination for directing the rays of the sun towards any given point. Wood by this burning mirror was burnt even by the weak sun of March, at a distance of 150 feet, and silver melted at 50 feet. The burning mirrors once used by the celebrated Archimedes, were of a similar description, though in all probability made of polished metal.

BULL WORK. The cutting out and in-laying of fine strips of brass, silver, ivory, &c., on the surface of cabinet and similar work.

BUILDING BEAMS. A term used by carpenters to signify the making up of a very large beam, by pinning and bolting together several smaller ones.

BULLET. To alter the wards of a lock in such a manner that they may be passable by more than one key.

BULL'S EYE. A small circular, or elliptical window; chiefly applied to those in the gable or pediment of a building; also any similar shaped recess in such places, even when filled by a clock.

BULL'S EYE, or DEAD EYE. A small oval block of hard wood, without shaves, having a groove round the outer side, and one or more holes in the middle. The bull's eye spindle, or under spindle of the air pump rod, in the common parallel motion of a steam engine; so called because the air pump rod must pass through a hole in it, which is the bull's eye.

BUNDLE PILLAR. A term sometimes applied to a pillar, or pier, with others of smaller dimensions arranged round, and attached to it.

BUOY. A floating mark to point out the position of objects beneath the water; also any light body used to support in the water another body, which would otherwise sink.

BURNING GLASS. A convex lens, because it, from its nature, refracts the parallel rays from the sun, and collects them into a focus, thereby so concentrating their power as to scorch, or melt, the object upon which they are thrown.

BURNING MIRROR. A bright concave surface of metal, or other material, which collects into a focus any rays of heat thrown upon it, and burns, or melts the substance placed within the focus; so also such mirrors collect heat from a certain focus, and transmit it from their surface in parallel lines. If two such mirrors be opposite each other, and a heated ball placed in the focus of one, it will heat any object placed in the focus of the other; as is represented in the following cut, where A is a red hot iron ball, and B a cup of spirits of wine, which it has inflamed.

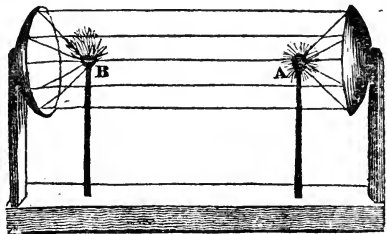

As burning mirrors may be made of any focus, they may be made to inflame combustible materials at any required distance, even miles away. The most refractory bodies have been melted in the focus of a burning mirror exposed to the sun, when subjected to its influence for only a few seconds. (See *Buffon*.)

BURNING MOUNTAIN. (See *Volcano*.)

BURNING ZONE. The torrid zone.

BURNISH. To polish any thing by rubbing it with some smooth material harder than itself.

BURTON'S, or SPANISH BURTON'S. A series of pulleys, in which every pulley contains but a single sheave, and in which there are as many ropes as moveable pulleys. Much power is gained by a construction of this kind; but the peculiar form, and less compactness of Spanish Burton's than of the ordinary block, makes them unavailable on ship-board, or for general purposes; besides which, they are much more expensive.

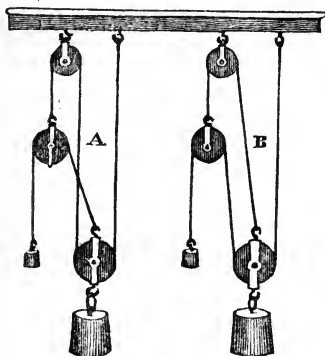

BURNISHER. A tool for burnishing. Burnishers are of various shapes and materials, according to the purpose to which they are to be applied. The engraver's burnisher is of steel, with a smooth tapering point; it is used by him to take out false scratches, to soften what has been too deeply engraven, &c. The burnisher used by the gilder is made of agate, porphyry, or other hard stone; those used in the general polishing of iron goods, is of hardened steel.

BUSH. A hole in the nave of a wheel; or more properly the steel, bell-metal, or brass tube, or hollow box, which fits into the centre of the wheel; to bear better than the wheel otherwise would do, the friction of the axletree.

BUST. In sculpture, that portion of the human figure which comprehends the head, neck, and breast, with or without the shoulders.

BUTMENT. A contraction of abutment.

BUTMENT CHEEKS. The solid parts on each side of a mortice.

BUTTER OF ANTIMONY. Sesquichloride of antimony.

BUTTER OF ARSENIC. Chloride of arsenic.

BUTTER OF BISMUTH. Chloride of bismuth.

BUTTER OF CACAO. An oily concrete matter, obtained from the chocolate nut. In appearance it much resembles mutton suet,

and is made by bruising the nuts, and boiling the pulp in water, when the oil will float to the top of the water, and may be taken off when cold. It is used in pomatums.

BUTTER OF TIN. Perchloride of tin.

BUTTER OF ZINC. Chloride of zinc.

BUTTERFLY VALVE. A double clack valve, as follows:—The two sides are fixed to a hinge in the centre, and open in opposite directions, either over a round hole, or over two holes; it is a useful valve, where there is not height for the play of a flat valve covering the whole orifice



BUTTERY HATCH. A half door between the buttery, or kitchen, in old mansions, and the hall.

BUTTRESS. A projection from a wall to create additional support and strength. Buttresses partake of the particular style of architecture of the building. In the Norman style they projected but little. In the early English the projection was increased. In the pointed arch style the buttress became heavy; it was therefore soon afterwards perforated. *Flying Buttresses* next succeeded;

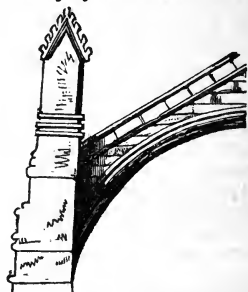

in the decorated Tudor architecture the utmost elegance was given by panels, fretwork, pinnacles, niches, &c.

BUTURATES. Combinations of buturic acid with various bases. They are inodorous when dry, but when moist smell strongly of butter.

BUTURIC ACID. A limpid, colorless acid, resembling oil, obtained from butter: it unites with water, and with alkaline, earthy and a few metalline bases, forming buturates.

BUTYRINE. A peculiar oleaginous matter, procured by M. Chevreul from butter, which serves to distinguish it from animal fats. It congeals at 32° Fahr.; dissolves in all proportions in boiling alcohol, its solution gradually becoming sour. When buturine is saponified, it yields three distinct acids, termed the buturic, the caproic, and the capric acid.

The third letter of the alphabet in most European languages; it has two distinct sounds—a soft sound, like *s*, before *e*, *i*, *y*, as in *ocell*, *city*, *cylinder*; and a hard sound, like *k*, before *a*, *o*, *u*, *l*, and *r*, as in *cat*, *cot*, *cut*, *claim*, *cramp*.

Combined with the letter *h* it has many sounds, as is exemplified by *chord*, *china*, *chivalry*, *choir*, &c.; and it is silent before *t* and *z*, as in *Czar*. Used as a numeral it signifies 100. In music, the note thus called is placed between the second and third clef line, and is represented by the sound of the word *ut* or *do*. Prefixed to printed or written music it signifies common time. In contractions, and on monuments and coins it is put for *Cæsar*, *Caius*, *consul*, *canto*, *condemno*, &c.; besides being often interchanged for *q* and *g*, as *cotidie* for *quotidie*, *lecciones* for *legiones*, &c.

CABLE. A rope, or chain, of large size, by which ships are held to their anchors, or moorings. Cables are always made of the length of 120 fathoms, or 240 yards. Their diameter varies according to the purposes for which they are intended—this is measured in inches; thus we say, an 18-inch cable, a 12-inch cable, and so on.

CABLE MOULDING. A round moulding cut in imitation of the twisting of a rope; much used in the Norman architecture.



CABLING. The shafts of columns are cabled when the flutes are partly filled by cylinders; these seldom extend about one-third of the shaft in height.

CABLE STOPPER. An instrument, patented by Mr. S. Burnett, to prevent sudden strains upon cable fastenings, whereby they are so often torn away. It consists of a spiral spring, inclosed in a box. The box is fastened to the ship, and the cable to an arbor passing through the spring, and compressing it when any unusual strain occurs.

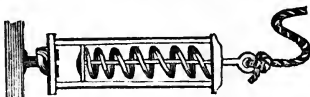

CACAO, BUTTER OF. (See *Butter*.)

CADEL'S FUMING LIQUID. An oil-like liquid, impregnated with metallic arsenic, water, and pyro-acetic spirit; obtained by

distilling a mixture of acetate of potassa and arsenious acid.

CADMIUM. A metal discovered about 1818. It occurs chiefly in Silesia, in several ores of zinc: it has the color and lustre of tin, and is susceptible of a fine polish. Its fracture is fibrous; it is in texture soft, easily bent and cut, malleable and ductile, and fuses at a heat much less than redness; its vapours have no smell. In the strong acids it dissolves with disengagement of hydrogen, forming colorless solutions. The only oxyde is of a brown color; its sulphuret is of a fine orange.

CADUCEUS ROCKET. (See *Rocket*.)

CAFFEIC ACID. An acid precipitated along with tannic acid, by treating decoction of coffee with acetate of lead.

CAFEINE. A principle similar to narcotine, discovered by Robiquet in coffee. It is white, crystallizes in long silky filaments, is volatile, and soluble in alcohol and boiling water.

CAGE. In carpentry, an outer work of timber, inclosing other works within it, as the case of a stair is the wooden wall which surrounds it.

CAHINIC, or CAHINCIC ACID. The bitter principle of *caina* bark, procured from the alcoholic extract.

CAIRNGORM, or CAIRNGORUM. A species of quartz, usually of a slightly brown color.

CAISSON. A large flat-bottomed box, built of strong timber, made water tight, and sunk to the bottom of a river; intended as a frame-work in which the workmen may construct the foundation of a bridge. When this is built above high-water mark, the sides of the caisson are detached, the bottom of it remaining, and forming part of the foundation itself. Westminster Bridge is built upon caissons.

CAISSONS. The sunk panels in flat or vaulted ceilings, soffits, &c.

CAKING. The adhesion of one thing to another; occasioned by compression, subsidence, evaporation of watery particles, swelling by fire, &c.

CAIAMANCO. A sort of woollen stuff of a shining appearance, checkered in the warp, so that the checks are seen only on one side.

CALAMINE. An ore of zinc, chiefly used in making brass.

CALC-SINTER. The incrustations of carbonate of lime upon the ground, and stalactites, as attached to the roofs of caverns, &c. In all cases arising from the deposition of the lime held in solution in the water.

CALCAR, or FRITTING FURNACE, is a furnace in which the ingredients used in glass making are submitted to a roasting heat, previous to their being placed in the glass pots, where they are to be fused together. This is necessary in order to drive off the impurities, particularly the carbonic acid which the ingredients may contain.

CALCAREOUS EARTH. Any friable kind of limestone, chalk, &c. In chemistry it signifies pure lime.

CALCAREOUS SPAR. Crystallized carbonate of lime. One of the purest varieties has the name of Iceland spar, though it is not peculiar to that island. It is remarkable for having the power of double refraction, as is represented in the following crystal:—

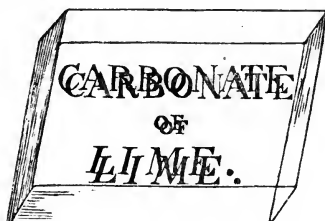

CALCEDONY. A hard flinty stone, often cut into seals. Cornelian is one of the species of calcedony, so is the onyx stone.

CALCHANTUM. The ancient name of sulphate of iron.

CALCINATION. The process by which some bodies are rendered capable of being pulverized; it consists of exposing the substances to a strong heat, so as to dissipate the water of crystallization, and other volatile portions, and thus destroying the cohesion of the solid parts.

CALCIUM. The metallic base of lime, first separated from the earth by Sir H. Davy. Lime is an oxyde of calcium. The salts of lime are now more properly called the salts of calcium, as we speak chemically of the chloride of calcium, &c. (See *Lime*.)

CALCOGRAPHY. The art of engraving.

CALCULUS. Among mathematicians is a certain method of performing mathematical calculations, investigations, &c. Thus we say, *literal calculus*, which is the same as algebra; *numeral calculus*, the same as arithmetic; and so on for others.

CALEFACTOR. A small cooking stove, invented and patented by Mr. Tozer, for the use of small families in the summer season. It consists of a double cylinder of tin, holding water between them; the centre being then dry, cooks any thing put within it, just as is seen in a common glue pot.

CALENDERING. The operation by which all accidental wrinkles are removed from various kinds of cloth, and their surfaces rendered smooth and free from wrinkles. The common calendering machine resembles a mangle, but is greatly larger and heavier.

CALENDULIN. A matter somewhat analogous to gum tragacanth, obtained by Geiger from the petals of the marigold.

CALKING. A term used by artists to denote drawings traced from a print or design, by rubbing the back of the print with red or black chalk, and laying it on a sheet of clean paper, with its chalked surface next to the paper; then tracing all the lines of the drawing, or print, with a point, leaves the impression of the point. Instead of thus spoiling the print, it is better to put a sheet of chalked paper between the print and white paper.

CALIBER, CALIBRE, or CALIPER. The diameter, whether external, or internal, of any round body; thus we speak of the calibre of a rocket, cannon, shaft, &c.

CALIBERS, CALIPER COMPASSES, or simply CALIPERS. A sort of compass, made with bowed, or arch legs, for the purpose of taking the diameter of any round object.

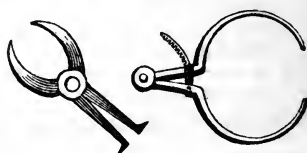

CALICO PRINTING. The art of producing upon calico and other similar cotton fabrics, designs or patterns, combining a variety of colors, so as to produce a pleasing effect.

CALIPPIC PERIOD. A period of 76 years, continually recurring; after which it was supposed by Calippus, that the lunations, &c., of the moon would return again in the same order, which, however, is not exact, as it brings them too late by a day in 225 years.

CALLAN'S COIL. An electro-magnetic apparatus, consisting of a wooden bobbin, upon which is wound about 600 feet of copper wire, about as thick as bell wire, and covered with silk; the inner and outer end projecting through the sides of the bobbin. This is called the primary coil; over it is wound 1600 feet of much thinner wire, also covered with silk, and quite unconnected with the inner coil, and with its ends also projecting; this is called the secondary coil. This compound coil of wire forms a part of all coil machines, such as *Bachhoffner's*, *Bird's*, *Clarke's*, *Wright's*, *Sturgeon's*, &c., (which see,) or it may be used without them. The galvanic battery being connected with the two ends of the primary coil, and a person made to take hold of the two ends of the secondary coil, he will feel an intense shock at the moment contact with the battery is made, and if a fine wire be made part of the *battery* circuit, it will be rendered red hot, much more readily than without the coil. It is to be added, that a bar of iron, or still better, a bundle of iron wires, should be placed within the inner coil, as represented in the

figure, where A is the bundle of wires ; B C binding screws at the ends of the primary coil ; D E the wires from the battery ; F G binding screws at the ends of the wires of the secondary coil.

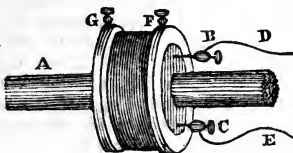

CALLAN'S ELECTRO-MAGNETIC REPEATER, is represented below. A is a scape-wheel, moving the bar B, and with it the arbor C, and the wire which is fastened to it D E ; the arbor has a wire reaching some mercury in the cup F ; while the ends of D E are bent at right angles, so as to dip alternately into G H ; G and H are connected together by a wire beneath the stand. To use the instrument, connect one pole of a galvanic battery with the cup F, and the other pole with either the cup G or H, it is immaterial which ; upon turning the handle, very rapid connection between the poles of the battery will be made and broken.

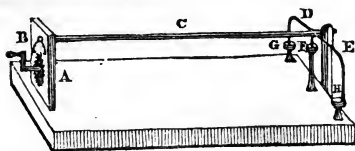

CALLIPERS, see *Calibers*.

CALOMEL. Proto-chloride of mercury, frequently called sub-muriate of mercury, or mild muriate of mercury.

CALORIC. An imaginary fluid substance, supposed to be diffused through all bodies ; and the sensible effect of which is termed heat ; with chemists, *caloric* is properly the matter producing the sensation, and *heat* the sensation itself. The terms, however, are often confounded ; the word heat being used both for the cause and the effect.

CONDUCTORS OF CALORIC. (See *Conductor*.)

CALORIC, *Free or Sensible*, and *Latent*. That portion of the fluid matter of heat which exists in any body, without producing any effect, is called *latent* ; that which produces an effect being termed *free or sensible caloric*.

CALORIC, Specific. Although all substances possess some quantity of caloric which is latent, yet the quantity in each varies with the nature of the body. The relative proportion that any body retains without the effects being sensible, is termed the *specific caloric* of that body, and its power of retention is called its *capacity* for caloric.

CALORIFIC RAYS, are those rays or emissions from the sun, or any burning body, which impart the sensation and other effects of heat.

CALORIFIC REPULSION. Heat.

CALORIMETER. An instrument for measuring the quantity of heat contained in any body, the temperature of which is above 32° . It consists of two metallic vessels, placed one within the other, with a space between them ; each vessel being furnished with a stop cock at bottom. The vessels have each a closely-fitting cover, which covers have also a space between them. If the space between the vessels be filled with melting ice, or snow, this will gradually melt away, and the water formed run out by the cock A ; by this arrangement the temperature of the inner vessel will always be that of the freezing point, or the thawing point, which is the same thing. A third vessel B is now placed within the second, and the space between the two inner vessels also filled with melting ice. It is evident that the ice contained in the second vessel, cannot be affected by the external air ; therefore, when a heated substance is placed within B, it will melt a certain proportion of the inner stratum of ice, the quantity of which melted, and consequently the quantity of heat parted with, to lower it to 32° , is ascertained by the quantity of water which flows out of C.

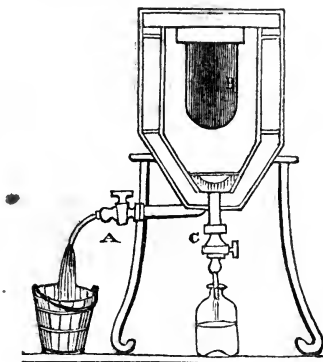

CALORIMOTOR. A galvanic battery formed of a single pair of extremely large plates of metal, such plates consisting of smaller plates soldered together so as to act in union, or as one plate ; (this was the structure of the first battery of this description, made by the inventor, Dr. Hare, of Philadelphia ;) or else consisting of two long plates, one of zinc, the other of copper, coiled round each other, as suggested by Mr. Pepys, and as represented below. This compound coil is suspended over a tub of acidulated water, into which it can be lowered at pleasure. The name

calorimotor, or the mover of heat, is derived from the extraordinary power the instrument possesses in deflagrating the metals, and otherwise producing heat and combustion.

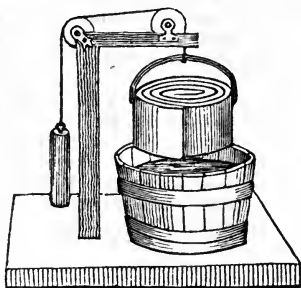

CALOTTE. A concavity in form of a cap or niche, to diminish the height of a cabinet, alcove, &c., when it would be too high for the width of it.

CALX. An old word to signify any earthy substance left after burning; as the oxyde formed upon melted metals, such as lead; the dross left in the glass furnace, the iron furnace, &c. In later times, calx is applied chiefly to signify lime.

CAM, or CAM WHEEL. A wheel, or part of a wheel, formed so as to move eccentrically, or else made with either projections, or depressions on its circumference, of such a nature as to produce a reciprocating and mostly interrupted motion in some other part of machinery attached to or working against it; for example, letter A represents a wheel furnished with four cams on its circumference, and therefore, during every revolution it would lift up the rod B four

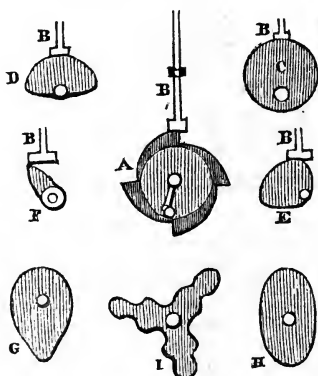

times, the rod falling by its own weight, or in consequence of a spring attached to it, as soon as each cam has passed it. The eccentric wheel, or cam, C, in each revolution would

lift the rod gently up and down, without any sudden recoil; the cam D would lift it suddenly up, then let it rest for half a revolution, then let it down, and then let it rest again. The cam wheels, E, F, G, H, and I, will each give a different motion to whatever is pressed against it. It is by means of cams that most irregular motions are given to machinery, particularly in those curious automata, where writing, drawing, &c., is imitated by a mechanical figure. Cams are also the principles upon which the rose and similar engines are constructed.

CAMBER. A slight degree of arching which is usually given to the cross beams of a roof, as an allowance for their settling, which they do in a slight degree when the weight of rafters and tiling comes upon them; also an arch at the top of an aperture, or on the top of a beam; hence camber windows.

CAMBER BEAM. (See *Beam*.)

CAMBRIC. A kind of very fine and rather thin linen fabric, first made at Cambray, whence its name. It is in England sometimes made from cotton, and at other times linen thread.

CAMERA LUCIDA. An instrument in very general use by artists, and others, in drawing landscapes, machinery, &c., as well as for copying and reducing complicated drawings. It was the invention of Dr. Wollaston in 1807. It is thus figured and described.

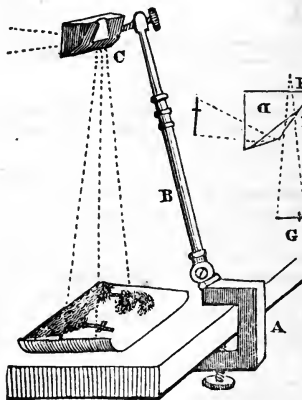

A is a clamp, fastening the upper part to the table, or to a drawing board; B a stem of two or three joints, sliding into each other, after the manner of a telescope. C is a prism shaped as seen more clearly in D. The front side of the prism is directed to the object at a distance; the stem is drawn out according to the size of the intended drawing. The eye looking now down upon the top of the prism will see the distant object represented below

through the prism. This is, however, not sufficient; it is necessary that a pencil held in the hand should be also visible; to see this at the same time as the picture, the eye is directed half over the edge of the prism, and half on the side of it, and in order that the eye may be obliged to maintain the just position, and not be diverted by extraneous light, there is placed on the upper side of the prism, a thin plate of brass, with a hole cut in it, through which the vision is directed. This instrument requires considerable practice, that the artist may see the object and the pencil both at the same time clearly.

CAMERA OBSCURA, or DARK CHAMBER.

An amusing optical instrument, invented by the celebrated Baptista Porta. In its original state it is nothing more than a darkened room, with an opening in the window shutter, in which is placed a convex lens, of one or more feet focal distance. If a sheet of white paper be held perpendicularly behind the lens, there will be painted on it a representation of all the objects to be seen from the window, whether at rest, or in motion. To exhibit this picture to several persons at once, or to enable a person to copy it, it is desirable that the image should be formed upon a horizontal table. This is done by a mirror, placed at an angle of 45° with the objects, which in the first form of the instrument represented below reflects the objects downwards, and in the second form, called the *box camera*, reflects them upwards.

A convenient form of the instrument is seen below, where the objects are reflected from the mirror A, downwards through the meniscus glass B, on the table C. The lower part of the instrument consists of a square box, one side of which is cut to admit the head and arms of the person who desires to trace with a pencil the objects delineated. It is best to fix the upper part which contains the lens, and to which the mirror is attached, on to a tube, that by turning it round the mirror may be directed to any part of the horizon.

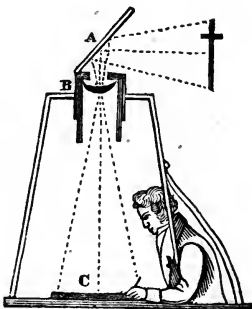

An apparatus like this is sometimes at-

tached to the top of a circular building, which is capable of holding several persons at once.

The *box camera* is constructed as follows: procure a box, about 14 inches long E, having another box sliding in it F; the inner box having but one end, and in the centre of that end a double convex lens of 10 inches focus A. The outer box contains a piece of looking glass B, fixed at an angle of 45° ; one part of the top also lifts up D, and its place is occupied by a piece of ground glass, with its ground side uppermost C. The rays of light passing the mirror, strike against the looking glass, and are by it reflected upwards, where they are intercepted by the ground glass, consequently upon this are seen the objects presented before A.

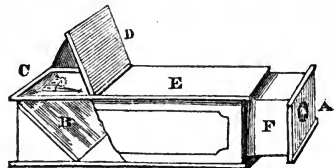

CAMELEON MINERAL. A name given to the manganisate of potass, because of its often-changing colors. When pure potass and black oxide of manganese are fused together in a crucible, a compound is formed; whose solution in water, at first green, passes spontaneous through the whole series of colored rays to the red. From this latter tint, the solution may be made to retrograde to the original green, by the addition of potass, or may be rendered altogether colorless, by the addition of chlorine, or sulphuric acid.

CAMEO. A name given to stones, shells, &c., when engraved, so as to show a bas-relief of busts, statues, &c., particularly if copies from antiques.

CAMERATED. The same as arched.

CAMES. In glazing, small slender rods of cast lead, about 12 or 14 inches long, to be drawn through a vice, in order to make turned lead; each such bar being called a *came*.

CAMLET, or CAMBLET. A light stuff, much used for female attire. It is made of long wool hard spun, sometimes mixed with cotton or linen yarn.

CAMP CEILING. A ceiling, formed of one or more planes, rising at an obtuse angle with the walls of the apartment, sometimes meeting in a point at the top, but more frequently inclosing a level ceiling in the middle between them.

CAMPEACHY WOOD. Logwood.

CAMPHOGEN, or CAMPENE. Oil of turpentine.

CAMPHOR. A volatile, concrete, strong-smelling oil, obtained from very many herbs and trees by distillation, particularly from the roots of different species of the laurel. It

swims on water, evaporates in a warm air, is soluble in alcohol, and in a very small degree in water. It burns with a very white light; and set fire to, when floating on water, it has the singular property of rotating during its inflammation, leaving no residuum. Its effluvia are very noxious to insects, for which reason camphor is mostly placed in cabinets of stuffed animals, furs, &c., to prevent the moths and other insects from attacking them.

CAMPHORATES. Salts formed of camphoric acid and numerous bases. They have a bitterish aromatic flavor, and are decomposed by the stronger acids. The alkaline and earthy camphorates are soluble. The metallic camphorates, except that of manganese, are insoluble.

CAMPHORIC ACID. When camphor is repeatedly distilled with nitric acid, it is converted into camphoric acid, and is in the form of plumose crystals, which are, like camphor itself, soluble very readily in alcohol, but with difficulty in water. It combines with the usual salifiable bases.

CAM WOOD. A wood employed in dyeing. It is brought from the Brazils.

CAMUS'S SIEVE. A contrivance, invented by Mr. Camus, for the moving of sieves.

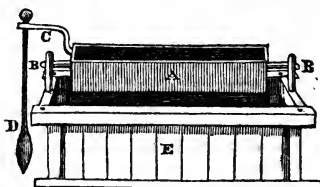

A is a sieve, which is capable of motion on the pivots B B; suspended to an arm C, attached to one of the ends of the sieve, or to one of the pivots, is a pendulum D. It is evident, that whatever motion is given to the pendulum, that motion will be communicated to the arm C, and by it to the sieve A. E is a box to receive the particles passing through the bottom of the sieve.

CANAL. An artificial channel for water, cut either for the purpose of transporting goods by boats, or sometimes to convey water to towns.

CANALS OF A COLUMN. The flutes of it.

CANAL OF THE IONIC VOLUTE. The spiral channel, or sinking on the face; which begins at the eye in a point, and expands in width till the whole circumvolutions are completed.

CANAL OF THE LARMIER. A channel cut underneath a soffit, coping stone, sill, &c., to prevent the rain which drips on it from passing to the walls of the building.

CANCELLI. Latticed windows, or those made with cross bars of wood or metal; they are mostly without glass.

CANCER. The crab; one of the twelve

signs of the zodiac, in which the sun enters on the 24th day of June, or our longest day.

CANCER, Tropic of. A small circle of the sphere, parallel to the equator, and at the distance of 23° 28' northward of it, bounding therefore the torrid zone to the north. It is so called because passing through the beginning of the constellation Aries, the point of the sun's greatest northern declination.

CANDELABRUM. A stand for a lamp.

CANDLE LAMP, is represented in the figure annexed. The tube A, which is called the candle, and which is formed and painted to resemble one, moves tightly up and down in the socket, or candlestick. This socket has at the upper end a pad, or piston of leather, fixed by a wire to the foot of the whole. The top of the candle is unscrewed, the candle drawn up to its full height; then filled with oil, the top furnished with a wick and lighted. As the candle may be pushed down within the socket whenever the lamp burns dimly, the oil may be constantly kept even with the top, so as to supply the wick. The overflow of oil is the great inconvenience by which this lamp is accompanied.

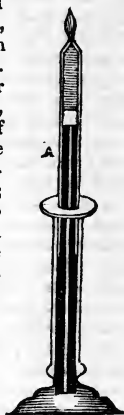

CANISTER SHOT. Tin canisters filled with small balls, which fired from cannon disperse themselves around, and are therefore most destructive in their effects.

CANNEL COAL. A species of coal, which contains a large proportion of bitumen; it burns with a bright flame, has a smooth surface when broken, and is much less friable than coal in general, on which account it is often turned into ornaments, snuff-boxes, &c.

CANNON, Electrical. (See *Air Pistol*.)

CANON. An old mathematical word for formula.

CANOPY. A magnificent covering for thrones, tribunals, altars, pulpits, &c. It also denotes the label, or projecting moulding, which surrounds the arch and heads of gothic niches, windows, and arches.

CANTED. When the angles are cut off a post, pier, beam, &c., it is called canted; when a turret is built of a polygonal form, it is said to be canted. Cant is also a term used by carpenters to designate those beams, timbers, &c., which are given to them the wrong way, so that they require to be turned end for end before they can be used. Among coopers, it signifies the two side pieces of wood which form the head of a cask.

CANTELIVERS. Trusses placed under the modillions in a frieze; also any projecting piece of iron, wood, &c., to support eaves, canopies, or cornices.

CANTHARIDIN. The active principle of cantharis. It was procured by Robiquet, in small brilliant micaceous plates.

CANTON'S PHOSPHORUS. Calcined phosphate of lime. To make it:—Calcine some common oyster-shells, let the purest part be pulverized and sifted, and then mix with it one-third in weight of flowers of sulphur; ram this mixture into a crucible; put it in the fire, and keep it red hot for an hour; afterwards let it cool, and keep for use the whitest parts. It becomes luminous when exposed to a succession of electric sparks, or any other strong light. It must be kept in a dry, stoppered phial.

CANTON'S METHOD OF MAKING MAGNETS. Take a poker and tongs, (or two bars of iron,) the larger and the older the better; and fixing the poker upright, hold to it with the left hand, near the top, by a silk thread, the bar of soft steel, of which the magnet is to be made, having its marked end downwards. Then grasping the tongs with the right hand, a little below their middle, and keeping them nearly in a vertical line, let the bar be rubbed with the lower end of the tongs, from the marked end of the bar to its upper end, about ten times on each side of it. By this means the bar will receive as much magnetism as will enable it to lift a small key at the marked end; and being suspended by its middle, or made to rest on a point, this end will turn to the *north*, and is called its *north* pole; the unmarked end being the *south* pole.

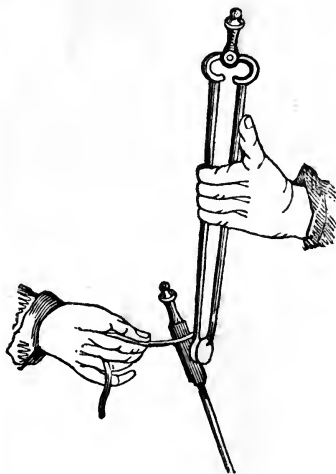

CANTONED BUILDING. A building whose angles are adorned with columns, pilasters, rustic quoins, or any thing that projects beyond the general surface of the walls.

CANTONED COLUMNS. Such as are placed at the angles of a square pier, &c., for supporting the springings of arches, or groins.

CANVAS. A hempen cloth, unbleached, and of various degrees of fineness; used principally to form the sails of a ship, and also by painters, and for other purposes.

CAOUTCHOUC, GUM ELASTIC, or INDIAN RUBBER. A milky juice which exudes from numerous trees, particularly those of the fig tribe. This concretes by exposure to the air, or to the heat of a fire. It is insoluble in water and in alcohol, but is soluble in pure ether, in hot naphtha, and the fixed oils. It is but little acted upon by the acids, or strongest alkalies, and not at all by any of the gases. It is used extensively in the manufacture of water-proof cloth, as a varnish for balloons, and by artists as a means of removing marks made by a black-lead pencil. Caoutchouc is almost the only concrete vegetable product which contains no oxygen; consisting, according to Dr. Ure, of 9 parts carbon to 1 hydrogen, being 3 atoms of the former to 2 of the latter.

CAOUTCHOUC, Solution of, may be made by cutting caoutchouc into small pieces, then soaking it in hot naphtha, made by the distillation of coal tar for some hours, when it swells to 30 times its original bulk; it is now to be pounded, and more naphtha added, and the heat being afterwards increased to boiling, the caoutchouc dissolves, forming a thick, clammy, transparent solution. A solution may also be made by treating it with spirits of turpentine in the same manner. Both solutions are tedious in drying, particularly the latter, though this is not so disagreeable in odour as that made by the coal naphtha.

CAOUTCHOUC VARNISH. To either of the above solutions add one-third its quantity of drying oil. This is said to be the varnish used for balloons; its elasticity renders such an application valuable to aeronautic machines, but the tediousness of its drying, and its long continued clamminess, make all caoutchouc varnishes unavailable for ordinary purposes.

CAOUTCHOUCINE. An inflammable liquor, procured from caoutchouc by distillation. It is one of the most remarkable substances; inasmuch as although the liquid itself is the lightest known, yet its vapour is heavier than that of any other substance. It is, when mixed with alcohol, a ready solvent for all the resins, even copal, and that without heat; it also mixes with oils, and is valuable when used along with painting oils, as it dries them quickly without doing injury to the most delicate colors.

CAPACITY OF A BODY. Its solidity, or content; but more commonly it denotes the hollow, or vacuity of bodies; thus we say, the capacity of a vessel, meaning the quantity it will contain.

CAPACITY FOR HEAT. (See *Caloric.*)

CAPILLARY ATTRACTION. (See *Attraction.*)

CAPILLARY TUBE. A hair is a tube, and hence tubes which are very small, or like hairs, are called capillary.

CAPILLARY TUBES and PLATES. Two philosophical instruments, so called, to show the effect of capillary attraction. The first consists of several small tubes of glass, open at both ends, and attached to a foot board, each of them having a bore, or cavity, of a size different from the rest; the largest being nearly half an inch diameter, the smaller, scarcely larger than a hair; when the lower ends are immersed in a basin of water, the water will rise in the various tubes, in proportion to their minuteness of cavity.

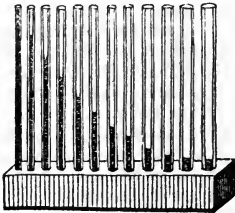

In the second instrument, two pieces of plate glass are fastened to a stand, in such a manner that they shall touch each other at one edge, and be separated at the other to the distance of a quarter of an inch, or more; when immersed in water, the fluid will rise between the plates, assuming the form of an hyperbolic curve as represented.

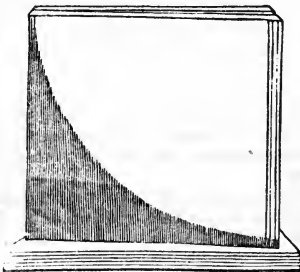

CAP, or CAPPING PIECE. The upper terminating portion of any thing, as the cap of a cupola; the cap of a printer's wooden press; the cap of a cannon is the piece of lead which shields the touch-hole from wet, &c.

CAPITAL. The projecting and ornamented part which rests upon the shaft of a column. The capital varies extremely in its details, according to the style of the building of which it forms a part. The classical styles have each

their appropriate capital. In the Doric and Tuscan it consists of mouldings only, as is seen under these words. In the Corinthian and Composite, the capital is enriched with sculptured leaves and tendrils, scrolls, &c. (See *Corinthian* and *Composite.*) In the Ionic, its enrichments consist of two scrolls, or volutes, as follows, more or less accompanied with mouldings, or beadings, around the neck of it.



In the Egyptian architecture, the capitals are much diversified, being some in es loaded with hieroglyphics; at others, formed of palm leaves folding over each other, or else of the lotus flower, and in numerous instances are sculptured into the representation of a female face. The following are examples of Egyptian capitals, from the Temple of Carnac.

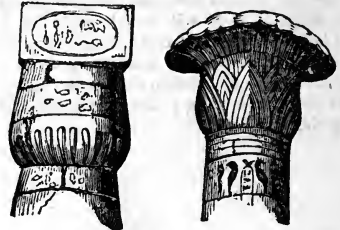

The capital of the most ancient Indian remains, as exemplified in the Caves of Ellora and Elephanta, is scarcely to be defined; often it consists of a huge elephant, supporting a short and thick pier; at others, of a block of stone, rudely sculptured into some grotesque form; while it sometimes appears as an object of considerable beauty. The following is from the Caves of Ellora:—



The Moorish capital is highly ornamental, not only in its general form, but in its elaborate ornaments, consisting of elegantly arranged cavities, of foliage, and of intertwining fret-work. The following is one of the capitals of that perfection of Moorish skill, the Alhambra of Grenada :—



The capitals of Gothic architecture are endlessly diversified; in the earliest style, and still, in ordinary edifices, it consists of plain mouldings running round the ends of the pillars.



In the Anglo-Norman style rude attempts at ornaments were made, foliage began to show itself, and what is called the *cushion* capital became prevalent. Capitals of this name and period are represented below.

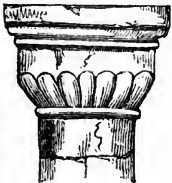

As Gothic architecture progressed through the more ornamental styles of the lancet arched, the decorated, and the perpendicular, the capital was variously enriched with leaves, tendrils, grotesque heads, and other elaborately-carved ornaments. The following

beautiful capital is taken from York Cathedral :—

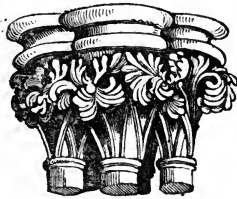

CAPITAL, Angular. (See *Angular Capital*.)
CAPITAL OF A LANTERN. The covering by which it is terminated, either in a bell-shape, a spire, or other form.

CAPITAL OF A TRIGLYPH. The projecting band which surmounts the face of a triglyph. In the Grecian Doric, its projection is very trifling, and it is confined to the front face. In the Roman Doric, it is more prominent, and is returned around the flanks of the triglyph, while a moulding, similar to it, extends along the top of the mutules, from one triglyph to another.

CAPNOMOR. A colorless transparent liquid, of a pungent and rather agreeable odour, which occurs in the oil of tar. It is insoluble in water and the alkalies; but soluble in alcohol, and in ether.

CAPRIC ACID. An acid produced along with caproic acid and buturic acid from butter. Neither acid has yet been applied to any purpose in the arts or in medicine.

CAPROIC ACID. (See *Capric*.)

CAPRICORN. The goat. A southern constellation, and the tenth sign of the zodiac. It is denoted by the character ω , being intended for the representation of the goat's horns. When the sun enters this sign it is the winter solstice, or the shortest day.

CAPRICORN, Tropic of. An imaginary line, bounding the torrid zone to the south, and passing through the first point of Capricorn, which is the point also of the sun's greatest southern declination, being $23\frac{1}{2}^{\circ}$ nearly.

CAPSICIN. An alkaline principle, lately discovered in cayenne pepper. Its properties have not yet been ascertained.

CAPSTAN. A machine upon the principle of the lever, employed principally in large vessels, for heaving up, or weighing the anchor. It consists of a drum, or barrel, revolving upon an upright spindle, and having holes cut in the upper part, or drum head, to receive the ends of a series of horizontal levers, called capstan bars. The capstan is superior to the windlass in point of expedition, owing to the circumstance of the latter requiring the levers to be shifted into fresh

holes, four times in each revolution ; though in the windlass man's power is exerted with much greater effect.

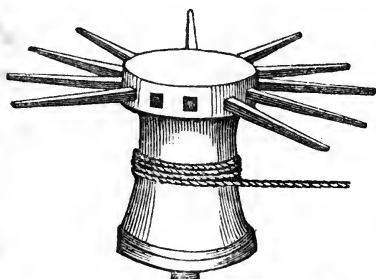

CAPUT MORTUUM. The burnt residue left in a still, when a substance has been subjected to destructive distillation.

CARAT. An imaginary weight to indicate the proportion of a precious metal in any mass. The mass being supposed to be divided into 24 equal parts, a carat is one of these parts ; and the metal is said to be so many carats fine, or to have so many carats of gold, &c., in it. Pure gold is therefore 24 carats fine, if alloyed with half copper it will be 12 carats fine, and so on.

CARBON. One of those chemical substances supposed to be simple or uncombined. In its crystalline and perfectly pure state it is known as the diamond. In its uncrystalline form it constitutes *charcoal*, which may be called wood carbon, and which is the residue of wood which has been burnt without contact with the air. Animal charcoal, or ivory black, is carbon produced by burning bones, and other parts of animals, in a similar manner. Lamp black is the carbon given off by lamps, which but imperfectly decompose the fatty material with which they are fed. Soot is the carbon which escapes from smoky fires ; and coke the carbon procured by the partial burning of coals. Each of these kinds has its own peculiarity, and except common charcoal, is impregnated with either earthy or oily particles. Charcoal is infusible, incombustible without air, but the most combustible substance in nature when air is admitted. It forms a part of all animal and vegetable matters. It is black, inodorous, insipid, brittle, an excellent conductor of electricity, but a bad conductor of heat ; it remains uninjured by time, or the effects of air and moisture. It combines with most of the gases ; united with oxygen it forms carbonic oxyde, or carbonic acid. It also combines with most of the simple substances, forming carburets. Charcoal is valuable as a fuel, which gives an intense heat without smoke ; as an ingredient in gunpowder ; as a substance which rapidly absorbs ill odours, and

considerably retards the putrefaction of animal substances ; as an ingredient in indestructible writing inks ; by artists as a crayon, and numerous other purposes.

CARBONATED WATER. Water holding carbonic acid gas in solution. (See *Aerated Waters and Soda Water*.)

CARBONATES. Salts formed by the combination of carbonic acid with alkalis, earths, and certain metallic oxydes. The carbonates used in the arts are chiefly the following :—

CARBONATE OF AMMONIA. A salt, called in modern chemistry the sesquicarbonate of ammonia, to indicate its composition to consist of 1 and a $\frac{1}{2}$ atoms of carbonic acid to 1 of ammonia. This salt is the common *smelling salts* of commerce. It is much employed in medicine, in chemical analysis, and by the pastrycooks instead of yeast ; by exposure to the air, the ammonia exhales, and it becomes the scentless bicarbonate.

CARBONATE OF COPPER. Malachite ; a beautiful green mineral, used in brooches, for seals, &c.

CARBONATE OF LEAD. White lead ; used as a white coloring matter by the painter. It is made by subjecting plates of lead to the fumes of vinegar, and afterwards decomposing the acetate of lead thus formed by a carbonate.

CARBONATE OF LIME. Chalk, limestone, &c. In a crystalline form it is called calcareous spar, (which see,) and Iceland spar, or double refractive spar.

CARBONATE OF MAGNESIA. Much used in medicine as an absorbent, to correct acidity, &c.

CARBONATE OF POTASS. Better known as wood ashes, potash, and pearlash, according to its state of purity or impurity. It is made by burning wood and terrestrial vegetables, dissolving the potass out of the ashes, and afterwards evaporating the liquor to obtain the potass held in solution. It is also made from *tartar* in the same manner ; in that case the residue being called *salt of tartar*. Pearlash is very soluble in water, and exposed to the air it deliquesces, forming what is called *oil of tartar per deliquium*.

CARBONATE OF SODA, obtained in the same manner as the carbonate of potass, but using marine vegetables, or by decomposing sea salt. It is, like the last, extensively used in the arts, in the soap and glass manufactures, and in medicine.

CARBONIC ACID, CARBONIC ACID GAS, FIXED AIR, AERIAL ACID, CHOKE DAMP, &c. A union of oxygen and carbon, in the proportion of 1 atom of the latter to 2 of oxygen. Its natural state is that of a gas. It combines with most of the alkalis, metallic oxydes, earths, &c., forming carbonates. Its specific gravity is half as much again as water, or 1.5245. It therefore sinks in the air. It exists abundantly in nature, in chalk,

marble, limestone, &c., each grain of which will yield 1 cubic inch of gas. It frequently occurs in mines, pits, and wells. It is yielded in abundance by bodies passing through the vinous fermentation, and is absorbable by water. It cannot be inhaled for a single minute without destroying life. Carbonic acid gas may be condensed into a liquid state by a pressure of 40 atmospheres, and this liquid may then be solidified by the cold produced by its own spontaneous evaporation.

CARBONIC OXYDE. Gaseous oxyde of carbon. A gas obtained by subjecting carbonic acid gas to the action of substances that abstract a portion of oxygen. It may be produced by heating in an iron retort, a mixture of chalk and charcoal, or equal weights of chalk, and iron or zinc filings. It is lighter than atmospheric air, has no taste and little odour, extinguishes flame, and burns with a blue light when heated and exposed to atmospheric air. It does not affect vegetable colors, occasions no precipitate with lime water, and is very sparingly absorbed by water.

CARBONOUS ACID. A name given to oxalic acid by Döbereiner.

CARBOY. A large green glass bottle, of from 4 to 10 gallons; used for holding the oil of turpentine, the powerful acids, and other dangerous fluids.

CARBAZOTATES. Salts formed of bases and carbazotic acid.

CARBAZOTIC ACID, is procured by dissolving bits of indigo in 8 or 10 times their weight of nitric acid, moderately strong, and boiling the solution till it ceases to fume. On cooling, the acid crystallizes in semi-transparent yellow crystals. It is the same as aleötic acid, and is soluble in cold and hot water, alcohol, &c.

CARBUNCLE. A precious stone, the color of which is a dark red, with an admixture of scarlet. It is rather rare; is found only in the East Indies, adhering to a heavy and ferruginous stone of the emery kind.

CARBURETS. Combinations of carbon with any of the simple substances.

CARBURET OF SULPHUR, called also **SULPHURET OF CARBON** and **ALCOHOL OF SULPHUR.** A limpid volatile liquid, of a penetrating fetid smell, and an acrid burning taste. Its specific gravity is 1.265, and its boiling point about 112° Fahr. It evaporates so readily, and absorbs so much heat in the vaporous state, that if a tube containing quicksilver, surrounded with lint dipped in it, be suspended in the receiver of an air pump, and the air exhausted, the quicksilver will be frozen. It consists of 15.8 carbon and 84.2 sulphur, in 100 parts.

CARBURETTED HYDROGEN. A compound of carbon and hydrogen, of which there are several species—some gaseous, others liquid; such as *Oil Gas*, *Coal Gas*, *Olephant Gas*,

Naphtha, *Caoutchoucine*, &c., (which see.)

CARBURETTED HYDROGEN GAS, is of two kinds; one procured by art, called heavy carburetted hydrogen, such as coal and oil gas, and which burns with a pure white flame; and light carburetted hydrogen gas, procurable from, and emitted by the water of stagnant pools and ditches, and which is so frequently to be dreaded in coal mines, under the name of the fire damp. It burns with a yellowish light, and is a sub-carburet of hydrogen.

CARCASE. The work of a house before it is either lathed or plastered, or the floors laid. As the whole house thus unfinished is called a carcase, so certain portions of it, when in like manner incomplete, are also said to be carcases; thus, carcase flooring, carcase roof, &c.

CARDINAL POINTS. The four chief points of the compass, east, west, north, and south. These being the points from which all other names are taken.

CARDINAL SIGNS. Those at the four quarters of the year; that is, the signs Aries, Libra, Cancer, and Capricorn, or the two equinoxes and the two solstices; answering to the beginning of spring, summer, autumn, and winter.

CARDIOIDE CURVE. A curve so named from its resemblance to a heart. It is to be made as follows:—

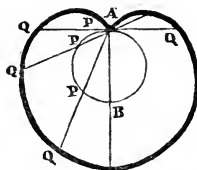

Through one extremity A of the diameter AB of the circle APB, draw a number of lines APQ, cutting the circle in P, &c; and upon these set off PQ, equal to the diameter AB. Then the curve passing through all the points Q is termed the cardioid. To form the upper part of the curve, continue any of the lines beyond A until the whole length of each be equal to double the diameter of the circle APB.

CARDS. Brushes made of long bent wires; used in the cotton and woollen manufacture, to straighten the fibres drawn through them; an operation of the utmost importance previous to spinning.

CARMINE. A bright crimson pigment, obtained by precipitating the coloring matter of cochineal. One preparation is as follows;—Pulverize 4 ounces of cochineal, and add to it 4 quarts of rain water, previously boiled; boil the whole for six minutes, adding during the boiling 2 drams of pulverized

crystals of tartar. Then add 8 scruples of Roman alum in powder; set it aside, and as soon as the gross powder has subsided, and the decoction become clear, decant it into long glass vessels, and the powder which falls to the bottom is carmine. It is afterwards to be dried at a slow fire.

CAROLYTIC COLUMNS. Such columns as have leaves and branches winding spirally round them, or disposed in the form of festoons and crowns. They were used by the ancients in supporting statues, and are now frequent in theatres and such places.

CAROMEL. The smell exhaled by sugar when calcined.

CARPENTRY. The art of building or constructing the frame work and unornamental parts of churches, houses, and other edifices. Joinery is the art of finishing these with smooth and ornamental work. The two arts are mostly united in the same persons.

CARRARA MARBLE. A fine kind of marble; the quarries of which are on the south side of the Appenines, at Carrara, a town and principality of Italy. It is of various colors; the best is of a fine white, and when broken resembles the whitest loaf sugar.

CARRIAGE OF A WOODEN STAIR, is the frame of timber work which supports the steps.

CARTESIAN DEVILS. A philosophical instrument so called. It consists of one or more glass figures, floating in water. The figures are hollow, and have each a minute hole in the foot. They are to be partly filled with water, until they will just float; thus balanced, they are to be put in a long glass vessel, also filled nearly to the top with water, and an Indian rubber cover tied air-tight on the top, over the whole. The figures it will be observed contain partly air and partly water; upon pressing the Indian rubber strongly, it compresses the air within the vessel. The increased pressure or density given to this, is communicated through the water to the globe of air within the figures. As the air within the figures is compressed, it occupies less room than before, and consequently an extra quantity of water enters them, and they becoming heavier sink to the bottom, while the removal of the hand from the top, by relieving the compression, restores the first condition, and they rise again.

CARTESIAN PHILOSOPHY, or **CARTESIANISM;** is founded on two principles; one physical, the other metaphysical, Des Cartes states, "that nothing exists but substances,

and that substance is of two kinds; one kind that thinks—another kind that does not think; but that has extension or dimensions; actual thought and actual extension then form the essence of substance. The essence of matter being thus fixed in extension, Des Cartes concludes that there is no vacuum, nor any possibility of it, in nature, but that the universe is absolutely full, mere space being quite excluded.

CARTESIAN VORTICES. Des Cartes among other hypotheses maintained, that at the creation of all things the universe was divided into innumerable square portions, each of which contains elements of various degrees of density; that the Creator put each portion into a double motion, one around its own axis, the other around a common centre. In consequence of this rotatory motion, the square portions became rounded, the lighter elements were collected together, as a sun in the centre, the more gross as an atmosphere throughout the whole system, and the grossest particles of all formed planets, and other opaque bodies. This system of creation is usually known by the name of the vortices of Des Cartes.

CARTHAMINE. CARTHAMIC ACID. The red coloring matter of carthamus tinctorius, or safflower, which Döbereiner considered a peculiar acid—giving it the above name.

CARTHAMUS, or SAFFLOWER. An annual plant, cultivated in Spain, Egypt, and the Levant. It is used in dyeing; yielding two coloring matters, one of a yellow color, which is soluble in water; the other, a fine red color, which is soluble in alcohol, and alkaline solutions. The latter is that which is most useful: it is the color called rouge, as used by ladies to heighten their complexion, and is also the ingredient which forms the coloring matter of pink saucers.

CARTOUCH. In architecture, a shield or carved ornament, various in form, whose use is to receive an inscription, or motto. Its form is frequently that of a scroll of paper, somewhat unfolded, as used in the corners of maps, to indicate the name of the country or estate which may be represented.

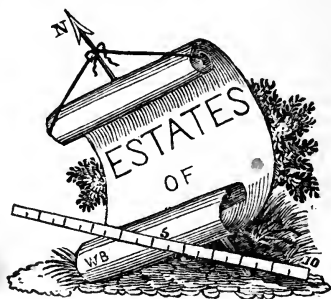
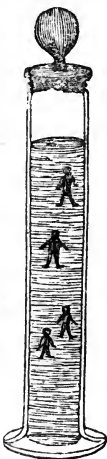

On a building it more commonly is in the form of a panel, or shield. The modillions, or blocks, introduced into the cornices of apartments are also called cartouches. The following is a panelled cartouch of the time of Elizabeth:—

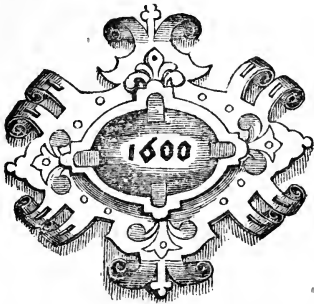

CARTOON. A drawing or painting upon large paper, usually made as a pattern for painting in fresco, tapestry, Mosaic, &c. In either case, the artist cannot trace his entire outline, as on canvas; therefore he joins several sheets of paper together, draws his full design upon them, then pricks through the outlines with a sharp point, and then each part is transferred to the work as wanted. Thus were traced the splendid cartoons of Raphaelle, preserved at Hampton Court.

CARTWRIGHT'S STEAM ENGINE. An engine moved by steam, the superiority of which over the engines previously in use, consisted in compactness of parts; and still more particularly in obliging the steam to be condensed to pass through an air jacket, having cold water on each side of it. The following is the general structure:—

B is a piston, working in the steam cylinder A; its rod is continued downwards, and works the second piston D in the cylinder C. The steam cylinder is connected by a pipe G to the condenser F, which condenser consists of two concentric circular vessels. The water of condensation falls into the pipe E. To the bottom of the cylinder C a pipe M is carried into a box N, having a float ball O, which opens and shuts the valve P, communicating with the atmosphere; a pipe Q is also fitted to the box. There is a valve at I, opening upwards; and another at N, also opening upwards. The pipe N conveys steam from the boiler into the cylinder, which may be shut by the fall of the clack R. K is a valve made in the piston B. In the figure the pistons B and D are shown descending. When the piston B reaches the bottom of the cylinder A, the tail of the valve K being pressed upwards, opens the valve, and forms a communication between the upper side of the piston and the condenser; at the same mo-

ment the valve R is pressed into its seat by the descent of the cross arm on the piston,

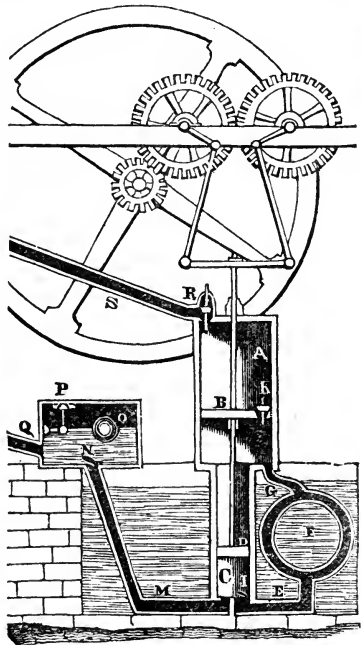

which prevents the further admission of steam from the boiler. This allows the piston to be drawn up to the top of the cylinder by the momentum of the fly wheel. The piston D is also drawn up to the top of C, and the valve I is raised by the condensed water and air, which have accumulated in G, and in the condenser F. At the moment when the piston has reached the top of the cylinder, the valve K is pressed into its place, by the pin or tail striking the cylinder cover; and at the same time the piston B striking the tail of the valve R opens it, and letting in the steam, the action goes on as at first. By the descent of the piston D, the water and air which were under it in the cylinder C being prevented from returning into the condenser by the valve I, are driven up the pipe M into the box N, and are conveyed into the boiler by the pipe O. The air rises above the water in N, and when by its accumulation its pressure is increased, it passes the float O downwards; this opens the valve P, and allows it to escape into the atmosphere. This simple machine is well adapted as a prime mover on a small scale; and it is to be remarked, that this is the first engine which was furnished with a *metallic* piston.

CARTWRIGHT'S ROTATORY STEAM ENGINE. Of this engine it is only necessary to

notice the moving power, the more especially as it has never been employed to any extent.

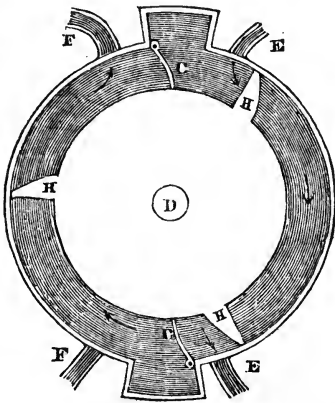

The axis D has an unequal number of pistons H H H, (not less than three,) upon it, so disposed that no two shall be opposite. In the cylinder in which the axis revolves are two valves, at opposite sides of the cylinder C.C.; on the side of each valve is a pipe for the admission of steam E, and another communicating with the condenser F. It is obvious that the number of pistons and valves not corresponding, some one or other of them will always be in action on one side or the other of the cylinder. The engine will consequently have no tendency to stop; and therefore no fly wheel need be attached to it.

CASCABEL. The round ball, or knob of metal, behind the breech of a cannon; it serves as a handle to elevate, or direct, the piece, and likewise to fasten it.

CASE. In printing, a large oblong frame, placed aslope, divided into several little square compartments, in each of which are kept a quantity of types, or letters, of the same kind, whence the compositor takes them as they are required for the work he has in hand.

CASE OF A DOOR. The frame in which a door is hung, and which is exactly filled up by the door when closed.

CASE BAYS. The joists framed between a pair of girders; they should not exceed 10 feet in length.

CASED. In masonry, a term indicating that the outside of a building is covered with some material better than that which forms the main part of it.

CASED SASH FRAMES have their vertical sides hollow, to conceal the weights for hanging the sashes.

CASE HARDENING is a process by which iron articles have their surfaces rapidly con-

verted into steel; thus they are, at the same time, cheap as iron, and retain their polish like steel goods. The process is usually applied to fenders, fire-irons, &c. There are many ways of case hardening iron goods, but the following is the easiest, quickest, and most convenient:—Make the iron red hot, and then sprinkle it over with the ferrocyanate (prussiate) of potass, and when the salt is apparently dissipated quench the iron in cold water.

CASE SHOT. (See *Canister Shot*.)

CASEIC ACID. An acid procured by M. Proust from old cheese.

CASEOUS OXIDE. The name given by Proust to aposepedine.

CASEUM. The curd of milk. When caseum is dried, and afterwards mixed with a small quantity of the carbonate of soda, it has been used instead of milk on sea voyages, and with much success.

CASEMATES. Vaulted apartments of masonry made in the bastions of fortifications; also a hollow cylindrical moulding, the section of which is from one-sixth to one-fourth of a circle.



CASEMENT. One of the compartments between the mullions of a window; a frame inclosing part of the glazing of a window, with hinges to open and shut.

CASSEGRAINIAN TELESCOPE. An astronomical reflective telescope, which acts by receiving the objects on a concave perforated speculum, whence they are reflected on to a small convex speculum, situated on the axis of the instrument, and finally are reflected by this to the eye glass. The only difference, therefore, between the Cassegrainian and the Gregorian telescopes is in the small mirror of the former being convex, instead of concave. The advantage of which is, that the present telescope is shorter than the Gregorian by more than twice the focal length of the small speculum; and it is generally admitted that it gives more light, and a distincter image, in consequence of the convex speculum correcting the aberration of the concave one.

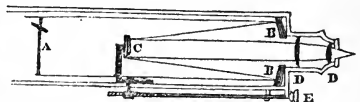

A is the object. B B the large speculum. C the small convex speculum. D the eye glasses. E a tangent screw, connected with the small speculum to regulate the focus of it.

CASK. Any round vessel of capacity for holding liquid or dry goods: it differs from a tub in having two ends or heads, while a tub has but one.

CASSIANA. A bitter principle, found in the root of cassia fistula by M. Caventou.

CASSIUS. PURPLE PRECIPITATE OF. Gold thrown down from its solution in aqua regia by metallic tin; it is of a splendid blue color, much used by painters in enamel.

CAST. Among plumbers a small brazen funnel, through which molten lead is poured in the making of cast lead in pipes, it being placed at the mouth of the mould.

CASTELLATED. Built after the manner of a castle.

CASTING. The art of taking the impression of any surface, whether plain or ornamental, by pouring a liquid matter on that surface.

CASTING, or WARPING, said of any thing which has become twisted by unequal pressure, heat, moisture, &c.

CASTING OF DRAPERIES. In painting, the proper distribution of the quantity and folds of curtains, garments, &c., in painting an sculpture, so that they may appear the result of nature rather than of art.

CATACOUSTIC. The science of reflected sounds, or echoes.

CATACAUSTIC CURVES. Curves formed by reflection from a circular concave surface. Let A B, A C, A D, be rays of light reflected from the curve B C D in the lines B I, C E, D F. The angles of incidence being equal to the angles of reflection. Then the curve E F G will be a caustic formed by reflection, or a catacaustic.

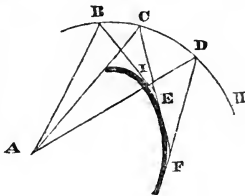

A perfect curve of this nature may be seen on the surface of milk in a round smooth basin, when it is exposed to the sun's light.

CATACOMBS. Subterranean vaults for burial. The catacombs of Egypt are much celebrated; the crypts under many of our old churches are of this nature.

CATADIOPTICAL. Reflecting.

CATADROME. An instrument used in building, for raising or letting down great weights.

CATCH. Various contrivances of a mechanical nature, to take hold of, or connect one thing with another; it may be on the principle of a hook, latch, or otherwise, as most convenient.

CATCH-WATER DRAINS. Drains, or channels, cut in a slanting direction across and down embankments, therefore catching and carrying off the water which falls upon them.

CATECHU, or JAPAN EARTH. An extract prepared in India from the juice of the *mimosa catechu*. It is a dry pulverable substance, outwardly of a reddish color, and internally of a shining dark brown. It contains a greater portion of tannin than any other vegetable, and what is very remarkable, no gallic acid.

CATENARIAN CURVE. The curved line described by a chain, cord, or other flexible body, when hanging freely and unloaded from any two fixed points, whether they be horizontal or not. This form of curve is considered superior to any other for inverted arches, such as are requisite in chain bridges, as there is no strain, except the weight of the materials, and consequently the abutments are less affected by lateral pressure, than in arches of any other curvature.

CATGUT. A name given to strings formed out of the intestines of animals, particularly those of the sheep. Catguts are used for whip-cord, cords for hatter's bows, for clocks, lathe bands, strings for musical instruments, &c. For the latter purpose, the strings made in Italy are far superior to those of English manufacture, the reason of which is supposed to be the different breed, or perhaps condition, of the Italian sheep, when compared with ours.

CATHARTIN. An alkaline substance, found by M. Lassaigne and Fenneule, in the pods and leaves of senna. It is soluble in hot and cold water, and alcohol, not in ether; is nauseously bitter; of a peculiar odour; and a yellowish brown color.

CATHELECTRODE. The negative pole of a galvanic battery.

CATHERINE-WHEEL WINDOW. (See *Rose Window*.)

CATHETUS. An old mathematical word for perpendicular.

CATHODE. The negative pole of a galvanic battery.

CATOPTRIC. Any thing which acts by reflecting the rays of light, as a catoptric telescope, a catoptric dial, &c.

CATOPTRICS. The science of reflected vision, or that branch of optics which illustrates the laws and properties of light, reflected from mirrors or specula.

CATOPTRIC CISTULA. Boxes, of various shapes, lined as to their sides with looking glass. The rays of light falling from an object upon either of these sides, is reflected from the rest, so that the object appears indefinitely multiplied. The boxes may have any number of sides, or these set to any angle, according to the effect required to be produced.

The following represents one of these instruments. It is formed from a six-sided box ; the top of it is left open, or only covered

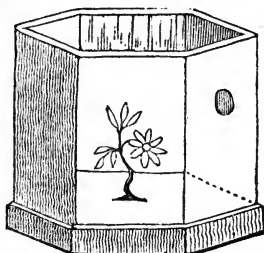

with a transparent medium, that light may freely penetrate. The sides of the box are lined with looking glass, and a hole is made through one side, to look through. A flower, or other object, may be placed in a small hole in the centre of the bottom, so as to reach half up the box ; this being illuminated, upon looking through the hole, the flower, owing to the continued reflection of the light from it, from one side to another, will seem as if it were hundreds of flowers collected in the box. A mouse put into the box will produce a still more astonishing optical deception.

CATOPTRIC, or REFLECTIVE DIAL, is a kind of dial which shows the hours by means of a piece of looking glass, adjusted to reflect the solar rays upwards to the ceiling of a room, on which the hour lines are delineated.

CATOPTRIC TELESCOPES. (See *Reflective Telescopes*.)

CAT'S EYE A mineral, brought from Ceylon, of various shades of grey, green, brown, and red colors, and remarkable for a particular play of light, proceeding from interposed white fibres. From this circumstance the name is derived ; it is often set as a precious stone.

CAT'S HEAD. A particular architectural ornament used in the early English and Norman style of building ; it varies but little from the beak-head ornament, and is used in edifices of the same age and character, and in similar situations, such as in the mouldings around door-ways and arcades.



CAVALLO'S AIR PISTOL. (See *Air Pistol*.)

CAVALLO'S ATMOSPHERIC ELECTROSCOPE. It consists of a common jointed sliding rod, without the smallest joint ; from

the extremity proceeds a glass tube, covered with sealing wax, and terminated by a cork ball. From this cork ball are suspended two pith balls, tied to filaments of linen thread ; also a string runs loosely along the rod, and by means of a common pin is attached to the cork ball. To use the instrument, hold it from a house, or otherwise, so as to project into the air as clear as possible from obstacles. After a minute or two pull the string, which will insulate the electrometer, and the divergence of the pith balls of it will indicate the electric state of the air around.

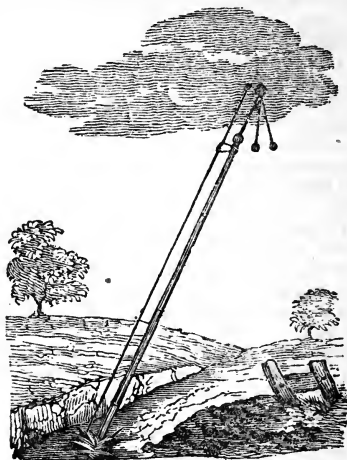

CAVALLO'S BOTTLE ELECTROSCOPE, is formed by two silver wires, each carrying at one of its ends a little ball made of pith. The other ends of the wires being suspended from a cork, which is rather long and tapering at both ends, so as to fit either way into the mouth of a varnished glass tube, serving both as a handle to the instrument when in use, and as a case for it when carried in the pocket. When it is to be employed as an electroscope, the cork is so placed, that the wires hang out of the tube, and will indicate by their divergence any electricity that may be communicated to them. When not in use, reversing the cork closes up the instrument, and renders it more portable.

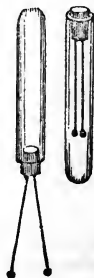

CAVALLO'S RAIN ELECTROSCOPE, varies considerably from the above ; it is represented in the cut. A is a strong glass tube, about 2 feet and a $\frac{1}{2}$ long, having a tin funnel cemented to its extremity, which funnel defends part of the tube from the rain. The outside surface of the tube is wholly covered

with sealing wax; C is a piece of cane, round which brass wires are twisted in different directions, so as to catch the rain easily, and at the same time to make no resistance to the wind. The cane is fixed into the tube, and a piece of wire proceeding from it, goes through the tube, and is terminated by a ring, upon which a pair of pith balls are suspended. This instrument is suspended by the side of a window frame, with the funnel projecting outwards, while the pith balls are preserved dry within.



CAVALLO'S SELF-CHARGING LEYDEN JAR. Procure a glass tube of about an inch internal diameter, and 18 inches long; coat one end of this tube, about half its length within and without, with tin foil, the tin foil however not reaching quite to the end by about 2 inches. Put in a cork, and a wire through the cork at the coated end. Then hold the tube in one hand by the glass end of it, and rub up and down on the coated end with a piece of flannel, or silk, it will thereby become charged; observing, however, to leave off the rubbing every now and then to touch the ball at the end of the wire. This will charge the tube; the discharge is made in the usual way.

CAVAZION, or CAVASION. An excavation made in the ground for the foundation of a building.

CAVETTO. A small hollow moulding, comprising a quarter of a circle; also the hollow, whatever its depth, between the tori on the base of the Corinthian and Composite columns. The workmen call it *mouth* when the upper part projects forward, and *throat* when the lower part is most prominent.

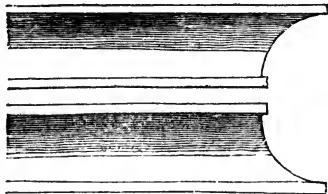

CAULICOLI. The smaller central volutes of the Corinthian capital.

CAULKING. A term applied in ship building to the driving of a quantity of oakum, saturated with tar, into the seams between the planks of ships, which is effected with a mallet and blunt chisel. The term is applied to many operations similar to the above, as by

engineers in stopping the joints of boilers with iron cement. Coopers also stop up in like manner the minor leakages between the staves and head pieces of new casks, with brown paper. This they call *chincing*, and the blunt chisel used a *chincing iron*.

CAUSTIC. In chemistry, applied to those bodies which rapidly corrode animal substances, particularly certain salts, which become thus decomposed, one of their constituents acting very powerfully upon the skin. Also alkalis are extremely caustic, when deprived of carbonic acid, either by heat, or by the addition of quick lime.

CAUSTIC CURVES. (See *Catacaustic*.)

CAUSTIC, Lunar. The nitrate of silver, fused and formed into small cylindrical pieces in a mould.

CAWK. Sulphate of barytes.

CAVENDISH'S EUDIOMETER. An instrument for the detonation of mixed gases. It is made and used as follows:—

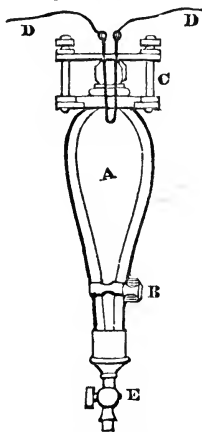

A is a strong glass vessel, with a glass stop-cock B, with a second stop-cock and brass collar at E, and with a ground stopper, firmly secured by the brass strap and screws at C. Through this stopper the platinum wires D D pass, and project a little into the cavity of A. The vessel A, previously exhausted of air, is screwed by E on to a receiver of the mixed gases, over a pneumatic trough. Upon opening the cocks B and E the gas will ascend, and fill A, where after having carefully closed the stop-cocks, it may be inflamed by an electric spark passed through the platinum wires.

CAVENDISH'S MAXIMUM and MINIMUM THERMOMETERS. The former of these instruments is represented in figure 1; it consists of a cylindrical bulb A, and a stem B, terminating in an open capillary orifice, covered by a glass ball or cap C, which com-

pletely closes it. The bulb and part of the stem are filled with mercury, the rise and fall of which indicate the temperature in the usual way. Above the mercury a portion of spirit of wine is introduced, sufficient to fill the rest of the tube, and a small part of the cap. When the mercury rises, it drives the spirit before it into the cap C, from which it cannot return while the instrument remains erect, and the deficiency of spirit in the tube on the subsiding of the mercury will show the maximum rise of the thermometer. No. 2 shows another form of the instrument, which being filled with spirit at the larger end, obviates the inconvenience of having so heavy a bulb of mercury. No. 3 is the minimum thermometer. Its bulb A, three-fourths of the ball E, and part of the leg B, are filled with spirits of wine. From B to C is filled with mercury, and so also is about one-fourth of the ball E. Above C is a little spirits of wine, and the tube is hermetically sealed at the upper end. The mercury will, by the addition of a scale, indicate the temperature in the usual way, but when cold contracts the spirits of wine in the bulb A, the mercury will rise in the short tube B, and fall into the ball E, from which it cannot get back again into B. The quantity of mercury lost, indicated in the short leg, will show the minimum temperature. Fig. 4 is another form of the instrument, which is rather more convenient than the former.

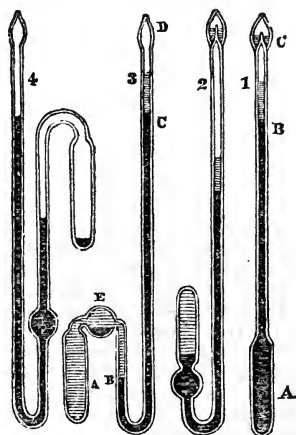

CEILING. The inside of a roof, or top of an apartment, more especially the stone work, and the lath and plaster which covers the under-side of rafters, or of flooring joists. Ceilings in ordinary domestic buildings, of the present time, are usually quite flat, and without ornament, except perhaps a slight cornice around the edges; but in the age of

Elizabeth, and previously, although of plaster, they were made highly ornamental, as may be seen from the following example:—



In public edifices of the more ornamental character, the ceilings are often divided into rectangular compartments, or sunk panels, with mouldings, formed of three fillets between them, and a rosette in the centre of each. This kind of ceiling, particularly when it applies to octagonal-shaped panels, with squares in the interstices, is called *coffering*, and the recessed parts *coffers*; and is used not merely in flat, but in arched and cylindrical vaults. The borders of the coffering are often terminated by belts, charged with foliage, or with guilloches. A ceiling may be either plain, coved, domed, or vaulted; if made on the under-side of the rafters, it is said to be *camp-ceiled*, or *tent-ceiled*. The under-side of arches and recesses is called their *intrados*, or *soffit*, and not ceiling; the latter word being confined to inclosed, or to extended spaces.

CEILING. In carpentry, the wood-work for supporting the lath and plaster at the top of a room.

CEILING FLOOR. The joisting and ceiling supported by the beams of the roof.

CELESTINE. Native sulphate of strontites.

CELESTIAL. Anything relating to the heavens, as a celestial globe is one upon which the constellations are depicted.

CELL, in carpentry. (See *Sill*.)

CELLA. The inclosed space within the walls of an ancient temple.

CELLS. The hollow spaces between the ribs of a groined roof.

CELSIUS'S THERMOMETER. (See *Centigrade*.)

CEMENTS. Substances employed to join others in close adhesion which would not otherwise unite. For this purpose, they are employed in a semifluid or pasty state, so as to be brought into closer contact with the opposite surfaces, and becoming solid as the moisture exhales, or in other cases as they become cold, the whole forms as it were one

mass. Wax, glue, sealing wax, rosin, mortar, plaster of Paris, various gums, &c., are all cements. (Various receipts will be found under the heads of *Cheese, Electrical, Armenian, Glass, Iron, Lapidary, Water, Roman, Rice, Vancouver's, &c.*) besides the following:—

CEMENT for steam and hydraulic works, such as the flanches of boilers, pumps, &c, Boiled linseed oil, litharge, red and white lead, mixed together till of a proper consistence and spread upon both sides of flannel, rag, paper, felt, &c., and screwed up tight by the bolts of the joint. The respective quantities of the litharge and leads are of little consequence. For copper boilers, &c., a cement of powdered quicklime and bullock's blood is generally used.

CEMENTATION. A chemical process, which consists in surrounding a body in the solid state, with some powder of another body, which is more combustible, or which unites with it without the whole contents becoming fused. Thus, iron is converted into steel by cementation, by being surrounded with charcoal powder, which, during combustion, yields its carbon to the iron.

CENOTAPH. An honorary monument, erected to the memory of the dead when the funeral rites have been performed in some other place.

CENTER. (See *Centre.*)

CENTERING OF LENSES. (See *Lenses.*)

CENTESM. The hundredth part of a thing.

CENTIGRADE THERMOMETER. A thermometer, known in the north of Europe, where it is most used, as the thermometer of Celsius, that philosopher having suggested that the scale of this instrument ought to be divided into 100 parts or degrees, reckoning from the height at which the mercury stands when the instrument is placed in freezing and in boiling water; the freezing point being indicated by 0, and the boiling point by 100°. This division of the scale has two inconveniences; one, that the sign — is necessarily often introduced, to indicate ordinary degrees of cold, and the degrees are so large that fractional parts of a degree are frequently to be noted.

CENTRAL. Relating to a centre.

CENTRAL ECLIPSE, is when the centres of the heavenly bodies, which are affected, exactly coincide, or are directly in a line with the spectator.

CENTRAL FORCES. The two antagonist forces by which bodies are caused to revolve round a central point. These are the centrifugal and centripetal forces, acting in equilibrium to each other: were the former of these only to act, the moving body would fly away from the centre; if the latter, it would soon approach and coalesce with the centre, or be attracted to it. If these forces act un-

equally, a corresponding effect will be produced, according as one or the other preponderates; but when they are in equilibrium, they of necessity balance each other, and rotatory motion is produced. Thus it is that the satellites or moons revolve around their primary planets, and these around the sun.

CENTRE. The middle point of anything; that is, a point which is equally distant from every part of the circumference or extremity, as in a circle, a sphere, &c. The above definition is not correct in practice so much as in theory, as, by it, no solid body which is not globular, nor any flat body which is not a circle, can have a centre; yet the term is used to designate a point in a body nearest to where the mathematical centre should be. For example—cut a circular piece of wood of which the centre is known, into a hexagon, octagon, or other regular figure, and the point which was the centre before the wood was cut, will be the centre still, although the angles of it are farther from that point than the centre of the sides.

CENTRE of Attraction, is that point in a body, into which, if all its substance be collected, its action upon any remote object would be just the same as if that body retained its form.

CENTRE of Equal Attraction, is that point between two bodies in which it is equally attracted to both, as an iron ball may be equally attracted to two opposite magnets, and consequently will coalesce with neither.

CENTRE of a Conic Section, is that point which bisects any diameter, or that point in which all the diameters intersect each other. This point is in an ellipse within the figure, in the hyperbola without, and in the parabola at an infinite distance.

CENTRE of a Dial, is that point where the gnomon or style, which is placed parallel to the axis of the earth, intersects the plane of the dial.

CENTRE of Friction, that point on which anything turns, when put in rapid and independent motion, as a top spins round upon the end of the peg; this point therefore is the centre of friction.

CENTRE of Gravity of any body or system of bodies, is that point upon which the body or system of bodies acted upon only by the force of gravity, will be balanced in every possible position in which it can be placed: thus—if a scale beam be horizontal when suspended, it shows that it is suspended by its centre of gravity. The whole stability of buildings and the art of balancing depends upon knowing the centre of gravity of the body set up, and keeping that point as near the centre of the base of the body as possible.

CENTRE of Motion. That point which remains mathematically as rest when the other parts of the body are in motion. For exam-

ple—the centre of a revolving wheel, a lathe mandril, &c., is mathematically at rest, though the other parts are revolving rapidly.

CENTRE of Oscillation. The centre of gravity of a pendulum. As it is advisable to have this as near to the lower end as possible, the pendulum is loaded with a ball or bob, the shank of it being made very light.

CENTRE of Percussion. That point in which the whole force of a striking body is concentrated. If you strike anything a heavy blow with the part near the top of a round stick, such as a broom handle, it will jar the hand, or if struck with the part too near the middle, it will also jar the hand, but at a point about one-third the distance from the end, it will not affect the hand, but the blow will be powerful and steady, that being the centre of percussion. In a hammer the centre of percussion is in the head, that part being made heavy on purpose.

CENTRE. In building, the convex framework, generally constructed of wood, and used for the purpose of supporting an arch of stone or brick, during the time of its erection.

CENTRES, Line of. The line which connects the centres of two wheels, which work into each other.

CENTRIFUGAL. Flying from the centre.

CENTRIFUGAL FORCE. That power which tends to throw an object from a centre outwards, as mud from a coach wheel. It is this force which prevents the planets from falling towards the sun, and which makes them more massive towards the equatorial parts, than around in the polar direction. The centrifugal force of a revolving body will be in proportion to its rapidity of motion.

CENTRIFUGAL CHECK HOOKS. Supposing the machinery which raises and lowers the workmen, ores, &c., in mines were to break, or be set in too rapid motion, the suspended boxes which hold them might be dashed against the bottom of the mine, and the destruction of life or property ensue; to prevent this, centrifugal check hooks are used.

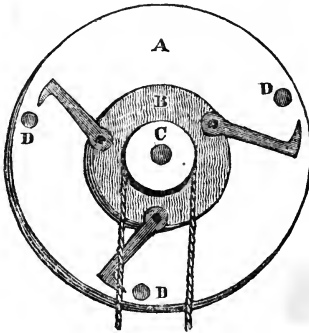

Let A in the preceding cut be a frame work, fixed against the side of the shaft of the mine. B the end of the drum, bearing the hooks, and C to represent the drum itself, upon which the rope is wound, and which rope is supposed to be on the other side of B, between it and A. If this drum obtain a dangerously-rapid motion, the hooks fastened to B fly out by centrifugal force, and one or other of them, perhaps all of them, catch hold of the studs D, and check the rapidity of motion of the descent of whatever is attached to the rope. The drum C ought besides this to be furnished with a spring, otherwise the jerk arising from the sudden stoppage of the rope would produce, perhaps, worse effects than its rapid motion.

CENTRIFUGAL HOOPS. An astronomical instrument, to show that the earth, if revolving at all, must revolve upon its shortest axis, and that owing to centrifugal force. The structure of the instrument is very simple: it consists of two or more hoops of thin tin, or brass. These are fastened below to a spindle, so that they must turn with it, but move easily above up and down that spindle when put in motion. The spindle has a pulley below, and is supported at top by a cross arm. The pulley is turned by a string passing over a multiplying wheel. Upon turning this wheel, the hoops being put in motion will endeavour to fly out by centrifugal force, and assume the shape represented by the dotted line; that is, will become an oblate spheroid, or a globular body flattened towards either pole.

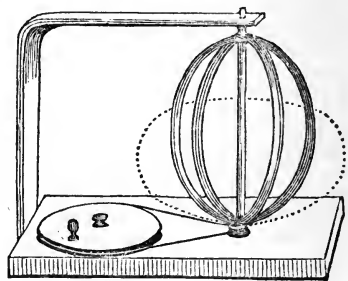

CENTRIFUGAL PUMP. A machine for raising water, dependent upon centrifugal force, combined with the pressure of the atmosphere. It consists of one, two, or more arms, erect below, and branching out above, joined to a vertical axle. Near the upper extremity of each arm is a clack valve opening upwards, while near the bottom of the vertical tube, or the bottom of each, (if these are more than one,) is a similar valve, also opening upwards. Water being poured into the machine before using, and a rapid motion being given to it by a handle at top, the water in

the arms acquires a centrifugal force, opens the valves at the end, and flies out into a circular trough prepared for it. This machine is simple, but not so effective as a well-made pump.

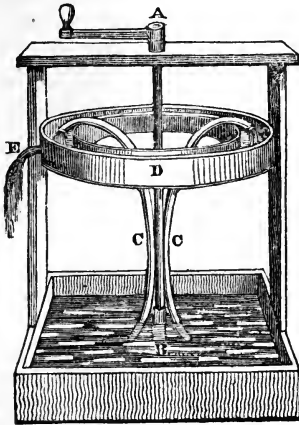

CENTRIFUGAL FORCE. (See *Gravitation*.)

CENTRO-LINEAR. An instrument for drawing lines towards a distant centre, as towards a distant vanishing point.

CERASIN. The name given by Dr. John to those gums which swell, but do not dissolve in water—such as gum tragacanth.

CERATE. A composition of hog's lard, bees' wax, and olive oil: it is used as an ointment.

CERIN. That part of common wax which is soluble in alcohol.

CERIUM. A peculiar metal, discovered in the rare metal cerite; found only in the copper mine of Bastnaes, in Sweden. Cerium extracted from its chloride by potassium, appears of a dark red or chocolate color. It acquires a metallic lustre by friction, but it does not conduct electricity well, like other metals. It has not been applied to any useful purpose.

CERO-PLASTIC. The art of modelling in wax.

CERUSE. (See *Carbonate of Lead*.)

CETINE. A name given by Chevreul to spermaceti.

CETIC ACID. Procured from spermaceti, consisting of margarine and fatty matter.

CEVADIC ACID, is prepared by converting in'o soap the seeds of the veratrum sabadilla.

CHAFERY. A kind of forge in the iron manufacture, where iron is exposed to a welding heat.

CHAIN, SURVEYOR'S CHAIN, or GUNTER'S CHAIN. A chain made of thick iron wire, consisting of 100 links, each of which is 7.92 inches, altogether making 22 yards or

4 poles, at every tenth link is a brass mark or number indicative of the distance of that mark from the end nearest to it. The chain is employed to measure land, ten chains in length and one in breadth making an acre or 100000 links. Occasionally chains of a different length are used in measuring streets, canals, roads, &c.

CHAIN PUMP. An instrument for raising water, which acts upon a principle contrary to that of the bucket engine: it may be either formed of buckets in the same manner, or what is more simple and common, instead of buckets, there are set at certain and regular intervals on an endless chain a series of pistons or round plates of metal, which nearly fit the calibre of the tubes in which they work. Putting the chain in motion, supposing the bottom of it to dip into the water of a well, each piston will inclose above it a certain quantity of water, and bear this water to the top, where it overflows into a cistern prepared to receive it.

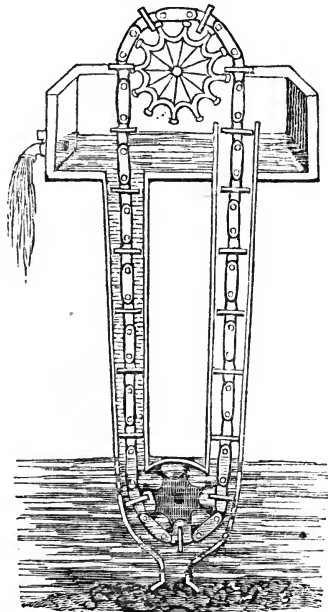

CHAIR for Railways. A socket of cast iron, used upon railways to support and secure the rails. If intended to support the ends of two consecutive rails, it is called a *double chair*, otherwise a *single or intermediate chair*.

CHALK. Carbonate of lime: it occurs of a white color, without lustre, of a fine earthy fracture, gives a white streak, and adheres to the tongue. It effervesces violently with acids, and when contaminated with iron,

becomes harder, and more or less of an ochrey tinge. In a pure state, it appears to consist of water 3 parts, lime 53, carbonic acid 42, and alumine 2 parts, in every 100. It is said, that there is but one chalk bed in the world. This begins in Poland, runs through a part of Hungary, Germany, and the Danish Islands, passes across the East and South of England, and is finally lost in the North-west of France, or rather in the Atlantic Ocean. Considering chalk geologically, it is one of the later formations or deposits, and shows by its texture, its analysis, and the very numerous remains of marine animals that have been found in it, that it has been derived by the previous agglomeration, and subsequent decomposition of testaceous animals. In the arts, chalk has many uses; as a building stone; as a material from which lime may be made; as the substance which when pounded and washed produces whiting; as an absorbent in medicine, &c.

CHALK, Black. A mineral called also drawing slate. (See *Black Chalk*.)

CHALK, French, or Spanish. Steatite, or soap stone. A soft magnesian mineral, used for the purpose of extracting grease from cloth, and as an anti-attrition powder.

CHALK, Red. A clay colored with the peroxyde of iron, of which it contains about 17 per cent.

CHALCOGRAPHY. The art of engraving on brass or copper. (See *Engraving*.)

CHALYBEATE WATERS. Such mineral waters as contain iron. Professor Hare gives the following galvanic method of making them. Form a metallic pile of pieces of silver or clear copper coin, alternating with discs of sheet iron. Such a pile placed in a vessel containing water will render it chalybeate in twenty-four hours.

CHAMBER OF A LOCK.—In inland navigation, the space between the gates of a lock in which a boat rises and sinks from one level to another, in order to pass the lock.

CHAMBLANLE. The border of stone or the wooden frame, surrounding the three sides of a door, window, or chimney. The head is called the *traverse*, and the two sides the *ascendants*.

CHAMP. A small sloping surface in architecture.



CHAMFER. A groove to receive the tenon in carpentry.

CHAMFER. Any sharp edge which is pared

off, is said to be chamfered: it differs from the *splay* in being smaller, and an equal portion being taken off on both sides, whereas a splay is taken off more on one side than another. If the corner of a wall is chamfered off, the chamfered part is often terminated by a trefoil or other ornament.

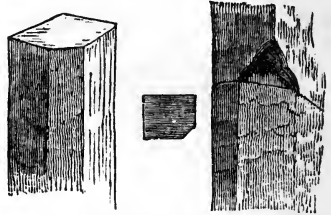

CHANCEL. The eastern part of a church, generally divided from the rest by a screen, or railing, (*cancellus*;) hence the name. The chancel of a small church answers to the choir of a large one.

CHANGES. In mathematics, the number of combinations that may be made of any certain number of things, all taken together. Thus, the number of changes that may be rung upon six bells, will be $1 \times 2 \times 3 \times 4 \times 5 \times 6 = 720$.

CHANNEL. A canal or long gutter, sunk within the surface of a body.

CHANNEL of the Larmier. (See *Canal*.)

CHANNEL of the Volute. (See *Canal*.)

CHANNEL STONES. In paving, are those prepared for gutters, or channels, for collecting and turning off the rain water.

CHANTRY. A sepulchral chapel, in which masses for the dead were chanted; when dedicated to a saint, it was called a shrine.

CHAPIFER. An old word for the capital of a column.

CHAPLET. A small ornament, cut in beads, &c. (See *Bead*.)

CHAPTER HOUSE. A room in a cathedral where the dean and chapter assemble on affairs of business.

CHAR. To hew or work, as charred stone is hewn stone; or it means partially to burn, as charred piles, stakes, &c., are such as are burned on the surface, to render them less perishable in water.

CHARACTERS. The peculiarities by which substances in chemistry, styles of architecture, &c., are known and designated; also, all the marks, symbols, and abbreviations, by which they are represented, or which are used instead of the words necessary to express certain operations. The characters used in various sciences are for the most part peculiar to them, or are used only in the same range of operations. Thus all the mathematical sciences employ but one class of characters; astronomy another; and so on. (See *Mathematical*, *Astronomical*, &c.)

Verbal characters may represent a whole class of bodies, as characters of the acids, or they may refer only to a particular family, when they would be called *generic* characters; or to a single individual, when the term *specific* character would be more applicable.

CHARACTERISTIC. In mathematics, the same as exponent.

CHARCOAL. Half burnt wood—that is, wood so dried by fire as to have the whole of the oxygen and hydrogen which is inherent in all woody substances driven off, while the third constituent, carbon, remains. (For its manufacture and properties, see *Carbon*.) Charcoal, used by the engraver for cleaning copper and steel plates, and also that used by the artist for drawing, should be chosen of clean grain without knots, and with every particle of bark or other impurity scraped away, willow, alder, and poplar, is most esteemed. By the lecturer to burn in oxygen, it should be the bark or near the out-side of the stick, because such throws off more beautiful sparks. The charcoal most proper for galvanic deflagration is always made of box wood—thus: cut the wood into slips with a saw; nearly fill a crucible with the slips, cover these entirely with sand, and put the crucible in the fire: after the whole has become red hot, and remained so half an hour, the charcoal is ready. The more it is burnt, the better conductor of electricity charcoal becomes—that is, within certain limits.

CHARGE, Electrical, signifies such a concentration of the electrical fluid at any given part of an apparatus as induces it to fly off with violence from the charged body. The term is generally applied to Leyden jars, or batteries and prime conductor, when the fluid within or on the surface of them is disturbed to the greatest degree of which they are capable.

CHARGED. In architecture, implies that one member of an edifice is loaded with and supports another. Thus a frieze is said to be charged with such and such an ornament. A column supporting an entablature is also said to be charged with it. In painting the same term is used to express the character of a picture, when derived from color rather than from drawing; for example, sunlight is indicated, not so much by figure, as by *charging* particular parts of the picture by strong touches of light.

CHART, or SEA CHART. A certain portion of the sea depicted on paper, with the bearings of the land, magnetic variation, &c., expressed upon it, for the use of navigators. If in the projection of these, the earth is considered a flat surface, they are called *plane* charts. If of any extent plane charts must be distorted representations, because of the earth being globular. When drawn so as to make due allowance for the earth's rotundity,

though the lines of latitude are still straight; the chart is called a *Mercator's* chart. *Hydrographical* charts are such as have several parts of the land and sea depicted, with their bearings, coasts, rocks, &c. *Selenographic* charts are particular descriptions of the appearances and spots on the moon. *Topographical* charts are draughts of some small portion of the earth's surface, as of a district, town, &c.

CHASE. A frame of iron, used by the printer to block or wedge up, and hold the type, when set up and arranged ready for printing from. Chases are of various sizes, but always six-tenths of an inch in thickness.

CHASING. The art of embossing upon metals, or of representing in bas relief various ornamental figures and designs, by punching them out from behind, and carving them on the front with small chisels and gravers. Chased articles, when made solid, are cast at first as near as possible of the proper form.

CHAUFER. The name given to a small table furnace. It may be made of iron, or

what is cheaper, of a large black-lead crucible, or melting pot. The usual form of the iron chauffer is represented in the cut: it is made in two parts, the lower of which is a cylinder of sheet iron, with a close bottom; holes around and above it, to supply air to the fire, and a grating loosely dropping in, and resting above the holes. The fuel is put in at the top, as is also a crucible to be heated. When a greater degree of heat is required, a funnel-shaped chimney is fitted on to the iron cylinder. If made of a black-lead crucible, holes may be drilled through the substance of it, near the bottom, and a moveable set of bars may drop it to the proper depth. This retains the heat better than an iron furnace.



CHAYA ROOT. The root of *oldenlandia umbellata*, which grows wild on the coast of Coromandel; and is likewise cultivated there for the use of dyers and calico printers. It produces a color similar to, but superior to that of madder.

CHEESE CEMENT. A kind of glue, particularly serviceable in joining broken china, wood that is exposed to wet, painter's panel boards, &c. It may be made as follows:— Pound some Cheshire cheese, wash away the soluble part with warm water, dry the remainder, and mix it with quick lime. Pound them together, and when wanted for use, add water to make the mixture of a proper consistence. This cement laid on like glue, dries quickly, becomes very hard, and when dry cannot be afterwards dissolved.

CHEF D'ŒUVRE. A masterpiece, a fine work of art.

CHEMICAL ACTION. The effect which takes place when two bodies combine or are disunited from each other, one or both bodies being altered in properties by the combination or disunion. Thus, chlorate of potass and sulphuric acid, show when united a chemical action, as they burst into flame and are resolved into other substances. (See *Chemical Attraction*.) This action may be induced by mixture as above; by heat as in firing gunpowder; by electricity as in the decomposition of water; by light as in the blackness induced upon nitrate of silver when exposed to the sun; and by other causes, such as pressure, cold, &c.

CHEMICAL ATTRACTION, or AFFINITY. (See *Attraction*.)

CHEMICAL COMBINATION is that intimate union of two or more bodies, which forms a compound differing in one or more of its essential qualities from either of the simple bodies from which it was formed.

CHEMICAL EQUIVALENTS. (See *Equivalents*.)

CHEMICAL FURNACE. Such a furnace as is adapted to chemical purposes. It ought to be capable of heating vessels not merely as in a common fire, but if necessary, such as may be used as a blast furnace. It should also be furnished with a tube running through the fire for the decomposition of liquids, and with a sand bath for the gradually drying of powders and heating of glass vessels. Such a furnace is described under the word *Black*. The following is the form used at the Royal Institution, and advocated by Professor Brande.

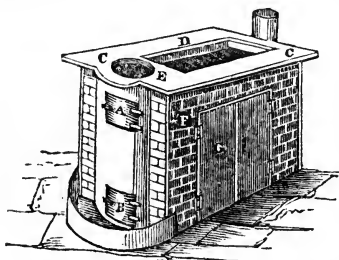

C C is an iron plate supported upon four brick walls, and perforated with a square hole D, and a round one E. In D is placed a square iron trough filled with sand, for a sand bath. In the hole C fit various vessels, such as an iron pot, still, &c., or it is left open for the insertion of crucibles, muffles, and other chemical apparatus. C is exactly over the fire; D is over the flue only, and about three inches deep; A is the fire-place door; B the ash-hole; F a hole proceeding to the fire for the insertion of a tube. When not

wanted, this hole is stopped with a plug. G a cupboard under the flue for holding fuel, or with shelves to keep deliquescent salts, dishes for slow evaporations, &c.

CHEMICAL TEST. (See *Test*.)

CHEMICAL THERMOMETER. A thermometer, the scale of which is not exposed to a contact with corrosive or coloring liquids. The French chemical thermometer is mostly a glass tube, which contains a thermometer and scale, or else the scale alone is defended by the extra tube. See figures A B C. The English chemical thermometer is made and graduated like the common one, except that the lower part of the scale is made with a hinge which folds back, so that the ball alone is immersed in the liquid, the temperature of which is to be ascertained, fig. D.

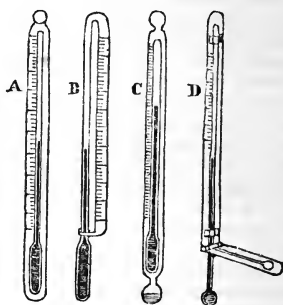

CHEMISTRY. Brande defines chemistry as "an art which teaches us the properties of the elementary substances, and of their mutual combinations. It inquires into the laws which affect, and into the powers which preside over their union; it examines the proportions in which they combine, and the modes of separating them when combined; and endeavours to apply such knowledge to the explication of natural phenomena, and to useful purposes in the arts of life." It is divided into *organic* chemistry, and *inorganic* chemistry. The first treating of organized bodies, such as plants and animals; the other of unorganized, such as minerals and factitious products. The latter division of the subject is further subdivided into *analytical* and *synthetic*, or the art of separating and the art of combining bodies; also that part of inorganic chemistry which relates to the gases is often called *pneumatic chemistry*.

CHEVAUX DE FRISE. Fixed lances, or spikes, so arranged that their points cross

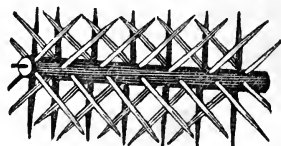

each other, and offer an impediment in every direction to the passage of a person or horse across them.

CHEVRON, or ZIGZAG WORK. An ornament characteristic of Norman architecture, though found occasionally among the early English buildings.

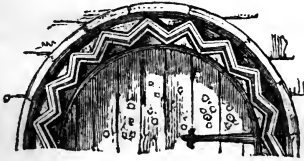

CHIARO-OSCURO. In painting, the art of judiciously distributing the lights and shadows of a picture; also it is used to designate those pictures which are painted with white and one other single color, yet representing the object in its natural tint—such, for example, would be the representation of a piece of statuary, if drawn upon tinted paper with black chalk, the lights being thrown in with white.

CHILIAD. An assemblage of several things ranged by thousands. The term was particularly applied to tables of logarithms, which were first arranged in thousands.

CHILAGON. A plain figure of 1000 sides and angles.

CHILL HARDENING. A method of tempering steel cutting implements, by subjecting them, when red hot, to a strong blast of cold air, by which they become hardened, as if they had been plunged into a cold liquid, though more delicately. It is said that the method succeeds best with case-hardened goods.

CHIME, Electrical. An instrument to produce the musical sound of a small chime of bells by electrical agency.

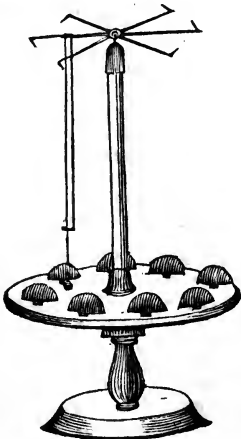

The foot-board has arranged on it several bells, placed so that their inner edges are in a circle. In the centre is a glass rod, bearing upon it a moveable flyer, made of wire. (See *Flyer*.) A wire hangs perpendicularly down from one arm of this, near to the bells, and has the lower end turned up at an angle, and perforated, to guide a silk thread, which bears a small metal ball. When the apparatus is electrified, the flyer turns round, and the ball or clapper strikes each bell in succession, producing thereby an agreeable sound.

CHIME, Electro-magnetic. Any of the rotatory electro-magnetic apparatus may be made subservient in moving a clapper against a chime of bells. The rotatory bucket of Ampere, (see *Ampere*,) is that usually employed for the purpose, as follows :—

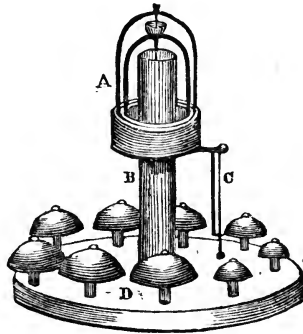

A is the rotating bucket. B the magnet, about the pole of which it rotates. C the clapper, suspended on a thread, with a wire to control its centrifugal motion. D the stand for the chime of bells.

CHIMNEY. That part of a building in which the fire is contained, and through which the smoke passes away. The parts of a chimney are as follows :—The opening into the room, called the *fire-place*. The stone or bricks under the fire-place, or the *hearth*. That on the same level before the fire-place, or the *slab*. The vertical sides of the opening, and which form also part of the walls of the apartment, are called *jamb*s. The stone or wood resting on these is the *mantle*. The shelf which rests upon this, the *mantle shelf*. The whole hollow space from the fire-place to the top of the wall is the *funnel*. The part of the funnel where it contracts above the stove is the *gathering*. From this place, which is called the *throat* of the chimney, to the top is the *flue*. The wall of the apartment, which covers over the flue, and proceeds from the mantle upwards to the ceiling, is the *breast* of the chimney. The portion above the roof is the shaft, and the upper extremity the chimney top, which is usually crowned with a hood, vane, or chimney pot.

CHINA GLAZE, for printing blue ware, is made by mixing 10 parts of glass, 2 parts of lead, and 3 or more of blue calx.

CHINA WARE. A fine description of porcelain, either brought from the East, or formed in imitation of such as is made there. Its particular excellence is derived from the fine quality of the clay employed. (See *Clay*.)

CHINESE FIRE. A composition used in fire works. It is made by mixing the following ingredients, and ramming the mixture into rocket and other cases: *Red*—Saltpetre, 1 lb.; sulphur, 3 oz.; charcoal, 4 oz.; iron-sand, 7 oz. *White*—Saltpetre, 1 lb.; bruised gunpowder, 12 oz.; charcoal, 8 oz.; iron-sand, 11 oz.

CHIP. A small piece cut away from any material by an acute angled instrument.

CHIPPING. The operation of cutting away small irregular pieces from a block of stone, or a brick, to hew it into a required form. Also taking off, by means of chisels, the outer rind or coat of cast iron, previous to smoothing the surface by files.

CHIPPING PIECES. The projecting pieces of iron cast on the facings of iron framing, when intended to be rested against each other.

CHISEL. An instrument used in masonry, carpentry, and joining; and also by statuaries, carvers, and numerous other artizans, for cutting either by the impulse of pressure, or of the blows of a mallet or hammer. There are numerous kinds of chisels, named according to the uses to which they are applied.

CHIT. An instrument for cleaving lathes, sometimes called a cleaving iron.

CHITINE. A new principle discovered by M. Odier in insects, by plunging beetles, &c. into a hot solution of potass, which dissolves all but the chitine. It is, therefore, insoluble in a solution of potass, but soluble in hot sulphuric acid. It burns without losing its form, and nitric acid does not turn it yellow. It contains no azote.

CHLANDI'S LINES. If a plate of glass be held either by the middle, the edge, or the corner, some sand or other powder be sprinkled over it, and a violin bow be then drawn across the edge of the glass, so as to produce a sound from it, it will be observed that the glass vibrates only in particular parts, where the sand will be scattered, the remaining parts of the glass remaining at rest; the sand will then become collected together in the form of lines of considerable regularity and variety; these are called nodal lines, or from their discoverer, Chlandi's lines. Their variety and frequency depends upon the degree of pressure of the bow, and the part of the glass to which the force is applied. In the complex figures annexed as examples, two and sometimes three bows are used at different parts of the glass, giving it a compound vibration:—

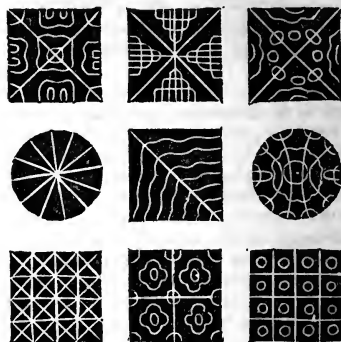
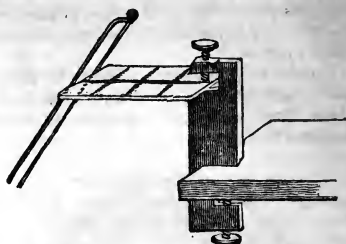

CHLORAL. A kind of ether, produced by passing a large quantity of chlorine, carefully dried, through anhydrous alcohol. This process is continued for several days, and several hours each day. The product is mixed with twice its weight of sulphuric acid, and distilled, and afterwards again distilled off fresh acid. It is of no known use.

CHLORATES. Combinations of the chloric acid and alkaline or metallic bases. They were formerly called oxy muriates.

CHLORATE MATCHES, are made by dipping small strips of wood, or card, into a mixture of chlorate of potass, made as follows:—Gently mix together, with a knife or spatula, 30 parts of the chlorate of potass, in fine powder, with 10 parts of powdered sulphur, 8 of sugar, 5 of gum arabic, both also powdered, with enough of vermilion to give it a rose-colored tint, and water to reduce it into a thin paste; the sulphur should be added last. When dry, the matches are to be inflamed by touching them with sulphuric acid, which is usually kept in a phial for that purpose.

CHLORIC ACID. A sour colorless fluid, not existing but in union with water or some base. It may be procured by passing a current of chlorine through a mixture of oxyde of silver and water. The excess of chlorine which the filtered liquid contains is separable by heat, and the chloric acid dissolved in water remains. Its compounds are called chlorates, or oxy muriates.

CHLORIDES. Salts which are a combination of hydrochloric acid, with bases, formerly called muriates.

CHLORINE. The name given by Sir Humphrey Davy to a gas, which long went by the name of oxy muriatic acid gas, as being imagined to be a compound of oxygen and muriatic acid, but which he showed to be a simple substance, which when combined with hydrogen, formed muriatic acid. Chlorine is commonly obtained in the small way by distilling in a glass retort, at a gentle heat, 3 parts of common salt, 1 part of black oxyde of manganese, and 2 parts of sulphuric acid. The gas which comes over is of a yellowish green color, and its odour and taste are so strong, stifling, and characteristic, that it is impossible to mistake it for any other gas. Like oxygen it is a supporter of combustion, the products of which are termed chlorides. It has two remarkable properties. First—Its affinity for hydrogen is superior to that of any other substance, whence it is extremely useful in destroying contagious miasmata; and second—Its destructive action upon vegetable colors, when aided with a little moisture. Scheele first remarked this property; Berthollet applied it to bleaching in France, and Mr. Watt introduced its use into Great Britain. The alkaline metals, as well as copper, tin, arsenic, zinc, antimony, in fine laminæ or filings, burn spontaneously in chlorine, and phosphorus takes fire in it at ordinary temperatures.

CHLORIODIC ACID. A union of 2 proportional parts of chlorine, and 1 of iodine.

CHLORIONIC ACID. A union of 1 proportional each of chlorine and of iodine, but which forms no permanent compound.—*Brande.*

CHLORO-CARBONIC ACID. A gaseous compound, procured by exposing a mixture of equal measures of dry chlorine and carbonic oxyde gases to sunshine.

CHLOROCHROMIC ACID. A gaseous compound, formed by the action of sulphuric acid on a mixture of chloride of sodium, (common salt,) and chromate of lead.

CHLORO CYANIC ACID, was named by Berthollet the oxyprussic acid. It is procured by transmitting a stream of chlorine gas into an aqueous solution of hydrocyanic acid, removing the excess of chlorine by agitation with mercury, and then expelling by heat the gaseous cyanide of chlorine. It is soluble in water and alcohol.

CHLOROFORM. A dense limpid fluid, obtained by the distillation of chloral with lime and water, and afterwards shaking it with sulphuric acid, and finally distilling it over barytes, in a dry retort.

CHLOROMETRY, is the name given by the French to the process for testing the de-coloring power of any combination of chlo-

rine. The usual method is to procure a solution of indigo of a known strength, and mixing the solution of chlorine with it until the blue color is destroyed, when the greater or less quantity of chlorine which has been found necessary will indicate the strength of it.

CHLOROMETER. An instrument to measure the quantity of chlorine in any salt or solution. One described by Dr. Ure is as follows:—He says, “as chlorine or chloride of lime, when mixed with water of ammonia, causes the dis-engagement of azote, the quantity of this gas evolved may be made the foundation of an accurate chlorometer. The two substances should be mixed over mercury in a graduated syphon tube. The short end A, and the open end B, are both graduated to one scale; for example, to hundredths of a cubic inch, or to grain or 10-grain measures. The tube is to be filled with mercury, and then ten measures of it are to be displaced at the open end, by inserting a wooden plug. This space being filled with the solution of chloride of lime is to be turned up into the short end, by covering the open end with the finger, and inverting the tube. The ammonia being now let up will cause a reaction, and evolve a quantity of azote, equivalent to the chlorine present.”



CHLORONITROUS GAS. When fused chloride of calcium, (muriate of lime,) is moistened with nitric acid, a pale reddish yellow gas is evolved, composed of equal volumes of chlorine and nitric oxyde, combined without condensation.

CHLORO-OXALIC ACID. Procured by treating crystallizable acetic acid with dry chlorine in excess. It forms rhombic, dendritic crystals.

CHLOROPHANE. A bluish green variety of Derbyshire spar or fluat of lime, which, when slightly heated, gives, for some time afterwards, a beautiful green phosphorescent light.

CHLOROPHYLE. The green coloring matter of the leaves of plants.

CHLORIC OXYDE. Deutoxyde of chlorine.

CHLOROUS ACID, supposed to be identical with peroxide of chlorine.

CHLOROUS OXYDE. Protoxyde of chlorine, called also eu chlorine.

CHLORURETS, the same as chlorides, formerly called muriates.

CHOAK DAMP. Carbonic acid gas.

CHOCK. A loose piece of wood, stone or metal, put into any piece of machinery for the purpose of filling up a cavity, or of adding a greater weight to it. Thus the stones with which a mangle is filled are chocks, so also is the weight rested upon a bush harrow—upon a bellows, &c.

CHOIR. The chancel of collegiate or cathedral churches.

CHOLESTERATES. Salts formed with cholesteric acid.

CHOLESTERIC ACID is formed by heating cholesterine with its own weight of concentrated nitric acid. It is orange yellow in the mass, but the crystals are white and acicular. It is soluble in alcohol, insoluble in water.

CHOLESTERINE. The basis of animal bile, procured by reducing human gall stones to powder, adding boiling alcohol, and filtering the solution rapidly. It is crystalline, lamellar, white, brilliant, and very like spermaceti.

CHOLATES. Salts formed with cholic acid.

CHOLIC ACID. A peculiar animal acid found in human gall, in which it exists as cholate of soda.

CHONDRONETER. A balance for weighing corn; upon the principle of the steel-yard.

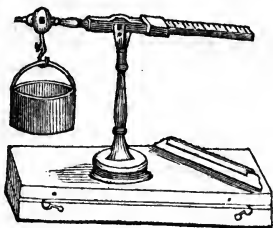

It consists of a small measure holding about half a pint, which is balanced by a beam and sliding weight on the opposite side of the fulcrum. This beam is so graduated that when the measure is filled even with the top with corn, and the weight is moved along the beam, it indicates not the positive weight of the corn in the measure, but how much such corn would weigh per bushel; for example—if the weight stands at 40, the corn would weigh so much per bushel; and the other conditions of it being the same, the value of the corn would be in proportion, according to its kind.

CHORD. A right line joining the extremities of an arc.

CHOROGRAPHY. The art of drawing maps of particular provinces or districts. It is, therefore, less extensive than geography, which includes a description of the whole earth, and more extensive than topography, which confines itself to a single place or town.

CHRISTISON'S APPARATUS, for detecting poisons. Fig. A, B, C, D, E, F. A is an instrument for reducing the sulphurets of some of the metals by a stream of hydrogen gas. B a funnel-shaped tube for testing minute portions of liquids. C a tube for reducing a small quantity of mercury. D a tube for taking up a minute globule of ditto. E bottle and tube for washing down scanty precipitates or filters. F apparatus for the distillation of fluids supposed to contain acids.

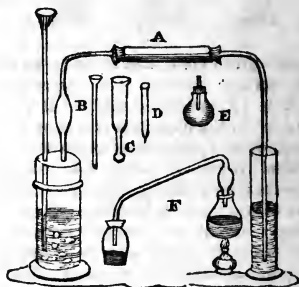

CHROMATES. Salts formed by a union of the alkalis, earths, and metals, with the chromic acid. The principal chromates used in the arts are those of potass, and lead.

CHROMATE OF POTASS is prepared by exposing a mixture of 4 parts native chromate of iron with 1 of nitre, to a strong heat for some hours, and washing out the resulting soluble matter; these washings yield chromate of potass by evaporation. It is in the state of yellow crystals, which dissolve in water, but not in alcohol. It is valuable to the calico printers, in the manufacture of chrome colors, and as a chemical test, precipitating the metals of very different and often beautiful colors. The bichromate of potass is made from the chromate by adding to its solution a sufficiency of sulphuric acid to give it a sour taste, setting it aside for a day or two, when deep red crystals will be deposited. This salt is largely manufactured in the North for the use of calico printers.

CHROMATE OF LEAD. (See *Chrome Yellow*.)

CHROMATICS. That division of the science of optics which treats of the colors of light, their several properties, and the laws by which they are separated, and their separated parts re-combined.

CHROMATIC VERNIER. An instrument, invented by Dr. Brewster, for ascertaining by comparison faint differences in the tints of polarized light. It consists of a thick piece of plate glass, ground to the shape of a wedge, and which has been rendered red hot, and then rapidly cooled at the edges, which

gives it a double-refractive structure. (See A B in the following cut.) By this operation

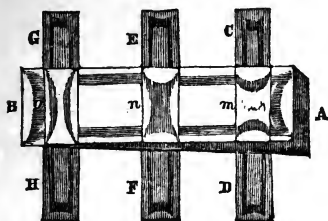

its tints will increase from B to A, so that if the maximum tint near A is a full yellow, it will shade off in white near B. In a wedge of this kind, 2 inches long and 8° of angular measurement, we have an instrument of considerable extent. To use it, if it be required to ascertain very exactly the tint of a plate of crystal, it must be held to the light, as in the figure, and moved gradually from A to B. When it has the position C D, the figure *m* is opened horizontally, which proves that the tints of the wedge are higher at the point *m* than those of C D. In the position G H the tints are opened vertically, and therefore the tints of the crystal are higher than those of the wedge. But in the intermediate position E F a dark cross is produced, which indicates the perfect equality of the tints of the glass and crystal. Thus by a graduated scale attached to the instrument all tints may be compared to each other.

CHROME COLORS. A name employed by artists and painters to designate any colors, which, when dry, are of that soft powdery consistence that they may be mixed up with oil, and form a uniform soft color, without grinding with the muller. Those colors which are truly chromes must have the metal chromium in their composition, and are the following, though many other colors besides these would be included in the first general definition.

CHROME BLUE, or a blue oxyde of chromium, may be made thus:—Make a saturated solution of chromate of potass, add weak sulphuric acid to combine with the potass. Then add one-eighth part of common salt, and one-sixteenth by weight of strong sulphuric acid. The liquor will now assume a green color. It is then evaporated to dryness; then re-dissolved, and filtered; finally the greenish blue oxyde of chromium is to be precipitated by caustic potash, and collected on a filter. It is used chiefly as an enamel color.

CHROME GREEN. A color extensively used in dyeing, and for the staining articles of porcelain of a fine green color. It may be economically and easily made by boiling

chromate of potass, dissolved in water, with half its weight of flowers of sulphur, till the resulting green precipitate ceases to increase, which may be readily ascertained by filtering a little of the mixture. The addition of some potass accelerates the operation.

CHROME RED. This is a subchromate of lead procured thus—Into saltpetre, brought to fusion in a crucible at a gentle heat, pure chrome yellow is to be thrown by small portions at a time. A strong ebullition takes place at each addition, and the mass becomes black and remains so while it is hot. Suffering it to rest for a few minutes, during which the dense basic salt falls to the bottom, the fluid part is to be poured off. The mass remaining in the crucible is to be washed and dried, forming the red powder required. This color as well as the next are used extensively in dyeing, and by the painter both in oil and in water colors.

CHROME YELLOW, ORANGE, &c., or CHROMATE OF LEAD. A rich pigment of various shades from deep orange to pale yellow. It is made by adding a limpid solution of the chromate of potass to a solution, equally limpid, of acetate or nitrate of lead. A precipitate falls, which must be well washed and carefully dried out of the reach of sulphuretted vapours, a lighter shade of yellow is obtained by mixing some solution of alum or sulphuric acid with the chromate, before pouring it into the solution of lead, and an orange tint is to be procured by the addition of subacetate of lead in any desired proportion.

CHROMIC ACID, or PEROXYDE OF CHROME, is a ruby red powder, of a sour metallic taste, extracted from the red lead ore of Siberia, and also from the mineral chromate of iron. From the former it is procured by treating it with carbonate of potass, and separating the alkali by means of a more powerful acid, or it may be made by decomposing any of the artificial chromates. Chromic acid unites with the alkalis, and most of the earths and metals; forming chromates.

CHROMIUM. A metal of an iron grey color, procured by intensely heating its native combinations, which are those of iron and lead, with charcoal. It is brittle, difficult of fusion, and not easily acted upon by acids. It unites with oxygen in three proportions, forming a sesquioxide, a deutoxide, and a peroxyde; the latter of which having acid properties is called also chromic acid. It also unites with chlorine, fluorine, sulphur, nitrogen, phosphorus, and carbon.

CHRONOMETER. A watch or small time piece, made with such exactness as not to alter its rate of going by change of climate, or position, or any other natural and ordi-

nary casualty to which it may be exposed. As ships at sea have in hazy weather no means of ascertaining time but by the chronometers, it is necessary that every care should be taken in their construction.

CHRYSOBERYL. A precious stone of a pale green color, resembling the beryl and aquamarine.

CHRYSLITE. A precious stone of a yellow color, intermediate in hardness between amethyst and felspar. It is often called the yellow topaz.

CHUCK. An appendage to a lathe, which being screwed on to the nose of the mandril enables the workman to fix firmly any material that he may be desirous of turning. Chucks are either simple or compound. Simple chucks, the names of which are the *Arbor, Branch, Driver, Ring, Surface, Universal, &c.*, and under which names they are described and figured, have no tendency to alter the centre of rotation of the work fixed to them, it always corresponding to that of the mandril; but the compound chucks, such as the oval, the eccentric, &c., have such capabilities of adjustment, that the centre may be changed at pleasure, and also allow of such movements that the circularity of motion may be changed into other curves.

CILERY. The drapery or foliage on the heads of columns, not applied to the classical orders, but rather to the undefinable and diversified ornaments found in Gothic, Moorish, and similar buildings.

CILL. (See *Sill*.)

CIMA, or OGEE. A moulding waved on its contour; one part being concave, the other convex. There are two kinds—the *upright ogee*, in which the concave part projects most, and the *heel or inverted ogee*, which has the convexity most prominent. This last, with its fillet above, is always the upper moulding of a classical cornice.



CIMBIA. A fillet, string, list, or cincture, around any part of a building.

CINCHONATES, or QUINATES. Compositions of cinchonic acid and various bases.

CINCHONIC, or KINIC ACID. An acid, contained in different species of cinchona, existing in the state of cinchonate of lime.

CITREAL. Oil of lemons.

CINCHONINE, or CINCHONIA. An alkaloid which forms the distinguishing character of Peruvian bark, and in which alone its medicinal properties appear concentrated.

It is extracted from the *pale bark*, while an analogous substance, called *quinia*, is extracted from the *red bark*. The only difference between them appearing to be that the latter contains a double quantity of oxygen in its composition.

CINCTURE. A ring or fillet at the top or bottom of the shaft of a column, called also the *astragal*, (which see.)

CINNABAR. A beautiful red pigment, composed of sulphur and mercury; hence in chemical nomenclature called *sulphuret of mercury*. (See *Vermillion*.)

CINQUEFOIL. An ornament of five leaves united; common in the tracery of windows, in parapets, &c., of Gothic buildings.

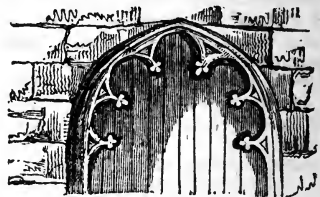

CIPHER. One of the numerals, marked 0, signifying nothing by itself, nor yet when placed on the left-hand side of a common number, or the right-hand of a decimal; yet when placed on the left of the latter it diminishes it ten-fold, and when on the right of a common number it increases it in a like proportion.

CIRCLE. A plane figure, bounded by a curved line, which is everywhere equally distant from a certain point within it, called the centre. All circles are supposed to be divided into 360°. (See *Angle*.) The length of the degree varying according to the size of the circle.

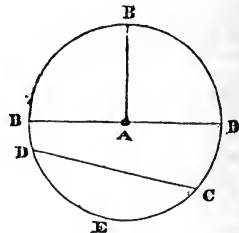

The principal parts of a circle are the *centre*, A; the *circumference* or outer line B B B C E D; the *diameter*, which is any line drawn across from one side to the other, and through the centre, as B A B, and the *radius*, which is half a diameter, or the distance from the centre to the circumference A B. Half a circle is a *semi-circle*; one quarter is called a *quadrant*; one-sixth is a

secant, &c. A line which passes across a circle, if not a diameter, is called a *chord*, as C D, and the portion of the circle cut off by it is a *segment*, while the part of the circumference thus cut off is an *arc*, as C E D.

CIRCLES OF ALTITUDE, the same as the circles of latitude, but instead of being applied to find the latitude of a place, they are used to find the altitude of a heavenly body above the horizon.

CIRCLE OF CURVATURE. That circle the curvature of which is equal to that of any curve at a certain point. It is also called the circle of equal curvature.

CIRCLES OF DECLINATION. A number of circles drawn around the tropical regions of the earth, parallel to the equator, and intended to indicate the declination of the sun as he passes either of them in his passage either to or from the colures or tropics.

CIRCLES, Diurnal. Circles parallel to the equinoctial, described by the stars in their apparent diurnal rotation about the earth.

CIRCLES OF EXCURSION. Circles parallel to the ecliptic, and at such a distance from it as that the excursions of the planets may be included within them; they are usually fixed at 10°.

CIRCLE, Galvanic. Every galvanic apparatus so arranged that the fluid can circulate around, provided that apparatus also excites or disturbs the fluid in the first instance, is called a galvanic circle, because the electric fluid always endeavours to pass from one end to the other of it and back again by some other conducting channel, it may be a wire, water, charcoal, &c. Galvanic circles are either simple or compound; the former is composed of a single pair of elements and one conductor, and the latter of several simple circles following each other. A simple galvanic circle is seen below, where there are two metals; in A touching one another at top, (one metal is copper, the other zinc,) in B connected with each other by two wires, there being acidulated water between in the glass vessel. The galvanic fluid passes from the zinc to the acidulated water, hence to the copper, and through that to the zinc again, passing in a circuit or circle. A compound galvanic circle is seen in the *Couronne de Tasses*.

may be drawn straight rather than circular.

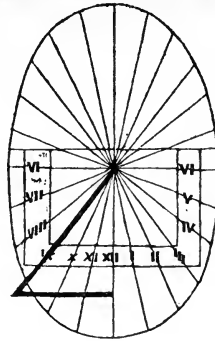

Horary, or hour circle, is also a small circle revolving with or attached to an artificial globe, being situated concentric with the pole, and intended to indicate the relative time at particular places, and to solve other problems connected with geography and astronomy.

CIRCLE OF ILLUMINATION. If a globular body be presented to a strong light, as that of the earth to the sun, one half of it exactly will be illuminated, the rest will remain in darkness. The boundary between this light and darkness is the circle of illumination. If there were no atmosphere to the earth; in passing this circle, we should immediately plunge from one extreme to the other; but owing to the refraction of the atmosphere and reflection from the surface of the earth, we have an intermediate state called *twilight*. This state, however, is exterior to the true circle of illumination.

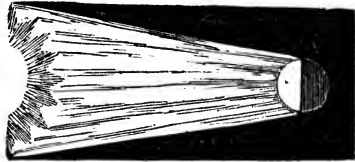

CIRCLES OF LATITUDE. Circles drawn on the artificial globe, parallel to the equator, to indicate the latitude of places upon the earth's surface. On the celestial globe they are parallel to the ecliptic, or sun's course, and serve to indicate the latitude of the stars.

CIRCLES OF LONGITUDE, or MERIDIANS OF LONGITUDE. Great circles extending from pole to pole of the earth, at equal distances from each other; of use to indicate the time of the sun's arrival at each in his apparent diurnal rotation; and thereby to indicate the relative time at different places, or their position from each other, reckoning east or west from a certain point.

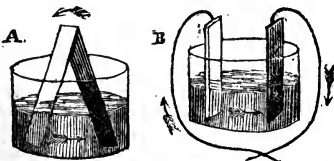

CIRCLES, Horary, in dialling, are the lines which show the hours on dials, though these

CIRCLE OF THE SPHERE. Any circle depicted on the artificial globe, for the purpose of marking the position of places, the course of a heavenly body, &c. These circles are divided into two kinds; *great circles*, or such as divide the globe into two equal portions or hemispheres; and *less circles*, or such as cut off a portion less than half. For example, the meridians of longitude, the ecliptic and the equator, are great circles. The tropics, the polar circles, the lines of latitude, both above and below the equator, are less circles, the whole of them being circles of the sphere. Corresponding terms may be used for the corresponding parts of all globes. (See *Armillary Sphere*.)

CIRCLE OF PERPETUAL APPARITION and PERPETUAL OCCULTATION. The first is a circle drawn at such a distance from the pole of the heavens, that the stars within it never set in that latitude for which the circle has been drawn. The circle of perpetual occultation is that the stars of which never rise in that latitude; therefore these circles are always of corresponding size, one around the north pole, the other round the south pole. In the space between them the stars rise and set daily. At either pole these circles will be united together in the equator, the inhabitants, if any, never seeing more than one hemisphere of stars, while those at the equator see all the stars of both hemispheres nightly. To them, therefore, the names of these circles do not apply.

CIRCLES, Polar. Two circles around the globe, at the distance of $23\frac{1}{2}^{\circ}$ from either pole, and forming the boundary between the polar regions and temperate zones. That near to the north pole is called the arctic circle, and that around the south pole the antarctic.

CIRCULAR MAGNETIC COIL. A flat coil of wire rolled up, for the purpose of transmitting a current of the electric fluid, which, passing through it, produces the effects of polarity and magnetic attraction, one side of the coil being north, the other side south. The term is used in distinction to that of helix, or a long coil of wire. The following

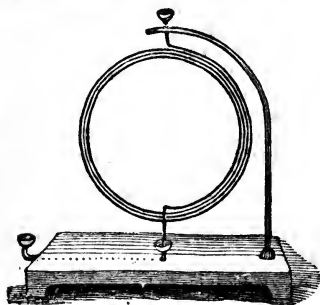

is one of the numerous magnetic circular coils. (For others, see *Cumming, De la Rive, Sturgeon, &c.*)

CIRCULAR POLARIZATION. (See *Polarization*.)

CIRCULAR SAW. A thin plate of steel, having saw-like teeth cut on the circumference, and revolving by means of a lathe, or rotating spindle, attached to it. Circular saws are much used to cut veneers as well as for rougher purposes.

CIRCULATING DECIMALS. Those which consist of a repetition of a small number of digits, therefore not terminal. For example, bring one-third into a decimal, which is done by dividing the one with ciphers added to it by 3, it will be found equal to $\cdot 3333$. The figure 3 being repeated continually, and still leaving the remainder 1, which prefixed to another cipher, will, when divided, still yield a 3, and would so for ever. $\cdot 3333$ is therefore a circulating decimal; so is $\cdot 234234$, &c.

CIRCUMFERENCE. The outer boundary of a circle or globe. (See *Circle*.) Often used to signify the outer boundary of any other shaped body, though the word periphery would here be more proper.

CIRCUMFERENTOR. An instrument used in surveying, in the same manner as a theodolite, but being a less perfect instrument, it is only employed where great accuracy is not required. It consists of a tripod stand which supports a magnetic compass furnished with two sights, the box which contains the compass being divided on its circumference into 360 degrees. The following cut is a view of the top of the box, with the sights attached to it. When used, the sights are to be directed to an object in the distance until it can be seen through them; the number of degrees indicated by the magnetic needle is then to be noted. Afterwards, the sights are to be directed to a second object, and the degrees observed in like manner; the difference between these and the former, shows the angle of position between the two places, which it is the object of the instrument to ascertain.

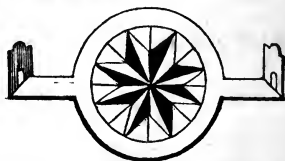

CIRCUMGYRATION. The whirling motion of a body on any given centre.

CIRCUMPOLAR STARS. Those which revolve about the pole of the earth without setting.

CIRCUMSCRIBE. To draw one figure on the outside of another, the one being recti-

linear, the other circular; or else both figures rectilinear, the sides of one figure touching all the angles of that within it.

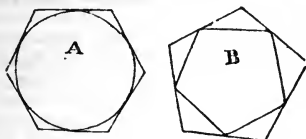

CIRCUMVALLATION. A round inclosure of trenches or fortifications.

CIRCUMVOLUTION. The act of rolling round. In architecture, the term is applied to the spirals of the Ionic capital, every turn of which is called a circumvolution.

CIRRUS, CIRRHUS, or CURL CLOUD. An extended mass of light, fleecy, or fibrous clouds, appearing like long locks of wool or cotton stretched out. Its appearance is a general indication of wind.

CIRRO-CUMULUS, or SONDER CLOUD. Clouds differing from the cirrus, in being in rather more solid and rounded masses, extended horizontally across the sky. This usually accords with a rising barometer.

CIRRO-STRATUS, or WANE CLOUD. A horizontal stratum of clouds, attenuated towards the circumference, the clouds being separate or in groups, large or small. It indicates a decrease of temperature, wind, and rain: it is often called a mackerel sky.

CISSOID. A particular kind of curve, represented and formed as follows:—

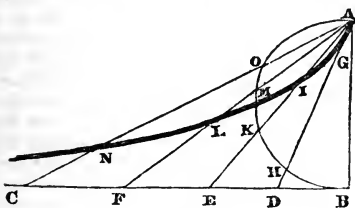

Let AB be a diameter of the circle, of which half is seen in the figure, and BC an indefinite line at right angles to AB . From A draw several lines to BC , each line cutting some part of the circumference, such as AD , AE , AF , AC ; and upon these lines set off the corresponding equal distances; viz. $DG = AH$, $EI = AK$, $FL = AM$, and $CN = AO$, then the curved line drawn through all the points is the cissoid.

CITRATES. Combinations of the citric acid with various bases. The citrate of potass is used in medicine as a mild diaphoretic.

CITRIC ACID. The acid which occasions the sour taste and properties of the lemon, lime, and other fruits. It is made thus:—Saturate the lemon juice with chalk, noting

the quantity of chalk used. The citrate of lime precipitates, the supernatant liquor is poured off, clean water added, and for every 19 pounds of chalk used, 9 and a $\frac{1}{2}$ of sulphuric acid are mixed with it. At the end of twelve hours the citrate of lime will be decomposed; dilute nitric acid will float above, and sulphate of lime be found at the bottom. The acid may be drawn off, filtered and evaporated to obtain the crystals of the acid. Citric acid forms citrates with the usual bases.

CITRIC ETHER. When a hot solution of citric acid, mixed with alcohol, muriatic acid, and a certain proportion of sulphuric ether, is kept for six or eight hours at a temperature between 125° and 135° , and then water added, citric ether separates in the form of an oil-like liquid.

CIVIL. In opposition to military or ecclesiastical; thus civil engineering is the science and art of constructing machinery for manufacturing uses, constructions, and excavations, of general transit, or ordinary purposes, &c. Civil architecture teaches the construction of private dwellings, public offices, palaces, &c. A civil year is one by which we compute ordinary time, without reference to exact astronomical accuracy. A civil day has no reference to light or darkness, but consists of twenty-four hours, and begins at 12 o'clock at night, &c.

CLACK. A bell, so contrived that it shall ring when more corn is wanted in a corn mill; when any thing is wrong in the working of a steam engine, &c.; or generally a clack is any thing which makes a clacking or ringing noise.

CLACK VALVE. An extremely common valve, used generally in hydraulic and steam machinery, also for blowing machines, bellows, &c. The following figure will render its construction evident:— A represents the valve open. B the same closed. It is merely a flap of leather, wood, or metal, which covers a hole, and which is attached to the side of that hole by a hinge. It is often called a flap valve.

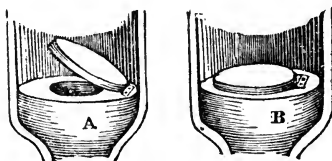

CLAMP. A bar of metal bent, or piece of wood cut into a curved form, and furnished at one end with a screw; the whole intended to affix two articles together, sometimes permanent, but more frequently for a temporary purpose. For example, in glueing together various parts of furniture, clamps are used

until the glue is dry; so also a small air pump, electrical machine, or other apparatus, is held to a table while working it, by means of a clamp. The following are among the numerous forms given to clamps:—

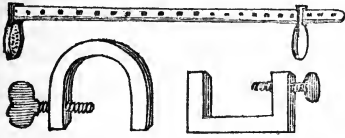

CLAMP. A pile of unburnt bricks raised for burning.

CLARIFICATION. The process of freeing any liquid from its impurities, by throwing them down by a chemical or mechanical mixture added to them. For example, boiling clarifies numerous extracts; hops clarify beer; alum added to new gin throws down any excess of the oil of juniper, and enables it to mix with water without turning cloudy. These are instances of clarification, and as such are not to be confounded with filtering.

CLARK'S (DR.) COMPRESSION BLOW-PIPE. A powerful, but somewhat dangerous instrument, the action of which is derived from mixed gases; (that is, oxygen 1 part, and hydrogen 2 parts,) being powerfully compressed in an appropriate vessel, and rushing out with force through a jet upon the substances to be operated upon. Its construction is as follows:—

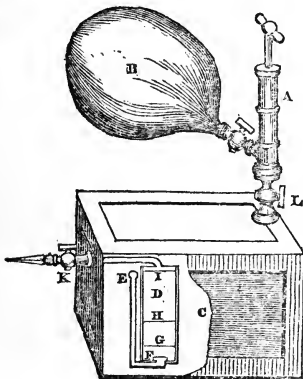

A is an exhausting and condensing syringe; intended, first, to draw the atmospheric air from the square box C, and afterwards to compress into it the mixed gases contained in B. The stop-cock L is then closed, and the gases within C rush down the tube E, through a piece of fine wire-gauze at the top of it, and afterwards through the water F into the vessel D. This vessel is filled with

water to about H, and has a piece of wire-gauze across it at G, and another piece at I. Through this piece it is that the gas finally escapes to supply the jet K. The cock belonging to this being opened the gas issues. It is a dangerous instrument, because in proportion as the gas issues, and the compression is diminished, the flame has a tendency to recede through the jet, and ignite the gas within the box D; this breaking the wire-gauzes renders the whole imperfect, and a sudden and general explosion almost inevitable. It is, however, somewhat more safe when accompanied with Gurney's blow-pipe jet. (See Gurney.)

CLARKE'S (E. M.) ELECTROPETER. An instrument for changing rapidly the direction of electric currents.

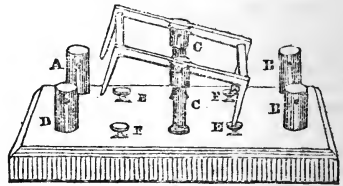

A B B D are four brass cups, screwing into, and passing through the bottom board C C; two brass pillars also screwing into, and passing through the bottom board, having slits filed in their heads, into which two moveable brass frames fit; these being connected together by two ivory rods at the ends. Four brass cups E E F F also screw into the bottom board, and pass through it; cup A is connected beneath by a wire with cups E E; cup D with F F, and cups B B with the pillars C C. Consequently the fluid entering the cup A will pass to E, then to the other E, and then up the frame, down the nearest pillar, and so on to B; upon reversing the frame so that its points dip into the other small cups, the fluid will pass from A to the nearest cup E, thence up the frame, and down the pillar C, to the farthest stud B, instead of the nearer stud as before. Mercury is put into the small cups, into which the points of the frames dip before using the instrument.

CLARKE'S (E. M.) ELECTRO-GASOMETER. An instrument for collecting and ascertaining the quantity of mixed gases, which rise from the decomposition of water by the galvanic apparatus.

A a glass vessel, having at and through the bottom of it two wires, as represented at B. C a graduated glass tube, sealed at the top, and standing over the platinum wires. D a circular piece of wood, in which A fits loosely. In the centre is a divided chamber, the two cells of which are connected by wires with the mercury cups. To use the instru-

ment; having filled the vessel A with water up to A, close the air-hole F, and invert

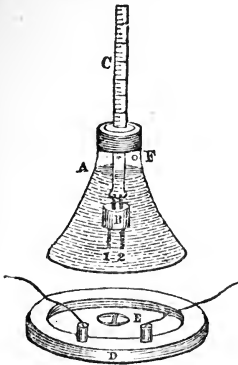

the whole that the water may flow into, and fill C; having put mercury into each division of the chamber E, and also in the mercury cups, place A in D, so that the points of the platinum wires may dip one into each of the divisions at E. The power of the battery is noted by the amount of gases given off.

CLARKE'S (U.) ELECTRO - MAGNETIC COIL MACHINE. A slight modification of Bachhoffner's coil machine, the difference being in the wheel which breaks contact, in the bundle of wires being hid, and in the compound coil being placed upright, instead of across. (See *Bachhoffner*.)

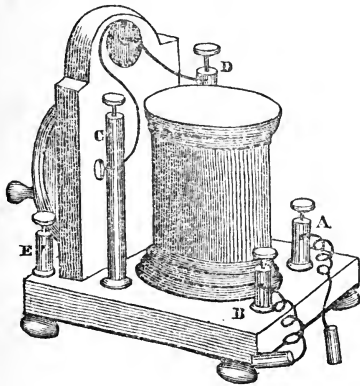

The part for breaking contact consists of a wheel made of brass, with notches cut out of the circumference, in which notches small pieces of ivory are inserted; one of the battery wires touching the spindle, or axis, of this wheel preserves its contact with the brass, but the other wire, which leans against the

rim, touches metal and ivory alternately. To the brass studs A and B are fastened the ends of the secondary wire; to this part is attached, when occasion requires, the wires to communicate the shock. The terminations of the primary coil are joined to the pillars at the back of the machine, one of which is seen at F. The wires from the battery are attached to C and D; these pillars being also attached to the back pillars.

CLARKE'S (U.) ELECTRO - MAGNETIC ENGINE. It is known that while an electric current is traversing along a wire, which is coiled over a bar of iron, that bar of iron acts like, or in fact becomes a magnet, but as soon as the contact is broken its magnetic power ceases, to be renewed again, and again broken at every change.

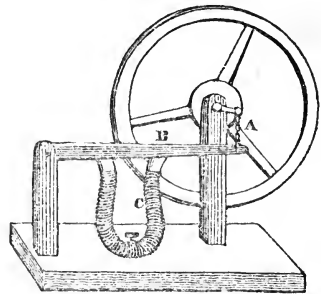

In the above cut A is a crank, attached to a fly wheel, and to a light bar of iron B. C is a temporary magnet, such as has been spoken of; if then the horse-shoe iron C be connected with an electropeter, and that with a battery, it will at one moment draw down the bar B; but the next moment let it go again, when the fly wheel being put in motion will draw it up. At the next instant, the first action is renewed, but only to be as quickly broken a second time. Thus alternately rising and falling, a rotative action is preserved in the wheel.

CLARKE'S (E. M.) MAGNETO-ELECTRIC MACHINE; or a machine to produce electrical effects from a magnet.

A is a very powerful compound horse-shoe magnet, each bar being 2 or 3 feet in its whole length. It is fastened upright to a back-board B, by means of the screw C: it is elevated slightly upon a square piece of wood at the foot. E and F are the two coils of thin covered copper wire, each consisting of about 700 yards of wire; the ends of which are soldered to the bar of iron in front of them. From the centre of this bar projects a brass spindle, which passes on one side, between the coils of the armature and the cheeks of the magnets, through the board B, and out at the back, where there is at-

tached to it a small wheel, that is worked by a cord passing the larger wheel D. The fore

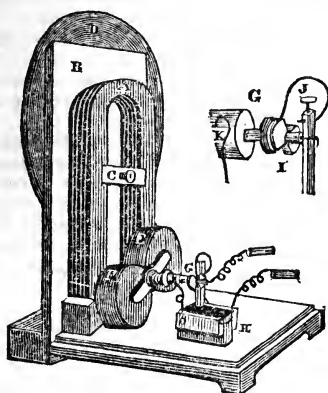

part of the spindle is terminated by a wire G, and a break piece at the end of it, and is seen of a larger size above; the spindle being marked K, the wire G, and the break piece I. J is a brass pillar, inserted into the stand, and holding on the upper end a wire, which presses against the break piece I. H is a block of wood, with a strap of brass on each side; one bearing a wire which reaches to K, the other the pillar and wire J. The circuit then will be complete, by joining the metals on each side of the block H. This may be done either by a wire, or by a pair of handles attached in a proper manner; of course any thing connecting these parts will receive the magnetic shock.

CLARKE'S (E. M.) THERMO-ELECTRO-METER. A name given by Mr. Clarke to an instrument which professes to ascertain the deflagrating, or heating power of an electric current.

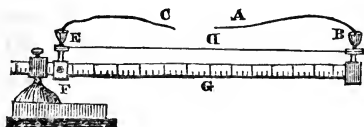

A and C are the two wires, connected with the galvanic battery, dipping into the mercury cups B and E. D is a piece of platinum wire, say the ninetieth of an inch diameter, secured at B by a small forceps; at the other end E is also a pair of forceps, insulated by a piece of ivory F; having a binding screw to press it tightly upon the ivory scale G, which may be elongated by passing it more or less through the socket of the foot

stand. It is needless to add, that the length of wire, made red hot or burned, is the measurer of power.

CLAUDE LORRAINE GLASSES. The painter Claude was accustomed to judge of the effect of different lights, such as sunset, sunrise, moonlight, &c. upon a landscape, by viewing it through an appropriately-colored glass; such glasses, therefore, as are tinted blue, red, or yellow, and adapted for this purpose, are called Claude Lorraine glasses. Spectacles are sometimes made of a corresponding nature for the use of artists.

CLAY. An earth, consisting of alumina, generally contaminated with silica, and occasionally with lime, magnesia, and various metallic oxydes, particularly those of iron. It is readily diffusible in water, forming with it a plastic mass, which may be kneaded or moulded to any shape. It concretes on becoming dry, and when burnt, assumes a state of extreme hardness, shrinking considerably in the fire, and losing its capability of becoming ductile, when mixed with water. Clays are divided into, first, fire clays, or such as become extremely hard in the fire, and remain afterwards scarcely altered by it; used for lining furnaces, making crucibles, &c. Second, common clay, used in the manufacture of bricks, tiles, and the coarser kind of pottery ware. Third, potter's or plastic clay, or pipe clay, which is very ductile, and becomes white in burning, such as is used for the common white ware, tobacco pipes, &c. Fourth, Kaolin or China clay, such as is used in the finer kind of porcelain. This kind is found not only in China, but in Saxony, France, Spain, and England, (in Cornwall.)

CLAYING, Process of. Sugar after having been boiled and purified by the sugar refiner, is poured into conical pans; these are placed with their small ends downwards, and after having somewhat cooled and drained, a thin paste of pipe clay and water is placed on the top of the sugar in the pans; the water out of this paste trickles through the mass of sugar, and carries down with it the impurities in the loaf; this process is called *claying*. Some sugar requires it to be repeated four or five times before it becomes perfectly purified.

CLEAVAGE. Those who are accustomed to polish precious stones and minerals are aware that they afford smooth surfaces only when broken in particular directions. This is the case with crystallized bodies in general. The power which they have of thus breaking is called their *cleavage*, and the particular directions in which they break, are called their *cleavage-planes*.

CLERESTORY. The upper story or row of windows in a Gothic church; also the windows in the lantern of the tower are so called.

CLEPSYDRA, or WATER CLOCK. A contrivance, of very great antiquity, to note the lapse of time, and indicate the hour by the flowing of water into or out of a vessel properly graduated. The margin shows a clepsydra of the latter kind, invented by Mr. Partington, and by which equal quantities of water are discharged in equal times. A is a cylindrical vessel to hold the water, and B a cork float on its surface, through which is passed the short leg of a narrow syphon C, which is suspended by a silk cord over a wheel D, the syphon being nearly balanced by the weight E, at the other end of the cord. Near the extremity of the long end of the syphon is fastened an index F, that points out upon a graduated scale the hour, according to the depression within the tube. It is obvious that as the float by which the syphon is supported, is always submersed to the same depth in the water, the outer leg will always remain in the same relative position to the surface: thus, the same hydrostatic pressure being preserved, the flow of water will be uniform. The water falls into a reservoir G, which forms the base of the instrument, and may be made to fall back into the tube by putting a valve between them, and inclining the instrument.

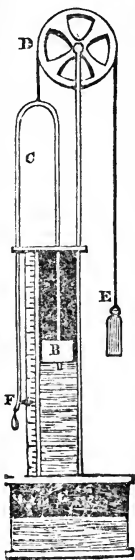

CLIMATE. The word has two meanings; one used in the older books of geography to designate certain belts of the earth, which have a reference to the length of the longest day in each belt, half an hour difference constituting different climates in the tropical regions; one hour difference was allowed between one climate and another in the temperate zones, and one month within the polar circles. This application of the term is now quite disused, and it is considered to signify the prevailing constitution of the atmosphere, relative to heat, wind, and moisture, to any region. This depends chiefly upon the latitude of the place, its elevation above the level of the sea, and its insular or continental position, in addition to its general situation on the globe.

CLINOMETER. An instrument upon the principle of the level, for measuring the dip of mineral strata.

CLOCK. An instrument for measuring and indicating time.

CLOISTERS. A quadrangular arcade of

heavy and often rich architecture, surrounded by monastic buildings, and enclosing an open space within, used formerly for the exercise of the monks.

CLOROPHANE. (See *Chlorophane*.)

CLOSE. The confines of a cathedral, usually enclosed by a wall.

CLOUD. An accumulation of the vapors in the atmosphere, so far condensed as to be visible. Clouds have various names, according to the different degrees of their fleeciness and apparent solidity; being called *cirrus*, if light and fleecy; *cumulus*, if in rounded or conical heaps; and *stratus*, if in one continued sheet. A detached and moving rain cloud is called *nimbus*.

CLOVES. A spice, which consists of the buds and young flowers of the caryophyllus aromaticus.

CLUSTERED COLUMN, rather CLUSTERED PILLAR. A pier, consisting of several pillars united.

CLYSSUS. A word formerly used to denote the vapor produced by the detonation of nitre with any inflammable substance. ••

CLUTCH, or GLAND. A piece of wood or metal with two legs, to disengage and re-engage machinery. It is represented as follows:—When the part A is drawn back, the part B is freed; when A is thrust forward so that its two arms are inserted into two holes, on the face of B, then one turns the other, and they both revolve together.

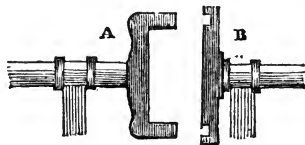

COAL. A carbonaceous substance, lying in strata at various depths beneath the surface of the earth, and extensively used for fuel, and the making of gas. In a practical point of view, coals may be divided into three kinds. First, *anthracite*, or stone coal, of which class is the Welsh and Kilkenny coal. It is chiefly used in smelting furnaces, lime-kilns, &c. Secondly, *open burning coal*, kindles quickly, makes a hot pleasant fire, but is soon consumed, and produces smoke and flame in abundance. It does not cake together, but burns to a white ash; of this kind are most of the inland counties' coals, the Scotch coals, cannel coal, &c. Thirdly, *close burning coal*, kindles quickly, makes a very hot fire, melts and cakes together; is more durable than the former kind, and burns to a brown ash; of this kind are most of the sea-borne coals, particularly those from the north, around Newcastle, &c. These kinds of coal often run into each other.

COAL GAS. The carburetted hydrogen gas, which arises from the distillation of coal. (See *Gas Works*.)

COATING, or LORICATION. The operation of covering retorts, and similar vessels, with a clayey substance, to enable them the better to bear an intense heat. A coating substance, recommended by Dr. Ure, is a soft mixture of marly earth and fresh horse-dung, kneaded together.

COBALT. A metal, which is of a reddish grey color, brittle, and difficultly fusible. It combines with oxygen in two proportions, the dark blue protoxide and the black peroxide; the former of these varies much in color. Cobalt also unites with chlorine, iodine, bromine, fluorine, sulphur, phosphorus, and cyanogen. Cobalt is not used in a metallic state, but as an oxyde, under the name of zaffre, smalt, and azure blue. Its employment is either to color glass and porcelain, which it does of a fine blue color, or as a pigment for the painter.

COBALTIC ACID. An acid only inferred to exist, because ammonia combines with the oxyde of cobalt, forming as some suppose a cobaltate of ammonia.

COBWALL. A wall built of unburnt clay, sometimes mixed with straw; common in the south and west of the kingdom, as walls for inclosures, cottages, &c.

COCCINELLIN. The name given by Dr. John to the red coloring matter of cochineal.

COCHINEAL. A fine scarlet color, produced from a small insect of the beetle kind, common in Mexico, which lives upon the cactus opuntia, or Indian fig cactus, enveloping itself during a great part of its existence in a fine cottony down or web. Its coloring principle is extracted by grinding the insect, and steeping it in water, in which it is very soluble. Alumina rapidly combines with it, rendering the water colorless, and itself becoming of a fine lake, crimson, or violet, according to the temperature of the solution acted upon. The salts of tin also rapidly act upon the color, forming, according to the salt used, a violet or fine carmine color. Cochineal is used for dyeing scarlet and crimson colors, and by the painter, under the name of carmine, as the finest of all red colors.

COCHLEAR. The same as Archimedes screw; a water engine.

COCK. An instrument for permitting or arresting the flow of a liquid at pleasure. It is an article too well known to need description.

COCKLE. The body or fire-place of an air stove is sometimes so called.

COCKLING. Anything becoming entangled.

COCOON. The bag of silk made by the silkworm. A good cocoon weighs without the worm about 4 grains, and usually contains a fibre of silk from 3 to 400 yards in length.

CODEIA. An alkaloid, discovered by Rebiguet, in 1832, in the muriate of morphia.

CODDRINGTON LENS. A small sphere of glass, with its equatorial parts ground away, that it may thus at the same time magnify, and yet be corrected for spherical aberration.

CO-EFFICIENT. In algebra, are numbers or letters prefixed to other letters or unknown quantities, into which they are supposed to be multiplied; thus in the quantities $ab, cx^2, 2d, \&c.$, the $a, c,$ and $2,$ are the co-efficients to the quantities $b, x^2,$ and $d.$

COFFER. A deep panel in a ceiling.

COFFER DAM. A term applied by engineers to denote the inclosures formed for laying the foundation of piers and other works in water, to exclude the surrounding fluid, and thus forming a protection both to the work and the workmen. Cofferdams are usually made of two circles of piles driven in at some distance from each other, and clay rammed between them; the water being afterwards pumped out of the circle leaves an empty space for the pier to be built in.

COFFER WORKS. In masonry, are rubble walls faced with free-stone.

Cog. The tooth of a wheel.

Cog, Hunting. In a cogged wheel if the number of teeth were exactly a multiple of the number of pallets which work in it, each pallet would, in every revolution, strike the same tooth or cog, and an unevenness of wear be likely to ensue; to prevent this the cogged wheel is made with one cog more than the multiple; this extra cog is called the hunting cog.

COG WHEEL. Any wheel furnished with cogs or teeth around its circumference—distinguished from a toothed wheel by the cogs being of a different material.

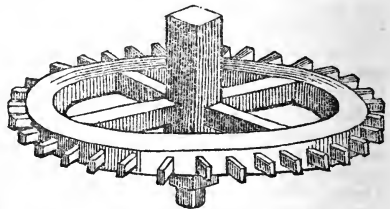

COIL, ELECTRO-MAGNETIC MACHINE. A machine which derives its chief properties from the electric fluid being made to pass along a coil of wire. Full descriptions of several machines of this kind will be found under *Bachhoffner, Clarke, Bird, Sturgeon, &c.*

COIL, CALLAN'S. (See *Callan*.)

COHESION. (See *Attraction*.)

COHOBATE. To re-distil a liquid; that is, to collect the products of distillation and pour it back again into the still, that it may

rise a second time of a stronger quality. Creosote and numerous oils are stronger by a re-distillation from the original matter in the still.

COKE. Pitcoal burnt to a charcoal, that is burnt without contact with the air, so as to have its gaseous and volatile particles burnt or driven from it.

COLCOTHAR OF VITRIOL, Jeweller's Rouge or Plate Powder, is the brown red peroxyde of iron; it may be made by adding solution of soda to the solution of sulphate of iron or copperas, washing, drying, and calcining the powder with a gentle heat in shallow vessels, till it assumes a deep brown red color.

COLD. The privation of heat.

COLLAR OF A STEAM CYLINDER, PUMP, &c., is a plate of metal screwed down upon the stuffing box, with a hole to allow the piston to pass through it.

COLLIMATION, LINE OF. On a telescope is a line passing through the intersection of those wires that are fixed in the focus, and the centre of the object glass.

COLLISION. The meeting and mutual striking of two or more bodies, one of which at least is in motion.

COLOCYNTIN. The peculiar principle of colocintida.

COLONNADE. A range of open columns, detached from a wall, and supporting an entablature. When in the front of a building, it is called a *portico*; when entirely surrounding a building it is a *peristyle*; and when double or treble it is a *polystyle*. Colonnades also often support terraces, galleries, &c. The colonnade in Regent Street is one of the most extensive and beautiful of modern times, but is far surpassed by the Greeks in numerous of their edifices, and by the Romans, especially in the splendid remains of Palmyra.

COLOPHONY. Black rosin; the residuum of the distillation of turpentine.

COLOPHONIC ACID. An acid existing in colophony.

COLOSSUS. Applied to any figure twice or more than twice as large as life; also to any building, or part of ditto, of immense size.

COLOR, is that property in bodies, which, when acted upon by light, impresses the mind, through the agency of our sight, with those sensations which we denominate color. The light of the sun, which seems perfectly homogenous and white, is capable of being separated into seven tints or colors, called red, orange, yellow, green, blue, purple and violet, as is proved by holding a prism before the sun's light, when these colors will be manifested on a white paper, held so that the ray of light is reflected on it, or as we witness naturally in the rainbow. These colors are truly but three in number, red, yellow,

and blue or violet; the green, orange and purple being but a combination of the other three, as may be proved by mixing them artificially; red and yellow forming orange, yellow and blue forming green. The colors of natural objects, of trees, flowers, minerals, and factitious products, do not always accord with the colors of light; inasmuch as there are numerous reds, blues, and yellows, thus the orange, green, and purple colors vary in like degree; besides which, if a substance be so constituted as to absorb all the rays of light, it will appear black; if it absorb none of the rays, it will constitute white; if it absorb all the rays but one, it will appear of that one color: thus by the aid of the various reds, blues and yellows, together with black and white, we are enabled to produce, artificially, all tints whatever. Brown is produced by a combination of red, black and yellow; chocolate, or claret color, red and black; olive, green and black; maroon, purple and black; salmon color, pink, peach color, flesh color, &c., red and white; cream color and primrose, yellow and white; sage green, green and white; and so on for other colors. For other properties of colors, (see *Accidental, Adjective, Substantive, &c.*)

COLORING MATTER. That which produces the color of material substances, as indigo is the coloring matter of the indigo plant. Sap green, the coloring matter of the buckthorn berry. Dyes are all coloring matters.

COLUMBATES. Combinations of the columbic acid, with various bases.

COLUMBIC ACID. A combination of the metal columbium with oxygen.

COLUMBIN. A peculiar principle in columbo root.

COLUMBIUM. A peculiar metal extracted from a rare mineral brought from Connecticut. It is also called *tantalium*, from the mineral tantalite, found in Sweden. It has hitherto no application in the arts. It combines with oxygen in two proportions; in one forming an oxyde, in the other an acid, called the *columbic acid*.

COLUMN. A round tapering pillar, composed of a base, (except in the Greek Doric,) a shaft, and a capital, over which is an abacus. The word column is, in its true meaning, confined to designate the pillars of classical buildings only, or such as are made of certain exact pre-arranged proportions, and attended by only certain ornaments. All other supports for buildings varying from these standards are properly pillars, or, if square and unornamented, piers. Each of the Grecian and Roman orders required columns of different altitudes and dimensions, from the low stature of those of the massive Doric to the lofty and slender Corinthian. The following cut will show the appearance and relative dimensions of the five orders;

greater details of them will be found under the names of those orders.

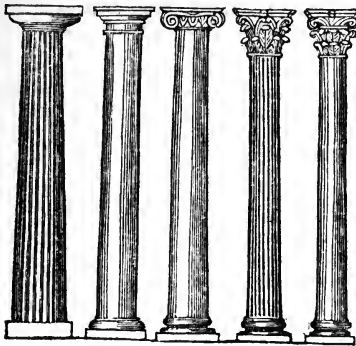

COLUMN, Electric. (See *De Luc.*)

COMBINATION. The intimate union of the particles of different substances by chemical attraction, so as to form a compound possessed of new and peculiar properties.

COMBINATIONS. In mathematics, denote the different collections that may be made out of a certain number of articles, taking a certain number at a time, without regard to the order in which they are to be arranged.

COLURES. In astronomy and geography, are two great circles, supposed to intersect each other at right angles in the poles of the world, and to pass through the solstitial and equinoctial parts of the ecliptic; that which passes through the former point being called the *solstitial colure*, and the other the *equinoctial colure*.

COMBUSTIBLE. Any substance capable of being consumed by fire, giving out, during its destruction, both light and heat.

COMBUSTION. The act of burning, and which results from a sudden chemical change in the combustible body, most of its solid particles becoming changed into gaseous, whereby its aggregation is destroyed, and new combinations are formed; thus dry wood, when burnt, no longer exists as wood, still not a particle of it is destroyed during its combustion. Oxygen, hydrogen, and carbonic acid gas fly off, the latter floats in the atmosphere, or may be absorbed by a proper apparatus: part of the oxygen exists in the carbonic acid gas, the rest unites with the hydrogen and forms water, while scoria or ashes remain unconsumed. All these being collected and weighed, will exactly agree with the original weight of the wood, so that nothing is lost, but the particles of bodies are merely compelled to form new combinations.

COMBUSTION, Supporters of. Such substances as will support combustion; these

are various of the gaseous elements, particularly oxygen.

COMETS. Those heavenly bodies which revolve around the sun in long, elliptic orbits, appearing at uncertain times, and which, during the time of their appearance, have a motion in some respects similar to that of the planets. The courses of comets, however, are not confined to any particular angle, relative to the sun's poles, as the planets are; nor yet are they all rotative in the same direction, some being direct, others retrograde. Comets, according to the circumstances in which they are seen, are called *bearded* or *tailed*. They are also divided into the following parts:—The *nucleus*, or thick part of the comet, which is thought to be of the same nature as the planets. The *head*, or light, which surrounds this nucleus. The *coma*, which is a still fainter light around the head; and the *tail*, or stream of light, which follows the comet. The following cut shows a comet in different parts of its eccentric orbit:—

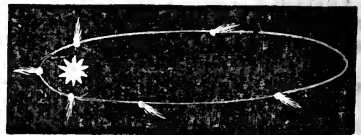

COMMENSURABLE. Among geometers, an appellation given to such quantities as are measured by one and the same common measure, such as 8 and 12, both of which may be divided by 4.

COMMISSURE. The joint between two stones in masonry.

COMMON ELECTRICITY, is that free kind of electricity, which is produced by friction, as contra-distinguished from galvanic, magnetic, and thermo-electricity.

COMMON MEASURE, or DIVISOR, is that number which will divide two other numbers, without leaving a remainder; 2, 3, 4, and 6, are all common measures of 12 and 18; and 6 is the *greatest* common measure of those numbers, because no other larger than it will divide them both equally.

COMMON PITCH. A roof is so called when the rafters are about three-quarters the width of the building.

COMMUTATION. In astronomy, the angle of commutation is the distance between the sun's true place, seen from the earth, and the place of a planet, reduced to the ecliptic, or in common language it may be called the apparent difference of longitude between the sun and a planet.

COMPARTITION. The division of the ground plan of a building into its various compartments.

COMPARTMENT. One portion of an extended subject, or edifice. For example, one arch is a compartment of an arcade; the choir is one compartment of a cathedral. The term is particularly applicable when chosen as a sample of the rest of the edifice.

COMPASS, The Mariner's. A magnetic instrument, used at sea to ascertain the bearing of places, the course of the ship, the position of objects, &c. It consists of a brass box, bearing on a central pin or pivot within, a magnetic needle, which either turns round upon the surface of a graduated card, (see below;) or else it is so fastened to the card that they both turn together. In the first case, the degrees upon the card, which are beneath the needle, indicate its quantity and direction of motion: in the other case, in which the card and needle are attached to each other, a hand or stud upon the box is applied to the same purpose, by showing how much of the card has passed under it.

COMPASS, Points of the, are the thirty-two principal divisions on the card of a magnetic compass; each of which has a particular denomination, either that of the cardinal points, east, west, north, and south, or composed of various combinations of them, as follows:—

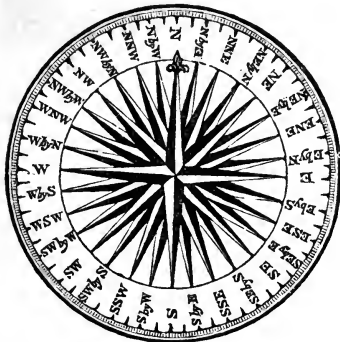

Each of these points contains $11^{\circ} 15'$, and is again divided into quarter points. The points of the compass are also called *rhumbs*.

COMPASS DIALS. Small pocket sun dials, fitted to a box carrying a magnetic needle; in order to place them in the meridian at the time of observation.

COMPASS, Variation of. The magnetic pole to which magnetized needles turn does not coincide with the pole of the earth's axis, therefore the mariner's compass does not point north and south, relative to the earth's motion and position; as it is the object of the mariner, however, to ascertain this very accurately, he is obliged to make a due allowance for this variation of the compass, and which in high latitudes is very considerable.

COMPASSES. A mathematical instrument, for describing circles, measuring and dividing lines, &c. There are numerous kinds of compasses, of which the principal are the *beam* compasses and calipers, already described. The *German* compasses A, which have their legs a little bent outwards near the top, so that when shut the points only meet. *Hair* compasses are so constructed withinside, by a small adjusting screw to one of the legs, as to take an extent even to a hair's breadth. *Spring* compasses, such as are expanded by a spring, and closed by a screw B. *Triangular* compasses are made with three legs, to measure triangles, C. *Bow* compasses are of a small size, and shut up in a bow or hoop. *Proportional* compasses are those in which the joint lies, not at the end of the legs, but is moveable up and down, so that it may be set at any distance from either end, and consequently a distance measured by the points at one end, is diminished or enlarged in a proportional degree at the other, D.

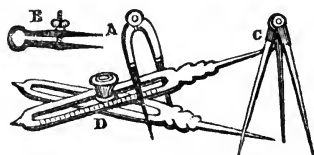

COMPASSES, Elliptic. (See *Trammel*.)

COMPASS HEADED. An arch with a circular head, whether it be of a semi-circular, segmental, or horse-shoe-like form.

COMPASS WINDOW. Synonymous with bow window.

COMPASS ROOF. Synonymous with *span* roof; that is, a roof which extends from one wall to the opposite, and the rafters of which meet in the centre between them.

COMPENSATION BALANCE. (See *Arnold*.)

COMPENSATION BARS. Bars made of two or more metals, of such a nature that the expansion of one metal shall counteract the expansion of another. Such bars are used in the balances of chronometers, in pendulums, &c., in order to produce perfect equality of motion, notwithstanding changes of temperature.

COMPLEMENT. A portion requisite to make up a certain quantity; for example, the complement of an angle is the number of degrees which must be added to it to make up 90° . The complement of a logarithm is what it wants to make it up to $10\cdot000000$; thus the complement of $8\cdot250139$ is $1\cdot749861$. Complement, in astronomy, denotes the distance of a star from the zenith, and is the same as the co-latitude, or the complement of the latitude of it. The complements of a parallelogram are the two smaller parallelograms made by drawing two right lines

through a point in the diagonal, and parallel to the sides of the parallelogram. These complements are always equal to each other. In the following cut, A and B are the complements of the parallelogram D C E F.

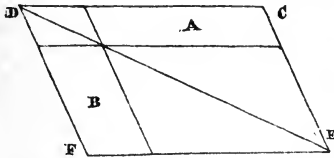

COMPOSITE. An order of architecture, composed of the Ionic and Corinthian, the capital uniting the leaves of the one with the heavier volute and sculptured mouldings of the other. This order was intended to be more delicate than the Corinthian, but the corona being very heavy, the modillions square, and the entablature generally overloaded with ornament, it becomes even more massive. The base and shaft of the column scarcely differ from the Corinthian, except in the shaft being half a module longer; the capital shows the chief differences between them. The volute is larger, and usually rests upon the second row of leaves, and the leaf which tops it grows also upon its side, while a second small leaf leans on the angle of it. The flower in the centre of the acabus consists of two rows of leaves; the smaller volute of the Corinthian are changed into leafy tendrils, bearing a flower, immediately above which is a sculptured egg, and tongue moulding. The chief buildings of this order are the baths of Diocletian, the arch of Titus, the temple of Bacchus, and the arch of Septimius, all at Rome.

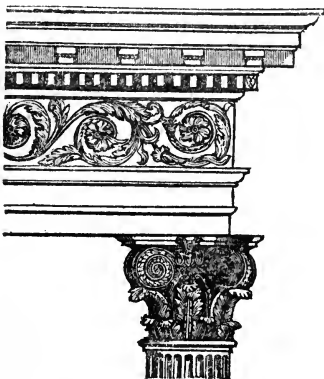

COMPOSING STICK. An iron or brass frame, held in the left hand of the compositor, in order to deposit and retain, for a

time, the types as he takes them from the cases. It may be adjusted to any width, by means of a moveable arm and a screw, which retains this arm in any position in which it may be placed.

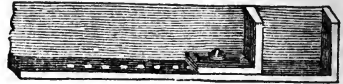

COMPOSITOR. A workman in a printing office who arranges the types in proper order, ready for the pressman; that is, for him who takes the impression of them on paper.

COMPOSITE ARCH. The pointed or lancet arch.

COMPOSITE NUMBER, is that which is produced by the multiplication of two other numbers. For example, 24 and 36 are composite numbers; the first being produced by the multiplication of 4 and 6, the other of 3 and 12.

COMPOSITION. The disposition or arrangement of the various parts of a design, so as to produce an harmonious whole.

COMPOSITION OF FORCES, is the finding the quantity and direction of a single force, which is equivalent to two or more forces, acting each differently, and of which the quantity and direction are given.

COMPOSITION OF FORCES, *Ma hine to explain.* The following machine will prove how two forces conspire to produce one motion, and that intermediate between them.

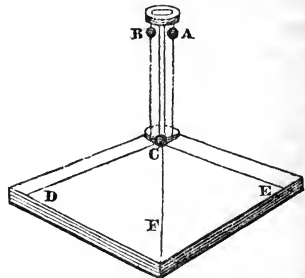

At bottom is a square frame or table; at one corner rises a slender rod, and on each side of it an upright wire, bearing a ball, which by a hole is made to slip easily up and down. In the centre beneath is a third ball, resting loosely on the table. If the ball A falls, it would strike the ball C, and drive it to D; if B falls, it would drive it to E, but if both A and B are suffered to fall at exactly the same time, the ball C would obey the impulse of both at once, and take an intermediate course; that is, be propelled across the board to E.

COMPOUND ADDITION, SUBTRACTION, MULTIPLICATION, and DIVISION. Those

rules of arithmetic when applied to compound quantities, or quantities of different denominations.

COMPOUND ARCH, or RECESSED ARCH. One arch receding within another.

COMPOUND MICROSCOPES, are such as have two sets of glasses. Single microscopes consist of a single glass or lens, or of two lenses, acting as a single one.

COMPOUND MOTION, is that which arises from the effect of several conspiring forces.

COMPOUND PIER. Synonymous with clustered.

COMPOUND QUANTITIES, in algebra, are such as are linked together by the signs + or - ; as $a + b$, $c - d$, $xy + ab$, are compound quantities. These are distinguished into *binomials*, *trinomials*, &c., according to the number of the quantities which compose them.

COMPRESSIBILITY. That quality of a body by which it yields to the pressure of another body or force, so as to be brought into a narrower compass.

COMPUTATION. Calculation or reckoning.

CONCAMERATE. To arch over.

CONCATENATE. To link together.

CONCAVE. A hollow curved surface, like the inside of a cup.

CONCAVE LENS. A lens which has one side flat, the other slightly hollowed out, A. A *double concave lens* has both sides hollowed, B. A *concavo-convex lens* is concave on one side, and convex on the other, C, the centre part being thinner than towards the edges. Objects viewed through concave glasses appear more distant, or diminished in size.



CONCAVITY. The cavity within hollow bodies.

CONCENTRIC. Having a common centre ; such as concentric circles, ellipses, &c.

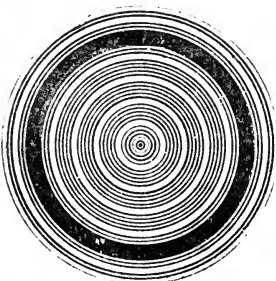

CONCENTRIC ENGINE. (See *Steam Wheel*.)

CONCHA. The concave ribless surface of a vault.

CONCHOID. The name of a particular mathematical curve, which may be made as follows :—

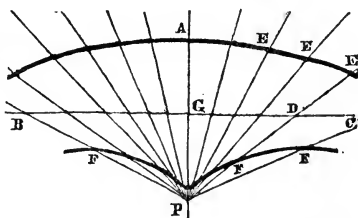

A P and B C, being two lines intersecting at right angles ; from P, draw a number of other lines P.F D E, &c., on which take always $DE = DF = AG$: so shall the curved line drawn through all the points E E E be the first conchoid, or the conchoid of Nicomedes ; and the curve that may be drawn through all the other points F F F is called the second conchoid.

CONCRETE. A mixture of lime and sand or small pebbles, which when mixed together, concrete or harden into a solid rocky mass. It is used for the foundation of buildings, paved roads, &c.

CONCRETION. The growing together, or hardening of any thing.

CONCRETE NUMBERS, are such as are used to designate any particular thing, as 3 pounds, &c., in opposition to absolute numbers, (which see.)

CONCRETE OILS. Such as are in the usual state of the atmosphere of a congealed, tallow-like consistence, such as the oils of the palm, the cocoa nut, &c.

CONDENSATION. The art by which a body is rendered more dense or heavy : it is applied chiefly to the changing of vapour into a liquid, as in distillation and similar arts.

CONDENSER. The name of any vessel in which a vapour is condensed by cold into a liquid. Those vessels in which a hot liquid is changed to one that is cold is called a *refrigerator*. The worm belonging to a still is both, as the vapour of the spirit distilled is first changed by cold into a liquid, and this, hot at first, becomes in its descent through the worm gradually cooled.

CONDENSER OF THE STEAM ENGINE, is a vessel attached to the steam cylinder, and between it and the air-pump. The position and action of the condenser, as well as of the neighbouring parts, will be understood by the following cut, which is a part of Watt's steam engine.

A A A is a section of the cistern, containing cold water. B the eduction pipe from the steam cylinder. C the condenser, which

communicates by the clack valve D, situated in a pipe at bottom, with the air-pump E, (this is of the common suction kind, but the piston is furnished with two valves.) The

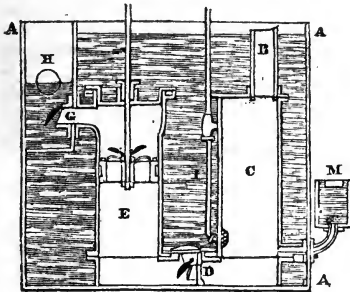

valve G opens into the hot well H, and the opening at H is the end of a pipe, that allows the surplus hot water to run off; the remainder being pumped into the boiler. The pipe I leads to the cold water cistern at top, and by an injection cock and a rose into the condenser, near the bottom. Before the engine is set a-going, the injection cock is shut, and steam is admitted to the cylinder, which passing down through the pipe B into the condenser fills it; there being no cold water yet admitted, it finds no other escape than through the valve M, which is covered with a little water; the air previously in C passes out at the same time. The injection cock is then opened, and the steam being condensed, the piston begins to move. The piston rod and air pump rod rise and fall together, being attached to the same end of the beam. When the piston rises, the valves in the piston of the air pump will be shut, and all the air and water above it, lifted into the well H at the same time, owing to the vacuum formed beneath at E. The valve D will open, and let out from the condenser all the air and water contained in it. The downward action of the piston rod will close the valves G and H, and open those in the air pump piston which was to admit the water above them, ready to be discharged at the next stroke of the engine, which the injection pipe again opening produces a second condensation. The condenser and air pump of an engine should be each about one-eighth the capacity of the steam cylinder.

CONDENSER PUMP. Another name for the air pump which is attached to the condenser of the steam engine, as described under condenser, and shown at letter E.

CONDENSER GAUGE. A tube of glass, 32 inches long, open at both ends; the upper end being fixed to the condenser, the lower end dipping into mercury. It is to

ascertain the degree of exhaustion within the condenser. If there were a perfect vacuum within the condenser, the atmosphere would press the mercury up the tube to a height of from 28 to 32 inches. This degree of vacuum, however, is never attained in practice.

CONDENSER, Volta's Electrical, is represented as follows; and is attached, as is usual with it, to a gold-leaf electrometer. It consists of two brass plates, one connected with the cap of the electrometer; the other supported on a glass pillar. The use of the instrument is to render apparent such portions of electricity, as are too weak to be indicated by the electrometer only.

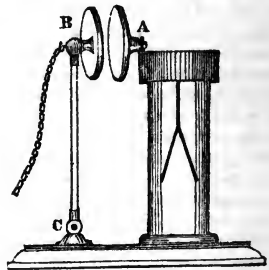

CONDENSING SYRINGE. An instrument of the nature of a squirt, furnished with a handle, moving a solid piston B airtightly in a cylindrical barrel, which barrel is furnished with a valve at the foot, opening outwards A; and either a small hole near the top of the barrel C; or else the piston, instead of being solid, is perforated, and has a valve also opening downwards. It will be evident, that working the handle up and down will alternately fill the barrel with air from the upper part, and condense it into any vessel attached to the screw at the foot. By reserving the valves it forms an exhausting syringe.

CONDENSING SYRINGE, is also an instrument for procuring an instantaneous light, by means of the condensation of air. A is a solid piston, with a small piece of tinder at the end of it. B is a strong barrel or tube, with a hole into which the piston fits, but without any hole at one end, and no part of the instrument is furnished with a valve. Upon forcing down the piston quickly, the air within the tube is rapidly condensed, and the condensation occasions so great an evolution of heat as to light the tinder.

CONDUCTOR FOR LIGHTNING. (See *Lightning.*)

CONDUCTORS OF CALORIC, are bodies, which when heated at one part, communicate the effects to another part. This is the case with most natural bodies, but some have that power in a greater degree than others; thus metals conduct caloric rapidly; wood but slowly; and glass still more slowly.

CONDUCTORS OF ELECTRICITY. Such substances as conduct the electric fluid along their surface. The principal of these, arranged according to their degree of conducting power, are as follows:—The metals, charcoal, black lead, acids, ores, animal fluids, water, snow, living vegetables, and animals, flame, smoke, steam, salts, rarefied air, vapor of alcohol and ether, earths and stones, in their natural state. Almost all other bodies are non-conductors, or electrics.

CONDUCTOR, Prime. That part of an electrical machine, which collects and retains the electric fluid, as it passes from the cylinder, or plate of glass. The following cut shows the prime conductor of the common cylinder machine: it is supposed to be placed with one end of it towards the glass. This end is furnished with several points to collect the fluid, while the opposite end is terminated by a ball, upon which various apparatus may be attached. It is necessary that all prime conductors should be supported upon a glass pillar.

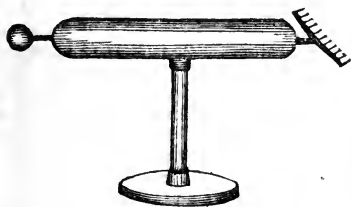

CONGE. Synonymous with apophyge.

CONGELATION. The transition of a body from a liquid to a solid state, in consequence of an abstraction of heat, as water congeals into ice.

CONE. A solid body, having a circular base, and its other extremity terminated in a single point, or vertex. Cones are either right or oblique; a right cone is that in which the apex is exactly over the centre of the base, as A. All other cones are called oblique, as B.

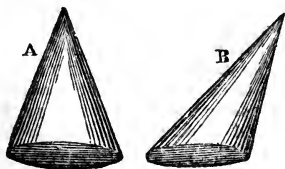

Cones may be either right, acute, or obtuse-angled, according to the magnitude of the angle of the vertex.

CONE OF RAYS. In optics, the rays of light which are thrown off from a luminous point, and intercepted by a lens, or mirror; also, those which proceed from a lens, or mirror, to its focus, and from that focus beyond.

CONE, DOUBLE. A simple mechanical experiment, to show that although it is a natural law that the centre of gravity of a body always tends to, and endeavours to obtain the lowest station, yet there may be cases in which it *appears* to roll upwards.



The double cone rests upon the two sides of a sloping railway; if the cone be placed at the narrow end of this, it will roll towards the other, and as the other is the higher end, the cone appears to roll upwards; though upon observing the height of the apex at each end, at the beginning and end of its course, it will be seen that in reality it rolls downwards; the centre of gravity being situated in the axis.

CONGRIES. A collection or heap of several bodies, collected into one mass or aggregate.

CONGRUITY. In geometry, the same as identity or perfect agreement of lines, surfaces, &c. with each other, in direction, size, &c.

CONICAL. Any thing formed like a cone.

CONICAL PENDULUM. (See *Governor*.)

CONICAL WHEELS. (See *Bevel Wheels*.)

CONICAL VALVE. A valve, as represented in the margin, of a conical form, lifting up and down when in action; fitting when down into a socket of the same shape, and kept in its position, by means of a pin which passes through it. One or other end of the pin is often made to pass through a hole made in a cross stay; at other times a weight attached below serves to keep it perpendicular. In the cut both these contrivances are shown.

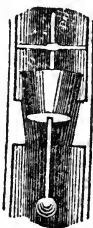

CONES, or CONIC SECTIONS. That part of mathematics which treats of the properties, proportions, and measurements of the cone; and also those figures and solids which are produced by cutting the cone in various directions. In cutting a cone, there are truly five sections: viz., a triangle, circle, ellipse, parabola, and hyperbola, yet only the three latter are peculiar to the cone; and, there-

fore, these alone are usually denominated conic sections. The *triangle* is seen whenever a plane passes through the apex and any part of the base, as at A. The *circle* is a transverse section, cut parallel to the base, as B. The *ellipse* is a transverse section cut through both sides obliquely with the base as C. If the plane pass across from one side to the base, and parallel to the other side, it will be a *parabola*, as D; but if the plane cutting the side and base, be perpendicular to the base, the part cut off is a *hyperbola*, as E.

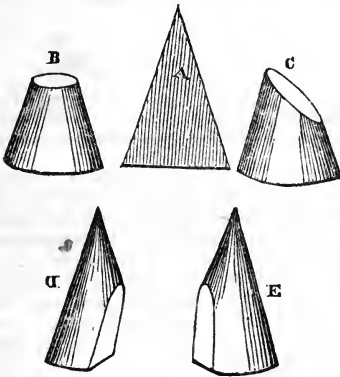

CONJUNCTION. In astronomy, is the meeting of two or more stars in the same sign of the zodiac. Conjunction may be considered true or apparent. When the two bodies meet in the same point of both longitude and latitude, the conjunction is *true*. When they agree in longitude, but differ in latitude, the conjunction is only *apparent*. Grand conjunctions are when two or more planets are seen together.

CONNECTING ROD. The rod which joins the beam of a steam engine to the crank of the fly wheel, or generally any rod or bar of iron which unites one part of machinery to another.

CONOID. A solid figure, generated by the revolution of any conic section about its axis, and hence it receives particular denominations, according to the section from which it is produced, as elliptical conoid, parabolic conoid, &c.

CONSECTARY. The same as corollary.

CONSEQUENT. The latter of two terms of a ratio, or that to which the antecedent is referred and compared; thus, in the ratio $a : b$, b is the consequent, and a the antecedent.

CONSEQUENTIA. In astronomy, the real or apparent motion of a planet, or comet, when it is moving from west to east, or according to the order of the signs; and is thus opposed to antecedentia, which denotes a contrary motion.

CONSISTENT BODIES. An old philosophical term for solid.

CONSOLE. An ornament, cut upon the keystone of an arch, which projects, and sometimes is made to support a figure, vase, or other object; also a bracket for the support of a canopy, balcony, &c. (See *Corbel* and *Truss*.)

CONSPIRING FORCES. Various forces combined into one, and therefore all acting to produce the same effect.

CONSTANT GALVANIC BATTERY. (See *Daniell*.)

CONSTELLATION. An assemblage of stars, expressed and represented under the name and figure of some animal, or other emblem.

CONSTRUCTION OF EQUATIONS, &c. The finding the roots of equations by means of geometry; so also in algebra, a geometrical construction of any given triangle will show, by mechanical measurement alone, the dimensions of those parts which are not known otherwise than by mathematical calculation.

CONTACT. The relative state of two things that touch, but do not enter into each other; for example, the contact of two globes, or circles, is in a single point.

CONTENT. A term commonly used to denote the surface or solidity of bodies, so that to find the content of a body is to find its capacity, or its measurement of surface.

CONTIGUOUS ANGLE. (See *Angle*.)

CONTINUAL PROPORTIONALS. Numbers, or quantities, that increase, or decrease, by an equal ratio as 1, 2, 4, 8, 16, 32, are continual proportionals.

CONTINUED PROPORTION, is that in which the consequent of the first ratio is the same as the antecedent of the second; thus $2 : 6 :: 6 : 18$ is a continued proportion.

CONTINUITY. An uninterrupted connection.

CONTINUITY. Law of, is that by which variable quantities, passing from one magnitude to another, pass through all the intermediate magnitudes without passing over any of them abruptly. Thus the distances of bodies can never be changed without their passing through all the intermediate distances; so also no body becomes more or less dense without passing through all the intermediate degrees of density, &c.

CONTOUR. The outline, or general periphery of any figure.

CONTRACTILE FORCES. Forces which diminish.

CONTRACTION. The diminishing the size of a body, either by pressure, by cold, or by chemical action.

CONTRA-HARMONICAL PROPORTION, is, when of three terms, the difference of the first and second is to the difference of the second and third, as the third is to the first.

CONTRAMURE. In fortification, an external wall built about the walls of a city.

CONSTANT QUANTITIES. In algebra, those whose values are known, or which remain constantly the same.

CONTRARY FLEXURE, POINT OF. The point in which two curves meet, that have the convexity of the one, and the concavity of the other, on the same side of the line, as is seen in the cima, or ogee.

CONTRATE WHEEL. (See *Crown Wheel*.)

CONVERGENT. The tendency of different things, coming from different directions, to unite in a single point. It is also sometimes used to denote the approximate value of a thing, or quantity.

CONVERSE. In mathematics, the same as *reverse*.

CONVEX. Round, curved, or projecting outwards, as the outside of a globular body.

CONVEX AND CONCAVE SCREW. (See *Screw*.)

CONVEX LENS, OR MIRROR. That which is bowed or curved outwards; if one side only of a lens be convex, and the other flat, it is called a plano-convex lens; if both be curved outwards, it is a double-convex lens.



Lenses of this kind converge the rays of light and heat, and therefore magnify the object seen through them. They are called also burning glasses and magnifying glasses.

CONVEXITY. The exterior or convex surface of any thing.

COOLER. A large shallow vessel, in which worts are rapidly cooled in the brewery. Were these not used, the wort would most probably enter at once into the acetous, instead of the vinous fermentation, and becoming vinegar rather than beer.

COOPER'S LAMP FURNACE. A lamp which is made of an elongated form, and is furnished with two rows of broad wicks, the whole or part of which may be lighted at once. Professor Faraday recommends this simple furnace as valuable for the heating of tubes, or any long and narrow vessel. Near the ends are two twisted wires, for the support of the tube to be heated.

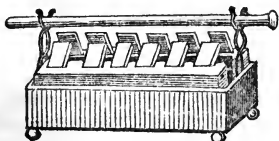

COOPER'S MERCURIAL TUBE. A small instrument to supply the place of a mercurial trough. It consists of a bent tube, closed at top, open at the foot, supported in any manner which may be convenient, and filled previous to use with mercury. The open end is then connected with a retort, or alembic, which is giving off the gas to be collected. The gas rises up through the mercury, and occupies the upper arm of the tube, while the mercury which is displaced drops into a dish put underneath to catch it.

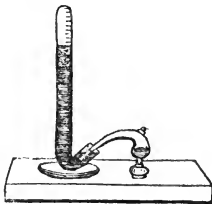

CO-ORDINATES. In the theory of curves signify any absciss, and its corresponding ordinate.

COPAL. A resin, the produce of three or four different trees. It occurs in irregular lumps, of various forms and sizes. It is without taste or smell, from a transparent white to a brown color: it is scarcely soluble in alcohol alone, unless by long-continued heat: it is soluble in ether; in alcohol when mixed with camphor; still more so in alcohol mixed with caoutchoucine, and by particular management in naphtha and the oil of turpentine.

COPAL VARNISH. This hard, clear, and imperishable varnish, which is used so much for the bodies of carriages, cabinet work, &c. may be made as follows:—Take hard copal 300 parts, drying linseed, or nut oil, from 125 to 250 parts, spirits of turpentine 500. These three substances are to be put in three separate vessels. The copal is to be fused, the drying oil heated nearly to boiling, and added by a small portion at a time to the copal. When this combination is made, and the heat a little abated, the essence of turpentine, likewise previously heated, is to be introduced by degrees. When cooled down to about the 130th degree of Fahr., it may be strained through a filter. This varnish improves by keeping.

COPERNICAN SYSTEM OF PLANETARY MOTION, is that system in which the sun is supposed at rest, and the earth and other planets to revolve about him as a centre, while the moon, and other satellites, revolve about their respective primaries in like manner.

The heavens and stars are here supposed at rest, and that diurnal motion that they appear to have from east to west is imputed

to the earth's rotation on its axis from west to east. This system, which we now know to be the true one of the universe, was known to many of the ancients, particularly Pythagoras, and therefore is sometimes called the Pythagorean, after his name; yet as it was more fully explained and completed by Copernicus—the appellation of Copernican is now more frequently employed.

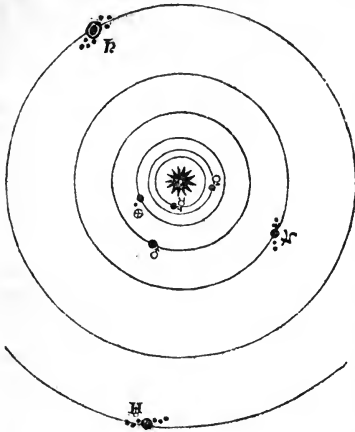

COPING, or CAPPING. The covering course of a wall, or buttress, mostly projecting beyond the general surface to throw off the wet.

COPIVI, OIL AND BALSAM OF. The resinous exudation from several species of the copaiifera is commonly called the balsam of copivi, or copaiva. If this be distilled, a fragrant volatile oil passes over, very much resembling the oil of lemon, though of less agreeable fragrance.

COPPER. A metal of a reddish brown color, hard, very malleable, sonorous, of considerable tenacity, and capable of a high polish, though soon tarnishing afterwards. There are two oxydes; the black or deutoxyde, and the orange or protoxyde. Copper unites with chlorine in two proportions; with iodine, phosphorus, sulphur, &c. Its solutions in the acids produce often very fine colored pigments. Copper in all its combinations is poisonous: it is used, not only in its metallic uncombined state, for numberless vessels; but is a component of many alloys, such as bell metal, brass, &c.

COPPERAS. Sulphate of iron: It is chiefly used as one of the ingredients of ink and black dyes.

CONIA, or CONICINE. The active principle peculiar to hemlock.

COPPER-PLATE. Artists understand by this term a sheet of copper, flattened, smoothed, and polished, ready for the engraver. The

preparation of copper-plates is very simple; the sheet of copper is first cleaned and examined for imperfections, if none appear it is fit for the purpose. It is then beaten or rolled, afterwards cut into proper sizes; ground on the surface, first with emery of different degrees of fineness, then with a hone stone or snake stone, and finally with charcoal and oil; when thus polished the edges are planed, and the plate is fit for use.

COPPER-PLATE ENGRAVING. (See *Engraving*.)

COPPER-PLATE PRINTING. The printing from engraved plates, whether of copper, steel, pewter, or other metal, indicating a style of printing which is equally applicable to any metallic plate, though copper being the commonest gives its name to the entire art. The process is as follows:—The plate is first warmed by putting it on an iron plate, heated by steam, or by a charcoal fire. The ink is pressed into the lines of it, by a wad, made of woollen cloth, rolled up like a ball, with a handle. The superfluity of ink resting on the general surface of the plate is then wiped off, first with a rag, then with the workman's hand, slightly rubbed with whiting. The paper being previously damped, a piece is placed on the plate, and being drawn through the press comes out on the other side printed.

COPPER-PLATE PRESS. The press used by the copper-plate printer. (See *Rolling Press*.)

COPYING PRESS. A machine for speedily producing a fac-simile copy of any manuscript already written. The method is to place on the letter a sheet of thin damp paper, and subject them both to the action of the press, by which means a portion of the ink is transferred from the manuscript to the damp paper. The ink used is the same as common ink, but with sugar added to it. The presses are of various shapes; but the following, which is the invention of the celebrated James Watt, is that most generally used.

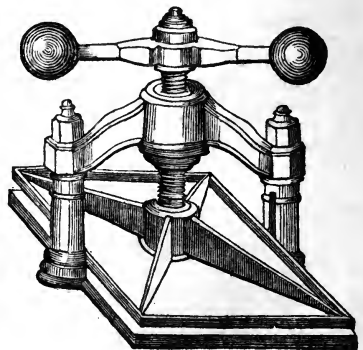

CORAL. A calcareous substance, formed by various species of sea polypus, which construct in concert immense ramified habitations, consisting of an assemblage of small cells, each the abode of an animal. The finest is found in the Mediterranean; it is of a fine red color, and used for making necklaces, crosses, and other female ornaments. It is worked up like precious stones.

CORAL, Artificial, for grottos, &c. may be made by painting the peeled twigs of the hawthorn, or other tree, with melted sealing wax, or dipping them in common wax, or common rosin, colored with vermilion. The painted twigs afterwards to be held near the fire, until a smooth and glossy surface is obtained.

CORBEL. CORBETT. A short projecting piece of wood or stone, intended to carry the groins, or trusses of a roof, or other weight above it. It is often elaborately and grotesquely ornamented.

CORBELLING. A term to signify the projection of one stone, or one brick over another in a wall, in the manner of a corbel.

CORBEL STEP, or CORBIE STEP. When the gable of a house is broken into apparent steps, or ledges.

CORBEL TABLE. A row of corbels supporting an overhanging cornice, parapet, &c.; very common in the Norman buildings.



CORDON. The edge of a stone on the outside of a building.

CORE. The internal mould which forms a hollow in foundry, as the hollow of a tube or pipe.

CORINTHIAN. The fourth order of architecture; the richest and most delicate. Its

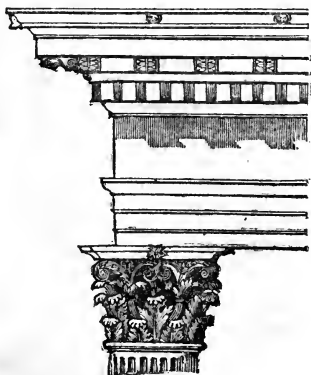

capital is adorned with rows of leaves, and with eight volutes, which support the abacus. The height of the column is $9\frac{1}{2}$ diameters, and its cornice is supported by sculptured modillions. The Corinthian order is a general favorite, both by the ancients and the moderns, Without being overloaded with ornament, like the composite, it is graceful and rich, light and impressive. The splendid ruins at Balbec and Palmyra are noble antique specimens of this style, while there are numerous buildings in London, such as Goldsmith's Hall, which show its true character and beauty.

CORINTHIAN BRASS. It is pretended, that at the burning of Corinth, by Mummius, in the year 146 before Christ, the brazen, gold, and silver vessels of the city were melted accidentally together, and as the ancients knew not how to separate them, they used this valuable alloy wherewith to cast statues, bronzes, vases, &c.

CORK. The bark of the quercus liber, a species of oak which grows abundantly in the southern provinces of France, Italy, and Spain. The bark being stripped from the tree in the spring of the year; it is soaked in water, then pressed flat by the weight of large stones, next dried, and afterwards somewhat charred on the surface by fire. The chief uses of cork are for stoppers of bottles, floats for fishermen's nets, as a buoyant material in life boats, preservers, &c., for the inner soles of shoes, and to line the drawers in which collections of insects are preserved.

CORNICE. The uppermost moulding in any part of a building; thus we say the cornice of a room, of a pediment, of a frieze, pedestal, &c.

CORNISH REDUCING FLUX. Ten ounces of tartar, 3 ounces and 6 drachms of nitre, and 3 ounces and 1 drachm of borax; mixed well together.

CORNISH REFINING FLUX. Deflagrate, and afterwards pulverize, 2 parts of nitre, and 1 part of tartar.

COROLLARY. In mathematics, a consequent truth, which follows immediately from some preceding truth, or demonstration.

CORONA. The lower member or drip of a classical cornice. The flat under-part of it is called the soffit.

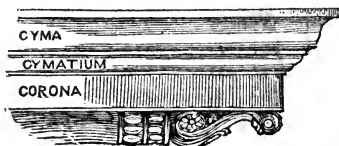

CORPUSCLE. An atom, or one of the minute ultimate particles of which bodies consist.

CORPUSCULAR PHILOSOPHY. That scheme or system of physics, in which the pheno-

mena of bodies are accounted for, from the motion, rest, position, &c., of the atoms that compose them.

CORRIDOR. An open passage, or gallery.

CORROSIVE SUBLIMATE. Bi-chloride of mercury, formerly called the oxy-muriate of mercury. It is a most deadly poison, and as such is used in a weak solution to wash over the plants in herbaria, that they may not be subject to the attacks of insects. It is also destructive to vegetable life, therefore a small portion added to blacking, to ink, &c., preserves them from mould and other funguses; hence its solution is used to soak timber in, to preserve it from the *dry rot*. It is a most powerful antiseptic, and animal bodies immersed in it have remained a great length of time so fresh and uninjured, that no signs of putrescence were discovered in them.

CORSA. (See *Fascia*.)

CORUNDUM. A genus of hard, aluminous minerals, to which the sapphire, ruby, and adamantine spar belong.

CORYDALIA. An alkaloid, found in corydalis and fumaria

Cos, Rule of. The term applied by the Italians to the science of algebra, on its first introduction into Europe.

CO-SECANT, CO-TANGENT, CO-VERSED SINE, are the secant, tangent, and versed sine of the complement of their arc or angle. The prefix *co* being merely a contraction of the word complement.

COSMICAL. An old astronomical word, used to express the rising or setting of the sun, or a star; but more commonly to denote a star's rising or setting with the sun.

COSMOLABE. An ancient instrument for measuring distances, both celestial and terrestrial.

COSMORAMA. The name of an optical exhibition, in which different places are represented as if of their proper size. It is nothing more than an oil painting, seen through a magnifying glass; a square black-

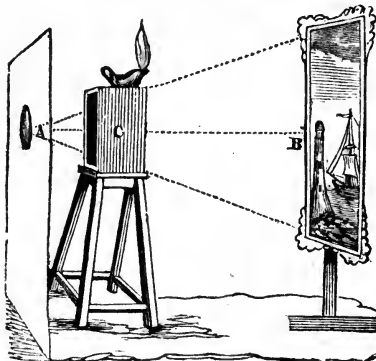

ened frame being interposed between the glass and the picture, so that the edges of it shall be hid from the observer. The light may be thrown upon the picture, either from a window above and before it, or by a lamp placed upon the square frame; the effect of sunset, moonlight, &c., being produced by one or more colored screens placed between the picture and the light.

COVE. Any hollow or concave moulding; a recess; the concavity of an arch or ceiling.

COVED CEILING. When the sides of a ceiling are curved downwards towards the walls, forming part of an arch.

COVERED WAY. A narrow passage between different parts of a castle or fort, for the protection of the garrison.

COVING. The projection of the upper parts of a building beyond its ground plan, as is seen in very numerous old houses, where one story projects beyond that which is under it.

COUCH. The laying of any adhesive substance on wood, plaster, canvas, &c., to overcome, or destroy its porosity; thus, in painting, the canvas is first prepared with a couch of size; oil-cloth, with a couch of whiting, and so on. In many cases this is injurious, in others highly beneficial, as enabling the substance couched to bear better the injuries of the weather.

COULOMB'S TORTION ELECTROMETER is represented in the margin. A is a glass ves-

sel, fitted into a stand at the foot, and having a circular portion of its circumference graduated. Upon A is fixed a long glass tube B; at the top of which is a circular scale of ivory C, with a small hand moveable around the centre. Upon the centre of motion of this hand is suspended a single untwisted fibre of silk, which passes down the tube B, and into the vessel A, where it is terminated by a small piece of straw D, across which passes a wire and light ball E, forming a balance. Also through the top of A passes the wire F, which has a ball at each end. When the upper ball F is electrified, it acts upon the ball E, repelling this to a certain distance, which distance, and consequently the degree of electrization, is indicated by the graduated scale.

COULTER. A stout iron knife, which is fixed in the front of a plough, and which cuts along the edge of the furrow, before it is turned up by the plough-share.

COUNTER DRAWING. Tracing a picture by laying a transparent medium upon it and

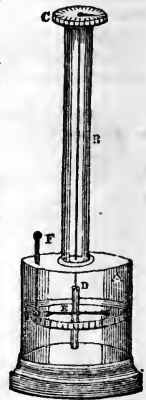

marking down the lines beneath, according as they are seen through the medium.

COUNTER-FORT. A pier, buttress, or oblique wall, built up against a wall to strengthen and support it. It is used in fortification, to resist the pressure of a rampart, &c.

COUNTER-GUARD. An outwork, formed in order to retard the formation of a breach in a fortress.

COUNTER-HARMONICAL. (See *Contra-Harmonical*.)

COUNTER-LIGHT. A window opposite to any thing which makes it appear to a disadvantage. A single counter-light is sufficient to take away all the beauty of a fine painting.

COUNTERPOISE. Any weight which placed in opposition to another weight produces an equilibrium. The weight used with the steel-yard is usually called the counterpoise.

COUNTER-PROOF. In engraving, an impression taken from a newly-printed proof of a copper-plate, printed for the purpose of a closer investigation of the state of the plate; as the proof is in every respect the reverse of the plate, while the counter-proof has every thing the same way.

COUNTER-SINK. To bore such a hole in a plate of brass, iron, &c., that the head of a screw may be buried in it.

COUNTERVALLATION. A chain of redoubts raised about a fortress, to prevent sorties of the garrison. The works being either unconnected, or united by a line of parapets.

COUNTER WEIGHING MACHINE. By the following cut will be recognized a very com-

mon and useful instrument, differing from the common balance in having the scales above, instead of below the beam. The beam is composed of two parallel bars, with three cross pieces terminating in suspension pivots; one in the middle, and one at each end. A table B is placed at one end to receive the weights, and a dish C at the other, to hold whatever matter is to be weighed. The dish rests loosely on a sprandel, or bracket, so that the scale may easily be taken off. Two hollow standards D E, a connecting piece F, and the channelled bottom G, consists of one

stout casing of iron. The vertical motion of the table B, and the scale C, is obtained by the contrivance of two rods descending through D and E, which are connected at their lower ends to a second beam, suspended like the first, and concealed in the base of the stand.

COUSINET. A cushion. A stone on the impost of a pier, destined to receive the first course of an arch; also that part of the Ionic capital between the abacus and the echinus.

COURT PLASTER is made as follows:—Black silk is strained, and washed over several times with the following mixture. Dissolve half an ounce of balsam of benzoïn in 6 ounces of spirits of wine; and in a separate vessel dissolve 1 ounce of isinglass, in as little water as possible. Strain each solution, mix them, and let the mixture rest, so that any undissolved parts may subside; when the clear liquid is cold, it will form a jelly, which must be warmed before it is applied to the silk. When the silk coated with it is quite dry, it is to be finished off with a solution of 4 ounces of Chian turpentine in 6 ounces of tincture of benzoïn.

COWARD'S AIR ELECTROMETER, consists of a glass cylinder, 3 inches diameter by

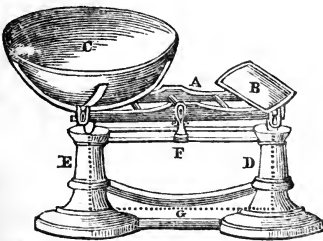

8 inches in length; on each end of which a brass cap is cemented air-tight. Passing through the upper cap, and near to the edge is a glass tube B, blown with a funnel-shaped end, for the purpose of exposing a greater surface, and bent so as to leave a short parallel arm of $2\frac{1}{2}$ inches. To the long arm of this tube a narrow graduated scale of ivory is attached. C and D are brass wires and balls passing through the caps; the upper one sliding in a collar of leather. To use the instrument, fill the tube B to the height of about 2 inches, with any fluid; on the surface of which, in the long arm, is to rest a light gauge made of quill, part being cut so

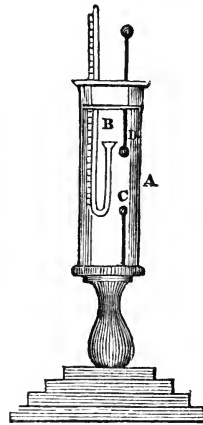

8 inches in length; on each end of which a brass cap is cemented air-tight. Passing through the upper cap, and near to the edge is a glass tube B, blown with a funnel-shaped end, for the purpose of exposing a greater surface, and bent so as to leave a short parallel arm of $2\frac{1}{2}$ inches. To the long arm of this tube a narrow graduated scale of ivory is attached. C and D are brass wires and balls passing through the caps; the upper one sliding in a collar of leather. To use the instrument, fill the tube B to the height of about 2 inches, with any fluid; on the surface of which, in the long arm, is to rest a light gauge made of quill, part being cut so

as to act as a spring, which will hold it at any part of the tube. When a shock is passed from D to C, the air within A is agitated, and pressing upon the fluid drives the gauge upwards, where it is retained at the highest point by its spring.

COWL. The moveable top of a chimney; also a wire cap, covering the top of a locomotive engine, and intended to prevent the escape of lighted flakes, of fuel, &c. It is made of various shapes.

CRAB. A small portable crane, used for raising materials, &c.

CRACKERS. Fire-works, which when fired go off with several small explosions. They are made in a long case, formed of three or four thicknesses of paper, rolled round a long wire, and pasted at the outer edge; then loosely filled with gunpowder, folded up in short alternate doublings, and tied very tightly in the middle, around each doubling. When fired, the various doublings inflame in repeated succession.

COUPLED COLUMNS. Columns arranged in pairs.

COUPLES, or MAIN COUPLES. The same as trusses for roofs, which support the roof in different lays.

COUPLINGS. In many cases, particularly where many machines are moved by the same power, it is important to possess the means of stopping any one of them at pleasure, and of restoring its motion without interfering with the rest. To produce this effect, a great variety of combinations have been invented, under the name of *couplings*. The *clutch* is an example; the *fast* and *loose pulley* another. (See *Pulley*.)

COUPLING BOX. An angular box, or frame of iron, or wood, which fitting upon a spindle enables the motion of the frame to be continued to the spindle, while the removal of the coupling box again restores it to a state of rest.

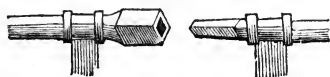

COURANTINE. (See *Rocket*.)

COURONNE DE TASSES. A galvanic battery so called. It consists of a number of

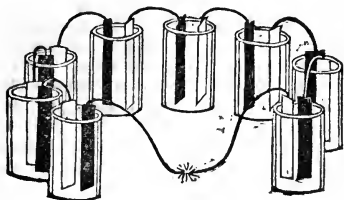

glasses, jelly pots, or similar vessels, in each of which are placed two pieces of metals, of dissimilar electric properties; for example, zinc and copper—the zinc of one vessel being connected with the copper of the other. The outer cups, or vessels, having a wire only to its extreme plate of metal; the wire therefore of one extremity being joined to the wire of the other extremity completes the electric circuit, and causes the fluid to circulate around the whole series.

COURSE. A continued level range of stones or bricks in a wall, as far as the solid part runs. In slating or tiling it is a range of slates or tiles.

COURSE. In navigation, the point of the compass, or horizon, which the ship steers on. It is sometimes reckoned in degrees; sometimes in points of the compass.

COURSE OF PLINTHS. The same as string course.

COURSING JOINT. The joint between two courses of brick, or stone work.

CRADLE. In engineering, is a large wooden frame, into which a boat or barge may be floated, in order to be conveyed by pulleys, &c., from one level of a canal to another, without the aid of the usual locks.

CRADLE VAULT. The same as cylindrical vault.

CRADLING. A mass of timber work in arched and groined ceilings, in order to support the lath and plaster; also the rough timbering which supports the entablature of a shop front. By coopers it signifies the cutting a cask in half lengthways, in order to make it pass a narrow passage, and restoring it afterwards to its original form and degree of tightness.

CRAMP. A metal tie, for securing the several stones of a wall together. A vertical cramp is called a *dowel*, or *plug*. Iron is the usual material employed, though copper is far superior. Also synonymous with clamp, (which see.)

CRAMPOONS. Pieces of iron, hooked at the ends for the drawing or pulling up timber, stones, &c.

CRANE. A machine used in raising or lowering heavy weights. Cranes are generally constructed upon the principle of the wheel and axle, or else upon that of Bramah's press; of these the former is much the more common.

The collar B is made to revolve in an iron or stone block, fixed in the ground. The post C is firmly attached to the collar, and carries the jib D E; it has a double stay, one on each side of the post C, the pulley E working between them. The workman turns the handle F, which moves the toothed wheel G; this turns a second wheel H, on the axis of which the rope is coiled up, lifting the weight at the same time. L is a

fly wheel with a brake upon it, in order that the workman may have complete control over the crane when lowering any goods.

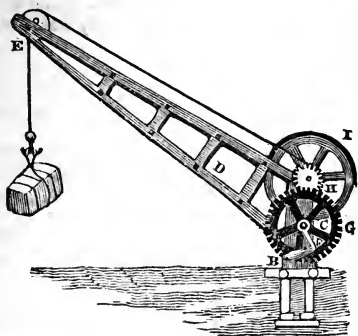

CRANE, Chinese. A modification of the wheel and axle, which for simplicity of structure and immensity of power is worthy of more attention than it has received. As a portable crane, for the lowering of wine casks into cellars and similar purposes, it is invaluable

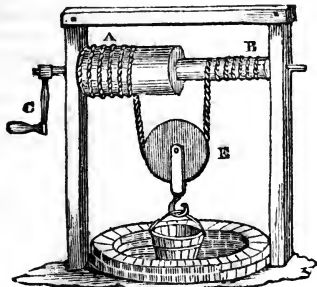

A B is a windlass, worked by the handle C; this windlass has two diameters. The cord is wound round the part A, then passed under the moveable pulley E, then carried to the narrower part of the windlass B. In proportion to the square of the diameters of the two parts of the windlass, so will be the power of the instrument.

CRANK. A contrivance for changing circular into alternate motion, or *vice versa*. Cranks are either single or multiplied; if single, there is but one connecting rod attached to the crank, and consequently but one reciprocating motion is produced at each revolution of the crank; if the crank be double, two motions are produced—one in each connecting rod; if still more compound, the like multiplication of motion will take place: for example, the following crank

would work three piston rods at the same time:—

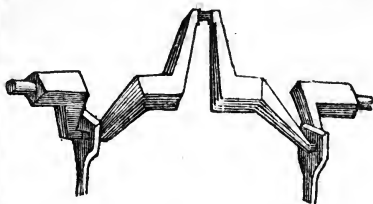

The motion produced by cranks is easy and gradual, being most rapid in the middle of the stroke, and gradually retarded towards the extremes, so that shocks and jolts in the moving machinery are diminished, or wholly prevented by their use.

CRAPE. A transparent textile fabric, somewhat like gauze, made of raw silk, gummed and twisted at the mill.

CRATER. The mouth of a volcano.

CRAYONS. Slender, soft, chalk-like pencils, used by the artist for sketching upon paper. The hard black crayons, called French crayons, are made of charcoal, cut into slips, and afterwards soaked in hot wax. Other crayons are made of various colored powders, united together by different cements, of which the following is recommended:—6 parts of shell-lac, 4 parts of spirits of wine, 2 parts of turpentine; to which quantity of ingredients are to be added, 12 parts of the coloring matter, and 12 parts of blue clay. (See also *Creta Lævis*.)

CRAYONS, Lithographic. Mix together by a gentle heat, white wax 4 parts, hard tallow soap, and shell-lac, each 2 parts, lamp black, 1 part. It may be cast into moulds for use.

CRAZING. A term employed by potters to indicate the cracking of the glaze upon porcelain and delft articles.

CREAM OF TARTAR. Supertartrate of potass; or now called cream tartrate of potass, from the supposition that it owes its characters to a peculiar acid, called the cream tartaric acid.

CREEPERS. Synonymous with crockets, (which see.)

CRENELLATED. An embattled moulding; used in Norman buildings.

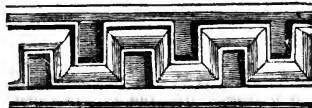

CRENELLES. Loop-holes or open work in parapets, &c., for archers to shoot through. (See *Embrasure*.)

CREOSOTE. A liquid obtained by the distillation of wood tar. It is a corrosive, limpid, colorless, strongly-scented liquid; is a non-conductor of electricity; refracts light powerfully, and burns in a lamp with a ruddy, smoky flame. Creosote combines with alcohol, hydric ether, naphtha, potass, soda, ammonia, lime, baryta, and certain oxydes. It prevents the putrefaction of animal substances, and is therefore used in curing provisions, though a few drops communicates a strong smoky flavor to many pounds of meat. Its action on the nervous system is so great that it is applied with considerable success to cure the tooth-ache, and to recent burns and scalds.

CREPUSCULUM. Twilight.

CRESCENT. A representation of the moon in her state of increase. Having been once stamped on the coins of Byzantium, indicating that that city was the moon of the Roman empire, as Rome itself was the sun; the Turks have adopted the crescent as their national emblem, although the appropriateness of its first adaptation is no longer considered.

CREST. The ornamented work which finishes the upper part of a cornice, canopy, parapet, &c. The Vitruvian ornament was common among the Romans; the Tudor among the buildings of decorated and perpendicular Gothic styles. Also the highest part of a shrine. Among carvers a crest is a piece of work to adorn the upper part of any thing, as the top of a looking glass frame, &c.

CREST TILES. Ornamental tiles, formerly used to cover the ridge and hips of a roof.

CRETA LEVIS PENCILS. A soft kind of drawing crayons, made of pipe clay, mixed with various earthy and metallic pigments, and occasionally hardened by a small quantity of glue. The mixture is either to be put when soft into pencil sticks, or moulded into shape. These crayons have much brilliancy, and from their soft texture, the tints blend easily into each other.

CREUX. A French word, to which there is no corresponding English term. It implies a hollow in any thing, or a scooping out.

CRIGHTON'S METALLIC THERMOMETER, derives its action from the different expansibility of metals by heat. A compound bar is formed by uniting together a bar of zinc, A B, eight inches long, one inch broad, and a quarter of an inch thick, to a plate of iron, E F, of the same size. The lower extremity of the compound bar is firmly fixed to a mahogany board at B F. A pin above A E, plays in a forked opening of the short end of the lever or hand C. When the temperature is raised, the superior expansion of the zinc will bend the whole bar, as in the figure, and the index C will move along the gradu-

ated arc, from right to left, in proportion to the temperature. In order to convert it into a register thermometer, Crighton contrived two slender hands, D D, on the axis of the index; these lie below the index, and are pushed in opposite directions by a stud on the central part of C.

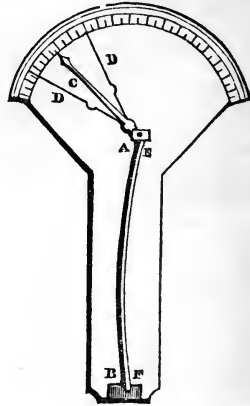

CROCKETS, CROQUETS. Leaves, or bunches of foliage on the angles of a Gothic building, particularly on spires, pinnacles, canopies, and drip-stones. The varieties are numerous.

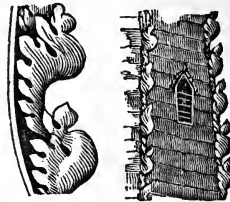

CROCONIC ACID. A substance of peculiar properties, procured by distilling potassium from a mixture of carbonate of potass and charcoal.

CROCUS HEAD. A flower used in scroll ornaments, to break the length of a continued tendril, and to relieve the stiffness and meagreness of its appearance. Like the flower itself, it has three leaves, and is without a calyx or cup. It is usual also to make it contracted, like a nearly-closed crocus.



CRONICAL. (See *Achronical*.)

CRONOS. A name anciently given to the planet Saturn.

CROSS. The symbol of the Christian religion; therefore a common decoration of Christian buildings, particularly as a terminal ornament. Churches and cathedrals are most generally of this form, for example, St. Paul's. If the four arms be equal in length, it is called a Grecian cross; if one be longer than the others, it is Roman. The monumental buildings erected in different parts of the kingdom by Edward I., in honor of his queen, are called crosses; so also are numerous market houses, &c., a cross being a constant ornament upon them. The following are some terminal crosses from English cathedrals:—

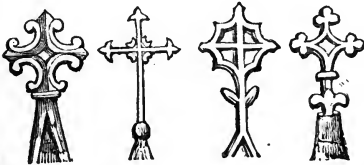

Cross, Surveyor's. An instrument used in surveying, for the purpose of raising perpendiculars; it consists of a simple flat piece of wood, with two saw cuts at right angles to each other; or else of a flat piece of wood, with four sights upon it, the lines joining which are also at right angles to each other: thus—

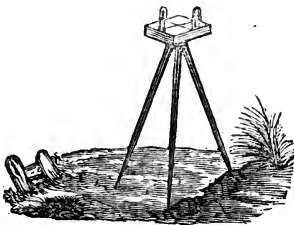

It is used as follows:—Let two of the sights agree with the base line of the survey, and carry the cross along this line, until some object, which it is wished to draw the perpendicular from, be seen through the other two sights; then marking on the base line the position of the cross, the perpendicular can be noted as arising from that spot.

CROSS BANDED. In cabinet work, is when a narrow ribbon of veneer is inserted into the surface of any piece of furniture, wainscoting, &c., so that the grain of it is contrary to that of the general surface.

CROSS GARNETS. Hinges which have a cross piece on one side of the joint, and a long strap on the other.

CROSS-HATCHING. A term used by engravers, to signify such shades or tints as are produced by crossing the lines. The following is an example of cross-hatching in wood: it is the most difficult part of the art to learn, because as the black parts require to be left, and the rest to be cut away, there is great danger in cutting the lines through each other, and in taking away cleanly the diagonal interstices between them.



CROSS MULTIPLICATION. (See *Duodecimals*.)

CROSS STAFF, or FORE STAFF. An instrument used formerly by mariners for taking the meridian altitude of the sun or stars.

CROSS SPRINGERS. The transverse ribs of a groined roof.

CROSS QUARTERS. (See *Quatrefoil*.)

CROSSETTE. A truss or console on the flank or return of an architrave of a door, window, or other aperture.

CROSS VAULTING, is formed by the intersection of two or more simple vaults of arch-work.

CROSSING ON RAILWAYS. The necessary arrangement of rails to form a communication from one line to the other.

CROSSING POINT, FIXED POINT, or POINT PLATE. The points where one rail of a railway crosses another.

CROTONIC ACID. The active principle of the seeds, or of the oil of croton tiglium.

CROW-BAR. A strong bar of iron, used as a temporary lever.

CROWN, or CROWNING. The upper member of an arch, a wall, a battlement, &c., is called a crown; also the corona and superior mouldings in an architrave.

CROWN OF AN ARCH. The top, or highest part.

CROWN GLASS. Best window glass; its composition is 200 parts of soda, 300 parts of fine sand, 33 parts of lime, and 250 ground fragments of glass.

CROWN SAW. A species of circular saw, formed by cutting the teeth round the edge of a cylinder. The surgical instrument, called the trepan, is an example.

CROWN WHEEL, or CONTRATE WHEEL. A wheel, the teeth of which are at right angles to the plane of the wheel, or parallel

to the axis of it. It is employed occasionally where an alteration of motion from a perpendicular to a vertical position is required. Crown wheels have more friction than bevel wheels, thus they are seldom used, except in small pieces of machinery. There is one in a watch, as may be easily seen.

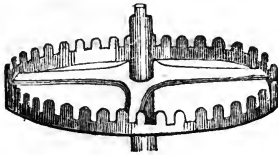

CRUCIBLE. A small conical vessel, made of some material which, when burnt, is very refractory in the fire, impervious to moisture, and not readily acted upon by corrosive liquids. Crucibles are used by the founder and the chemist for holding ores, metallic substances, earths, &c., which are to be subjected to a strong heat. The following is a receipt for forming a proper clay wherewith they may be made:—Half a pound of Stourbridge clay dried, quarter of a pound of old crucibles ground fine, one-eighth of coke powdered, and one-eighth of pipe-clay. The black lead crucibles are made of two parts black lead and one of fire-clay, mixed with water, and moulded into form.

CRUDE. Raw, unfinished, or unrefined. In painting, crudeness is when the colors are laid on roughly, and are not blended properly and softly together.

CRUICKSHANK'S GALVANIC BATTERY, or TROUGH, is formed of a series of double metallic plates, formed of two dissimilar metals, as copper and zinc, soldered together at top, and cemented into a trough or long box, with any resinous cement; each pair of plates is separated by a narrow space from the rest. When a trough of this description is filled with a mixture of acid and water, a galvanic action ensues; and if a wire be connected with the cell at each end, and the wires made to touch each other, the circuit will be complete, and the effects become apparent.

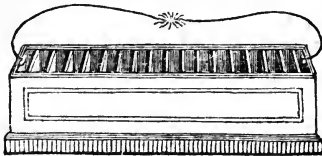

CRUSHING. The breaking of materials into small parts, such as is practised in mines and in various manufactures—either by stamping, pounding, pressing, &c.; by weights, presses, rollers, or hammers.

CRYOPHORUS. A simple instrument, invented by Dr. Wollaston, for the purpose of

illustrating the effect of evaporation in producing cold. It consists of a glass tube, from 18 inches to 2 feet in length, having an internal diameter of one-eighth of an inch. The tube is bent at right angles near the ends, both of which are terminated by bulbs.

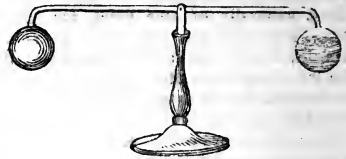

One of the bulbs is nearly filled with water, which being made to boil, the air is expelled from the tube and bulbs, which remain filled with steam. The open bulb is then closed, by melting the glass at its capillary termination. When the empty bulb is immersed in a mixture of salt and snow, the vapor existing within it is condensed, which removing pressure from the surface of the water in the other bulb, enables it to evaporate rapidly, and the vapor being condensed as speedily as it is formed, the water is readily frozen.

CRYSTAL. Any solid body which has assumed a regular and determinate angular form. Crystals are either natural or artificial; the natural crystal is one that is formed without the intervention of human art, and which cannot be thus formed. The artificial crystal is such as may be manufactured, though the particular forms that even these last assume are no less subject to natural laws. Natural crystals are seen in numerous

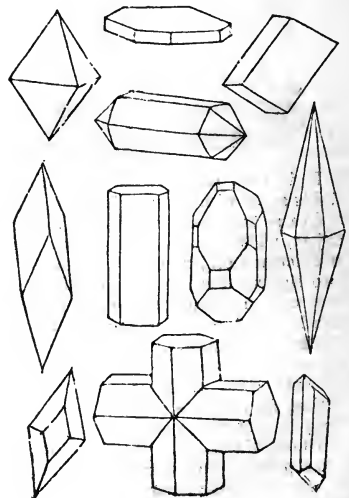

gems, quartz, metals, and minerals. Artificial crystals are exemplified by chemical salts, sugar, &c. The forms that crystals assume are almost endless, though each, with a few exceptions, remains constant to one appearance. The preceding cut shows various forms of crystals.

CRYSTALLINE HEAVENS. In old astronomy, two orbs imagined between the primum mobile, or first power, and the firmament, in the Ptolemaic system, in which the heavens are supposed solid, and only susceptible of a single motion.

CRYSTALLIZATION. The process of nature, by which the particles of bodies are arranged systematically in passing from a liquid to a solid state, or changing into what are called crystals. Melted sulphur, for example, when cooling, is seen to shoot into needle-shaped crystals, and a mass of it being afterwards broken, is found to consist of a mass of such crystalline bodies.

CRYSTALLOGRAPHY. The science that treats of the formation, shape, and peculiarities of crystalline bodies.

CRYPT. A vault under a sacred building.

CTESIBIUS'S PUMP. A pump much used among the ancients, and still a valuable instrument. It combines the principle both of the common suction pump and the force pump, as follows:—

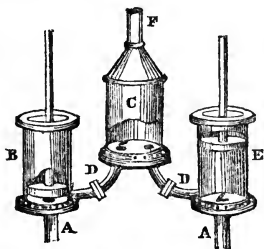

Suppose A A are two pipes, leading from a well below, to the vessels B and E. Each of these vessels is furnished with a valve at bottom, a pipe D D, leading to the vessel C, and a solid piston, capable of an alternate motion up and down by a connecting rod at top; moving so that when one piston is up the opposite one is down. When the piston of E rises, the water from the well passes through the valve at bottom into E, and when it sinks by the return stroke, the valve at bottom is closed, and the water which is now in E is forced along the pipe D into C; while the same action, but in alternate times, is taking place in B, both tending to force water into C, and propelling it up the pipe F.

CUBATURE, is the finding the solid or cubic contents of any proposed body; the same as quadrature signifies the finding the superficial area.

CUBE. A regular solid body, consisting of six equal sides or faces—it is also called an hexaedron.

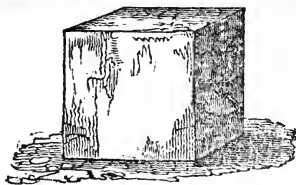

CUBE NUMBER, is a number produced by multiplying a number into itself twice: thus 27 is a cube number, because 3 multiplied by 3, and the product afterwards by 3, makes 27.

CUBE ROOT. The cube root of any number is such a number as being multiplied twice by itself will produce that number: thus 2 is the cube root of 8, because $2 + 2 + 2 = 8$.

CUBIC EQUATION. That equation in algebra in which the unknown quantity rises to the third or cubic degree of power; as, for example, $ax^3 + ax^2 + bx = 10$ is a cubic equation.

CUBIC NITRE. Nitrate of soda.

CUBO-CUBE. The sixth power, as 64 is the sixth power, or the cubo-cube of 2.

CUBO-CUBO-CUBE. The ninth power; as 512 is the ninth power of 2.

CUDBEAR. The dyeing material, or coloring matter of the orchil, or archil lichen, called also litmus and lacmus; and sometimes, though improperly, turnsole. It is used in dyeing to communicate a bloom to other colors.

CUDDY. A three-legged stand, forming a fulcrum upon which a long pole is placed, which is used as a lever to lift and lay railroad blocks.



CULLET. In the manufacture of all common glass, a portion of broken glass is always mixed up with the raw materials; this is technically known under the name of cullet.

CULM COAL. The same as anthracite

CULMINATE. To be vertical, or on the meridian.

CULMINATING POINT. That point of a circle of a sphere that is on the meridian.

CULMINATION. In astronomy, the passage of any heavenly body over the meridian, or its highest altitude during its diurnal revolution.

CULPEPPER'S MICROSCOPE, or the PYRAMIDAL MICROSCOPE. This instrument, though of an old construction, and inconve-

nient form, is yet one which possesses considerable power, and was at one time almost the only one sought after. It is shown in the cut as set out for use; it stands 12 or 14 inches high, and has four or six different powers.

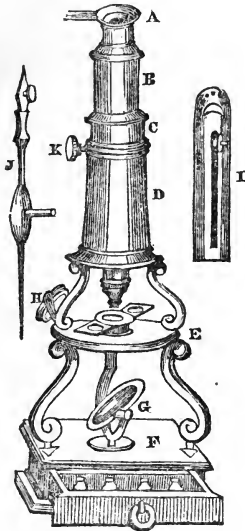

A is the slide-head, turned concave. B the eye tube, containing two powerful lenses. C the slide tube, by which the instrument is adjusted. D the body, in which the upper part slides, having in some cases a rack and pinion movement at K. E is a circular brass table, supported upon three legs, which are screwed upon the stand F. In the middle of E is a spring object holder. G the mirror, which reflects the light through the object to the eye. H an illuminator or lens, for reflecting light upon opaque objects. I is a contrivance, called the frog plate; and J is the nippers and needle.

CULVERT. An arched drain, for conveying rills and brooks of water under canals or roads, from the higher level on the one side to the lower level on the other; they are also employed for discharging the rain water out of hollows.

CUMMING'S (Dr.) STATICAL THERMOMETER. An instrument intended as a mode of opening windows and ventilators in apartments, by the variations in temperature of the included air.

A is a tube and ball, either of glass or iron, the ball being capable of holding 4 or 5 pints of air, and the tube B, about 25 inches long. A portion of the tube is filled with mercury, and in this state is inverted, and the end plunged in a jar of the same fluid;

to the top of the ball is attached a string, which after passing over the pulleys D and E, is finally fastened to the window F. When the heat of the apartment rarefies the air in the ball, the mercury is driven out, and the

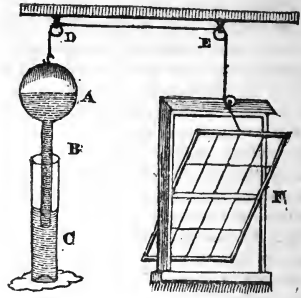

ball and tube being thereby lightened, rise and suffer the window to swing itself open. An increase of cold will produce the contrary effect.

CUMMING'S (Dr.) REGISTER THERMOMETER, BAROMETER, &c., may be understood by the following explanation and cut:—

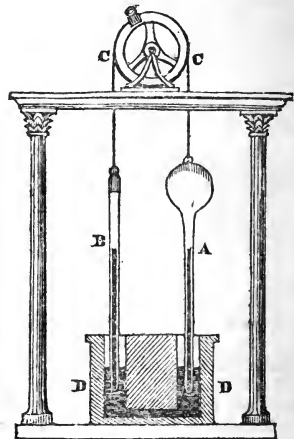

A is a ball and tube, formed, filled, and inverted, as in the last instrument. The cord of it after passing over the pulley, carries a barometer tube, B, which, equally with A, dips into the syphon filled with mercury, D D, in both sides of which the mercury will always remain at the same level. On the wheel or pulley C C, is an index, to which a pencil may be attached, for tracing the variations of the instrument, on a plate, revolving by means of clock-work.

CUMMING'S (Dr.) HYGROMETER, is merely a tube of bright metal, containing an

air thermometer and scale, the bulk of the former being surrounded with fine sponge. This is attached to a portable exhausting or condensing syringe, by which a current of air is produced through the tube. The sponge is damped with ether, or other very evaporable fluid, and the current of air in passing through it, produces evaporation in proportion to the strength of the current, which evaporation is rendered conspicuous on the surface of the metallic tube, as well as the degree of cold induced by the thermometer.



CUMULO-STRATUS, Twain Cloud. Masses of rounded clouds mixed with those that are fleecy, the former being the lowest in position—mostly accompanied by a westerly wind.

CUMULO-CIRRO-STRATUS, or NIMBUS, The Rain Cloud. A horizontal sheet of clouds, over which the cirrus clouds spread, and the cumulus enters it from beneath.

CUMULUS. Clouds which are in conical or rounded convex heaps; as is frequently observable in the west at sun-set, when the rest of the sky is clear, and otherwise, both in fine weather, and at the clearing-up of wet.

CUP and BELL. A scroll-work ornament of considerable beauty and variety, used occasionally to terminate a tendril, but more frequently as a springer for smaller tendrils, as in the following example :—

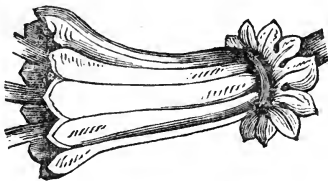

CUP VALVE. A valve exactly resembling a conical valve, except that it is made in a semi-circular or cup-shaped form. It is superior when used as a safety valve, because it is not so apt to stick in its socket as the conical safety valve is. This is particularly the case with locomotive engines, in which the vibration of the boiler, by disturbing the pendant ball, has the effect of liberating the valve, should it be inclined to adhere to the valve box, or cavity, in which it is placed.



CUPEL. A shallow earthen vessel, used in that part of the process of assaying, called cupellation. It is made of the residue of

burnt bones, wetted, and rammed into a mould, which gives it its shape. The furnaces used in smelting iron are also called cupels.

CUPELLATION. A process in assaying the precious metals. It is performed as follows:—The metal is put into a cupel, together with a certain proportion of lead, and then exposed to a considerable heat in a muffle, or small earthen oven, fixed in the midst of a furnace; the lead vitrifies, and collects to itself all the alloys and impurities combined with the precious metal. The lead thus rendered into a glass, combines with the cupel itself, and leaves the precious metal pure and uncontaminated.

CUPOLA. A small dome, terminating one which is larger, or else rising from the roof itself, erected either for ornament, for a bell turret, a ventilator, or to light a staircase, &c., often synonymous with lantern.

CURB. In a general sense, a check, or restraint. A curb-stone is the outer edge of a foot pavement, and between it and a road. The curb to brick steps is a piece or pieces of timber running from end to end to prevent the wearing of the bricks. The wooden frame around the brick-work on the top of a pit or well, is also a curb.

CURB ROOF. A roof formed of two sets of rafters on each side, arranged in the following form :—



CURDLED LENSES. A name given to those optical glasses which have been so imperfectly ground as to show minute ridges or cavities to the naked eye. This defect arises from three causes. First, an irregular or ill-formed tool. Secondly, the lens being polished with an improper motion. Thirdly, the covering of the tool with the requisite grinding and polishing powders, which are emery and washed putty powder, being improperly laid on.

CURRYING. The art of preparing leather after it has been tanned, with oil, tallow, and other matters calculated to give it pliability or suppleness, and durability.

CURRENTS, Electrical. The passage of the electric fluid from one pole of an apparatus to the other.

CURSOR. Any part of a mathematical instrument that slides backwards and forwards, for example the moveable leg of a beam compass; the joint of the proportional compasses; the hand of a barometer; the beam of the trammel, &c.

CURTAIN STEP. The lower step of a flight, finishing at the end in the form of a scroll, following the plan of a hand-rail.

CURTAIN. That part of a battlement between any two towers or bastions.

CURTATE. In astronomy, is the distance of a planet's place from the sun or earth, measured to the ecliptic; or the interval between the sun and earth, and that point where a perpendicular, let fall from the planet, meets with the ecliptic.

CURTATION, is the interval between a planet's distance from the sun, and the curtate distance.

CURVATURE OF A LINE, is its bending or flexure, by which it becomes a curve of any particular form or properties.

CURVE. In geometry, is a line, the several parts of which proceed in different directions, and are successively directed towards different points in space. A plane curve is that of which the several points in it lie in the same plane, and when this is not the case, the curve is said to be one of double curvature. The principal curves are the *catenary*, *cisoid*, *cycloid*, *cardioide*, *caustic*, *epicycloid*, &c., (which see.)

CURVES, Magnetic. The particular arrangement of particles of iron when acted upon by a magnet; they emanate from one pole, and are attracted towards the other, as may be seen in the following cut:—



CURVILINEAR. Any thing relating to curves, as curvilinear angle, figure, surface, &c., being such as are formed or bounded by curves.

CURVILINEAD. Any instrument adapted to form a curve, as that described under *Arcograph*, &c. The following is an ingenious contrivance of this kind, having the peculi-

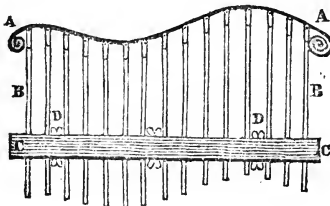

arity that it can form a hollow, an irregular, and a mixed curve, as well as one which is regularly convex.

A A is a light flexible bar of steel or brass. B B, &c., are a series of wires at regular short distances, fastened to the bottom of A A, and moveable up and down in the wooden bar C C. Pulling these down, or pushing them up, will, of course, bend A A into the required shape. It may be retained in this shape by the aid of the keys D D.

CUSHION. In electricity, that part of an electrical machine which presses against the glass cylinder or plate. According to the size of the machine, it may be from one to two inches wide, and should be stuffed with a conducting substance, or if not, the amalgam upon the flap of it, should be connected with the chain that reaches to the ground. In the front of the cushion is fixed a loose piece of leather, bearing a black silk flap upon the top of it.

CUSHION CAPITAL. A capital so sculptured as to appear like a cushion pressed upon, as is very common in Indian buildings, and of which there is a cut under *Abacus* and *Capital*. The name has also been given to the common Norman capital, consisting of a cube rounded off at its lower extremities, as is seen under *Arcade* and *Arch*.

CUSP, or FEATHERING. Small projecting arcs, with which the heads of Gothic windows are ornamented.



CUSP. In astronomy, signifies the horns of the moon, or other heavenly body. In geometry, it is the point where two curves meet each other.

CUTBERTSON. (See *Balance Electrometer*.)

CUTTING. A name applied to excavations.

CUT-WATER. The lower portion of a pier, separating two arches of a bridge crossing a river. It is usually of hard stone, and pointed towards each end, that it may the better resist the action of the stream, and the blows of floating ice.

CYANIC ACID. A union of cyanogen and oxygen.

CYANIDES, or CYANURETS. Combinations of cyanogen, with various bases.

CYANOGEN. The base of prussic acid; called also prussine, and from its composition, the bicarburet of nitrogen, consisting of 2 atoms of carbon to 1 of nitrogen. It may be obtained from the pure crystals of the

cyanuret of mercury, by distilling this salt, and collecting the gas which is evolved over mercury: under a pressure of 3 or 4 atmospheres it condenses into a limpid colorless liquid. The gas is colorless, with a strong smell of bitter almonds; it burns with a peculiar purple flame, and its specific gravity is 1.82. By peculiar management, it unites with oxygen, chlorine, hydrogen, iodine, sulphur, phosphorus, and bromine, and many of the metals, constituting with the last class of substances what have been called equally, cyanides, cyanurets, and nitro-carburets. These unite with each other, and form double cyanurets.

CYANOMETER. An instrument contrived by Mr. Sausseur, to measure the intensity of the color of the sky, and thereby to deduce the quantity of vapour floating in the atmosphere, it being known that the color is weakened in proportion to the abundance of aqueous particles in the air. The cyanometer is a circular band of thick paper or paste-board, divided into 51 parts, each of which is painted of a different shade of blue, decreasing gradually from the deepest to the weakest. The colored zone is held in the hand of the observer, who notices the particular tint which corresponds to the color of the sky. The number of this tint, reckoning from the darkest, is the intensity.

CYCLE. A certain period or circle of numbers, proceeding orderly from first to last; then returning again to the first, and so circulating perpetually. Cycles were invented in order that we may calculate time in spaces convenient for daily use, and yet make due allowance at the same time for the irregularities of the motions of the heavenly bodies, as will be seen from the following examples:—

CYCLE OF THE SUN, OR SOLAR CIRCLE. A revolution of 28 years, in which time the days of the month return again to the same days of the week—the sun's place to the same signs and degrees of the ecliptic on the same month and days—and the leap years begin the same course over again, with respect to the days of the week on which they fall.

CYCLE OF THE MOON, commonly called the *golden number*, is a revolution of 19 years, in which time the conjunctions, oppositions, and other aspects of the moon, are within an hour and a half of being the same as they were on the same days of the month 19 years before.

CYCLOGRAPH. Synonymous with arco-graph, (which see.)

CYCLOID, OR TROCHOID. A mechanical curve of somewhat curious properties: it may be understood and formed as follows:—

Conceive the circle *C* to revolve or roll along the straight line *AB*, until a fixed point in the circumference at *D*, which at first

touched the right line at *A*, touches it again at *B*, after an entire evolution of *C*. Then the curve *AEB*, traced by the point *D* upon the plane, will be the *cycloid*; if instead of the line *AB* being a straight line, it were the part of a circle, the curve described would

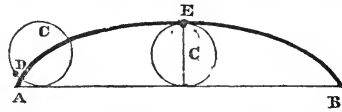

have been an *epicycloid*. The cycloid is the curve of swiftest descent; if we suffer a ball to roll down the concave side of a cycloid, it will reach the bottom in less time than by running in any other curve.

CYANURIC ACID. A peculiar acid in urea

CYCLOPIAN WALLS. (See *Masonry*.)

CYLINDER. A solid having two equal circular ends, parallel to each other; and every plane section parallel to the ends, is also a circle, and equal to them. Cylinders are either right, that is erect, or oblique and sloping.

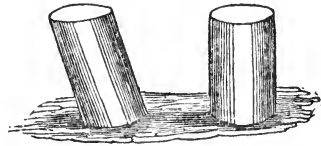

CYLINDER ELECTRICAL MACHINE. An electrical machine, the moving part of which is a cylinder of glass. The arrangement of the various parts is as follows:—

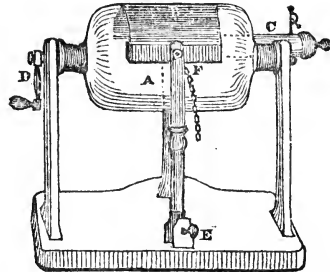

A is the cylinder, fixed into two brass or wooden caps, one at each end. *B* is the silk flap belonging to the cushion, and which passes over the cylinder until it approaches the points of the prime conductor *C*. *D* is a handle, whereby the cylinder is turned. *E* is a screw to regulate the pressure of the cushion upon the cylinder. *F* is a chain reaching to the ground, to collect and supply the fluid to the cushion.

CYLINDER, STEAM. That part of a steam engine in which the piston moves, and in

which the motion of the whole is produced, by the alternate admission and condensation of the steam from the boiler. The length of the cylinder should be about twice its diameter, though occasionally cylinders have varied much from this proportion. Steam cylinders have mostly an erect position: that belonging to Maudsley's steam engine vibrates to and fro. In some engines the cylinder is placed horizontally, or else at a certain angle with the horizon.

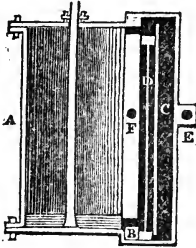

A is a barrel ground smoothly inside, within which is a piston, moveable up and down. C is a square box, called a valve box, divided by a partition, containing the slide valve D, and connected with two pipes, one the pipe to admit steam E, and the other the eduction pipe F, which lets off the steam into the condenser. (See *Slide Valve*.)

CYLINDRIC. Any thing in form of a cylinder.

CYLINDRICAL MIRRORS. All objects seen by reflection in a cylindrical mirror are necessarily distorted, and that either in width or length, according as the mirror is presented to them. Cylindrical mirrors, which are now very uncommon, used to be made for this purpose, and were accompanied with a series of distorted figures, which, when

seen by the eye, have neither shape nor meaning, but when laid down before a cylindrical mirror, the reflected image of them has the most perfect proportions. The effect is shown below, where the lower object is the distorted figure, whose image in the mirror has the appearance of a regular portrait.



CYLINDRICAL VAULTING. A vault, consisting of a plain half cylinder; called also barrel, wagon, tunnel, or cradle roof. The Thames Tunnel and arches of London Bridge are examples.

CYLINDROID. A solid, resembling a cylinder, except that it has elliptical ends, instead of circular ones.

CYMATIUM. A small moulding, terminating several members of a building, as the upper moulding of a Roman Doric abacus. The moulding around the top of a modillion; also between a tympanum and its cornice, or on the upper part of the architrave. The upper mouldings of a pedestal, when it is without a regular cornice, are also so called. (For figure see *Corona*.)

CYTISIN. A peculiar principle supposed to exist in the laburnum.



The fourth letter of our alphabet, of the order of mutes. The ancient Coptic *Dau* was represented by a character like a modern D turned sideways \sqsubset .— Whence the Greeks derived their *delta* Δ , and from this last the Romans their D. In Greek it signifies 4; among the Roman numerals 600, though the Romans themselves did not use it with this signification, it not being considered indicative of 500 till the sixteenth century after Christ. In inscriptions, mottos, titles, &c., D implies doctor, dominus, dat, donat, dedicat, defensor, &c., besides being occasionally

used for B and L, as *des* for *les*. On French coins it indicates *Lyons*. In music D designates a particular note, supposed to be represented by the monosyllable *re*.

D VALVE. A sliding valve, common in steam engine work, the use and structure of which are as follows:—D in the cut represents a square box, supposed to be full of steam, which is supplied by the pipe B. Passing through this, and capable of moving up and down is the rod G; to which is fastened the valve itself A, which is merely a solid piece of metal of the shape represented. C is a cavity or tube



connected with the top of a steam cylinder. E a similar pipe, passing to the condenser; and F a third pipe leading to the bottom of the cylinder. Each of these pipes opens into D. When the valve is in the position represented, there is a communication within-side the valve, between the top of the cylinder and the condenser. The steam, therefore, in that part is escaping, while a supply is rushing by the bottom hole into F, that is, under the piston. Rushing down the valve to the bottom of the case will reverse these communications, letting off the steam from F and giving a fresh supply to C.

DAGUERRETYPE. A process invented by M. Daguerre, a Frenchman, by which, delineations of views, portraits, &c., are taken with the greatest conceivable accuracy, without the aid of artistical genius in drawing, by means of reflection from the images themselves, when illuminated by a strong solar light. The process may be understood as follows:—A sheet of copper, plated with silver, is made extremely bright and clean. It is then exposed in a well-closed box to the vapour of iodine; when become of a slightly-yellow color, the plate is withdrawn and placed in a box camera obscura, and preserved from the action of light till the box is offered to the proper object or landscape to be represented. When this is the case light is admitted, and the objects become delineated on the silver plate, though very faintly: to bring them out with greater strength, the plate is next submitted to be acted upon by the vapour of mercury in another box. The plate being put in the box at an angle of 45°, and after some time it being taken out, must be washed with the hypo-sulphite of soda, and finally with warm water, when the picture will be clear, and not alterable by the further action of the light.

DAIS. An elevated part of a floor, or a platform in a hall, or banqueting room.

DAHLINE. (See *Datiscine*.)

D'ALEMBERT'S PRINCIPLE, in *Mechanics* is this. If several non-elastic bodies have a tendency to motion, and in directions which they are constrained to change, in consequence of their reciprocal action on each other, then these motions may be considered as composed of two others; one which the bodies actually take, and the other such, that had the bodies been acted upon by it alone, they would have remained in equilibrium.

DAM. A small dock or reservoir, in which the water of mill streams is accumulated; also an embankment of stone or timber raised for the purpose of turning the direction of a stream of water, so that it may be thrown upon a particular object.

DAMASKEENING. The art of ornamenting iron, steel, &c., by making incisions upon its surface, and filling them up with gold or silver

wire; chiefly used in enriching sword blades, locks of pistols, &c

DAMASCUS STEEL. A particular fine kind of steel of a streaky mottled appearance, used for the manufacture of the best sword and scymitar blades, of which a great trade was once carried on at Damascus.

DAMPER. A flap, or sliding piece of iron, which being raised, depressed, or more or less drawn out, increases or diminishes the draught of air in the flue of a furnace.

DAMPS. The permanently elastic fluids which are extricated in mines, and are destructive to animal life; are called damps by the miners. The principal are choak damp, or carbonic acid gas, and fire damp, or carburetted hydrogen.

DAN. A small truck used in mines, for the conveyance of coals to the pit's mouth.

DANCING IMAGES. An electrical experiment, to show the effects of electrical attraction. The apparatus necessary, is a pair of plates of metal, or wood covered with metal. The upper one, which is rather the smaller, is attached by a wire to the prime conductor of the machine; the other plate is placed upon a stand connected with the ground, so as to be three or four inches distant from the former: when figures of pith or paper are placed on the lower board, and the upper charged by turning the machine; the figures will dance up and down between the two plates.



DANCING PITH BALLS. An experiment illustrating electrical attraction. It is per-



formed thus:—Fasten to the prime conductor of the machine a pointed wire. Turn the handle, and hold a tumbler, previously warmed, over the wire. When charged with the fluid, which it will be in two or three minutes, turn it down over some small balls made of the pith of the elder tree, lying upon the table. These will immediately fly up and down till the glass is discharged.

DACTYLIOGRAPHY. A description of engraved finger rings and precious stones.

DACTYLIOLOGY. The science which describes or treats upon the history, nature, and qualities of engraved gems for finger rings.

DANIELL'S CONSTANT GALVANIC BATTERY. A galvanic battery, which may be considered, as compared to previous inventions, constant, its action lasting unimpaired for a great length of time. It consists of a copper vessel A, holding about a pint of liquid. In and through the centre of the bottom of this is a cork E, (fig. 2,) with a syphon tube attached. On the top end of the cork is tied a long narrow bladder D, the upper end of which is also tied around a cork, piece of wood, or something similar C, which rests upon the edge of the copper vessel; within the whole is a rod of zinc B, attached to which is a wire G, the outer copper vessel having soldered upon it a similar wire. At a short distance down the copper vessel is a ring-shaped shelf F. Fig. 1 is the external appearance of the battery, the wire from the copper being marked C. To use the instrument, fill the space between the outer vessel and membrane D, with a saturated solution of sulphate of copper, and put some crystals of the same salt on the shelf F, and suffer water, acidulated with sulphuric acid, to trickle slowly into the inner vessel, around the zinc; any thing placed between the wires will be subjected to a galvanic action. When the inner vessel is too full, or becomes loaded with the oxyde of zinc, the liquid will pass off through the syphon tube.

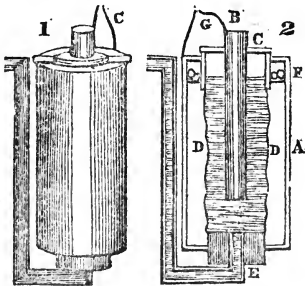

DANIELL'S HYGROMETER. An instrument for ascertaining the dew point and other meteorological phenomena. The lower ball is of black glass, about an inch and a quarter in

diameter, and is connected by a bent tube with the other ball, which is of the same size, but of white glass, and covered with a piece of linen. Withinside the longer arm of the tube is fixed a delicate thermometer, and another delicate thermometer is affixed to the stand. Sulphuric ether, enough to fill three-quarters of the cavity of one of the balls, is introduced, then boiled, and the tube sealed. To ascertain the dew point, incline the hygrometer till all the ether is in the lower ball. The instrument is put down so as to stand steadily, and the temperature of the air noted on the thermometer on the stand. Ether is poured on the muslin, until the cold produced by its evaporation, so cools the temperature of the lower ball, that dew is deposited on its surface. The degree of the thermometer within, shows the accurate dew point.

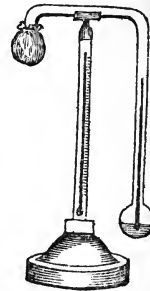

DANIELL'S JET. A contrivance to ensure the safety of the oxy-hydrogen blow-pipe, which it does to a certain extent; that is, while the pressure upon the bladders which holds the gases is equal to both.



A bladder of oxygen is screwed on to the end A, and when the stop-cock of the bladder is turned, and pressure applied, the gas passes through the centre of the jet. A bladder of hydrogen is screwed upon C, and passes along a tube, which is on the outside of, and completely incloses the oxygen tube, so that the two gases are only in contact at the extremity B, where they both issue.

DANISH BALANCE. A kind of steel yard, in which the counterpoise or weight, is fixed, but the fulcrum or support, is moveable. It is represented below:—



DAPHNIN. The bitter principle of *daphne alpa* and *daphne mezereon*.

DARCEY'S ALLOY. (See *Fusible Alloy*.)

DARK TENT, or CHAMBER. The same as the camera obscura, (which see.)

DATA. In mathematics, certain quantities which are given or known, and by means of which other quantities which are unknown are to be determined.

DATISCINE, or DAHLINE. A vegetable principle, which differs only from starch in not having a blue, but a yellow color, when iodine is added to it. It is produced by boiling with water the roots of angelica, dahlia, sunflower, &c., evaporated till a pellicle forms on the surface, and then left to cool; when datiscine will settle in the form of a white powder.

DATUM. The singular number of data, (which see.)

DATURINE. An alkaloid obtained from the *datura stramonium*.

DAVY'S, (SIR H.) ANALYZING APPARATUS. An instrument under this name is sold by the chemical instrument makers, and is adapted to analyze gaseous products. A is a vessel, in which the substance to be examined is placed, either alone, or with water, or some liquid which is necessary to decompose it. If a gas arises from it, that gas would pass to the vessel B, where it may be absorbed, or purified, according to circumstances; from thence it would pass to C, where the final result may be examined. The vessel D is a safety vessel, to prevent the fracture of A by the too great pressure of the gas formed within.

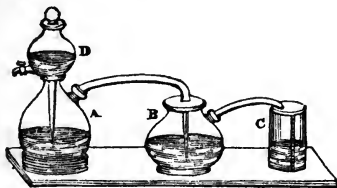

DAVY'S, (SIR H.) DECOMPOSING APPARATUS. For the decomposition of water under

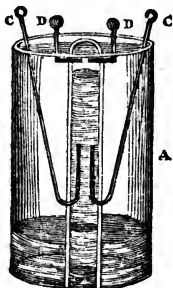

oil, and by electricity. A is a glass vessel, with a glass tube closed at the top, in the middle of it. D D are the two wires to communicate the shock to explode the gases formed. C C the wires connected with the galvanic battery which decomposes the water.

DAVY'S, (SIR H.) FURNACE. A chemical furnace, recommended and used by Sir H. Davy. It is made wholly of sheet iron, the fire-place being lined with fire-brick. The fender below contains, first, the lower part of the furnace, as represented. B is the ash-hole, the upper part above B being the place for the fire. I is a door covering a hole leading to the fire, for the introduction of muffles, tubes, &c. A is a smaller cylinder, which fits upon the former part, having a door for the supply of fuel, and a chimney to carry off the fumes. C is a third vessel, which may be lifted off and on, as occasion requires; the still, retorts, &c. are placed here. The chimney F H runs through a square iron trough G, which is used as a gentle sand bath.

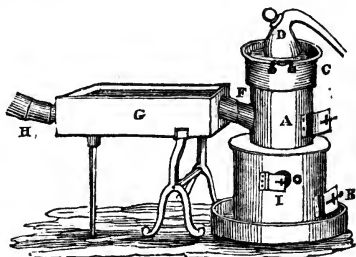

DAVY'S, (SIR H.) SAFETY LAMP, or MINER'S FRIEND. An instrument to prevent the fatal explosions of fire-damp, to which miners are exposed when working in coal mines. It acts upon the principle, that the flame will not penetrate a fine wire-gauze: if, therefore, the flame of a lamp be surrounded with wire-gauze, no danger is to be apprehended, even when surrounded by explosive mixtures. A and B represent the lamp in section, and according to its usual external appearance. The other letters apply to both figures. C is the cover of wire-gauze. D the foot of the lamp, containing the oil and cotton. E a tube for the supply of oil. G the flame of the lamp, in the front of which is a plano-convex lens, to increase the light. H is a stout wire frame-work, by which the lamp is held; and I is a hook to hang to the miner's clothes, that the lamp may keep steady. Around the wick is a small coil of fine platinum wire, the use of which is as follows:—When the lamp is carried into any mixture of gases where there is no oxygen, the flame goes out, and thus warns the miner; when he retires from the dangerous locality and comes into a purer air, the platinum

which has still remained red-hot, re-lights the lamp.

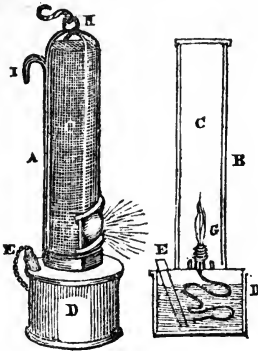

DAVY'S, (SIR H.) TUBE HOLDER. A stand of tin, with a spring socket, to hold a eudiometer tube, when the gases are to be exploded. This simple instrument should have the foot made like a tin dish, in order that it may catch any mercury or other liquid that may be spilt by the explosion. The eudiometer tube may be taken out, and put in from the top; the finger or a cork closing the lower extremity at the time.

DAVY'S, (SIR H.) RADIATING APPARATUS. For showing the effects of the radiation, from charcoal points, or incandescent wire, when in vacuo. The figure will explain itself.

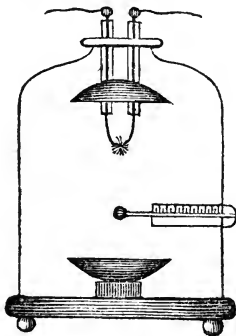

The poles of a galvanic battery are attached one to each of the upper wires. These are inclosed in glass tubes, which project into a glass jar, which is supposed to be placed on the table of the air pump, and exhausted of air. Within the glass is a concave mirror, a thermometer, and the lower tips of the wires, or charcoal points.

DAY. The bay or light of a window, between two mullions, that is, one of the compartments of a Gothic window, measuring it from the tracery at top to the sill below.

DAY. In astronomy, is that portion of time which elapses between two successive transits of the sun over the same meridian, the hours being counted from the one transit to the other, or from 1 to 24; this is the *civil day*. In common conversation, day is the period of time during which we have the sun's light, and used in contra-distinction to *night*, or the time of darkness. A *solar day* is the exact time from one transit of the sun over a meridian to its return to the same point again. This varies slightly at different times of the year, sometimes being rather more, and at others rather less than the ordinary or civil day; on account of which, the time as indicated by clocks is at certain seasons before that shown on a sun-dial, at other seasons proportionably behind. A mean between all the differences of the solar days, is called mean solar time.

DAY, SIDERIAL. The time in which the earth makes one complete revolution on its axis, as indicated by the two successive transits of a star over a certain meridian. The sidereal day is about 4 minutes less than the mean solar day, the difference arising from the motion of the earth in its orbit. Hence there are 366 sidereal days, and 365 solar days in a year.

DAY TELESCOPE. (See *Telescope*.)

DAY AND NIGHT THERMOMETER. (See *Rutherford*.)

DEAD LEVEL. (See *Level*.)

DEAD LIGHTS. The shutters which close over the windows of a cabin in stormy weather.

DEAD WATER. The still water always observable immediately behind the stern of a ship.

DEAD RECKONING. An account of the progress of a vessel, showing the courses steered by compass, with the distance in leagues, miles, &c., on each course. When lee-way, variation, &c. have been allowed for, it is called corrected dead reckoning. The term is used in contra-distinction to a reckoning obtained by celestial observations.

DEAFENING, or DEADENING. Filling up the interstices of partitions, floors, &c. with cork, or other material, for the purpose of preventing the communication of sounds from one apartment to another.

DEAL. The wood of the fir tree, as cut up for the purpose of building. It is of two kinds, white and yellow. The white deal is soft, and fit only for in-door work; the yellow, owing to its being filled with turpentine, is harder, stronger, and more durable when exposed to the weather. Deals are usually 9 inches wide and $2\frac{1}{2}$ or 3 inches thick.

DE BUTT'S DIFFERENTIAL THERMOMETER, is represented annexed. It consists

of a tube of glass, with a ball at each end, the lower ball being turned up, as in the figure, and a scale attached to the stem. The reason of the lower ball being turned up is, that it may hold a portion of air, without that air escaping into the tube, and thence into the upper ball. This instrument is either to be suspended perpendicularly, or supported on a stand. There being a difference in the volume of air in the two balls, one is more affected than the other by a change of temperature; hence the term applied to these instruments of differential thermometer. The liquid recommended is sulphuric acid, tinged with carmine; a fluid which easily evaporates, such as spirits, being inapplicable.



DEBRIS. The fragments of rocks, &c.

DE CAUS'S STEAM ENGINE. A kind of fountain, acting by the force of steam: useful to record now, only because of being the first application of the elasticity of steam, and its force when under a pressure.

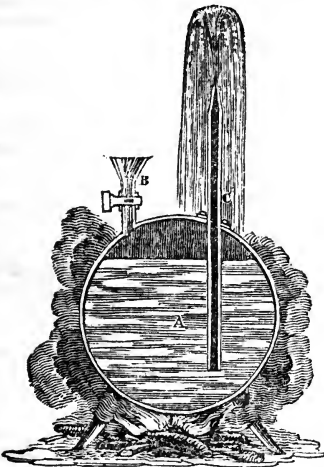

A globular vessel A is nearly filled with water by the pipe B. When thus supplied, fire is placed beneath the vessel until the water boils. The cock in B being closed, the steam will soon accumulate, and being at a pressure will drive the water up the pipe C.

DECANTATION. The action of pouring off the clearer parts of a fluid, by gently inclining the vessel after the grosser parts have been suffered to subside.

DECAGON. A geometrical figure, with ten sides and ten angles. If all these be alike, it is a regular decagon. To find the area of a de-

cagon, multiply its side by 7.6942088, that being the area of a decagon whose side is one.

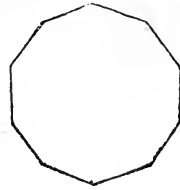

DECASTYLE. A building, of which the portico has ten columns.

DECIMAL. Any number increasing or decreasing by tens.

DECIMAL, ARITHMETIC. That part of the science of numerical calculation, which treats of decimal fractions.

DECIMAL FRACTIONS, OR DECIMALS. Such fractions as have 10, or some multiple of 10 for a denominator; for example 5 with a dot before it, thus $\cdot 5$ is a decimal, and signifies 5-10ths, or 5 parts out of 10. $\cdot 67$ is also a decimal, reckoning for 67 parts out of 100. $\cdot 433$ is so many parts of 1000; the number of cyphers belonging to the denominator being always equal to the number of figures which compose the decimal. The following is a decimal and whole number joined together, $1\cdot 25$, and which signifies $1\frac{1}{4}$, the decimal $\cdot 25$ meaning so many parts of 100; this is one-quarter of it.

DECIMAL POINT. A full point placed on the left hand of decimal fractions, intended to separate them from whole numbers when both are united, or to distinguish them as decimals when standing alone, as $5\cdot 7143$ and $\cdot 4038$.

DECIMAL SCALE. Any scale in which a certain distance is divided into ten equal parts. Scales of this kind are infinitely more valuable to the artist and builder in setting out or altering the size of drawings, than such as are divided into twelves, unless inches be indispensable. (See *Diagonal Scale*.)

DECLINATION. In astronomy, the distance of the sun, star, or other heavenly body, from the equator, either north or south. Similar therefore to latitude in geography.

DECLINATION. Parallel circles of. (See *Circles*.)

DECLINATION, Parallax or Refraction of, is such an arc of the meridian as is equal to the change produced in the declination by parallax or by refraction.

DECLINATION OF THE DORIC MUTULE, is the acute angle which the planes of the wall and soffit make with each other, which with the soffit or underpart of the mutule is lower at its projecting extremity than it is at its receding extremity where it commences.

DECLINATOR. An instrument used in dialling, for taking the angle or degree of slope of inclined planes.

DECLINERS, or DECLINING DIALS. Such dials as cut either the plane of the prime vertical circle or plane of the horizon obliquely.

DECLIVITY. A sloping or oblique descent.

DECOCTION. The operation of boiling; also the liquid which by boiling has been made to dissolve and imbibe any substance boiled with it.

DECOMPOSING APPARATUS. An instrument made of glass, wires, &c., to show the decomposition of water by galvanic action. It may be of two kinds; in one, the components of water, which are oxygen and hydrogen, are caught in the same tube, as in fig. 1. In the other instrument there is a tube for each, as in fig. 2.

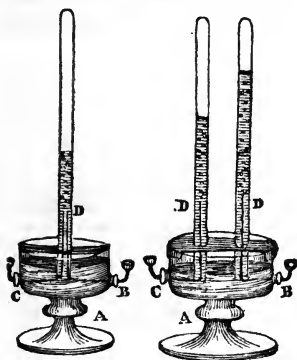

A is a glass vessel, furnished with a foot, and with two necks B and C. Through these necks are placed wires of platinum, one end of each wire being out of the glass cup, the other end projecting into the tube D, which takes off and on as required; thus in fig. 1, the inner ends of both wires are in the same tube; in fig. 2, in different tubes. To use the apparatus, fill A with acidulated water; also fill D with the same, and put it in its place over the wire; then pass a galvanic current through the wires, and the water between will be decomposed into its two elements, oxygen and hydrogen; the latter being half the oxygen.

DECOMPOSITION. The separation from each other of the constituents of a compound body; thus atmospheric air decomposed gives out oxygen and nitrogen. Decomposition may be occasioned by chemical action, however such action may be produced, whether by mixture, heat, light, electricity, &c. Hence we speak of electrical, chemical, and other decompositions. If one body or compound is alone acted upon, the decomposition of it is called *simple*; but if two substances act upon each other, so that they are both separated into their elements; and these elements again unite in any different manner, so as to

form substances of properties distinct from the first, the decomposition is called *double*. The former arises from simple or single affinity; the latter from double affinity or attraction.

DECOMPOSITION OF FORCES. The same as resolution of forces.

DECOMPOSITION OF LIGHT. The dividing a ray of solar light into its seven prismatic colors.

DECREMENTS are the small quantities by which a variable quantity decreases; and are thus opposed to *increments*, which are the small parts by which a variable quantity increases.

DECREPITATION. The crackling noise which several salts make when suddenly heated, accompanied by a violent throwing off of their particles.

DECUPLE. Ten-fold; a term of relation between quantities, one of which is 10 times as much as the other.

DECUSSION. Cutting or crossing.

DEFECATION. The freeing from impurities or dregs.

DEFICIENT NUMBERS are those the sum of whose divisors are less than the number itself; for example, the only numbers which will divide 27, without a remainder, are 9, 3, and 1. These added together make 13, or a number less than 27, which is therefore a deficient number.

DEFINITE PROPORTIONS. The exact proportions in which chemical substances unite with each other.

DEFINITE QUANTITIES. In mathematics, such as are of a certain and determined magnitude.

DEFINITION. A brief enumeration of such attributes of a thing as serve to distinguish it from all others.

DEFLAGRATING JAR AND SPOON. The first is a glass jar, with a large opening at the top for the insertion of a cork or stopper, through which is thrust in some experiments a metal spoon, shaped as in the cut; in other experiments, a coiled wire, a piece of charcoal, &c. The whole is intended to show that oxygen and other gases are supporters of combustion. Sometimes the mouth of the deflagrating jar is ground flat, that it may be covered with a piece of plate glass, instead



of being stopped with cork. The jar when in use stands in a basin of water or mercury, according to the gas operated upon.

DEFLECTION, or DEFLEXION. The turning any thing aside from its previous course, by some adventitious or accidental circumstance; also the bending of a beam of timber by its own weight, or by a weight placed upon it.

DEFLECTIVE FORCES are those forces which act upon a moving body in a direction different from that of its actual course; such is the attractive force of the sun to the earth in its orbit.

DEGREE. In algebra, is a term applied to equations to distinguish the highest power of the unknown quantity; thus, if the index of that power be 3 or 4, the equation is said to be of the third or fourth degree. In geometry, astronomy, &c., a degree is the 360th part of a circle, the length of the degree varying according to the size of the circle; thus, a degree of the equator is $69\frac{1}{2}$ statute miles; but a degree measured on a smaller circle is proportionably less. A degree is indicated by a small circle, and is sub-divided into 60 minutes, and that into 60 seconds; thus, 34° , $27'$, $55''$, signifies 34 degrees, 27 minutes, and 55 seconds. All angular measurement is taken in degrees. (See *Angle*.)

DEGREE of Latitude, is such a distance on a meridian as the observer must pass to vary his latitude one degree, or to increase or diminish the distance of a star from the zenith by one degree. It is by the exact measurement of a degree of latitude, or what is the same thing, a degree of the arc of the meridian, that the peculiar oblately spheroidal figure of the earth is determinable.

DEGREE of Longitude, is the space between two meridians, that make an angle of 1° with each other at the poles; thus meridians approach each other from the equator, and join at the poles. The degrees of longitude vary in every degree of latitude, until at either pole they become nothing—the poles therefore have no longitude.

DE LA FAYE'S PUMP. An hydraulic engine, of very simple structure, of considerable power, and with little friction.

A A A represent the arms of a wheel. These arms are hollow, and communicate at the centre with the barrel O, and project through the rim, opening there by the holes C C C. When the wheel is turned round by the action of the stream against the float boards B B B, it scoops up the water by the holes C C C, and as this turns round, the water passing along the channels A A, is finally deposited in O; running thence it is caught by the trough B, and may be conveyed afterwards to any situation where it is required. It will be seen that the water cannot be raised higher than the axis of the

wheel, but that is generally enough for the purposes of irrigation.

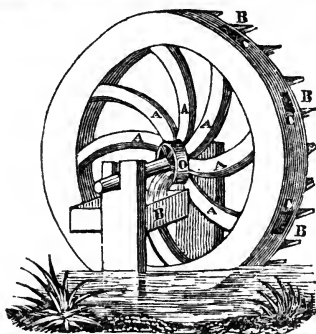

DE LA HIRE'S PUMP. A lift and force pump combined, which raises a like quantity of water both by its up and down stroke.

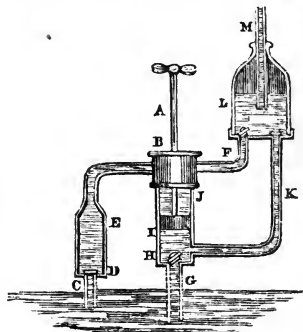

J is the working barrel in which the solid piston I moves up and down by the pump rod A. G is the feeding pipe, and H the stop valve upon it. K is a lateral pipe, proceeding upwards from the bottom of the working barrel, until it terminates in the under part of the air vessel I, where it is closed by a valve. This working barrel is closed at the top, the pump rod A working tightly through a hole at B. Consequently when the piston rod is depressed to expel the water from the lower part of the barrel into L, the vacuum formed above the piston is filled not by air, but by water from the vessel E, while a contrary stroke shuts the valve D, and forces the water above the piston into L by the pipe F.

DE LA RIVE'S FLOATING GALVANIC APPARATUS, consists of a coil of fine wire, about 3 inches diameter, A; the ends of this pass through a round cork B, and are terminated below; the one by a piece of zinc Z, the other by a piece of copper C—each about 1 inch square. This apparatus shows the magnetic polarity when put to float in a basin

of acidulated water; one side of the coil turning to the north; the other to the south. (For an improvement of this instrument, see *Marsh.*)



DE LA RUE'S GALVANIC BATTERY, is represented below:—

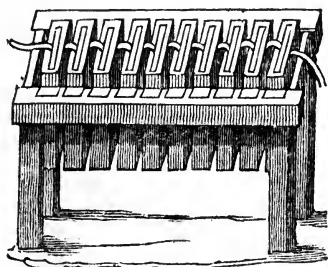

It consists of a series of copper cells, or square boxes. Each box is furnished with a plate of zinc, and the various boxes are arranged along a square frame, depending from it by lips or shoulders of copper. It is to be filled with a saturated solution of sulphate of copper, and some crystals of the salt placed in the solution, in order to supply the waste occasioned by the decomposition of the solution which arises from the galvanic action.

DELETERIOUS. Deadly or poisonous; as many plants, also the following and many other gases, chlorine, arseniuretted hydrogen, and sulphurous acid gas.

DELFT WARE. A kind of pottery, covered with a white glazing, which gives it an appearance of porcelain, such as the common plates, cups, basins, &c.

DELIQUESCENCE. The spontaneous melting of certain saline bodies when left exposed to the air, in consequence of the water they attract from it.

DELPHINIA. A vegetable alkaloid, discovered to exist in and which occasions the peculiar medicinal properties of delphinium staphysagria.

DE LUC'S DRY PILE, OR ELECTRIC COLUMN. Take a tube of glass, and after having prepared some 2 or 3000 pieces of paper, of copper or silver leaf, and of zinc leaf or foil,

and cut or punched them into circular pieces of the internal diameter of the tube; fill it by putting in first a piece of copper, then a piece of zinc, then a piece of paper, again copper, zinc, paper, and so on, until the tube is quite full. This would constitute De Luc's dry pile, and if the two poles are brought near each other by a wire attached to the upper end, and hanging downwards near to the lower end, a small pith ball will play between them, or be attracted first to one, and then the other alternately, (see fig. 1;) in which A is the pile—B the wire and ball; and C a fine silk thread, holding the pith ball. An instrument of this kind is commonly called the electric perpetual motion, (see *Melloni*,) from the long duration of its action. A pile of this description, of 2000 pairs of plates, has been known to go incessantly for twelve years, and even then stopped by an injury only. The other figure of the cut shows two such piles D D, with their lower ends terminated by bells F F; the letter E being the thread and balls. In a double tube of this kind, it is essential that the upper end should be in close contact with the discs of metal, and the order of copper, zinc, paper, be carefully continued throughout.

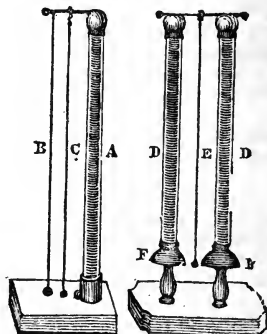

DEMITINT, is a gradation of color between positive light and positive shade; called also half tint.

DEMONSTRATION. In mathematics, a method of reasoning, whereby the truth of an assertion is shown by one or more propositions, the truth of which is already established, or admitted.

DENDROMETER. An instrument for measuring the altitude of trees; and in general terms, any contrivance for measuring the magnitude of objects at a distance.

DENOMINATOR. The lower term of a vulgar fraction: thus in $\frac{1}{2}$, $\frac{2}{4}$, $\frac{1}{8}$, &c., the denominators are 2, 4, and 8. If two or more fractions are placed together, having the same number to constitute the lower line of each, such number is called their *common denominator*.

DENSITY. Weight. Strictly speaking density denotes closeness of particles in any body; it being assumed that those bodies are the most dense in which the particles are more closely pressed together, or which contain, in proportion to their size, the greatest number of atoms.

DENT. The wire staple which forms the tooth of a card.

DENTELS, DENTILS, DENTICLES, or BLOCKS. Square, or tooth-like ornaments, cut out of a square moulding; common under the cornice of Ionic, Corinthian, and Composite buildings. The range of them is often called the denticulated band or the block course; and a cornice so attended is a block cornice.



DENTICULE. The flat projecting part of a cornice, on which dentiles are cut.

DEOXYDATING RAYS OF LIGHT. In the decomposition of white light into the prismatic colors, it has been observed, that the violet end of the spectrum, and also a point just beyond this, occasion chemical changes more rapidly than the red and yellow rays; so that paper, imbued with the chloride of gold or silver, remains nearly unchanged in the latter place, but rapidly becomes blackened in and beyond the violet rays. These, therefore, are called the deoxydating rays, the change of color depending upon the reduction of the metal.

DEOXYDATION is the depriving a body of the oxygen which it contains: thus chlorate of potass, oxyde of manganese, and numerous other bodies part with oxygen when heated, and in proportion become deoxydated.

DEPARTURE. In navigation, is the difference of longitude the ship has made, between the place where the last reckoning was made and that which she has now arrived at.

DEPILATORY. Is the name of any substance capable of removing hairs from the human skin, without injuring its texture. The following is such a composition; it is called by the hair-dressers *roseate powder*—quick-lime 12 oz., starch 10 oz., orpiment 1 oz.—mix them together; put a small piece on the skin, wipe it off, and wash the part immediately.

DEPHLEGMATION. Any process by which bodies are deprived of water.

DEPHLOGISTICATED. A term of the old chemistry, implying deprived of phlogiston or the inflammable principle, and nearly synonymous with what is now expressed by oxygenized or oxygenated.

DEPHLOGISTICATED AIR. The same as oxygen.

DEPOLARIZATION OF LIGHT. The reducing or restoring a ray of polarized light to

its former state. If a slice of mica, tourmaline, selenite, or certain other crystals, be put so as to intercept a ray of polarized light, and then be turned round, it will be found that in two opposite parts of the revolution, the images cast by the ray of polarized light will become invisible. In this state it is said to be *depolarized*.

DEPRESSION. A sinking or pressing down; thus the depression of the pole is the apparent approximation of it towards the horizon as we sail towards the equator. The depression of the sun or moon is its distance below the horizon. The depression of the visible horizon is its apparent extension, either in consequence of our ascending an eminence, or else from peculiar states of the atmosphere. The word *dip* is often used in the same sense.

DEPTH. The third dimension of a solid, the others being length and breadth; or it is the distance of one object below another, as the depth of a well is the distance from the top to the bottom of it.

DERBYSHIRE SPAR. Flute of lime.

DESAGULIER'S STEAM ENGINE, invented about 1716, and adapted to the pumping of water only, it not being furnished with either beam or steam cylinder.

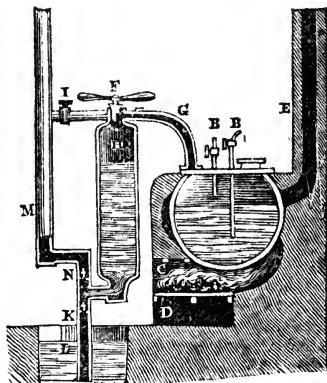

A spherical boiler is inclosed in brick-work. B B are the two guage cocks. C is the fire-place, and D the ash pit. E the chimney. F the four-way cock, to turn the steam off and on, and also to let in the water for condensation. G the pipe to convey steam from the boiler. H the condenser. I the injection cock and pipe. L the well of water. M the eduction pipe, to convey away the water raised by the engine. Steam being admitted to H, drives the water in L before it, through the valve N, stopping up at the same time the valve K. When the steam is shut off, and cold water admitted, the removal of the steam pressure forces the

water of the well through K into H again, while the next admittance of the steam carries this fresh portion of water also into M, as in the first instance.

DESCENDING LATITUDE, is the latitude of a planet, in its return from the nodes to the equator.

DESCENT OF BODIES. The tendency to fall, or to move towards the centre of the earth.

DESCENSION. In astronomy, the contrary to ascension, it may be either right or oblique. *Right* descension, is the arc of the equator, which descends with the sign or star below the horizon, of a direct sphere. *Oblique* ascension, the arc which descends with the star, on an oblique sphere. The difference between this is called the *dis-*
ensional difference.

DESCRIBENT. In geometry, a line, or surface, which produces a plain figure by motion.

DESICCATION. Drying any thing, whether by evaporating the water contained in it, or by absorbing the water by the addition of any thing which rapidly attracts it.

DESIGN. An original sketch, or drawing, from which a building, or other work of art or genius may be executed by other persons.

DESTRUCTIVE DISTILLATION. When organized substances, or their products, are exposed to distillation, until the whole has suffered all that the furnace can effect; the process is called destructive distillation.

DETACHED. In painting, such figures, buildings, trees, &c. as appear standing out from the back ground in a natural manner, the other parts appearing in their proper relative situations.

DETAILS. Such drawings, models, and instructions, as are sufficiently large and carefully executed to show the exact particulars of the more minute parts of a building, a machine, &c.

DETENT. Something that locks or unlocks a movement; the word is chiefly applied to clock-work. That particular catch which falls into the striking wheel, and stops it from striking more than the right number of strokes, is called the detent; so also is any similar part which belongs to an escapement.

DETERIORATION. An act, or cause, by which any thing is damaged or injured.

DETONATING OIL. Chloride of nitrogen, one of the most dangerously explosive compounds known, a drop no larger than a grain of mustard seed occasioning a dreadful detonation when touched with phosphorus, or either of the fixed oils. It may be made thus:—partly fill a basin with a solution of 1 part of sal-ammoniac to 12 of water, and invert over it a tall jar of chlorine. A yellow oily film will soon form on the surface, which is the chloride of nitrogen.

DETONATING POWDERS. Certain chemical compounds, which on being exposed to heat or friction, explode with a loud report. Of this description are gunpowder, the fulminates of gold, silver, and other metals. A common detonating powder may be made by triturating in a warm mortar, 3 parts by weight of saltpetre, 2 of carbonate of potass, and 1 of flour of sulphur. When thoroughly mixed together, a little of the mixture may be put in a ladle, and if suffered to heat gradually, it will explode with a terrific report.

DETONATING TUBE. (See *Eudiometer*.)

DETONATION. A sudden combustion and explosion.

DEVICE. An emblem, or metaphor, which represents one object, by another which bears some resemblance to it; such as the device on a crest, shield, &c.

DEVICES ON GLASS. If a number of spangles of tin-foil be pasted on a sheet of glass so as scarcely to touch each other, and an electrical current pass through them, by holding one end of the glass in the hand, and taking a spark with the other end; this spark will appear as a line of light, or a continued series of sparks, in the intervals between the spangles. A similar appearance is produced by strips of tin-foil properly connected at the end, as in fig. 2; and cuts made with a pen-knife across the strips so as to make an interruption in the circuit; *words* are thus made. If it be desired to make a complicated figure, or device, the tin-foil must be carried first along one side, then return by the other side of the glass, as in fig. 3, where the different sides are made by different colors in the cut.

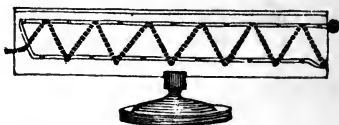

DEVIL. A machine for dividing rags or cotton, in the first process of paper making.

DEUTOXYDE, literally means the second oxyde; but is usually employed to denote a compound containing 2 atoms, or 2 prime equivalents of oxygen to 1 of metal: thus we say deutoxyde of copper and deutoxyde of mercury.

DEW. The moisture insensibly deposited from the atmosphere on the surface of the earth.

DEW POINT. The degree indicated by the thermometer, when dew begins to be deposited.

DEXTRINE, or BRITISH GUM. A matter of a gummy appearance, formed from starch, by the action of acids upon it. It is much employed by the French pastry-cooks and confectioners, and with us in the dressing of various textile fabrics, instead of gum arabic, for which it is a good substitute.

DIACOUSTICS. The properties of sound, refracted by passing through different media.

DIADROME. The swing of a pendulum.

DIAGLYPHIC. Such works of sculpture, engraving, &c., as represent the objects as sunk into the general surface; in opposition to anaglyphic.

DIAGONAL. A straight line which stretches across from one angle to another of a geometrical figure, not being either of the sides of it. The dotted lines in the following diagrams are diagonals of the respective figures; besides which, others might have been drawn from different angles:—

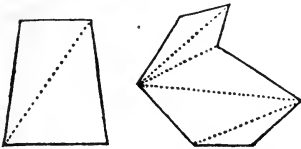

DIAGONAL BAROMETER. (See *Barometer*.)

DIAGONAL MOULDING. (See *Cheveron and Fret*.)

DIAGONAL MACHINE. A portable kind of reflective cosmorama, for viewing pictures. It is represented below:—

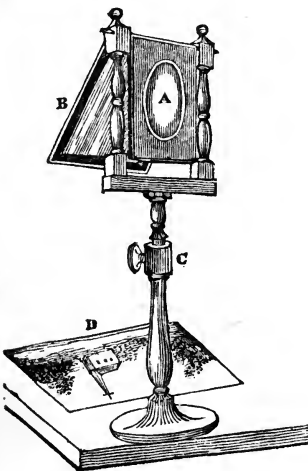

A is a large magnifying lens of about two feet focus. B a looking glass, suspended from the top of A, and moving so stiffly that it may be set to any angle, that of 45° is most usual. C is a socket and screw in the stand to elevate or depress the upper part of it. D the picture to be viewed. The light from the picture impinges upon the face of B; here it is reflected to A, and passing through A, reaches the eye considerably magnified.

DIAGONAL SCALE. A useful mathematical scale; so called, because the smaller divisions are ascertained by lines which run diagonally across the other divisions. It is usually made to measure the decimated numbers, thousands, hundreds, tens, and units. The whole scale being 1000, the chief divisions of it would reckon as 100 each. The sub-divisions of one of these parts, as shown at the end of the following cut, would be 10 each; and as the diagonal lines run from one 10 on one side of the scale to the next 10 on the other side of the scale, by counting on the longitudinal lines, reckoning them from 1 to 10 upwards, the odd number of units may be also easily ascertained.



DIAGRAM. In mathematics, an outline representation of a body, or of the properties and progress of a mathematical demonstration.

DIAGNOSTICS. The art of design, or drawing.

DIAL, or DIAL-PLATE. The face of a clock or watch, over which the hands move, and upon which the figures denoting the hours are delineated.

DIAL, or SUN-DIAL. An instrument serving to measure time, by means of a shadow cast by the sun from a rod, stile, or gnomon, fixed upon the dial.

DIALLING. The art of drawing sun-dials, so as to indicate the exact solar time. The principles of dialling may be understood by imagining a hollow sphere of glass with 24 lines painted upon it as meridians, one for each hour of the day, in one of which the given place is marked; for example, London, supposed at the point E, and at the equator, on the same meridian, is marked XII., and also on the opposite one; and on all the other meridians, the other hours in regular order; these would be the hour circles of London. Then, if the sphere had an opaque axis, as A B, the shadow of the axis would fall upon every meridian and hour, as the sun came to the plane of the

opposite meridian. If, then this sphere were cut in two by a solid plane D C, in the rational horizon of London, the shadow of part of the axis above the plane would be thrown across the plane, forming straight lines from the axis to the various meridians, the figures proper to each meridian being painted on these lines. The globe may be taken away, but the axis remaining would nevertheless indicate on the dial now formed, the true solar time: this is called a horizontal dial, but upon precisely the same principle a vertical or other dial may be formed.

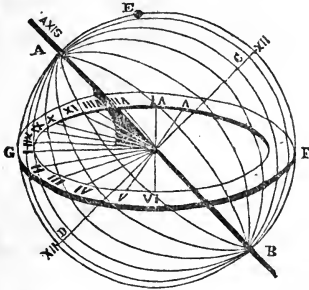

DIAMETER. A straight line which cuts a circle into two equal parts; (see *Circle*.) The diameter of a *column* is the thickness of the shaft, measured at the bottom. Its *diameter of diminution* is measured across the shaft at top. An ellipse has two diameters; the transverse, which measures from end to end, and the conjugate, or the distance from side to side.

DIAMOND. A precious stone, which is carbon in a state of crystallization. It is the hardest known substance, and therefore, when powdered, is used for grinding other stones scarcely less hard, and which nothing else would cut. When polished, which it may be by its own powder, it shows so great a power of reflection that a beautiful play of colors is seen upon the surface. It is difficult to inflame, but when once ignited, it continues to burn with a steady reddish light.

DIAMOND FRET. An architectural ornament so called, and represented as follows:—

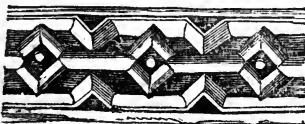

DIAMOND MICROSCOPES. Microscopes, the object glasses of which are formed of diamonds, ground of a lens-like form. The light of this lens is said to be superior to that of any compound microscope whatever, acting with the same power and the same angle of aperture.

DIAMOND SPOTTED JAR. A Leyden jar, which, instead of a continuous coating, is covered with diamond or other shaped pieces of tin-foil, just touching each other. When a jar like this is discharged in a darkened room, it presents a beautiful luminous appearance. In making it, observe to cover the bottom wholly with tin-foil, both inside and out; then place the diamond spots on the inside first, so that they shall not quite touch each other, and afterwards, stick the outer ones so as exactly to cover those within; they will, therefore, have an equal space between each corner, at which the luminous sparks will be seen.



DIAPER. Panelling, filled up with arabesque gilding and painting, or else carved in low relief. Walls, both external and internal, are often diapered, particularly the buildings of the thirteenth and fourteenth centuries.

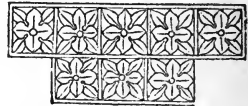

DIAPER. The name of a kind of cloth, used chiefly for table linen.

DIAPHANTINE ANALYSIS, OR PROBLEMS. In algebra, are certain questions relating to square, cube, &c. numbers, and rational right-angled triangles, the properties of which were first discussed by Diaphantus.

DIAPHONICS. The same as diacoustics.

DIASTACE. A substance extracted by water from crushed malt, and precipitated from that solution by alcohol.

DIASTYLE. A term used by Vitruvius, to signify a space between two columns, equal to three diameters.



DIATHERMATOUS. A term to designate those bodies which readily allow of the passage of radiant heat; for example, glass, alum, the sulphate of copper, &c., though pervious to light, entirely or very nearly intercept radiant heat: yet rock salt, rock crystal, &c., suffer its ready transmission; these last then are diathermatous.

DIE. A cube; the term is applied in architecture to any square or cubical part, as the trunk or naked part of a pedestal, between the base and the cornice. In the

arts, a die is a stamp, or reversed impression of a coin, medal, or other similar object, made for the purpose of impressing the device or motto cut out on the surface of it upon a piece of metal prepared to receive that impression. Thus, the coin of the realm, figured buttons, and numerous other small articles are placed and stamped between dies.

DIFFERENTIAL. In the higher geometry, is an infinitely small quantity, or part of a quantity so small as to be less than any assignable one.

DIFFERENTIAL CALCULUS, is a method of differencing quantities, or of finding an infinitely small quantity, which being taken infinite times, shall be equal to a given quantity; or it is the arithmetic of the infinitely small differences of variable quantities.

DIFFERENTIAL GALVANOMETER. Two wires of equal size and length are twisted together so as to form a compound wire, which is coiled around a compass needle, and the four extremities of the wires are immersed in four cups filled with mercury. By this means any two currents that are to be compared with each other may be sent in contrary directions through the wires. These opposite currents acting upon the needle under precisely similar circumstances, will, if they be equal, exactly counteract each other, and the needle will be undisturbed. If the currents be unequal, the needle will be influenced accordingly.

DIFFERENTIAL THERMOMETER. (See *Air Thermometer, Ætherioscope, &c.*)

DIGESTER. A kind of boiler, invented by Mr. Papin, for raising water to a higher temperature than the common boiling point, 212°. This is effected by forming a vessel like a common iron saucepan, with a cover, which fits tightly on, so tight indeed, that steam cannot escape. The cover is furnished with a safety valve.

DIGESTION. The slow action of a solvent upon any substance.

DIGESTIVE SALT. Muriate of potass.

DIGIT. In arithmetic, any one of the ten numerals, 1, 2, 3, 4, 5, 6, 7, 8, 9, 0. Digit is also a measure equal to three-fourths of an inch; and also a measure by which the quantity of an eclipse is ascertained. Thus the disc or face of the sun and moon is supposed to be divided into twelve digits; and therefore, according to the proportion of the sun or moon's face, which may be obscured, we say that it is eclipsed 8, 10, 11 digits, and so on.

DIGLYPH. A tablet with two channels cut upon it. (See *Triglyph.*)

DILATATION. The expansion of a body into a greater bulk by its own elasticity: thus, if an elastic body be compressed, upon the pressure being removed it will dilate itself again.

DILETTANTI. An admirer or lover of the fine arts; or one who delights in their pursuits.

DIMENSION is either length, breadth, or thickness. A line has only one dimension, length; a surface, two dimensions, length and breadth; and a solid, three, as length, breadth, and thickness.

DIMINISHED BAR, of a window sash; one that is thinner on the inner edge than where the glass touches it. It is thus cut in order to give it a lighter appearance.

DIMINUTION OF COLUMNS. The continued contraction of the diameter, from the base to the top of the shaft.

DIOPTRIC TELESCOPE. (See *Refractive Telescope.*)

DIOPTRICS, or ANACLASTICS. The properties of refracted vision, which investigates and explains the effects of light refracted by passing through different media, as air, water, glass, &c.

DIORAMA. An exhibition of a painting, seen through a darkened opening, which having the effect of confining the sight and attention to the objects of the picture, makes it appear more natural than under ordinary circumstances; while the effect is heightened by the variety and quantity of light thrown upon the face of the picture by means of red, yellow, and other colored blinds drawn before the window, which illuminates the picture.

DIP OF THE MAGNETIC NEEDLE. If a finely balanced bar of steel be magnetized, the north pole of it will, in this latitude, dip or droop downwards, till it stands at from 70° to 75°, varying a trifle annually. This is called the dip of the needle, and is owing to the attraction of the earth upon that pole. When the same magnetized needle is carried further north, it dips still more, till it stands perpendicular at the north magnetic pole of the earth, the south pole of the magnet will be downwards; but on the equator, as both poles of the dipping needle are attracted equally, but in contrary directions, the needle stands horizontally.

DIP OF THE HORIZON. (See *Depression.*)

DIPPEL'S ANIMAL OIL. An oily matter obtained when horns are distilled in a retort: rectified, it becomes colorless, aromatic, and as volatile as ether.

DIPTEROS, or DIPTERAL. A temple, having a double range of columns around it.

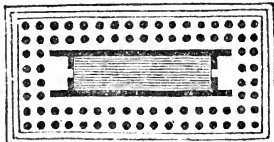

DIPPING NEEDLE. A magnetic needle suspended so that it is capable of a vertical motion, thereby being enabled to accommodate itself to the earth's attraction; though having no horizontal freedom of motion, it is not influenced to turn north or south.

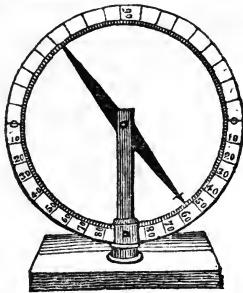

A needle thus suspended, is usually surmounted, or to oblique; as direct proportion, a direct ratio, direct rays, vision, &c. A *direct dial* is one that points directly to any one of the cardinal points, and is hence called *direct east, west, north, or south dial*, according to the point to which it is directed.

DIRECT. Straight, in opposition to inverse, or to oblique; as direct proportion, a direct ratio, direct rays, vision, &c. A *direct dial* is one that points directly to any one of the cardinal points, and is hence called *direct east, west, north, or south dial*, according to the point to which it is directed.

DIRECTION. In astronomy, the motion and other phenomena of a planet, when moving direct, and not retrograde in its orbit. The *line of direction* in gunnery is the direct line in which the piece is pointed. In mechanics, it is the line in which a body moves, or in which a force is applied. The *number of direction* in the calendar is the number of days that Septuagesima Sunday falls after the 17th of January.

DIRECTION, Quantity of. Synonymous with momentum.

DIRECTRIX, or DIRIGENT. In geometry, a term, expressing the line of motion, along which a disribent line, or surface, is carried in the formation of any plane or solid.

Disc. A circular flat piece of stone, wood, metal, &c., of which the thickness is not considered. The face of the sun, moon, and other heavenly bodies, from their appearing flat, are also called discs.

DISCHARGE. In building, a term applied to a brick wall or post, when trimmed up to a piece of timber overloaded in its bearing, in which case the wall or post is a discharge to that bearing.

DISCHARGE, Electrical. The sudden restoration to their natural condition of the opposite parts of a body, the electrical fluid of which is disturbed: thus, the two sur-

faces of the glass of a charged Leyden jar are in different electrical conditions; when these surfaces are made to unite by means of a conducting body, which touches both of them, their natural quiescent state is restored, and a discharge takes place.

DISCHARGER, Universal. (See *Henley*.)

DISCHARGING ARCH. An arch formed in the surface of a wall, to relieve the part beneath from some part of the superincumbent weight; often used over openings.

DISCHARGING ROD. A rod of metal, terminated by balls, with or without a glass handle, used to discharge a charged electrical jar or battery. The common kind is merely a bent wire, with a ball at each end, as A. The better sort, or the jointed discharger, is made with a glass insulating handle, and a rule joint, that the wires may be made to recede from each other, more or less, according to the convenience of the operator, as at B.



DISCHARGING ROD, Luminous. An electrical instrument, formed of a tube of glass, with an *iron chain* running through it, each end being terminated by a brass cap or ball. When a Leyden jar is discharged by this rod, a brilliant spark is perceived at every link of the chain, and the whole seems like a continued stream of fire.



DISHED WHEELS. Wheels which are not upright or perpendicular to the axle-tree; but such as are closer together below than at the top, as the following:—



DISH OUT, or DISHING OUT. Any kind of coved or groined work, formed of wooden rafters, which are afterwards to receive lath and plaster, therefore synonymous with cradling.

DISSOLUTION. The separation of a body into its minute and ultimate parts or atoms.

DISPERSION. A scattering or dissipation of the particles of any thing. In optics, the same as divergence; thus, the rays of light are dispersed from, or diverge from a luminous body; and the point from which rays of light diverge from the focus of a lens, or the direct emanation of them from a substance which is luminous, is called the point of dispersion.

DISTANCE OF A PICTURE, OR POINT OF DISTANCE. In drawing a picture according to the rules of perspective, that line which passes from the point of sight to that part of the picture which is exactly opposite to it. It is, therefore, the principal visual ray, or the shortest line that can be drawn from the eye to the perspective plane.

DISTANCE. In painting, the degree of remoteness of the objects in a picture is divided into three parts, called the remote distance, the mid-distance, and the foreground, each of which varies from the other in its clearness of detail, arising both from drawing, size, and tint.

DISTEMPER. In painting, is the mixing up and using various colors with size, the white of egg, paste, gum, or other glutinous substance, in order that they may adhere, so as not to be rubbed off when touched. Coloring, by powders mixed with water only, is called *liming*, and if with oil, oil painting, or simply painting; when on a small scale distemper is called body color painting.

DISTILLATION is a process by which a fluid, or portion of a fluid, is converted into vapor by means of heat, and that vapor returned into a state of fluidity by cold. (See *Still*.) Distillation is applied to the ready separation of fluids from each other, when there is a chemical union between them, and when one is more volatile than the other; thus, beer when distilled, yields a spirit mixed with water, and a re-distillation of that spirit renders it more pure by the abstraction of the water from it.

DITRIGLYPH. An interval between two columns in the Doric order, admitting two triglyphs.

DIVERGING LINES, OR RAYS. Such as are continually increasing in their distance from each other; for example, the rays of light from a candle diverge from each other in every direction from the surface of the flame.

DIVERGING SERIES. In algebra and arithmetic, is such a series as diverges more and more as it proceeds.

DIVIDEND. (See *Division*.)

DIVIDERS. A small pair of compasses, and such as are adapted to set off and describe mathematical figures.

DIVING. The art of descending to considerable depths under water.

DIVING BELL. A machine shaped some-

what like a bell, or more usually a square box of plate iron, to enable persons to descend beneath the surface of water.

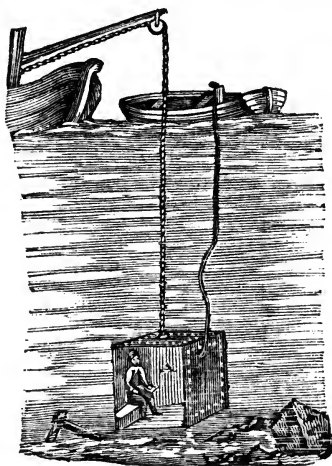

A represents the bell, the nearer side being supposed to be removed. It is open below, and is lowered into the water from a barge or boat. The water does not rise far up the inside, because of the air within pressing upon it. A person therefore descending in such a machine is in no danger of drowning, but as he requires fresh air to breathe, that within the bell would soon be unfit for respiration, and the diver would die, were it not for a pump which is also attached to the bell by means of a flexible tube; one or two men working this pump, which is upon the principle of the condensing syringe, are sufficient to keep up a continued supply of air to the diver.

DIVISION. One of the principal rules of arithmetic and algebra, by which is ascertained how many times one number is contained in another. The number to be divided is called the *dividend*, the number to divide it by is the *divisor*; the result of the division is called the *quotient*, and if any number is left over it is called the *remainder*. If the divisor be any number under 12, or, if being another number, the sum can be done in one line, it is called *short division*, but if in several lines, *long division*. When numbers of a single denomination are divided it constitutes *simple division*, while the division of a quantity consisting of several denominations is *compound division*.

DIVISOR. (See *Division*.)

DIURNAL. Any thing belonging to the day, in opposition to nocturnal belonging to the night. The *diurnal arc* is the apparent arc described by the planets, in consequence

of the diurnal rotation of the earth. The diurnal *motion* of a planet is the number of degrees, minutes, &c., it passes over in twenty-four hours.

DÖBEREINER'S LAMP, or the HYDROGEN LAMP. An instrument for producing an instantaneous light by the action of a stream of hydrogen gas on spongy platinum.

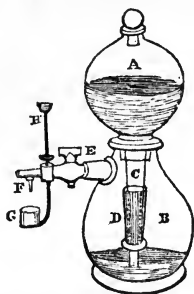

A and B are two glass vessels, fitting by a ground neck tightly upon each other; the upper glass terminates below by a tube C. The lower vessel has a peculiarly-shaped stopcock E attached to it. The lower end of the tube C is to have a piece of zinc slipped on it D; this may be supported by a cork below it. The vessel B is to be about three parts filled with sulphuric acid and water, and the vessel A, with its tube, zinc, &c. put in its place. The acidulated water now acts upon the zinc, producing hydrogen gas. This, when a quantity has been accumulated, exerts sufficient pressure upon the surface of the water in B, to drive a part of it up the tube C into A; as the water becomes driven up, the zinc becomes uncovered, and no more gas is formed. Upon turning the cock E, the gas passes out of the jet F, on to the spongy platinum in G. This becomes red-hot, and lights the gas, while the pressure being removed, the water sinks out of A, again covers the zinc, and produces a fresh supply. H is a wire attached to the cup G, to regulate the best position and distance of the platinum.

DOCIMASTIC ART. The art of assaying.

Docks. Inclosed excavations or basins, formed for the reception of shipping. There are two descriptions of docks—*wet docks* and *graving, dry, or repairing docks*. The former are extensive basins, formed adjacent to rivers and harbours, with which they are connected by means of a lock and flood gates, so that vessels may remain afloat at all times of the tide. Graving docks are only of sufficient size to hold one, or at most two vessels at the same time. This is the kind of docks in which state and other ornamental barges are laid-up to defend them from the the weather; and also in which the hulks of

ships and other large aquatic carriages are built and retained previous to launching.

DODECAGON. A geometrical figure with 12 equal sides and angles.

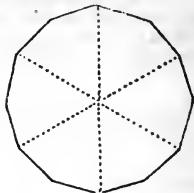

DODECAHEDRON. One of the five regular solids or bodies. It is contained under 12 regular pentagonal sides, and may be imagined to consist of 12 five-angled pyramids, whose apices meet in a point in the centre.

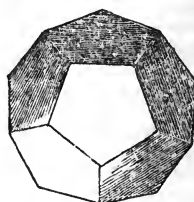

Dodecahedral crystals are often found without pentagonal faces, of which the following are two examples: in one, the faces are *rhomboidal*; in the other, *triangular*; the whole solid consisting of two hexagonal pyramids placed base to base.

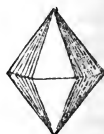
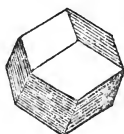

DODECASTYLOS. A building having 12 columns in front.

DOFFER. That part of a carding machine which takes the cotton from the cylinder.

DOG. A piece of small machinery which acts as a catch or clutch.

DOGS. Ancient fire-irons, used to rest the burning logs upon.

DOG AND DRIVER CHUCK. The name of a very common and exceedingly useful chuck; called also the *carrier* chuck, or the *driver* and *carrier*. It is of two parts; one of them (the driver) fits on to the mandril by a screw A, in the usual manner:—The body of it is perforated with a square hole, in which is a moveable elbowed iron rod D, which may be held fast by the screw F. On the point B is fixed the wood or metal to be turned, G, and near the end of this is screwed

the dog or carrier E; so that when the driver turns, the wood and dog turn with it.

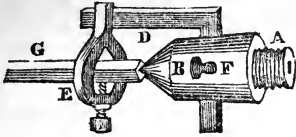

DOG-LEGGED STAIRS. A flight of stairs built as in most ordinary houses, not straight from bottom to top, nor yet built round a single newell or a well; but consisting of two or more straight portions, with winding stairs between them, so that one part of the staircase appears to fold upon, or to be nearly over the other.

DOG TOOTH. A peculiar ornament used in the Anglo-Norman buildings in the twelfth century.

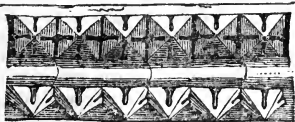

DOME. Similar to a cupola, but of a larger size. It is convex outside and concave within, as the dome of St. Paul's, &c. Domes are common in Indian, Mahometan, Moorish, and Italian buildings.

DOMESTIC ARCHITECTURE. The art of designing and executing buildings for domestic and private use, as villas, cottages, farm-houses, mansions, &c.

DOMINICAL LETTER, OR SUNDAY LETTER. One of the first seven letters of the alphabet, used in almanacs, and annexed to the Sundays of the year. It is intended to denote the day of the week upon which the 1st of January falls in each year.

DONJON. The principal tower of a castle, usually built upon a rising ground.

DONOVAN'S FILTER. A small apparatus, particularly adapted for the filtering of easily vaporized and pungent smelting liquids.

It consists of two glass vessels connected by a tube, made air-tight by perforated corks at the union of the tube and the two bottles. The upper vessel terminates in a conical pipe, ground into the lower one, and into which is stuffed a piece of coarse linen. This apparatus is also particularly useful in filtering those liquids which are apt to absorb carbonic acid from the atmosphere, as the solution of potass, or those which are easily decomposed.

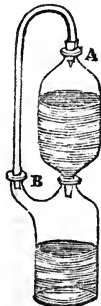

DOORWAY PLANE. The space between the actual door and the external arch in front of it; applied when the door is in a deep recess, as in many of the old churches, cathedrals, and castles.

DORIAN. Any thing in the fine arts, after the manner and style of the people of Doria.

DORIC. The second order of architecture, divided into the ancient Doric and modern Doric. In the ancient, the height of the columns is but $4\frac{1}{2}$ to $5\frac{1}{2}$ diameters; in the modern, 8 diameters. In neither are there bases to the columns, or ornaments on the capitals. The frieze is decorated with triglyphs and metopes; the latter, either plain or sculptured. The flutings of the columns are 20 in number, very shallow, and without any interval between them. The Parthenon, at Athens, is an example of the ancient; the Colosseum, of modern Doric.

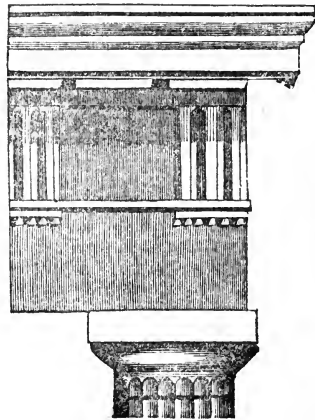

DORMER. A window set in the sloping side of a roof; so called, because usually belonging to a dormitory, or sleeping room.

DOS D'ANE. The ridge on the top of stone coffins.

DOVETAIL. A method of fastening together pieces of timber, by indentations or notches, resembling the tail of a dove or swallow; also a Gothic architectural ornament, so called.



DOUBLE AFFINITY. (See *Decomposition and Attraction.*)

DOUBLE AXLE AND WHEEL. (See *Crane, Chinese.*)

DOUBLE CONE. A particular kind of early Gothic architectural moulding, represented as follows:—(See *Cone*.)

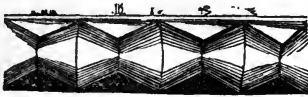

DOUBLE CONVEX, CONCAVE, &c. (See *Convex, &c.*)

DOUBLE DECOMPOSITION. (See *Decomposition*.)

DOUBLE REFRACTION. (See *Refraction*.)

DOUBLE TOUCH. A method of making magnets, so called. (See *Mitchell*.)

DOWELS. Pins of wood or iron, used to connect the joints of boards together. Floors are sometimes dowed; so are the pieces forming the heads of casks, the boards of wooden cisterns, &c.

DRAG. A term applied to any thing bearing down or rubbing upon another: thus, a door is said to drag when its hinges are so loosened that the lower edge rests on the floor; a drag is also an iron shoe, upon which the wheel of a carriage is made to rest when descending a steep hill, in order that the velocity it would acquire in moving down such a declivity may be checked by the extra friction occasioned by the drag.

DRAGON'S BLOOD. A brittle, dark, red colored resin, imported from the East Indies, the product of *ptercarpus draco* and *dracena draco*. It is insoluble in water, but soluble in alcohol. The solution imparts a beautiful red stain to hot marble. It dissolves in oils.

DRAGON'S HEAD AND TAIL. Particular astronomical characters, marked ♁ and ♁ , signifying the moon's nodes: the former, the dragon's head, signifying the ascending node, or the point where the moon begins to have north latitude; and the other, the descending node, or the commencement of south latitude.

DRAIN. A subterraneous passage for water.

DRAPEY. The dress of a figure in a picture, or a statue; while the word hangings properly applies to the curtains of a room.

DRAUGHT. In architecture, the representation of a building on paper, explanatory of the various parts of the exterior and interior, by means of plans, elevations, and sections, drawn to a scale, by which all the parts are represented in the same proportion to each other, as the parts of the edifice to be executed. In mechanics, the force or power necessary to move any machine, as a horse-mill, cart, plough, &c. In masonry, it is the chiselling of a narrow margin on the upper and lower edge, in order that when this part is thus reduced to a proper shape

and dimensions, the rest may be cut away more easily.

DRAWBRIDGE. A wooden floor, so constructed as to be lowered or raised at pleasure. The drawbridges of docks, &c., usually are drawn aside horizontally, rather than up and down.

DRAWING. The art of representing objects by means of lines or marks formed on any convenient surface.

DRAWING SLATE. (See *Black Chalk*.)

DRAW PLATE. A steel plate, having a gradation of conical holes, through which wires are drawn to be reduced and elongated.

DRESSED. In masonry, the trimming up of rough stones, that they may have a sufficiently smooth surface, to be placed in the wall, pavement, &c., for which they are intended.

DRESSINGS. Those parts of an edifice which are intended to set off or decorate the coarser work, as the mouldings of a doorway or window are its dressings; so are also the smooth quoins of a rustic wall, &c.

DRIFT. The tendency of any thing to force itself outwards or sideways; such as drift sand, the drift of an embarkment, the drift, or more properly the *thrust* of an arch, which in each instance signifies its lateral pressure.

DRIFT. In mining, a passage dug under the earth, between one shaft and another.

DRILL. In husbandry, a channel or small furrow for the reception of seed.

DRILL, DRILL BOW, &c. A drill is a small bitt, so formed, sharpened, and tempered, as to adapt it to penetrate hard substances, such as metal, ivory, &c., fig. A. It works by an alternate rotatory motion, put in action by a bow of cane or steel B, with a cat-gut string, which is twisted once round the stock, or pulley, of the drill; sometimes a drill is attached to the common, strong-made, bitt stock, when it is turned round by the hand of the workman, there being a pressure upon it above, C. A very valuable drill is that of the Chinese, represented below, Fig. D. EF is a bar of wood, with a hole in the centre, through which the spindle GH works. A rope is attached to E, passes through a hole in the top of the spindle at G, and is fastened at F.

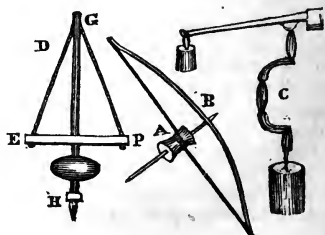

By turning E F the rope is twisted round the spindle, and E F drawn up towards G. Forcing E F down with the hand, the rope is suddenly untwisted, and the spindle, with the drill at the end of it, is turned round. With a little management it will, by the motion of the hands, wind itself up again, and consequently the boring action may be renewed.

DRILL HARROW. A small harrow used in drill husbandry, to be used between the drills or rows for the purpose of extirpating weeds, pulverizing the earth between the plants, &c.

DRILLING. The act of boring small holes by means of a tool which turns round, cutting by its point a hole through which it will just pass when finished.

DRIP. A projecting cornice; as for example, that which belongs to a Grecian pediment. Coping stones are often so called.

DRIPSTONE LABEL. WEATHER MOULDING. WATER TABLE. A large projecting moulding over windows, doors, and other openings, to throw off the wet.



DROPPING TUBE, or SEPARATING FUNNEL. A tube of glass, drawn to a point at one end, and furnished with a bulb in some part of its length, both ends being open. To use it, immerse the finer end in the liquid; to be taken up, and thrust it down; the liquid will rise until it finds its level withinside; then closing the upper end with the finger, it may be conveyed away. The partial or total removal of the finger occasions the fluid to drop or run from the lower end. Closing it again with the finger, stops the flowing; and thus, if there are two liquids in the tube, such as oil and water, the one may be separated from the other.



DROPS. (See *Gutta*.)

DRUG. A general name of commodities used for the purposes of medicine, dyeing, tanning, and various other arts.

DRUGGETT. A coarse, slight, woollen fabric.

DRUM. A term in machinery, applied to cylinders or barrels, around which endless straps, chains, or cords, are passed to communicate motion or power to other machinery. When such cylinders or drums are narrow in the direction of their axis, they are called *pullies* or *riggers*. In architecture, the drum is the centre of the Corinthian and

Composite capitals; called also the bell, or the basket.

DRY ROT. A term applied to that rapid decay of timber by which its substance is converted into a dry powder, which issues from minute tubular cavities, resembling the borings of worms. It is a fungous substance, or plant, which arises from the timber not having been properly deprived of its sap when drying; this sap, when it gets afterwards into a warm and moist situation, gives rise to the fungus. The only remedy for this pest of ship building is, to impregnate the timber before it is used, with corrosive sublimate, a salt of iron, alum, or other antiseptic. (See *Kyan*.)

DRY POINT. A term used by the engraver to designate a more or less obtusely pointed needle, with which fine lines are scratched upon a copper or steel plate, either as an outline, previous to the use of the graver, to put in delicate work where depth is not required; or to touch up such parts of an etching, &c. as require a little extra shade given to them.

DUBBING. Making good the decayed part of a wall, previous to the whole being pointed, or the joints of the bricks filled up with fresh mortar.

DUCTILITY. The extensibility and cohesion of the particles of a metal, which enable it to be drawn out into wire without breaking.

DU FAY'S ELECTRICAL HYPOTHESIS, is that there are two electrical fluids, opposite in their nature; one of which he called the *vitreous* fluid, from its becoming most apparent by the friction of glass; the other, the *resinous* fluid, as being produced by resinous substances. These two, assumed to be distinct fluids, correspond with the positive and negative states of the Franklinian hypothesis of a single fluid. One of them is never disturbed, unless the other be equally so; and, consequently, when one is set at rest, the other is no less quieted. The theory of there being two fluids is maintained by numerous philosophers, particularly the French.

DUHAMEL'S METHOD OF MAKING MAGNETS. Lay the two bars of steel which are to be magnetized parallel with each other, as A, C, and connect their extremities by two shorter bars of soft iron, D, D, so as to form altogether a right-angled parallelogram. Then take two parcels of bars already magnetized, B B, the separate bars of each parcel being placed with their respective poles in the same direction, and firmly tied together. Bring the opposite poles, N, S, of these bundles, into contact over the middle of one of the bars, holding them rather slanting, as shown in the figure; draw them gradually to the extremity of the bar, repeat this several times, and pursue the same method with the

other bar, when both A and C will become permanent and strong magnets.

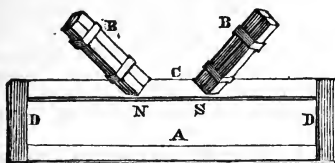

DULCIFIED SPIRIT OF NITRE. Nitrous ether; used by the distillers to communicate to British brandy the peculiar aroma which that from France is naturally imbued with.

DULCIFIED SPIRIT OF SALT. Muriatic ether, or hydrochloric ether.

DUNGING. A term used by calico printers to signify a process which cotton goods undergo in the process of dyeing or printing, that of immersing them in a bath made of cow-dung and warm water.

DUODECIMALS, or CROSS MULTIPLICATION. A method of calculating the superficial or solid contents of such surfaces or solids as have a measurement in feet, inches, and twelfths of an inch.

DUODECIMO. The size of a book when the sheets are folded into twelve leaves.

DUPLICATE. The double of any thing; a duplicate *ratio* is the square of a ratio.

DUPLICATION OF THE CUBE, is the finding of the side of a cube, which shall be double of a given cube.

DUTCH GOLD. An alloy of copper and zinc, of no certain proportion, but containing more of the former metal than exists in brass.

DWARF WALLS. Walls of less height than the story of a building; the term is mostly applied to garden walls, with or without an iron railing at top; floors, and the sides of barns, granaries, &c. are often supported upon dwarf walls.

DYEING. The art of dyeing consists of fixing upon cloths of various kinds, silks,

wood, marble, &c. any color that may be required, in such a manner as that they shall not be easily altered by those agents to which the cloth will most probably be exposed.

DYER'S FUMING LIQUOR. The protochloride of tin, obtained by boiling 1 part of tin with 2 of hydrochloric acid; the clear solution which remains, when cold, contains the salt. It is used very much by dyers to change the color of numerous metallic dyes, and to precipitate various vegetable extracts. It is the *sal jovic* of old authors.

DYNAMICS. That part of the science of mechanics which explains the laws of bodies in motion.

DYNAMOMETER. Instruments for measuring the relative strength of men and animals; and occasionally, the power of machinery. The following cut represents a very simple dynamometer, adapted to this latter purpose:—

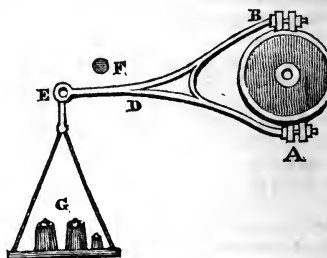

A E B is a lever made of iron or steel, having two spreading branches D A, D B, and capable of being fixed on the circumference of a pulley, by means of the pinching screws A and B. The lever would, therefore, revolve with the shaft C, were it not prevented by the stud or pin F. A scale is suspended from E, and according to the weights requisite to be placed in the scale G, before they will pull down the lever, will, of course, indicate the power of the machinery.



The second vowel, and fifth letter of the English alphabet. It has many sounds; a short sound, in *bet*; long, in *revere*: like *a*, in *clerk*; like *u*, in *voter*: besides being frequently silent, as in *some*, *time*, &c. and joined to the consonants *g* and *k*, renders them soft. It

also varies its sound in other languages, both ancient and modern. E, standing alone, signifies *east*. On medals, and ancient coins,

it stands for the name of any city, the name of which begins with this letter.

EARTH. The name of the world which we inhabit. It is a planet situated at the distance of 95 millions of miles from the sun, round which it revolves at the rate of 17 miles each second of time, completing its whole revolution in an elliptical orbit, in 365 days, 5 hours, 48 minutes, 57 seconds, while it turns on its axis once in 24 hours; that axis being inclined to the axis of the ecliptic at the angle of 23° and a half. Its form is that of a sphere slightly compressed at the poles. Its mean diameter, 7,916 miles, and its cir-

cumference, 25,000. It is attended with 1 satellite, *the moon*. The earth's surface contains nearly 197 millions of square miles, of which, scarcely one-third is dry land, and not one-tenth part inhabited by man. The population of the whole earth is between 800 and 1,000 millions of human beings. The interior is supposed by some persons, to be hollow; by others, a molten mass of metal, or a body of fire; others think it filled with water. Man has never penetrated a mile deep beneath the surface.

EARTHENWARE. Articles made of burnt or vitrified earth.

EARTHQUAKE. A shaking of certain parts of the earth's surface, produced by causes not perceivable by our senses. Three causes have been assigned for earthquakes. First, electricity, or the sudden passage of a large quantity of the electric fluid through a certain portion of the earth. Secondly, the formation and sudden irruption of steam within cavities under the crust of the earth. Thirdly, the ignition of pyrites, detonation of gases, or other violent chemical actions.

EARTHS. A class of chemical bodies, which are tasteless, inodorous, dry, not inflammable, but little soluble in water; not readily to be fused, and of a moderate specific gravity. They constitute the greater part of the soils, gravel, and stones which form the crust of our globe. Their number is ten; *silex, alumina, magnesia, lime, barytes, strontian, zircon, glucine, yttria, and thorina*, (see these names.) The four first have been long known, the remainder have been discovered within these few years. The earths are all more or less alkaline, uniting and forming salts with the acids. They were formerly considered simple substances; they are now known to be composed of oxygen, united to peculiar bases, and seen to form a connecting link between the metals and the alkalis.

EARTH TABLE, GROUND TABLE. That course of stones in a building which is even with the ground.

EARTH-WORK. A term applied to cuttings, embankments, and all other works where earth is to be removed or collected together. (See *Embankment*.)

EASEL. A frame used to support a picture while it is being painted. Easels are of various forms and sizes, according to the size of the picture, and the habits of the painter.

EAST. One of the principal or cardinal points of the horizon, or of the compass. It is that exact point in which the sun rises at the time of the equinoxes.

EAU. A French word, signifying water, &c. used in English with other words, for several spirituous waters, particularly perfumes, as *eau de Cologne*.

EAU DE COLOGNE. A celebrated odori-

ferous liquor, for the making of which there are numerous receipts. One is as follows:— Take of the essences of bergamot, lemon-peel, lavender, and orange flower, each 1 ounce. Essence of cinnamon, half an ounce. Spirit of rosemary, and of the spirituous water of melisse, each 15 ounces. Strong spirits of wine, $7\frac{1}{2}$ pints. Mix, let it stand a fortnight, and distil by a heat not greater than that of boiling water.

EAVES. Parts of the roof projecting beyond the walls of a building.

EAVES BOARD. EAVES CATCH. EAVES LATH. An arris fillet, nailed across the rafters at the eaves of a roof, to raise the tiling or slating in a small degree, that the wet may be less inclined to drip or run down the walls.

EBB. The retiring of the tide is called the ebb of the tide; and the water left in holes on the beach after the waves have retired is called ebb water.

EBONY. A hard, heavy, black, valuable wood, which admits of a fine gloss, the produce of the diosphyros ebenum. It is much used by the turner and carver for small ornaments, and by the mathematical instrument maker for the frames of quadrants, parallel rules, &c. for which, and similar purposes, it is admirably adapted, because it is but little liable to warp when exposed to the sun or air, and is little affected by moisture.

EBULLITION. The art of boiling up by heat. Fluids suffering ebullition are becoming, at the same time, converted into a vapor, in consequence of the heat they have imbibed, dilating and separating their particles.

ECCENTRIC. Any thing out of a usual or proper centre; properly speaking, two circles, one wholly or partly within the other, but which have different centres. The following shows various groups of eccentric circles:—

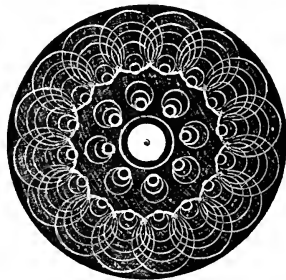

ECCENTRIC. A contrivance in mechanics, whereby variation in the direction and velocity of motion is effected. An eccentric of this description is usually employed in the steam engine to work the valves attached to the cylinder.

No. 2 is the main shaft of the fly-wheel; upon the end of this is placed a pulley or wheel eccentrically, A. As the shaft turns round, it draws the wheel into the position,

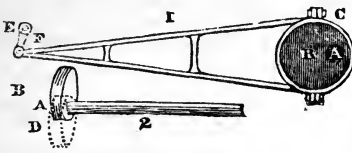

D. Now recurring to No. 1, A is the axis of the main shaft. B, the eccentric. C is a loose collar in which B slides. As this eccentric moves round, it draws C, and consequently, all which is attached to it, backwards and forwards; moving at the same time the end F, and with it, the arm of the cock or valve E.

ECCENTRIC CHUCK. A chuck of such a nature, that work which is attached to it in the lathe may be altered as to its centre of motion, so as to produce eccentric arcs and circles at the pleasure of the workman, when cut with the usual turning tools. By means of the eccentric chuck, the most beautiful combinations of circles may be formed. The illustration to *Eccentric* was turned by the means of this chuck.

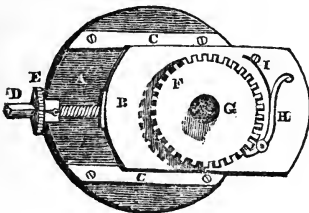

A is a round plate of metal, at the back of which, in the centre of it, is a screw which fits the mandril of the lathe. B is another plate of metal, which slides backwards and forwards over the surface of the other. It moves smoothly between the two cheeks C C, and is drawn more or less out of the centre of A by the screw D, near the end of which is the wheel E, which being graduated adapts the instrument to a nice adjustment. On the centre of B is a wheel of 96 teeth, F, capable of being moved around its centre G, and of being fixed at any place by the detent H, which is made steady by the spring I. The centre G is a prominent screw upon which the work is to be fixed.

ECCENTRIC CIRCLE. In astronomy, a circle described from the centre of the orbit of a planet, with half the greatest axis as a radius.

ECCENTRICITY. In the orbit of a planet is the difference between the centre and focus of the ellipse in which it revolves.

ECHINUS. That part of the egg and tongue moulding which surrounds the egg; sometimes also considered as synonymous with ovolo.

ECHO. The reverberation or reflection of sound.

ECLIPSE. An obscuration of either the sun or moon, arising from the peculiar position of the earth and moon at the time. For example, whenever it happens that the moon in its monthly course around the earth comes exactly between the earth and sun, the shadow cast behind the moon would fall upon a certain portion of the earth's surface, and the inhabitants at that part would see that a part of the sun's face or disc would be obscured by the interposition of the moon, and they would witness what is called a *solar* eclipse; and the number of digits seen to be eclipsed would be according to the position of the observer, whether in the centre or near the edge of the shadow. If exactly in the centre he would see the moon in the centre of the sun's disc, with a rim of light around her, which would be called an *annular* eclipse. Those parts of the world not within the shadow would not be affected. A *lunar* eclipse is when the earth is between the sun and moon; and as the earth is so much larger than the moon, its shadow is large enough to cover her whole face; and when situated exactly between the centres of the sun and moon, a *total* eclipse of the moon takes place; if not centrally situated, it is only a *partial* eclipse.

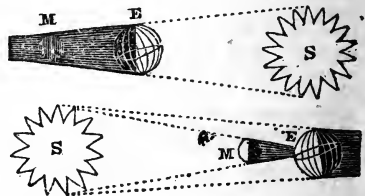

ECCENTRIC PUMP, consists of a hollow drum or cylinder of metal, D D; in the interior of which, a solid cylinder B, of the same length, but of less diameter, is made to revolve in water-tight axes. The inner cylinder being placed so much out of the centre of D D, that in its revolution, one side of it touches the side of B. The surface of the inner cylinder is also furnished with four circular flaps, C C C C. Two rods of metal slide through B, so as to open the valves on one side, when the opposite valves close by pressing against the case of D D. The water is supplied from the well, through A; it is then scooped up by the opening

valve, and conveyed by that valve to the top, where, as the valve closes, the water is squeezed up into the pipe E.

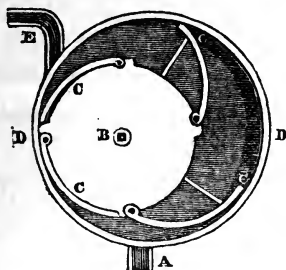

ECKHARDT'S CAPSTAN. A capstan which acts upon the same principle as the Chinese crane; (See *Crane*.) It is shown in the following cut, and will be recognized as of very frequent use in rope-grounds. It has an advantage over the common capstan, as the ratchet wheel and catch are unnecessary.

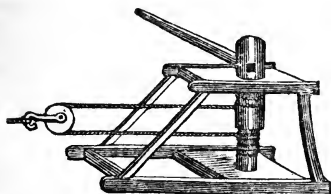

ECLIPTIC. A great circle in the heavens, in which the sun appears to move; but correctly speaking, it is that path among the stars in which the orbit of the earth is situated. It is in the centre of the zodiac; is inclined to the earth's axis at an angle of $23^{\circ} 28'$ which is called the obliquity of the ecliptic: as depicted on an artificial terrestrial globe, it crosses the equator at two opposite points, that is, at the beginning of Aries, and of Libra. It has marked upon it the signs of the zodiac, with the degrees of each.

EDGE. A narrow angle, made by the union of two planes or surfaces; also, the narrow side of a very thin rectangular prism; thus, we say the edge of a tabular crystal, the edge of a door, of a board, &c.

EDGE, Railway. A certain description of roadway, in which the carriages run upon rails, or the edges of rails, as in ordinary railroads; the term being used in distinction to such roads as are made of flat blocks or trams. In the latter case, the carriages can run in any direction; but when between rails, they are confined to a certain course. The friction also of rails is much less, and they are not so liable to be covered with stones and other impediments.

EDGE TOOLS. Such as cut by chipping or shaving away, as the axe, chisel, plane, &c.

EDUCTION PIPE. In steam engines, that pipe in which the expended steam escapes; in pumps it is that pipe by which the water raised is led away, or in which it is forced up.

EDULCORATE. A cleansing of any thing by means of copious washing with water, and subsequent filtering.

EFFECT. That which is produced by an operating cause. In works of art it is used to indicate the appearance that is produced, or is the result of their execution; or the sensation with which it affects the spectator. In mechanics, the measure of the real power of any machine, after deducting that portion which is lost or expended in overcoming the inertia and friction of the moving parts, and every other source of loss.

EFFECTION, denotes the geometrical construction of a proposition. It is also used in reference to problems, which, when they are deducible from, or founded upon some general propositions are called the *geometrical effections* of them.

EFFICIENT CAUSE. That which produces an effect.

EFFICIENT. In arithmetic, the same as factor. (See *Factor*.)

EFFLUVIUM. A subtle vapour, which escapes from most substances, and which is perceived only by the scent it yields.

EFFERVESCENCE. The commotion produced in fluids by some parts of the mass suddenly taking the elastic form, and escaping in numerous bubbles.

EFFIGY. EFFIGIES. In painting, resemblance, image, representation, or portrait of a person.

EFFLORESCENCE. A term applied in chemistry to the crystals of certain salts, which, on exposure to the air, part with a portion of their water, and crumble down into a white powder.

EFFLUENT. Flowing from; running out.

EFFLUX. A flowing out.

EFFORT. The force with which a body in motion tends to produce an effect, whether the effect be really produced or impeded by any obstacle which intervenes.

EGG and TONGUE, or BALL and ARROW ORNAMENT, consists of oval and arrow-shaped bodies, placed in juxta-position along a moulding. It is one of the boldest, most elegant, and common decorations of classical buildings. No other shows so strong a contrast between its members, or gives so fine an effect of light and shade. It is slightly varied to suit the style which it embellishes, whether Grecian, Roman, or Elizabethan.



EGG CEMENT. Mix the white of eggs with quick lime powdered, to the consistency of a thin paste, and apply it to broken china, glass, &c. the pieces of which it will unite with considerable strength.

EGG STAND. An electrical apparatus for the convenience of supporting eggs or oranges, when a shock is to be passed through them, whereby they are rendered beautifully luminous. The foot stand supports two uprights, joined by a bar at top, through which a wire terminated by a ball passes. The eggs are supported upon three little stages, which slide up and down between the uprights. The lower one resting on a piece of metal. When to be used, place the eggs so that they touch each other, and slide down the upper wire till it bears upon the upper egg; then pass the shock of a Leyden jar through them.

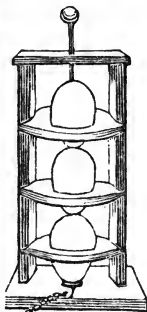

EGG VARNISH. (See *Glaire*.)

ELAÏDIC ACID. When elaidine has potass added to it, it yields a peculiar fatty acid, called the elaidic acid.

ELAÏDINE. A solid substance, formed by shaking olive oil, mixed with 3 per cent. of nitrous, and 9 of nitric acid; after resting an hour it becomes concrete, or is converted into elaidine.

ELAÏODIC ACID. A peculiar acid, obtained from castor oil.

ELAINE. The thin oil contained in tallow and other fats, oils, &c. It may be procured as follows:— Press tallow between some pieces of blotting paper, the elaine will soak into it; then by taking away the rest of the tallow, and soaking the paper in warm water, the elaine will float upon the surface, from which it may be collected, by skimming it off, or by means of a dropping tube.

ELASTICITY. The property which numerous bodies have of yielding to a certain force, and afterwards of recovering their original shape.

ELASTIC BITUMEN, or MINERAL CAOUTCHOUC. A peculiar mineral, found only near Castleton, in Derbyshire, and at Montrelais, in France.

ELASTIC CURVE. The curve formed by any elastic body, when fixed by one end, the rest of the body projecting horizontally, till the other end is loaded with a weight, when it would be bent into an elastic curve.

ELASTIC FLUIDS, are those which are possessed of an elastic property, as air, steam, &c.

ELASTIC GUM. Indian rubber, or caoutchouc.

ELATIN. The active principle of elaterium, or squirting cucumber.

ELBOW. An abrupt turn in a river, or in a piece of wood or iron-work; often thus made to strengthen adjoining surfaces, the elbow-iron, &c. being screwed to each.

ELBOWS OF A WINDOW. The two flanks of panelled-work, one under each internal shutter.

ELECTIVE AFFINITY. The apparent preference which chemical substances show to certain others when combining with them; for example, sulphuric acid will unite with most of the metals, but will leave any of the rest to unite itself to barytes: it is therefore said to have an elective affinity, that is, a stronger affinity for that than any other metal.

ELECTREPETER. An instrument for readily changing the direction of electrical currents. (See *Clarke, Bird, &c.*)

ELECTRIC. All bodies are so called when they show electrical appearances upon being rubbed; or which will not permit the electric fluid to pass along them.

ELECTRICAL, or ELECTRIC. Belonging to electricity.

ELECTRICAL AMALGAM. (See *Amalgam*.)

ELECTRICAL APPARATUS, consists of all the machinery used to illustrate the science of electricity; (for a particular description of each instrument, see its substantive name, as *Dance, Condenser, Discharger, Leyden Jar, Magic Picture, Thunder House, &c.*)

ELECTRIC ATTRACTION and REPULSION. One of the visible effects of a disturbance of the electric fluid. When two bodies are excited or electrified in a similar manner, they repel each other; if excited so that one shall be in a different electrical state to the other, they will be attracted. Suspend two feathers on dry silken threads, and hold to them an excited glass tube, they will be attracted to it at first, being in a different state; but afterwards they will be repelled from it, and from each other, because they are then from imbibing the fluid from the glass, both electrified similarly.

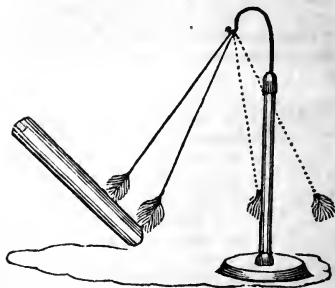

ELECTRICAL CEMENT, for joining together the various parts of an electrical apparatus.

Melt together 5 ounces of resin, 1 of bees-wax, and 1 of red ochre. This may be employed in cementing the plates of metal in the galvanic troughs.

ELECTRICAL CHARGE. The greatest quantity of the electric fluid which any body can be made to contain; or the greatest degree of disturbance which can be given to its inherent fluid. The restoration of that fluid to a state of quiescence, is called the discharge or shock.

ELECTRICAL CIRCUIT. Any series of wires, or other conductors, intervening between the inside and outside of a charged Leyden phial, whereby the jar is discharged. Every thing which is to receive a shock must form a part of this circuit; and connecting the outside and inside of such a jar or battery, is called completing the circuit.

ELECTRICAL CONFIGURATIONS. The peculiar radiating forms taken by certain powders when sifted upon charged electrics. They may be made as follows:—Put a sheet of dry glass on a piece of tin-foil spread on a table, and draw over the surface of it, in any fanciful device, the knob of a small charged Leyden jar; then, having ready tied up in a piece of loose muslin, a mixture of equal parts of sulphur and red lead, in powder, sift them on the plate of glass, when it will be seen that the mixed powder will separate; and while the sulphur of it settles in a close line on the exact tract of the knob, the red lead will arrange itself at a little distance on each side, in the most beautiful star-like ramifications. The following gives but a faint idea of the effect:—

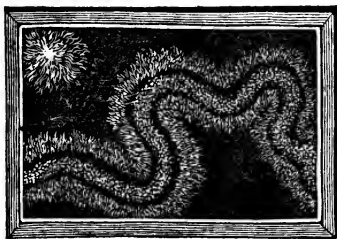

ELECTRICAL CONDUCTORS. (See *Conductors* and *Lightning*.)

ELECTRICAL CURRENTS. The passage of the fluids from one place or object to another, through conducting substances: as for example, from the different sides of a charged jar; from one end of a galvanic battery to the other; along conducting wires, &c.; or when a current passes through a wire, which has another wire so near to it as to be affected by the passage of the fluid, the fluid which actually passes along the wire is called the

primary current; and that effect or disturbance which takes place in the approximate wire, is called the *secondary* current.

ELECTRICAL EXCITATION. The power of disturbing the electric fluids, so that it becomes apparent either to our senses, or by the well-known effects which it produces. Bodies thus influenced are said to be excited.

ELECTRICAL FLUID. That particular and universal power, substance, or property which pervades all nature, occasioning, when disturbed, those appearances and effects, known in science as electrical and galvanic; besides numerous natural phenomena, such as lightning, the aurora borealis, and perhaps the whole of chemical and magnetic action. Some philosophers maintain that all these effects are produced by different states of the same electric fluid; (see *Franklin*.) Others, believe that two electric fluids exist; one of them always disturbed when the other is, and each acting in opposition to the other at all times. (See *Du Fay*.)

ELECTRICAL INDUCTION. The power possessed by an excited body in influencing other bodies in the vicinity of it, without touching them.

ELECTRICITY. A science which explains the laws which govern the excitation, distribution, and other phenomena of a peculiar element, called the electric fluid. Electricity, in its more limited acceptation, explains the electric effects produced upon various bodies by friction or pressure only. In its general meaning, it includes also, the explanation of those departments of science, called galvanism, electro-magnetism, and thermo-electricity. That effect, resulting from friction alone, constituting a branch only of a general subject, and which, for distinction sake, is called *common*, *free*, or *frictional* electricity.

ELECTRICITY, Disguised, is when the electric fluid is accumulated upon the surface of a body, and yet which has but little tendency to fly off, in consequence of that body being under the influence of another electrified body, which is near to it and insulated. The lower plate of the electrophorus is an example of disguised electricity.

ELECTRICITY, States of. When the electric fluid in any body is so disturbed as to become apparent, one part of that body has the fluid in a redundant state; in the other part, it is deficient, or contains less than the quantity natural to it. The former, is called *accumulated* or *positive* electricity; and the latter, *negative*. Upon the supposition of two fluids, the former, is the *vitrious*; the latter, the *resinous* fluid. Free or common electricity is popularly divided into *atmospheric*, *animal*, *chemical*, *mechanical*, and *medical*, according to its effects, and the particular phenomena it explains.

ELECTRIC LIGHT, *Brush, Star, Spark.* The spark or stream of brightness seen when a considerable quantity of the electric fluid passes through any imperfect conductor. If it pass into the air from a point electrified positively, it resembles a *brush*, as B. If from a negative point, a *star*, A. If it pass in a considerable quantity, and with rapidity, from one conductor to another, through the air, it will put on the appearance of a spark, more or less zigzag, C, and be attended by a snapping noise.



ELECTRICAL MACHINE. Any instrument adapted to collect a considerable quantity of the electric fluid, as produced by friction. The principal electrical machines now in use are of two forms; in one, a *cylinder* of glass is to be excited; in the other, a *plate* of glass, (see *Cylinder and Plate.*) In either case, there are one or more cushions which rub against the glass; and a prime conductor, (see *Conductor,*) to collect and retain the electric fluid given off by the glass.

ELECTRICAL NON-CONDUCTORS. (See *Electrics.*)

ELECTRIC POLES, OR ELECTRODES. The two opposite ends of a charged electric or galvanic apparatus. When the word pole is used, we distinguish them by the terms *positive* and *negative*; but employing the term electrodes, the positive, is called the anode or platinode; the negative, the cathode or zincode.

ELECTRIC SHOCK. The rapid passage of a quantity of the electric fluid through any substance, which occasioning a disruption of some bodies, and a convulsion to others, renders the term appropriate.

ELECTRO-CHEMICAL ACTION. The chemical changes that take place owing to the interference or agency of an electric current.

ELECTRO-CHEMICAL EQUIVALENTS, are the same, and coincide with the ordinary chemical equivalents.

ELECTRO-CHEMISTRY. That division of electricity, which treats of the chemical effects produced by the passage of an electric current through a chemical compound.

ELECTRODES. The poles of a galvanic battery. That pole in which the electric fluid enters, is called the negative pole, or electrode.

ELECTRO-DYNAMIC CYLINDER. (See *Ampere.*)

ELECTRO-DYNAMICS. That division of the science of electro-magnetism, which explains

the laws of all rotations, vibrations, and other motions occasioned by the mutual action of the magnetic and electric fluids.

ELECTRO-GASOMETER. A small apparatus for collecting and measuring the amount of gas, resulting from the decomposition of water by electricity. (See *Bachhoffner, Clarke, &c.*)

ELECTROLYTES. All substances susceptible of direct decomposition by a passage of the electric fluid through them, as water.

ELECTROLYTIC ACTION, OR ELECTROLYSIS. Galvanic action considered in reference to chemical decomposition.

ELECTRO-MAGNET. A bar of iron which assumes temporary magnetic properties, in consequence of a current of electricity being made to pass through it. It is made by twisting around the bar of iron, whether straight or shaped like a horse-shoe, a wire covered with silk or cotton, or other non-conducting material, and passing a current from one pole of a galvanic battery to the other, along the coil of wire. The circulation of the fluid through the wire, will render the bar of iron within it a temporary but powerful magnet, capable of sustaining a considerable weight. It loses this power the moment the connection with the battery is broken. In the cut, A is the electro-magnet. B and C, the weight raised. N and P, the wires from the poles of the battery.

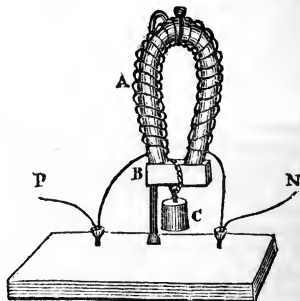

ELECTRO-MAGNETIC APPARATUS. (See *Ampere, Callan, Bachhoffner, Clarke, Barlow, Sturgeon, Faraday, Marsh, &c.*)

ELECTRO-MAGNETIC COIL. (See *Callan.*)

ELECTRO-MAGNETIC COIL MACHINE. (See *Coil.*)

ELECTRO-MAGNETIC HELIX. (See *Helix.*)

ELECTRO-MAGNETIC MACHINE, OR ENGINE. A machine by which the effects of electro-magnetism may be noticed or ascertained.

ELECTRO-MAGNETIC MULTIPLIER. The original name of the galvanometer, an instrument for measuring the intensity of an electric current. The original instrument

was merely a mariner's compass, with a covered wire coiled five or six times round it. When an electric current is made to pass along the wire, the compass-needle is driven out of its usual polar direction, the north end being turned east or west, according to the direction of the current. The following is another, but not a more powerful form of the instrument:—

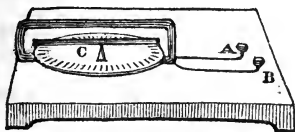

A B are mercury cups, to hold the wires from the poles of the battery. C the magnetic needle, with a graduated card beneath it, and the coil of wire around it.

ELECTROMOTIVE FORCE. Volta supposed that when two metals were in contact, a certain force was in operation, tending to effect a transfer of electricity from the one metal to the other. To this force he gave the name of electromotive.

ELECTRO-MAGNETIC SPHERE. (See *Barlow and Sturgeon.*)

ELECTRO-MAGNETISM. The science which explains the action of the electric fluid and the magnet upon each other.

ELECTROMETER. An instrument to measure the quantity and quality of the electric fluid disturbed during any experiment or process. Some electrometers act upon the principle of electrical attraction or repulsion, certain parts of them becoming divergent in proportion to the intensity of the disturbance of the fluid within them, such as Coulomb's electrometer, the quadrant electrometer, &c. Others depend for their action upon the circumstance that the electric fluid acquires momentum in proportion to its concentration, as in the balance electrometer, the medical electrometer, &c. (See *Balance, Coulomb, Lane, Medical, &c.*)

ELECTRO-MICROMETER. Any instrument adapted to measure very minute quantities of electricity; synonymous with condenser.

ELECTRO-MOMENTUM. The power exerted by an electric current when suddenly turned out of its direct course; or, when made to pass from a good conductor to one which is less perfect.

ELECTROMOTIVE. The power of motion conferred upon magnets, &c. by electrical action.

ELECTRON, OR ELECTRUM. The former is the Greek—the latter, the Latin name for amber, which being rubbed, shows the property of attracting light substances; from which word and circumstance we derive the word electricity. Glass, and also gold, or an

alloy like gold was, by the ancients, called likewise electrum.

ELECTRO-NEGATIVE AND ELECTRO-POSITIVE. Those bodies which, when subjected to the action of a galvanic current, are apparently attracted to the anode, or positive pole of the battery, are called electro-positive, or cathions. Those attracted to the cathode, are electro-negative, or anions; they being supposed to be in a contrary electrical state to the pole to which they are attracted.

ELECTROPHORUS. A simple instrument, which, when once excited, retains its electrical energy, which it is ready to give out continually for a long period. It consists of two plates; the lower one may be a plate of tin, ten or twelve inches in diameter, with the edges turned up, so as to hold the following composition when poured hot into it, forming a cake, when cold, of about one-eighth, or from that to a quarter of an inch thick. The composition is, pitch 1 part; asphaltum 4 parts; and bees'-wax 1 part; or pitch, rosin, and bees'-wax in the above proportions. The upper plate may be of wood, covered completely with tin-foil, and having a glass handle to lift it by. It is two or three inches less in diameter than the lower stand. When to be used, the instrument is to be warmed, the resinous plate rubbed with a piece of warm flannel, and the upper plate put upon it, its glass handle being previously dried. Lifting up the upper plate by the handle, the edge of it will give a spark; touch the upper plate with the finger, and put it down again on the other; upon lifting it a second time, it will give another spark, and so on for a considerable period. The upper plate has often a wire with two pith balls attached to it.

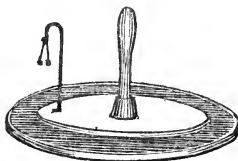

ELECTRO-PULSATIONS. Electric currents or shocks, which pass in such rapid succession between the two sides of a charged Leyden jar, or between the poles of a galvanic battery, that the shocks are not to be individually distinguished.

ELECTROSCOPE. Any instrument to indicate the disturbance of the electric fluids; but not of sufficient accuracy to show the precise amount of that disturbance, such as Bennett's gold-leaf electroscope and Sausseur's pith ball ditto.

ELECTROTYPE. A method of taking reverse fac-similes of medals, coins, copper-

plates, seals, &c. by means of the power which voltaic electricity has of decomposing metallic salts. A piece of zinc is soldered at one end of a wire, and the medal, seal, &c. (if a seal, or other non-metallic body, it must be previously covered with black-lead,) at the other end, and then the medal immersed in a saturated solution of copper, and the zinc end in acidulated water, there being some membrane or other porous substance between the two solutions. This being altogether a galvanic circle, decomposition of the sulphate of copper will take place, and metallic copper be deposited on the medal; after some hours the deposit will be thick enough to remove, and will be found an exact reverse impression of the medal. The following cut shows three forms of apparatus:—

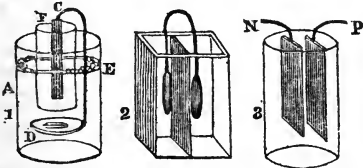

In No. 1, A is a jelly pot. B a porous tube within it. C is the wire, with a bar of zinc inside the tube B, and the lower end bent, holding the medal D upon it. E is a shelf surrounding the tube B, to hold crystals of sulphate of copper. No. 2 is a square wooden box, with a division of plaster of Paris across it. No. 3 is a glass jar, holding a copper-plate to be copied, and also another copper-plate; when these are connected with the poles of a galvanic battery, one of the copper-plates will be dissolved and deposited on the other.

ELEMENTS. The name assigned to those simple substances, of which, by combination, all bodies are supposed to be formed; or in other words, elements are those bodies which have never yet been decomposed, and which, are therefore, supposed to be simple bodies. They are all the metals, supposing the earths to have metallic bases, azote, bromine, carbon, chlorine, fluorine, hydrogen, iodine, oxygen, phosphorus, and sulphur.

ELEMENTS. In geometry, denote indefinitely small portions of curves, surfaces, and solids.

ELEMI. A resin which exudes from the amyris elemifera, a tree of South America. It is yellow, comes in small lumps, is strongly aromatic, and of a spicy taste. It is used by the varnish maker, and in making lacquer.

ELEMINE. The crystalline and purified resin of elemi.

ELEVATION. The altitude or height of any thing. The elevation of the equator, in astronomy, is an arc of the meridian, less than

a quadrant, intercepted between the equator and the horizon of the place. The elevation of the pole, or of a star, is the distance between the pole or the star, and the horizon.

ELEVATION. The front of a structure; also a geometrical drawing of it, no regard being had to perspective.

ELGIN MARBLES. A series of ancient sculptured marbles, named after Thomas, Earl of Elgin, by whom they were purchased and brought to this country, and deposited in the British Museum. They are parts of the celebrated Temple of Minerva, called the Parthenon, and of other buildings, situated on the Acropolis, at Athens.

ELIMINATION. In algebra, any operation by means of which all the unknown quantities, except one, are exterminated out of an equation, whence the value of that one becomes determined, and hence by substitution the value of all the rest.

ELIQUATION. An operation by which one substance is separated from another that is less fusible. It consists in the application of a degree of heat, sufficient to fuse the former, but not the latter.

ELIXIR. A tincture extracted from many ingredients, whereas a simple tincture is extracted from only one.

ELIXIR, Universal. An object endeavoured to be discovered by the alchemists was to find an universal elixir or a medicine that would cure all diseases.

ELLAGIC ACID. A substance produced along with gallic acid, by the exposure of moistened galls to air. It is insoluble in boiling water; therefore the gallic acid may be washed away from a solution of galls, and the ellagic acid remain.

ELLIPSE, ELLIPSIS, or OVAL. In geometry, a conic section formed by cutting a cone entirely through the curved surface, not parallel to the base; so that the ellipsis, like the circle, is a curve that returns into itself, and completely incloses a space.

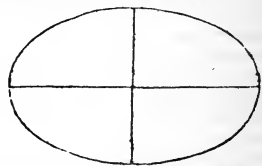

ELLIPSOID. A solid formed by revolving an ellipsis on its axis; if revolving on its longest axis, it would be an *oblong* ellipsoid; if on its shortest, an *oblate*.

ELLIPSOGRAPH. (See *Trammel*.)

ELM. A tough, pliable kind of wood, the produce of the *ulmus campestris* tree, and other species of the same family, indigenous to England. It is hard, does not easily split with the driving of nails and spikes; is very perishable when placed partly in and partly

out of the ground; but is very durable if kept dry. It is used for mill-work, Windsor chairs, coffins, water-pipes, and axletrees. When stained, it much resembles mahogany.

ELONGATION. A lengthening. In astronomy, it is the angle under which we see a planet from the sun; that is, the angle formed by two lines drawn from the earth to the sun, and to the planet. In the following cut, the angle formed by the dotted lines on the one side of the sun, A B, B C, show an angle of $28^{\circ} 20'$, which is the greatest elongation of the planet Mercury; and the lower lines, C B, D B, mark $47^{\circ} 48'$, or the greatest elongation of Venus:—

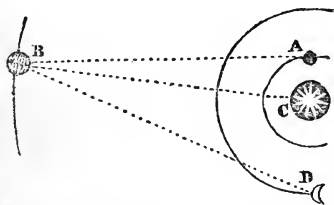

ELYDORIC PAINTING. A method of painting in a vehicle composed of oil and water, whereby the solidity of oil painting, and the freshness and transparency of water colors are combined. The process may be described as painting in oil colors (using only poppy oil,) under water, drying the painting afterwards by a gentle heat, water being left for some time previously floating upon it. This style has been used only for very small pictures, such as miniatures.

EMBALMING. A process by which animal bodies are preserved, by means of impregnating them with resinous and balsamic substances.

EMBANKMENT. A continued mound of earth, thrown up to defend low lands from the encroachments of the sea, for the forming of roads over valleys, the raising of terraces, confining the stream of a canal, &c.

EMBATTLLED. Provided with battlements.

EMBELLISHMENT. Decorations; something added to another ornament, yet of such a nature that it may be removed without injury, and therefore distinguishable from ornament. Thus panelling to a wainscot is an ornament to it, but a mirror hung against it an embellishment. The mouldings in a building are ornaments; the statues are embellishments.

EMBOLUS. In mechanics, any thing inserted and acting in another, as the sucker of a pump, the piston of a steam engine, &c.

EMBOSSING. The art of forming work in relief, whether it be cast, moulded, or cut with tools. According as it is raised little or much above the general surface, it is said to be in *low*, *mean*, or *high* relief.

EMBOSSSED. Adorned with bosses or raised figures.

EMBRASURE. One of the openings of a battlement, through which archers may shoot or cannons be pointed. (See *Battlement*.) Also long narrow openings in a wall, splayed inwards, for the same purpose.

EMBROIDERY. The enriching of cloth, stuff, or muslin, by figures worked thereon with a needle, with thread of gold, silver, silk, or cotton.

EMERALD. A green precious stone. It is composed of silice, alumine, and carbonate of lime; and its color is produced by chromium. Emeralds are now chiefly procured from Peru.

EMERGENT YEAR. The first year of any particular era.

EMERSION. In astronomy, is the re-appearance of the sun, moon, or planet, after having been eclipsed. It is also used sometimes to denote the re-appearance of a star, which has been hid by the sun's rays. Emersion, in physics, denotes the rising of a solid body above the surface of a fluid in which it floats.

EMERY. A hard mineral, of a dark grey color. The best is obtained from the island of Naxos, in the Mediterranean. The extreme hardness of this substance has caused it to be employed in various arts, such as polishing precious stones, grinding glass, for brightening and cleaning iron utensils, and generally as a grinding and polishing powder.

EMETINE. The peculiar principle of ipecacuhana root.

EMINENTIAL EQUATION. A term used by some authors for a certain assumed equation, which involves in itself several particular equations.

EMPYREAL AIR. A name given by Scheele to oxygen.

EMPYREUMA. A term implying a peculiar odour, derived from the overheating of matters under the process of distillation, or when otherwise scorched.

EMULSION. A principle very similar to, but not identical with albumen, possessed by all seeds which form an emulsion with water, such as almonds.

ENAMEL. The art of painting with colors on gold or copper, &c. which being burnt are changed into a kind of glass. The most familiar examples of enamel painting is the white surface and black figures on watch and clock faces or dials.

ENAMELLED CARDS. Cards which are covered on one side with a coating of white lead and size, and when dry passed between highly polished steel rollers to give them the requisite gloss.

ENAMELS. Colors or compounds, which when heated to a certain degree become changed into a kind of glass of a certain

color, according to the ingredients contained in the compound. The enamel which is the simplest, and combines with all others, is an oxyde made by calcining together about 30 parts of tin to 100 of lead—this is called *calcine*. To every 4 parts of this, add 4 parts sand, and 1 of sea salt, and melt them together—this should be perfectly white. A *blue* color is given by a very little oxyde of cobalt; a *yellow* by the sulphate of silver, or with more certainty by equal parts of white lead and white oxyde of antimony, fused with sal ammoniac; a *green* by the deutoxyde of copper, or still better by the oxyde of chrome; *red* by the protoxyde of copper; *black* by the protoxyde of iron; and *violet* by the peroxyde of manganese.

ENCARPI. Synonymous with festoons.

ENCAUSTIC PAINTING. A manner of painting which is executed by means of fire. It is an art, practised by the ancients, the method not being now understood. It appears to have been executed by pencils made of wax colored, which were laid on the picture by keeping the wax pencils warm by the aid of a fire close to the artist's hand; the blending of the colors being afterwards accomplished by similar means.

ENCHASED. Ornamented with figures, scroll-work, &c. in low relief; such ornaments being carved with a tool, and not cast.

ENDECA ON. (See *Undecagon*.)

ENDLESS CHAIN, ROPE, &c. One of which the two ends are joined together, forming a loop or hoop; as we see in the lathe band, the spinning-wheel, and in very numerous machines, where a rotatory motion is continued from one wheel or axis to another at a distance.

ENGAGED COLUMNS. Such as are partly united in, and partly detached from walls and piers.

ENGINE. The name given to all machines for producing and applying any power to a particular purpose. Engines take their names either from the power which puts them in action, as a steam engine, a water engine; or else from the purpose to which they are applied, as a pile engine, a pumping engine, &c.

ENGISCOPE. A reflecting microscope.

ENGLISH BOND. (See *Bond*.)

ENGLISH OAK. That particular species of oak timber which is indigenous to English; it is the wood of the *quercus robur*, and is much harder, tougher, and more durable than that of any other species.

ENGRAVING. The art of depicting, by incisions in any matter or substance, but particularly on plates of metal, blocks of wood, hard stones, &c. for the purpose of producing certain impressions from them, called prints. The art of engraving is divided into various branches or classes; as engraving on hard

stones for rings, seals, &c. called *seal engraving*, or *gem sculpture*; engraving dies, for coins and medals, called *die sinking*. On copper and steel plates, which according to the particular style practised, is called *line engraving*, *etching*, *mezzotinto engraving*, or *scraping*, *aquatint*, *stipple*, *etching on stone and glass*, *wood engraving*, &c. (See these words for each process.)

ENGRAVER'S CUSHION, is used to support the plate or block of wood, upon which any engraving is being executed. Cushions are of various sizes, from 3 inches to 12 in circumference, and are made of a thin leather case, like the covering of a cricket ball. This is filled with damp sand; the orifice which has admitted the sand then sewed up, and the whole put in a press. The flat surface now assumes it will long retain.

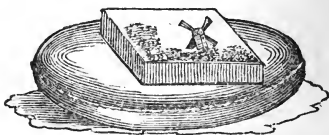

ENGRAVER'S GLOBE, is a globe of glass, about 6 or 8 inches in diameter, which when in use is to be filled with clear water. It thus becomes a powerful lens, and will collect and concentrate the light of a candle or lamp upon any work which may be in hand, as may be seen in the following illustration. The first surface of the globe rendering the rays parallel; the second converging them to a focus. These globes are usually made with a foot to them, though not necessarily so.

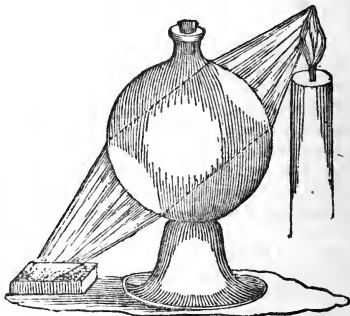

ENROCKMENT. A mass of large rocks or stones piled up into a solid rough wall, to resist the force of water beating against it.

ENTABLATURE. The whole of a story of a building which is above the columns, including the architrave, the freize, and the cornice.

ENNEAGON. A figure of nine sides and angles.



ENTASIS. A swelling in the middle of a column or baluster.

EOLIPILE. (See *Æolipile*.)

EPACT. The difference in length between solar and lunar time; if reckoned in months, it is called the *menstrual* epact; if reckoned in years, the *annual* epact. For example, a calendar month is 31, 30, or in February 28 or 29 days. Suppose January 31 days, and that there is a new moon on the first of the month. As a lunar month is 29 days, 12 hours, 44', 3", the monthly epact, or the age of the moon at the end of the month would be 1 day, 11 hours, 15', 57". As the civil year is 365 days, 6 hours, nearly, and the lunar year 354 days, 8 hours, 48', 38", the annual epact will be nearly 11 days.

EPICYCLOID. A curve generated by a point in one circle, which revolves about another circle, either on the concavity or convexity of its circumference. If around the outer part of the circumference, it is called an exterior epicycloid; if around the concavity, it is an interior epicycloid.

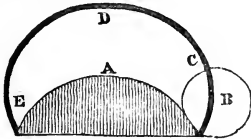

A is a circle, around the circumference of which B revolves. A point on the circumference of B bears a pencil, and as B revolves, the pencil forms the curved line CDE, which is the epicycloid. In the next cut are shown a series or system of external

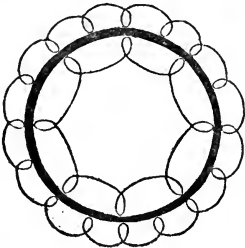

and internal epicycloids made around and within the same circle.

EPICYCLOIDAL WHEEL. A very beautiful method of converting circular into alternate motion, or alternate into circular, as shown in the annexed cut. The large wheel, which is toothed on the inner side, is firmly fixed to a frame-work. The smaller wheel is of exactly half the diameter of the other, and revolves about its centre. While this revolution of the smaller wheel is taking place, any point whatever on its circumference will describe a straight line, or will pass and re-pass through a diameter of the circle once during each revolution; and thus a piston rod, or other reciprocating part, may be attached to any point on the circumference of the smaller wheel.

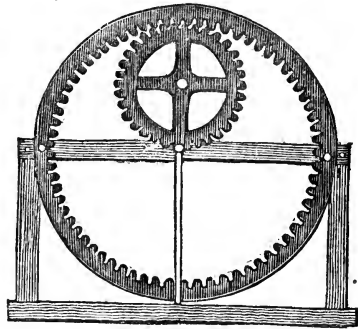

EPIGRAPH. An inscription or title, denoting the use or destination of the monument inscribed. Thus, the name of a building, if put upon it, is an epigraph.

EPISTYLUM. The architrave, or lowest of the three divisions of an entablature.

EPOCH. The beginning of a period when a new computation is begun. Thus, the great epochs of the world are its creation, the deluge, and the time of the founder of certain religions, or of great events. The birth of our Saviour, among the Christians; the flight of Mahomet, among the Turks and Arabs; the Olympic games, of the Greeks; the building of Rome, by the Romans, &c.

EPSOM SALTS. Sulphate of magnesia.

EQUABLE MOTION. A motion that is regular, steady, and uniform.

EQUAL. A term of relation between two or more things of the same magnitude, quantity, or quality.

EQUAL ALTITUDES. A correct method of calculating true time. Take the altitude of the sun at any time in the forenoon, and mark the time by a watch; then wait until the afternoon, when the sun is found to have the same altitude. Half the elapsed period will

be the exact noon, and the watch, if necessary, is to be corrected accordingly; for example, if at 10 minutes to 12 by watch, the sun on any day has 60° of altitude; and if found to have the same altitude at 12 minutes past 12, the watch will be too fast by 1 minute; because 10 added to 12, and the same divided by 2, gives 11, instead of 10 minutes before 12, consequently the watch is to be put back 1 minute, when the whole elapsed time would be equally divided.

EQUAL ANGLES. Such angles as will exactly cover over each other; no relation being had to the length of their sides, or to the distance which each may extend from the angular point.

EQUAL ARITHMETICAL RATIOS, are those wherein the difference of the two less terms is equal to the difference of the two greater.

EQUAL CURVATURES, are such as have equal radii of curvature.

EQUAL FIGURES, are those whose areas are equal, whether the figures be similar or not.

EQUAL GEOMETRICAL RATIOS, are those whose least terms are similar aliquot or aliquant parts of the greater.

EQUAL SOLIDS. Such as have the same capacity or solidity.

EQUALITY. In algebra, is a comparison of two quantities, which are in effect equal, though differently expressed or represented.

EQUATION. In algebra, is any expression in which two quantities, differently represented, are put equal to each other, by means of the sign = between them, as $cd + ab = 12$. These equations receive different names, according to the circumstances contained in them. For example, the above is a *simple* or *single* equation; when one of the parts contains a square number, it is a *quadratic* equation, as $a^2 \times ab = 12$; if a cube number, it constitutes a *cubic* equation, as $a^3 \times a^2 \times ab = 24$; while the following, which involves a fourth power, is *biquadratic*, $a^4 + a^3 + a^2 = x$. A *literal* equation contains letters only; a *numeral* equation has numbers attached to, or forming some of the quantities. An equation is called *binomial*, if of two terms only, as $x^3 = 16$. *Determinate*, if containing only one unknown quantity. *Indeterminate*, if of more than one unknown quantity. *Reciprocal* with the sum of each pair of terms equally distant from the centre one are equal, as $x^5 - x^4 - x^3$, &c.

EQUATION OF PAYMENTS. In arithmetic, is the finding the time to pay at once several debts, due at different times; so as to allow of a proper average of interest or discount for the whole.

EQUATION OF THE CENTRE, is the difference between the true and mean place of a planet, or the angles made between the true and mean place.

EQUATION OF TIME, denotes the difference between mean and apparent time, or the reduction of the apparently unequal time; or motion of the sun or a planet to equable or mean time, or motion.

EQUATOR. A great circle of the sphere, equally distant from the poles of the world. It is represented in the artificial terrestrial globe, by a line graduated from a first meridian into degrees, both eastward and westward; which degrees, and the lines that run through them to the poles, indicate the longitude, either east or west, from the first meridian; while the equator itself divides the earth into the northern and southern hemisphere. The distance from the equator northwards indicating north latitude of places, and southwards, south latitude. The equator is also called the *equinoctial* line, or simply the *line*.

EQUATORIAL. An astronomical instrument adapted to perform several useful practical purposes, independent of any particular observatory. Two of which problems are to find the meridian by one observation only; and to point to a star in full day-light though not in the meridian.

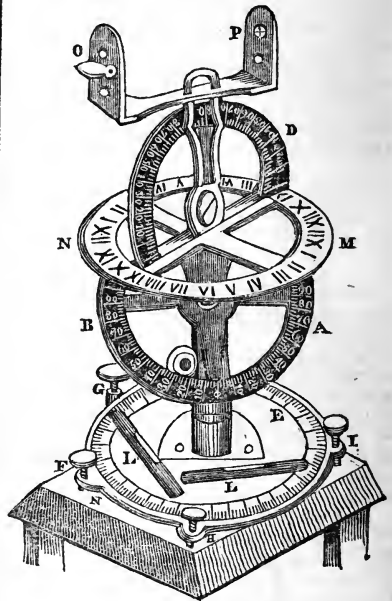

The instrument is attached to a strong stand, upon which it is kept perfectly erect by means of the tangent screws F G H I, assisted by the two spirit levels L L. The lower stage E, which represents the horizon, has a scale of degrees marked upon it; and

firmly fixed to the centre is the upright spindle, to support the rest of the instrument. The next circle A B is also in degrees, and perpendicular to the horizon below. The next circle M N turns upon its centre, horizontally, and also vertically, by being attached to the circle below, so that it may be adjusted to the latitude and longitude of the place. This circle is called the hour circle. The uppermost semi-circle D is attached perpendicularly upon M N. The sights O P crown the whole, and by their support sliding up and down on D may be directed to any angle of altitude.

EQUIANGULAR FIGURES. Those which have equal angles.

EQUICRURAL TRIANGLE. Isosceles Triangle.

EQUIDIFFERENT. In arithmetic, is when in a series of quantities there is the same difference between the first and second as between the second and third, third and fourth, &c.

EQUIDISTANT ORDINATES, are a series of lines drawn across an irregular figure, the area or solidity of which cannot be accurately measured, unless by dividing it into several parts. The lines of separation in this and other cases, if parallel to each other, and at like distances, are called equidistant ordinates.

EQUILATERAL. Having equal sides. Of such figures some have also equal angles; as an equilateral triangle, A; a square, B, &c.; others, though their sides may be equal, may vary as to their angles, as a rhombus, C.

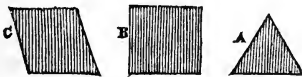

EQUILIBRIUM. A state of quietude, arising from any thing being equally balanced on different sides; as for example, scales equally weighted, an object balanced upon a point or edge, &c.; also, the term is applied when acted upon by two opposite and equal forces, which neutralize each other, as a boat rowed up a stream at the rate of four miles an hour, while it is carried in the opposite direction by the stream four miles an hour, would be at rest, or in a state of equilibrium.

EQUINOCTIAL COURE. That great circle which passes from the poles of the world through the equinoctial points.

EQUINOCTIAL DIAL, is one whose plane is parallel to the equator. The properties of this dial are that the hour lines are all equally distant from each other, quite round the circumference of a circle. The gnomon or style, is a straight pin or wire, set up in the middle of the circle, perpendicular to the plane of the dial, &c. The sun shines upon the upper

half of the dial-plate for half the year, and on the other half during the remainder of it.

EQUINOCTIAL LINE. A great circle in the heavens, under which the equator of the earth moves; therefore, for the sake of convenience, we consider them as identical. (See *Equator*.)

EQUINOCTIAL POINTS. The two points in which the equator and ecliptic cross each other, one being in the first point of Aries, the other in the first point of Libra; the sun is in the first of these points at the time of the vernal equinox, and in the latter point at the autumnal equinox.

EQUINOX. The time when the sun enters one of the equinoctial points. There are two equinoxes, the *vernal*, which takes place on the 21st of March, and the *autumnal*, which occurs on the 24th of September. At the time of the equinoxes, both day and night consist of twelve hours each—the sun rises and sets at exactly six o'clock: he rises exactly in the east, and sets exactly in the west. Also, at these periods, as well as at the solstices, true and apparent time exactly correspond.

EQUINOXES, Precession of. It is found by observation, that the equinoctial points, and all the other points of the ecliptic are continually moving backwards, or westward; this is called the precession of the equinoxes.

EQUISETIC ACID. A peculiar acid, said to reside in a genus of plants, called equisetum.

EQUIVALENTS, Chemical. An expression used by Dr. Wollaston to designate the primary proportions in which bodies unite; the numbers representing these proportions, being referred to one standard substance of general interest, such as oxygen or hydrogen being considered as one. Equivalent, therefore, is but another term for atomic weight.

EQUIVALENTS, Scale of Chemical. A table in which the atomic weights of all the simple and numerous compound bodies are arranged, so that we may see at once the atomic weight of any substance, and thereby infer its composition; and also in what manner it will combine with others.

ERECT DIALS. Such as stand perpendicular to the horizon.

ERROR. In arithmetic, is used to denote the difference between the result of any operation obtained by trial, and the true result required by the question. The term is chiefly used in the rule called position.

ERROR. In astronomy, is the difference between the places of the heavenly bodies, as determined by calculation and observation.

ERYTHRIC ACID. A peculiar acid in erythrea centaurium.

ESCAPEMENT. The part of a clock or watch movement which receives the force of the spring or weight, to give motion to the pendulum or balance. Escapements are of

various kinds; that used in ordinary clocks is as follows, and will show the general construction:—

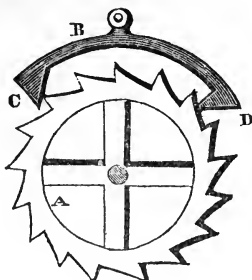

The wheel A, which from the peculiar shape of the teeth, and from its use, is called the escapement wheel, is supposed to be connected with the rest of the wheel-work of the clock, and moved round by the weight at the other end of the train. B is an arc, with a pallet at each end. The point of suspension of this is connected with the pendulum, and as this latter vibrates, the arc B vibrates also, liberating at each vibration one of the teeth of the wheel.

The next cut shows the escapement of the common watch. A B is called the fuscè, or scape (escapement) wheel, moved round by the main spring. C D are two pallets moving in and out between the teeth of A B. G is the balance wheel, which vibrates on the top of the watch:—

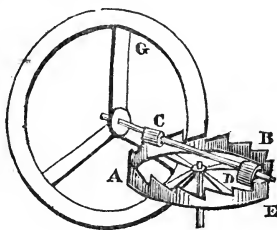

ESCLIC ACID. An acid peculiar to the horse chesnut.

ESCUTCHEON. A shield of armorial bearings.

ESSENCE. A thin, limpid, fragrant oil, or else a heavy essential oil, diluted with alcohol until it becomes limpid, still however retaining its full fragrance.

ESSENTIAL OILS. Such oils as are volatile, and generally obtained by the distillation of the herbs and seeds which afford them. They are fragrant, very inflammable, soluble in a very small degree in water, but in any proportion in spirits of wine. They evaporate

at a degree of heat a little above that of boiling water. They leave no oily stain on paper, and are decomposed with violent inflammation by the addition of nitric or sulphuric acid. The following three kinds may be obtained by expression:—Lemon, orange, and bergamot.

ESTIVAL. Belonging to summer

ESTUARY. An arm of the sea.

ETCHING. A species of engraving in which the copper or other plate is not cut by a tool, but eaten away by aquafortis poured upon it. The process is as follows:—Procure a clean copper or steel plate; warm it, rub a little etching ground upon it—spread this smoothly over the plate by dabbing it, while still hot, with a ball, made of a piece of silk, tied round some cotton wadding. Then hold the plate, with the covered side downwards, over a smoky flame, until it appears quite black. When cold, draw upon the surface of the ground with a needle, which will cut through the ground, and lay bare the copper beneath wherever the needle touches. Next surround the plate with an edging of *etching wax*, putty, or other similar material, and pour upon the plate some diluted aquafortis: after a few minutes, according to the strength of the acid, bubbles will arise from the bared lines; these being brushed off two or three times, the lines will be bit in sufficiently. The acid, therefore, may be poured off, and the plate cleaned with spirits of turpentine, when the design will be seen etched upon it.

ETCHING ON GLASS, is performed in nearly the same manner, except that as glass will not bear heat like metal, the etching ground must be put on like a varnish, and may consist of melted wax, or mastic varnish. The fluid used for biting-in is liquid fluoric acid, or else the vapor arising from a mixture of powdered Derbyshire spar and sulphuric acid, assisted by heat.

ETCHING ON STONE. A species of lithography, by which fine-lined etchings on metal are well imitated. It is performed thus:—The stone being prepared with a smooth, clean surface, as lithography, it is covered with a coat of gum water, blackened with lamp-black; when dry, the etching is made with a needle, which, scratching through the ground, lays the surface of the stone bare. Linseed oil is now washed over the whole; this adheres to the bare lines only, and the black gum ground being washed off as soon as the oil is dry, leaves that to receive the ink used in printing.

ETCHING GROUND. A varnish to cover or form a ground upon copper and other plates, previous to the etching needle tracing the design upon them. It may be made thus:—Melt together 2 ounces of white wax, 2 ounces of asphaltum, and half an ounce each of black pitch and Burgundy pitch; let the

whole boil ten or twelve minutes, then pour it into cold water and mould it up into balls with the hands.

ETCHING LIQUID. (See *Biting-In.*)

ETCHING NEEDLE. Any fine pointed, stout needle, used for scratching through an etching ground previous to biting-in.

ETHER. The name of a class of very light, volatile, inflammable, and fragrant spirituous liquids, obtained by distilling in a glass retort, a mixture of alcohol with almost any strong acid. According to the acid employed, so is the name, and in some degree the nature of the ether.

ETHER. ETHEREAL. Radiant or imponderable matter. (See *Aether.*)

ETHERINE. A combination of carbon and hydrogen, in the proportion of 2 volumes of carbon vapor to 4 of hydrogen, to form one volume of etherine.

ETHERIFICATION. The process by which an acid and alcohol are so united together as to form ether.

ETHERO-SULPHURIC ACID. (See *Ethionic Acid.*)

ETHIONIC ACID. An oleaginous liquid, formed when the vapor of anhydrous sulphuric acid is slowly introduced into pure alcohol, kept at a low temperature.

ETHIOPS. An old name given to numerous black metallic preparations.

ETHIOP'S MINERAL. The black sulphuret of mercury.

ETHYL, or ETHYLE. The supposed compound inflammable basis of ether.

EVAPORATION. The process by which any body is converted into and carried off in vapor. Many substances evaporate naturally, such as camphor, ice, water, &c. Others require the application of artificial heat, as mercury.

EVECTION. The most considerable of the moon's irregularities, occasioned by the action of the sun upon the moon.

EVEN NUMBER. That which may be divided by 2, without a remainder.

EVENLY-EVEN NUMBER. That which may be divided by 4, without a remainder.

EVOLVENT, or EVOLVENT. (See *Involute.*)

EVOLUTE. The curve formed by the unwinding of a string which has been coiled around another curve. For example, let A B C be a certain curve with a string coiled

from A to D. Unwind this, still keeping it tight, and with a pencil attached to the end, describe the course this end of the string will take during the unwinding, and the curve thus formed will be the evolute. Thus, D E F G will be the evolute of A B C.

EUCHLORINE. Protoxyde of chlorine.

EUDIOMETER. An instrument adapted to the examination of the gases, atmospheric air, &c. It is of two forms; in one, it consists merely of a graduated tube, in which the air to be examined is placed, and a glass bottle (as in Dr. Hope's,) attached to it, E. In Dr. Henry's, an Indian rubber bottle is substituted for that of glass, as at D. The other form of the instrument supposes that the gases are to be inflamed by the electric spark; they therefore are furnished with two wires nearly meeting each other, within the tube. A is such an one as used by Volta. B is that of Sir H. Davy; and C the contrivance of Dr. Ure.

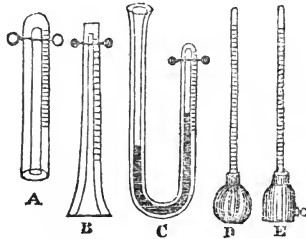

EUUDIOMETRY. The art of analyzing the respirable properties of any air, by ascertaining the quantity of oxygen contained in it; or generally, the analysis and purification of gases comes under the term eudiometry.

EUPHORBIVM. A gum resin, exuding from a large shrub of the East Indies, called euphorbia officinalis.

EUPION. A tasteless, colorless, inflammable, inodorous, greasy, limpid liquid, obtained from animal tar; or that produced by the distillation of horn, bones, &c.

EUSTYLE. Buildings are in eustyle when the space between the columns is $2\frac{1}{2}$ diameters, which Vitruvius maintained to be the best distance.

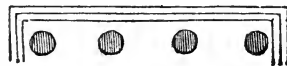

EXCAVATION. The art of hollowing or digging a cavity, either for the foundation of a building, the course of a canal, &c.

EXCHANGE. In arithmetic, is the finding how much money of one country is equal to a certain sum in another.

EXCHANGE, Arbitration of, is a rule in arithmetic which determines the method of

A A

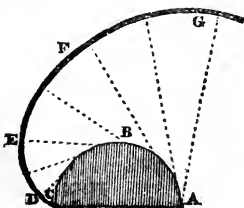

remitting money to, or drawing from other countries, in such a manner as shall be advantageous to the merchant.

EXCURSION. In astronomy. (See *Elongation*.)

EXGESIS. An ancient term for finding the roots of an equation.

EXHAUSTED RECEIVER. The receiver of an air pump when the air has been withdrawn from it by the action of the pump.

EXHAUSTING SYRINGE. The same as a condensing syringe would be with its valves reversed, or like one of the barrels of an air pump.

EXPANSION. That degree of increase of which bodies are susceptible when acted upon by heat, the imbibing of moisture, &c. When bodies expand, their specific gravity decreases in proportion to the expansion of them, except in the case of their imbibing moisture, when the quantity of moisture which fills the pores must of course be allowed for, that being an adjunct, and forming no part of the body itself. The instruments by which expansion is measured are called thermometers, pyrometers, hygrometers, &c.

EXPANSIVE ENGINE. A steam engine in which the supply of steam is cut off, previous to the stroke being complete; the rest of the power necessary being supplied by the expansive power of the steam already admitted. In high pressure engines the whole force is derived from the expansion of the steam.

EXPERIMENT. A trial or practical proof of any thing. Experiments are said to be mechanical, chemical, electrical, magnetic, &c. according to the subject to which they more immediately belong.

EXPERIMENTAL PHILOSOPHY. A general exposition of all those sciences which can be illustrated by experiment. Such are chemistry, hydrostatics, hydraulics, pneumatics, acoustics, optics, electricity in its numerous forms, astronomy, heat, &c. forming altogether one department of *natural philosophy*; the other department being *natural history*. (See *Science*.)

EXPLORATOR. A contrivance invented by Beccaria, consisting of a wire, whose insulated ends, provided with knobs of tin, are fastened to a pole over the chimney, or to the top of a tree. From this wire, another leads into a chamber, through a glass tube covered with sealing-wax, communicating in the chamber with an electrometer, by which the electricity of the air may be daily observed.

EXPLOSION. The breaking up, scattering, or destroying, by means of sudden and powerful chemical detonations; or in some cases, by undue mechanical pressure. Thus, we speak of the explosion of a stone by gun-

powder, the explosion of a boiler by an over-pressure of steam, &c.

EXPONENT. The small number or character attached to any quantity in arithmetic or algebra, showing that the power of it is changed. Thus 2, 3, 4, are the exponents of a^2 , a^3 , a^4 , &c.

EXPONENT OF A LOGARITHM. The index which stands before the logarithmic numbers, as in 1.6321784, the 1 is the exponent or index.

EXTENSION. In philosophy, one of the general and essential properties of matter; the extension of a body being the quantity of space which the body occupies, the extremities of which limit or circumscribe that body. It is otherwise called the magnitude, size, or bulk of that body. The extension of a body is measured in three different ways, in length, breadth, and in thickness. Extension may be *finite* or calculable, or *infinite*. Thus, the atmosphere is supposed to extend upwards to about forty-five miles; but the extension of the universe is infinite.

EXTERMINATION. A term employed by algebraists, to denote the taking away or cancelling of any of the terms of an equation, still retaining the same value of the whole.

EXTERNAL. EXTERIOR. Terms of relation, expressive of whatever is on the surface or outside of a body, and opposed to internal or interior.

EXTERNAL ANGLE. (See *Angle*.)

EXTRA CONSTELLARY STARS. Such stars as have not been classed under any of the constellations.

EXTRACTION OF ROOTS, is the finding of the square, cube, and other roots of a number or quantity, whether arithmetical or algebraic.

EXTRACTS. Products obtained by soaking or boiling vegetable substances in such a menstruum as will dissolve a certain portion of them, which portion is called the extractive principle. This is sometimes soluble in several menstrua, sometimes only in one or two. From the nature of the menstruum used, the extract is either *aqueous*, *oily*, or *spirituous*. Spirituous extracts are often called essences. Extracts are generally thicker, and contain, proportionably, a much greater quantity of vegetable extract than infusions or decoctions.

EXTRADOS. The exterior curve of an arch.

EYE. In architecture, a name applied to several circular parts and apertures, particularly the central circle of the Ionic volute; the circular or oval window in a pediment; a small sky-light in a roof; and an aperture in the summit of a cupola. The term, *bull's eye*, is also used in a similar manner, particularly when applied to the holes in the deck of a ship, to admit light to the cabin.



The sixth English letter : it is of rather uncertain sound, passing readily into *v*, *h*, *b*, and *p*. It is a semi-vowel, and one which has what the Germans call a *blowing* sound. It may be produced by putting the upper teeth against the lower lip, and trying to hiss. This aspiration may be more or less powerful. The character is said to have been introduced by the Eolians, who represented the sound by two Γ (gammas) placed one above the other. The Romans often used the F, inverted, instead of V; with them it indicated the number of 40, and with a dash over it, 40,000. In engravings, or pictures, stands for *fecit*, (made.) On medals, it stands for *Felius*, *Felix*, *Fabius*, *Favustus*, &c. F, with merchants, signifies *folio*, or *fiat*. It also is the name of the fourth note in music.

FABRIC. The structure or construction of any thing, particularly of a building.

FACADE. The general face or front which any considerable building presents towards a street, court, or garden.

FACE. The curved part of a cogged wheel which gives the impulse to another wheel.

FACE GUARD. A mask to defend the face and eyes from accident, in various chemical and manufacturing processes. It is usually a frame made to fit the face, and formed of wire-gauze.

FACE OF A STONE. The surface intended for the front of the work.

FACTS. In jewellery and crystallography, the flat surfaces which bound the angles of crystals, or into which a precious stone is cut; for example, a diamond cut so as to have numerous faces, is called *facetted*; but if ground with a uniform globular surface, it is called *rose* cut.

FACIA, or FASCIA. Any flat surface in a building; as for example, the plain flat part over a shop front, upon which the trade or name of the owner is painted. The bands into which the architrave of classical buildings is sometimes divided, are called so many fascia.

FACING. A small thickness of a better material placed over any thing, either to improve its appearance or to add to its strength; the brick or stone-work on the sides of a canal, a rampart, &c. is a facing; the fine plaster and stucco on walls; the panelling, and other smoothed wood-work on rough timbers, and other similar coarse substances.

FACTORS, or MULTIPLIERS. In arithmetic, are the multiplicand and multiplier, or those numbers, by the multiplication of which, another number is produced: thus, 5 and 8 are factors of 40, because the *factum* or product of them is 40; so also a and *y* are the factors of *ay*.

FACTUM. The result or product of multiplying two or more factors together, as 35 is the factum or product of 5 and 7.

FACULÆ. A name given by some astronomers to such spots of the sun's surface as are brighter than the rest, as *maculæ* denote those spots which are less bright.

FAGGOT. Bars of iron bound together for re-manufacture; also a bundle of sticks for fuel.

FAHRENHEIT'S THERMOMETER, is that arrangement of the scale of the instrument, in which the space between the freezing and the boiling points of water, under a medium pressure of the atmosphere, is divided into 180 parts or degrees; the freezing being marked 32°, and the boiling, 212°. This scale was adopted by Fahrenheit, because he supposed, erroneously, that 32 of those divisions, below the freezing point of water, which was therefore nought (0) on his scale, was the zero, or greatest degree of cold.

FAINTS. The impure spirit which comes over last, during the process of distillation. It being loaded with the impurities of all which the still at first held, it is very fetid and disagreeable.

FAIRY RING. A phenomenon frequent in the fields, formerly supposed to be traced by the fairies in their dances. There are two kinds; one of about seven yards in diameter, containing a round bare path, a foot broad, with green grass in the middle of it. The other is of different sizes, encompassed with a circumference of grass, greener and fresher than that in the middle. Some attribute them to lightning; others to a kind of fungus which breaks and pulverizes the soil.

FAKE. One of the circles or coils of a rope when coiled up.

FALCATED. Scymitar-shaped; a term applied to the appearance of the moon, when in the first and last quarter, or as it is commonly called *horned*.

FALLING SLUICES. Such as are so contrived as to fall down of themselves, and enlarge the water-way, on the increase of a flood in a mill-dam or river.

FALLING STAR. (See *Meteor* and *Aërolite*.)

FALLING STAR TUBE. An electrical experiment to imitate a falling star. It is a tube of glass four or five feet long, and of half an inch internal diameter, similar to that described under the word *Aurora*, but with a small ball inside at both ends. When this is exhausted of air, and a shock passed down it, it will represent with much effect the stream of light of the meteor.

FALSE, Rule of. (See *Position*.)

FALSE ROOF. The part between the upper ceiling and the true roof, called in ordinary circumstances a cock-loft, or garret.

FAN. Any flat, light contrivance, intended to catch the wind, and thereby to occasion a

current, either to produce coolness, to increase the draught of a fire, or to turn a machine into a certain required direction, as in the small vertical wheel mostly seen attached to the top of a windmill.

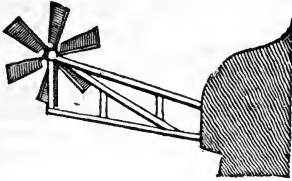

FANNERS. Vanes or flat discs revolving round a centre, so as to produce a current of air; generally used instead of a bellows for forges. (See *Blowing Machine*.)

FAN-SHAPED WINDOW. A window, consisting of part of a circle, the frame of which is cut into round notches. Such windows are common in early English buildings.

FAN TRACERY. A beautiful style of vaulting, in which the ribs spread out like a fan from certain points at the sides of a building. It was used in the Tudor buildings. Fine examples are seen in Henry the Seventh's Chapel, Westminster; King's College Chapel, Cambridge; &c.

FARADAY'S CRUCIBLE FURNACE, is thus described:—Procure a black-lead crucible or blue pot, about 12 inches high and 7 wide; then bore three rows of holes in it, as represented, five or six in each row, the holes being about $1\frac{1}{2}$ inches in diameter in the bottom row, and 1 inch in the upper two. Next bind it round with stout iron or copper wire, leaving a handle at each side, and cutting a groove with a file around the pot to confine the upper circle of wire, that it may not slip down. A small, round, moveable grate of plate iron, of a size to rest between the middle and bottom row of holes, is all that is now requisite. This being put in its place, a fire may be lighted. The lower holes will supply the necessary draught of air, and the vessel to be heated may be placed above.

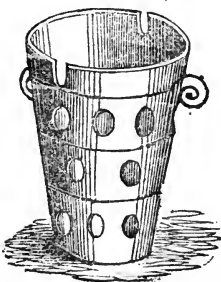

FARADAY'S ELECTRO-MAGNETIC DECOMPOSING APPARATUS, is seen below; it is merely a wooden box, with a partition formed of a piece of bladder, or brown paper, put across it; or else of four slips of plate glass cemented into a wooden foot, with the same partition, the whole being tightly bound together with string. Both sides of this apparatus are to be filled with the liquid to be decomposed, and the opposite poles of a galvanic battery being placed in the cells, decomposition readily takes place.

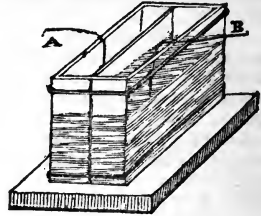

FARADAY'S ELECTRO-ROTATIVE APPARATUS, is of two kinds; both are represented in fig. 1, and may be used together, or each as a separate apparatus. A is a cup of quicksilver, containing a magnet, capable of motion, on a joint at the bottom of the cup, the wire D dipping into the mercury in A. The wire C is capable of motion around the joint at top. B is a second cup filled with mercury, for the end C to touch. It contains a magnet fixed in the centre. When a current of electricity passes from F, up the magnet and mercury, along D and C, and again through the mercury to the magnet in B, it finally makes its exit by E. In this passage, the magnet will turn round the wire in the cup A, and the wire C revolve about the fixed magnet in B.

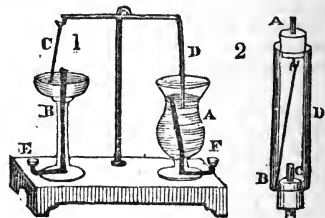
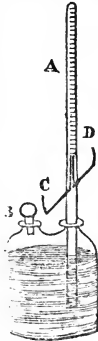

Fig. 2 exhibits another form of the rotating wire. D is a glass tube with a cork at each end; through the lower cork is inserted the pole of a magnet; through the upper is a wire, terminating in a ring, upon which is suspended, within the tube, a moveable wire B. A little mercury is poured into the tube, and a current of electricity passed from one end to the other, when the suspended wire will immediately rotate around the pole of the magnet C.

FARADAY'S LAMP FURNACE, is represented in the margin; it is recommended by Professor Faraday as extremely powerful and convenient. The lower part is a common tin box, the lid of which lifts off for the convenience of trimming the lamp. The cover is pierced with one round hole, in which to pour the oil, and four or five long holes, with a raised rim to each, for as many flat wicks. A wire is soldered to the lid also, and bent so as to support a copper tube, which, by being hung close over the light, increases considerably the draught of air, and consequently the intensity of the flame.*



FARADAY'S VOLTAMETER. Two instruments of this kind were invented by Professor Faraday; one is shown in the margin. It is made of a common glass bottle with two necks. One of them, B, is for filling and emptying the apparatus; the other neck has a glass tube inserted into it, which tube is closed at the top, and graduated; the lower end dips beneath the surface of the acidulated water in the bottle. The tube A has two platina wires, D, C, inserted in opposite sides, and bent up, withinside the tube. When the wires are made to convey the electric current, the water within the tube A is decomposed.



The second instrument is yet more simple. A is a heavy wooden foot. B is a tapering tube, bent so that the end E may dip under the shelf of the pneumatic trough, that the gas may be collected. C and D are the two wires, as before. The current is passed in the same manner.

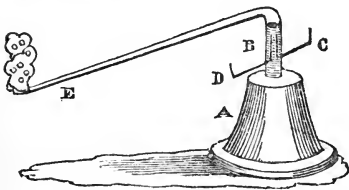

FARINA. The flower of any kind of corn, or starchy root, as the potato, arrow-root, &c.

FASCIA. (See *Facia*.)

FASCIAE. Belts; as those of Jupiter.

FASTIGIUM. The same as pediment.

FAT. Animal oil, in a concrete state. Fat is also a measure of capacity, differing in

different commodities. Thus, a fat of isinglass is 3 or 4 cwt. A fat of wire, from 20 to 25 cwt. A fat of yarn, 220 bundles. Fat is also a term used by printers, to designate such work as contains much white, and which they can get over quickly.

FATA MORGANA. (See *Mirage*.)

FATHOM. A measure of six feet.

FATTY ACIDS. (See *Acid*.)

FATUUS. (See *Ignis*.)

FAULTS. In mining, are disturbances of the strata, which interrupt the miner's operations, and put him at *fault*, to discover where the vein of ore, or bed of coal has been thrown by the convulsions of nature. The following cut shows a fault in a coal mine, in which it will be observed that the seam of coal is considerably higher on the one side than on the other:—

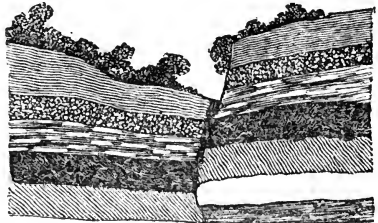

FEATHERED SHOT COPPER. If melted copper be poured in drops into hot water, the drops will harden of a round form, called *shot copper*; but if a constant supply of cold water is kept running in, the drops will be ragged, when they are said to be *feathered*.

FEATHER-EDGED BOARDS. Such as are thicker at one edge than the other.

FEATHERINGS. FOLIATIONS. CUSPS, or FOILS. Small arcs in the tracery of Gothic windows, &c. (See *Foil*.)

FEATHERS. A general name for the covering of birds. In building, feathers are any narrow slips of timber, to strengthen framing, partitioning, &c.

FEEDER. A cut or channel, by which a stream or supply of water is brought into a canal; sometimes the stream of water itself is called the feeder.

FEED PIPE. A part of the apparatus of a steam engine boiler, for keeping up a regular supply of water, as follows:—

Suppose A to be an open pipe, connected with a cistern of water above it. The water would flow through A; thence to B, by the side of C, and finally through the pipe D into the boiler. When the boiler has a sufficiency, the stone E floats, and the rod connected with it, and which passes through a stuffing box F, acts upon G, and lets down the valve H, whereby the passage of the water is stopped. When more is wanted, the float sinks, and again opens the valve at B, when

of course the water from the cistern flows again. The damper apparatus is always con-

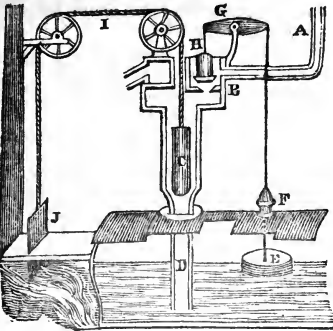

nected with the feed pipe. It acts thus:—When the formation of steam is too rapid, it presses upon the surface of the water in the boiler, and drives part of it up the pipe D, so as to lift the weight C, and this by means of the chain I, lets down the damper J, and thus the draught is decreased.

FEED PIPE OF A PUMP, is that which extends from the well of water to the valves or working barrel.

FELLING. The cutting of trees close by the root for the purpose of building.

FELLOES. The curved pieces of wood forming the rim of a carriage, cart, or other wooden wheel.

FELLOWSHIP. A rule in arithmetic, whereby partnership or joint accounts are regulated; also for the just division of prize-money, land, &c.

FELTING. The process by which hair, wool, or silk, is worked into a fabric of firm texture, called felt, without spinning or weaving; it is chiefly employed in the manufacture of hats.

FEMALE SCREW. The spiral threaded cavity in which a screw works.

FENDER, or FENDER PILES. The timbers placed in the front of a quay, wall, or other work, to defend it from injuries by vessels, &c.

FERETORY. A shrine, tomb, or relic box.

FERGUSON'S PYROMETER. A simple and popular instrument, to show the extension of metallic bars by heat. It will be readily understood from the following cut:—

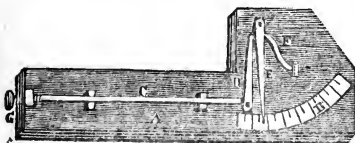

A is a solid piece of wood, which may be fastened upright on any convenient foot. B is a scale of degrees. C is a bar of iron to be heated. When this is in its place, it presses upon the arm D, near its pivot. D acts in a similar way upon the arm E, the point of which traverses along the scale, being kept steady by the spring F. To use the instrument, put the bar, before heating it, into its place, and turn the screw G one way or the other, until the point of E is directed to zero, on the scale; then take the bar out, without altering G, heat it, and put it back again, when its extension will be shown by the altered position of E.

FERMENT, Yeast, or Balm. The substance which when added in a small quantity to vegetable or animal fluids, tends to excite fermentation.

FERMENTATION. The changes which dead animal, or vegetable matters spontaneously undergo when subjected to warmth and moisture, all arise from fermentation; and according to the result and product of those internal changes, so the kind of fermentation is indicated. If gluten, sugar, and water be mixed in certain proportions, and assisted by a proper degree of heat, they will pass into the *vinous* fermentation, and a spirituous liquor be the result. If gluten unduly abounds, or the heat be too strong, or the process too long continued, it passes into the *acetous* fermentation, becomes sour, and vinegar is formed. Many things enter at once and very rapidly into the acetous fermentation. The heat exhibited by hay-stacks and similar collections of vegetable matter, is produced by the *bituminous* fermentation; so also is the formation of peat, and probably coal. Grain, when malted, becomes sweet, because of the *saccharine* fermentation. Bread is rendered light and spongy by the *panary* fermentation; and finally, all matter whatever, finally decays. If, as in the case of animal flesh, it becomes putrescent, it is because it has passed into the *putrefactive* fermentation.

FERRETTO. A substance used in coloring glass; obtained by the calcination of copper and powdered brimstone, or of copper and white vitriol.

FERRO-CYANATES, or more properly, **FERRO-CYANIDES.** Compounds of the ferrocyanic acid and various bases.

FERRO-CYANIC ACID. An acid of peculiar properties, formed of the cyanic acid and iron, which, although apparently a neutral salt, yet will unite with the usual bases, and form with that a class of double cyanides, which are quite distinct in character from the simple cyanides, formed by the action of the cyanic acid.

FERRO-CYANURETS. The same as ferrocyanates.

FERRO-CYANOGEN. A combination of cyanogen and iron, forming a proto-cyanuret of iron.

FERRO-PRUSSIATES. Another name for ferro-cyanic acid.

FERRO-PRUSSIC ACID. (See *Ferro-Cyanic Acid*.)

FERRUGINOUS BODIES. Those which contain iron.

FERRURETTED CHYAZIC ACID. (See *Ferro-Cyanic Acid*.)

FESTOON. A garland of flowers, or folds of drapery, when suspended so as to form elliptic curves with the ends depending downwards.

FIBRE. A thread-like substance, mostly of a vegetable origin, such as hemp, cotton, flax, coir, &c. Wool and silk have been called fibres, though very improperly.

FIBRIN. A peculiar organic compound, found both in animals and vegetables. It may be procured by beating fresh blood with twigs. Fibrin soon attaches itself to each stem, under the form of long reddish filaments, which become white by washing them. It is solid, white, insipid, without smell, insoluble in water, softens in the air, becomes viscid, brown, and transparent.

FICTILE. Vases, figures, &c. formed of clay.

FIELD BOOK. In surveying, a book used for setting down angles, distances, and remarks, as they arise in field practice, and from which the map of the estate is constructed, and the contents computed.

FIGURE. In arithmetic, is any one of the numeral characters in present use, commonly called digits. Figure, in the arts of painting, denotes a living creature generally; especially one that is human. In geometry, it is the general form or shape of a body. The figure of the moon is the general appearance of her disc, seen by the telescope.

FIGURE. In architecture and sculpture, is the representation of any thing in solid matter, such as statues, &c.; thus we say, figures of brass, marble, plaster, &c.

FILAMENT. A fine fibre or thread.

FILE. A well-known cutting instrument, having teeth on the surface, for cutting metal, ivory, wood, &c. When these teeth are made by cuts crossing each other all over the surface, then only are they properly called *files*. If the cuts on the surface are only in one direction they are *floats*; and if made of sharp points, at certain intervals from each other, they are called *raspers*. Files, according to the degree of fineness of the teeth, are called *rubbers*, *rough*, *bastard cut*, *second cut*, *smooth*, and *dead smooth*. Files are also distinguished by their shape, as well as by the purpose for which they are particularly designed.

FILLAGREE. A kind of ornamental work, in which flowers, &c. are formed of fine gold

and silver wire, curled or twisted in a serpentine form, and soldered together.

FILLET. A small square moulding which accompanies a larger moulding, as the upper and lower part of the following are fillets:—



FILTER. Any material or contrivance of such a nature, that a pure liquid may pass through it without the grosser impurities with which it may be contaminated passing at the same time: of such a nature are all porous stones, beds of gravel, sand, powdered charcoal, folded linen, or flannel, sponge, certain kinds of paper, &c.

FILTERING BAG. A conical shaped bag, made of close flannel, the seam being sewed up tightly. It is kept open at top by being tied to a hoop. It is used to filter the dregs of wine, vinegar, and similar liquids.

FILTERING CUP. A pneumatic apparatus, to show that if the pressure of the atmosphere be removed from an under surface, that the pressure still remaining on the surface above, has the effect of driving a fluid readily through the pores of such substance as it would not otherwise penetrate. A is a wooden cup. B is a plug or nozzle of oak wood fastened through the bottom of the cup, and projecting downwards two or three inches. C is a vessel put beneath it, when in use; and D the open-topped receiver of an air pump. To use the instrument, put a little mercury into A, and exhaust the air from D, when the mercury will soon filter through the oak, and fall into the cup C.

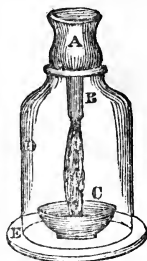

FILTERING FUNNEL. A glass or other funnel, made with slight flutes or channels down the lower parts of the sides. It is lined, when in use, with a piece of bibulous or filtering paper, folded, and loosely put in. The channels allow of the oozing of the liquid within more readily than a funnel of a smooth regular surface.

FILTERING MACHINE. Any contrivance by which liquids may be filtered, particularly water. The two following water filters will be found useful and easily constructed:—No. 1 shows how liquids may be filtered by upward pressure. Water is poured into the upper part of the vessel A. It runs down the pipe in the centre B into the lower compartment, C. The pressure of the water in A (enough being poured in that the whole should be full,) drives it through the perforated bottom, D,—the filtering material, (sand or powdered

charcoal,) E, and perforated division F; when, filling this chamber, it may be drawn off by G, while the impurities will remain in C, and may be let off by H.

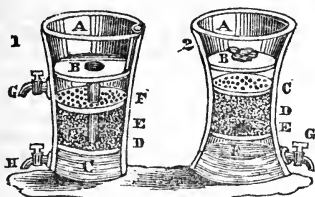

The second figure is a filter by the descent of the water through the purifying material. It is poured into A, passes through the hole partly stopped by sponge B, the perforated cover C, the sand D, and the second division E, into the vessel F, which is beneath, whence it may be drawn off by G.

FILTERING PAPER. Any paper which is sufficiently porous to suffer water to pass through its substance, such as the common blotting paper.

FILTERING STONE. A lump of oolite, or of sandstone, cut with a cup-shaped cavity to hold water, which the stone from its porous nature suffers to fall through in a series of drops; the impurities of it being left behind in the cavity.

FINIAL. A terminal ornament to a spire, pinnacle, canopy, &c.; most usually it consists of a mass of foliage.



FINITE. Limited either in time, power, or dimensions.

FINITOR, is sometimes used to denote the horizon.

FIR. A species of timber, much used in building. The native fir of this country is the *Scottish Fir*, which is chiefly employed in out-houses and for railings. It is much inferior to the Baltic timber, which is used wherever durability is required.

FIRE. That subtle, invisible cause, by which bodies are made hot to the touch, and

expanded or enlarged in bulk; by which fluids are rarefied into vapor; solid bodies become fluid, and are finally either dissipated and carried off in vapor, or otherwise melted into glass.

FIRES, Colored. Those beautiful and varied parts of fire-works, which present a peculiar and vivid color, different from that produced by the ignition of the gunpowder to which they owe their strength. They may be either in the state of flame, or a glowing fire. Colored flames are produced by setting light to spirits of wine, in which one or more of the following substances has been dissolved. For crimson, nitrate of strontian; blue, nitrate of barytes; a sickly yellow, common salt; a lemon color, raspings of amber; russet, crude antimony; bronze red, use Greek pitch; green is produced by verdigris; pale white, by camphor; strong silver white, by raspings of ivory. Sulphur damped with alcohol burns with a bright blue. For colored fires, see *Theatrical Fires*, and *Rocket Stars and Rains*.

FIRE ARMS. All those sorts of arms charged with powder and ball; as cannon, mortars, muskets, pistols, &c.

FIRE BALLS, are of three kinds; one natural—the other two artificial. The first are collections of ignited gases, which shoot like stars across the heavens; or else masses of metallic substances, which become incandescent by falling into our atmosphere; or else, as some suppose, are stones thrown from volcanoes in the moon. The second kind of fire balls are merely round lumps of baked clay, which are sometimes placed at the bottom of a stove, to increase the draught, and thereby promote the combustion of the fuel. The third kind is intended as a fuel by itself. It is usually a composition of various combustible substances so tempered together, and so united with various earthy matters, as to possess the requisite degree of combustibility, according to the purpose for which it is to be used. The principal object being to produce a fuel convenient in use, that shall be strong and durable, and made of materials otherwise of little value. Peat imbued with tar; the dust of coal, pitch, and clay; peat, and coal, and many other matters have been recommended. It is usually made in the shape of balls.

FIRE BRICK. A very hard kind of brick, made of a particular species of clay, which resists the strongest action of a fire, therefore used for the lining of furnaces, and other similar purposes.

FIRE DAMP. (See *Carburetted Hydrogen*.)

FIRE ENGINE. An engine for projecting water upon buildings on fire. There are several contrivances for this purpose. Those of modern construction are made upon the principle of the force pump. That used at

the present time in London is the invention of Mr. Simpkin, and is thus described :—

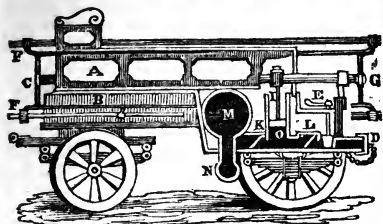

A is part of the side of the engine. B a pocket or square box, projecting from the side to hold the hose and other necessary implements. C G is the axis of the handles which work the engine. F F the handles themselves. D is the end of the pipe admitting the water from the plug to the working part of the engine. E a handle, to turn the cock beneath, inserted into the pipe D. I is one out of the two working barrels, with its piston withinside. L is the suction valve. K the delivery valve. M the air chamber. N a screw, upon which the delivery hose is fixed. A hose being screwed upon D, the other end of it lying in a well of water, and the cock E being open; upon working the engine, the water passes through the valve L into the chamber O. The contrary stroke shuts the valve L, and opens that at K. The water, therefore, is propelled into M; the elasticity of the air within which drives it with force through the hose connected with N.

FIRE ESCAPE. Any contrivance adapted for the rescue of persons from burning houses. Fire escapes are of three kinds. First, those which are kept by the inmates of the house, such as knotted ropes, that they may let each other, or themselves down. Second, fire ladders. Third, carriage escapes, or such as require a distinct vehicle for their conveyance, and which are mostly furnished with a cradle and tackling to let down the persons who may be in danger.

FIRE HOUSE, or ROSIN HOUSE. An electrical apparatus to show the inflammation of rosin by the electric shock; the house

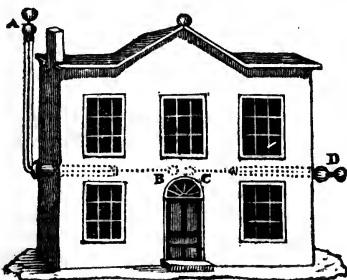

itself is of tin, and is the mere ornamental adjunct to the experiment.

A is a glass tube extending downwards, and passing through the side of the house. It contains a wire throughout its whole length, with a ball near A at one end, and a ball B at the other. C D is also a tube and wire similar to the other, but shorter, and straight; and the wire passing through two corks in the tube may be drawn out as required. When to be used, the two inner balls are to be covered loosely with tow dipped in powdered rosin, and an electrical shock of considerable intensity passed through the wires; if this be done cleverly, the rosin will be inflamed, and the house appear as if on fire.

FIRE-PLACE. A general term for the hearths and lower parts of the chimneys, stoves, &c. in which the fires are made to heat apartments.

FIRE PUMP. A force pump erected in a populous neighbourhood for the extinguishing of fires in the surrounding district. The annexed is the view of the fire pump erected at Aldgate, (London.) In some late experiments, this pump delivered a stream of water with considerable force at a distance of 1600 feet from the source of supply. The upper part of the cut is the pump, as viewed externally. Below is the working barrel, in which the piston and suction valve are contained; attached to which is the air vessel to keep up the constancy of the supply during the downward stroke of the handle, and to increase the force of projection of the water. The pipe on the upper part of the air vessel is continued within the pump case, and terminates by a union joint in the required length of hose. From the working barrel proceeds the feed pipe communicating to the well.

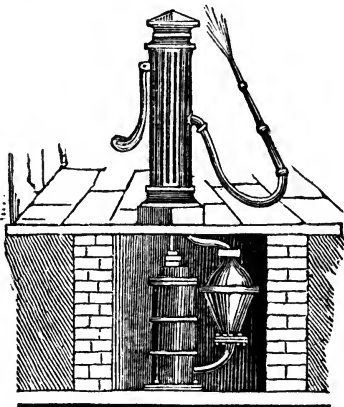

FIRE SHIP. A small vessel filled with combustible substances, and employed for

the destruction of an enemy's shipping, by being run into the midst of them, and set on fire by the crew before they quit the vessel.

FIRE-WORKS. Cases filled with various compositions of an inflammable nature, which when fired, burn with different circumstances of motion, size, brilliancy, color, &c.; the whole intended for the amusement of those who witness the firing, and used to celebrate particular events, or as a means of testifying joy and congratulation. The principal compositions of all fire-works consist of gun-powder, saltpetre, charcoal, and sulphur, mixed occasionally with other ingredients. The method of making the various kinds will be found under their respective names of *Bengal Light, Cracker, Rocket, &c.*

FIRMAMENT. The whole ether, or space which constitutes the universe, and in which the sun, stars, planets, and comets are placed.

FISH BEAM, FISH BACK, or FISH-BELLIED RAIL. A beam or rail of iron, bellying on the under-side, as are now commonly those used on rail-roads.

FIXED AIR. Carbonic acid gas.

FIXED ALKALIS. Potass and soda. The term distinguishing them from the volatile alkali, ammonia.

FIXED AXIS. The axis about which a plane revolves in the formation of a solid.

FIXED BODIES, are generally those substances which are not to be separated into their various elements by fire, or by a corrosive menstruum, unless with great difficulty; such are gold, platinum, lime, &c.

FIXED ECLIPTIC. A certain imaginary plane, which never changes its position in the heavens from the action of any of the parts of the solar system on each other, but like a centre of inertia remains immovably fixed.

FIXED POINTS. In carpentry, the points at the angles of a piece of framing, or where any two pieces of timber meet each other in a truss.

FIXED STARS. Those which constantly retain the same relative position with each other, in contra-distinction to the planets and comets, which are constantly changing their relative positions.

FIXITY, or FIXEDNESS. The quality of a body which renders it fixed, or a property which enables it to endure fire, and other violent agents.

FLAGS. Thin stones, used in paving, from 1½ to 3 inches thick, and of various lengths and breadths, according to the nature of the quarry.

FLAKE WHITE. Lead corroded by the pressings of grapes, or the remains of the grapes after they have been pressed for wine. It is brought to England from Italy, and far surpasses in the purity of its whiteness, and

the certainty of its standing, all the ceruses of white lead made with us in common.

FLAIL. An instrument for thrashing corn.

FLAME. The subtlest and brightest part of fire, arising from the combustion of the gaseous particles which are liberated by the heat, these being in ordinary cases united with carbon.

FLANCHE or FLANGE. A projecting piece or table, for the more securely uniting together the different parts of beams, pipes, &c. by bolts which pass through the flanches.

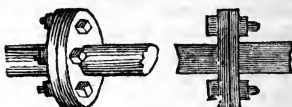

FLANCH CHUCK. A common simple chuck, formed like a flanch; but instead of holes being bored in it to admit bolts, it is furnished with several points, upon which the article to be turned is fixed; the other end being supported by the popit head.



FLANK. The straight part of the tooth of a wheel, which receives the impulse.

FLANK. That part of any body which adjoins the front, as flank walls or side walls.

FLAPS. Folds or leaves attached to the shutters of a window, which are not sufficiently wide of themselves to cover the sash frames, or exclude the light.

FLASHES. Sluices erected on navigable rivers to raise the water at such parts as are impeded by shoals, that the navigation may not be stopped. They are the same as locks upon canals.

FLASHINGS. Pieces of lead inserted in a wall, for covering other pieces laid down for gutters, &c.

FLATTING. A mode of painting in which the oil of turpentine only is used; the result of which is that the color remains without a glossy surface. It is chiefly used for in-door work. Nut oil and poppy oil are sometimes used instead of turpentine.

FLAX. The *bast* or inner bark of the flax plant, *linum usitatissimum*, which is spun into yarn for thread, and for weaving men articles.

FLEMISH BOND. (See *Bond*.)

FLEMISH BRICKS. Strong bricks used in paving. They are 6½ inches long, 2½ inches broad, and 1½ thick. One hundred set on edge will pave a square yard.

FLEXIBILITY. The property or quality of a body that enables it to be bent.

FLEXURE. The bending or curving of a line or figure.

FLIGHT. In staircasing, a series of steps, whose treads are parallel and terminate against a straight wall; or, in general terms, any series of stairs that lead from one apartment to another.

FLINT. (See *Silex*.)

FLINT GLASS. (See *Glass*.)

FLINT, *Liquor of*. Flints fused with a large quantity of potash, by which they become soluble in water, forming a solution of *silicated potash*, or liquor of flints.

FLOAT. Any thing which is so light as to be able to sustain itself on the surface of a liquid without having a tendency to sink.

FLOAT BOARDS. Those boards which are fixed to the rim or circumference of water-wheels, serving to receive the impulse of the stream, by which the wheel is put in motion.

FLOAT OF THE STEAM ENGINE BOILER. (See *Feed Pipe*.)

FLOATING BRIDGE. Either a collection of beams of timber, of sufficient buoyancy to sustain itself on the surface of a river, and reaching across it; or else a certain description of steam vessel, used only as a ferry boat.

FLOATING ELECTRO-MAGNET. (See *De la Rive, Marsh, Boss, &c.*)

FLOATING HARBOUR. A break-water, formed of large masses of timber, securely fastened together, which rise and fall with the tide.

FLOOD GATE. A gate or sluice, that may be opened and shut at pleasure, to give passage to or retain the water of a river, liable to be swollen by floods; or where it is necessary to dam up the stream for the use of a mill.

FLOOR. The lowest horizontal side of an apartment; it also signifies all those parts of a building which are upon the same level as the first floor, the ground floor, &c.

FLORENTINE GLASSES. The first name by which thermometers were known; given on account of their having been invented by the Florentines.

FLORID STYLE. A particular kind of Gothic architecture, of great beauty and elaborateness of workmanship; of which the splendid chapel of Henry VII. at Westminster is an example. The distinguishing characteristics are large arched windows, with numerous ramifications, consisting of cuspidated mullions, filled with a variety of polyfoils; highly ornamental buttresses, crowned with cupolas; walls filled with niches, pinnacles, and canopies, terminated with open mullion work; and the various projections adorned with crockets, finials, bosses, and other enrichments.

FLOSS SILK. The rawellings or loose silk,

broken off in winding the ~~shk~~ from the cocoon or bag of the silk-worm.

FLOUR. The finely ground meal of wheat, oats, or other grain.

FLOWERS. A general appellation given by the old chemists to all substances which have received a fine powdery form by sublimation, as the flowers of sulphur, the flowers of zinc, &c.

FLOWER POT. A particular kind of fire-work, that when ignited throws out a fountain of vivid spur-shaped sparks; these although so luminous, yet communicate no heat to the hand held in them. The following composition, which must be made very carefully, is to be rammed into small cases:— Take saltpetre, 4½ ounces; sulphur, 2 ounces; and lamp black, 1½ ounces. The ingredients must be of the best quality, and well mixed together.

FLUATES. Compounds of metallic oxydes, earths, and alkalies, with fluoric acid.

FLUENT, or FLOWING QUANTITY. In mathematics, is a variable quantity, which is considered as increasing or decreasing.

FLUID, or FLUID BODY, is that whose parts yield to the smallest force impressed upon them, and by yielding, are easily moved amongst each other; in which sense it stands opposed to a solid whose parts do not yield. Fluids are divided into *elastic* and *non-elastic*. The former are those which may be compressed into a smaller compass, but which, on removing the pressure, resume their former dimensions, as air. Non-elastic fluids preserve the same or very nearly the same bulk, under all circumstances of pressure, as water and other liquids.

FLUE. The long tube of a chimney, from the fire-place to the top of the shaft.

FLUID, *Electrical*. (See *Electricity*.)

FLUIDITY. The state or affection of bodies which renders them fluid.

FLUOBORATES. Combinations of various bases with fluoboric acid.

FLUOBORIC ACID, FLUORIDE OF BORON, or FLUOBORIC GAS. A gaseous compound of fluorine and boron, obtained by heating a mixture of vitrified boracic acid and fluor spar. It is colorless, of a pungent odour, highly deleterious to respiration, and extinguishes flame. Mixed with water, it forms a caustic, fuming solution, called *borohydrofluoric acid*. Neither the gas nor the liquid act upon glass, but they rapidly destroy almost all organic substances whatever.

FLUORIC ACID. A peculiar and highly corrosive acid, procured by distilling equal weights of fluor spar and sulphuric acid in a leaden retort. A gas passes over, which is the true fluoric acid, and which may be condensed into a liquid by cold. It is absorbable by water, and is very volatile, sending out

white fumes in the air. It rapidly corrodes *glass* and *flint*, from which it may be known from all other substances whatever. If a drop touch the skin, even for an instant, it completely disorganizes it, and produces a very painful wound.

FLUORIDES. Combinations of fluorine.

FLUORINE. An imaginary radical of the above acid.

FLUOSILICIC ACID. A combination of hydro-fluoric acid and silix, obtained by pouring hydro-fluoric acid on glass, when dense white fumes of the fluosilicic acid will escape.

FLUOR SPAR. Derbyshire spar, or fluate of lime.

FLUSH. A term used by builders and artisans, to signify even with; as a door may be flush with the walls, or receding from them.

FLUTING. The longitudinal grooves cut in the shaft of a column. In the Doric order there are always twenty, and these shallow. In the other orders, twenty-four, semi-circular, with a space between them, rounded at either end, except where the column is without a plinth, when they are carried quite down to the base.

FLUX. A general term made use of to denote any substance or mixture, added to assist the fusion of minerals. In the large way, limestone and Derbyshire spar are used as fluxes, but the most powerful are those of alkalis. The principal of which are *crude flux*, *black flux*, and *white flux*. Crude flux is a mixture of nitre and tartar. White flux is formed by projecting equal parts of nitre and tartar, by moderate portions at a time, into an ignited crucible. Black flux differs from the preceding in the proportion of the ingredients; in this the weight of the tartar is double that of the nitre.

FLUX AND REFLUX OF THE SEA. (See *Tides*.)

FLUXIONAL ANALYSIS, is the analysis of fluxions and fluents, distinguishable from the differential calculus by its notation, but in all other respects identical. Calculations by this mode conceive that all finite magnitudes are or may be resolved into infinitely small ones, supposed to be generated by motion, as a line by the motion of a point, a superficies by a line, and a solid by a surface; of which they are the elements, moments, or differences. The art of finding these infinitely small quantities, and working with them, is called the *direct* method of fluxions; and the method of finding the flowing quantities or fluents is what constitutes the *inverse* method.

FLUXIONS, is the magnitude by which any moving or flowing quantity would be uniformly increased in a given portion of time, with the generating celerity at any proposed instant, supposing it thence to continue invariable.

FLY. A set of two or more fanners placed on an axis, sometimes for the same purpose as a fanner, but more frequently to equalize the motion of a small piece of machinery, by occasioning a resistance of the air, and thereby preventing it running down too rapidly. Flies, therefore, answer in some degree the purpose of a pendulum; for example, the wheels of the time movement of a clock are terminated by a pendulum; the wheels of the striking part by a fly. All machinery must end either in a fly or a pendulum, or it must have a certain part which acts upon a similar principle of resistance; such as the paddle wheels of a steam-boat, the wheels of a carriage, the sails of a windmill, &c.

FLY WHEEL. A large heavy wheel, attached to machinery to equalize the motion of it. It acts exactly upon the contrary principle to the simple fly; its action being to collect the surplus power of the machine when it can be spared, and to apply this collected power when afterwards wanted. For example, in the working of the crank B in the following cut, it has no power to turn the axle, when at the points C C, and would therefore stop; but the momentum of the fly wheel A A carries it beyond the points C C, when the crank acts by its own power again.

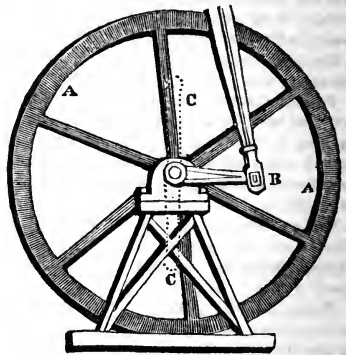

FLYER, ELECTRICAL. A wheel of several wires, projecting horizontally from the same centre; the outer end of them all being turned at a right angle and pointed, the points being all directed the same way. If such a wheel be supported on a wire or pivot, which is fastened upright on the prime conductor of



an electrical machine, and the machine put in action, the fluid will fly from each of the points; and the action of this upon the air will give to the flyer a rapid motion.

FLYERS. A straight row of steps or stairs.

FLYING BUTTRESS. (See *Buttress*.)

FLY POWDER. The black colored powder obtained by the spontaneous oxidisement of metallic arsenic in the air.

FOCAL DISTANCE. In the conic sections, is the distance of the focus from some fixed point, viz.: from the vertex of the parabola, and from the centre in the ellipse and hyperbola.

FOCUS, is that point in the transverse axis of a conic section, at which the double ordinate is equal to the parameter or bounding line. From which arises this property, that when there are two foci, as in the ellipse: if light be reflected from one focus, and strike the surface of the curve, it will be reflected to the other focus, the heat and light of the luminous body being there concentrated; hence the name focus, or *burning point*. Focus, in optics, is a point wherein several rays concur, or are collected, after having undergone either refraction or reflection. The focus of a lens, or combination of lenses, is the distance between the centre of the lens and the point in which the rays are concentrated. Some lenses have no focus. A *virtual focus*, or *point of divergence*, is the point from which lines tend. It is therefore contrary to the true focus, although it may, perhaps, be the same point.

Focus, Geometrical and Refracted. The point in which the rays of light ought, according to their known laws, to be concentrated, when reflected from a concave mirror, or refracted through a lens, is termed the *geometrical focus*; that in which they are actually formed, is the *refracted focus*. These foci are separated from each other in proportion to the degree of spherical aberration.

FOIL. Among jewellers, is a thin leaf of metal placed under a precious stone to increase its brilliancy, or give it an agreeable or a different color. Foils are made of plates of copper, rolled and beaten as thin as possible, then boiled in an earthen vessel with equal quantities of tartar and salt. When they have assumed a good white color, they are taken out, dried, and afterwards polished with whiting. If desired of a particular color, it is only necessary to varnish them with that colored varnish, observing that all the colors must be quite transparent, such as lake, Prussian blue, verdigris, and others.

FOIL. In architecture; all those rounded or leaf-like forms, seen in Gothic windows, niches, crests, battlements, &c. are called foils, and are distinguished according to the number of them, which are combined to-

gether into the names *Tre-foil*, *Quatre-foil*, *Cinque-foil*, &c. (See each of these terms.)



FOLDING DOORS. Two doors which are hung on the two side posts of a door frame, and open in the middle.

FOLDING JOINT. A joint made like a hinge.

FOLIAGE. In the fine and ornamental arts, an artificial arrangement of leaves, fruit, &c.

FOLIATION. (See *Feathering*, *Cusps*, and *Foils*.)

FONDUS. That particular kind of painting calico, paper-hangings, &c. in which the colors are blended into each other.

FONT. The basin to hold baptismal water.

FOOT of a press or other machine, is the foundation upon which it stands; also a measure of length, derived from the human foot, containing 12 linear inches. A *square foot* is 144 inches, or a square surface 12 inches on each side. A cubic foot is a cube of 12 inches in length, breadth, and thickness. Its content therefore is $12 \times 12 \times 12$, or 1728 cubic inches.

FOOTINGS. The lower part of a brick or stone wall, in which a part of the bricks project beyond the general surface.

FOOT IRON. An iron fastened to the foot, in order to preserve the shoe while digging.

FORCE. Whatever tends to produce motion, or a change of motion in any body, is called force or power. It may be artificial, such as the force of steam and gunpowder, which constitute expansive forces. Natural forces are of two kinds; the first derived from the bodily strength and vital energy of animals, human power, &c.; the other kind is the effect of the atmosphere, water, and other elements, as acted upon by the centrifugal, centripetal, electric, magnetic, and chemical forces. Force is measured by the mechanical result produced: thus, if a blow be given to the ball A, which drives it to B, the force is equal to A B. If A is driven to C, the force would be A C. In the calculation of forces, allowance must be made at

all times for any thing which can increase or diminish the effect, such as friction, gravity, &c. When a body is in motion, the force it acquires, is the weight of the body multiplied by its velocity; but when the body is at rest, such as pressing upon any thing, or suspended from a cord, its force is its weight only. Forces may be either *accelerative*, *retardive*, *constant*, or *variable*.

FORCE, Centrifugal. (See *Centrifugal*.)

FORCE, Centripetal. (See *Centripetal*.)

FORCES, Composition and Resolution of.

Are the laws which explain the result produced by several forces acting in different directions: thus, the power which keeps up a boy's kite, may be *resolved* into three forces. That of the wind, to drive it along and upwards. That of the string, to pull it back; and that of gravity, to draw it down. These forces act variously until they exactly balance each other, when the kite remains at rest, and a single force only becomes apparent, which is, a pulling at the string; this, therefore, is the *composition* of the three acting forces.

FORCEPS. A general term for all small tools which act upon the nature of tongs, such as pincers and pliers.

FORCE PUMP. A pump which is capable of driving a stream of water above the pump barrel by means of compressed air. It is shown in the margin, where the lower pipe is supposed to stand in the well of water. When the handle of the pump, and consequently the piston is drawn up, a vacuum being produced below the piston, the pressure of the atmosphere on the water of the well drives the water through the valve at the bottom of the pump barrel, and thus the barrel is filled with water. When the handle is forced down again, the water instead of returning, (the valve being now shut,) passes to the side vessel, which has a tube in it, reaching to near the bottom: when, therefore, the water covers the bottom of this pipe, the air above becomes compressed, and forces the water up the pipe into the air, or into a vessel connected with the pipe above.

FORE FRONT. The principal or front entrance to a building.

FORESHORTEN. In painting, the diminution in length which the parts of objects appear to have when looked at obliquely.

FORGE. The name either of the furnace where wrought iron is hammered, and fashioned with the aid of heat; or the great workshop where iron is made malleable.

FORK CHUCK. This useful appendage to the lathe may be understood by an inspection of the figure below. The part which screws to the mandril has on the outer side a square hole, in which forked pieces of iron, (like that represented,) of different sizes, according to the strength required, are placed when in use. This chuck always requires the work to be supported at the other end.

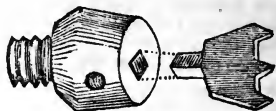

FORM. In printing, an assemblage of pages or lines of type, arranged in order, ready to be printed from. Every form is inclosed in an iron chase, wherein it is firmly locked by a number of small wedges of wood, called quoins. There are two forms to every sheet of a book, one for each side of the paper; and each form consists of more or fewer pages, according to the size of the book.

FORMIATES. Combinations of the formic acid and certain bases.

FORMIC ACID. An acid obtained from ants.

FORMULÆ. Characters or symbols, by which certain rules or quantities in mathematics are represented; or in chemistry, by which substances, either simple or compound, are known.

FORUM. An open space, used among the ancients for public assembly.

FORNERING. A method sometimes resorted to for stopping a leak in a vessel at sea. It consists in stitching loosely a quantity of oakum upon a sail, which is drawn under the vessel's bottom, and by the flow of water through the leak, the oakum is drawn into the aperture.

FOUNDATION. That upon which any thing rests, particularly the lower part of a house, wall, &c. or the beds of earth, concrete, &c. upon which it stands.

FOUNDRY. A place in which founding is carried on.

FOUNDING. Melting, and afterwards casting in moulds prepared for the purpose, various articles in metal; the general subject being divided into iron founding, brass founding, copper founding, bell founding, bronze founding, and type founding. The same operation in lead, tin, silver, gold, zinc, &c. is usually called casting.

FOUNT, or FONT. Among printers, a set of types, sorted for use, that includes large and small capitals, single and double ordinary letters, points, lines, numerals, &c. as a fount of pica, long primer, brier, &c.

FOUNTAIN. A machine or contrivance by which water is violently spouted or darted

up. There are various kinds of artificial fountains, but all formed by a pressure of one sort or another, upon the surface of the water, viz.: either the pressure or weight of a head of water, or a pressure arising from the spring or elasticity of the air. To construct the first kind of fountain is extremely easy, nothing more being requisite than to have a pipe, which leads from a reservoir, higher than the mouth of the jet; when the water will spout to a height nearly equal to the reservoir itself, if the conveying pipe be more than half an inch in internal diameter. Water spouting from and falling upon rock-work, is the most effective in garden scenery.



FOUNTAIN GLASS. A pneumatic apparatus, showing the elasticity of the air. It is a glass vessel with a brass top, and a tube within it, extending to near the bottom of the glass. When this glass is partly filled with water, and placed under a tall receiver of the air pump, the air being exhausted by the action of the pump, the elasticity of that air which remains within the vessel drives the water through the tube, and makes it play into the receiver like a fountain. This action continues either until almost all the water is driven out, or else until the air has become so rarefied that it no longer has sufficient force to overcome the resistance.



FOUNTAIN OF CONDENSED AIR, will be understood from the structure of the fountain glass. The only difference being that the present instrument throws up the water it has been previously partly filled with, in consequence of air being first condensed into the vessel by means of a condensing syringe screwed to the top of it. A stop cock, therefore, is necessary on the upper part, in order

that the jet may be substituted for the condensing syringe, as occasion requires.

FOUNTAIN OF CIRCULATION. A curious constructed glass apparatus, in which a colored liquid is seen to flow upwards. It is represented in the margin, and consists of a large glass tube with a bulb at each end, and a small tube connected with each bulb, communicating with the lower one B, but not with A; this small tube being twisted and contorted in and out in any fanciful manner. The two large balls, and the tube between them, being filled with a colored fluid, the air is completely exhausted from the rest of the apparatus, except a small bubble left in the end of the small tube nearest to A, and the whole hermetically sealed. The ball A being turned upwards, the fluid will pass from B up the small tube, and through all its contortions, till it finds its level, near the top. Upon reversing the whole, so that B becomes the higher ball, the fluid falls from B to fill up the former loss of fluid in A, and consequently the fluid in the small tube will follow it, being pressed by the elasticity of the small bubble of air left in it. The whole ought to be inclosed in a case, so that the larger tube and balls are hidden.

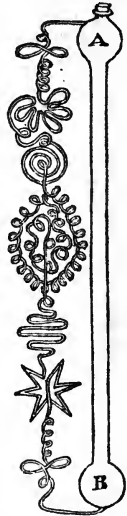

FOUNTAIN PEN, is a pen contrived to hold a greater quantity of ink than usual, so as to supply the writer for a considerable time, without taking a fresh supply.

FOUR-WAY COCK. A description of valve, much used in steam engines, to pass the steam to and from the cylinder. The following is a vertical section of one:—A is a pipe connected with the condenser. B, with the boiler. C, with the top of the steam cylinder; and D, with the bottom of the cylinder. E is the key of the cock, which is capable of being turned round, so as to stretch across

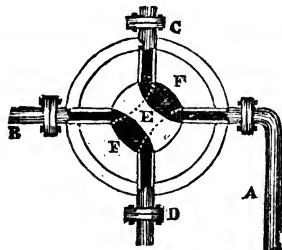

from E to F. In its present position, the fresh steam is passing to the bottom of the cylinder, and the waste steam is passing from the top of the cylinder to the condenser. Upon giving the key of the cock a quarter turn, so that it reaches from E to F, B would be connected with C, and A with D; consequently the action would be reversed, and the steam pass away from the bottom, and be admitted to the top of the cylinder.

FOXING. A term applied to beer, when it turns somewhat sour and musty in the fermentation.

FOX-TAIL WEDGING. A method of fastening a tenon in a mortice, by means of splitting or cutting a piece out of the tenon, so that a wedge may be driven in after the tenon is in its place.

FRACTION. The part or parts of a whole quantity: thus, if any thing be divided into eight equal portions, each portion would be a fraction, as one-eighth, three-eighths, five-eighths, &c. which would be expressed in figures, by two numbers, with a line drawn between them, as $\frac{1}{8}$, $\frac{3}{8}$, $\frac{5}{8}$. The lower of these figures, in every case, is called the *numerator*, and shows how many parts the integer is divided into; the upper figure is called the *denominator*, and indicates the number of these parts that is to be taken. Fractions may be either *proper* or *improper*, *simple*, *compound*, *complex*, or *mixed*. A *proper* fraction has the upper figure less than the lower, as $\frac{1}{2}$. An *improper* fraction has the upper figure equal to it, or else greater, as $\frac{5}{3}$. A *simple* fraction is that which consists of a single denominator and numerator, as $\frac{2}{3}$. A *compound* fraction consists of two or more simple fractions, as $\frac{1}{2}$ of $\frac{2}{3}$. A *complex* fraction is that whose parts are both fractional, as $\frac{\frac{1}{2}}{\frac{2}{3}}$. A *mixed* number is a fraction and whole number united, as $4\frac{1}{2}$, $9\frac{3}{4}$, &c.

FRAME. Various pieces of wood, metal, &c. so bent or joined together as to inclose a space.

FRAMING. All the timbers of a house are so called, such as the partitioning, roofing, flooring, &c.

FRANÇOIS'S STEAM ENGINE. An engine invented by M. François, professor of philosophy, at Lausanne, for the draining of waste land, for which purpose it is well adapted, equally on account of its simplicity and efficacy. The machine is composed of the pipe B, the lower end of which is inserted in the water, and the upper end enters the receiver A; a pipe D proceeds from the receiver, as high as it is required to elevate the water, and has a cock or valve at L. Another pipe having a stop cock at I, conducts steam from the boiler C into the receiver A. E is a bucket turning on an axis: to this bucket two levers are fixed, having

joints at the top; that is, turning partly on their axes. G is a trough which conducts away the water which may be raised by the engine. The novelty of this engine consists in the simple means by which it is made to be self-acting. When the steam, flowing from the boiler into the receiver, forces the water which it may contain up the pipe D, and is emptied into the swinging bucket E; this bucket being filled, turns on its axis, and empties itself into the trough G, and is afterwards brought into the horizontal position by the counterpoise F. However, as the bucket turned down, it depressed the lever J, and raised the lever K; the lever J acted on the lever beneath G to shut the cock I, and the lever K to shut L. The further passage of the steam from the boiler into the receiver was shut, and the water in the eduction pipe prevented from flowing into the receiver. A valve at H, in the trough, was also at this moment raised, which permitted a small quantity of cold water to fall into A, and condense the steam it contained. The pressure of the atmosphere then forced the water into the receiver, and the counterpoise F restoring the swinging bucket to its former position, the cocks I and L are opened, the steam escapes from the boiler, and the water is again driven out; and this takes place five or six times in a minute.

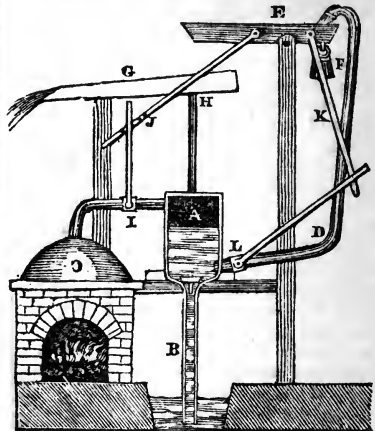

FRANKFORT BLACK. A vegetable charcoal, procured by calcining vine branches, and other remains of the vinegar manufacture of Germany.

FRANKINCENSE. The gum of olibanum; it is of a powerful and pleasant smell, for which reason it is highly esteemed, and used both as a vulnerary and to mix in pastiles, and the incense used in religious ceremonies.

FRANKLIN'S HYPOTHESIS of electricity is, that there is but one electrical fluid, the

redundancy of which occasions all those appearances which Du Fay attributed to that which he called the vitreous fluid, and its deficiency causing the effects attributed to the resinous fluid. The former, Franklin called *plus*, or positive; the latter, he called *minus*, or negative.

FRAUENHOFER'S LINES. This optician observed, when looking at a very small ray of light passing through a narrow chink, with a very excellent prism held close to the eye, that it was intersected with a great number of fine black lines, the distances and regularity of which are different in different media; so much so, that the refractive power of various media may be determined by the condition of these minute lines, which are called Fraunhofer's lines.

FREESTONE. A stone, consisting of sand united together without any apparent cement. It is rather soft, especially when fresh quarried, but much used for building purposes, it being easily cut into any required form, and when of good quality it looks well, and possesses considerable durability.

FREEZING, OR CONGELATION. The transformation of a fluid body into a firm or solid mass, by the action of cold.

FREEZING MIXTURE. A preparation for the congelation of water and other fluids. An equal mixture of snow, or pounded ice, and salt, sinks the thermometer to about 30°. Equal parts of nitrate of ammonia and water sinks it 46°. Muriate of lime, 3 parts, and snow or ice, 2 parts, sinks it 80°, or from the freezing point to 48° below zero.

FREEZING POINT, denotes the point or degree of cold shown by a mercurial thermometer, at which certain fluids begin to freeze, or when frozen at which they begin to thaw again. On Fahrenheit's thermometer this point is at +32 for water, and at -40 for quicksilver. Those fluids freezing at these two points respectively.

FRESH PUMP. (See *Leslie*.)

FRENCH BERRIES. The fruit of the *rhamnus infectorius*, called by the French grains d'Avignon. They are used in dyeing, and yield a pretty good yellow color, though one void of permanency.

FRESCO PAINTING. An art of painting in water colors upon the surface of wet stucco or plaster, so that the colors are imbibed by the wall when laid on. The Cartoons at Hampton Court, by Raffaele; and the ceiling of the Hall at Greenwich, by Sir James Thornhill, are splendid examples.

FRETTED VAULTS. Vaults which are much intersected with small groins or ribs.

FRET-WORK. Any small and delicate carving.

FRET. The ornamental iron-work below the bars of a grate, so called because often fashioned of the fret ornament, which is any

combination or intermixture of straight lines. The following is an example of the fret ornament:—

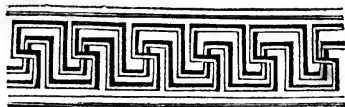

FRIABILITY. That quality of certain bodies whereby they are easily reduced to powder.

FRICTION. The action of rubbing two bodies together, or the resistance in machines caused by the motion of the different parts against each other.

FRICTION BALLS. A contrivance for moving heavy weights around a centre; such, for example, as a block of marble from which a piece of statuary is to be cut. The block is placed upon a circular plate of iron, which fits upon a similar plate beneath. A number of iron or stone balls are placed between the two plates, generally in a groove around the edge, there being either a channel cut in the touching surfaces of the two plates, sufficiently deep to prevent the balls rolling out, or else a rim is put round the lower plate with the same object.

FRICTION CLUTCH. A mode of putting machinery in and out of gear, when the velocity of the parts is very great.

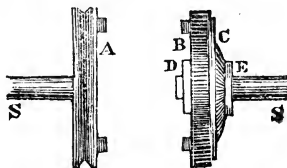

A is a pulley, revolving freely on the shaft S. B is another pulley, also capable of revolving on the shaft. C is a spring, secured in its place by the pin E, and forcing the pulley B against the collar D, which is fixed permanently to the shaft. When motion is required to be communicated to the shaft S, the pulley A is moved towards the pulley B, and the teeth projecting from the side of A, taking hold of the teeth of B, carries both pulleys round together. When the friction of the pulley B against the collar D gradually overcomes the inertia, it carries the shaft and machinery attached to it all round together.

FRICTION CONES. A method of disengaging and re-engaging machinery, and that without the sudden jolts to which some other modes of coupling subject it to.

On the moving shaft A is fixed a cone C, and on the shaft B is another cone D, made

to fit in the cone C. The cone D is moveable on a square part of the shaft B, and may, by a lever, be moved in and out of the gear. When the cone D is moved forward, the cone C receives motion by friction against its internal surface.

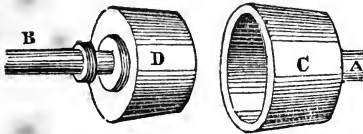

FRICITION ROLLERS, are small cylinders fixed between the axis on which a pulley turns, and the pulley itself, the hollow axis of the latter being made larger in order to receive them. There may be about six or eight of them; they are formed like little cylinders, fixed each on its own axis, and working at the two ends into a corresponding number of holes made equally distant, in a brass ring, at each side, which is fastened to the pulley itself. One side of the cut shows the friction rollers without the ring holding the end of them; the other shows the whole complete, the rollers being then scarcely perceptible.

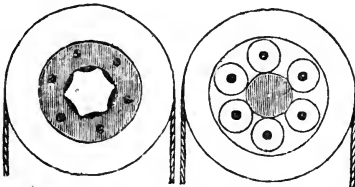

FRICITION WHEELS. When the axle of a wheel works in an immoveable bush, the friction is often very great; to prevent this, sometimes the axle is made to rest upon the circumference of two wheels, which turning on their centres, and bearing the axle only on two points or lines, very much diminish the friction. In the cut the axle C is supported on the friction wheels A and B.

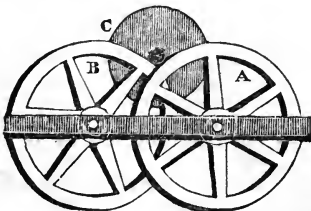

FRIESLAND GREEN. Ammoniac-muriate of copper; the same as Brunswick green.

FRIEZE. A large flat member of a building, between the architrave and the cornice.

It is mostly ornamented with *bas reliefs*, or the figures of animals; hence it is sometimes called *zoophorus*.

FRIGID ZONES. Those two portions of the earth's surface which surround the north and south poles, extending towards the equator $23^{\circ} 28'$ each, making a circle of $46^{\circ} 56'$, and which is bounded by one or other of the polar circles; the north frigid zone by the arctic circle; the south by the antarctic.

FRIGORIFIC. Producing cold.

FRIGORIFIC MIXTURES. (See *Freezing Mixtures*.)

FRIGORIFIC PARTICLES. A term used by some early philosophers to denote what they considered the matter of cold, as modern philosophers make caloric the matter of heat.

FRISKET. An iron frame, forming part of a printing press, used to keep the sheet of paper on the tympan, and to prevent the margin from being blacked during the operation of printing.

FRIIT. The materials of glass are first mixed together, and then calcined, though not melted; in this state they are called fritt.

FRIZING OF CLOTH. A term applied to the forming the nap of cloth into a number of little hard burs or prominences, covering almost the whole of the ground.

FRONTISPIECE. In architecture, signifies the decorations upon the principal front of a building, as the frontispiece of Westminster Hall, Abbey, &c.; synonymous with portail.

FROST. That state of the atmosphere which causes the congelation or freezing of water, or other fluids into ice.

FROST BEARER. (See *Cryophorus*.)

FROST SMOKE. A phenomenon peculiar to the polar regions. Previous to the freezing of the sea, it smokes like burning turf land, and a fog or mist arises, called *frost smoke*. This cutting mist frequently raises blisters on the face and hands, and is very pernicious to the health. It appears to consist of small particles of ice, and produces the sensation of needles pricking the skin.

FROSTED WORK. In architecture, is a species of work imitative of ice formed by irregular drops of water, bearing a rude resemblance to clustered icicles.

FROTTERINGHAM'S PYROMETER, combines simplicity with considerable delicacy. It is also intended to indicate the changes of atmospheric temperature.

A is a bar of iron four feet long and an inch and a quarter wide, having a polished brass surface screwed to it by steel screws, which are fitted to short slips in the brass to allow of the expansion of the iron bar, without permitting that of the brass ornamental surface to affect the hardened steel apex. This apex moves the lever B, which raises the lever C, both turning on fine axes. A

chain from the extremity of C is lapped twice round the pulley D, on the axis of the index G, which moves round a graduated circle. The counterpoise F brings back the index as the levers fall.

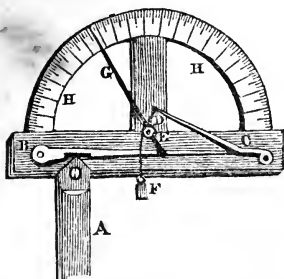

FRUSTRUM. In geometry, is a part of a solid next the base, left by cutting off the top by a plane parallel to the base, as the frustrum of a cone, pyramid, &c.

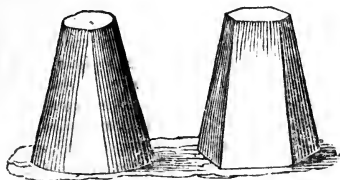

FRUSTRUM. In the fine arts, is used to designate a broken statue, a fragment of a gem, or an antique coin or medal.

FUEL. Any solid material capable of supporting its own combustion, and at the same time giving out heat. The ordinary fuels are wood, coals, coke, and charcoal.

FULCRUM. In mechanics, the prop or support upon which a lever is sustained.

FUNGATES. The combinations of a peculiar acid, extracted from mushrooms.

FUNGIC ACID. (See *Fungates*.)

FUNGIN. The fleshy part of mushrooms deprived by alcohol and water of every thing soluble.

FULGURATION. The sudden brightening of the melted gold and silver in the cupel of the assayer, when the last film of vitreous lead and copper leaves their surface.

FULIGINOUS. Smoky, or of the color of smoke.

FULLER'S EARTH. A particular kind of clay, of a greenish color, unctuous feel, and which does not adhere to the tongue, nor yet form a plastic paste with water. It has the power of strongly absorbing greasy matters, and is therefore valuable in cleansing woollen and other goods. It is found abundantly in

Bedfordshire, Berkshire, Hampshire, and Surry.

FULLING. The cleansing of wool and woollen cloths from the greasiness with which the former is naturally imbued.

FULMINATING POWDERS, OR FULMINATES. Highly detonating compounds of gold, silver, mercury, &c. formed by acting upon their nitric solutions by alcohol, in some cases by ammonia.

FULMINATION. An inflammation so sudden and violent that a loud noise is produced.

FULMINIC ACID. An acid supposed to be of the same composition as cyanic acid, but known only in that particular state of union with the metals in which a fulminating powder is produced.

FUMIGATION. Smoking, or the submitting objects or apartments to the action of particular fumes, such as the smoking of provisions, the disinfecting rooms by chlorine, the burning of pastiles to remove disagreeable smells, &c.

FUNCTION. A quantity is said to be a function of another quantity, when its value depends on that quantity and known quantities only.

FUNICULAR MACHINE, is a term used to denote an assemblage of cords, by means of which two or many powers sustain one or many weights.

FUNNEL. A conical or bell-shaped instrument with a narrow tube, for facilitating the transferring of liquids or small substances from one vessel to another.

FURLONG. An English measure of length, equal to the eighth of a mile, or to 220 yards.

FURNACE. Any inclosed fire-place constructed so as to generate a great degree of heat, and to continue that heat for a considerable length of time. Furnaces are of various kinds, according to the object for which they are intended; such as the glass blower's furnace, the founder's furnace, the chemical furnace, the baker's oven, &c. The following description of two or three furnaces will explain the ordinary construction of all furnaces:—The first cut represents a chemical furnace of a form and size convenient for experimental purposes; the one side of the cut showing the external, the other the internal structure of it. It is in three parts, which fit on to each other. A is the semi-circular cap which reverberates the heat downwards; upon the top is a hollow socket on which a short tin chimney is fitted occasionally. B is the part where the fuel, (charcoal,) is placed. C is the ash-hole. D is an earthenware cup or evaporating dish, which rests upon a ledge left inside the top of B. E is a plate of sheet iron for the fuel to rest upon. It is pierced with holes for the sake of draught. The iron plate rests upon a

small ledge left near the bottom of B. There are, moreover, three holes, one in each compartment; that in A for the introduction of small retorts, tubes, &c.; that in B for the supply of fuel; and that in C for the removal of ashes, and also to supply air to the fire. Small pieces of baked clay are made to fit these holes when occasion requires.

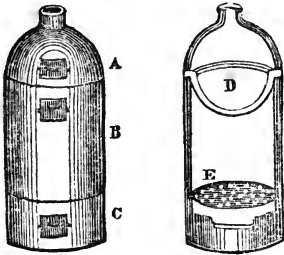

The next represented is the air furnace, and is that usually employed for the melting of metals. The charcoal, coke, or coal, is placed upon the grating in the centre of the figure, B; and the crucible, containing the metal to be melted, is placed in the centre of the fire, A. The chimney does not ascend perpendicularly from the fire, but communicates with it by a lateral opening. There is an opening, (covered by the iron plate C,) above the crucible, for the purpose of taking it in and out of the furnace.

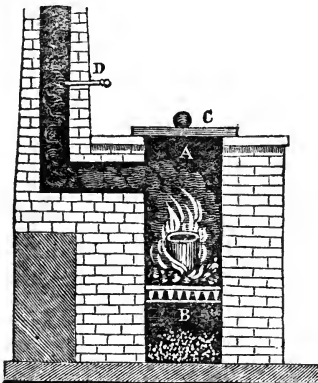

The following cut shows an air furnace of the reverberatory kind. A is the ash-pit, above which is the grate. B the door. C the hearth, and D the chimney. In this sort of furnace the heat generated is not made to act immediately upon the crucible, but the fire-place is arched over, and a horizontal flue passes along to about four times the length of the fire place, and opens at the farther

end into the bottom of the chimney. The flame and heated air are reflected or reverberated from the arched roof above the fire, and carried from thence along the flue to a retort placed at the bottom of the chimney, as at E. This kind of furnace, from the great heat which may be procured by it, is extensively used in the iron manufacture; the proper fuel for it is coal. (See *Blast Furnace, Glass Furnace, Brande, Davy, Faraday, &c.*)

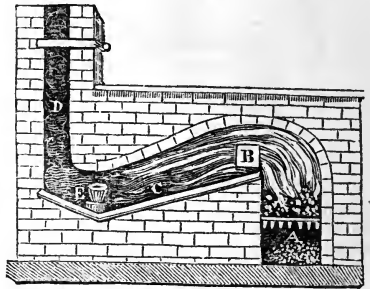

FUSEE. A mechanical contrivance for equalizing the power of the main-spring of a watch; for, as the *power* of a spring decreases in proportion as it *runs down*, or in proportion as its tension is diminished, it is requisite that it should act upon such a wheel as would make due allowance for the inequality of the spring's action; such an one is the fusee. The cut shows that as the power of the spring diminishes, the chain which it winds up will be on a wider part of the conical fusee, consequently a less power is necessary to continue the same tension on the chain. A is the fusee. B the barrel which contains the main-spring.

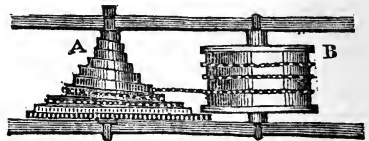

FUSIBLE METAL, OR ALLOY. *Darcey's Alloy. Newton's Fusible Metal.* An alloy which melts in the heat of boiling water. It is composed of 3 parts by weight of tin; 5 of lead; and 8 of bismuth.

FUSING POINT. The degree of heat at which any solid body melts. The fusing points of the common metals are tin 442°; bismuth 497°; lead 612°; zinc 773°; silver 1173°; copper 1996°; gold 2016°; cast-iron 2786°.

FUSION. The melting of a solid substance by the application of heat.

FUST. The shaft of a column, (an old word.)

FUSTIAN. A species of coarse, thick, twilled cotton, generally dyed of an olive, leaden, or other dark color. The different kinds of fustian are known by the names of

common fustian, or *pillow*, corduroy, velvet, velveteen, and thicksett.

FUSTIC, or YELLOW WOOD. This wood is the produce of the *morus tinctoria*, which grows in the West Indies; it is used in dyeing yielding copiously a durable yellow color.



The seventh letter of the English alphabet; having two sounds—a hard sound before *a*, *o*, and *u*, as in *gain*, *go*, *gun*; and a soft sound before the other vowels, as in *gem*, *ginger*, *dingy*.

In old writings G is sometimes substituted for c, v, and for n; as *Gaius* for *Caius*, *Gascon* for *vasco*, *aggelus* for *angelus*; also Gu is occasionally put for W, as *Guillaume* for *William*.

GABION. A wicker basket, filled with earth, and used in fortifications to shelter men from an enemy's fire.

GABLE. A triangular wall, or wood-work at the end of a roof.

GABLETS. Small gables; triangular decorations of buttresses, pinnacles, &c.

GABLE WINDOW. A window in the gable of a building.

GAGE. (See *Guage*.)

GALACTOMETER. An instrument for ascertaining the specific gravity of milk. (See *Lactometer*.)

GALAXY, or MILKY WAY. That long luminous tract or zone, which encompasses the heavens, forming nearly a great circle of the celestial sphere. It is inclined to the plane of the ecliptic at about an angle of 60° , and cuts it nearly at the solstitial points. The ancients had many singular notions as to the cause of this phenomenon; but modern astronomers have long attributed it to a great assemblage of stars; and Dr. Herschel has confirmed these conjectures, having discovered, in a space about 15° long by 2° broad, no less than 50,000 stars.

GALBANUM, is the concrete juice of the *bubon galbaniferum*, a shrubby plant of the East Indies, Syria, and Persia, whence the gum is imported. It is now but little used, either in varnishing or in medicine.

GALENA. The sulphuret of lead.

GALLIEE. A small gallery or balcony at the west end of a collegiate church, from which visitors might view the service beneath; in which persons did penance, &c. exposed to the gaze of those beneath; any division of a church set apart for these and similar purposes is called a galilee.

GALILEAN TELESCOPE. A simple astronomical telescope of two glasses only; that nearest the object being doubly convex, and that near the eye a doubly concave lens, as is seen in the following cut, where C is the object. B the object, or field glass. A the image of the object, as thrown in parallel lines towards the eye by the double concave lens near it:—

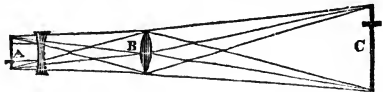

GALL NUT. A round, nut-shaped excrescence, common to the oak, and occasioned by the puncture of an insect. The gall nuts of commerce are hard, woody, and heavy. In medicinal qualities, powerfully astringent, and are much used in the arts of dyeing and ink making. In chemistry, their solution is used as an excellent test for iron, precipitating it of a purplish black color.

GALL OF ANIMALS, chiefly Ox Gall. A secretion formed in a bladder which is attached to the liver, and which communicates with the stomach of animals. It is of a dark green color, of an intensely bitter taste, and of strongly alkaline properties. In its natural state it is much used by the scourers of clothes, carpets, and stuffs; and purified, is of the greatest importance to miniature water color painters, in increasing the brilliancy and durability of ultramarine, carmine, &c.; and in making them lay evenly on the paper or ivory, removing at the same time all greasiness.

GALL OF GLASS, called also **SANDIVER**, is the neutral salt skimmed off the surface of melted crown glass.

GALLATES. Salts formed by the gallic acid with the alkalis, alkaline earths, or metallic bases.

GALLERY. In architecture, a long narrow room, the width of which is at least three times less than its length, by which proportion it is distinguished from a saloon. A number of rooms opening into each other is often called a gallery, especially if the walls are decorated with fresco painting, or covered with other paintings. In a mine, or

a fortification, a gallery is merely a passage from one apartment or division to another.

GALLIC ACID. This acid derives its name from the gall nut, from which it may be extracted by moistening bruised gall nuts, and exposing them for four or five weeks to a temperature of about 80°; a mouldy paste is formed, which is to be squeezed dry, and digested in boiling water. It then affords a solution of gallic acid, which may be whitened by adding animal charcoal. Gallic acid, when pure, is in the state of white needle-shaped crystals, sour in taste, and of a peculiar smell, when heated. It is very soluble in hot water, and sparingly so in cold. It also dissolves in alcohol and in ether.

GALLIPOLI OIL. An inferior kind of olive oil, imported from a port so named in Otranto, in Italy.

GALLIPOT. The name of a white, semi-solid, viscid rosin, found on fir-trees.

GALLIPOT VARNISH. Take 12 ounces of pounded gallipot; 5 ounces of white glass, pounded; 2 ounces of Venice turpentine; and 32 ounces of essence of turpentine. The only use of the glass is, to prevent the union of the small particles of gallipot with each other, it being necessary that this should be prevented, which is done by the glass intermixing with the other ingredients.

GALLY, or GALLEY. In printing, the frame into which the compositor empties the lines out of his composing stick, and in which he ties up the page when completed. Common galleys are made of wood, and have a flat bottom, and a ledge, a little more than half the height of the types, along one side, and at the end. Other galleys have a ledge on both sides as well as one end, with a groove to admit a false bottom, called a *galley slice*.

GALVANIC APPARATUS. (See *Battery, Decomposing Apparatus, Davy, Faraday, &c.*)

GALVANIC BATTERY. Any arrangement of galvanic circles, made so as to produce an effect greater than a simple circle could occasion. (See *Cruikshank, De la Rue, Grove, Smee, Couronne de Tasses, Calorimotor, Wollaston, &c.*)

GALVANIC CIRCLE. (See *Circle.*)

GALVANIC MULTIPLIER. (See *Galvanometer.*)

GALVANIC TROUGH. (See *Cruikshank.*)

GALVANISM. That science which explains the facts and laws of a particular kind of electricity, in which the fluid is put in motion not by friction but by chemical means. As soon as any chemical action takes place in any compound, the capacity of the constituents of the compound for the retention of the electric fluid is altered, and that fluid which was before latent becomes sensible; one portion of the compound having a capacity for more fluid; the other being ready to

part with a portion of what it at first had. These disturbances occasion re-action, so as to occasion other changes; sometimes chemical, at others mechanical or physiological. The laws explanatory of the motives and properties of the electric fluid when thus disturbed; the effects which take place when a current of the electric fluid is made to pass through or near to a conducting substance, and the arrangement and management of the apparatus necessary to produce those effects constitute the science of galvanism.

GALVANIZED IRON. A name given to sheets of iron when they are tinned, by first dipping them into a bath of melted zinc, and when this has adhered so as to cover them properly, plunging them into a second bath of melted tin. Iron plates thus prepared resist for a long time the effect of damp, on account of the galvanic action of the various metals.

GALVANOMETER AND GALVANOSCOPE. Instruments which indicate the passage of a small quantity of the galvanic fluid through or around different circuits, by showing its effects upon a freely-suspended magnet. The only difference in the two instruments is, that the latter is attended by some scale of degrees, by which the power of the fluid can be exactly ascertained, the former being without that scale. The cuts are therefore those of galvanoscopes. The simplest form of the galvanoscope is as follows, as originally suggested by Schweigger:—It consists of a wire bent once round a magnetic needle, as A A, and terminated by a mercury cup at each end, B, C, the needle being free to turn horizontally on its axis.

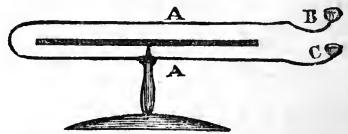

The action of this instrument is explained under *Electro-Magnetic Multiplier*, where

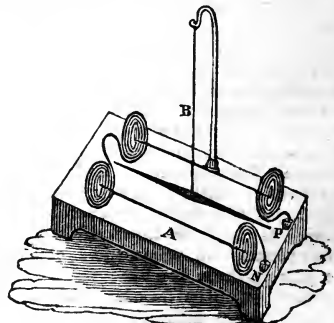

also another cut is given of the same instrument. Another quite different form has been given to the galvanoscope; the needle being suspended by a fine fibre of silk, and the coils of wire bent so as to form four flat spirals, all formed of the same wire, and consequently all conveying the current in the same direction. A is the stand. B the thread which supports the magnetic needle. N and P the mercury cups in which the ends of the coils terminate. For other information, (see *Gold Leaf, Ritchie, &c.*)

GALVANOMETER, Differential. (See *Differential.*)

GAMBOGE. A gum resin, the produce of the *garcinia gambogii*, a large tree indigenous to India, Ceylon, Siam, Cochinchina, and Cambodia. It is of a fine yellow color, when diffused in water, and as such is much employed by painters in water colors. It is also used to stain wood in imitation of box and also marble; and as a coloring ingredient in lacquers and yellow varnishes.

GARGOYLE. A projecting water-spout, attached to old buildings, often grotesquely carved and ornamented.

GARLAND. A band of ornamental work around the top of a tower, &c.; also a circlet or continued wreath of flowers.

GARNET. A gem of a dark red color, of which there are two kinds; the precious garnet and the common garnet. The garnets of Peru are most highly valued. The common garnet is often of a brownish green color, and used by lapidaries as a polishing powder.

GARNET'S FRICTION ROLLERS. (See *Friction Roller.*)

GAS. The name of every permanently-elastic æriform substance. Gas is distinguished from steam or vapour by this circumstance, that vapours are raised from all fluids by heat, and are again condensed by cold into the same fluid form; but gases are obtained from the substances containing them only by chemical decomposition, whether this be spontaneous or artificial. They are either not condensable, or only so when submitted to an excessive pressure or degree of cold. Four of the gases are simple substances: oxygen, hydrogen, azote, and chlorine. The rest are more or less compound, as carbonic acid gas is a compound of oxygen and carbon; sulphurous gas of sulphur and oxygen, &c. Gases are mostly colorless; nitrous acid gas, however, is red; chlorine and its prot and deutoxyde are of a yellowish green; the hydrochloric, hydriodic, fluoboric, and flno-silicic produce white fumes in the air, and iodine violet-colored fumes when heated. The gases which are inflammable are hydrogen, and all its compounds; carbonous oxyde, and cyanogen. Those which more or less support combustion are oxygen, protoxide of azote, chlorine, and its oxydes.

Some gases are destitute of smell; others have an odour which is insupportable, and often characteristic. In properties numerous of the gases are acid; some neutral; two alkaline.

GAS Coal, Oil, and Rosin. The carburated hydrogen extracted from bituminous, fatty, or resinous substances, and which is so extensively employed for purposes of illumination; each kind differing very slightly from its other, and having different names merely on account of the material employed. The manufacture of coal gas may be stated as follows:—Any kind of coal which contains much bitumen is put into a retort; several retorts, about three parts filled, are placed in a furnace, and a strong fire kept up around them. Each retort is furnished with a small pipe, to convey into a larger pipe the impure gas which the coals in the retorts give off. This pipe conveys it into a cistern of water, where the tar and the grosser impurities are retained. The gas passes to the purifying vessel, which is filled with lime water, or rather with lime so mixed with water as to form a cream-like fluid, called therefore cream of lime. From this vessel it passes to a gasometer, where it is stored up till wanted for use, when it has to pass through the hydraulic valve, the gas governor, or where this is not used, the gas regulating valve, the main, the branch pipes, and burner; the gasmeter when used being placed near to the burner, if for registering individual consumption; or near the gasometer, if the whole quantity used is to be ascertained.

When gas is made from oil, the retorts are filled with broken bricks, coke, or other refractory substances; which becoming red hot, the oil is allowed continually to trickle into them, when it becomes decomposed. Gas of similar properties may be made from peat, wood, dry vegetables, saw-dust, &c.; though being contaminated with much carbonic acid, such gas requires greater care in its purification.

GAS, Portable. Coal gas, which after its manufacture, is compressed by a condensing or force pump into strong vessels prepared to receive it. These vessels being portable, the gas may thus be used where required, at any distance from the gas works.

GAS APPARATUS, includes the furnaces, retorts, pipes, valves, purifying machine, lime machine, gasometers, gasmeters, governors, &c., used in the manufacture, the purifying, and the supply of gases, particularly of coal gas, as used for illumination.

GAS BOTTLE. (See *Gas Retort and Bottle.*)

GAS BURNER. The jet or contrivance fixed to the end of a gas pipe for the purpose of separating the flame, or in other words for the division of the stream of gas into minuter streams, that its light may be more

diffused. Some of the more usual burners and their mode of diffusing the light will be seen annexed.

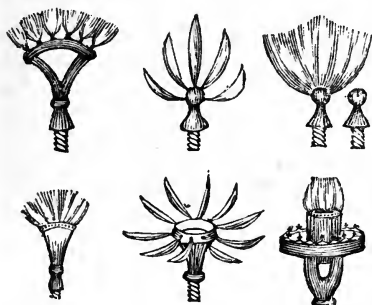

GAS GOVERNOR. A kind of gasmeter, adopted in gas works, for equalizing the pressure of gas previous to its issuing from the gasometer for the supply of light, as well as the inequalities arising from putting out the lights at different periods of the night.

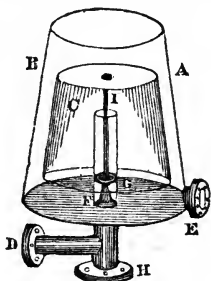

The cut shows the instrument in section. A B exhibits the outer case. C an inner case, made in the form of a small gasometer. D the pipe by which the gas enters; and E the pipe by which it passes out. The conical valve attached to the bottom of the spindle I rises and falls, so as to contract or enlarge the opening G, as the gasometer ascends or descends by the entrance or passing out of the gas; and H is a flanch or tube to which the instrument is affixed at the base.

GAS HOLDER. An instrument invented by Mr. Pepys, for holding such gases as are usually made the subject of experiment, or for the purposes of the chemist. It consists of two tin vessels; the lower one is to hold the gas, the upper one is used as a kind of pneumatic trough, to hold gas jars, or other apparatus. The lower vessel is closed on all sides, but has a hole covered with a screw on one side near the bottom; a stop-cock on the opposite side near the top; also two stop-cocks at the top, opening into the upper vessel, one of these being connected with a

long tin pipe, which reaches to near the bottom, inside. A glass tube is usually put

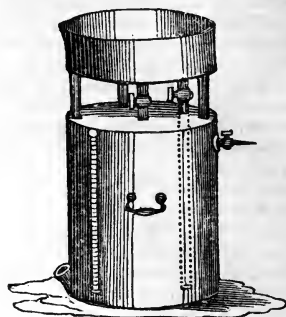

from one end to the other, and connected both at top and bottom with the vessel, by which the quantity of gas within may be ascertained. To use the apparatus; first, open all the cocks, then continue to pour water into the upper vessel till the lower one is filled; then close all the cocks and open the hole at the bottom, into which insert a tube, proceeding from the retort where the gas is making. When full, which will be known by inspection of the glass tube, close the lower hole. When the gas is to be used, open the cock which has the tube reaching downwards in the vessel, and pour water so as to fill the upper part; then upon turning either of the other cocks the gas will issue into bladders or jars placed to receive it, while the water will flow down and occupy its place.

GAS HYDRAULIC MAIN. The large pipe or tube into which the tubes leading from the various retorts are fixed, and which conveys the gas to the tar vessel or cistern in which it is cooled and purified from any undecomposed tar. It is called the hydraulic main because of its being partly filled with water. (See *Gas Retort*.)

GAS HYDRAULIC VALVE, or GAS HOLDER VALVE. The name given to the principal communication between the gasometer or gas holder, (for in the gas manufacture these terms are synonymous,) and the principal pipe leading to the mains. Suppose in the following cut, which is a section of the apparatus, that A is connected with the gasometer, and B the principal pipe. C is a round cup or cover, which may be raised up or let down upon the end of the pipe B, its edges in the latter case dipping into the water. It will be evident that when the cup C is raised up to the position in which it is represented, there will be a free passage for the gas from A to B; but when the cup is let down, the water will prevent all communication between the two pipes. The

valve may be fastened up or down by the stem E, as may be found necessary.

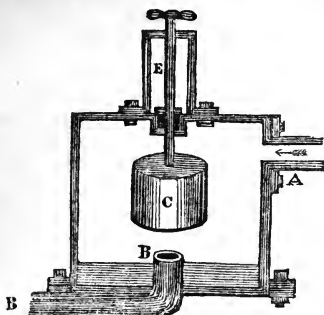

GAS JARS. Glass jars for the holding of the gases during the progress of experiments. Fluoric acid gas must be retained in silver or leaden vessels, as it immediately corrodes glass.

GAS LIGHT. The light afforded by the combustion of carburetted hydrogen gas, as procured by the distillation of coal, oil, tar, &c.; therefore called coal gas, oil gas, &c.

GAS LIQUOR. The liquid remaining in the various parts of the apparatus of gas works, after the manufacture of gas. It is water much contaminated with tar, ammonia, and sulphuretted hydrogen, as such it is very offensive in odour, and injurious to fish when suffered to escape into the ponds and rivers where they abound. It is also deleterious to vegetation. (See *Ammoniacal Liquor*.)

GAS MAIN. The principal pipes which conduct the gas from the gas works to the places where it is to be consumed.

GASMETER. An instrument for ascertaining the quantity of gas that passes through it, and thereby affords the consumer and supplier a correct means of ascertaining the consumption. The apparatus, as seen in section, is as follows:—

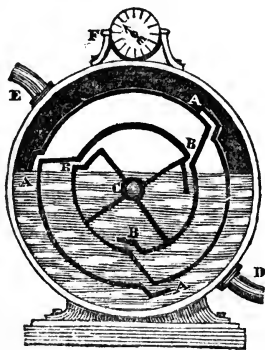

A A is a cylindrical box of tin, within which revolves a second cylinder, supported by the axis C, and consisting of two circular channels, concentric to each other. The larger or outer channel is divided into three compartments, by cross plates of tin, and opens into the outer vessel by means of valves, as represented; while three of the compartments of the inner vessel open into them in like manner, though the valves are at a different end. These valves are marked A A A and B B B. The action of the apparatus is as follows:—Suppose it to be filled to about an inch above the centre with water, and the gas to enter at the centre, the pipe which admits the gas being turned up a little, so as to be above the surface of the water; then the gas would fill the upper small compartment, and passing through the inner valve B would soon fill the left-hand large compartment, and as it fills, that side of the wheel would rise, until at length the gas would escape by the outer valve, which is now at the bottom of the case, but which would then be above the water. The gas, therefore, would be discharged by the pipe E to the burner, while the action would go on with the next division of the wheel. The number of revolutions of the wheel is registered by a train of wheel-work at the side, or dial at the top, and the capacity of the case being known, the quantity of gas consumed is easily ascertained.

GASOMETER. A case of iron, tin, copper, &c. so constructed as to hold gas, and at the same time to enable a person to ascertain the quantity collected. It is formed of two cases, one fitting loosely within the other; the outer one being open at the top, the inner one open at the bottom. The outer case ought to have a cock near the bottom, with a pipe attached to it, which extends half way across the bottom, and up the middle. The inner case is supported by cords and counterpoise weights, and bears a graduated rod, passing through a hole made in a frame, connected with the outer vessel. The cock

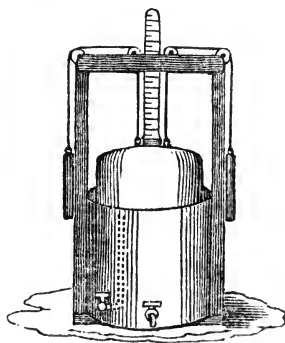

is opened, the whole instrument filled with water, the inner case forced down into the water; the pipe from the retort is attached to the cock, the gas ascends, and occupying the inner vessel, raises it a certain height, according to the quantity of gas introduced, and which is indicated by the gauge rod. The gas may be drawn off by the same cock, by another similarly situated, or by a cock at the top of the instrument.

GAS PURIFIER, PURIFYING MACHINE, or LIME MACHINE. A vessel into which the coal gas enters from the retorts, after passing through the vessel of cold water into which it first enters. The purifier is intended to deprive the impure gas of its sulphuretted hydrogen, and thus to take from it the bad smell which it has at first. There are numerous forms given to the instrument; the following is one of the simplest:—It represents a tin or iron circular vessel, closed at both ends. *BB* and *CC* are two shelves, which slope downwards, and pass round the vessel. *A* is a pipe, which extends very nearly to the bottom. *DD* are two circular shelves, put upon and fixed to the centre pipe *A*. *E* is a pipe to fill the vessel with liquid. *F* the pipe to convey away the purified gas. *G* and *H* cocks to empty the vessel when requisite. Nearly the whole of the purifier is filled with the cream of lime; that is, with lime and water so mixed together, as to be a cream-like substance. The impure gas enters by the centre pipe, passes round the lower shelf *D*, and then gradually upwards, according to the arrows, until it escapes by the pipe *F*.

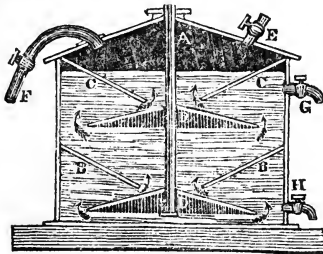

GAS REGISTER, is a simple instrument for indicating and registering the impurities of coal gas, and also the times when they occur.

The instrument consists of a circular card, which is connected with a time-piece, so as to turn round once in 24 hours. The card is divided into 3 circles, each of which is subdivided into 24 compartments, one for each hour of the night and day. The inner circle has the numbers of the hours printed upon it. The next circle is coated with any test for ammonia. The third or outer circle with a test for sulphuretted hydrogen. Opposite each of the two larger circles a fine jet

of gas is made to play, and of course, if contaminated, it will show the time and degree of that contamination by the change of color on the coated circles.

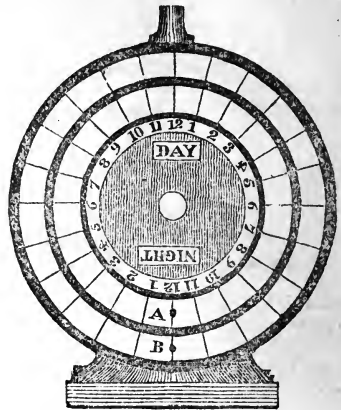

GAS REGULATING VALVE. A valve which is sometimes used instead of, or in addition to the gas governor. Suppose *B* in the following cut to be the section of the gas main. *A* is a plate of metal, which fits in a channel in the manner of a damper, or slides over the mouth of the pipe. This plate of metal is attached to a rod, which projects upwards as shown. The portion of circle which is black is for the passage of the gas. There is a gauge *C* connected with the gasometer, and another *D* connected with the main beyond the valve, so that the workman by raising or depressing the valve can regulate the pressure according to circumstances.

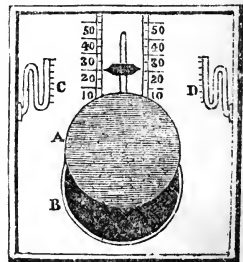

GAS RETORT. A vessel used for holding the coal or other material of which gas of any kind is to be made. Sometimes the common glass retort used by the chemist, is sufficient, as in the making of chlorine, fluorine, and other gases. For hydrogen it is usual to employ a peculiar-shaped bottle, (for the form of which see *Bottle*.) For oxygen an earthenware retort may be used, or else an iron

retort, formed like a common wine bottle. For the manufacture of coal gas, the retorts are of iron and formed cylindrical, or of some other elongated shape. The following cut, (No. 1,) shows a coal gas retort, the manner in which it is set in the furnace, and the pipe which conveys away the gas that arises. No. 2 shows a front view of several retorts, as set in the furnace. The pipe of each screwing to the same hydraulic main.

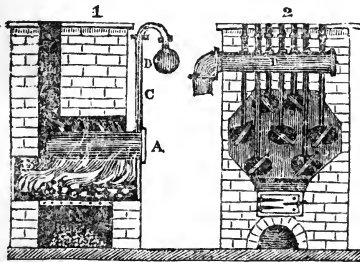

A is the retort. B the fire. C the gas pipe. D the hydraulic main, which leads the gas into the purifying vessels. A number of retorts put together in the same furnace is called a *bench* of retorts.

GAS TRANSFERFER. A small instrument invented by Mr. Pepys, for the conveyance of a small quantity of gas from one vessel to another. It consists of a glass tube, shaped as in the cut, both ends being open, and one of them drawn to a fine point. A tight piston and rod fits into the straight part of the tube. All the parts of the instrument below the piston are filled with mercury. To use the instrument, immerse it in a jar of gas, by passing the point upwards through the mercury in the mercurial trough. Draw up the piston, which will draw up the mercury also, and suffer the gas to enter the point of the transferfer. When enough gas has entered, depress the point below the surface of the mercury, and elevate the piston a very little to draw a globe of mercury into the fine orifice. When this has been done, the instrument may be taken out, and the gas it contains be carried where it may be required.

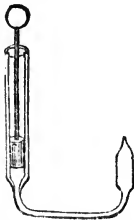

GAS WORKS. The manufactory at which coal gas is made for public purposes, together with the whole machinery and apparatus, are included under the term gas works.

GAUGE, is the name employed to denote various instruments used for measuring.

GAUGE, Air Pump. To the larger kinds of air pumps are usually fixed what is called a

barometer gauge, which is a tube of glass nearly 3 feet long, open at both ends, the upper end passing through the plate of the pump so as to be in connection with the receiver, the lower end dipping into a basin of mercury. As the air in the receiver becomes exhausted, the mercury is driven up the tube by the pressure of the atmosphere on the fluid in the basin, and according to the height of the column of mercury, so is the degree of exhaustion ascertained. To small air pumps a syphon gauge is used; when this is the case it is fixed on another plate distinct from that on which the receiver stands.

GAUGE, Barometer. (See *Air Pump Gauge*.)

GAUGE, Carpenter's. An instrument consisting of a shoulder and rod, which is made to slide backwards and forwards through its centre, there being a projecting point on the underside of the rod. It is used for scribing or marking, by means of the point, a line parallel to the edge of a board, along which the shoulder of the instrument is carried. The following is a superior instrument invented by Mr. Palmer, which is capable of dividing a board or other body into exactly two equal parts by a line drawn down it. It consists of two sides or shoulders, B and D, one of them having a screw C upon it. A is the arm or rod. E F is a jointed hinge of brass attached at either end to the shoulders. H is a screw, terminated by a sharp point beneath. If this instrument be placed on a board so that its two edges grasp the sides, and it be drawn along the point H, it will mark a line exactly intermediate between those sides.

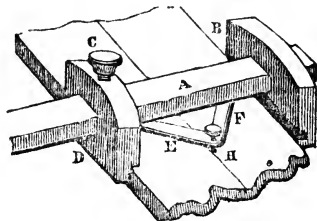

GAUGE COCKS. The cocks usually connected with the boilers of steam engines, for the purpose of ascertaining the height of water in the boilers; glass tubes are also sometimes employed for the same purpose, not only in steam boilers, but to *stills*, standing casks partly filled with a liquid, &c. Also, there is often attached to a steam engine boiler a bent glass tube, open at each end, and partly filled with mercury; this is called the steam gauge, and answers a double purpose. First, as a safety valve; and secondly, as an instrument whereby to ascertain the

pressure of the steam. Both these are represented in the following cut:—

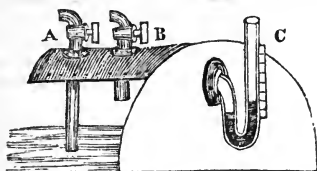

Besides these gauges, there are often others adapted to particular purposes, as the gauge, or graduated bent iron tube, attached to the condenser of an engine, which indicates the degree of condensation within.

GAUGE, Pressure. An instrument to determine the pressure exerted in hydrostatic or pneumatic machines, as the hydrostatic press, the air pump, steam engine, &c. When the pressure is very great, it is usual to measure it by the compression of a certain quantity of air contained in a tube of sufficient strength. The following is a gauge of this description:—It is a glass tube closed at one end, and with a ball near the other end, which fits to the apparatus or engine. The ball, under the ordinary pressure of the atmosphere, should be about three-quarters full of mercury, and the whole capacity of the ball may be about twice that of the tube beyond it. The tube is placed in a horizontal position, and graduated with numbers in geometrical progression. Thus, if the tube be full of air under ordinary pressure, the air will be compressed to No. 2 under a pressure of two atmospheres; to No. 4 with four atmospheres; and so on to the end. One-sixteenth of an inch is sufficient for the internal diameter of the tube, and it may be 6 or 8 feet long.



GAUGE, Rain. (See *Pluviometer*.)

GAUGE, Tide. (See *Tide*.)

GAUGE OF WAY, or RAILWAY GAUGE.

The width in the clear between the top flanches or rounded rims of the rails. The gauge of way generally employed, and that adopted on the London and Birmingham, Grand Junction, and other great lines of railway, is 4 feet 8½ inches; but it is made 7 feet on the Great Western.

GAUGE POINT OF A SOLID, is used to denote the diameter of that circle, or the diagonal of that square, whose area is expressed by the same number as is equal to the number of cubic inches in the solid. Thus, 18.79 being nearly the diameter of a circle whose area is 277.274; this is called the circular gauge point of the gallon, which

contains that number of cubic inches; and 16.6515 is the square gauge point of the gallon—this last number being multiplied by itself, forming 277.274. Gauge points are marked on the gauge rule by certain letters or characters. Elliptical, conical, and prismatic vessels, have also gauge points adapted to them.

GAUGE, Syphon. A name given to any gauge which is made in the form of a syphon; that is, with two legs bent upon each other—such as that of the steam gauge, the condenser gauge, &c.

GAUGING. The art or act of measuring the capacities of all kinds of vessels, and thence ascertaining the quantity of liquor which they contain.

GAUGING, or DIAGONAL ROD, is a rod or rule for determining the contents of casks, by measuring the diagonal only; viz. the diagonal from the bung to the extremity of the opposite stave, next the head. It is a square rod, having 4 faces or sides, being usually 4 feet long, and folding together by means of joints. Upon one face of the rule is a scale of inches; upon the opposite face is a scale of gallons. To use the rule:—Unfold it, and put it into the bung-hole; inserting it so as to take as long a line as possible with it within the cask. Note the inches and parts up to the middle of the bung; then draw out the rod, and look for the same inches and parts on the opposite face of it, and annexed to them are found the contents in gallons.

GAUGING RULE, is a sliding rule, particularly adapted to the purposes of gauging. It is a square rule, about 12 inches long, made of box wood; of four faces or sides, which are furnished with sliding pieces, running in grooves. The lines upon them are mostly logarithmic ones or distances which are proportional to the logarithms of the numbers placed at their ends.

GAUZE. A thin transparent muslin.

GAUZE WIRE CLOTH, or WIRE GAUZE.

A kind of open cloth, made of copper, brass, or iron wire, of different degrees of fineness; used for the covering of meat safes, for wire blinds, sieves, safety lamps, &c.

GAVEL. (See *Gable*.)

GAZOLYTA, or GAZOLYTES. A name given by Berzelius to such simple gases as are permanently elastic. These are oxygen, nitrogen, and hydrogen.

GEARING, or GEAR. Any series of large wheels working into each other. According to the position of the teeth of the wheels, or the purpose which the whole is intended to serve, so different names are added; thus we say, mill gearing, crane gearing, crown, bevelled, spur gearing, &c. If the series be of small wheels, the whole is called a movement; thus we say a clock movement, and not clock gearing.

GELATIN, or GELATINE. An animal substance, soluble in hot water, capable of assuming a well-known elastic or tremulous consistence by cooling when the water is not too abundant, and liquifiable again by increasing its temperature. This last property distinguishes it from albumen, which becomes consistent by heat. It is precipitated in an insoluble form by tannin. Glue and isinglass are examples of gelatin.

GEM. A jewel; a precious stone of any kind. The principal gems are the diamond, ruby, sapphire, emerald, chrysolite, hyacinth, tourmalin, opal, cornelian, onyx, topaz, turquoise, beryl, amethyst, blood stone, calcedony, jasper, garnet, cat's-eye, agate, &c.

GEM, Artificial. A kind of glass, so dense and hard as to refract the rays of light in the same manner as the precious stones, such glass being colorless when intended to imitate the diamond, or of appropriate colors when intended to represent other gems. (See *Paste.*)

GEM CUTTING. (See *Lapidary.*)

GEMINI. One of the northern zodiacal constellations, denoted by the character II.

GENERANT. That which is generated or supposed to be generated, by the motion of any point, line, or figure; for example, a circle which revolves rapidly on any diameter, generates a sphere; a line moved steadily along forms a surface. The circle and line are therefore generants.

GENERATED. In mathematics, formed or occasioned by motion, as a line is generated by a point; a solid by a surface; and so on. In the fluxional analysis all kinds of quantities are supposed to be generated by the motion of other quantities.

GENTIANIN. The peculiar principle of gentian.

GEOCENTRIC. Having the earth for a centre, as the moon. The planets moving round the sun as a centre are not geocentric, yet we speak of their geocentric places, latitudes, longitudes, &c., meaning thereby as they appear when viewed from the earth's centre.

GEODES. A kind of ætites, the hollow of which, instead of a nodule, contains only loose earth, and is commonly lined with crystals.

GEODESIA. That part of geometry and trigonometry which applies to the measuring of whole countries or very large tracts of land, or to the admeasurement of a degree of the meridian. Originally the term geodesia was considered as synonymous with land surveying.

GEOGNOSEY. Synonymous with geology.

GEOGRAPHY. The science which describes the surface of the earth, and in its more extended sense of its inhabitants also. It is divided into *physical* geography, which explains the cause and result of the earth's motions as a planet, and the effect produced on

its surface by the influence of the other heavenly bodies, such as the tides, seasons, currents, winds, its shape, &c.; *descriptive*, which gives an account of the climate, aspect, surface, appearance, and natural boundaries of different parts of the earth's surface. *Political* geography treats of the inhabitants, their institutions, languages, arts, customs, civilization, relative importance, religion, artificial boundaries, produce of countries, &c.

GEOLOGY. That part of natural philosophy which explains the structure and formation of the earth beneath the surface, as to its rocks, soils, minerals, &c.; searching into those different changes which have taken place in it in these respects, as well as the causes which have modified, and are now modifying the surface and crust beneath, such as volcanoes, currents, atmospheric phenomena, the agency of man, &c.

GEOMETRY. The science which explains the proportions, properties, and measurement of lines and surfaces. Geometry is divided into several parts; as *elementary*, which describes right lines, figures, and the properties of the circle; the propositions of which part is called *theoretic*, when any thing is to be *proved*; and *practical* when any thing is to be *done*. There is also the geometry of the compass, which is a part of the science, the practice of which is entirely performed by the aid of the compasses only. *Descriptive* geometry is a name given to that part of practical geometry which ascertains the inclination and particular form of the lines produced by curved surfaces cutting each other; as for example in groined and vaulted ceilings, &c., the *higher* or *transcendental* geometry is that which treats of the higher order of curves and problems.

GEOMETRICAL. Any thing relating to the science of geometry.

GEOMETRICAL ELEVATION. In architecture, a design for any part of a building drawn according to the rules of geometry, as opposed to the *perspective* or *natural* elevation. If of sufficient size to guide the working builder, it is called the *working* plan or drawing.

GEOMETRICAL FOCUS. (See *Focus.*)

GEOMETRICAL PACE. A measure of 5 feet.

GEOMETRICAL PLANE. In perspective, the same as ground plane. (See *Ground Plane.*)

GEOMETRICAL PROGRESSION AND PROPORTION. A series of numbers is said to be in geometrical progression when they have a common ratio or multiplier: thus, multiply 1 by 2, and the number produced by 2 again, and the second result by 2, the numbers resulting will consequently be in geometrical progression. The series will, of course, be 1, 2, 4, 8, 16, 32.

GEOMETRICAL SOLUTION. That result which is obtained from the simple principles of geometry.

GEOMETRICAL STAIRCASE. A staircase is so called when the stairs are supported only by being inserted into the wall at one end, with a continued range of ballisters at the other.

GEORGIUM SIDUS. (See *Herschel*.)

GERMINATION. The vital development of a seed when it first begins to grow.

GIBBET. That part of a crane which sustains the weight of goods.

GIBBOUS, generally denotes a convexity or protuberance. The moon is called gibbous when in her second and third quarter, being then protuberant or convex on both sides, and not a crescent as in the other two quarters.

GIG WHEEL. A mill in which the nap of woollen cloth is raised by the application of teasels.

GILDING. The art of laying gold on any surface by way of ornament. The art of gilding is performed either upon metals, or upon wood, leather, parchment, or paper. There are three distinct methods in general practice, namely, *wash* or *water gilding*, in which the gold is first mixed with mercury, then this amalgam rubbed over the article, and afterwards the mercury driven off by heat, when the gold remains; this method is only applicable to metals. *Leaf gilding*, either burnished, or in oil, is performed by cementing leaves of gold upon the work, either by size, or an oily varnish, called gold size. *Japanner's gilding*, in which gold dust or powder is used instead of gold leaf.

GILDING METAL. An alloy composed of 4 parts of copper, 1 part of Bristol old brass, and 14 ounces of tin, to every pound of copper. This alloy takes a fine polish, and as such is much used for common jewellery.

GIMBOLS. Brass rings, by which a compass box is suspended, in order that it may have freedom of motion, so as to swing easily in every position of the ship, and thus to preserve itself horizontally, when all around is agitated by the pitching and tossing of the vessel. They are applied also to numerous pieces of machinery, and will be understood by the following cut; the one gimbol allowing motion in one direction, and the other gimbol allowing it in the opposite.

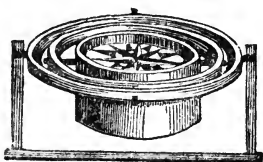

GIN. A jack, crane, pile engine, or any other machine used for raising great weights, is called a gin.

GINNING. The operation by which the filaments of cotton are separated from the seeds previous to the cotton being manufactured.

GIRDER. The main beam of a floor.

GIRDLE. A small circular band around the shaft of a column.

GIRT. The circumference of any thing, as the girt of a column, of a tree, &c. Girt is also used as synonymous with fillet.

GIVEN. A word used by geometers to denote any thing which is known. Thus, if a magnitude be known it is said to be a *given* magnitude.

GLAIRE. The white of eggs beaten up with water until it assumes a varnish-like consistence; is used for many purposes in the arts. As for example, to communicate a polish to kid leather shoes; to the covers of books; and often as a varnish for pictures: in which latter case it is advisable to add a small quantity of white sugar. It is laid on with a sponge.

GLACIAL. Appearing like ice.

GLACIAL ACETIC ACID, is this acid when it exists in a crystalline state, as it does when pure, united to an exact quantity of water, and subjected to cold.

GLACIAL PHOSPHORIC ACID, is the phosphoric acid mixed with a certain definite proportion of lime. When bones are dissolved in sulphuric acid and water, the result is two compounds; one a sediment of sulphate of lime, the other a transparent liquid. If this last be evaporated, it yields a second sediment of the quadriphosphate of lime, in the state of a white powder. Upon placing this in a crucible, it fuses into glassy scales, called glacial phosphoric acid, or glass of phosphorus. It is this substance from which phosphorus is made.

GLACIAL SULPHURIC ACID. When sulphuric acid is procured by the distillation of green vitriol, it is frequently observed that a portion concretes into a white mass of radiating crystals. This has been called glacial or fuming sulphuric acid, and is supposed to be the acid in an anhydrous state, or without water.

GLACIS. An insensible slope or declivity.

GLANCE COAL. Anthracite, (which see.)

GLANCE COBALT. A sulpho-arseniuret of cobalt; an ore of cobalt, found in Funaberg, in Sweden.

GLAND. A contrivance for engaging and disengaging machinery, moved by belts or bands.

A, B, are two spindles, one of which is intended to turn the other. Upon one is fastened a pulley C, which fits on to a part of the spindle B, the part where it fits being

cut square. The pulley C may, by means of a handle, be moved backwards and forwards, and it has upon it two studs or projecting pieces D, E. Upon the other spindle

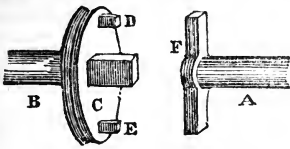

is the gland F, which is merely a strong cross piece either of wood or metal. As soon as the pulley is moved towards it, the gland takes hold of the projecting pieces, and is, with its spindle, thereby turned round equally with the other spindle.

GLASS. An artificial transparent substance, made by fusing various salts and metallic oxides with silicious earths. There are several distinct species of glass at present manufactured. *Flint glass*, which is composed of purified white sand, or else flints calcined and powdered 100 parts; litharge or red lead 60 parts; pearlash 30 parts. *Plate glass*.—300 lbs. of fine sand; 200 lbs. of soda; 30 lbs. of lime; 2 lbs. of magnesia; 3 oz. of cobalt azure; 300 lbs. of fragments of good glass. *Crown, or best window glass*.—300 parts of soda; 300 parts of fine sand; 33 parts of lime; 250 fragments of glass. *Green window, or broad glass*.—11 lbs. of dry Glauber salt; 10 lbs. of soda; half a bushel of soap makers' waste; 50 lbs. of sand; 22 lbs. of glass pot skimmings; 1 cwt. of broken green glass. *Bottle glass*.—White sand 100 parts; kelp, from 30 to 40 parts; lixiviated wood ashes, from 160 to 170 parts; fresh wood ashes, from 130 to 140 parts; potters' clay, from 80 to 100 parts; cullet or broken glass 100 parts. *Glass for imitating gems.* (See *Pastes*.)

GLASS ANNEALING FURNACE, is an exceedingly long semi-cylindrical oven, with one, two, or more large iron shelves, which extend and present an even surface from one end to the other. One extremity of the oven is heated to such a degree as nearly to make the glass red-hot; the other extremity is open to the air, consequently there is a gradual diminution of heat throughout. The glasses to be annealed are placed in iron trays: each tray as it is filled is put into the hot end, the workman making room for it by pushing the other trays along the shelf. Having just before taken away the last tray from the cool end of the shelf, the glass in its passage through the whole oven will be submitted to the requisite heating and cooling. The following is an internal view of the furnace, the open end being nearest the eye; the farther end being inclosed by doors

to confine the heat in that part, having also a furnace beneath it:—

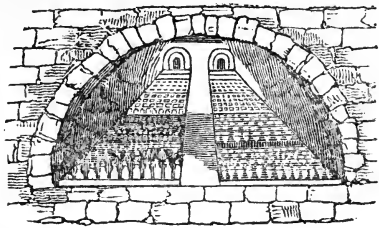

GLASS, Annealing of. Glass when it comes from the hands of the blower is exceedingly brittle, and unfit to bear sudden changes of temperature. To render it more tough it is placed in an oven, where it is first heated, and afterwards suffered to cool very gradually, by which gradual cooling, called annealing, the purpose is accomplished.

GLASS BLOWER'S FURNACE. The furnaces which are used in the manufacture of the various kinds of glass are constructed upon principles and in forms very different from other furnaces. The following cut exhibits one of the furnaces as employed in the manufacture and blowing of flint glass: it is a circular brick building, having a number of doors or apertures around its sides, each like the door of an oven. It is contracted into a dome at the top, with a small chimney above. Sometimes the fuel is cast into the chimney; at others there are fire-places in the story beneath. To each door there is a glass pot, or crucible, full of the melted metal, and a workman belongs to each of these pots, so that the furnace affords materials to as many workmen as there are openings in the side; these openings may be six, eight, or more in number. The whole is of course lined with fire brick.

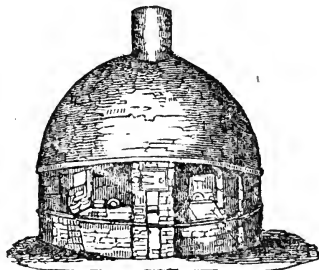

GLASS BLOWING. The art of converting melted glass into the form requisite for the various utensils made from it. It is performed by the workman taking in hand a long hol-

low tube of iron, called a blow-pipe; dipping this into the glass pot, it will take up a portion of the melted glass, or *metal*, as it is called by the workmen: then being withdrawn from the furnace, with the *metal* attached to it, the workman blows into the opposite end of the tube; the metal yields to the impulse of the breath, swells out like a bladder would under similar circumstances, and becomes a round hollow ball, which the workman fashions by rolling, pressing, and bending, while in a fluid state, into any required shape or size.

GLASS, Colored. In colored glass, the whole body of the material is tinged throughout by means of some coloring ingredient uniformly diffused through, or dissolved in the substance of the glass. The following are the substances used at the glass houses:—A *blue* color is given by oxyde of cobalt. *Green* by the oxyde of iron or of copper. *Violet* by the oxyde of manganese. *Red* by a mixture of the peroxyde of iron and of copper. *Purple* by the purple oxyde of gold. *White* by the oxydes of arsenic and zinc. *Yellow* by the oxyde of silver. The coloring of glass in the manufacture is accomplished by adding to the melted glass in the glass pot a portion of the above ingredients.

GLASS CUTTING. The process by which glass may be cut or ground into numerous ornamental forms.

GLASS DROPS. (See *Rupert's Drops*.)

GLASS, Etching on. (See *Etching*.)

GLASS, Frosting of. The art by which glass is made to assume an opaque appearance. This effect may be produced in various ways. First, by grinding it with sand and water, by means of a large cork held in the hand. Second, by the same materials while the article is turning in a lathe. Third, by submitting it to the fumes of fluoric acid and water. Fourth, by washing over it some semi-transparent substance, either common paste, a solution of gum tragacanth, &c.

GLASS GALL. (See *Gall of Glass*.)

GLASS OF ANTIMONY. A brown glass-like substance, consisting of the protoxyde and sulphuret of antimony, and procured by roasting sulphuret of antimony over a slow fire till it emits no fumes, and then melting it in a brisk fire till it assumes the appearance of glass.

GLASS OF PHOSPHORUS. (See *Glacial Phosphoric Acid*.)

GLASS, Painting of, is of two kinds; in one the colors merely cover the surface, from which they may be afterwards removed, such as the painting of magic lantern sliders, and occasionally, the glass of windows. This process is as simple as coloring upon paper; in the commoner kinds of it colors are rarely placed upon each other; in the better pic-

tures the colors are blended according to the talent of the artist, the plate of glass upon which he paints being supported upon a frame with a strong light *behind* it, the effect being ascertained by looking through the glass. The colors used are all transparent, and must be mixed with poppy oil, mastic varnish, and turpentine, or the two latter menstrua. The following colors are appropriate for the purpose:—Prussian blue, verdigris, Indian yellow, the lakes, carmine, burnt sienna, umber, &c. The second method is by the aid of vitrifiable colors, (see *Glass Staining*,) which are burnt in, the outline being first sketched with turpentine, mixed with Indian ink, or umber.

GLASS POT. The crucible in which the materials of glass are melted and kept in the furnace. It differs from the common crucible or melting pot, in being covered over at the top and open on the side. Thus, the fuel is not liable to fall into it; and the side hole allows the workman to take out the materials more readily than he could otherwise do.

GLASS PROOFS. (See *Bologna Phials*.)

GLASS, Silvering of. (See *Silvering*.)

GLASS SOAP. The name given by the glass blower to the black oxyde of manganese.

GLASS, Soluble. A simple silicate of pot-ash or soda, which unites perfect solubility in boiling water to some of the general properties of common glass.

GLASS, Staining of, is the communicating to glass a certain tint or stain, by laying a properly prepared liquid upon the surface, and afterwards submitting the glass to such a degree of heat as to occasion the liquid to penetrate into the texture of it, thereby staining it of a certain color in such a manner that the stain cannot afterwards be removed. Glass may thus be wholly covered, or only partially, exhibiting therefore in the latter case various devices, or a picture. All the preparations for this art contain silver in some form or other. A *yellow* is produced by equal parts of carbonate of silver and yellow lake; lay it on thin. In *orange*, take pure silver, in powder, 1 part; lay it on thin. For *red*, take of antimonic silver, prepared by melting together 1 part of silver and 2 of crude antimony, and pulverising the mass, 1 part; colcothar 1 part; lay it on thick. *Green* is formed by copper, in powder, 1 oz.; black lead 1 oz.; and 4 oz. of white lead, all calcined together; and then adding saltpetre one-fourth part. *Azure*, *purple*, and *violet*, are prepared in a similar manner to green, omitting the copper. and in its stead using sulphur for azure; perig-neau for purple; and both these drugs for violet.

GLASS WORKER'S TABLE. A table fitted up with double bellows, blow-pipe, jet,

lamp, &c. for the use of those who manufacture small articles in glass, such as thermometers, test tubes, ornamental objects, &c. The materials used are glass rods and tubes, of different colors and sizes. The apparatus is merely intended to produce a steady and intense heat, that the glass tubes may be softened in a manner proper for the artist to bend and blow them into the required form.

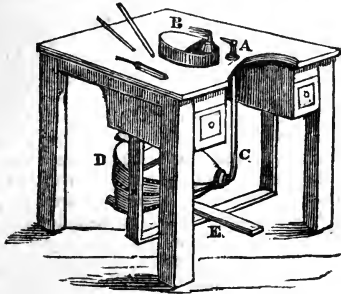

A in the cut is a jet, from which issues the current of air. B is the lamp, which has a long large wick; the flame from this is driven to a point by the agency of the current of air. C is a tube communicating between the jet A and bellows D. E is the treadle to work the bellows.

GLAUBER'S APPARATUS. Synonymous with Woolf's apparatus, (which see.)

GLAUBER SALT. Native sulphate of soda.

GLAZE. Glazes are either polishing or vitrifiable. The polishing glazes, and which are mostly attached to a lathe or revolving spindle, are made of round pieces of wood, covered with buff leather, then with glue, and finally with emery powder, putty powder, or other similar polishing ingredients. These being prepared are made to revolve in the manner of a grindstone, and the article to be glazed is held against the edge. Glazes for earthenware are of various kinds. Common salt affords a cheap glaze for ordinary articles. Another common glaze is 10 parts of litharge and 4 parts of ground flints. Those recommended for fine work are first, a compound formed by equal parts of lead and tin kept in fusion until completely oxydated. Second, calcined flint 8 parts; ground porcelain 15 parts; crystals of calcined gypsum 9 parts.

GLAZING has four distinct meanings. First, the process of placing the panes of glass between the frames of windows, doors, &c., where it is to remain. Second, the art of communicating a glass-like appearance to an article; for example, pottery and china-ware, by means of a substance, called a *glaze*. Third, the polishing of a metallic, wooden, or stone surface, by the friction against it of a polishing powder. Fourth, *glazing* in the arts signifies the overlaying or

finishing of pictures in oil with brilliant and pellucid colors, intended to soften the painting, and by blending the colors before laid on to give it tone and harmony.

GLADINE. A name given occasionally to the gluten of wheat.

GLIMMER. A name sometimes given to micaceous earths.

GLOBE. Any round solid body. It is supposed to be formed, or is such a body as would be formed by putting a circle in rapid motion around one of its diameters; hence synonymous with sphere. When we speak of *the globe*, the earth or world is understood to be indicated.

GLOBE, Artificial. A sphere made of metal, stone, paper, &c. The term, however, is mostly applied to those globes which are made of paste-board, and which have upon their surfaces representations of the earth or heavens, designed to illustrate certain parts of the sciences of astronomy and geography. The globe adapted to the former science being called the *celestial*, and the latter the *terrestrial globe*.



The fundamental parts of these instruments which are common to both are, first, the two poles whereon the globe is supported, representing those of the world; second, the brazen meridian, which is divided into degrees, and passes through the poles; third, the wooden horizon, whose upper side represents the real horizon, and is divided into several circles, (see *Horizon*;) fourth, a brass quadrant of altitude, (see *Altitude*;) fifth, two hour circles, one moving round each pole as a centre, and divided into twice 12 hours, to indicate those of the day and night. The best globes have also a magnetic compass attached to the frame. Upon the surface of

the globes are depicted the lines of latitude and longitude, the equator, ecliptic, tropics, and polar circles. On one globe, in addition to these, are the various countries, seas, &c. of the world; and on the other, the stars in their relative positions.

GLOBULAR. Relating to or partaking of the nature of a globe.

GLOBULES. Small globes; such for example as minute drops of quicksilver.

GLOWING LIGHT, or LAMP. A light is so called when arising from a combustion of such a nature as that no emission of an inflammable gas, consequently no flame arises; such as the light of charcoal, of a stick of phosphorus, of platinum heated by hydrogen, &c.

GLUCINA. An earth of peculiar character, discovered by Vauquelin to exist in the gem aqua marina, and afterwards in the emerald. Its name is derived from its distinguishing character, of forming with acids salts which are sweet to the taste. Glucina is a white soft powder, light, insipid, and adhering to the tongue; remains unaltered by heat; does not change vegetable blue colors, is insoluble in water, and dissolved by potass, soda, and carbonate of ammonia, but not by pure ammonia.

GLUCINUM. The supposed metallic base of the earth glucina.

GLUE. A dried jelly, made from the parings of hides and other offal, by boiling them in water, straining through a wicker basket, suffering the impurities to subside, and then boiling a second time. In this state the glue is poured into flat frames or moulds; when congealed it is cut into small pieces, and afterwards dried in a coarse net. Shreds or parings of vellum, parchment, or white leather, make a clear and almost colorless glue.

GLUTEN. If wheat flour be made into a paste and washed in a large quantity of water, it is separated into three distinct substances; a mucilaginous saccharine matter, which is readily dissolved in the liquor, and may be easily separated from it by evaporation; starch which is suspended in the fluid, and subsides to the bottom by repose; and *gluten*, which remains afterwards; it is tenacious, very ductile, somewhat elastic, and of a brown grey color. From the flour of barley, rye, or oats, no gluten can be obtained, as from that of wheat.

GLYCERINE, or the SWEET PRINCIPLE. A compound discovered by Scheele in soaps and soap liquors. It may be made as follows:—Saturate the alkaline mother liquor, from which soap has congealed, by dilute sulphuric acid, adding a little carbonate of baryta to remove any excess of acid; filter, evaporate to the consistency of thin syrup, to which add alcohol, which dissolves the glycerine, and leaves the alkaline sulphate.

GLYCERIZIN. A kind of sugar extracted from the liquorice root.

GLYCIUM. Synonymous with glucinum.

GLYPHIC. In sculpture, the art of engraving figures, &c., on stones and other hard substances.

GLYPTOGRAPHY. The knowledge of engraved gems.

GLYPHS. The channels in a Doric frieze. (See *Triglyphs*.)

GNOMON. In dialling, is the style, pin, or cock of a dial, the shadow of which points out the hours. This is always supposed to represent the axis of the earth, to which it is therefore parallel.

GNOMON. In geometry, is a space included between the lines, forming two similar parallelograms, of which the smaller is inscribed within the larger, so as to have one angle in each common to both. The two parallelograms $ABCD$ and $AGFE$ in the following cut will be in this condition, the angle A being common. The gnomon, therefore, will be all the space outside the smaller parallelogram $AGFE$. So also three other gnomons may be made out of the same figure, taking out each time the corner piece, as is seen below

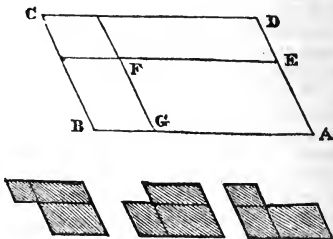

GNOMONIC PROJECTION. A representation of one of the hemispheres of the earth on a flat surface, the pole being the centre of that surface. It shows the earth as it would

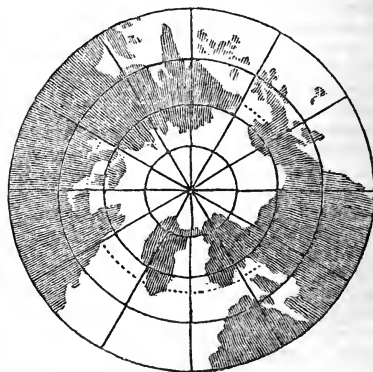

appear if looked down upon from the pole itself; the meridians in this projection are consequently straight lines. The annexed is a gnomonic representation of a part of the earth's surface around the north pole.

GNOMONICS. The art of dialling. (See *Dialling*.)

GÖBEL'S PYROPHORUS. The tartrate of lead heated to a dull red in a glass tube, until it acquires a brown color; when cool, and it is dropped from the tube into the air, it immediately inflames.

GODROON, or GADROON. A kind of inverted fluting, beading, or cabling, with which various architectural members and ornaments are decorated.

GOLA, or GYLA. Synonymous with ogee, a kind of moulding.

GOLD. A yellow metal, which is soft, very tough, ductile, and malleable; unalterable and fixed, whether exposed to the atmosphere or to the strongest heat of furnaces. A heat equal to about 1300° of Fahrenheit's thermometer is required to melt it. Its color, when melted, is of a bluish green. No acid acts upon gold, it being soluble only in the mixture of the nitric and hydrochloric acids, called aqua regia; and in the mixture of chromic and hydrochloric acids. There is but one oxyde, which is of a purple color, and may be obtained by sending an electric shock through gold leaf inclosed by two pieces of glass. Gold unites with most other metals, and with sulphur, ammonia, &c.

GOLD MANHEIM, or SIMILOR, is an alloy composed of 3½ ounces of copper; 1½ ounces of brass; and 15 grains of pure tin.

GOLD-BEATER'S SKIN. An extremely fine membrane made of the intestines of animals, principally sheep. It is used by gold-beaters to interlay with the leaves of gold which are under the process of hammering. It has the peculiar property of not altering its dimensions, even under the long-continued beating it receives.

GOLD COIN of England at the present time consists of the five pound piece, the two pound, the sovereign, and the half-sovereign, the two former being scarce. Their composition is not pure gold, but composed of gold 11 parts, and copper 1 part.

GOLDEN NUMBER. A number showing which year of the lunar cycle any given year is. To find the golden number, add one to the given year, and divide the sum by 19; what remains will be the golden number, unless (0) remains, and then 19 is the golden number. (See *Epact and Cycle*.)

GOLDEN RULE. In arithmetic, the rule of proportion, called *golden*, from its extensive application.

GOLDEN VARNISH, is made of 16 ounces of boiled linseed oil; 8 ounces of Venice turpentine; and 5 ounces of Naples yellow.

Heat the oil with the turpentine, and mix the Naples yellow pulverised.

GOLD LEAF. Gold beaten between skins and membranes to a degree of extreme thinness. The best wrought gold is so thin that 1 grain covers 57 square inches; and 282,000 leaves are required to form a packet of an inch in height.

GOLD LEAF GALVANOSCOPE. The construction of the gold leaf galvanoscope is similar to the instrument of Mr. Bennet, (see *Bennet*,) except that the leaf of gold is single, and there is added a forceps to retain the lower end of the gold leaf, and complete the galvanic circuit. The slip of gold leaf B is freely suspended from the pin or forceps A, while the lower end is laid hold of by another pin or forceps C. The pin A is connected with the cup P, and the pin C with the cup N. The whole, except the cups, is inclosed in a cylindrical glass case, the middle of which is placed between the poles of a strong horse-shoe magnet D D, so that the gold leaf may be equally distant from them. When the current is made to pass along the gold leaf, it will be attracted to the one pole or the other, according as the current is ascending or descending. The degree of attraction may be estimated by comparison with a line drawn perpendicularly along the glass tube which forms the cover.



GOLD SIZE. A thick tenacious kind of varnish which dries rather quickly. It is used by gilders to form the letters and other objects which are to be gilt, in order to make the gold leaf adhere to them; it is sometimes slightly mixed with a yellow coloring substance. There are many receipts, among which is the following:—Expose boiled linseed oil to a strong heat in a pan; when it emits a black smoke, set it on fire, and in a few minutes extinguish it by putting on a cover; then add some spirits of turpentine, till of a proper consistence when cold.

GOLD SOLDER. The alloy used for soldering gold articles is composed of 12 dwts. pure gold, 2 dwts. pure silver, and 4 dwts. copper.

GOLD THREAD, is a fibre of silk, covered with gold wire.

GOLD WIRE. That which is usually called so is merely silver wire gilt.

GONIOMETER. An instrument for measuring the angles of solid bodies, particularly the angles of crystals. The following is a simple form of the instrument:—

A A is a semi-circle of brass, graduated from 0 to 180°. B B is an arm, which connects the ends of the scale. C C is an arm, moveable around the centre. Any crystal

therefore put between the wider part of C and B will occasion the narrower part of C to fall

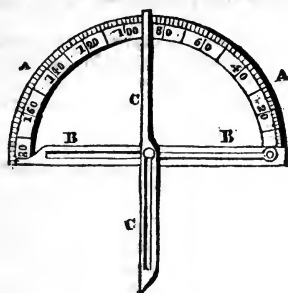

upon one of the marked divisions of the scale, which will therefore show the angular measurement.

GONIOMETRICAL LINES, are lines employed in measuring or determining the quantity of angles, such as sines, tangents, secants, &c.

GONIOMETRY. The art of measuring angles, either by calculation, or by means of instruments adapted to the purpose.

GORGE. Synonymous with cavetto.

GORGERIN. (See *Hypocrachelium*.)

GOTHIC. Any thing far removed from the manner and proportions of the antique.

GOTHIC ARCHITECTURE. A style of building of considerable strength, majesty, richness, and beauty, brought originally from the North by the Goths into Germany, and hence by the Saxons into England. The style thus introduced was and is called the Saxon Gothic, or simply the *Saxon* style. Afterwards the Normans introduced their own modification of Gothic architecture, hence called the *Norman* style. English, French, and German talent being added, the once rude and heavy Gothic became more richly decorative, and more finely proportioned. The art advanced in successive periods, through the varieties which have been since called, the *early English*, the *lancet-arched*, the *decorated*, and the *perpendicular* or *Tudor* style, when Gothic architecture was practised in all its lavish beauties and sublime proportions.

GOUGE. A hollow chisel, for cutting holes, channels, grooves, &c., in wood or stone.

GOULARD'S EXTRACT, or GOULARD WATER. A solution of the subacetate of lead, (sugar of lead.)

GOULD'S MICROSCOPE. A compact, convenient, and powerful instrument, adapted equally as a travelling and table instrument. The whole fits into a mahogany box, when put away, and which box forms a stand for it when in use.

In the centre of the lid of the box screws the upright square stem A. This has upon

one side of it a rack movement, in which works the screw B, intended to raise or de-

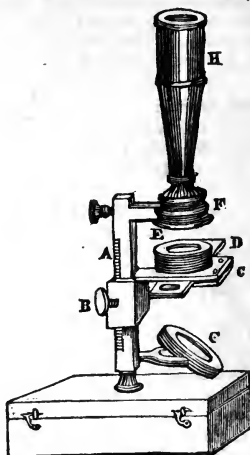

press the stage C, as occasion requires. C consists of two plates of brass, held together by a spring; between these plates the object slider D is placed. E is an arm at right angles to A; it is attached and confined by the screw at the end of it, in A. F must be supposed to represent three lenses or magnifiers, screwed together; the focus of each being such that they act in unison together. G is a reflector, to cast the light upwards through the object to the eye. H is the main tube, which bears the eye lens at one end, and screws upon one of the object lenses at the other.

When the instrument is in use, the focus is adjusted by moving the screw B, and the degree of magnifying power is according to the lenses which are screwed on to the bottom of H. Thus, if one lens obtain an increase of 10, two lenses may obtain a power of 100, and three lenses of 1000. Let it be always remarked, that the more lenses the more obscure will be the image.

GOVERNOR, Steam Engine; or Conical Pendulum. This instrument is calculated to equalize the rapidity of motion of the machine to which it is attached: it consists of two balls, suspended on wires, jointed at the top, and connected with two rods below, which rods are connected with a socket, which slides up and down the axis that supports the whole. The instrument is turned by a wheel or cord attached to it. The faster it turns the higher the balls are separated by their centrifugal force, and consequently the higher the lower socket rises, and with it rises also a rod, which moving a valve in a distance admits more or less steam, and thus reduces or increases the motion.

A is the point at which the ball rods are fastened. E and B sockets on which they turn. C C the balls themselves. F the upright spindle. D D the joints of the lower levers of the balls. G and H the bevelled gear, which gives the governor its motion. J the lever which is raised, and which regulates the steam valve.

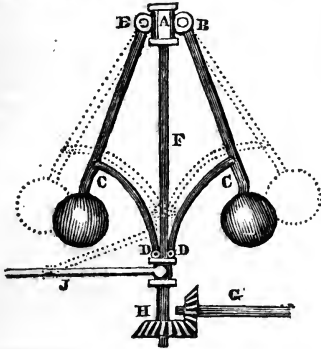

GOWT, or Go Out. In engineering, a sluice used in embankments against the sea, for letting out the land waters when the tide is out, and preventing the ingress of salt water.

GRADATION. A gradual blending of one tint into another, or in the arts a regular and equal disproportion of several things near to each other, or of different parts of the same object.

GRADIENT. A term indicative of the proportionate ascent or descent of the several planes upon a railway; thus, an inclined plane, 4 miles long, with a total fall of 36 feet, is described as having a gradient of 1 in 587, or 9 feet per mile.

GRADUATED. Any thing marked in degrees of equal parts, as distinguished from the division into inches or other certain and determinate measurements. Hence in graduating an instrument, the length of the degree is in proportion to the size of the instrument; but a measurement in inches, &c. has no reference to the length of the scale employed.

GRADUATION. The art of graduating or dividing.

GRAFTING TOOL. A kind of spade made very strong and much curved, used in digging canals; often called only a *tool*.

GRAHAM'S MERCURIAL PENDULUM. (See *Mercurial*.)

GRAIN. The smallest nominated weight; supposed to have derived its name from being the weight of an ordinary grain of barley. If an object weighs less than a grain, its weight is designated as a certain part of a grain, such as the eighth, quarter, &c.

GRAINER. The mixture obtained by infusing pigeons' dung in water; is used for giving flexibility to skins in the process of tanning, and is called the *grainer*.

GRAINING. The art of imitating the fancy woods and marbles by means of water or oil colors.

GRAIN TIN. (See *Tin*.)

GRANITE. A hard compact stone, much used in building, composed of separate and very large concretions rudely compacted. The white granite, with black spots, sometimes called moorstone, which is much used in the pavement of London, is a very firm, and though rude, yet beautifully variegated mass. Hard red granite, variegated with black and white, called oriental granite, and Devonshire granite, is valuable for its extreme hardness and beauty, and its capability of receiving high polish. The Aberdeen, Cornish, and Irish granites are particularly fine. It is considered by geologists as one of the primitive rocks, that is, one of the oldest formation, and forms the chief portion of all large mountains.

GRANULATION. The method of dividing metallic substances into grains or small particles, in order to facilitate their combination with other substances; and sometimes for the purpose of readily subdividing them by weight.

GRAPHIC MICROSCOPE. An instrument invented by Mr. Cornelius Varley, for the purpose of depicting the objects represented by the microscope. Its principle of action is that of reflection, as will be immediately seen by the following cuts of the microscope:—No. 1 shows the outward form. The object is placed on the stage. Light passing through it in the usual manner from the reflector beneath, its image is carried upwards till it strikes a plane mirror above; then passing along the tube, and through the lenses of it, the light is again intercepted by a second mirror, (this as well as the former being at an angle of 45° with the tube,) and cast down to a sheet of paper. The second mirror is formed like a prism, so that, as in the

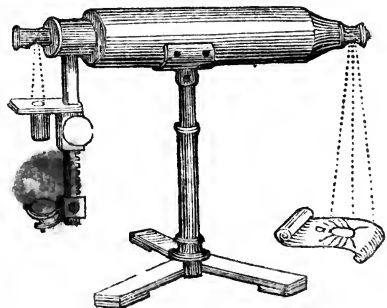

camera lucida, the eye is capable of looking across its edge, and seeing the object beneath, which may therefore be drawn by the aid of a pencil.

The second cut shows the glazing and internal structure of the instrument; the manner in which the light is reflected will be easily understood.

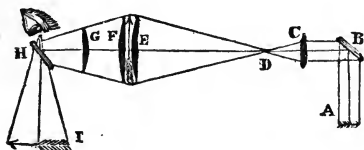

GRAPHITE. Black-lead.

GRAPHOMETER. A semi-circle graduated around its circumference, and by which angles may be measured. The common goniometer is one form of the instrument.

GRATICULATION. A term used by some writers for dividing a drawing into compartments or squares in order to be reduced.

GRAVING DOCK. (See *Dock*.)

GRAVITATION. The power or tendency of moving towards a centre, therefore called the centripetal force; it is this which constitutes the weight of bodies, and which keeps the earth and planets in their respective orbits, and chiefly in their globular shapes. It is also the cause of bodies falling to the earth. The power of ordinary gravity depends upon two causes. First, according to the size of a body multiplied into its specific gravity; that is, in proportion to the quantity of matter which a body positively contains. Second, the weights of bodies being equal, gravitation is stronger according to the square of the nearness of the bodies to each other; or as mathematicians usually say, inversely as the square of the distance. Thus, if one body be five times as heavy as another, the larger one will have five times the attractive force; but if one be twice as far off a third body, it will attract it with only one-fourth the power; if three times the distance, the power of gravitation will be one-ninth, and so on.

GRAVITY, Line of Direction of, is a straight line which passes through the centre of gravity of a body in a direction towards the centre of the earth. If this line pass beyond the base of the body, the body will fall.

GRAVITY, Specific, is the relative gravity of any body or substance, considered with regard to some other body which is assumed as a standard of comparison, which standard, by universal consent is rain water; this fluid not being subject to much variation from time, place, or other circumstance. One cubic foot of rain water weighs exactly 1000 (avoirdupois) English ounces; hence the relative weight of other bodies is easily referred

to this standard: for example, gold, when hammered, weighs 19362 ounces the cubic foot; it is therefore more than nineteen times heavier than water. The foot of cast iron weighs 7207 ounces; flint 2594; brick 2000; marble 2742; cows' milk 1032; whale oil 923; wax 897; oak 1170; poplar 383; atmospheric air $1\frac{1}{2}$; hydrogen gas one-tenth of an ounce the cubic foot.

GREAT CIRCLE. (See *Circle*.)

GREEK ARCHITECTURE. Such as was practiced by the Greeks. Its chief characteristic is the exact proportions of all its various parts, members, and ornaments, as known and explained by the names given to the Grecian orders of Doric, Ionic, and Corinthian. (See these terms.)

GREEK CROSS. (See *Cross*.)

GREEK FIRE. An inflammable composition of such great power of combustion as when once lighted not to be extinguished by any means, not even by water. The composition is now unknown, but asphaltum and a strong kind of gunpowder are supposed to have been its principal ingredients.

GREEK ORDERS. (See *Greek Architecture*.)

GREGOREAN TELESCOPE. A reflecting telescope, the internal construction of which is shown in the following sectional cut:—

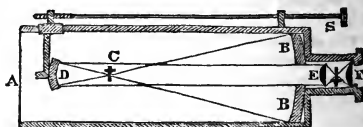

Rays of light from any distant object are supposed to approach from the end A, and passing along the tube of the telescope to strike against the speculum B B. Here they are reflected, come to a focus at C, and pass onwards till they strike the concave mirror D, from whence they are sent off parallel to the compound eye glasses E and F. The use of the screw S is to adjust the focus of the small lens.

GREEN. A color produced by the union of blue and yellow. In the Newtonian hypothesis of the composition of light: it is considered as a distinct color, forming one of the seven primitive colors.

GREEN SAND. A native submuriate of copper, found in Peru and Chili.

GREEN VERDITER, or MINERAL GREEN. A bulky hydrated dicarbonate of copper, obtained by precipitation from hot solutions of copper, by the carbonates of the fixed alkalis.

GREEN VITRIOL. The sulphate of iron.

GREEN EARTH. A frequent mineral in Scotland, England, Ireland, Iceland, Saxony, Hungary, &c. It is the *mountain green* of artists in water colors; the color is durable,

but not so bright as the pigments made from copper. The *green earth* of Verona is reckoned the best.

GRAVER. A tool used by the metal and wood engraver, chaser, &c. for the purpose of cutting the lines and forming the design, called therefore the engraving. Gravers are sometimes straight, and sometimes rather turned up at the point. They are made of a square or rectangular piece of steel, ground so that the face or cutting part resembles a lozenge. The following cut shows a straight graver, and the points of several others of different sizes:—

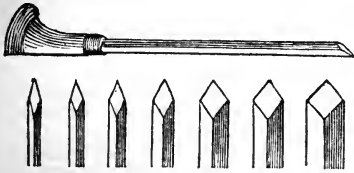

GRIDIRON PENDULUM. A pendulum so called from its peculiar shape. It is formed of five bars of metal, as represented, the small cross pieces fastening them together not being shown. The two outer bars, and also the centre bar to which the bob is attached are of steel, and the two intermediate bars are of an alloy of zinc and silver. Both series of bars expand by heat; the steel bars have therefore a tendency to lengthen the pendulum, but this is counteracted by the bars of zinc and silver drawing the pendulum up again by expanding upwards, as will be seen. The contrivance therefore compensates for changes of temperature. It is often called from this circumstance, and the name of the inventor, *Harrison's Compensation Pendulum*.

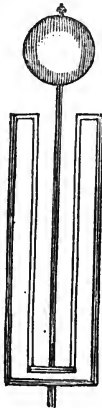

GRIFE, or BREAK. A pliable lever, which can be pressed against a wheel to retard or stop its motion by friction.

GRILLAGE. A term applied to the sleepers or cross beams supporting a platform, upon which some erections are carried up, as piers in the case of marshes or watery soils, whereby an equal bearing is given to the foundation.

GRIT STONE. A stone, consisting of particles of sand agglutinated together. Some of the species are used for grinding; others for sharpening edge tools; and others for filtering water.

GROIN. In engineering, is a wooden break-water, intended chiefly to retain the mud and sand thrown up by the tides, so as to gain land from the sea, or to restrain its inroads

GROINS. The angles which vaults make by their intersections.

GROINED ROOFS. Vaulted ceilings, supported by groins and ribs, intersecting each other.

GROOVE. A small, square, hollow channel, cut out of a board, flat stone, &c., either as an ornament, or to insert a panel, or other similar piece.

GROTESQUE. Distorted of figure; unnatural.

GROTTOESQUE. Artificial work, formed in imitation of grottoes or rock-work.

GROTTO. An artificial cavern or cave, decorated with rock-work, shells, &c., constructed for colness.

GROUND. The surface of any thing, particularly the surface of the earth. In painting, it signifies the first coats of color which are put up the canvass, previous to the figures being depicted upon it. In a finished picture it is the scenery around the principal objects, the part nearest to the eye being called the *foe-ground*, and the more distant parts the *bk-ground*. In sculpture it is the flat space at the back of bas or alto relief.

GROUND CILL. (See *Ground Sill*.)

GROUND LINE. In perspective, the intersection of the picture with the ground.

GROUND NICHE. A niche whose bottom is on the same level with the floor.

GROUND PLAN. The plan of a story of a house the same level with the surface of the ground, or elevated only a few steps before the floor.

GROUND PLOT. A piece of ground selected for being upon.

GROUND SILL, or PLATE. The lowest horizontal timber or course of stones on which the exterior walls of a building are constructed.

GROUND TABLE STONES. Now plinth.

GROUND-WORK. The same as foundation.

GROUPED COLUMNS, or PILASTERS. That which consist of more than two.

GROUT. A thin semi-fluid mortar, composed of quicklime, with a portion of fine sand which is prepared and poured into the irregular joints of masonry or brick-work. The process is called grouting.

ROVE'S GALVANIC BATTERY. A battery composed of any number (usually six,) of cells, each of which may be explained as follows:—First, is a common jelly pot; next inside this is a cylinder of zinc, without bottom; next is a cup of the same shape as the jelly pot, but narrower, and made of some porous substance, such as tobacco-pipe clay, common clay, &c. unglazed; inside of this is a slip of platinum. Outside of the porous vessel is poured dilute acid, or salt and water, while the porous vessel is filled with strong nitric acid. The zinc of one

cup is connected with the platinum of the next throughout the series. This battery is very powerful till the nitric acid is exhausted, which it will be in an hour or so.

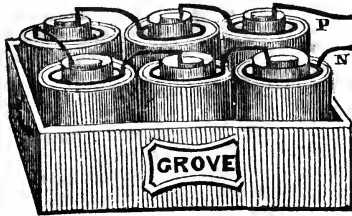

GUAIACUM. A gum resin, extracted from the wood of the guaiacum officinale, a large tree of the West Indies; the wood of which is often imported and known by the name of lignum vitæ. The gum is used occasionally in medicine, in rheumatic and other cases.

GUARDS. In engineering, upright pieces of wood, iron, or stone, fastened to the lock gates of a canal, the corners of street, and similar situations, to prevent the passage of barges in the one place, and waggon in the other, from injuring the part flush with, or near to the guard.

GUDGEON. The centre or pivot of a wheel.

GUILLOCHI. Ornaments used in Italian cornices, very similar, but larger than the braided ornament, and consisting of curved lines interlacing each other.

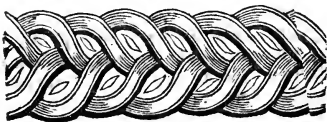

GUINEA AND FEATHER APPARATUS. A contrivance used in the illustration of mechanics, to prove that the air offers a considerable resistance to the falling of light bodies. A is a brass plate, fitting on to the top of a long open receiver. B is a stuffing box, through a hole in which the wire C moves round. E and F are two wires, screwing upon the under side of A, and having at the lower end of each a small flap, moveable on a hinge. One flap, H, is represented as hanging down;



the other flap, G, is supported at the free end by a semi-circular, or rather segmental flanch D, at the lower end of C. Suppose the two flaps are both up, and loaded with a guinea and a feather each; upon turning C round, one flap will soon be liberated, in consequence of a portion of D being cut off, which allows it to fall; and the guinea and feather being liberated at the same time, the guinea, being the heavier object, will reach the bottom of the receiver first. This being proved, exhaust the air from the receiver, and then let the other guinea and feather escape, when it will be seen that in consequence of the resistance of the air being taken away, the two objects will reach the bottom at the same moment.

GULA. (See *Cymatium*.)

GULLIES, A name applied in some places to the iron tram plates or rails, laid for the use of tram waggons.

GUM. The mucilage of vegetables; the principal gums are:— 1. The common gum obtained from the plum, cherry tree, &c. Gum *Arabic*, which flows naturally from the acacia of Egypt, Arabia, and elsewhere. Gum *Senegal*, a similar species, brought from Senegal and other parts of the coast of Africa; and gum *adragant*, *tragacanth*, or gum *dragon*, obtained from a small plant of the same name, growing in Syria.

GUM, British. (See *Dextrine*.)

GUM, Elastic. (See *Caoutchouc*.)

GUM RESINS. A class of substances possessing properties intermediate between the gums and resins. The principal are frankincense, scammony, asafoetida, aloes, gum ammoniac, and gamboge.

GUN-BARREL APPARATUS, for making Potassium, is thus described in "Brande's Chemistry." A sound and perfectly clean gun barrel is bent, as shown in the annexed cut:—

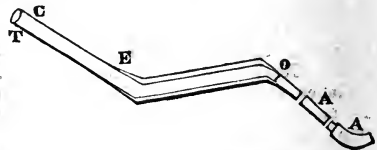

It is then covered with an infusible lute between the letters O and E, and the interior of the luted part is filled with clean iron turnings. Pieces of fused potassa are then loosely placed in the barrel between E and C. A A is a copper tube and small receiver, which are adapted to the extremity O, and to each other by grinding. The apparatus is next transferred to the furnace, (see following cut;) X and T representing two glass tubes dipping into mercury. The furnace is well supplied with air by a good double bellows entering at B, and a small wire basket is sus-

pended below the space E C. This part of the barrel is cautiously raised to a white heat, and the escape of air by the tube X shows that all is tight. Some charcoal is put in the end E of the cage G, which causes a portion of the potass to liquify and fall into the lower part of the barrel upon the iron, and hydrogen escapes by the tube X. Attention must now be had to keep the tubes A A cool, by laying wet cloths upon them. The potassium will collect in the tube and receiver A A. T is a safety tube, for whenever the tube is stopped up with potassium, the gas will issue at T, instead of at X.

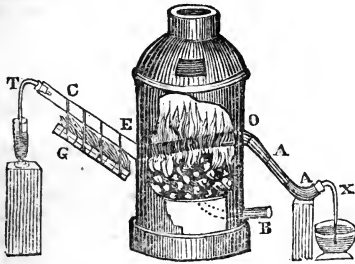

GUN METAL. The alloy for large guns is made of 112 parts brass, 14 zinc, and 7 grain tin. For small guns the following is used:— 9 parts copper and 1 part tin.

GUNPOWDER. A compound powder, used to explode in various descriptions of fire-arms. The great quantity of air liberated by the combustion occasioning a projectile force, capable of propelling bodies to a very considerable distance. Its ingredients are 78 parts of saltpetre, 12 of charcoal, and 10 of sulphur. These are ground together with great care and much labor, until they are completely incorporated with each other, and form a powder, commonly called *meal powder*, in which state it is used for fire-works of various kinds. For the use of fire-arms it is formed into grains by being rubbed through sieves, while yet in the state of a damp paste, (the ingredients being ground in water.) Being dried, it is next put in barrels, and these are turned round, so that the grains rubbing against each other become glossy, forming then *glazed powder*, or the kind most employed by sportsmen.

GUNPOWDER APPARATUS. An invention of Mr. Sturgeon, to show under what circumstance gunpowder may be inflamed by the electric shock.

A is a brass wire which has a small ball at one end, and is supported upon the glass pillar B at the other, the cap connecting the wire and glass having a chain attached to it or slipped over it. D is a metallic stand upon which the gunpowder is placed. Around D is tied a wet linen thread E about 3 inches

long, and this is terminated by a chain. When gunpowder is placed upon the top of

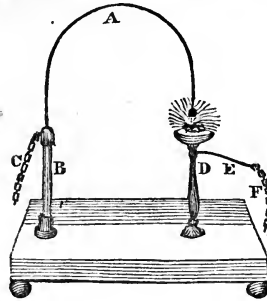

D, and the shock of a pint Leyden jar sent from one chain to the other, it will pass through the gunpowder and inflame it. The wetted thread is indispensable.

GUNTER'S CHAIN. (See *Chain*.)

GUNTER'S LINE OF NUMBERS. A logarithmic line, usually graduated on scales, sectors, &c., which therefore serves to solve problems instrumentally, in the same manner as logarithms do arithmetically. It is usually divided into 100 parts, every tenth of which is numbered.

GUNTER'S SCALE. Usually called by seamen, "*The Gunter*," is a flat scale about 2 feet long, and an inch and a half broad, with various lines upon it, both natural and logarithmic, relating to navigation, trigonometry, &c., for solving questions in which sciences it is chiefly employed. There are two variations of form in the instrument, giving the names of the *plain Gunter* and the *sliding Gunter*.

GURNEY'S OXY-HYDROGEN BLOW-PIPE. A compact, powerful, and perfectly safe instrument, for procuring a constant and intensely powerful flame, applicable to the usual purposes of a blow-pipe; that is, the melting of small quantities of refractory or difficultly fusible substances.

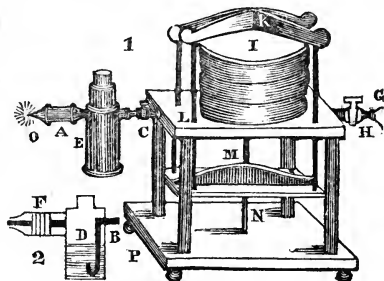

The above figure represents the apparatus complete. A and E, (fig. 1,) is the safe ap-

paratus, a section of which is seen in fig. 2, and through which the gas must pass from the gasometer, through the stop cock C. G is a transferring bladder, screwed to the stop-cock H, by which the gasometer is charged by an assistant during its action, and such a quantity of gas supplied as to keep up a flame for any requisite time. Between the gasometer and the charging bladder a valve is placed, to prevent a return of the gas. I a wood or pasteboard cap, so contrived as to unite lightness with strength; this is attached by four strings, K, to wires, which passing through holes L L in the table of the instrument, are fixed to M, a moveable press board below. When the requisite pressure or weight is placed on M, the cap I is drawn down horizontally and equally on the gasometer D; upon which the gas, (this is oxygen and hydrogen mixed together in the proportion of one part of the former to two of the latter;) is forced through the water tube B, the safety apparatus A, and out of the jet C, at the end of which it is burned. In fig. 2, the gas enters B, passes through the water at D, then through a series of wire gauzes at E, and afterwards out at the jet.

GUTTÆ, or DROPS. An ornament of the

Doric architrave, six of which are usually placed under each triglyph.



GYMNOTUS. The electrical eel. The name of a fish common in the rivers of Guiana, which possesses in itself the power of electricity, communicating a strong shock to all conducting bodies that come within its influence. It is from 2 to 4 or 5 feet in length, with rather a flat black body, covered with yellowish spots.

GYPSUM. Plaster of Paris or sulphate of lime in its natural state. (See *Plaster of Paris.*)

GYRATION. The art of whirling a body or system of bodies about one common centre.

GYRATION, Centre and Circle of. If a stick move at one end on a pivot, and the other end of it be whirled round that as a centre, the whole force will be concentrated into one point, which is called the *centre of gyration*. In an equally-balanced wheel there will be a number of such points, all equally distant from the centre, called therefore the *circle of gyration*.

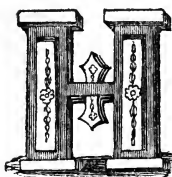

This is considered by some grammarians not to be entitled to the character of a letter, because it requires no particular conformation of the organs of voice to pronounce it. Its use, however, is established in almost all languages, ancient and modern, as an aspirate. In England it is now generally estimated as a distinct letter, necessary to the spelling of words, even more than to their pronunciation, as *alter, halter; art, hart*. It is often silent, as in *honor, hour*.

HACKING. In masonry, is the making up a course of stone, partly and properly constructed of stone hewn to an equal size by other stones which are smaller and less regular. In the following illustration the middle row of stones is hacked near one end:—

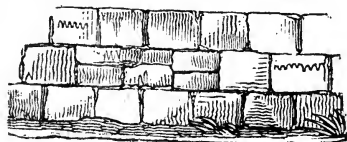

HACKLE. A kind of comb or brush made of iron spikes; used for combing or pulling the fibres of wool, so as to reduce them from a tangled to a smooth state.

HADÉ, or HADING. The direction of a *fault* in mining; or the different course which a vein of metal, or seam of coal takes after it has been broken or diverted from its former position.

HADLEY'S QUADRANT. (See *Quadrant.*)

HÆMACHROME, or HÆMATOSYN. The coloring matter of the blood.

HÆMATITE. Red iron stone.

HÆMATOXYLINE. The coloring principle of the logwood, called botanically *hæmatoxylin campechianum*.

HAIL, or HAILSTONE. An irregular rounded lump of ice falling from the atmosphere; occasioned by drops of rain being frozen by the great cold of the air through which they fall.

HAIR. The covering of animals. In the arts, hair is used for numerous purposes, as for the stuffing and covering of chairs; the blending with mortar for plastering; the making of rope and cloth; making of brushes and brooms; pencils for artists, &c.

HAIR, Head of. An electrical experiment. If a figure-head, covered with long straight hair, be placed upon the conductor of an

electrical machine, and the machine put in action, the various hairs will stand on end and be repelled from each other, as in the following cut, being an illustration of electrical repulsion:—



HAIR PYRITES. A native sulphuret of nickel which occurs in capillary crystals.

HAIR POWDER. The flour of starch, variously scented.

HAIR SALT. The native sulphate of magnesia, so called from the shape of the crystals.

HALF-ROUND. A semi-circular moulding, which may be either a bead or torus, that is, either projecting or indented.

HALF-STUFF. This term in general, implies any thing half formed, in the process of the manufacture.

HALF-TIDE DOCK. A basin connecting two or more docks, and communicating with the entrance basin.

HALF-TINT, or TEINT. In painting, such a color as is intermediate between the extreme lights and the strong shades of a picture; called also middle-tint.

HALO, or CORONA. A luminous and sometimes colored circle, appearing occasionally around the heavenly bodies, but more especially the sun and moon. It is supposed to be occasioned by the light from these bodies being reflected by the vapors of the atmosphere through which it passes. It is remarkable that the large halos surrounding the sun and moon are commonly of given diameters, namely, about 23° or 24° , or else double that magnitude.

HALOGENS, or HALOGENIA. Substances which by combination with metals produce saline compounds, such as chlorine, iodine, bromine, fluorine, which are simple halogens, and cyanogen, which is a compound halogen.

HALOID. The term is applied to a class of chemical combinations composed of two elementary compounds, one or both of which are analogous in composition to sea salt. The principal groups consist of double chlorides, iodides, fluorides, and cyanurets.

HALVING. A method of joining timbers by letting them into each other, cutting away the half thickness of each.

HAMMER. A well-known instrument for driving nails.

HAMMER BEAMS. Two beams of timber projecting from opposite sides into an apartment from the wall plate or springing of the rafters, usually supported by a corbel and rib beneath; the whole looking like a huge bracket. These in their turn support other ribs and hammer beams, of a smaller size, forming altogether an arch. The ends of the hammer beams are often grotesquely sculptured.

HAND-GEAR. That arrangement of levers, tappets, or other contrivances, which is used for opening and shutting the valves of a steam engine. (See *Beighton, Tappet, &c.*)

HAND, or HAND'S BREADTH. A measure of 4 inches; used in ascertaining the height of animals, particularly of horses.

HAND MILL. This term does not properly apply to any particular kind of mill, but to all that are worked by hand, such as are employed in the domestic offices of grinding coffee, pepper, &c.

HAND-RAIL OF A STAIR. A rail raised upon slender posts, called *balusters*, in order to prevent persons from falling down the well hole, and to assist in ascending and descending.

HANDSPIKE. A lever or pole of wood, 4 or 5 feet long, used to turn a windlass, capstan, crane, &c.

HANGING OF DOORS, &c. The act of placing them upon centres or hinges, for the convenience of opening and shutting.

HANGING STYLE. The style of a door or shutter to which the hinge is fastened.

HANGING VALVE. A flap of metal hanging down from a hinge, and which in this position suffers a hole above it to remain open; but as soon as any piston or other solid body drives against the back of it, it being thereby forced from a vertical to a horizontal position, closes the hole and acts as a valve. In rotatory steam engines and pumps such a valve is common.

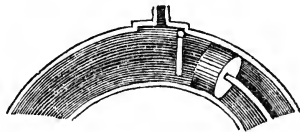

HANGS OVER. An expression which applies to a door, wall, partition, or other erection, when the top projects beyond the bottom.

HANK OF SILK, COTTON, &c. Several skeins tied together, or otherwise combined into a small bundle.

HARBOUR. A port; the entrance of a port, or such a part of a coast as incloses a

space of comparatively smooth water, where ships may anchor safely.

HARDENING OF STEEL AND IRON, is accomplished by lowering its temperature from one at or near to a red heat, to a considerably less degree. This is mostly accomplished by heating it to a certain extent, and then plunging it into cold water, or in the case of small cutting instruments into grease. (See *Case-hardening* and *Tempering*.)

HARDNESS, or RIGIDITY. That quality in bodies by which their parts so cohere as not to yield to external influence; that is, not changing their form without breaking to pieces.

HARD SOAPS. (See *Soap*.)

HARDWARE. A general term to denote all articles manufactured of metal.

HARD WATERS. Such waters as are impregnated with various salts, metals, and earths, in consequence of which they curdle soap when mixed with them. Lime, in some one or other of its numerous combinations, is the most common cause of the hardness of water.

HARE'S BATTERY DISCHARGER. A name given by Professor Hare to an instrument of his invention; the object of which is to ascertain the power of an electrical battery by the length of wire which the fluid will melt in passing through it at the time of discharge. It consists of a solid wooden foot, upon which two bent arms are placed, one of them being fixed, the other capable of moving around the centre or axis of the foot. The moveable arm is furnished with a small pair of nippers at top. The upper part of the fixed arm is of glass, and is attended by a small screw at top. The lower part, and also the foot of each, is of metal. The fine wire, which is to be made the subject of experiment, is extended across the top, from one stem to the other, they being set at the required distance, and tightened by the screw on the foot of the stand. A shock is passed through the wire, by the effect upon which the power of the battery is ascertained.

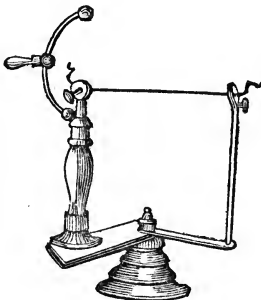

HARE'S CALORIMOTOR. (See *Calorimotor*.)

HARE'S FREEZING APPARATUS. This apparatus is to prove that water may be frozen by the cold produced by the evaporation from sulphuric acid while *in vacuo*, or under an exhausted receiver of an air pump. This instrument was contrived because the experiment frequently fails with an ordinary apparatus.

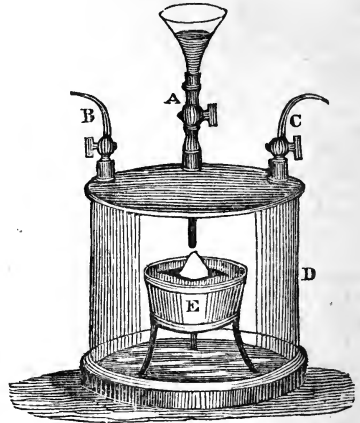

A is a tube and stop-cock furnished with a funnel at top, in which a little water is placed. B is a pipe leading to the air pump. C is a similar pipe leading to a barometer gauge. D is a glass vessel fitted with a brass cover at top, and with the wooden foot, as represented. E is a vessel raised within the outer vessel D by means of three short feet. E is filled with sulphuric acid, upon which floats a thin copper cup, containing a very little water. Water is also allowed to trickle now and then down the tube A from the funnel above. The vessel D has sulphuric acid covering the bottom, about half an inch in depth. With the above instrument Professor Hare was enabled to keep up a congelation for several days.

HARE'S SPECIFIC GRAVITY APPARATUS. (See *Litrameter*.)

HARMONICAL ARITHMETIC, is sometimes used for the application of numbers to the science of music.

HARMONICAL CURVE. An ideal curve into which a musical string is supposed to be inflected, when put into such a motion as to excite sound.

HARMONICAL PROPORTION, is when the first term is to the third, as the difference between the first and second is to the difference between the second and third; or in four terms, when the first is to the fourth, as the difference between the first and second is to the difference between the third and

fourth. Thus 6, 4, 3, and also 24, 16, 12, and 9, are in harmonic proportion.

HARMONY. In the arts, is the agreement between the various parts of a building, picture, or group of statuary, both as to the symmetry of the various parts, their decorations, and the tone of coloring.

HARMONY OF THE SPHERES. A sort of music, conceived by ancient philosophers, and supposed to be produced by the sweetly-tuned motions of the heavenly bodies.

HARPOON. A small spear, with a cord attached to it; used chiefly in the whale fishery.

HARRIS'S UNIT JAR, is a Leyden jar, having a smaller Leyden jar screwed on to the top of it, so that the inside coating of the larger is connected with the outside coating of the smaller jar. If the smaller jar be charged, it may be discharged into the larger, and so on for several times, according to the capacity of each, by which several interesting electrical experiments, showing the principle of charged surfaces, may be performed with facility and effect. It will be readily seen also, that when one of these jars is charged positively, the other jar will be charged negatively; reckoning the inner surface of each.



connected with the copper of the next, and so on throughout the series. Each piece of zinc is kept firmly in its place by three small pieces of wood, and a screw which passes through a square bar of baked wood at the top. This battery is powerful and compact, not requiring porcelain troughs for holding the acid and water, that being placed in the copper cells themselves.

HARVEST MOON. A remarkable phenomenon relating to the rising of this luminary in the harvest season. During the time she is at the full, and for a few days before and after, in all about a week, there is less difference in the time of her rising, between any two successive nights, at this than at any other season of the year. In order to conceive this phenomenon, it may be first considered that the moon is always opposite the sun when she is full; that she is full in the signs Pisces and Aries in our harvest months, these being the signs opposite to Virgo and Libra, the signs occupied by the sun about the same season; and because those parts of the ecliptic rise in a shorter space of time than others. The moon, when about the full in harvest, rises with less difference of time, or more immediately after sunset, than when she is full at other seasons of the year.

HATCHETINE. A kind of bitumen, or fatty matter, found in the argillaceous iron ore of Merthyr. It is fusible at about 160°, and inodorous when cold, but of a slightly bituminous odour when heated, or after fusion.

HAUNCH OF AN ARCH. The part between the springing and the vertex.

HARRISON'S PENDULUM. (See *Gridiron*.)

HARROW. An agricultural instrument; used for raking and levelling the earth.

HARTSHORN, Salt of. An impure carbonate of ammonia.

HARTSHORN, Spirit of. A solution of ammoniacal gas in water or liquid ammonia.

HARTSHORN SHAVINGS. Formerly obtained by shaving the horns of the deer tribe, but now by cutting the bones of calves in the same manner. They afford a nutritious and speedily formed jelly.

HART'S GALVANIC BATTERY, is composed of a number of boxes or cells, made of copper, in each of which is suspended a sheet of zinc. The zinc of one cell being

HAVY'S ELECTROSCOPE. No instrument can be more simple than this; it is nothing more than a light metallic needle, terminated at each end by a light pith ball, which is covered with gold leaf, and supported horizontally by a cap at its centre, on a fine point. The attractive or repulsive power presented to one of the balls will be indicated by the movements of the needle.

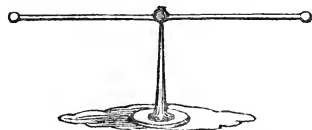

HAWSER. A large rope or small cable.

HEAD OF WATER. A term signifying a regular height of water in any stream or basin, and intended for the supply of mills, fountains, and the like. Heads of water are usually supported by banks of earth, in the same manner as dams.

HEADWAY. A name sometimes applied to the clear height under the arches of bridges, tunnels, &c.

HEADERS. In architecture, bricks or stones with their short faces in front.

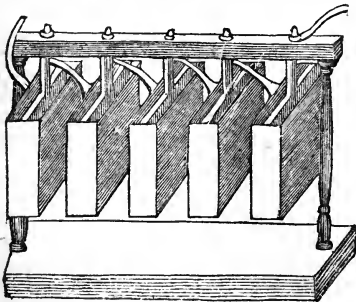

HEADING COURSES. Those courses of brick or stone-work which consist entirely of headers.

HEALD, or HEDDLE. That portion of a weaver's loom which imparts motion to the warp of a web during the process of manufacture.

HEART WHEEL. A contrivance for converting a uniform circular motion into a uniform rectilinear one. It is much employed in the machinery of the cotton and flax manufacture, and is formed after the following manner:—

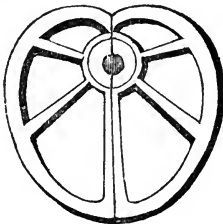

HEARTWOOD. The central or hardest part of a trunk of a tree.

HEAT. Either the sensation of burning or warmth, or the cause of that sensation which is supposed to arise from the presence in an active state of caloric or the matter of heat. (See *Caloric*.)

HEAT, Latent, Capacity for, Specific, &c. (See *Caloric*.)

HEAT REGULATOR. (See *Thermostat*.)

HEAVEN. In astronomy, the celestial sphere or firmament, or sky; denotes the spaces in which the celestial bodies are placed, or through which they apparently perform their periodic revolutions.

HEAVENLY BODIES. In astronomy, include the sun, planets, and their satellites, the fixed stars, and comets.

HEAVY INFLAMMABLE AIR. Bi-hydroguret of carbon, light carburetted hydrogen, fire damp of coal mines, inflammable air of marshes, &c. Under these names an important variety of hydro-carbon is designated, which occasionally occurs pent up in cavities in coal mines, and arises from the mud in fetid ponds and ditches; but which cannot be procured artificially. It is eight times heavier than hydrogen, burns with a yellow flame, and a slightly disagreeable odour. It consists of one volume of carbon, combined with two of hydrogen.

HEAVY OIL OF WINE. (See *Oil of Wine*.)

HEAVY SPAR. Native sulphate of barytes.

HEIGHT. The same as altitude, (which see.)

HEIGHTEN. In painting, a verb signifying to make prominent, by means of touches of light or brilliant colors, as contrasted with the shadows.

HELIACAL. As applied to the rising of a star, planet, &c., denotes its emerging out of the sun's rays, in which it was before hid. When applied to the setting of a star, it denotes the entering or immersing into the sun's rays, and thus becoming lost in the lustre of his beams. A star arises heliacally when, after it has been in conjunction with the sun, and on that account invisible, it gets at such a distance from him, as to be seen of a morning before the rising of that luminary.

HELIOCENTRIC LATITUDE OF A PLANET, is the inclination of the line drawn between the centre of a planet to the plane of the ecliptic.

HELIOCENTRIC PLACE OF A PLANET, is the place in the ecliptic in which the planet would appear, if viewed from the centre of the sun; and consequently the heliocentric place coincides with the longitude of a planet, viewed from the same centre.

HELIOCOMETES, Comets of the Sun, is used to denote a phenomenon, which sometimes attends the setting of the sun. It seems to make a comet of that luminary, having the appearance of a large tail or column of light, which follows the sun at his setting, much in the same manner as the tail of a comet.

HELIOMETER. A micrometer, which may be attached to a telescope, so that any small apparent distance between two celestial bodies may be easily ascertained. The best constructed heliometer is formed of two half lenses, the centres of which may be made to coincide, or to be separated by the screws SS, which act each upon one half lens. The distance between the centres A and B, when one is adjusted to one part of an object, and the other to the opposite part, may be ascertained by a vernier or finely divided scale, scratched upon or annexed to the half lenses.

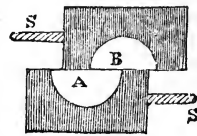

HELIOSCOPE. A telescope fitted for viewing the sun without dazzling the eyes, by being provided with object and eye glasses that are colored red or green.

HELIOTROPE. An instrument invented by Professor Gauss, of Berlin, to reflect light to great distances. It consists merely of a small mirror 3 or 4 inches in diameter, which he says will reflect the sun's light 10 German, or 40 English miles. This instrument has been found useful in trigonometrical surveys, as it reflects the light of lamps as well as that of the sun.

HELIOTROPE. A mineral of a dark green color, commonly speckled with red, called therefore *bloodstone*.

HELIX. A wreath, ringlet, a snail-shell. The smaller scroll or volute in the Corinthian capital, called also the *cauliculus* or *tendrill*. *Helix*, in physics, is a coil of wire made long and of the same thickness throughout, as in the following example :—

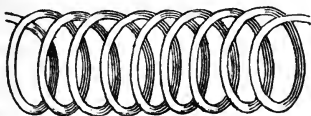

HELM. In naval architecture, the apparatus for steering or guiding a ship. It is usually composed of three parts, the rudder, the tiller, and the wheel, except in small vessels, where the wheel is omitted.

HELVER. The handle of a digging tool.

HEMATIN. (See *Hæmatin*.)

HEMISPHERE. The half of a sphere. In geography, that part of the earth, north of the equator, is called the northern hemisphere, and the other half the southern hemisphere.

HEMP. The fibres of the bark of *cannabis sativa*. It is prepared for spinning, by macerating in water, beating, washing off the impurities, and combing. But little grows in England, the greater part of our consumption comes either from Russia, Prussia, or Manilla.

HENDECAGON. (See *Undecagon*.)

HENLEY'S UNIVERSAL DISCHARGER. One of the most useful of philosophical instruments; the object of it is to enable the electrician to send a shock of electric matter through a body placed on the table of the instrument, the form of which is as follows :—

In the centre is a wooden pillar, with a hole up it, to contain the rod of a small table, which table has a piece of ivory or other non-conductor inlaid across; the table also is adjusted as to height by a screw in the side of the socket in which it fits. Near each end of the stand is a glass rod, which supports a brass cap and socket, which moves up and down. Through the socket passes a wire, which may be slipped out and in. A ring is at one end of the wire, and a ball that may be taken off or put on at the other. Any thing placed between the two balls re-

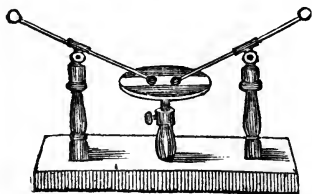

ceives the electrical shock when a current of electricity is made to pass from the one ring to the other. A small press, formed of two thin pieces of wood, adjusted by screws, is occasionally substituted for the centre table.

HENLEY'S ELECTROMETER. (See *Quadrant Electrometer*.)

HENRY'S FREEZING APPARATUS. Dr. Henry recommends the following instrument as one convenient for trying the effect of freezing mixtures :—

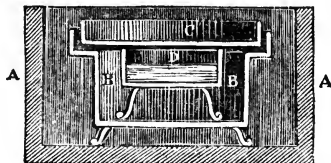

The outer vessel A A is of wood, about 12 inches square and 7 inches deep. It should have a wooden cover rabbeted in, and furnished with a handle. Within this is placed a tin vessel B B, standing on feet, which are $1\frac{1}{2}$ inches high, and having a projection at the top half an inch broad and an inch deep, on which rests a shallow tin pan C. Within the second vessel is a third, D, made of untinned iron, and supported by feet 2 inches high; this vessel is 4 inches square, and is intended to contain mercury or other liquid to be frozen. When in use, this cup, with a little mercury in it, is to be surrounded on all sides; also above and below, with a mixture of snow and muriate of lime, when the mercury will soon be frozen by the intense cold produced by the mixture around.

HEPAR. The liver, or any thing of a liver color. Among the old chemists it was synonymous with such sulphurets as approached this color.

HEPATIC AIR. Sulphuretted hydrogen gas.

HEPTAGON. A figure or surface of seven sides.

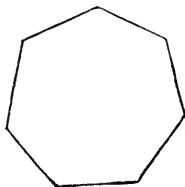

HEPTAGONAL NUMBERS. Any series of numbers formed by adding together the various terms of such an arithmetical series as increases by the addition of 5 each time, such as the following :—

Arithmetical series . . . 1, 6, 11, 16.

Heptagonal 1, 7, 18, 34.

HERBARIUM. A collection of dried plants.

HERISSON. In fortification, a beam armed with iron spikes, and used as a barrier to block up a passage.

HERMETIC ART. Alchemy, (which see.)

HERMETICAL PHILOSOPHY, is that which professes to explain all the phenomena of nature, from the three chemical principles of salt, sulphur, and mercury.

HERMETICAL SEALING, is used to denote the perfect closing of vessels, so as to prevent the ingress or egress of the most subtil fluids or bodies. In stopping glass vessels it is usual to heat the neck, until it is quite soft, and then twisting it with a pair of pincers.

HERO'S ALTAR. A kind of fountain, made to have the appearance of an altar with a priest standing beside it, which had the apparently miraculous property of supplying itself with oil; thus acting upon the superstitious ignorance of the Alexandrians, who considered this altar as under the immediate patronage of their deities. Its construction was exceedingly simple. The body of the altar was hollow, and made of metal. A lower compartment or pedestal to it was also of metal, and partly filled with oil, beneath the surface of which dipped the end of a pipe that proceeded along the body of the priest, through his arm, and to the cup in his hand. As soon as a fire was lighted on the body of the altar, the air within it was expanded by the heat, and communicating by a hole at the bottom with the lower vessel, the expanded air pressed upon the surface of the oil so as to drive it up the tube to the cup, from the



brim of which it overflowed on to the fire beneath it.

HERO'S FOUNTAIN. A jet of water which is produced by the condensation of air in the vessel from which it issues, similar in principle to the altar last described. Fig. A shows the outward form, and fig. B the inward structure. It consists of two vessels C and D, which are close on all sides. A tube G, open at both ends, having a funnel at top, passes through the upper vessel, and to near the bottom of the lower one. There is another open tube, H, soldered to the top of the lower vessel, and extending into the upper vessel to near the top of it. These two tubes serve to support the upper vessel. A third tube I is soldered to the top of the upper vessel and extends almost to its bottom.

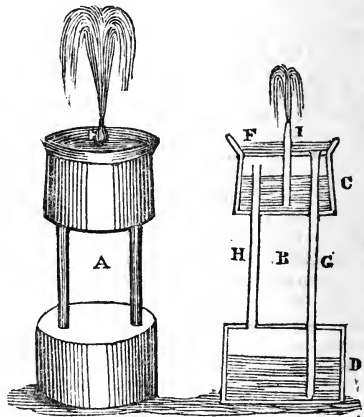

Stop the orifice I with the finger, and pour water into F, the funnel. The water will descend into D, will compress what air there is in D, and drive the water up H into C. The air in C will now be compressed, and pressing upon the surface of the water in C, will drive it up the pipe, and through the jet I, producing the fountain of water.

HERO'S STEAM ENGINE. The first attempt to derive motion from the expansion of air or water by fire. The contrivance of Hero is described under the word *Aeolipile*.

HERRING-BONE WORK. Course of stone laid angularly.

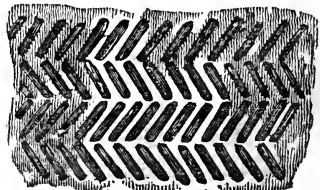

HERSCHEL'S APLANATIC COMBINATION OF LENSES. The following combination of lenses is recommended by Herschel to be used where the rigorous destruction of aberration for the central rays is required:—Two of the lenses are double convex, with the radii of their surfaces as 1 to 6, having the most convex side next the eye. The radius of the other glasses (*meniscus*) are in the first case as 1 to 1.70, and in the other case as 1 to 3.957, with their concave sides exposed to the object.

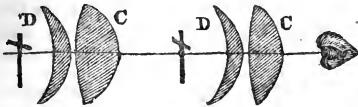

The above is to be considered as two illustrations of the same thing, the only difference being the different focus of the meniscus lens. This combination is strongly recommended as an excellent object glass to microscopes.

The following combination is also recommended by Dr. Herschel to be used when we are desirous of decreasing the aberration of a lens:—This is made of two plano-convex lenses, the foci of which should be in the proportion of 1 to 2.3, when the aberration will be 0.2481, or about one-quarter of an equivalent lens of the best form. This combination has also the advantage of decreasing the distortion of the object and diminishing the prismatic dispersion.

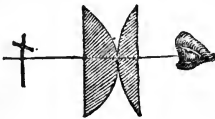

HERSCHEL'S PERISCOPIC COMBINATION OF LENSES, consists of a double-convex lens of the best form, (that is, with the radii as 6 to 1,) but in its worst position. This lens is to be employed for that next the eye, as follows:—A

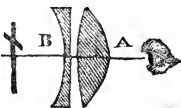

And a plano-concave lens B, with its concave side next the object. The proportion of the foci of the two lenses being as 5 to 13. By this construction a very extensive field of view is obtained with moderate distinctness. In reading glasses and magnifiers of

lower power a distinct field of 80° may be obtained.

HETEROGENEOUS. Unlike each other. *Heterogeneous quantities* in mathematics are such as cannot be compared, as lines with surfaces, surfaces with solids, &c. Heterogeneous light, is that which consists of rays of different degrees of refrangibility.

HETEROSCIU. In geography, are such inhabitants of the earth as have their shadows at noon always projected the same way with regard to themselves, or always contrary ways with regard to each other. Thus all the inhabitants without the torrid zone have their shadows at noon directed the same way; viz., always north of them in north latitude, and south of them in south latitude.

HEWN STONE. Stone reduced to the shape required for use, and cut with a mallet and chisel.

HEXAEDRON. The same as cube.

HEXAGON. In geometry, a plane figure bounded by six straight lines.

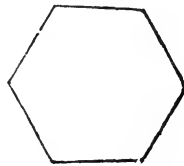

HEXASTYLE. A temple with six columns to the portico.

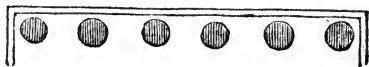

HIDE. The strong skin of large animals, such as the ox, horse, &c.

HERO. (See *Hero*.)

HIGHGATE ROSIN. A fossil resin, discovered on cutting the road through Highgate Hill; it is embedded in the clay in roundish nodules.

HIGH PRESSURE APPARATUS. An apparatus intended to show that fluids, subjected to a greater degree of pressure than the atmosphere, require higher degrees of heat to make them boil.

The hollow globe A is composed of two strong hemispheres of brass, screwed together with flanges; some quicksilver is first poured into this globe, which is then about half filled with water. The barometer tube B passes through a steam-tight collar, and has its lower end immersed in the quicksilver. C is a thermometer, for ascertaining the temperature of the water during the experiments; its scale is graduated up to 400°, and passes through a steam-tight collar. D is the brass

frame and stand upon which the globe rests. E is a spirit lamp, and F is an aperture,

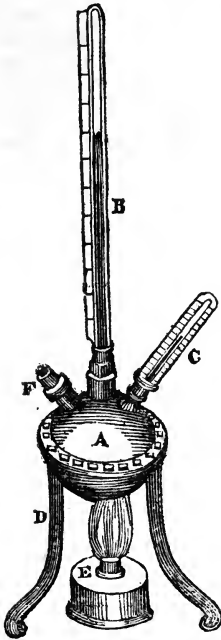

closed by a stop-cock. The stop-cock being closed, and heat being applied, the mercury gradually rises in the tube, indicating the pressure; while the temperature may at the same time be known by the thermometer C.

HIGH PRESSURE ENGINE. The simplest form of the steam engine is the non-condensing or high pressure engine. In this engine the condensing apparatus is done away with, and steam being admitted into the cylinder, at a high temperature, and consequently high pressure, and having acted on the piston is allowed to escape into the open air. A part of the force of the steam is of course expended in overcoming the pressure of the atmosphere, and it is only that portion of the steam's elastic force, that exceeds 15 lbs. to the square inch, that is effective in moving the engine. The surplus pressure is usually from 30 to 40 lbs. on the circular inch. The boiler must be amazingly strong, and the water being heated to a very high temperature, portions are successively let out, and immediately bursts into steam.

HIGH WATER. That state of the tides when they have flowed to the greatest height, in which state they remain nearly stationary for about fifteen or twenty minutes, when the water begins again to ebb or recede. The

time of high water is always nearly the same in the same place at the full of the moon, and at all other times; the time of high water depends upon the age of the moon. The rule for finding which, the age of the moon being given, is as follows:—Add four-fifths of the days of the moon's age, as so many hours to the time of high water at the full of the moon, and the sum is the time of high water, answering to that day *nearly*. The time of high water at London, on the day of the full moon, is 3 o'clock in the afternoon.

HINGE. Metal jointed bands, upon which doors, shutters, lids, &c. turn in the act of opening and shutting. There are twenty or thirty kinds of hinges adapted for various purposes.

HIP KNOBS. Ornaments at the gable end of houses, &c.



HIPPODROME. A horse course, or space of inclosed ground adapted for the exercise of horses.

HIPPURIC ACID. A peculiar compound deposited from the urine of the horse, when it is mixed with hydrochloric acid. It closely resembles, and is sometimes substituted for benzoic acid, but it contains nitrogen, and its salts are distinct from the benzoates.

HIPS. The pieces of timber that form the angles of a hipped roof, and upon which the rafters are attached.

HIP ROOF. A roof whose ends slope in the same degree with the sides.

HIPTILES. Tiles adapted to cover a ridge or hip, therefore called ridge tiles.

HIRCINE. A liquid fatty substance which is mixed with the oleine of mutton suet, and gives it its peculiar rank smell.

HIRCIC ACID. An acid obtained from hercine.

HOARD, HOARDING, or HORDING. An inclosure about a building while erecting or under repair.

HOE. An instrument used in agriculture and gardening, for cutting up weeds and earthing up plants.

HOLD. The whole interior cavity of a ship, comprehended between the floor of the

lower deck and the bottom of the vessel throughout her whole length.

HOLDFAST. The name of a tool, used to hold or retain steadily any work upon the bench whilst being operated upon. The common holdfast is merely a bar of iron bent at right angles, one leg being driven into a slightly oblique hole in the bench, the extremity of the other leg holding the work. The following is a much superior holdfast, invented by Mr. Dungey, of Compton Street, Soho:—The arm A, instead of being one piece, with the rest of the bar, is moveable on the screwed axis B, and is prolonged backwards, as D. In this latter part is a hole for the reception of a handled screw, which bears on a projection of the main bar. C is a hole in the bench E, and F is a flat piece fixed by a loose joint to the arm A, and therefore capable of bearing, by its whole surface, on any piece of work placed under it. By turning the screw in one direction, the work is held fast; by turning it in the other, the work is loosened.

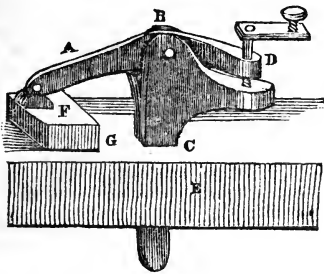

HOLDER OF A MAGNET. The same as armature.

HOLING. A word used by miners, to signify undermining coal, stone, &c. previous to breaking it down from above.

HOLLAND. A closely-woven linen cloth, of a peculiar fabric, so called from its having been originally imported from Holland.

HOLLOW. A concave moulding, synonymous with casement, (which see.)

HOLLOW NEWEL. A well-hole or opening in the middle of a staircase. The term is used in contra-distinction to *solid newel*, into which the ends of the steps are built. Hollow newels always belong to geometrical staircases.

HOLLOW WALL. A wall built in two thicknesses, leaving a cavity between, which may be either for saving materials, or for preserving a uniform temperature in apartments.

HOLLOW QUOINS. In engineering, piers of stone, large bricks, or solid posts of oak, made behind each lock-gate of a canal, which are formed into a hollow from top to

bottom, to receive the rounded head of the lock-gate.

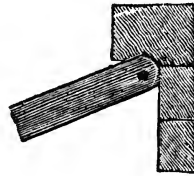

HOMBERG'S PHOSPHORUS. When chloride of calcium, that is, perfectly dry muriate of lime, is fused in a crucible, it acquires a phosphorescent property, as was first observed by Homberg, and hence it was termed *Homberg's phosphorus*.

HOMBERG'S PYROPHORUS. When potash alum is ignited with charcoal, a spontaneously inflammable compound results, which has long been known by the above title.

HOMBERG'S SEDATIVE SALT. Boracic acid.

HOMOCENTRIC. Having the same centre; the same as concentric.

HOMOGENEAL. Similar to, or of like parts and qualities. *Homogeneous* light is that whose rays are all of one, and the same color, degree of refrangibility, and reflexivity.

HOMOLOGOUS. Equal or similar to; as in mathematics, the corresponding sides of similar figures are homologous.

HONE. A kind of stone; called by mineralogists *whet-slate*, used for the sharpening of cutting instruments. The best is found in Germany.

HONEY. A sweet and scarcely fluid substance, which is collected by bees from the nectaria of flowers, and deposited in the cells of the combs for the support of the bees and their offspring. There are three sorts of honey; *virgin* honey, which spontaneously flows from the young combs when taken from the hive, and put to drain. *White* honey, which is thicker than the former, and often indeed almost solid: it is procured by pressing the combs, but without the assistance of heat; and the *common yellow* honey, obtained from the combs, first heated over the fire, and then pressed.

HONEY COMB. **HONEY COMB WORK.** A honey comb is the cellular fabric made by bees in wax, in which they deposit their honey. Hence in the casting of iron, or other metals, when the work is not solid, but cellular or spongy, it is denominated honey-comb work.

HOOD. A cowl or covering, placed on the top of any thing, as the hood of a chimney pot, &c.

HOOD MOULDING. A band or string over the head of a door, so called from its in-

closing, as with a hood, the inferior mouldings. This term, as well as *label* moulding and *weather* moulding, are used synonymously.

HOOPS OF ANIMALS. Coagulated albumen, like horn.

HOOKE'S UNIVERSAL JOINT. A contrivance for producing an alteration in the axis of motion of various parts of machinery. It is either *single* or *double*, as exemplified below. If the shanks or spindles to be turned are less inclined to each other than about 140° , the double joint must be made use of.

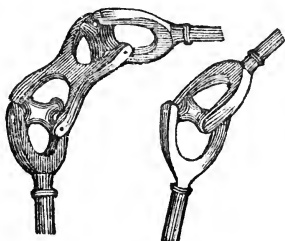

HOOP. A pliant piece of wood or metal, made into a ring or circular bandage, for holding together the staves of casks, and other similar purposes.

HOPE'S EUDIOMETER. (See *Eudiometer*.)

HOPPER. A trough or funnel, employed to supply corn to a mill, fuel to close furnaces, and a variety of other similar purposes.

HOPS. The dried flower case and seed of a British climbing plant, called by botanists *humulus lupulus*, which grows wild in many parts of England; but for the purposes of commerce and brewing, cultivated chiefly in the counties of Kent and Surrey. There are several varieties in cultivation; the principal of which are the *red bind*, the *green bind*, and the *white bind*.

HORARY. Relating to hours. *Horary circles* are hour lines or circles, marking the hours on globes, dials, &c

HORARY MOTION. The motion or space moved in an hour: the horary motion of the earth on its axis, or the apparent horary motion of the sun is 1° .

HORDEINE. A name given by Proust to the peculiar starchy matter of barley. It seems to be a mixture of starch, lignine, and husk, constituting barley-meal.

HORDING. (See *Hoard*.)

HORIZON. In geography and astronomy, a great circle in the sphere, dividing the world into two parts or hemispheres, the one, upper and visible, the other, lower and hid. The horizon is either rational or sensible. The *rational*, *true*, or *astronomical* horizon, which is also called simply and absolutely the horizon, is a great circle whose

plane passes through the centre of the earth, and whose poles are the zenith and nadir. It divides the sphere into two equal parts or hemispheres. The *sensible*, *physical*, *visible*, or *apparent* horizon, is a lesser circle of the sphere which divides the visible part of the sphere from the invisible; or in other words—If a person look around him, and his view be not obstructed by near objects, the sensible horizon will be his utmost extent of view on all sides, or the circle which bounds his view on all sides. This circle or plane is divided into two parts, the *eastern* or *artive* horizon, where the heavenly bodies rise; and the *western* or *occidial* horizon, or that wherein the stars and other bodies set.

HORIZON OF A GLOBE. The broad, wooden, circular ring in which the globe is fixed. On this are several concentric circles which contain the months and days of the year, the corresponding signs and degrees of the zodiac, the 32 points of the compass, &c.

HORIZON, Artificial. An instrument used in connection with the quadrant or sextant for obtaining the altitude of a heavenly body, to procure which, a perfectly horizontal reflective surface is necessary. At sea, in fine weather, the apparent horizon, as seen in the distant water, is sufficient; but during a hazy atmosphere, or when on land, the artificial horizon is necessary. It consists of a triangular box, the two sloping sides of which are of glass. The box, which is without a bottom, is placed over a shallow dish of quicksilver. The ray of light from the heavenly body A strikes the fluid mercury B, and is reflected by an equal distance to the eye, or in other words, the quadrant at C.

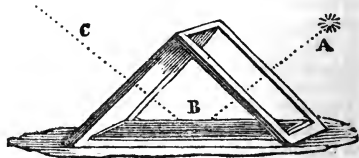

HORIZONTAL. Relating to or parallel with the horizon. A *horizontal dial* is one drawn on a plane parallel to the horizon, having its gnomon or style elevated according to the altitude of the pole of the place it is designed for. *Horizontal distance* is that estimated in the direction of the horizon. *Horizontal line*, or base of a hill, in surveying, is a line drawn on the horizontal plane of the hill, or that surface on which it stands. *Horizontal moon*, is the moon when rising or setting, at which time she appears considerably larger and redder than when nearer the zenith.

HORIZONTAL LINE. In perspective, is such an imaginary line in a picture as is parallel to the horizon, and at the height of

the eye. It therefore passes through the centre of the picture.

HORIZONTAL WHEEL, or TUB WHEEL, is a water wheel which is supported horizontally, and moved by the stream of water washing against one side of it. This method is said to be common on the Continent, but is seldom employed in England, on account of the disadvantageous method in which the power is applied.

HORIZONTAL WINDMILL. This name is given to those windmills which turn on a vertical axis. In the most common forms, the sails, like float boards, present their broadside to the wind on the acting side of the wheel, but are folded up or turned edgewise on the returning side. These wheels, however, are found to be greatly inferior to the vertical windmill, in the amount of work which they are capable of performing.

HORNBLOWER'S STEAM ENGINE, is an expansive engine, the principal force of which is produced in two cylinders. The figure annexed will give a general idea of this contrivance without showing any of the smaller parts, which being similar to those of common engines, and not to confuse the figure, are omitted. A is a small cylinder, having a piston within it, the rod of which is attached to the beam; this cylinder communicates with the boiler by the pipe K. E is a pipe with a stop-cock, which opens a communication between the bottom of the small cylinder A and the top of the larger cylinder B. F is a pipe and cock leading to the condenser.

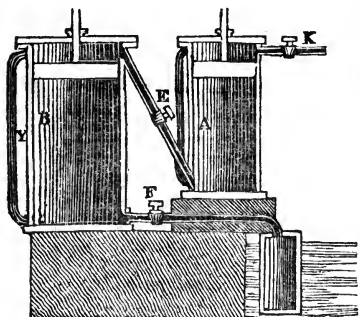

HORN. An animal substance, chiefly membranous, composed of coagulated albumen, with a little gelatine, and about half a per cent. of phosphate of lime. The word horn is also used by architects to signify the Ionic volute, and artisans call by the word horn any piece of timber, or metal, which projects beyond the general surface, or beyond that part of the timber which is useful.

HORN, Artificial, or Tanned Gelatine. A French manufacture, for the construction

of a variety of articles, such as snuff boxes, knife handles, &c. The gelatine is obtained from bones, by treating them with a weak solution of muriatic acid, and it is afterwards tanned by the common process, as in making leather. Upon becoming hard and dry, it assumes the appearance of horn or tortoise-shell. It is softened by being boiled in water with potass, when it may be formed into any shape, and the figure preserved by drying the articles between moulds.

HORN DRUM. A particular kind of machine for raising water, very similar to De la Faye's pump. It is formed of a number of segments passing from the circumference of a large flat cylinder to its centre. The mouths or scoops, at the circumference of the wheel, by turns dip into the water, and as they rise retain it, until passing over to the other side, the water is discharged into a trough prepared to receive it. The following cut shows the horn drum in section, whereby its construction may be immediately understood:—

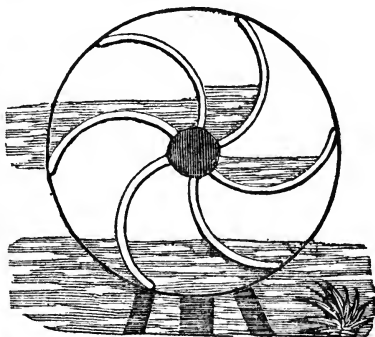

HORNSILVER. Chloride of silver.

HOROGRAPHY, or HOROLOGIOGRAPHY. The art of dialling, or otherwise ascertaining the hours.

HOROLOGY. The art of constructing machines for measuring time; but from the circumstance of clocks and watches having very generally superseded all other contrivances for this purpose, the term is now usually understood as referring to these instruments solely.

HOROPTER. In optics, is a right line drawn through the point where the two optic axes meet parallel to that which joins the two pupils.

HOROSCOPE. In the exploded science of astrology, denoted the degree or point of the heavens rising above the eastern point of the horizon at any given time, when a prediction was to be made of a future event; as the fortune of a person then born; the success of a design then laid; the weather, &c. Horoscope is also used for a scheme or figure

of the twelve hours, that is, the twelve signs of the zodiac, wherein is marked the position of the heavens for any given time.

HORSE-POWER. In steam engines, is estimated by Mr. Watt, that 30,000 pounds, avoirdupois, lifted one foot per minute for one horse. A steam engine, therefore, which is capable of doing twenty times this work, is said to be of twenty horse-power, and so on for other measurements.

HORSE-SHOE MAGNET. (See *Magnet.*)

HOSE. A term given to a flexible tube attached to hydraulic engines, for conveying water or other fluid to any required point.

HOT-BEDS. In gardening, are beds made of fresh horse-dung or tanners' bark, and covered with glasses to defend them from inclement weather.

HOT-HOUSE. A garden erection, employed either for forcing plants, or for the training of exotics; provided with a stove or flue for the diffusion of artificial heat, and the means of duly regulating it.

HOT-PRESSING is, strictly speaking, the art of applying heat in conjunction with mechanical pressure; but it is generally understood to mean the employment of that process to paper, linen, and similar fabrics, by which they acquire a smooth and glossy surface. The mode of operating is as follows:—A number of stout iron plates are heated in an oven constructed for the purpose; when they have acquired the proper temperature, they are taken out and put into a screw press, in alternate layers, with the goods to be pressed; and when paper is the material to be operated upon, the various sheets are put also between glazed boards, the smoothness of which communicates the lustre by which hot-pressed paper is distinguished.

HOUR. An aliquot part of a natural day, usually a twenty-fourth part, but among the ancient Egyptians and Jews, a twelfth part.

HOURLY CIRCLES, are depicted on the artificial globe; they are great circles of the sphere meeting in the poles of the world, and crossing the equator at right angles. They are drawn through every fifteenth degree of the equator or equinoctial, consequently there are 24 around the circle, each answering to an hour.

HOUR GLASS. A popular kind of time-keeper, which indicates the hours by the running of sand, water, or mercury, from one vessel to another.

HOUR LINES ON A DIAL, are those which are drawn for the purpose of pointing out the hours by the progress of the sun.

HOURIET'S PYROMETER, or **METALLINE THERMOMETER.** An extremely delicate and compact instrument, which indicates with rapidity and exactness, the smallest changes of temperature. It is made in the form of the common watch, marked on the face with

a certain number of degrees, and having a fine hand passing through the centre, by which the indications of the instrument are seen. Under the dial is the simple spring-work seen in fig. 2, where A, B, C, is a compound bar or wire coiled up and doubled upon itself for the sake of convenience. This part is composed of a plate of steel and one of brass united together into one bar. The steel plate is one-fiftieth of an inch in thickness, and the brass twice as much, forming altogether a bar $9\frac{1}{2}$ inches in length and about one-seventh of an inch in depth. One extremity of this is fastened at C to the frame. The other end is free to press against the short arm E of the lever B, F, the longer arm F turning a small toothed wheel which works the hands on the opposite side of the dial. Under G is a slight wire spring to keep the lever closely pressed against D during its recoil by coil.

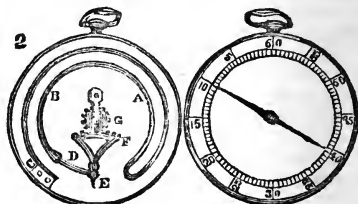

HOWARD'S THERMOMETER. This is a modification of the valuable differential thermometer of Mr. Leslie: it being considered by Dr. Howard as more convenient, from occupying less lateral space, and from having one ball elevated above the other. The included liquor is not sulphuric acid, as in Leslie's instrument, but alcohol or ether, colored, which is made to boil for the purpose of excluding the air. It is furnished with a scale of 100 equal parts, and is fixed to a wooden support. When both balls are exposed to the same temperature it is not in the least affected; but as soon as one of the bulbs is exposed to a higher temperature than the other, the difference between them is delicately shown by the falling of the colored fluid below the bulb which is most heated.



HUE. In painting, any degree of strength or vividness of color, from its greatest or deepest, to its weakest shade. Hue is usually applied to mixed or compound colors, and tint, to the primitive or single colors.

HUMIDITY. Moisture; the quality or power of wetting or moistening other bodies.

HUNDRED OF LIME. A denomination of measure; in some places denoting 35, and in others, 25 heaped bushels or bags.

HUNGARIAN MACHINE. An instrument for raising water, so called from its being employed in draining a mine in Chemnitz, in Hungary. It produces its action by the condensation of a confined portion of air, produced by the descent of a high column of water contained in a pipe, and therefore acts with a force proportionate to the weight of such column.

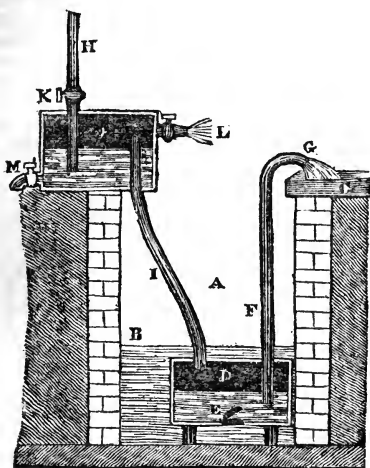

A is supposed to be a well or the shaft of a mine, from the bottom of which it is necessary to raise the water standing at the level B to the surface of the ground C, where the discharged water must have an opportunity of escaping, either by running to waste or being converted to some useful purpose. H is supposed to lead from the spring or other elevated source, whence the supply of water for working the machine may be obtained. The acting part of the machine consists of two cisterns, D and J, both made strong and air-tight. The lower cistern is sunk beneath the surface of the water in the well, yet is not quite in contact with the bottom of it. An open pipe F passes from near the bottom of this cistern through its top in an air-tight manner, and proceeds upwards as far as the surface of the ground, where it bends over to deliver the water, as at G. Another open pipe I, which may be of rather smaller dimensions than the last, proceeds from the top of the lower chest to very near the top of the chest J; and a third pipe of the same capacity as the first, proceeds from very near the bottom of this chest up to the reservoir or spring, but has a cock in it at K, by which it can be oc-

asionally shut or opened. A cock of large dimensions is also fixed at M to withdraw the water from J, and a smaller cock I for discharging its air. To put the machine in action, shut the cocks K and M, and open the cock I. This, by withdrawing the air, will fill D with water, which passes through the valve E. When D is full of water, the cock I is to be shut and K opened, when a column of water, equal to the full height and pressure of the cistern forming the reservoir, will rush down, partly fill J with water, condense the air above this, and also condense the air in D, and this pressing of the water in D will drive it up the pipe F.

HUNGARY WATER, is made by distilling in a water bath, two pounds of the fresh gathered flowers of rosemary, with two quart. of spirits of wine.

HUNTER'S SCREW. An instrument of great mechanical efficiency, the contrivance of Mr. Hunter, surgeon. A perspective drawing is given in the following cut:—

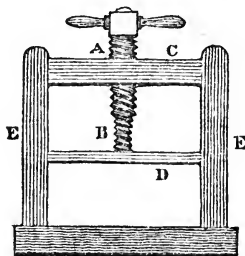

E E is a strong frame in which a board D moves, so that when it is forced towards the bottom it will exert a pressure on any substance placed beneath. To the board D is attached the screw B. C is a fixed board, through which a screw A passes. The screws move within each other, and according to the relative size of the thread of each, so will be the power of the whole.

HUNTING COG. When wheels of exact ratios work into each other, there is often occasioned an inequality of wear arising from one, two, or more cogs being of harder or softer material than the rest. This is much increased by the exact relative ratio of the two wheels, because each cog of one wheel meets the same cog of the other wheel a certain number of times in every revolution of the large cogs; for example, if one wheel have sixty cogs, and the other ten, the same cog of the smaller wheel will always strike every sixth cog of the other, and when this has been turned once, it will take hold upon the same cog again. To avoid this, the larger wheel should be made with sixty-one cogs; the odd one, being called the *hunting cog*.

HYACINTH. A gem of a red, brown, or more rarely, yellow, or green color. It occurs in small angular crystals of considerable lustre; it is harder than quartz, but softer than topaz. The best is brought from Ceylon.

HYDRATES. Compounds in definite proportions of metallic oxides with water.

HYDRAULICS, is the science which explains the laws and properties of fluids in motion.

HYDRAULIC, OR HYDROSTATIC PRESS. (See *Bramah*.)

HYDRAULIC ENGINES. All kinds of machines which either receive motion from the weight or impulse of water, or are employed in raising it. (See *Lift, Force, Suction, Chain, Rope, and other Pumps, Archimedes's Screw, Hungarian Machine, Bucket Engine, Horn Drum, De la Faye, De la Hire, &c. &c.*)

HYDRAULIC BLOW-PIPE. (See *Tilley*.)

HYDRAULICON, OR WATER ORGAN. A musical instrument acted upon by water, the invention of which is said to be of higher antiquity than the wind organ. We are not aware that its construction is anywhere described.

HYDRIODATES. Salts consisting of hydriodic acid combined in definite proportions with various oxides.

HYDROCHLORIC ACID. *Muriatic Acid.* A compound of chlorine and hydrogen. In chemistry and medicine, the term hydrochloric acid; and for its salts, the term hydrochlorides is used; but in the arts and manufactures, the older words *muriatic acid* and *muriates* are still mostly employed.

HYDROCHLORIDES. Combinations of hydrochloric acid and various bases.

HYDROCYANIC ACID. Prussic acid, (which see.) A compound of cyanogen and hydrogen.

HYDRODYNAMICS. The science which treats of the mechanical properties of fluids in general. It is divided into hydrostatics, hydraulics, and pneumatics.

HYDROGEN, is a colorless gas, permanently elastic, without taste, and when perfectly pure, without smell. It is the lightest body known, being sixteen times lighter than oxygen, or thirteen times lighter than atmospheric air; its specific gravity being 0.0694, and 100 cubic inches of it weighing 2.118 grains. It cannot support combustion or respiration, but is itself in an eminent degree inflammable, requiring, however, oxygen to support the combustion; it may be set fire to by any material made red hot, it explodes when mixed with oxygen or the atmospheric air, forming water, and its heat when burning is greater than that of any other material.

HYDROGRAPHY. That part of geography which relates to seas or oceans.

HYDROGRAPHICAL MAP. A chart representing the ocean, or some part of it, seas, rivers, &c.

HYDROLOGY. A discourse upon the mechanical properties of water, or the science of hydrodynamics.

HYDROMANCY. Divining by water. This branch of the cabalistic art was performed by means of a vessel, called a hydromantic vessel, constructed as follows:—A B is a square box with the glass partition C fixed water-tight across it. Under this is a mirror D placed at an angle of 45°, and in the side opposite to it a tube holding a lens E. Whatever was put before the lens, as for example, the answer to a question, was reflected from the mirror D to C, and through the water above to the eye of the inquirer. If the lens be extended through a partition, the deception is more complete.

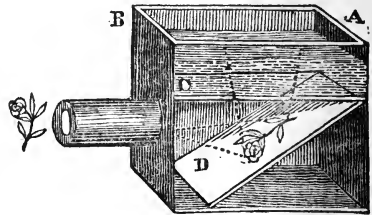

HYDROMETER. An instrument for ascertaining the specific gravity of different liquids.

The commonest hydrometer is formed of a glass tube, as in the margin, the lower ball being partly filled with shots, and the stem containing a paper scale. This being all glass externally, it may be applied to ascertain the specific gravity of acids and other corrosive substances. For ascertaining the strength of spirits, a superior instrument is used, invented by Mr. Sikes; it is shown in the margin, and is formed wholly of brass, and may be described as consisting of three parts:—A the scale, B the ball, and C the stem, which terminates in a small knob, intended to keep the instrument upright when in use. Upon this being put into a long glass, containing spirits of wine, brandy, gin, &c. it will sink to a certain depth. If the spirit be very weak, it may not sink low enough to cover the ball B, in which case one of the weights D, E, F, or G, is placed above the knob of the lower stem. According to the weight used, and the degree to which the instrument sinks, reference being had also to the temperature of the fluid, the degree of strength is ascertained.

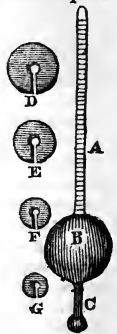

HYDROMETER PROOF. An expression used by distillers, publicans, and others, to signify

a standard degree of strength of spirits of any kind. The scale of the spirit hydrometer is considered to range from 0, which signifies water; to 200, which indicates pure or absolute alcohol. Half way between these two points, that is, 100, is *hydrometer proof*, and the strength of spirits is considered according to this point. Thus, cordials, such as peppermint, anise, &c. do not indicate a quantity of spirit above 50° *under proof*, or are three-quarters water. Best gin is about 22 per cent. *under proof*. Strong brandy, 8 per cent. *over proof*; and the strongest spirits of wine that can be made by ordinary distillation, about 66° *over proof*, or it may be said to have one-sixth part water still attached to it.

HYDROMETRY. The mensuration of water and other fluids; their density, gravity, force, &c.

HYDROMETRIC. Said of substances which are easily affected by changes in the weather, becoming dry or moist as the atmosphere becomes so, or which readily absorb, and part with moisture. Among such substances are sea weeds, uncleaned sponge, several saline substances, porous clays, potass and its carbonate, sulphuric acid, chloride of lime, &c. Dried animal bodies, such as catgut, ropes, linen, &c.

HYDROGURETS. Combinations of hydrogen and various bases. Thus most of the carburetted hydrogens are hydrogurets of carbon.

HYDROGURET OF PHOSPHORUS. (See *Phosphuretted Hydrogen*.)

HYDROSCOPE. An ancient instrument for measuring time by the running of water. (See *Clepsydra*.)

HYDROSTATICS. The science which explains the properties of the equilibrium and pressure of liquids, particularly of water, when in a state of rest.

HYDROSTATIC BALANCE. An instrument used for determining very accurately the specific gravity of bodies, whether fluid or solid. There are various constructions given to this instrument, but the following appears to be one of the most accurate and delicate:—A C C is the stand or pillar of this hydrostatic balance, the lower end of which is fixed in a table. From the top A hangs, by two silk strings, the horizontal bar B, from which is suspended from a ring the fine beam of a balance G, which is prevented from descending too low on either side by the gently springing piece F, supported by the projecting arm E. The strings by which the balance is suspended passing over two pulleys, one on each side of A, are carried over a third pulley on the top of C, through which they descend, and are attached to a small lever at D, by means of which the balance is lifted or depressed when in use. H H

is a small board, fixed to the stand, and under the scales, and is moveable up and down on the stand C, and fastened at any part by means of a screw behind. From the point in the middle of each scale hangs by a fine hook a fine brass wire. These pass through two holes in the table H H. One wire, marked J O, is covered with a case of another wire, which is marked in degrees and minutes, and is about 5 inches long. This passes easily and smoothly through a hole in a bent arm, projecting below the board H H. To the lower end of the wire J O is suspended a weight, and below that a wire with a small brass ball P. To the wire I of the other scale is suspended, by a single horse hair, a large glass bubble.

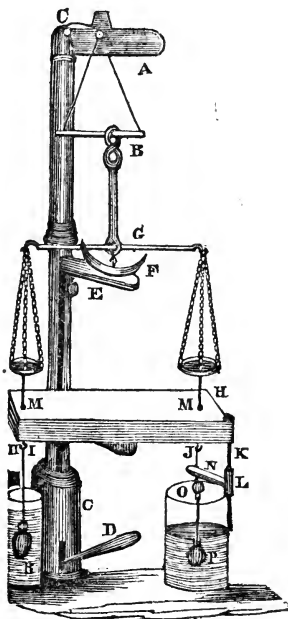

HYDROSTATIC BELLOWS. (See *Bellows*.)

HYDROSTATIC PARADOX, is that any quantity of water, however small, may be made to lift and balance any quantity however great; thus, water in a pipe open at both ends always rises to the same height in each, whether those ends be wide or narrow, equal or unequal. Thus, the small quantity of fluid which fills the pipe B D in the following illustration exactly balances the large quantity of fluid in the vessel A E C, the fluid standing at the same level in each. It is quite immaterial what is the shape of either vessel, or their relative sizes. The weight of water in B D, be it ever so small,

will nevertheless counterbalance that contained in the other vessel, however large or however irregularly shaped it may be.

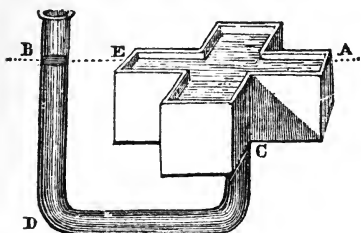

HYDROSTATIC PRESS. (See *Bramah*.)

HYDROUS. Watery, or any thing containing water in its composition.

HYDRO-OXALIC ACID. A peculiar acid formed during the action of nitric acid on sugar, gum, and other substances. When in its utmost state of concentration, it is in the form of a syrupy, colorless, inodorous, and intensely sour liquid, of the specific gravity of 1.415 at 60° Fahr. It is deliquescent, and unites in all proportions with water and alcohol, but is only sparingly soluble in ether.

HYDRURETS. Compounds of hydrogen with metals.

HYDRO-OXYGEN BLOW-PIPE. (See *Clarke and Gurney*.)

HYDRO-OXYGEN MICROSCOPE. A microscope, the illuminating power of which is derived from the intense reflection of light produced by throwing the oxygen and hydrogen gases in an inflamed state upon lime. (See *Oxy-Hydrogen Microscope*.)

HYDRO-PHOSPHORIC GAS. Hydro-phosphorous acid when in a gaseous state.

HYDRO-PHOSPHOROUS ACID. A peculiar combination of the phosphoric acid and hydrogen. It is not spontaneously inflammable, but explodes when heated with oxygen.

HYDRO-PNEUMATIC APPARATUS. A general name for all the apparatus used in the holding, measuring, making of, and otherwise experimenting upon those gases which are not absorbable by water, or which are absorbable in so small a degree as to render the partial absorption of little practical consequence. The hydro-pneumatic apparatus may be said to comprise gasometers and holders, gas jars, retorts, gas cocks, receivers, pneumatic troughs, &c.

HYDRO-SULPHATES. Combinations of sulphuretted hydrogen gas with various bases, particularly metallic; forming variously colored pigments, called the metallic hydro-sulphates.

HYDRO-SULPHO-CYANIC ACID. A triple compound of cyanogen, sulphur, and hydrogen.

HYDRO-SULPHURETS. Compounds of sulphuretted hydrogen with the salifiable bases.

HYDRO-SULPHURIC ACID. (See *Hydrothionic Acid*.)

HYDRO-SULPHUROUS ACID. When two volumes of sulphuretted hydrogen are mixed in an exhausted vessel with one of sulphurous acid they mutually decompose each other, occasioning the production of water and the deposition of sulphur. According to Thompson, the deposited matter is not sulphur, but a compound of sulphur, oxygen, and hydrogen, which he calls *hydro-sulphurous acid*.

HYDRO-THIONIC ACID. Sulphuretted hydrogen; the hydro-sulphuric acid of M. Gay Lussac.

HYGROMETER, or HYGROSCOPE. An instrument for ascertaining the degrees of dryness or moisture of the atmosphere; therefore whatever substance expands by moisture, or contracts by dryness, may be employed for the purpose, in connection with a suitable index and scale, showing the changes it undergoes. The following is a very simple and easily constructed hygrometer:—

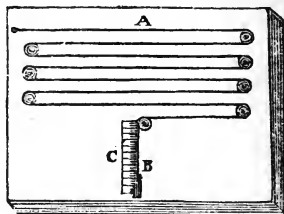

A is a long piece of catgut, fastened to a pin at one end, and made to pass over a number of small pulleys, as represented, terminating at the lower end with a small weight, behind which is a scale of equal parts. According to the drought or moisture of the air, so the catgut will contract or lengthen, the degree of such alterations being indicated by the weight in front of the scale.

HYGROMETER, Thermometric. (See *Leslie*.)

HYOSCIANA. A vegetable alkali, extracted from the *hyoscyamus niger*, or *henbane*. It is a strong poison.

HYPÆTRAL TEMPLE. A temple with

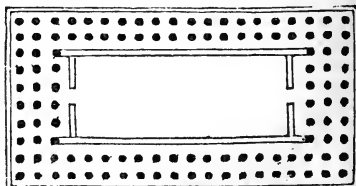

ten columns in front and at the back, and also two rows of columns entirely round the walls of the building. The centre part, or cell, was open to the air at top.

HYPERBOLA, APOLLONIAN HYPERBOLA, or HYPERBOLIC CURVE. One of the sections of a cone, being that which is made by a plane perpendicular to the base, but not passing through the apex, as appears in the annexed cut, where two hyperbolas are seen to be cut off two opposite cones. The next figure shows part of the curved lines of these hyperbolas, with their different parts and properties. A B joins the vertices of the cones or hyperbolas. Bisecting A B in C, any right line drawn through C, which is called the *centre*, and terminating in both curves, is a *transverse diameter*, and of all these diameters A B is the shortest.

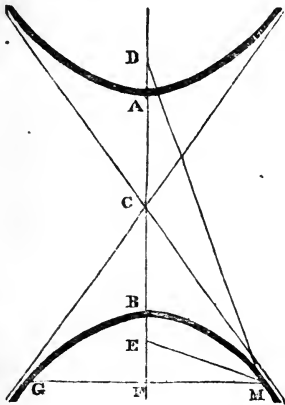

Two points, D and E, in the line of the *axis*, equally distant from either vertex of the hyperbola, are called their *foci*; and these are so situated, that if we take any point, M, in either of the curves, and draw the straight lines M D and M E, the difference of the length of those lines will always be equal to A B, the shortest transverse diameter. Again, any straight line, M F G, in either hyperbola, crossing the axis at right angles, and terminating at both ends in the curve, is a *double ordinate*. M F, F G are *ordinates*, and F B is the *abscissa*.

HYPERBOLIC CONOID, or HYPERBOLOID. A solid formed by the revolution of an hyperbola about its axis.

HYPEROXYMURIATES. The old name for chlorates.

HYPO. In chemistry, under, or an inferior quantity; thus *hyposulphurous acid* contains less oxygen than the *sulphurous acid*, and the *hyposulphuric acid* contains less than the sulphuric.

HYPOTHENUSE. The longest side of a right-angled triangle.

HYPOTHESIS, is generally a proposition or principle which is supposed or taken for granted, in order to draw conclusions for the proof of a point in question. In physics, it denotes a kind of system laid down from our own imagination, whereby to account for some phenomenon or appearance of nature. Thus, we have hypothesis to account for the tides, for gravity, electricity, &c. Hypothesis, in astronomy, is often synonymous with system; thus, we have the Copernican hypothesis, or system.

HYPOTRACHELIUM. The upper extreme end of a column dividing the shaft from the capital. It is only found in the more enriched orders of architecture, where it is an astragal or small round bead, (for figure, see *Astragal*.) The term is generally applied to the Tuscan and Roman Doric orders.



I, the ninth letter and third vowel of our own and of most other European languages, having a soft open sound. It is one of the simplest of characters, being made by a single stroke. It is, in classical words, often interchanged with E; and when two I's follow each other, one was often among the ancients omitted, as *di* for *dii*. As a Roman numeral it signifies 1, and placed before V or X, it diminishes by a unit the number expressed by these two letters.

J is by some persons now considered a distinct letter, but the form of both was originally the same, and it is only within the last century that any distinction was made between them.

IATROPHIC ACID. A name which has been given to the acrid principle of croton oil. Brande has since called it crotonic acid.

ICE. Water in a solid, crystallised state, owing to the abstraction of its latent caloric. Its specific gravity is 92, or rather less than that of water. Water deprived of its air by long boiling, or by being kept a long time in the exhausted receiver of an air pump, and then frozen, forms an ice more hard,

solid, heavy, and transparent than common ice. Ice after it has formed, continues to expand by diminution of temperature.

ICEBERG. The name given to the masses of ice resembling mountains, often found floating in the Polar seas. They are sometimes formed in the sea itself, by the accumulation of ice and snow; at other times they appear glaciers, which have been piling up on shore till quite overgrown, and ultimately broken and cast into the sea by their own weight.

ICE-BEARER. (See *Cryophorus*.)

ICE-BOATS are of two kinds, one of which is a common boat fixed upon a board, which is furnished with irons like skates. It is propelled by the wind impinging upon the sails. The other kind of ice-boat is a heavily laden barge, drawn along a frozen canal by a number of horses, and in its passage breaking through the ice, and thus clearing the navigation.

ICE-HOUSE. A repository for ice during the summer season. In London, ice is preserved usually by fishmongers and confectioners, by placing it on a frame of woodwork in a dry, deep cellar, and covering it over with a thick layer of straw. A large heap of ice may thus be preserved on the surface of the ground, provided the situation be dry, and it be well covered.

ICE-SAW. A large saw used for cutting through the ice, for relieving ships when frozen up.

ICELAND SPAR. A fine variety of crystallised carbonate of lime, remarkable for its clearness, and for the beautiful double refraction which it exhibits. (See *Calcareous Spar*.)

ICHOGRAPHY. In drawing, is synonymous with *plan drawing*, or making the horizontal or perpendicular plan of a building or object, each part of which has its proper relative proportion.

ICONOLOGY. A description of pictures, statues, &c.

ICOSAHEDRON. In geometry, a regular solid, consisting of twenty triangular pyramids, whose vertices meet in the centre of a sphere, which is supposed to surround it, and therefore have their height and bases equal.

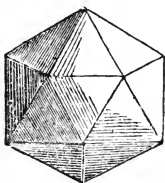

IDRIALINE. The term is applied by Dumas to a native hydrocarbon found in the mercury

mine of Idria, in Carniola, and which appears to be very analogous to naphthaline.

IGASURIC ACID. A name given by Pelletier and Caventou, to an acid which is found combined with strychnia in the *nux vomica*, and in St. Ignatius's bean.

IGNITION. The setting fire to any thing, but more usually limited to the kind of burning which is not accompanied with flame, such as that of metals, stones, and other substances, which become red-hot without melting.

IGNIS FATUUS. A kind of luminous meteor which flits about in the air a little above the surface of the earth, and appears chiefly in marshy places, or near stagnant waters, during the nights of summer. There are many instances of travellers having been decoyed by these lights into bogs, where they perished, and hence the terms *Jack-with-a-Lanthorn*, *Will-with-a-Wisp*; the people ascribing the appearance to the agency of evil spirits, who take this way of alluring men to their destruction. The cause of the phenomenon does not appear to be perfectly understood; it is generally supposed to be produced by the decomposition of animal and vegetable matters, or by the evolution of gases which spontaneously inflame in the atmosphere.

IGNITION. The act of kindling or taking fire; a term opposed to the continued combustion or burning which afterwards ensues.

ILLUMINATING. Enlightening. In the arts, applied to a particular kind of miniature painting, anciently much practised for illustrating and adorning books. Many of the initial letters of this book are taken from the illuminated letters of ancient manuscripts, as A, B, C, and F.

IMAGE. In optics, the appearance of an object made either by reflection or refraction.

IMAGERY. In architecture, painted or carved work.

IMAGINARY QUANTITIES, OR IMPOSSIBLE QUANTITIES, are certain expressions that arise in various algebraical and trigonometrical operations, to which no value either rational or irrational can be assigned; yet being substituted in the equation, whence they were deduced, they are found to answer the conditions of the question.

IMBOW. To arch over; to vault.

IMBOWMENT. An arch or vault.

IMMERSION. In astronomy, denotes the disappearance of any celestial object behind another, or in its shadow. Thus, in the eclipse of one of Jupiter's satellites, the immersion takes place when the satellite disappears behind the body of the planet, or enters into the planet's shadow; and in an occultation of a planet or fixed star by the moon, the immersion is the disappearance of the star or planet behind the body of the

moon. In like manner, the re-appearance of the body is called its emersion.

IMPACT. Striking; in mechanics, the simple or single action of one body upon another, to put the latter, if at rest, in motion; or if it be moving, to increase, retard, or alter the direction of that motion. The point against which the impelling body acts, is called the *point of impact*.

IMPALPABLE POWDERS. Powders so finely levigated that the particles of which they are formed cannot be distinguished by the senses, especially by that of feeling. Fine pigments prepared by a flat stone and muller are in this state.

IMPASTATION. In sculpture, the mixing of different matters, bound together by means of cements, and capable of resisting the action of air or fire.

IMPENETRABILITY. One of the essential properties of matter, whereby is shown the uncontrovertible fact that no two bodies can occupy the same space at precisely the same moment of time.

IMPERFECT NUMBER, is a number the sum of whose aliquot parts is different from the number itself; thus, 12 is an imperfect number, for the sum of its divisors, 1, 2, 3, 4, and 6 is 16, which is greater than 12.

IMPERIAL. A name sometimes given to the Moorish or Saracenic dome, particularly when it tapers towards the top, and is more than ordinarily spread out below. The following is from a Mahometan tomb, at Delhi:—

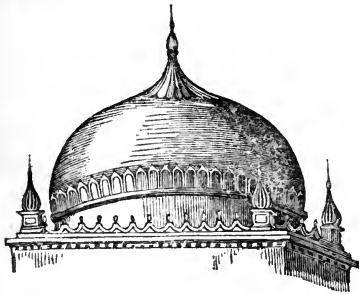

IMPERIAL MEDALS. This name is applied, specifically, in art, to those coins and medals struck after the conclusion of the Roman republican era, and until the fall of the Eastern empire.

IMPERMEABLE. IMPERVIOUS. That cannot be penetrated by fluids; as glass is impervious or impermeable to water, oils, gases, &c. Cloth and other textile fabrics, when rendered water-proof by oiling, tarring, or varnishing them over, are also called impermeable.

IMPETUS. Force, momentum, or motion.

IMPINGE. To strike against obliquely, as one cloud impinges upon another, &c.

IMPONDERABLE MATTER. Some of the substances which surround and affect our globe are of so subtil a nature, that they can neither be confined nor submitted to the usual modes of examination, and are known only in their states of motion, as acting upon our senses, or as producing certain changes in the more gross forms of matter. These have been included under the general term of *radiant, imponderable, or ethereal matter*. Such are light, heat, electricity, and magnetism.

IMPOSING. In printing, is the arrangement of the pages of a sheet upon the imposing stone in their proper order, so that when printed, and the sheet folded, they will follow each other consecutively. It also implies putting the chase and furniture, or wedges, about these pages, and blocking them up ready for printing.

IMPOST. The upper part of a pier or pillar which sustains an arch, or the collection of mouldings under an arch, forming a cornice of small projection, as a finishing to the pier.

IMPRINT. The designation of the place where, by whom, and when a book is printed. When a book consists of more than one sheet, the imprint is put upon the first and last leaf.

IMPRESSION. In painting, means each coat or stratum of color laid on the canvass or other surface, to prepare it to receive finally the colors proper to each object intended to be delineated. It is also sometimes applied to that species of painting of a single color, used upon the wall or wainscot of an apartment, for the purpose of decoration; upon timber or joiner's work to preserve it from humidity; and upon the works of the locksmith to keep them from rust. In printing, the word impression is applied to the copy of an engraving or wood cut, or to the number of a book printed at one time.

IMPROPER FRACTION. (See *Fraction*.)

IMPULSE. A momentary action or force, such as that which arises from the sudden explosion of fired gunpowder, or the momentum of a moving body.

INACCESSIBLE. That which cannot be approached.

INCANDESCENCE. A glowing heat without flame, like that of burning coke.

INCEPTIVE. A word used by Dr. Wallis to express what may be otherwise denominated the principles of magnitude; thus a point is inceptive of a line, a line of a surface, &c.

INCH. A measure of length, supposed to be equal to three grains of barley laid end to end. The twelfth part of a foot.

INCIDENCE, or LINE OF INCIDENCE. In mechanics and optics, is the direction in

which one body presses or strikes upon another.

INCINERATION. The combustion of vegetable or animal substances, for the purpose of obtaining their ashes or fixed residue.

INCIDENT RAY OF LIGHT. In optics, is the line of direction in which a ray is propagated after striking a reflecting body.

INCLINATION. A word frequently used by mathematicians, surveyors, and artizans. The mutual approach of a line and a plane, or of two planes to each other, so as to constitute an angle; thus we speak of the inclination of the side of a hill, the inclination of the sun's rays, &c.

INCLINATION OF MERIDIANS. In dialling, the angle that the hour line on the globe, which is perpendicular to the dial plate, makes with the meridian. *Inclination of the axis of the earth*, is the angle which it makes with the plane of the ecliptic, or the angle between the planes of the equator and ecliptic, which is $23^{\circ} 28'$. *Inclination of the magnetic needle*, the same as dip. *Inclination of a planet*, is an arc or angle comprehended between the ecliptic and the plane of a planet in its orbit.

INCLINED PLANE. A plane or surface which forms an angle with the horizontal plane. It is usually considered as one of the mechanical powers, as the force required to draw a weight up such a plane, and the laws which explain the amount of friction of bodies sliding upon it, are explained by easy mathematical rules, reference being particularly had to the length of the plane, in proportion to its height. The inclined plane is available where the other mechanical powers are deficient in power. There is little doubt but that the amazingly-heavy stones of Stonehenge, of numerous of the Egyptian buildings, pyramids, &c., were raised to their present position by being rolled up long slopes or inclined planes of earth.

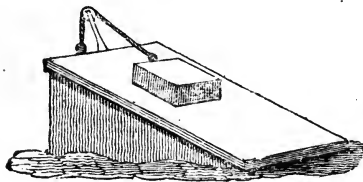

INCLINERS, or INCLINING DIALS, are such as are drawn on planes that are not perpendicular to the horizon.

INCOMBUSTIBLE. That cannot be burned.

INCOMBUSTIBLE CLOTH. (See *Amianthus*.)

INCOMMENSURABLE LINES, are such as have no common measure. The diagonal and side of a square are incommensurable, being to each other as $\sqrt{2}$ to 1, and conse-

quently whatever number of parts the side of the square may be divided into, the hypotenuse will not be made of any exact number of such parts.

INCOMPOSITE NUMBERS. The same as prime numbers.

INCREMENT. In the higher mathematics, denotes a small but finite increase of a variable quantity. It is the difference between two successive values of the function of a quantity, increasing according to a determinate law.

INCRUSTATION. An adherent covering, such as one of lime, calcareous matter, plaster, &c.

INDEFINITE. That which is without any assigned limits; thus, we say an indefinite line, meaning a line of any length. Some authors use the term indefinite nearly in the same sense as we commonly attach to the word infinite.

INDELIBLE. Something that cannot be cancelled or effaced, as indelible ink.

INDELIBLE INK. Ink, which cannot be obliterated by the usual chemical agents, may be made as follows:—Dissolve 25 grains of copal, in powder, in 200 grains of oil of lavender, by the assistance of a gentle heat, and then mix $2\frac{1}{2}$ grains of lamp black, and half a grain of indigo. If too thick, add a little more oil of lavender, or of turpentine.

INDETERMINATE. In mathematics, quantities which change their values are said to be indeterminate, in opposition to those whose values remain fixed and invariable.

INDETERMINATE ANALYSIS. A branch of algebra which has for its object the investigation of problems, which admit of an infinite number of different solutions.

INDEX. A table of contents, a directing point. In mechanism, a light rod, similar to the hand of a clock, which being attached to a graduated scale or dial plate, indicates such alterations as take place. *Index*, in mathematics, the same as exponent. (See *Exponent*.) The *index* or characteristic of a logarithm is the integral part which precedes the logarithm. The *index* of a globe is a small hand fitted to the extremity of the north pole, which turning round with it, points out the time upon the hour circle. In modern globes the index is omitted, the hour circle being moveable around its centre.

INDIA, or INDIAN INK. A preparation manufactured in China, and other parts of Asia, and there used in writing. In Europe this ink is chiefly employed in shadowing drawings. The art of making is supposed to be involved in much mystery, and numerous, even contrary, receipts have been given for its manufacture. Careful experiment shows it to be merely composed of fine lamp black and animal glue, scented with a minute

quantity of musk. Indian ink may be ascertained to be good, by presenting a smooth, glossy fracture when broken, by a total absence of grittiness when rubbed against the front teeth, and by the fractured parts uniting again strongly, after having been wetted by the mouth.

INDIAN RUBBER. (See *Caoutchouc.*)

INDIAN STEEL. (See *Wootz.*)

INDICTION, or ROMAN INDICTION, is a term used for a sort of epoch amongst the Romans, the origin of which is not distinctly known. The Roman indiction consists of a cycle of 15 years, which when expired begins anew, and goes on again in the same order, without any dependence upon the motions of the heavenly bodies. The Popes usually date their acts by the year of indiction.

INDIGO. A drug of a fine, dark blue color, prepared from the leaves and small branches of a low shrub, indigenous to the warmer parts of Asia and Africa. Besides the extensive use of indigo in dyeing, it is of the utmost value both to the oil and water-color draughtsman. It has considerable brilliancy of tone, mixes well, and being, as is believed, more permanent than any other blue color.

INDIGENE. White or deoxydated indigo.

INDIGOTIC ACID. When indigo is acted upon by dilute nitric acid, a peculiar acid was obtained by Chevreul, which has been termed *indigotic acid*. It is white, has the lustre of silk, has a weak, acid, and bitter taste, and unites with the alkalis, and some of the earths and metals, forming indigotates.

INDIVISIBLE. In geometry, are those small elements or principles into which any body or figure may be ultimately resolved.

INDUCTION, is a term used by mathematicians to denote those cases in which the generality of any law, or form, is inferred from observing it to be correct in numerous cases. Such inductions are, however, very deceptive.

INDUCTION, Electrical. The power or influence which an electrified body has over a body not electrified, at some distance from it, the two bodies not touching each other, but yet being within the sphere of mutual influence.

INDUCTION, Magnetic. The influence which a magnetized body has over another near it which is not magnetized.

INDURATING. Hardening, either becoming harder itself, or imparting hardness to others.

INEQUALITY. In astronomy, any deviation of the motion of a planet or satellite from its uniform mean motion.

INERTIA. That tendency which every piece of matter has when at rest to remain at rest; and when in motion to continue that motion.

INFINITE. A term applied to quantities

which are greater than any assignable quantities; also quantities that are less than any assignable quantity are said to be infinitely small.

INFINITE DECIMAL. The same as circulating decimal. (See *Decimal.*)

INFINITESIMAL, or INFINITELY SMALL QUANTITY, is that which is so small as to be incomparable with any finite quantity whatever, or it is that which is less than any assignable quantity.

INFLAMMABLE AIR. Hydrogen gas.

INFLAMMABLE AIR, Heavy. Carburetted hydrogen.

INFLAMMABLE AIR PISTOL. (See *Air Pistol.*)

INFLECTION, called also **DIFFRACTION** and **DEFLECTION,** is a property in light, by reason of which, when it comes within a certain distance of any body, it will be either bent from it, or towards it, which is a kind of imperfect reflection or refraction.

INFLECTION, RETROGRESSION, &c., OF A CURVE, Point of, is a point where the curve begins to bend or turn the contrary way. If the curve, or rather if the two curves form one continued line, the point of union is called the point of *inflection*, as B in A B C. When the one curve turns back upon the other, it is then called the point of *retrogression*, as B in D B E, and in F B G. If the concavity of the two parts lie in the same way, it is called a *ramploid*, as D B E; but if they lie the contrary way, having their convexities towards each other, it is called a *ceratoid*, as F B G.

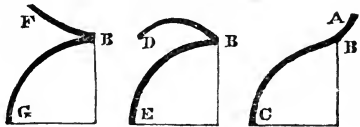

INFORMED STARS. Such stars as are not included in any of the constellations.

INGENHOUSZ'S ELECTRICAL MACHINE. (See *Plate Machine.*)

INGRESS. In astronomy, is the entrance of the sun into any of the signs of the zodiac, particularly Aries.

INJECTION COCK. The cock which admits the cold water into the condenser of a steam engine, to condense the steam within it.

INJECTION ENGINES. Those steam engines in which the steam is condensed by an injection of cold water into the cylinder, as most condensing engines at present in use.

INK. A colored liquid for writing or printing with. According to its composition, color, quality, and purpose for which it is intended, so ink has obtained a great diversity of names; as *Writing Ink, Indian,*

China, or Drawing Ink; Gold, Silver, and other Metallic Inks: Red Ink; Sympathetic Ink; Indelible Ink; Marking Ink; Lithographic Ink; Printing Ink, &c. (See the words in italics for receipts of the various kinds.)

INKING ROLLER. A roller supported on a spindle with handles, used by the printer to supply the types being printed from with ink. It is a wooden roller, from 6 or 8, to 24 or more inches in length, covered with an elastic composition of glue and treacle to hold the ink and bear it properly to the types, (fig. A.) The lithographic printer's roller is a round piece of wood, 4 inches in diameter, turned with a handle at each end, the thicker part being covered with leather, (fig. B.)

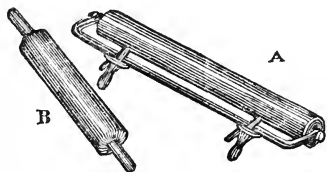

INKING TABLE, or APPARATUS. A table of a peculiar construction, used by the printer, to supply his rollers with a due and uniform supply of ink during the process of printing. It is usually made wholly of cast iron, though many printers prefer that the table should be of a smooth piece of mahogany, believing that such distributes the ink more equally and more readily. A is a flat and perfectly smooth table supported on an iron frame, which may be screwed to the floor, if convenient, though its weight is generally enough to keep it steady. B is a round roller with an iron handle at one end. Behind and under B is a channel to be filled with ink, by lifting up the flap C. D D are weights to regulate the depth into which B shall descend into the channel of ink. B being half immersed in ink, upon turning the handle of B, it offers towards the side A

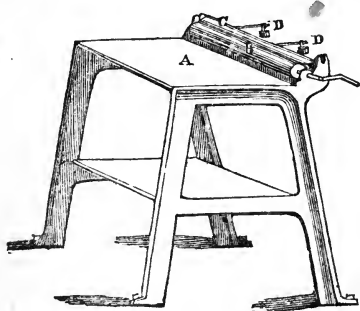

a well-inked surface. The inking roller is rolled against this, and therefore takes up a portion of this ink; when rolling it on the table A it is distributed equally over the whole surface of the roller, and is thus fit to be transferred to the type.

INLAYING. The art of taking away the portion of the surface of a body, and substituting some other more ornamental material. Thus, wood may be inlaid with brass, ivory, and tortoiseshell. Where one substance may be easily rendered soft and pliable, inlaying may be performed by pressing the harder ornamental material into the substance of the other.

INLET. A term applied to an opening into a drain or culvert.

INNER PLATE. The wall plate in a double plated roof, which lies nearest to the centre of the roof; the side of the other wall plate, called the outer plate, being laid in the inner surface of the wall.

INORDINATE PROPORTION, is where the order of the terms is not regular.

INSTANT. An infinitely small and indivisible portion of duration, being with regard to time what a point is in respect to magnitude.

INTAGLIO. In sculpture and gem sculpture, a stone in which the subject is hollowed out, so that an impression from it would present the appearance of a bas relief.

INSCRIBED, or INSCRIBED FIGURE. A figure is so called when placed within another figure or solid, so that all its angles may touch either the angles or sides of it, or both. In the following cut the circle is inscribed in the triangle:—

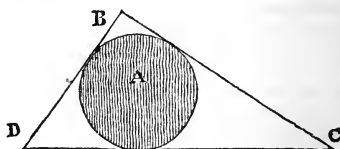

INSERTED COLUMN. One that is let into a wall.

INSULATION. In electricity when a body is so supported and surrounded with non-conducting substances, that it cannot readily part with the portion of electric fluid communicated to it, it is said to be insulated.

INSULATED COLUMN. A column that stands quite clear from a wall, so that it may be seen all round.

INTEGER. Integral, or whole number, is a unit or an assemblage of units, as 4, 16, 784. Used in distinction to a fraction or part of a number.

INTEGRAL CALCULUS, is the reverse of the differential calculus, and corresponds with the inverse method of fluxions; the finding of an integral to a given differential,

being the same as finding the fluent of a given fluxion, and is performed by the same rules.

INTEGRANT PARTS OF A BODY. The small atoms, particles, or molecules, of which any body or substance is composed. Thus, if a body be mechanically divided, pounded, or ground, the fine powder resulting will be its integrant parts.

INTENSITY. The power or energy of any quality or action of a body; thus, we say, intensity of heat or cold, intensity of a blow, &c.

INTERCALARY DAY. The extra day which is inserted into the calendar every fourth year, to compensate for the odd hours and minutes of the solar year, which consists of 365 days, 5 hours, 48 minutes, and 57 seconds. An intercalary day in every four years being however rather too much to make up the deficiency of the odd hours and minutes, the intercalary day is omitted three times in four centuries, which renders the calculation of time extremely accurate. (See *Leap Year*.)

INTERCEPTED AXIS. In the conic sections the same as absciss. (See *Hyperbola*.)

INTERCOLUMNIATION. The space between columns. It is of five different kinds, known by the terms *Picnostyle*, *Systyle*, *Eustyle*, *Diastyle*, and *Aræostyle*, (which see.)

INTERDENTILS. The space between dentils.

INTERFERENCE OF LIGHT. A term first employed by Dr. Young to express certain phenomena, which result from the mutual action of the rays of light on each other. The phenomena may be thus explained:—Suppose two minute pencils of light, radiating from two different luminous points, to fall on the same spot of a screen, or piece of paper, and making a small angle with each other. If the spot on which both pencils fall is at the same distance from both foci, or luminous points, the intensity of the illumination is greater than would have been produced by either pencil alone. Now it has been found that there is a certain difference between the lengths of the paths, at which the intensity of illumination produced by their concurrence is the same as when the paths are equal. Call this difference d , then it is also found by experience that similar bright bands or fringes are produced, when the difference between the lengths of the paths of the two pencils is $2d$, or $3d$, or $4d$; but it is very remarkable, that when the difference between the lengths of the paths is $\frac{1}{2}d$, $1\frac{1}{2}d$, or $2\frac{1}{2}d$, the two pencils instead of adding to each other's intensity destroy each other, and produce a black spot or fringe. The two pencils thus act on each other, increasing the effect in one case and diminishing it in another, and it is this mutual action which is called *interference*.

INTERIOR ANGLE. (See *Angle*.)

INTERIOR ANGLE OF A POLYGON. That

which is formed internally by the meeting of any of the sides of the figure.

INTERJOIST. The space between one joist and another; this is, according to the quality of the house, from 10 to 20 inches.

INTERMEDIATE SPACE. On railroads, is the centre space or distance between each line of rails or double lines of railway. This varies on different lines. It is frequently made the same as the distance between the rails, or 4 feet 8½ inches, although it is increased to 6 feet on the London and Birmingham and other railroads.

INTERMITTING. Any thing so irregular in its action as to act and then apparently cease to act, and so on alternately and spontaneously.

INTERMITTING OR INTERMITTENT SPRING.

A spring of water which stops and flows alternately. Suppose the figure below to represent a hill which has within it a cavity, A. This, supposed at first to be void of water, becomes filled by the water of the rains and land springs trickling through the various crannies of the hill. When so filled as to be at a level in A, equal to the bent channel or pipe B, it will flow away by B into C, B acting like a syphon and drawing off all the water in a continued stream. When drawn off, the flow of course ceases, and A begins to fill again, and when sufficiently full, the same action goes on a second time as at first, and the spring is intermittent.

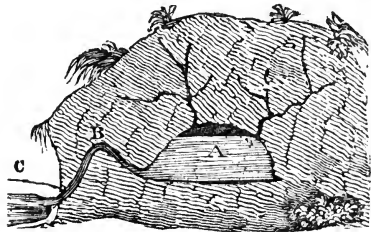

INTERMODILLION. The space between modillions.

INTERPOLATION. A branch of the mathematics which teaches to find any intermediate term in a series; its place or distance from the first term being given.

INTERSECTION. The cutting of one line or plane by another; the point or line in which they meet being called the point or line of intersection.

INTERSTELLAR. A term used by some old authors to denote those parts of space which are beyond the regions of the solar system.

INVERSE PROPORTION. (See *Proportion*.)

INTERTIES. Horizontal pieces of timber, placed between upright posts to tie or bind them together.

INTRADOS. The interior curve of an arch.

INORGANIC CHEMISTRY. That part of chemistry which relates to inorganic matters, including all the materials of the mineral kingdom; the account of those substances arising from animal and vegetable organization, constituting organic chemistry.

INULINE. A starch-like substance, extracted from the root of the *inula helenium*, or *elecampane*.

INVERSE METHOD OF FLUXIONS. The method of finding the *fluents* of given fluxional expressions, the same as the integral calculus.

INVERSE METHOD OF TANGENTS, is the method of finding a curve belonging to a given tangent; being thus distinguished from the direct method, or that of finding the tangent from the properties of the curve.

INVERSION. The inverting the terms of a proportion :

Thus if $a : b :: c : d$.

Then by inversion .. $b : a :: d : c$.

INVERTED ARCH. Such as has its concavity below the centre or axis. It is useful in every part of a wall which is lower than the two adjacent parts, or where an interruption is made by an aperture near its base ;

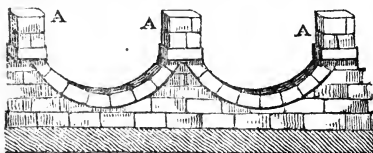

and particularly where the base of a building contains many breaks or openings, it is necessary to introduce inverted arches in the foundations to distribute the weight of particular points, such as of the piers, A A A, over the whole extent of the foundation, that the pressure may be equal throughout.

INVISIBLE GIRL. A particular instrument in acoustics, often made the subject of public exhibition, from which a weak girlish voice appears to issue, in answer to questions submitted to it by speaking opposite to either of the four trumpets of the instrument. It is formed as follows :—

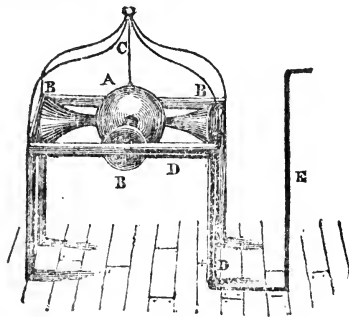

A square mahogany frame stands upon the floor, supported upon four legs, each of which legs has a strong wire at top, so leaning and meeting over the centre of the frame as to support by a string C a large brass ball A, having four trumpet or funnel-shaped parts attached one to each side of it, (three of these are seen at B B B,) the narrower ends opening into the ball, the wider ends being close to the sides or rails of the frame. Opposite one of the trumpets is a small hole in the frame, leading to a hollow pipe D contained in the top of the frame and down one leg of it, hence along the floor to another apartment, supposed at E. When a person speaks at the mouth of one of the trumpets, the voice enters the globe; here it is reverberated or echoed, a part proceeding out of each of the trumpets. This is too weak to be heard by the by-standers, but the sound from one trumpet enters the small hole of the frame, this being exactly the focus of it. It passes along the pipe, and is distinctly heard by a person whose ear is at the farthest end of the pipe, who returns an answer, which is distinctly heard by any person opposite to either trumpet.

INVOLUTE CURVE, is that which is traced out by the extremity of a thread as it is folded or wrapped about another figure or curve; the contrary to *Evolvute*, (which see.)

INVOLUTION. In arithmetic and algebra, is the raising of a given number or quantity to any proposed power. This consists merely in multiplying the number by itself the requisite number of times; thus, the fifth power of 2 is $2 \times 2 \times 2 \times 2 \times 2 = 32$.

IN VACUO. Empty space, or a place from whence the atmospheric air is excluded; as, for example, the exhausted receiver of the air pump.

IODATES. Compounds of iodic acid. (See *Iodine*.)

IODIC ACID. (See *Iodine*.)

IODIDES. (See *Iodine*.)

IODINE. A peculiar undecomposed principle, discovered in 1812 among the ashes of sea weeds. Its specific gravity is about 4. It becomes a violet-colored gas at a temperature below that of boiling water. It combines with the metals, forming a class of compounds, called *iodides*; with oxygen it forms the *iodic acid*; with hydrogen the *hydriodic acid*. It is a most delicate test for starch in solution, tinging of a blue color water containing only a 400000 part of starch in cold solution.

IDO-SULPHURIC ACID. When sulphuric acid is dropped into a concentrated and hot solution of iodic acid, crystals form, which have been termed iodo-sulphuric acid.

IOUOUS ACID. A peculiar compound of iodine and oxygen.

IONIC. The third order of Grecian archi-

ecture, intermediate between the strong Doric and the delicate Corinthian. The height of the columns is 9 diameters; the capital is adorned with volutes or scrolls, and the cornice with brocks or dentiles.

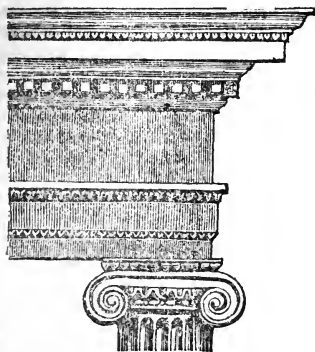

IONS. The elements into which any body is separated when subjected to electrolysis; that is, to electro-chemical decomposition. For example, when water is thus electrolysed, it is resolved into its two elements, oxygen and hydrogen, these therefore are called *ions*, that which is evolved at the anode, namely, oxygen being therefore an anion—while hydrogen being evolved at the cathode is called a cathion.

IRIDIO - CHLORIDES. Particular salts formed by the union of the chlorides of iridium with certain bases; very little is known respecting them.

IRIDIUM. A metal discovered by Dr. Wollaston, associated with certain ores of platinum. It is grey, brittle, very infusible, and of a specific gravity of about 18.6. It forms several oxides and chlorides, and combines readily with carbon.

IRIS. The name of the rainbow. (See *Rainbow*.)

IRIS ORNAMENTS. (See *Barton*.)

IRON. A well-known metal, of a grey color, possessing when polished much lustre. It is malleable, ductile, and tenacious; at common temperatures, hard and unyielding; but at a red heat soft and pliable. It is very difficult of fusion, is attracted by the magnet, and capable of being itself rendered magnetic; a property possessed by no other metal, except nickel. It has never been found *native*; that is, in its pure metallic state, except in the form of *meteoric iron*. It is abundantly mixed with oxygen, sulphur, and occasionally other substances. There are known in commerce two sorts of iron, *cast iron* and *wrought iron*. The former being distinguished, according to its quality, by the terms *white* and *grey*; of these the

first is the hardest. Iron united with carbon forms *plumbago* and *steel*; united with various earths and oxygen, it constitutes the different *ochres*, &c. It unites with numerous of the other metals, forming valuable alloys, and is soluble in most of the acids.

IRON PYRITES. Yellow sulphuret of iron, composed of iron 23, and sulphur 32 parts. It is a very abundant ore of iron.

IRON SMELTING FURNACE. (See *Blast Furnace*.)

IRRATIONAL NUMBER. (See *Surd*.)

ISAGONE. An old mathematical word denoting a geometrical figure with equal angles.

ISINGLASS. A substance procured from different kind of fish. It is almost wholly pure gelatine, ninety-eight parts out of every hundred of good isinglass dissolving in water. It forms a nutritious jelly when boiled, and is in much request by confectioners and others. Brandy added to the strong watery solution renders it less liable to decay, and forms it into a strong glue or cement, which has been much used for joining china, glass, &c. It will not, however, bear hot water.

ISOCROMATIC. Having the same colors: said of certain crystals, when the rings of polarized light shown by the one agree in tint and color with the rings formed by the other crystal.

ISOCRONAL. ISOCRONOUS. Of equal duration, like the vibrations of a pendulum.

ISOCRONAL LINES, are those along which a heavy body descends with a uniform velocity.

ISOMERISM. Compounds which contain the same elements in the same ratio, and yet exhibit distinct chemical properties, are said to be *isomeric*. Thus, the cyanic and fulminic acids are isomeric compounds of nitrogen, oxygen, and carbon.

ISOMORPHOUS. Substances which resemble each other in their crystalline forms, but differ in their component parts, such as the phosphate of soda and the arseniate of soda.

ISOPERIMETRICAL FIGURES. In geometry, are those which have equal perimeters or bounding lines.

ISOPERIMETRY. A branch of geometry which treats of the properties of isoperimetric figures, viz.: of surfaces contained under equal perimeters; of solids under equal surfaces; of curves of equal lengths, &c.

ISOTHERMAL. ISOTHERAL. ISOCHIMENAL. Isothermal *lines*, are those which pass through those parts of the earth's surface at which the mean annual temperature is the same. Isothermal *zones* are spaces on opposite sides of the equator, having the same mean temperature and bounded by correspondent isothermal lines. On account of the irregular form and disposition of the

continental masses, by which the climate of different places is greatly influenced, the isothermal lines are not parallel to the equator, except in the very low latitudes. Humboldt gives the name of *isothermal* lines to the curves passing through those places at which the mean summer heat is the same; and of *isochimnal* to those which pass through the places at which the mean temperature of winter is the same.

IVORY. The tusk or tooth of defence of the male elephant. It is an intermediate substance between bone and horn. The entire tooth is of a brownish yellowish color on the outside, internally white, solid near the point, and hollow towards the root. The grand consumption is for making ornamental utensils, mathematical instruments, cases, boxes, balls, combs, dice, and an infinity of toys. Boiling it in cochineal stains it red; in verdigris, green; in French berries, yellow; in sulphate of indigo, blue; and in common ink, black.

IVORY BLACK. An animal charcoal produced by burning ivory in close vessels; like the other forms of animal charcoal, it is very effective in depriving certain substances of a bad odour and color. It is a valuable pigment for the artist, both ground in oil and water, forming a color of a good body, which dries better than lamp black, and is pleasant to work.

IVORY, Etching on. Cover the surface of the ivory with a ground made of the following ingredients, melted together:—Pure white wax, 1 oz.; transparent tears of mastic, 1 oz.; asphaltum, $\frac{1}{2}$ an ounce. This compound is to be poured in luke-warm water, kneaded into a ball, and wrapped in taffety. The ivory being warmed, the ball of etching ground is to be rubbed on it. The figured design traced on this with a needle, a ledge of wax put round it, and the surface then etched or eaten away with strong sulphuric acid. Simple white wax will answer instead of the above prepared ground, and hydrochloric acid instead of the sulphuric.

JACK. In mechanics, an instrument for raising heavy weights. There are several kinds; one of which, the *Common Hand Jack*, is represented, where it is shown in perspective and in section. A block of wood, about 2 feet 6 inches long, 10 inches broad, and 6 inches wide, is perforated with a square hole or mortice through it, lengthwise, for the reception of an iron rack B. This rack is formed with a double claw or horn at its upper end. A small pinion is made to work in the teeth of the rack. The axis of the pinion is supported in iron plates, bolted on each side of the block, and one end of the axis projects through the side plate, with a square to receive a winch or handle, which upon being turned, the pinion

elevates the rack, and raises up the claw to meet the work. To prevent the weight of the load running the pinion back, the rack is detained by a hook or link C, fastened to the outside of the block. When a greater power is required, it is necessary to use a second wheel and pinion, as represented in the same figure, where H is the handle. G the first pinion working a wheel; that a second pinion, and that second pinion the rack B. The lower part of the rack is often furnished with a second pair of horns or claws, as at N, which projects sideways from the block.

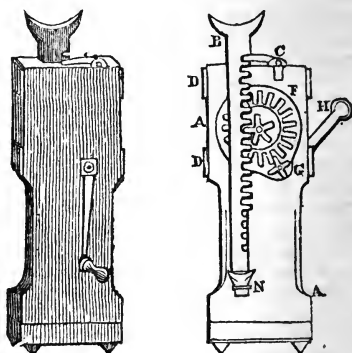

JACK TIMBERS. Those in a row of timbers which being intercepted by some other piece are shorter than the rest. Thus in a hipped roof those rafters which are shorter than the side rafters are called jack rafters.

JACKS, Wooden wedges, used in coal mines to split the rocks asunder after blasting.

JACKET, STEAM. The cylinders of steam engines, of a large size, are usually encircled with other cylinders of greater diameter; steam being introduced between them, in order that the inner cylinder may be kept warm. This envelope or outer cylinder is called a *jacket*.

JACOB'S LADDER. A rope ladder, with wooden steps or spokes.

JACOB'S STAFF. The same as *Cross Staff*, (which see.)

JALAPIN. The supposed base of jalap.

JAMBS. The sides of a door, window, fire place, or other opening.

JAPAN COPPER. Copper cast into small ingots for exportation, chiefly to the East Indies. The copper is dropped from the moulds immediately upon becoming solid into cold water, by which the ingots acquire externally a deep red color. It differs, however, in no respect from common copper.

JAPAN INK. A superior kind of writing ink, so called from its better color and lustre. To make it:—Take 8 oz. of Aleppo

galls, 4 oz. of logwood, 4 oz. of sulphate of iron, 3 oz. of gum arabic, 1 oz. of sulphate of copper, and 1 oz. of sugar candy. To be boiled in 8 pints of water till reduced to 6 pints.

JAPANNING. The art of covering wood, paper, or metal, with a thick coat of a hard, brilliant varnish. It originated in Japan, whence articles so prepared were first brought to Europe. The material, if of wood, or papier machée, is first sized, then covered with several coats of hard copal varnish; each of the latter coats being polished with putty powder and water, previous to laying on the next. Metal work and numerous other articles have but one or two coats laid upon them, and these are dried by the heat of a stove or oven.

JAR, Electrical. (See *Leyden Jar*.)

JARGON, or ZIRCON. A precious stone so called.

JASPER. A siliceous mineral, of various colors, sometimes spotted, banded, or variegated. It takes a fine color, and the variety and richness of its colors render it useful in the ornamental arts. The blood stone is a variety of it.

JELLY. (See *Gelatine*.)

JERKIN HEAD. The end of a roof that is not hipped, down to the level of the opposite adjoining walls; the gable being carried higher than the level of the said walls.

JET. A bituminous carbon; some varieties admit of a brilliant polish, and are used for ornamental purposes.

JET. In the casting of statues this word is used to denominate the channels by which the metal, in a state of fusion, is introduced into the mould.

JET, Condensing. The water used for condensing the steam in ordinary steam engines is introduced into the condenser through a rose or vessel, at the end of the injection pipe, which is perforated with a great number of small holes, so that the water enters the condenser in a shower, and thus exposes the greatest possible extent of surface to the steam, in order to ensure rapidity of condensation.

JET D'EAU. (See *Fountain*.)

JETTE. In the construction of bridges the same as starling.

JIB. The projecting beam or arm of a crane.

JIB DOOR. A door made without dressings or mouldings, so as to be flush with both sides of a wainscot, and to appear as a part of it; the intention being to conceal even the appearance of a door.

JOGGLE. A mason's term to signify the jointing of one stone into another, in such a manner that they cannot slip away from each other, without tearing the joint or *joggle* asunder. A separate piece of hard stone, called a *joggle*, is sometimes introduced at

joints of stones exposed to great strains, thus:—

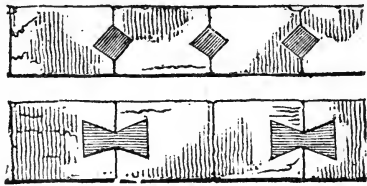

JOGGLE PIECE. A truss post, whose shoulders and sockets receive the lower ends of the struts.

JOINERY. The art of framing, fitting, and finishing off the wood-work in the interior of houses; also windows and doors. Joinery is distinct from carpentry, which is fitting up the rough timbering, used in the first construction of the walls, roof, floors, &c.

JOINT. The place where two parts of a machine, frame-work, &c., are joined together.

JOINT, Universal. (See *Hooke*.)

JOINT CHAIR. The chair which secures the juncture of two railway bars together.

JOISTS. Timbers placed parallel to and equally distant from each other to support the boards of a floor.

JONES'S HYGROMETER, consists of a delicate mercurial thermometer, with its tube

at A bent so as to bring its cylindrical ball C parallel with and at a little distance from the stem. The bulb is an inch long, and is terminated by a flattened surface D of black glass, which projects a little beyond the sides of the bulb. The bulb below the blackened surface is covered with black silk. The instrument is supported on the wire E F, which is attached to the scale by a pivot that allows the black surface to be inclined to the light, and the whole, with a

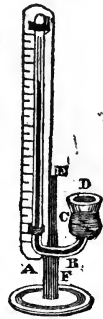

phial of ether, are inclosed in a small case. When used, the temperature of the air is first noted, then ether is poured on the silk cover of the bulb, and the condensation of the dew is seen on the black extremity of the bulb.

JULIAN ÆRA. The commencement of a period, invented to correspond with the cycles of the Julian year. It coincides with the 710th year before the creation of the world, according to common chronology.

JULIAN CALENDAR. The civil calendar introduced at Rome by Julius Cæsar, and used by all the Christian countries till it was reformed by Pope Gregory XIII, in 1582.

By it the year was to consist of 365½ days; and the vernal equinox, the time of which had previously been much disturbed, was again restored to the 25th of March.

JULIAN EPOCH. In chronology, the epoch or commencement of the Julian calendar. The first Julian year commenced with the 1st of January of the 46th year before the birth of Christ, and the 708th from the foundation of Rome.

JULIAN PERIOD. In chronology, is a period consisting of 7980 Julian years. The number, 7980, is formed by the continual multiplication of the three numbers, 28, 19, and 15; that is the cycle of the sun, the cycle of the moon, and the cycle of indiction. The first year of the Christian era had 10 for its number in the cycle of the sun; 2 in the cycle of the moon; and 4 in the indiction. Now, the only number, less than 7980, which on being divided successively by 28, 19, and 15, leaves the respective remainders, 10, 2, and 4, is 4714; hence the first year of the Christian era corresponded with the year 4714 of the Julian period.

JUMP. One of the numerous appellations given by miners to a fault or dislocation of different mineral strata.

JUNIPER BERRIES. The fruit of the juniper tree, used to flavor gin and hollands.

JUNO. One of the four asteroids or small planets, situated between the orbits of Mars and Jupiter. It resembles a star of the eighth magnitude, is of rather a reddish color and without nebulosity. Its diameter, in English miles, is 1425. Its mean distance from the sun is 253,000,000 of miles, and it rotates on its axis in 27 hours. Its annual revolution around the sun is 4 years, 128 days, and it is supposed to have an atmosphere more dense than any of the older planets.

JUPITER. The largest planet of our system, and the fifth in order from the sun, with regard to the old planets; but the ninth, including the four new planets, lately discovered between him and Mars. Jupiter is attended by four satellites or moons. This planet is remarkable for the faint appearance of belts or stripes with which he is surrounded. (See *Belt*.) Jupiter is brighter in appearance than any other planet, except Venus. He performs his sidereal revolution in nearly 12 years, and turns on his axis in 9 hours, 55 minutes, and 49 seconds. His diameter is 91,522 miles, and consequently he is 1331 times larger than the earth. His mean distance from the sun is nearly 490 millions of miles.

JUT, or JUTTY. Any projecting part of a building.

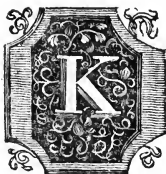

A consonant letter, belonging to most ancient and modern languages. It has a hard sound before all the vowels, as in *kali, keep, kirk, koran, kufic*. It is silent before *n*, as in *knoll, knight*.

In Latin, K occurs only in a few words, though often used in abbreviations instead of C. In French, it is also a letter of rare occurrence.

KALEIDOSCOPE. An instrument for creating and exhibiting an infinite variety of beautiful forms. This instrument, the invention of Dr. Brewster, in its most convenient form, consists of a tin or brass tube, 6 or 8 inches long, containing two reflecting surfaces, inclined to each other, at any angle which is an aliquot part of 360°. The reflecting surfaces may be two plates of glass, blackened at the back or quicksilvered, or else two metallic surfaces. The two ends being now closed, except a small round hole at one end to look through, and a ground glass plate at the other; when the eye looks through the hole, it will perceive a circle of light, divided into as many segments as the number of times that the angle of the reflectors

is contained in 360°. If now any objects be inclosed in a transparent box, at the opposite end of the instrument, they will be multiplied according to the number of reflections, and the images of them arrayed in the most symmetrical manner, ever varying according as the position of the tube is altered. The objects used are mostly bits of colored glass, lace, beads, &c.

KALIUM. Synonymous with potassium.

KALI. The old name of potass.

KAOLIN. The Chinese name of porcelain clay. The same clay found in other places, as in Cornwall, is called by the same Chinese name.

KATER'S AZIMUTH COMPASS. A B is a brass cylindrical box containing the compass, of which the card D is 5 inches in diameter. The needle which is perforated in its centre to admit an agate cap, set in brass for the purpose of suspension, is fixed to a circular piece of talc, over the circumference of which a narrow circular ring of card is laid; the outer margin of this card is accurately graduated into half degrees. The breadth of the cylindrical box is exactly 1 inch, and it is covered, as usual, with a piece of glass. A slanting piece of ivory C is fixed to one side of the box, so as just to come over the

outer edge of the graduated circle of the card; a line at right angles to the circumference of this circle is marked upon the ivory to serve as an index for reading off the degrees. To the opposite side of the box, at O, a sight is affixed, consisting of a brass frame in the form of a parallelogram, 5 inches long. To this frame is adapted a shorter frame E F, 2 inches in length, which slides upon it, and carries the segment of a glass cylinder, ground to a radius of 5 inches. By means of this piece of glass, when presented to the sun, the rays are collected into a linear focus, the line of light being thrown on the index on the piece of ivory, which may be seen at the same time as the degrees on the card. The sight has a hinge where it is connected with the box, by means of which it can be folded down upon the glass cover of the box.

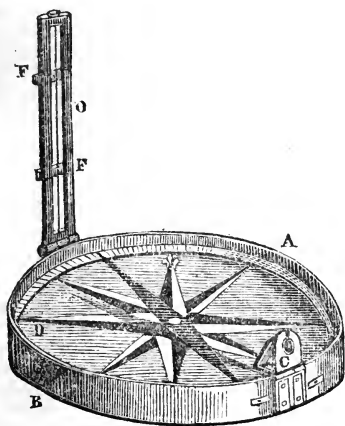

KEDRIA TERRESTRIS. Barbadoes tar; a species of bitumen.

KEEP. The principal and strongest tower of a castle, intended as a last resource in case of attack. The round tower of Windsor Castle is of this kind.

KEEPING. In painting, a term which signifies the peculiar management of those parts of the art, coloring and chiaro-scuro, which produces the proper degree of relief in objects admitted into a composition, according to their relative positions in the imagined scene, and the degree of importance the artist attaches to them.

KELP. A general name for the common sea weeds, from which soda is procured. These are *Fucus bulbosus*, *serratus*, *nodosus*, &c., *Laminaria*, and others. The sea weeds after they are burnt are also called *kelp*, being then an impure carbonate of soda, mixed with much ashes.

KEITH'S REGISTER THERMOMETER. AB is a glass tube, 14 inches long, and $\frac{3}{4}$ inch diameter, sealed at the top, and below communicating with the bent tube BD, 7 inches long and 0.4 inches in diameter, open at the top, where it is cemented to a metallic plate E, which supports the ivory scale F, $6\frac{1}{2}$ inches long. From A to B, the tube is filled with highly-rectified spirits of wine, and from B to C with mercury. At C is a conical float of ivory or glass, resting on the surface of the mercury, and supporting a kneed wire H, intended for moving two indices of black silk I and K, that slide along a fine gold wire G K placed to receive them. It is obvious, that as the heat alters the dimensions of the column of spirit in AB, the mercury will rise or fall in the small tube, and the float swimming on the surface of the mercury will raise or depress the wire H, which will move the indices I and K. The instrument is defended from winds and rain by the glass case L L, which by means of its metal collar fits tight on E, and is only removed to adjust the indices.

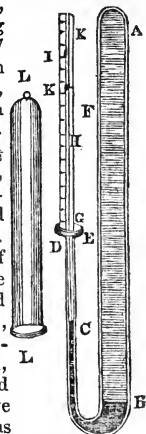

KEPLER'S LAWS. In astronomy, are the laws of the planetary motions, first discovered and demonstrated by Kepler, and which form the basis of the whole theory of gravitation and physical astronomy. They are three:—First, that the planets describe ellipses, each of which has one of its foci in the same point; namely, the centre of the sun. Second, that every planet moves so that the line drawn from it to the sun, describes about the sun areas proportional to the times. Third, that the squares of the times of the revolutions of the planets are as the cubes of their mean distances from the sun.

KERAMOS. In modelling and sculpture, earth which is tenacious and malleable when moist, but hardens on exposure to the sun or fire. It is used in the construction of vases, bas reliefs, cornices, &c., as well as that of bricks and tiles, and indeed all works the substance of which is commonly distinguished by the term *terra cotta*.

KERF. A word used by sawyers to signify a saw cut, or the channel cut by the saw through wood, &c.

KERMES. An insect found in many parts of Asia and the south of Europe, inhabiting certain species of the oak. On account of their round figure, they were for a long time taken for the seeds of the tree on which they

live, whence they were called *grains of kermes*. They are used to dye wool of a scarlet color, though the color is far inferior to that produced by cochineal.

KERMES, Mineral. Hydro-sulphuret of antimony.

KERSEY. KERSEYMERE. *Kersey* is a kind of coarse cloth, usually ribbed and woven from long wool. It is manufactured chiefly in the north of England. *Kerseymere*, on the other hand, is a thin stuff, generally woven plain from the finest wools. It is principally made in the western districts.

KEWLEY'S THERMOMETER. (See *Balance Thermometer*.)

KEY, Cottar, or Cottrel. A wedge-shaped or tapering piece of iron or wood, which is driven firmly into a mortice prepared to receive the same, to tighten and secure the several parts of any framing or contrivance together, thereby forming a fastening. When a key is passed through a timber beam, or two or more pieces of metal placed side by side, it is customary to clasp them together by irons, called *gibs*, previous to inserting the keys; as in the cut B B B B are the gibbs, and A A the keys.

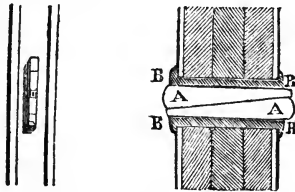

KEYS. In naked flooring, pieces of timber framed in between every two joists by mortice and tenon, and when driven fast between each pair, with their ends butting against the grain of the joists, are called *strutting pieces*. *Keys* in joinery are pieces of timber let into the back of a board, which is made of two or more separate breadths of timber, for the purpose of preventing warping of the whole.

KEYS OF A FLOOR. The last board, or the last two boards that are laid.

KEY BOARD. The series of levers in a keyed instrument, as a piano-forte or organ, upon which the fingers press to produce percussion of the strings, or in the organ the opening of valves. It consists of short black and long white keys.

KEY SCREW. A lever used for turning screws.

KEY STONE. The central stone on the crown of an arch, binding the whole together. Sometimes all the stones forming the circular part of the arch are called key stones.

KILN. A stove or oven intended to dry various substances, such as malt and other

grain, hops, &c. It also signifies a fabric or building, constructed for the purpose of burning limestone, chalk, and other calcareous stones into lime. A clamp of bricks burnt or ready for burning is likewise called a kiln.

KINATES. Combinations of the kinic acid,

KING POST. The central post of a framed roof, reaching from the centre of the tie beam to the ridge at top. (See *Roof*.)

KING'S YELLOW. A pigment of a pale yellow color, the basis of which is orpiment or the yellow sulphuret of arsenic.

KINK, or KINKLE. The entangling of cordage from overtwinning.

KINIC ACID. Synonymous with cinchonic acid; an acid discovered in Jesuit's bark.

KINNERSLEY'S ELECTRICAL AIR THERMOMETER, is an instrument to show that

the air is dilated when it is made the passage of the electrical discharge. F is a glass tube, on each end of which a brass cap is cemented. B A is a small glass tube open at both ends, which passes through the upper and descends nearly to the under plate; a box-wood scale, which is divided into inches and tenths, is fitted to the upper part of this tube. F is a brass wire, with a ball on it, which is screwed to the under plate; a similar wire is made to pass through a collar of leathers on the upper plate, and may be placed at any convenient distance from the lower ball. The glass tube A dips into mercury, or a colored fluid. Whenever a spark passes from the one ball to the other, the air within is dilated, and the mercury or colored fluid rises in the glass tube. When the spark or shock has passed it immediately returns to its first condition.

KINO. An extractive matter obtained from the *nauclea gambir*, a shrub which grows in Sumatra and elsewhere. It is of a reddish brown color, has a bitter styptic taste, and consists chiefly of tannin. Kino is often called a gum, but improperly so.

KITE, Electrical. An instrument very similar to a common kite, invented by Dr. Franklin to bring lightning from the clouds, and thereby to prove the identity between lightning and the electric fluid. It is best made of a large silk handkerchief, having placed across the back of it, from corner to corner, two strips of light wood. The loop to which the string is attached is made in the usual manner. To one end of the kite is

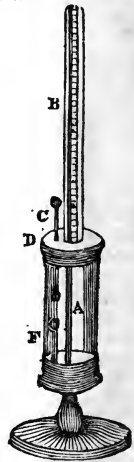

fastened to the tail; to the opposite end or head are fastened two or three fine pointed wires, similar to a toasting fork, which project somewhat beyond the kite above, and are twisted partly down the loop so as to join the string, which should have a fine wire inserted in it throughout the whole length. When in use, the end of the string near the ground is to be attached to a dry silk cord, or ribbon, and a key or other piece of metal fastened at the juncture of the string and silk. Should there be lightning in the air, and there mostly is both in summer and winter, it will be attracted by the points on the top of the kite, flow down the string, and finally pass out at the key to the ground.

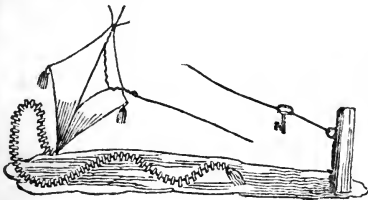

KNEE. A piece of timber or metal, cut or cast so that one part shall form an angle with the adjoining side.

KNIGHT'S ASSAY LAMP. Such is the name given by Mr. Knight, Foster Lane, to an extremely useful Argand lamp, adapted to heat retorts, and for general chemical purposes. A is a flat short cylindrical vessel, for containing the oil. B is a double cylinder of tin, about an inch in diameter. The outer cylinder passes through, and is soldered air-tight to the oil vessel; the inner cylinder passes from the holes below to the centre of the flame.

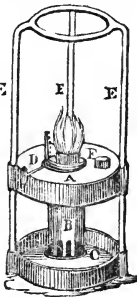

The oil and the cotton pass between the two cylinders. B is furnished with a screw below, which screws on to the foot C. D is a rack and pinion to regulate the height of the wick. E E E are three wires, formed into a frame-work to support any thing which is to be heated; these wires slide up and down in sockets on the sides of A and C. F is a hole for the supply of oil. There is usually a copper tube placed over the flame, in the manner of a lamp glass, to concentrate the heat by preventing its radiation sideways.

KNIGHT'S BLOW-PIPE APPARATUS. This instrument is of French invention, and in travelling of considerable utility, being compact and easy to manage. A is an air-tight

bladder of silk or India rubber. B a clamp to fasten the same to a table; B is perforated from C to A, and also to the jet D, but there is a valve opening downwards at the lower end of the tube C. When to be used, the operator is to blow into C until A is full of air; then pressing A with the knee, (supposing him seated in front of the instrument,) the air rushes out of the jet D, on to the lamp flame E, which it urges to a point in which the substance to be operated upon is to be held. Blowing occasionally into C renews the supply of air to the bladder.

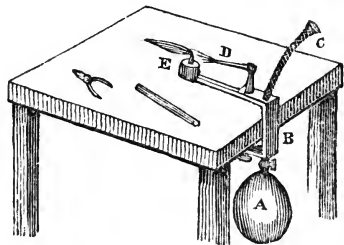

KNIGHT'S CHEMICAL FURNACE, is one of simple construction and of general application. It is represented as follows:—

A is the ash-hole door. B the fire-place door in which muffles, crucibles, &c. are to be introduced. C a door above the fire for introducing retorts. The top also may be wholly removed to insert a still or sand bath. DE are doors of different heights, leading to the fire, for the more convenient introduction of different apparatus. F the hole for the introduction of a gun barrel. G and H handles, by which the whole furnace may be removed.

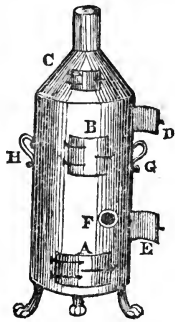

KNIGHT'S METHOD OF MAKING MAGNETS, consists in employing two magnets in the same operation, applying two dissimilar poles of these magnets, each to a different half of the bar to be impregnated, and confining its action to that portion of the bar.



For this purpose, the two magnets are to be joined lengthwise, with their dissimilar poles in contact, and laid on the bar to be magnetized, in the manner represented in the figure, where A and B are the magnets, and

C the bar to be magnetized, so that the point of junction of the magnets shall be immediately over the centre of the bar. Then separating the magnets, by drawing them opposite ways, in the direction of their length as far as the extremities of the small bar; they are next to be removed to a considerable distance and again joined, and afterwards laid a second time in the centre of the bar, in the same manner as at first. This operation is to be repeated several times on each of the sides of the bar.

KNOB. Synonymous with boss.

KNOTTING. A process of painting, for preventing the knots of the wood from appearing through the various coats of paint. Knotting is done first with size and red lead; then with white lead, red lead, and oil. When the knots are very bad, and the painting intended to be of the best finish, silver leaf is laid over the knots by means of gold size.

KOUMISS. A vinous liquid, which the Tartars make by fermenting mare's milk. Something similar is prepared in Orkney and Shetland.

KREOSOTE. (See *Creosote*.)

KYANIZE. To prepare timber by Kyan's patent solution. (See *Kyan*.)

KYAN'S PATENT PREPARATION. A process of preserving timber from the dry rot, recently invented by Mr. Kyan, consisting of a solution of corrosive sublimate, in which the timber is immersed, whereby the primary element of fermentation is neutralized, and the timber rendered indestructible. It also effectually seasons the timber, occupying a space of only two or three months, instead of from two to six years, which is usually consumed in laying it to dry by the common method; and it also protects it from the ravages of insects.

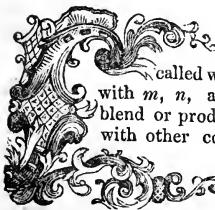

The first of the liquid letters, so called with the rest, that is, with *m*, *n*, and *r*, because they blend or produce a flowing sound with other consonants, and because they can be sounded for a length of time.

L is a letter of almost all languages, ancient and modern. As a numeral **L** reckons for 50. In abbreviations it stands for Lucius, L.L.D., Learned Doctor of Laws, &c. &c.

LABDANUM, OR LADANUM. The resin of the *cistus creticus*.

LABEL. A moulding projecting over a window, door, or other aperture, withinside the building. The word drip-stone applying outside the building. Label is also a Gothic architectural ornament, represented as follows:

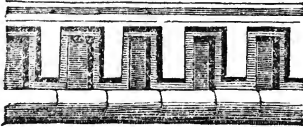

LABORATORY. An apartment or series of apartments, fitted up with the various utensils used in the study and pursuit of chemistry.

LABOURED. Any work which bears the appearance of constraint and hardness of style; opposed to free, graceful, or flowing.

LABYRINTH. A large and intricate edifice or garden, cut into various passages or meanders, running into each other, so as to render it difficult to get out. The following is the

ground plan of a celebrated one at Versailles:—

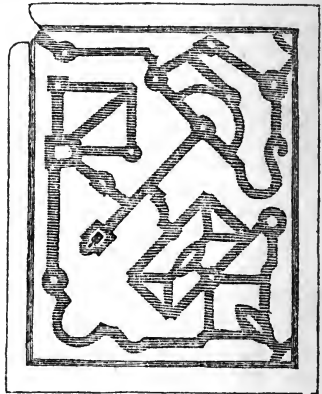

LABYRINTH. In metallurgy, the name of a series of wooden troughs, communicating with each other. The ore of a metal being pounded is mixed with water, and poured into the upper trough. Here the grosser particles subside, when the still thick liquid flows to the next trough, where more of the ore is left behind; until at length all the troughs are filled, each with particles finer than those in the preceding trough.

LAC. A kind of resin, used in making sealing-wax, lacquers, &c. There are three kinds, called *shell lac*, *seed lac*, and *stick lac*.

LACCIC ACID. A peculiar acid, separated by Dr. John from stick lac. It is yellow,

crystallizable, and unites with the alkalis, lime, mercury, and lead.

LACCINE. A peculiar substance, said to form the base or distinguishing property in stick lac.

LAC DYE. LAC LAKE. Two preparations of stick lac, imported in small cubic cakes from the East Indies, and extensively used in the production of scarlet dye.

LACE. An ornamental transparent fabric of linen or cotton thread, formerly made by hand, when it was called *pillow lace*; but of late years produced by machinery, and generally termed *bobbin net*.

LACMUS. (See *Litmus*.)

LACQUER. A yellow varnish, consisting of a solution of shell lac in spirits of wine, and colored by gamboge, saffron, annatto, or other similar color. Lacquers are chiefly used for varnishing brass and some other metals, in order to give them a golden color and preserve their lustre.

LACTATES. Compounds of the lactic acid.

LACTIC ACID. The acid of sour milk.

LACTOMETER, or GALACTOMETER. An instrument for ascertaining the quality of milk, by the quantity of cream it casts up. One kind of lactometer consists of a graduated glass tube; this is filled to a certain height with milk, and set aside for some hours. Being then examined, the quantity of cream which rises is easily seen by the marks upon the tube. When the milk of several cows is to be compared, a number of similar tubes is employed, in which case they are set in a stand, like that of a test tube stand, as follows. The tubes are about half an inch in diameter.

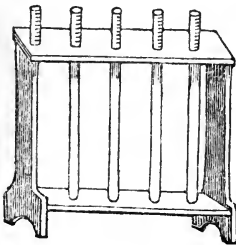

LACTUCIC ACID. A peculiar acid, discovered in the juice of a particular kind of lettuce, called the *lactuca virosa*.

LACUNAR. A ceiling or soffit, ornamented with pannels.

LAGAROUSE'S LEVER, is a contrivance by which a reciprocating circular motion may be converted into a continued rectilinear one. The centre channel represents a fixed shaft, in which a centre is placed, upon which the lever A B works. To A B are attached two hooks, and as the lever moves up and down on its centre, the hooks take

hold alternately of one of the teeth of the rack, either on the one side or the other, moving at the same time the rack steadily upwards.

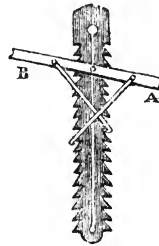

LAKE. A general term for many yellow and red vegetable colors, when made of aluminous earth, and the coloring matter of a particular plant or the insect; thus we have *carmine, scarlet, madder, yellow, cochineal, lac lakes, &c.*

LAMINA. A thin coat or plate of metal, or other hard substance.

LAMINABLE. Said of a metal which may be flattened out into a thin sheet, by being passed between steel rollers.

LAMP, Safety. (See *Davy*.)

LAMP BLACK. Finely divided charcoal, or soot, obtained by the imperfect combustion of various oily or resinous substances. It may be obtained in small quantities by holding any cold substance close over a common lamp. The manufacture on a large scale is conducted in chambers lined with old sacking, upon which the soot from a large smoky fire is collected. It is used as the basis of black paint, and for other purposes.

LAMPIC ACID. A term given by M. Daniell to the acid produced by the slow combustion of the vapor of alcohol and ether, in a lamp without flame. It is supposed to be acetic acid, modified by a peculiar hydro-carbon.

LANCET WINDOW. A long and narrow window, pointed like the blade of a lancet.

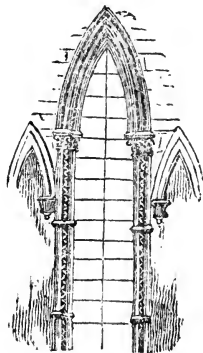

LAND COMPASS. (See *Compass*.)

LANDING. In building, the first part of a floor at the head of a stair.

LAND-LOCKED. A term applied to a harbour or piece of water, which is so environed by land on all sides as to exclude the prospect of the sea, unless over some intervening land.

LAND-MARK. Any thing by which the boundary of a property is defined. In naval language, it is applied to any conspicuous object, which serves as a guide on entering a harbour, or avoiding a danger.

LANDSCAPE. The view or prospect of a country, extended as far as the eye can reach.

LANDSCAPE GARDENING. The art of laying out gardens, so as to produce the effect of natural landscape.

LAND-SLIP. A portion of land on a coast, the verge of a hollow, the side of a mountain, &c., which has slipped out of its place, in consequence of an earthquake, the effects of rains, frosts, &c. In the south coast of Isle of Wight, land-slips are very common, and some of them consist of many acres; which, owing to the rains, joined with the undermining action of the sea, have slid down, almost without disturbing the crops, so as to look like a field upon the beach.

LAND-SPRINGS are sources of water, which only come into operation after heavy rains. The cause of them is, that at a short distance beneath the surface of the ground, a retentive stratum of ground, (clay, or marl, for example,) prevents the rain from penetrating more deeply into the earth, consequently it is kept near the surface, gushing out as soon as it finds a channel, and being in but a comparatively small quantity is soon exhausted.

LANE'S DISCHARGING ELECTROMETER, or the **MEDICAL ELECTROMETER,** being used chiefly for medical purposes. This useful instrument is represented and described as follows:—

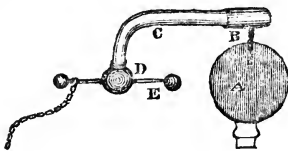

A is supposed to be a cross section of the prime conductor of an electrical machine. B is a brass cap, forming the end of the electrometer; it is made with a wire beneath to fit the hole of the conductor. C is a bent glass tube. D a brass ball at the end of it. E is a wire with a ball at each end of it, which wire is moveable backwards and forwards. When a shock is to be taken, the ball E is placed at a certain distance from the

surface of A. A is connected with the inside of the Leyden jar or battery which communicates the shock, and the chain is connected with the outside of the jar. When the jar is charged to such a degree of intensity as to acquire force enough to strike across from A to E, the discharge will spontaneously take place.

LANTANIUM. A metallic substance, discovered in a mineral called *cerite*, being blended with the oxide of cerium. The oxide of lanthanum is of a brick red color.

LANTERN. A small turret or cupola, with apertures, raised upon the summit of a building for the purpose of giving light to the interior. The small round or octagonal termination to a dome or tower is also so called, as in St. Paul's Cathedral. The roof of Westminster Hall has a lantern on the ridge of it.

LANTERN. In mechanics. (See *Trundle*.)

LANTERN, MAGIC. (See *Magic Lantern*.)

LANTHORN. (See *Lantern*.)

LAPIDARY. A person who cuts and polishes precious stones, forming them into brooches, ear-rings, and other ornamental articles.

LAPIDARY STYLE OF ARCHITECTURE, denotes the style proper for monumental and other inscriptions.

LAPIDARY'S WHEEL. A machine used by lapidaries to grind and polish precious stones and gems. The wheel is of various forms, the most simple is represented below:—

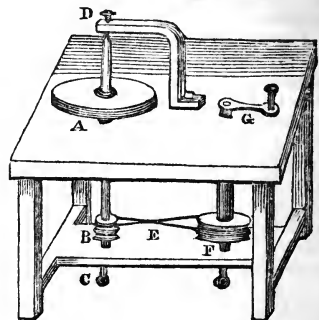

A is a wheel, made of wood, iron, lead, or other material, according to the hardness of the stone to be ground. This may be taken off its spindle, and another wheel, or *lap* as it is called, substituted. The upright spindle C D, which bears the lap A, also bears beneath the table the pulley B. By a cord which is attached to this, a connection is made with the larger pulley F, the spindle of which is terminated above by the handle G; so that upon being turned, motion is communicated by the pulleys and cord to the lap A, and the workman holding a stone or other body to A, at the same time that he

turns the handle with the other hand, will, of course, occasion a friction between the lap and stone. It only remains, therefore, to furnish A with some sharp-cutting substance, such as emery, diamond dust, &c., and the stone will be ground away, while a fine powder, such as putty powder, and with another lap, will polish it.

LAPIDIFICATION. The art of cutting and polishing stones, as practised by the lapidary.

LAPIS CAUSTICUS. An old name for caustic potass.

LAPIS ELECTRICUS. A name given by Linnæus to the tourmalin, that stone exhibiting an electrical attraction when heated.

LAPIS INFERNALIS. An old name for lunar caustic, or fused nitrate of silver.

LAPIS LAZULI. An argillaceous stone of a beautiful blue color, which when pounded and ground forms for the water color painter the finest blue pigment hitherto discovered, commonly called and known as ultramarine. This stone is discovered in various countries; those of Asia and Africa, however, greatly surpass, both in beauty and real value, the Bohemian and German sorts.

LARCH. A kind of fir timber, useful for railing, posts, and other similar purposes, especially as worms will not destroy it, and the weather exerts but little influence upon it. Numerous machines are framed of larch, and the masts of ships often made of it.

LATERAL EQUATION. A term used by some old authors for what is now more commonly called a *simple equation*.

LATERAL EXPLOSION. The name given to certain effects of the electrical fluid when discharged in considerable quantity through a small substance. For example, if a large jar or battery be discharged by a metallic wire held in the hand, without the protection of glass or other non-conductor, it often happens that a slight shock is felt. This is called the *lateral explosion*.

LATH. A slip of wood used to support plastering, tiling, and slating.

LATH FLOATED AND SET FAIR. In building, three-coated plasterer's work, in which the first is called *pricking up*, the second *floating*, and the third *finishing*.

LATH LAID AND SET. In building, two-coated plasterer's work. The first coat is called *laying*, the second *finishing*.

LATHE. A machine used by various artizans, particularly by the turner, for the purpose of cutting the substance fastened to it of a circular, or more rarely of an oval form. Lathes are of two general descriptions; in one of which the tool revolves, such as the brush-maker's lathe, and the seal engraver's lathe, (see *Seal Engraver*.) In the other kind, the material revolves, and the tool is held towards it, such as the common lathe, (about to be described,) the potter's wheel,

&c. (See *Potter's Wheel*.) Common lathes take also various names, according to the manner of putting them in motion, as the *pole lathe*. (See *Pole*;) the *foot lathe*, &c. The following is called the *triangular bar foot lathe*; the motion of it being occasioned by the foot and the bed being formed of a triangular bar of iron. It may be thus represented:—

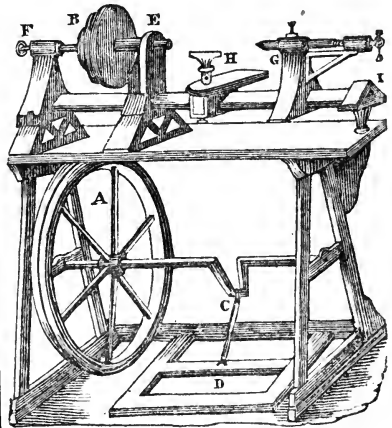

A is the fly wheel, which has mostly three or four grooves around its circumference. This is put in motion by its being connected by means of the cranked spindle which passes through its centre, and by the hook C with the treadle D, which is worked by the foot; the back part of the treadle being on hinges to allow it to rise and fall. A cord passes under A on to the top of the mandrel B; (this is accidentally omitted in the figure,) giving that a circular motion within a shoulder at E, and a screw point at F. Whatever is to be turned is fixed upon the projecting part of the mandrel at E. G is called the *poppit* head or *back poppit*, or puppet, which slides backwards and forwards, and holds by the point near G, the end of the work to be turned. H is called a *rest*; it also slides along the triangular bar or *bed*, and may be adjusted to any height or distance required, by means of a screw beneath, and one at the side, shown by a black dot. When the treadle is put in motion, it turns the crank, that the fly wheel, then by the cord the mandrel, and with it whatever may be attached to it. The tool resting steadily upon H, cuts away all the material which comes against its edge; and as the material turns round a centre, the tool will, of course, cut away all parts which are farther from the centre than its point, consequently it cuts the material into a circular form.

LATHE, *Appendages to*. Such implements as are used with, and are indispensable to a lathe, though forming really no part of it; such are *chucks, boring collar, rests &c.* (See these terms.)

LATITUDE. In geography and navigation, is the distance of a place from the equator, reckoned on an arc of the meridian, inter-sected between its zenith and the equator. *North* latitude is north of the equator. *South* latitude south of the equator. In astronomy, as of a star or planet, its latitude is its distance from the ecliptic reckoned towards the poles of the ecliptic, either north or south.

LATITUDE, *Difference of*, is the nearest distance between the parallels of latitude of two places. To find this difference, when the latitudes are both north or both south, subtract them from each other; when one is north and the other south, add them together.

LATITUDE, *Geocentric, of a Planet*, is its latitude as seen from the earth. This, though the planet be in the same point of its orbit, is not always the same, but alters according to the position of the earth in respect to the planet.

LATITUDE, *Heliocentric, of a Planet*, its latitude or distance from the ecliptic, such as it would appear from the sun. This, when the planet comes to its orbit, is always the same.

LATITUDE, *Middle*. The middle point between two latitudes or places. A particular method of directing a ship's course, and calculating her way, is called *middle latitude sailing*.

LATITUDE *of the Moon*, is her ascending or descending towards or away from one of her nodes, and is according to circumstances, called *north ascending, north descending, south ascending, and south descending*.

LATITUDE, *Parallels of*. Circles of the sphere parallel with each other and with the equator, upon which the latitude of places is seen.

LATTEN. A fine kind of brass, used in the middle ages for crosses, candlesticks, &c. The exact proportion of ingredients is not known. Latten now signifies the thin plates of iron covered with tin, of which domestic articles, such as saucepans, &c., are made, and which usually go by the name of tin-ware.

LATTICE. Windows formed of leaden frames, as common, not merely in our days, for cottages, attics, &c., but used almost exclusively in the Gothic buildings of the middle ages. They are properly called lattice windows only when the panes of glass are diamond-shaped, and placed with one of the points upwards; otherwise they are merely called lead-lights.

LAVA. The substances which flow in a melted state from a volcano.

LAURINE. A crystallisable substance formed in laurel berries.

LAWN. A fine variety of cambric, formerly manufactured almost exclusively in Flanders; now chiefly made in Scotland, and the north of Ireland.

LAY FIGURE, or **MANNIKIN**. A figure of wood, the joints of which are made to play with as much ease as possible, for the purpose of affording the artist opportunities to judge of the different effects of various positions of the human body.

LAYER. (See *Course*.)

LAYING. The first coat of plaster put upon a partition, the surface whereof is roughened by a birch broom, that it may better hold the coat of fine plaster afterwards to be put upon it.

LEAD. A whitish blue metal, soft and flexible, not very tenacious, and consequently incapable of being drawn into wire, though it is easily extended into thin plates under the hammer. Its specific gravity is 11.35. It melts at 612°. In a strong heat it boils and emits fumes, during which time, if exposed to the air, its oxydation proceeds with considerable rapidity. Most of the acids attack lead, (not the sulphuric, unless it be concentrated and boiling.) It also unites with most of the metals, and with sulphur.

LEAD, *for Sounding*. A mass of lead of about 11 pounds weight, which is attached to a cord of about 20 fathoms (40 yards) in length, used for ascertaining the depth of the sea or a river. The line is marked at 5, 7, 10, 13, 17, and 20 fathoms; the numbers between are called deeps. Thus, by the *mark 7*, by the *deep 9*, indicates 7 and 9 fathoms respectively.

LEAD, *Black*. (See *Plumbago*.)

LEAD, *Sugar of*. The acetate of lead.

LEADS. A printer's term for the thin pieces of type metal used to space out the lines in a page of type, when such is necessary.

LEADERS. The principal wheels in any kind of machinery are so called.

LEAF BRIDGE. A bridge similar to a draw-bridge; the only difference being that in a draw-bridge one platform is let down, and in a leaf bridge two platforms, one on each side of the chasm to be passed.

LEAN-FACE LETTER. A letter is so called when of slender proportions in comparison to the width of it.

LEAN TO. A small building which has a shed roof, and is attached to a larger building.

LEAP YEAR. A year containing 366 days. It occurs every four years, omitting the years that indicate three out of every four centuries. To ascertain leap year, divide the number of the year by four, if nothing remain it is leap year, otherwise not: thus, 1600 was leap

year, but 1700 and 1800 were not, nor will 1900; but 2000 will be leap year.

LEAT. An artificial channel for conducting water for the working of water wheels and other purposes.

LEATHER. The skins of animals prepared with lime water, and afterwards with astringent substances, which penetrating the substance of the skin, render it tougher, less porous, and more lasting.

LEAVEN. A piece of sour dough used to ferment and render light a much greater quantity of dough or paste.

LEAVES. In architecture, ornaments of carved work, forming part of the more ornamental capitals; also introduced into festoons, scrolls, wreaths, &c. In the arts, leaf indicates any thing flat and thin, as leaves of metal, the leaves of a pinion, &c.



LEDGERS. In building, horizontal poles, used in scaffolding, lying parallel to the wall opposite to which the scaffold is erected.

LEGS OF A RIGHT-ANGLED TRIANGLE, are the base and perpendicular, or the two shorter sides.

LEGUMINE. A modification of gluten found in peas and beans.

LEMNA. In mathematics, a previous proposition laid down in order to clear the way for some following demonstration, and prefixed either to theorems in order to render their demonstration less perplexed and intricate, or to problems to make their resolution more easy and short.

LEMNISCATE. The name of a particular mathematical curve, formed much like the figure 8. It has the peculiar property, that a straight line drawn through it lengthwise will divide it into four parts, as D E J K; or if drawn across it transversely, into two parts, as by the line F G. The line B A C, and the line H I, are considered to cut the curve in the same manner as the other lines,

the point A being reckoned double as the curve there crosses itself.

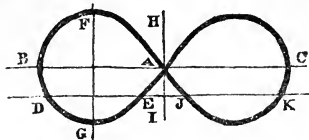

LEMONS, Acid of. The citric acid.

LEMONS, Salt of. The binoxalate of potash.

LENGTH. The greatest extension of a body.

LENS. A piece of glass or other transparent substance having its two surfaces so formed that the rays of light in passing through it have their direction changed, and made to converge or diverge from their original parallelism, or to become parallel after converging or diverging. Lenses receive particular denominations, according to their form, as *convex*, that which is thickest in the middle; if one side only be rounding, it is called *plano-convex*, as B; if both sides, it is called *convexo convex*, or now more frequently *doubly convex*, C. If the lens be thinnest in the middle, it is concave, either *plano-concave*, D, or *doubly concave*, E. If one side be concave, and the other convex, it is a *meniscus* lens, F; and if a plano-convex lens be cut on its convex side into a number of faces or *facets*, it is called from the effect which it produces, a *multiplying* glass or lens. Some authors include among lenses, the flat glass, calling it a *plano* lens, as A, and also the triangular prism, H, but these are not truly lenses. A globe of glass may be considered as a doubly convex lens.

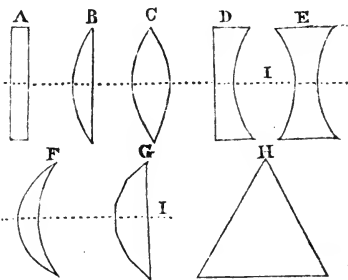

The *axis* of a lens is the line which passes perpendicularly through the centre of it, as I, I, I. Lenses are either *blown* or *ground*. Blown lenses are small globules of glass, melted in the flame of a lamp by a blow-pipe. Ground lenses are such as are ground of the required form, by means of a lathe, or other machinery. Polyzoal lenses are large, and made up of several pieces.

LEVITY. Lightness, or the quality of certain bodies which gives them a power of ascent, either upwards in the atmosphere, to the surface of water from a depth beneath, &c! &c., being thus opposed to gravity, by which bodies have always a tendency to descend. Levity is therefore nothing distinct in itself, but only an absence of weight.

LESLIE'S ÆTHRIOSCOPE. (See *Æthrioscope*.)

LESLIE'S DIFFERENTIAL THERMOMETER. (See *Air and Differential*.)

LESLIE'S PHOTOMETER. (See *Photometer*.)

LESLIE'S THERMOMETRIC HYGROMETER. A thermometric hygrometer is an instrument formed from a differential thermometer, by covering one of its balls with tissue paper or black silk. Being kept moist with water, the evaporation produces cold, and that in a degree exactly accordant with the state of dryness in the atmosphere. A B is the differential thermometer; the ball B being naked, that at A covered. C is a vessel of water, which has a few filaments of cotton that reach from the liquor in it to the covered ball. This acts as a syphon, and keeps the ball moist. The graduated scale shows the degree of evaporation. When this hygrometer stands at 15°, the air feels damp, from 30 to 40° we reckon it dry, from 50 to 60° very dry, and from 70° upwards we should call it intensely dry.

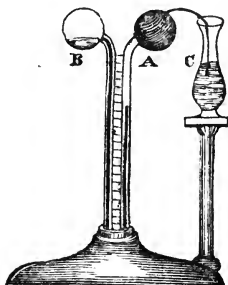

LEUPOLD'S STEAM ENGINE, sometimes called the high pressure lever engine, is described as follows:—The boiler C communicates by a cock of a peculiar construction, (see *Four-way Cock*), D, with the bottom of two cylinders, having pistons A, B, moving in them. These pistons are attached by their rods to two levers, the other ends of which work the pump rods F G. I is the eduction pipe, to convey away the water raised. H is the fire place.

In the situation of the engine shown, the steam from the boiler flows through the passage into one of the cylinders, and presses the piston upwards. This depresses the pump

rod K, fixed to the other end of the lever, which forces the water up the pipe I. When

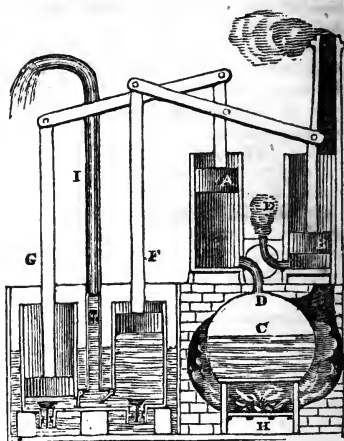

the steam has raised the piston A to nearly the top of the cylinder, the cock is turned, and the passage between this cylinder and the boiler is closed, and a communication is opened from the inside of the cylinder into the atmosphere. At the same time a passage is opened for the steam beneath the piston B of the other cylinder, which then, in like manner as the former, discharges its proper quantity of water. Thus the action is continued alternately, owing to the cock altering the channels of communication from one cylinder to the other.

LEVEL. A mathematical instrument, used for drawing a line parallel to the horizon, and continuing it out at pleasure, by this means finding the true level, or the difference of ascent and descent between any two places; for conveying water, levelling the surface of floors, and for various other purposes, connected with surveying, hydraulics, architecture, &c. There are numerous forms given to the instrument; one of the commonest of which is the *spirit* or *air* level. This consists of a tube of glass, filled with spirits of wine, except space enough for a single bubble of air. When this tube is placed upon a perfectly level surface, the air bubble will rest exactly in the middle of the upper surface of the tube. A figure of this instrument is seen in the middle of the following cut. The *water* level is on a different construction. The most simple form is that of a long trough, open at the top, in which water being poured, it is seen if the water continues of a true level, by a line made along the side of the box, or else by its running over at one end; but a better construction is that of a tube, open and bent

at both ends. This is nearly filled with water or mercury, and two floating sights are placed one at each end; looking through these, if the wire which is placed across one of the sights, upon looking at it from a little distance, exactly coincides with the wire across the other sight, and also with any distant object whose level is to be ascertained, it is known directly that the three are on the same level.

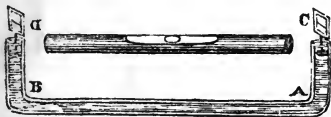

The level used by the carpenter and mason is well known, consisting of a straight bar of wood as a foot, with an upright bar in the centre of it, a plum-bob and line being suspended in the centre of the upright piece, as A and B. The *artillery foot level* has a line and plummet, or bob, with two legs, and a scale of 90° between them. When the bob hangs in the middle of the scale, the feet rest on a level surface, otherwise one foot must be raised accordingly. So on uneven ground, the degree cut by the bob line shows the degree of acclivity or descent as C. Level is also a name given sometimes to a canal, or to a low, flat tract of country. Likewise in mining, a seam or stratum of coals, or other mineral, running horizontally is a *level*.

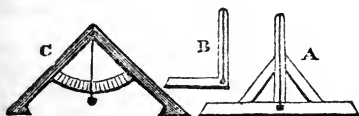

LEVEL CROSSING, is such a part of a railroad as crosses a road upon the same plane or level as the road itself.

LEVELLING. The art of finding a true horizontal line, or of rendering a surface parallel to the horizon.

LEVELLING STAFF. A graduated rod or staff, which is fixed up at a certain spot, as a criterion whereby to estimate the level of a neighbouring spot of ground.

LEVER. In mechanics, an inflexible straight bar, supported in a single point on a fulcrum or prop, and used for the raising of weights. In levers, three things are to be considered; the *weight* to be raised, the *fulcrum* or support, and the *power* employed. According to the relative position of these, levers are said to be of three kinds. A lever of the *first* kind has the fulcrum between the weight and the power, as a poker when in use, and also in the following figure, No. 1. Double

levers of this kind are seen in scissors, pin-cers, snuffers, &c. When the weight is between the fulcrum and the power, it is called a lever of the *second* kind, as the oars and rudder of a boat, the water being the fulcrum or resistance, the rower the power, and the boat to be moved the weight. (See fig. 2.) A lever of the *third* kind has the power between the fulcrum and the weight, such an one is a ladder lifted by the middle to raise it against a wall, pushing open a gate, the fire tongs, &c. Levers may be either bent or straight.



LEVIGATION. The mechanical process of grinding the parts of bodies to a fine paste.

LEWIS. An instrument used by masons for lifting stones of great weight, when they are to be fixed in a building. The cut shows a longitudinal section of one. A hole is first cut in the stone, which hole is larger beneath than at the surface. In this are inserted two tapering pieces of iron, A and B. A third iron C is driven between them; a staple to lift by is put over these three irons, and the whole fastened together by the bolt D E. It is evident that as the irons fit the hole, the stone if sound will readily be lifted up.

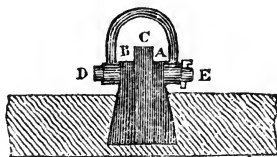

LEY. (See *Lye*.)

LEYDEN PHIAL, LEYDEN JAR, or ELECTRICAL JAR, is a glass phial or jar, coated both within and without to a certain height with tinfoil or some other conducting substance, and having a chain, wire, and ball, connected with the inner surface, which may be charged with, and employed as a recipient for the electric fluid. This fluid being drawn off again suddenly, occasions an electrical shock. Glass which is flat, or of any other shape, so coated and used, has also received the same denomination. There are various modifications of this instrument. (See *Magic Picture, Harris's Diamond Jar, &c.*)



LEYDEN JAR with MOVEABLE COATINGS.

The name of a particular modification of the common Leyden jar; the difference being that in the present instance the coatings are formed of tin, so that the glass when charged may be taken out of its coatings, and placed in others; when the shock or discharge being made, it will be proved that the electric fluid, disturbed by charging the phial, adheres to the glass, and not to the metallic coats. In the cut, A represents the jar, complete; B shows the outer cover; C the inner cover and ball attached.

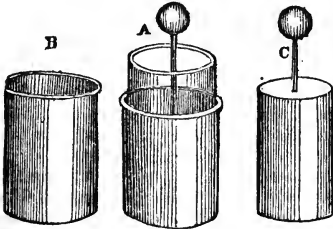

LIBAVIUS, Fuming Liquor of. Deutochloride of tin.

LIBRATION. A certain motion of either the earth or moon. The *libration of the moon* is more particularly an apparent libratory motion of that body about her own axis, whereby we see a little more than one-half of the lunar disc; or rather it is in consequence of our seeing more than one-half of it, that the moon appears to have such a motion. The *libration of the earth* is a term applied to that motion by which the earth's axis is kept at one time parallel to what it is at another, whereby the poles always point to the same spot in the heavens.

LICHENIC ACID. An acid which has been discovered in certain species of lichens.

LICHENIN. A starch-like substance extracted from the Iceland moss.

LIFE-BOAT. A large boat, made particularly buoyant by hollow, empty tubes of metal, or small casks being attached to it, which prevents its sinking, even when loaded with a crew, and full of water; some life-boats receive their buoyancy from being cased with cork. The intention of life-boats is to save the crew of stranded vessels.

LIFE-BUOYS. A light substance or contrivance intended to support a person in the water and prevent him from sinking. The corks used by swimmers are of this description:—Bags or belts of air are perhaps among the most simple and effectual life-buoys. They are, when used, if small, to be fastened round the neck of the person by means of the strings attached to them, and while the bag is void of air, or in a collapsed state; then air is to be blown into the stop-

cock seen as an orifice in fig. A, and sideways in fig. B, until it is properly inflated, when the stop-cock being turned off, the apparatus becomes so buoyant as to sustain the head of the person wearing it comfortably above the water. If made larger, it is to be placed under the arms. It may, as before, be either tied on, or if made without strings, as A, the wearer steps into it.

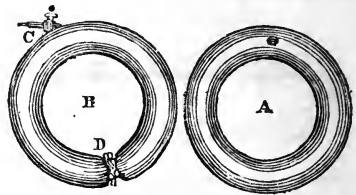

Another life-buoy, the invention of Lieut. Cook, R.N., for the assistance of persons who may fall overboard at night, is seen in the following cut:—It consists of two copper balls A, B, connected together by a wooden rod, and between the balls is a fusee, which burns with a brilliant light and so strong a fire that the washing of the sea cannot extinguish it. This can be lighted and let down from a ship in ten seconds, and falling near the drowning man, not only is a mark for him to reach, but of sufficient buoyancy to sustain him above water until a boat can arrive, to the course of which it is also a sure beacon. The machine is so weighted below as to stand erect in the water.

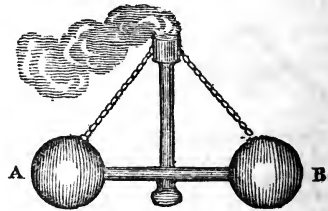

LIFT PUMP. The form and construction of the common or lift pump is shown in section in the following figure, in which F is the cylinder or barrel. D is an air-tight piston, which moves or works within it, worked by the handle or lever J. G is the suction or feeding pipe descending into the jar of water A, which represents the well. C is a valve at the bottom of the barrel, and covering the top of the feeding pipe; and E a valve in the piston, both which valves open upwards. B B is a stand for supporting the pump above the jar of water. Raising the piston, from the bottom to the top of the barrel, will produce a vacuum in the lower part of the barrel, and the pressure

of the air upon the surface of the water in the well will force sufficient water through C to fill this vacuum. Depressing the piston, the valve E would be opened, and the water flow through the opening, while the next upward stroke would lift it into H, whence it would flow through the nozzle I.

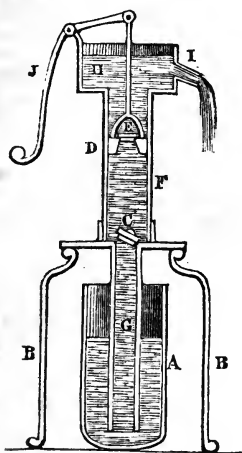

LIFT TENTER. (See Governor.)

LIFT WALL. The cross wall of a lock chamber.

LIGGER. LEDGER. The horizontal timbers of a scaffolding are so called by workmen, when they are parallel to the building.

LIGHT. The principle or substance which renders objects perceptible to our sense of seeing. Some consider light as a fluid of a peculiar character; others consider it merely as a principle, and attribute it to a sort of vibration propagated from the luminous body through a subtle ethereal medium. The chief properties of light are, that it always travels in perfectly straight lines, yet is capable of being diverted out of its course, when striking against a polished surface, suffering *reflection*; also when passing from one medium to another of different density, which is called the *refraction* of light. Each ray of white or solar light may be decomposed into rays having various colors, giving rise to the sciences of *chromatics* and *polarization*. It travels with astonishing rapidity, at the rate of 12 millions of miles in a minute, or from the sun to us in 8 minutes; and under certain circumstances, the rays of light impede, in others strengthen each other's action; this is called the *interference* of light. (See *Aberration, Interference, Reflection, Refraction, Polarization, &c.*) Light, in a painting, is the part most illuminated, and consequently represented as the

brightest. It is called a *natural* light, if the result of the shining of the sun or moon; or *artificial* light, if occasioned by a fire, candle, &c.

LIGHT. The upright space between two mullions of a window, or between a mullion and a jamb.

LIGHTS, *Northern*. (See *Aurora Borealis*.)

LIGHT-HOUSE. An erection, generally in the form of a tower, built upon a coast, harbour, or adjacent to dangerous rocks, for the purpose of warning ships of their situation, lights of various descriptions being introduced at night.

LIGHTNESS. In all the arts, a term opposed to density, heaviness, or clumsiness; for example, in architecture, a building of airy and elegant proportions. In painting, a picture, whose effect is graceful, sunny, or lively. In sculpture, a statue, capital, &c. delicately cut, and with flowing drapery, clear leaves, &c.

LIGHTNING. The electric fluid in a state of considerable disturbance and condensation, which passes visibly from cloud to cloud, from a cloud to the earth, or more rarely from the earth to a cloud. Lightning is of three kinds, *sheet* or *summer* lightning, which is unattended with thunder, and which appears in a diffused sheet of light near the horizon in warm weather. *Forked* lightning is that zigzag and rapid emanation which attends and indeed constitutes a thunder storm, thunder always accompanying it, and indeed being the consequence of it; and *ball* lightning, a still more dreadful kind, where the electric fluid descends in a dense straight stream, and appears to roll along the ground as a ball of fire; this kind is very rare and dangerous. (See *Thunder Storm*.)

LIGHTNING CONDUCTOR. An apparatus to preserve ships and buildings from the effects of lightning. It consists of a pointed rod of copper, half or three-quarters of an inch in diameter, pointed at top, and projecting two, three, or more feet above the chimney, or other highest part of the building, the lower end being inserted four or five feet in the ground. Its action is as follows:—Should lightning approach the building, it would, most likely, be drawn away silently by the pointed wire; or, if it should strike the building, the conductor would convey it to the earth without its doing any injury.

LIGHTNING, *Theatrical*. This used to be produced by the fine powder of *lycopodium*, projected with a strong powder-puff, and set light to. Rosin, finely powdered, is now used in the same manner, and for the same purpose.

LIGNIN. The woody fibre of vegetables. Timber with the sap, oils, resins, &c. which it may naturally contain being boiled o t is *lignin*.

LIGNITE. Wood converted into a kind of coal.

LIGNUM VITÆ. A very hard kind of wood, the produce of the *guaiacum* tree. The neat wood is a blackish brown; the young wood, nearly white. When used in machinery, which it is for pulleys, gudgeons, &c. it has the peculiar property of not requiring oiling to diminish friction, itself yielding copiously a resinous substance. It is extremely hard, and the grain of the wood so interlaced one with another, that it is almost impossible to split it, particularly of old trees.

LIKE ARCS. The parts of lesser circles, containing an equal number of degrees with the corresponding arcs of greater circles.

LIKE QUANTITIES. In algebra, those which consist of the same letter and power.

LIMB. The outermost border, or graduated edge of a quadrant, or other mathematical instrument; also the edge of the sun or moon, as the *upper* limb signifies the highest edge; the *lower* limb the bottom edge, &c. Thus, we speak of the altitude of the sun or moon's lower or upper limb.

LIME. In chemical language, the oxyde of calcium, or a substance composed of a white metal, called calcium and oxygen; commonly known as a white alkaline earth, existing abundantly in nature, in a great variety of forms and combinations. The sulphate of lime is well known as plaster of Paris. The carbonate constitutes the great and valuable class of the marbles, lime-stones, oolites, chalk, &c. It may be obtained in considerable purity by submitting a piece of marble to a white heat for an hour in an open crucible. Pure lime is white, acrid, caustic, and converts the vegetable blues to greens. It is difficult of fusion, but promotes the fusion of other bodies. When intensely heated, as by the oxy-hydrogen blow-pipe, it is remarkable for its luminosity. It is an essential ingredient in mortars and cements. When fresh burned, and while perfectly dry, it is called *quick lime*, and is then in its most caustic state. When water is added to this, there is a great rise of temperature, and a bulky white powder is obtained, which is a *hydrate*, and is commonly called *slaked lime*. Lime obtained from certain hard lime-stones is of a yellow color until slaked.

LIME, Cream of. Water added to quick-lime, until it assumes a cream-like appearance and consistence.

LIME, Oil of. An old term to designate the chloride of calcium, (muriate of lime,) which has become deliquescent by exposure to the air.

LIME-KILN. A kiln for the purpose of burning lime.

LIMESTONE. A calcareous stone, which being sufficiently burned or calcined, falls into powder upon the application of water,

and being then mixed with water and sand in certain proportions, forms a strong cement, called mortar.

LIMNING. The art of painting in water colors, in which sense it is used to distinguish it from oil painting. A word now seldom used, unless to signify herald painting on carriages, &c., which is done with oil colors.

LINE. A quantity extended in length only. A line may be conceived to be formed by the motion of a point; as for example, a rocket ascending, is but a point of light, yet traversing through the air it appears like a *line* of fire: so again, the meteor commonly called a shooting star, appears to be a line of light rather than a point. The intersection of surfaces are lines. A line is not considered to have any breadth. Lines are either *straight* or *right*, A; *curved* or *bent*, B; and *cob* or *mixed*, being partly straight and partly curved, C.



Lines, according to their position, may be either vertical or perpendicular; horizontal or sloping at a certain angle. Line also denotes a French measure, containing the 12th part of an inch, or the 144th part of a foot.

LINE, Equinoctial. (See *Equator*.)

LINE, Horary, or Hour Lines. In dialling, the intersection of the hour plane with the dial plane.

LINE, Visual, or Visual Ray. A ray of light reflected from an object to the eye.

LINE OF CENTRES. A line drawn from the centre of one wheel to the centre of another, when their circumferences touch each other.

LINE OF DIRECTION. In mechanics, the line in which motion is communicated.

LINEAR. Relating to lines, as opposed to the effects of light and shade: thus, linear perspective, treats of the representations of the *forms* of objects in different positions and at different distances, without reference to color, or other accidental circumstances.

LINING. The covering of the interior surface of a hollow body. In canal making, the thickness or coat of puddle or clay, sometimes applied to the bottoms or sides of canals to prevent them from leaking.

LINK. A portion of a chain.

LINSEED. The grain or seed of the flax plant, also the oil extracted from it. The former is used merely as a medicinal emulsion, in coughs, colds, &c., commonly called *linseed tea*. The latter, that is, the oil, is the usual vehicle employed by the painter, wherein to mix and grind his pigments.

LINTEL. A piece of timber or stone placed over a doorway, window, &c.

LIQUEFACTION. Melting or dissolving, as of ice.

LIQUID. That which besides having the property of fluidity has also a peculiar quality of wetting other bodies immersed in it.

LIQUID, or SAXON BLUE. A solution of the sulphate of indigo.

LIST. Synonymous with fillet.

LISTING. In building, cutting away the sappy edge of a board.

LITERAL EQUATION. That which is expressed in general terms by letters, being thus distinguished from a numerical equation, in which all the coefficients are given numbers.

LITHARGE. Calcined lead, forming a vitrified oxyde. It is used by painters to boil with linseed oil, which occasions it to dry much more easily than in its uncombined state, the litharge, or as it is called by workmen *lithérage*, being dissolved in the oil.

LITHIA. LITHIUM. A rare alkaline substance, extracted from *petalite*, and other minerals. It is the oxyde of a white metal, which has been called *lithium*.

LITHIC ACID. Synonymous with uric acid; it forms the commonest variety of urinary calculus.

LITHOGLYPH. The art of engraving on precious stones.

LITHOGRAPHIC CHALK. A material made in the shape of drawing crayons, and intended to produce the same artistical effect upon stone as the ordinary chalks do upon paper. The receipt for an approved chalk of this description is as follows:—Common soap 1½ oz.; tallow 2 oz.; white wax 2½ oz.; shell lac 1 oz. Soap is the only ingredient which must not vary; it is intended by the alkali it contains to render the whole miscible with water. When melted the last time, it may be cast in paper cartridges, or on a marble slab, and cut up into slips when nearly cold. It must be kept in well-stoppered phials that damp may not reach it. The wax and tallow are heated in an iron saucepan till they catch fire; the soap is cut into small pieces, and added by degrees, stirring the whole time. When dissolved, the burning is continued, till reduced to the volume the mass was before the putting in of the soap: then extinguish the flame, add the shell lac, pour a little on a cold plate, and see if, when cold, it breaks in two; if so, it is perfect. It is to be melted again, and the lamp black added.

LITHOGRAPHIC DRAWING INK, is for executing writings on stone, or drawing plans, &c., which shall be representations of those executed with a pen. Its composition is as follows:—Equal portions of tallow, white wax, shell lac, and common soap

melted together; afterwards add lamp black as a color. The method of manipulation is the same as for lithographic chalk. When finished, it should resemble Indian ink, and is to be used in the same manner with a fine pointed steel pen.

LITHOGRAPHIC PRESS. A machine for printing from stone or for producing impressions from a drawing made upon stone. The press we have given is called the lever press, and is one of the first constructed: (a more modern one will be found under the name of its inventor, Straker.) The present one consists of a strong square table; upon this the prepared stone is placed, one side of it being close to the lower end of a frame covered with leather, which lets down upon the stone, the sheet of paper being put between them. The workman wets the general surface of the stone, then inks the drawing with an inking roller. (See *Inking*.) He then adjusts the damp paper upon it, shuts down the flap of leather, then puts his foot upon a treadle seen beneath the table; this pulls down an obliquely-placed lever connected with it. The oblique lever is fastened to another lever at top, which, of course, is also pulled down by the action of the treadle, and the scraper hanging over the stone is forced tightly upon the flap; the printer places this at one end of the stone, and gradually draws it forward towards him, by which the ink is transferred to the paper, and the print is completed. It may be taken away, and the operation repeated for each impression. The above press is most fit for small work.

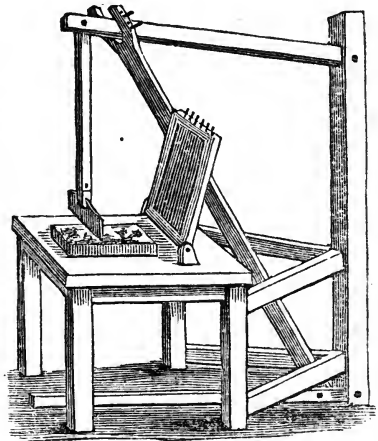

LITHOGRAPHIC STONE. A hard, smooth, compact kind of lime-stone, much resembling the *hone* stone in appearance, and adapted

for lithographic drawings. It is prepared for the draughtsman by first sawing into slabs, then grinding the surface with sand of different degrees of fineness until perfectly smooth and clean.

LITHOGRAPHY. The art of drawing upon and printing from stone. The first part consists in drawing on a stone previously made smooth and level with an ink or chalk composed of greasy materials, so mixed as to resemble soap. It is then washed with an acid, which changes the soapy ink truly into grease. The stone is now ready for the second process, the printing. It is washed over with gum water, which is suffered to dry; then taken to the press, sponged over with water, inked with a thick ink, which being oily, adheres readily to the grease on the stone, but not at all to the wetted surface; the paper is then placed upon it, and pressure applied, when the ink leaves the stone and adheres to the paper, forming the print desired, and which, of course, will be the reverse as to the position of the objects to that upon the stone.

LITHOLOGICAL. The stony structure or character of a body partly calcareous and partly organized. Thus, speaking of *shells*, we consider their *lithological* character; speaking of the molluscous animals which inhabit them, we treat of their *zoological* character.

LITMUS. LACMUS. TURNSOL. A blue liquid color obtained from the archill weed, (the lichen *roccella tinctoria*.) It is much used in dyeing, in staining furniture, and by the chemist as a test for acids, the most minute quantity of which turns it red.

LITRAMETER. An instrument invented by Professor Hare, of Pennsylvania, to ascertain the specific gravity of liquids; owing its efficacy to the principle, that when columns of different liquids are elevated by the same pressure, their heights must be inversely as their gravities.

Two glass tubes C C, of the size and bore usually employed in barometers, are made to communicate internally with each other, and with an elastic bag G, by means of a brass tube and two sockets of the same metal, into which they are severally inserted; the brass tubes terminate in a cock, in which the neck of the bag is tied. Between the cock and the glass tubes there is a tube at right angles to an opening into that which connects them. At the lower end of this tube, a small copper rod B enters through a collar of leather. The tubes are placed vertically in grooves, against an upright slip of wood, tenoned into a pedestal of the same material. Parallel to one of the grooves is a brass scale so graduated that each degree may be equal to $\frac{1}{220}$ of the whole height of the tubes. It is long enough to admit 140°.

Close to this scale a vernier E is made to slide so that the divisions of the scale are

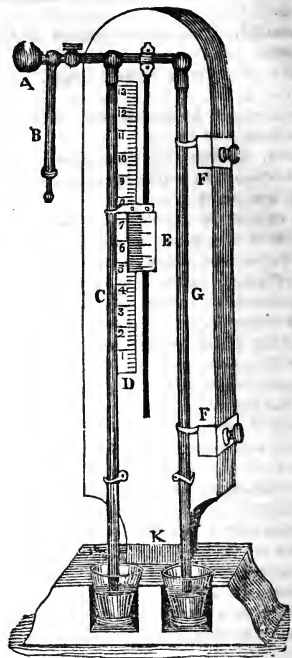

susceptible of sub-division into tenths, and the whole height of the tubes into about 2200 parts or degrees. There are also two sliding indices F F, to one of the tubes. To use the instrument, let a vessel of water be placed under one of the tubes, and a vessel of the liquid to be tried under the other, the tubes dipping in the vessels. The bag being compressed, the greater part of the air of the tubes is driven out, and the liquids occupy its place, and rise to a height according to their gravity, the heavier liquid, of course, occupying the lower place.

LIVER OF SULPHUR. Fused sulphuret of potassium; so called from its liver color.

LIXIVIATION. The washing of a substance in water in order to extract any soluble and saline particles contained in it.

LIXIVIVUM. A solution obtained by lixiviation.

LOADSTONE. A magnetic iron ore, which is black, with a slight metallic lustre. It occurs chiefly among the harder or primitive rocks, and is very abundant at Roslagen, in Sweden, where it is manufactured into a bar iron, particularly esteemed for making steel. Its name is derived from its inherent property of attracting iron and steel, or being in fact a

natural magnet. (See *Magnet*.) Although two or three instances are recorded of astonishing powers of attraction being shown by a loadstone, yet it is generally infinitely surpassed in strength by a bar of steel magnetized.

Lock. A well-known instrument for securing doors, and preventing their being opened, except by means of the key adapted to the lock.

Lock, or Weir. In engineering, all those works of wood or stone, or of both combined, which are erected to confine and raise the water of a river. The term lock, or pound-lock, however, more particularly denotes a contrivance, consisting of two gates, or two pair of gates, called the *lock gates*, and a chamber between them, in which the surface of the water may be made to coincide with that of the upper or the lower canal, according as the upper or lower gates are opened, by which means boats are raised or lowered from one level to another.

LOCK PADDLES. The small sluices used in filling and emptying locks.

LOCK SILLS. The angular pieces of timber at the bottom of the lock against which the gates shut.

LOCOMOTIVE ENGINE. A steam engine adapted to move itself forward, generally along a perfectly smooth surface, as the rails of a railroad. The term is used in contradistinction to a stationary engine.

LODE. In mineralogy, a vein containing metal.

LOGARITHMS, are a series of numbers in arithmetical progression, answering to another series of numbers in geometrical progression. These numbers are of the greatest possible use in almost all arithmetical and trigonometrical operations, because by help of them multiplication is performed by addition; division by subtraction; involution by multiplication; and evolution by division.

LOGARITHMIC CURVE, or LOGISTIC CURVE. A curve of such a nature that when it has its abscisses in arithmetical progression and its corresponding ordinates in geometrical progression, the abscisses may be considered as the logarithms of the respective ordinates, from which property the curve has its name. It is represented as follows:—A, B, C.

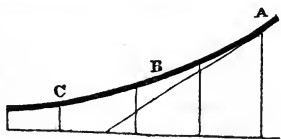

LOGARITHMIC, or LOGISTIC SPIRAL, is a curve having properties similar to the above, but differently constructed. Thus, divide

the quadrant of a circle into any number of equal parts in the points B, C, D, E, &c., and from the radii A B, A C, A D, &c. cut off A F, A G, A H, A I, &c. continually proportional, then the curve passing through the points F, G, H, I, J, K, will be the logarithmic spiral. In this instance the areas are as the logarithms of the ordinates, and hence the denomination of the curve.

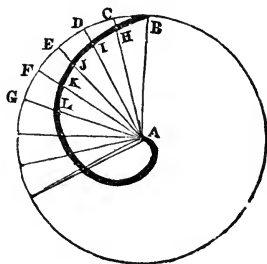

LOGISTIC LOGARITHMS, are certain logarithms of sexagesimal numbers or fractions, used in astronomical calculations. The logistic logarithm of any number of seconds, is the difference between the common logarithm of that number and the logarithm of 3600, the number of seconds in a degree. The use of these numbers is in computing a proportional part in minutes and seconds, or hours and minutes, or other sexagesimal divisions.

LOGOTYPE. Two or more letters cast in one piece, as ff, fl, æ, œ, &c.

LOGWOOD. The wood of a small tree, called the *hamatoxylon campechianum*. It is heavy, hard, compact, of a fine grain, capable of being polished, and scarcely susceptible of decay. Its chief use, however, is not as a wood; but on account of the fine red or purple dye which it yields both to water and alcohol, a solution with the former is valuable to the dyer, with or without alum or tartar.

LOMBARDIC ARCHITECTURE. A style of building the same as the Norman.

LONGIMETRY. The art of measuring lengths, accessible and inaccessible.

LONGITUDE. In astronomy, is the distance of the meridian of a star from the first point or degree of Aries, which is the position of the sun in the ecliptic at the time of the vernal equinox. In geography and navigation is the distance between the meridian of a place, and a certain fixed meridian from which the longitude is reckoned. Longitude is always *east* or *west*, and in this country is reckoned from Greenwich, so that the places on the meridian, (see *Meridian*.) which is exactly on the opposite side of the world from us have 180° of longitude, whichever way round we reckon; while those places

on the same meridian as Greenwich have no longitude.

LONGITUDE STARS. A term frequently used to denote those fixed stars which have been selected for the purpose of finding the longitude by lunar observations. The chief of these are as follows:—Aldebaran, Pollux, Regulus, Spica Virginis, Antares, Formanaut, and the largest star in Aquila.

LONG PRIMER. The name of a type. (See *Type*.)

LOOM. The machine used by weavers for the weaving of cloth, velvet, silk, &c.

LOOP, or LOOP HOLE. A narrow opening in a wall for the admission of light, and in time of siege serviceable for the archers to shoot their arrows through. They were in all the old castles and churches made very narrow outwardly, but widening gradually inwards.

LOTUS. A kind of water lily, of magnificent appearance, growing abundantly in the Nile, so much so as to have been considered by the ancient Egyptians as a votive plant, characteristic of the country. They, therefore, introduced a representation of it in most of their edifices, hieroglyphical tablets, &c. The lotus, as an architectural ornament, is as follows:—

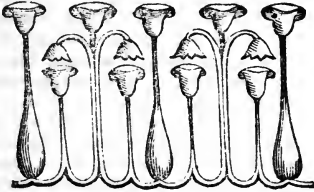

LOUVER WINDOW. Those openings or windows in church steeples, which are left open or crossed by bars of wood, placed so as to exclude the rain, but admit air, and allow the emission of sound from the bells.



LOUVER STONES or BOARDS, corruptly *Luffer Boards.* Those bars of wood, &c. which cross the lights of a louver window; also, the narrow boards lapping over each other, yet at some little distance apart, which are placed over the coolers in a brewery, or which compose the whole walls of a whitening, and sometimes a floor-cloth manufactory.

LOWER CASE. That case or assemblage of boxes, holding type for the printer, in which the small letters are kept. This case from being most used is always nearest to the printer's hand. The *upper* case or that farther from him contains the larger and smaller capitals, figures, &c.

LOW-PRESSURE ENGINE. A steam engine, the motion or force of which is produced by forming a vacuum within the cylinder, by drawing off the steam into another vessel, called the condenser, and there condensing it.

LOW WINES. A name given by the distiller to the product obtained by a single distillation of the wash or fermented saccharine and spirituous liquid first made for the purpose. Low wines are stronger than the original, but require to be re-distilled before they are fit for ordinary consumption. (See *Distillation*.)

LOXODROMIC CURVE, or SPIRAL. The path of a ship when her course is directed constantly towards the same point of the compass, thereby cutting all the meridians at the same angle. It is presumed that the ship is not sailing on a parallel, that is, not due east or west.

LOZENGE. A term used by mechanics and old authors for rhombus and rhomboid, or that shaped figure which we commonly call a diamond, from its being so figured on part of a pack of cards.

LOZENGE MOULDING. A particular shaped ornament used in the earlier Gothic styles of architecture. This moulding derives its name from being composed of straight, plain mouldings, crossing each other, and forming a series of lozenge-shaped depressions.



LUBRICATION. The oiling or anointing surfaces which rub together. This is most essential in machinery of all kinds to diminish friction. The common lubricating substances are fine olive oil for watch-work; soft soap and black-lead for wood; oil or tallow for machinery of a large kind.

LUCERNAL MICROSCOPE. A microscope adapted to exhibit objects of a magnified size upon a screen, they being illuminated by a lamp, and the rest of the apartment

supposed to be in darkness. The general external appearance of the instrument is that of the magic lantern, being furnished with a lantern of the same description to hold the light; and in the commonest kinds of instruments having the same lenses. In the better kind of lucernal microscopes, solar microscopes, and magic lanterns, the lenses are as follows:—

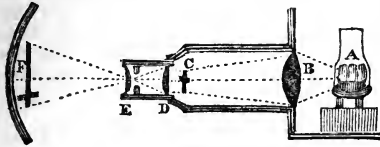

A represents the light, inclosed in a tin box. B a doubly convex lens, the side nearest the light being flatter than the other, in the proportion of 3 to 5. At C is a hole in the tube, where the object is introduced. At D and E are the magnifying lens; they are plano-convex, with their convex sides towards each other, and fixed in a small tube which slides in and out of the larger one—these lenses being fixed in reference to each other, according to their foci. The light from A strikes upon B, and passing through converges on to the object; passing thence to D, it is there still more converged, till the rays meet the third lens E. From this they diverge, and throw the appearance of the object on a white screen F, with the common lenses of the magic lantern. This screen must be made of the form of a part of a hollow globe, otherwise the figures will be much distorted, and clear only in the centre of the field of view; with the above lenses a flat screen may be used.

LUCIFER. A name given to the planet Venus when she appears in the morning before sun-rise.

LUCIFER MATCHES. Slips of wood dipped in such a composition that it will inflame either by friction, or when slightly touched with sulphuric acid. Those which are fired by friction are dipped in a mixture of gum water and phosphorus, melted together at a heat of not more than 120°. Those which inflame by the contact of the acid are tipped first with brimstone, and afterwards with the chlorate of potass, previously mixed in powder with twice its weight of powdered sugar; a little gum water being added to give consistence to the mixture.

LUMINARIES. Any objects giving light, but more particularly applied by way of eminence to the sun and moon.

LUMINOSITY. The power of emitting a light.

LUMINOUS WORDS. (See *Devices*.)

LUMINOUS DISCHARGER. (See *Discharging Rod*.)

LUNAR. Any thing relating to the moon; thus we say, lunar month, lunar cycle, &c.

LUNAR CAUSTIC. Fused nitrate of silver.

LUNAR CORNEA. Muriate of silver.

LUNAR DISTANCE. In navigation, a popular term used to indicate the problem of finding the distance of the moon from the sun or some fixed star, for the purpose of ascertaining the longitude.

LUNAR RAINBOW. A rainbow occasioned by the reflection of the light of the moon. It differs in no respect from the common rainbow, except in being exceedingly faint in colors. It is a very rare phenomenon.

LUNATION. The time between one full moon and the next.

LUNE, LUNETTE, or CRESCENT. The space between two unequal arcs of circles which cut each other. The apertures in a cylindrical or domed ceiling are by architects also called lunettes.

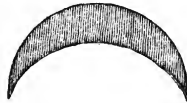

LUNGS GLASS. An instrument or apparatus used with the air pump, intended to prove the elasticity of the air. It consists of a glass globe, of about 4 inches diameter, with a foot to it, and also a brass cap at the top; within the glass is a small bladder, tied to a short tube, which is attached to the cap, and projects an inch or so within the glass. This tube passes out at the top, and is terminated by a small orifice. The lungs glass is placed under the receiver of the air pump, and as the air is exhausted the bladder collapses; being admitted it expands again, showing the exact action of the animal lungs in respiration.



LUPINITE. A bitter substance, extracted from the leaves of the lupin.

LUPULIN. The bitter and aromatic principle of the hop.

LUSTRE. A bright brass chandelier, suspended from a ceiling, as we see in churches, theatres, &c.

LUTE. A substance of a pasty consistence,

for joining or making tight the joints of vessels. Lutes are of various kinds. Common dough with salt in it is a useful lute for the distiller; putty is also often employed, or clay mixed with linseed oil. Lime slacked in the air, and mixed with the white of eggs, is another kind.

LYE. A solution of an alkali in water, particularly applied to dissolved potash.

LYE TROUGH. A square trough or box, in which lye is kept for the printer's use, that he may be enabled to wash the ink off the type which has been just printed from.

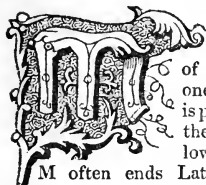

A liquid consonant and the twelfth letter of the alphabet. It has one unvaried sound, and is pronounced by striking the upper lip against the lower: it is never mute.

M often ends Latin words, but never Greek ones, the Greeks changing it into N. M is also a numeral letter, and among the ancients it was used for a thousand, or with a dash over it for a million. In contractions, it signifies Master, Marcus, Manlius, Meridies, mise or mix, or mixture, and maniple or handful.

MACARONI. An Italian production, made of a dough of fine wheat flour, and by passing through an instrument like a funnel, it assumes a round cylindrical form of the thickness of a goose-quill. It is used in domestic cookery for soups, ragouts, &c.

MACERATION. The steeping of a body in a cold liquid.

MACHICOLATIONS. Perpendicular holes left in the under side of overhanging parapets, gateways, and turrets, that the defenders within might shower down hot water, lead, &c. upon their besiegers.

MACHINE. In a general sense is any thing that is used to augment or to regulate moving forces or powers. The term, however, is generally restricted to a certain class of agents which seem to hold a middle place between the simple tools and the more complicated, termed engines; this distinction, however, has not a place in a scientific point of view; all such compound agents being really machines, the parts of which they are compounded being mechanical powers.

MACHINERY. Any collection of machines.

MACHINIST. The constructor or director of machinery; synonymous with engineer.

MACLE. The name of certain diagonal blotches or spots in minerals, like the diamond in cards; supposed to proceed from some disturbance of the particles in the act of crystallisation.

MACULÆ. Dark spots which occasionally appear on the surface of the sun, moon, and even some of the planets.

MADDER. A substance very extensively used in dyeing red colors, particularly on woollen cloths. The best is brought from the Levant, but a very large quantity is now brought from the East Indies. It is the stalk and leaves, and still better the root of a plant, called the *rubia tinctoria*.

MAGELLANIC CLOUDS. A name given to three permanent whitish appearances resembling the milky way near the south pole, being distant from it 13°.

MAGIC LANTERN. A well-known optical instrument, by means of which small painted figures on the wall of a dark room are magnified at pleasure. The following shows the common instrument:—A small lamp, with a reflector behind it, is placed in a tin lantern, to the front of which is a projecting tube open on both sides; at the side of which tube, and near that end which is nearest the light, is a hole, to move the sliders in and out. A second tube slides within the first. The requisite lenses are a thick plano-convex lens at that end of the tube which is fastened to the lantern; and a double convex lens at the outer end of the smaller tube. The slider of objects is placed in the square hole prepared for it; the light passes the plano-convex lens, strikes the picture, and passes to the smaller lens, whence it is cast on the white wall of an apartment, or a sheet, or other screen. An infinitely better way of *glassing* the lantern is described under the article *Lucernal Microscope*, (which see.)

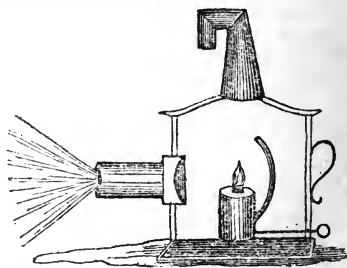

MAGIC LANDSCAPES. A name given to pictures which have been washed over with

sympathetic inks, so that in the natural temperature of the air the picture appears without color, but when warmed it seems like a tinted landscape. Chloride of cobalt forms the blue of the sky; chloride of copper gives a yellow, and acetate of copper a green color.

MAGIC PICTURE. An electrical apparatus, which under the appearance of a picture is so formed as to constitute a Leyden jar, and consequently when charged by the electrical machine will communicate a shock to those who incautiously touch it. A plate of glass, which fits a frame, is partly covered on both sides with tin-foil, leaving however a space of clear uncovered glass all round; the tin-foil on the side of the glass which is to be outwards is covered with a picture; the underside of tin-foil has a long slip of the same that reaches to the lower part of the frame. To experiment with it:—Hold it by the lower side of the frame—drop a piece of money on the picture—take several sparks from the machine on to the money; then taking hold of the top of the picture, instead of the bottom, direct a person to hold it there with one hand, and having done so, to take up the money with the other. This it will be impossible for him to do, as the moment his second hand approaches the picture he will receive the shock.



MAGIC SQUARE, is a square divided into cells, in which the numbers from 1 to the proposed square are so placed, that the sum of each row, whether taken horizontally, vertically, or diagonally, is equal to a certain given number; thus in the annexed figure, which contains nine cells, the sum of the numbers in each row is equal to 15.

4	9	2
3	5	7
8	1	6

MAGIC VASES. A very amusing electrical instrument; for the purpose at the same time of exploding hydrogen gas, and giving a shock to the person who holds them. B shows the outward appearance of one of the vases. A also the section of the upper part of them. They may be made and used thus:—Procure two strong brass tubes, F G. Let them be about 5 inches long and $1\frac{1}{2}$ internal diameter, open at the bottom, and contracted at the top, so that ordinary corks will fit them. To the lower end of the tubes fit wooden stands or feet, (as represented,) and let a strong wire pass up the centre of the wooden support, and so bent at the top, that the points approach the brass tube, (as at C.) Partly fill both vases or tubes with hydrogen, and cork them carefully; put one on a chain proceeding from the outside of a Leyden jar, D; the other on a chain, E, connected with a discharging rod, and let a person hold the two brass tubes. When the shock is passed, both vases of gas will be exploded, and the person who holds them receive the shock.

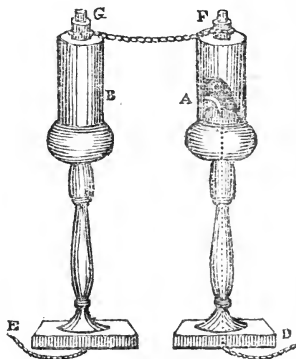

MAGILP. MAGILPH. MEGILPH. A kind of gold size, or thick, tenacious varnish, made for the use of the painter. Linseed oil, boiled with sugar of lead until it is very thick, is recommended by some. Others say, grind 8 ounces each of sugar of lead and rotten stone, with linseed oil, as stiffly as possible. Then melt 16 ounces of white wax, when melted, stir in 8 ounces of spirits of turpentine. Let it get cold, and when it is so, grind it with the rotten stone and sugar of lead. When wanted for use, if too stiff, add turpentine.

MAGISTERY. Chemists formerly applied this term to almost all precipitates, particularly to those of a white color, as the magistry of bismuth. Chemists no longer use the word, but it is still applied by the artizan to a few substances.

MAGISTERY OF BISMUTH. Subnitrate of bismuth.

MAGMA. The general name of any crude mixture of mineral or organic matters in a thin pasty state.

MAGNESIA. One of the earths, having a metallic base, called magnesium. It is a white, soft, light powder, which shows alkaline properties. It is infusible, except by the most intense heat; has no smell and little taste. It is nearly insoluble in water, but combines readily with sulphur, forming a sulphuret; and with the acids forming neutral salts, many of them of great value in medicine and the arts.

MAGNET. A substance endowed with the property of attracting iron, and also of pointing itself in a certain direction. These properties it is capable of communicating to iron and steel bars. Magnets are of two kinds; *natural*, (see *Loadstone*,) and *artificial*. The latter are, according to their shape, known as bar magnets and horse-shoe magnets. (For the method of making artificial magnets, see *Æpinus, Canton, Knight, Mitchell, &c.*) To preserve them, it is necessary to connect together the ends or *poles* with a piece of smooth iron, which is called the *armature*. If of a single bar, it is a *single magnet*; if of several joined together, a *compound magnet*; and if they be cased in brass, it is said to be *armed*. Two points at or near the ends are called the *poles*, and the whole power of the magnet seems concentrated in these points; one is called the *north pole*, and the other the *south pole*. The line which joins the poles is called the *axis*. The following figure, No. 1, represents a natural magnet or loadstone; its usual armature is a piece of iron attached to each end, and a third piece to connect together these two. No. 3 shows a horse-shoe magnet, with a single piece of iron as an armature. No. 2 exhibits two bar magnets, laid side by side, the N pole of one being opposite to the S pole of the other, and a small piece of iron at each end, which connects together the opposite poles of both.

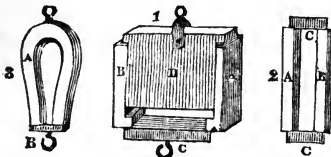

MAGNETIC ALARUM, or more properly *Electro-Magnetic Alarum*. A curious and simple instrument, used to strike an alarum at a great distance, so as to give notice of a telegraph working, starting of a railway train, &c. A A in the cut represents a bar of soft iron, with a long wire twisted round it, terminating in mercury cups. G H are two wires, extending from one station to

another. They may be 50 or 100 miles long, if so required. They are throughout their whole length kept apart, and surrounded with resin, Indian rubber, or other non-conductor, and then inclosed in an iron tube. The farther ends of them are placed in the two cells of a small galvanic battery, the nearer ends resting in the mercury cups G and H. When intelligence is to be given, the long wires are to be united to the battery; when the circuit is complete, the fluid passing round the soft iron will render it strongly magnetic. When it is so, it will draw down or attract the piece of iron B. This, by means of the crank C and the wire D, will raise up the hammer E, so as to strike the bell F. Withdrawing one of the wires from contact with the battery occasions the action to cease; the piece of iron B rising again to its former position, by means of a spring attached to E, or otherwise.

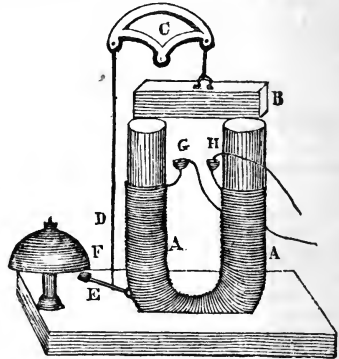

MAGNETIC BATTERY. The same as compound magnet, or a series of simple magnets so united together as to act in concert.

MAGNETIC COMPENSATION PLATE. (See *Barlow*.)

MAGNETIC CURVES. The position in which iron filings arrange themselves from the

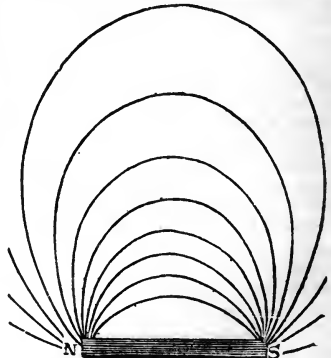

one pole to the other of a powerful bar magnet over which they are sprinkled. The foregoing cut shows their peculiar nature :—

When iron filings are scattered over two similar poles, (as in the next figure over the two north poles of two magnets,) the curves produced are of a different character, and are called *divergent*, the filings not passing in a curve from one to the other pole, but each pole having its distinct system of curves diverging from it, the two systems afterwards crossing each other, leaving little rhomboidal interstices between them.

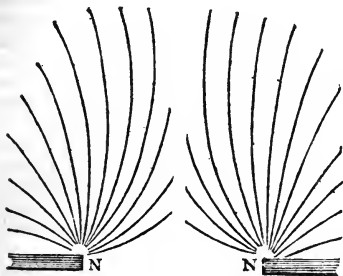

MAGNETIC DECLINATION. Synonymous with the variation of the compass, which indicates the deviation of the magnetic needle from the true geographical meridian, it pointing not to the north and south poles of the earth, but to a point some degrees from it. The amount of this variation is according to the place on the earth's surface where the magnetic needle is situated.

MAGNETIC DIP. A property of the magnetic needle of inclining one of its poles towards the earth, (see *Dipping Needle*.) It differs in different latitudes. The dip at London is about $69^{\circ} 12'$; over the magnetic poles the dip is 90° ; at a line around the earth, forming an equator to these poles, there is no dip.

MAGNETIC EQUATOR. A line around the earth, every where equally distant from both magnetic poles; here the magnetic needle does not dip, but stands horizontally, being equally attracted to both the terrestrial magnetic poles.

MAGNETIC ELECTRICITY. A science compound in character as in name, being the explanation of certain effects produced by the action of a magnet, which so resemble those of electricity as to induce philosophers to believe that magnetism is but electricity in another form, and that the magnetic and electrical fluids are identical.

MAGNETIC FLUID. The property or the fluid which produces those attractive, directive, and other effects, commonly known as magnetic. Some philosophers suppose it

to be a fluid distinct from all others, yet produced naturally by the same causes as those which occasion the development of the electric fluid; others, with apparently more reason, imagine it to be identical with the electric fluid itself; and modern discoveries show that many properties are common to both. The magnetic fluid will, when concentrated, and properly conducted, give a *shock* and a *spark* similar to those which are electrical, and also produce chemical decompositions.

MAGNETIC INDUCTION. The power which a magnet has of communicating the power which itself possesses to bars of iron or steel placed near to it, though not touching. If two magnets are so placed as to affect the same piece of iron, it is called *complex* induction, whether they by their relative position conspire to heighten the effect of the single magnet or to counteract it.

MAGNETIC INSTRUMENTS. (See *Compass, Kater's Compass, Dipping Needle, &c.*)

MAGNETIC MERIDIAN. A vertical circle in the heavens which intersects the horizon in the magnetic poles.

MAGNETIC NEEDLE. A small artificial magnet, balanced on its centre so that it may direct itself in accordance with the magnetic meridian, as influenced to do by terrestrial magnetism.

MAGNETIC POLES, Terrestrial. Two points of the earth to which the poles of an artificial magnet always tend; that in the northern hemisphere, is called the *north* pole; and at the antipodes to this is the *south* pole. The north pole is situated in the north-eastern part of Hudson's Bay, at about 80° west longitude and 60° north latitude. From the great irregularity of the needle in the high northern latitudes, it is inferred that there is a second north magnetic pole, situated at 102° east longitude, with the same latitude as the other pole. If this be proved to exist there will be a second south magnetic pole also.

MAGNETIC SUSCEPTIBILITY AND RETENTIVENESS. The power which some kinds of iron, and more especially steel, has of receiving and retaining magnetic properties.

MAGNETIC SWAN, DUCK, SYREN, FISH, &c. Toys which act upon the principle of magnetism. They are of Dutch manufacture, formed of two pieces of very thin brass beaten into the shape of half the object, and soldered together so as to be water-tight; a darning needle or iron wire is placed within, extending from the head to the tail of the animal. Being so thin, these objects float in water, and are so balanced as to continue upright; a small bar magnet held to one of them will cause it to be attracted and follow the magnet around a basin; a piece of bread, covering the point of the

magnet, makes it appear that the swan, &c. comes to be fed.

MAGNETISM. The science which explains the laws and properties of the magnet.

MAGNETISM, Terrestrial, is that property of the earth from which the magnetism of the ordinary magnets, the direction of the magnetic needle, and other phenomena are derived, and upon which they necessarily depend.

MAGNETO-ELECTRICAL MACHINE. An instrument whereby the magnetic fluid can be procured in a large quantity, and so made to traverse a coiled-up wire, that it presents phenomena exactly accordant with those of electricity; namely, the spark, the shock, the chemical and deflagrating powers, &c. One such machine is described under the word *Clarke*; another, and which is a more convenient form, was previously invented by Mr. Saxton, and is as follows:—

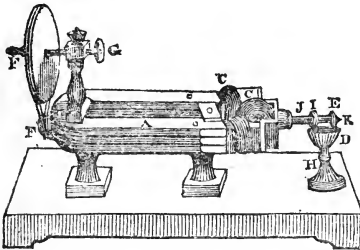

A represents a powerful compound horse-shoe magnet, about 2 feet long. C C C the armature or keeper of soft iron, inclosed in three helices of copper wire, covered with silk. D a wooden cup for holding mercury, moveable by its stem H. E a copper disc, dipping into the mercury, and communicating by a brass socket J with one pole of the helices. I is a slip or cross bar of copper, connected with the other pole of the helices. F a grooved wheel, fixed upon a central axis, which is connected with the armature and coils, to which wheel a rapid motion is imparted by turning the larger grooved wheel F, which is connected with the other wheel by means of a band. G a thumb screw, for adjusting the axis of the wheel F, so as to tighten or slacken the band. Upon turning the larger wheel, it occasions the coils, and with them the armature to revolve rapidly, and in each revolution the slip of metal I, (this may be a starred wheel with advantage,) dips twice into, and of course twice leaves the mercury in the cup; at each of which times the magnet gives a spark, (seen on the mercury,) and also if a contrivance be added so that the human body may be in the circuit between one pole of the helices and the other, a shock will be felt. Thus from the rapidity of motion which may be given to the arma-

ture the shocks so rapidly succeed each other, that they may be considered continuous.

MAGNIFYING, is used to denote the apparent enlargement of an object by means of a convex lens, or some other optical instrument.

MAGNIFYING GLASS. A popular term for any convex glass or lens which has the property of magnifying

MAGNITUDE. The extension of any thing, whether it be in one direction, as a line; in two directions, as a surface; or in three, as a solid.

MAHOGANY. A hard and fine wood, much used in cabinet-making, upholstery, &c. It varies much in quality; that grown on rocks is the hardest, heaviest, closest in the grain, and most beautifully veined. That wood brought from the neighbourhood of Honduras, growing in swampy ground, is light, porous, pale colored, and open grained; and is used for inferior purposes, and for the patterns of wheel-work, &c. That brought from Jamaica, and the more elevated Spanish Colonies, is of a finer and more mottled description, and is generally known as *Spanish mahogany*.

MALEIC ACID. An acid formed when the malic acid is distilled at a heat of 400°. Its salts are called maleates.

MALATES. Salts of the malic acid.

MALIC ACID. An acid which exists in the juices of many fruits and plants, alone, or associated with the citric, tartaric, and oxalic acids. It occasions the sour taste of unripe apples, gooseberries, &c. It has no smell, is in the form of crystals which deliquesce in the air, is soluble in alcohol, and is decomposed at a heat of 348°. It combines with numerous of the bases.

MALLEABILITY. The property of a solid that is hard and ductile, which enables it to be beaten, forged, and extended under the hammer without breaking; as is the case with most metals, gold, lead, copper, and silver especially.

MALT. The chief ingredient of which beer is made, and from which it derives its strength and spirituous qualities. It is made from barley, thus:—The grain is first steeped for 48 hours in a cistern of water; when taken out it is thrown into a heap, where it begins to sprout. Having thrown out its first root, or *acrospire*, to a length of from $\frac{1}{4}$ to $\frac{1}{2}$ an inch, it is spread upon a floor, where becoming dry, the germination ceases. It is finally taken to a kiln, and spread upon a wire floor, under which a clear fire is kept up, until the malt is thoroughly dry, and in some cases partly roasted.

MALTING. The process of making malt.

MALT KILN. A kiln or oven for drying malt.

MANDREL. That part of a lathe to which

the work to be turned is fastened, and which receives motion from the great or fly wheel, by means of a cord. A is the series of pulleys, usually four in number. BC the arbor or spindle, supported at one end by the point of the screw G, and at the other by passing through a hole in the front leg E, and kept in its place by a slight shoulder near C. D is the screw at the nose or front end of the arbor, upon which the chucks that hold the work are fastened. F a support for the screw G. The whole is usually made of iron, with steel collar, &c., and is to be screwed down to the bed of the lathe, immediately over the foot wheel, (if there be one,) so that a cord passing over the grooves of both may turn the mandrel.

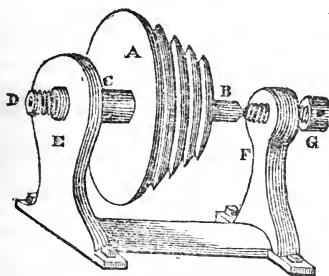

MANGANESE. A greyish white metal, of a fine grained fracture, very hard, very brittle, with considerable lustre; of specific gravity 8.013, and requiring for fusion the extreme heat of 160° Wedgewood. In contact with the air it is converted into a brown, and which afterwards becomes a black oxide. It is this latter oxide, the black or peroxide, which is one of the materials from which oxygen may most easily be obtained, as it gives out a portion of its oxygen at a red heat; also heated with hydrochloric acid, it yields its oxygen to the acid, thus converting it into chlorine. It is used in a very small quantity in the manufacture of imitation gems, (see *Pastes*;) blue enamels, and black pottery ware.

MANGANESIC ACID. One of the combinations of oxygen and manganese; its salts are called manganesates.

MANGLE. A well-known instrument for smoothing linen and similar articles, giving them a polish in consequence of the rolling over them a smooth substance or roller, assisted by a heavy weight placed over it.

MANHEIM GOLD. An alloy, consisting of 3 parts of copper and 1 of zinc.

MANNA. The concrete juice of the *Fraxinus ornus*, a tree much cultivated in Sicily and Italy.

MANOMETER. MANOSCOPE. An instrument intended to measure the rarefaction and condensation of elastic fluids in confined circumstances. The following is a simple contrivance of this kind, invented by Mr. Boyle, and called by him the *Statical Barometer*, or Manometer. It consists of a bubble of thin glass, hermetically sealed, about the size of an orange, which being delicately counterpoised when the air is in a mean state of density, sinks when the atmosphere becomes lighter, and rises as it grows heavier.

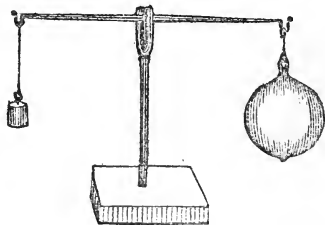

MANTEL. A beam resting on the jambs of a fire-place, to support the brick-work above.

MANUFACTURE. Any thing capable of being made by hand, or manual dexterity, although it may for the greater economy be made or prepared by machinery.

MAP. A plane figure or picture, representing the surface of the earth or a part of it, the same as if viewed from a great height above. If representing a portion of the land, it is called a *geographical map*; if a portion of the sea, a *hydrographical map* or chart.

MARBLE. A variety of limestone, of so compact a texture as to admit of a beautiful polish. The different kinds of marble are infinite. The finest white marble is brought from Italy, and is used for statuary and ornamental work. Marbles are distinguished either from the place they are found in, or from their color. Thus we have Sienna, verde antique, Egyptian, black, black and gold, white, grey, dove, and numerous other species.

MARGARATES. Saline combinations of the margaric acid.

MARGARIC, or MARGAROUS ACID. One of the fatty acids, produced by changing tallow into soap with an alkali, and decomposing the soap by dilute acid.

MARGARINE. The more solid parts of olive oil, and also a constituent in tallow, mutton, &c. It may be procured by drying olive oil on bibulous paper; then dissolving it in ether, and afterwards left to spontaneous evaporation. The white flakes which are deposited are margarine.

MARGARITIC ACID. An acid obtained from castor oil.

MARINE ACID. Muriatic acid; now called the hydrochloric acid.

MARINE BAROMETER. A barometer capable of being so suspended upon gimbals that it always preserves itself erect, not being affected by the motion of the vessel.

MARINE SALT. Common domestic salt, or chemically, chloride of sodium, or more popularly muriate of soda.

MARINER'S COMPASS. (See *Compass*.)

MARKING INK FOR LINEN. Dissolve nitrate of silver in double its weight of water. Wet the linen first with a solution of pure carbonate of potass, to which has been added a little gum water. When dry, write with the ink.

MARLE. A mixed earthy substance, consisting of carbonate of lime, clay, and silicious sand, in very variable proportions. It is sometimes compact, and at others pulverulent, when dry.

MARLINESPIKE. An iron tool tapering to a point; used to separate the strands of a rope in order to introduce those of another, when they are to be spliced or joined evenly, without knotting.

MARMORETUM. A metallic substance formed of mercury and tin-foil, mixed in such proportions as to become a pasty substance. It is used by dentists for filling decayed teeth. Another marmoretum of a different nature is formed of the white of egg, a little water, and quick-lime pounded together; this similarly applied becomes a hard marble-like substance. In architecture, it is cement or mortar made of equal parts of lime and powdered marble mixed with water.

MARMOR METALLICUM. Native sulphate of barytes.

MARQUETRY WORK. Inlaid work formed of fancy woods, and occasionally enriched with valuable materials. The portions inlaid are cut in the form of birds, flowers, leaves, scrolls, &c. This style of ornament was much used formerly to decorate the fronts of cabinets, the tops of chests, tables, &c. The Italians carried the art to great perfection in the 15th century; so did the

French in the 17th. From France it was introduced into England; the floors of several mansions, at the end of the 17th and beginning of the 18th century being thus constructed. There are floors in the British Museum of this work.

MARS. One of the planets of our solar system, the fourth in order from the sun, and consequently the next above our earth. This planet, which is known in the heavens by his red and fiery appearance, performs a revolution in his orbit in 686 days, very nearly; the rotation on his axis is 1 day, 0 h., 30', 21"; his mean distance from the sun is 142 millions of miles; and his mean diameter 4398 miles, consequently he is about one-eighth the size of our earth. He is attended with an atmosphere, but with no moon. Mars appears to us either globular or gibbous, but never as a crescent; also are often observed white spots or protuberances around his poles, which are supposed to arise from masses of ice accumulating there during the long winter, and which by their whiteness strongly reflect the sun's rays.

MARS. The alchemical name for iron.

MARSH. A flat surface, the soil of which is so far saturated with water throughout the year as to be unfit for culture by the spade or plough, but not so much as to prevent it producing coarse grass and other kinds of herbage. If liable to be overflowed by the sea, it is called a *salt marsh*.

MARSH'S ARSENIC APPARATUS. This little instrument is effectual in detecting the most minute quantity of arsenic in any solution. It is composed of a bent glass tube slightly widened at both ends, one arm of it being 3 or 4 inches longer than the other. Into the shorter arm a small piece of zinc is dropped; a thread should be attached to it so that it shall not quite reach the bottom of the tube. The liquid suspected to contain arsenic has a little sulphuric acid mixed with it, and a portion

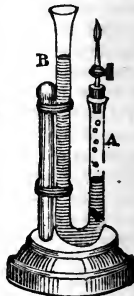

is poured into the arm B. The stop-cock being open, the liquid will fully occupy A; but hydrogen gas being formed by the contact of the acid and zinc this will ascend; and the stop-cock being closed it will accumulate. Upon being let off and a light applied to the jet of the cock, the *arsenuretted* or common hydrogen, as the case may be, will be lighted; if it be the former, that is, if arsenic be present, it will tinge with a purplish metallic stain a piece of glass held close over it; with common hydrogen no stain will be perceptible.



MARSH'S ROTATORY BUCKET. An electro-magnetic apparatus, which revolves when

filled with an acid liquor and placed upon the pole of a powerful magnet. A is the magnet. B C a copper vessel of an outer and inner side, a space of half an inch or so being between them, and having a bottom shaped like a ring; this is made water-tight. D is a short cylinder of zinc, fastened to the upper bowed wire; this is supported upon a point resting in a mercury cup. The vessel A B C is also supported by a wire resting on a point. When in use, the copper vessel, (which should be as thin as possible,) turns in one direction around the pole of the magnet, and the zinc in the contrary.

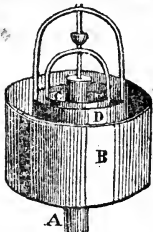

MARSH'S ROTATORY FLOATING APPARATUS. This is an improvement upon the invention of De Rive,

(see *De la Rive*.) That required to be floated in a basin of acidulated water; this contains within itself the acid, and requires to be floated in common water only, and that only for the sake of giving it freedom of motion. A is a coil of wire. B the end of the glass tube C C. Within B are seen two circles, one within the other; the outer is a circle or strip of copper without a bottom, and within this, at D, is a strip or circle of zinc; they both descend into the glass tube, which is filled with acid and water. E E is a cork which floats the whole. The glass tube may be dispensed with altogether; and a silver or copper thimble used instead; this will hold the acid, and a wire of zinc inside will excite sufficient galvanic action.

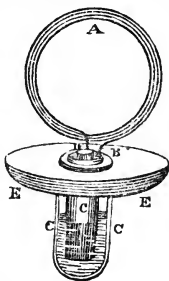

MARSH'S THERMO-ELECTRIC RECTANGLES, consist of two rectangles of fine wire crossing each other, the lower side of each being of platinum wire, the other sides of silver wire; they are united together and

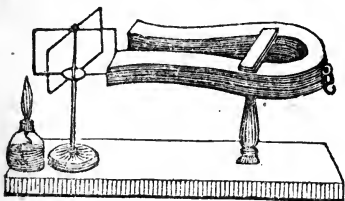

balanced on a point. When this little apparatus is put close to the poles of a powerful horse-shoe magnet, and heat from a spirit lamp be applied to one corner, where the metals join, the apparatus will revolve with rapidity.

MARSH'S VIBRATORY WIRE. An electro-magnetic instrument, showing the effect which a magnet has upon a freely-suspended wire, which is conveying a current of electricity. Its construction is as follows:—A copper wire, with a loop to it, is suspended from a hook A, and is free to move in every direction; the hook A is also a wire terminated by a mercury cup. The lower end of the suspended wire dips into a little channel cut into the wooden stand; to the bottom of the channel leads another wire, leading to a second mercury cup B. A small quantity of mercury being put into the channel of the stand completes a metallic connection throughout, the suspended wire being allowed to dip into the mercury in the channel. If a little mercury be placed on the hook A; and if the two cups and these be connected with a galvanic battery, the wire would conduct the fluid, but without being itself visibly affected; but when a strong magnet is placed with its poles near to the end of the wire, it is immediately thrown up, until leaving the mercury surface the circuit is rendered incomplete, when it falls again only to be thrown up a second time, and thus a vibratory motion is established.

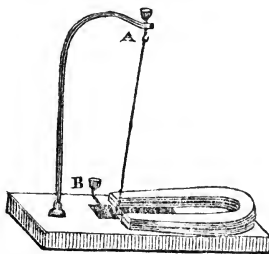

MARTIAL. Belonging to iron.

MARTIAL ETHIOPS. The protoxyde of iron, obtained by moistening iron filings slightly with water, and exposing them for a day or two to the air. A quantity of black or protoxyde forms upon the surface.

MARTIAL REGULUS. An alloy formed by melting together 1 part of iron filings with 2 parts of antimony.

MASONRY. Any kind of stone-work. If composed of exceedingly large rough stones, not united by mortar, it is called *cycloptian*, as the Egyptian temples, and many Druidical remains in this country; if formed of stones of irregular shapes and sizes, it is called *rubble*; if long or square stones were placed

angularly, it is called *herring-bone*; if smooth and flat, *ashlar*; if roughly hewn into a square form, and pitted with holes, it is *rock masonry*; if chamfered at the edges, it is called *rusticated*.

MASS. The quantity of matter in any body, which is always proportioned to and may be estimated by its weight, whatever be its figure or magnitude.

MASSICOT. The yellow oxyde of lead; it is used as a pigment by the painter.

MASTERMAN'S STEAM ENGINE. This is an engine of the rotatory kind, which possesses much simplicity, and is especially to be noted on account of its valves, which have since its invention, (1820,) been called *Masterman's Valves*. The following figure is a transverse section of this steam wheel. A B C D, &c. are weights at the end of short levers, which open and shut the valves during the revolution of the wheel. S S is a steam-tight ring, divided into six or more compartments by the valves. Each of these chambers has a communication with one of a like series of perforations surrounding the axis of the wheel, by the radiating arms or channels, E, F, G, H, &c. This series of perforations revolves with the wheel against a fixed plate, which has *three* openings or perforations; one leads to the condenser, one to the boiler, and the other to the cistern of water. The moveable series of perforations are brought in rotation opposite each of the three perforations in the fixed plate, consequent in every rotation of the wheel; each arm and chamber will communicate in turn with condenser, water column, and boiler. In the position shown in the figure, the moveable opening of arm G is opposite the condenser; the opposite arm, (hid by the stand,) will be therefore connected with the water column. When steam from the boiler is allowed to pass through G, it will fill the chamber connected with it, and prevent the water rising on the side where there is no valve to oppose it, and if of still greater

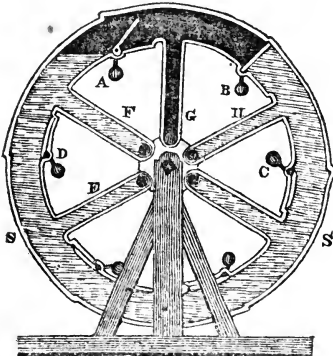

elasticity will force it up on the other side, from the valves being made to open in that direction only. The pipe G communicating with the condenser, the column of water on the circumference of the wheel being relieved from the pressure of the steam will rise to a height corresponding to the condensation that takes place; this gives a preponderance to one side of the wheel, which brings other arms into the same position, so that a continuous motion is generated.

MASTIC. A resin procured by making incisions in the bark of the *pistacia lentiscus*, a tree cultivated in the Levant. It is in yellow, brittle, transparent, rounded tears, which soften between the teeth, with bitterish taste and aromatic smell.

MASTIC VARNISH. Mastic resin dissolved in strong spirits of wine. It is quite transparent, colorless, and dries quickly. It is a good varnish for pictures and small cabinet-work.

MATERIALS. The different kinds of bodies or substances used in the construction or manufacture of any thing. It differs from tools or machines in being materially altered or consumed in the operation of the artisan; thus, fir wood is the material from which pitch is made, the wood at the same time being consumed. Coal is the material of which gas is manufactured, here the coal is not wholly consumed, but greatly changed in properties.

MATHEMATICS. The sciences which treat of the ratio and comparison of quantities. Mathematics are divided into two classes: the one called *pure* and *abstract*; the other *compound* or *mixed*. Pure mathematics relate to magnitudes generally, simply and abstractedly. To this class belong *arithmetic* or the art of computation; *geometry* or the science of measurement and extension; and *analysis*, *fluxions*, or the comparison of magnitudes generally. Mixed mathematics are those parts of natural philosophy, which are by their nature susceptible of mathematical investigation, such as astronomy, optics, mechanics, the laws of motion, &c. &c.

MATHEMATICAL. Relating to mathematics.

MATHEMATICAL COMBINATIONS. A name given by Messrs. Thorowgood and Besley, the type founders, to various ornamental pieces of type, so cast that they will fit each other in different ways, yet form a continued line or surface. They are particularly adapted for the borders of cards, ornamental hand-bills, &c. The examples, and detached pieces, will explain their nature, observing that there are several different patterns of type, and that the combinations which they will form are endless. The invention is French, and all the largest English type founders have adopted the idea. The examples bear the

names of the casters. Some type founders call them *changeable borders*.



This example is composed of the following six pieces, some of them repeated as required. It is evident to what a variety and extent of combination even a few pieces may be carried.



The other example is a border of a lighter character, and therefore better adapted to small and delicate work. It is composed of a repetition of only four distinct pieces of type.



Although the above contains but four patterns, yet the founder supplies the six following; thus fancy and taste may exercise themselves to the utmost.



MATRAS, or MATTRASS. A thin flask or bottle, with a thin egg-shaped bottom and long neck, much used for digestions in chemical researches.

MATRICE. A mould, particularly for the casting of small articles in metal, such as types.

MATRIX. The earthy or stony matter which accompanies ores, or envelopes them in the earth; also a mould for any thing.

MATTER. In philosophy and the arts, is generally understood to mean that solid, inert, divisible substances, accessible to the senses, of which all bodies whatever are composed.

MAUGHAM'S BLOW-PIPE JET. The appended cut is a section of this excellent jet, which is adapted to the oxy-hydrogen blow-pipe. It is screwed by the end A to a gasometer, containing oxygen, while the flexible tube B is connected with the gasometer of hydrogen. The cocks near A and B regulate the supply of the gases. These

gases after passing through their respective tubes meet in a square chamber near to the jet. Through this part of the apparatus a wire passes gas tight, (yet capable of motion.) To the upper end of the wire, the cylinder of lime F, (for the lime light when wanted,) fits, and may be turned about by the lower end of the wire. The terminating jet is for this purpose bent at an acute angle as D E; though other jets for other purposes may be substituted.

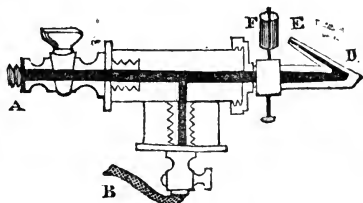

MAXIMUM AND MINIMUM. In a variable quantity or effect, that which is the greatest possible, under the circumstances in which it is placed, is called the *maximum*. Thus in respect to the sails of a windmill, they may be placed at any angle, but there is one angular direction in which the wind will have more power than in any other, it will produce therefore the maximum at this angle. There are other cases in which we seek for a *minimum*, that is the least possible. In mathematics, they are the greatest and least value of a variable quantity, and the method of finding these greatest and least values, is called the method of maxima and minima.

MEAN. A middle state between two extremes; thus we say mean distance, motion, time, &c. An *arithmetical* mean is half the sum of any two quantities; thus 8 is the mean between 2 and 14. A *geometrical* mean is the square root of the product of any two quantities; therefore 4 is the geometrical mean of 2 and 8. An *harmonical* mean is double a fourth proportional to the sum of two quantities and the quantities themselves. Thus if $2 + 3 : 3 :: 2 : 1\frac{2}{3}$ —this multiplied by 2 or $2\frac{2}{3}$ is the harmonical mean.

MEASURE. Any determinate quantity, used as a standard with which others may be compared in space, time, quantity, velocity, &c. The measure of an angle is the number of degrees, minutes, &c. contained in the arc of a circle comprised between the two legs which form the angle, the angular point being the centre. Common measure in vulgar fractions is any number that will divide both terms of the fraction without remainder. The measure of a line is its length compared with some determinate line, such as a mile, foot, inch, &c. The measure of a

surface is the number of square miles, feet, inches, &c. contained on it. The measure of a *solid* is the number of cubic inches, feet, &c. it contains. *Measures*, in commerce, are of certain denominations; those chiefly used in this country are *long*, *land* or *square*, and *cubic* or *solid* measure. One for liquids, called *wine* measure; *dry* measure for dry goods; that of *time*: and one for *angular* measurement, in degrees, minutes, &c.

MEASURING. The art of finding the exact quantity, extent, or capacity of any thing.

MEASURING GLASS. A glass vessel used to measure small quantities of liquid, less than the usual commercial measures can ascertain. Some are made so small as to measure any number of drops, called therefore *drop glasses*; others, drams up to 16 in number; while those of the large size may measure ounces to half a pint, or more in quantity.

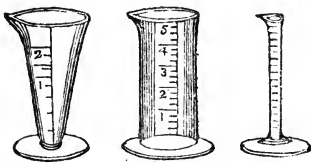

MEASURING TAPE. A piece of tape, of from 10 to 100 feet in length, marked on one side with feet and inches, and on the other with links and rods. It is rolled up in a box for the convenience of carriage. Used in land and house measuring.

MEASURING WHEEL. (See *Perambulator*.)

MECHANICAL. Relating to mechanics.

It also is used as opposed in meaning to scientific or mathematical, as we speak of a mechanical contrivance, a mechanical method of solving a problem, &c.

MECHANICAL CARPENTRY. That part of the art of construction in timber, which treats of the proper disposition of framing, so as to enable it to resist its own weight, or any additional load or pressure that may be laid upon it.

MECHANICAL CURVE. A curve of such a nature that the relation between the abscissa and ordinate cannot be expressed by an algebraic equation: such curves are now generally called *transcendental* curves.

MECHANICAL FORCE. The power of any machine or mechanical contrivance. It may be said to be the measure of all other force, as it bears reference to the effect produced: thus steam, water, man, and horse-power are all represented by the amount of mechanical force they can exert.

MECHANICAL PHILOSOPHY. The science of mechanics; applied to physical inquiries,

or on the other hand, the application of the laws of general science to the improvement and construction of machinery.

MECHANICAL POWERS, are the simple instruments or elements, of which every machine, however complicated, must be constructed. They are the *lever*, the *wheel* and *axle*, the *pulley*, the *inclined plane*, the *wedge*, and the *screw*.

MECHANICS, is that science which investigates the nature, laws, and effects of motion and moving powers. It teaches the construction of machinery, and the adaptation of materials for required purposes.

MECHANISM. The construction and employment of machinery.

MECHANIST. One acquainted with the laws of mechanics.

MECHLORIC ACID. A compound of meconia and chlorine.

MECONATES. Salts of the meconic acid.

MECONIC ACID. A peculiar acid which exists in opium. It crystallises in transparent and micaceous scales of an acid taste; soluble in 4 parts of hot water, and in alcohol.

MEDALLION. In architecture, a circular tablet, on which are embossed figures, busts, and other ornaments. In the fine arts, it is a large medal or coin, stamped to commemorate a particular event, or in honor of some distinguished person.

MEDALLURGY. The art of striking medals and other coins.

MEDICAL ELECTRICAL JAR, is the same in principle as the ordinary Leyden jar, used for electrical purposes; the difference consisting chiefly in the arrangement of the parts for the greater convenience of electrifying a patient, when such an application is required medicinally. It is, in fact, two Leyden jars connected so together that the one or the other may be used according to the strength of shock required. B is a common Leyden jar, holding about a quart, and having a brass hook, F, at the bottom of it, connected with the outer coating.

A is a glass tube open at both ends, lined partly inside and out with tin-foil, there being about two inches of glass at each end uncovered. This is fitted into the wooden cover of B, and has a brass ball at the top, terminating with a hook E, and pierced with two holes, through which pass two wires C and D. The wire C reaches only to the tin-foil within the tube A, and is bent so as to touch it. The wire D reaches to the bottom of B. When the short wire only is in, the shock, or as it is then called,



from its trifling character, the *vibration*, proceeds only from the tube; but when both wires are in, the shock is given from the larger bottle.

MEDIUM. Denotes that space or region through which a body passes in its motion towards any proposed point, being used in contra-distinction to a vacuum, which is a simple void space. Thus air, water, glass, &c. are media of different densities, and possessed of different powers of refraction, resistance, &c.

MEDIUM, Ethereal. (See *Æther*.)

MEERSCHAUM. A white mineral of a somewhat earthy appearance, always soft, but adhering to the tongue. It is not uncommon in Asiatic Turkey. The Turkish pipes are mostly made of it. Pipe-bowls are imported into Germany from Turkey. The Germans soak them first in tallow, and then in wax, to give them a transparent, alabaster-like appearance.

MEGAMETER. (See *Micrometer*.)

MELANIC ACID. A black coloring matter which has been observed in urine.

MELLITIC ACID. An acid discovered in a mineral called mellite or honeystone.

MELLON. A new compound of carbon and azote, discovered by M. Liebig. By heating bi-sulpho-cyanide of mercury, the mellon remains at the bottom of the retort in the form of a yellow powder.

MELLONI'S THERMO-ELECTRIC PILE, consists of 50 small bars of bismuth and antimony, placed parallel, side by side, forming one close bundle A B, the first and last bars having wires to them, E F, which reach to the binding screws G H, where are two other wires that are connected with a galvanometer. The bars are bound together by a ring C, which is supported by the stand D. The two ends of the bundle of bars are blackened. The bars of bismuth which succeed alternately those of antimony, are soldered at their extremities to the bars of the latter metal, and separated from each other at every other part of their surfaces by some insulating substance, such as paper or silk. When one end of the pile becomes warmer than the other, even to a very small

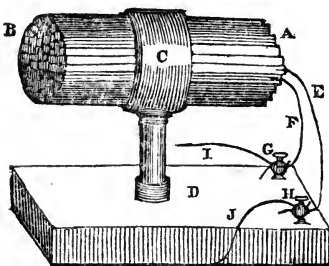

degree, it is indicated by the galvanometer, showing that heat, under certain circumstances, produces an electric effect.

MELTING POINT. That point of the thermometer which indicates the heat at which any particular solid becomes fluid, is termed the melting point of that solid.

MEMBER. A part of any thing, as the members of a steam engine are the boiler, cylinder, piston, &c.; of an edifice, the columns, fascia, pediment; &c.

MEMNON, Statue of. A celebrated statue of King Memnon, erected in Egypt, which had the peculiar property of uttering sounds at particular times of the day. At sun-rise it gave a melodious sound like the twang of a wound-up harp string. This music was said to have been produced by the rays of the sun when they fell upon the statue. At the setting of the sun, and in the night, the sound was mournful.

MENISCUS. A lens which is convex on one side and concave on the other. (See *Lens*.)

MENISPERMIC ACID. An acid which has been extracted from the berries of the *cocculus indicus*, or as it is now called *menispermum cocculus*.

MENSTRUUM. A solvent or dissolvent; any fluid that possesses the property of dissolving or separating the parts of solid bodies.

MENSURABILITY. The capacity of being measured.

MENSURATION. That part of mathematics which is employed in ascertaining the extension, solidity, and capacity of bodies; synonymous with measuring.

MENYANTHIN. The peculiar principle of *menyanthes trifoliata*, or bog bean.

MEPHITIC AIR, or MEPHITIC ACID. Carbonic acid gas.

MERCAPTAN. MERCAPTUM. Mercaptan is another name for hydro-sulphuric ether, which Dumas considers as a *binhydro-sulphate of carbon*. Zeise regards it as a hyduret of a certain compound base, which he calls mercaptum.

MERCATOR'S CHART. (See *Chart*.)

MERCURIAL CUP. A cup-shaped piece of wood, with a wire through the lower part. The object of it is to hold a small quantity of mercury, and thus to furnish the means of a complete metallic communication between one part and another of an electromagnetic apparatus. A small quantity of mercury being put into the cup, and meeting the end of the wire, previously brightened, attaches itself to it; a second wire, with mercury attached to it in the same way, is dipped into the top of the cup.



MERCURIAL THERMOMETER. A ther-

ometer which is supplied with mercury, rather than with spirits of wine, or other fluid.

MERCURIAL TROUGH. An instrument used for the collection of such gases as are absorbable by water, and to which, therefore, the ordinary pneumatic trough is inapplicable. One great object in the construction of mercurial troughs is to have them effective without requiring a large quantity of mercury. The following is one of the *best* construction—the part which holds the mercury is made of cast iron:—

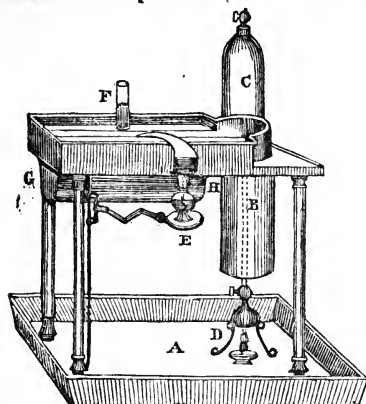

A is a tin trough, in which the instrument stands. B is a gas-holder, into which a gas jar C, may be dipped. D is a vessel in which gas is being generated; it ascends through the mercury within the gas-holder to the jar above. E and F are a lamp, (moveable up and down,) retort, and small jar, for making a small quantity of gas only. G H is a trough lower than the square frame at top, in the upper part of which is a long channel holding mercury, terminating at one end in the gas-holder.

MERCURIUS DULCIS. An old name for calomel, or the proto-chloride of mercury.

MERCURIUS VITÆ. Hydrated protoxide of antimony, called also formerly Algarotti's powder.

MERCURY. The planet which is nearest to the sun, his mean distance being 36 millions of miles. He revolves on his axis in 1 day, 0 h., 5', 28", and his year consists of about 116 days. His diameter is about 3123 miles, and the light and heat he receives from the sun is six times greater than by our planet. He changes his phases like the moon, but generally appears to us like a small crescent.

MERCURY. A metal which is fluid at common temperatures. It freezes at 39° below zero Fahr., and boils at 656°, at which heat it passes off in vapour. Its specific gravity

is 13.6, and it has an exceedingly bright silvery appearance. It combines with great readiness with certain metals, such as gold, silver, zinc, tin, and bismuth, forming in certain proportions fluid solutions of these metals: such mercurial combinations are called amalgams. This property is extensively used in many arts, such as separating gold and silver from their ores, gilding, plating, making looking glasses, &c. Mercury also combines with sulphur, forming cinnabar or *vermillion*. It is also soluble in numerous of the acids, forming compounds highly useful in medicine and the arts.

MERIDIAN. In astronomy and geography, a great circle of the sphere passing through the zenith, nadir, and poles of the world, crossing the equator at right angles, and dividing the sphere into two hemispheres, the one eastern, and the other western. When the sun is in the meridian it is noon in all places situated under it. There are as many meridians as there may be conceived points in the equator. In effect the meridians always change, as the longitude of the place varies, and may be said to be infinite; each respective place, from east to west, having its respective meridian. The *first* meridian is that from which all the rest are accounted, reckoning from west to east. The first meridian is the beginning of longitude.

MERIDIAN ALTITUDE. The height of the sun, moon, &c., above the horizon, when it crosses the meridian of a place. The meridian altitude of the sun therefore will be his altitude at noon day.

MERIDIAN OF A GLOBE, OR THE BRASS MERIDIAN. The brass circle placed vertically around an artificial globe from pole to pole. It is graduated into four quadrants of 90° each, and is used by means of this graduation to ascertain the latitude of places. It also acts as a universal meridian, to which if any place be brought, its longitude may be known by the degree of the equator, which may come at the same time under the brass circle.

MERIDIAN, Magnetic. (See *Magnetic*.)

MERIDIAN LINE, OR NORTH AND SOUTH LINE, is a line drawn upon a flat surface, such as the ground, so that it may be due north and south. An upright object, therefore, placed on the line will, at exactly 12 o'clock each day throughout the year, supposing the sun to shine, cast a shadow exactly along the meridian line. On a dial it is of course the line that points to noon.

MERIDIAN, OR MERIDINAL DISTANCE. The same as difference of longitude or distance between the meridians of two places.

MEROS. The plane face between the channels of the triglyphs of the Doric order.

MESOLABE. An ancient instrument for finding two proportionals between two given numbers.

METAGALLIC ACID. An acid produced by heating the gallic acid in a retort, at a temperature not exceeding 410° or 420° . It is black, shining, tasteless, insoluble in water, but soluble in liquid ammonia, potass, and soda.

METAL, Fusible. (See *Fusible Alloy*.)

METALLIC THERMOMETER. Synonymous with pyrometer, (which see.)

METALLIZATION. A changing into metal, a term particularly applied to ammonia when combined with mercury by electrical influence. When mercury is negatively electrified in a solution of ammonia, or when an amalgam of potassium and mercury is placed upon moistened muriate of ammonia, the metal increases in volume, and becomes of the consistency of butter, an appearance which has been called the *metallization of ammonia*.

METALLOIDS. A name given by Berzelius to certain simple substances. They are sulphur, phosphorus, carbon, boron, and silicon. The metallic bases of potassium, sodium, and the other alkalis and earths, have been by some also called metalloids.

METALLURGY. The art of extracting metals from their ores.

METALS. By far the most numerous class of undecomposed bodies in chemical arrangements. They amount to 42, all more or less remarkable for a peculiar lustre, called the metallic. They are excellent conductors of heat, and most of them of electricity. All combine with oxygen, but with affinities and in quantities extremely different; some of them becoming alkaline, others acid. Combining with each other they constitute alloys, or when mercury is one of the metals employed, the compound is an amalgam. They unite also with some of the other simple bodies, forming sulphurets, hydrurets, phosphurets, &c.; and are soluble in numerous acids, constituting a class of salts of various properties, but mostly existing in a crystalline frame.

METAMECONIC ACID. An acid procurable by boiling the meconic acid. It is this latter acid deprived of part of the carbon which it contains, that being dissipated by the heat. Its salts are metameconates. They are of no known use.

METAPHOSPHORIC ACID. A term by which some chemists designate the dry flaky acid, obtained by burning phosphorus under a bell glass of air or oxygen.

METEOR. A term applied by some authors to denote all the various phenomena of the atmosphere, while others apply it exclusively to denote those luminous bodies which appear at a considerable height above the earth. They sometimes proceed in this hemisphere from north to south with vast velocity, frequently breaking into several smaller ones,

sometimes vanishing with a report, sometimes not. Considering meteor in its extended sense, as including all atmospheric transitory phenomena, it is necessary to divide them into classes, according to their origin or nature. Thus winds, whirlwinds, &c., are *aerial* meteors; dews, fogs, rain, snow, and other depositions or disturbances of the water of the atmosphere, are called *aqueous* meteors. Many arise from the refraction or reflection of light from the aqueous particles suspended in the air—these are called *luminous* meteors, such are halo, mirage, rainbow, &c. While those that present the appearance and phenomena of combustion are *igneous* meteors, such are falling stars, lightning, the aurora borealis, &c.

METEORIC STONES. METEORITES. (See *Aeroliths*.)

METEOROLOGY. The science which treats of meteors, the state of the weather, &c.

METHYLENE. A peculiar liquid compound of carbon and hydrogen, extracted from pyroxilic spirit, which is reckoned to be a bi-hydrate of methylene.

METONIC CYCLE. A cycle of 19 years, at the end of which time the new moon occurs on the same days of the year, and the eclipses return in nearly the same order. The reason of this is, that in 19 solar years there are 235 lunations; and very nearly one complete revolution of the moon's nodes.

METOPÉ. The space between the triglyphs on the Doric frieze, often ornamented with sculpture.

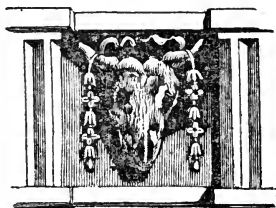

METRE. The French standard measure of length, equivalent to 39.371 , or very nearly $39\frac{3}{8}$ English inches.

METRONOME. An instrument for measuring time in music. It is contrived on the principle of a clock having a short pendulum, whose bob being moveable up and down on the rod, is thus capable of increasing or decreasing the length of a note or bar, as indicated by the character of the music. The stem or pendulum rod is marked with all the same characters that indicate musical time, so that the instrument may be set as required.

MEZZOTINTO. A particular mode of engraving on copper. The sheet of copper is first scratched over and over in every direction, with an instrument made for the pur-

pose, till the face of it be wholly covered with lines or scratches, so close to each other, that if an impression were taken from it, it would be one uniform blot or smut. This being done, the design is marked on it; after which the engraver proceeds with burnishers, scrapers, &c., to take out the furrows in those places where the lights are to be, leaving more or less black those parts that are to remain in shadow. It is the most expeditious mode of engraving.

MIASMATA. Vapours or effluvia, which by their application to the human system, are capable of exciting various diseases. Some miasmata are generated in the human body, and being given off by it, and intercepted by a second human body, propagate those disorders known as infectious, such as plague, typhus fever, &c. Other miasmata arise from marshes, decaying vegetable matter, &c., occasioning various intermittent and other fevers. These latter act at a much greater distance than the former kind.

MICA. A transparent mineral, mostly of a greyish color, which under the name of *talc*, or *Muscovy glass*, is used for the panes of windows; the fronts of some furnaces; the top of the mariner's compass; and more especially, when split into exceedingly thin slices, instead of glass, for mounting microscopic objects.

MICROCOSMIC SALT. A salt extracted from human urine. It is a phosphate of soda and ammonia. It may be prepared otherwise by mixing together solutions of equal proportions of these salts, and evaporating so as to crystallize the salt.

MICROMETER, is an instrument fitted to telescopes, microscopes, &c., in the focus of the object glass, for measuring small angles or distances, as the apparent diameters of a planet, part of an insect, vegetable fibre, &c. Several forms have been given to the micrometer. A piece of glass, covered with fine wire, spider's web, &c., so that the fibres shall intersect each other at exact and previously determined distances, forms one of the simplest micrometers. Another kind, called the *wire micrometer*, is that which is usually appended to telescopes. It is formed as follows:—A A is a brass box, seen as if cut in two, longitudinally. H H are two micrometer screws, which move the forks or staples I and N backwards and forwards, one sliding evenly within the other. Across the forks are two fine wires C and E, the inner fork having a cut along it to allow the wire of the other to pass; this being placed in a hole cut in the eye tube of a telescope, exactly in the focus of the lenses, the screws are to be turned until the wires exactly embrace the diameter of the object to be measured. To ascertain this apparent diameter, multiply the size of the thread of the screw by the number of turns requisite to

bring the wires to touch each other: the product will be the distance of the wires, and consequently the measurement required. Other micrometers are described under the words *Brewster* and *Herschel*.

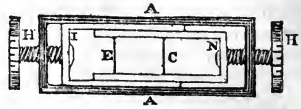

MICROMETRICAL EYE-PIECE. (See *Ramsden*.)

MICROMETER-PYROMETER. (See *Smeaton*.)

MICROMETER SCREW. A fine screw, with a large head, attached to various parts of philosophical instruments and delicate machinery, for the purpose of marking very minute differences of length or distance. Its usual construction will be understood by what follows:—

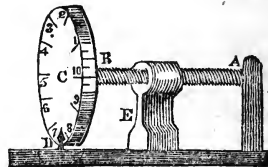

A B is a very fine screw, perhaps of fifty threads to the inch. It is supposed to pass through a screwed socket at E, which socket is capable of motion backwards and forwards along a groove beneath. The screw at the end A abuts on a projecting piece, where it is fastened, so that it can turn round, but not draw out. The end B is furnished with a large head, the margin of which is divided into ten or more equal parts. A fixed stud D is fastened to the frame below. Suppose a screw of this description be attached to the reflecting lens of a Newtonian telescope. It may be adjusted with great accuracy and facility. Turning the head wholly round with the thread of the screw such as we have supposed, it would move the socket E, and with it the lens attached, the fiftieth of an inch, but turning the head a tenth part only, moves it but the five hundredth of the same measure. A screw of this kind without the margin graduated is called a *tangent* screw. Were E fixed, the screw would move A backwards in like manner.

MICROSCOPE. An optical instrument for viewing small objects, rendering those visible which cannot be distinguished by the naked eye, and magnifying those that can. The form of microscopes is very numerous, but they may all be included in two distinct classes; namely, *single* microscopes, and

compound microscopes; the latter, either reflecting or refracting. A single or simple microscope, is that which consists of a single lens or spherical globule, fitted-up so that it may be conveniently held to the eye, the object being at the focus of the lens. A common hollow globe of glass, an inch in diameter, and filled with water, is of itself a single microscope; so would be a drop of water placed upon a hole drilled in a thin piece of brass. The following is a frequent and convenient form of this instrument:— A is a piece of thick brass, with a channel cut along it, to enable B with the objects attached to slide towards or away from the lens. C is a pair of nippers to hold the object. D is a brass socket and screw holding the glass, (magnifying or double convex lens.) E the handle to hold the instrument by. There is often in the socket D two lenses, one at each side. These being combined and acting only as a single lens, without requiring focal adjustment with each other, or complexity in the instrument, it still retains the character of *single*.

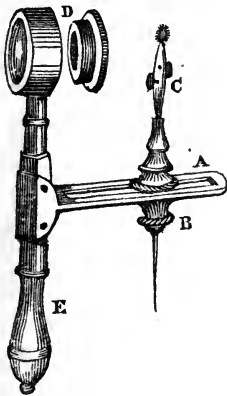

The compound microscope is very varied in its form. One of the most convenient is called the pillar microscope. It does not, like some others, require to be looked down into, but may be turned by the screw at the top of its pillar into any position convenient for the eye of the observer. A is the body of the instrument containing the lenses. B is the stand, which has three feet, folding under each other, when the instrument is not in use. C is a square socket, moving up and down by the joint on the top of the pillar. D E is a square bar of brass sliding along through the socket C. At the end D is a cross arm supporting the body A. At G is a second socket moving along D E to support the object holder and apparatus, the position of which is adjusted by

the thumb screw at G. I is the reflector. F is the object holder, shown with a slider of objects within it. H is a second reflector, to be taken off or put on, as required. This is used when opaque objects are to be examined.

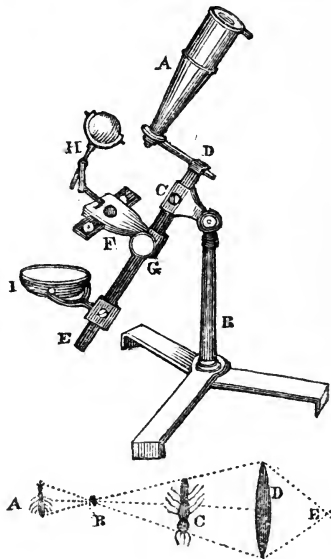

The lenses requisite to the instrument are shown beneath. The light from the object A is thrown upon a small double convex lens B. By this the rays are converged, and form a magnified image of the object at C. The rays of light still passing forward, strike the second lens D, where they are converged a second time, and consequently increase the magnitude of the image still more, previously to its entering the eye at E. The eye seeing the *image* of the object and not the object itself, as in the former instance, constitutes this a compound microscope. For other microscopes, or parts of them, (see *Culpepper, Gould, Opaque Cups, Test Objects, &c.*)

MICROSCOPIC OBJECTS, are those which are too small to be distinctly seen by the naked eye. The most interesting microscopic objects are the sections of wood, the various parts of insects, the infusoriæ, the pollen, stomata, and vessels of plants; the crystals of salts, hairs of animals, scales of fish, slices of fossils, &c.

MICROSCOPIC OBJECTS, *Machine for Cutting of*. Those microscopic objects which consist of the cuttings of woods and similar objects, require an instrument for the purpose of cutting them. The following is one which is at the same time convenient and efficacious:—A represents a solid table of brass,

about 6 inches long, 4 wide, and a quarter of an inch deep, with a guide or stay-piece rising above the general surface at the back edge B. C is a hole through A, fitted with a short cylindrical socket, that extends below the under surface of A: it is close at the bottom, except that the screw passes through it. The head of this screw is made by a toothed wheel E, containing 10 teeth, while the screw itself contains 30 threads to the inch. The use of the screw is to move up or down a brass cylinder, with a square hole in it; the top of this is seen at D. The wheel E is kept in its place by the spring F. II is a three sided brass frame, which has a sharp razor blade across it at J. K is the wooden stand to the whole. When used, the wood to be cut is fixed tightly into the square hole D; the socket put into its place, and adjusted by the screw below. The knife being then pushed forward will cut off a slice of wood: upon turning the wheel one tooth, and again moving the knife, a second slice will be obtained, and so on. These sections, if good, should float in spirits of wine.

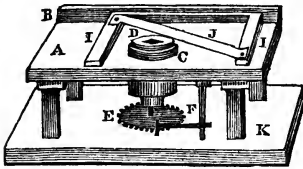

MICROSCOPIC OBJECTS, Mounting of. Transparent objects for the microscope may be fastened upon strips of glass, by means of Canada balsam, warming the glass previously to its application. This will render objects extremely transparent and beautiful. Ordinary objects may be placed loose between two circular pieces of talc, cut very thin and punched to a proper form and size. They are then put into shallow holes cut in a piece of ivory, and retained in their places by a ring of wire; the holes have a very slight shoulder left to them to prevent the talc falling out on the other side.



Opaque objects, such as small portions of minerals, are placed upon a round piece of thin soft leather, punched out in circles of about $\frac{3}{8}$ of an inch diameter, the leather being previously covered with paper. A pin run through the leather holds the object conveniently.



MIDDLE LATITUDE. (See *Latitude*.)

MIDDLE LATITUDE SAILING. (See *Latitude*.)

MIDDLE POST OF A ROOF. Synonymous with king post. (See *Roof*.)

MIDDLE QUARTERS, OF COLUMNS. When the plan or horizontal section of a column is divided into four quadrants, by lines not at right angles to the front, but at an angle of 45° , the four quarters are called the middle quarters.

MID-HEAVEN. The highest point of the heavens, reckoning from one side of the horizon to the other; called also the nonagesimal, or 90th degree.

MILE. A measure of length, consisting of 1760 yards. It is the same measure as was used in this country by the Romans. The Scotch and Irish miles are longer by about one-quarter. A sea mile is the 60th part of a degree, or $2027\frac{1}{2}$ yards. The miles of various countries differ very materially.

MILK. A well-known, nutritious, white fluid, secreted in the mammillary glands of female animals, and intended to nourish their offspring while yet too young to take solid food.

MILK, Sugar of. When the whey of milk is evaporated, it deposits a sweet crystallised substance, called the sugar of milk.

MILK OF LIME. (See *Lime*.)

MILK OF SULPHUR. Sulphur deposited from its alkaline solutions by an acid. It is in the form of a yellowish, grey, impalpable powder.

MILKY WAY, Galaxy, or Via Lactea. A broad and irregular zone of stars that surrounds the heavens, so distant that their united light gives but an indistinct and undefined whiteness to the whole appearance, whence its name.

MILL. A machine employed in grinding or pulverising any substance, as that of grain, whereby it is formed into flour, which is usually accomplished by rubbing it between two harder bodies, consisting generally of stone, and termed *mill-stones*—the operation of turning these stones being effected by water, air, human or animal power, or machinery; hence the terms *water-mill*, *wind-mill*, *hand-mill*, *horse-mill*, &c. Mills are also distinguished by the purposes to which they are applied, as bark mill, flour mill, oil mill, cotton mill, saw mill, &c.; from which it will be evident that the term mill is applied to a great variety of machines besides those of grinding. Also all descriptions of wheel-work at the present time are known by the general name of *mill-work*, or *mill gearing*, originating no doubt from the circumstance of this being one of its first applications.

MILL, Barker's. (See *Barker*.)

MILL GEARING. The general arrangement and formation of large wheel-work.

MILL HEAD. The head of water which is to turn a mill.

MILL TAIL. The water which has passed below or over the wheel of a water-mill.

MINARET. A small turret or tower attached to Mahomedan buildings, provided with one or more external balconies, from which the Mahomedans are called to prayers by the voices of the priests.

MINDERERUS'S SPIRIT. A solution of acetate of ammonia; obtained by saturating distilled vinegar with the carbonate of ammonia.

MINE. A term applied, generally, to underground works or excavations, when made for the purpose of obtaining metallic ores and other minerals. The approach to a mine, if perpendicular like a well, is called a shaft; if horizontal, an adit. Coals and salt are found in beds; metals in veins, called *lodes* or *courses*, and only found in *primitive* rocks; they usually run from east to west.

MINERAL. A general term, including all inorganic substances, or those that constitute the earth itself; such therefore are earths, stones, metals, sulphur, and similar bodies, in all their varieties of combination, as well as in an uncombined condition.

MINERAL ADIPOCERE. A greasy bitumen found in the argillaceous ores of iron.

MINERAL ALKALI. Soda.

MINERAL ANALYSIS. That part of chemistry which explains and ascertains the composition of mineral substances.

MINERAL CAOUTCHOUC. The elastic bitumen found at Castleton, in Derbyshire.

MINERAL CAMELEON. (See *Cameleon*.)

MINERAL CHARCOAL. Coal, peat, or other mineral, having had its gaseous particles driven off by partial burning or scorching, and left in the state of *coke*.

MINERAL GREEN. Carbonate of copper, obtained by precipitating a hot solution of sulphate of copper by carbonate of soda.

MINERAL PITCH, *Maltha*. A solid bitumen, otherwise called asphaltum, (which see.)

MINERAL TALLOW. A white, bituminous, and greasy substance, of the consistence of tallow. It is very rare, but has been found in Finland, and in the rocky parts of Persia.

MINERAL TAR. The same as petroleum; a brownish black, oily, bituminous fluid, which is found in the earth, and dropping from rocks in many parts of Europe and Asia; also in the West Indies, whence it is called *Barbadoes tar*.

MINERAL WATERS. This term is applied to certain spring waters, containing so large a proportion of foreign matter as to be unfit for ordinary use. The principal mineral springs of England are those of Harrowgate, and one at Cheltenham, containing sulphur;

another at Cheltenham; one at Bristol, Buxton, Bath, Scarborough; and two at Leamington, containing different saline substances; and those of Tunbridge, Brighton, and a third at Cheltenham, containing iron, and called chalybeate waters. The mineral waters of Germany are numerous, and much celebrated.

MINERAL YELLOW, or Patent Yellow. A compound of oxyde and chloride of lead; obtained by digesting powdered litharge in a solution of common salt—washing, drying, and fusing the product. It is used as a pigment.

MINERALISERS. The substances with which metals are combined in their ores. Thus, in the native oxydes, oxygen is called the mineraliser. Sulphur is also a common mineraliser, as in the ores of copper, lead, &c.

MINERALOGY. That science which teaches the properties, composition, and relations of mineral bodies, and the art of distinguishing and describing them.

MINER'S FRIEND, or MINER'S LAMP. A name which has been given to Davy's lamp, ensuring as it does comparative safety to the miner from the effects of fire damp, or the explosion of carburetted hydrogen.

MINIATURE. A representation of nature on a very small scale. Hence the term *miniature* painting, which is usually performed on ivory or fine card board. The outline being drawn with great delicacy, and the colors used being mixed and tempered with water; a little gum to add brilliancy to the finishing coats, and a minute quantity of ox gall, to take off the greasiness of the ivory, being frequently added.

MINIM. The smallest liquid measure, equal to about a drop. An ounce of liquid contains 480 minims.

MINION. The name of a type. (See *Type*.) Also an iron ore, which mixed with lime and water makes a water cement.

MINIUM. Red oxyde of lead, commonly called red lead.

MINIMUM. The reverse of maximum, (which see.)

MINUS ELECTRICITY. (See *Franklin's Hypothesis*.)

MINUTE. The measure of a sixtieth part of any thing, as the sixtieth part of a degree, of an hour, or of a module.

MINUTIÆ. The minute parts, ornaments, or details of any thing.

MIRAGE, LOOMING, or FATA MORGANA. An aerial phenomenon, occasionally seen in particular states of the atmosphere, in which ships, coasts, mountains, &c., appear as if suspended in the air, as is represented in the following cut, illustrative of a mirage seen by Captain Scoresby in the Greenland seas. He saw the appearance of about 18 or 19

sail of ships at the distance of from 10 to 15 miles. As he viewed them from the mast head, they seemed to change their form—one was drawn out or elongated in a vertical plane; another was contracted in the same direction. One had an inverted image immediately above it, as at A and B; and two had two distinct inverted images in the air, as at C. Along with these images there appeared distinct images of masses of ice in two strata, the highest of which had an altitude of about 15'.

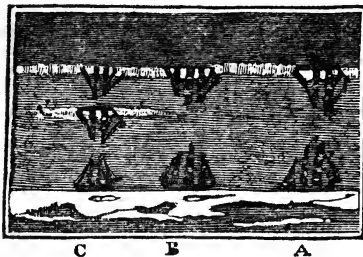

MIRROR. A speculum or polished body, which exhibits the images of objects by reflection. They may be made of glass, covered on one side with a reflective metallic substance, like the common looking glasses; or else made wholly of metal and highly polished. Mirrors are either *plane*, *convex*, or *concave*; these latter are also called burning mirrors. They may of course be of any other form, if required; as for example that of a cylinder or cone.

MISPICKLE. Common arsenical pyrites.

MITCHELLS. Among builders are Purbeck stones, from 15 inches square to 2 feet, squared and hewn ready for building.

MITCHELL'S METHOD OF MAKING MAGNETS, or the **METHOD OF DOUBLE TOUCH.** Arrange on a flat surface, two, three, or more steel bars, to be magnetized. Then take two bundles of strong magnets, parallel to each other, but with the poles of one parcel reversed to those of the other. Then holding these parcels of magnets at a short distance from each other, as represented, rub them several times along the bars from end to end, when they will become strongly magnetic.

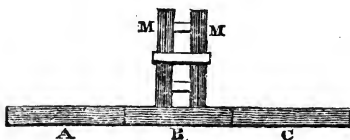

MITRE BOX. A trough for cutting mitres, having three sides open at the ends.

MITRE. A line cut straight across an angle, where two solids meet.

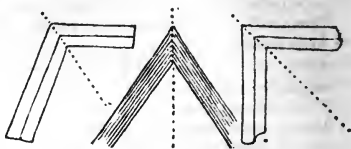

MITRE DRAINS, or CROSS MITRE DRAINS. The drains laid under the surface of roads to convey the water to the side drains. They are usually placed 60 feet apart, and filled up loosely with flints.

MIXED ANGLE. (See *Angle*.)

MIXED FIGURE. One that is composed of straight lines and curves, and yet not a regular geometrical figure.

MOCHO STONE, or MOSS AGATE. A silicious mineral, often cut for brooches, rings, &c., and deriving its beauty from a moss-like branched form being imbedded in its transparent substance.

MODEL. An original or pattern, proposed for any one to copy or imitate. Sometimes reference is made to another already-constructed object; thus we say, that St. Paul's Cathedral was built after the model of St. Peter's, at Rome. At other times, and more frequently, it designates a miniature representation of a building, a statue, carving, ship, &c., made of wood, plaster of Paris, clay, wax, or other plastic material, and intended to convey an idea of the effect which will be produced when the thing itself is built or fashioned of the requisite size. Model in the fine arts signifies generally any thing to be imitated, whether larger or smaller than the proposed copy. Thus, the living figures which the students of an academy of painting imitate in their sketches are called models, and thus we speak of the works of the great painters being models of perfection, &c.

MODELLING. The art of forming models of any kind.

MODILLION. Consoles or brackets, placed under the cornice of buildings. In the Corinthian they are always carved; in the other orders more simple, some of them must always correspond to the middle of a column.

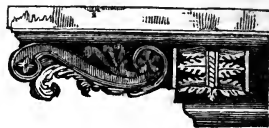

MODULE. In architecture by module is meant any extent taken at pleasure, to measure the parts of a building by, and is usually

determined by the lower diameter of the column, one half of which is a module. It is divided in 30 parts or minutes.

MOHAIR. The hair of the goat of Angora, famous for its whiteness and silky softness. It is manufactured into camlets and expensive stuffs, shawls, &c. Little has hitherto been imported into England.

MOIRRE METALLIQUE, OR CRYSTALIZED TIN. A crystal-like appearance given to tin plate or to the surface of tin foil, when a dilute acid is passed with a sponge or brush over it, and immediately afterwards washed. It is colored with various colored transparent varnishes.

MOLE. The same as breakwater; that is, a rampart of stone, wood, gravel, &c., thrown up and projecting into the sea, for the purpose of breaking its force, and thus rendering a harbour or roadstead more secure from the effect of storms and boisterous waves.

MOLECULE. Denotes one of the minute particles of which any mass or body is composed. Molecules differ from atoms in this, that they are never considered but as portions of some aggregate. Atoms may be imagined to exist alone.

MOLYBDENUM. A peculiar metal, which is white, brittle, very infusible, and of a specific gravity, about 8.6. With oxygen, it forms two oxides and an acid.

MOLYBDIC ACID. Composed of 1 atom of molybdenum and 3 of oxygen. Its compounds are called molybdates.

MOLYBDOUS ACID. A composition of oxygen, 2 atoms, and molybdenum, 1. It is procured by boiling metallic molybdenum and molybdic acid together.

MOMENT. An indefinitely small portion of time, having the same relation to duration as a point has to a line.

MOMENTUM. A force possessed by matter in motion. A steam carriage detached from the engine continues to move for some time by its momentum or the force which its mass of matter has accumulated. The power or quantity of momentum is reckoned by the velocity of its motion.

MONKEY. A weight or mass of iron let fall from a height to drive piles into the earth.

MONOCHROMATIC LIGHT. A light consisting of one color only; for example, burn in a dish a mixture of common salt and spirits of wine. The flame will be so entirely of a yellow color, that the objects around will not be seen in their natural tints, but yellow, like that of the light.

MONOCHROME. A painting of a single color. This art is often practised among artists, as sketches, either in Indian ink or sepia. It was much in vogue among the ancients, particularly the Etruscans. The terra cotta vases of this people still remaining show the extent to which it was carried.

MONOLITHAL. Works constructed of a single stone.

MONOMIAL. In algebra, is a quantity consisting of only one term, as ax , $3xy$, &c.

MONOPTERON, OR MONOPTERAL TEMPLE. An edifice consisting of a circular colonnade, supporting a dome, without any inclosing wall, and consequently without the cell that there is in other temples.

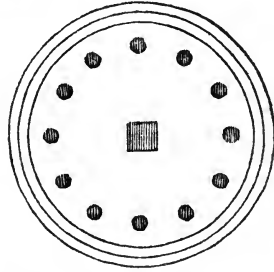

MONOTRIGLYPH. A Doric entablature, in which there is only one triglyph between two adjoining columns. This is the usual practice in the Grecian Doric, as in the Parthenon, or Temple of Minerva, at Athens.

MONSOONS. The name given to certain disturbances of the regular course of the trade winds, which take place in the Arabian and Indian seas. Between the parallels of latitudes of 10° and 30° south, the eastern trade wind blows regularly, but from the former parallel northwards, the course is reversed for half the year, and from April to October the wind blows constantly from the south-west; during the rest of the year the regular north-east trade wind prevails. The S.W. monsoon is supposed to be occasioned by the great rarefaction of the atmosphere over the extensive regions of Eastern Asia during the summer months.

MONTGOLFIER, OR FIRE BALLOON. A name given to those balloons which receive their buoyancy from the burning of combustible materials, being thus denominated after the name of their inventor. Their cause of buoyancy distinguishes them from the *air* or gas balloons.

MONTH. The twelfth part of the year, and so called from the moon, by whose motions it was regulated, being properly the time in which the moon runs through the zodiac, or passes round the earth. A *lunar* month is the time from one new moon to another, or 29 days, 12 h., 44 m., 3 s. A *solar* month is the time in which the sun runs through one entire sign of the zodiac, the mean quantity of which is 30 days, 10 h., 29 m., 5 s. A *civil, calendar, or common* month, is an interval of a certain number of whole days, approaching nearly to the quantity of a solar month.

MONUMENT. A structure raised to preserve the memory of some eminent person, or to perpetuate some remarkable event.

MOON. One of the heavenly bodies; the constant attendant of our earth, about which she revolves as a centre, illuminating us by her reflected rays in the absence of the sun. Her sidereal revolution is in 27 d., 7 h., 43 m. Her synodical revolution in 29 days, 12 h., 44 m., 3 s. Her mean distance from the earth about 237,000 miles. Her velocity varies in different parts of her orbit; she moves swiftest when nearest the earth, and slowest when at the contrary point. The rotation on her axis is uniform, and is performed in the same time as her revolution in her orbit, whence she always presents nearly the same face to the earth. Her figure is an oblate spheroid, like that of the earth. Her mean diameter being about 2160 miles, consequently her volume is about a fiftieth part that of our planet. Her atmosphere, if any, must be extremely attenuated, and looking at her with a telescope we find her surface greatly diversified, being covered with bright spots and lines at one part, and with dark shadows at another. Several planets, besides our earth, are attended by moons—Jupiter has four; Saturn seven; and Herschel six.

MOON, Harvest. (See *Harvest Moon*.)

MOON, Phases of. The different *faces* or appearances which the moon presents to us in her monthly rotation around the earth, are called her phases, and have distinctive names, according to the quantity of the surface of the moon which is at that time visible. The following cut will at once show and explain this. The sun is supposed at an immense distance, sideways of the cut. He would, in that position, illuminate the half of the moon nearest to himself, whatever position the moon might be in with reference to the earth, (except she be exactly behind it, as in the time of an eclipse,) this is seen in the outer circle of the cut; but that illuminated side will only be wholly visible to the inhabitants of the earth at the time of

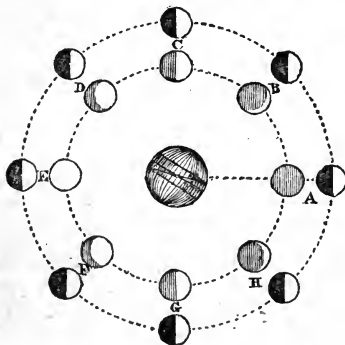

full moon, or full phased moon, as at E. While in the position A, the illuminated side is wholly turned from us, and consequently the moon is invisible. We call it then *new moon*. Three or four days after this a crescent is seen, as at B. Seven days after new moon, she enters her *first quarter*, when half a circle is seen, as at C; afterwards, more than half a circle, when the moon is called *gibbous*, as D. The same changes occur between full and new moon in the other half of the month, but in reverse order, or as in F, G, H.

MOON DIAL. A dial that shows the hours of the night by the light of the moon.

MOON'S AGE. The number of days since the new moon.

MOON'S NODES. (See *Node*.)

MOOR. An uncultivated surface without trees, and with but a scanty and coarse herbage.

MOOR-STONE. A whitish kind of granite, found in Cornwall, Devonshire, Ireland, and some other places. It is brought from the former places in immense masses to London, where it is used for the steps of public buildings, curb-stones, and other purposes, where great strength and hardness are required.

MORDANT. In dyeing and calico printing, denotes a body which, having a two-fold attraction for organic fibres and coloring matter, serves as a bond of union between them, and thus gives durability to dyes; or it signifies a substance which by combining with coloring particles in the pores of textile filaments, renders them insoluble in hot, soapy, and alkaline solutions. The principal mordants are alumina or the earth of alum, tin, and oxyde of iron.

MORDANT VARNISH. (See *Gold Size*.)

MORESQUE. (See *Arabesque*.)

MOROCCO. A goat-skin leather, prepared chiefly in Morocco. It is used in the binding of books, &c.

MOROXYLIC ACID. An acid discovered by Klaproth in the bark of the white mulberry. Its distinctness is much doubted, even by its discoverer. Its compounds are moroxylates.

MORPHIA. A vegetable alkali, extracted from opium, of which it constitutes the narcotic principle. It was first obtained pure by M. Sertürner, about the year 1817.

MORTAR. A cement used for building purposes, composed of lime, sharp coarse sand, and sometimes the hair of animals, all thoroughly mixed together with water, so as to form a half fluid, half solid mass.

MORTAR. A strong hollow instrument, usually made of marble, Wedgewood ware, or metal, in which hard or brittle substances are pulverised by percussion or grinding with another instrument, called a *pestle*. Mortars usually partake of the shape of an inverted bell or cup, but their form, capacity,

and solidity, as well as the material of which they are made, vary with the object for which they are designed.

MORTAR, Electrical, or Electrical Bomb. A small apparatus, intended to show the mechanical effects of electricity, upon the same principle as Kinnersley's air thermometer. The bomb is of ivory, bone, or other non-conducting substance; a ball of light wood fits a semi-circular cavity at the mouth of the bomb, and a small chamber is made beneath it. Two wires, (one at top, the other leading to the stand beneath,) pass into the cavity, and are there separated by a small interval. When a shock is passed through the wires, the air within the cavity is rarefied; its sudden expansion throwing out the ball.

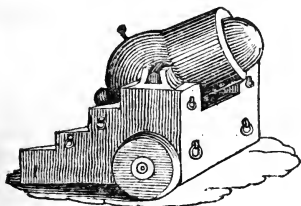

MORTAR, Hydraulic, or Roman Cement. A cement which acquires but little solidity in the air, but becomes extremely hard under water. The poorer kinds of lime stone are burnt, ground, mixed with water and sand, and immediately applied to the work.

MORTICE AND TENON. A description of joint used in wood-work. The extremity of one piece of timber is let into the face of another piece; a tongue being formed at the end of the piece to be let in, which is called a *tenon*, and the hole cut in the face of the other is called a *mortice*.

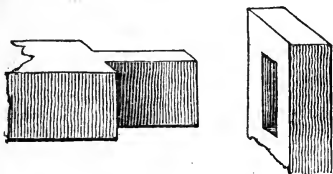

MORVEAU'S PLATINA PYROMETER. The base of this instrument is a small, yet solid plate of highly-baked porcelain, in which is a groove, capable of containing a flat bar of platina, $1\frac{3}{4}$ inches in length, $\frac{1}{10}$ of an inch in width, and about half this in thickness. One end of this rests or abuts against the bottom of the groove; the other presses against the short arm of a bent lever. The long arm of which, moving on a pivot, becomes the index of the instrument. The short arm of this lever is exactly $\frac{1}{20}$ of the

long arm, consequently the space it moves over will be twenty times as great as the expansion of the platinum, or rather as the space passed over by the short arm. There is a finely-divided scale also of platinum attached to the instrument.

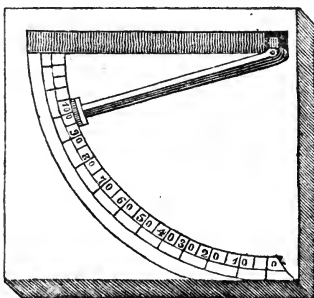

MOSAIC GOLD, or OR-MOLU. A peculiar alloy, formed of equal quantities of copper and zinc, melted together; when in a fused state, about a tenth part more zinc is added to bring it to a proper color, and to compensate for the zinc that may have flown off in fumes. Mosaic gold, (the aurum musivum of the old chemists,) is a sulphuret of tin.

MOSAIC WORK. Representation of animals, flowers, or other objects, formed of small pieces of colored marble, glass, &c. The finer kinds are used upon seals, and in rings and brooches; the larger for the decorations of walls and the formation of pavements. A common kind of mosaic pavement is frequent on summer houses, on terraces, and similar places, made of horses' teeth, sheep's knuckle bones, shells, and small stones, arranged in some fanciful manner. (See *Quarry, Pavement, and Tessellated*.)

MOTHER OF PEARL, is the hard, silvery, brilliant internal layer of several kinds of shells, particularly of the oyster tribe, which is often variegated with changing purple and azure colors. These brilliant hues do not depend upon the nature of the substance, but upon its structure. The microscopic wrinkles or furrows which run along the surface of every slice, act upon the reflected light in such a way as to produce this chromatic effect. Mother of pearl is brittle and very delicate to work, but it may be fashioned by saws, files, and drills, with the aid sometimes of a corrosive acid. It is polished by crocus, the peroxyde of iron, putty powder, &c.

MOTHER WATER. When sea water, or any other solution containing various salts, is evaporated, and the crystals taken out, there always remains a fluid containing deliquescent salts, and other impurities. This is called mother water.

MOTION, or LOCAL MOTION. A continued and successive change of place, which occurs with a body; or, in some cases, the parts of a body when acted upon by an adequate force. Motion is of various kinds:—*Absolute* motion is that which is independent of any other motion, or friction, or retarding power; in which general sense, however, it never falls under our own observation. All those motions which we call absolute, are, in fact, only relative, being referred to the earth, which is itself in motion. For convenience, however, we consider a change of place on the earth's surface, from some certain point of starting, as an *absolute* motion. *Angular* motion is the motion of a body, as referred to a centre about which it revolves. This is the only case in which the parts of a body are in motion, without the whole of it being so. *Accelerated* and *retarded* motions are those which are continually increasing or diminishing in velocity, while *equable* motion continues uniform. *Compound* motion is the result of two or more distinct forces acting together. *Natural* motion is that which arises from the effect of gravitation, or of the centrifugal force. *Relative* motion is the alteration of place between two objects in motion relatively to each other. A *resultant* motion is that which results from the different power of two opposite forces; thus, a steam engine may have a power of six horses, but the friction of the various parts may diminish this two horses; thus, the resultant force or motion will be four horses.

MOTION, Laws of, are as follows, as delivered by Sir I. Newton:—First, every body perseveres in its state of rest, or uniform motion in a right line, until a change is effected by the agency of some external force. Second, any change effected in the quiescence or motion of a body, is in the direction of the force impressed, and is proportional to it in quantity. Third, action and re-action are equal and in contrary directions.

MOVEABLE PULLEY. (See *Pulley*.)

MOVEMENT. The working part of a clock or watch.

MOVING POWER. A force or energy, or impulse, sufficiently powerful to produce motion. It may be the wind, water, animal force, steam, &c.

MOULD. That in which any thing has been or may be cast. According to the material of which a mould is composed, or the purpose to which it is applied, so is its name, as a plaster, sulphur, wax, or sand mould; candle mould, bullet mould, &c.

MOULDING. An ornamental line, either projecting or depressed. In classical architecture, and for ordinary embellishment, the following are the most common:—A, *astragal* or *bead*; B, *ogee*; C, *cymatium*; D,

cavetto; E, *scotia* or *casement*; F, *apophyses*; G, *ovolo* or *quarter-round*; H, *torus*; this is larger than a bead, and differently placed; I, *reeding*; J, *band*; and last, the *fillet*, which is a small square member that generally accompanies the other mouldings. (See the above terms.)

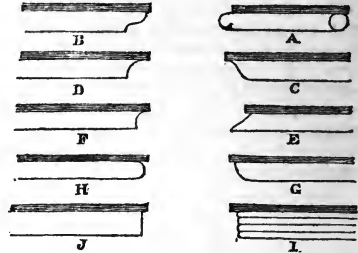

In Gothic work, mouldings are extremely varied, some peculiar to a particular age or style; others, common to a long period. See *Chevron*, *Nail-head*, *Billet*, *Scollop*, *Tooth*, *Trefoil*, *Quatrefoil*, *Roll*, *Ball Flower*, &c. The following shows a series of plain mouldings, forming a Gothic cornice:—

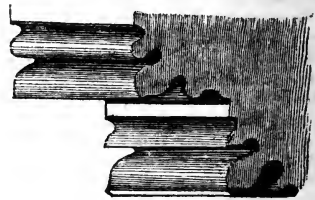

MOUNTAIN BLUE. Malachite; a carbonate of copper. Used as a pigment.

MOUNTAIN CORK and MOUNTAIN LEATHER. (See *Asbestos*.)

MOUNTAIN GREEN. A carbonate of copper.

MOUNTAIN MILK. A very spongy soft variety of carbonate of lime.

MOUNTAIN SOAP. A soft, pale, brownish black kind of unctuous chalk, found in the Isle of Skye; used in crayon drawing.

MOUNTAIN, or ROCK WOOD. (See *Asbestos*.)

MOYA. Mud poured out of volcanoes.

MUCIC ACID. The same as saccholactic acid. It may be obtained by digesting one part of gum arabic or of sugar of milk, with twice or thrice its weight of nitric acid.

MUCILAGE. An aqueous solution of gum.

MUFFLE. A small earthen oven, made of crucible clay of the following form. It is to be fixed in a furnace, and is useful for cu-

pellation and other smelting processes which demand access of air.



MULLER. A tool employed in pounding and grinding substances upon a stone. The glass grinders thus call the instruments used for grinding their glasses, which consists of a round piece of wood, about 6 inches long; to one end of which is cemented the glass to be ground. For grinding colors, the muller is of stone, and is usually employed upon a flat slab of stone.

MULLIONS. Upright stone divisions of a window.

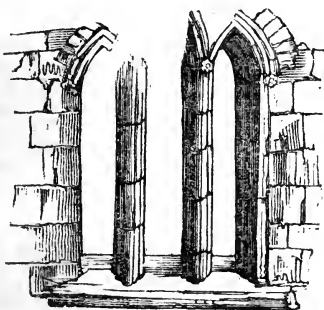

MULLIN'S VOLTAIC SUSTAINING BATTERY. This useful instrument of research has been frequently confounded with Daniel's constant battery, but they are essentially different; the latter, though constant, not sustaining or keeping up an equally powerful current of electricity for any period required, which perfection has been attained by the former. Its mode of arrangement and elements of power also materially differ; the zinc surface being brought within three-eighths of

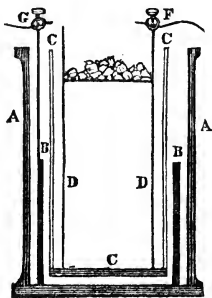

an inch of the copper in the sustaining battery, whereas in the constant battery the interval between the metallic surfaces amounts to an inch and half; also, in Mullins's invention no acids are used, which is the case in Daniel's. The accompanying diagram will explain more fully the arrangement of the parts:— A A is an earthenware pot. B B a cylinder of zinc, *not* amalgamated, about half the height of the pot. C C C a diaphragm of wood, properly prepared. D D a cylinder of copper, without a bottom. E shelf for holding crystals of sulphate of copper, communicating with the external surface of the copper cylinder, by small holes on a level with the upper surface of the shelf. F wire and binding screw connected with the zinc cylinder. G the same, connected with the copper. To charge this battery, take equal parts of a saturated solution of ammonia and soft water, and having first inserted the wooden diaphragm, pour the mixture into the pot, between the diaphragm and the zinc, until it stands at three-fourths of the height of the pot, and into the diaphragm pour a saturated solution of sulphate of copper, until the solution rises to half an inch above the level of the shelf E. It is to be observed, that when the battery is not in use, the wooden cylinder should be removed, and kept in water in which some common salt has been dissolved. For all purposes of electrotype this battery possesses great advantages, as from its equality of current there is a more equal and firmer deposition of copper or other metal than with any other form of battery.

MULLIN'S VOLTA-ELECTROMETER. In this useful invention a slip of platina foil is wound round the elongated bulb of a thermometer, on the scale of which the degrees are subdivided into fifths. The ends of the foil are connected with binding screws, which unite them to the poles of the battery. The quantity of electricity is ascertained by the heat developed in the platina foil during the passage of the current, as shown by the thermometer. A A is a stand, to which the thermometer is affixed. B the bulb of the thermometer, with the foil rolled round it. C the thermometer. E D the binding screws, connected with the foil; and also with the battery.

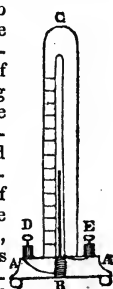

MULTINOMIAL. In algebra, a quantity consisting of more than three terms, as $x^4 + ax^3 + a^2x^2 + a^3x + a^4$.

MULTINOMIAL THEOREM, is a general expression or formula, for determining any power or root of a given quantity consisting of any number of terms.

MULTIFOIL. A leaf ornament of more than five divisions.



MULTIANGULAR. Having many angles.
MULTILATERAL. Having many sides.

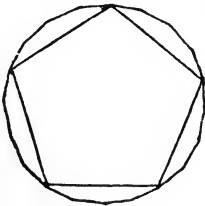

MULTIPLE. In arithmetic, is a number which contains another number a certain number of times: thus, 18 is the multiple of 6, or of 3, or of 9, &c. The common multiple of two or more numbers is that which contains them both a certain number of times: thus, 36 is the common multiple of 4 and 9, being equal to 9 times the first, and 4 times the second.

MULTIPLE POINTS. In analytical geometry, when two or more branches of a curve pass through the same point it is called a multiple point.

MULTIPLICAND. (See *Multiplication*.)

MULTIPLICATION. One of the principal rules in arithmetic and algebra; and consists in finding the amount of a given number or quantity, called the *multiplicand*, when repeated a certain number of times expressed by the *multiplier*; and this amount is generally termed the product; also the multiplier and multiplicand are commonly termed factors. Multiplication is either *simple* or *compound*; simple multiplication is when the proposed quantities are integers or whole numbers; compound multiplication implies that one of them is a compound quantity; that is, one consisting of several denominations, as pounds, shillings, and pence.

MULTIPLICATION TABLE. A small table, containing the product of all the simple digits and onwards up to 12 times 12, or occasionally up to 24 times 24. Its use is to facilitate operations in arithmetical multiplication.

MULTIPLIER, OR MULTIPLICATOR. The number by which another is multiplied. (See *Multiplication*.)

MUTIPLIER, Galvanic. (See *Galvanometer*.)

MULTIPLYING GLASS. A plano-convex lens; the convex surface of which is cut into numerous faces, each of which reflecting the light differently gives the appearance of very numerous objects, (such as candles or fires,) being before it when it is looked through.

MUNDIC. The name given by miners to copper pyrites.

MUNNIONS. (See *Mullions*.)

MURAL. Connected with a wall, as a mural monument, a mural column, &c.

MURAL ARCH. A wall or walled arch, placed exactly in the plane of the meridian, for the fixing of a large quadrant, sextant, or other instrument, to observe the meridian altitude of the heavenly bodies.

MURDOCK'S STEAM ENGINE. This is upon the rotatory principle, and extremely simple. A and B are two wheels, working into each other, and turning in a box, to the inner circumference of which the ends of the wheels are made to move round steam-tight by packings or stuffings. The axis of one or both of the wheels passes through the sides of the box, and is made steam tight in the usual manner. Steam being admitted into this box by the pipe or channel G, and a vacuum being formed by the condenser H, the steam acts upon the teeth of the wheels, and causing them to turn round in contrary directions, produces a rotatory motion, which may be communicated by means of the axis to other machines.

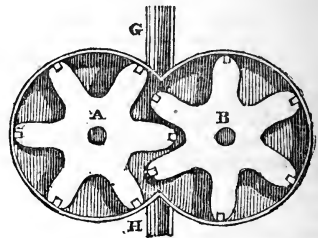

MURIATES. Synonymous with chlorides, or compounds of the hydrochloric acid with salifiable bases.

MURIATIC ACID. (See *Hydrochloric Acid*.)

MURIATIC ACID GAS. Chlorine in a gaseous state; when combined with water it becomes the muriatic or hydrochloric acid.

MUSCOVADO SUGAR. Synonymous with the common brown, raw, unrefined sugar of our shops.

MUSCOVY GLASS. (See *Mica*.)

MUSICAL, or HARMONICAL PROPORTION.
(See *Harmonical*.)

MUSK. A strong perfume, obtained from an animal of the same name. It is much used in perfumery.

MUSLIN. A fine sort of cotton cloth, first imported from India, but now mostly manufactured in this country.

MUST. The juice of grapes, composed of sugar, water, jelly, gluten, and bitartrate of potass. New and unfermented wine, of whatever fruit it may be made, is also called must.

MYRIAD. The number 10,000.

MYRICINE. A vegetable principle, which constitutes from 20 to 30 per cent. of bees'-wax, being the residuum when alcohol is poured on that substance.

MUTULE. A flat square block, placed on the soffit of Doric cornices, answering to the modillions of the Corinthian order, and to corbels in the Gothic. Guttæ are most generally cut on the under surface.



MYRRH. A gummy, resinous, concrete juice, which issues by incision, and sometimes spontaneously, from the trunk and large branches of a tree growing in Arabia and Egypt. It consists of two-thirds resin and one gum.

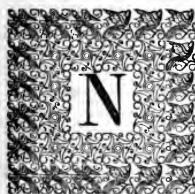

The fourteenth letter, eleventh consonant, and third liquid of the English alphabet. It has something of a nasal sound, as in *finger, tinker, &c.*, and is pronounced chiefly by the action of the tongue against the lower gum, much like the letter L. It readily unites with other letters, as in *send, rant, tongue, tank, lynx, &c.* In Latin and Greek, the N is often omitted, as *mesibus* for *mensibus*. As a numeral it signifies 90, or with the Greeks it stood for 50. As an abbreviation it indicates *noster*, as N. D., *dominus noster*; also *novus, nobilis, &c.* In geometry and astronomy it signifies *north*.

NACRE. A name given to mother of pearl.

NADIR. That point of the heavens which is diametrically under our feet, as opposed to the zenith, which is the point directly over our head. The zenith and nadir are the poles of the horizon.

NAIL-HEAD. A peculiar Norman Gothic ornament, which consists of the resemblance of a series of square-headed nails, such as the following:—



NAILS. Small metallic spikes, used for fastening the parts of wood-work together, and similar purposes.

NAIRNE'S ELECTRICAL MACHINE. The same as the cylinder machine, but with a second prime-conductor attached to the cushion for the collection of the negative

fluid. (See *Cylinder Machine*.) The earlier of Nairne's machines were made without this, and with the usual prime-conductor placed at right angles to the cylinder. It was of tin, and instead of wire points, had them cut like teeth out of the edge of the tin itself.

NAKED. Uncovered; the bare surface of a wall, which serves as a ground for the projections.

NAKED FLOORING. The assemblage of timbers or joists upon which flooring boards are placed.

NANCEIC ACID. A name given by Braconnot to the lactic acid.

NANKIN. A peculiarly colored cotton cloth, originally manufactured in the above named ancient capital of China, from a native cotton of a brownish yellow hue.

NAOS. The chamber or inclosed apartment of a temple.

NAPHTHA, or ROCK OIL. A transparent yellowish or brownish fluid, of strong penetrating odour, greasy to the touch, and so light as to float on alcohol. Near Baku, on the borders of the Caspian Sea, are fountains of it. The ground also at Pitchford, in Shropshire, is saturated with it; but the principal source whence it is now obtained is from the distillation of coal tar. It is, chemically speaking, a hydro-carbon, not containing any oxygen in its composition; thus, it is useful to keep in contact with potassium, sodium, and other substances, which would be decomposed by contact with the air. Its chief employment, however, is for lamps, in which it burns with a brilliant light.

NAPHTHALINE. A peculiar, white, crystallisable substance, which may be extracted by distillation from coal tar. It is a solid bi-

carburet of hydrogen. It has not been applied to any use.

NAPIER'S BONES, or RODS. A method contrived by Lord Napier for the more easily performing the arithmetical operations of multiplication and division. These rods are five in number; made of bone, ivory, wood, horn, or paste-board. Their faces are divided into nine little squares, each of which is parted into two triangles by a diagonal. In these little squares are written the numbers of the multiplication table in such a manner as that the units or right hand figures are found in the right hand triangle; and the tens, if any, in the left hand triangle. One of the rods has only the units upon it. The following cut shows the five rods. The other sides of them are covered with the rest of the multiplication table in like manner, up to nine times inclusive, with one for the cypher. To multiply numbers by *Napier's bones*, dispose the rods in such a manner that the top figures may represent the multiplicand; to the left hand place the rod of units; in which seek the right hand figure of the multiplier; and the numbers corresponding to it on the other rods, write out, adding each two together as you go on. Then proceed with another figure of the multiplier in like manner, and finally add together the several lines thus found—as in common multiplication. The rods in the following cut are arranged as if the multiplicand were 2345; to multiply this by 8, we shall have first to put down the right hand figure in the line of 8, which is 0; then we shall have 4 and 2 added together, or 6; afterwards 3 and 4 added together, or 7; then 2 + 6, or 8, and finally 1, which is in the other half of the first square, and the whole product will be these numbers collected together. 18760.

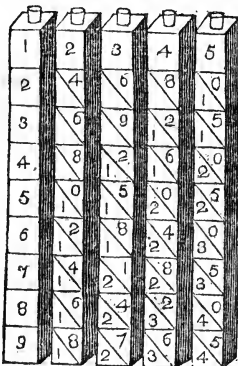

NAPLES YELLOW. A yellow colored pigment, prepared by calcining lead with

antimony and potash in a reverberatory furnace.

NARCEIA. An alkaloid discovered to exist in Turkey opium.

NARCOTINA. An alkaloid extracted from opium. It may be obtained by dissolving opium in warm ether; as this cools, it will deposit crystals of narcotina.

NATIVE. In chemistry, mineralogy, &c., signifies that which is naturally produced, in opposition to which is made artificially—as the native carbonate of lime, native cinnabar, native copper, &c. In the last case it implies that the metal is in a metallic state, and not in combination with sulphur, lime, acids, &c., when it would constitute an ore, and not be considered native.

NATRIUM. The name given by the German chemists to sodium, the metallic base of soda.

NATRON. The native sesqui-carbonate of soda. It is found in vast abundance in the lakes near Alexandria, in Egypt. It is also found in many parts of North America, Asia, Europe, &c.

NATURAL BEDS OF A STONE, are the surfaces from which laminae may be split. For example, slates are split only in one direction, which is in accordance with the natural beds in which they are found.

NATURAL MAGNET. (See *Loadstone*.)

NATURAL PHILOSOPHY, or EXPERIMENTAL PHILOSOPHY, is that branch of knowledge which explains the laws and facts of physical nature by means of experiments. As such, it is distinguished from moral or ethical philosophy, which treats only of the working of the mind and imagination. To natural philosophy belong the sciences of chemistry, mechanics, hydrostatics, hydraulics, pneumatics, electricity in its various branches, magnetism, astronomy, heat, optics, &c.

NAVE. The central division of a cathedral church, extending from the west end to the choir.

NAVE. The central boss, or *hub*, as it is in some places called, of a wheel through which the axletree passes, and which receives the inner ends of the spokes.

NAVIGATION. The art of sailing or conducting a vessel on the ocean.

NAVIGATORS. The name given to men employed on canals, railways, &c.

NEALING. (See *Annealing*.)

NEAP TIDES. (See *Tides*.)

NEBULE. An architectural ornament of a

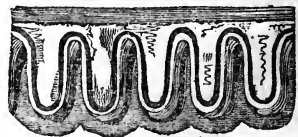

zigzag form, but without angles. It is almost peculiar to Saxon and Norman buildings.

NEBULÆ. In astronomy, faint luminous spots in the heavens, some of which consist of clusters of telescopic stars, others appear as luminous spots of different forms.

NEBULOUS STARS. A name given by Dr. Herschel to those stars which are surrounded with a faint luminous atmosphere of considerable extent.

NECK OF A COLUMN. That part of the shaft between the annulet and the capital above.

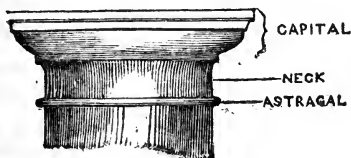

NECK MOULDINGS. Those around the lower part of a capital in classical architecture.

NEEDLE, Dipping. (See *Dipping*.)

NEEDLE, Variation of. (See *Magnet*.)

NEGATIVE. In algebra, arithmetic, &c., the reverse of positive, as negative index, exponent, quality, &c., are such as are indicated by the mark — which is called the negative sign, and which signifies less than nothing; as -5° on Fahr. thermometer, indicates that the temperature is five degrees below zero or cypher. So, again, in algebra, $a - b$ is read *a minus b*, and signifies that the quantity b is to be subtracted from the quantity a .

NEGATIVE ELECTRICITY. (See *Franklin's Hypothesis and Electricity*.)

NEGATIVE AXIS OF DOUBLE REFRACTION. When a ray of light passes through a crystal which has the power of double refraction, (see *Carbonate of Lime*); one ray or appearance is called the *ordinary* or *natural* ray, the other, the *extraordinary* ray. If this extraordinary ray be refracted towards the axis of the crystal, the axis is called *positive*; if it be refracted away from the axis, it is called a *negative* axis of double refraction.

NEROLI. The name given by perfumers to the essential oil of orange flowers.

NERVES. In architecture, the mouldings of the groined ribs of Gothic vaults.

NET. A trellis-like fabric of threads or cords, chiefly used for entrapping fish, birds, and other animals. The term is likewise applied to a particular branch of manufacture, of a fine open texture, usually applied to the purposes of dress.

NEUTRALIZATION. The state produced, when acids and alkaline matters are com-

bined, in such proportions that neither predominates, as evinced by the color of the tincture of litmus, or of cabbage remaining unchanged by the combination.

NEUTRAL SALT. A combination of an acid, with either an alkali, an earth, or a metal; of such a nature, that the two bodies exactly neutralise each other, so that there may be no preponderance of either. Most salts are of this nature. (See *Salts*.)

NEWCOMEN'S ENGINE. (See *Atmospheric*.)

NEWEL. The column round which the stairs of a staircase wind.

NEWMAN'S MERCURY TROUGH. (See *Mercury Trough*.)

NEWTONIAN PHILOSOPHY. The doctrine of the universe, and particularly of heavenly bodies, their laws, affections, &c., as delivered by Sir Isaac Newton.

NEWTON'S FUSIBLE METAL. (See *Fusible Metal*.)

NEWTON'S TELESCOPE, OR NEWTONIAN REFLECTOR. This reflecting telescope consists of a concave parabolic mirror A fixed at the end of the tube D D. The plane speculum C is fixed to a wire, having its outer end attached to a dove-tailed sliding piece I I; and the face of the plane mirror is inclined to the axis of the tube; and the large speculum at an angle of 45° . In the sliding piece I I is inserted a short tube to hold an eye-piece, which is a single lens with its flat side outermost. The rays of light from the object pass into the telescope at R R. They pass onward along the tube to the large speculum, and are here reflected to C, and thence to the eye-piece.

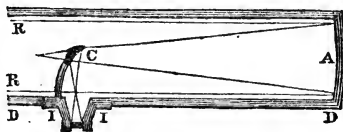

NIC. Protoxyde of nickle.

NICARAGUA WOOD, is an inferior red wood, used with a solution of tin to produce a bright but fugitive red color upon silks and cottons. It is the wood of the *cæsalpinia echinata*.

NICKLE. A metal usually associated in its natural state with cobalt. It is always present in meteoric stones. It has been much used of late years as the principal metal in the alloy called German silver. It possesses a fine silvery white lustre, is hard, but malleable both hot and cold, and ductile. It is susceptible of magnetism.

NICOTIANINE. The name of an oil extracted from tobacco leaves, which possesses the smell of tobacco smoke, and is a highly dangerous narcotic poison.

NICHE. A hollow space cut in a wall to hold an image or statue.

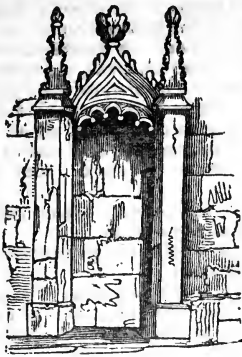

NICOTINE. A peculiar principle obtained from the leaves and seeds of tobacco by infusing them in acidulous water, evaporating the infusion to a certain point, adding lime to it, distilling, and treating the product which comes over with ether. A single drop of it will kill a dog.

NIGHT. That part of the natural day in which the sun is below the horizon, from which is sometimes deducted a portion of morning and evening, called twilight. Thus, in the middle of the summer it is said that we have no real night, although the sun is below the horizon for nearly eight hours, because he never descends so low that we entirely lose his light; the evening twilight not terminating before that of the morning commences.

NIGHT TELESCOPE. This is a telescope of the simplest of all constructions, consisting merely of a tube, in which is inserted two convex lenses, at a distance from each other equal to the sum of their focal lengths, such as is seen in the following diagram, where A B represents the outer tubes, one sliding within the other, for the adjustment of the focus for near or distant objects. C is the object lens. D the eye-piece or lens. E F G rays of light proceeding from the object to the eye. H the focus of both lenses, and at which point an inverted image of the object is formed.

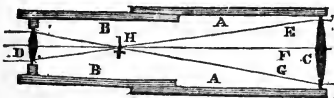

NIHIL ALBUM. A name formerly given to the white oxyde of zinc.

NILOMETER. A column or obelisk erected on the banks of the Nile and marked with

the divisions requisite for ascertaining the height attained by the waters of the river.

NIMBUS. A showery or rain cloud.

NITRATES. Compounds of the nitric acid, with various salifiable bases.

NITRE. The usual name given to the nitrate of potass or saltpetre.

NITRIC ACID. An acid of a highly corrosive nature, composed of nitrogen 1 part, and oxygen 5 parts. It is, when pure, colorless and fuming, the fumes being also colorless. It tinges the skin yellow; dissolves and unites with most of the metals, and all the earths and alkalies; forming nitrates. It may be procured by the distillation of nitre with sulphuric acid.

NITRIC OXYDE. (See *Nitrogen, Deutoxyde of.*)

NITRICO-OXYDE OF MERCURY. When the nitrate of mercury is exposed to heat, gradually raised to dull redness, nitric acid is given off, and a red substance remains, consisting of peroxyde of mercury, with a small portion of adhering nitrate. This is the nitrico-oxyde.

NITRITES. Combinations of the nitrous acid with the salifiable bases, alkalis, earths, and metals.

NITRO-ÆRIAL PARTICLES. Oxygen being discovered as a constituent of the air, and resembling the nitrates in assisting combustion, was considered, as in some degree, an analogous substance, and, therefore, was at first called "The Nitro-ærial particles of the air."

NITRO-CARBURETS. A name proposed by Brande to be substituted for cyanides.

NITROGEN GAS, or AZOTE. A gaseous element which is permanently elastic, destitute of color, taste or smell. It extinguishes all flame, and when unmixed with oxygen is fatal to animal life, yet it constitutes 79 hundredths of the bulk of atmospheric air. It is disengaged from the earth in numerous places, from all animal and many vegetable substances, when in a state of decomposition. It may be obtained artificially by burning phosphorus in a jar of oxygen, the pyrophosphoric acid having subsided, the jar will be found to contain nearly pure nitrogen. It unites with oxygen in many proportions:—

Nitrogen 79	Oxygen 21	forms atmospheric air.
do. 1	do. 1	do. nitrous oxyde.
do. 1	do. 2	do. nitric oxyde.
do. 1	do. 3	do. hyponitrous acid.
do. 1	do. 4	do. nitrous acid.
do. 1	do. 5	do. nitric acid.

NITROGEN, Deutoxyde of. Nitrous Gas. Nitric Oxyde. A gaseous body which may be obtained by pouring upon copper or mercury, in a retort, nitric acid of moderate strength. The nitrous gas comes over in abundance. If kept from the contact of air it is colorless, but the instant it is exposed to contact with this element, it absorbs oxygen

and becomes nitrous or nitric acid. It consists of 47 parts of nitrogen and 53 of oxygen gas by weight, and of equal parts by bulk.

NITROGEN, Protoxide of. Nitrous Oxide. Laughing Gas. A gaseous product obtained by distilling, at a gentle heat, the nitrate of ammonia. It is colorless, increases the bulk of the flame of a taper held to it, and gives it a yellow color; is absorbable to a certain degree by water, and very remarkable in its effects when inhaled, occasioning to most persons extraordinary sensations of pleasure, and producing laughter, increased muscular exertion, &c.

NITRO-MURIATIC ACID. AQUA REGIA. A compound formed by mixing 1 part of hydrochloric to 2 of nitric acid. This compound has the property of dissolving gold and platinum, which neither of the acids will separately, (unless assisted by electricity.) Sometimes the proportions of the acids are reversed from those given above, or otherwise altered to suit particular purposes. An aqua regia may also be made by dissolving nitre in hydrochloric acid.

NITRO-SULPHURIC ACID. A compound of the nitric and sulphuric acids, which may be also readily obtained by dissolving 1 part of nitre in about 10 times its weight of sulphuric acid. This dissolves silver at a temperature below 200. It scarcely acts upon copper, lead, or iron, unless diluted with water. It is therefore useful in separating the silver from old plated articles.

NITROUS ACID. An acid which differs from the nitric by having a fifth part proportionably less oxygen, consisting of 1 atom of nitrogen to 4 of oxygen, by being of an orange color, and producing orange fumes, rendered darker by increase of temperature. It may be obtained by distilling the dry nitrate of lead. Its fumes also arise copiously when diluted nitric acid is poured upon copper.

NITROUS GAS. (See *Nitrogen, Deutoxide of.*)

NITROUS OXYDE. (See *Nitrogen, Protoxide of.*)

NITROUS TURBITH. An old name for the sub-nitrate of mercury.

NITRUM FIXUM. White Flux. (See *Flux.*)

NITRUM FLAMMANS. The former name for nitrate of ammonia.

NITRURETS. Bodies which consist of oxygen, hydrogen, and carbon, joined with 1 atom of nitrogen. Such are many vegetable substances, mushrooms for example.

NOBLE METALS. This absurd name, as Dr. Ure says, has been applied to gold, silver, and platinum.

NOBILI'S GALVANOMETER. Before a galvanometer of a single magnetic needle can obey the influence of the electric current, this latter has to overcome the polar tendency

of the needle. To remedy this the present instrument is adapted. It consists of two magnetic needles, placed with their poles opposite. Thus the tendency of one to turn in a particular direction, owing to terrestrial magnetism, is counteracted by the other, they are therefore free to obey any influence otherwise communicated to them. The needles themselves are connected together by a straw, and suspended by a silk thread A. One needle is within the coil D, conveying the electrical current; the other above the coil, and separated from it by a glass plate C—a hole being pierced in the centre of this plate; and to prevent any agitation of the air from interfering with the instrument, the upper part is inclosed in a glass tube, and the lower part in a glass box B B. As close as possible to the lower needle is a compass card, upon which the deviation of the needle may be ascertained.

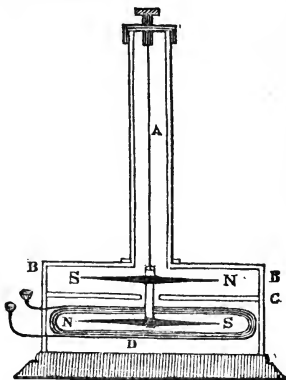

NOCTURNAL. Relating to the night; for example, the nocturnal arch is the course of a heavenly body by night.

NODES. In astronomy, are the opposite points in which the orbit of a planet or of a moon crosses the ecliptic. The *ascending* node, marked by the character \Im , (denominated the dragon's head,) is that where the planet or moon ascends from the south to the north side of the ecliptic; and the *descending* node indicated by the character $\var�$, (the dragon's tail,) is where it passes from the north to the south side. The right line joining these two points is called the line of the nodes.

NODE. In the doctrine of curves is a small



oval figure, made by the intersection of one branch of a curve with another.

NODE. In dialling, denotes a small hole in the gnomon of a dial, which indicates the hour by its light, as the gnomon itself does by its shadow.

NOGGING. Brick-work which is carried up between quarters.

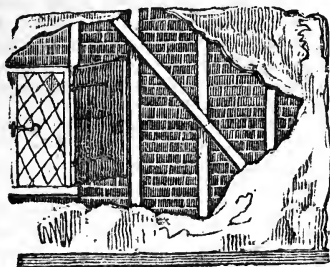

NOGS. Wooden bricks, introduced here and there into walls, for the purpose of fastening internal fittings, window frames, &c.

NONAGESIMAL DEGREE. (See *Mid-Heaven.*)

NONAGON. A figure of nine sides and nine angles. The angle at the centre of a nonagon is 40° , that at the circumference 140° , and its area when the side is 1 is 6.1818242 .

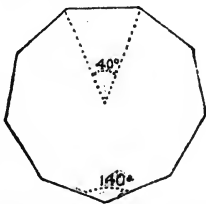

NON-CONDENSING ENGINE. (See *High Pressure Engine.*)

NON-ELASTIC FLUID. Liquids; or such fluids as are not gaseous.

NON-CONDUCTOR. A term applied in reference to electricity, to designate a certain class of bodies which do not convey the electric fluid along their surfaces, or through their pores. Such are the following:—Glass, resin, sulphur, silk, ivory, bone, baked wood, &c. They are also called *electrics*, from the circumstance, that not conveying away the electric fluid communicated to them by friction, or communication with electrified bodies, they by retaining it on their surfaces show electric appearances. (See *Conductor* and *Electric.*)

NONIUS. (See *Vernier.*)

NOOTH'S APPARATUS. (See *Ærated Waters.*)

NORIA. The name of a water engine, common in Spain. It consists of a vertical

wheel, 20 feet in diameter, on the circumference of which are fixed a number of square buckets for the purpose of raising the water. The lower part of the wheel dips into the water of a running stream, and the wheel is turned round by the action of the stream against float boards, with which the wheel is furnished at the back. The buckets dipping into the water become filled, and are by the motion of the wheel carried upwards; when near the top, they meet with the edge of a trough, which turns them over, and conveys away the water thus deposited in it, while the empty buckets return for a fresh supply. This machine is chiefly used for irrigating land.

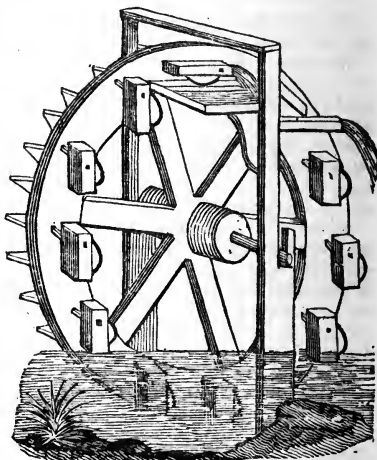

NORMAL. The same as perpendicular.

NORTH. One of the four cardinal points.

NORTHERN LIGHTS. (See *Aurora Borealis.*)

NORTHERN SIGNS OF THE ZODIAC, are those that are on the north side of the equator; they are the six first, Aries, Taurus, Gemini, Cancer, Leo, and Virgo.

NORTHING. In navigation, is the difference of latitude which a ship makes in sailing towards the north.

NORTH POLE. (See *Pole.*)

NORTH STAR. A small star so situated in the heavens as to be very nearly opposite to the north pole of the earth. It appears like a fixture in the heavens, while all the other stars seem to revolve around it, not that they really do so, but only appear to have this motion, in consequence of the rotation of the earth on its axis. The north star is easily found of a clear night, being very nearly in a right line with the two last stars of the great bear, or imagining this constellation to represent a waggon drawn by three horses,

it will be found in a line with the two hind wheels of the waggon, which, from this circumstance, are called the *pointers*.



NOSING. The moulding upon the upper edge of a step.

NOTATION. In arithmetic, is the method of expressing any number or quantity by means of symbols or characters, which symbols are 1, 2, 3, 4, 5, 6, 7, 8, 9, 0. In algebra, the letters of the alphabet, and numerous other marks are employed to indicate the method in which quantities are combined together.

NOZZLE. A projecting part or piece belonging to an engine, particularly to pumps and other water engines. Also that portion of the steam engine in which are placed the valves that open and shut the communication between the cylinder and the boiler and condenser. (See *Cylinder*.)

NUCLEUS. Is used by many astronomers to signify the head or body of a comet, as distinguished from the beard or tail; also for the central parts of the earth and other planets, which some authors suppose firmer, and separated from the other parts as the kernel of a nut is from its shell.

NUMBER. In its most extended signification has a reference to every abstract quantity that can be made the subject of arithmetical computation, but in a more limited sense it signifies only several things of the same kind, and is defined by Euclid to be a multitude of units.

NUMBER, Golden. (See *Golden*.)

NUMBER OF DIRECTION. Some one of the 35 numbers within the Easter limits, or between the earliest and latest days on which it can fall, namely, between March 22nd and April 25th, which is 35 days; and is so called because it serves as a direction for finding Easter of any year, being indeed the number that expresses how many days after the 21st of March Easter-day falls.

NUMERAL ALGEBRA, are those cases in which numerals are employed, in contradistinction to literal, or where letters are used.

NUMERAL FIGURES, are those figures by which all members are expressed in arithmetic, 1, 2, 3, 4, &c.

NUMERAL LETTERS, are seven of the Roman capitals, used by them in expressing numbers; they are I, V, X, L, C, D, M.

NUMERATION. In arithmetic, is the art of reading or estimating the value of any number expressed by the numeral figures or digits, any how combined or repeated, and is therefore the reverse of notation.

NUMERATOR OF A FRACTION is that number which stands above the line, as 7 is the numerator of $\frac{7}{8}$. The whole fraction bears the same proportion to the whole number one, as this numerator bears to the lower figure, or denominator as it is called.

NUMERICAL, or NUMERAL. Relating to number.

NUNCARROW'S STEAM ENGINE. An improvement upon the engine of Savery, in which the steam was condensed in a separate vessel. The following is a detail of its structure; it was, however, never much used, being subsequent and far inferior to the engines of Bolton and Watt. A is the boiler. B the steam pipe, conveying the steam into receiver D, through the valve C. I the condenser. O a reservoir for supplying the boiler with water. J the injection cock. M a pump, by which water is raised from the well to the cistern O by the pipe N. G the reservoir, from which the water raised through the pipe F falls into the buckets of the water wheel, and gives a rotatory motion.

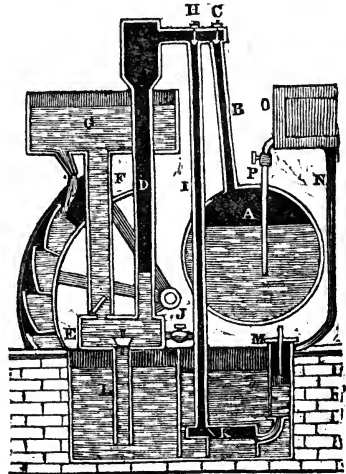

The steam being admitted into D, presses upon the water which it contains, and which is therefore raised through F into G. The valve C being now shut, and H suddenly opened, the steam rushes down I, and meeting with a jet of cold water from J is condensed. A vacuum being by this means made in the

receiver, the water is forced up by the air's pressure, and again fills it, when the valve C is again opened, and H shut; the action therefore goes on as at first. The condensed steam is allowed to fall through the valve into a small box K, whence it is pumped into the boiler again, by the pump M, and through the pipe N, the cistern O, and the cock and pipe P.

NUT OF A SCREW. A piece of iron used in connection with a bolt. It is pierced with a hole, and tapped to fit the screw of the bolt. The nut is screwed upon the end of the bolt, when the latter has been passed through the substances which are to be held together.

NUTATION. In astronomy, a kind of trepidation or tremulous motion of the axis of the earth, whereby its inclination to the plane of the ecliptic is not always the same, but varies backwards and forwards some seconds. The period of these variations is nine years.

NUT GALLS. (See *Galls*.)

NUT OIL. A drying oil; at first of a greenish, afterwards of a yellowish color, much used by the artist in oil colors. It is extracted by pressure from the common hazel and from the walnut.

NUX VOMICA. A poisonous nut, remarkable for containing the vegeto-alkali, strychnia.



A vowel, having several sounds, as are heard in the words, *soon, moan, some, son, not*. It unites with all the other letters of the alphabet, forming of course diphthongs with the other vowels; the combined sound of which, particularly of *ou*, varies very considerably. O by itself is an interjection of surprise, pain, desire, or supplication. As a numeral, when standing alone, it is without value, but placed on the right hand of a number it increases it tenfold: it is then called nought or cypher. On inscriptions it designates *Octavius, Octavus, &c.* O. S. signifies *old style, obt. obedient.*

OAKUM. The substance into which old ropes are reduced, when they are untwisted, loosened, and drawn asunder. It is chiefly used for calking the seams of ships.

OAK. There are numerous varieties of this tree, but that called for distinction sake, "The English species," (*Quercus robur*,) is by far the most valuable, for toughness, resistance of pressure and strain, hardness, and durability. Oak twists much in drying, and in seasoning shrinks about a thirtieth part of its width.

OBJECT. Any thing presented to the mind, either by sensation or imagination; but in optics it is more particularly employed to denote that thing which is to be reflected, magnified, &c.

OBJECT GLASS. In optical instruments, is that which is placed towards the object; the other extreme lens is called the eye glass, being that to which the eye is directed.

OBELISK. A tall, slender, quadrangular pyramid, mostly truncated at the top. Obelisks are a common characteristic of Egyptian architecture; and it is supposed were erected chiefly as commemorative stones, or in some

instances as gnomons, to show the hours by the shadow which they cast upon a dial made around them. The following shows the obelisk, known by the name of Cleopatra's needle.



OBELISK, Electrical. (See *Pyramid*.)

OBLATE. Flattened or compressed.

OBLATE SPHERIOD. A round body of greater width than length, as an orange. The earth is an oblate spheroid.

OBLIQUE. Aslant, indirect, or deviating either from perpendicularity or parallelism.

OBLIQUE ANGLE AND LINE. When one line stands upon another and makes unequal angles therewith, the angles are said to be oblique; the one being greater than a right angle, the other less. Hence a line is only oblique when it relates to another line.

OBLIQUE-ANGLED TRIANGLE. A triangle containing three oblique angles.

OBLIQUE ARCHES, or SKEW ARCHES. Those which cross a road in an oblique direction.

OBLONG. A rectangle; the angles of which

are right angles, but only the opposite sides equal to each other.

OBLONG SPHEROID. A round body of greater length than width, as a lemon.

OBSERVATION. In astronomy and navigation, denotes the measuring, with some instrument adapted for the purpose, the angular distance, altitude, &c., of the sun, moon, or other celestial body.

OBSERVATORY. A building adapted for the observation of the heavenly bodies.

OBSIDIAN. A glassy looking mineral, of a blackish color, found in volcanic countries, and consisting of lava suddenly cooled.

OBTUSE. Any thing blunt or dull, in opposition to what is acute, sharp, or pointed.

OBTUSE ANGLE. (See *Angle*.)

OBVERSE. The side of a coin or medal that bears the head of the chief or sovereign by whom it was cast.

OCCIDENT. OCCIDENTAL. The western quarter of the globe or horizon, or that point of the latter where the sun descends into the lower hemisphere; in contradiction to orient or oriental. Relative to precious stones, as the finest are found in the eastern countries, the term oriental is applied to them as indicative of superior quality, while those of an inferior kind are called occidental, though not necessarily found in the western hemisphere.

OCCULT LINE. In geometry, a line which is necessarily drawn in the construction of a figure, but which is not intended to appear after the figure or plan is finished; such are all the vanishing lines in perspective.

OCCULTATION. The obscuration of a planet or star by the interposition of the moon, or other planet, between it and our eye.

OCEAN. That gigantic body of salt water which encompasses the great divisions of the earth. It is but one continuous mass of water, yet for convenience is divided into the Atlantic, Pacific, Southern or Indian, and the Northern or Arctic Oceans.

OCTAGON. A figure of eight equal sides and eight equal angles.

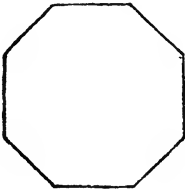

OCHRE. A genus of earths, slightly coherent, and composed of fine, soft, smooth particles, easily miscible with water. These earths are of great value to the artist and the house painter. They are of various colors, yellow, red, and brown. The follow-

ing well-known paints are different varieties of ochre:—Bole, or Armenian bole, terra Sienna, red ochre, redde, ruddle, or red chalk, Venetian red, brown red, yellow ochre, Spanish ochre, stone ochre, &c.

OCTAHEDRON. One of the five regular solids, the surface of which consists of eight equal triangles.

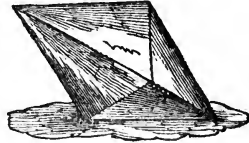

OCTANT. An eighth part of a circle.

OCTOGON. (See *Octagon*.)

OCTOSTYLE. A portico of eight columns.



OCULAR SPECTRA. (See *Accidental Colors*.)

ODD NUMBER. That which cannot be divided into two equal whole numbers; or in other words, that cannot be divided by 2 without leaving a remainder, as 3, 5, 7, 17, &c.

ODDLY ODD NUMBER, is such a number that when divided by 4 leaves a remainder of 3, as 19, 23, &c.

ODOMETER. An instrument for measuring the distance travelled by a carriage. It is attached to the wheel, and shows by means of a dial-plate and index the space passed over. (See *Perambulator*.)

OELIPILE. (See *Aolipile*.)

OENOTHIONIC. A new acid formed out of the sulphuric during the making of sulphuric ether; not however proved to be different from that acid.

OESTED'S EXPERIMENT. Professor Oested trying the effect of holding a balanced magnetic needle near to a wire that a current of galvanism was passing along, found it diverted from its polar direction, and to stand across the wire conveying the current. This was the foundation of electro-magnetism. The following apparatus was made to illustrate the

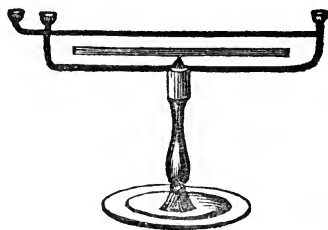

fact :—The upper part is of two wires, united together at one end, but separated from each other by a piece of paper, silk, or other electric at the opposite end, where each wire is terminated by a mercury cup. The stand is of wood. When a current of galvanism is passed from one end to the other, the magnetic needle between the wires will be deflected; if the current pass along the upper wire, the north pole of the magnet will turn one way; if it pass below, it will turn in the contrary direction.

OFF-SET, or SET-OFF. The splay or narrow slanting course of stone or brick, serving to connect two portions of a wall; the uppermost of which recedes from the face of that beneath.

OFF-SETS. In surveying, are those narrow, irregular slips of ground, which are outside of the lines which form the measurement of the principal part of a field or estate. For example, in the following field, the parts A, B, C, D, and E, are off-sets, being outside of the main lines, and they are measured by perpendiculars drawn across them, as is seen in C :—

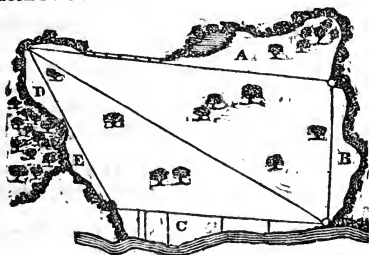

OFF-SET STAFF. A rod or staff, generally 10 links long, and used in field surveying for taking the dimensions of off-sets.

OCEE, or CIMA. A particular kind of moulding. (See *Cima*.)

OGIVES. Those ribs of a Gothic vault that pass from one angle to the opposite, crossing the vault therefore diagonally.

OIL. An unctuous inflammable substance, drawn from various bodies, both animal and vegetable. From the peculiar properties of different oils they are naturally divided into two kinds; the fixed or fat oils, which make and leave a greasy stain upon paper, and the volatile or essential oils, which leave no stain. The former demand a high temperature to raise them to a state of vapor, but the essential oils are volatilized at the temperature of boiling water, or even at a lower one. Both the fixed and essential oils may be obtained from plants, and often from the same plant. For example, almonds yield, by pressure, a bland, limpid oil, similar to salad oil; and by distillation, an oil strongly impregnated with prussic acid, and having the strong smell and

taste so perceptible in the stones of fruit, from the abundance of the acid they contain. The chief oils used for burning and soap making are train or whale oil, sperm oil, and seal oil. Those used to lubricate machinery are mostly olive oil and palm oil. The painter employs linseed oil, poppy oil, nut oil, and sometimes the oil of lavender. The perfumer and confectioner have occasion for rose oil, neroli, the oils of cloves, cinnamon, carraway, peppermint, lavender, and others of the essential oils.

OIL COLORS. Colors mixed or miscible with oil, to which they give a body and a tint; they are either transparent or opaque. The transparent colors are the lakes, Indian yellow, sap green, indigo, Prussian blue, asphaltum, Sienna both burnt and raw, burnt umber, verdigris, &c. The opaque are the ochres, the chromes, vermilion, smalt, most of the copper greens, Naples yellow, most of the blacks, red lead, and numerous others.

OIL GAS. A bi-carburet of hydrogen, obtained by the destructive distillation of oil and fat of various kinds. It has several advantages over coal gas; as the apparatus is less extensive, the gas free from sulphur, and possesses a double illuminating power.

OIL OF BRICK, or PHILOSOPHER'S OIL. When the fixed oils are boiled at a temperature of 600°, and the vapor collected, it is found acrid, sour, and empyreumatic. This was formerly employed in pharmacy, under the name of philosopher's oil; and as it was often obtained by steeping a brick in oil, and submitting it to distillation, it was called *oil of brick*. It is still used by the lapidaries to mix the diamond dust, emery, and other powders with.

OIL OF VITRIOL. The old name for sulphuric acid.

OIL OF WINE. SULPHATIC ETHER. SULPHATE OF HYDRO-CARBON. Names given to a liquid, looking like oil, which is obtained by continuing the distillation of alcohol and sulphuric acid beyond the point at which ether is produced.

OIL PAINTING. The painting in oil colors. **OLLETS.** Peep holes or small loop holes in fortifications, castle walls, &c.

OLEATES. Compounds of oleic acid with the bases.

OLEFIANT GAS. The name originally given to what is now called bi-carburetted hydrogen, or bi-hydro-carbon.

OLEIC ACID, is an acid produced by decomposing by the aid of sulphuric acid the soap made of olive oil.

OLEINE. The thin oily part of fats.

OLEONE, is a liquid obtained by distilling oleic acid with lime.

OLIBANUM. A gum resin, used as an incense.

OMBROMETER. (See *Rain Gauge*.)

OMPHALOPTER. An old name for a convex lens.

ONYX. A semi-pellucid gem, covered with lines or marks like belts or zones, as if made up of a number of coats deposited one upon another.

OOLITE. A species of stone, composed of minute round particles like mustard seeds agglomerated together, apparently with intervening cement.

OPACITY. A state impervious to light; the opposite of transparency.

OPAL. A hard half-transparent stone, which has the power of reflecting different colors. Magnesia constitutes a large portion of its composition.

OPAQUE CUPS, for Microscopes. When the focal distance of a magnifier, either employed singly, or as the object glass of a compound instrument, is too short to admit of an opaque object being illuminated by a light thrown between it and the lens, the magnifier is mounted in the manner shown in the following figure, where the lens is set at such a distance from the surface of the concave polished reflective cup, called an opaque cup, A A, that the object O shall be in its focus and in the focus of the lens at the same time. When thus arranged, the light is reflected from the opaque cup on to the object. If the light be not sufficiently condensed, a double convex lens is interposed between the light and the opaque cup, as at C.

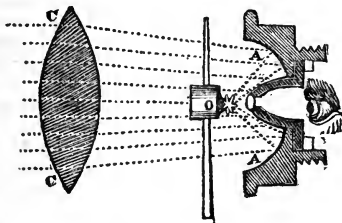

OPENING. (See *Aperture*.)

OPERA GLASS. A short telescope which magnifies only three or four times. It is so called because first used at the Opera House, to obtain a clearer view of the persons and scenes at a distant part of the house. Its glasses are merely a double convex lens at the larger end, and a concave lens at the smaller, or that end to be applied to the eye. Fig. A represents the *bell* opera glass, which has not only an elegant appearance, but on account of its shape, admits of a wide object glass. Fig. B is a *many-drawer* opera glass; the shortness of the several tubes allows this instrument to shut up in a small space. Fig. C shows one adapted to both eyes, therefore called the *binocular* opera glass; and fig. D represents the *diagonal* or *side*

opera glass, which is of a totally different construction from the rest; they all require to be directed to the object to be observed; this is pointed to a different part of the house. This instrument has no object glass, but instead of it a flat mirror occupying the lower part of the body, and inclined at an angle of 45° to the eye-glass, which is double convex, so that the rays are reflected from the mirror to the eye.

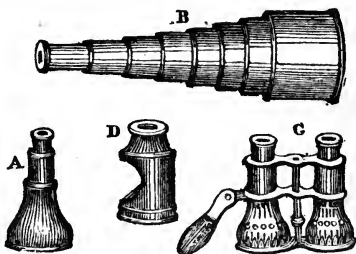

OPIUM. The juice which exudes from the heads of ripe poppies, rendered concrete by exposure to the air and the sun.

OPOBALSAM. The balsam of Peru in a dried state.

OPOPONAX. A gum resin, occasionally used in medicine.

OPPOSITE ANGLES. (See *Angle*.)

OPPOSITION. In astronomy, is that aspect of two heavenly bodies, when they are diametrically opposite to each other.

OPTIC, or OPTICAL. Any thing relating to optics.

OPTIC INEQUALITY. In astronomy, is an apparent irregularity in the motions of the planets and other celestial bodies, being thus called because it does not arise from any irregularity of the bodies themselves, but from the situation of the eye of the observer.

OPTIC PYRAMID, is a pyramid formed by the visual rays proceeding from the eye, and passing through the extremities of any picture; when these rays are continued to terminate in a plane perpendicular to the observer, or else perpendicular to the horizon, as at A, B, C, D.

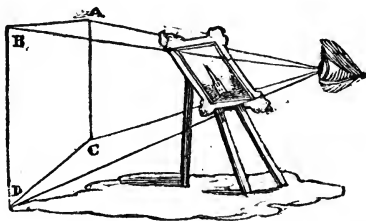

OPTICS. The science of vision; in which sense it includes the explanation of all the

phenomena dependent on light, its transmission, reflection, &c., colors and their combination; and the construction of those instruments which show the properties of light and assist our natural vision, such as spectacles, telescopes, microscopes, mirrors, &c. The properties of light, when reflected, constitutes catoptrics, and when refracted, dioptrics, which sciences are therefore parts of optics.

ORB. A hollow sphere, or shell; in architecture, synonymous with boss and with balloon. (See these terms.)

ORBIT. The path of a planet, comet, or other celestial body. The orbits of all these are elliptical. Those of the comets especially so. (See *Kepler's Laws*.)

ORCHIL. (See *Archil*.)

ORCINE. The name of the coloring principle of the lichen called *Lecidia dealbatus*.

ORDER. In architecture, a particular arrangement and proportion of the parts of a building, and dependent upon the relative form of their columns. The term order is applied only to the Greek and Roman styles, in which are five orders; namely, the Tuscan, Doric, Ionic, Corinthian, and Composite, (which see.) The first and last are Roman; the other three Grecian. Buildings wholly or partially different from the above are often, though improperly, designated by the term order. Thus if an entablature be supported upon caryatides, it is often said to consist of the caryatic order; so also if there be a story to a building above the cornice, and that decorated with pilasters, it is called the attic order. The styles of Gothic, Moorish, Indian, and other buildings, are often improperly called orders. Nothing is truly an order which is not built on acknowledged and established proportions.

ORDER OF A LINE. In the theory of curves is denoted by the dimension of the equation by which the line is defined or expressed. It may be said to be of the first, second, third, &c., order, according as the equation that expresses it is of the first, second, or third degree or dimension.

ORDINARY AND EXTRAORDINARY RAYS. (See *Negative Axis*.)

ORDINATES. In geometry, are lines drawn across a curve, from one side to the other, and perpendicular to the axis, or else from the surface of the curve to the diameter of it.

ORDONNANCE. An old word, to signify the general arrangement and disposition of the parts of a building, painting, procession, &c.

ORGANICAL DESCRIPTION OF CURVES, is the method of describing them on a plane by means of instruments.

ORES are the mineral bodies which contain so much metal as to be worth smelting, or being reduced by fire to the metallic state.

ORIEL. A window projecting beyond the wall, and supported upon brackets.

ORIENT. The east or eastern part of the horizon.

ORIENTAL. The eastern quarter of the world, in contradistinction to occidental.

ORIENTAL GEMS. (See *Occidental*.)

ORNAMENT. Those smaller and more detailed portions of a work of art, which are not essential to it, but added in order to augment its beauty and magnificence. Ornaments are more or less valuable, inasmuch as they are made to blend harmoniously with more important parts, and to assume to themselves the air of essentials.

ORNAMENTS, Iris. (See *Barton*.)

ORPIMENT. A sulphuret of arsenic, used as a pigment. It is found native in many parts of the world, and may be artificially produced by fusing together in crucibles a mixture of sulphur and arsenious acid; or by passing sulphuretted hydrogen through any arsenical solution. That used by the painter is mostly the native orpiment, the best kind of which is found in Persia. It is one of the finest and most favorite yellow colors.

ORRERY, or PLANETARIUM. An instrument for exhibiting the motions of the heavenly bodies. The following shows one of these instruments of a simple form:—It consists of a table, upon the top of which may be delineated the signs of the zodiac, points of the compass, days of the month, and months of the year. In the centre is a strong wire or brass rod, terminated by a brass ball to represent the sun. On this rod are several rings, each bearing a long wire, turned up near the end. These have balls of various sizes at their points, representing the planets of our systems, with such moons as naturally belong to them. The length of the wires and size of the balls cannot be made accordant with the real size of the planets and their orbits, on account of the very great extent of space which would be required. The planets are seen in their natural order of Mercury, Venus, the Earth and moon, Mars, Jupiter and four moons, and Saturn with seven moons. Herschel is for want of space omitted.

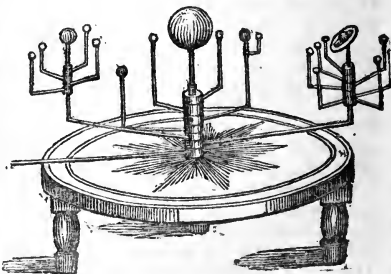

ORRERY, Electrical. A small instrument which beautifully illustrates the motion of the moon around the earth, and both together around the sun. There are three wooden balls of different sizes. The two smaller are connected together by a wire, and are balanced upon a point by a small brass cup near the middle of the wire. The point here alluded to forms part of the wire leading to the ball representing the sun. There is a second cup at the centre of gravity of the whole, where a thick wire supports it, the other end being inserted into the prime conductor of an electrical machine. A small point projects sideways from the moon, and another point, also sideways, but in the contrary direction from the end of the longer wire. When electrified, the escape of the fluid from these points propels the apparatus round its respective centres of motion.

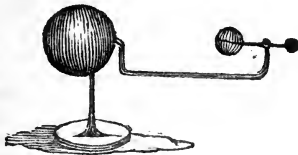

ORSELLE. The same as archil or orchil. **ORTHOGONAL.** The same as rectangular.

ORTHOGRAPHICAL PROJECTION. In architecture, is a correct delineation of any thing, drawn according to its actual measurement, without reference to the rules of perspective. If the outside of a building be thus delineated, it is called an *elevation*; if the interior, it constitutes a *section*.

ORTHOSTYLE. Any straight range of columns; a word but little used.

ORTIVE, or EASTERN AMPLITUDE. In astronomy, is an arc of the horizon between the place where a star rises and the eastern point of the horizon.

ORYCTNOGOSY. Synonymous with mineralogy.

OSCILLATION. Swinging. The term is particularly applied to the motion of a pendulum.

OSCILLATION, Axis of. A right line passing through the point of suspension, parallel to the horizon.

OSCILLATION, Centre of. A pendulum when oscillating has one point in which its whole moving force is concentrated, and at which, if it meet with resistance, it will instantly stop without vibration or strain of the other parts; that point is called the centre of oscillation.

OSCUATION. In the theory of curves denotes the contact between any curve and its osculating circle; or that circle which has the same curvature as the curve at the given point of osculation. Let A C, fig. 1, be

the evolute of the curve A E F, and the tangent C E the radius of curvature at the point E. With this distance, C E as a radius, and the centre C, describe the circle B E G. This circle is said to osculate or kiss the curve A E F, at the point E, which point E is called the point of osculation; C E the osculatory radius, or radius of curvature; the circle, B E G, the osculatory circle; and the evolute, A C, the locus of all the centres of the osculatory circles. A point of osculation is also used to denote the concurrence of two branches of a curve that touch each other, as in fig. 2; supposing the two branches of the curve are extended beyond the point of osculation, otherwise it becomes a cusp.

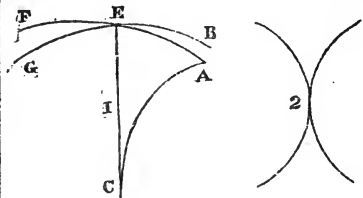

OSMAZOME. If cold water, which has been digested for a few hours on raw muscular fibre, with occasional pressure, be evaporated, filtered, and then treated with pure alcohol, a peculiar animal principle will be dissolved to the exclusion of the salts. By dissipating the alcohol by a gentle heat, the osmazome is obtained. It has a brownish yellow color, and the taste and smell of soup.

OSMIC ACID. This union of oxygen with osmium, though called an acid by Berzelius, has no acid re-action, yet combines with alkalis. It is, according to Brande, the peroxyde of osmium. It is volatile, has a very peculiar odour, is acrid, poisonous, and stains the skin.

OSMIO-CHLORIDES. Compounds of osmium with the hydro-chloric acid.

OSMIUM. A metal discovered by M. Tennant in 1803, among grains of native platinum. It has not hitherto been applied to any use in the arts.

OSTEOCOLLA. The glue obtained from bones. The white or satin size used upon paper hangings, previous to their being varnished, is of this manufacture. Its adhesive properties are very inferior to hide glue.

OTOCUSTIC. A name formerly applied to any instrument used to assist the hearing, as the ear trumpet.

OUSE. Preparation of bark, used by tanners.

OUTLINE. The contour or boundary of any thing. Drawing or engraving in outline is

depicting only the contour of an object, without any shading within it.

OUT TO OUT. An expression used by builders to signify a measurement which is taken from the outermost bounds of an object.

OVAL. An oblong, curvilinear figure, having two unequal diameters, and bounded by a curve line returning into itself. Under this general definition of an oval is included the ellipse, which is a regular oval. All other figures which resemble an ellipse, though without possessing its properties, are classed under the same general denomination; as the egg-shaped and pear-shaped body. The three following figures, A, B, C, are therefore ovals, but only the first of them is an ellipse.

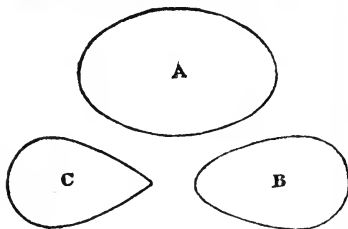

OVAL CHUCK. An appendage to a lathe, of such a nature that the work attached to it and cut by the tool in the usual manner becomes of an oval form. A in the following cut shows the front of a mandril of an ordinary lathe, fitted up with an oval chuck. The lateral projections are for the support of the director B B. This is a piece of cast iron, having arms perforated with openings in the direction of its diameter, so as to allow it to be fastened in the required position, by means of screws, on the face of the mandril or puppet. From the surface of the circular part projects a ring or neck C, as shown underneath. The chuck or sliding part consists of three circular plates

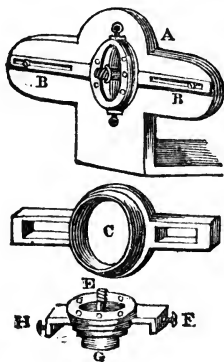

of considerable strength; to the first is attached the piece G, (lower figure,) which has an internal screw that fits into the screw of the mandril. The middle plate consists of two semicircular pieces, between which, and upon the surface of the first plate, the piece F is made to slide. To this slider is firmly attached the nose E, to which is affixed the article to be turned. The extremities F H are bent so as to fit exactly upon the projection C; their smooth and uniform motion being still farther secured by means of two screws. The action will be better understood by referring to *Trammel*.

OVALBUMEN. Albumen obtained from the white of eggs, so called to distinguish it from ser-albumen, or that obtained from the serum of the blood.

OVEN. An inclosed kiln, employed for baking and drying various substances.

OVERSHOT WHEEL. A wheel which is turned by water flowing on the top of it.

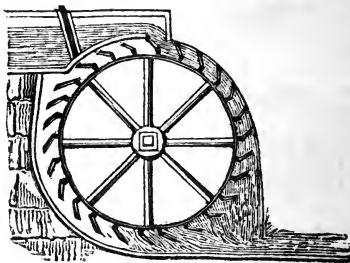

OVOLO, or ECHINUS. A quarter round moulding.

OVUM. An egg; part of the egg and tongue ornament. (See *Egg and Tongue*.)

OXALATES. Salts compounded of oxalic acid and earths, alkalies or metals.

OXALIC ACID. An acid first extracted from the *oxalis acetocella*, or wood-sorrel; hence its name. It is now made entirely from sugar, by digesting it in about four times its weight of strong nitric acid. It is often sold under the name of the salt of sorrel, and as such is used to take out stains from furniture, dresses, &c. It crystallizes in needle-shaped crystals, which are soluble in water and in alcohol. Ure says that it differs from all the other acid products of the vegetable kingdom in containing no hydrogen. It is used chiefly as a bleaching material in the calico printing, and to clean boot tops.

OXALOVINIC ACID. An acid appearing to consist of two atoms of oxalic acid, and one atom of etherine.

OXAMIDE, OXALAMIDE. When the oxalate of ammonia is distilled, it becomes opaque from loss of water, fuses, boils, decomposes, and volatilizes, leaving a little

carbon behind; the liquid which passes over contains a flocculent substance, which also lines the neck of the retort; this has received the name of oxamide or oxalamide.

Ox Gall. (See *Gall.*)

OXIDATION. The process of converting metals or other substances into oxydes, by combining with them a certain proportion of oxygen.

OXIDES. (See *Oxydes.*)

OXIODIC ACID. A union of iodine and oxygen, in the proportion of one atom of the former to seven of the latter.

OXISELS. Salts of which oxygen forms a part, so called to distinguish them from the halosels, or those containing no oxygen, such as the chlorides, iodides, and bromides.

OXYDES, or OXIDES, are neutral compounds, containing oxygen, united to some base. (See *Oxygen.*) According to the quantity of oxygen that enters into the combination, it is called the protoxyde, sesquioxide, deutoxyde, tritoxye, or peroxyde.

OXYACIDS. Those acids which derive their acid properties from the presence of oxygen.

OXYGEN. A gaseous element, void of taste, smell, and color; heavier than atmospheric air, and constituting about a fifth part of it; also two parts of oxygen united to two of hydrogen forms water. It is the constituent necessary for the support of animal and vegetable life, as well as combustion. There is no body in nature with which it will not unite, forming oxydes, which according to their properties are called simply *oxydes*, if neutral; *alkalies*, if showing alkaline properties; *earths*, if earthy; and *acids*, if the oxygen so preponderates over the base as to make the compound to assume the characteristics of an acid. It may be obtained in many ways—by the decomposition of water by galvanism; by putting green leaves in a bell glass, exposed to the rays of the sun; by means of a glass retort, in which is placed some of the chlorate of potass—heat being applied, oxygen is given off. The most usual way, however, is with an iron retort; the peroxyde, or as it is commonly called, the black oxyde of manganese, is put in it, the retort fitted with a tube which will convey the gas to a receiver or gasometer, then put into a strong fire, when the gas will distil over.

OXYGENATED MURIATIC, or OXY-MURIATIC ACID. The name formerly given to chlorine, under the supposition that oxygen formed its acidifying principle, as well as that of muriatic acid.

OXYGENATION. This word is often used instead of oxydation, and frequently confounded with it; but it differs in being of more general import, as every union with oxygen, whatever the product may be, is an

oxygenation, but oxydation takes place only when an oxyde is formed.

OXYGEN. OXYGONAL. Acute angled.

OXY-HYDROGEN BLOW-PIPE. A blow-pipe, the lamp or heat of which is urged by a stream of the mixed gases, oxygen and hydrogen. (See *Clarke and Gurney.*)

OXY-HYDROGEN MICROSCOPE. This is a valuable instrument of public exhibition, so called because the light is formed by the action of hydrogen, thrown in an ignited state upon a cylinder of lime; its flame being at the same time urged by a jet of oxygen, or rather the two gases are previously mixed together, and thrown upon the lime. The instrument in other respects nearly resembles the magic lantern. Fig. 1 shows the whole complete. A and B are two cocks, connected with the bladders holding the gases, one of which is twice the size of the other—twice the quantity of hydrogen being necessary. These cocks are connected with the blow-pipe chamber C; from the top of which a jet conveys them against a small cylinder of lime D, producing an intense white light, which is reflected by the reflector E on to the lenses in the tube of the instrument. Fig. 2 shows the best method of arranging the glasses; A is here the reflector. B the light. C a double convex lens, to condense the light upon the object. D the slider of objects. E two plano-convex lenses, forming an achromatic eye piece, through which the rays of light pass, and depict the object of an immense size upon a screen prepared to receive it, in the same manner as in the exhibition of the magic lantern.

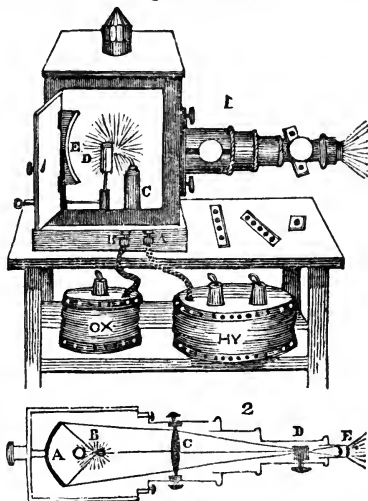

OXY-PRUSSIC ACID. Chloro-prussic or chloro-cyanic acid.



A consonant, pronounced by the action of the lips, differing in a very slight degree in sound from B, with which it is frequently confounded, particularly by the inhabitants

of some parts of Wales, of Lower Saxony, &c. It combines with several other consonants, and is silent before *n*, *s*, and *t*, as in *pneumatic*, *psalm*, *receipt*, &c. P standing alone signifies *Publius*, *Publicola*, *post*, *piano*, *parliament*, *professor*, &c.

PACKING. The fastening of any thing up tightly; also the hemp or other material put round or between the various parts of a pump or steam engine piston to keep it tight and prevent the steam or water from oozing through.

PADDING. That process in the art of dyeing and calico printing which consists of impregnating the article with a mordant, previous to imbuing it with the coloring material.

PADDLE. A small sluice similar to those by which locks are filled and emptied.

PADDLE. A flat piece of wood or metal used to propel a boat by its counter-action on the water.

PADDLE HOLES. The crooked arches through which the water passes from the upper pond of a canal into the lock to fill it; or through which it is let out into the lower pond, on the entrance and exit of vessels.

PADDLE WHEELS. The wheels employed in the propulsion of steam boats, supporting paddles or floats fixed at equal distances around the rim; they are placed one upon each side of the vessel, and are secured to a strong shaft passing across it, which is turned round by the engines, each engine working a crank fixed to it.

PAGODA, or PAGOD. A name which has been given to all the temples of the Indians, of whatever shape or size, or to whatever idol or deity they may be dedicated. The Indian pagodas are mostly square; those of China are lofty towers, which sometimes rise to the height of many stories, and are exceedingly magnificent.

PAINTS. Various vegetable and mineral substances possessing a strong color, and therefore used with water, oil, or other medium with which they are blended, to pass over the surface of wood, metal, stone, canvas, &c., to communicate to that surface the same color as the paint or pigment, or the combination of them which is employed. From the metallic oxydes are derived the greater part of our pigments.

PAINTING. The art of covering over a surface, by means of artificial colors. According

to the purpose and the material employed so there are different styles of painting; of which the following are the principal:—Oil painting, fresco, miniature, enamel, encaustic, distemper, water color and doric, on glass, &c., and which styles are sub-divided, according to the respective subjects chosen, into historical, landscape marine, figure, flower, architectural, still life, portrait, and many others.

PAINTER'S CREAM. Painters, who have long intervals between their periods of labor, are accustomed to cover the parts they have painted with a preparation which preserves the freshness of the colors, and which they can remove when they resume their work. This preparation is as follows:—Dissolve half an ounce of mastic in 3 ounces of nut oil, over a gentle fire; put it when melted into a marble mortar, and stir into it $\frac{1}{2}$ of an ounce of sugar of lead, adding water in small quantities till it assumes the appearance of cream.

PAINTER'S VARNISH, is but another name for boiled linseed or drying oil. It is made by simmering over a slow fire for four or five hours, in a pipkin, a mixture of a quart of linseed oil, with about half an ounce of powdered litharge, and a quarter of an ounce of white vitriol.

PALE. A little stake or piece of wood, used in making inclosures, separations, &c.

PALES. (See *Piles*.)

PALETTE. Among artists, is a little ivory or wooden tablet, very thin and smooth, on and round which are placed the several colors required by the artist, that they may be ready for the pencil.

PALETTE KNIFE. A long knife, with a very thin well-tempered blade, used by artists for mixing colors, or for rubbing down such as have been previously ground on the palette.

PALING. In agriculture, a kind of fence-work for trees, planted in exposed situations. It consists of three small posts driven into the ground, at a foot and a half distance, with short bars nailed across them near the top.

PALISADES. A high and strong paling used in fortification, to defend open and exposed places; they are driven strongly into the ground, are well secured together, and are pointed towards the enemy.

PALL. A detent, or click; that is, a small piece of metal that falls between the teeth of a ratchet wheel, to prevent a load which has been raised from descending when the operative power is removed. It is the pall falling into the teeth of a ratchet wheel which is heard when a clock is wound up, or when a capstan is turned to heave up the anchor.

PALLADIUM. The name given to a metal discovered in 1803, by Sir H. Davy, associated with platinum, among the grains

of which he supposed the ore to exist, or an alloy of it, with iridium and osmium, scarcely distinguishable from the crude platinum, though it is harder and heavier. The pure metal also very nearly resembles platinum, and takes a high polish. It is ductile, very malleable, and when reduced into thin plates, flexible, but not very elastic. It is harder and heavier than iron; its specific gravity is from 10.9 to 11.8.

PALLAS. One of the new planets discovered by M. Olbers. It is situated between the orbits of Mars and Jupiter. It is distinguished from all the other planets by the great inclination of its orbit, being about 35° . Its diameter is, according to Herschel, only 80 miles. Its mean distance from the earth is 266 millions of miles.

PALLET. That part of a clock or watch escapement on which the wheel strikes. (See *Escapement*.)

PALMER'S ELECTRICAL MACHINE. This instrument is a great improvement upon the common electrical machine. The difference between them is, that this is furnished with a double cushion and a double prime conductor, whereby the power is increased, though not by any means in a double ratio. A is a thick brass tube, having a ball at the top, and two arms projecting sideways, furnished with points, as C C. The tube A supports one end of the cylinder, and is itself supported upon a solid glass pillar D. B B are glass pillars which support the cushions and flaps. (See *Cylinder Machine*.)

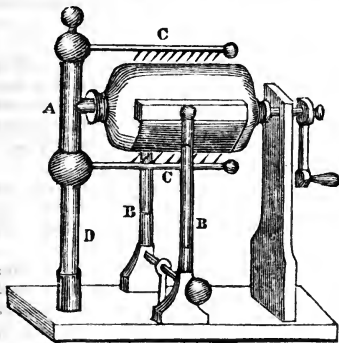

PALMER'S GAS LAMP FOR HEATING TUBES. The figure below will sufficiently explain this useful instrument. It is screwed on to a gas-pipe, in the manner of an

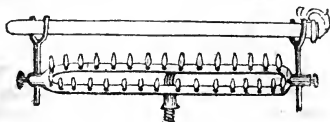

ordinary burner, the tube resting on two supports at the end.

PALMER'S PNEUMATIC FILTERER. A very ingenious application of a well-known fact in pneumatics, that the atmosphere presses upon a surface with a force equal to 15 lbs. on the square inch, when a vacuum is produced beneath it. This filtering machine is formed of two vessels, fitting air-tightly upon each other. The upper vessel contains the substance to be filtered: it is open at top, and with a perforated bottom, like an ordinary coffee filterer; the lower vessel, which is to receive the liquid when filtered, is completely air tight, and furnished with an exhausting syringe, by which air is drawn from within it. As soon as this is commenced, the atmosphere presses upon the surface of the liquid in the upper vessel, which forces it into the receiver beneath, whence it may be drawn off. The filterer is made of numerous forms; the following is one of the most ornamental:—



PALMER'S ROTATING MAGNET. A pretty electro-magnetic apparatus, of simple formation. It consists of a bar of common iron, (an iron hoop, 6 or 8 inches long, will do.) It has covered wire coiled round it, as represented; the ends dipping into a cup of mercury. The cup has a little division across it of wood, so that when the wires are one on each side of the partition, there is no metallic communication between them; the wires proceed under the stand, one from each side of this cup to two other distinct cups near the end. The iron bar is nicely poised upon a centre, so that it moves with little friction. When the two poles of an electro-magnetic battery are placed, one in each cup, the iron, which has now become a magnet, will rapidly rotate on its axis, provided one end of it be placed between the poles of another magnet.

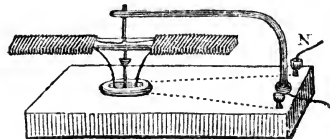

PALM OIL. A concrete oil, obtained from different species of the palm tree, particularly the *Elæinus Guineensis*, a tree of the Western Coast of Africa. It is of a deep yellow color, and used in the manufacture of soap; occasionally candles; and still more especially for lubricating the axle-trees and other rubbing parts of railway carriages, &c.

PALMIC ACID. When palmine is saponified, and the alkali precipitated by an acid, palmitic acid is separated.

PALMINE. A substance obtained by M. Boudet from castor oil, by solidifying it with hypo-nitrous acid.

PANE. A distinct light in a window.

PANE, Electrical. (See *Magic Picture*.)

PANEL. A compartment in a wall, ceiling, &c., surrounded either by mouldings, or by parts called styles, which are not usually flush with the panels. Panels used to be once made highly ornamental, not merely in form, but by means of painting and gilding.



PANEL. In masonry, one of the faces of a hewn stone.

PANORAMA. A picture exhibiting a succession of objects upon a spherical or cylindrical surface, the rays of light being supposed to pass from all points of external objects, through the surface to the eye in the centre of the sphere, or axis of the cylinder, as near as possible to which the spectator who views the picture is to be situated.

PANTAGRAPH. (See *Pentagraph*.)

PANTHEON. In architecture, a temple or building of a circular form, dedicated to all the gods. The most celebrated Pantheon is that of Rome.

PANTOCHEMETER. A name given by Mr. Essex to an instrument constructed as follows:—A sun dial is affixed to a magnetic needle, suspended in the usual way, in such a manner as to allow for the variation; it adjusts itself in every position of the instrument. The divisions of the hours and their fractions, and which are carried on to an additional exterior circle, correspondently divided; and a fixed circle around the dial, on which are inscribed the names of a number of places. By this arrangement the gnomon gives the

time at the place of observation, and also for any other place inscribed upon it.

PAPER. The leaves or sheets fabricated of fibrous materials, and adapted to write or draw upon, as well as for numerous other purposes. The chief sorts are writing and drawing papers, printing papers, packing papers, and numerous others. *Writing and drawing papers* are separated into *wove*, or such as are perfectly smooth on the surface, and *laid*, or those papers which retain on them the marks of the wire frames upon which the pulp is laid; called water-marks. Papers of this class varying in size, from demy, a sheet of which is about 19½ inches by 15½, up to antiquarian, the largest size made, are called drawing papers. From demy downwards to the smallest, called pot; they are writing papers. *Printing papers* are rather softer and lighter, and vary much in size. That used for the best impressions of copper-plates, is called *plate paper*, and is soft and bibulous. *India paper* is made from the bamboo; it comes from China, and is used as a superior article for the same purpose as plate paper. Besides the above there are *cartridge paper*, *blue paper*, *brown paper*, *hand*, or *white-brown paper*, *sugar paper*, *blotting paper*, *tissue paper*, a soft kind of which is called *copying paper*; *Manchester paper*, which is a large, coarse, brown kind; *sheathing paper*, for the use of ship-builders; and *tip paper*, for hatters; *colored papers*; rough *crayon paper*, for artists; besides a variety of papers differently ornamented after their manufacture, as *embossed*, *marbled*, *colored*, *silvered*, &c.

PAPER, Sand, Emery, Glass, &c. Sheets of paper washed over with glue, and then dusted with one or other of the above materials, previously ground or sifted to the requisite degree of fineness. Such papers are used for polishing and smoothing substances by artisans and others.

PAPER, Tracing, is of two kinds; one perfectly transparent, made by rubbing common tissue paper over with poppy oil, Canada balsam or varnish. The other, colored, and made by rubbing upon thin paper a mixture of black-lead and water, lamp black and soap, or sometimes red chalk. The first kind being laid over a drawing, the drawing appears through it, and consequently can be traced. The second being laid between a drawing and a sheet of white paper, (the colored side being on the paper,) when a hard point is passed over the lines of the drawing, a part of the color comes off and leaves corresponding lines on the white paper beneath.

PAPER-HANGINGS. Long sheets of paper, stained and printed in various devices, for the purpose of lining the walls of apartments, to give them an ornamental appearance.

PAPIER MACHEE. A name given by the French to an artificial substance, applied to many useful and elegant purposes. It is made of the waste cuttings of paper, boiled in water, and beaten to a pulp in a mortar. It is afterwards mixed with size, to give tenacity to the paste, and when brought to the proper consistency it is pressed in moulds of an infinite variety of forms, and thus made into tea trays, snuffers, &c., which are afterwards coated with pigments, varnished, and ornamented.

PAPIN'S DIGESTER. An iron pot or kettle, which has a cover that fits and screws on steam tight, and is furnished with a safety valve, as represented below. The use of the instrument is that bodies may be subjected to a greater degree of heat than that of boiling water, whereby their digestion and solution is materially-assisted. For example, bones will dissolve in water by the assistance of a Papin's digester, and yield a strong nutritious soup, almost equal to that from meat.

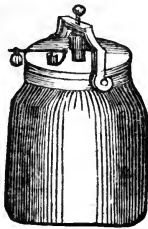

PAPIN'S STEAM ENGINE. This engine, which is one of the earliest, having been constructed in 1707, was intended only to raise water. It was never extensively patronized, but yet it had some important peculiarities, particularly the introduction of the *safety valve*, also the elasticity of the air in the receiver producing a constant stream of water.

A is the boiler, set in brick-work, communicating by the steam pipe B with the pump cylinder. This cylinder terminates in the crooked pipe E S, leading to the straight pipe X, which enters the air-tight cylinder R R, rising to within a short distance of its top. F is the safety valve. Within the cylinder I is a float or piston N. When a sufficiency of steam is generated in A, the cock C is turned, allowing it to pass into I, where it presses upon the piston N, forcing the water which is beneath it through the pipe X into R R; this condenses the air in R R. The cock P is then opened, and the water issues with great velocity on to the float boards of the water wheel, turning it round, and consequently working pumps or other machinery attached to it. When the piston N is driven down, the steam is shut off at C, and the cock D is opened. When this is the case

the steam in I escapes; at the same moment M is opened, which admits a fresh supply of water into I, the valve O at the same time closing, and preventing the return of the water from R. When the piston has risen to the proper height, the steam is again admitted, and the action goes on as at first. In the first form of the engine a heater H was introduced at G, and rested upon the top of the piston; intended to prevent the too sudden condensation of the steam by contact with the otherwise cold piston.

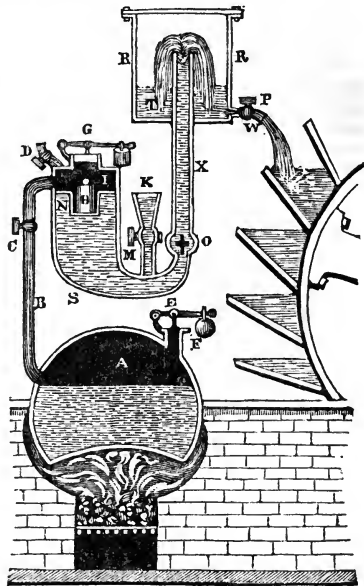

PARABOLA. PARABOLIC. A curved line made by the common intersection of a conic surface and a plane which cuts it, supposing this plane to be cut parallel to the side of the cone. The curved line which bounds it is called the parabolic curve. (See *Conic Sections*.)

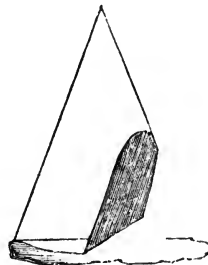

PARABOLOID, or PARABOLIC CONOID, is a solid generated by the rotation of a parabola about its axis, which remains fixed.

PARACENTRIC MOTION, is the motion of a planet towards the centre of attraction, or the sun. The orbits of the planets being elliptical, they are sometimes nearer and sometimes more remote from the sun, and the difference in this distance is what is called the paracentric motion.

PARACHUTE. An instrument shaped like the common umbrella, but infinitely larger, invented by M. Garnerin, in order that he might descend safely from his balloon in case of any accident happening to it. When ascending, the parachute hung from the balloon in a collapsed state, the car being attached to it. When M. Garnerin descended from his balloon, which he did safely, in 1802, at London, the parachute upon being cut away, vibrated considerably for the first minute, but afterwards came steadily and softly to the ground. The following is the representation of M. Garnerin's parachute :—



PARACYANOGEN. When cyanuret of mercury is decomposed by heat, a brown solid matter remains, having the same composition as gaseous cyanogen; hence denominated as above.

PARADIGMMATICE. The art of working and forming figures in plaster; a term now obsolete.

PARADOX. In philosophy, a seeming contradiction and apparently absurd, yet nevertheless accordant with fact. To say that a person may move 1000 miles an hour and yet be asleep appears absurd; yet, the earth in its rotation on the axis carries him along faster than this.

PARADOX, Hydrostatic. (See *Hydrostatic*.)

PARAFFINE. A solid bi-carburet of hydrogen. It is white, void of taste and smell, feels soft between the fingers, and burns with a clear white flame, without smoke or residuum. It is decomposed neither by chlorine, strong acids, nor alkalis. It is obtained by the distillation of beech tar.

PARAGRAPHINE. An instrument, the object of which is to avert hailstones in the same manner as electric conductors avert the danger of lightning.

PARALLACTIC ANGLE, is the angle subtended by two lines drawn from the centre of a planet; the one to the centre of the earth, and the other to some point on its surface.

PARALLAX. An arc of the heavens intercepted between the true and apparent place of any of the heavenly bodies; that is, between its place as viewed from the earth, and from any point on its surface. Thus, let O be the centre of the earth. A B C three different planets, or three different positions of the same planet. Then its true places in these positions, as seen from the centre of the earth, and as referred to the heavens, will be A B C; but their apparent places will be A E F, if seen from the point D. That seen in the same straight line with O D will have no parallax; but in the other instances the arc E B, F C will be the measure of the parallaxes of the parallaxic angles E H B, F I C, and also of D I O and D H O, to which being opposite angles they are equal.

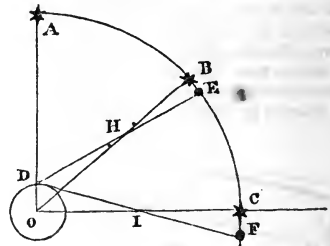

Parallax receives particular denominations, according to the circle upon which it is computed. The above is called the *parallax of altitude*. *Horizontal parallax* is that which it obtains when the star is on the horizon; it is greater than at any other time, as is obvious from the above figure. *Parallax of right ascension and descension* is an arc of the equinoctial, by which the parallax of altitude increases the ascension and decreases the descension. *Parallax of declination* is when the declination of a star is increased or diminished by the same cause; so also a parallax of latitude increases or lessens the latitude of a star. The *mentrual parallax of the sun* is an angle formed by two straight lines; one drawn from the earth to the sun, and another drawn from the sun to the moon, at either of their quadratures. *Parallax of the annual orbit of the earth* is the angle at any planet, subtended by the distance between the earth and sun. *Parallax of the planets, the moon, and the fixed stars,* the angle made at any

planet, &c., by two lines drawn from the centre of that planet, &c.; one to the centre of the earth, the other to its surface—a radius of the earth being the distance of the lines at their divergent ends. It is from the parallax of the planets that their distances from the sun are computed.

PARALLEL. A term applied in geometry to lines, figures, and bodies which are every where equally distant from each other, and which, though infinitely produced, would never meet

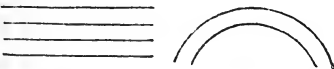

PARALLELS OF LATITUDE, DECLINATION, &c. (See these terms.)

PARALLELISM. The quality of being parallel.

PARALLELISM OF THE EARTH'S AXIS, is used to denote that invariable position of the terrestrial axis, by which it always points to the same point in the heavens, abstracting for the trifling effect of nutation, &c.

PARALLEL MOTION. A particular part of the steam engine, the object of which is to preserve the piston rod and pump rod always perpendicular, or parallel to the sides of the cylinder, that there may be less wear, and consequently less friction and greater equality of motion in these important parts.

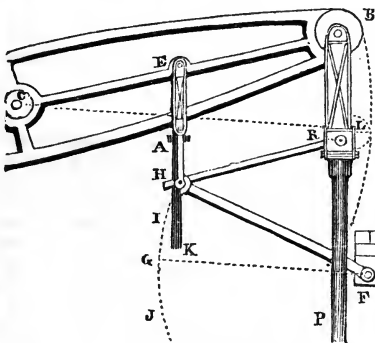

Let R be the head of the piston rod P R. B the end of the beam. B describes the segment of a circle, and R moves vertically up and down. These motions are adjusted so as to harmonize with each other by the following contrivance. Let a fixed point F be taken, as near as possible to the line in which the piston rod moves. From the points B and E of the beam let inflexible bars R and E H hang down, moving freely on pivots at B and E. Let the extremities

H and R of these bars be connected by a transverse bar R H, and let another rod pass from H to F, all having free motion on pivots at both extremities. Let the head of the piston rod be attached to the pivot at R. Then it will have motion without any considerable strain, and remain quite vertical throughout its course, as although the end of the beam projects the piston rod outwards, as is seen in the arc L, yet the rod F H projects it equally in the contrary direction, according to the arc I G J; and as those side motions counteract each other, the parallelism of the piston rod is preserved.

PARALLEL SAILING. In navigation, sailing on a parallel of latitude, that is, moving exactly east or west.

PARALLEL SPHERE. That position of the artificial globe in which the equator coincides with the horizon, and the poles with the zenith and nadir. A spectator placed at the pole would be situated on a parallel sphere. The stars to him would appear to pass round the earth in circles, and not rise or set; and the sun would rise and set only once in each year, remaining for six months above the horizon, and as many below it.

PARALLELOGRAM. A figure or substance, the opposite ends of which are parallel to each other. It may be a square, a rectangle, a rhombus, or a rhomboid. Also a name sometimes given to the pentagram, (which see.)



PARALLELOGRAM OF FORCES, is a term used to denote the composition of forces, or the finding a single force that shall be equivalent to two or more given forces when acting in given directions. Thus referring to the following diagram; if a body A receive

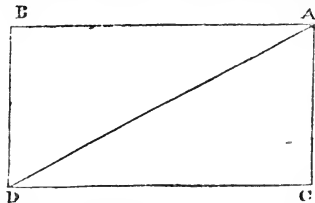

such a blow as will drive it from A to B in a given time, and at the same moment receives another blow which would drive it to C in the same time, it would, if thus doubly acted upon, obey neither of these forces, nor yet proceed along either the line A B, or the line A C, but take a third direction, and pass along a line between them; and if lines be drawn from the point

D, where the ball actually stops, to the points B and C, they would form a parallelogram figure, which is called the parallelogram of forces. When, therefore, any thing is acted upon simultaneously by two forces, it will obey neither, but proceed along the diagonal of the parallelogram, the adjacent sides of which are in proportion to the relative forces impressed upon the object.

PARALLELOPIPED, or PARALLELOPIPEDON. One of the regular bodies or solids comprehended under six parallelograms, the opposite sides of which are equal and parallel.

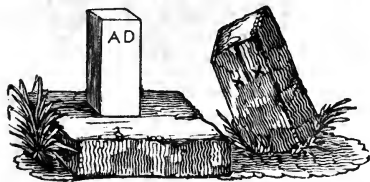

PARALLEL RULER. An instrument for drawing parallel or straight lines. Parallel rulers are of different construction. Fig. A shows the ordinary form, as usual in a case of mathematical instruments. The two parallel bars are united together by long joints. Holding one bar steady with the hand, the other may be moved up and down, as required. The other form, represented by B, is far superior. It consists of a single piece of wood, having near the centre of it a round or a grooved ruler turning in two sockets, one at each end, and somewhat increased in size towards the end by two milled-headed or micrometer nuts, so that being rolled down a paper, the ruler at the same time remains perfectly steady, and continues parallel.

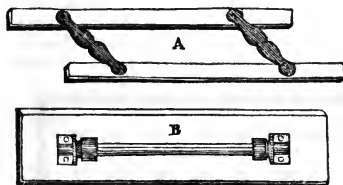

PARAMALÆATES. Neutral combinations of the paramalæic acid.

PARAMALÆIC ACID, is produced by the continuous action of a moderate heat upon the malæic acid, or by boiling it in a long tube, so that the evolved water constantly falls back upon the acid.

PARAMETER. A certain and constant right line in each of the three conic sections; it is always a third proportional to the trans-

verse and conjugate axes of the ellipse and hyperbola; and what is the same thing, a third proportional to any absciss and its corresponding ordinate in the parabola.

PARANAPHTHALINE. A hydro-carbon; closely resembling naphthaline in all its properties, but less volatile, and therefore in the distillation of coal tar, whence it is produced, it is among the latter of its products. According to Reichenbach it is a mixture of naphthaline and paraffine.

PARAPET. A dwarf wall or railing, intended as an inclosure, as the parapet of a house incloses the roof; of a terrace or bridge, it incloses those who pass along it: often synonymous with balustrade.

PARASELENA. A mock moon; or the same phenomenon applied to the moon, as parhelia is in reference to the sun, and arising from a similar cause. (See *Parhelia*.)

PARA-TARTARIC ACID. (See *Racemic Acid*.)

PARCHMENT. The skin of sheep, calves, or goats, prepared after such a manner as to render it proper for writing or drawing upon. The finer kinds are called *vellum*.

PARGET. A name given by workmen to the various kinds of gypsum, which being calcined and ground, forms plaster of Paris; used by plasterers, &c. in pargetting, and other ornamental work.

PARGETTING, or PERGETTING. A surface of plaster made ornamental by slight waves, mouldings, impressions, &c. The ceilings of houses built in the time of Elizabeth contain mostly fine specimens. Common plastering is also sometimes called pargetting, though improperly so.

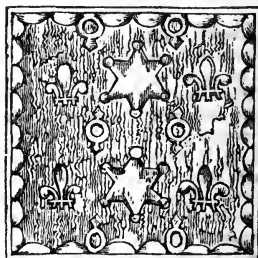

PARHELION, or PARHELIUM, denotes a mock sun or meteor, appearing as a very bright light near the sun, being formed by the reflection of his beams in a cloud properly prepared to receive it.

PARQUETRY. (See *Marquetry*.)

PARTICLE. The minute portion of any thing, whether single atoms or several united together; more generally designating the latter.

PARTING. In metallurgy, an operation by which gold and silver are separated from each other; or in other words, the refining of the precious metals.

PARTY WALLS. In building, partitions of brick made between separate buildings, to prevent the spread of fire, &c.

PASTE. A kind of glass, of great specific gravity, made to imitate gems. Paste gems look brightest to the wearer; real ones to the observer. The following receipt is recommended as proper for the foundation of them all, requiring only coloring with the requisite ingredient. Purified white sand, 100 parts; red oxide of lead, 200 parts; calcined potass and nitre, each 20 to 25 parts. It must be kept fused for two or three days; this will imitate the diamond. For the emerald, add to 160 parts of the above glass, 4 parts of oxide of copper, obtained by calcination. For sapphires, add to 100 parts of the glass, 1 part of zaffre, and $\frac{1}{10}$ of a part of oxide of manganese. For the amethyst, take 25 pounds of the glass; $\frac{1}{2}$ an ounce of the oxide of manganese; 4 grains of purple precipitate of gold; and $1\frac{1}{2}$ ounce of nitre. The following receipt is for the garnet:—glass, 2 ounces; glass of antimony, 1 ounce; cassius precipitate, 1 grain; and oxide of manganese, 1 grain.

PASTE. A mucilaginous preparation of wheaten flour, incorporated with water by boiling. Sometimes alum is put with it, to increase its power of adhesion; at other times rosin, when it has to unite slightly greasy substances.

PASTEBOARD. A thick kind of paper, made by pasting several sheets together, which are afterwards pressed or rolled to give the fabric firmness and evenness of surface.

PASTIL, or PASTILLE. A dry composition of odoriferous resinous matters, commonly employed to burn in chambers to sweeten the air. The ingredients chiefly used in the composition are gum benzoin, cinnamon, and other aromatics.

PASTIL, or PASTEL. Among painters, a sort of paste made of various colors, ground up with gum water, either separately or together, in order to make crayons to draw with on paper or parchment.

PATENT. A writ or grant in the name of the sovereign, and under the great seal; designed to secure to the proprietor of any new invention the monopoly of its advantages for the term of fourteen years, but this term is sometimes extended, under extraordinary circumstances, for a longer period. The term patent is also applied to the right conveyed, as well as to the instrument conveying it.

PATENT YELLOW. A fused chloride of lead. It is a pigment of a fine yellow color,

and considered more durable than the chromes.

PATERA. Any flat ornament upon a frieze, ceiling, &c., often accompanied with swags of flowers or drapery.

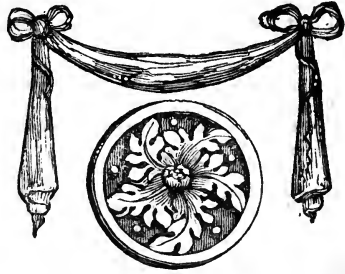

PATERNOSTERS. In architecture, a sort of ornament in shape of beads, either round or oval, used on bands, astragals, &c. (See *Bead*.)

PAVED WAY. In engineering, a certain description of tramway, but formed of stone instead of iron; it may be described as a medium between a road and a railway. There is a paved way along the Commercial Road, near London.

PAVING. The same as pavement, but usually applied to roads, and pavement to parts to be trodden upon by us.

PAVILION. A small slated building; also a projecting part of a large building.

PAVEMENT. A layer of stone or other hard substance, serving to cover or strengthen the ground in such places as are subjected to much traffic. Paving is performed with substances of very numerous kinds, with wood, granite, and other stones, in slabs or pebbles; slates, bricks, clinkers, and tiles, laid in different manners. Knob paving is formed of large gravel stones, for garden seats, &c. Bones and teeth, used for like purposes. The pavements of churches and halls are often highly ornamental, either on account

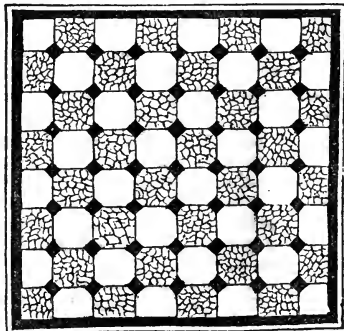

of the material employed or the manner of its arrangement, of which examples are given under the articles *Tessellated* and *Quarried*. The combinations of various colored marbles are often made highly decorative. The preceding is one of the very numerous examples of marble pavement, composed of black, white, and veined marble.

PEARL. A hard, white, shining body, generally roundish, and found in several species of the oyster family, particularly of the *Myca margaritifera*, a large species, common in the Indian seas.

PEARLS, Artificial. Small globules of thin glass, perforated with two opposite holes. They are lined with a powder or rather wash, made of the brilliant scales of a small fish, called the blay, soaked in liquid ammonia and isinglass. The ammonia evaporating leaves the scales adherent to the inner surface of the globules.

PEARLASH. A purified carbonate of potass.

PEARL MICROMETER. (See *Brewster*.)

PEARL, Mother of. (See *Mother of Pearl*.)

PEARL SHELL. (See *Mother of Pearl*.)

PEARL WHITE. Sub-muriate of bismuth, a white pigment, used chiefly as a cosmetic. It turns black upon the application of an alkali, sulphuret, or a sulphuretted gas.

PEAT. A spongy black earth, combined with decayed vegetable matter; when dried it forms a valuable fuel.

PECTIC ACID. An acid inherent in many vegetables, and which occasions the jelly-like appearance that many of them assume when boiled. It is in the form of a colorless jelly, which tastes sour; it is scarcely soluble in cold water, but more freely so in hot water.

PECTINE. A vegetable jelly, is made by mixing alcohol with the juice of ripe currants, till a gelatinous precipitate falls down. This is to be washed and dried.

PEDESTAL. The foot or base of a column or statue; when used to support a column it is mostly one-third the height of the column above it. When complete it consists of three parts; a base or foot, a square plinth or dado, and a cornice, as in the following cut:—

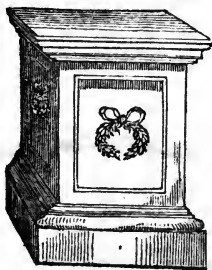

A *double* pedestal supports two columns; a *continued* pedestal sustains a range of columns, without any break or interruption in it. The pedestals of statues and vases have no determined character, being often round, oval, oblong, or of other shape.

PEDIMENT. The triangular part over the entablature at the end of a building; also a similar part over windows, gates, niches, &c. It is sometimes a portion of a circle.



PEDOMETER. A mechanical instrument, in form of a watch, consisting of various wheels, with teeth catching in one another, all disposed in the same plane; which by means of a chain or string, fastened to a person's foot, advance a notch each step, so that the number being marked on each wheel, one may number the paces, or measure exactly the distance from one place to another. (See *Perambulator*.)

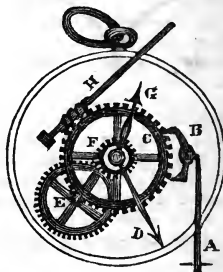

The wheel-work of the pedometer is seen above. A is a wire, fastened to the foot or leg of the pedestrian; as his foot moves backwards and forwards in walking A will act as a pendulum upon the pallet B. This moves the wheel C, and the hand D; C moves the pinion and wheel E; and this last moves the pinion F, and with it the hand G, as explained under *Perambulator*; under the wheel C is a spring to bring it forward a tooth, when such is liberated by the pallet. The hands of the dial register the number of units, tens, hundreds and thousands of steps taken. If the instrument is to be attached to a carriage wheel, an endless screw like H communicates to it the first motion, as is explained under *Perambulator*.

PEIRAMETER. An instrument, invented by Mr. J. Macneil, which indicates the amount of resistance offered by the surfaces of roads,

of different constructions, to the passing of wheel carriages, &c. The machine is as follows, and which being drawn along a road, the resistance is indicated by the dial plate at the top.

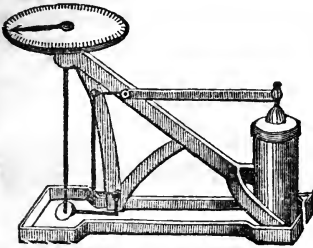

PELECOID. A peculiar-shaped curve, formed somewhat like the head of a hatchet; or contained under the two inverted quadrantal arcs A B and A D, and the semi-circle B C D.

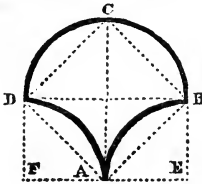

The area of the pelecoid is demonstrated to be equal to the square A B C D, and that again to the rectangle E B D F. It is equal to the square A B C D, because it wants of the lower half of the square the two segments A B, A D, which are equal to the two segments B C, C D, by which it exceeds it on the upper half.

PELLET. A Gothic architectural ornament, consisting of plain, flat, circular pieces or pellets, arranged along a fascia or band, at equal distances.



PELLICLE. A thin skin which forms over various liquids, &c.; also a scum, or an apparent dross, which is seen on the top of the solutions of salts when the solution is saturated.

PELTRY. Synonymous with fur, or the skins of different kinds of wild animals that are found in cold countries. As they are first received, they are called peltry; when tanned or otherwise prepared for use, they are *furs*.

PEN. An instrument for writing with a liquid. Pens are of various kinds:—First, quill pens, or such as are cut by a knife out of a common goose-quill. Second, such as are tipped with metal, after having been thus cut; and metallic or steel pens, such as are now in common use. The latter are very varied in form, as will be seen below. Each shape has its advocates, and numerous contrivances have been adopted to give greater elasticity to the nib, which is one of the greatest defects of this description of pen.

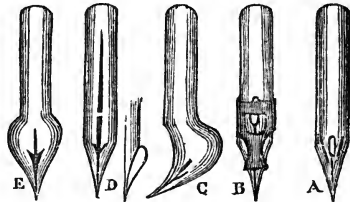

A, is Perry's *three-slit* pen. B, Perry's *regulating* pen. C, Mordant's *oblique* pen. D, Mordant's *three-nibbed* pen, the extra nib being cut out of the metal above the slit and turned down to form a triangle with the other nibs; and E, is the *lunar* pen or the *spade* pen.

PENS, Dotting, for writing music, consist of a small brass cylinder, in which a pin of the same material works vertically, being kept down and projecting about the tenth of an inch, by a spiral spring in the upper part of the pen; an opening about half way up receives the ink.

PEN, Drawing or Ruling. (See *Bow Pen*.)

PEN, Fountain, or Hydraulic Pen. A pen so contrived as to hold a quantity of ink that it may serve both for pen and ink-stand. A very simple one may be made with a common quill pen, by filling the barrel of it with ink, then stopping it with a plug of wood, leaving a slight cavity next the slit of the pen for the ink to flow out, which it must only do when a slight shake is given to the pen.

PEN, Music. A ruling pen so contrived as to draw the five lines of music at once. It consists of a parallelogram of brass, terminating in five slit points, communicating with a reservoir above, in which the ink is placed.



PENCIL. In painting, an instrument employed by painters in laying on their colors. They differ from tools and brushes only in being smaller, more delicately made, and of

finer materials. The chief substances employed in their manufacture are camel's, badger's, and squirrel's hair; the latter forms those pencils known as yellow *fitch*. The down of swans is sometimes used. These materials are fastened at the thicker end by a piece of strong thread, and inclosed in the barrel of a quill. All good pencils, upon being drawn through the lips, come to a fine point. In drawing, a pencil consists of a long slip of black-lead or colored chalk, inclosed in a round stick of cedar wood.

PENCIL, Ever-pointed. A contrivance patented by Mr. Mordant, in 1823. The pencil case, which is of metal, has a slider actuated by a screw, for the purpose of projecting forward a little cylinder of black lead, as it wears away; the thickness of the lead being so small as not to need cutting. The figure is a section of the pencil case:—The black rod A is the black lead; immediately behind this is a wire E, which is attached to the screw B, and beyond that is a guide C, passing through a small hole in the partition at D. The nozzle being kept from moving while the barrel of the pencil case is turned round, or *vice versâ*, the lead is drawn out or in as required.



PENCIL DRAWINGS. Drawings which are made by the aid of the black-lead pencil only.

PENCIL OF RAYS. In optics, denotes a number of rays diverging from some luminous point, which, after falling upon and passing through a lens, converge again on entering the eye.

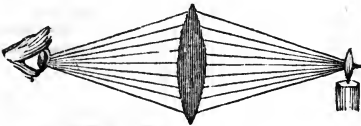

PENDANT. A sculptured ornament, suspended from a Gothic roof, from the intersection of the ribs or bracketing.



PENDENTIVE. Any part of a vault or ceiling which projects beyond the perpendicular of the walls.

PENDENTIVE BRACKETING. A cove bracketing, springing from the walls of an apartment upwards to the ceiling, so as to form the horizontal part into a curve.

PENDULUM. Any heavy body so suspended that it may vibrate or swing backwards and forwards, about some fixed point, by the alternate action of momentum and gravity, after having been once set in motion. The vibrations of a pendulum are called its oscillations; the time of each being counted from the time of its descent from the highest point on one side till it attains the highest point on the opposite side. The time occupied in a single oscillation depends upon the length of the pendulum, but the distance the weight travels, or the length of the arc, is in proportion to its weight. If, therefore, a clock go too fast, the pendulum must be lengthened; if too slow, it must be shortened; making it heavier or lighter will not affect the rate of going of the clock.

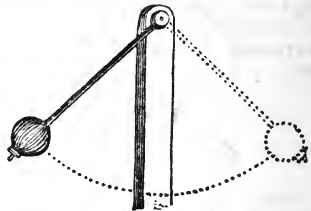

PENDULUM, Ballistic. (See *Ballistic*.)

PENDULUM, Compensation. A pendulum which is so constructed that it always retains precisely the same length, notwithstanding the effect of heat and cold expanding and contracting the length of the rod. (See *Gridiron, Reed, &c.*)

PENETRABILITY. The capability of being penetrated.

PENETRATION. The act of piercing one solid body by another in motion. Thus, a bullet fired from a gun penetrates a board. We often use the term with considerably greater latitude, and say that a liquid penetrates the earth; steam penetrates into our apartments. The word permeates or insinuates itself would be better; penetrating signifying rather a forcible entry of a solid into another solid.

PENUMBRA. A faint or partial shade, observed between the perfect shadow and the fall of light in an eclipse. This arises from the magnitude of the sun, for were he only a luminous point, the shadow would be every where perfect; but in consequence of his diameter it happens, that a place which though not illuminated by the whole body of the sun may, notwithstanding, receive a part

of his rays. This may be illustrated as follows:—

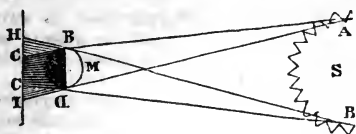

Let S be the sun and M the moon; then it is obvious that since luminous rays proceed from every part of the sun's disc, there will be no part of the shadow in which the light will be totally intercepted, except that included within the rays, proceeding from the extreme edges of the sun and moon A B C, and E D C; the other part of the shadow, namely, from C to H, and I, experiencing only a partial obscuration. Thus, a spectator of a total eclipse is situated in the umbra or real shadow; the spectator of a partial eclipse in the penumbra; and beyond the edge of this the eclipse is invisible.

PENSTOCK. PENTROUGH. An instrument intended to regulate the supply of water to a mill or water-wheel.

PENTAGON. A figure of five sides and angles.

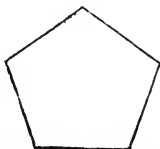

PENTAGRAPH. An instrument for copying designs, in any proportion to the original. It is of brass, and consists of four levers, A B C D, the two longest of which, A and B, are jointed together at their ends, and to the levers at the others; thus, the instrument always forms a parallelogram. F, G, and H are three tubes upon the levers, two of which, F and G, slide along, and can be fixed at any point by screws. If either of these points be made a fixture; for example, H; a drawing be placed under another point, as G; and a piece of white paper be placed under the third point F, where there is a pencil; upon moving the point at G over the lines of the drawing, it will be found that the pencil point at F will trace pre-

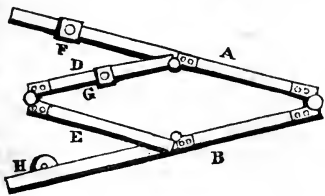

cisely corresponding lines on the white paper beneath it, which will bear a proportion of size with the original, according to situations at which the sliding pieces G and F have been set.

PENTASTYLE. A portico of five columns.



PEPYS'S BALNEO, OR FILTER BATH, being made in the shape of a filtering bag. It is a vessel of tin, shaped as represented; within this is a second vessel which fits into the first, of a conical shape, and made of glass. When any precipitate is to be dried, such as an explosive compound, the outer vessel is partly filled with water, boiling or heated to any other certain degree, and the precipitate is placed in the inner vessel; the point dipping into the water becomes heated, and consequently the precipitate dries.

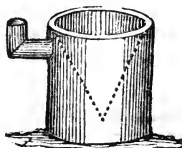

PEPYS'S BLOW-PIPE. (See *Blow-Pipe*.)

PEPYS'S EUDIOMETER. (See *Eudiometer*.)

PEPYS'S GAS-HOLDER. (See *Gas-Holder*.)

PER. In chemical words implies the highest degree of oxydation, &c., of which the substance is known to be capable; thus, we say a peroxyde, peracetic acid, perfluorine, &c.

PERAMBULATOR, OR MEASURING WHEEL. An instrument which being run along a road or other level surface indicates and registers the exact distance it passes over. The general form of the instrument, and its system of wheel-work, is seen as follows:—

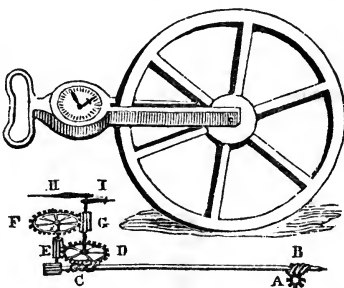

The wheel is $8\frac{1}{2}$ feet in circumference, and consequently measures exactly a pole in every two revolutions. The number of revolu-

tions made, and consequently the distance passed over, is seen on the dial-plate, where there are two hands, one moving round a circle, upon which are inscribed yards, poles, and furlongs; the other, that is the shorter hand, indicates the number of miles travelled. The movement will be seen in the lower figure. A is a small pinion fitted on to the axis of the measuring wheel. This pinion turns the perpetual screw B; and, of course, the second perpetual screw C, which is upon the same arbor, C turns D, and to the arbor of D is fastened the longer hand H, which moves around the dial-plate in forty poles or one furlong, consequently in eighty revolutions of the wheel. The wheel D, besides moving the hand H, moves also the pinion E, and the wheel F, which is united to it. The wheel F moves the pinion G, and to this is attached the second hand I, which it will be observed is upon the same arbor as H, like the two hands of a clock. The hand I registers furlongs and miles; ten miles being complete when it has passed round its appointed circle.

PERBEND, PERPENT, or THOROUGH. A term applied to the heading stones of a wall when they extend entirely from one side of it to the other.

PERCHLORIC ACID. Synonymous with the hydro-chloric acid.

PERCOLATOR. A filtering machine.

PERCUSSION. The striking of one body against another, or the shock arising from the collision of two bodies. It is either *direct* or *oblique*. Direct percussion is when the impulse takes place in a line perpendicular to the plane of impact. Percussion in any other direction is called oblique.

PERCUSSION, Centre of. In striking any body with a bar or lever, it is always found that if the blow be given at or near the end of the bar, it will jar, or attempt to fly out of the hand; and if the blow be given by that part of the bar near the hand, it will also jar and attempt to fly from it. Now there evidently must be a point between these two, where if a stroke be given, the full effect of the blow will be sensible, and the bar will remain at rest, without jarring the hand; this is called the centre of percussion, and in a straight uniform bar it will be at the distance of one-third the length of the bar from the outer end of it.

PERCUSSION, Force of. The momentum of one body communicated to it by the momentum of another; thus, a wedge penetrates into a fissure in proportion to the force of percussion, the strength of the blow, or the degree of momentum which it receives from a mallet or other body striking it.

PERCUSSION POWDER, for fire-arms, is made thus:—10 parts of gunpowder is dissolved in water, then filtered, and the paste

left is mixed with $5\frac{1}{2}$ parts of finely-powdered chlorate of potass, and a drop of it poured into each of the little percussion caps used with fire-arms; when dry it is fit for use. As this composition corrodes any part that it touches, the fulminate of mercury is now more generally used.

PERIDROME. That open space or gallery on the sides of a temple or other building which is between the side columns and the walls, and used as a promenade among the ancients. Pronaos applies to the same part in the front of a temple.

PERIGEE. That part of the moon's orbit in which she is at the least distance from the earth; contrary to apogee, or the greatest distance. (See *Apogee*.)

PERIHELION, or PERIHELUM. That point in the orbit of a planet or comet which is nearest to the sun, as opposed to aphelion, the most distant point. (See *Aphelion*.)

PERIMETER. In geometry, the boundary of any body, whatever be its shape; of a circular body it is usually called a periphery, or circumference.

PERIOD. In astronomy, the time in which a planet or satellite makes one entire revolution in its orbit, or returns again to the same point in the heavens. In chronology, an epoch or space of time, by which events are reckoned. In arithmetic, it signifies any particular division of numbers. Thus we say, divide the number into periods of 2 figures each, or 3 figures each, as the case may be. In printing, the period or full-point signifies a complete termination of a sentence, or very often a contraction, as A. M., &c. In decimal arithmetic, a period is put between the whole number and the decimals, as in 24'833.

PERIOECIANS. In geography, those people who inhabit the same parallel of latitude.

PERIPATETIC PHILOSOPHY. The system of philosophy taught and established by Aristotle. The word comes from the Greek, and signifies to walk, because the students were taught and argued while walking in the Lyceum.

PERIPHERY. The circumference or bounding line of a circle, ellipsis, parabola, or other regular curvilinear figure.

PERIPUTIST, Patent. A small cooking apparatus, invented by Mr. Welles. It is formed of tin, and consists of several vessels placed over each other, as is seen in the following section. A is a conical vessel holding burning charcoal. B a vessel surrounding it, containing water. C the ash-hole. D a steaming vessel with a perforated bottom, and a conical tube in the centre to fit over the fire-place cone; this is open above, and is furnished with holes for the emission of the steam and vapour from the fire; above this is a saucepan E, and instead

of a lid to the saucepan, a coffee-pot, egg boiler, &c. F is placed.

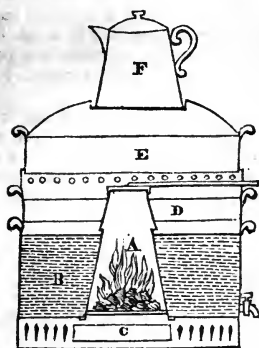

PERIPTERE. Any building surrounded with a single row of columns, as the Parthenon, at Athens; the Temple of Concord, at Agrigentum, &c.

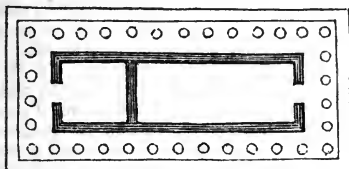

PERISCHII. A term formerly applied to the inhabitants of the two frigid zones, because their shadows at times make an entire circumference in one day.

PERISCOPIC. A name given by Dr. Wollaston to such spectacles as allow the eye a considerable latitude without fatigue. Their form is that of a meniscus glass with the concave side turned towards the eye; they are used for spectacles, microscopes, &c. When spectacles, thus rendered periscopic, are intended for long-sighted persons, or old age, the anterior surface, or that next the object, is formed spherically convex, with a curve deeper than the concave, so as both to gain the required power, and to compensate for the divergency occasioned by the concave side; this form is shown in fig. A. The contrary ratio of concavity and convexity will, of course, be necessary for short-sighted persons, as is seen at B.

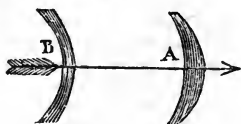

PERISCOPIC COMBINATION OF LENSES. (See *Herschel*.)

PERISTYLE. A building encompassed by a row of columns on the inside, by which it is distinguished from periptere, or a building having a row around the outside. The terms are however often used synonymously.

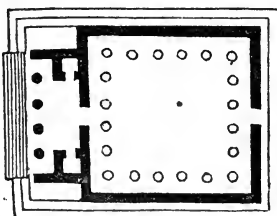

PERITROCHIUM. A word in mechanics, signifying a wheel, as the axis in peritrochio; synonymous with the wheel and axis, (which see.)

PERLATE SALT AND ACID. The name of the perlate acid was given by Bergman to the acidulous phosphate of soda; Haupt having called the phosphate of soda the perlate salt.

PERMANENT. Remaining through every change, as a permanent color, a permanent dye, &c. are such as are not affected by the sun, by washing, or the usual casualties to which it may be subjected.

PERMANENT INK FOR LINEN. (See *Marking Ink*.)

PERMANENT WHITE, OR CONSTANT WHITE. The sulphate of barytes, a valuable color for many purposes, as no chemical substance will decompose it or change its color.

PERMANENT WAY. The finished road of a railway.

PERMANGANIC ACID. Manganic or manganic acid united to an extra portion of oxygen, containing $3\frac{1}{2}$ atoms of oxygen to every one of manganese.

PERMUTATIONS. Changes in the position of things, differing from combinations in this—that the latter has no reference to the order in which the quantities are combined whereas in permutations this order is considered.

PERPENDICULAR. A line falling directly upon another line so as to make equal angles on each side. Thus, A B is perpendicular to C D, because the angle A B C is equal to A B D. E F is also perpendicular to G H for the same reason. In both these cases, and in all others, the two angles on the sides of the perpendicular are right angles, and must be so; therefore when one line meets another and makes a right angle with it, the lines are perpendicular to each other, whatever be their position relative to our view of

them. However, in a right-angled triangle the perpendicular is generally considered to be that line which constitutes one of the legs of the right angle, and which, at the same time, most nearly approximates to an erect position in the diagram. Thus EF , HF , may each be called the perpendicular of the triangle EFH , according as we view the figure, the other leg being the base and the longer line the hypotenuse. An object is said to stand perpendicularly where a line let fall from its centre of gravity is perpendicular to the general level of the earth's surface, or which line, if produced, would reach to the earth's centre.

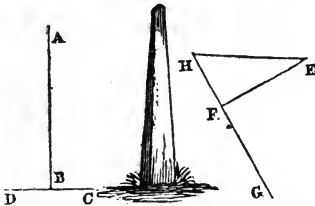

PERPENDICULAR TO A CURVE, is a line perpendicular to a tangent of the curve at that point.

PERPENDICULAR LIFT. A contrivance on canals for passing the boats from one level to another.

PERPET STONES. (See *Perbend*.)

PERPETUAL LEVER. Another name given to a wheel of any kind, a wheel being in fact a series of levers or spokes, the fulcrum of which is the centre of the axis; the moving power the circumference of the axis; and the weight, whatever is moved by the wheel, so that it may be considered as a perpetual or uninterrupted series of levers, one or other of which is always acting. In other cases the circumference of the wheel is the power.

PERPETUAL MOTION, is that which possesses within itself the principle of motion, and that of sufficient force to overcome the friction of its parts. In nature there are numerous perpetual motions, such as the revolution of the heavenly bodies, the tides, organic and inorganic changes, vital functions, &c. Artificial or mechanical perpetual motion has never yet been attained, though the subject has occupied the attention of the ingenious for many ages, the nearest approach to it being, perhaps, the dry electrical pile of De Luc.

PERPETUAL SCREW, OR ENDLESS SCREW, is a peculiar kind of axis, having upon it a spiral thread, which works a toothed wheel, which it turns round with a great decrease of velocity by proportionate increase of power, at the same time the direction of

motion is altered from one direction to another, varying 90° from it.

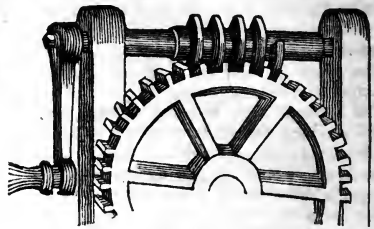

PERPETUITY. In the doctrine of annuities, is the number of years in which the simple interest of any principal sum will amount to the same as the principal itself; or it is the quantity arising from dividing 100 by the rate per cent. for one year. Thus, the perpetuity at 5 per cent. is 20 years; at 4 per cent. 25 years.

PERSIAN WHEEL. (See *Noria*.)

PERSIANS. Male figures used instead of columns to support an entablature; the female figures are called caryatides.

PERSPECTIVE. The art of representing objects on a definite surface, so as to affect the eye when seen from a certain position, in the same manner as the object itself would when the eye is fixed at the same or a corresponding point; or, supposing we look at a number of houses or trees, dispersed over a view, through a pane of glass, and draw upon that glass all the lines apparent through it, such lines would represent the houses in true *linear* perspective; and such as are farthest from the eye, as they appear in reality to be the smallest, so they would be represented. Again, if we color such a picture as it appears through the same medium, the effect of distance will be heightened, and our picture will have the colors brighter and more distinct in the fore-ground, and gradually becoming more and more

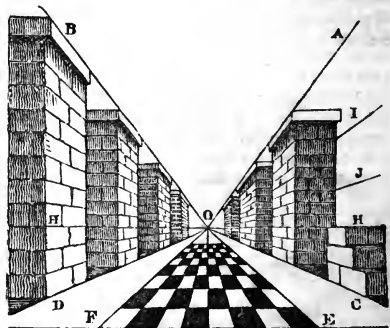

obscure as the objects are farther off; this is called *aerial perspective*. In linear perspective different terms are used to designate the various parts of a picture, and the lines necessary to construct that picture according to the rules of the art. In the cut the principal of these are seen.

The horizon is the line that extends horizontally across the picture at the height of the draughtsman's eye; this is seen at H H. A particular point in this, exactly opposite the eye, is called the centre of the picture O; all the horizontal lines of the picture tend to this point, as EO, CO, HO, IO, JO, AO, BO, &c.; all these lines are called *vanishing lines*; the line connecting the centre of the picture and the eye is called the principal *visual ray*; and its length is the *distance* of the picture. Whatever is delineated is called an *original object*. The surface upon which these objects stand is the *ground plane*, and the picture itself is the *perspective plane*.

PERSPECTIVE, Isometrical. A particular kind of perspective, in which the objects are always represented at a particular angle, showing at the same time three contiguous sides, just the same as would be observed with a cube, upon looking at it exactly over one of its angles, when, as is seen in the margin, precisely one-half of the cube is visible; and any thing resting upon either of the three apparent sides, would, of course, be visible also. This kind of perspective, therefore, has the advantage of showing at the same time a correct view of two horizontal sides of an object, and the top of it also. In depicting machinery, masses of buildings, or plots of estates, it is most valuable, and the practice so easy that there are no difficulties in its attainment, as there are in the ordinary linear perspective. The following cut shows the application of isometrical perspective in depicting a building and garden:—

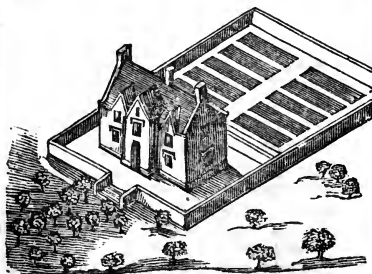

PERSPECTIVE. The name given to a

small two-drawer pocket telescope, which, when closed, is about 4 inches long. It is not calculated for distances above 3 or 4 miles.

PERSPECTOGRAPH. An instrument for the mechanical drawing of objects in perspective. The following is one invented by Mr. Turrell, and described by him in the "Transactions of the Society of Arts," vol. xxxii.

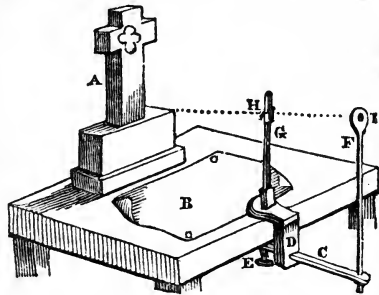

Suppose A to be an object to be delineated on the paper B. C is a bar of metal or wood, which passes through the clamp D, and which is held to the table by the screw E. The rod F slides up and down through the end of the bar C. G is another rod having a joint at bottom, and a sliding piece H. To use the instrument, look through the hole I, and adjust H so that you can see a certain point of the object through a hole in H; then turn the rod G downwards, and the point attached to H will make a mark upon the paper. A series of these marks being thus taken, and lines drawn from one to the other, as required, will give an outline of the original object.

PETRIFACTIONS. Stony matters deposited either in the way of incrustation, or within the cavities of organized bodies, are called petrifications; also all organic substances which have become so hard as to assume the appearance and character of stone.

PETROLEUM. A fluid bitumen of a brown, black, or dingy color, analogous to naphtha in composition, but of a rather greater consistence.

PEWTER. A well-known alloy; made by melting 6 oz. of copper, and when melted, adding 7 lbs. of tin, 1 lb. of lead, and 2 oz. of zinc; or for best pewter, 100 parts of tin and 17 parts of regulus of antimony.

PHANTASMAGORIA. Denotes a remarkable optical illusion arising from a particular application of the magic lantern. In the exhibition of this spectacle, the spectators are placed in a dark room having a transparent screen between them and the lantern, which screen ought to be let down after the lights are withdrawn, and unknown to the spectators. The lantern being then properly

tected in the tar of beech wood. It constitutes one-sixth of this tar.

PICK. A hammer for dressing the stones of a flour mill.

PICROMEL. A black bitter principle, supposed to be peculiar to the bile or gall of animals.

PICROTOXINE. An intensely bitter, poisonous, vegetable principle, extracted from the seed of the menispermum cocculus, (*cocculus indicus*.)

PICTURE. An imitation or representation by lines and colors of any natural or artificial object or appearance.

PIER. A square or rectangular pilaster of stone, brick-work, &c., not fashioned in classical proportions; sometimes imbedded in the wall; sometimes free; as the piers which support a wall, arch, bridge, &c. It has no base or capital. Pier is also a strong marine erection, extending from the shore to a considerable distance in the sea, and by breaking the violence of the waves forming a harbour within or towards the leeward of it, for the protection of shipping and other craft. If employed merely for landing goods and passengers it is often called a jetty.

PIG IRON. Also known by the name of crude iron or cast iron, never having been subjected to the process of hammering.

PIGMENT. (See *Paint*.)

PILASTER. A square pier of brick-work or stone, with similar capital ornaments, proportions, and projections, as a column. It is occasionally detached from a wall, but mostly so imbedded in it as not to show above one-fourth its thickness. These are called by Vitruvius *antæ*, while *parastrata* signified those which were free. Pilasters, in carpentry, are square, flat columns or ornaments, fluted or reeded, and made of deal, with moulded caps and bases, and placed either on broad styles or flat upright members of a building to remove the flat unornamented appearance of such parts.

PILASTER, Demi. A pilaster that supports an arch; it generally stands against a pier.

PILE. A word to signify an extensive mass or body of building.

PILES. Rows of stakes or timbers driven deep into the ground to make wooden bridges over rivers, water inclosures, coffer dams, &c., and often to erect edifices upon.

PILE, Galvanic, or Voltaic. A number of galvanic circles united together so as to form a compound series of elements acting in unison, or galvanic battery. Those batteries may more peculiarly be called piles, in which the elements are piled or heaped up upon each other, as is seen in the following series, which is built up of two different metals, such as copper and zinc, with a piece of damped cloth between each pair, in the manner of De Luc's dry pile or column, and

according to the following cut, where the white represents the copper, the black the zinc, and the shaded intervals the moistened cloth. If a pile of this kind, made of penny pieces, and similar pieces of zinc be built up till there are twenty or more of each, a slight galvanic shock may be felt by touching the ends with the fingers, they being previously moistened. (See *Circle, Battery, and De Luc*.)

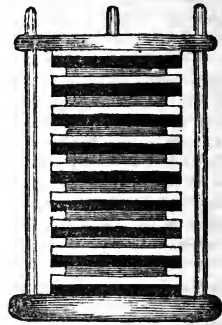

PILE, Thermo-Electric. (See *Melloni*.)

PILE ENGINE. A machine for driving piles into the ground. There are several kinds of pile engines, the principle of all of which is to raise a great weight gradually by machinery;

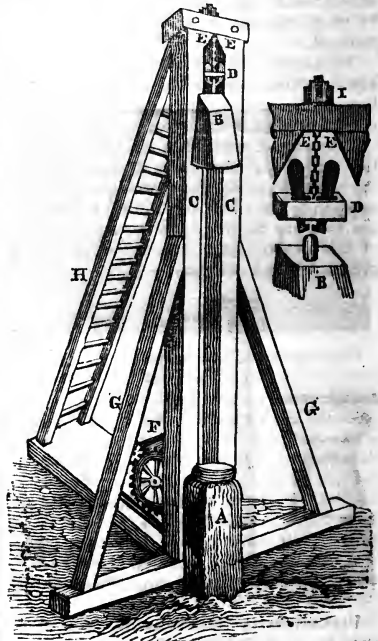

or the united strength of several men to a height of 30 or 40 feet, and then letting it fall suddenly upon the end of the pile, until by reiterated blows it is driven into the ground. The foregoing cut shows the ordinary pile engine, which may be thus described:—A is the pile to be driven into the ground. B is the *ram*, or a large heavy mass of iron, which being let fall from the top of the machine on to the head of the pile, drives it downwards. At the back of the part of the ram which is seen are two projecting pieces, which fit into grooves cut in the sides of the uprights C C. The object of these projecting pieces and grooves is to guide the ram in its passage up and down. There is a staple on the top of the ram, which is caught hold of by two hooks, as seen at D in the side cut. This part of the apparatus is called the *monkey*, and is drawn up by a chain, passing over the pulley I, and coming down to the crab or crane F, where the men work. As soon as the monkey and ram get to the top, the upper ends of the monkey press against the inclined planes E E, and by this means the hooks below are separated, and let go the ram. When D is suffered to run down, its own weight brings it to the bottom, and attaches it a second time to the ram.

PILE PLANKS, are planks whose ends are sharpened to drive into any canal or water, close to each other, in order to form a dam, by which the water may be stopped or discharged.

PILLAGE. A word sometimes used for a square pillar standing behind a column to bear up the arches, having a round base and capital as a pillar has.

PILLAR. A round column, out of proportion, either too massive or too slender; thus the thick supports of a Gothic vault, and the apparently light iron rods, now so much in use to carry the fronts of houses, &c., are of this description. The following are all pillars, but not columns:—

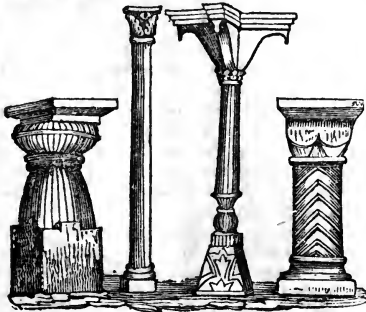

PILLOWED, OR PULVINATED. A term applied to a rounded frieze.

PIN. To strike a piece of metal with the narrow end of a hammer to form dents and produce expansion. For example, the iron hoops of casks are made larger at one edge than at the other by this means, in order that the hoop may better fit the tapering surface of the cask.

PINCERS. A tool formed by placing two levers on one fulcrum, for holding bodies firmly.

PINCHBECK. An alloy composed of 5 ounces of copper and 1 ounce of zinc, melted together. The zinc must not be added till the copper is fused. Some use only half the quantity of zinc, in which proportion the alloy is more easily worked, especially in the making of jewellery.

PINEY TALLOW. A concrete fat obtained by boiling with water the fruit of the *Vateria Indica*, a tree common upon the Malabar coast. It is a substance intermediate between tallow and wax, is white or yellowish, and forms excellent candles.

PINIC ACID. A hard brittle substance, procured by digesting common rosin in pure alcohol, mixing with the clear solution another alcoholic solution of acetate of copper; thus a *pinate* of copper is formed. This substance washed in alcohol and hydrochloric acid furnishes a solution, from which water throws down the pinic acid.

PINION. A small toothed wheel, not in general having more than twelve teeth, leaves, or pallets, as they are here called; also when two cog wheels work in each other, the smaller is often called a pinion. The cut shows various applications of the pinion. A is a winch, turning the pinion B, which turns the wheel C, while this latter turns the two pinions D and E. A pinion may also turn, or be turned by a rack as at F.

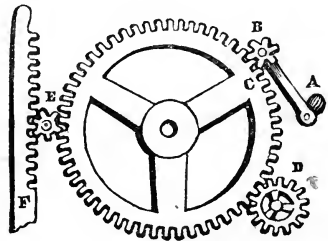

PINNING. The fastening of things together with small pins, bolts, pegs, &c.

PIPERING. A crystalline substance extracted from black pepper by means of alcohol. It is soluble in alcohol, but not in water, and has scarcely any taste or color.

PIPE-CLAY. A kind of aluminous clay, fine, plastic, and tenacious, which requires a considerable degree of heat to fuse it, and then forms a white or cream-colored hard

substance, which at first rapidly absorbs moisture.

PINNACLE. A pointed termination to a turret, buttress, &c.

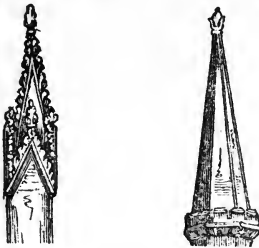

PIPES. Vessels employed for the conveyance of any fluid, and which are usually of a cylindrical shape, and made of iron or lead. Thus, we have main or large pipes, and service or small pipes; or designating them by the use to which they are put, we may say gas-pipes, water-pipes, &c. Pipe is also a measure of capacity, used for wine, and containing according to the kind of wine from 110 to 136, or 140 gallons.

PIRN. The wound yarn that is on a weaver's shuttle.

PISE. A style of building in which the walls are made of a kind of clayey mortar mixed with straws, which, when dry, forms a solid mass; such buildings are extremely common in many of the western and northern countries.

PISTON. A plug made to fit tight and move up and down a cylinder in pumps and other hydraulic machines, the steam engine, air pump, &c.

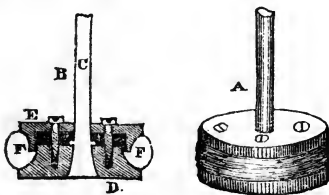

PISTON ROD. The rod connected with a piston, being passed through the centre of it and secured by means of a screw or key, the other end of the piston rod being attached to the pump handle; or if belonging to a steam cylinder to the parallel motion.

PITCH. A hard, black, bituminous substance, obtained by boiling wood tar in an open vessel till the volatile matters are driven off.

PITCH. In architecture, the proportion between the height and the span of a roof. If the rafters exceed in length the width of

the building, the roof is said to be of the *Elizabethan*, or *knife-edge pitch*, as $A B C$; if they are equal to the width, the pitch is *Gothic*, as $A D C$; if of two-thirds the width, the roof is said to be of a *true pitch*, or of the *Roman pitch*, as $A E C$; a roof still flatter than this is the *Grecian pitch*, as $A F C$.

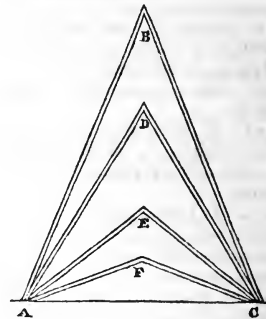

PITCH, Mineral. (See *Asphaltum* and *Bitumen*.)

PITCH OF A WHEEL. The distance of the centres of two teeth, measured upon their pitch line.

PITCH LINES. Millwrights call by this term the relative circles of wheels which work one in the other; called also proportional lines or circles.

PIT COAL. A general name for the common coals used for firing, such being distinguished by this name from charcoal.

PITH BALLS. Small balls made of the pith of the elder tree, and used in numerous electrical experiments to show the effects of attraction and repulsion.

PITH BALLS, Dancing. (See *Dancing*.)

PITACALL. One of the six curious substances discovered to be in the tar of beech wood. It is a dark blue solid substance somewhat like indigo, assumes a metallic fiery lustre on friction, and varies in tint from copper to golden. It is void of taste and smell, is diffusible in water, and dyes a fast blue upon linen and cotton goods with the usual mordants.

PIVOT. A short shaft or point upon which a body turns or vibrates.

PLASTER, or PLASTER. Any thing of a thick consistence and an adhesive property, used to cover over a surface for the preservation of it from injury.

PLASTER, or PLASTER OF PARIS. Calcined gypsum, used by the builder and the artist to form casts and moulds of various ornaments; to mend defective places in decorative ceilings, cornices, and similar objects, and to unite marble and other stonework together.

PLAFOND. Synonymous with soffit or ceiling.

PLAN. The representation of something drawn on a flat surface, as maps, charts, draughts of the foundations or other sections of buildings, ships, &c. If all the parts are delineated in their true relative proportions, it is called a *geometrical plan*; if the parts diminish in proportion to their distance, it is a *perspective plan*.

PLAIN ANGLE. An angle contained under two lines or surfaces, so called in contradistinction to a solid angle.

PLAIN TRIGONOMETRY. (See *Trigonometry*.)

PLANE. In carpentry, is a tool used to produce straight, flat, and even surfaces upon wood. The different kinds of planes are very numerous.

PLANE. In geometry, is a completely flat or even surface, or one with which a straight line will every where coincide. They may be *horizontal*, *vertical*, or *perpendicular*, and *inclined* or *oblique*. Planes are also frequently used for imaginary surfaces, supposed to cut and pass through solid bodies, and on this construction is founded the whole doctrine of conic sections. In astronomy, the same term is used for an ideal plane passing through certain parts or points of the heavens, as the plane of the horizon, of the ecliptic, equator, &c., by which is to be understood certain ideal planes passing through those circles of the sphere, or on which they are supposed to be described.

PLANE OF CLEAVAGE IN CRYSTALS AND STONES. Those who are in the habit of cutting gems know that they will only afford smooth surfaces in certain directions. These are called their planes of cleavage.

PLANE, Geometrical. The same as ground plane. (See *Perspective*.)

PLANE, Inclined. (See *Inclined*.)

PLANE, Perspective. (See *Perspective*.)

PLANE CHART. In navigation, a sea chart constructed on the supposition of the earth and sea being an extended plane surface. Such charts have, consequently, the meridians represented as lines parallel with each other.

PLANE SAILING. The art of performing the several reckonings necessary for conducting a ship on the ocean, on the principles of the plane chart.

PLANE TABLE. An instrument formerly much used in surveying for taking angles, and laying down the work in the field as it was measured. It consists of a board upon which the paper is laid, and inclosed by a frame, graduated along the sides, by which the lines were plotted. It had a compass and pair of sights connected with it.

PLANIMETRY. That part of geometry which measures and considers plane figures

or superficies only; for example, land and sea surveying.

PLANISPHERE. A projection of the sphere and of the several circles thereof on a plane, as upon paper or the like. In this sense, maps of the heavens or the earth, in which are exhibited the meridians, parallels, and other circles, are called planispheres.

PLANK. A general name for all timber excepting fir, which is from 1 inch and a half to 4 inches thick; if of less dimensions it is called a *board*.

PLANK-HOOK. A pole with an iron hook at the end, with which navigators shift their runs or wheeling planks, as occasion requires.

PLANO-CONCAVE. Flat on one side and concave on the other. (See *Lens*.)

PLANO-CONVEX. Any thing which is flat on one side and convex on the other. (See *Lens*.)

PLANTING. In architecture, denotes the laying the first courses of stone on the foundation, according to the measures, with all the exactness possible.

PLANET. A wandering star, as distinguished from such as are fixed or stationary, and likewise distinguished from the comets, which are also wandering, by the planets revolving in orbits, which are much less concentric. They are often called *primary* planets, having the sun as their centre of rotation, while the *secondary* planets or moon revolve around their primaries. The names and characters given to the planets belonging to our system, and which are all that we know positively to exist are Mercury ☿, Venus ♀, the Earth ⊕, Mars ♂, Jupiter ♃, Saturn ♄, and Herschel, or the Georgium Sidus ♃, besides four very small ones between the orbits of Mars and Jupiter, called sometimes Asteroids; they are Ceres, Juno, Pallas, and Vesta. The relative sizes of the principal planets may be inferred from the following comparative cut of them:—

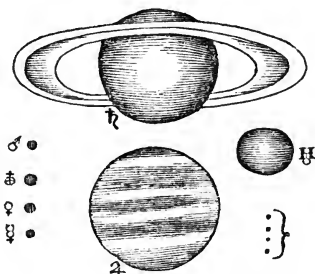

It is to be further observed, that the extent of their orbits varies no less than their relative sizes. Mercury being but 37 millions of miles from the sun, while Herschel is

1800 millions of miles; also those which are nearest the centre move with a greater velocity than those which are remote, and all their motions are performed in the same order from west to east, or according to the order of the signs of the zodiac. They have also each a rotatory motion about their own axes, the time of which, however, appears to have no relation with regard to their magnitude, or their distance from the sun. For other particulars, see each planet by its name; also *Kepler's laws, Asterioids, &c.*

PLANETS, Elements of the, are certain quantities which are necessary to be known in order to determine the theory of their elliptic motion. Astronomers reckon seven of these elements, of which five relate to their elliptic motion: viz. 1. The duration of the sidereal revolution. 2. The mean distance. 3. The eccentricity. 4. The mean longitude of the planet at any given epoch. 5. The longitude of the perihelion at the same epoch. The other elements relate to the position of the orbits and are—1. The longitude at a given epoch of the nodes of the orbit with the ecliptic. 2. The inclination of the orbit to this plane.

PLANETARIUM. (See *Orrery.*)

PLANETARY. Something relating to the planets.

PLANETARY SYSTEM. (See *Solar System.*)

PLAT BAND. A square moulding, having projection less than its width.

PLATE ELECTRICAL MACHINE. An electrical machine, so called because a plate of glass is substituted for a cylinder. In the cut, A represents the plate of glass, which is made circular, and has a hole drilled through the centre for the admission of a spindle, so that it may be turned by the handle B. C C C C are four cushions, fixed two and two together, to rub against the glass. D D are two double flaps of black silk. E is the prime conductor, which is of metal, terminated by a ball H at one end, and after branching into two arms F F, which are bent at the part next the plate, terminating with

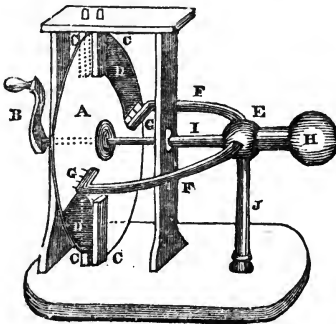

points as at G G. I and J are glass rods, to support the prime conductor. These are not both necessary, if the machine be small; the rod marked I being sufficient.

PLATE GLASS. The fine kind of glass cast in thick plates, and used for looking glasses, the better kind of windows, &c. Its composition is 300 lbs. fine sand, 200 lbs. soda, 30 lbs. lime, 2 lbs. manganese, 3 ounces cobalt azure, and 300 lbs. fragments of good glass.

PLATED WARE. Articles made of a common metal, mostly copper, and washed over with a thin coat of silver.

PLATINODE. The cathode or negative pole of a galvanic battery.

PLATINUM. The heaviest body in nature. It is a metal of a white color; malleable, ductile, tenacious, unalterable in the air; not to be melted, except by galvanism; or by the heat of the sun, concentrated by powerful lenses; nor acted upon by the most powerful acids, aqua regia alone dissolving it. When thus dissolved, it may be united to ether, forming what is called the ethereal solution. It is also capable of being welded at a white heat. Platinum unites with most of the other metals. From its hardness, infusibility, and difficulty of being acted upon by most agents, platinum is of great value for making various chemical vessels.

PLATINUM THERMOMETER. (See *Morveau.*)

PLATONIC BODIES. (See *Bodies.*)

PLATONIC YEAR, or the GREAT YEAR, is the period of time determined by the revolution of the equinoxes, upon the supposition of the precession going on uniformly till they have made one complete revolution.

PLENIUM. In philosophy, is that state of things in which every part of space, or extension, is supposed to be full of matter; in opposition to a vacuum, which is a space devoid of all matter.

PLINTH. The square part under a pedestal, forming the lowest member of a column, wall, &c.

PLOTTING. Among surveyors, the art of describing or laying down upon paper, the several angles and lines of a tract of ground, surveyed by a theodolite chain, &c.

PLOUGH, Stationer's. (See *Stationer.*)

PLUMBAGO, or GRAPHITE. The chemical name of black-lead. It is a carburet of iron, containing 95 parts of carbon to 5 of iron. It is infusible, and burns with great difficulty. It is of an iron grey color, metallic lustre, soft to the touch, and easily scratched. (See *Black-Lead.*)

PLUMBUM CORNEUM. Chloride of lead; obtained by mixing hydro-chloric acid with nitrate of lead.

PLUMMET, PLUMB LINE, or PLUMB RULE. An instrument used by masons, car-

penters, &c. to draw perpendiculars. It consists merely of a straight-edged piece of wood, having a string and a leaden ball at the end of it freely suspended, so that when the edge is made to coincide with any thing, the erect position of which is to be ascertained, the plumb *bob* hangs freely in the hole prepared for it, without inclining to either side.

PLUNGER. A solid piston, particularly such an one as is used in force pumps.

PLUS. In mathematics, the affirmative or positive sign + which signifies addition. In a similar sense, bodies are said to be electrified *plus* or positively, when they contain a greater quantity of the fluid than is natural to them.

PLUVIAMETER. (See *Rain Gauge*.)

PNEUMATIC FILTERER. (See *Palmer*.)

PNEUMATIC TELEGRAPH. An invention of Mr. Crossley, for communicating signals to a great distance by means of the impulse given to a column of water at one end of the apparatus.

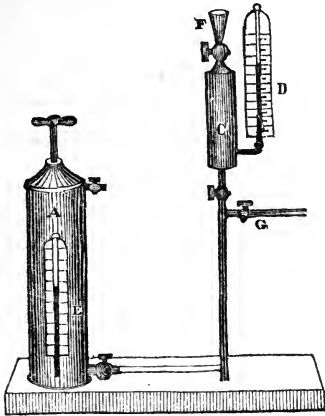

A is a cylinder of air at one extremity of the line. C is supposed to be a distant station. There is a tube which connects these places. D the index at one of the stations. Each cylinder or air vessel contains a little water, with a pipe below the surface of it. When the air at one end is compressed, the compression extends equally throughout the whole extent of the instrument, and the surface of the water being pressed upon, it rises in the gages or index tubes equally at all the stations; these being numbered, and the numbers made representative of certain previously arranged signals, communication is of course readily indicated. F is a funnel supplying the water, to produce the proper adjustment at first, and also if it should become incorrect by leakage or accident. G a pipe leading to a further station, capable of

being acted upon at the same time as the second; or by a cock, each may be shut off as required.

PNEUMATIC TROUGH. A tin box, or sometimes a tub or a basin, made so that a shelf reaches half across it, inside and near the top. The shelf is made with one or more holes through it, and a funnel-shaped piece of tin below. It is used to purify, cool, and collect such gases as are not absorbable by water. The following cut shows, at the same time, a tin pneumatic trough and its use. A is the trough, with sufficient water in it to cover the shelf B; the jar C being filled with water, by immersing it sideways in the trough, is turned upright, and slid upon the shelf, and over the hole of it. D is a retort, in which gas is being liberated. The gas passes out of the beak of the retort, up through the funnel into the jar, where it is retained; displacing the water from it, and occupying its place. For such gases as are absorbable by water, a mercury trough is used.

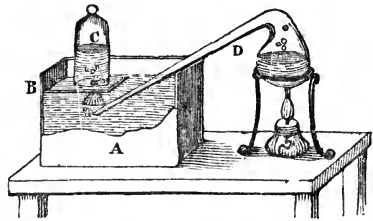

PNEUMATICS. That branch of natural philosophy which treats of the weight, pressure, elasticity, &c., of elastic fluids, but more particularly of the air. Explaining therefore the action of all those machines and phenomena which depend for their action or solution upon the above cause; such as the air-pump, barometer, thermometer, pumps, ærostation, sound, echoes, acoustics, &c.

POINT. The smallest possible space or magnitude, so small indeed as to be imaginary rather than real, and to indicate a situation rather than an entity. For example, the ends of a line are points; so also is the spot in which two lines meet, provided those two lines make an angle. Yet join the ends of the lines together, forming a continued line and the points no longer exist; so also making an angle of two lines, the four points, natural to two lines, become three points only. Any number of lines may thus unite, and their place of union will still be a single point. Among artists, a point is understood to be any sharp instrument applicable to etching or tracing; therefore called an etching point, dry point, &c. Points, as occurring in the arts and sciences, are of various denominations, meaning a particular position or situation. Thus we have vanishing point in

perspective. Point of support and of contact in mechanics. Point in the zodiac, as the first point of Aries; and numerous other points in astronomy. Point, dot, or full point in printing. Points or chief marks upon the mariner's compass, &c. The *melting* and *fusing points* of solids, and *boiling* and *freezing points* of liquids, are those degrees of heat at which melting, fusing, boiling, and freezing respectively commence. In physics, the *acting point* is the exact spot at which any impulse is given; and the *point of incidence* is where, by striking a resisting or refracting surface, the motion is changed in direction, or as relates to light, we should say refracted.

POINTED ARCH, ARCHITECTURE, &c. An arch pointed at the top, as is common in the Gothic buildings of the middle ages; indeed so common as to have occasioned the buildings, to which such arches were attached, to assume so decided a character as to be said to be built in the pointed style of architecture.

POINTING. A term applied to the finishing of the external face of the several courses of a wall. The common mortar is first scraped out, and the joints and courses cleaned, when they are filled up with fine mortar or Roman cement.

POLAR. Something situated near to the poles of the earth, the poles of a magnet, &c., or relating to such parts, as polar distance, the distance of a place of a star, &c. from the nearest pole of the earth.

POLAR CIRCLES. (See *Circle*.)

POLARISATION OF LIGHT. The means or method of changing common light into polarised light, which may be done as follows:—Let A in the following cut be a plate of glass, placed diagonally at the end of the tube M N, so that a ray of light, R A, striking against A may be reflected along the axis of the tube. At the end of another smaller tube N P, place a similar plate of glass, capable of reflecting the continued ray A C to the eye at E. If a ray strike the first glass at an angle of 56° , in a horizontal direction, and is reflected from the second glass C, at a similar angle in a vertical direction, it will become so weak as to be scarcely visible; but if the tube N P be turned round, the ray C E will become

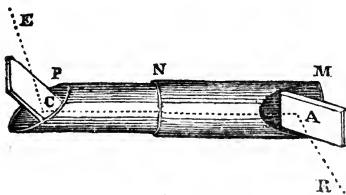

brighter and brighter, till it is thrown off horizontally; continuing to turn the tube, it will at another quarter turn be again dim; at a third quarter it will become bright again, and when turned round a whole circle it becomes, as at first, scarcely visible. This turning of the apparatus is called polarising of the light; there are other ways of polarising light.

POLARISED LIGHT. When the light of the sun is reflected from certain bodies, at particular angles, according to the nature of those bodies, or transmitted through certain transparent uncrystallised, and also through doubly refractive crystals, and these various bodies are turned round, it becomes in a measure, decomposed, one side of the ray of light presenting an appearance and properties different from the other; these two contrary sides are said to be the poles of the ray, and the whole becomes polarised light.

POLARISED LIGHT, Colors of. Let there be an apparatus constructed similar to that last described, in which the light polarised by the first plate, shown in the following cut at A, which is called the *polarising* plate, refuses to be reflected at C, or at the *analyzing* plate, it being placed vertical to the first. Let a strong sun-light fall upon A; then take a very thin film or slice of sulphate of lime or mica D F G H, and hold it or insert it between the two plates, where, previous to the interposition of the crystallised plates, the eye at E scarcely saw even a glimpse of light, it will now see the most vivid, the richest, and most varied hues, and following one another, according to the thickness of the crystal, or the manner in which it is held. If the crystal be turned round while in this situation, the colors will change at every quarter turn, becoming at one time green, at the next red, and so on.

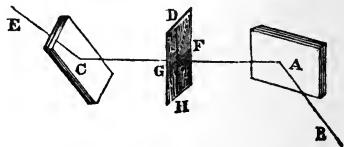

POLARISING APPARATUS. POLARISCOPE. Any instrument which is capable of showing the phenomena of polarised light, such as that already described, or that which follows.

POLARISCOPE, Oxy-Hydro. This is an apparatus to show the phenomena of polarisation of light to a number of persons at once. The name implies that the light decomposed is produced by the united effect of burning the two gases named. The burning gas is thrown upon lime, exactly as shown under *Oxy-Hydro Microscope*. The polarising apparatus is in principle what has

been already described; but having magnifying lenses attached, it is capable of being thrown upon an extended screen at a distance. Suppose AA to be screwed on to the front of a magic lantern, or oxy-hydrogen microscope box, instead of the usual nozzle—the light would pass through the two lenses B and C, and be reflected from and polarised at D, which is a bundle of glass plates. Passing along the tube, it is again reflected at G; another bundle of glass plates, previously, however, passing through the lenses under F. Finally it is thrown on to a screen from G. Into the hole E is placed the film of crystal, from which the colors are to be thrown.

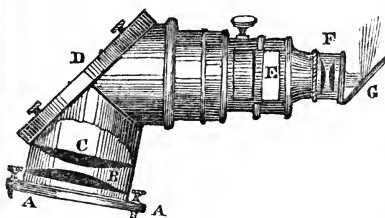

POLARITY. The quality of a thing having poles, or a tendency to turn itself into a certain position, but more particularly used, in reference to the magnet, to an electrical apparatus, to certain modifications of light, &c. (See *Pole* and *Polarisation*.)

POLE. In geography and astronomy, a point at 90° distant from a plane, made by one of the circles of the globe, or opposite to that point in the heavens, as the pole of the equator is 90° distant from every part of the equator, and corresponds to the *poles of the earth*, which are the extremities of that line upon which the earth turns in its daily rotation; that pointing to the north part of the heavens being called the *arctic* or *north pole*; the contrary one having the name of the *antarctic* or *south pole*. The *poles of the ecliptic* are also 90° from every part of this circle, and as the obliquity of it is $23\frac{1}{2}^\circ$ from the equator, its poles will be $23\frac{1}{2}^\circ$ from those of the earth. The *poles of the horizon* are the zenith and the nadir. The *poles of a magnet* are the points of its greatest attraction and repulsion. (See *Magnet*.) The *poles of a galvanic series* are the extreme plates, or the ends of the series, one being called the cathode or negative pole, and the other the anode or positive pole. For pole star, (see *North Star*.)

POLE LATHE. This is the simplest of all lathes; it is adapted only for common work, and such as does not require much strength. Its structure is as follows:—A is supposed to be an elastic pole, about the size and length of the shaft of a chaise. One end

of the pole is fixed to a distant part of the ceiling or a beam. The other end bears a string, as E. This is twisted once or twice round the wood to be turned D, and its lower end fastened to a treadle F. The wood is supported between two pivots, formed by the ends of the screws, which are in the poppets C C. One of these poppets is fixed; the other moveable along the bed, as explained under *Poppet*, (which see.) The rest is not shown, as it differs in no respect from that explained under *Lathe*, except that very often a board is fastened from one poppet to the other, at the proper height, for long work, and upon the upper edge of this, the tools are rested.

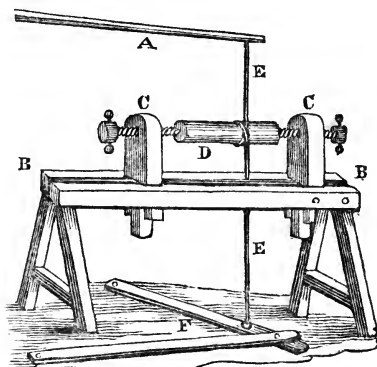

POLE PLATE. A beam of timber placed along a wall, and on the top of the ends of the various tie-beams. (See *Roof*.)

POLESCOPE. A reflective perspective glass, invented by Hevelius, who recommends it as useful in sieges, &c., for discovering what the enemy is doing, while the spectator is hid behind an obstacle. It is, however, more used as a toy, or by lecturers to illustrate the phenomena of reflection. The annexed is a section of the instrument; it consists of a rectangular box, 2 or 3 inches square, bent four times at right angles, and containing at those angles four looking glasses, placed at the angle of 135° with the adjacent sides. Suppose a ray of light to enter at A, it would impinge upon B, and be there reflected to C. At C a second reflection takes place, which passes the light to D. A third reflection carries it to E, and a fourth

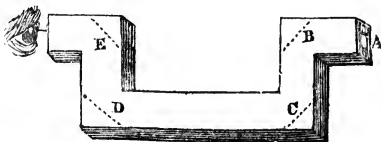

reflection sends it to the eye. It is evident the instrument will act equally well when a solid is interposed between the one arm or extremity and the other.

POLING OF COPPER. The stirring up of the fused copper during its first manufacture with a pole, generally of birch-wood, whereby it acquires considerable tenacity and toughness. The reason of this effect has not been satisfactorily explained, but is supposed to arise from the pole separating from the mass a small portion of the oxyde of copper.

POLINGS. The small boards supporting the earth during the formation of a tunnel.

POLISHER. Synonymous with burnisher.

POLISHING. The art of giving a lustre or gloss to a thing, whether of stone, wood, metal, or other material.

POLLENIN. A peculiar principle found in the pollen of flowers.

POLYACOUSTIC. Any thing that multiplies sound, as a whispering gallery.

POLYCHREST SALT. An old name for a salt, once used in medicine, consisting of a mixture of the sulphate and the sulphite of potass; procured by sprinkling powdered sulphur upon hot nitre.

POLYCHROITE. The coloring matter of saffron.

POLYEDRON. (See *Polyhedron*.)

POLYFOILE. An ornament, like a leaf, of many round lobes. (See *Multifoile*.)

POLYGON. A figure of many sides and angles; if the sides and angles are equal it is called a *regular* polygon. They are distinguished according to the number of their sides, as a pentagon, a hexagon, &c.

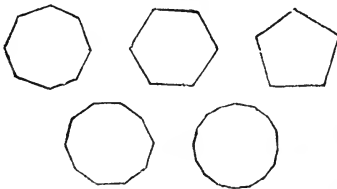

POLYGONOMETRY. The art of measuring polygons, regular and irregular, from a consideration of their angles.

POLYGRAM. In geometry, a figure consisting of many lines; a word now disused.

POLYHEDRON. POLYEDRON. A figure comprehended under many sides; such as the cube, icosaedron, octahedron, &c.

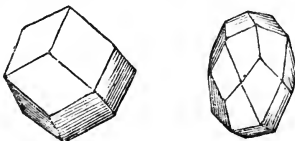

POLYHEDRON, Gnomonical. A stone with several faces, on which are projected many kinds of dials.

POLYNOMIAL. In algebra, a quantity consisting of many terms.

POLYSCOPE. In optics, a multiplying glass, or one which represents a single object to the eye as if there were many. It consists of several plane surfaces disposed under a convex form, through each of which the object is seen.

POLYSTYLE. An edifice with many columns.

POPET, or BACK POPPET. That part of a lathe which holds that end of the work to be turned which is farthest removed from the mandril; or in the pole lathe, which holds both ends of such work. In the common wooden-bedded lathes, the back poppet is very simple. It is represented in fig. 1, below, and consists of a block of wood, cut as represented, with a hand-screw pointed at the end, passing through it at the exact height of the nose of the mandril. It is fixed to its situation by the lower part being cut with a shoulder that rests on the upper face of the bed, and the tenon passing through between the cheeks receives a wedge into a mortice hole made below, which fixes the whole poppet tightly. Fig. 2 shows a poppet on a superior construction. A is a round rod of steel sliding in and out of a shoulder on the top of the iron upright E. To the back of this upright is screwed a frame D, intended for the support of a second socket, which is tapped to receive the screw B. This screw propels the steel rod forward, when required. F is supposed to be a triangular bar, forming the bed of the lathe; and G the screw which fastens the whole poppet firmly to the bed. The screw C is to hold the steel rod when set at its proper distance.

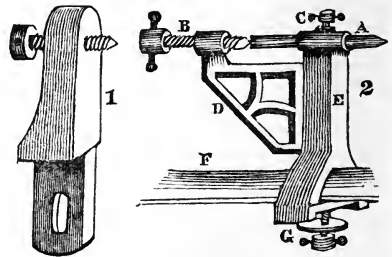

POLYZONAL. Composed of many zones or belts. The term is particularly applied to certain lenses, which are of such large dimensions that they cannot be cast in a single piece; such an one is described under the word *Buffon*.

POMEL. A globular protuberance, or knob, terminating a pinnacle, or similar ornament.

POMPHOLIX. White oxyde of zinc.

PONDERABILITY, is that quality of bodies that relates to sensible weight. Every body in nature possesses ponderability, that is, we are capable of weighing all bodies, except light, heat, and electricity, which are therefore called the three imponderable bodies. Magnetism, being supposed identical with the last of these, is included in it.

PONDERATION. In sculpture, painting, &c., is the proper balancing or supporting a figure or object, so that it shall not have the appearance of instability or tottering.

PONDEROUS SPAR. Any natural combination of barytes, particularly the carbonate and the sulphate.

POPPY HEAD. The top of the boards which form the ends of seats in churches, &c. Some of these made in the middle ages are extremely ornamental.

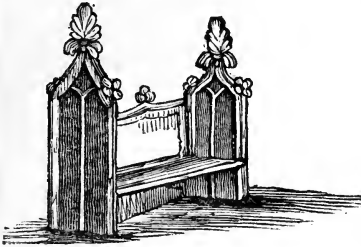

POPPY OIL. An oil much used by the artist, particularly for very light and delicate colors; it not being so apt to turn yellow by age as linseed oil.

POPULIN. A peculiar substance, found in the bark of the poplar, and also several of the willows; called also salicin.

PORCELAIN. A beautiful species of earthenware, which is, at the same time, clear in color, hard, and semi-transparent. From its being once brought principally from China, it is often called by the name of that country. The clay which forms the most necessary ingredient, called *kaolin*, was once only known to be natural to China; but as it is now found in considerable abundance in England, and on the Continent of Europe, porcelain is manufactured in many other places.

PORCH. A vestibule, projecting before the walls of a building, and usually supported by columns or pillars.

PORES. The small interstices between the solid parts of bodies.

PORIME. PORIMA. PORISM. An axiom, or what is self evident; also a geometrical proposition proved with such evident force as to be not merely beyond a cavil, but which may be made a foundation or argument for other geometrical propositions not otherwise easy of solution.

POROSITY. The quality of being porous; a term generally considered as contrary to compactness or density. Porosity is ascertained by the capability of the body to imbibite moisture.

PORPHYRY. A denomination that distinguishes a large class of primitive rocks. There are several kinds, varying in color and degree of hardness. It is used in building, for columns, statues, &c.

PORTAL. The arch over a door or gateway, the frame-work of a gateway, a smaller gate, where there are two of different dimensions, &c.

PORTCRAYON. A pencil case; an instrument serving to inclose a crayon or chalk pencil, and occasionally used as a handle for holding it.

PORTCULLIS. A frame of iron or wooden bars placed over a gateway, to let down as a protection to the gate. It is also often an architectural ornament.

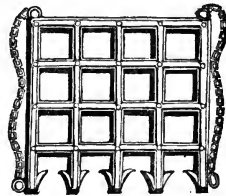

PORTICO. The columns at the end of a building.

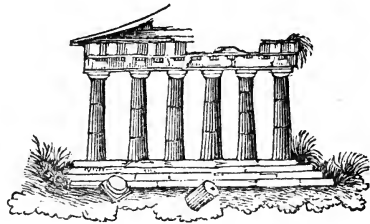

PORTLAND STONE. An alkaline sandstone of a dull, whitish color, heavy, moderately hard, and composed of a large roundish grit. It is one of the numerous varieties of oolite. It is soft when first taken from the quarry, but afterwards acquires considerable hardness. It is much used in building. The greater part of Westminster Bridge is built with it.

PORTRAIT. The delineation of a person's face, &c.

PORTRAIT PAINTING. The art of painting portraits.

POSITION. Situation, or bearing of any thing; used in the mathematics and arts in contra-distinction to magnitude, as the po-

sition of a line, of an object, &c. has no reference to its size or other properties. Position, in astronomy, relates to the sphere or globe, which is either in right, parallel, or oblique position, whence arise inequality of days, the difference of seasons, &c. Position, in arithmetic, is a rule so called, because to procure a correct answer to a question, we suppose a certain number to be the true one, and make this a support for, or a *position* whence to proceed in the required calculation; and as this number is taken at random, it will, most probably, be an erroneous one—hence the rule was formerly called the rule of false. It is divided into single and double position.

POSITIVE. In electricity; (See *Franklin's Hypothesis*.) In algebra, those qualities are called positive which have the sign *plus* + before them, and which therefore indicate that they are to be added to the rest.

POSITIVE AXIS OF REFRACTION. (See *Negative*.)

POST. In building, a large piece of timber, placed upright, either alone, or to support other parts. (See *Roof*.)

POSTICUM. A portico at the back or rear of a temple.

POSTIQUE. An ornament of sculpture is said to be postique, when it is superadded after the work itself is done.

POSTULATE. In geometry, a thing which is granted or allowed to be done without assigning a reason for, or giving an explanation of the manner of doing it. For example, a circle may be made from any centre; a line may be made from one point to another, or may be produced at either end, without explaining how; the method of doing so being self evident.

POTASH, or POTASSA. The protoxyde of potassium. It is called the vegetable alkali from its strongly alkaline properties, and its being inherent in vegetables, from whence it is obtained by burning them, and lixiviating the ashes, and afterwards concentrating the lixivium which contains the alkali, by boiling and leaving it to crystallize. Potash is solid when dry, rapidly deliquesces in a moist atmosphere, is soluble in half its weight of water; soluble also in alcohol. It destroys all animal textures, changes most vegetable blues to green, and the yellow of turmeric to brown.

POTASSIUM. A metallic substance, the base of potash; first procured by Sir H. Davy, by submitting pure potash in small quantities to the action of a powerful galvanic battery, when the potash became decomposed, yielding oxygen to the one pole, and potassium to the other. Potassium is white, of metallic brilliancy, and so soft as to be cut easily with a knife. A grain of it dropped into water, or suspended in a jar of oxygen gas, so rapidly

unites with the oxygen, as to burst into flame, becoming, at the same time, in the one case, the protoxyde; and in the other, the peroxyde of potassium. It melts at 150°, is considerably lighter than water, opaque, and a good conductor of electricity. It combines not merely with oxygen, but with chlorine, iodine, hydrogen, sulphur, and phosphorus.

POTENTIAL CAUTERY. Caustic potash.

POT METAL. A species of stained glass, in which the colors have been incorporated while the glass was in a state of fusion.

POTTERY. The manufacture of all kinds of earthenware, particularly such articles as are common, whether for domestic or manufacturing purposes, as crockery, garden pots, sugar pans, crucibles, &c.; and also Wedgwood, porcelain, biscuit and other ware, of a better description, glazed or unglazed.

POUNCE. Gum sandarac, pounded and sifted very fine; mixed or not with the fine powder of the cuttle fish bone, and used for rubbing on paper, to prevent the writing from sinking or blotting.

POUNXA. Impure borate of soda, as imported from India.

POWDER, Fulminating. (See *Fulminating*.)

POWDER OF ALGAROTH. The white oxyde of antimony, thrown down from the muriate by water.

POWDER OF PROJECTION. (See *Philosopher's Stone*.)

POWDER HOUSE. An electrical apparatus, to show, in an amusing manner, the firing of gunpowder by electricity, and thereby proving the effect of lightning upon buildings in setting them on fire. The house itself is made of seven pieces of mahogany, joined together by hinges, so as to be capable of falling flat on the table; a small projecting ridge along the top of the roof holding it up until the powder is fired. The scientific part of the apparatus is seen by the letters. A is a ball of brass with wire reaching partly down the house, and across it, inside to the brass top of the table C. This has the gunpowder placed upon it. Immediately above the powder is a second ball, which leads by a wire to the outside of the house at the

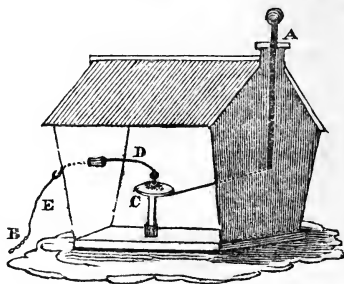

opposite end, passing through the wood at the end of the house. Then follows the wetted thread E, and afterwards the chain B. Passing an electrical shock from A to B, the powder will be fired and the house thrown down.

POWDERINGS. A term sometimes used for devices serving to fill up vacant spaces in carved work, as also in escutcheons, writings, &c.

POWER. In mechanics, is, as Mr. Smeaton defines, the exertion of strength, gravitation, impulse, or pressure, so as to produce motion in what is previously at rest, called therefore a *moving* power; or else to retard the motion of such things as are acted upon by the moving power; this is called the *sustaining* or *restraining* power. For example, in throwing a stone up into the air, the hand is the moving power, and gravitation, by retarding it, is the restraining power. According to the origin of it, it is either animal; natural, as proceeding from water, air, &c., or mechanical, arising from steam, &c.

POWER. In mathematics, is that which arises from the continued multiplication of a number or quantity, and is named according to the number of multiplications; thus 2 standing alone is the first power; $2 \times 2 = 4$ is the square or second power; $2 \times 2 \times 2 = 8$ is the cube or third power; $2 \times 2 \times 2 \times 2 = 16$ is the biquadrate or fourth power of 2; and so on for higher powers. The power is often indicated by a small figure or exponent, attached to the factor, as x, x^2, x^3, x^4 ; and $2, 2^2, 2^3, 2^4$, signify the first, second, third, and fourth powers of x and 2.

POWER. In optics, expresses the effect producible by lenses, or other instruments, as magnifying power, heating power, illuminating power, &c.

PRACTICE. An arithmetical rule, principally employed in ascertaining the value of a number of articles at so much each, being therefore a compendious form of compound multiplication. There are numerous cases or divisions of the rule, according to the amount of the price, whether it be under a penny; more than a penny, and under a shilling; between a shilling and a pound; or consisting of several pounds, and smaller monies. The same rule may be applied to weights and measures.

PRECESSION OF THE EQUINOXES, is a slow retrograde motion of the equinoctial points: viz., from east to west, or contrary to the order of the signs. In consequence of this motion the sun crosses the equator at different points each succeeding year, which points are distant from those of last year about $53\frac{1}{3}''$. Dividing 360° by this it will be found that the sun does not return exactly to the same spot again at the same season until after 25745 years. In con-

sequence of this, the earth's equator is yearly changing its position in reference to the ecliptic, which latter is fixed; or in other words, the equator, and consequently the axis of the earth, is continually altering its inclination to the plane of the earth's orbit, and the pole of the earth will, in the 25745 years before mentioned, make a complete revolution in a circle, the radius of which is equal to the obliquity of the equator, or $23^\circ 28'$: therefore, every part of the equator will, in the course of the above period, represent each equinox, and also represent the solstices, and the seasons will also make a complete revolution in the same period, that which is now mid-winter being in 12872 years hence the height of summer. The cause of the precession of the equinoxes is the attraction of the sun and moon upon the mass of matter which is accumulated around the equatorial regions, rendering the earth an oblate spheroid.

PRECIPITATE. PRECIPITATION. The subsidence or settlement of a powder at the bottom of a fluid in which it has been dissolved or suspended, while the precipitate is the powder so separated.

PRECIPITATE per se, or RED PRECIPITATE. Red oxyde of mercury procured by heat.

PRESS. An instrument for exerting and continuing a pressure upon any article or substance placed within it, for the purpose of smoothing, flattening, drying, embossing, printing from, or diminishing the size of the matter subjected to the pressure. So general a definition includes a vast number of machines, named according to the purposes to which they are applied; thus we have cheese press, wine press, printing press, &c. The principles upon which the whole are constructed are four, as will be seen in the following examples:—

The *lever press* consists of a long lever, bearing upon a strong gudgeon that runs between two uprights. There are holes at different distances along these uprights, that the gudgeon may be shifted according to the thickness of the matter to be pressed. There is a foot-board to the whole, and often wheels; the material being placed under the lever and near the fulcrum, with or without a board on the top of it, is pressed by human

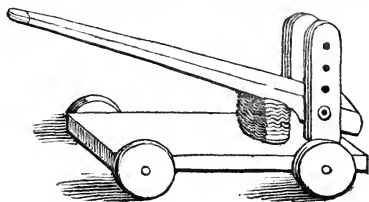

power, or else by a weight suspended from the far end of the lever, which may be of any length. This press is adapted to compress peat, cheese, earth, corks, &c.

The *dead-weight*, or *cheese press*, has an immense block of wood B, or a large box filled with stones, suspended by a screw C.

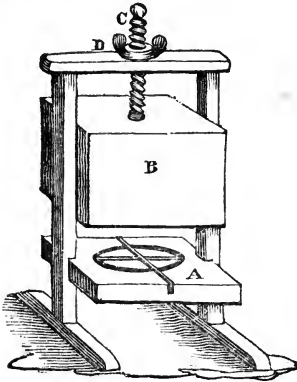

This passes through a hole in the upper bar of the frame, and has a large nut D with handles that rests on this bar. Suppose a cheese or other matter to be placed on the lower board A; upon turning the nut D in the proper direction, the block B would be let down, and removing D entirely away, or to some distance from the bar, the block B would continue to exert a pressure equal to its weight for any length of time; the pressure continuing the same, notwithstanding the shrinking of the substance pressed upon.

The *screw press* is of very different construction; here the power obtained is very great, but if it be required to press a shrink-

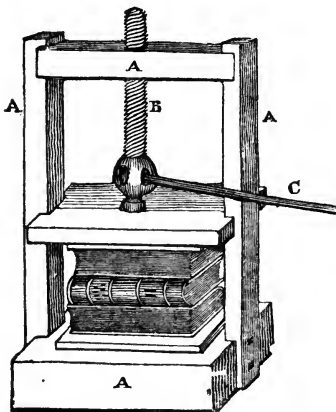

ing substance, the pressure diminishes, and finally ceases altogether, unless attention is paid to work the screw. A A A is a strong frame-work, sometimes of iron, at others of wood, as are also the other parts. B is the screw—it passes through a female screw in the upper board A, and is fastened below, (so however as to have freedom of circular motion) to the upper board of the press. Turning the iron lever C, by means of manual labor, draws up or down the screw B, and of course with it the upper board, thus increasing or diminishing the pressure, as required. This press is often called the *standing press*. (See *Standing Press*.)

The *rolling press* consists of one hard substance rolling upon another, the pressure being exerted upon whatever lies between them, and continuing only while the wheel continues in motion, unless indeed at a single line, should the roller be suffered to rest. The most valuable is, perhaps, the copper-plate press, described under the word *Rolling*. The most familiar examples are the garden and field rollers, the mangle, and the crimping board. There are numerous machines of this nature, also called mills; as the cyder mill, the whitening mill, &c. All these would become presses, were the material acted upon merely smoothed or flattened, rather than crushed.

The *wheel and pinion press*, which is the invention of a Mr. Baird, is an extremely useful press for many purposes, though the power is not very great; yet as it may be continued or not, as required, it is valuable as a wine or cheese press. It is as follows:—

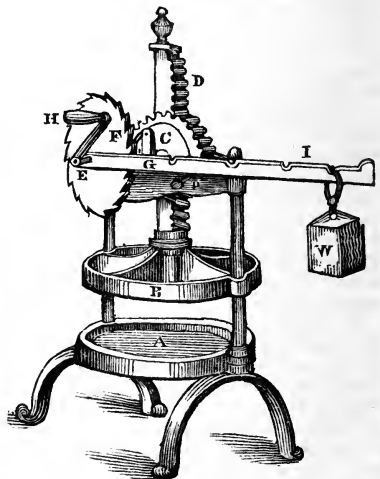

A and B are the bottom and top plates; the lower being fixed—the upper moveable.

There are two ways of moving this upper plate; one quick and easy, until the resistance becomes great; and the other slower, but more powerful, and used for the conclusion of the operation. On the axis of the wheel C there is a pinion of eight teeth, (not seen in the engraving,) which works in the rack D. On the further end of the axis E there is a second pinion of eight teeth, (concealed in the engraving by the other parts,) which acts in the wheel C of twenty-four teeth. This axis E may be turned by the winch handle H; three turns of which will make the rack descend through a space equal to eight of the teeth in the wheel C. In this way the plate B is made to descend at first, but when the pressure becomes great, the lever must be resorted to. This lever I is forked at the end F, and fits loosely on the axis E; one of the forks being on each side of the ratchet wheel F. The upper part of the lever having a pall or click on the top, this catching the teeth of the wheel F turns it round a certain portion; according as the lever is worked, a second pall or click behind F keeping it from returning when a second stroke is made with the lever. If it be desired to continue the first given degree of pressure, the lever I is raised considerably above the horizontal position, and a weight W attached to it; as the material below shrinks, the lever descends until stopped by the pin, which is inserted in the frame-work, or lower than this if the pin be taken out. For other presses, (see *Bramah*, *Copying*, *Hunter*, *Lithographic*, *Printing*, *Ruthven*, *Stanhope*, *Straker*, &c.)

PRESS, *Hydrostatic*. (See *Bramah*.)

PRESSURE. Weight, or a continued power or exertion of force.

PRIMATIVE COLORS. The same as prismatic colors. These, although formerly considered as seven in number, are more properly restricted to three; namely, red, yellow, and blue, from the mixtures and combinations of which all the other colors, tints, and gradations, are composed; white being a combination of all these, and black a total deprivation of color. This, although true in nature, is not true in art. In solar light there are three primitive colors, as above stated. The mixture of the red and yellow producing orange; of the yellow and blue, green; of the blue and red, a purple or violet; and these of various degrees of tint, according to the proportion of one or other of the colors. But there are numerous tints to which other colors must be added to produce them artificially; thus red and black constitutes brown; black and green, or brown and green, an olive; brown and red, a chocolate; a white is no less necessary to produce salmon color, pink or flesh color, straw color, stone color, &c.

PRIMATIVE FORM OF CRYSTALS. When crystals are split in their cleavage planes as much as possible, and then their angles examined by the goniometer, they will be found to present one or other of the regular bodies, which are called their primitive forms. They are the cube, the tetrahedron, the octaedron, the hexangular prism, the rhombic dodecahedron, and the dodecahedron, with isosceles triangular faces.

PRIME FIGURE. In geometry, one that cannot be divided into any other figures more simple than itself. Such are a triangle and a pyramid.

PRIME NUMBERS. Those which cannot be divided into equal integral parts, less than the numbers of units of which they are composed. Such are 2, 3, 5, 7, 11, 13, 17, 19, 23, &c.

PRIME VERTICAL, is that vertical circle or azimuth, which is perpendicular to the meridian, and passes through the east and west of the horizon.

PRIME VERTICAL DIALS, are those which are projected on the plane of the prime vertical circle, or in a plane parallel to it. These are likewise called direct, erect, north and south dials, &c.

PRIME OF THE MOON, is the new moon at her first appearance, until about three days old. It also means the golden number.

PRIMUM MOBILE. (See *Ptolemy*.)

PRIMING. Among painters, the laying on of the first color. Priming, in engineering, is the name given to the hot water which is carried along with the steam into the cylinder of the steam engine.

PRINCE RUPERT'S DROPS. Drops of green glass, suddenly cooled by letting them fall into water. As soon as the small end is broken off, they immediately fall into dust, with an explosion. The exact cause of this has never been satisfactorily explained.

PRINCE'S METAL, or **PRINCE RUPERT'S METAL**. An alloy of 3 ounces of copper to 1 of zinc.

PRINCIPAL. The chief object proposed, delineated, or constructed, and to which all the other parts are subservient. Principal, in arithmetic, any sum of money lent on interest, either simple or compound.

PRINCIPLE OF D'ALEMBERT. (See *D'Alembert*.)

PRINCIPLE OF VIRTUAL VELOCITIES. When a system of material points, elicited by any force, is in equilibrium, if the system receive a small alteration in its position, by virtue of which every point describes an infinitely small space; the sum of each force multiplied by the space described by the point to which it is applied, according to the direction of the force is always equal to zero. This is called the general principle of virtual velocities.

PRINTING. The art of taking copies by impression of type, drawings on stone, engraved blocks, plates, or rollers, in inks, pigments, dyes, &c. Thus we have letter-press printing, calico or roller printing, paper staining or printing, copper-plate printing, lithography, and many other styles; but the word printing, standing alone, without any distinctive addition, is usually understood to imply typography, or printing from type, commonly called letter-press printing. In the other kinds of printing, the preparer of the plates, rollers, blocks, &c., is mostly a different person from him who really prints from them, yet in the letter-press work the same tradesman conducts the whole process, and which may be briefly described as follows!—The type is received from the type-founder, and distributed in cases, where each letter has a separate box for itself; those most wanted being nearest the hand. The compositor taking a composing stick in his left hand, first sets it to the requisite measure or width. He then picks up the required letters from the cases, one by one, and arranges them in order, until he has one line complete, adding during his progress spaces between the letters, and such others afterwards as exactly fill up the line; another, and afterwards a third, fourth, and fifth line is proceeded with in the same manner. The lines thus set up are then placed on a board, called a *galley*. When sufficient progress has been made, the quantity requisite for a page is tied up with a thin twine, and when a sufficient number of pages are thus complete, they are put in proper positions with each other on a flat stone; a *chase* or iron frame is put over them—long pieces of wood, called *furniture*, are put around each page, and wedges, called *quoins*, are driven tightly, at various places around, to keep the whole in their places. The chase with the pages in it is called a *form*. It is taken to the press, properly adjusted, inked by dabbing it with an inking ball or roller, and the paper being placed upon it, the press is pulled down, and an impression taken. The whole number of prints being taken off, the form is washed with potash lye, to cleanse it of superfluous ink; it is *unlocked* or *unfastened*, and the type by little and little *distributed*, or placed in the cases, as at first, ready for other work.

PRINTING APPARATUS. For other apparatus belonging to the art of printing, (see *Ball, Composing Stick, Inking Table, &c.*)

PRINTING INK. The ink used by the printer. It is of two kinds; one used by the copper-plate printer and the other by the type printer—each kind being made of various colors. Copper-plate ink is mostly made extemporaneously by the printer, of Frankfort black, mixed with drying linseed oil, or linseed oil boiled until it is quite thick and

brown. Lithographic printing ink differs in no respect from the preceding, except in being used of different degrees of thickness, according to the work to be executed. For a fine ink, adapted to letter-press work, Mr. Savage gives the following receipt:—Balsam of capivi, 9 oz.; lamp black, 3 oz.; indigo and Prussian blue, together, 1½ oz.; Indian red, ¾ oz.; dry yellow soap, 3 oz.

PRINTING PRESS. An instrument used to produce impressions from properly-arranged types, engraved plates, or painted stones, called according to the use to be made of them respectively, the *letter-press*; the *rolling press*, or the *copper-plate press*; and the *lithographic press*. The two last are described under the words *Rolling and Lithographic*. The first is alone referred to in the following explanations:—All the presses used by the letter-press printer, except that called the Ruthven press, are acted upon by manual power applied at the end of a lever, by a stroke similar to that of rowing. The power is continued to the surface of the type, where it is alone required, by means of other levers connected with the first lever or handle. The *wooden press* is the most ancient, being that used by the first printers, and no alteration having been made in it till a very recent period; and though far inferior to the modern iron presses, yet, as it is much cheaper, the wooden press is still much used in country and small offices. The annexed cut shows its form and principle.

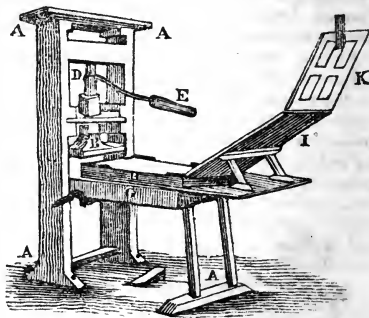

The frame-work A A A is made strongly of wood, and fastened to the floor. B is called the *platten*—it is a square block of mahogany or other hard wood, hung by four small hooks to what is called the *hose*, which is a square trunk in which the *spindle* D fits. This spindle is made conical at the lower end, so that when pressed down, it presses down at the same time the hose and the platten, and when drawn up, it is prevented from leaving the hose by a pin or a strap, called the *garter*, which fits into a groove cut round the spindle; thus the spindle may

turn round, yet not be drawn out without removing the garter. The spindle has on the upper part of it a screw which fits into a contrary screw cut in the cross bar of wood immediately above it, which is called the *head* of the press. The lower part of the press consists of the frame-work, called the *carriage*, G. The part marked H is called the *bed*. It consists of a large and very flat stone, imbedded in a frame called the *coffin*, made of wood, and strengthened with *clamps* of iron at the corners. This may be run under or away from the platten by means of a strap fastened at each end, and passing around a roller beneath the carriage, which is worked by a handle at the side. I is called the *tympan*—it consists of two frames covered with parchment, and with two or more folds of flannel between them; this is fastened to the coffin by pivot joints, or by hinges, and rests upon a frame called the *gallows*. K is the *frisket*, which is a light iron frame, mostly with strings across it to hold the paper steady, and paper fastened on it to keep the margins, &c. clean. The pressman having damped paper at the side of him, on a table, called a *bank*, and having placed the form of type on the stone, inks the type, takes a sheet of paper, places it carefully on the tympan, turns down the frisket over it, then turns both down upon the face of the type, rolls the coffin under the platten, pulls the handle once or twice, runs the coffin out again, and turning up the tympan and frisket, finds the sheet of paper printed. The chief iron presses now in use, are the Stanhope, the Ruthven, (see *Stanhope* and *Ruthven*,) the Columbian, the Imperial, and the Albion.

The *Columbian printing press* is considered more powerful than any other. It was the invention of Mr. Clymer, a North American, in 1817. The whole of the press is of solid iron. The under surface of the platten and

upper surface of the table are turned truly flat in a lathe. The tympan has a counterpoise weight attached to the lower end, to assist in lifting it up. The carriage consists of two ribs, as is seen more clearly in the Albion press. The leverage to produce the pull is of the greatest power. It consists of four levers acting upon each other, not merely pressing down the platten, but lifting up the counterpoise lever, (that which bears the eagle.) This falling down again, draws the platten up and the handle back, ready for the next pull.

The *Albion press* is another most valuable instrument; it is lighter and neater, more easy to work, and of a power nearly, if not quite equal, to that of the Columbian. It is the invention of Mr. Cope, of London, but has been greatly improved by Mr. Hopkinson. It consists of feet, staple, and other parts constituting the frame-work; platten, table, tympan, &c. Its power is a very simple combination of levers, which are mostly inclosed in the head of the press. The platten rises in consequence of a spring being contained in the box at the top, which is connected with the top of the spindle.

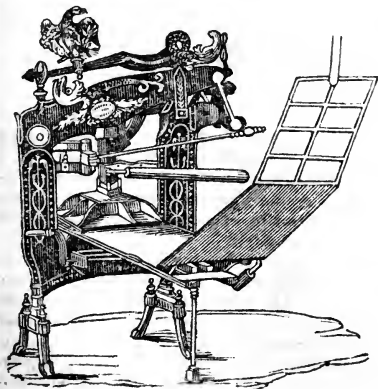
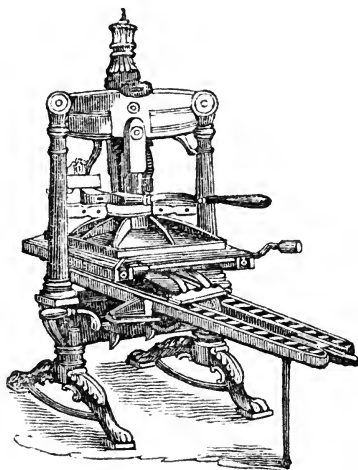

PRINTER'S TYPES, Metal for. Melt together 10 lbs. of lead and 2 of antimony. Each founder, however, has his own receipt. The following is recommended for small type:—Melt 9 lbs. of lead, and when melted add 2 lbs. of antimony and 1 lb. of bismuth.

PRISM. A geometrical figure or solid, whose two ends are parallel, equal, and straight, and whose sides are rectangles joining these. Hence every section parallel to the base is equal and similar to the base. Prisms receive particular names, according to the figure of their bases; as a *triangular prism*; a

square prism; an hexagonal prism; and so on. Also a prism may be either regular or irregular, according as its ends are regular or irregular polygons.

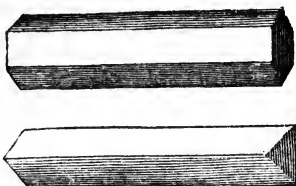

PRISM. In optics, is an instrument employed for showing the properties of solar light; and consists merely of a triangular prism of glass, which separates the rays of light in their passage through it, in consequence of the different degrees of refrangibility that has place in the component part of the same ray. It is by means of this instrument, that the origin of colors is shown to be owing to the decomposition which takes place in the rays of light; each ray consisting of innumerable rays of different colors. Thus a sunbeam being let into a darkened room, through a small round aperture A, and falling upon a glass triangular prism P, is by the refraction of the prism considerably dilated, and will exhibit on the opposite wall an oblong image C D, called a spectrum, various colored; the extremities of which are bounded by semi-circles, and whose sides are straight. The colors are commonly represented as seven in number, which however have various shades, gradually intermixing at their juncture. Their order is as represented in the cut; violet, indigo, blue, green, yellow, orange, and red. The obvious conclusion from this experiment is, that the several component parts of solar light have different degrees of refrangibility, and that each subsequent ray in the order above mentioned is less refrangible than those which precede it; the violet being the most refrangible, and the red the least.

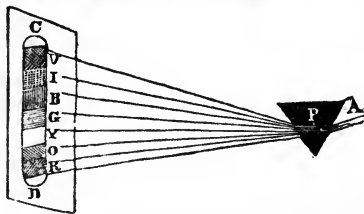

PRISMATIC COLORS. The colors into which a ray of light is decomposed, when refracted from a prism, as before explained. Newton considered these as seven in number. (See *Primitive Colors.*) The proportion which

these colors bear to each other in a ray of light, are violet 80, indigo 48, blue 60, green 60, yellow 40, orange 27, red 45; and if a large card have its rim painted of these colors in the above proportion, and then be made to revolve rapidly, the seven colors will become so blended as to give the appearance of *whiteness*, just the same as these colors, in like proportions, constitute in nature a white light.

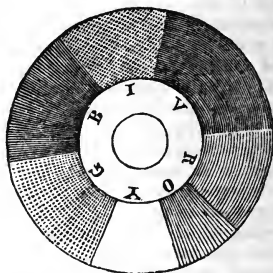

PRISMATIC SPECTRUM. (See *Prism in Optics.*)

PRISMOID. A solid, similar in form to a prism.

PROBLEM. In geometry, a proposition in which something is required to be done, and which is afterwards to be proved to be the thing required. A problem consists of three parts—the proposition or thing proposed to be accomplished; the resolution or solution, which is the method of performing the thing required; and the demonstration or proof of the correctness of the operation.

PROBLEM OF THE THREE BODIES, is the term by which is denoted the celebrated problem of finding the inequalities of the lunar orbit. The problem is as follows:—Three bodies of given magnitudes, as the sun, the earth, and the moon, being projected into space with given velocities, and in given directions, and attracting each other according to a given law, (the inverse ratio of the square of their distances from each other, and directly as their masses,) it is required to determine the nature of the curve, that one of them as the moon, describes about one of the others as the earth. This is a problem which has engaged the attention of the most celebrated analysts of modern times.

PRODUCING. In geometry, the continuing a straight line, or drawing it out to any assigned length.

PRODUCT. In arithmetic and algebra, is the quantity arising from the multiplication of two or more factors, as 24 is the product of 6 and 4, or the number produced by the multiplication of 6 and 4.

PROFILE. The outside or contour of any thing, such as a figure, building, ornament, &c.

PROFILE INSTRUMENT. (See *Silhouette*.)

PROGRESSION. In arithmetic and algebra, a series of numbers advancing or proceeding in the same manner, or according to a certain ratio. It is either arithmetical or geometrical. Arithmetical progression is when the numbers proceed by some common difference, as 1, 3, 5, 7, 9, &c. In geometrical progression, the series of numbers increase or decrease by a common ratio, as 1, 2, 4, 8, 16, and so on, the constant ratio in this case being 2.

PROJECTILES, is that branch of mechanics which relates to the motion, velocity, range, &c. of a heavy body projected into void space, practically speaking, into the air, by any external force, and then left to the free action of gravity, by which it descends to the earth, such as a ball fired from a cannon, the flight of an arrow, rocket, &c. A projectile is always acted upon by two forces; the propelling force, which carries it along, and which is always decreasing; and the power of gravitation, which draws it downwards, and which is an accelerating force. These two forces acting upon a projectile, which moves perpendicularly, will merely counteract each other after a short time, when the body projected will have attained its highest point, after which it will fall, being influenced by gravitation alone; or if projected horizontally or obliquely to the earth's surface, the combined forces will occasion its path to be that of a parabola.

PROJECTION. The art of forming the representation of a body upon a plain surface; also any thing which appears similar to such a drawing. Thus we say the projection of an estate, or the plotting of it; also the projection of a shadow, though caused naturally. Projection or projecture, is also any thing projecting beyond a general flat surface; thus prominent mouldings, cornices, &c. are projectures from a building. Workmen often call them sailings over.

PROJECTION, Powder of. (See *Philosopher's Stone*.)

PROLATE. An epithet applied to a spheroidal body which turns on its longer axis, or which resembles the figure made by revolving a semi-ellipse on its conjugate diameter. A lemon is a prolate spheroid.

PRONAOS. A vestibule; the space under a portico, a porch, &c.

PROOF. In engraving, a print taken off in the course of the engraver's process, that he may ascertain how far his labors have been successful. In copper-plate printing, proofs are the earliest and most careful prints taken from an engraved plate. In letter-press printing, a proof is a rough print taken as soon as the type is arranged, in order to enable the printer to correct errors, and the author to re-examine his

work before it is finally printed off. Proof spirit signifies any spirituous liquor which is of a certain strength. (See *Hydrometer*.)

PROOFS. (See *Bologna Phials*.)

PROPORTION. The just relative magnitude of the parts of an object or of a scene to each other. Thus the different members of a building, machine, statue, drawing, &c., may or may not be in just proportion.

PROPORTION. In mathematics, signifies an equality or similarity of ratio; that is, if the ratio of 6 to 3 be the same as that of 24 to 12; then 6, 3, 24, and 12, are in proportion, which is denoted by placing the quantities thus, 6 : 3 :: 24 : 12, and is read, as 6 is to 3, so is 24 to 12. This, because three of the numbers are usually given to find a fourth, is often called the rule of three, and is divided into *direct* and *inverse*. In direct proportion, the second term, if greater or less than the first, requires the fourth to be in like manner greater or less than the third, as in the above example. In inverse proportion, the fourth term does not agree with the second, in being greater or less than that which precedes it, but is reversed; thus, if the second be greater than the first; the fourth will be less than the second, and so on. (For other kinds of proportion or progression, see *Arithmetical*, *Geometrical*, and *Harmonical*.)

PROPORTION, Compass of. A name by which the French and some English authors call the sector.

PROPORTION, Definite. (See *Atomic Weights*.)

PROPORTION, Rule of. The rule of three.

PROPORTIONAL. Relating to the proportion which objects, quantities, and numbers bear to each other, as proportional parts, scales, &c.

PROPORTIONAL CIRCLES. (See *Pitch Lines*.)

PROPORTIONAL COMPASSES. (See *Compasses*.)

PROPOSITION. In mathematics, is either some truth advanced, which is to be demonstrated, or some operation proposed, which is to be performed, and shown to be that which was required. Being in the former case called a theorem; in the latter a problem. (See these terms.)

PROPYLÆUM. A court or vestibule before a building. The word is now chiefly applied to the building forming the entrance to the Acropolis of Athens, which is called "The Propylæa," without any other designation.

PROSTYLE. A temple having columns in front only.

PROT, or PROTO. In chemistry, signifies a combination, in which the base is in the largest proportion to the combining substance. Thus a protoxyde contains a less proportional quantity of oxygen than a deutoxyde or a

peroxyde; a protochloride proportionably less chlorine; and so on.

PROTRACTOR. A scale for the purpose of measuring or laying out angles on paper. It is one of the instruments ordinarily belonging to a case of mathematical instruments, and consists of a semi-circular arc of brass, with a straight edge joining the two ends of the semi-circle. This latter is graduated from each end; so that when it is required to lay down an angle of a certain measurement, the protractor is laid upon the paper in such a way, that the centre of the straight limb exactly coincides with the angular point, and the edge with one of the lines of the angle; a point being made with the pencil, adjoining to the circular arc, and at the required degree, shows where the second line of the angle is to come.

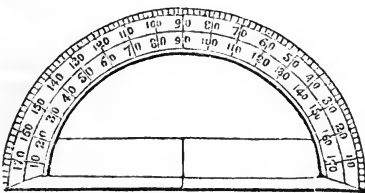

PRUSSIAN ALKALI. Ferro-prussic or ferro-cyanic acid.

PRUSSIAN BLUE. The prussianate of iron. Heat to redness dried blood or other animal matter, with an equal weight of pearl-ash, till reduced to a paste; dissolve the residue in water, filter and mix with a solution of 1 part of proto-sulphate of iron and 2 parts of alum; the greenish precipitate absorbs oxygen from the atmosphere, and it is thence tinged to the proper color.

PRUSSIAN GREEN. A celebrated pigment, consisting of an imperfect Prussian blue, containing excess of the oxyde of iron, to which the yellow tincture of French berries is added.

PRUSSIATE. Any salt of the prussic acid.

PRUSSIC ACID, or HYDRO-CYANIC ACID, is a compound of hydrogen and cyanogen. It is a clear, limpid liquid, of a strong pungent odour, very like that of bitter almonds, in which, as well as in other species of stone fruit, it is found. Its taste is acrid, and it is highly poisonous, so that the utmost care should be taken to avoid inhaling its vapour. It volatilises so rapidly as to freeze itself when a drop of it is placed on a glass plate. It feebly reddens litmus. It is decomposed by many of the metallic oxydes, and water and a metallic cyanuret are the result.

PRUSSINE, or PRUSSIC GAS. (See *Cyanogen Prussic Acid.*)

PRUSSO-DIPTERA. A temple with two

rows of columns in front, and with a single row of columns all round the other part.

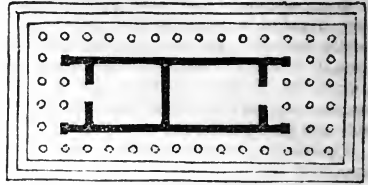

PTOLEMAIC SYSTEM OF ASTRONOMY. Ptolemy, the celebrated astronomer, believed and taught that the universe was thus constituted:—That our earth was the centre of the whole. That there revolved about the earth—first, the moon, then the sun; more distant, in regular rotation, Mercury, Venus, Mars, Jupiter, and Saturn; outside of which planet were the starry heavens, and beyond this three different strata, or hollow spheres within each other, called the first, second, and third crystalline heavens, and to bound them was the *Primum Mobile*, or Great First Cause.

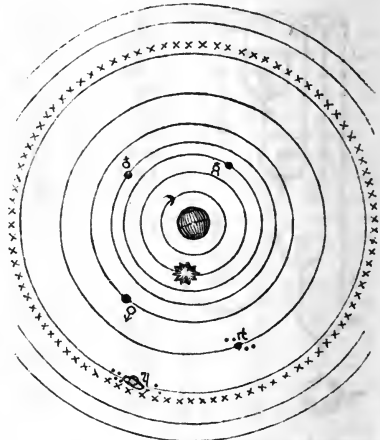

PUDDLE. A mixture of good tempered clay and sand reduced to a semi-fluid state, and well combined. It is used for the purpose of retaining the water in any particular situation, or for excluding it from any works, and is usually spread in layers of about 12 inches in thickness.

PUDDLING. A curious process by which cast iron is made into wrought iron. Cast iron, after it has been in some degree refined by fusion, in contact with charcoal, is put into a reverberatory furnace, and when in fusion, is stirred, so that every part may be exposed to the air and flame. After a

time, the mass heaves, emits a blue flame, and gradually grows tough, becoming less fusible, and at length pulverulent; the fire is then urged so that the particles again agglutinate at a welding heat, and are gradually wrought up into masses. In that state of immense heat the masses are passed successively between rollers, by which a large quantity of extraneous matter is squeezed out, and the iron becomes malleable.

PUGGING. A coarse kind of mortar laid upon the boarding between joists, in order to prevent sound reaching from one apartment to another. Filling up the intervals in flooring, &c. with the refuse cuttings of cork is far superior to deaden sound, though more dangerous in case of fire.

PULLEY. One of the mechanical powers. It consists of a small wheel with a groove round it, and turning on an axis, and hence by means of a rope it is employed to raise weights or to draw them in any direction. The moveable wheel is called the *shieve* or *sheave*. The axis is the *gudgeon*, and the fixed piece of wood or brass in which the sheave is placed is the *block*. By a simple or single pulley, as fig. 1, in the cut, no

to sustain the weight *W* of 16 lbs.; *O* has to bear 8 lbs.; *B* only 4 lbs.; the pulley above 2 lbs.; and the cord above dividing this, the weight *X* is but 1 lb., and yet it supports 16 lbs. at the other end, not allowing, however, for the weight of the various pulleys, which is very trifling. In all systems of pulleys, the weight is divided, or what is the same thing, the power is increased in the same geometrical ratio for every moveable pulley, whatever be the general form of the whole system or arrangement. Thus in figs. 2 and 3, as there are two moveable pulleys to each, the power applied at one end is increased four-fold at the other; that is, a man pulling at the cord can raise four times his own weight, or the power he chooses to employ. Fig. 2 is usually called a tackle, and is the form most commonly employed.

PULLEY, Live and Dead, or Fast and Loose. Two pulleys placed close together, and attached to a crane, lathe, mandril, or other machinery, to carry the band which turns it. The band slipped on to the dead or fixed pulley, turns the machinery; slipped on to the live or moveable pulley, that alone moves round while the machinery rests. It is represented below, the pulley *B* being immovably fixed to the shaft *C*, and the pulley *A* turning round upon the axis.

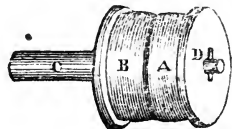
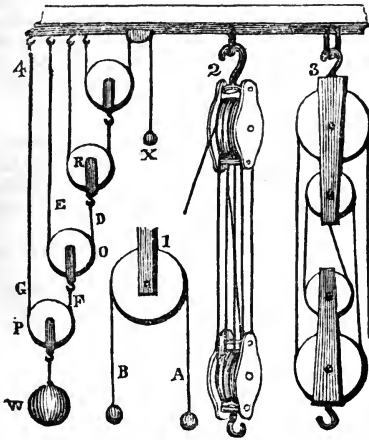

PULLEY, Sliding. A means of coupling and disengaging machinery, as follows:— *A* is the axis or shaft. *P* is a pulley, fixed to a hollow cylindrical bush, made so that it can revolve easily upon the axle, and slide backwards and forwards upon it. *B* a part of the bush projecting on one side of the pulley, having a groove sufficiently large to admit the lever *I* to lay in it without impeding its motion. *C G* is a cross or gland

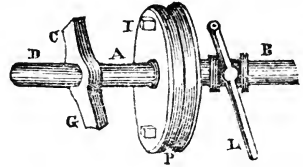

power is gained. *A* and *B* is the cord which passes off it, being equally balanced by an equal weight. It is valuable only in altering the direction of motion; but if inverted like the pulley *P*, in fig. 4, so that one end of the line is fixed above, the fixed side of the line *G* will bear half its weight, and the other side of the line will support the other half, *F*. Instead of fastening *F* to a second hook at top, let it be attached to a second pulley *O*. Here the weight is again divided, one half being borne by *F*, the other by *D*. A third pulley *B* will halve it again, and a fourth pulley, in like manner, halve the weight of *B*. Thus supposing the pulley *P*

fixed firm to the axle; and *I* one or more teeth projecting from the face of the pulley. When the axle *A D* is to be put in motion, the lever *I* must be moved towards the cross or gland *C G*, so that the teeth upon the pulley may catch hold of and carry it round with it.

PULSE GLASS. A little instrument to show the effects of heat. It consists of a small glass tube, with a bulb at each end, and partly filled with colored spirits of wine, the space above the spirit being void of air. When this tube is held in the hand obliquely, a small bubble of air remaining in the lower ball, the heat of the hand will expand the air in this bubble, and its escaping into the vacant space above with a pulsatory motion, occasions the instrument to be called a pulse glass, though it has no reference to the state of the pulse.



If the glass be made in the shape of the following tube, the liquid will appear to boil rather than rise in pulsations:—



PULVINATED, or PILLOWED. The swelling of the frieze in the Ionic order.

PUMICE STONE. A porous substance, procured from the volcanic countries, and generally considered as the result of volcanic eruptions. It is used in this country chiefly as a polishing powder, when ground, or as a material to smooth the surface of painted work, &c.; used in a lump.

PUMP. A machine for raising fluids by means of pistons or buckets, working in tubes; valves also being placed within them. The principal and most useful pumps are the *lift pump*, the *force pump*, the *common or suction pump*, and the *air pump*; each of which is described under its distinctive name. The following is a pump but little known, and yet very simple in structure, great in power, not liable to get out of order, and which may be made by any ordinary workman:—A B C D is a square trunk of wood, with a partition across it, near the bottom; a hole being in the partition, covered with a valve, opening upwards, E. Above the valve, and surrounding it is a bag of canvas, sewed and turred so as to be water tight; hoops placed around it at intervals prevent bursting when the bag is filled with water. The upper end of the bag is tied tightly to a round board, also with a hole in it, and covered by a valve F. To this is fastened the piston rod G. Pulling up the rod,

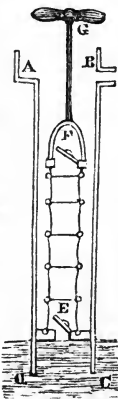

and thus elevating the bag, opens the lower valve, and shuts the upper one. The water, therefore, from the well rushes up to fill the vacuum formed; when the piston rod is depressed, the lower valve closes, and the return of the water is prevented, while the water already in the bag flows out through F. The next stroke of the pump handle lifts a fresh supply of water, and discharges the former quantity. (See *Force, Lift, Suction, Ctesibius, De la Hire, Spiral, Concentric, Chain, Bucket, Air, &c.*)

PUNCH, PUNCHEON, or PUNCHION. A little bar of steel, plain at the end, or impressed with some letter, figure, or device, which is impressed upon a substance by striking the opposite end of the punchion with a hammer. Instruments of this kind are extremely common in all the arts. Punccheon is also the general name for most of the instruments used by stone-cutters, sculptors, locksmiths, &c., for the making holes in, or cutting their various matters. An upright arbor in machinery is frequently called a puncheon.

PURBECK STONE. A hard conglomerate, of an ashy grey color, which very frequently contains nodules of flint or other crystalline substance. The starlings of Old London Bridge were of Purbeck stone. The harder kinds, for there is much difference in this respect, take a fine polish, and are usually called Purbeck marbles.

PURPLED. Richly sculptured.

PURLINS. The horizontal pieces of timber lying on the main rafters, to support the common rafters in the middle of their length.

PURPLE POWDER OF CASSIUS. (See *Cassius.*)

PURPURATES. Compounds of the purpuric acid.

PURPURIC ACID. An acid obtained by treating uric or lithic acid with dilute nitric acid. It has a fine purple color, but has hitherto been applied to no use in the arts.

PURPURINE. The name of a coloring matter supposed to exist in madder.

PURSUIT, Curve of, is one generated by the motion of a point, which is always directed towards another point. also in motion, along a straight line; the velocity of the two points bearing any determinate ration to each other.



Thus let A and B be two bodies; the one B moving along the line B E, with any given velocity, and the other A moving with another

given velocity, and in such a manner as to be always directed towards the body A B ; then is the curve A E, thus described by A, the curve of chase, or the curve of pursuit.

PUTLOG HOLES. The small holes left in a wall, for the use of the workmen in erecting their scaffolding; the cross pieces of wood which support the boards of a scaffold being called putlogs.

PUTREFACTION. The spontaneous decomposition of such animal or vegetable matters, as exhale a fetid smell. The solid and fluid matters are resolved into gaseous compounds and vapors, which escape, and into an earthy residuum.

PUTREFACTIVE FERMENTATION. (See *Fermentation.*)

PUTTY. A kind of paste, compounded of whiting and linseed oil, with or without white lead. It is used by glaziers, for fastening the panes of glass into their frames, and stopping holes in wood-work previous to painting it.

PUTTY POWDER. Oxyde of tin; used as a polishing powder in many of the arts.

PUZZOLANA. A substance formed of volcanic ashes, more or less compacted together. When mixed with a small portion of lime, and water is added, it forms a mortar, which becomes extremely hard under the surface of water, consequently puzzolana is valuable for the foundation of light-houses and other marine erections.

PYCNOSTYLE. A term when columns are arranged at only a diameter and a half from each other.

PYRAMID, Electrical. An apparatus in electricity, showing the effect of interrupted

conductors, in occasioning destruction to buildings, instead of protecting them from lightning. It is of two parts, A and B. B is a square base, which is fixed; it has a square hole in the front, a quarter of an inch deep, and one inch on each side; to this hole is fitted a piece of wood D, so slightly, however, that a mere trifle will remove it. A wire is let in across the wood; a wire also runs down the front of A, and partly the front of B, where it terminates by a hook C. The wood being placed one way, the wire is continuous; in another way, that is transversely, the wire is interrupted. The pyramid A rests on three brass balls; the ball in the front resting upon the moveable piece of wood. If a shock be passed from the chain E, through the wire C, the wood D, and second chain F, provided the wire be

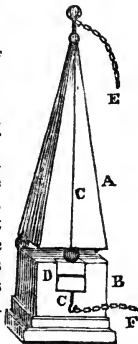

continuous all the way down, no effect will take place, but if the wire of D be transverse, and therefore not connected with the wire C the piece of wood D will be thrown out, and the pyramid A immediately fall.

PYRAMID. In geometry, is a solid having any plane figure for its base, and triangles for its sides, all terminating in one common point. If the base of the pyramid is a regular figure, the solid is called a regular pyramid, which then takes particular names, according to the number of its sides, as triangular, square, pentangular, &c.

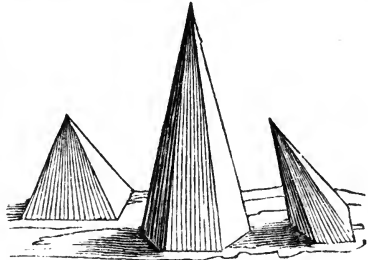

PYRAMID OPTIC. (See *Optic.*)

PYRAMIDOID. A figure resembling a pyramid.

PYRITES. Native compounds of metals with sulphur; as iron pyrites, copper pyrites, &c.

PYROACETIC ETHER. Pyroacetic spirit; acetone. (See *Acetone.*)

PYROCITRIC ACID. When citric acid is distilled in a retort alone, an acid liquid is obtained, which, when saturated by lime, affords a precipitate, that can be decomposed by oxalic acid, and thus furnishes a peculiar product, called, by Lassaigne, pyrocitric acid. It forms salts, perfectly distinct from the citrates.

PYROELECTRICITY. (See *Thermo-Electricity.*)

PYROGALLIC ACID. An acid produced by the action of heat upon gallic acid; the heat by which it is distilled being from 410° to 420°. If the heat exceeds this, another product called the metagallic acid is obtained. It is in the form of brilliant white crystals, very soluble in water, alcohol, and ether; and slightly reddening litmus.

PYROLIGNEOUS ACID. A vinegar produced by the destructive distillation of wood, particularly of birch and beech. The wood is placed in retorts, similar to those used in the gas works, and the retorts being heated, the acid passes off by a pipe connected with the retorts, and passing through a worm or refrigerator is cooled, and collected in a vessel beneath. The retort holds about 8 cwt. of wood, which yields about 35 gallons of crude or impure acid; the weight of this is 300 lbs.

It is rectified by a second distillation. It is used as a household vinegar, and for numerous other purposes.

PYROMECONIC ACID. This acid is among the products of the destructive distillation of the meconic acid. It is a crystalline substance, volatile, soluble in water and alcohol, and forms many soluble salts.

PYROMETER. An instrument for measuring the expansion of bodies by heat. It differs in no respect from the thermometer, except that it is applied more particularly to measure such high degrees of heat as the thermometer cannot ascertain, particularly the heat of furnaces. Thermometers mostly act by the expansion of liquids, occasioned by a moderate heat; pyroscopes by the expansion of air; and pyrometers by the expansion of metallic substances. Equal additions of heat, at all times, and in all of them producing equal expansions, with the single exception of water, under certain circumstances. There are numerous pyrometers, described under the names of their inventors, *Froteringham, Ferguson, Regnier, Morveau, Crighton, Breguet, Houriet, Wedgewood, &c.*

PYROMUCIC ACID. An acid procured from the destructive distillation of the mucic acid. It is permanent in the air, inodorous, very sour, fusible at 270° , crystallises in needles in the ordinary state of the atmosphere, soluble in 26 parts of cold, less of hot water, and still less of alcohol.

PYROPHORIC ANTIMONY. It is tartrate of antimony and potass, or emetic tartar, heated to redness, and out of contact with the air.

PYROPHORIC LEAD. The tartrate of lead mixed with charcoal, and exposed to a red heat in close vessels; it takes fire when brought into contact with the air.

PYROPHORUS. An artificial compound that takes fire or becomes ignited on exposure to the air. It is prepared from alum, with the addition of various inflammable substances. It may be made thus:—Mix 3 parts of alum with 1 of wheat flour, and calcine them in a common phial till the blue flame, which will arise, disappears. Keep it in the same phial, well stopped with a good cork, when cold. If this powder be exposed to the atmosphere, the sulphuret attracts moisture from the air, and generates sufficient heat to kindle the carbonaceous matter contained in it. The following are other pyrophori:—Intimately mix together about 2 parts of sulphate of potass with 1 of lamp black; heat them to redness in a coated phial, and exclude the air carefully during cooling. Take equal parts of brown sugar and alum, and proceed as in the first receipt. Instead

of sulphate of potass in the second receipt, the sulphate of soda may be used.

PYROPHOSPHORIC ACID. When a salt of the phosphoric acid, for instance the phosphate of soda, is heated to redness, an acid arises from it, different from the phosphoric, as is shown by its forming a white precipitate with the nitrate of silver, instead of a yellow one. This acid is the pyrophosphoric. Its salts are pyrophosphates.

PYROTARTARIC ACID. An acid thus obtained:—Distil the tartaric acid. Filter the brown liquid obtained; saturate it with carbonate of potass, and evaporate to dryness. Distil this salt with sulphuric acid, diluted with its weight of water; an acid liquor passes over, succeeded by a white sublimate of pure pyrotartaric acid.

PYROTECHNY. The science which treats of the application and management of fire, particularly as applied to the art of war, and the making of ornamental fire-works, such as rockets, Bengal lights, &c.

PYROSCOPE. When one ball of the differential thermometer is smoothly covered with thick silver leaf, or inclosed in a polished sphere of silver, and the other ball is naked, it forms the pyroscope; an instrument intended by its inventor, Mr. Leslie, to measure the intensity of heat radiating from a fire into a room, or the frigorific influence from a cold body. A figure is unnecessary, as the instrument is usually made either like the differential thermometer, as represented under the word *Air*, or like *Leslie's Hygrometer*.

PYROURIC ACID. When uric acid is distilled alone it yields carbonate and hydrocyanate of ammonia, and a sublimate of pyroauric or cyanuric acid.

PYROXYLIC SPIRIT. PYROLIGNEOUS SPIRIT. BI-HYDRATE OF METHYLENE. A limpid liquid, of a peculiar odour, inflammable and volatile, hot and pungent to the taste, and not altered by exposure to the air. It is used in varnish-making, and burnt in lamps under the name of naphtha, and for other purposes, as a cheap substitute for spirits of wine. It is procured by the destructive distillation of wood, appearing along with the tar, acetic acid, and other products.

PYTHAGOREAN SYSTEM OF ASTRONOMY. The same as that of *Copernicus*, (which see,) being that adopted by all modern astronomers.

PYTHAGOREAN TABLE. The multiplication table.

PYTHAGOREAN THEOREM. A name sometimes given to the forty-seventh proposition of the first book of Euclid, which is, that the sum of the squares of the two legs of a right-angled triangle is equal to the square of the hypotenuse.



The seventeenth letter in the English alphabet, and a mute. It was unknown to the Greek and more ancient Latin authors; and when introduced was considered as representing the sound of two letters, *q* and *u*, as *qid* for quid; *qis* for quis; or otherwise, to represent the sound of *c* hard, or of *k*; as in Latin, *cuique*; or in French, *coq*, *Acqs*, &c.; in Spanish, *cuanto* for quanto. Its sound, in English, is very similar to that of *k* or *kw*. Q, as a Roman numeral, signified 500; with a dash over it 500,000. As an abbreviation, it stands for *quæstor*, *quartus*, *que*, *quod*, *quo*, *question*, &c.

QUADRA. In building, any square moulding, frame, or border, encompassing a bas-relief; also used, but erroneously, for a border of any other shape.

QUADRANGLE. In geometry, a figure of four sides; otherwise called a quadrilateral. Also a four-sided rectangular court yard or open space, inclosed by buildings.

QUADRANT. In geometry, the fourth part of a circle, made by two radii and an arc of 90° . Quadrant is also a name common to several mathematical instruments, used for measuring altitudes and angular distances, which are commonly distinguished from each other by the names of their authors, or the purposes they are intended to answer. The principle upon which the construction and use of this instrument depends may be illustrated by the annexed figure:—

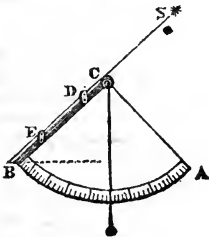

A B C is a quadrant, or quarter of a circle, of brass, wood, or other material, having the arc A B divided into degrees and minutes, from A to B. On one side B C are two fixed sights D E, and at C is fixed a plumb line. The use will be easily understood by the explanation given under *Quadrat*, which is indeed a similar instrument. The above quadrant would be extremely imperfect in practice; numberless improvements have therefore been suggested, but the quadrant of Hadley is so superior to all others that it is now universally employed in taking celestial altitudes. It is thus figured and described:—

The instrument consists of an octant, or the eighth part of a circle, A B C. An index D.

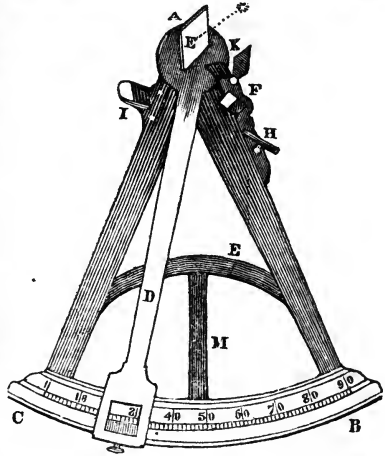

The speculum E. Two horizontal glasses F G. Two screens K, and two sight vanes H and I. The octant consists of two radii A B, A C; strengthened by the braces L M, and the arc B C, which though containing only 45° is nevertheless divided into ninety primary divisions. The index D is a flat bar, moveable about the centre of the instrument, and that part of it which slides over the scale is perforated, and contains a vernier for registering minute divisions. The rays from the object, whose altitude is required, are received on the speculum at the top E, from thence reflected on one of the sights F or I, which are two small pieces of looking glass placed on the limbs. The screens K are of colored glass, to temper the too great light of the sun or moon when their altitude is taken; a red glass being used for the sun, and a green one for the moon.

QUADRANT OF ALTITUDE. (See *Altitude*.)

QUADRANT ELECTROMETER. A most valuable instrument to ascertain the intensity of electricity, contained in any electrical apparatus, particularly a Leyden jar or battery. Its cause of action is by electrical repulsion. It consists of an upright stem of wood, the lower end of which is capped with brass, and furnished with a thick wire, that fits into one of the holes of the prime conductor of an electrical machine. The upper part of the stem is terminated by a ball, and on the side of it is a scale of degrees, numbered from the lower parts upwards. From the centre of the scale is freely suspended a thin wooden rod, at the end of which is a pith ball; this part is as light as possible. When attached to the conductor, while a Leyden jar or battery is being charged, the pith ball will rise,

and indicate by the degrees on the scale the intensity of the charge.

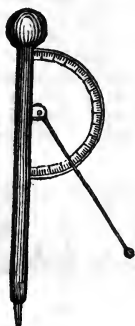

QUADRANTAL SPACE. The same as quadrant; that is, the fourth part of a circle.

QUADRANTAL TRIANGLE. A spherical triangle, having a quadrant or an arc of 90° for one of its sides.

QUADRAT. A mathematical instrument, called also a geometrical square and line of shadows. It is frequently an additional member on the face of the common quadrant. It is made of any solid matter, as brass, wood, &c., of any four plain rules, joined together at right angles; where A is the centre, from which hangs a thread, with a small weight at the end, serving as a plummet. Each of the sides B E and E D is divided into 100 equal parts, or if the sides be long enough to admit of it into 1000 equal parts. C and F are two sights, fixed to the side A D. There is, moreover, an index G H, which, when there is occasion, is joined to the centre A, in such a manner as that it can move freely round, and remain in any given situation. There are also two sights, K and I, perpendicular to the right line, going from the centre of the instrument. To measure the height of an object by this instrument, hold it in the hand, so that the eye may see the top of the object through the sights. Note the division, cut off the line E B by the plummet; this giving the angular altitude, the true altitude may be found by trigonometry.

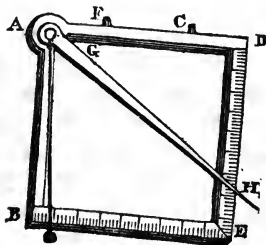

QUADRAT. In printing, a piece of metal cast like the letters, to fill up the void spaces between words, &c. There are quadrats of different sizes, called *m* quadrats, *n* quadrats, &c.

QUADRATIC, is a name given in geometry to various mechanical curves.

QUADRATIC EQUATION. In algebra, is an equation in which the highest power of the unknown quantity is of the second degree. If this power enter alone as $x^2 + 2$, it is a simple quadratic equation; if the first power is also present, it is called an affected quadratic equation, as $x^2 + x + 2$.

QUADRATURE. In geometry, is the finding a square equal in area to another figure; or in other words finding the area of plane surfaces.

QUADRATURE. In astronomy, is that aspect of the moon when she is a quadrant, or 90° from the sun, when entering the second or fourth quarter.

QUADRELS. A kind of artificial stone, perfectly square, hence their name. They are made of a chalky, or a white, pliable earth, &c., dried in the shade for at least two years. They were formerly in great request among the Italian architects.

QUADRI. In chemical compounds, signifies that the base is in the proportion of one-fourth to the combining matter; thus the quadrioxalate of potass consists of 1 part potass to 4 of oxalic acid.

QUADRILATERAL. Any figure of four sides, whether a square, a rectangle, rhombus, trapezium, or other similar figure.

QUADRILLION. The fourth power of a million; but according to the French only the square of a million, or the fourth power of 1000.

QUADRUPLÉ. Four-fold.

QUALITY. The power in any body of exciting some impression on the mind; thus, a snow-ball having the power to excite in us ideas of cold, whiteness, hardness, and roundness; this substance is said to have the corresponding qualities, or that it is cold, white, hard, and round.

QUANTITY. Any thing capable of estimation or measurement, or which being compared with another thing of the same kind, may be said to be greater or less than it, equal or unequal to it.

QUARRY. A word of very different applications. It implies, first, a place or pit, where stone, slate, chalk, &c. is dug up. Secondly, a diamond-shaped piece of glass, to be used as a window pane, such as is often seen in cathedral and cottage windows, where one point of the quarry is placed uppermost in the leaden frame. Thirdly, an arrow, with a barbed head, is called a quarry; and fourthly, the word signifies a small square tile, made for paving. It is about 6 inches square, of a red color, and impressed with

some device, which is either white, yellow, black, or blue. Examples of quarries are given under *Abaciscus*, the ancient name of this kind of material. Quarried pavements are by no means uncommon in old village churches. The following is one from a church at Oxford:—



QUARRYING SLATES AND STONES. The method of preparing them for their different uses and applications at the quarries and pits where they have been raised.

QUARRYINGS. The small pieces that are broken or chipped off from the different sorts of materials found and wrought in quarries, while preparing for different uses.

QUARTATION, is an operation by which the quantity of one thing is made equal to a fourth part of the quantity of another thing. Thus when gold, alloyed with silver, is to be parted, we are obliged to facilitate the action of the aquafortis by reducing the quantity of the former of these metals to a fourth part of the whole mass, which is done by sufficiently increasing the quantity of the silver, if it be necessary. This operation is called quartation.

QUARTER. A square panel inclosing a tre-foil or other ornament.

QUARTER. In speaking of the moon's age, is a fourth part of a lunation.

QUARTER-POINT. In navigation, is the fourth part of the measure of one of the principal points of the compass. For example, a fourth part of the distance between N. and N by E.

QUARTER-ROUND. A term that explains itself, but applied by workmen to any moulding whose contour is the arc of a circle. (See *Ovolo* and *Echinus*.)

QUARTITE ASPECT. Where two heavenly bodies are 90° distant from each other.

QUARTZ. A genus of hard, and in most cases, transparent minerals, assuming a crystalline or conchoidal structure. The former, from the shape of the crystals, is called *rhomboidal quartz*, and the latter *indivisible quartz*. Of rhomboidal quartz,

there are fourteen varieties: viz. amethyst, rock crystal, milk quartz, common quartz, prase, cat's-eye, fibrous quartz, iron flint, hornstone, flinty slate, flint, calcedony, heliotrope, and jasper. To indivisible quartz belong floatstone, quartz sinter, hyalite, opal, mellilite, obsidian, pitch stone, pearl stone, and pumice stone.

QUARTRE-FOIL. An ornament resembling a four-leaved flower; common in Gothic buildings.

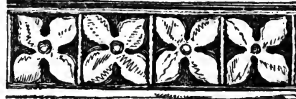

QUASSIA. A vegetable substance, discovered in quassia wood by Dr. Thompson. It is brownish yellow, somewhat transparent, and solid like an extract. It is soluble in ether, and intensely bitter.

QUEEN POST. (See *Roof*.)

QUEEN'S METAL. A white alloy, used for tea pots, spoons, &c. Its composition is 9 ozs. of tin, 1 oz. of bismuth, 1 oz. of antimony, and 1 oz. of lead.

QUEEN'S WARE. A particular kind of pottery goods.

QUEEN'S YELLOW. An old name of the turbith mineral, or yellow sub-sulphate of mercury.

QUERCITRIN. The coloring principle of quercitron bark.

QUERCITRON BARK. A most valuable drug for dyeing yellow; the bark of the *Quercus tinctoria* of North America. With the salts of iron it gives a variety of olive and drab tints, dependent upon the presence of more or less tannin, and the degree of dilution.

QUICKLIME. (See *Lime*.)

QUICKSILVER, or MERCURY. (See *Mercury*.)

QUILL. The larger feathers of the wings of birds, the barrel part of which is used chiefly for writing pens, the floats of angler's lines, and to inclose the hair in hair pencils. The feathery portion is useful to the artificial flower maker, and as the featherings to arrows.

QUINCUNX. Five-twelfths of any thing.

QUINCUNX ORDER. A peculiar arrangement of any thing in rows, so that the arti-

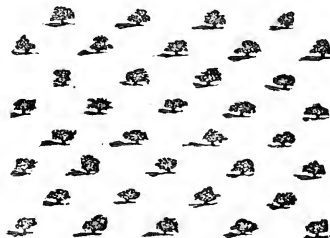

cles in one row are not opposite those of the next, but opposite to the intervals between them. This method is peculiarly applicable to planting trees and herbs, as by it a great saving of ground is obtained, and a great degree of regularity preserved. The preceding figure shows the method.

QUINDECAGON. A figure of fifteen sides.

QUINIA, or QUININE. An alkaloid, valuable in medicine, existing in the red Jesuit's bark, (*Cinchona longifolia*), in the state of kinate or quinite of lime.

QUINODIA, or QUINODINE. A substance similar to, and perhaps identical with quinine. It is extracted from the yellow bark.

QUINQUEANGULAR. Having five angles.

QUINTESSENCE. A concentrated essence, or one in which the oil preponderates over the alcohol. It is a term used chiefly in perfumery.

QUINTILE ASPECT. When two heavenly bodies are a fifth part of a circle, or 72° distant from each other.

QUINTILLION. The fifth power of a million.

QUIRK. A piece of ground taken out of any regular ground plat or floor; thus if the ground plat were square or oblong, and a piece be taken out of one corner to make a court or yard, &c., the piece is called a quirk. The irregular garden beds, cut out of grass lawns, are not usually called by any other

name than beds, although as truly quirks as any other example that can be adduced.

QUIRK MOULDING. Any moulding which is increased by an additional turn or twist, in order to give it a greater apparent projection. For example, A and B in the cut are the common ovolo and ogee mouldings. C and D are the quirked ovolo and the quirked ogee.

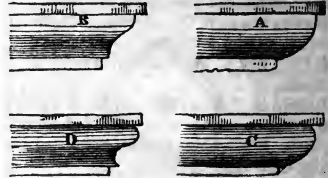

QUOINS. In printing, are the small wedges used to tighten the *furniture* around the type when it is set up. (See *Printing*.) In architecture, quoins are the stones which are placed at the angles of buildings, particularly brick buildings in order to strengthen them. When these stand out beyond the brick-work, their edges being chamfered off, they are called rustic quoins.

QUOTIENT. The quantity which arises by dividing one number by another.



The letter R is a liquid, a semi-vowel, and a lingual, the sound of it being pronounced by the action of the tongue, though this much varies in different languages, as well as in the different dialects of English. Hence independent of the varied sound which the letter properly has, others are given to it, thus, the American, the Irishman, the Yorkshireman, and the Londoner, pronounce the word "morning" very differently. The utterance of *r* is either with a trill or slight shake of the tongue, as in rhetoric, Rizzio; or when followed by *e* or *i*, pronounced rapidly—so much so, that *e* and *r* coming together, are often transposed, as children for children, perspiration for perspiration; and *i* following the *r*, is by some persons omitted altogether, as curiosity for curiosity. R, among the Latins, signified 80; among the Greeks 100; and by the Jews 200. R, on ancient coins, stands for Ravenna, Regia, Roma, Romanus, Regulus, &c; in modern times, Rex or Regina,

(King or Queen,) or for rare; RR for more rare; and RRR for unique or very rare.

RABBIT. (See *Rebate*.)

RACE, or RACE-COURSE. The cut or canal along which the water is conveyed to a water-wheel.

RACEMIC ACID. (See *Paratartaric Acid*.)

RACK AND PINION, AND RACK AND SECTOR. A rack is a straight bar of metal having cogs or teeth cut along its edge, by which it is moved up and down, in consequence of a pinion of similar sized teeth working in it; (see *Pinion*.) Sometimes the rack is moved by means of a sector, which

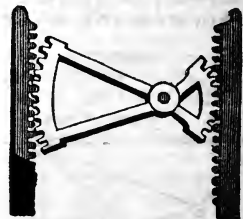

may be called the quarter of a wheel, moving the rack by an alternate motion. The preceding shows two racks moved by sectors, the velocity of each rack being in proportion to the distance from the centre of each respective sector.

RADIANT. Any thing proceeding like rays from a body; in contradiction to reflected, as radiant heat.

RADIANT POINT. Any point from which rays of light, heat, or color proceed.

RADIATION, is the shooting forth in all directions from a central point.

RADIATOR. A body from which rays emanate.

RADICAL. A term used in chemistry, as nearly synonymous with base, but more particularly applicable to the acids, as constituting their distinguishing part, by its union with oxygen or other acidifiable principle. Thus sulphur is the radical of the sulphuric and sulphurous acids.

RADICAL SIGN. In the mathematics, is the character by which the root of a quantity is expressed, and is formed thus $\sqrt{\quad}$, while the particular root is indicated by a small figure placed on the left side of it; thus $^2\sqrt{\quad}$ signifies the square root, $^3\sqrt{\quad}$ the cube root, and so on. When the radical sign stands alone, without a figure, the square root is always understood.

RADICAL VINEGAR. Strong acetic acid.

RADIUS. The semi-diameter of a globe or circle; that is, a right line drawn from the centre to the circumference.

RADIUS, is a shoot or rod, and its plural radii, or rays in English, used both literally and metaphorically. They may be the spokes of a wheel, or the beams shot by the sun.

RADIUS VECTOR, is a right line drawn from the centre of force in any curve in which a body is supposed to move by a centripetal force, to that point of the curve in which the body is supposed to be. For example:—Suppose that in the annexed cut the ellipse represents the path of a planet, and S the sun or centre of force. The lines extending from the sun to that part of the orbit in which the planet is placed will be the radius vector, and as the planet varies its distance from the sun in passing from one end of its orbit to the other, so the radius vector also varies, being at one time SA; at another SC; at others SB, SD, SE, SF, &c.

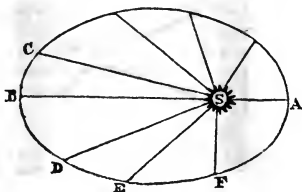

RADIX. The same as root, but used in a different sense by different authors; thus we say, the radix of a system of logarithms, a system of notation, &c., meaning the fundamental quantity on which the system is constructed, or by which all the others are compared.

RAFTERS. The sloping timbers of a roof.

RAG WHEEL AND CHAIN. A contrivance for the same purpose as the band which passes over a lathe to turn the mandril, but used where there is any very great resistance to be overcome. The rag wheel is furnished with projecting cogs or pins, at equal distances around the circumference as at A. The chain is made with links, as represented, the length of the links corresponding to the distance of the pins from each other; the chain passing round two such wheels, at some distance apart. Upon one of them being turned, the other will, by the chain catching hold of the teeth, be also put in motion.

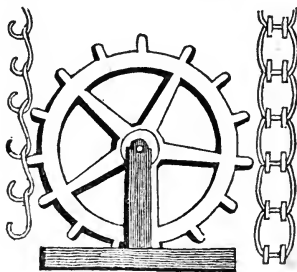

RAIL. In architecture, is particularly applied to those pieces of timber, which lie horizontally between the panels of wainscot and over and under them. In rural economy, the rails are those pieces of timber which lie horizontally from post to post in fences.

RAILWAY, OR RAILROAD. A track constructed of iron, stone, timber, or other material, for the purpose of diminishing friction, and thus serving for the easy conveyance of heavy loads, whether of carriages, of passengers, cattle, or goods.

RAILWAY SLIDE. A contrivance on a railway, for the purpose of shifting a carriage from one line of rails to another.

RAIN. A well-known phenomenon, the cause of which is explained thus:—The moisture which is always more or less present on the earth's surface, is raised into the atmosphere by evaporation. It floats there, the particles repelling each other by electrical repulsion, until some electrical change in the condition of the air takes place. When this is the case, the drops no longer repel each other, but coalesce with more or less rapidity; and being now too heavy to be buoyed up any longer, they fall either in the state of rain, hail, or snow.

RAINBOW. A circular image of the sun, variously colored. It is thus produced:—The solar rays, entering the drops of falling rain, are refracted to their farther surfaces, and thence, by one or more reflections, transmitted to the eye. At their emergence from the drop, as well as at their entrance, they suffer a refraction, by which the rays are separated into their various colors; and thus therefore are exhibited to the eye properly placed to receive them. In the following cut let E be the spectator, looking at a shower of rain, with his back to the sun. Let A be a drop of rain, and ST a ray of the sun, falling upon the upper part of it, T. Here the greater portion of the rays will suffer refraction, more or less, according to their degree of refrangibility; the violet passing to V; the red to R; and the intermediate colors between these points. Some of the rays will here be lost, but the remaining rays will be reflected to B and C, and some, as in the former instance, will pass out of the drop; but instead of being lost, as before, they will pass to the eye, situated at E, and we shall see them in the direction of the drop, or as reflected against the clouds or sky in the distance. The bow thus formed is called the *primary* bow; but there is often perceived a larger and more faintly-colored bow, exterior to the primary—this is called the *secondary* bow, and is produced by another reflection. It was seen that a ray of light falling upon the top of the drop of rain was brought to the eye after a double refraction and one reflection, but when the ray strikes the drop near the bottom, it cannot reach the eye till after two reflections and two refractions, as is seen at O. The light strikes the drop at P, it is refracted to M it passes to N. and afterwards to I. whence it would pass to the eye E; the differently colored rays separating as before, but appearing to the spectator in the reverse order. When no rain is falling between the spectator and the part of the sky at which the bow passes, a part of the bow will be wanting at that place, so that portions of rainbows are frequently seen, especially near the horizon.

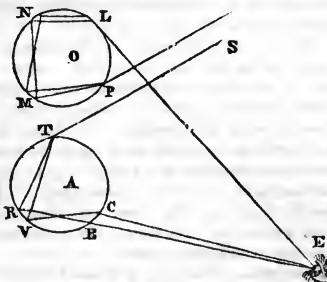

RAINBOW, Lunar. A phenomenon similar to the rainbow, but produced by the light of the moon falling upon drops of rain.

RAINBOW, Marine, or Sea-Bow. This is a phenomenon sometimes observed in a much agitated sea, when wind sweeping over the tops of the waves, carry part of them aloft, so that the rays of the sun are refracted, &c.. as in a common shower.

RAIN CLOUD. (See *Nimbus*.)

RAIN GAUGE, or PLUVIOMETER. A machine for measuring the quantity of rain that falls. There are various kinds of rain gauges. An extremely simple one may be made of a tin or copper funnel A B, the area of whose opening is exactly 10 square inches; this funnel is fixed in a bottle C, as shown in fig. 2, and the quantity of rain caught, is ascertained by multiplying the weight in ounces by 173, which gives the depth in inches and parts of an inch.

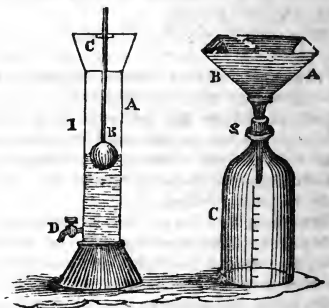

Another and superior kind of pluviometer is represented in fig. 1. It consists of a hollow cylinder A, having within it a cork ball B attached to a wooden stem, which passes through a small opening at the top, on which is placed a large funnel C. When this instrument is placed in the open air in an exposed place, the rain that falls within the circumference of the funnel will run down into a tube and cause the cork to float, and the quantity of water in the tube may be seen by the height to which the stem of the float is raised. The cock D is to empty the instrument, when necessary.

RAISER. A board set on edge under the foreside of a step, a stair, &c.

RAKING. In architecture and the arts, is a substance which is placed at any irregular angle with the surface upon which it is placed; as, for example, the erect frame at the corner of a square bay window, not being set so as to correspond with the mitre, and not agreeing with either the front or side, is said to rake.

RAM, WATER. (See *Water Ram*.)

RAMP. In hand-railing, a concavity on the upper side, formed over risers, or over a half or quarter space, by a sudden rise of the

steps above, which frequently occasions a knee above the ramp.

RAMPANT ARCH. One whose abutments spring from an inclined plane.

RAM'S HORN. A particular kind of scroll ornament, the origin of which is from the skull and horns of the ram, as seen below; though now more usually partaking of a very different and more ornamental character.



RANCIDITY. The change which oils and fats undergo by exposure to the air.

RANGE. A term applied to the edges of a number of bodies, placed on a given surface; thus, if the edges of the ribs of a groined roof were placed on a cylindrical surface they would be said to range.

RAREFACTION. In physics, is the making a body to expand or occupy more space or room, without the accession of new matter. The term is more particularly applicable to elastic fluids, which expand so as to fill the vessel in which they are contained after part is extracted. The gas becomes *rarefied* in consequence of the partial exhaustion. Liquids are expanded by means of heat, and thence become *thinner* and more *rarefied*.

RARITY. Lightness; thinness; the reverse of density.

RATCHET WHEEL. RATCHET, or RATCH. A bar or a wheel, containing angular teeth, into which a pall or detent is dropped to prevent machines from running back. As, for example, in winding up a clock or watch, the clicking noise heard is derived from the fall of the click or detent into the teeth of the ratchet wheel.

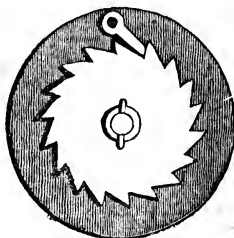

RATIO, is the relation or proportion of two or more quantities of the same kind, as to limit, quantity, or quality. (See *Proportion*; also *Arithmetical*, *Geometrical*, and *Harmonical*.)

RATIONAL FRACTIONS, is the term commonly used to express those fractions which may be decomposed into other fractions, the sum of which shall be equal to the original or given fraction.

RATIONAL HORIZON. (See *Horizon*.)

RATIONAL QUANTITIES. In algebra, are those which are expressed without any radical sign, being equivalent to integers or fractions in arithmetic, which are called rational numbers or quantities, in contra-distinction to surds.

RAY, is a single radiation from a body which sends out emissions in all directions. Rays may be convergent, divergent, or parallel, according as they are differently reflected or refracted.

RAY, Calorific. (See *Calorific*.)

RAY, Ordinary and Extraordinary. (See *Negative Axis of Double Refraction*.)

RAYS, Solar. The light which emanates from the sun, which, as already explained under *Prism*, are compound; each simple ray possessing different properties, relative to color, degree of refrangibility, illuminating and chemical power, from the rest; therefore called *prismatic rays*; *most or least refrangible rays*; *magnetising rays*; *illuminating rays*; *heating rays*, &c.

RE-AGENT. In the experiments on chemical analysis, the component parts of bodies may either be ascertained in quantity as well as quality, by the perfect operations of the laboratory; or their quality alone may be detected by the operations of certain bodies called re-agents or tests. Thus the infusion of galls is a re-agent, which detects iron by a dark purple precipitate; the prussiate of potass exhibits a blue with the same metal, &c.

REALGAR. Red orpiment, or the red sulphuret of arsenic. It is employed sometimes as a pigment, and occasionally in fireworks.

REAUMUR'S THERMOMETER, (so called from the name of the inventor,) is that in which the space between the freezing and boiling points of water is divided into 80 parts or degrees, the freezing point being marked 0, or zero, and the boiling point 80. The degrees are continued of the same size, both below and above these points, those below being reckoned negative.

REBATE, or RABBET. A channel cut in the edge of one board, that another board similarly cut may fit it; also doors fit into a rabbet cut in the door post.

RECEIVER. Generally a vessel to receive the product of any operation; for example,

the globular glass receiver attached to a retort, alembic, or matrass, shown at A. It may be either with or without a stopper. A gas receiver is of a different form, being made as shown at B. It is, when in use, placed over the hole of the pneumatic trough, and receives the gas which is made in any other apparatus. The receiver of an air pump is the large glass vessel placed over the pipe or valve, in order to be exhausted of air, being thus called from its being the recipient of those things on which experiments are made. One form of it is that of C.

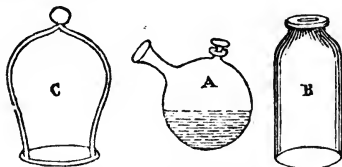

RECESSED ARCHES. One arch within another.

RECESSION. Going backwards.

RECIPROCAL. In arithmetic and algebra, is the quotient arising from dividing unity by any quantity; thus $1 \div \frac{1}{4} = 4$. Therefore 4 is the reciprocal of the fraction $\frac{1}{4}$.

RECIPROCAL EQUATIONS, are those which contain several pairs of roots, which are the reciprocals of each other; thus an equation, whose roots are $4, \frac{1}{4}; 8, \frac{1}{8}; 7, \frac{1}{7},$ &c., is called a reciprocal equation. Thus far, in fact, it differs in no respect from any other equation, in which a similar relation is known to have place between its roots; but what is most characteristic of these equations is, that they are known to be reciprocal as soon as they appear, by the order and signs of their coefficients; that is, the terms equally distant from either extreme have the same coefficient; thus $x^5 + 5x^4 + 7x^3 + 7x^2 + 5x + 1 = 0$, is a reciprocal equation.

RECIPROCAL PROPORTION, is when the reciprocal of the two last terms have the same ratio as the quantities of the first terms, or when the antecedents are compared with the reciprocals of the consequents; thus $5 : 8 :: 24 : 15$ is a reciprocal proportion, because $5 \cdot 8 :: \frac{1}{24} : \frac{1}{15}$, or $5 : \frac{1}{24} :: 8 : \frac{1}{15}$.

RECIPROCAL RATIO, is the ratio of the reciprocals of two quantities.

RECIPROCALLY. RECIPROCITY. The property of being reciprocal; thus we say that bodies of the same weight, the density is reciprocally as the magnitude—namely, the greater the magnitude the less is the density, and the less the magnitude the greater the density. So again, the space being given over which a carriage shall pass, of course, the greater the speed the less the time, that is, the velocity and time are reciprocal.

RECIPROCATING SPRING. An intermitting spring of such a nature, that instead of flowing and then ceasing to flow, alternately, it flows at one time rapidly and at another slowly; its action is of the same nature as the intermitting spring, (which see.)

RECIPROCATING STEAM ENGINE. Any steam engine which works by the propulsion, backwards and forwards, of a piston in a cylinder; the word being used in contradistinction to rotatory engine.

RECIPROCATING SYSTEM, (on a railway,) consists of a succession of stationary steam engines along the whole line, which are fixed about a mile and a half apart, having ropes from one to the other, rollers being fixed along the line to receive the same. When a train of carriages leaves a station, it is secured to the rope, and is thereby drawn along the line, in which case the rope is termed the *head rope*, and another is secured to the last waggon, which is therefore called the *tail rope*, which is thus pulled along by the train; upon returning, it becomes the head rope, and the other the tail rope, thus alternately too and fro. The rope is mostly single, being wound up at one end as it is unwound at the other.

RECKONING. In navigation, is that account whereby at any time the latitude and longitude of a ship becomes known, and hence the course she ought to steer to gain the desired port. This is sometimes made from observations, and sometimes from the log book, in which latter case it is called *dead reckoning*.

RECLINER. In dialling, is used for any dial whose plane reclines from the perpendicular, and if besides reclining it also declines from any of the cardinal points, it is called a *reclining declining dial*, and the quantity or angle at which it declines or reclines is called its *reclination* or *declination*.

RECOIL. The rebound or flying backwards of any kind of fire-arms when discharged.

RECTANGLE, OBLONG, OR LONG SQUARE. A geometrical figure whose opposite sides only are equal, and all its angles right angles, as A B C D.



RECTANGULAR. Any geometrical figure, containing one or more right angles. Solids are said to be rectangular or right, when standing perfectly erect either upon the earth or any other surface.

RECTANGULAR LEVER. A lever made in the form of two sides of a rectangle, as follows:—Its power is the same as if straight. Thus supposing the arm GB to be twice as

long as G C; a weight of one pound at P would raise up two at C. Clawed hammers used to draw nails are bent or rectangular levers.

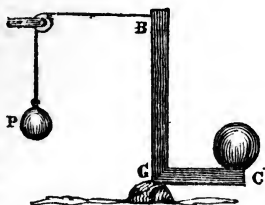

RECTIFICATION. In mathematics, is the finding of a right line equal to a proposed curve, or simply finding the length of a curved line, a problem which even in the present advanced state of analytical knowledge is often attended with considerable difficulty. In chemistry, rectification signifies the strengthening and purifying various liquids, particularly spirituous liquors, by means of re-distillation; after which process they are called *rectified spirits*.

RECTIFYING THE GLOBE, is a previous adjustment of it, to prepare it for the solution of particular problems.

RECTILINEAR. A figure or solid bounded by straight lines.

RECURRING DECIMALS. Those which are continually repeated in the same order at certain intervals, as $\frac{2}{3} = .6666$, and $\frac{3}{11} = .272727$, &c. These numbers are therefore recurring decimals.

RED. One of the primitive colors, of considerable brilliancy and liveliness. There are an infinite number of tints of red, serving to the uses of painting, as lake, carmine, vermilion, red lead, orpiment, Venetian red, red ochre, &c., which multiply their own varieties by admixture with other colors, darker or brighter.

RED CHALK. RED OCHRE. A kind of clay iron-stone.

REDDLE. Red chalk.

RED FIRE. This splendidly-colored fire, used in numerous ornamental fire-works, and in imitative conflagrations at theatres, &c., is made by mixing intimately together dry nitrate of strontian, $1\frac{1}{2}$ oz.; sulphur, 3 drachms and 6 grains; chlorate of potass, 1 drachm and 10 grains; sulphuret of antimony, 2 drachms; and charcoal, 1 scruple. The following receipt is as good and more simple:—Nitrate of strontian, 1 oz.; chlorate of potass, 3 dwts.; charcoal, 3 dwts.; and pulverized gunpowder, 3 dwts. The chlorate of potass must be powdered by itself, and mixed carefully and gently with the other ingredients afterwards, or the whole will explode.

RED LEAD. Minium, or the red oxyde of lead; used as a pigment.

RED LIQUOR. The solution of a crude acetate of alumina, employed in calico printing, and prepared from pyroligneous acid.

RED PRECIPITATE. The nitric oxyde of mercury.

RED. SAUNDERS. A dye drug; the wood of the *Pterocarpus santolina*.

RED WRITING INK. Brazil wood, boiled in water; or still better boiled in vinegar.

REDUCTION, or REVIVIFICATION. In chemistry; this word in its most extensive sense is applicable to all operations by which any substance is restored to its natural state, or which is considered as such; but custom confines it to operations by which metals are restored to their metallic state, after they have been deprived of this, either by combustion, as the metallic oxydes; or by the union of some heterogeneous matters which disguise them, as fulminating gold, luna cornea, ciunabar, and other compounds of the same kind. These reductions are also called *revivifications*.

REDUCTION. In arithmetic, is the converting or changing a quantity from one denomination or state to another, without altering its real value. Thus forty shillings are equal to two pounds—the name is changed, but the value is the same. The reduction of fractions is the bringing them into a simpler and more convenient form; thus $\frac{1}{2} \frac{4}{5}$ is equal to $\frac{2}{5}$ and $\frac{2}{5}$ of $\frac{3}{4}$ of $\frac{5}{8} = \frac{1}{4}$.

REDUCTION OF A FIGURE, DESIGN, or DRAUGHT. The making a copy of it, either larger or smaller than the original, still preserving the form and proportion. The great use of the proportional compasses is in the reduction of figures, &c., whence they are called *compasses of reduction*.

REDUCTION TO THE ECLIPTIC. In astronomy, is the difference between the argument of latitude, as N P and an arc of the ecliptic N R intercepted between the place of a planet and the node. To find this reduction or difference, there are given in the right-angled spherical triangle N P R, the angle of inclination and the argument of latitude N P, to find N R; then the difference between N P and N R is the reduction sought.

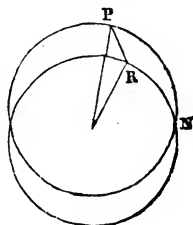

REED. That part of a loom resembling the teeth of a comb, between which the threads of the warp are separated.

REEDING. A number of beaded mouldings united together, as is often seen in chimney jambs, wooden pilasters, common picture frames, &c.



RE-ENTER. In engraving, this phrase is sometimes used to denote the passing of the graver into the incisions of a copper plate, either when worn out, or when the acid has not bitten enough, in order by deepening them to give them greater strength.

REELS. Rotatory cylinders or bobbins, on which lines, threads, &c. are wound.

REFLECTION, or REFLEXION, is a term generally used in natural philosophy, to denote the rebound of the rays of light, heat, or sound, from an opposing surface. Polished surfaces reflect the light to the eye, and are therefore more generally called reflectors or mirrors. Heat and sound are reflected without reference to the eye, and are returned from more rugged objects.

REFLECTION, Angle of. (See *Angle of Incidence and Reflection.*)

REFLECTORS. (See *Reflection.*)

REFLECTING MICROSCOPES and TELESCOPES, are those which act by reflecting the light from a specula within them to the eye; such are the Newtonian and Gregorian telescopes.

REFLECTOIRE CURVE, is a term given to the curvilinear appearance of the plane surface of a basin containing water to an eye placed perpendicularly over it. In this position, the bottom of the basin will appear to rise upwards from the centre outwards, but the curvature will be less and less, and at last the surface of the water will be an asymptote to it.

REFLEX, or REFLECT. In painting, is understood of those places in a picture which are supposed to be illuminated by a light reflected from some other body represented in the same piece.

REFRACTION. When we immerse one end of a rod in a slanting direction, in a vessel of water, the part immersed appears as if it were bent or broken at the surface of the liquid. This phenomenon is in the consequence of the rays of light, (by which the rod is rendered visible,) being bent in their course; the straight lined direction in which they originally issued, being changed by falling on another medium. Refraction is therefore used in natural philosophy as the denomination of that deviation from its course, which a body invariably experiences when passing

in an oblique direction from one fluid medium to another of a different density. The term is generally applied to the rays of light as they pass through transparent bodies.

REFRACTION, Atmospheric. As the density of the atmosphere increases from the highest limits of it, more and more, till it reaches the earth's surface, so a ray of light passing through it from the sun, &c., becomes in like manner more and more refracted, and instead of continuing in a straight line becomes bent into a curve, unless it strikes the atmosphere perpendicularly, when no refraction takes place; but becomes greater and greater in proportion as the radiant or illuminating, or, in other words, in proportion as the ray of light passes near to the horizon, thus:—

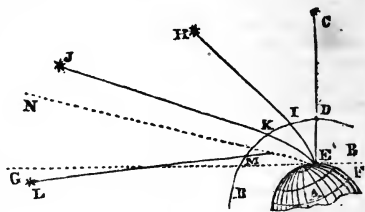

Let A represent a portion of the earth. BB the atmosphere. E the place of the spectator, and FG his horizon. The ray of light CD coming perpendicularly is not refracted, but the other rays HI, JK, and LM, are refracted, and the more so as they are nearer the horizon. Thus HI will take the course indicated by IE; JK will pass along KE; and the course of LM will be represented by ME. Now as it is a well-known fact, that objects always appear in that direction in which they last meet the eye, so in all the above cases, except the first, the ray of light or the luminous body will appear in a higher position than that it really occupies. Thus the star at L will not appear in its true place, but considerably higher up, as seen at N, and be in reality visible for some minutes after it has been below the horizon. Thus in all astronomical and nautical observations the refraction of the atmosphere must be ascertained and allowed for.

REFRACTION OF ALTITUDE, OF ASCENSION OR DESCENSION, OF LATITUDE, LONGITUDE, &c., are the alterations which take place in the apparent altitude, ascension, &c. of the heavenly body examined, which are occasioned by atmospheric refraction.

REFRACTION, Double. A peculiar kind of refraction observed in Iceland spar, and some other crystals, in looking through which an object appears double; an example of which is given under the word *Carbonate of Lime.*

REFRACTING MICROSCOPES, TELESCOPES, &c., are such as show a magnified

image of an object, by means of rays of light refracted and collected into a focus through lenses.

REFRACTIVE POWER. The various transparent media *refract* the rays of light in different degrees. Let A B, H I in the following cut be a transparent body, on which a ray C D falls or *incides* from a luminous point C, upon the plane surface A D at D. Where this ray to preserve a straight course, it would pass on to the point E; but meeting with another medium at the point D, it is reflected to F, so that the luminous point C would be seen by the eye at F, and not at E. Draw the right line C D H perpendicular to A B, through the *point of incidence* D, the angle C D G is the *angle of incidence*, and H D F is the *angle of refraction*. These angles have a fixed relation to each other, in the same transparent body, whatever the angle of incidence may be; but that proportion is different in some bodies from what it is in others, and hence those bodies are said to have a greater or less *refractive power*.

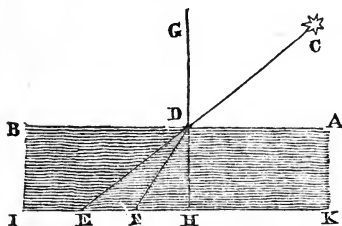

REFRANGIBILITY, is the capability of being refracted, and has been employed to designate the degree of that property which is possessed by the several divisions of a ray of light. It is owing to their various refrangibilities that the threads or rays separate from each other in passing through the prism, and thereby form the colored spectrum.

REFRIGERATOR. An apparatus designed to cool the worts of a brewhouse or any other hot liquid, which it is desirable to cool rapidly. There are numerous kinds of refrigerators in common use. That of the screw-shaped pipe, used with the still, is well known. The following is one out of the very numerous designs furnished by the inventor, Mr. Yandall, for this purpose. The principle of all is the same, namely, passing the hot liquid through or between pipes or surfaces which are immersed in cold water:— A shows a series of zigzag channels made in obliquely descending planes. B is the funnel for the hot liquor, whence it descends through the pipe D into the upper channel; passing through all the channels it is ultimately discharged through the pipe C at the

cock E. The cold water being introduced into the funnel E, and passing down the pipe I, enters and fills the spaces between the channels, and rising through the apparatus, runs off by the pipe G, and is discharged at the cock below.

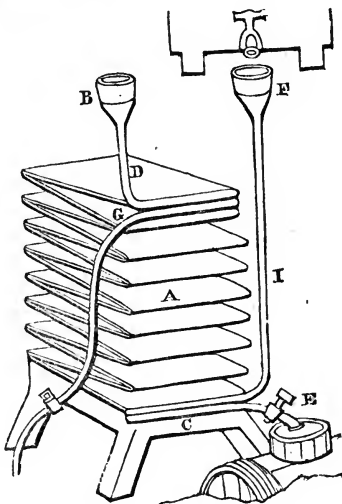

REGENERATED SEA SALT, OR THE DIGESTIVE SALT OF SILVIUS. The muriate of potass, or rather the chloride of potassium.

REGISTER. An aperture or valve placed in a chimney, stove or furnace, furnished with a turning or sliding door, for regulating the quantity of air to be admitted to the fire, or to open and shut the communication with the chimney at pleasure. A register is also any contrivance for noting down or calculating the performance of an engine, or the rapidity of a process. (See *Gas*.)

REGISTER THERMOMETERS, are those instruments which by some contrivance register the greatest or least degree of heat which has occurred since the time of the last observation. (See *Keith, Cavendish, Sir, Blackadder, Trail, &c.*)

REGLET. In architecture, a flat narrow moulding, employed to separate panels and other members, or to form knots, frets, or other ornaments, on a flat surface.

RENIER'S METALLINE THERMOMETER. This instrument consists of two plates of brass, fixed in an iron frame, in a bent position, with their concave surfaces towards each other; (see cut.) On one is a pinion of eight pallets on an axis, the end of which supports an index to mark the temperature. To the centre of the other plate is attached a toothed rack, in the position of the versed side of the curve, playing in the pallets of

the pinion. When the plates are cooled they approach each other; when heated their centres recede, and the only circumstances of consequence in the position of the bars or plates, are that they should be at some little distance from each other, and so bent that they cannot become parallel by any reduction of temperature to which they may be exposed.

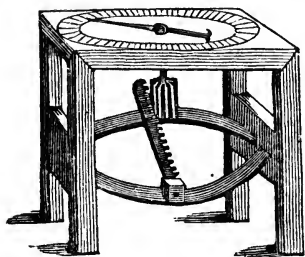

REGRATING. Among masons, &c., taking off the outer surface. &c., of an old hewn stone wall, in order to whiten and make it look fresh again.

REGULAR BODY. (See *Body*.)

REGULAR FIGURE. Any figure all of the sides and angles of which are equal.

REGULATOR. (See *Governor*.)

REGULATOR. A small lever in watch work, which by being moved increases or decreases the amount of the balance spring that is allowed to act.

REGULUS. An old name to designate a metal when in a refined metallic state, as opposed to the state of sulphuret, or other ore of the same. It is now principally applied to the regulus of antimony and arsenic.

REGULUS STELLATUS, or MARTIAL REGULUS, is an alloy formed by melting antimony and iron together.

REJOINTING. The filling up the old joints of walls with fresh mortar.

RELATION. In mathematics, is the same as ratio, although it is sometimes used in a more general sense, indicating any dependence of one number or quantity upon another.

RELIEVO. A projection of carved work. (See *alto-relievo* and *basso-relievo*.)

RELIEVO. In painting, denotes the degree of force or boldness, by which a figure seems at a due distance to stand out from the ground of the painting, as if really embossed.

REMAINDER. That which is left after taking away a number or quantity from one which is greater. It is therefore the result of subtraction.

RENDERING. A name for the first coat of plaster on walls, and to the inside of chimney flues; also called pargetting.

REPETEND. In arithmetic, denotes that part of a circulating decimal which is re-

peated, as in 1.666 the repetend is the figure 6.

REPULSION, is the name of a power or principle in the particles of natural bodies, by which under certain circumstances they refuse to meet or coalesce with each other. It is the opposite of attraction, and equally inexplicable.

REPULSION, Electrical. Two bodies electrified in the same manner repel each other, because the particles of the electric fluid are repellant one of another. Very numerous experiments exemplify this kind of repulsion; one example may suffice:—Warm a thick glass tube, then rub it with dry flannel, and lay a fleecy feather upon it; after a few moments the feather will be repelled from the electrified tube, and may by holding the tube towards it be driven about the room.

REPULSION, Magnetic. The power exerted by the similar poles of two magnets upon each other; thus two north or two south poles repel one another.

RESERVOIR. A large pond or pen of water artificially made, in order to retain and collect it for the use of canals, rivers, mills, &c.

RESIDUAL QUANTITY. In algebra, is a binomial connected by the negative sign; thus $a-b$ and $a-\sqrt{b}$ are residual quantities.

RESIDUE, or RESIDUUM. That which remains as the final result of any mechanical or chemical operation; thus coke is the residuum left in the retort after gas has been extracted from coal.

RESINS. Peculiar vegetable principles, which are known by being insoluble in water, but soluble in alcohol. They are procured in two ways, either as a spontaneous exudation from plants, or by extraction by heat or alcohol. Resins melt by the application of heat, but do not volatilise without partial decomposition. They are mostly translucent, and more or less of a brown color. A few of them are soft, but the greater number hard and brittle. They take fire by contact of an ignited body, and burn with a bright flame and much smoke; assisted by heat they combine readily with the oils, and also with alkalies, in the latter case forming soaps. The soft resins which contain a portion of essential oil, are called balsam. The hard resins are amber, anime, benzoin, colophony, (common rosin,) copal, dammara, dragon's blood, elemi, guaiacum, lac, resin of jalap, ladanum, mastic, sandarac, storax, and tacamahac.

RESIN OF COPPER. Proto-chloride of copper.

RESINOUS ELECTRICITY, or RESINOUS FLUID OF ELECTRICITY. That which is produced by the friction of resinous substances, which is contrary in its nature from that

produced by the friction of vitreous bodies. (See *Du Fay*.)

RESISTANCE, or RESISTING FORCE. Any power that acts in opposition to another, so as to destroy or diminish its effect. Of resistance there are several kinds, arising from the various natures and properties of the resisting bodies, and governed by various laws, as the resistance of solids, the resistance of fluids, the resistance of the air, &c.

RESISTANCE, *Solid of Least.* That shaped body which will be least impeded in passing through the air or water. The figure is thus:—

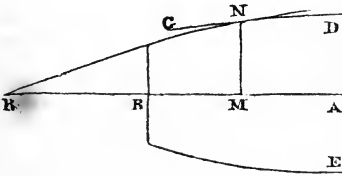

Let D N G be a curve of such a nature, that if, from the point N, the ordinate N M be drawn perpendicularly to the axis A B; and from a given point G there be drawn G B parallel to a tangent at N, and meeting the axis produced in R; then if N M be to G B as GR^3 to $4 BR \times BG^2$, a solid described by the revolution of this line about its axis A B, moving in a medium from A to B, will be the solid required.

RESOLUTION. In a general sense, is the separating of a compound body into its separate original parts.

RESOLUTION OF FORCES. (See *Parallogram of Forces*.)

REST. The continuance of a body in the same space, either relatively or absolutely. We have no example in nature of a body being absolutely at rest; thus, the earth moving, all upon it must move also; the sun himself has two motions, not merely revolving around his axis, but even in an orbit around a certain point near to his body.

REST. That part of a lathe upon which the tools are supported during the operation of turning. The ordinary rest is exhibited below, where A A represents part of the bed of the lathe. B P B is the foot of the rest. It is fastened down by means of the clamp F, which is connected with the screwed bolt and nut G. Turning this nut one way or the other, as required, loosens or fastens the rest to the bed of the lathe. C is a hollow cylindrical socket for the reception of the round shank of D. This part, which is truly the rest, and upon which the tools are held, may be loosened or held fast, and set higher or lower, as required, by means of the screw at E. The top of D is made of steel, and

quite smooth and flat. The remainder of the instrument is of iron. (See *Slide Rest*.)

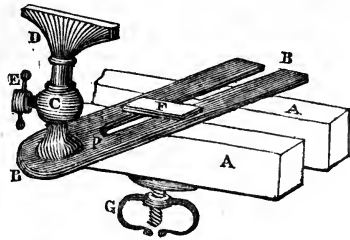

RESTITUTION, *Motion of.* A term used by some to denote the return of elastic bodies to their natural form, after compression or bending.

RESULTANT. In mechanics, is used to denote that single force or the line representing the quantity of that single force, which is equivalent to two or more forces whose quantities and directions are given.

RESULTANT FORCE. That which results or proceeds from a power exerted; the combined effect of several powers.

RETAINING WALL. A wall used for the support and maintenance of a body of earth, when circumstances render it inexpedient to slope the same gradually down.

RETICULATED WORK. A species of masonry, formed of small square stones or bricks, placed lozenge-wise.

RETINASPHALTUM. A resinous substance, which accompanies certain kinds of coal, particularly the Bovey coal of Devonshire, and some of the Staffordshire coal. It was first analyzed by Mr. Hatchett, who found it to consist of 55 parts of rosin, 41 asphaltum, and 4 earthy matter.

RETORT. A chemical instrument, for holding solids or liquids for the purpose of distillation. According to the heat that it is to be submitted to, and the nature of the substance contained, so retorts are of different forms, and made of different materials; thus for the making of various gases cast-iron retorts are commonly employed. Fluorine requires one of silver or lead. In the manufacture of the acids, earthenware retorts are mostly employed; and for ordinary purposes of distillation, and other chemical operations, glass is the material approved of;

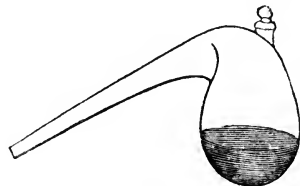

such retorts being usually made of the represented shape.

RETROGRADATION, OR RETROGRESSION. In astronomy, is an apparent motion of the planets, by which they seem to move backwards in the ecliptic, or in antecendia or contrary to the order of the signs.

RETURN. In building, denotes a side or part that falls away from the front of any straight work.

REVELS, OR REVEALS. The space between the exterior surface of a wall and the frame of a recessed window or door.

REVERBERATORY FURNACE. (See *Furnace*.)

REVERSION. An annuity which is not to commence till after a certain number of years.

REVOLUTION. In geometry, the motion of any figure quite round a fixed line, as an axis. Thus a right-angled triangle, revolving round one of its legs as an axis, generates by that revolution a cone.

REVOLUTION, *Period of.* In astronomy, is the time a planet, comet, &c., employs in passing from one point of its orbit to the same point again. This with regard to the earth determines the length of the year.

RHABARBARIN. The purgative principle of rhubarb.

RHABDOLOGY. A name given by Napier to his method of performing multiplication, division, &c., by means of small bones or rods. (See *Napier's Bones*.)

RHAPONTICIN, is a substance obtained from the *Rheum rhaponticum* in the form of yellow scales, inodorous, insipid, and insoluble in cold water; soluble in 24 parts of hot water, and in 2 of anhydrous alcohol.

RHEIN. When 1 part of powdered rhubarb is gently heated with 8 of nitric acid, sp. gr. 1.37, and the liquor evaporated to the consistence of syrup and diluted with cold water, an orange colored powder is deposited, which M. Vaudin has termed *Rhein*.

RHODIO-CHLORIDES. Compounds of rhodium and chlorine, in combination with the chlorides of potassium or sodium, thus forming double salts. They are composed of 1 atom of the perchloride of rhodium and 1 of the basic chloride.

RHODIUM. A metal discovered in 1803 by Dr. Wollaston, disseminated in an ore of platinum. It is very difficult of fusion; its specific gravity is about 11. When pure it is not soluble in any of the acids, unless previous to immersion it is alloyed to some other metal. It unites to oxygen in one proportion, forming a peroxyde; also with chlorine forming a perchloride. It forms alloys with other metals, but not with mercury. Its alloy with steel is a valuable compound.

RHOMBIC SPAR. Iceland spar, or the doubly-refractive carbonate of lime.

RHOMBOID. A geometrical figure, with the opposite sides equal, but not the adjacent sides, and the angles not right angles. The figure is shown with that of rhombus at letter A.

RHOMBUS. A geometrical figure, whose sides are all equal, and its angles not right angles, as B.

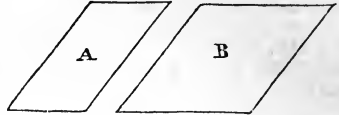

RHUMB LINE, OR LOXODROMIA. In navigation, is a line prolonged from any point in a sea chart, except in the direction of any one of the cardinal points. A ship's way is therefore not to be computed, as if her course were made in a great circle of the sphere, but as made up of the successive arcs of this line or spiral, the principles of which may be illustrated as follows:—

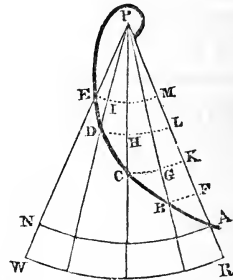

Let P be the pole. RW the equator. ABCDEF a spiral rhumb, divided into an indefinite number of equal parts at the points B C D, &c., through which are drawn the meridians PW, PR, &c., and the parallels FB, KC, D D, &c., also draw the parallel AN. Then as a ship sails along the rhumb line towards the pole, or in the direction ABCD from A to E; the distance sailed A E is made up of all the small equal parts of the rhumb AB + BC + CD + DE, and the sum of all the small differences of latitude make up the whole difference of latitude A M or EN; and the sum of all the parallels FB + GC + HD + IE is what is called the departure in plane sailing, and M E is the meridional distance, or distance between the first and last meridians, measured on the last parallel; also RW is the difference of longitude, measured on the equator; so that these last three are all different, viz. the departure, the meridional distance, and the difference of longitude.

RIBS. The mouldings upon a groined roof, distinguished by their position as groined ribs, ridge ribs, and surface ribs, horizontal, transverse, and diagonal.

RICINIC ACID. An acid obtainable from the *ricinus communis*, or castor oil.

RICOCHET FIRING. In the practical part of gunnery, is a method of firing with small charges and at small degrees of elevation, in consequence of which the ball is constantly bounding and rolling along, and thus destroying more men than a greater charge and greater elevation.

RIDGE. The upper edge of a roof.

RIDGE PIECE. The piece of timber which lies along the ridge of a roof, and to which the rafters are attached at top.

RIGGER. A cylindrical or drum-shaped pulley.

RIGGING. A general term given to all the ropes of a ship, whether to support the masts or to manage the sails.

RIGHT-ANGLE, LINE, &c. (See *Angle, Line, &c.*)

RIGIDITY. A stiffness or hardness; particularly applied to ropes and other matters which should be pliable, but which lose their pliability by want of use, wet, or some other similar cause.

RILIEVO. (See *Relievo.*)

RING. In architecture, an annulet around a column.

RING. In geometry, a surface or solid; the space between one concentric circle or oval and another cut out of it. It may be either superficial or solid.

RING OF SATURN. In astronomy, is a broad, opaque, circular body encompassing the equatorial regions of that planet at a considerable distance from him. This ring, which is very thin, (about 4500 miles,) revolves from east to west in 10 h., 29 m., 16", 8", being nearly the time of the diurnal revolution of Saturn. When examined in its most favorable situation, it is found to consist of a double ring, one within the other. The diameter of the planet is 76068 English miles; the inner diameter of the double ring is 146345 miles; the outer diameter of the outer ring 204883 miles.

RING CHUCK. A very useful chuck for many purposes, and one which is easily made. It consists of a block of hard wood, turned, and tapped with a screw at one end, to fit the screw of the mandril of a lathe. The surface is turned slightly, tapering towards the point, a hole turned some distance up

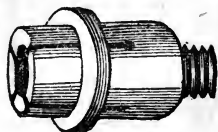

the axis, and two saw-cuts made across the axis, and continued some distance, longitudinally, up the chuck. An iron or brass ring fits tightly over the end. If the piece of wood to be turned be fitted tightly in the hole, it may be further tightened by driving the ring upwards.

RING FENCE. An estate or portion of ground is said to be inclosed by or contained in a ring fence, when a line may be carried around every part; that is to say, when a person may pass quite round it without entering another person's premises, or leaving out any of his own: or, when no part of the estate is detached from the rest by lands belonging to other proprietors.

RISING. In astronomy, the first appearance of the sun, moon, or other celestial body above the horizon.

RITCHIE'S ELECTRO-MAGNETIC ROTATORY APPARATUS. This is an extremely interesting piece of apparatus, simple in itself, and which yet shows the power of electro-magnetism, in producing rapid and powerful rotatory motion. It consists of a horse-shoe magnet A A, supported on a stand B.

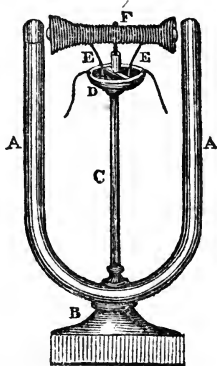

A central wire C supports a wooden cup D, which has a channel in it to hold mercury, and a bar across it to cut this channel into two cells, so that the mercury of the one does not touch the mercury of the other, and yet enough of mercury is to be put in that it may rise rather above the cross piece. F is a bar of soft iron of a length just sufficient to pass between the poles of A. It has a point proceeding from the centre, upon which it is supported upon the top of C. It is also twisted round with a coil of wire, the two ends of which dip into the mercury of the cells, but they are not so long as to be impeded by the cross bar. In the cup D are two holes, one in each cell, proceeding from the upper rim, slanting so as to touch the mercury; these holes are for the wires proceeding from an electro-magnetic battery.

z z

RITCHIE'S GALVANOMETER, is thus described and figured :—A representing the external form, and B the section of the instrument. It acts upon the principle of torsion. G is a fine thread of glass, which is suspended from the top of the frame, so that it shall be free to move the index C, which travels round a small graduated circle. The lower end of the glass filament bears two small magnets SN, placed with their poles reversed to each other. A B is a coil of fine wire, covered with silk or wax, to convey the galvanic fluid so as to influence the magnets, which magnets it may be remarked are made of common sewing needles magnetised. The glass thread is kept steady by passing through a hole made in a little arm below, and through a hole made in the centre of the upper side of the coil A B, by turning the wires somewhat aside each way. The frame is of two long strips of wood, supported on a wooden foot, and the coil and needles are inclosed in a glass box to prevent agitation from the air.

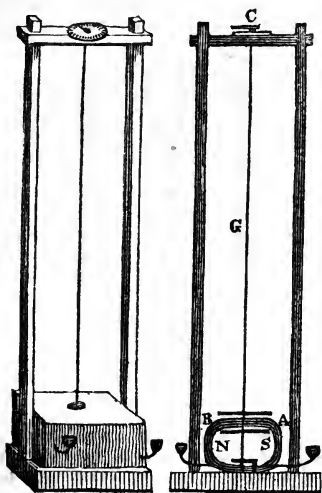

RIVER. In geography, a stream or current of fresh water flowing in a bed or channel from its source or spring into the sea.

RIVE, DE LA. (See *De la Rive*.)

ROCELLA. The name of a lichen used in dyeing.

ROCELLIC ACID. An acid extracted from the rocella weed and some other lichens. It combines with lime, forming a rocellate.

ROCHELLE SALT. Tartrate of potass and soda.

ROCK CORK. A kind of asbestos.

ROCK CRYSTAL. Quartz or silica, in a state of very considerable purity, transparent,

and crystallised in hexagonal prisms, with pyramidal terminations.

ROCK SALT. The common marine salt, or chloride of sodium, in mass, as dug up at various places, particularly near Cracow, in Poland, and at Northwich, in Cheshire.

ROCK WOOD. One of the numerous varieties of asbestos.

ROCKET. A fire-work or military projectile, which being lighted, is carried by its own conflagration to a considerable distance, and finally explodes, scattering sparks or burning materials in every direction. Rockets, as made for amusement, consist of the stick, which steadies them in their flight; the body of the rocket, which contains the composition that propels it forward; and the head of the rocket, which finally bursts and scatters stars, rains, sparks, &c. The sizes of rockets are known by the size of the cases; that case in which a leaden bullet of 2 oz. weight will just fall, is called a 2 oz. rocket, and so on for other sizes. The manufacture of rockets may be briefly stated as follows:—The case is first made, by rolling thick paper, pasted at the outer edge, round a stick of the proper size, called a *former*, until of proper thickness, which is about one-third that of the former; while still damp with the paste, tie or choke one end, leaving a hole in the middle of the choke. When the case is dry, put it in a proper sized rocket mould, and ram in, a little at a time, some of the composition. When nearly full, turn down the edges of the paper upon it, and pierce some holes through the edges when turned down—then fill up with stars, rain, or sparks, and scatter among them some loose gunpowder; close the top with a conical paper cap, and tie it on the stick, the length of which is 5 feet 1 inch for 2 oz. rockets; 5 feet 3 inch for 4 oz.; 6 feet 2 inch for 8 oz., &c., each about $\frac{2}{3}$ of an inch thick. There are several kinds of rockets. A represents a common small rocket, the head of which is supposed to be loaded with a quarter of an ounce, or more, of gunpowder. B is called a petard rocket, or one with stars, rains, &c.; the head is made of a separate

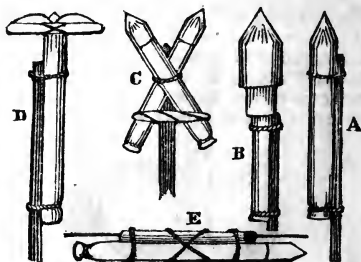

case, made larger than in the common rocket. C is called a caduceus rocket—it consists of two rockets joined together, as represented. When fired, this rocket assumes a beautifully spiral course upwards. D is an honorary rocket—it is made without a head of stars, but instead of this has a small case filled with a strong composition, which takes fire when at the highest point of the rocket's course, which, therefore, in descending, describes a beautiful scroll of fire. E is a line rocket, or one which has a second case attached to it, in which is passed a long rope; when fired, the rocket will run swiftly along the rope.

ROCKETS, Composition for. Small rockets may be filled with a composition of meal powder 1 lb. 4 oz.; saltpetre 4 oz.; and charcoal 2 oz. For large rockets, take meal powder 1 lb.; saltpetre 4 oz.; brimstone 3 oz.; charcoal 1½ oz.

ROCKET, Rains for. Golden rain:—Saw-dust 1 oz.; sulphur 2 oz.; glass-dust 3 oz.; nitre 8 oz.; and meal powder 2 oz. **Silver rain:**—Nitre ½ oz.; sulphur 2 oz.; and charcoal 4 oz. Ram it into small cases.

ROCKET, Stars for. Nitre 1 lb.; sulphur 4½ oz.; sulphuret of antimony 4 oz.; isinglass ½ oz.; camphor ½ oz.; spirits of wine ¾ oz. **White stars:**—Meal powder 3 oz.; nitre 16 oz.; sulphur 8 oz. **Blue stars:**—nitre 4 oz.; meal powder 8 oz.; sulphur 2½ oz. **Crimson stars:**—Sulphur 1 oz.; sulphuret of antimony 1 oz.; chlorate of potass 1 oz.; and nitrate of strontian 5 oz. Make into a paste with spirits of wine and isinglass, and cut up into small pieces.

ROCKET MOULD AND RAMMER. A mould in which to ram rockets, and a driver for it. The former consists of a solid wooden foot, with a projecting piece above, C, a tapering wire passing upwards, D, and a thick brass or iron cylinder A, that exactly fits on to the projection on the top of the foot-board. The hole in the cylinder exactly fits the rocket case. The rammer E is made of hard wood, with a hole drilled up it for the wire to penetrate when the rocket is rammed, the intention of the wire being to preserve a hole up the centre of the rocket, that a large quantity of the composition may be fired at once.

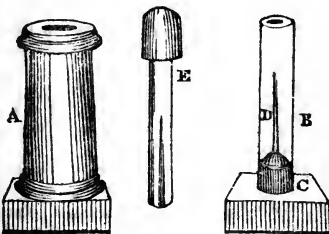

ROCK-WORK. A construction of misshapen, rough, and irregular blocks or pieces of stone, sometimes intermixed with shells, and designed to represent the unpolished and angular appearance of a surface of rock. This kind of work is principally employed to construct grottos, banks, &c.

ROESTONE, OOLITE. It is called roestone from being composed of an aggregation of very small circular grains, like those of the roe of a fish. When the grains are of a large size it is called peastone.

ROLL AND FILLET. A round moulding with a small square fillet on the face of it.

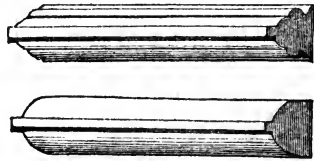

ROLL MOULDING. A moulding used in Gothic architecture, the upper half of which projects over the lower part, as if it were formed of a thick substance rolled up.

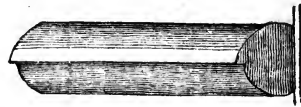

ROLLER. A cylinder of metal or wood used for various purposes. A roller placed under a heavy body will enable it to move with less friction than a wheel, that is as long as the roller's path does not deviate from the line of motion.

ROLLERS, Friction. (See *Friction*.)

ROLLING MILL. A term frequently applied to the machinery by which metals are compressed into sheets by means of rollers.

ROLLING PRESS. Under this term very numerous machines might be described, even the common mangle is a rolling press, and so may be considered the garden roller. The instrument, however, which peculiarly is called the rolling press, is that used by the copper-plate printer, and which still more frequently is called the copper-plate press. Its construction is as follows:—

AAA is a frame-work of iron or wood; at C is a large roller underneath the platform or bed of the press F. In some presses there are, instead of this, a series of small rollers under F, as in the cut; but these are not used in conjunction with the larger roller. D is a fold of flannel passed partly round the great roller; this is held up by one or two strings, with a pin to hook on to the flannel, and at the other end to pass over a pulley I, the weight K keeping the string tight. L L L are four arms, whereby the press is worked. A

properly-inked copper-plate is placed upon the table F and under the flannel, a sheet of damped paper is placed over it, and the arms being turned round, the roller D presses upon the paper and plate, and, at the same time, carries them forward to the other side; where, upon being taken up, the paper will be found impressed with the ink of the plate.

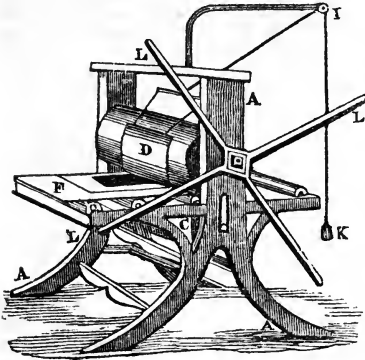

ROMAN BALANCE, or STEELYARD. (See *Steelyard*.)

ROMAN CANDLE. A particular kind of fire-work, made thus:—Take a long case, choked at one end, pour into it a thimble full of gunpowder—then a round rocket star, which has a hole pierced through it—then ram down a rocket composition to the depth of about an inch. Again pour in gunpowder, a star, and composition, as before, till the whole case is filled up. When fired, the first composition burns, throwing up sparks—then the star is ignited, and thrown upwards by the gunpowder; the same effect takes place again, and again, till the whole contents are consumed.

ROMAN CEMENT. A species of lime, which when mixed with river sand soon consolidates into an extremely hard concrete, or mortar, which is valuable in building, to imbed the brick and stone-work for foundations, as a lining for reservoirs, and particularly as a covering for buildings, defending them from the weather.

ROMAN ORDER. An order of architecture invented by the Romans from the Ionic and Corinthian orders of the Greeks, and hence it has also obtained the name of the Composite order. (See *Composite*.)

ROMAN VITRIOL. Blue vitriol, or sulphate of copper.

ROMANESQUE. A term applied to the architecture and other works of art executed during the fall of the Roman empire, including the period from the reign of Constantine to the introduction of the pointed Gothic, about the year 1100.

ROOD LOFT. The gallery over the entrance into the choir in our ancient cathedral and abbey churches, in the front of which, looking towards the west window, a large rood or crucifix was usually placed.

ROOF. A covering to a building. A roof of one row of rafters is called a *lean-to* roof; of two rows, meeting in the middle, a *span* roof; if sloped at the end a *hipped* roof; if upright at each end a *gabled* roof. Large roofs are formed upon trusses or frames of timber. The two most common trusses are the king-post truss, where a single post supports the ridge of the roof, and the queen-post truss, where two posts are placed under the purlins, as is seen in the following cuts, where the position of the principal timbers is shown:—

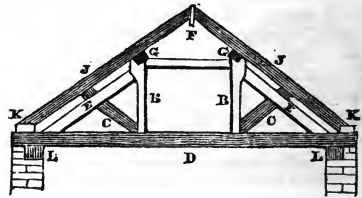
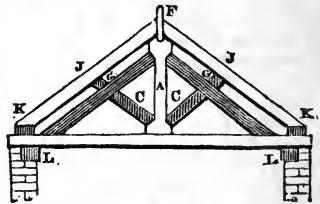

A king post. BB queen posts. CCCC braces. DD tie beams. EEEE principal rafters. FF ridge piece. GGGG purlins, which are pieces of timber running lengthwise along the roof. JJJJ common rafters. KKKK the pole plates. LLLL wall plate, on which the ends of the tie beams rest.

ROOT. In arithmetic and algebra, denotes a quantity which being multiplied a certain number of times into itself, produces another number called a power, and of which power the original quantity is called the root. If one multiplication only is necessary, it forms the second power, and the original number is called the square root. The root of a third power is the cube root; the root of a fourth power the biquadrate root, &c.

ROOTS OF AN EQUATION, are those numbers or quantities which substituted for the unknown quantity render the whole equation equal to zero.

ROPE PUMP. A machine for raising water, thus described:—A is an endless rope, that is, a rope of which the two ends are joined together; one part of it passes over the pul-

ley B at the top, the lower part passes under a similar pulley, situated at the bottom of the well, or at least under the surface of the water. C C is a frame-work to keep the rope tight, and to support the cistern at top. Over one end of the pulley B passes a rope which extends to the large wheel E. As soon as the large wheel is put in motion it turns the pulley B; this puts the rope A in motion, in consequence of which the water adheres to the rope A, and is brought upwards by the momentum it acquires. When the rope turns over at the top, the water flies off into the cistern, and flows away at D.

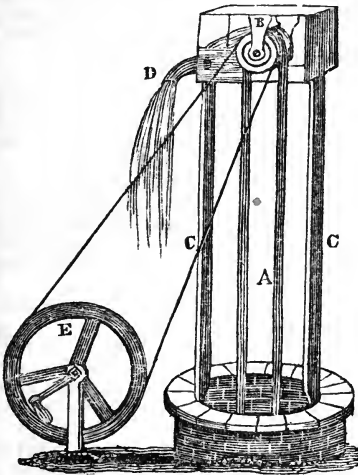

ROSACIC ACID. A peculiar acid, or as some think a modification of the uric acid, which is deposited as a sediment from the urine of persons in certain febrile disorders.

ROSE CUT. The name given to such precious stones as are cut of a smooth rounded surface, to distinguish them from such as are cut with numerous faces or facets.

ROSE ORNAMENT. A common ornament in cornices, around apertures, and in other parts of Gothic architecture, particularly that of the Tudor style. (See *Tudor Rose* and *Tudor Flower*.)



ROSE PINK. A pigment made by dyeing chalk or whiting with a decoction of Brazil wood and alum.

ROSE WINDOW. **CATHERINE WHEEL WINDOW.** **MARIGOLD WINDOW.** A circular window of the Gothic style, but not common.

The chapter house at Salisbury Cathedral has one on each side. Also a splendid window of this description is at York Minster.

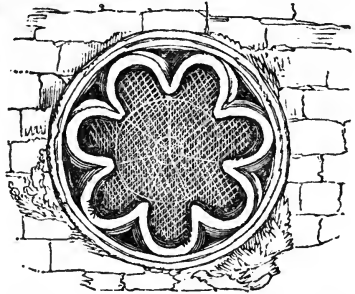

ROSEWOOD. A fine dark grained wood, which when fresh cut has a sweet rose-like scent. It is much used for cabinet work, picture frames, &c.

ROSETTE. Any ornament shaped like a rose, whether sculptured, carved, cast, made up, or painted. Thus a rosette is placed in the centre between the caulicoles or smaller tendrils of the Corinthian capital. It is also a common design for a patera, for the central ornament of a ceiling, or as one of the members of a scroll ornament. Its identical form varies with the taste of the artist.

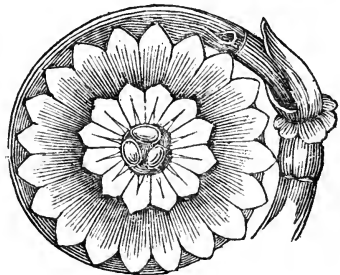

ROSIN. (See *Resin*.)

ROT, Dry. A highly destructive vegetable disease, affecting the timber in the foundations and other parts of buildings in particular soils and situations. It affects the wood in such a manner as to leave it connected by nothing but small, hard, fibrous portions, but all of which, when touched by the hand in the more advanced stage of the disease, readily moulder into a brown snuff-like dust. It is attended with a peculiar earthy smell, and has been supposed to arise from various causes. It is now clearly proved to be occasioned by the growth of a peculiar vegetable substance or mould, called *merulius lachrymans*, the spores or seeds of which are usually present in most timber, but only germinate

when under the joint influence of moisture and warmth. To preserve timber from this destructive pest, it is necessary to imbue it with some substance which acts as a poison to the dry rot. That which has been found most efficacious for this purpose is a solution of corrosive sublimate; this is called *Kyan's preservative*, and the soaking of timber in it is usually known as *Kyan's process*.

ROTA ARISTOTELICA, or **ARISTOTLE'S WHEEL**, denotes a problem in mechanics, proposed by Aristotle, concerning the motion of a coach wheel; viz., that the nave of a wheel describes by its motion, supposing it to roll along a plane, a line of the same length as the circumference, by its motion on the ground, which was long considered paradoxical; nor was it clearly understood till M. Meyran, a Frenchman, sent a satisfactory solution of it to the Academy of Sciences; the principle of which is, that every point of the circumference of the nave, as it approaches the plane, is drawn forward over a space greater than itself, whereas every point and part of the circumference passes over a space exactly equal to itself.

ROTATION. The motion of the different parts of a solid body about an axis, called the axis of rotation, being thus distinguished from the progressive motion of a body about some distant point or centre; thus the diurnal motion of the earth is one of rotation, but its annual motion one of revolution.

ROTATORY. That which rotates on a centre.

ROTATORY STEAM ENGINES. Such as act by a rotatory motion, instead of the alternate or reciprocating one of the piston and beam.

ROTTEN STONE. A soft stone, used for polishing.

ROTUNDO, or **ROTUNDA**. Any building which is circular, both within and without, whether it be a church, hall, saloon, vestibule, or any other.

ROUGE. A beautiful red coloring matter, supposed to be of an acid nature, which is extracted from the safflower, by soaking it in a solution of the carbonate of soda, and afterwards neutralising the soda by lemon juice.

ROUGH CAST. A species of plaster to cover the exterior of a building, containing lime, small shells, or pebbles, fragments of glass, &c.

RUBBER. That part of the electrical machine which rubs against the cylinder, and by the friction thus occasioned produce electrical excitation.

RUBBER, *Indian*. (See *Caoutchouc*.)

RUBBLE-WORK. A rough description of masonry, the stones being merely roughly flattened on the side which is to lay outwards, and the whole well connected by large quantities of mortar. The filling-in at the

back of arches, &c., is also called rubble-work, it not being done so carefully as the surface which is to meet the eye.

RUBY. A precious stone of a fine red color.

RUBY COPPER. Native oxide of copper.

RUDENTURE. The figure of a rope or staff, sometimes plain, sometimes carved, with which a third part of the fluting of columns is frequently filled up. It is by some called a *cabling*.

RUDERATION. An old word signifying the laying a pavement with small stones or pebbles.

RUINS. A term particularly used for magnificent buildings fallen to decay through lapse of time, and of which there only remains a confused heap of materials.

RULE, or **RULER**. A simple instrument, ordinarily of hard wood, thin, narrow, and straight, serving to direct the drawing of straight lines; sometimes marked so as to act as a measure, for feet, inches, &c.

RULE, *Parallel*. (See *Parallel*.)

RULE OF FIVE. The same as the double rule of three; so called, because it often comprises five terms, two of which, and afterwards the two others, are compared with the fifth.

RULE OF THREE. A rule in arithmetic. (See *Proportion*.)

RULE OF THREE, *Compound or Double*. A compendious method of computing questions in the rules of proportion, when there are more than three numbers to be compared together.

RULE, *Sliding*. A mathematical instrument serving to perform computations in gauging, measuring, &c., without the use of compasses, merely by the sliding of the parts of the instrument one by another, the lines and divisions of which give the answer or amount by inspection.

RUMB. (See *Rhumb*.)

RUNNER. A single moveable pulley. (See *Pulley*.)

RUPERT'S DROPS. (See *Prince Rupert*.)

RUST. The peroxyde which forms upon the surface of iron when left exposed to damp. The oxide formed by the weather from any other metal, may, with equal propriety, be considered as the rust of the metal.

RUSTIC. Any thing built in imitation of simple nature; thus we say a rustic bridge, summer-house, &c.

RUSTIC QUOINS AND MASONRY, is when the quoins, or often the whole building is so constructed, that the stones have their angles or arrises cut off at an angle of 135° with the face of the stone, so that between every two stones there is a right angular opening or joint; besides this, rustic masonry has the face of the stone chipped or marked with the chisel, sometimes round the edge of

the stones only, at others over the whole surface.

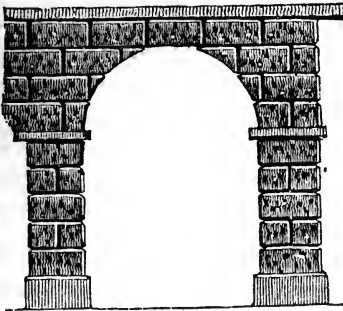

RUTHERFORD'S DAY AND NIGHT THERMOMETER, is represented in the annexed cut, where A represents a spirit, and B a mercurial thermometer, each provided with its own scale, placed horizontally on the same piece of box-wood or ivory. B contains, as an index, a bit of steel wire, which is pushed before the mercury, and is left in that situation to mark how high the temperature has been. A contains a glass index, half an inch long, with a small knob at each end; it lies in the spirit, which can freely pass beyond it, when expanded by heat; when contracted by cold, from the attraction between spirit and glass, the last film of the column of spirit is enabled to overcome the slight friction of the index on the inside of the tube, and to carry it back towards the bulb.

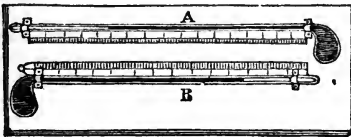

RUTHVEN PRESS. A press for the use of the letter-press printer, which is totally different from all others in the position and nature of the levers which produce the necessary pressure, as will be seen by inspection of the cut, and a comparison between it and the others previously explained under the head *Printing Press*. In the other instances, the platten is brought down so as to exert a pressure upon the form of type; but in the Ruthven press, the table and form are forced upwards against the platten, by means of forcing down the handle, which works the lever below the press. Other peculiarities will be observed; for example, the platten rolls out sideways of the press, as each printed sheet of paper is removed, while the tympan is turned up at the end. This press occupies but little space, but having the whole weight of the form to lift at each pull, much of the power is wasted. As a press, however, for working wood-cuts only, it is strongly recommended.

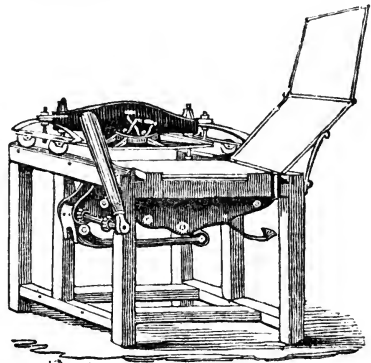

RYND. The piece of iron that goes across the hole in an upper mill-stone.

This letter abounds more in English than any other consonant—not only being used in radical words, but in numerous of their inflections, and even frequently doubled in the same syllable; hence the hissing sound so repeatedly observed in ordinary conversation. It also combines with other letters to a great extent; hence, when combined, it considerably modifies the pronunciation of them. **OF** itself, it may be considered as having two sounds; one hard, as in *this, sack,*

possess; the other soft, like *z* in *as, has, wise, &c.* S, among the Romans, signified 7; among the Greeks 200. It is the common abbreviation for *socius* and *societas*. S S signifies *sanctissime*. S, in geography, stands for *south*. In music, for *solo* or *alone*. On coins, it may imply *senatus* or *salutem*.

SABADILLINE. A peculiar crystalline substance, abstracted from the roots of the *veratrum sabadilla* and the *veratrum album*.

SACCHARINE. Any thing relating to sugar.

SACCHARINE FERMENTATION. A kind of spontaneous fermentation which takes place in various bodies, by which sugar is formed in them, at the expense of the gluten, and sometimes at the expense of an acid. Thus grain in malting from being glutinous be-

comes saccharine. Fruit also when ripening enters into the saccharine fermentation, and becomes sweet.

SACCHAROMETER. An instrument for ascertaining the strength of worts, in the preparation of malt liquors for beer, or distilling spirits. It differs in no respect whatever either in form or use from the hydrometer. (See *Hydrometer*.) It is graduated from 0 at the top to 100°. When immersed in distilled water, at the temperature of 70°, it stands at 0, but rises higher and higher in proportion to the strength, or rather the specific gravity of the liquid in which it is immersed.

SACCHOLACTIC, or SACLACTIC ACID, is procured by digesting gum arabic in concentrated nitric acid. It is also called mucic acid.

SAFETY LAMP. (See *Davy*.)

SAFETY VALVE. A valve which fits on the boiler of a steam engine, to guard against accidents by the steam obtaining too high a pressure. Its usual construction is as shown in the cut; where A indicates the boiler. B the valve, pressing air-tight into a conical hole on the top of the boiler. C is a support or fulcrum for the steelyard lever D, which is fastened to and presses down upon the valve B, with a force in accordance with the weight and distance from the fulcrum at which E is placed.

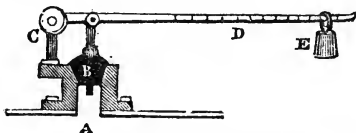

SAFFLOWER. A dyeing material for the making of rouge, and giving a pinkish bloom to lavender and other colored silks; also the material with which pink saucers are filled. It comes to this country in small compressed cakes, which are formed of the petals and stamens of the *carthamus tinctorius*.

SAFFRON. A filamentous cake, composed of the stigmata of the flowers of the *crocus sativus*. Saffron is used as a seasoning in French crockery, and to give a color to certain confectionary articles, liqueurs, and varnishes, but rarely as a pigment, though as a water color it might be used with advantage, particularly in the artificial formation of greens.

SAFFRON OF ANTIMONY. Sesquisulphuret of antimony.

SAFFRON OF MARS. *Crocus martis*, or the red peroxyde of iron.

SAG, or SAGGING. The bending of a body that would be straight while in a vertical position, but when inclined or when laid horizontally upon supporters at each end, it

becomes curved in the middle by its own gravity, when it is said to sag.

SAGO. A species of starch, extracted from the pith of the sago palm.

SAIL. A sheet of canvass, extended on a stay, yard, &c., for the purpose of receiving the pressure of the wind, and thereby communicating motion to the vessel to which it is attached.

SAIL, or WHIP. Part of a windmill. The sails of windmills are 9 yards long; the extreme ends move at a rate of about 30 miles when at their most effective speed.

SAL ALEMBROTH. A compound chloride of mercury and ammonia.

SAL AMMONIAC, Secret. Sulphate of ammonia.

SAL AMMONIAC. Chloride of ammonia.

SAL CATHARTICUS AMARUS. Sulphate of magnesia.

SAL DE DUOBUS. Sulphate of potass.

SAL DIURETICS. Acetate of potass.

SAL ENIXUM. Supersulphate of potass.

SAL GEM. Native chloride of soda, or rock salt.

SAL GLAUBERI. Sulphate of soda.

SAL JOVIS. The protomuriate of tin.

SAL MARTIS. Green sulphate of iron.

SAL MIRABILE. Sulphate of soda.

SAL PERLATUM. Phosphate of soda.

SAL POLYCHREST. Sulphate of potass.

SAL PRUNELLA. Fused nitre, cast into balls or cakes.

SAL VOLATILE. Sesquicarbonate of ammonia.

SALEP, or SALOUP, is the name of the dried tuberous roots of the orchis, imported from Persia and Asia Minor, which are the product of a great many species of the plant, but especially of the *orchis mascula*.

SALICINE. A febrifuge substance, which may be obtained in white pearly crystals from the bark of the white and other willows, and some poplars. It has a very bitter taste.

SALIFIABLE BASES, are the alkalis and those earths and metallic oxydes which have the power of neutralizing acidity, entirely or in part, and producing salts.

SALMIAC. A word sometimes used as a contraction of sal ammoniac.

SALON. A saloon, hall of audience, &c. A large apartment, usually of two stories in height, and decorated internally with architectural ornaments.

SALT, Ammoniacal, Fixed. Chloride of lime.

SALT, Arsenical Neutral, of Macquer. Super-arsenate of potass.

SALT, Common. Chloride of soda.

SALT, Digestive, of Silivius. Acetate of potass.

SALT, Epsom. Sulphate of magnesia.

SALT, Febrifuge, of Silivius. Chloride of potass.

SALT, Fusible, of Urine. Triple phosphate of soda and ammonia.

SALT, Glauber's. Sulphate of soda.

SALT, Green. In mines, the workmen give this name to the upper stratum of native salt, which is rendered impure by the admixture of clay, so when impregnated with iron it is called from its color red salt.

SALT, Marine. Chloride of soda; the same as sea salt, or our common table salt.

SALT, Argillaceous Marine. Chloride of ammonia.

SALT, Microcosmic. Triple phosphate of soda and ammonia, the same as the fusible salt of urine.

SALT, Nitrous Ammoniacal. Nitrate of ammonia.

SALT OF AMBER. Succinic acid.

SALT OF BENZOIN. Benzoic acid.

SALT OF CANAL. Sulphate of magnesia.

SALT OF CHALK. Acetate of lime.

SALT OF COLCOTHAR. Sulphate of iron.

SALT OF EGRA. Sulphate of magnesia.

SALT OF LEMONS, Essential. Super-oxalate of potass.

SALT OF RIVERIUS. Citrate of potass.

SALT OF SATURN. Acetate, or sugar of lead.

SALT OF SEIDLITZ. Sulphate of magnesia.

SALT OF SEIGNETTE. Triple tartrate of potass and soda.

SALT OF SODA. Sub-carbonate of soda; used much in the present day by the laundress, as a detergent; and to assist with tartaric acid in making an extemporaneous effervescing draught, or soda water.

SALT OF SORREL. Super oxalate of potass, the same as the essential salt of lemons. It is used to take out iron moulds and other stains from clothing or furniture.

SALT OF TARTAR. Sub-carbonate of potass.

SALT OF VITRIOL. Sulphate of zinc, otherwise called white vitriol.

SALT OF VENUS, ROMAN VITRIOL, BLUE VITRIOL. Blue stone, or sulphate of copper.

SALT OF WISDOM. The same as sal alem-broth, or a compound of the chloride of mercury and ammonia.

SALT OF WOOD SORREL. Binoxalate of potass.

SALT OF WORMWOOD. Carbonate of potass.

SALT OF PERLATE. Phosphate of soda.

SALTPETRE. Nitre, or nitrate of potass.

SALT, Rochelle. Tartrate of potass and soda.

SALT, Sedative. Boracic acid.

SALT, Spirit of. Hydrochloric acid, commonly called muriatic acid.

SALT, Sea. The common chloride of soda or table salt, procured from sea water.

SALTS, Smelling. Sesquicarbonate of ammonia.

SALT, Sulphureous, of Stahl. Sulphite of potass.

SALT, Wonderful. Sulphate of soda.

SALT, Wonderful Perlate. Phosphate of soda.

SALTS. An important class of chemical substances, composed of two or more dissimilar elements, in such combination with each other as chemically to unite, forming a substance dissimilar to either. They are divided into three orders:—First, the binary, consisting of two single members. Such are the bromides, chlorides, cyanides, fluorides, iodides, carburets, phosphorets, sulphurets, &c. Second, the bi-binary, consisting of two double members, such as those formed of an ordinary acid and alkali, as the borates, carbonates, sulphates, nitrates, &c. Third, the ternary, consisting of two single members of one genus and one of another, as the borofluorides, the sulpho-cyanides, &c. Salts also combine together in various ways for triple salts, such as the sulphate of alumina and potass, or common alum. Some chemists will only allow such compounds to be really salts which have a distinct acid principle as one of their constituents, so as to exclude the class first above mentioned. Others, considering that salts of this class contain no oxygen in their composition, have called them haloide salts, being formed of the hydracids, while all others are classed as oxy-salts, or salts of the oxy-acids.

SAND. A name given to all mineral matter that exists in minute detached grains, and more particularly denominated from some prevailing substance, as siliceous sand, iron sand, &c., or else from its derivation, as pit sand, river sand, or sea sand.

SANDAL, OR RED SAUNDERS WOOD. The produce of a tree which grows in Ceylon, and various parts of India. It is used as a dyeing material, yielding by immersion in water a deep colored red pulverulent substance, called *santaline*.

SANDARAC. A gum resin, which oozes spontaneously from the bark of the old trunks of the common juniper, and which is used in considerable quantities in the making of varnish. When pounded, it is known as *pounce*.

SANDARAC VARNISH, is made thus:—Mix, by means of the gentle heat of a slow fire, 8 oz. of gum sandarac, 2 oz. of powdered mastic, 4 oz. of clear turpentine, 4 oz. of pounded glass, and a quart of spirits of wine. The use of the pounded glass is to prevent the other ingredients from coagulating together, and thus preventing the proper action of the alcohol. Sandarac varnish is very durable.

SAND BATH. A vessel filled with sand and heated by a fire beneath, the sand being made hot, that it may convey a certain and

steady heat to any vessel immersed in it, for the purpose of drying precipitates, distilling liquids, &c.

SANDIVER, or GLASS GALL. A saline matter which rises as a scum in the pots or crucibles in which glass is made.

SANDSTONE. In mineralogy, a stone essentially composed of grains or particles of sand, either united with other mineral substances, or adhering without any visible cement. The number and variety of sandstones, and their diversity of quality, fits them for the various purposes of building stones, grindstones, filtering stones, &c.

SANTALINE. The coloring principle of sandal wood.

SAPAN WOOD. A wood brought from Japan; the produce of a species of the *casal-pina*, to which genus Brazil wood belongs. It is used in dyeing red colors—usually combined with red saunders or sandal wood.

SAP GREEN. A pigment prepared by mixing the juice of the ripe berries of the buckthorn with alum. The juice of the unripe berries has the color of saffron, and is used to color maps, &c. They are known in common under the name of French berries.

SAPONIC ACIDS, or ADIPOSE ACIDS. These substances, when solid, resemble fat, wax, or spermaceti; when liquid, they look like thin oils. They are more or less volatile; colorless when pure; lighter than water; soluble in alcohol and ether, and in the fixed and volatile oils. They are inflammable, and little affected by the air or acids at common temperatures. The greater number of these acids are not found in a separate state, but they appear to exist in oils and fats, in union with an organic base.

SAPONIFICATION. The art of converting a fatty substance into soap.

SAPPHIRE. A genus of precious stones of a blue color, and the hardest of all, except the ruby and diamond. They are found in the East Indies, in Bohemia, Alsatia, Siberia, Scotland, &c. Some are found half green and half red.

SARDONYX. A variety of cornelian, composed of layers of white and red alternately.

SASH. A checkered frame, for holding the squares of glass in a window.

SASH FRAME. The frame in which window sashes are hung,

SATELLITE. In astronomy, certain secondary planets moving round their primary planets, as the moon does round the earth. The number of satellites, at present known as belonging to our system, is eighteen; viz., the moon, the satellite of the earth; four belonging to Jupiter; seven to Saturn; and six to Uranus; but of these the moon only is visible to the naked eye. (See *Moon*.)

SATIN. A kind of silken stuff, very smooth, and shining. The woof is coarse, and hidden

underneath the warp, which is fine and prominent, and on this depends its gloss and beauty.

SATIN SPAR. Carbonate of lime, in delicate, almost compact, white fibres.

SATIN WOOD. A fine, hard, lemon-colored wood, having a fragrant odour. It grows chiefly in India, and is valued there for its medicinal virtues. Its chief use in the arts is for the finer specimens of cabinet and inlaid work, the fabrication of fans, rules, and various small articles of turnery.

SATURATION. A fluid which holds in solution as much of any substance as it can dissolve is said to be *saturated* with it; but saturation with one substance does not always deprive the fluid of its power of acting on and dissolving some other bodies, and in many cases it increases this power. A solid is also sometimes said to be saturated; thus a garment may be saturated with rain, the sand of the sea shore is saturated with water, and so on. The word saturation is also employed in another sense. The union of two principles produces a body, the properties of which differ from those of its component parts; when the principles are in such proportion that neither predominates, they are said to be saturated with each other; but if otherwise, the most predominant principle is said to be *sub-saturated*, and the other *super-saturated*.

SATURN. One of the primary planets, being the sixth, in order of distance from the sun, of the old planets, but the tenth, including the four new ones, and the outermost of all, except Uranus. This planet is, perhaps, one of the most engaging objects that astronomy presents to our view, being surrounded by a double ring and seven satellites, all visible by a moderate telescope. Saturn has also at times certain obscure belts across his disc, like those of Jupiter. His form is like that of the other planets, an oblate spheroid. His sidereal revolution is performed in 29.456 years. His distance from the sun is above 890 millions of miles. The rotation on his axis, or the length of his day, is 10 h., 16', 19", and his mean diameter 76078 miles, consequently he is nearly 1000 times as large as our earth.

SAUNDERS WOOD. (See *Sandal Wood*.)

SAUSSEUR'S CYANOMETER. (See *Cyanometer*.)

SAUSSEUR'S ELECTROMETER. This instrument is peculiarly adapted to ascertain the electrical state of the atmosphere. It consists of a glass case or bottle, with a metal bottom, four pieces of tin-foil being pasted on the sides of the glass, in connection with the bottom; withinside the glass are two very fine silver wires, swinging freely in a loop above, and ending below in two small pith balls. The upper part of the instrument

is a brass cap, terminated by a ball and a rod of three or four feet, made in joints, for the sake of greater convenience, and pointed. This instrument, when used, is to be placed in some exposed situation. When an approaching storm or other cause indicates the electric fluid in the atmosphere to be disturbed, the silver threads, by their divergence, will show the degree and character of the fluid in contact with the instrument. When it is used in rainy weather, the upper part of the glass is covered with a hood, like an umbrella, to keep the glass dry, and consequently the electrometer insulated. Such a hood is represented upon it in the figure given.



SAUSSEUR'S HYGROMETER, consists of a single human hair, suspended from a wire. The changes of moisture in the atmosphere twists or untwists the wire, when a fine index suspended at the end of it shows, by moving round a small dial plate, the degree of moisture or drought.

SAVORY'S STEAM ENGINE. This, which may truly be considered as the first that was applied to useful purposes, was called by its inventor "The Miner's Friend;" it being employed to drain mines, which it did with considerable effect. Savory constructed engines with a single, and with two steam receivers—the first appears the most simple. Its mode of action and working parts are as follows:—

A is the fire. B the boiler, the steam from which is admitted into the receiver E, through the pipe D, driving the air at first contained in it into F, and thence, by means of a valve, into the atmosphere. When E and F are full of steam, the cock M is turned, and so is the handle C, to shut off the steam, by which means water from I flows upon E, condensing the steam within it, and forming a vacuum in the vessel. In consequence of this, water rushes up from the well H, through the pipe G, at a valve at the top, until E and F are filled: then shut off the cock M, and open that at C. The steam

rushes into the receiver E, and will press upon the surface of the water, driving it up the pipe I, whence it runs away by the shoot O. The funnel and cock N are to supply the boiler with water, when required.

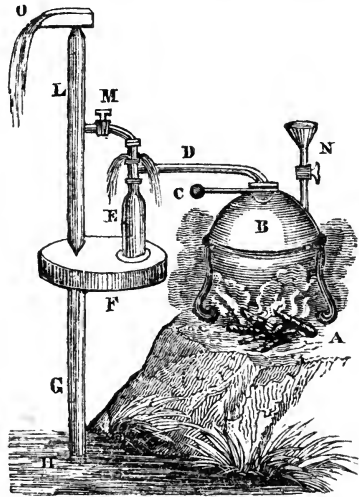

The second and more powerful engine is of a very similar nature, but has most of these parts double; thus there are two boilers and fire-places, and two receivers. Thus while the water is rising in the one receiver it is sinking in the other, so that a stream of water is projected from each alternately, and a constant supply is obtained, as well as a great economy of time and fuel.

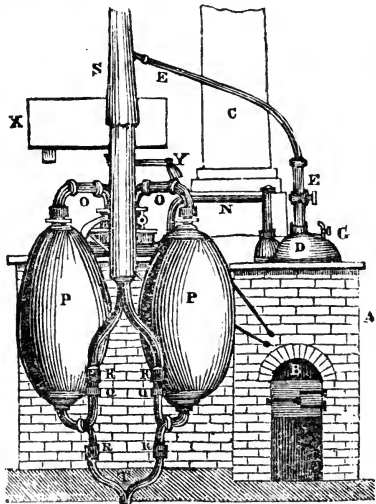

Water being admitted from D to either of the receivers marked P P, by its tube O, the air is driven out by the clack valve R. The steam is not turned off entirely at all, but turned so that it enters the other receiver P, and the cold water from Y falling upon the first P, raises the water through T, and the valve above it. Reversing the action of the steam and cold water-cocks a second time, admits the steam into the first P again, while that in the second P is condensed, the water being raised by each admission of steam. Now it is evident that the water in the boiler would, without other contrivance, be soon exhausted, but this is prevented by the double boiler, &c. Shutting the cock E, cuts off the communication between the pipe S and the small boiler D; and as D is surrounded by the fire equally with the larger boiler, and which is seen behind the receivers, the water of D becomes very soon hot, and acquires a great power of steam, greater than that of the larger boiler, whose steam is continually drawn off. When this is the case, it drives the water of D through the pipe N, (which reaches to nearly the bottom of D,) into the great boiler. The size of the small boiler D is so regulated that the water thus thrown out will sufficiently replenish the large boiler. The cock E being again turned on, water descends from S into D, ready for a future occasion. G is a gauge cock to ascertain the amount of steam or water in the boiler.

SAXON BLUE, or LIQUID BLUE, is a solution of the sulphate of indigo.

SAXTON'S MAGNETO-ELECTRICAL MACHINE. (See *Magneto*.)

SCAFFOLD. An assemblage of planks or boards, sustained by tressels or pieces of wood, fixed in the wall, upon which masons, bricklayers, &c., stand, while carrying up a wall, or for other purposes of support, at a distance above the ground.

SCAGLIOLA. An imitation of the most beautiful marbles, such as Sienna, jasper, porphyry, &c. It is hard, and when finished bears a beautiful polish.

SCALE. A line divided into a certain number of equal parts, each of which is subdivided into others, in order to express the parts of an object of a different size, either in a drawing or in a model, but in the same proportion as the original. (See *Diagonal Scale, Protractor, &c.*)

SCALENE TRIANGLE. (See *Triangle*.)

SCALLOPED MOULDING. A moulding common in Anglo-Norman edifices.



SCANTLING. The transverse dimensions of a piece of timber in width and thickness. Scantling is also the name given to all timber used for the quartering of partitions, as posts, tie beams, rafters, &c., if less than 5 inches in width and depth. Scantling in masonry is the size of the stones in length, as well as breadth and depth.

SCAPE. A name sometimes given to the shaft of a column. It is also used for the little hollow above and below which connects a shaft to its base and capital.

SCAPEMENT. (See *Escapement*.)

SCARFING. A term used to denote the junction of two pieces of timber, by being bolted or nailed transversely together, so that the two appear but as one. The joint is denominated a *scarf*, and the timbers are said to be *scarfed*.

SCENOGRAPHY. The method of representing solids in perspective. The *ichnography* is the ground plan; the elevation, a representation of the vertical places upon a vertical plane given in position, and when the whole is represented at one view, the representation is called the *scenography*.

SCHEELE'S GREEN. The arsenite of copper; a valuable pigment both for oil and water colors.

SCHEME. The representation of any thing by lines only.

SCHEME ARCH, or SKENE ARCH. A circular arch, whose dimensions are not greater than a semi-circle.

SCHMIDT'S AIR PYROMETER. (See *Air Pyrometer*.)

SCHOLIUM. A note, annotation, or remark, occasionally made on some passage, proposition, or the like. The term is much used in geometry and other parts of the mathematics; where, after demonstrating a proposition, it is frequent to point out how it might be done some other way; or to give some advice or precaution in order to prevent mistakes, or add some particular use or application thereof.

SCHOOLS OF ART. Painters understand by this term certain classes of artists, whose works are all referable to one common origin, or painted in the same style. The phrase, however, at times takes a more limited meaning, and refers to the followers of one particular meaning, as the school of Raphael, the school of Rubens, &c. In the first and most comprehensive sense, however, the schools of painting may be divided into nine; namely, the Florentine, the Roman, the Venetian, the Lombard, the Flemish, the Dutch, the German, the French, and the English. All except the three latter are now extinct.

SCHWEIGGER'S GALVANOMETER, or GALVANIC MULTIPLIER. (See *Galvanometer*.)

SCHWEINFURTH GREEN. Arsenite of copper, united with the acetate of copper, made

by adding 8 parts of arsenious acid to 9 or 10 of verdigris, previously dissolved in water.

SCIAGRAPHY, or SCIOGRAPAY. The draught of a building, &c., cut in its length and breadth to display the interior; in other words, the profile or section of it.

SCRIBING. A term applied to fitting the edge of a board to an irregular surface.

SCIENCE, denotes any doctrine deduced from facts, or self-evident principles. Thus we have natural sciences, mathematical sciences, and speculative sciences. The first depend upon our senses, the second upon our reason, and the third upon our experience. The first class opens a wide field for contemplation, comprising as it does the whole of the sciences of natural history, experimental philosophy, and astronomy. The mathematical sciences, among which are the properties of number, time, and space, absolute and relative, require the deepest exercise of the reasoning powers; and the last, or the speculative sciences, appeal to our wants, feelings, and mental capacities; such are ethics, logic, language, political economy, agriculture, &c. Notwithstanding the name given to these sciences, yet they, as well as all others, must rest upon facts only; it is to them alone to which we must look for conclusions, and upon them only can we found just or rational hypotheses.

SCIENTIFIC. Relating to or conducted by the rules of science.

SCILLITON. A white, transparent, acrid substance, extracted from squills by Vogel.

SCIOPTIC, or SCIOPTIC BALL. A sphere or globe of wood, with a circular hole or perforation, filled with a lens, and mounted in a frame, so as to turn about in any direction, being used in making experiments on light in a darkened chamber.

SCOOP WHEEL. A wheel, made like an over-shot water wheel, with buckets around the circumference. This being turned round by a steam engine or other power, scoops up the water in which the lower part of it dips, and thus raises it to a height equal to that of the diameter of the wheel; when the buckets turning over, deposit the water in a trough ready to receive it. The scoop wheel is sometimes used for irrigating lands from a neighbouring stream, or draining such as are overflowed, but seldom for any other purpose.

SCORIA. Ashes, dross, or slag, from a smelting furnace.

SCOTIA. Trochilus; synonymous with cavetto; a hollow moulding.

SCOTCHING. The operation of packing hemp before it goes to the market; also the operation of preventing a wheel, cask, roller, &c., from running down a declivity, by placing any thing under the lower side of it; or it may be scotched on both sides to keep it steady.

SCOURING. Cleansing; particularly applied to renovating articles of dress.

SCOURING BARREL. An octagonal or other shaped barrel, in which cast nails, scrap iron, &c. is cleaned from rust by friction as it revolves.

SCRAP IRON. Various pieces of old iron to be re-manufactured.

SCREEN. A light ornamental partition between one part of a church and another; or, generally, any slight division or blind.

SCREW. One of the six mechanical powers, chiefly used in pressing or squeezing things together, but sometimes also in raising weights. The screw is a spiral thread or groove cut round a cylinder, and every where making the same angle with the length of it; so that, if the surface of the cylinder with this spiral thread upon it were unfolded and stretched into a plane, the spiral thread would form a section of an inclined plane, whose length would be to its height, as the circumference of the cylinder is to the distance between two threads of the screw; as is evident from considering that in making one turn, the spiral rises along the cylinder the distance between the two threads. When the spiral thread is upon the outside of the cylinder, the screw is said to be a *male* one; but if the thread be cut along the inner surface of a hollow cylinder, or a round perforation, it is said to be *female*. This latter is sometimes called a *box* or *nut*.

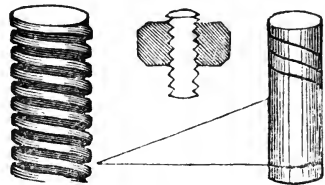

SCREW, Archimedes. (See *Archimedes*.)

SCREW, Hunter's. (See *Hunter*.)

SCREW, Micrometer. (See *Micrometer*.)

SCREW, Original. Any screw formed by a tool at once, with the intervention of dies or taps. Original screws are made in a lathe by the use of the screw tool.

SCREW, Perpetual. (See *Perpetual*.)

SCROLL. A consolidated or twisted ornament. Scroll-work adds much beauty to innumerable objects in art. The frieze of the more elaborate orders of architecture is often ornamented by a running scroll; and numerous articles of domestic ornament are thus enriched, particularly the frames of pictures and looking glasses. Good or bad taste and drawing is, perhaps, shown more in scrolls than in any other work. They should always have a regular flowing outline, in whatever style, or for whatever purpose

they may be applied. Scrolls are applicable to almost every description of running ornament. The Greek buildings were often enriched with scrolls of extreme simplicity and elegance, and of the style of which the following may convey a faint idea :—



The scroll adopted by the Romans differed but little, in character, from the last, except in being commonly more leafy, gaining in massiveness, but losing in simplicity. In Gothic architecture, scroll-work is never used, the nearest approach to it being a bunch or chaplet of intertwining leaves. The scrolls of the age of Elizabeth were massive and simple, but stiff and inelegant. Witness the following example, and also a different kind of scroll at the word *Cartouch* :—



The scroll-work of the French, particularly of the age of Louis XIV., is free, flowing, made with bold irregularity, and infinitely varied, as may be seen in the corners, crests, and other parts of looking glass frames, which will be recognised as of the following character :—



Arabesque and Moorish scroll-work combines the characters of the Greek and the French, and is, besides, intermingled with the figures of animals and grotesques.

SCRUPLE. In astronomy, the same as digit.

SCULPTURE. The art of imitating visible forms, by chiselling and working solid substances. The word properly includes images of clay, wax, wood, metal, and stone, but is generally restricted to the last material; the terms modelling, casting, and carving being applied to the others.

SCUTCHEON. ESCUTCHEON. A shield for armorial bearings; also an ornament put round a key hole, door handle, knob of a door, or other similar object.

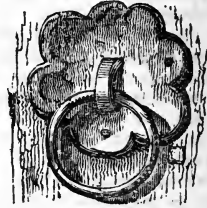

SEAL ENGRAVER'S LATHE. This very simple instrument is exhibited below. It consists of a table, upon which is fixed the mandril, or as it is here called, the mill. This is a brass upright, with a spindle through it, and a pulley upon the middle of the spindle; there being a cavity cut in the mill of sufficient size for it to fit and revolve, which it does in consequence of a string or cat-gut band which passes over the pulley, and thence to a fly wheel and foot treadle beneath the table. The tools are small pieces of steel, of various forms. A tool being inserted into a square socket at the end of the spindle of the mill or mandril, the stone to be engraved is held against the point of the tool, and at the same time a minute quantity of a thin paste, made of the oil of brick and diamond

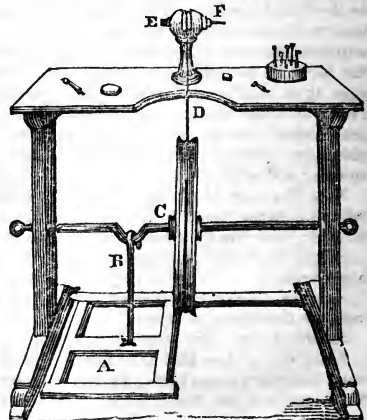

dust, or of emery powder, is placed upon the point. The stone is by these simple means gradually worn away, until it becomes a perfect scal, with initials, motto, or device, as required by the artist. In the cut, A is the treadle. B the hook, to connect it with the crank of the fly-wheel, C. D the cord. E the mill; and F the nose or spindle of it, where the tools are inserted.

SEAL, Hermetic. (See *Hermetical Sealing*.)

SEALING WAX. A composition wherewith to seal or fasten letters, and other small packets. The principal ingredient in all sealing wax is shell lac. The following receipts are recommended. *Red*:—4 ounces of shell lac, 1 oz. of Venice turpentine, and 3 drachms of vermilion. Melt the lac first, then add gradually the turpentine, and afterwards the vermilion; stir the whole well together, pour out on a marble slab, and while yet ductile roll out into sticks, by means of a smooth wooden board. *Black*:—Use ivory black, instead of vermilion. For *gold*:—Stir in gold-colored mica spangles, or bronze powder. For *purple*:—Use rose pink. For *yellow*:—Use Naples yellow, or yellow orpiment.

SEA SALT. Chloride of sodium.

SEA SALT, Regenerated. Chloride of potass.

SEASONS. Certain portions of the year regulated by the revolution of the earth in its orbit, or as it is more convenient to refer to the apparent path of the sun through the twelve signs of the zodiac, we usually say, that while the sun passes through the three first signs, or from the first point of Aries to the first point of Cancer, which corresponds with the time from the 21st of March to Midsummer, it is spring; while he passes through Cancer, Leo, and Scorpio, or from Midsummer to Michaelmas, it is summer; thence to Christmas, it is autumn; and to complete the year to March again, it is winter, or the fourth season. The reason of the seasons is the obliquity of the ecliptic; in consequence the sun shines more vertically over the northern hemisphere at one season of the year than another; therefore that portion over which he shines most direct is hotter than others which receive his rays more obliquely, making the difference between summer and winter.

SEA WAX, or MALTHA. A white, solid, tallowy-looking, fusible substance, soluble in alcohol; found on the Baikal Lake, in Siberia.

SEBACIC ACID. An acid extracted from hog's lard.

SEBATE. A salt of the sebatic acid and a base, as the sebate of lime.

SEBIC ACID. The same as sebatic acid.

SECANT. A line that cuts another or divides it into two equal parts. In trigonometry, the secant is a line drawn from the centre of

a circle to some point in the tangent, which consequently cuts the circle.

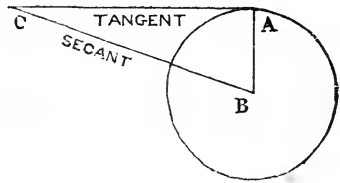

SECOND. The sixtieth part of a minute, both as it relates to the measure of angles or time.

SECONDARY CIRCLES. In astronomy, are any circles that intersect one of the great circles of the sphere at right angles. All the meridians and parallels are therefore secondary circles.

SECONDARY COIL AND CURRENT, Electro-magnetic. When the electric fluid passes along a wire, the current is called a primary current, and the wire a primary wire; if twisted around a bobbin it would be a primary coil. The influence of the electric fluid is not entirely confined to the wire which serves for its immediate conveyance, but also influences and excites a current in a second wire, which may be twisted round the bobbin which contains the first. This is called the secondary current, and this outer coil of wire the secondary coil. (See *Callan*.)

SECONDARY PLANETS. (See *Satellites*.)

SECTION. A representation of any thing supposed to be cut in two parts to show the internal structure of it. A section may be longitudinal, transverse, horizontal, or oblique.

SECTIONS, Conic. (See *Conic*.)

SECTOR. An instrument for measuring or laying off angles, and for dividing straight lines and circles into equal parts.

SECTOR OF A CIRCLE. The space comprehended between two radii of a circle and the circumference. It may be larger or less than a semi-circle.

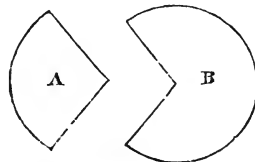

SECULAR EQUATIONS. In astronomy, are corrections required to compensate such inequalities in the motions of the heavenly bodies as are found to take place in the course of a century. Thus there are secular inequalities in the motion of the moon.

which require for their correction so many secular equations.

SEDATIVE SALT. Boracic acid.

SEEBECK'S THERMO-ELECTRIC CIRCUIT.

An instrument which shows the electric effect produced by heating dissimilar metals. It may be made of many forms. That of a parallelogram is the most usual. The two arms A and B are of one metal, for example, antimony; the other two arms C and D of a different metal, as bismuth—these are soldered at the corners. A stand supports the whole, and bears besides a small magnet, the point of suspension of which is about the centre of the parallelogram. When the heat of a flame is thrown upon either of the corners where the two metals meet, an electrical current is established, and the magnet is diverted from its polar direction, the north pole turning towards the east or west, according to the position of the two metals, that is, according to the course of the current.

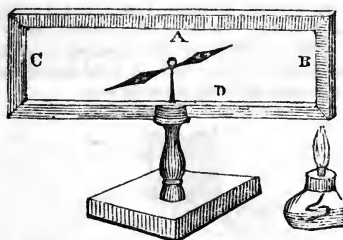

SEED LAC. (See *Lac*.)

SEGGAR, or SAGGAR, is the cylindric case of fire-clay in which fine stone-ware is inclosed while being baked in the kiln.

SEGMENT. Any part of a whole substance.

SEGMENT OF A CIRCLE. The area comprehended between an arc and a chord of a circle; that is, a portion of the surface of a circle cut off by a straight line, supposing it not to be a semi-circle.



SEGMENT OF A SPHERE, is any part of it cut off by a plane, the section of which, with the sphere, is always a circle.

SEL DE SEIGNETTE. The triple tartrate of potash and soda, or Rochelle salt.

SELENIATES. Salts compounded of the selenic acid.

SELENIC ACID. A composition of 1 part of selenium and 3 parts of oxygen.

SELENIOCYANURET. A compound of selenium and cyanogen.

SELENIOS ACID. A composition of 1 part of selenium and 2 parts of oxygen.

SELENIOS OXYDE, or OXYDE OF SELENIUM. A combination of 1 part of selenium and 1 part of oxygen.

SELENITE. In mineralogy, is the name of sparry gypsum; in chemistry, it is any salt of the selenious acid.

SELENIUM. A metalloid discovered by Berzelius in 1817. It occurs sparingly in combination with several metals, as lead, cobalt, copper, quicksilver, silver, bismuth, iron, gold, &c. It is of a bluish grey, or a reddish brown color, with a glistening metallic surface, brittle, not very hard, and with little tendency to crystallize. It softens at a temperature of 176° of Fahrenheit; is of a pasty consistence at 212° ; becomes liquid at a somewhat higher heat, forming in close vessels dark yellow vapours, which condense into black drops; but in the air the fumes have a cinnamon red color. This singular substance, apparently intermediate between the metals and sulphur, has not hitherto been applied to any use in the arts.

SELENIURET. A compound of selenium.

SELENIURETTED HYDROGEN GAS. Hydrogen contaminated with selenium.

SELF-REGISTERING THERMOMETER. (See *Six* and *Rutherford*.)

SELL. (See *Sill*.)

SEMI. In words of science, signifies a half, as semi-transparent means partly transparent.

SEMI-CIRCLE. The half of a circle contained by the diameter and the circumference.

SEMI-DIAMETER. The same as radius.

SENEGIN. A peculiar principle discovered in the senega root.

SEPIA. A pigment of a fine brown color, prepared from a black juice secreted by certain glands of the cuttle fish, which the animal ejects to darken the water when pursued. One part of it is capable of making 1000 parts of water nearly opaque. It consists of carbon in a finely-divided state, together with albumen, gelatine, and phosphate of lime.

SERALBUMEN. Albumen obtained from the serum of the blood; so called to distinguish it from ovalbumen, or that obtained from the white of eggs.

SERIES. In algebra and arithmetic, is a continued rank or progression of quantities, connected together by the signs + or -; usually proceeding according to a certain determinate law. Series receive different denominations, according to certain circumstances relative to their formation, the law which they observe, &c. A *converging* series is one in which the terms decrease, or become successive by less and less, as $1 + \frac{1}{2} + \frac{1}{4} + \frac{1}{8}$, &c. A *diverging* series is the contrary to this, or where the terms increase continually, as $1 - 2 + 4 - 8 + 16$, &c. A *neutral* series has all the terms equal, as $x + x - x + x$, &c. *Indeterminate* series is one whose terms

proceed by the powers of an indeterminate quantity, as $x + \frac{1}{2}x^2 + \frac{1}{3}x^3$, &c., and this is either ascending or descending.

SERPENTINE. A kind of marble of a fine green color, found abundantly in two or three parts of Scotland, and in the Isle of Holyhead.

SESQUI. A word signifying one and a half. It is now much used in chemistry, to designate those compound substances in which there is one proportion and a half of oxygen, chlorine, hydrogen, &c. to one of the base; thus the sesquicarbonate of ammonia contains $1\frac{1}{2}$ proportionals of carbon to each one of ammonia. The sesquioxide of lead is composed of $1\frac{1}{2}$ parts of oxygen to each one of lead.

SESQUIALTERATE RATIO, is an old mathematical term for a ratio between two numbers or lines, when the greater is equal to one and a half times the less.

SESQUIDUPLICATE RATIO, is when the greater term is twice and a half times the less.

SETTING. In astronomy, is the disappearance of any of the heavenly bodies below the horizon.

SETTOFF. (See *Offset*.)

SEWER. A subterranean channel or canal, made in cities, towns, and other places, to carry off the water and other matters.

SEXAGENARY. Something relating to the number 60.

SEXAGESIMAL. The division of a line first into 60; then each of the parts again into 60; and each of these again into 60; and so on, as long as division can be made.

SEXAGESIMALS, or SEXAGESIMAL FRACTIONS, are fractions whose denominators proceed by the powers of 60 instead of the powers of 10, as in common decimal fractions; that is, in sexagesimals, a prime or first minute is $\frac{1}{60}$; a second $\frac{1}{60} \times \frac{1}{60}$, or $\frac{1}{3600}$; but here, as in decimal fractions, the denominators being always the powers of the same number, they are not put down, their real value being indicated by the place they occupy; thus we say $26^\circ, 9', 31'', 16'''$, or 26 degrees, 9 minutes, 31 seconds, and 16 thirds. From the frequent use of these fractions in astronomy, they are often called astronomical fractions.

SEXAGON. (See *Hexagon*.)

SEXTANT. The sixth part of a circle, or an arc of 60° ; also the name of an instrument resembling a quadrant, differing from it only in its arc consisting of 60° instead of 90° .

SEXTILE ASPECT. When two heavenly bodies are at the distance from each other of 60° .

SEXTILLION. The sixth power of a million.

SEXTUPLE. Six-fold.

SHADE. SHADOW. A partial obscurity seen in such objects, or such parts of an

object as do not receive the direct rays which emanate from a luminous body. Though the above is a general definition, yet the terms shade and shadow are by no means synonymous. Shade is a general and extended mass of obscurity; but a shadow is defined, and forms a strong contrast with the illuminated portion of the object adjoining to it. Thus suppose the sun to shine through the window of a Gothic cathedral, its beams striking on the pillars, groins, pendants, &c., will occasion strong shadows behind them, while the rest of the cathedral will be in *shade* only.

SHADOWING. In drawing, the art of representing the various degrees of light and shade, by means of a dark fluid or color.

SHADOWS, the Doctrine of. In perspective, is the theory and practice of representing shadows from a given point at a finite distance, such as a candle; or as projected from the sun, where the distance, though not infinite, is for the sake of simplicity considered as such, in order that the rays may be all parallel. The following cut will show the different effect of the shadows of the same object, one of which is illuminated by the sun, the other by a candle:—

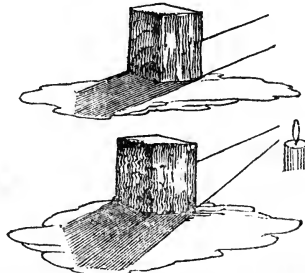

SHAFT. In mill-work, is a large axle, in contra-distinction to a spindle or small axle; thus we say the shaft of a fly-wheel, the spindle of a piston. Shafts are said to be *lying* when in a horizontal position, and *vertical* when they are upright.

SHAFT. In engineering, is a vertical sinking or well, excavated and dry, for the purpose of working or ventilating mines, also tunnels, and for ascertaining the nature of the ground before commencing any engineering operations. The principal shaft of a mine is usually called the engine shaft.

SHAFT. That part of a column between the base and the capital.

SHAFT OF A CHIMNEY. That part of it above the roof.

SHAGREEN. A peculiar substance somewhat similar to parchment; used occasionally to cover spectacle and other small cases. It is prepared from the skins of horses, camels, &c.

SHAKE, or SHAKEN. Terms used of timber that is rent by drying too suddenly, in which the fissure occasioned by too great a heat is called a *shake*.

SHAKY TIMBER. That which is full of shakes or cracks.

SHAMMEY, or rather CHAMOIS. A very pliable kind of leather, originally prepared from the chamois goat; now manufactured from the skins of sheep or lambs, and known by the name of wash-leather.

SHANKS, or LEGS. The spaces between the glyphs of a Doric frieze.

SHAPE. In all the arts, form, external appearance. The word shapely is used when speaking of any object, the proportions of which are elegant and harmonious.

SHEAR STEEL. So called, because fitted for making clothiers' shears, scythes, &c.; is prepared by laying several bars of common steel together, and heating them in a furnace until they acquire the welding temperature. The bars are then beaten together with forge hammers, after which they are drawn anew into bars for sale.

SHEAVE. A single pulley, used either as an alterative of motion, as in a block or crane, or to prevent the friction of a rope running along it; such are placed on those railroads which are worked by stationary engines, or on the reciprocating principle, to sustain the weight of the rope which draws the carriages, and prevent its friction on the ground, or its deviation from the centre of the road.

SHELF. Among miners, the strata which they find lying in a very even manner.

SHELL-LAC. (See *Lac*.)

SHIDES. The same as shingles, (which see.)

SHIELD. Synonymous with scutcheon, but more applied to a surface representing the ancient defensive armour which goes by that name.

SHIFT. The name employed in reference to the gangs of men employed in excavating and other works; for instance, when two different sets of men are employed alternately, they are described as working *double shifts*. The word double here appears superfluous, shift of itself implying a change; thus shifting the wheels of a carriage, is the changing them for each other, or a man may shift a tool from one hand to the other, or a board or bar end for end.

SHILLIBEEB'S GALVANIC BATTERY AND POLE DIRECTOR. The instruments are thus described and figured by the inventor:—The apparatus consists of a well-made copper trough, about 3 inches deep and $2\frac{1}{4}$ wide, divided into compartments, according to the number of zinc plates employed; (see cut, which represents a section of the trough that receives the plates.) These plates are sol-

dered firmly to a copper bar, and by the aid of a screw are fastened to a piece of hard wood, answering for a cover to the trough. In a groove cut out of the cover, on each side the screw, is fitted a copper slide, and these slides are joined by an elbow to a piece of ivory forming a handle, which passing immediately above the screw, each wing of the slide may be brought readily into contact with the copper or zinc. The use of this movement or pole director I will endeavour to make apparent. In the figure, let A represent a section of the wood cover, with a groove for the slide to stand in. B the screw, in connection with the zinc. C C the opposite side of the copper trough. D E the two wings of the slide. Now let the wing D D be in contact with C, and E with B; it is evident that the stream of electricity is going out from the wire in connection with the wing D, and is returning by the wire appended to E into the zinc plates, by way of B. Shift the slide so that E be in connection with C, and D with B; the stream will be reversed, making its exit by E, and returning by D through B. The zinc plates should be covered tightly with a membrane, so as to prevent any deposition of copper upon them; a solution of the sulphate of copper being that with which the copper cells are filled, while salt and water fills the membrane.

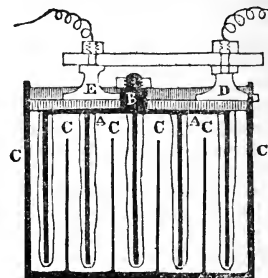

SHINGLES. Pieces of wood, cut about 12 inches long and 4 wide, one edge of them being thin, the other thick; used instead of tiles for flooring. The external covering of spires is often of this description. The boards before cut into lengths are called weather boards.

SHOAD. A term given by miners to stones containing ore, mixed with rubbish, in a loose soil, and sometimes near the surface. When deep, the miners consider it as indicating that some vein is at no great distance.

SHOAR. A prop or support, placed obliquely against any thing to hold it up, so that it may not fall forwards, while it may be undermined, or its proper perpendicular supports taken away, loosened, or repaired.

SHOCK, ELECTRIC. The rapid passage of a current of the electric fluid through any thing, particularly through any part of the animal body; when it occasions a sudden convulsion of the muscles, similar to that caused by a blow. The shock passing from a common electrical battery is sudden, instantaneous in its passage, and momentary only in duration; that from the galvanic and magnetic battery is more continuous.

SHOE. The part at the bottom of a water trunk or leaden pipe, for turning the course of the water.

SHOOTING STARS. (See *Aeroliths*.)

SHRINE. A small chest or coffer, for containing the ashes of saints or other holy relics.

SHUTTLE. The instrument employed in weaving to hold the bobbin of silk, cotton, &c., with which the cross threads are made. The weaver throwing the shuttle backwards and forwards through the alternately-raised long threads, the silk, cotton, &c., unwinds, and leaves a cross thread behind it in its course.

SHWAWPAN. (See *Swanpan*.)

SIDE. In geometry, is used for any line which forms one of the boundaries of a right-lined figure, as the side of a triangle, square, &c.

SIDE CUTTING. A term applied to earth cut away on the side of a canal or rail-road, for the purpose of obtaining material for an embankment, when there is not sufficient excavation upon the line to form it.

SIDE FORMING. A road-way formed by paving down part of a hill or other steep, so as to form a road upon the side of it or near the bottom; in the latter case by means of the earth thrown down.

SIDELING GROUND. Such as is inclined or sloping.

SIDERIAL. Any thing relating to the stars. (See *Day and Year*.)

SIDERUM. Bergman's name for phosphuret of iron.

SIDING, PASSING PLACE, OR TURN OUT, (on railways.) A short line of additional trackway laid by the side of railway, and connected therewith at each extremity by suitable curves; the rails being constructed and disposed in such a manner, that the carriages can either proceed along the main line or turn into the siding, as may be desired. To accomplish which, the portion of rails forming the junction of the siding with the main line is made moveable to suit either trackway, and is termed a *switch*. The occurrence of sidings is most frequent in the vicinity of depôts and stations.

SIEVE. An instrument for separating the smaller particles of substances from the grosser.

SIGNS. In algebra and arithmetic are

symbols employed to indicate certain operations, as addition, subtraction, &c.

SIGNS OF THE ZODIAC. (See *Zodiac*.)

SILEX. (See *Silica*.)

SILICA. The earth which constitutes nearly the whole of rock crystal, flint, and other stones of the quartz family. It was formerly considered as a pure earth, but it is now considered by chemists as of an acid tendency, and called silicic acid. Pulverized and assisted by heat it dissolves readily in the alkalies potass, and soda, forming what is called soluble glass, and is then soluble in water, making the *liquor of flint*. Silica, when pure, is a white powder, rough to the touch, gritty between the teeth, insoluble in water and acids, except in the fluoric acid.

SILICATES. Compounds of silicic acid, and the bases alumina, lime, magnesia, &c. They constitute the greater number by far of the hard minerals which encrust the terrestrial globe.

SILICEOUS. Containing flint or silica.

SILICIC ACID. (See *Silica*.)

SILICON, called also **SILICIUM,** the base of silica. It may be obtained by burning potassium in silicated fluoric gas. The product of the combustion is a brown cinder, which, on being thrown into water, disengages hydrogen with violence, and lets fall a dark, liver-colored powder, upon which water exercises no action. This matter is silicon mixed with a salt of difficult solution composed of fluorine, potassium and sodium. The salt may, however, be removed by a great deal of washing.

SILK. A glossy fibrous substance, the produce of different species of the silk-worm, and woven in numberless fabrics, and textile articles.

SILL, CILL. The horizontal part below a window or door, whether of wood or stone.

SILOUETTE. The profile of a person's face, not painted according to natural colors, nor yet in outline, but the exact side face, painted so as to present an even black surface.

SILOUETTE, OR PROFILE INSTRUMENT. A contrivance for taking the exact outline of an object, particularly the outline of a person's side face, the surface within which outline is mostly filled up with a black color, forming a silhouette. The instrument is as follows:—

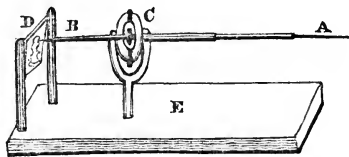

AB is a slender rod, 6 or 8 feet long, which is suspended by gimbals at C, so that

Patented by Schmalder

it has freedom of motion in every direction, the end B moving contrarywise to A. D is a small frame, hanging on two uprights, or in any other convenient mode, so that it bears very slightly upon the point B, where there is a pencil placed. E is the foot-board of the whole. Now it is evident that as A is moved, so will B move also, and trace at the same time its course upon a piece of paper, if that piece of paper be suspended on D. We have then only to pass the end A over the face of an object or person, and a counterpart will be traced on D, the size of which will be in proportion to the originals, as A C is to C B.

SILT. The alluvial soil washed down, and deposited upon the bottoms and sides of rivers, by the action of the tides; the term is also indicative of any soft light description of soil.

SILURUS ELECTRICUS. A fish of the ray kind, which gives shocks similar to those of the *gymnotus electricus* or electrical eel.

SILVAN. A name given by Werner to tellurium.

SILVATES. Compounds of the silvic acid.

SILVER. A well-known metal of a whiter color and brighter lustre than any other; it melts at a bright red heat. It is exceedingly malleable and ductile, affording leaves not more than the ten thousandth of an inch thick, and wire much finer than a human hair. Pure atmospheric air scarcely alters it, but such as is contaminated with smoke or sulphureous vapors soon covers it with a brown sulphuret. It is distinguished from gold and platinum by its readily dissolving in nitric acid; and from other metals by its salts (except its chloride), forming white curdy precipitates, with a minute quantity of sea salt, or any other soluble chloride. Silver unites with oxygen in two proportions forming oxydes; also with sulphur, chlorine, phosphorous, &c., and forms valuable alloys with the other metals.

SILVER, German. An alloy much used for domestic articles, such as forks, spoons, &c. Its composition is 8 parts of copper, 2 of nickel, and $3\frac{1}{2}$ of zinc. A better kind is made by adding 1 part more of nickel.

SILVERING. The art of covering any thing with silver, or sometimes covering it with what resembles silver in appearance, though not really such. Silvering such articles as picture frames is performed by painting over the material with an adhesive varnish, and then laying on silver leaf. Copper may be silvered over by rubbing it with the following powder:—2 drachms each of tartar and common salt, and $\frac{1}{2}$ a drachm of alum, are mixed with 15 or 20 grains of silver, precipitated from nitric acid by copper. The surface of the copper becomes white when rubbed with

this powder, which may afterwards be polished with leather.

SILVERING OF CLOCK DIALS, SCALES OF BAROMETERS, &c., is performed by rubbing upon them a mixture of muriate of silver, sea salt, and tartar, and afterwards carefully washing off the saline matter with water.

SILVERING OF PINS, is effected by boiling them with tin filings and tartar.

SILVERING GLASS GLOBES, &c., is done with an amalgam, consisting of 1 part by weight of lead, $\frac{1}{2}$ a part of lead, the same of pure tin, and 2 parts mercury. The solid metals are first fused together, and when nearly congealed the mercury is added. A very gentle heat is sufficient to fuse this amalgam. In this state it is poured into a clean glass globe, intended to be silvered, by means of a paper funnel, which reaches to the bottom. At a certain temperature it will stick to the glass, which by a proper motion may thus be silvered completely, and the superfluous amalgam poured out.

SILVERING OF LOOKING GLASSES, is done by laying out a sheet of tin foil, and spreading over it some mercury with a hare's foot; these metals will unite, and the sheet of glass being carefully slipped over it, so as to exclude air bubbles, and pressed with a heavy weight, it will unite with the metal, and become what is commonly called silvered.

SILVIC ACID, is an acid produced from common rosin. It is of no useful application in the arts.

SIMA, or SIMA RECTA. (See *Ogee*.)

SIMILAR BODIES. In physics, are such as have the same component parts.

SIMILAR CURVES, are such, that any right-lined figure being inscribed within the one, a similar rectilinear figure may be inscribed within the other.

SIMILAR ELLIPSES. Parabolas and hyperbolas are such as have their axes and parameters proportional.

SIMILAR FIGURES. Those of which the several angles are respectively equal, with the sides about the equal angles proportional. The following are therefore similar though not equal:—



SIMILAR SECTORS AND SEGMENTS, are those contained under equal arcs.

SIMILAR SOLIDS, are those which are contained under the same number of similar faces alike placed; or such as have their solid angles equal each to each, and all such

bodies are to each other as the cubes of their like sides.

SIMILITUDE. The relation of things that are similar to each other.

SIMILOR. A gold-colored variety of brass.

SIMPLE. That which is mixed or compounded of other quantities or things.

SIMPLE EQUATION. In algebra, is that in which only the simple power of the unknown quantity enters, as $7ax = b$; or $3x + ax = b$.

SIMPLE GALVANIC CIRCLE. (See *Circle*.)

SIMPLE QUANTITY, is that which consists of but one term as $4ab$; a^2 ; $20b^2$, &c.

SIMPLE, or SINGLE MICROSCOPE. (See *Microscope*.)

SINE, COSINE, AND VERSED SINE OF AN ARC. In trigonometry, the sine of an arc is a right line drawn from either extremity of an arc, perpendicular to the radius, joining the other extremity, and the centre of the circle; or it is half the chord of the double arc. Thus the line DE, in the following figure, is the sine of the arc BD, because it is drawn from the extremity D of the arc BD, perpendicular to the radius CB. Hence also DE is the sine of the arc AD. Hence every angle and its supplement, or what it wants of 180° , have the same sine common to both. The *cosine* is the complement of the sign, or what it wants of 90° , the word *co* being merely a contraction of the word complement. Thus DH, or its equal CE, is the cosine of the arc BD, as is also of the arc AD; only in the latter case it is accounted negative. The *versed sine* is that part of the diameter intercepted between the sine and the extremity of the arc. Thus EB is the versed sine of the arc DB and AE, the versed sine of the arc AD; also GH is the versed sine of the arc DG, or the co-versed sine of the arc BD.

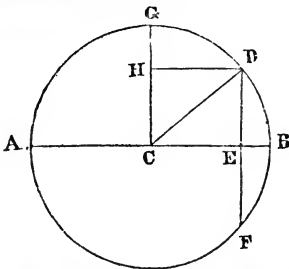

SINES, Arithmetic of, is a term frequently employed to denote that branch of science which exhibits the relation of the sines, cosines, tangents, &c., of arcs.

SINES, Law of the. When refraction takes place in any media, the ratio between the *sines* of the angles of incidence and of refraction is constant, and is termed the index

of refraction. Thus in water, if the sine of the angle of refraction be taken as unity, that of incidence will be $1\frac{1}{3}$; and therefore, the index of refraction in water is marked as 1.336. This is called the law of the sines.

SINGER'S ELECTRICAL COLUMN. (See *De Luc's Dry Pile*.) which is the same instrument, Singer having only arranged it in a neater and more convenient form.

SINGER'S ELECTROMETER. An improvement upon Bennett's gold-leaf electrometer, inasmuch as it has a double insulation, and therefore retains its electricity for a longer period. The instrument is represented annexed. The outer case is of glass, with a wooden foot and brass top, through the centre of which top passes a glass pipe of about half an inch internal diameter. A small brass table rests upon this, and a wire proceeds from the brass table downward through the glass pipe, and terminates in two slips of gold-leaf, the wire not being allowed to touch the glass tube, in consequence of silk being twisted around it in two places. A body slightly electrified held towards the upper table so influences the instrument that the gold leaves diverge.



SINGLE FLOOR AND SINGLE FRAME. A floor with only one tier of joists.

SINGLE HUNG. An expression applied to window sashes, when only one of them is moveable in the same vertical plane.

SINICAL QUADRANT, is a quadrant made of wood or metal, with lines drawn from each side, intersecting each other, with an index divided by sines, also with 90° on the limb, and sights at the edge. This quadrant was formerly used for taking the altitude of the sun, but it is grown into disuse since the great improvement in the construction of other instruments for the same purpose.

SIPHON, or SYPHON. A bent tube used in drawing off wine, liquors, and other fluids; the principle of which may be illustrated as follows:—If one end of the siphon or bent tube MNO be put into a vessel of water, and the other end without be lower than the surface of the water, then, if the air be drawn out, the water will ascend in the leg MN in consequence of the pressure of the atmosphere on the external surface of the liquid, from which it will descend to O by its own gravity, and be there discharged, and will continue to flow until the water is below the M end of the siphon, or until it gets even with the mouth O, whichever may first happen. The atmosphere presses equally upon both ends of the siphon, when the latter is full of water;

but the water flows out of, that is, falls from the longer tube, because the perpendicular height of the water is greater in that than in the shorter tube, consequently they do not balance each other, but the heaviest falls; and as the water continually flows upwards to supply the deficiency, or fill the vacuum thus occasioned, the flow is constant. For practical purposes, the siphon is usually made with a cock to shut off the stream, when required, and a mouth pipe to draw away the air, and give it the first impulse, as is represented in A.

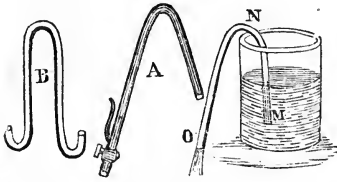

SIPHON, Wirtemberg, is a peculiar form given to this instrument, to obviate the difficulty there is in withdrawing the air from a large tube. It is as shown in the above figure B, and may be of glass or metal. Its peculiarity consists in having equal legs, and the lower end of them being turned up. When used, the tube is immersed in water, and thereby filled. It is then lifted up, and one leg immersed in the liquid to be drawn off, and which flows away by the leg which is not immersed. It will be seen how inconvenient this instrument is compared to the other in general application.

SITE. The situation of a building, and sometimes the ground plot or spot of earth it stands on.

SIX'S REGISTER THERMOMETER. This instrument is represented below. It is a spirit of wine thermometer, with a long cylindrical bulb, and a tube bent in the form of a siphon, with parallel legs, and terminating in a small cavity. A portion of the two legs of the siphon from A to B is filled with mercury; the bulb and the remainder of both legs, as well as a small portion of the cavity, are filled with highly-rectified and colored alcohol. The double column of mercury is intended to give motion to two indices C D; the form of which is better shown at E. Each index consists of a bit of iron wire, inclosed in a

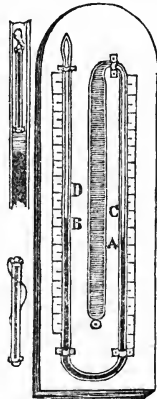

glass tube, which is capped at each extremity by a button of enamel. Their dimensions are such, that they would move freely in the tube, were it not for a thread of glass drawn from the upper cap of each, and inclined so as to press against one side of the tube, forming a delicate spring of sufficient power to retain the attached index, at any part of the tube to which it is driven by the mercury column. When heat expands the spirit in the bulb, it depresses the mercury in the limb A, and proportionably raises it in B, and with it the index; this last remaining fixed at the highest point that the mercury reaches. On the other hand, a decrease of temperature allows the side A to rise, and to carry up also its index; and thus the highest and lowest temperature since the last examination of the instrument is registered. The indices are again brought down to the surface of the mercury, by holding a small magnet towards them.

SIZE. A kind of weak glue, used in many trades. It is made of the shreds and parings of leather, parchment, vellum, &c., boiled in water and strained. The boiling is continued for six or eight hours, and of course the finer the material employed, the more transparent will be the size.

SIZE, Gold. (See *Gold Size*.)

SKELETON. In its common signification, all the bones of a dead animal, dried, cleaned, and disposed in their natural position. The term is, however, applied by mechanics to the principal framing of various things, as the skeleton of a house, which implies merely the walls, rafters, roof, &c., as left from the hands of the bricklayer. A skeleton clock is one which is without the usual case, and so fitted up, that the interior wheel-work is visible. Skeleton keys are thin light keys, with almost the whole substance of the bits filed away, so that they may the more easily escape the opposition presented by the wards in ordinary locks.

SKETCH. In painting, drawing, &c., the first idea of the subject of any given picture.

SKEW-BACK, or ASKEW-BACK. The course of masonry, forming the abutments to a segmental arch, or to the cast iron ribs employed in bridges. The skew-backs in the following cut are shaded.



SKIN. The external membrane of animal bodies.

SKIRTING. A narrow board forming a slightly projecting base to a partition, internal wall, &c.

SKY. The atmosphere, as divested of clouds and vapour.

SKYLIGHTS. Glass frames placed in a roof with one or more inclined planes of glass.

SLAB. An outside plank or board, sawn from the sides of a timber tree, and frequently of very unequal thickness. Also a thin, flat, square piece of marble, or other stone.

SLACKED LIME. (See *Lime*.)

SLAG. Vitriified clinkers.

SLAKE. The saturating of quick lime with water.

SLAKIN. A term used by smelters to express a spongy, semi-vitrified substance, which they mix with the ores of metal to prevent their fusion. It is the scoria or scum, separated from the surface of a former fusion of the same metal.

SLAM. The refuse of alum works, often employed as a manure in combination with seaweed and lime.

SLAP-DASH. A provincial term, more commonly called by builders rough cast. It is a composition of lime, and coarse sand or gravel, reduced to the state of thin mortar, and applied to the exterior of walls as a preservative and ornament.

SLATE. A blueish fossil stone, very soft when dug out of the quarry, and thereby easily cut or sawed into long thin squares, to serve either for tiles for the covering of houses, making tables, &c. Slate for these purposes comes from Caernarvonshire, Westmoreland, and Scotland. The principal kinds of slate are:—1. *Mica* slate, occasionally used for covering buildings, when it appears as large rough pieces. 2. *Clay* slate, the proper slate for the above purpose, and for tables, paving, cisterns, school tablets, &c. 3. *Whet* slate, used as a sharpening stone; one variety of which is known among workmen as *Charley-Forest stone*; another is called *Turkey stone*. 4. *Polishing* slate, used by watch-makers, engravers, &c. 5. *Drawing* slate, or black chalk. 6. *Adhesive* slate. 7. *Bituminous* shale. And 8. *Slate* clay.

SLATT. A thin slab of stone used to cover buildings, distinct from what are called slates, though the latter are used for the same purpose, and have the same name.

SLEDGE. A carriage without wheels, which moves along by a sliding motion.

SLEEPERS. The name of any pieces of wood laid horizontally on the ground, or on brick-work, &c., close or near to the ground, to support a superincumbent weight, or to steady any rails or frame-work. The following shows the usual sleepers used upon railroads, and upon which the chairs for the

rails are fastened. They are about 9 feet long, 5 inches by 9 scantling, and 3 feet from each other:—

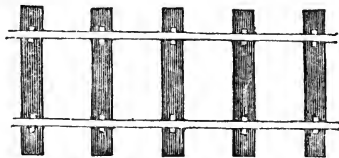

SLEETCH, corrupted into *Slush*. The thick mud at the bottom of rivers.

SLIDE REST. An appendage to a lathe, which differs from the common rest, (see *Rest*.) in this respect, that instead of the tool being held in and guided by the hand, it is made a fixture in the rest itself. It is, however, capable of being moved in several directions. First, backwards or forwards, in front of the work. Secondly, more or less near to it; and thirdly, higher or lower, as occasion may require. An inspection of the cut will show how these motions are obtained. A is an iron foot, with upright socket, which fastens to, and moves along the bed of the lathe, as in the common rest. B is a screw, to fasten the upper part at the requisite height. C C is a piece of steel, 4 or 5 inches long, of the shape represented, with a groove along the middle of it, and graduated on one side in equal parts. The whole of the part D moves backwards and forwards upon C, owing to a micrometer screw at the end of C, and which extends along the whole of the channel, and through a corresponding screw in the side of D; owing to the screw having a micrometer head, it can move D in the most exact and regular manner. In the upper part of D is a groove, in which fits and slides a second slider, and which is at right angles to the first. This has a handle near one end, and a square socket near the other end at E, where the tool is fastened tightly by the screw

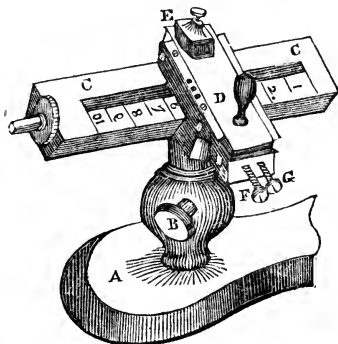

at top. The use of the screws F and G is to adjust the exact degree that the tool shall be allowed to move forwards. A small handle accompanies the micrometer screw, which may be used or not as required.

SLIDING. In mechanics, the motion of a body along a plane, when the same face or surface of the body keeps in contact with the surface of the plane, being thus distinguished from rolling.

SLIP, or LAND SLIP. A falling away of the land on a railroad cutting, precipitous beach, &c., in consequence of being undermined by wet, or other similar causes.

SLIT DEAL. Deals cut into two boards only.

SLOPE. The name given to any inclination, but more particularly to land, whether so formed naturally, or in consequence of being thrown up, or cut away into embankments or excavations.

SLUICE, or SLUICE GATE. A description of sliding shutter made in a lock or flood-gate, that being lifted up the water may pass through, but being closed down the water may be stopped.

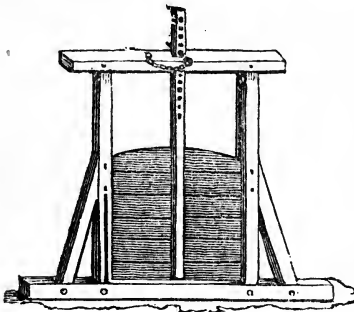

SMALL WARES, is the name given in this country to textile articles of the tape kind, narrow bindings of cotton, linen, silk, or woollen fabric, plaited sash cord, braid, &c.

SMALT AND AZURE BLUE. Glacial oxydes of cobalt, made by fusing zaffre, which is the impure oxyde of cobalt, with glass, or by calcining a mixture of equal parts of roasted cobalt ore, common potass, and ground flints. In this way a blue glass is formed, which, while hot, is dropped into water, and afterwards reduced to a very fine powder. The coarser particles constitute smalt: the finer, azure blue.

SMEATON'S MICROMETER-PYROMETER. The basis of this instrument is of solid brass, which was chosen as of a mean expansibility among the metals. E F is the bar to be measured, resting on two notches; one attached to the fixed upright A B, and the other to the principal lever H I. K is a strong arbor, fixed to the basis, and intended to re-

ceive the ends of the two screws, H L, upon which the principal lever H I turns. O is a slender steel spring, intended to press against the extremity of the bar; and P is a check rod to support the lever when the bar is removed. T is called the feeler; it is in the form of the letter T, and is suspended freely, but without shake, between the points of the screws M N. Q is the handle of the feeler, which is moveable on a loose joint, so that the feeler may be moved by the handle without being irregularly affected by the pressure of the hand. The principal part of the instrument is S the micrometer screw, and W the graduated circle or index plate, fixed on the screw, which indicates the revolutions of the screw on the index V. The micrometer screw passes through two solid heads, perforated by a corresponding screw; the piece Y Z is made somewhat springy, and tends to draw the micrometer screw backwards from D, by which its motion is rendered equable and easy. The instrument is useful to ascertain the expansion of different bodies when heated. Thus immerse the base of the instrument up to the dotted line in water of a known temperature, and mark the effect upon the bar which is placed in the position E F upon the micrometer screw. Taking away this bar, and substituting another of different material, their relative expansibilities can be compared, the water remaining at the same temperature.

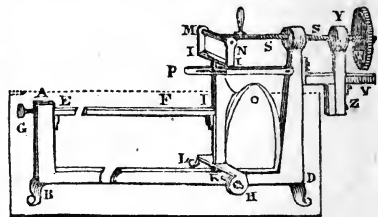

SMEE'S GALVANIC BATTERY. A small but extremely powerful arrangement of galvanic circles. The construction will be understood by the figure, which shows a number of jelly pots, properly connected together.

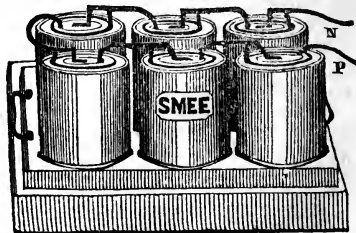

Each jelly pot contains a double ring of zinc, and between these a slip of platina, which

platina is made rough on the surface by depositing upon it also platina, by means of electro-type. This changes the previously-smooth surface into one which is rough, and therefore as far as galvanism is concerned more energetic. Silver leaf, copper leaf, or charcoal, covered in the same way with platina, is equally efficacious. The liquid employed to fill the cells is water with $\frac{1}{8}$ of sulphuric acid. There is no necessity for porous diaphragms between the two metals, though to prevent local action the zinc ought to be amalgamated.

SMELLING SALTS. The sesquicarbonate of ammonia, often improved in scent by an essential oil, as that of bergamot or lavender.

SMELTING. The melting of a metal in a furnace by a blast or reverberating heat, particularly applied to the melting of iron in the first manufacture of it from the ore.

SMILACIN. A vegetable principle peculiar to the *smilax sarsaparilla*.

SMOCKMILL. A windmill, only the top of which turns to meet the wind.

SMOKE. Finely divided particles of carbon thrown off from burning bodies, generally more or less contaminated with oil, tar, acids, or other substances, according to the nature of the material which is on fire.

SNAIL MOVEMENT. A name sometimes given to the eccentric of a steam engine. (See *Eccentric*.)

SNIFTING VALVE. The water which is injected into the cylinder of a steam engine, (as in Beighton's and others,) always contains air, the accumulation of which is prevented by a small pipe with a valve to it, which, when the piston ascends, is kept close by the pressure of the atmosphere, but which, during the downward stroke, opens and suffers the air to escape. This is called the *snifting* valve, because the air makes a noise every time it blows through it, like a man snifting with a cold.

SOAP. A chemical compound of fats or oils with potash or soda, prepared for the purposes of washing. Soaps are of various kinds, all of which come under the denomination of hard soaps or soft soaps; the former being made with soda, the latter with potass. Of the hard soaps, the principal are as follows:—*Yellow* or *rosin* soap, which contains from one-quarter to one-half rosin to the fat employed, either tallow or coarse olive oil. *Mottled* soap, and *white* or *curd* soap—this last is entirely a tallow soap, and neither of them contain any rosin. Of toilet soaps, there are those called *Windsor*, *rose*, *cinnamon*, *musk*, *camphor*, &c., according as they are scented. *Transparent* soap is made by dissolving a hard soap in alcohol, pouring off the clear liquid in proper shaped pans, and allowing it to cool and harden. The *soft* soaps are much used in them manufactures;

they are made with whale, seal, olive, and linseed oils, boiled with strong caustic potass. For the toilet, are used the celebrated shaving soap, called *Naples* soap; also *pearl* soap, and almond cream.

SNOW. A well-known phenomenon, of the same nature as rain, but arising in a freezing atmosphere, whereby the particles of moisture are gradually crystallized, and unite in such a manner together as to form a fleecy or feathery mass of crystals, light compared with hail or rain, yet of sufficient weight to fall to the ground with more or less rapidity. The form of the *flakes of snow* are infinitely varied, yet all partake more or less of an hexagonal figure, some of extreme beauty, as may be seen by the following forms, which are only a few of those depicted by Captain Scoresby, as having been observed by him in the Arctic regions:—

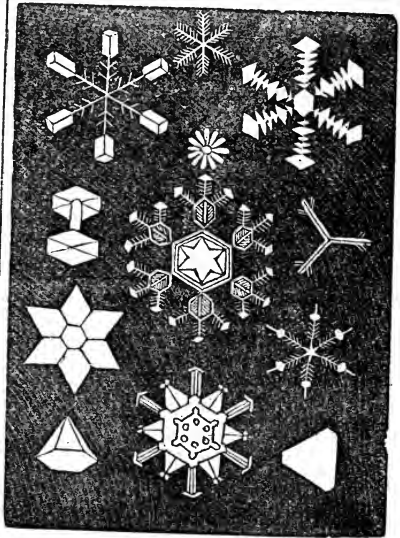

SOAP-STONE. A species of scatite. It imparts to the touch a peculiar feeling, like fine white soap. The soap-stone of this country is chiefly obtained from the Lizard, in Cornwall, where it is found in connection with serpentine, with which it is nearly allied. It is much used in the manufacture of porcelain; also for polishing marble and other stones. It is the basis of various cosmetics, and is combined with carmine or safflower to form rouge; it is also used under the name of French chalk, in taking out grease spots from silks, stuffs, &c.

SOCLE, or ZOCLE. A square piece of masonry, of less height than its horizontal dimensions, serving to raise pedestals, or to support vases or other ornaments; the socle is some-

times continued round a building, or an entire part of a building. It has neither base nor cornice, but is a plain, flat, and unornamented stone, or range of stones.

SODA. One of the fixed alkalis, an oxyde of sodium. It is generally procured from the ashes of marine plants; indeed its great repository is the ocean, soda being the basis of sea salt. Combined with carbonic acid, soda is found in a mineral state in Egypt, where it abounds, under the name of natron, whence it is frequently called the *mineral alkali*. It is a white, brittle mass, of a fibrous texture, of a specific gravity of 1.536; melting at a temperature under that of redness; dissolving readily both in water and alcohol; attracting carbonic acid when exposed to the atmosphere, but hardly any water. It forms soaps with tallow, oils, wax, rosin; dissolves wool, hair, silk, horn, alumina, silica, sulphur, and some metallic sulphurets. It is used in chemical researches; in bleaching; as a detergent; and in the manufacture of soap and glass. That substance, commonly called soda, which is used by laundresses, &c., is in the state of a carbonate. Crude soda is known in commerce by the name of barilla.

SODA WATER. Water impregnated with carbonic acid gas; so called, because frequently made by mixing together, in water, the carbonate of soda and tartaric or citric acid. The union of these produce the solution of a tartrate or citrate of soda, according to the acid used, while the carbonic acid originally in the carbonate, escapes with effervescence, in the state of gas, supposing the vessel uncovered, but if quickly corked up, the gas is retained, and forms aerated soda water. Aerated waters may be, and usually are, made without soda, although the name is still retained. (See the next article.)

SODA WATER APPARATUS, or FOUNTAIN, is an instrument for impregnating water with carbonic acid gas. It may be made of various forms. The following, however, is that which is most usual:—It represents a double fountain, one half of which is for soda water, the other for ginger beer. Suppose K to be the counter of a shop—all above this is only for the conveyance of two pipes to H and I. The lower part of the apparatus may be at any distance, as in an adjoining shed or apartment. A is a cask. Into this is to be put some powdered chalk, and afterwards a little sulphuric acid and water, through the funnel F. The chemical action of these liberate carbonic acid gas from the chalk. This gas passes along the pipe B to another cask C, which has been previously partly filled with water through G. It rises through the water, becoming partly condensed by the water; and partly at a pressure above the water; as soon therefore as the cock I is

turned, the condensed gas in C acts upon the surface of the water, and drives it up the pipe D to H, where it is drawn off. The other side of the apparatus is precisely the same, except that the water in the cask is flavored previously with sugar and ginger.

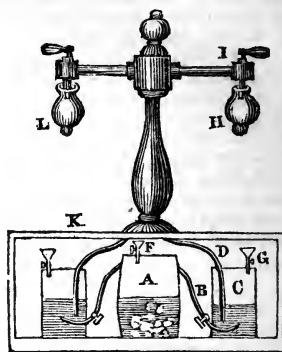

SODIUM. The metallic base of soda. It is white like silver, softer and more malleable than any other metal, and may be readily reduced into thin leaves. It is lighter than water; its specific gravity being .970. It softens at the temperature of 122°, and at 200° it is perfectly fluid. In the air it oxidizes slowly, and gets covered with a crust of soda. When thrown upon water, it is rapidly oxidated, but does not take fire like potassium. There are three oxydes of sodium.

SOFFIT. The ceiling of an apartment, divided by cross beams into compartments; the hollows or pannels being enriched with sculptures or painting. Also the under part of an overhanging cornice or projecting balcony, which may be supported by brackets, &c.

SOFTENING. In painting, the mixing and blending of colors into each other, by which hard outlines, violent contrasts and crudeness, and abruptness of tint, is avoided.

SOFT SOAP. (See *Soap*.)

SOFT SOLDERS. Such as melt at a comparatively small degree of heat. (See *Solder*.)

SOL. The name given to the sun. (See *Sun*.)

SOLANIA. The chemical principle peculiar to *solanum* or night-shade.

SOLAR. Relating to the sun; as solar month, solar year, solar eclipse, &c., for which see the various substantives.

SOLAR MICROSCOPE. This instrument consists of a common microscope, connected to a reflector and condenser; the former being used to throw the sun's light on the latter, by which it is condensed to illuminate the object placed in its focus. One of these microscopes is shown in section below, with

a double object glass E C. The rays from the sun O O O are received on the looking glass or reflector D, which is capable of being directed in any position, to throw the rays of the sun on a condensing lens A. The object I is thus strongly illuminated by the condensed light of the sun. This object is placed in the focus of the microscopic lens C, which in the common instrument is the only one employed; but when the combination of two lenses is used, the magnified image is improved. This representation or picture of the object is received on a wall or screen, and the magnifying power will be always as the distances I C to C A; thus if the acting force of the lens C is 1 inch, when it forms an image on the other side at 5 feet, the linear amplification will be 60 times, or the increase of surface 3600.

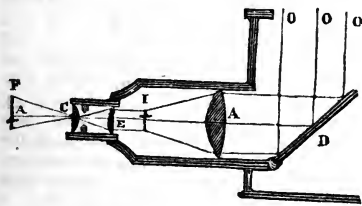

An improved modification of this microscope is shown in the next figure, where R is the reflector. C the condenser. A the object. B the microscope, which is here the compound instrument, (see *Microscope*,) with its eye-piece fitting into the darkened box D, having a concave at the bottom to re-

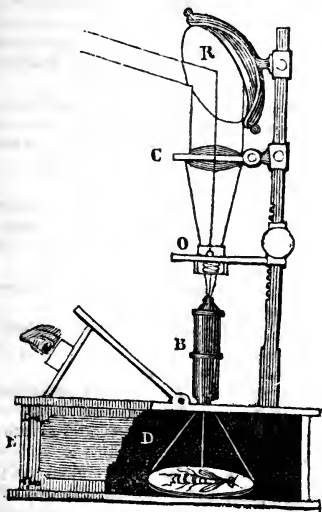

ceive the representation of the object. When it is used for drawing, the front E is let down to admit the hand.

SOLAR RAYS. The particles of light which emanate from the sun. (See *Prismatic*.)

SOLAR SPECTRUM. (See *Prismatic Spectrum* or *Prism*.)

SOLAR SYSTEM. That part of the universe which comprises our sun and the various heavenly bodies which revolve around him. These are the eleven primary planets, their various satellites, and innumerable comets. The most noted hypotheses or systems, which have endeavoured to explain the various motions which take place in the solar system, are those of Copernicus, Tycho Brahe, and Ptolemy; (see these words.) There is reason to suppose that the whole universe is but a continued series of solar systems; each star being a sun, and having its own planets and other bodies attending upon him.

SOLDER. A metallic composition; used in soldering or joining together other metals by fusion. It is a general rule with regard to solders, that they should melt at a lower heat than the metals which are to be united. The solder of the plumber is composed of lead and tin; so also is that used by the tinman, there being about 1 part of lead to 1 or 2 of tin, according to the fineness required. Pewter is soldered by the above, to which a little bismuth is added to render it more fusible. Iron, copper, and brass, are soldered with an alloy of zinc and copper, in nearly equal parts. Silver sometimes with pure tin, but more frequently with silver solder; an alloy consisting of 5 parts of silver, 6 of brass, and 2 of zinc. Platinum is soldered with fine gold. Gold with an alloy of silver and gold, or copper and gold. The copper-smiths solder is made of 8 parts brass and 1 zinc, or else 6 parts brass, 1 tin, and 1 zinc.

SOLDERING. The art of uniting metals together, by fusing between them an alloy or solder. The conditions of soldering are the perfect brightness of the edges to be soldered, a solder which fuses at a less heat than the metal itself, the application of a sufficient heat to melt the solder and not the metal, and prevention of oxidation on the bright surfaces during the operation. The last is effected by laying upon the bright parts either turpentine, as the jewellers do; or rosin, like the plumbers and other artizans. Sal ammoniac is also very serviceable for this purpose.

SOLDERING, Autogenous. A method of joining metals without the aid of what is called a solder. The parts of the metals to be united are brought close together and brightened; then held under a fine jet of burning gas. The intense heat of this, urged as it may be by a blow-pipe, instantaneously melts the metal at the edges, so that the one

times continued round a building, or an entire part of a building. It has neither base nor cornice, but is a plain, flat, and unornamented stone, or range of stones.

SODA. One of the fixed alkalis, an oxyde of sodium. It is generally procured from the ashes of marine plants; indeed its great repository is the ocean, soda being the basis of sea salt. Combined with carbonic acid, soda is found in a mineral state in Egypt, where it abounds, under the name of natron, whence it is frequently called the *mineral alkali*. It is a white, brittle mass, of a fibrous texture, of a specific gravity of 1.536; melting at a temperature under that of redness; dissolving readily both in water and alcohol; attracting carbonic acid when exposed to the atmosphere, but hardly any water. It forms soaps with tallow, oils, wax, rosin; dissolves wool, hair, silk, horn, alumina, silica, sulphur, and some metallic sulphurets. It is used in chemical researches; in bleaching; as a detergent; and in the manufacture of soap and glass. That substance, commonly called soda, which is used by laundresses, &c., is in the state of a carbonate. Crude soda is known in commerce by the name of barilla.

SODA WATER. Water impregnated with carbonic acid gas; so called, because frequently made by mixing together, in water, the carbonate of soda and tartaric or citric acid. The union of these produce the solution of a tartrate or citrate of soda, according to the acid used, while the carbonic acid originally in the carbonate, escapes with effervescence, in the state of gas, supposing the vessel uncovered, but if quickly corked up, the gas is retained, and forms aerated soda water. Aerated waters may be, and usually are, made without soda, although the name is still retained. (See the next article.)

SODA WATER APPARATUS, or FOUNTAIN, is an instrument for impregnating water with carbonic acid gas. It may be made of various forms. The following, however, is that which is most usual:—It represents a double fountain, one half of which is for soda water, the other for ginger beer. Suppose K to be the counter of a shop—all above this is only for the conveyance of two pipes to H and I. The lower part of the apparatus may be at any distance, as in an adjoining shed or apartment. A is a cask. Into this is to be put some powdered chalk, and afterwards a little sulphuric acid and water, through the funnel F. The chemical action of these liberate carbonic acid gas from the chalk. This gas passes along the pipe B to another cask C, which has been previously partly filled with water through G. It rises through the water, becoming partly condensed by the water, and partly at a pressure above the water; as soon therefore as the cock I is

turned, the condensed gas in C acts upon the surface of the water, and drives it up the pipe D to H, where it is drawn off. The other side of the apparatus is precisely the same, except that the water in the cask is flavored previously with sugar and ginger.

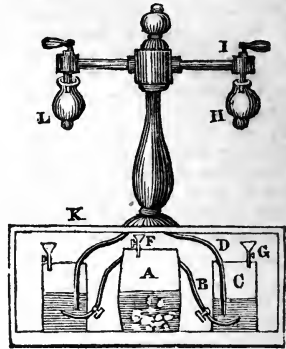

SODIUM. The metallic base of soda. It is white like silver, softer and more malleable than any other metal, and may be readily reduced into thin leaves. It is lighter than water; its specific gravity being .970. It softens at the temperature of 122°, and at 200° it is perfectly fluid. In the air it oxidizes slowly, and gets covered with a crust of soda. When thrown upon water, it is rapidly oxidated, but does not take fire like potassium. There are three oxydes of sodium.

SOFFIT. The ceiling of an apartment, divided by cross beams into compartments; the hollows or pannels being enriched with sculptures or painting. Also the under part of an overhanging cornice or projecting balcony, which may be supported by brackets, &c.

SOFTENING. In painting, the mixing and blending of colors into each other, by which hard outlines, violent contrasts and crudeness, and abruptness of tint, is avoided.

SOFT SOAP. (See *Soap*.)

SOFT SOLDERS. Such as melt at a comparatively small degree of heat. (See *Solder*.)

SOL. The name given to the sun. (See *Sun*.)

SOLANIA. The chemical principle peculiar to *solanum* or night-shade.

SOLAR. Relating to the sun; as solar month, solar year, solar eclipse, &c., for which see the various substantives.

SOLAR MICROSCOPE. This instrument consists of a common microscope, connected to a reflector and condenser; the former being used to throw the sun's light on the latter, by which it is condensed to illuminate the object placed in its focus. One of these microscopes is shown in section below, with

a double object glass E C. The rays from the sun O O O are received on the looking glass or reflector D, which is capable of being directed in any position, to throw the rays of the sun on a condensing lens A. The object I is thus strongly illuminated by the condensed light of the sun. This object is placed in the focus of the microscopic lens C, which in the common instrument is the only one employed; but when the combination of two lenses is used, the magnified image is improved. This representation or picture of the object is received on a wall or screen, and the magnifying power will be always as the distances I C to C A; thus if the acting force of the lens C is 1 inch, when it forms an image on the other side at 5 feet, the linear amplification will be 60 times, or the increase of surface 3600.

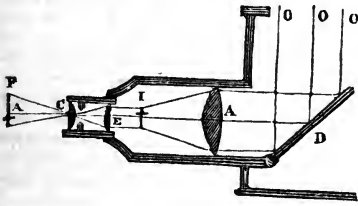

An improved modification of this microscope is shown in the next figure, where R is the reflector. C the condenser. A the object. B the microscope, which is here the compound instrument, (see *Microscope*), with its eye-piece fitting into the darkened box D, having a concave at the bottom to re-

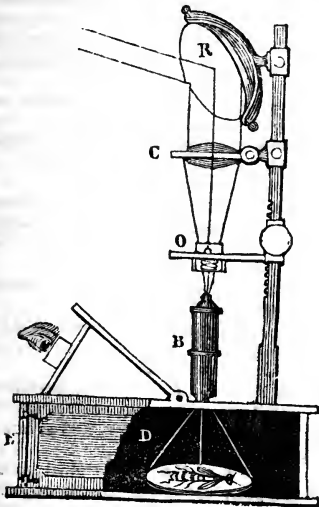

ceive the representation of the object. When it is used for drawing, the front E is let down to admit the hand.

SOLAR RAYS. The particles of light which emanate from the sun. (See *Prismatic*.)

SOLAR SPECTRUM. (See *Prismatic Spectrum* or *Prism*.)

SOLAR SYSTEM. That part of the universe which comprises our sun and the various heavenly bodies which revolve around him. These are the eleven primary planets, their various satellites, and innumerable comets. The most noted hypotheses or systems, which have endeavoured to explain the various motions which take place in the solar system, are those of Copernicus, Tycho Brahe, and Ptolemy; (see these words.) There is reason to suppose that the whole universe is but a continued series of solar systems; each star being a sun, and having its own planets and other bodies attending upon him.

SOLDER. A metallic composition; used in soldering or joining together other metals by fusion. It is a general rule with regard to solders, that they should melt at a lower heat than the metals which are to be united. The solder of the plumber is composed of lead and tin; so also is that used by the tinman, there being about 1 part of lead to 1 or 2 of tin, according to the fineness required. Pewter is soldered by the above, to which a little bismuth is added to render it more fusible. Iron, copper, and brass, are soldered with an alloy of zinc and copper, in nearly equal parts. Silver sometimes with pure tin, but more frequently with silver solder; an alloy consisting of 5 parts of silver, 6 of brass, and 2 of zinc. Platinum is soldered with fine gold. Gold with an alloy of silver and gold, or copper and gold. The copper-smiths solder is made of 8 parts brass and 1 zinc, or else 6 parts brass, 1 tin, and 1 zinc.

SOLDERING. The art of uniting metals together, by fusing between them an alloy or solder. The conditions of soldering are the perfect brightness of the edges to be soldered, a solder which fuses at a less heat than the metal itself, the application of a sufficient heat to melt the solder and not the metal, and prevention of oxidation on the bright surfaces during the operation. The last is effected by laying upon the bright parts either turpentine, as the jewellers do; or rosin, like the plumbers and other artizans. Sal ammoniac is also very serviceable for this purpose.

SOLDERING, Autogenous. A method of joining metals without the aid of what is called a solder. The parts of the metals to be united are brought close together and brightened; then held under a fine jet of burning gas. The intense heat of this, urged as it may be by a blow-pipe, instantaneously melts the metal at the edges, so that the one

edge unites with the other, without the neighbouring parts being injured.

SOLID. In geometry, a magnitude of three dimensions, extended in length, breadth, and thickness. A solid is terminated by, or contained under one or more surfaces, as a surface is by one or more lines; from the circumstance of the terminating lines, solids are either regular or irregular.

SOLID. In physics, is that whose parts adhere to each other with a greater or less force; being thus distinguished from a fluid, whose parts yield to the least external pressure.

SOLID ANGLE, is an angle formed by three or more plane angles meeting in a point, as the angle at the top of a pyramid. (See *Angle*.)

SOLID NUMBERS, are those arising from the product of three prime factors; thus 2, 3, and 5, multiplied together, makes the solid number 30: so $7 \times 11 \times 13 =$ the solid number 1001.

SOLID PROBLEM, is that which cannot be constructed geometrically; namely, by means of right lines and circles, but requires the introduction of some curves of a higher order, as the ellipse, parabola, hyperbola, &c., which being the sections of solids, give rise to the term solid problem; it is not, however, often employed by modern writers.

SOLID OF LEAST RESISTANCE. (See *Resistance*.)

SOLIDIFICATION. The making of any thing solid; thus we say the freezing or solidification of water into ice.

SOLIDITY. In geometry, denotes the quantity of space contained or occupied by a solid body, called also its solid content, being estimated by the number of solid inches, feet, yards, &c. which it contains.

SOLSTICE. In astronomy, that time when the sun is in one of the solstitial points, that is, when he is at the greatest distance from the equator; thus called, because he then appears to stand still and not to change his distance from the equator for some time. The solstices are two in each year, called respectively the summer and the winter solstice. The former is where the sun is in the tropic of Cancer, which is about the 21st of June, being then the longest day. The winter solstice is when he enters the first degree of Capricorn, about the 22nd of December, being then the shortest day. This is to be understood only of the northern hemisphere, it being directly the reverse with regard to the longest and shortest days, and summer and winter, in southern latitudes.

SOLSTITIAL COLOURE. (See *Coloure*.)

SOLSTITIAL POINTS. Those two points in the ecliptic which are farthest from the equator, and diametrically opposite to each other, being the first points of Cancer and Capricorn.

SOLUBLE CREAM OF TARTAR, OR SAL GUMMOSUM, is made by adding 2 parts of borax to 5 of crystals of tartar, in powder, and evaporating the solution to the consistency of honey; it then concretes into the above substance.

SOLUBLE PRUSSIAN BLUE. Prussian blue is only soluble in water when a persalt of iron is added to excess of a solution of ferrocyanuret of potassium. The compound thus formed is soluble in pure water, but not in saline solutions; it consists of 1 atom of ferrocyanuret of potass and 1 of Prussian blue.

SOLUBLE TARTAR. The tartrate of potass; so called in opposition to the bi-tartrate, which is less soluble.

SOLUTION. In mathematics, is the operation whereby the answer of a question or problem is determined. In physics, it is the reduction of a solid to a fluid state, by dissolving it in some liquid.

SOOT. The powdery black mass, deposited by smoke when becoming cool. It is often collected as a pigment, making lamp black and Frankfort black.

SORBIC ACID. The same as malic acid.

SORTANT ANGLE. (See *Angle*.)

SORY. An old name for sulphate of iron.

SOUGH. A small drain, situated at the top of an embankment, for the purpose of conveying the surface water from it into the side drain. The term is also applied to an adit in some parts of the country.

SOUND. A noise or perception of the mind, communicated by means of the ear, being the effect of the collision of bodies, and their consequent tremulous motion, communicated to the surrounding medium, and hence transmitted to the organs of hearing. Sound therefore to be heard requires three conditions. First, a sufficient collision to cause vibration. Second, a medium of sufficient mobility to receive a similar vibration, and consequently to transmit the sound; and thirdly, a certain degree of perfection of the organs of hearing to receive the transmitted impression. Sounds are as various as are the means that concur in producing them; particularly the form, character, and condition of the sonorous body, the rapidity of vibration given to it, and the state of the atmosphere or other medium, which transmits the vibration. The velocity of sound, however, never varies; the rate at which it travels being 1142; or, as some say, 1107 English feet in a second of time.

SOUND BOARD. The same as a canopy over a pulpit, or a part of a musical instrument, placed so as to intercept and reverberate the sound.

SOUTH. One of the four cardinal points of the compass, being that directly opposite the north.

SOUTH POLES. (See *Pole*.)

SOUTHERN HEMISPHERE, LATITUDE, &c. Those on the south side of the equator.

SOUTHING. In navigation, the difference of latitude made by a ship in sailing to the southward.

SPACE. A simple idea, of which the modes are distance, capacity, extension, duration, &c. Space considered with regard to length only is the same idea as we have of distance. If it be considered with respect to length and breadth, or length, breadth, and thickness, it is the same as capacity. When considered between the extremities of matter, which fills the capacity of space with something solid, tangible, and moveable, it is synonymous with extension. Space, therefore, in the general signification, is the same thing with distance, considered every way, whether there be any solid matter in it or not.

SPAN OF AN ARCH. Its width from buttment to buttment.

SPAN ROOF. A roof consisting of two inclined sides or sets of rafters, such as are used to cover ordinary houses.

SPANREL BRACKETING. A cradling of brackets fixed between two or more curves, each in a vertical plane, and in the circumference of a circle, whose plane is horizontal.

SPANRELS. The triangular spaces between the curve of an arch and a square head or dripstone over it. It is usually ornamented with foliage or a shield.

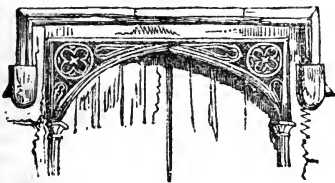

SPANISH BURTONS. (See *Burtons*.)

SPANNERS. A certain portion of some of the old steam engines, the object of which is to catch hold of the tappets on the plug frame, that when this latter is lifted up and down by the action of the engine, they may, by their alternate motion, move the valves to

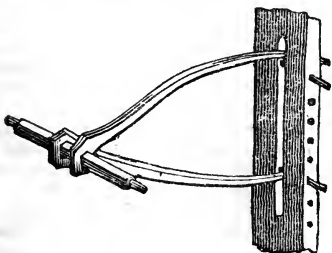

admit or shut off the steam. (See *Beighton's Hand Gear*.)

SPAR. In mineralogy, those minerals that break easily into crystals or laminated fragments with polished surfaces. A spar, among builders, is a large round piece of timber, fit for making masts, yards scaffolding poles, &c.

SPAR, Doubly-Refractive. (See *Carbonate of Lime*.)

SPAR, Fluor, or Derbyshire Spar. The fluuate of lime in a crystallised form.

SPAR, Ponderous. Heavy spar; barytes in the state of a carbonate, as it occurs in many parts of Great Britain, &c.

SPARK, Electrical. (See *Electric Light*.)

SPATULA. A thin knife, used mostly to extend, superficially, some semi-fluid matter.

SPECIES. In algebra, are the letters, symbols, marks, or characters, which represent the quantities in any operation or equation.

SPECIFIC CALORIC. (See *Caloric*.)

SPECIFIC GRAVITY. A comparison of every solid or fluid with the weight of the same magnitude of rain water. Rain water is chosen as the standard of comparison on account of its being less subject to variation in different circumstances of time, place, &c. than any other body, whether solid or fluid; and by a very fortunate coincidence, at least to English philosophers, it happens that a cubic foot of rain water weighs 1000 ounces avoirdupoise, and consequently assuming this as the specific gravity of rain water, and comparing all other bodies with this, the same numbers that express the specific gravity of bodies, will, at the same time, denote the weight of a cubic foot of each, in avoirdupoise ounces, which is a great convenience in numerical computations.

SPECTACLES. An optical instrument, consisting of two lenses set in a frame, and applied on the nose to assist in defects of the organs of sight.

SPECTACLES, PERISCOPIC. (See *Periscope*.)

SPECTRA, OCULAR. The same as accidental colors, (which see.)

SPECTRUM. In optics. (See *Prism*.)

SPECULUM. The same as a mirror. (See *Mirror*.)

SPECULUM METAL. An alloy adapted for making the specula of telescopes, &c. It is composed of 6 parts copper, 2 tin, and 1 arsenic.

SPERMACETI. A substance obtained from the oil found in the head of several species of whale, but chiefly from the *Physeter macrocephalus*. An ordinary-sized whale will yield, it is said, upwards of twelve large barrels of crude spermaceti. The chief employment of spermaceti is for making candles and ointments.

SPHERE, or GLOBE. A ball or solid, whose surface is everywhere equally distant from a certain point within the solid, which point is called the centre of the sphere.

SPHERE. In astronomy, that concave orb or expanse which appears to invest our globe, and in which all the heavenly bodies appear fixed. This is also called the sphere of the world, and is the subject of spherical trigonometry. The sphere as it relates to the fixed stars being immensely great, the spectator always judges himself in the centre, and the calculations made on this supposition deviate not in the least sensible degree from the truth.

SPHERE, Armillary. (See *Armillary*.)

SPHERE, Direct or Right, is that which has the poles of the world in the horizon, and the equator in the zenith and nadir. An *oblique* sphere cuts the horizon obliquely: in a *parallel* sphere the poles are in the zenith and nadir, and the equator coincides with the horizon.

SPHERE, Circles of. (See *Circle*.)

SPHERE OF ACTIVITY OF A BODY, is used to denote the space through which the influence of any body, as a magnet, &c. extends.

SPHERICAL. Relating to a sphere.

SPHERICAL ABERRATION. (See *Aberration*.)

SPHERICAL BRACKETING. The forming of brackets to support lath and plaster work, so that the surface of the plaster shall form the surface of a sphere.

SPHERICAL POLYGON. A figure of more than four sides, formed on the surface of a sphere by the intersection of several of its great circles.

SPHERICAL VALVE. (See *Ball Valve*.)

SPHERICITY. The quality of a sphere, or that by which a thing becomes spherical.

SPHERICS. The doctrine of the sphere, particularly of the several circles described on its surface, with the method of projecting the same on a plane.

SPHEROID. A solid somewhat resembling a sphere, differing from it however in not having every part of the surface equi-distant from the centre; but yet if one diameter of it be taken as an axis, the surface perpendicular to that axis will always be a circle. Spheroids are *irregular* or *universal*, as an egg; or *regular*, when they are called oblate, and oblong or prolate; according as they may differ from a true sphere in being broader than long, like an orange; or longer than broad, like a lemon.

SPHEROIDAL, or SPHEROIDICAL. Having the form of a spheroid.

SPHEROIDAL BRACKETING. The bracketing prepared for a plaster ceiling, whose surface is to form that of a spheroid.

SPHERULE. A little globe or sphere.

SPIDER, ELECTRICAL. A small ball of pith, cut of the size, and into the form of a

spider, suspended by a long filament of silk, and with eight linen thread legs. When this is held between the knob connected with the inside of a Leyden jar, and a ball connected with the outside, (as shown in the cut,) or otherwise, as may be most convenient, and the bottle or jar has been charged by an electrical machine, the spider will pass alternately from one ball to the other, until by the conveyance of the accumulated fluid from the inside of the bottle to the outside it will be discharged.

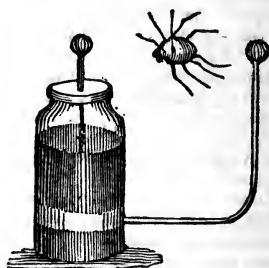

SPINDLE. In geometry, as a solid, is a circular body, tapering towards both ends; as a superficies, it is flat, tapering also at both ends. The same as would be caused by two equal arcs of equal circles, meeting each other, so as to inclose the greatest space possible.

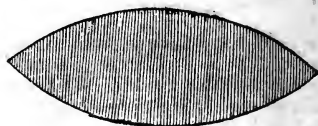

Spindle, in mechanics, is a thin arbor, by which to connect together wheel-work, to support wheels in their requisite position, &c. &c. In weaving, it is a thin piece or bobbin of wood or steel, on which yarn, linen, &c., is wound after it has been twisted.

SPINNING. The art of combining vegetable fibres into threads, by twisting them together, as in cotton, silk, wool, flax, hemp, &c.

SPIRAL. A curved line, of a circular form, which in its progress always recedes more and more from a point within, called the centre. There are various kinds of spirals, namely:—The spiral of Archimedes, the logarithmic spiral, the loxodromic spiral, the parabolic spiral, &c., according to the law by which the point recedes from the centre. The *Archimedian* spiral is generated by supposing the arc of a circle to be divided into any number of equal parts in P P P P, &c.; then radii being drawn from the centre to these points,

divide one of them into the same number of equal parts, and make CM, CM, CM, &c., equal to 1, 2, 3, &c., of these parts; and the line drawn from the centre passing through these several points will be the spiral of Archimedes. It differs from the logarithmic spiral in this, that here the distances CM are in arithmetical progression, but in the logarithmic spiral in geometrical progression.

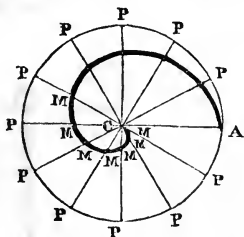

It is particularly called the first spiral when it has made one revolution to the point A, and the space included between the spiral and the radius AC is called the spiral space. The first spiral may be continued to a second, by describing another circle with a radius double that of the first, and continuing proportional divisions as before. This spiral may be made mechanically by winding a thread round a pencil, ruler, or other cylinder. On gradually unwinding it the loose end will describe the spiral. The *hyperbolic* or *reciprocal* spiral is as follows:—If from one of the extremities C of the right line FC as a centre, with the distances CD, CE, CF, &c., as radii, a number of arcs DEFGH be described, so as to be all equal in length to each other, the curve CKLMN drawn through the extremities is called the hyperbolic or reciprocal spiral, of which the line CF is called the axis, and the point C the centre.

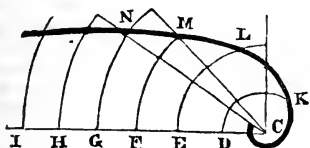

For the *logarithmic* spiral, see *Logarithmic*; and for the *loxodromic* spiral, see *Rhumb*. The *spiral of pappus* is a spiral formed on the surface of a sphere, in the same manner as that of Archimedes is on a plane. A *natural* spiral is constructed in the same manner as the Archimedean, with the difference that it is traced upon the surface of a cone. This kind of spiral is seen on many screws; for example, the gimlet point.

It is also the spiral which is so common on the shells of fish and snails, as the whelk, periwinkle, &c. The *parabolic* or *helicoid* spiral is a curve arising from a supposition of the common parabola being bent round into the periphery of a circle. If, for instance, the axis of a parabola be bent into the periphery of the circle BDM, then the curve BEGNA which passes through the extremities of the ordinates CE, DG, &c., which converge towards the centre of the circle A, will constitute the curve, which is called the *helicoid* or *parabolic* spiral.

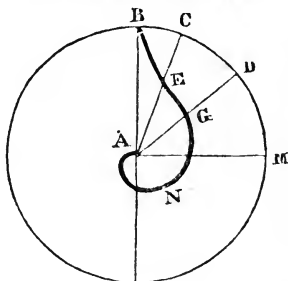

SPIRAL, Electro-Magnetic. (See *De Rive, Sturgeon, &c.*)

SPIRAL PUMP. (See *Archimedes Screw.*)

SPIRAL TUBE. An electrical apparatus to show that the electric fluid, although passing invisibly through or over conducting substances, yet becomes visible when an interruption in those conducting bodies takes place. The spiral tube consists of two glass tubes, one fitting within the other; on the outside of the inner tube a spiral line of spangles of tin-foil is pasted—they being placed so as very nearly to touch each other. A brass ball at each end secures the tubes together. When one ball is held in the hand, and the other made to approach the prime conductor of an electrical machine, a spark will run along the tube and be visible at every interval between the spangles. When a number of these tubes are placed upon a stand, a rapid succession of sparks may be given to each in rotation, by means of a central piece A and B. A is a brass wire terminated by two balls, and poised by a pin at the centre. B is a glass rod with a brass cap and socket at top to support A. When this brass cap is connected with the machine, and A is made to turn round by the finger, each time one of its balls comes in contact with the balls on the top of the spiral tube, a spark will be given off and run



down the tube. This instrument is called the *set of spirals*, and is represented beneath.

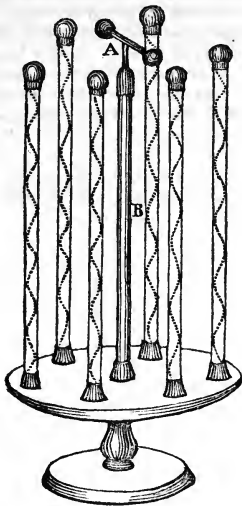

SPIRE. A long pyramid erected upon the lantern of a tower, mostly polygonal or square, rarely round; often called a steeple.

SPIRIT BLOW-PIPE. (See *Alcoholic*.)

SPIRIT LAMP. Any small lamp which is fed by spirits of wine, or pyroacetic spirit, rather than by oil, producing a large and hot flame, though little light and no smoke; the lamp being used in chemical operations, to heat retorts, test tubes, &c., and not for the light it affords. Spirit lamps are usually made of glass, with a brass top to hold the wick, and supplied with a cover, which fits over the top when it is desirable to extinguish the flame.



SPIRIT LEVEL. (See *Level*.)

SPIRIT OF MINDERERUS. A solution of acetate of ammonia; made by adding concrete carbonate of ammonia to distilled vinegar till saturation takes place.

SPIRIT OF NITRE. Nitric ether.

SPIRIT OF SAL AMMONIAC. Liquid ammonia.

SPIRIT OF SALT. Hydro-chloric, formerly muriatic acid.

SPIRITS OF TURPENTINE. A highly inflammable and strongly smelling liquor, obtained by the distillation of turpentine.

SPIRIT OF WINE. Alcohol.

SPIRIT, Pyroacetic. (See *Acetone*.)

SPIRIT, Rectified. (See *Alcohol*.)

SPIRIT, Sulphuretted. A liquid obtained by passing a current of sulphuretted hydrogen through an aqueous solution of ammonia. It is indifferently called the hydro-sulphuret of ammonia, hydro-sulphate of ammonia, Boyle's fuming liquor, and Beguin's sulphuretted spirit.

SPIRIT, Vinous. Alcohol.

SPIRITUOUS LIQUORS. Such as contain alcohol, and which therefore are the result of fermentation, with or without being afterwards concentrated by distillation; such as beer, wines, gin, rum, brandy, cider, &c.

SPLAY. A sloping surface, as windows of Gothic buildings are splayed inwards; the mullions of a window are often splayed or parged off.

SPLICE. To conjoin lengthwise two flexible pieces by the interposition of their respective parts, so as to maintain them in conjunction by friction.

SPOIL, or SPOIL BANK. The surplus earth thrown up on the side of an excavation, placed there for no particular use, but merely to save the expense of removal.

SPOKES. The radial pieces which connect the periphery of a wheel with its centre-piece or nave; this term is only applied to carriages.

SPONGY PLATINUM. The metal platinum in a state of minute sub-division.

SPORADES. A name given by the ancients to those stars that were not included in any of the constellations.

SPORTSMAN, Electrical. An amusing and ingenious instrument, to illustrate the fact that a charged electrical jar will discharge itself if the outer and inner coating approach too closely. The inner coating of the Leyden jar is connected with two wires, one of which proceeds to the birds, (these are small pieces of pith, with feathers for wings, and attached to 4 or 5 inches in length of a fine linen thread;) the other wire proceeds to within a small distance of the muzzle of the gun.



The gun is connected with the outer coating of the phial by means of the wire proceeding,

from it to the figure, and a slip of tin-foil, which is pasted along the figure to the muzzle. Connecting the phial with the electrical machine in action, it will, of course, become charged, during which time the birds will elevate themselves by electrical repulsion; when the bottle is charged to a certain extent, the distance between the muzzle of the gun and the ball near it will not be sufficient to restrain the passage of the fluid, which will therefore pass between them, occasioning at the same time a flash of light, a loud report, and the falling of the birds.

SPOTS. In astronomy. (See *Facule* and *Macule*.)

SPRING. In natural philosophy, is a fountain or source of water rising out of the earth, and yielding a supply more or less constant, according to different circumstances. Those which run continually are called *perennial*; while such as run only for a time, and at certain seasons of the year, are called *temporary* springs. Others again are called *intermittent* springs, because they flow and then stop, and flow and stop again; (see *Intermittent*.) And finally, *reciprocating* springs, whose waters rise and fall, or flow and ebb at regular intervals.

SPRING. In mechanics, is used to denote any thing which is perfectly elastic. The following is one of a spiral form, of common use in watch and clock-work. It possesses very considerable power and long continued action in a small space:—

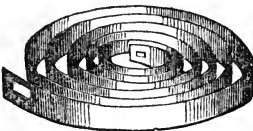

SPRING. In astronomy, that season of the year in which the sun passes through the three first signs of the zodiac, Aries, Taurus, and Gemini, extending from the time of the vernal equinox, or the 21st of March, to the period of the summer solstice, or the 21st of June. During this period the sun's declination is north, and continually increasing, consequently his meridian altitude, the length of the days, and the warmth of the weather increases also.

SPRING, Strength or Force of, is used for the force or weight, which when the spring is wholly compressed or closed will just prevent it from unbending itself; also the force of a spring partly bent or closed, is the force or weight which is just sufficient to keep the spring in that state by preventing it from unbending itself any farther.

SPRING ARBOR. The arbor or spindle

round which the main spring of a watch is turned.

SPRING BOX. The box in which the main spring of a watch is contained.

SPRINGERS. The two first stones of an arch, one above each impost.

SPUR GEAR. Wheels whose axles are parallel to each other, that is, those wheels the teeth of which are perpendicular to their axles.

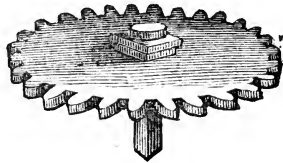

SQUARE. In geometry, is a superficies inclosed by four equal sides, and having the four angles of it right angles, and consequently equal. As an adjective, it is any thing the section of which would be a square or part of a square.

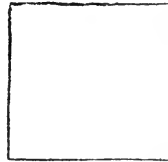

SQUARE. Among workmen, is a term applied to any material when two of the sides stand perpendicular to each other; also an instrument for trying whether an angle be a right angle or not.

SQUARE, Magic. (See *Magic*.)

SQUARE-FRAMED. Among joiners, signifies work which has all the angles of its styles, rails, and mountings square, without being moulded.

SQUARE NUMBER, is the product arising from a number being multiplied by itself, or a number formed of two equal factors; therefore 64, 36, and 25, are square numbers, being produced by the multiplication of 8 by 8, 6 by 6, and 5 by 5. We consequently call 64 the square of 8; 36 the square of 6; and 25 the square of 5.

SQUARE ROOT. (See *Root*.)

SQUARE STAFF. A piece of wood used for fortifying the angles of plaster-work intended to be papered over.

SQUARING A MATERIAL. The cutting it into a square or rectangular form.

STAFF. A thick round stick; the upright pieces of wood which form the front of a hay rack are called staffs, and so are the teeth of a trundle.

gradually screwing it up, cuts the edge of the paper or book with an even surface.

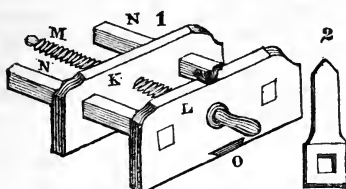

STATIONER'S, or BOOKBINDER'S SEWING PRESS. This is very erroneously called a press, its use being merely to keep a book steady, while the several sheets of it are sewed together. B B are two upright screws, fastened to a base board A A, which has a channel cut along, and through it, towards the front edge and between the screws. C is a cross bar, fitting loosely on B B, and supported at any required height by the two nuts D D. When a book is to be sewed, strings are fastened to the cross bar C, brought through the channel of the base board, and confined underneath by small pins. The sheets of paper are folded, pressed, knocked so as to be level at the back and top edge, put in the cutting press, screwed up, and with a small toothed saw, several grooves for the string and thread are cut transversely across the back, all but the two end ones having a string for it. The first sheet of paper is taken, the strings adjusted to the saw cuts; a needle and strong thread is entered at one of the terminal cuts, where there is no string, passed within the sheet, out at the next cut, across the first string; into the sheet again at the second string, out at the third, and so on to the end cut, where there is no string. It is, therefore, made immediately to pass into the next sheet of paper, and passing along it in like manner is finally fastened to where it first entered the first sheet, thus connecting both sheets together. The process is continued until the whole number of sheets are connected.

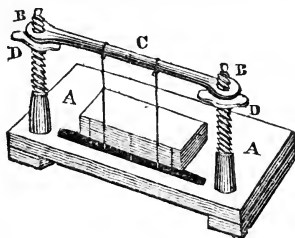

STATUE. A solid representation of a human form, free and unconnected with any building. The size of statues, among the ancients, was dependent upon the use to

be made of them, and the person represented. First, those smaller than life were mostly carved in wood, or cast in bronze, and kept as moveable ornaments, or as relics in houses; such were the penates or household gods. Second, of natural size, made to perpetuate the memory of some renowned individual; the deities were sometimes of this size, as the Apollo Belvedere, and the Venus de Medicis. Third, statues half as large again as life, representing emperors. Fourth, twice as large as life, to celebrate heroes, such as the Falernian Hercules. Fifth, of a yet greater size, called colossi, to represent the gods; for example, the statue of Minerva, within the Parthenon; the Colossus of Rhodes, &c.

STATUARY. In a general sense, the art of casting statues; also a statue or a group of statues. The Laocoon is a fine example of the latter; as are also many of the monuments within St. Paul's Cathedral—the death of General Abercrombie for example.

STATUARY MARBLE. Any marble adapted to the use of the statuary.

STAVES. Any long narrow pieces of wood that are braced together side by side, for the formation of a cask, a hollow cylinder, cone or conoid, or any frustrum of these bodies.

STEAM. The name given to the visible moist vapour, which arises from all bodies that contain juices easily expelled from them by heats not sufficient for their combustion. Thus we say, the steam of boiling water, of malt, of a tan bed, &c. It is distinguished from smoke by its not having been produced by combustion, by not containing any soot, and by its being condensed by cold into water, oil, inflammable spirits, or liquids composed of these according to the substance it arose from; the steam from fermented liquors being condensable into a spirituous liquid, that from coal tar yielding naphtha, and that from water turning to water again. It is the latter kind, indeed, that is usually understood to be implied when steam is alluded to, and it is this which is applied to such numerous purposes of steam machinery and engines, and as the means of supplying heat to various bodies. Steam possesses great elasticity when confined; it also has a great degree of latent heat, which it readily gives out to surrounding bodies. Steam, when rising from water in an open vessel, is only able to counteract the downward pressure of the atmosphere, or but little more; it is then called *low pressure steam*; but if the water whence it arises is contained in a close vessel, as steam is constantly generated, without having the power to pass off, it soon accumulates and obtains a proportionately greater power. It is then called *high pressure steam*.

STEAM BOAT. Any boat, the impulse of which is derived from the power of steam.

acting upon an engine, connected with paddle wheels attached to the sides of the vessel.

STEAM CARRIAGE. Any carriage or land vehicle which is worked by steam, and carries passengers or goods. This latter circumstance distinguishing it from a locomotive engine, which draws other carriages after it.

STEAM Cylinder, Chest, Case, Jacket, Valve, Cock, &c. &c. Portions of various apparatus for the containing or the conveyance of steam.

STEAM ENGINE. A machine wrought by the force obtained from the expansion and contraction of the steam of boiling water, and employed as a first moving power to other machines. All steam engines consist of two distinct parts, necessarily connected together; these are, the *boiler*, in which steam is generated, and the *engine*, properly so called, where it is applied to produce motion, and where it is condensed. Steam engines are divided into *stationary*, *marine*, and *locomotive*, into *low pressure* or *atmospheric* engines, and *high pressure* engines, and are often known by the purposes to which they are applied, the principle involved in their structure, or the name of their inventor; thus we have, as applied to them, the terms *cylinder*, *beam*, *bell-crank*, *rotatory*, *pumping*, *stamping*, *Savary*, *Newcomen*, &c. The history and progress of this noble implement of manufacture, draining and locomotive, may be traced by turning to the names of the various inventors, in the following order, the dates of invention being annexed:—*Æropile* and *Hero's Fountain*, 130 years B. C.; *De Caus*, 1615; *Branca*, 1629; *Worcester*, 1763; *Savary*, 1698; *Newcomen's*, or the atmospheric engine, 1705; *Papin*, 1707; *Desagulier*, 1716; *Bighton*, 1718; *Leupold*, 1720; *James Watt*, 1765; *Cartwright*, 1782; *Cooke*, 1786; *Francois*, 1791; *Murdock*, 1799; *Nuncarrow*, 1799; *Trevithick* and *Vivian*, 1802, (this is a locomotive engine); *Boaz*, 1805; and *Masterman*, 1822. The particulars of an ordinary steam engine boiler are already given under the word *Boiler*. The usual parts of the engine itself are, perhaps, best shown by Watt's double-action engine, figured in the section beneath, where A is the steam-pipe conveying the steam from the boiler into the cylinder B, by means of the slide valves C; D is the condenser; E the air-pump, the rod of which is connected with the working beam P; F the injection cock; G the cold water cistern; H the hot water cistern; I a jacket, called a steam jacket, to inclose the cylinder, and by keeping its exterior warm to prevent condensation in that part; K is the piston rod; I the parallel motion; M the governor connected with the throttle valve in the steam pipe;

N the hot water pipe for the supply of the boiler by means of the pipe Q; O the cold water pipe to supply the cold water cistern; P the working beam; R the crank beam; S the fly-wheel. The valves are worked by tappets on the air-pump rod, as at T. The principle of these parts are described under their respective names. (See *Cylinder*, *Condenser*, *Governor*, *Valve*, &c.)

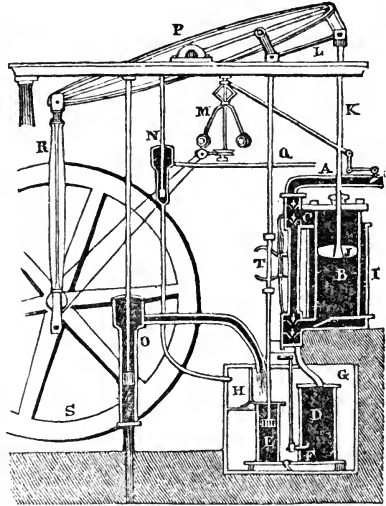

STEAM GAUGE. (See *Gauge Cocks*.)

STEAM PIPE. The pipe communicating with the upper part of the steam engine boiler, through which the steam passes in its passage to the cylinder.

STEAM TIGHT, denotes such a degree of closeness as prevents the escape of steam.

STEAM WHEEL. A rotatory steam engine, such as are described under the words *Cooke* and *Cartwright*.

STEAM WHISTLE. A device attached to locomotive engines for giving warning when the engine is starting or approaching the terminus. It consists of a pipe situated at the top of the boiler, with a cock to the same, within reach of the engine man, who is thus enabled to turn off or on the steam at pleasure. When turned on, it issues through the pipe into a hollow cup, passing through four holes in a plate placed at the bottom of it; the steam then escapes at the top, round the thin edge of the cup, and striking it with considerable force, produces a loud shrill whistle, which can be heard at a distance of many miles.

STEARIC ACID, otherwise called **STEARINE.** The solid constituent of fatty substances, as of tallow and olive oil, converted

into a crystalline mass by saponification with alkaline matter, and abstraction of the alkali by an acid. By this process fats are converted into three acids, called stearic, margaric, and oleic; the first two being solid, and the last liquid. The solid acids are separated from each other by washing them in alcohol, which holds the margaric acid in solution after it has deposited the stearine in crystals. These are of a pearly whiteness, insipid, and inodorous; insoluble in water; of a needle-like form, and grouped together. Beautiful candles are often made from stearic acid.

STEARONE. When stearic acid is distilled with a fourth part of quicklime, a substance is obtained sparingly soluble in ether and alcohol; concrete at common temperatures, but fusible at 180° . This is called *stearone*.

STEATITE. (See *Soap Stone*.)

STEEL. A compound of iron and carbon; made by placing bars of iron, surrounded by charcoal powder, in a box of fire-stone, covering the layers of iron and charcoal, with sand, and placing the whole in a strong oven or furnace. These are kept in a red hot state for eight or ten days. This process is called *cementation*. The bars of steel formed in this way are raised in many parts into small blisters; on this account steel made thus is called *blistered steel*. The bars of blistered steel are heated to redness, and drawn out into smaller bars by means of a hammer, called a tilting hammer; on which account the bars made by it are called *tilted steel*. When the bars are broken in pieces, welded repeatedly, and then drawn out into bars again, they acquire the name of *German* or *shear steel*. Blistered steel is never quite equable in its texture, but it is rendered quite so by fusing it in a crucible, and then casting it into bars; thus treated it is called *cast steel*. It is used chiefly for edge tools, and other cutting instruments, for the rubbing parts and points of machinery; and from the fine polish of which it is susceptible, its applications to ornamental, as well as useful purposes, are as obvious as they are well known.

STEEL, Gilding of. Delicate steel instruments, painted with or dipped into an ethereal solution of chloride of gold, become covered with a bright surface of the latter metal. In this way swords, &c. are gilt.

STEELYARD. A kind of balance, called also *statera Romana*, or the Roman balance, by means of which the weights of different bodies are discovered by using one weight only. The common steelyard consists of an iron beam, B C, resting upon knife edges or a pivot, and having one arm, B C, much longer than the other D G; yet the end G being large and heavy, it with the proper scale attached exactly balances the long arm

E C. On the long arm slides a moveable hook E, and weight P. Equilibrium is established, or in other words the weight of any thing placed in the scale W is ascertained by moving the weight P backwards and forwards, until it acquires such a leverage that the beam is horizontal, and as the long arm is graduated from E to B the weight is immediately seen upon the scale.

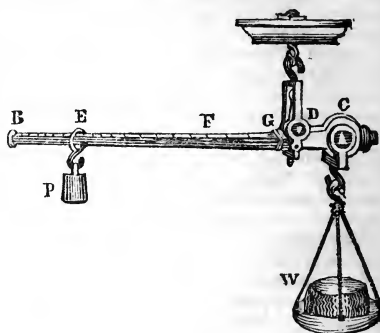

STEELYARD VALVE. (See *Safety Valve*.)

STEEPLE. Any part of a church above the roof. It may be a tower only, or a tower and spire.

STENCILLING, OR ORIENTAL TINTING. A method of producing the picture of an object without drawing it. The method is as follows:—Suppose a heart's-ease flower is to be represented; lay a piece of thick transparent paper over it, and with a pencil trace round such parts of it as are to be blue; for instance, the upper petals and three spots on the lower ones. Then at a little distance trace the lower or yellow petals, and on a separate part of the paper, the green leaves and the stem, in the manner represented; taking care that different colors do not run into each other: Cut out all these places, then lay the blue part over a sheet of white paper, and rubbing the proper colors on a pallet, take up a little with a stiff, short-haired brush, and rub it on the holes appertaining to the blue petals; the color will of course be left on the paper below. Then change the position of the *guide paper* for the yellow petals, and placing it carefully, rub on with another brush a yellow color; afterwards, in like manner, the green color for the leaves. This being done, the flower will be complete and effective, in proportion to the care bestowed upon it. The walls of rooms are often stencilled in this manner, but with little care, and more rapidity than can be used with delicate objects. The following cuts show the guide, and the figure of the object made by putting its various holes in a proper juxta-position. The black parts are

to be considered as holes cut through a piece of thick transparent paper.

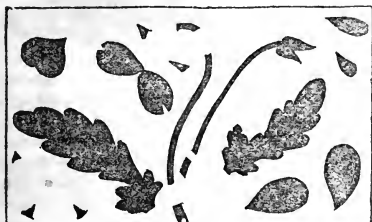

STEPS. The various lifts or degrees of a staircase, by which we ascend or descend; divided into *treads*, or the portion trodden upon; and *risers*, which are those parts that elevate the treads above each other.

STEPS, or BEARINGS. In engineering, those parts that receive the lower gudgeons of upright shafts.

STEREOBATE. An old word synonymous with the modern socle.

STERO-ELECTRIC CURRENT. (See *Thermo-electric Current*.)

STEROGRAPHY. That branch of solid geometry which demonstrates the properties, and shows the construction of all solid bodies which are regularly defined. It also explains

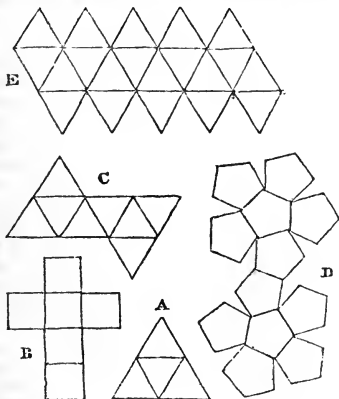

the methods for constructing the surfaces in planes, so as to form the entire body, or to cover the entire surface of the solid. As an example, the five regular bodies (see *Bodies*;) may be formed by cutting paper or card of the various forms represented in the cut, when folding them up their edges will coalesce, and the required solid be formed. A is the tetrahedron; B the cube; C the octahedron; D the dodecahedron, and E the icosahedron.

STEREOTYPE. The art of casting solid plates from moveable types, in order that the former may be used at a future time, instead of incurring the expense of recomposing or resetting the type. The process of stereotyping is as follows:—The page (or pages) of type are laid back downwards on a smooth horizontal surface, and either oiled, or preferably rubbed over with black-lead. It is then surrounded with a brass edge or frame, plaster of Paris is mixed with water and poured upon it, so as to make a cast of the type; this, when set, is taken off and dried in an oven. When dry, each cast is laid with the impression downwards, upon a flat cast iron plate, called the floating plate, this plate being itself laid on the bottom of the dripping pan, which is of cast iron; a lid is put upon thin and secured in its place by a screw. The pan having been heated to 400° in the oven, previous to receiving the mould, is ready to be plunged into the bath of melted alloy, contained in an iron pot placed over a furnace; into this it is dipped, and as there is a small space between the cover of the dripping pan and the top of the floating plate, the hot metal running in at the corners, lifts up the mould and flows freely into all its interstices. When full, it is taken out and placed with its bottom touching a surface of water. The metal thus congeals at the bottom first; metal is poured in to allow for shrinking in cooling, and produce a fine impression. The pan being taken asunder, the compound cake of metal and mould is taken out, and beat upon its edges with a wooden mallet to detach the superfluous metal. The stereotype plate is then handed over to the picker, who planes its edges truly square, turns its back flat in a lathe to a determinate thickness, and carefully removes any imperfections which may have arisen from dirt or air left in the letters, &c.

STEREOTYPE METAL. An alloy for the casting of stereotype plates, consisting of 9 lbs. of lead; to which, when melted, are added 2 lbs. of antimony and 1 lb. of bismuth. This alloy expands as it cools.

STERLING, Standard or Guinea Gold, consists of 11 parts of pure gold and 1 of copper.

STIBIUM. Antimony.

STICK LAC. Lac or lac resin, which still adheres to the sticks or twigs of the tree from

which it has exuded. It is of coarser quality than shell lac.

STILLE. (See *Style*.)

STILL. A chemical apparatus, for vaporizing liquids in one part, called by chemists the *cucurbit*; and condensing the vapors in another part, called the *refrigeratory*. The general purpose of both combined being to separate the more volatile fluid particles for those that are less volatile. In its simplest form it consists of a retort and a receiver, or

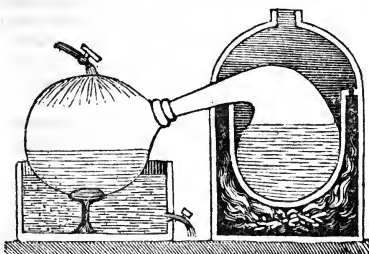

of a pear-shaped alembic or matrass, and head, furnished with a slanting tube for conveying away the condensed liquid in drops; whence the term still, from *stillare*, to drop.

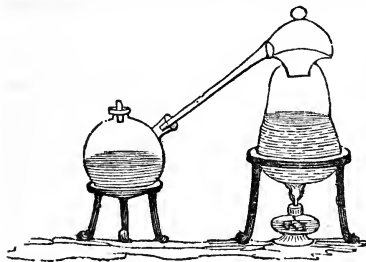

Stills like the above are used for the making of various oils, acids, and other liquids, in small quantities; for the purposes of manufacture, particularly of ardent spirit, a larger apparatus is necessary. The following is the still used by the distiller:—

B is the still itself, which is like a copper with a contracted top, set in brick-work, and with a fire-place beneath. C is the head and neck of the still, which fits tightly on to the body of it. E the end of the neck, where the head unites to the worm. F the worm tub, containing the worm or refrigerator. (See *Worm*.) G the cock, supplying cold water to condense with. Impure spirit being placed in B, it is made to boil. The steam from it rises, passes over the head into the worm, and around the various coils; being condensed, and more and more cooled in its passage, until it issues in a stream from the lower end of the worm, becoming

by this process a purer and stronger liquid than when first put into the still.



STILL LIFE. In painting, the representation of inanimate objects, such as dead animals, sometimes with fruit and flowers in addition. The interest of such representations can consist only in the form, grouping, and light; hence the pictures of still life belong to the lowest description of painting.

STILLYARD. (See *Steelyard*.)

STIPLING. A mode of engraving on copper or steel, or painting on paper, by means of dots, as contradistinguished from a course of continued lines. The term is likewise applied to the mode adopted by some artists, in drawing, of putting in the tints and shadows of black lead or crayons, by means of the end of a piece of coiled paper or leather, (called a stump,) charged with the pigment with which it is stippled or stamped on to the surface of the paper.

STOCKS. A frame erected on the shore of a river or of the sea; and in large establishments in the inside of docks, for the purpose of building ships. It generally consists of a number of solid wooden blocks, ranged parallel to each other, at convenient distances, upon a very firm foundation, and with a gradual declivity towards the water.

STOICHIOMETRY. That branch of chemical knowledge which treats of the proportions that substances must have when they enter the state of neutrality; that is, when they counteract each other's effects.

STONES. Mineral bodies; hard, insipid, not either ductile, malleable, metallic, or soluble in water. Used for almost endless purposes of ornament, paving, building, polishing, grinding, slating, road-making, &c. Stones are usually divided into three heads; the *siliceous*, or those formed of silex, which are the hardest and least liable to decay, comprising granite, sand-stone, &c. Second, the *argillaceous*, or those composed of clay, which class comprehends basalt, and nearly all the slate stones; these are mostly soon affected by the atmosphere when exposed.

And, thirdly, the *calcareous*, or those formed of lime; a very numerous class, containing all the lime-stones from the marble downwards to chalk. These are the principal ingredients in all cements, and the remains of antiquity sufficiently prove their durability.

STONE, Artificial. A composition which stands the weather, and has the appearance of stone. There are three kinds; one made of the same materials, and resembling pottery ware, baked for a long time, until it becomes very hard. The second is laid on a surface, becoming harder by time; such are Parker's cement, stucco, &c. A third kind, adapted for statues, vases, &c., is made of plaster of Paris and powdered marble dust, mixed up with alum water.

STONES, Precious. (See *Gem.*)

STONE BLUE. A compound of indigo and starch.

STONEWARE. A hard kind of pottery.

STOOL, ELECTRICAL. This is a stool, furnished with glass legs, for the purpose of insulating a person or object placed upon the top of the stool, in order that they may be subjected to electrical influence. A person placed upon a stool of this kind, (its legs being perfectly dry,) and connected with the prime conductor of an electrical machine, when the machine is put in action, the person forming in fact a part of the prime conductor, will become charged with the fluid, so that sparks may be taken from any part of him. A stool of this kind is used in administering electricity medically.

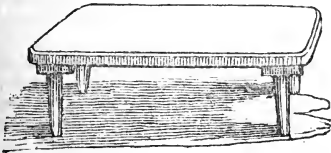

STOP-COCK. The ordinary name given to the small brass taps or cocks used in pneumatic apparatus, and of which the following are representations:—The first figure shows the common stop-cock, which has a male screw at each end. The figure on the side of it is a connecting piece, used to join one stop-cock to another, when it is necessary

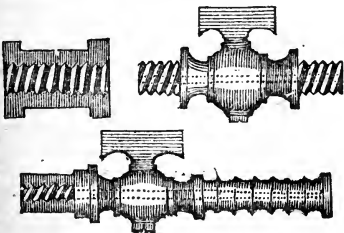

to transfer gases through or into them. The lower figure shows a stop-cock so contrived at one end, that a bladder may be firmly united to it; the other end having a small screw, to which a tube or other apparatus may be attached.

STORAX. STYRAX. A resin which flows from the twigs and trunk of the *liquid amber styraciflua*, a tree which grows in Louisiana, Virginia, and Mexico. Liquid amber, as the resin is so called, is a brown or ash-grey substance, of the consistence of turpentine, which dries up quickly, has an agreeable smell like benzoin, and a bitterish, sharp, and burning taste. It dissolves in 4 parts of alcohol, and affords 1·4 per cent. of benzoic acid.

STORY POST. An upright piece of timber disposed in a story of a building, for supporting the superincumbent part of the exterior wall, by means of a beam over them resting upon two or more story posts.

STOVE. A fire-place, more or less close, for warming apartments. When it allows the coals to be seen, it is called a stove-grate.

STRAIGHT LINE. (See *Line.*)

STRAINING PIECE. In building, a piece of timber used as a strut between other timbers which press equally upon both its ends. This is a general term, and does not imply any particular piece of timber or portion of a building.

STRAKER'S LITHOGRAPHIC PRESS. This is an elegant and powerful instrument for the taking off lithographic impressions. A is a heavy strong table, supporting the rest of the press, which is iron. B is the table, upon which the stone is laid; it draws in and out, when without pressure, by a handle attached

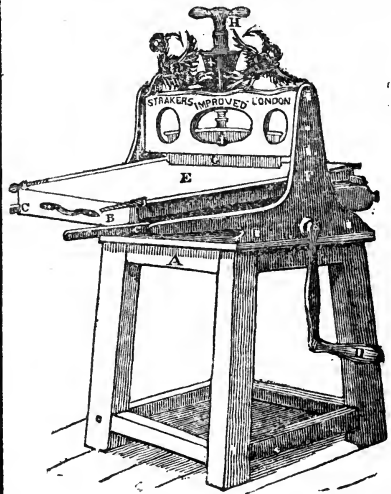

EEE

to one end. C is the scraper, a piece of box wood with a sharp and smooth edge. E is the tympan, supposed in the cut to be turned upon the stone which lies on the table. The scraper is borne down upon E by the screw H, or rather by a short lever which is placed in that situation. F F are the two sides or frame work. D is the handle. To work the press, the stone is placed upon B, a sheet of paper is then put over it; E is then turned down upon the paper. The scraper G adjusted by the lever above; turning the handle draws the table and tympan under the scraper, which thus produces the impression, as explained in *Lithography*.

STRAND. One of the twists or divisions of which a rope is composed; also the name applied to any sea beach or shore that slopes gradually down to the water's edge.

STRANDED. As applied to a rope, signifies that one, at least, of its strands is broken; but when applied to a ship or vessel, it means that she has run on a rock or shoal, and been either rendered unmanageable or entirely dashed to pieces.

STRATA. STRATUM. A single layer or bed of any thing, as a stratum of stone, of gravel, &c.; as applied to a natural deposit of coals or salt, the term *seam* is more commonly used.

STRATUS. A widely-extended and continued sheet of cloud is so called.

STREAM. A flow of water, gas, &c. from one place to another.

STREAM WHEELS. (See *Water Wheels*.)

STRENGTH. In physiology, the same as force.

STRENGTH OF MATERIALS. The force which any material is capable of resisting before it breaks, whether from pulling, compressing, squeezing, from being twisted, or from bending by a force applied laterally.

STRETCHING COURSE. In brick-work and masonry, a row of bricks or stones, with their longest sides exposed to view. The bricks or stones thus laid are called stretchers, and those disposed with the ends outwards are called headers.

STRÆ. The fillets or rays that separate the furrows of fluted columns.

STRIGES. An old word for the flutes of a column.

STRIKING DISTANCE OF ELECTRICITY. The distance at which the electric fluid will pass away in a decided shock or spark from a charged surface to any conductor held near it, particularly as applied to the charged Leyden jar, where it signifies the interval at which the shock passes, when any conductor connected with the outer coating approaches the inner or charged coating. (See *Lane's Medical Electrometer*.)

STRINGING. A name given to a particular kind of inlaying, and also to the material

which is inlaid. It is used chiefly around tables, bird cages, Tunbridge-ware boxes, dressing cases, &c., and consists of very small square, triangular, or other shaped pieces of wood, united by their various edges with glue, so that when done the whole resembles a very long, thin, and regular lath or string of wood, of various colors, according to the woods used. This is let into a channel cut on the surface to be ornamented, glued down and polished. The following shows one among endless patterns of stringing.



STRING BOARD. In wooden stairs, a board placed next to the well-hole, and terminating the ends of the steps.

STRING COURSE. A line of mouldings running along the face of a building, usually under the windows.

STROKE OF PISTON. The elevation or distance which the rod of a pump or of a steam engine piston rises each time, reckoning from its lowest to its highest point of motion. In pumps this may be of any convenient length; in the steam engine it is generally about twice the diameter of the steam cylinder. Thus we speak of a cylinder of 2 feet diameter and 4 feet stroke. The word stroke may also apply to the height to which hammers or stampers are raised, or in other machinery where a blow is produced.

STRONTIA. One of the alkaline earths, of which *strontium* is the base, occurring in a crystalline form, as a carbonate in the lead mines of Strontian, in Argyleshire, whence its name. The pure earth is a greyish white powder, infusible in the furnace, of an acrid burning taste, like that of lime, but even sharper. It becomes hot when moistened, and slakes into a powder; dissolves in 150° parts of water at 60°, and in much less at the boiling point, forming an alkaline solution called *strontia* water. It is not poisonous. The only preparation of strontia used in the arts is the nitrate, which mixed with charcoal or gunpowder, burns with an intensely crimson color; hence it is used in artificial fire-works and theatrical conflagrations.

STRONTIA WATER. (See *Strontia*.)

STRONTITES. The same as strontia.

STRONTIUM. The supposed metallic base of strontia.

STRUCK. An expression used to signify not merely the giving a blow to any thing, but also when any thing of a temporary kind is taken away which has been used for the support of some part of a building during its erecting, as the centre of a vault, &c. is said to be struck.

STRUTS. Any support or straining piece placed upright or nearly so.

STRYCHNIA. An alkaloid principle inherent in the *strychnos nux vomica* and other plants; it is used in medicine.

STUCCO. A kind of mortar, which becomes of a great hardness even under water. It consists of 2 parts fresh-burnt plaster of Paris and 1 of marble dust, mixed with water to the consistence of cream, and poured into moulds, or laid upon the surface of buildings.

STUDIES. In painting, a term applied to those separate parts of a picture first designed and painted unconnectedly, with a view to their future introduction and composition in the entire work. Thus whole figures, in some instances; in others, human hands or feet, animals, trees, plants, flowers; and in short, any thing designed after nature, receive the general denomination of studies.

STUD WORK. The same as brick nogging. (See *Nogging*.)

STUFF. This term is applied to an infinite variety of things; wood is by the carpenter called stuff; so is lime and hair by the bricklayer; plaster by the plasterer, &c. In commerce, stuff is the general name for all kinds of fabrics of gold, silver, silk, hair, wool, cotton, or linen, manufactured by the loom, of which number are velvets, brocades, mo-hair, serges, cloth, &c. The term is also particularly applied to a slight woollen fabric, used principally for linings and female apparel.

STUFFING BOX. A small box at the top of the cylinder of a steam engine, stuffed with a wadding of hemp and tallow, intended to keep the orifice around the piston rod steam-tight. It is formed as follows:—A is the piston rod. C C the top of the steam cylinder, which is made prominent towards the middle. D is a plate pierced so as to admit the piston rod, and furnished with screws to fasten it down to the prominent part of C C, which is the stuffing box. B B is a groove, cut in the box round the piston rod. This is the part to be stuffed full of hemp, anointed with tallow, and this being compressed by the plate D, is packed close to the rod on all sides.

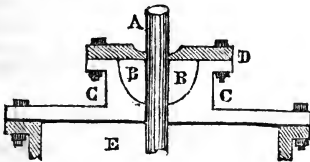

STUM. In the wine trade, the name for the unfermented juice of the grape, when it has been several times racked off and separated from the sediment. The casks to hold this liquor are well fumigated with brimstone, in order to prevent fermentation, through which the juice would become wine.

STURGEON'S CAST-IRON GALVANIC BATTERY. This is a galvanic battery of ten cast iron cylindrical vessels, and the same number of cylinders of amalgamated rolled zinc, used with diluted sulphuric acid. The cast iron vessels are 8 inches high and $3\frac{1}{2}$ inches diameter. The zinc cylinders are the same height as the iron ones, about 2 inches diameter, and open throughout. The iron and zinc cylinders are attached in pairs to each other, by means of a stout copper wire. The zinc of one pair is placed in the iron of the next, and so on throughout the series, contact being prevented by discs of mill-board placed in the bottom parts of the iron vessels. Mr. Sturgeon speaks of this battery as one of extreme power.

STURGEON'S ELECTRO-MAGNETIC BATTERY, consists of a double cylinder of copper, with a ring-shaped bottom connecting the two cylinders, but leaving the outer cylinder without a bottom; the outer cylinder having one or two mercury cups soldered to it. This is shown at B. A cylinder of sheet zinc, without a bottom, is made of a size intermediate between the two copper cylinders. This also has a mercury cup attached, as is seen at C. When the zinc cylinder is placed within those of copper, it has the appearance of A. The zinc is prevented touching the copper either by a string tied round it, or three pieces of cork fastened to the outside of the lower end of the zinc cylinder. It is charged with sulphuric acid and water.

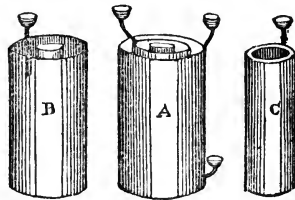

STURGEON'S ELECTRO-MAGNETIC COIL MACHINE. This instrument is for the same purpose, and almost of the same structure, as that already described under *Bachhoffner*; the chief difference being in the method of breaking and renewing contact. The general principle and construction will therefore be easily understood; Z and C being the two wires connected with the battery, and consequently with the primary coil. L H are the ends of the secondary coil. A the foot-board. F an upright pillar with an open glass phial at top, partly filled with mercury. B a cam or break, connected with a small pulley behind, over which a string passes to the larger wheel C. D is a wire, connected with the upright adjoining, and with a socket or a hinge at one end, holding the second

wire E. G are the coils. The parts D E and F being made part of the circuit for the fluid passing along the primary coil, and one end of the wire dipping into the mercury at F, the circuit is complete when the cam B lies flat, but when turned partly round, as in the figure, it lifts up this wire so that its point is removed out of the mercury, and consequently the contact is broken, and an interruption in the continuity takes place. This action and cessation of action is repeated with great rapidity at the revolution of B.

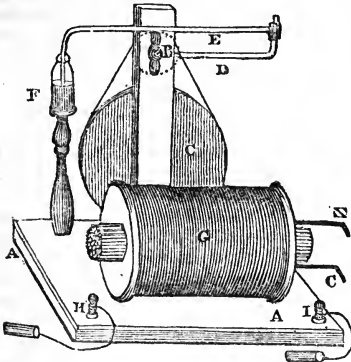

STURGEON'S ELECTRO-MAGNETIC ENGINE. Contrived for the purpose of moving various pieces of machinery, boats, carriages, &c. A is the base board. BB two wooden uprights, supporting the cross bar C C, which passes diagonally from corner to corner across the board. In this cross bar are inserted two smaller pillars, which also carry a cross piece. In the centre of the engine is a vertical shaft, which works freely in two metallic collars; one of which is in the centre of the base board, the other in the centre of the cross piece C C. Above the base board are two circular channels, marked O; one placed above the other. Through the centre of these channels the shaft passes, and is fixed to them. Lower down the shaft passes through the centre of another cross piece; also supported on two pillars. On this cross piece, and concentric with the shaft, are four quadrantal arcs of metal, separated from each other by four narrow openings. Near the top of the shaft is a straight, transverse, compound magnet, N, about 18 inches long. Near the bottom of the shaft is a second similar magnet, marked N S; its poles being reversed to those of the former. In a circle on the base board are the four bars of soft iron I I I I, each wound with six coils of covered bell wire; the similar ends of the coils are united to a stout wire. Thus, although there are six coils, yet two wires only proceed from each, or eight wires in all; four of these are soldered to the quadrantal plates,

each to each. The other four stout wires, which proceed from the top of the coils, terminate by a proper connection with the channels on the spindle, which are filled with mercury. The channels are connected with mercury cups, in which the wires from a battery are placed; one battery at each end of the lowest cross piece. The connections being properly made, the iron bars or cylinders I I I I, become magnetic in succession; and by the joint attractive and repulsive forces of the permanent magnets N and N S, and the temporary magnets I I I I, the former with the shaft and appendages are pulled and driven round. The fly F is intended merely to steady the motion, and the endless screw and wheel W shows one, among numerous other, methods of applying the power.

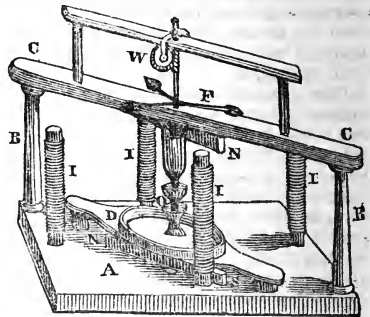

STURGEON'S ELECTRO-MAGNETIC GLOBE. This apparatus was intended to show the effect of an electric current, passing round the equatorial regions of the earth, occasioning the effects of magnetism. Suppose a globe of pasteboard to contain a strong magnet, coincident in position with the magnetic poles or axis of the earth; a delicate dipping needle suspended over this in various parts would be affected in the same way as ordinary needles are by terrestrial magnetism.

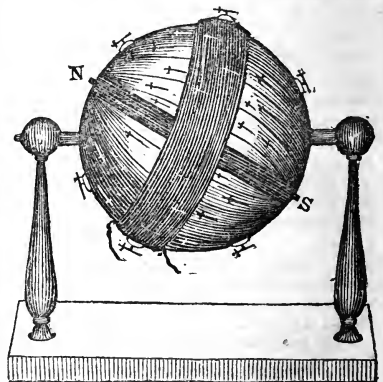

Now take away the central magnet, insert a bar of iron, and wind covered copper wire in a coil around the equator, having the two ends connected with the poles of a galvanic battery, so that a current of electricity runs along the wire. It will now be found that the same magnetic effect will be produced as in the former instance. (See *Barlow*.)

STURGEON'S GUNPOWDER APPARATUS. (See *Gunpowder*.)

STURGEON'S MAGNETOMETER. The same as the oscillatory plate claimed by M. Arago. (See *Arago*.)

STURGEON'S PARALLELOGRAM, is represented below. It consists of a flat parallelogram of copper wire, bent so that one end dips into a mercury cup on the stand; and after passing along the four sides, a part is tied with silk to the former end, (so however that the silk should be between them, that they may not touch;) the wire is then brought straight downwards, and terminates in the mercury cup near N, the former mercury cup A being connected with the cup lower down the stand, near P. When the wires N and P are connected with a charged electro-magnetic or galvanic battery, the fluid will pass along the wire, and giving the one side a north, and the other a south polarity, the parallelogram will arrange itself east and west.

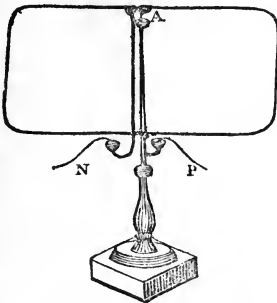

STURGEON'S REVOLVING CROWN. This differs in principle in no respect whatever from the revolving wire, though it does somewhat in the mode of its suspension. The upper pole of the magnet has a cap which fits upon it, and a wire proceeds upwards from the cap, upon which a point underneath the crown of wires rests as on a pivot. The mercury cup A is soldered on to the top of the crown D. The lower end of the crown is a cir-

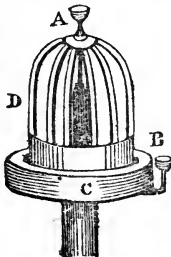

cular rim of very thin brass, which dips into the channel for mercury, made in the disc C. The cup B is connected with this channel of mercury, or it may be formed and connected as in the last apparatus; the present is, however, the usual form, when a steel magnet is used. When there are two crowns on separate magnets, or upon the different poles of the same magnet, it forms a most beautiful experiment.

STURGEON'S REVOLVING MAGNET. There are two distinct instruments known by this name, though one of them is sometimes called Watkins's revolving magnet. They are as follows:—Fig. 1 shows a straight bar magnet A, poised between two pivots, one at each end. The upper point is adjusted by a screw; the lower rests on a piece of brass in the centre of the foot-board. Around this brass piece is a circular cup holding mercury, and connected by a wire with the mercury cup on the side. Half way up the stand is a platform, and a second circular cup also for mercury, the centre being hollow that the magnet may pass freely through it; this is also connected to a cup at the side. Two brass wires screwed into the magnet, one above each cup, dips into the mercury of them. If now an electrical current be sent from B to C, it will pass along the lower half of the magnet, and at the same time occasion the magnet to revolve on its axis.

The second instrument is to show the revolution of a magnet around a wire which conveys a current of the fluid. A B is the wire. It commences in the mercury cup C, and passes down to the brass cup D, which holds a little mercury, and leads to a wire E, that dips into the mercury channel F. The magnet is bent, as represented, D being fastened to it. It rests merely for support however upon the wire G, and has a ring H clamping G to keep the magnet steady in its revolution. When a current of electricity is made to pass from C to F, it passes near to one pole of the magnet and causes its revolution around A B.

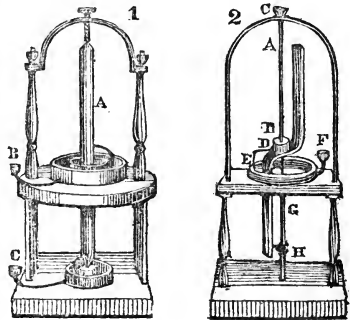

wire F. G are the

REVOLVING SPIRAL TUBE.

is an electrical apparatus of the same nature as the spiral tube. The figures show the front and side-view of the instrument. A A is the foot-board. B B an upright wooden support. C a staple to form with the top of B, a support for the axle, and small pulley P. A cord passes from this to the multiplying wheel W. S is a glass stem, upon the top of which is the wire ring O O. The axis is terminated by a brass ball, on two opposite sides of which are short spiral tubes—these are put in motion by the wheel, cord, and pulley. If, while the spiral revolves, sparks are taken from the machine by the ball shown on the side of O, they will pass down the spiral and produce a most beautiful effect.

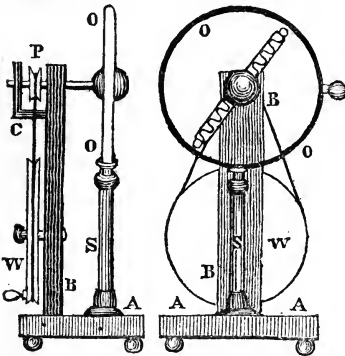

STURGEON'S REVOLVING WHEEL. This electro-magnetic instrument will be best understood by reference to *Barlow's Spur Wheel*, Mr. Sturgeon having discovered that a whole disc is capable of a similar revolution, when placed in like manner between the poles of a magnet, and subjected to the influence of an electrical current passing through it.

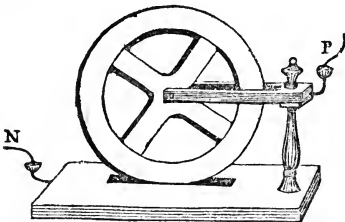

STURGEON'S REVOLVING WIRE. The necessity of employing very powerful magnets in all electro-magnetic experiments, induced Mr. Sturgeon to substitute the temporary electro-magnet for the ordinary steel magnet in numerous experiments, particularly to

produce rotations of wires, &c., as follows:—

A bar, or else a hollow cylinder of iron, (the latter is to be preferred,) is placed upright in a wooden foot; a copper wire, covered with silk or cotton, is coiled round the bar, the lower end being furnished with a mercury cup, the upper end passing into a circular channel, which is cut on the upper side of a round disc, through the centre of which the iron bar passes. The disc supports a wire; on the top of the wire is a mercury cup; under the mercury cup a hook or ring; and to the ring is suspended a wire, of sufficient length to dip into the channel. When a little mercury is put into the channel for the end of the wire to dip into, also a little mercury put into the two cups, and the two poles of a battery be united to the cups, the current will make the iron bar into a temporary magnet; and the current passing at the same time along the wire, it will rotate around the pole of the magnet in one direction or the other, according to the passage of the electrical fluid, whether it be upwards or downwards.

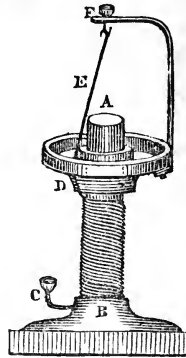

STURGEON'S SEMI-SPIRAL DISC. This is a galvanic apparatus, showing the light given out by various metals when deflagrated by the galvanic fluid. It consists of a brass wheel, set upright on a wooden stand. Upon the face of this wheel are sixteen studs, rising above the surface half an inch or more. These are set in two semi-spiral rows, and are formed of eight different metals in each semi-spiral. The wheel is connected to one pole of a strong galvanic battery by a wire behind it. In the centre is inserted a piece of ivory, and through this an axis of brass, connected with a small handle and mercury cup behind the wheel, and having on the front-end an arm of brass, with eight springs on the under side, so placed as to touch the studs during the revolution of the arm. When the poles of a battery are connected with the mercury cups of the disc and of the arm, and the latter turned round, connection with one pole

and the other will take place, whenever the springs touch the metal studs, and not at other times; a series of sparks will therefore ensue, and the metals being different in nature, the color of the spark from each will vary from the rest.

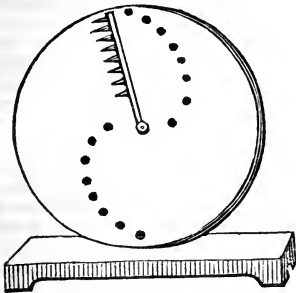

STURGEON'S SPIRAL CARD. If a piece of wire be bent in the form of a flat spiral, as shown in the figure, and this be suspended in mercury cups at the top and bottom, the mercury cups themselves bearing wires from the two poles of an electro-magnetic battery, as is seen at A P, B N, (the whole distance between A and P, and also B N, being metallic,) a current of electricity sent from P to N will of necessity pass through the coil, and changing it into a temporary magnet, it will at the same time obtain polarity, and turn in the direction E and W; one side of the wire having a north polarity, and the other side a south polarity. The instrument is best made with a card, upon which the wire may be shown. The straight part of it from the centre downwards, passing through the middle and at the back of the card.

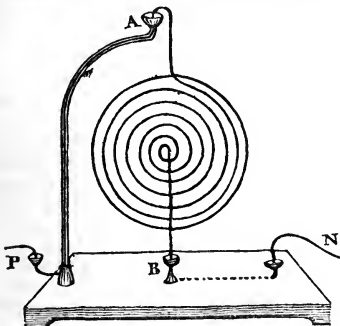

STYLE. In all the arts, the union of all those several parts which unite in the conception, composition, and execution of a work of art. The word is applied to painting, poetry, sculpture, architecture, &c. A style is also any thing with a sharp point, and of a small size, as a graver, an etching needle, &c.

STYLE. In chronology, a particular manner of counting time, as the new style, the old style. The old style is the Julian manner of computing, as instituted by Julius Cæsar, in which the mean year consists of $365\frac{1}{4}$ days. New style is the Gregorian manner of computation, instituted by Pope Gregory XIII. in the year 1582, and is used in most countries of Europe in the present day. In this the year consists of $365\frac{1}{4}$ days, but it differs from the old style inasmuch as this quantity being rather too much to agree with the solar year, three days are omitted in 400 years; thus reducing the year so as very nearly to agree with the earth's revolution round the sun.

STYLE. In architecture, is any particular fashion or general method of building, not confined in the relative proportion of parts to any set of rules or scientific regulations, distinguished therefore from order. Thus each country, even the most savage, has its peculiar style of building. The different wants of succeeding ages of civilization also required alterations of style, while improved taste will improve style also. Thus we speak of the different styles of Gothic architecture, distinguishing them as the *Anglo-Saxon*, *Norman*, the *early English*, the *decorated*, the *perpendicular*, and the *Flamboyant*. So also speaking of different countries and times we say, the *Moorish style*, the *Chinese*, *Persian*, *Turkish*, *Hindoo*, *Venetian*, *Elizabethan*, *Anglo-Greek*, &c.

STYLOBATE. A basement of brick-work, or of masonry beneath columns.

SUB-CONTRARY POSITION. In geometry, is when two similar triangles A E D, A E C, are so placed as to have one common angle A at the vertex, and yet their bases not parallel, consequently the angle at the bases are equal, but on contrary sides.

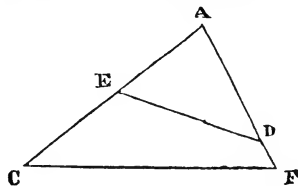

If an oblique cone with a circular base, whose diameter is B C, be so cut by a transverse plane, as to make in the section A B C,

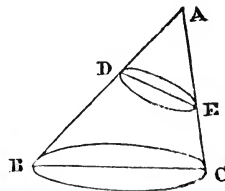

through the vertex A, the angle E=the angle B and D=C; then the cone is said to be cut by the transverse plane in a sub-contrary position to the base B C, and in this case the section whose diameter is D E is always similar to B C.

SUBDUCTION. (See *Subtraction.*)

SUBDUPLICATE RATIO OF TWO QUANTITIES, is the ratio of their square roots; as $\sqrt{a} : \sqrt{b}$ is the subduplicate ratio of $a : b$.

SUBERIC ACID. An acid obtained from cork; *suber* being the specific name of the cork tree.

SUBLIMATE. Any solid matter resulting from sublimation.

SUBLIMATION. A process by which volatile particles are raised by heat, and condensed into a crystalline mass. Zinc when melted and burned in a hot fire becomes sublimed, or flies off in a copious white powder, which is an example of sublimation.

SUBLIME GEOMETRY. The geometry of curve lines.

SUBMULTIPLE. The same as aliquot or equal part; thus 3 is the submultiple of 21. That is, when 3 is multiplied by another number it will make 21. 2, 3, 4, and 6, are all submultiples of 12.

SUBNORMAL, or SUBPERPENDICULAR. The distance upon the axis between the foot of the ordinate, and a perpendicular to the curve or its tangent. In all curves the subnormal is the third proportional to the subtangent and the ordinate, and in the parabola it is a constant quantity.

SUBSALT. A salt having an excess of base beyond what is requisite for saturating the acid, as supersalt is one with an excess of the acid. Thus sulphate of potass is the neutral compound of sulphuric acid and potass; subsulphate of potass, a compound of the same ingredients, in which there is an excess of base; supersulphate of potass, a compound of the same acid and the same base, in which there is an excess of acid.

SUBSTANTIVE COLORS. In dyeing, are such colors as unite immediately with the stuff, without the necessity of using a mordant.

SUBSTITUTION. In algebra, is the putting or using one quantity for another to which it is equal.

SUBTRACTION. (See *Subtraction.*)

SUBSTYLE. In dialling, the right line on which the style or gnomon is fixed.

SUBTENSE OF AN ARC OR ANGLE, is the line by which it is subtended or cut off.

SUBTRACTION. One of the fundamental rules of arithmetic, and by which numbers or quantities are taken from each other, and their difference ascertained. It is divided into simple subtraction, or that which relates to whole numbers of one denomination only; and compound subtraction, where the differ-

ences of compound amounts of monies, weights, or measures, are ascertained.

SUBTANGENT. The line that determines the intersection of a tangent with the axis, or that determines the point wherein the tangent cuts the axis prolonged, as T B in the annexed figure.

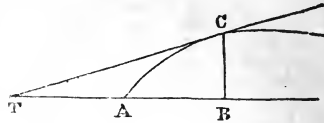

SUBTRAHEND. In subtraction, is the smaller number, or that which is to be taken from the other, which other is called the *minuend*, that is, the number to be diminished.

SUBTRIPLE. One number or quantity which is the third part of another; and *subtriple ratio* is the ratio of 1 to 3.

SUBTRIPPLICATE RATIO, is the ratio of the cube root; thus $\sqrt[3]{a}$ to $\sqrt[3]{b}$ is the subtriplicate ratio of a to b .

SUCCESSION OF SIGNS. In astronomy, called also *consequentia*, is the same order as that in which the sun enters the signs of the zodiac and passes through them, as Aries, Taurus, Gemini, Cancer, &c. When a planet's motion is according to this order, it is said to be direct; but when it moves in a contrary way, it is said to be retrograde.

SUCCINIC ACID. *Acid of Amber.* *Salt of Amber.* Obtained by distilling coarsely pounded amber in a retort by itself, with a heat gradually raised, or mixed with one-twelfth of its weight of sulphuric acid, diluted with half its weight of water. It is afterwards purified. Its salts are called succinates, one of which, the succinate of ammonia, is an excellent test for iron in solution.

SUCCULA. In mechanics, a bare axis or cylinder, with staves in it to move it round, but without any periphery or drum.

SUCTION. The action of sucking is performed by the child's making a vacuum in its mouth, which exhausts the air from the pores of the nipple, and the milk is consequently ejected from the breast by the unresisted elasticity of the air within. The raising of liquids through a tube, by means of a piston which lifts and sustains the weight of the atmosphere from that part of the well which is covered with the tube, leaving it to press on the other parts of the surface is also metaphorically termed *suction*.

SUCTION PIPE. The lower pipe of a pump, that which proceeds to the well.

SUCTION PUMP. This is the common household pump, called a suction pump from the old belief that it derived its action from a principle of suction. Suppose A to be a

pipe, leading to the well of water. C the pump barrel, part of which is removed to show the valves. E is the pump handle. F a spout, to throw off the water raised. G the bucket or valve belonging to the piston which is at the end of the pump rod. H the lower valve or suction valve. When E is drawn up, it will, at the same time, draw up G, and occasion a vacuum or empty cavity between G and H. The water below H will immediately rush up and fill the cavity. It was formerly said it was sucked up; its ascent is now known to arise from the pressure of the atmosphere upon the water in the well, forcing up the water until it rises in the pipe to a height of 32 feet, a column of water of that height weighing 15 lbs. per square inch of surface, which is equal to the weight of the atmosphere. When E is entirely drawn up, the water will have filled the space between the valves. Upon pressing E down again the water cannot return, because the valve H closes; instead of which the valve G opens, and the whole of the bucket descends through the water. When E is again drawn up, G shuts, and the water above G is lifted up, and flows away; at the same time H opens, and a fresh supply of water fills the lower part of the pump barrel as at first.



SUGAR. A sweet constituent of animal and vegetable products. There are two principal classes of sugars; one derived from the juice of the sugar cane, (*Saccharum officinale*), the beet root, and the maple. This is commonly known as sugar, divided into *treacle*, when liquid; *foots*, when partly crystallized; *Muscovado* or *raw sugar*, when crystallized, but still impure, and more or less colored; *refined* or *loaf sugar*, when purified and hastily congealed into small crystals; *sugar candy*, when set aside to crystallize very gradually. The second class of sugars contains such as are derived from fruits, as from the fig, the grape, dates, &c. This does not crystallize, and has scarcely more than half the sweetening power of the former. It is also produced artificially, by treating starch with sulphuric acid, and boiling them together. Chemists enumerate other kinds of sugar, as the sugar of milk, diabetes sugar, of manna, of certain mushrooms, of liquorice root, &c.

SUGAR OF LEAD. Acetate of lead.

SULPHATES. Saline compounds of sulphuric acid, with oxidized bases. The minutest quantity of them present, in any solution, may be detected by the precipitate, insoluble in nitric or hydrochloric acid, which they afford with the nitrate or chloride of

barytes. The sulphates are mostly insoluble in alcohol.

SULPHATE OF ALUMINA AND POTASS. The same as alum.

SULPHATE OF BARYTA. A mineral, called also heavy spar.

SULPHATE OF COPPER. Blue vitriol; blue stone; Roman vitriol.

SULPHATE OF IRON. Green vitriol, or copperas. This is the basis of all black inks and black dyes. When calcined, it forms jeweller's rouge, crocus of Mars or colcothar of vitriol; used for polishing steel and other goods, and to apply to razor straps.

SULPHATE OF LIME. Gypsum or plaster of Paris. (See *Plaster*.)

SULPHATE OF MAGNESIA. Epsom salts or hair salt of old writers.

SULPHATE OF MANGANESE is much used by the calico printer.

SULPHATE OF SODA. Glauber's salts.

SULPHATE OF ZINC. White vitriol. This is used in drying lotions, in preparing drying oils for varnishes, and in the reserve or resist pastes of the calico printer.

SULPHATIC ETHER. Sulphate of hydrocarbon; oil of wine; heavy oil of wine.

SULPHITES. A class of salts, consisting of sulphurous acid, combined with the various bases.

SULPHOADIPIC ACID. When olive oil is carefully mixed with sulphuric acid, so as to avoid the heating of the mixture, a thick brown compound is formed, from which water separates all the oil in an altered state, and retains in solution a peculiar compound of hyposulphuric acid and organic matter, which Chevreul has termed sulphoadipic acid.

SULPHOCYANIC ACID. HYDROSULPHOCYANIC ACID. **SULPHURETTED CHYAZIC ACID.** **SULPHURO-PRUSSIC ACID.** A triple compound of sulphur, cyanogen, and hydrogen. It is thus procured:—Mix equal weights of flowers of sulphur and powdered ferrocyanuret of potassium, and keep the mixture melted in a flask for half an hour; when cold reduce the mass to powder, and digest it in water. Filter the solution, and add a sufficiency of liquid potassa to throw down the iron held in solution. The liquid thus obtained is a solution of the sulphocyanuret of potassium, from which liquid sulphocyanic acid may be obtained by distillation with phosphoric or sulphuric acid. It is of a pinkish hue, with an acetic odour, and is characterized by the peculiar blood-red color, which it produces when mixed with persulphate of permuriate of iron.

SULPHOCYANIC ETHER. By distilling a mixture of 1 part of sulphocyanuret of potassium, 2 of sulphuric acid, and 3 of anhydrous alcohol, Leibig obtained a compound consisting apparently of sulphuret of cyanogen and etherine.

SULPHOCYANURET OF POTASSIUM. (See *Sulphocyanic Acid.*)

SULPHOCYANURETS. Compounds of sulphuretted hydrogen and cyanogen.

SULPHOMETHYLIC ACID. An acid substance, obtained by the decomposition of the sulphate of methylene by boiling water; this liquid resolving it immediately into regenerated methylene and sulphomethylic acid.

SULPHONAPHTHALIC ACID. **SULPHONAPHTHALIN.** A combination of naphthaline and sulphuric acid.

SULPHOVINIC ACID. The name given by Vogel to an acid or class of acids, which may be obtained by digesting alcohol and sulphuric acid together with heat. It is probable that this acid is merely the hyposulphuric, combined with a peculiar oily matter.

SULPHOSELS, or SULPHOSALTS, is a name given to a double sulphuret, prepared as follows:—Dissolve a salt, consisting of an oxide and an acid, (an oxisalt), in a very small quantity of water, and pass through the solution a stream of sulphuretted hydrogen, till the salt be entirely decomposed. In this operation the oxisel is transformed into a *sulphosel*, by the action of the compound gas, while its hydrogen forms water with the oxygen of the saline base. This process is applicable only to the metallic salts, and among these not to the nitrates, carbonates, or phosphates.

SULPHOSINAPIC ACID. An acid found in the seeds of mustard, radish, and turnip, and some other cruciferous plants; in the roots of horse-radish, &c.

SULPHUR. Brimstone; a simple combustible, solid, non-metallic, brittle, hard, crystallized, yellow substance; the produce chiefly of volcanic countries. It burns with a blue flame and pungent suffocating odour; melts at a heat of 226° ; becomes thick and dark colored by an increase of heat, and takes fire at 569° . When a lump of it is rubbed, it becomes negatively electrical. It unites readily with oxygen, metals, &c.; forming sulphurets in the latter case and acids in the former. Sulphur unites with oxygen in four proportions, forming acid products; the constituents of which are as follows:—

Sulp. 1, ox. 1 atom, forms hyposulphurous acid.
Sulphur 1, oxygen 2 atoms, forms sulphurous acid.
Sul. 1, ox. $2\frac{1}{2}$ atoms, forms hyposulphuric acid.
Sulphur 1, ox. 3 atoms, forms sulphuric acid.

Sulphur is found in commerce of various forms. *Massive* or native sulphur, as found in the volcanic countries. *Roll* sulphur, made usually from the sulphurets of copper or iron, and cast in the shape of rolls or cylinders. *Sublimed sulphur* or *flowers of sulphur*, in the state of a fine powder, and as precipitated from the alkaline sulphuret by an acid, called then *milk of sulphur*, or *precipitated sulphur*.

SULPHUR CONE. An electrical experiment and apparatus to prove the effect of separation of the contact of two bodies, occasioning them to show signs of electricity. Take a large wine glass, paste a small piece of tin-foil over the lower part of the glass, twist a wire round it, and suffer the end to project, in order to support a pair of pith balls. Pour melted sulphur into the glass, and insert a glass rod into the sulphur while yet liquid. In the present state no electrical effect will be perceived, but when the sulphur cone is lifted out by the glass rod, the pith balls will immediately diverge, collapsing again when the sulphur is replaced, and thus the divergence and collapse may be renewed at pleasure for a long period of time.



SULPHUR VIVUM. The impure sulphur remaining in the alembic after sulphur has been sublimed from the crude state.

SULPHURATION. The act of bleaching any thing by subjecting it to the fumes of burning sulphur shut up with it in a box or close room. This is done as a means of bleaching the article.

SULPHUREOUS. Any thing containing or appearing by the senses to contain sulphur.

SULPHURET. A combination of sulphur with a metal or other simple body, or with an earth or alkali.

SULPHURETTED ALCOHOL. A solution of sulphur in alcohol; obtained by boiling them together, or preferably by suffering the fumes of boiling alcohol to unite with the fumes of burning sulphur in a close vessel.

SULPHURETTED CHYAZIC ACID. (See *Sulpho-Cyanic Acid.*)

SULPHURETTED HYDROGEN. A gaseous compound of hydrogen and sulphur; formed by pouring a little sulphuric or muriatic acid upon the black sulphuret of iron or antimony in a retort. It takes fire when a lighted taper is brought in contact with it, and burns with a pale blue flame, depositing sulphur. Its smell is extremely fetid, resembling that of rotten eggs. It reddens vegetable blues. It is absorbable by water and of all the gases—sulphuretted hydrogen is perhaps the most deleterious gas to animal life. A goldfinch plunged into air which contained only a fifteen hundredth part of its volume, perished instantaneously. A dog of middle size is destroyed in air containing $\frac{1}{800}$; and a horse would fall a victim in an atmosphere containing $\frac{1}{250}$ part. Sulphuretted hydrogen combines with an equal volume of ammonia, and unites to alkalis and oxydes, so that it has all the characters

of an acid. These compounds are called *hydro-sulphurets*.

SULPHURETTED SPIRIT. A compound of sulphuretted hydrogen and ammonia.

SULPHURETTED SULPHITES. The same as the hypo-sulphurous acid.

SULPHURIC ACID. OIL OF VITRIOL. A compound of sulphur and oxygen, in the proportion of 1 atom of the former to 3 of oxygen. It is almost universally procured in this country by the combustion of a mixture of about 8 parts of sulphur and 1 of nitre. The fumes arising pass into a leaden chamber, the floor of which is covered with water; this absorbs the acid fumes, and when it has thus acquired a certain specific gravity it is drawn off, and concentrated by boiling, the water being lighter than the acid flies off in vapour. Sulphuric acid is intensely acid and caustic, has a soapy feel, is extremely sour, and has so strong an attraction for water that their quick union produces very considerable heat. It possesses intense chemical powers, it displaces the greater number of acids from their combinations, and chars most animal and vegetable substances.

SULPHURIC ACID, German. When the sulphate of iron is calcined, till it falls down in a white powder, then put into an earthen or glass retort, and gradually exposed to a red heat, a dark colored acid liquor distill over, of a specific gravity of about 1.89, which has been called *Nordhausen* or German sulphuric acid. This brown fuming acid is in request as a ready and perfect solvent of indigo. It smokes when exposed to the air.

SULPHURIC ACID, Glacial or Anhydrous. When sulphuric acid was procured by the distillation of green vitriol, it was frequently observed, that a portion concentered into a white mass of radiated crystals. This has been called *glacial* or *fuming* sulphuric acid, and is considered as the pure or anhydrous acid.

SULPHUROUS ACID. An acid whose constituents are 1 atom of sulphur and 2 of oxygen. It was first examined by Stahl, who called it *phlogisticated sulphuric acid*. It may be procured by burning sulphur in oxygen gas. It is a gaseous body, rapidly absorbed by water. Its specific gravity, as compared to hydrogen, is as 32 to 1, or more than twice the weight of atmospheric air. It is easily condensable by cold and pressure into a liquid. It has a suffocating odour, extinguishes the light of a taper, and the life of an animal.

SULPHURIC ETHER. An ether procured either by distilling a mixture of sulphuric acid in alcohol, or by suffering alcohol gradually to dribble into the heated, and somewhat diluted acid.

SUM. The aggregate of any two or more quantities; formed by adding them together.

SUMACH. The name of a shrub, (*Rhus coriaria*,) which grows naturally in Spain and other places; the wood of which dried and pounded is used for the purposes of dyeing and tanning. In the former art it produces, when used alone, a fawn color, when with the acetate of alumina as a mordant, a good yellow.

SUMMER. One of the seasons or quarters of the year, beginning about the 21st of June and ending on the 22nd of September. Summer is also often used to denote one half of the year: viz. the time in which the sun passes through the northern signs, namely from about the 21st of March to the 22nd of September, exceeding the winter, or the time in which he passes through the southern signs by about seven days.

SUN, The. In astronomy, the great source of light and heat to the solar system, about which as a centre the several planets perform their revolutions, and to the influence of which, combined with their sidereal and diurnal revolution, they owe the successive alternations of summer and winter, day and night. The sun is the largest of all the heavenly bodies; his diameter is 111.454 times that of the mean diameter of the earth, whence his volumn is 1384472 times greater than that of the earth, but its density being only one quarter as great, we may consider his mass to be 337086 times that of the earth. He is surrounded by an atmosphere of great extent, and is frequently obscured by spots, some of which have been observed so large as to exceed the earth five or six times in diameter. The observation of these spots shows that the sun turns on his axis in 25½ days. The sun, together with the planets, moves round the common centre of gravity of the system, which centre is nearly in the centre of the sun, and this motion changes the orbits of the planets into epicycloids. The sun also appears to have a particular motion, which carries our system towards the constellation Hercules.

SUN AND PLANET WHEEL. A contrivance

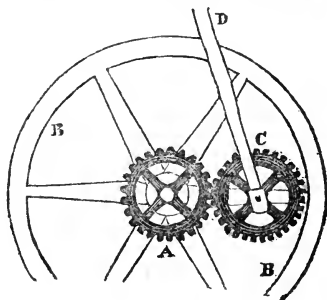

of the celebrated James Watt, for superseding the crank in the steam engine. Suppose A to be a cogged wheel, attached to the shaft of the fly wheel B B; and that another wheel C, with cogs similar to those upon A, be suspended from the end of the beam D, which is connected with the working beam of the steam engine. As D ascends and descends, it will necessarily work the wheel A, putting that and all connected with it in motion; at the same time it will travel round A, in the same manner as a planet travels round the sun; A rod B, (not shown in the cut,) connects the axes of the wheels A and C.

SUNDAY LETTER. (See *Dominical Letter*.)

SUN DIAL. (See *Dial*.)

SUPERFICIAL. Shallow; relating to surface only.

SUPERFICIAL CONTENT OF ANY THING. The number of square inches, feet, &c., contained on its surface.

SUPERFICIAL MEASURE. The same as square or land measure.

SUPERFICIES. The outside or exterior surface of any body. This is considered as of two dimensions; viz. length and breadth, but without thickness, and therefore forms no part of the substance, or solid content of the body. The boundaries or extremities of a superficies are lines, and it is said to be a *rectilinear* or *curvilinear* superficies, according as the bounding lines are curved or straight. Superficies are further divided in *plane* or *flat*, *concave* and *convex*.

SUPERPARTICULAR RATIO. An obsolete term for a ratio when the two terms differ only by units.

SUPERPARTIENT RATIO. Also obsolete, is a ratio where the terms differ by more than unity, but the greater is less than double the other.

SUPERSALT. (See *Subsalt*.)

SUPERSTRUCTURE. Any thing built upon a foundation previously made to receive it.

SUPPLE. A quality opposed to hardness or inflexibility.

SUPPLEMENT OF AN ARC. In trigonometry, is what it wants of 180° .

SUPPORTERS OF COMBUSTION. The only true and perfect supporter of combustion is oxygen, though the gases chlorine and nitrous oxide, also iodine and bromine, will in some cases act as such.

SURBASE. A cornice or series of mouldings on the top of the base of a pedestal, podium, &c.

SURD. In arithmetic and algebra, denotes the root of any quantity, when that quantity is not a complete power of the dimension required: thus $\sqrt{2}$, $\sqrt[3]{4}$, $\sqrt[4]{7}$, are surds or irrational quantities. Surds are either *simple* or *compound*. A simple surd is that which consists of only one term, as $\sqrt{2}$, $\sqrt[3]{6}$, &c. A compound surd is that which

consists of two or more terms or radicals; thus $\sqrt{3} + \sqrt{2}$ are compound. These last, when consisting of only two terms, are also called *binomial*.

SURFACE. The same as superficies; the former word being generally used on ordinary occasions; the other when treating of mathematical subjects.

SURFACE CHUCK. A chuck used for the purpose of holding any flat material, while the surface of it is turned flat and even; for example, the backs of stereotype plates. The chuck is formed of course with a screw which fits the mandril of the lathe; the front of it presents a true and even surface, sometimes of a foot or more in diameter; four holes pass through the face. The work is held by dogs, screws or flanches; three sorts of which are represented below. The screw of these passes through the holes in the face of the chuck, and the work being placed between them, and properly adjusted to the centre, the dogs are screwed up from behind, or in the front, as may be found most convenient. Flat and very irregularly-shaped bodies may thus be attached to the lathe more readily than by any other means.

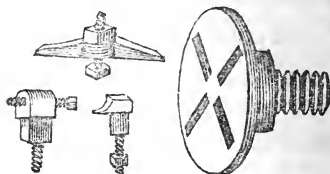

SURSOLID. A term given by the early algebraists to what we now call a fifth power.

SURVEY. A measured plan and description of any line or area of country.

SURVEYING. In a general sense denotes the art of measuring the angular and linear distance of objects, finding their superficial content, ascertaining their nature, solidity, and adaptation to specific purposes, &c.; thus, measuring the distance and position of a lighthouse; depth of water in a bay; the measurement of land; of artificer's work; the repairs or solidity of a building; position and level of roads and canals; condition of a camp, or of a mine, of machinery; excavations of the earth; and numberless other matters, are the subjects of surveying. Many kinds of surveying, therefore, are in use, each distinct from the other; thus we have *marine* surveying, *land* surveying, *house* surveying, *military* surveying, &c. In the more limited acceptance of the word, *land surveying* only is intended. This is conducted in several manners, according to the nature of the ground; for example, supposing it should be an irregular field of the shape beneath, it would be measured by taking the base line along the field, and by means of the

theodolite, the cross, or some other instrument, taking lines perpendicular to this, reaching to the various angles. If the length of these lines be taken, and also the various distances along the base line where they start from, it will divide the field into a number of right-angled parallelograms or right-angled triangles, A, B, C, D, E, F, G, H, I. The content of each is calculated, and then the sum of all of them is the content of the field.

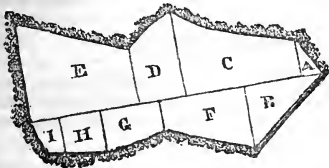

It will be obvious upon looking at the following cut that a different measurement would be more convenient. Here the field is divided into triangles, the perpendicular height of each of which is taken at the same time, BB, C C, D D, &c., forming one triangle. The content of each is ascertained, and the area found as before.

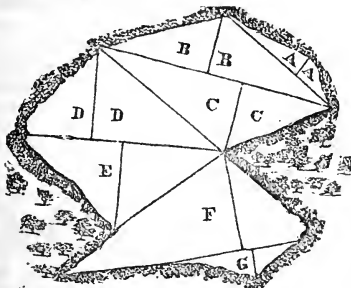

It often happens that the intervention of water, wood, corn-fields, &c. prevents the actual passage of the surveyor over the ground; in that case he must contrive to take some one base line across a field or along a hedge, and from the ends of that line take the angular position of distant points, calculating afterwards the remaining sides of the triangles thus got out by trigonometry. Marine surveying, such as that of harbours, bays, &c., is performed by this method. The implements used in surveying are *Gunter's Chain*, the *Cross*, and the *Theodolite*, (see these words; also *Arrow*, *Base Line*, *Offset*, &c.)

SURVEYING WHEEL. (See *Perambulator*.)

SUSPENSION. In mechanics, the balancing or supporting any body from a point above it, which point is called the *point or centre of suspension*.

SUSPENSION BRIDGE. A bridge suspended from inverted bows, by means of rods, being usually formed of iron. The bows are supported by stone piers erected at or near the

ends, and from thence carried down and secured in the ground. From the bows being of numerous links, united together, this is often called a *chain bridge*.



SWAG. An unequal or hobbling motion.

SWALLOW TAIL. The same as dove tail, (which see.)

SWAN, Electrical. An experiment to show electrical attraction. Procure a swan, made of wax, wood, or very thin metal; when of wax or wood, cover a part of its body with tin-foil, float this in a large basin of water and put the water on an electrical stool. Turn the machine, and upon holding the finger or a piece of bread towards the swan, it will be attracted to the hand.

SWAN, Magnetic. A figure like the last; but containing a large sewing needle, placed from the head to the tail. Floating in a basin of water on a table, this figure will be attracted by a magnet held towards it.

SWANPAN, or SCHWAMPAN. The abacus or counting table of the Chinese, by which they perform their usual mercantile calculations. It is a square frame of wood or bamboo, with a division across it, and ten transverse wires, upon each of which, both below and above the division, are five beads; each wire representing a number, (as the digits do among us,) and each bead giving a particular value to the number, like units, tens, hundreds, and so on. (See *Abacus*.)

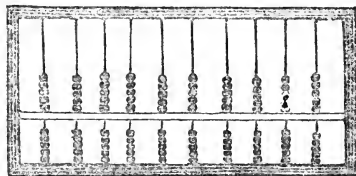

SWEETS. A technical word for molasses or treacle.

SWEET SPIRITS OF NITRE, or DULCIFIED SPIRITS OF NITRE. Nitrous ether. This is used to communicate a flavor to British brandy.

SWEET SPIRIT OF SALT, or DULCIFIED SPIRIT OF SALT. Hydrochloric ether.

SWEET WINES. Those wines are called sweet which are made by the addition of sugar to the juice of the fruit, and the fermentation of which is not carried so high as to convert all this sugar into alcohol, but leaving it in the wine, occasions a sweet flavor.

SWEINFORD GREEN. (See *Scheele's Green*.)

SWELLED COLUMN. One the shaft of which is largest in the middle of its length.

SWING, Electrical. An experiment of electrical attraction, in which a figure, suspended from a silk thread, and supported upon two glass pillars, is made to vibrate between a ball which is charged with electricity, and one which is connected with the earth. Suppose A to be connected with the prime conductor of an electrical machine. B a stand of baked wood. C a ball, connected with the earth. The figure, when the machine is put in action, would vibrate between the two balls.

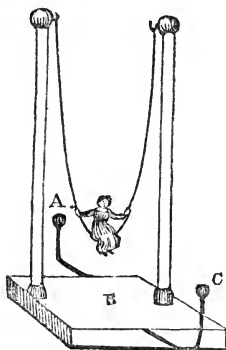

SWING TREE. Any beam that vibrates.

SWITCH. That part of the rails of a railway where a side cutting joins the main rail, and which being moveable sideways enables a carriage to continue straight forwards, or to move into the side rails, as may be desired. The switches are in some cases fixed; in others moveable sideways by a cross rod and lever attached to them.

SWIVEL. A thing fixed in another body to turn round upon.



SWIVEL, or SWING BRIDGE. A moveable bridge, much employed in docks, in order to admit the passage of shipping, consisting of two parts or platforms, their point of meeting being midway between the abutments; each portion turning upon a centre pivot, and supported upon rollers; the overhanging portion is balanced and kept in position by a counter-balancing weight fixed within the framing of the other end.

SYLVIVS, SALT OF. Muriate of potass.

SYMBOLS. Marks or characters, used as

an abbreviation for objects, substances, or scientific operations. The symbols relative to the subjects in this "Dictionary" are chiefly those belonging to astronomy, chemistry, and the mathematics. The first class are given under *Astronomy*. The chemical symbols are extremely various, each distinguished chemist forming for himself a collection of them. Thus we have the symbols of the alchemists, of Bergman, Berzelius, Dalton, and others. These are for the most part arbitrary, and now but little attended to; it being considered sufficient to indicate the component parts of a body, by the initial letter or letters of its constituents, and the equivalents of them, with the sign of addition between, as may be seen in the following example:—

Carbonic oxyde (*car + o*) or *c + o*

Carbonic acid (*car + 2o*)

Carbonate of ammonia (*a + car*)

Peroxyde of nickel (*nic + 1½o*)

Deutoxyde of antimony (*an + 2o*)

Most of the symbols used in the mathematical sciences are well known. They, with their names, are as follows:—

+ Plus or more, the sign of addition.

− Minus or less, the sign of subtraction.

× Multiply or multiplied by.

÷ Divide or divided by.

= Equal or equal to.

As : is to :: so is : to, ratio or proportion.

1² Square √ Square root.

1³ Cube √ Cube root.

□ Square; and numerous others

SYMMETRICAL EQUATIONS. In algebra, are those equations consisting of two or more unknown quantities similarly involved, so that no difference will arise by writing these quantities reciprocally for each other.

SYMMETRY. Exact accordance with the rules of beauty. It is absolute or relative, uniform or respective. Absolute or uniform symmetry is when every part accords with all the rest in size, form, and material. Relative symmetry implies also uniformity or structure, as a building may be in just proportion, and therefore absolutely symmetrical, but having one wing larger than the other, it is not relatively so, the opposite sides not corresponding with each other.

SYMPATHETIC INK. An ink which makes no mark upon the paper until it is submitted to heat, or until a second liquid is passed over it. Of the first kind, numerous examples might be given, as milk, onion juice, lemon juice, sulphuric acid, &c. This makes no mark until the paper is heated, when the writing appears more or less black, and always remains so. If a solution of the muriate of copper be used, it will appear

yellow when heated. The acetate of cobalt will give a green color, and the chloride of cobalt a fine blue. These colors again disappear as the paper cools. The second class of sympathetic inks may be understood by the following examples:—Write with a solution of sulphate of iron; the writing will not appear till the paper be washed over with some substance which will decompose this; for example, tincture of galls will produce a purple, and prussiate of potass a blue.

SYMPIESOMETER. The invention of Mr. Adie, optician, of Edinburgh, and for which a patent was procured. It

is thus described in the words of the patent:—The principle of the instrument consists in measuring the weight of the air by the compression of a column of gas. It is formed of a tube of glass, A B C D, about 18 inches long and 0·7 of an inch in diameter inside, terminated above by the bulb D, and having the lower extremity bent upwards, and expanding into an oval cistern A, open at the top. The bulb D being filled with hydrogen gas; and a part of the cistern A, and the tube B with almond oil, colored with alkanet root, the inclosed gas, by changing its bulk according to the pressure of the atmosphere on the oil in the cistern, produces a corresponding elevation or depression of the oil in the tube. The scale for measuring these changes is determined by placing the instrument, with an accurate barometer and thermometer, in an apparatus where the air can be rarefied or condensed, so as to make the barometer stand at 27·30, or any other number of inches. The different heights of the oil in the tube corresponding to those points being marked on its scale E F, and the spaces between them being divided into 100 equal parts; these divisions represent hundredths of an inch in the mercurial column. To allow for the effect of variations of temperature upon the inclosed gas, the principal scale E F is made to slide on another G H, so graduated as to represent the amount of such changes, corresponding to the degrees of a thermometer, I K, which is attached to the instrument.

SYNCHRONISM. The being or happening of several events at the same time, as isochro-

nism denotes two or more things being performed at the same time; the first arising from a natural, the other from an artificial cause.

SYNODIC, or SYNODICAL MONTH, is the interval or period of time in which the moon passes from one conjunction with the sun to another, and is therefore precisely one lunation, the mean duration of which is 29 d., 12 h., 44', 28".

SYNODIC REVOLUTION OF A PLANET, is the time between two conjunctions or two oppositions of the same planet and the sun.

SYNTHESIS. Denotes a method of composition as opposed to analysis or resolution. In chemistry, for example, we prove the composition of a substance by mixing together what we know to be its constituent principles, thereby forming that substance. In mathematics, by the synthesis or synthetic method, we pursue the truth by reasoning drawn from principles before established or assumed, and propositions formerly demonstrated; thus proceeding by a regular process till we arrive at a conclusion.

SYNTHETICAL METHOD. (See *Synthesis*.)

SYPHON. (See *Siphon*.)

SYPHON BAROMETER, or REDUCED BAROMETER. This instrument is about 4 inches long. It consists of a tube doubled upon itself twice, and very nearly filled with mercury. It serves the purpose of a manometer, in showing the dilations of the air in the receiver of an air pump, for which purpose it is commonly employed.

SYPHON GAUGE. (See *Gauge*.)

SYRINGE. In hydraulics, a small simple machine serving first to imbibe and suck in a quantity of water or other fluid, and then to expel the same with violence in a small jet. The boy's squirt is an example. (See *Condensing Syringe*.)

SYRUP. A solution of sugar in water.

SYSTEM. In a general sense, denotes an assemblage or concatenation of principles and conclusions; or the whole of any doctrine, the several parts of which are united together, and follow or depend on each other, as a system of astronomy, (see *Copernicus*, *Ptolemy*, and *Tycho Brahe*,) a system of the planets, a system of philosophy, &c.

SYSTEM OF PULLEYS. A number of pulleys united together with one rope over all, so that all the pulleys unite to produce the effect required. (See *Pulley*.)

SYSTILE. The manner of placing columns where the space between the two shafts consists of two diameters.

SYZYGY. A term equally used for the conjunction or opposition of a planet with the sun.

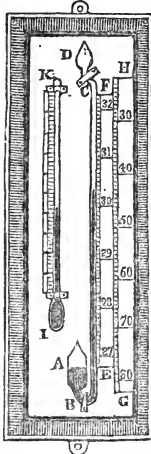



The twentieth letter of the English alphabet, a lingual letter, and a mute, having a sound very similar to *d*, but uttered with a sharper emission of the breath. Combined with *h*, it has two other sounds, as in

the words *this* and *thing*; the former is a sound between *d* and *t*; the latter between *t* and *s*; so that foreigners whose native language does not contain these sounds, often say *dis* and *sing* for this and *thing*; or, *noosing* for nothing. T is used as an abbreviation on monuments, &c., for Titus, Titius, Tullius, &c. In music, T signifies *tenor*; also *tace*, to indicate silence; and in concerts it is also the sign of *tutti*, a direction for the whole band to play after a solo. In the arts, it is used as a word to denote things of the form of this letter as a capital; thus we say a T square; the T piece of a Stanhope press; a T bandage; or the T palace at Mantua.

TABBY. A kind of rich silk, *watered*, that is, passed between metal rollers variously engraved, which bearing unequally on the stuff, renders the surface unequal, so as to reflect the rays of light differently, making the representation of waves thereon.

TABLE. In mathematics, is a series or system of numbers methodically arranged, for the more ready calculation of various problems in annuities, astronomy, logarithms, &c. *Astronomical* tables are computations of the motions and other phenomena of the heavenly bodies. *Tide* tables give the time of high water at the places for which they are made. *Meteorological* tables are a register of the state of the weather, temperature, dryness, &c. at the time that the tables are kept. *Chemical* tables, and others relative to natural philosophy, contain generally a comparative account of various classes of substances, or of different conditions of the same substance.

TABLE, or TABLET. In architecture, &c., a flat surface charged with any ornamental device.

TABLE, Corbel. (See *Corbel Table*.)

TABLE, Water. A coping or flat stone or stones placed on the top of the various stages of buttresses, tops of battlements, &c., to throw off the wet.

TABLE DIAMOND, or other precious stone, is one whose upper surface is quite flat, and the sides cut in angles; in which sense a diamond cut table-wise is used in opposition to a faceted diamond, which is cut in facets, coming to a point in the front, and a rose diamond, which is of a smooth regular surface.

TABLE MICROSCOPE. Any microscope adapted to stand upon or to be fastened to a

table; the term being used not as expressive of any particular kind of instrument, but in contra-distinction to those small microscopes which are held in the hand.

TABLE OF GLASS. In glass works, and among glaziers, a circular plate of window glass, being the original form in which it is cast.

TABLET. The same as table.

TACAMAHAIC. A peculiar resin extracted from a particular species of poplar. It has much the scent of benzoin and musk combined.

TACHOMETER. An instrument invented by Mr. Donkin, to indicate the velocity of machinery. It is represented below. A B is a glass tube open at both ends; it is fixed to an upright board, and dips into the cup C, but is not connected with it. The cup C passes through a socket at D, and is united with the pulley E. A cord passes over this pulley, and over another pulley attached to some part of the machinery. C is partly filled with mercury, and the glass tube partly filled with colored spirits of wine. When the cup is whirled round, the mercury, by centrifugal force, is collected about the edge of the cup, leaving a cavity towards the centre. This occasions the spirits of wine to sink in the tube, and as the bore of the tube above the cup is much less than that part in the cup, (for every inch that the mercury falls, the spirits of wine falls several inches;) and as the centrifugal force is in proportion to the rapidity of motion given to the cup; and its sinking, and that of the spirits of wine in proportion to the sinking of the mercury, it is evident that by attaching a scale to the long tube, the velocity of the motion of the machinery will be easily and accurately indicated.

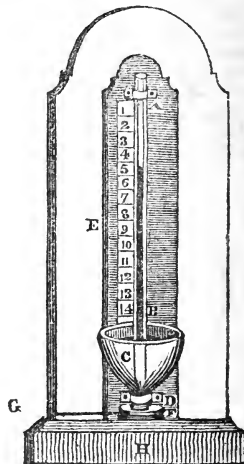

TACKLE. Another name for a pulley, or system of pulleys. *Ground tackle* implies anchors, cables, and buoys.

TACTION. Touching or tangency.

TAFFETY. A very rich, glossy, silk stuff; plain, flowered, gold striped, &c.

TAIL IN. In carpentry, to fasten any thing into a wall at one end, as the steps of a stair, a bracket, &c.

TAIL WATER. Water which impedes a water wheel.

TALC. A well-known and widely-diffused species of mineral, remarkable for its perfect capability of cleavage, as it may be split into laminae much finer than the thinnest paper. The finer kinds are perfectly transparent, and are used by the Russians, instead of glass, for windows. We have also a great consumption of it for the tops of the boxes, containing the mariner's compass needle, and for mounting microscopic objects. When pounded, it is used along with carmine or safflower for rouge; also, to communicate a flesh-like softness to plaster figures, and other minor purposes.

TALLOW. Animal fat, melted and separated from the fibrous matter mixed with it.

TALON. The same as ogee.

TALUS, or TALUT. The same as batter, (which see.)

TAMBOUR. The vase or naked part of a Corinthian or Composite capital, and on which the ornaments are supposed to rest. Also, the wall of a circular temple when surrounded with columns. Also, a lobby or vestibule, inclosed with folding doors, to break the current of wind from without, as at the entrance of churches, banking houses, &c.

TAMBOUR. A species of embroidery, in which threads of gold, silver, colored silks, &c., are worked by needles of a peculiar form into flowers, leaves, or other ornamental objects, upon a silk stuff, stretched over a circular frame, called a tambour.

TANGENT. A line which touches a circle or other curve without cutting it, extending however only on one side. Thus, in the following figure, C C C and other lines are tangents to the circle.

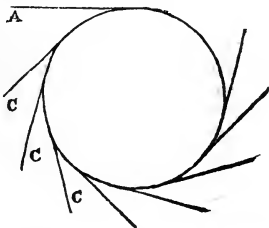

In a circle, a tangent is perpendicular to the radius at the point of contact; that is,

A B is perpendicular to B C; also $A B^2 = A E \times A F$; or A B is a mean proportional between A E and A F.

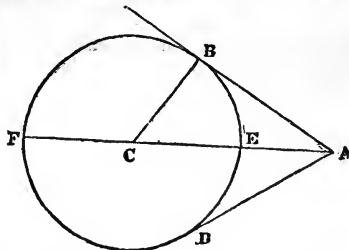

Tangent, in trigonometry, has a more limited meaning. It is a right line touching one extremity of an arc, and limited between that point, and its intersection with the secant passing through the other extremity. Thus A G is the tangent to the arc B A, and also to the arc which forms all the rest of the circle A C B, and A H is a tangent to the arc A K; and also, as in the other case, it is tangent to the rest of the circle A B C K. So also L M is the tangent to the arc L B, or the co-tangent to A B. Hence the tangents in the first and third quadrants are positive, in the second and fourth negative; that is, they are drawn in an opposite direction to the former. Also the tangent of 0° is zero, or nothing, but the tangent of 90° is infinite; so likewise the tangent of 180° is zero, but of 270° infinite.

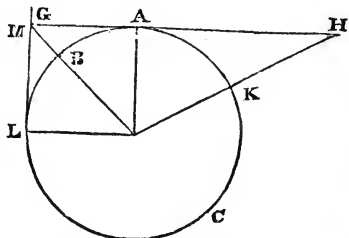

TANGENTS, Artificial. A term used by some authors to denote the *logarithmic* tangents, in contra-distinction to *natural* tangents, or the absolute tangents to any given radius.

TANGENTS, Method of. Is a method of drawing tangents to any algebraical curve, or of determining the magnitude of the tangent and sub-tangent; the equation of the curve being given.

TANGENTS, Inverse Method of. This is the reverse of the foregoing, and consists in finding the nature of the curve that has a given sub-tangent.

TANGENTIAL FORCE. Any force which acts so as to give a tendency to any body to

fly off from the centre. Thus mud from a wheel, water from a mop, and a stone from a sling, are thrown off at a tangent from the rotative body. So also would the planets, which are acted upon by the same force, the centrifugal, be thrown off into infinite space were it not for the power of gravitation which restrains them.

TANK. Any large square or oblong vessel, whether formed of wood, stone, or metal, adapted to hold a liquid.

TANNATES. Combinations of the tannic acid and metallic solutions. The tannates are mostly insoluble.

TANNIC ACID, or TANNIN. A peculiar vegetable principle, so named because it is the effective agent in tanning. It is found in considerable quantities in oak bark, sumach, nut galls, fern roots, willows, and other vegetables. It is owing to the existence of tannin that leather tanned with it for a long period is so impervious to wet, and so much more durable than untanned skins.

TANNIN, Artificial. A species of tannin may be formed artificially, by digesting charcoal in dilute nitric acid for several days. It is at length dissolved, and a reddish brown liquid is obtained, which furnishes, by careful evaporation, a brown, glossy substance, amounting to about 120 parts to every 100 of charcoal. This is soluble in water and alcohol.

TANNING. A chemical process, by which the hides and skins of various animals, particularly those of neat cattle, are made into a hard and durable leather.

TANNO-GELATINE. The white precipitate which is formed when tannin is added to a solution of gelatin.

TANNOUS ACID. The tannin of catechu, which is said to contain less oxygen than the tannin from oak bark.

TANTALUM. A metal, otherwise called columbium, (which see.)

TANTALUS CUP. A siphon so adapted to a cup, that the short leg being in the cup, the long leg may go down through the bottom of it. When a liquid is poured into the cup, it will rise in the cup until the height of it is above that of the bend of the siphon, when the siphon will begin to act, and the whole of the water run out. It is called Tantalus cup, because the siphon is usually concealed by a small figure endeavouring to drink, but who is foiled, for immediately the water reaches his mouth it flows away.



TAPERING. A term expressive of the nature of a solid, contained between two or more opposite planes inclined towards each

other, or inclosed by a surface which is narrower at one end than at the other. Thus the wedge, the pyramid, the frustrum of a pyramid, the cone, and the frustrum of a cone, are all tapering solids.

TAPESTRY. A kind of woven hangings, of wool and silk, frequently raised and enriched with gold and silver, representing figures of men, animals, historical subjects, landscapes, &c.

TAPIOCA. A kind of starch, procured by the Brazilians from the root of the cassava plant.

TAPPETS. The small levers which are connected with the valves of the cylinder of a steam engine, and which are worked by the air-pump rod. (See *Steam Engine*.)

TAR. A well-known substance, obtained chiefly from the pine by burning it in a close smothered heat. Some of the unctuous species of bitumen are also called mineral tar, and during the manufacture of coal gas a tar exudes from the coals, and is deposited in a receiver, called the tar vessel. This is *coal tar*.

TARE AND TRET. A rule in arithmetic, which ascertains the allowance to be made on any goods on account of the weight of the packages, dross, &c.

TARPAULING. A broad piece of canvas, well daubed with tar, and used to cover the hatchways of a ship at sea, to prevent the penetration of sea water. Tarpaulings are used for similar purposes on shore.

TARRAS, or TERRAS. A volcanic earth, similar to that of puzzolana, which, when calcined and mixed with sand and water, makes a hard and durable mortar, applicable particularly to stand in situations under water.

TARTAR. A substance deposited on the sides of wine casks, during the time that the wine is in a state of fermentation. This substance being scraped off, and in its natural and unpurified state is called by chemists bitrate or supertartrate of potass, and popularly crude tartar. When this is purified by solution, crystallizing, and boiling along with a clayey earth, it is known as *cream of tartar*, or the acidulous tartrate of potass, or purified tartrate of potass.

TARTAR, Boraxated. When borax is added to tartar, it becomes much more soluble. It is then called boraxated tartar, *Le Fevre's* soluble cream of tartar, or *sal gummosum*.

TARTAR, Emetic. The tartrate of potass and antimony.

TARTAR, Regenerated. The acetate of potass.

TARTAR, Salt of. The sub-carbonate of potass.

TARTAR, Salt of, per deliquum. The sub-carbonate of potass, liquified by a small quantity of water or by exposure to the air.

TARTAR, *Secret Foliated Earth of*. Acetate of potass.

TARTAR, *Soluble*. The neutral tartrate of potass.

TARTAR, *Soluble Cream of*. (See *Tartar Boraxated*.)

TARTAR, *Vitriolated*. Sulphate of potass.

TARTARIC ACID. An acid obtained from tartar, by boiling it in water, and saturating its potass by sulphuric acid. This, by continuing the boiling will fall down, and the supernatant liquid being poured off, boiled to the consistence of a syrup, and set aside, deposits crystals of tartaric acid, equal in weight to half the tartar employed.

TARTARINE. The name given by Kirwan to the vegetable alkali or potass.

TARTARIC ETHER. An ether formed by distilling together 5 parts of tartaric acid, 7 of alcohol, and 2 of sulphuric ether.

TARTRATES. Neutral compounds of the tartaric acid with a base.

TASSELS. The brackets or pieces of wood which sometimes support the mantle shelf in common buildings.

TAWING. The preparation of white leather.

TEAK. A valuable timber, which abounds in various parts of the East Indies, and is applied to domestic and nautical purposes. Ships built with teak are far more durable than those built of English oak.

TEASEL. The head of a plant, called *dipsacus fullonum*. It is employed to raise the nap upon cloth; a number of the prickly heads being fastened to a wheel, to which a rapid motion is given by hand or by machinery, and the cloth when dyed being placed beneath the wheel, the points or hooks of the teasels catch the finer fibres of the wool, and draw them in one direction, which constitutes the nap of the cloth.

TECHNICAL. Signifies in general that which belongs to any art, or to any branch of it in particular. A *technical* term is an expression peculiar to any art or profession. In the fine arts, the *technical* comprises every thing relating to the material execution of works of art.

TECHNOLOGY. The science which treats of the arts, particularly those which are mechanical.

TEINT. (See *Tint*.)

TELAMONES. The images of men supporting a cornice or entablature.

TELEGRAPH. A name given to any instrument, by means of which intelligence can be rapidly communicated to a considerable distance. There are numerous kinds of telegraphs in use; that at the Admiralty, in London, consists of a perpendicular post, bearing six arms, as represented in the cut. Each of these is worked by a cord, and may be folded up within the post, or directed to three different positions; oblique upwards, hori-

zontal, and oblique downwards. The changes that may be made by them is therefore almost endless; and if certain words, numbers, or phrases, are attached to each position of the arms, it is evident that the intelligence may pass as rapidly as the boards or arms can be moved. The figures show the telegraph with all the arms extended, and also a variety of the positions into which it may be put.

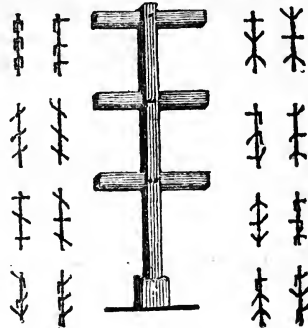

TELEGRAPH, *Electrical*. A means of rapid communication by the science of electromagnetism. It is known that when a current of electricity passes around a magnet, it occasions that magnet to diverge from its former position in proportion to the strength of the current. In the electrical telegraph, a current is sent along a wire inclosed in a waxen or resinous material to keep it dry and insulated, from one station to another, where it acts upon several magnets, in accordance to a similar set of magnets at the first station. According to the manner in which it acts upon these, driving them to the right or left, more or less, it is instantly known what it is intended to communicate.

TELEGRAPH, *Pneumatic*. (See *Pneumatic*.)

TELEGRAPHIC ALARM. (See *Magnetic Alarm*.)

TELESCOPE. An optical instrument employed in viewing distant objects. Telescopes are either refracting or reflecting; the former consists of different lenses, through which the objects are seen by rays refracted by them to the eye; and the latter consists of lenses, and also mirrors, from which last the rays are reflected to the eye. The lens or glass turned to the object, is called the object glass, and that next the eye the eye-glass; and when the telescope contains more than two lenses, all but that next the object are called eye-glasses. The simplest of all telescopes is that used for observations by night, called the astronomical telescope, and which is described under *Night*. The telescope used by day, and upon ordinary occasions, contains three lenses; or if of four lenses, those two next the eye act as one only—

they are but of half the thickness a single lens would needs be in that situation. The reason that two lenses are here used as one, is to obviate as much as possible the effects of spherical aberration. The action of the ordinary day telescope is as follows:—Suppose the rays from A B strike the object glass C D; they are refracted and form an inverted image of the object at the focus; they then strike the second glass E F, and passing off in parallel lines strike the third glass G; here the image appears erect, and thence proceeding to the last glass H, the rays are not again inverted, because the eye is placed within, and not beyond the focus.

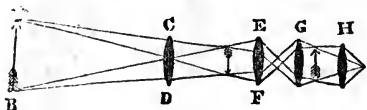

For other telescopes, (see *Cassegrainian, Gregorian, Galilean, Newtonian, and Night.*)

TELESCOPE, Achromatic. A telescope, the eye-glass of which is achromatic.

TELESCOPE, Catadioptric. The same as reflecting telescope.

TELESCOPE, Dioptric. The same as refracting telescope.

TELESCOPICAL. Belonging to a telescope; seeing at a distance.

TELESCOPIC, or TELESCOPICAL STARS, are such as are not visible to the naked eye, but only seen by means of a telescope.

TELLURATES. Combinations of the telluric acid.

TELLURETTED HYDROGEN. A gaseous combination of tellurium and hydrogen, which may be made by submitting an alloy of tellurium and tin to the action of hydrochloric acid. It reddens litmus, dissolves in water, and possesses the general habitudes of sulphuretted hydrogen.

TELLURIC ACID, or PEROXYDE OF TELLURIUM. When the tellurous acid is deflagrated with nitre, it is converted according to Berzelius into telluric acid. It contains half a proportion more oxygen than tellurous acid.

TELLURION. An instrument for showing the effect of the earth's motions and the obliquity of her axis; the one occasioning the seasons, the other the succession of day and night. A is a lamp, representing the sun. B a pasteboard globe, showing the earth; this is set at an angle of $23\frac{1}{2}^{\circ}$ with the perpendicular. The axis fits loosely into a socket I, and bears a wheel H; this works in another wheel G, which is fixed to the pulleys K and M. C is a stand that bears at various heights the multiplying wheel D, the cross bar of wood E, the pulley I, and the lamp A. C, D, I, and A being fastened

together, but E turning round. An endless cord passes from K to I, and another from M to D. Turning the shaft E O around its centre by the end O, gives the earth a motion like that of its annual revolution around the sun; at the same time it turns on its axis, owing to the wheel D working the pulley M, that the wheel G, and G the wheel H. This shows the cause of the succession of day and night, the earth being supposed to turn round once in 24 hours. It has moreover a third motion, by means of the short cross bar I, which moves loosely on the arbor of G. The pulley being fixed to I, and a cord passing round the equal sized pulley K, the earth will turn round G once in the whole revolution around the sun, and present its axis in a different manner to that luminary. As represented in the cut, it would show the winter solstice; after a quarter of a revolution it would represent the position of the axis at the vernal equinox; at another quarter, the summer solstice, when the north pole would be illuminated; and three months afterwards the autumnal equinox would be shown; thus explaining the nature of the four seasons, and showing that they arise from the obliquity of the earth's axis.

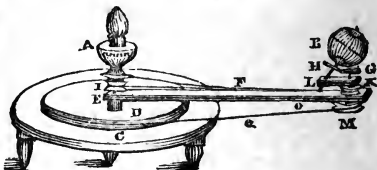

TELLURIUM. A rare metal discovered in an ore of gold by Klaproth, in 1798. It is of a silver white color, brilliant with a laminated texture, brittle, and melts at a temperature a little higher than lead does. It combines with oxygen in two proportions, forming tellurous and telluric acid. It also unites with chlorine, hydrogen, sulphur, and iodine.

TELLUROUS ACID, or OXYDE OF TELLURIUM. A combination of 1 atom of oxygen to 1 of tellurium. It is procured by burning tellurium in the air; it is of a yellowish white color, and of a peculiar odour.

TEMPERATURE. Implies that degree of sensible heat which a body possesses when compared with other bodies. The temperature of bodies is ascertained by means of the thermometer, æthioscope, pyroscope, pyrometer, &c.

TEMPERING. The art of altering the existing degree of elasticity of metals. For example, steel is rendered more or less soft or hard, or more or less brittle or elastic, according to the degree of tempering given to it. Tempering is performed by heating the metal in the fire, and afterwards cooling it more or less rapidly.

TEMPLATE. A sort of guide, used in cutting and placing masonry and stucco work. It is a thin iron plate, upon the edge of which is cut the reverse of the various mouldings or indentations which the stone is to be worked with, so as to form an exact counterpart to it. Thus the workman, applying his template from time to time, can ascertain how the work proceeds. In laying on plaster or cement cornices, mouldings, string bands, &c., the template is furnished with a back, fixed at right angles to the plate. By laying on the liquid plaster, and running the template along steadily, the back resting against a straight edge, the plaster is left at the indentations, but carried forwards where the template of iron touches it.

TEMPLET. A short piece of timber or a large stone placed in a wall, to receive the end of a girder, breastsummer, or other large beam of timber.

TEMPLE. A building appropriated to religious uses.

TENACITY. In natural philosophy, is that quality of bodies by which they sustain a considerable pressure or force without breaking, being the opposite quality to brittleness or fragility.

TENDER. The name given to the waggon which accompanies a locomotive engine, for the conveyance of fuel and water.

TENON. A projecting rectangular prism, formed on the end of a piece of timber, to be inserted in a mortice of the same form.

TENSION. The quality of being stretched beyond that length which a thing retains in ordinary circumstances.

TENSION BRIDGE. (See *Bowstring Bridge*.)

TENTER, TRIER, OR PROVER. A machine or frame, used in the cloth manufacture, to stretch out the pieces of cloth, and make them set even and square. It is a very long frame-work, or posts and rails; the lower rail lifting up and down, and both of them being furnished with tenter hooks, upon which the cloth is held by its selvages.

TER. As a prefix to chemical and other words, signifies three proportions of that substance to which the *ter* is affixed to each one of the base. Thus the tetroxyde of osmium consists of 1 atom of osmium and 3 of oxygen. The terchloride of chromium has 3 parts chlorine to one of chromium, and so on for other compounds.

TERM. In geometry, the extreme of any magnitude, or that which bounds or limits its extent, thus the terms of a line are points; of a surface are lines; and so on. Terms of an equation or of any quantity in algebra, are the several members of which it is composed, separated from one another by the signs + or -. Thus $a^2 + ax + a^2$ is said to consist of three terms.

TERMINAL VELOCITY. In the theory of

projectiles, is the greatest velocity which a ball can acquire by descending vertically in air; and with which, when attained, it would descend uniformly, if no solid obstacle destroyed the motion.

TERMINATOR. In astronomy, the earth being a ball, one half of it is always illuminated by the sun; the other half is in darkness. The line which intervenes between the light and darker sides is popularly called the terminator.

TERMINUS. As applied to a railroad, is the place of starting the trains, and the termination of their journey; intermediate places of stopping being called *stations*. In architecture, a terminus is a trunk or pedestal, adorned at the top with the figure of the head of a man, woman, satyr, or animal, whose body seems to be inclosed in a trunk, as in a sheath, which usually tapers downwards. Termini are used for the support of interior cornices, &c., and other purposes of internal decoration.

TERRA. The earth.

TERRA COTTA. Baked earth. Earth or clay was the first matter employed by artists, whether in building or modelling; and at much more recent periods, was abundantly used for the latter purpose, and is the substance of many beautifully executed *vassi relievi*, of which relics and examples have been found among the ruins of Herculaneum, Pompeii, and other places. In fact it is greatly used at the present day for constructing architectural ornaments, &c., it being plastic, cheap, readily worked, and at the same time hard and durable.

TERRA PONDEROSA. Heavy spar.

TERRA SIENNA. A kind of umber or brown iron ochre, used as a pigment. In its natural state it is of a light, transparent, yellowish brown, and is called *raw sienna*. When submitted to the action of fire, it becomes much more red. It is then the fine color known as *burnt sienna*.

TERRA VERTE. A green earth, used as a pigment. It is a good glazing color, being of thin body.

TERRACE. An area raised before a house for walking upon.

TERRACE ROOF. Those which are flat like terraces.

TERRAQUEOUS. An epithet applied to our earth when considered as consisting of land and water.

TERRESTRIAL. Any thing relating to the earth, as Terrestrial globe, line, &c.

TERRESTRIAL GLOBE. (See *Globe*.)

TERRESTRIAL MAGNETISM. (See *Magnetism*.)

TESSELATED PAVEMENT. A pavement of mosaic work, made of small square dies or tesserae of burnt clay or hewn stone, arranged as to color so as to form an extremely orna-

mental pavement. Various ancient specimens of these have been from time to time exhumed in different parts of England; two very lately, 14 feet below the more modern pavement of the French Church, Threadneedle Street. The figure of a part of one of these is seen below, the different shading showing a difference of color. Tessellated pavements are almost wholly the work of the Romans, and are not to be confounded with the quarried or the particolored marble pavement of more modern times.

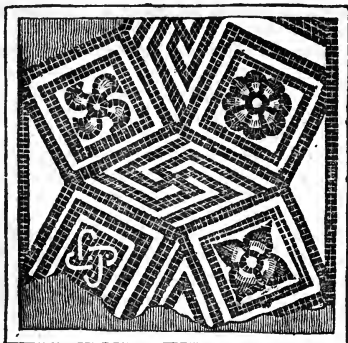

TESSERA. The name of any small square or cubical piece of wood, stone, baked clay, or other material, formed for various purposes among the Romans; but more especially the cubical bodies used to form tessellated pavement, and which were somewhat about an inch in length and breadth, and somewhat more in thickness. (See *Tessellated Pavement*.)

TESTS. A standard by which the certain character of any thing may be ascertained; in which general definition the word test applies to all subjects and sciences. In a limited sense, it is used in chemistry to denote those re-agents which act in a peculiar manner upon some substances, and not in the same way upon others. Thus they afford criteria by which simple as well as compound bodies may be distinguished. For example, suppose you have a salt, of the nature of which you are ignorant, but which you suppose to be copperas or the sulphate of iron. You may prove it by various tests; for example, add a little muriate of barytes, if this occasion a white precipitate, you prove one part, and show that the substance contains sulphuric acid; then add a little tincture of galls, and if it turns the solution of a black or dark purple color, it shows iron to be present, because no metal will be rendered black by galls but iron; it is therefore a sure test. Other tests apply to other bodies.

TEST OBJECTS FOR MICROSCOPES. Those objects which are selected as most appropriate to test the discerning power of the compound

microscope; the perfection of the instrument being ascertained by its rendering clearly visible the various markings or structure of the object. The chief tests are the dust or scales from the wings of several kinds of butterflies, as the menelaus, the white cabbage butterfly, the small brown house moth, the scales of the diamond beetle, and best of all the scales of the *Podura*, or spring-tail insect. Among opaque objects are to be reckoned the hair of the bat and of the mouse. The figures on the enamelled dial plate of a watch determine the quantity of chromatic or spherical aberration in a lens.

TEST PAPERS. Pieces of thin soft paper, stained with various chemical substances, to be used instead of solutions of the various tests; it being more convenient to dip a paper in the subject to be tested than to use a solution of it.

TEST TUBE. A small tube of glass, closed at the lower end and rather widened at the top. The use of them is to hold small quantities of any solution, in order that it may be tested by necessary re-agents, and for other purposes, in chemistry. Test tubes are usually placed in a stand, from which they are taken out at pleasure.

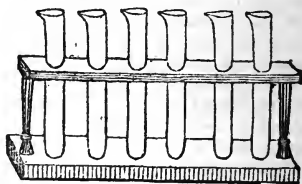

TEST TUBE HOLDER. A contrivance of an extremely simple nature, having for its object the holding of a test tube, that a spirit lamp may be placed beneath it, during any operation that requires heat to be applied to it for a continuance, as is requisite in making various solutions and combinations. It may be made of wood, with a spring of tin, as represented below.

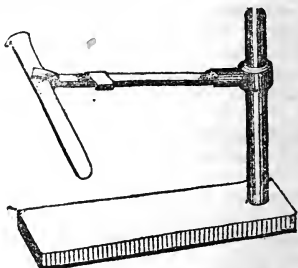

TETRA. Any thing in which a part of it occurs four times, as a tetrasulphuret, where there are four proportions of sulphur.

TETRAGON. A figure of four angles, whether a square, rectangle, trapezium, parallelogram, rhombus, or rhomboid.

TETRAHEDRON. One of the five regular bodies. It has four equal triangular faces.

TETRASTÖÖN. A court yard, with porticoes or open colonades on each of its four sides.

TETRASTYLE. A building having four columns in front.



TEXTILE FABRICS. Any thing woven, such as muslins, calicoes, silks, lace, &c.

TEXTURE. Degree of strength, evenness, elasticity, or other property in a body, by which it may be indicated; thus we say the texture of a mineral may be fibrous or lamellar, or have some other property.

THAUMATROPE. The name given to a little amusing optical toy, whose effects are founded upon the well-known principle, that an impression made on the retina of the eye, lasts for a short interval after the object which produced it is withdrawn. It consists of a card with two opposite strings; on each side of the card a device is introduced, and when the card is rapidly whirled round, the figures on each of its sides are presented with such quick transition that they both appear at the same instant, and thus occasion a very striking and magical effect. For example, depict a mouse on one side the card and a mouse-trap on the other, upon being whirled round, the mouse will appear within the trap.

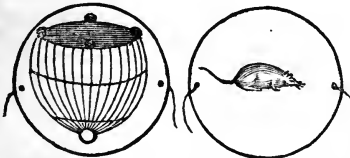

THAW. Such an increase of temperature as will restore frozen bodies to a state of fluidity or suppleness.

THEATRE. A building used for the performance of plays and other scenic representations; also any place where lectures are given to a large audience; or a room adapted to convey impressions from a distant part to the eye, ear, &c. in the best manner.

THEATRICAL FIRES, are those compositions used at the theatres to increase the effect of conflagrations, incantation scenes, &c., by a strong red, blue, or other colored fire. The compositions are as follow:—
Red: Dry nitrate of strontian, $1\frac{1}{2}$ oz.; sulphur, 3 dr. 6 gr.; chlorate of potass, 1 dr. 12 gr.; sulphuret of antimony, 2 dr.; char-

coal, 1 scruple. First pound the chlorate, then mix it carefully on paper with the other ingredients, previously pounded. *Blue:* Nitrate of barytes, 77 parts by weight; sulphur, 13 ditto; chlorate of potass, 5 ditto; realgar, 2 ditto; charcoal, 3 ditto. To fire either of the above, lay them on a sheet of tin, and apply a lighted match. A colored flame is also often wanted; (for various of them see *Fire*.)

THEBAÏA. An alkaline property existing in opium. It has not been applied to any use, and exists in a very minute quantity

THEIN. A peculiar principle in tea, from which it derives its flavor and exhilarating properties.

THENARD'S BLUE. Phosphate of cobalt, formed by the double decomposition of phosphate of soda and chloride of cobalt, calcined with twice as much pure alumina at a white heat.

THEODOLITE. An instrument employed by surveyors for measuring angles, whereby to compute the heights, distances, &c., of remote objects. A B, in the figure beneath, is a small telescope, which is made capable of a vertical motion around the centre C. The frame work which supports the telescope, also supports the segmental scale E D, which is divided into degrees of a circle. Upon raising or depressing the end A of the telescope, the scale will, of course, be equally moved, and as the hand F stands at O, when the telescope is horizontal, the proper angle of its elevation will be indicated by the same hand F, when the end of the telescope is raised or depressed. Thus the height of any object in angular measurement may be ascertained, and by this, and other measurements, its true height may be afterwards found by trigonometry. If it is desired to ascertain the magnitude of a horizontal angle, it may be done with equal facility by another motion

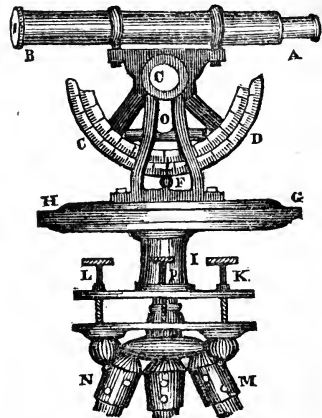

the instrument has ; this is around or within its centre pin or support I, at the same time the table G H remains fixed. This table is graduated with a circular scale, in segments of 180° each ; a hand upon the moving part of the instrument will at once indicate the degrees passed over by the telescope when turned horizontally from one point to another. K L P are three tangent screws, for the adjustment of the instrument in a perfectly horizontal position, and which is proved by the spirit level O, and another running at right angles to it, the end of which is seen at F under the hand. M N is the end of the tripod stand, upon which the theodolite usually stands when in use.

THEOREM. A proposition to be proved. (See *Proposition.*)

THEORY. A rule, or set of rules or observations, for the explanation of any art or science, or for the better understanding any doubtful fact or phenomenon. It stands opposed to practice, or the performance of what theory teaches.

THEORY OF NUMBERS. A modern branch of analysis, which has for its object the investigation of certain properties of numbers, such as the sum of two odd squares cannot make a square number, that every number is composed of four or a less number of squares, &c. &c.

THERMAL. Hot or occasioned by heat, as thermal or hot springs.

THERMO-ELECTRIC CIRCUIT. A combination of two metals, in distinct pieces, to which heat being applied at one end of each, they being united together by twisting or soldering, the electricity of those pieces is thereby disturbed, and the other ends being connected with the cups of a galvanometer, the disturbance becomes visible by its effects upon the magnetic needle. Suppose A B to be a galvanometer ; C D two wires, one of platinum, the other of copper or silver, which wires dip at one end into the cups A and B, and are twisted together at E. If a spirit lamp, hot ball of metal, flame of a candle or other hot body, be held for a moment under E, a thermo-electric current is established, and it will be seen to cause considerable divergence of the magnet of the galvanometer.

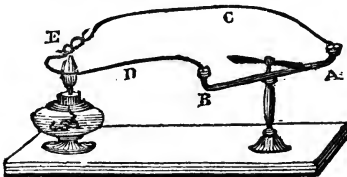

This experiment may be varied by a compound rod of metal, as seen below. A is a rod of bismuth, 4 or 5 inches long, with a

wire soldered in one end, and terminating in a mercury cup D. B is a rod of antimony, of like size, and also furnished with a wire and cup E. The two dissimilar bars are soldered together at C, and the whole may be supported upon wires. If D and E are connected with the poles of a galvanometer, and a spirit lamp is placed for a moment under C. The effect upon the galvanometer will be the same as in the former instance.

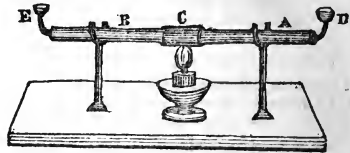

When the several pieces of each of the two chosen metals are united in pairs, and those pairs joined together, or else so placed as to act in unison, a correspondingly greater effect is produced, and the instrument may then be called a thermo-electric battery ; such a one is described under the word *Melloni*. Also the magnetic needle may be placed so as to be affected by the metals themselves, without the aid of the galvanometer. The converse, as may be witnessed by the following instrument, which is also a simple circuit or circle. Let A B be a bar of antimony, bismuth, tin, lead, or zinc ; and C D a strip of copper, bound on to the ends of A B by copper wire. E is a delicate astatic magnet, suspended on a point, projecting above the bar of metal. When heat is applied to the end, the magnet will be deflected on one side ; if heat be applied to B, A being at the same time cool, the magnet will turn to the contrary side.

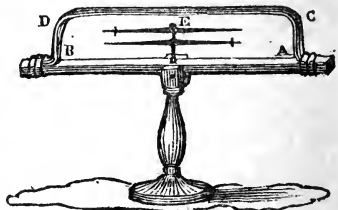

THERMO-ELECTRIC PILES. (See *Melloni*.)
THERMO-ELECTRIC RECTANGLE. (See *Marsh*.)

THERMO-ELECTRIC THERMOMETER. A contrivance of Mr. Solly, to ascertain the temperature of apartments, fire-places, &c. It is exactly similar in principle to the first described thermo-electric circuit, consisting of two wires, one of iron, the other of copper, twisted together at one end, and that end

placed in the furnace, or other place to be tested. The wires are long enough to reach to a distant apartment, of which the temperature is uniform, where the ends of the wires are connected to a galvanometer, to which a scale of degrees is attached. As the furnace varies in temperature, so will the galvanometer indicate the changes that occur. The reason the wires are so long is, that one end may remain cool, however hot the other may be made.

THERMO-ELECTRICITY. A portion or department of the general science of electricity, which explains the effects which arise when electric currents are put in motion by means of heat, as explained, when treating of the various apparatus, under the words *Melloni, Marsh, Seebeck, Thermo-electric Circuit, &c.*

THERMO-ELECTRICS. Metallic bodies, the union of which show the effects attributed to thermo-electricity. The following arrangement considers each as positive to those below it, when a single pair only is used; but negative to all below it, when several pairs of metals are employed. Therefore to construct any thermo-electric apparatus, those two metals will cause the greatest effect which are *farthest* from each other in the list. Galena, bismuth, mercury, nickel, potassium, palladium, cobalt, manganese, tin, lead, brass, rhodium, gold, copper, silver, zinc, cadmium, plumbago, iron, arsenic, antimony.

THERMO-ELECTROMETER. (See *Clarke.*)

THERMOMETER. An instrument for ascertaining the exact degree of heat which any body possesses. The thermometer applies chiefly to the lower degrees of heat; for indicating high temperatures, the instrument is usually called a pyrometer. The ordinary thermometer consists of a narrow tube of glass, closed at the top, and with a much larger bulb below. This, and also a part of the tube, is filled with mercury, (or in other cases with colored spirits of wine.) The tube is fastened to a narrow board or piece of ivory or metal, which is so graduated as to form a scale, proceeding from the heat of boiling water, which forms the upper mark, to about 40° below the freezing point, so that the mercury ascends or descends as it becomes hotter or colder. As spirits boil at a much less degree of heat than water, the scale attached to spirit thermometers is less extensive. Brewing thermometers, and those attached to hot-houses, or to ascertain the state of the weather have a still more limited scale; the scale at all times being adapted to circum-

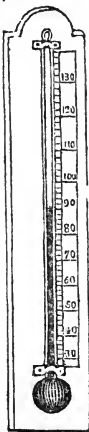

stances. The varieties of thermometers are almost endless; a *spirit* thermometer is one the bulb of which is filled with spirits of wine, colored with cochineal. This will ascertain degrees of cold greater than mercurial thermometers, but no degree of heat above 180°, as spirits of wine boil at that heat. The *mercurial* thermometer is filled with mercury, and is applicable to heats between 40° below zero on Fahrenheit's scale, when mercury freezes, up to 600° above the freezing point when mercury boils. An *air* thermometer or one containing a bulb of inclosed air, is, owing to its readiness of expansion and contraction, very serviceable to note sudden and trivial changes. (See *Air, Boyle, Leslie, Photometer, Æthioscope, Cryophorus, Differential Thermometer, &c.*)

THERMOMETER, Balance. (See *Balance.*)

THERMOMETER, Barometrical. (See *Barometrical.*)

THERMOMETER, Chemical. (See *Chemical.*)

THERMOMETER, Differential. Shows the difference of expansion in the contents of two tubes. (See *Leslie, Air, and De Butt.*)

THERMOMETER, Electrical. (See *Kinnersley.*)

THERMOMETER, Metalline. This is but another name for pyrometer. (See *Ferguson, Regnier, Crighton, Breguet, and Houriet.*)

THERMOMETER, Statical. (See *Cumming.*)

THERMOMETER SCALE. The graduated scale which is attached to the stem of a thermometer, in order that the degree of heat may be noted. Two points, one of water just boiling, the other of water on the point of freezing, universally form two points from which a scale of equal parts is constructed. Reaumur, whose thermometer is used in France, divided this space into 80 parts, beginning at zero. Celsius's, the Swedish, or centigrade thermometer, has the division of 100 parts, beginning also at zero; and Fahrenheit, whose thermometer is used in England, called the freezing point of water 32° above zero, and the boiling point 212°, or 180° above the other.

THERMOMETRIC HYGROMETER. (See *Leslie.*)

THERMOSCOPE. A term used most commonly as synonymous with thermometer, but differing from it in not offering to the eye the exact degree of heat or cold which influences it. It is, therefore, but an imperfect thermometer. Although this is the true meaning, yet thermometer and thermoscope are often used synonymously.

THERMOSTAT. The name of an apparatus for regulating temperature in vaporization distillation, heating baths and hot-houses, ventilating apartments, &c., invented and patented, in 1831, by Dr. Ure. It proceeds upon the principle of the unequal expansion caused by heat on various metals. The fol-

lowing will show three among very numerous applications of the instrument:—A, in the first figure, is a compound bar, made of a rod of steel and one of brass, united together. The end at A is fixed to the inside of a distern, boiler, or apartment, A M L. The end B is free to move downwards towards C, which it does when the temperature is raised, pulling down at the same time the lever D to which it is connected by the rod B, raising the contrary end to G, and with it any thing attached to the rod which hangs down from G. Suppose this is the damper I, it will raise it to H K, and if a regulator be fixed to N O, it will turn that also, and in either case may be made to regulate the temperature.

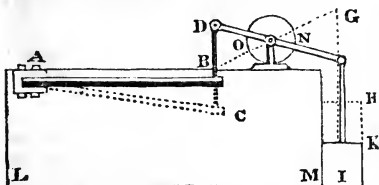

In the next figure, the metallic bars are separated by the block at A, where they are fixed. They are of unequal length, and their ends C and E act upon the cross links D and F, and through them upon the stop cock, inserted on the connecting link which joins these cross pieces. The cock will therefore be turned off or on in proportion to the widening of the end; thus hot water, air, steam, &c., may be admitted only as required.



In the next figure, the same principle is applied to the register of an air stove. There are two pair of bars connected in a manner similar to the last to cross links. The bars are brass and steel, as before, and form two pairs, the ends of each pair being united together. When cold, the bars are nearly straight; but as they become hot they bend, and by that flexure regulate the register.

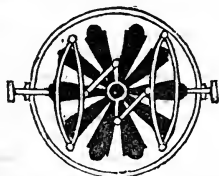

THOLOBATE. That part of a building on which a cupola is placed.

THORINA. A primitive earth, with a me-

tallic base, discovered in 1828, by Berzelius. It is extracted from the mineral thorite, of which it constitutes 58 per cent. When pure it is a white powder, without taste, smell, or alkaline properties. This earth consists of 74.5 parts of the metal thorium, combined with 100 of oxygen. It is of no known use in the arts.

THROTTLE VALVE. A contrivance to regulate the supply of steam to the cylinder of a steam engine. It is situated between the boiler and the cylinder. In locomotive engines it is worked by the engine man; in stationary engines by the governor. Its form and mode of action is as follows:—A is the valve inside the pipe. B, C, and D, are levers outside the pipe. B is connected by an axis with the centre of the valve. FG is the steam pipe. In the position shown, the valve rests quite across the pipe, consequently no steam can pass; but if the end E be thrust down, the end D will be raised in like proportion, and pulling up the end of B to which it is attached, will alter the direction of A, so that instead of standing up and down it will be turned sideways, and consequently an opening will be made on each side of the pipe, through which the steam will pass onwards.

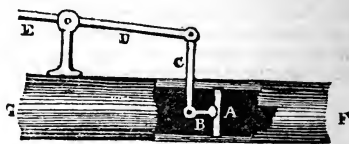

THOROUGH CARVED WORK. Carved work which is entirely cut through, better called pierced work.

THOROUGH LIGHTED. An apartment which has windows on two opposite sides.

THOROUGH STONES. Stones which extend quite from one side of a wall to the other.

THUNDER. The noise occasioned by the explosion of a flash of lightning passing through the air, or it is that noise, which is excited by a sudden explosion of electrical clouds, which are therefore called thunder clouds. Perhaps it may be better defined, as occasioned by the collapse of portions of the air which have been rent asunder by the passage of a flash of lightning.

THUNDERBOLT. When a thunder storm is at its greatest violence, and the lightning is so powerful as to occasion destruction to any object, it is said by the ignorant to be a thunderbolt, they cherishing the idea that a stone, or semi-metallic substance, at that time falls; and as if in evidence of the truth of the opinion, stones to which this name is given are often preserved. These have no connection with the phenomenon of thunder

and lightning, but are nodules of the sulphuret of iron: These are extremely common on the Downs in Sussex, Wiltshire, and other counties; so common indeed that they are collected by bushels for the manufacture of the sulphate of iron.

THUNDER HOUSE. An electrical apparatus in the form of the gable end of a house, made to show that the cause of injury to houses by lightning is the absence of a good and continuous conductor for the lightning from the summit to the ground. Suppose we take a board, like BB, made of baked wood, which is a non-conductor, as much so as the bricks of a house, and that we attach a wire C down the board; such wire being terminated above by a ball A, and below by a hook E, and having two interruptions in it, of an inch in space each, where we cut a square hole in the board to receive two small squares of baked wood, D and E; each square fitting very loosely, and having a wire down it. Placing the squares so that this wire unites all the ends of the long wire, as at E, of course the conductor would be continuous, and an electric shock sent down the wire would not disturb either square; but if one of the squares be placed so that its wire lies across the board, as is seen at D, then the whole conductor not being continuous, the shock will throw out the piece D, which has been placed across, exactly in the same manner as stones, bricks, &c., are thrown out from buildings by lightning.

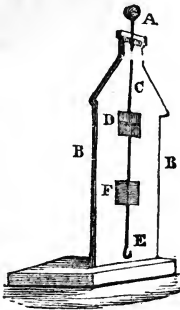

TIDE. A periodical motion of the waters of the sea, called also the *flux* and *re-flux*, or the ebb and flow. When the motion of the water is against the wind, it is called a *windward* tide; when wind and tide go the same way, *leeward* tide; when it runs very strong, it is called *tide-gate*. The tides are found to follow periodically the course of the sun and moon; hence we look to the attraction of these luminaries as their cause, particularly to that of the moon. The interval between two high waters is about 12 hrs. 25' or half of the moon's daily circuit round the earth. The tides have a particular reference

to the position and phases of the moon, and her distance from the earth. They have also a dependence upon the position of the sun and moon to the earth. To explain the cause of the tides, the following diagram will assist us:—

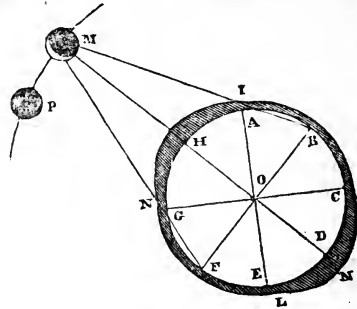

The larger body is the earth; the two smaller bodies are the moon in different positions. The earth is naturally within the sphere of the moon's attraction, in consequence of which the waters of the earth, (the only moveable part of it,) will be gathered together towards that side where the moon is placed, forming a prominent surface of water, as is represented at H, occasioning high water at that place, and consequently low water at B and F, because these are the parts from which the water is attracted. Now as the earth turns round on its axis in twenty-four hours, so it turns from beneath this accumulation of waters, and in six hours after high water the point H will turn round to A F, and consequently have low water. But the moon will during this six hours have gone a portion of her monthly course around the earth, and have arrived at P; therefore it will take rather more than six hours before H arrives at low water, so that two whole tides occur in 24 hours, 48 minutes, instead of twenty-four hours, and high water at any place is so many minutes later each succeeding day. The time of high water is not exactly when the moon is on the meridian of a place, but three hours after, because the waters being once put in motion cannot stop immediately; the cause which raised them is removed, but by their momentum they continue to rise for a considerable time afterwards. The reason why there are two tides in the day and not one, or why the waters are accumulated about N is said to be this, that the moon attracts the waters on the side nearest to her, away from the earth; and also attracts the earth itself away from the water on the contrary side. If therefore she attracted the waters nearer to her 40 feet, and the earth 20 feet, there would be an extra accumulation of 20 feet water on each side; that is at H and at N.

TIDE, Neap and Spring. These arise from the attraction of the sun, uniting with or opposing the attraction of the moon on the waters of the earth. The power of the sun's attraction to us is about $\frac{1}{2}$ that of the moon. Now at the time of new moon, the earth, moon, and sun, are in a straight line. See the following diagram, where S is the sun, and M the moon. If the moon attract the water 25 feet, the sun would attract 5 feet, and the whole tide would be 30 feet; and this being more than what is owing to the moon alone, it would be a *spring* tide. Next, suppose a week has elapsed, and the moon occupies the position B, then the sun and moon would oppose each other, and the rise of the waters would be less than ordinary. In the case we have supposed, the waters would rise only 25—5 or 20 feet, occasioning what is called a *neap* tide. The same thing would hold good at full moon, and at the third quarter.

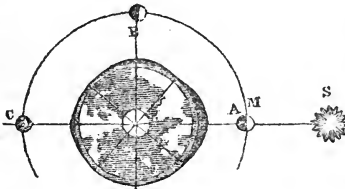

TIDE GAUGE. Any contrivance to ascertain the time of high water, or the height to which the tide rises at any place. The simplest tide gauge is a post with numbers at a foot distance from each other painted upon it. If it be desirable to ascertain the height of the water at any place inland, as at a distant observatory, a pipe must be laid on, one end of which extends to the water in the sea or river; then the pipe carried under ground, being at no part placed higher than the level of low water; its other end may terminate in a well, upon the sides of which a gauge of feet is painted. The water will rise and fall in the well in the same way as it does in the open sea or river.

TIDE, or GUARD LOCK. A lock situated between an entrance basin and a canal, harbour or river, and forming a communication between them. It is furnished with double gates, whereby craft can pass them either way at all times of the tide.

TIDE MILL. A mill which is moved by tidal water. Tide mills may be moved by the water rushing into a dam when the tide is rising, or when the water thus accumulated is afterwards flowing out, or both.

TIDE WHEEL. (See *Water Wheel*.)

TIE. Any thing to bind together what has a tendency to separate.

TIE BEAM. In a roof is that beam which

extends from one wall to the opposite, and connects together the lower extremities of the rafters.

TILE. An artificial stone or broad thin brick, made of dried earth, and burnt in a kiln, used in covering buildings or for paving. Tiles have various names, according to their surface, shape, use, or situation. Those of a rectangular form, with a flat surface, are denominated *plane* tiles and *crown* tiles. Those of a semi-cylindrical form are called *ridge* tiles or *hip* tiles. Others from their use are called *gutter* tiles, *paving* tiles, *drain* tiles, &c. The hollow-surfaced tiles used to cover houses are called *pan* tiles.

TILE CREAMING. Two rows of tiles placed horizontally under the coping of a wall, and projecting about three inches from the surface, for discharging the rain water therefrom.

TILTED STEEL. (See *Steel*.)

TILT HAMMER. A large hammer, lifted by machinery, to forge iron or steel. It is shown beneath. A is supposed to be a wheel, having upon its circumference a certain number of breaks; each of which catches hold of the lever F I, during its passage past it. C is a fly wheel, attached to A. B is an upright shaft, supported above the hammer, and upon which the hammer turns, as upon a centre of motion. It may, however, be supported by the strong frame work D. I is the head of the hammer. H the anvil. As the wheel A revolves, it presses down the end F with so sudden a jerk, that the under part of F strikes forcibly against the cushion G, in consequence of which the end A falls with considerably greater force upon the anvil than it otherwise would do.

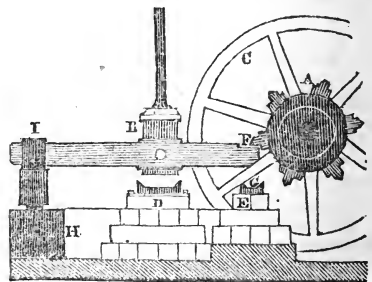

TIMBER. A term applied to trees after they are felled; also wood-work in general. The main beams of a house or other building, ship, &c., are usually called the timbers of it.

TIME. A certain degree of duration, marked by periods or measures, chiefly formed from the motions of the heavenly bodies; as a year, a month, and a day. It is necessary for various purposes to consider time as of several kinds. *Absolute* time has no reference

to objects or their motion, but has flowed on uninterruptedly and equably from the beginning of all things, and shall so pass on till the end, when time will merge into eternity. *Relative time* is the sensible measure of any duration, usually calculated by means of some standard of motion, as the course of one of the heavenly bodies, or the vibration of a pendulum. *Relative time* is distinguished into astronomical and civil. *Astronomical time* is that measured by the heavenly bodies only. *Civil time* is the former accommodated to civil uses, and formed into distinct periods, such as years, days, hours, &c. Again, astronomical time is either apparent solar or true; mean or sidereal. *Apparent solar time*, otherwise called *true time*, is that which is estimated by the sun's passage over the meridian of any place, and which is sometimes sixteen minutes sooner or later than that shown by a good clock. *Mean time* is the apparent solar time corrected to the average time or to the time indicated by the clocks. *Sidereal time* is that which is estimated by the passage of the same star over the meridian of any place, and which is the most exact measure of time we are acquainted with, the most accurate observations never having detected in it the least inequality.

TIME, Equation of. (See *Equation.*)

TIME KEEPERS. Any instruments used for measuring time; such are hour glasses, clypsydæ, clocks, chronometers, sun dials, &c.

TIN. A metal which in its pure state has nearly the color and lustre of silver. It is very malleable, exhales on friction a peculiar odour, is flexible, and when bent emits a crackling sound, called the *creaking* of tin. It melts at 442° Fahr. When heated it absorbs oxygen with rapidity, and changes finally into a white oxyde, called *putty* of tin.

TIN PLATE. A very thin sheet of iron, covered on both surfaces with tin, so as to be white and shining; for this reason often called white iron or tin plate. It is extensively used for what is commonly called tinware, such as saucepans, mugs, watering pots, kettles, &c.

TIN PLATE, Crystallized. (See *Moire Metallique.*)

TINNING. The art of covering another metal with a surface of tin. It is performed as follows:—*To tin copper or brass:* Boil 6 lbs. of cream of tartar, 4 gallons of water, and 8 lbs. of grain tin. Put in the articles to be tinned, and continue boiling until they are sufficiently covered. *To tin iron:* First make it bright, then soak it in an acid, such as sour whey, sour grains, or something similar; rub it over with sal ammoniac, and dip it in melted tin. Saucepans, &c. of copper are first well cleaned; then melted tin and sal ammoniac are put into them; then

put on the fire, and when the tin is melted they are turned about until it adheres.

TIN, Butter of. The perchloride of tin.

TINCAL. Crude borax.

TINCTORIAL MATTER. The same as coloring matters, or the colors given out by various animal and vegetable matters, when soaked or boiled in a liquid.

TINCTURE. Dilute alcohol, impregnated with the active principles of either vegetable or animal substances.

TINGE. A very faint tint or color.

TIN GLASS. Bismuth.

TINTS. Uniform, thin, delicate colors, laid on to a painting, mostly in an extended surface, so as to give it a uniform appearance. Also we speak not merely of the tints of a picture, but of any natural object equally colored, as the blue tint of the sky, the bright tints of autumn, &c.

TITANIC ACID. The peroxyde of titanium. It is called an acid merely because it unites with the alkalies.

TITANIUM, A rare metal, discovered by Klaproth, in 1794, in a mineral called menachanite. Also traces of this metal may be found in many varieties of iron. It is very brittle, so hard as to scratch steel, and of little specific gravity. It will not melt in the heat of any furnace, nor dissolve when crystallized even in nitro-muriatic acid, but only when in fine powder. It has not been applied to any use; calcined with nitre, it becomes oxygenated, forming a titanate of potass.

TOLU, Balsam of. This substance is obtained from the *toluifera balsamum*, a tree which grows in South America. It comes to Europe in small gourd shells. It is of a reddish brown color; of a fragrant odour, which it imparts to water by distillation, and to alcohol by solution.

TOMBAC, or WHITE COPPER. An alloy formed of variable proportions of copper, arsenic, and tin. Red tombac is made by fusing 5½ lbs. of copper, and then adding ½ lb. of zinc. It is more durable than copper.

TONE. In painting, a term employed to designate the prevailing hue or degree of harmony in coloring in a picture. Thus we say, this picture is of a dull tone, of a lively tone, of a clear tone, &c. Tone is not precisely synonymous with tint; the latter relating rather to the mixture of colors, and the former to their effect.

TONGUE. A projecting part at the edge of a board, to be inserted into a groove ploughed in the edge of another.

TONGUE. (See *Egg.*)

TOOLS. Implements used by artificers in the formation of the various articles they fashion or manufacture.

TOOTH OF A WHEEL, is a projection on the edge of it, either parallel, oblique, or

perpendicular to the axis, and by means of a series of which motion is communicated to the different parts of a machine. The teeth of wheels may be either external or internal, as in the following cut:—

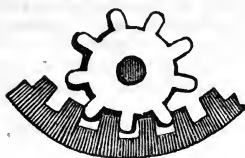

TOOTH ORNAMENT. A decoration peculiar to early English buildings. It has several varieties, some very ornamental. (See *Dog Tooth*.)

TOOTHED WHEEL. A wheel with teeth cut out around the circumference.

TOPAZ. A gem or precious stone of a yellowish, or sometimes of a rose red color.

TOPIARY WORK. A sort of garden ornamental work, which consists of giving all kinds of fanciful forms to arbours and thickets, trees and hedges.

TORNADO. A sudden and violent gust of wind arising from the shore, and afterwards veering round all the points of the compass. These are very frequent on the coast of Guinea.

TORRICELLIAN EXPERIMENT. A famous experiment, which ended in the discovery of the barometer, by which the philosopher Torricelli demonstrated the pressure of the atmosphere, in opposition to the doctrine of motion, which pressure he showed was able to support only a certain length of mercury or any other fluid in a tube.

TORRICELLIAN TUBE. The same as the barometer tube.

TORRICELLIAN VACUUM, is that made in the barometer tube, between the upper end and the top of the mercury. This is, perhaps, never a perfect and entire vacuum, though it is certainly the nearest to one that human ingenuity can devise. To procure it, take a tube of glass, 33 inches or more in length, and closed at one end; fill it with mercury, taking care that no bubbles of air remain in the tube; then putting the finger over the open end, carefully invert the tube into a basin of mercury. Upon removing the finger, the mercury will sink in the tube, according to the buoyancy of the atmosphere, until its upper end stands at a height of from 27 to 32 inches above the surface of mercury in the basin. The space void of mercury at the top of the tube will be the vacuum sought, and the method adopted to produce it is the Torricellian experiment.

TORRID ZONE, is the middle of the five zones into which the surface of the earth is supposed to be divided, and the hottest of

them; the sun being at all times of the year vertical over some part of it. It extends $23\frac{1}{2}^{\circ}$ on each side of the equator, or to the tropic of Cancer northward, and the tropic of Capricorn southward.

TORSION. A twisting like that of a rope or thread.

TORSION ELECTROMETER. (See *Coulomb*.)

TORSION, Force of. A term applied by Coulomb, in some of his experiments, to denote the effort made by a thread, which has been twisted, to untwist itself again.

TORTION GALVANOMETER. (See *Ritchie*.)

TORSO. The name given by artists to those mutilated statues, of which nothing remains but the trunk. The word torso is also applied to those columns, the shafts of which are twisted.

TORTOISESHELL. The plates which form the shell or covering of the *Testudo imbricata*. The number of plates which cover this animal are thirteen. They vary in thickness from $\frac{1}{8}$ to $\frac{1}{4}$ of an inch, according to the age and size of the animal, and weigh altogether from 5 to 25 lbs. Tortoiseshell is used for combs, boxes, and numerous ornamental trinkets.

TORUS. A round moulding, used in the base of columns, &c. It is the same as a bead, but larger and differently applied. In the cut A and B is each a torus.

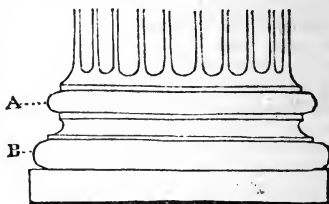

TOURBILLION. An ornamental fire-work, peculiar for turning round when in the air, so as to present the appearance of a scroll of fire. The cases are 7 or 8 diameters of them in length, made like rocket cases. The composition to fill them, and the manner of filling them, is also like that of rockets, except that 1 inch of clay is first rammed in; then the composition is to reach to within an inch of the top, and clay to fill up the remainder; when rammed, pinch up the end before left open. Balance each case on the finger, and at the centre of gravity, thus found, tie a cross stick, as represented; then bend the ends of the stick up a little, so that they shall be rather rounding, that the tourbillion may spin upon the centre of them. Then bore a hole near the clay, on each side of the case, and two holes underneath, and connect the holes with quick match. When to be fired, place them on a board, and set fire to the quick match, in

consequence of which fire will issue from four holes; that from the two lower holes will drive the tourbillion into the air, and that from the side holes will spin it round.

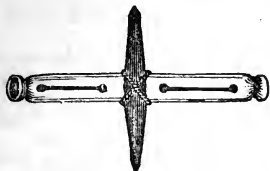

TOURMALINE. A mineral, of somewhat peculiar principle, particularly that when heated it shows, at different parts of it, electric poles; a fact which was known to the ancients, who called the stone *lyncurium*. It is also doubly refractive, for which and other reasons it is used in experiments on the polarization of light.

Tow. Coarse undressed hemp or old rope reduced to the state of filaments. This last is more generally called oakum, and is used to fill up the chinks and seams of ships.

TOWER. A lofty building, mostly round or polygonal; used to strengthen the angles of a fortress, to hold the bells of a church, as a place of observation, &c.

TRACERY. The ramified stone-work in the upper part of Gothic windows, connecting the mullions with the frame.

TRACING INSTRUMENT. This is very similar to the profile or silhouette instrument already described; (see *Silhouette*,) for which it may be substituted, even for the taking of likenesses. The chief difference is that the shorter end of the rod or tracer is curved, as shown in the figure; so that the point A may trace over the outlines of an object, which rests upon the frame work; at the same time B traces it of a larger size, on a sheet of paper at a distance, and *vice versa*.

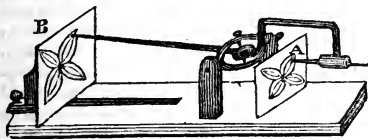

TRACING PAPER. (See *Paper*.)

TRACTION. The drawing of one body after another.

TRACTIVE POWER. The force necessary to drag any thing along a road or other surface, overcoming the friction occasioned by the transit.

TRADE WINDS. (See *Winds*.)

TRAGACANTH. A gum, also called gum adracant and gum dragon, is the produce of *Astragalus tragacantha*, and some other

shrubs. It is firm, rather heavy, tough, and difficult to powder, unless previously heated; of a pale, yellowish white color, sometimes brownish; has no smell, and but little taste; dissolves in water very slowly, and becomes mucilaginous. It is used chiefly by confectioners to make gum paste, to harden lozenges, &c.; also as a dressing or stiffening material to some textile fabrics.

TRAIL'S REGISTER THERMOMETER. This is a single spirit thermometer, in which a column of mercury, one-third of an inch in length, is introduced. At each end of this column lies an index of fine steel wire, gilt. The variations of bulk which take place in the spirit will move the column of mercury, and by this the indices are pushed in opposite directions, but will remain at the highest and lowest points to which they are driven by the mercury. The indices are brought back again into contact with the mercury by means of a magnet.

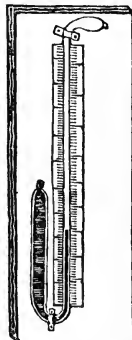

TRAJECTORY. A term generally used for the path of any body moving either in a void or in a medium, which resists its motion, or even for any curve passing through a given number of points. Thus astronomers speak of the trajectory of a comet, a planet, &c.

TRAM. The name given to coal waggons in the north; hence the words *tram road*.

TRAMMEL. In mechanics, an instrument used by artificers to describe ellipses. It consists of a cross, with two grooves at right angles to each other, and a beam, containing two pins that are made to traverse in the grooves by the revolution of the bar; the bar carries a pencil that describes the ellipse.

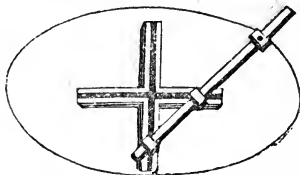

TRAM ROAD, or TRACK WAY. A roadway, consisting of narrow tracts, plates, or rails, of wood, stone, or iron, upon which waggons are made to pass backwards and forwards, for the conveyance of wood, coals from the pit, &c.

TRANSCENDENTAL, is a term applied to any equation, curve, or quantity, which cannot be represented or defined by an algebraical equation of terms, with numeral and

determinate indices. Transcendental quantities, therefore, include all exponential, logarithmic, and trigonometrical formulæ, by which these quantities can be expressed.

TRANSEPT. The tranverse division of those churches which are built in a cross form. The transept runs north and south; the nave and choir east and west.

TRANSFEROGRAPHY. An art invented by Mr. Williams for the copying of inscriptions, from ancient tombs, tablets, &c., which it does with the greatest accuracy. It is done as follows:—Provide a quantity of thin pliable paper (thin printing paper is the best.) A sheet of this is to be laid over the object to be copied, and fixed there steadily by paste, applied in two or three places at the corners or edges. Over this is laid a black tracing paper, made by rubbing paper over with lamp-black and soap, with a little water; the black side is of course to be laid inwards. Then rubbing the back of this second sheet of paper, with a smooth wooden knife, the pressure will transfer the black ground on to the first sheet of paper, wherever the surface of the inscription underneath is flat; but where there are any depressions, no transfer of the black will take place, consequently when done, the under sheet of paper will have in white every indentation of the stone beneath, while the general surface will be black.



TRANSFERER. An instrument used with the air pump, as a moveable portion or plate, for numerous purposes of experiment. There are single transferers and double transferers; the latter of which is shown annexed. It consists of two plates, ground truly flat, and having pipes beneath, communicating with each other by connecting tubes, and a large pipe and cock below, which fits on to the table of the air pump. If a glass receiver be placed over each transferer plate, they may be exhausted of air, and the lower cock being turned, they may be removed

from the air pump, and set aside, that the continued result of the experiment, whatever it may be, may be noted afterwards, and the air pump in the interim used for other purposes.

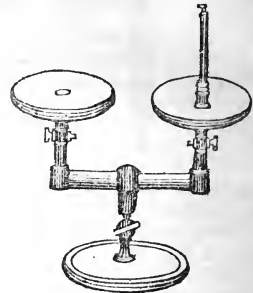

TRANSFERRING. The passing of one thing to another. The term is particularly applied to the printing of a design first upon paper, and afterwards placing that printed paper upon the article for which the design is intended; the paper being afterwards removed either by rubbing, burning, or other method, the design only remains, and looks as if it were originally printed upon the article. In this manner, plates, basins, and other crockery and china ware are printed. So also lithographic and other prints, may be transferred to wood, by first soaking the print in water, then varnishing the wood, sticking the print face downwards upon the varnish, while it is yet wet, and then carefully rubbing the paper from the back of the print. When as much as possible of this paper has been removed, and the whole is dry, a coat of varnish over it brings up the design, almost as clearly as in the original print. In lithography and copper or steel engraving, a transfer is the impressing a drawing, or writing upon a stone or metal plate. In lithography, a paper, called transfer paper, is previously prepared by washing a thin paper over with starch, and afterwards glazing it. This being drawn upon by lithographic ink is wetted, placed upon the stone to be used, and the whole covered over and passed through the press. The pressure here given to it transfers the ink from the paper to the stone, as if it were originally placed there. A transfer in the art of engraving is the drawing made on paper with chalk or black lead pencil. This being laid over the ground upon the plate, (see *Etching*,) and passed through the press, transfers the drawing to the ground of the plate, where it may be afterwards etched.

TRANSFORMATION. In geometry, is nearly the same as reduction, being used to denote the changing of any proposed figure to a different one of equal surface or solidity.

Transformation of Equations, in algebra, is a method of changing one equation to another form, but one of equal value.

TRANSIT. In astronomy, signifies the passage of any planet over a fixed star or the sun; and of the moon covering or moving over any planet.

TRANSIT INSTRUMENT. In astronomy, is a superior kind of mounted telescope or theodolite, for the purpose of noting accurately the transits of Mercury and Venus.

TRANSMISSION. Passage through a body, as of the rays of light through transparent objects, the transmission of the electric fluid through good conductors, &c.

TRANSMUTATION. In geometry. (See *Transformation*.)

TRANSOMS. The iron or stone bars which run horizontally across a window, dividing it into stories.

TRANSPARENCY. A transparent painting, made by painting on fine linen, thin paper, silk, &c., with transparent colors. It is illuminated by lights skilfully introduced behind, and produces a striking effect, either to illustrate scientific lectures, or on occasions of public rejoicings. Transparency, in painting, is when the painting is so executed as that the object appears light, lively, and as it were in reality transparent; such, for example, as water or the air. This effect is produced chiefly by the use of varnish, added to such colors as have not much body or opacity.

TRANSPARENT. Any thing which can be seen through.

TRANSPARENT COLORS. Certain colors are thus called to distinguish them from others which are opaque. Among the transparent colors are lake, verdigris, Indian yellow, gamboge, sap green, Prussian blue, burnt umber, sienna, &c. Among the opaque colors are vermilion, emerald green, Naples yellow, smalt, verditer, lamp-black, &c.

TRANSPARENT PAPER. (See *Paper Tracing*.)

TRANSPARENT SOAP. (See *Soap*.)

TRANSPOSITION. In algebra, is the bringing any term of an equation over to the other side of it, in which case the sign of the quantity thus transferred is changed; viz. from plus to minus, and from minus to plus. For example, if $a + x = b$, then transposing a , and changing its sign, we have $x - b = a$; and if on the other hand we have $x - a = b$, then by transposition we have $x = a + b$. This operation is performed in order to bring all the known terms to one side of an equation, and all those that are unknown to the other side, whereby the value of these last become determined.

TRANSVERSE. Across, or a section or measurement parallel to the ground, as the transverse section of a building shows the

various compartments of any floor looking down upon it from above. The transverse section of a tree is cut across the grain of the timber.

TRANSVERSE AXIS, or **DIAMETER**. In the conic sections, is the first or principal diameter passing through both the foci of the curve. In the ellipse, the transverse is the longest of all the diameters; in the hyperbola it is the shortest; and in the parabola it is like all the other diameters, infinite in length.

TRANSVERSE VAULTS. Those which run from windows, recesses, &c., into the main and central vault.

TRAPEZIUM. In geometry, a four-sided figure of which neither of the opposite sides are parallel.

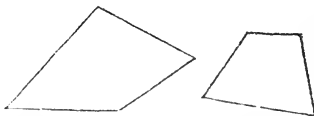

TRAPEZOID. A four-sided figure, of which two of the opposite sides are parallel, but not the other sides. Thus it is intermediate between a parallelogram and a trapezium.



TRAVERSE. In navigation, is the variation or alteration of a ship's course, occasioned by the shifting of the winds, currents, &c., or a traverse may be defined to be a compound course, consisting of several courses and distances; thus a ship much driven about is said to traverse, and the calculations necessary to reduce these traverses to one rectilinear course is called *traverse sailing*.

TREACLE. A thick brown liquid, which exudes from partially-refined sugar, it being that part which has not crystallized.

TREADLE. A lever attached to a crank, which communicates motion to machinery by the movement of the foot of the workman.

TREFOIL. A Gothic ornament, representing a clover leaf or three-leaved flower.



TRELICE WORK. Small bars of wood, nailed together obliquely, and crossing each other at regular intervals; used for summer houses, verandahs, &c.

TRENAIL. A wooden pin, employed in timber frame work in situations where iron

bolts are considered objectionable, as under water, in securing piles, ship's timbers, and the like. They are mostly used in fastening down the chairs of railways to the stone blocks beneath; holes being first drilled in the stone, then oaken trenails are driven in, and afterwards the iron pins which secure the chairs. The utility of the wooden trenail is to form a firm body around the iron pin.

TREPIDATION. A trembling. In the old system of astronomy by Ptolemy, it denotes a motion which was attributed to the firmament, in order to account for several changes and motions observed in the axis of the world, and for which he could not account upon any other principle.

TRESSEL. (See *Trussel*.)

TRET. In commerce, is an allowance made for waste, dust, &c., in various commodities, at the rate of 4 pounds to every 104 pounds purchased.

TREVITHICK'S STEAM ENGINE. This is the first application of steam to the motion of carriages, or the first locomotive engine, and is the joint invention of Messrs. Trevithick and Vivian. It is extremely compact and simple in its construction. Steam is admitted to the lower part of the cylinder R from the boiler; this raises the piston B. When it has reached the top, the communication between the boiler and the under-side of the piston is shut off, and the steam which has raised the piston escapes into the atmosphere. A passage is now, by means of a four-way cock, made for the steam above the piston, which drives it down, and the steam is again allowed to escape. From this it is obvious, that the engine acts upon the high pressure principle, and that its power will be equal to the difference between the pressure of the atmosphere and that of the

steam. H in the cut is a pipe which conveys the spent steam to the chimney. It is surrounded with a tube of hot water, to prevent its condensation before it arrives at the chimney, which would occasion it to run back as a liquid into the cylinder, and therefore soon fill it. X are guide rods, for the piston rod to work in. The connection between the piston rod and fly wheel is not shown.

TRI-. TRIS-. TRIT-. TRITO-. In chemical composition, has the same meaning as *ter*, indicating three proportions of the base to one of the solvent; thus, the tri-sulphate of copper contains three atoms of copper to one of acid.

TRIANGLE. In geometry, a figure bounded by three lines, and consequently containing three angles, whence its name. Triangles are of various kinds, as *plane* or *rectilinear*, or those that consist of straight lines, as A; *spherical*, or those which are bounded by three arcs or great circles of the sphere; or *curvilinear*, which are such as are bounded by any curved lines, as B.



Plane triangles are also distinguished by their shape, and the nature of their contained angles, as follows:—An *equilateral* triangle has its three sides equal, as C. An *isosceles* triangle is that in which only two sides are equal, as D. A *scalene* or *oblique* triangle is that which has its sides all unequal, as E.

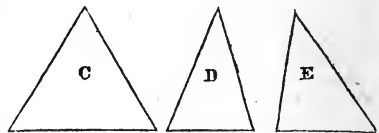

A *right-angled* triangle contains one right angle, as F. An *acute-angled* triangle has its three angles acute, as G; and an *obtuse-angled* triangle has one that is obtuse, as H.

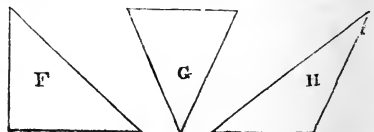

Spherical triangles are also divided into right angled, oblique, equilateral, isosceles,

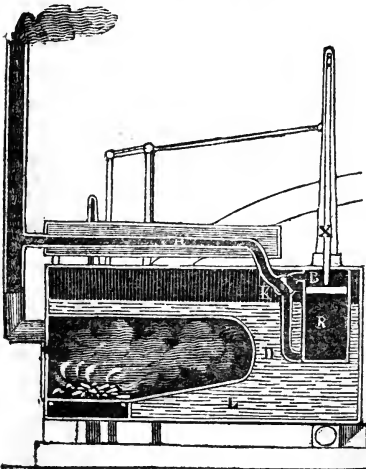

scalene, &c. They are also said to be *quadrantal*, when they have one side a quadrant. Also two sides or two angles are said to have the *same affection* when they are either both greater or both less than a quadrant or 90° ; and of *different affections*, when one is greater than a quadrant, and one less.

TRIANGLE, Isometrical, AND RULER. Contrivances of Mr. Pease, of Woolwich, for the more easy laying out of the lines of isometrical figures. The rulers may be 12 or 14 inches long, and about $1\frac{3}{8}$ broad. The triangle must be equilateral, and may be 4.92 inches each side. Both are made of box, about $\frac{1}{8}$ inch thick. They are graduated at their edges, and it is obvious that as all the angles in rectangular solids are by isometrical perspective either 60° , or the supplement thereof, (120° .) the above triangle requires only to be slid along the ruler, and lines drawn to follow its edges. The drawing is then complete. To graduate them, both must be marked in the ratio of 0.82 to 1, that is, a space of 0.82 inches on the triangle and ruler, will isometricaly represent 1 inch of the model to be delineated; or if the original object be measured by feet, yards, or any other magnitude, the same space will also represent one of either of these measures. Smaller parts are taken by the sub-divisions between these larger isometrical divisions. The following cross was drawn by aid of one of these simple, but very useful instruments:—

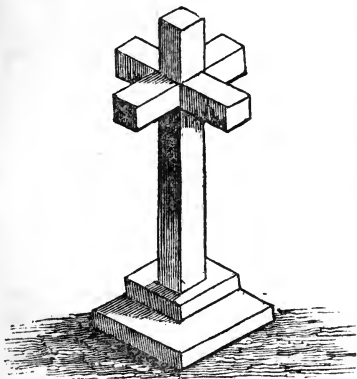

TRIANGULAR. Relating to a triangle.

TRIANGULAR COMPASSES. Such compasses as have three legs or feet, by which any triangle or three points may be taken off at once. (See *Compasses*.)

TRIGLYPH. An ornament of the Doric frieze, placed directly over each column, and at equal distances between. It has two entire triglyphs or triangular channels on gra-

in it, and the sides so cut away, that if two triglyphs were put together at their union would be a third channel

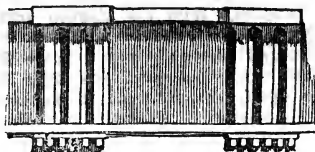

TRIGON. The same as triangle. In astronomy, the same as trine or aspect.

TRIGONOMETRY. The art of measuring the sides and angles of triangles, whether plane or spherical, hence called *plane trigonometry* and *spherical trigonometry*; or rather it is the determining certain parts which are unknown, from others that are known. It is used in almost every part of practical mathematics, navigation, and surveying, as very often by this science only can altitudes and distances be ascertained. It is founded upon the principle, that if one side of a triangle and two of its angles be known, the rest may be determined. Suppose we wish to ascertain the height of an inaccessible rock, which we cannot even approach near to, it is to be done by trigonometry, as follows, referring to the cut. Stand at any remote distance, as A,

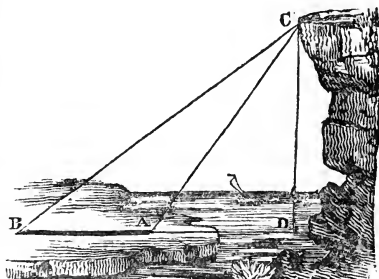

and by means of a quadrant or theodolite take the angle of altitude CAD . This subtracted from 180° will give the angle CAB . Then measure a straight line on the ground, the longer the better, AB , and at B take a second angle CBA . Then the base and adjacent angles being known, the side CA is easily determined by trigonometry. Then suppose the line BA produced to D , and DC drawn perpendicular to the base line, then we should have the angles at D and A known, and also the side AC , whence the perpendicular height and the base from A to D is easily determined. This added to AB gives the distance of the object from B , as well as the trigonometrical calculations the altitude of it. The trigonometry the extent of wood...

surfaces of water, and estates, which cannot be passed over, may be ascertained. It being only necessary to find the area of the triangle whose parts can be ascertained.

TRILATERAL. Any figure of three sides.

TRILLION. With the English arithmeticians it signifies a million billions, represented by 19 figures in a row; but with the French it is a thousand billions, their billion itself signifying a thousand millions, so that it is represented by 13 figures in a row.

TRIMMER. A small beam, receiving the ends of several joints, and to which they are trimmed or adjusted.

TRINE ASPECT. That situation of the planets and stars to each other in which they are at 120° angular distance.

TRINE DIMENSIONS. Three-fold dimensions, or length, breadth, and thickness.

TRINOMIAL. In algebra, any quantity of three dimensions, as $x^2 + xy + y^2$ or $a + b - c$.

TRIPARTITION. A division into three equal parts.

TRIPLE. Three-fold, or multiplied by three.

TRIPLE SALTS. Neutral salts, into the composition of which three substances enter. For example, common alum is a triple salt of alumina, potass, and sulphuric acid. Its proper name is, therefore, the sulphate of alumina and potass.

TRIPPLICATE RATIO. The ratio of the cubes of two quantities; thus the ratio of a^3 to b^3 is triplicate of the ratio of a to b .

TRIPOD. Any sort of vessel, table, seat, or instrument, having three feet.

TRIPOLI. An earthy mineral; used as a grinding and polishing substance. The most valuable comes from Corfu; a finer kind is found in Derbyshire and other places, where it is known as rotten stone. Unaccountable as it may appear, yet the strong powers of modern microscopes prove that all the tripoli of the world is composed of the exuvia or skeletons of insects, the species of some of which still exist, and are even common.

TRISECTION. The division of any thing into three equal parts. The trisection of an angle, by which any angle is indicated, is considered one of the impossibles of geometry, equal in difficulty to the quadrature of the circle, or the duplicature of the cube.

TRISPAST. A name given by the ancients to a combination of three pulleys.

TROCHILUS. The same as scotia.

TROCHLIA. The Latin name for a pulley.

TROCHOID. The same as cycloid.

TROPICS. In astronomy and geography, are two circles supposed to be drawn parallel to the equinoctial line, one on each side of it, at the distance of $23\frac{1}{2}^\circ$ nearly. That on the north is called the Tropic of Cancer, and that on the south the Tropic of Capricorn. On the terrestrial globe they bound the torrid

zone, and divide it from the north and south temperate zones.

TROUGH, Galvanic. (See *Cruikshank*.)

TROUGH, Pneumatic. (See *Pneumatic*.)

TROWEL POINT. An ornament in a wall, string course, &c., made with the point of a trowel, if in mortar; or of the same form, but larger, if in stone.



TRUCK. A wheeled carriage, moved by hand, or as applied to rail-roads, it is the name given to those low platforms upon wheels, which are used to contain stage-coaches and other vehicles carried along the line of a rail-way, the passengers mostly keeping their places.

TRUCKLES. Small wheels, for diminishing friction.

TRUMPET. The name of an instrument; used either for the purpose of being heard at a great distance, when spoken through, or of applying to the ear for increasing sound, and rendering it distinct; the former being called a *speaking trumpet*, the latter a *hearing trumpet*. Both of them act by reverberating the sound conveyed to them. If a speaking trumpet be attached to the mouth of a gun or cannon, the effect is astonishingly loud, and might be used as a signal at sea.

TRUNDLE, or WALLOWER. A wheel, which instead of being moved by teeth or cogs is furnished with round staves, upon which the teeth of another wheel take hold, and thus the trundle and wheel turn each other. That which is a pinion in iron work is usually a trundle in wooden machinery.

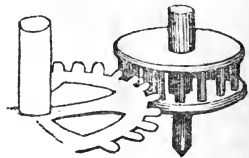

TRUNCATED. That quality of a solid by which a portion is cut off parallel to the base, or perpendicular to the axis, supposing there to be no base, as in crystals. In the following cut, one figure has truncated edges; the second, truncated angles; and the third, a truncated apex.

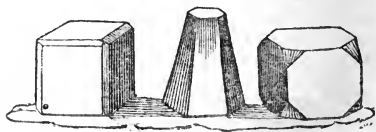

TRUNK. A vessel open at each end for the discharge of water, &c. Also the shaft of a column is sometimes so called.

TRUSS. Any method of uniting beams of timber, so that they shall touch each other only at certain points, and yet each mutually support the other; and all together unite equally in sustaining a weight laid upon the uppermost. (See *Roof*.)

TRUSSELS. Props for the support of any thing, the under surface of which is horizontal; each trussel consists of three or four legs, with a horizontal piece at top.

TRUSSING BEAM. The beam of steam engines, previous to the time of Watt, was composed of several beams of timber, of immense size, firmly bolted together. These, so cumbersome and expensive, were superseded by beams constructed of a single piece of timber, strengthened by slight trusses of iron work, similar to that represented in Watt's engine. (See *Watt*.) Iron beams are now almost universally adopted.

TRUSSING PIECES. Those timbers in a roof that are most pressed upon, consequently those which are the nearest to the perpendicular position.

TUBE. A hollow cylinder, such as the tube of the telescope, barometer, &c. In the arts, tubes, when of a large size and common materials, are usually called pipes. (See *Pipe*; also *Capillary Tube*.)

TUBE OF SAFETY. A tube open at both ends, inserted into a receiver, the upper end communicating with the external air; the lower being immersed in water. Its intention is to prevent injury from too sudden condensation or rarefaction taking place during an operation. For if a vacuum be produced within the vessel, the external air will enter through the tube, and if air be generated, the water will yield to the pressure from the confined gas or gases. It is now more frequently used of a curved form, like that represented in the margin, with or without a bulb in the upright stem; the lower end of this, instead of being immersed under the liquid in the receiver as the straight tube, is merely inserted into the tube. The requisite tightness and pressure is obtained by pouring a little mercury, or in some cases oil into the tube; this resting in the legs of the lower bend, keeps the vessel perfectly air-tight. (See *Welter* and *Woulfe*.)

TUFA. A soft sandy stone, of a calcareous nature, porous, soft, light, and ductile; formerly used in the construction of some edifices. It is said to be admirably adapted for the formation of vaults.

TUDOR FLOWER. An open crest or para-

pet formed of tre-foil leaves; much used in the time of the Tudors.



TUDOR ROSE. An ornament common to the same period.



TULA METAL. An alloy of silver, copper, and lead.

TUMBLING BOB. A name given to a loaded lever or counterpoise weight, often attached to machinery to produce a backward or contrary motion to that occasioned by the machinery itself; for example, suppose in the following cut, that C is connected with a valve or cock, and that A D is a lever attached to C, and turning on a centre at the lower end of B. When the end A is pushed down by the plug frame, it will open the valve and lift up the tumbling bob D; when the plug frame rises, it may not lift up the end A, yet the tumbling bob will, by its weight, move the lever C contrariwise, and thereby close the valve.

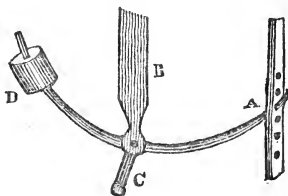

TUNBRIDGE WARE. Boxes, tea-chests, dressing cases, trays, writing desks, and numerous light and elegant works of the like kind, made of ornamental woods, and highly wrought and polished, the produce of various manufactories in Tunbridge; hence all work of a similar kind is called Tunbridge ware.

TUNGSTATES. Salts of the tungstic acid.

TUNGSTEN. A white, ponderous mineral, found in Sweden, composed of lime and a

peculiar earthy substance, which from its properties is called tungstic acid. The basis of this acid was found to contain a metal which has been named tunsten, and which was obtained from the acid by calcining the acid along with charcoal powder.

TUNNEL. A subterranean gallery or passage, excavated or dug through the earth for the passage of a canal, road, or railway.

TURBETH MINERAL. The yellow subdeuto-sulphate of mercury.

TURKEY RED. A brilliant red color, produced by madder upon cotton goods.

TURKEY STONE. A species of slate, used as a whetstone for the sharpening of tools.

TURMERIC, or INDIAN SAFFRON. A root brought from the East Indies, and employed in making a yellow dye. The coloring matter it yields is abundant and brilliant, but not durable. By chemists papers stained with turmeric, or a solution of the coloring matter is used as a test for alkalies, which turn the yellow into a brown color. By housewives, pastry cooks, &c., it is used for giving a yellow tinge to cakes and similar articles.

TURNING. The art of carving or working metals, ivory, wood, and other materials, so as to give to them a circular, or in some instances an oval form, using at the same time an instrument, called a lathe, (see *Lathe*,) one part of which gives the material a rotatory motion, while another part holds it tight, and a third part, equally necessary, secures the steadiness of the tool. (See *Lathe, Rest, Chuck, Slide Rest, &c.*)

TURN-CAP. A chimney top, which turns round with the wind.

TURN BRIDGE. (See *Swing Bridge*.)

TURN PLATE, or TURN TABLE. A contrivance for removing railway carriages from one line of rails to another. They are generally made for crossings at right angles with each other, but can be adapted to any angle that may be required.

TURNSOLE. (See *Archil*.)

TURPENTINE. A transparent resinous juice, flowing either naturally or artificially from incisions cut in the bark of numerous trees of the pine and fir species. The essential oil distilled from this resin is called spirit or oil of turpentine, or *turps*. There are various kinds of turpentine, as follows:—*Venice turpentine*, procured from the larch tree, (*Pinus larix*.) *Common turpentine*, procured from the Scotch and the spruce fir, (*Pinus abies* and *Pinus sylvestris*.) *French turpentine* from the *Pinus maritimus*. *Strasbourg turpentine* extracted from the *Pinus picea* and *Abies excelsa*. *Chio turpentine* from the *Pistacia terebinthus*; the tree which produces the *Pistacia* nut; and, lastly, *Canada balsam*, which is a turpentine extracted from the *Pinus canadensis* and *balsamea*. This kind is very pure and transparent.

TURNPIKE STAIRCASE. A winding stair, where the stairs are all made around a central newel or post.

TURQUOISE. An ornamental stone of a bright blue color, found only in Persia, where it is much esteemed. Bone turquoise is phosphate of lime, colored with oxyde of copper.

TURRELL'S PERSPECTOGRAPH. (See *Perspectograph*.)

TURRET. A small, slender, tall tower.

TUSCAN ORDER. A Roman order of architecture, with the general simplicity and character of the Grecian Doric; divested however of the flutes of the columns and the peculiar ornaments of the entablature. It is plainer and less exact in its proportions than any other order, and used only for inferior buildings or parts of buildings, such as porches, &c. The following cut shows the Doric entablature, capital, and base to the column:—

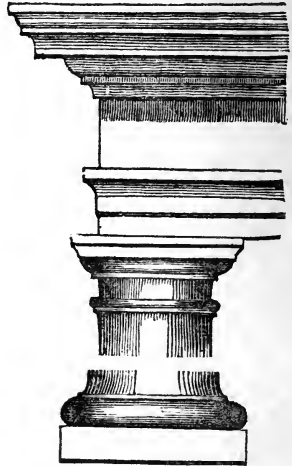

TUTANIA, or BRITANNIA METAL. An alloy, for the composition of which the following receipts are given:—To 4 ounces each of brass and of tin, add when in fusion 4 ounces each of bismuth and of antimony. This is the composition or hardening that is to be added at discretion to melted tin, until it has acquired the requisite degree of hardness and color; or else 1 lb. of copper, 1 lb. of tin, and 2 lb. regulus of antimony, with or without a little bismuth. For the German tutania take 2 drachms of copper, 1 ounce regulus of antimony, and 12 ounces of tin. For the Spanish tutania, melt together 4 oz. of antimony, 1 oz. of arsenic, and 2 lbs. of tin.

TUTENAG. A name given in India to metallic zinc. The Chinese copper is also called by this name, which is alloyed with zinc and

forms a very hard white metal, but little disposed to tarnish.

TUTTY. An old name for impure protoxyde of zinc.

TUYERE, TUE-IRON, or TEW-IRON. An orifice through which a blast or strong current of air is passed into forges.

TWILIGHT, is that faint light which is perceived before the rising of the sun, and after his setting, or when he is in either instance less than 18° below the horizon. The twilight is occasioned by the earth's atmosphere refracting the rays of the sun, and reflecting them among its particles.

TWINKLING OF THE STARS, denotes that tremulous motion which is observed in the light proceeding from the fixed stars; a phenomenon which is said to arise from the unequal refraction of light, in consequence of inequalities and undulations in the atmosphere.

TYCHOEAN SYSTEM. A system of astronomy, taught by Tycho Brahe, to account for the motions of the bodies belonging to the solar system. He imagined the earth to be in the centre of all; that the moon revolved around the earth nearest to her, next the sun, at a still greater distance, the planets Mars, Jupiter, and Saturn, but that the inferior planets, Mercury and Venus, revolve not around the earth, but around the sun, like satellites to him, and were consequently carried round the sun's supposed orbit with him.

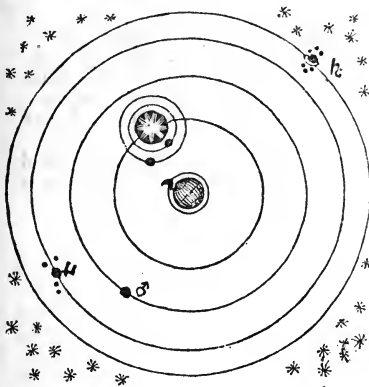

TYMPAN. That part of the printing press on which the paper is laid, when about to receive the impression. It is a double frame, one half of which folds upon the other.

TYMPANUM, is a hollow wheel, wherein one or more persons or animals walk to turn it, such as that of some cranes, treadmills, &c.

TYMPANUM. The flat triangular part of a pediment, corresponding to gable. It is often richly sculptured.

TYPE. In general terms, is an emblem, or example of any thing more valuable, or more conspicuous; thus we say that a medal is a type of a certain victory; a certain sentiment is the type of a man's mind, &c. In the art of printing, types signify the different pieces of metal which represent the various letters, stops, figures, &c. These types are of various sizes, each known by a particular name. Those used chiefly for book-work are as follows:—The numbers attached to each show the number of lines in a page of 6 inches long, and also the number of *ens* which would fill a measure of $3\frac{1}{2}$ inches wide.

English	32	47
Pica	$35\frac{3}{4}$	49
Small Pica ...	$41\frac{1}{2}$	55
Long Primer ..	$45\frac{1}{2}$	62
Bourgeois	$51\frac{1}{8}$	68
Brevier	$56\frac{1}{4}$	72
Minion	64	75
Nonpareil	$71\frac{1}{2}$	87
Pearl	89	103
Diamond.....	$102\frac{1}{2}$	128

The above is not always exactly correct, because founders differ in a slight degree in the size of their letters, though called by the same name. Types larger than the above sizes are used for posting bills, and are called by the names of *2-line pica*, 3, 4, 6, 8-*line pica*, and so on, and are often of wood. Types are also distinguished by their shape and the character of their ornament; hence arise the terms *Roman*, *italic*, *script*, *black letter*, *ronde* or *engrossing*, *flowered*, *Tuscan*, *phantom*, *Egyptian*, and *sans serif*; besides types that are cast for different foreign languages, symbolical characters, &c. A *fount* of type is a collection of all letters and characters necessary in printing a work of a particular sized letter; these letters being in the average proportion in which they are likely to be required. Types of a particular fount are variously called, as capitals, small capitals, lower case or small letters, stops and accents, figures, quadrats, and spaces; both which last signify the blank squares placed between the words to divide them from each other; the larger blanks being called *en*, *em*, 2, 3, or 4-*em quadrats*, and the others *thick*, *middle*, *thin*, and *hair spaces*, according to the size of each respectively.

TYPE FOUNDED. The art of casting printers' type. The process may be briefly described as follows:—A well tempered steel punch is first prepared. The founder stamps this upon a piece of brass or copper, to be used as a matrix or mould. The sides of the mould separate into two parts, and are of steel, cased with wood. The type metal is poured into a hopper-like top. The matrix being placed in the bottom of the mould,

the type metal is poured in by a small ladle. The workman then jerks the mould upwards, which at the same time drives out the air, and cools the metal; he then uncloses the mould, takes out the cast letter, closes the mould again, ready for another operation, all in the space of $\frac{1}{2}$ of a minute of time. From the table of the caster, the types are taken to another table by a boy, whose business is to break off the superfluous metal. They are then rubbed on their sides on a grit-stone; to make them perfectly flat and square. They are then arranged in a frame, and tied up in packets ready for sale. The rubber will

smooth 2000 types in an hour; and breaking off the superfluous metal is yet more expeditiously performed; and yet so true that all the types are exactly of the same height, and their sides perfectly symmetrical and uniform, otherwise they would be quite useless.

TYPE METAL. For the casting of ordinary large type, the founders use an alloy of 3 parts lead and 1 of antimony. Though the composition varies from $\frac{1}{2}$ to $\frac{1}{8}$ of antimony. For smaller type may be used, 9 lbs. lead, 2 lbs. antimony, and 1 lb. bismuth. This last alloy expands in cooling.



The fifth vowel. It has two sounds; one clear, expressed at other times by *eu*, as in obtuse; and the other close and approaching to the sound of double *o*, as in obtund. Its form is quite of modern date, having been originally identical with *V*. (See *V*.) It is, therefore, not seen in inscriptions nor on ancient coins. We, however, at present use the following contractions:—*U*, united as *U.S.*, United States; *urb.*, urbanus; *ult.*, ultimo; *ur.*, uranium, &c.

ULLAGE OF A CASK. In gauging, is what it wants of being full.

ULMIN. A vegetable principle, supposed to be distinct and confined to the *Ulmus niger* or *black elm*, from the trunk of which it is said to have exuded. In appearance and character it is something like a coarse brown gum.

ULTIMATE PRINCIPLES. Those simple bodies into which a compound may be separated. Thus to say, that the chloride of soda or common salt consists of hydrochloric acid and soda is separating it only into its proximate elements, and not its ultimate, which are oxygen, hydrogen, and chlorine, in the acid, and oxygen and sodium in the alkali. The principal ultimate elements of all organic bodies are oxygen, hydrogen, and carbon, to which animal substances add nitrogen, together with other principles, peculiar to certain of them.

ULTRAMARINE. A beautiful blue color, used by painters, and prepared by calcination from *Lapis lazuli*. The genuineness of this article may be proved by putting a portion into an iron ladle, and if when the ladle becomes red hot, the paint retains its color, it is unexceptionable. This exquisite color has the virtue of being extremely lasting, perhaps more so than any other blue ever produced.

ULTRAMUNDANE. Beyond the world, or that part of the universe which is supposed

to be beyond the limits of our system, or that planetary system of which the earth forms a part.

UMBER, or UMBRE. A brown iron earth, used both as an oil and water color; of a fine and durable tint, the beauty of which is much increased by calcining it; then called *burnt umber*. It came originally from *Ombria*, in Italy; but is now chiefly brought from *Cyprus*. An inferior kind, called *English umber*, is found in *Derbyshire*, *Somersetshire*, and other parts of *England*; also in *Wales* and *Ireland*.

UMBRA. A shadow, particularly the shadow cast by one heavenly body upon another, as during the time of an eclipse.

UNCIAL. A term applied to letters which stand for words in inscriptions and epitaphs, titles, &c.; as *A.M.*, Master of Arts; *D.D.*, Doctor of Divinity. Our initial letters give the chief of these abbreviations, used both among the ancients and moderns.

UNIFORMITY. Resemblance of shape, of aim, or of style, between the several parts of a whole.

UNDECAGON. A figure of eleven sides.

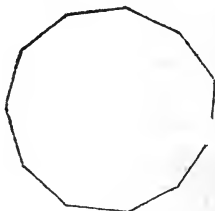

UNDERCROFT. A subterranean apartment or crypt.

UNDERSSETTING. The supporting a wall or edifice, or an overhanging projection of rock, &c., after the lower part has been removed, or an excavation made beneath. Thus the *Custom House*, *London*, was underset some years ago, a new foundation having been

made to it without the superstructure being disturbed. The following shows an under-setting of a chalk cliff:—

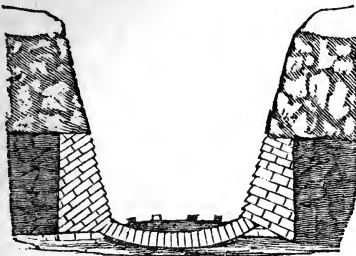

UNDERSHOT WHEEL, is one which is turned by a stream of water flowing against its lower side.

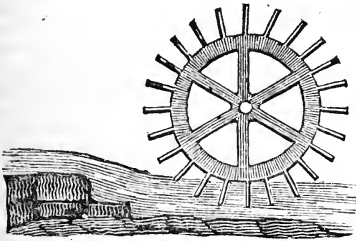

UNDULATORY MOTION, is applied to denote a motion in any fluid, by which its parts are agitated like the waves of the sea, and is particularly applied to the motion of the air in the propagation of sound.

UNEVEN NUMBER. That which cannot be divided into two equal parts.

UNGULA. In geometry, is the bottom part cut off by a plane passing obliquely through the base of a cone or cylinder, being thus called from its resemblance to the unguia or hoof of a horse.

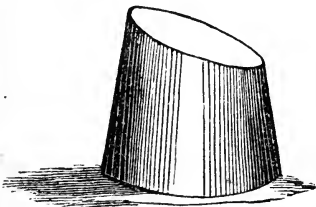

UNCIA. The twelfth part of any thing.

UNICIÆ. The same as co-efficients.

UNIT, or UNITY. The representation of any thing considered individually, without regard to the parts of which it is composed.

UNIVERSAL CHUCK. The name given to the following chuck:—The screw which attaches it to the mandril is not shown. It is

supposed to be at A, beneath which, and on the face of the chuck is a hole; in this is to be inserted the substance to be turned. B B is a screw placed transversely, which is prevented moving endwise by a collar in the middle of it. One end of the screw is cut right-handed, and the other end left-handed, so that by turning it one way the nuts D and C recede from each other, or by turning it the contrary way they advance towards each other. These two nuts pass through grooved openings in the plate E, and project beyond it, carrying jaws like those of a vice, by means of which the substance to be turned is held.

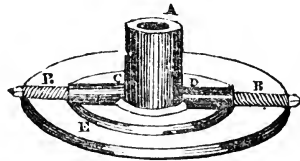

UNIVERSAL DISCHARGER. (See *Henley*.)

UNIVERSAL JOINT. (See *Hooke*.)

UNIVERSE. The whole of created nature, including our solar system, and all the starry regions beyond.

UNLIKE QUANTITIES. In algebra, are such as are expressed by different letters, or different roots or powers of the same letter.

UNLIMITED PROBLEM. That which admits of an indefinite number of solutions.

UPHERS. Fir poles, fit for scaffolding, or the making of ladders.

URANIC ACID. Peroxyde of uranium, or the sesquioxide of uranium.

URANIUM. A rare metal, discovered first by Klaproth, in the black mineral, called pech-blende.

URANUS, HERSCHEL, or GEORGIUM SIVUS. The last or most distant planet of the solar system, discovered by Dr. Herschel, in 1783. It is 1800 millions of miles from the sun, and performs its revolution around him in 83 years, 150 days, and 18 hours. Its diameter is about four times larger than that of the earth, being nearly 35,112 English miles. Uranus is attended by six satellites.

URE'S CHLOROMETER. (See *Chlorometer*.)

URE'S EUDIOMETER. (See *Eudiometer*.)

URN. A low wide vase, distinguished according to its applied use, as a funeral urn, a fountain urn, &c.

UREA. A substance which forms part of urine. This and uric acid, which is urea united with oxygen, contains proportionably more nitrogen than any other animal substance.

UROBENZOIC ACID. An acid thrown down from the urine of horses and cows, by mixing with it hydrochloric acid.

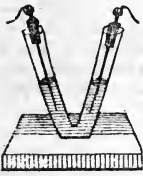

This letter in ancient times was synonymous with U, and considered to express that letter when used as a consonant; the same character representing both. V is now considered a distinct letter, and which has a sound intermediate between B and

F. In ancient inscriptions it is very frequent, and in Roman notation signifies the number 5.

V TUBE. A glass tube, in the form of the letter V (*see the preceding cut.*) to show the decomposition of a neutral salt by galvanism. It is a common glass tube, with a cork at each end, and a platinum wire through each cork. The solution of a neutral salt, colored by litmus, is poured into the tube; a galvanic current being made to pass from wire to wire, through the liquid, decomposes it, drawing the alkali to one pole, and the acid to the other, as is made visible by the changes of color produced in the different ends of the solution; it being reddened on one side, and rendered green at the other.

VACUUM, is literally an empty space; but is generally used to denote the interior of a close vessel, from which the atmospheric air and every other gas has been extracted. (*See Torricellian.*) The vacuum produced by means of the air pump is always imperfect; the vessel is nevertheless termed an exhausted receiver.

VALLEY. Any extended recess between two prominences. In building it is the internal angle or gutter between two inclined sides of a roof; the timbers used in such places are called *valley rafters, valley boards, valley pieces, &c.*

VALONIA. A kind of acorn, imported from the Levant and the Morea, for the use of tanners, as the husk or cup contains abundance of tannin.

VALVE. A moveable cover to an aperture, occurring in various hydrostatic and pneumatic engines. Valves are sometimes moved by a contrivance independent of the medium in which they act; at other times by the power of the heavier medium, they being placed between two, as for example, water and air. Valves are constructed of a variety of forms, but they may be described generally as of four kinds. First, those of the revolving description, comprising all cocks from that in common use to the four-way cock of the steam engine. Secondly, those which are lifted by a power beneath, such as the conical valve, the ball valve, cup valve, and safety valve. Thirdly, those which are hinged, such as the clack valve and the butterfly valve. Fourthly, such as slide backwards and forwards, as the air valve, the gas regulating valve, the D valve, and the sliding valve of the steam engine; all but the last

have been already described, and will be found under their respective names. And, fifthly, such valves as are kept to their places by a spring, and are moved by human touch; or this kind are the valves or keys of the flute or organ, the valve of the water closet, &c.

VALVED. Any thing that opens upon hinges or to which a valve of any kind is attached.

VANADIUM. A rare metal, discovered in Swedish iron in 1830. It is also found in a lead ore from Mexico; in both cases combined with oxygen into the state of an acid, called the vanadic acid. It also combines with oxygen in two other proportions, forming oxydes. The metal is white, like silver. The vanadate of ammonia, mixed with a solution of nut galls, is the best writing ink known.

VANCOUVER'S CEMENT. The white of egg, dried, pounded, and mixed with a sixth part of quicklime, in powder; when afterwards wetted, it becomes a very tenacious cement, not injured by water or heat.

VANE. A flat surface, capable of being moved by the current of a fluid; as for instance, the vanes of a windmill, the vane which surmounts a weather cock, &c. Vane is also synonymous with fly or fly wheel. The sights which slide backwards and forwards upon levels, cross staffs, &c., are also called vanes.

VANE, Electrical. A wheel, made of card board, and balanced upon the point of a pin or other wire. When a stream of the electricity from a common electrical machine is allowed to issue from a blunt point, and the vane is placed near to it, the strength of the current will be sufficient to impel the vane forward, so that it will rotate on its centre. It may be made to turn either vertically or horizontally, and of many forms. The following is one which will generally succeed, as the friction upon a point is very little:—

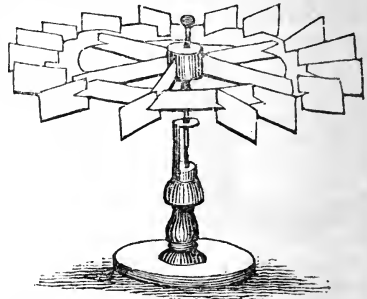

VANISHING FRACTIONS, are fractions in which, by giving a certain value to the variable quantity or quantities which enter into them, both numerator and denominator become zero, and the fraction itself $\frac{0}{0}$. For

example, if $a=2$, and $x=4$, then the fraction $\frac{a^2}{x}$ will be a vanishing one, or of no value.

VANISHING LINE. (See *Perspective*.)

VAPOUR. A watery emanation, uprising either from the earth or from the surface of aqueous bodies. If the latter, and assisted by heat, it is commonly called *steam*; if arising from a gradual evaporation from the earth, such are called terrestrial vapours, and fill the atmosphere, descending afterwards as dew, rain, or other falling liquid. These while buoyant in the air produce various phenomena of unequal refraction, reflection, clouds, &c.

VARIABLE QUANTITIES, are such as are continually decreasing or increasing, in opposition to those which are constant.

VARIATION OF CURVATURE. The change made on a curve, so as to occasion it to be flatter or sharper in each succeeding part. For example, spirals are flatter as they proceed from a centre.

VARIATION OF THE MAGNETIC NEEDLE. (See *Magnetic Declination*.)

VARIATION OF THE MOON. (See *Libration*.)

VARLEY'S GRAPHIC MICROSCOPE, &c. (See *Graphic*.)

VARNISH. A clear limpid fluid, capable of hardening without losing its transparency; used by painters, gilders, cabinet makers, &c., to give a lustre to their work, to preserve them, and defend them from the air. The properties of good varnish are that it shall become quite hard, not crack, become discolored, nor lose its lustre by time, lay upon the work in an even coat, not be affected by water or a damp atmosphere, and not alter the colors over which it is applied. The base of all varnishes are the various resins, which are soluble in fixed oil; volatile oil, of which spirits of turpentine is the most used; and alcohol. The spirit of turpentine is mostly added to the oil varnishes to produce sufficient fluidity. The spirit or alcoholic varnishes are the following:—*White spirit* varnish, (see *Sandarac*;) *cabinet-maker's* varnish, made of pale shell lac, 750 parts; mastic, 64 parts; alcohol, 1000 parts by measure. It is made cold, and is easily injured by heat and spirituous liquors spilt on it. *Golden* varnish: Gum lac in grains, 25 parts; gamboge, 25; dragon's blood, 25; annatto, 25; saffron, 6 parts. Strong alcohol to be added till sufficiently thin. *Mastic* or *picture* varnish, (see *Mastic*.) *Crystal* varnish is made of Canada balsam and spirits of turpentine mixed together when both are warm. *White hard* varnish: Agitate together in a large tin bottle, 2½ lbs. of gum sandarac and 1 gallon of spirits of wine, when dissolved it will be fit for use. *Brown hard* varnish: Agitate together till dissolved 1½ lb. sandarac, 1 lb. shell lac. and 1 gallon alcohol. Oil var-

nishes:—*Turpentine* varnish is made with common rosin, boiled in linseed oil and diluted with spirits of turpentine. For *copal* varnish, (see *Copal*.) For *amber* varnish: Take 8 ozs. of amber, coarsely powdered, 1 oz. of Venice turpentine, 5 ozs. of linseed oil, and 8 ounces of spirits of turpentine; boil the amber in the oil, and then add the turps. For a black varnish, (see *Brunswick black*.) For a varnish for tin and brass ware, (see *Lacker*.) For balloon varnish, (see *Caoutchouc*.)

VARNISH. Among medallists, is the term used to signify those hues which antique medals have acquired by laying in the earth.

VARNISH LENSES. Small lenses made by putting a drop of transparent copal varnish on to a flat piece of oiled glass. It congeals into a plano-convex lens, of considerable magnifying power.

VASE. A large ornamental cup or pitcher; used either to contain liquids, flowers, or other articles, for use or decoration, or as a termination to columns, pedestals, and the like, either in gardens, galleries of art, court yards, on walls, &c.

VASES, Magic. (See *Magic*.)

VAULT. A subterranean room, arched over with masonry. Also a bricked grave. Vaults have different names, according to their shape and style of decoration, as plane, ribbed, groined, cylindrical, conic, spherical, annular, and simple or compound.

VAULT, Reins of. The sides or walls which sustain the arch.

VAULTED. Any part of a building, covered with arched stone or brick work; as we say, vaulted aisles, vaulted corridors, vaulted roof, and so on.

VEGETATION OF SALTS. A curious phenomena, which takes place when strong solutions of metallic salts are left in glass, earthenware, or other vessels, by which they appear to grow up the sides of the vessels, and above the surface of the solution, presenting a beautiful cauliflower-like appearance. This may be easily seen in a solution of the sulphate of iron, copper, or zinc, when left undisturbed for some days in the light, for it is a remarkable fact, that the effect does not, according to M, Chaptal, take place in the dark. The annexed cut may convey a faint idea of the experiment, observing that to produce so conspicuous an effect, a wine glass should be filled to within half-an-inch of the top with the solution.



VEGETO-ALKALIS. The alkalis potass and soda, which are extracted from the ashes of vegetables; the term being used to distinguish

them from ammonia, which is an animal product; and from the alkaline earths, which are minerals.

VEGETO-ALKALOIDS. (See *Alkaloids*.)

VEHICLE. A support or conveyance. Thus we speak of a waggon, being a vehicle of conveyance for goods; and no less correctly that an oil is a vehicle for color for the painter; a book a vehicle of information; or a particular menstruum a vehicle for the solution of a salt or a gum; though these latter and other applications of the word have evident reference to its first import.

VEINS. Fissures or rents in rocks, which are filled with peculiar mineral substances, most commonly metallic ores. The earthy parts found with such ores are called *gangues* or vein stones.

VALERIANIC ACID. An acid product, extracted from common valerian.

VELLUM. Prepared calf's-skin or amb-skin, which being finer in texture, and smoother than parchment, is often used to write and print upon, as well as in drawing and painting.

VELOCITY. The measure of swiftness with which a body moves.

VELOCIPEDE. An instrument of locomotion, moved by the impulse given to it by the rider's feet against the ground. The front wheel is moveable horizontally, to enable the rider to guide the machine.



VELOCITY, Principle of Virtual. An important principle in mechanical science, indeed the foundation of all principle, as it proves the power of every machine is only an application of the force which is applied to it, and that no machine can multiply power, for where it gains in impulse it loses in time; so on the contrary, if the velocity of any thing is increased, it has received a proportionately-increased impulse. In every case, therefore, we may say that the power multiplied by its velocity is the same as the weight multiplied by its velocity; thus if a ball of 1 lb. weight, moving 3 feet per second, strike a ball of 6 lb. weight, it would drive it forward with a velocity equal to $\frac{3}{6}$, because $3 \times 1 = 6 \times \frac{3}{6}$. So again, a power multiplied by the distance it moves in, is always equal to the weight multiplied by its distance. If a pump throw up 30 gallons

of water per minute, at a power equal to 40 lbs., and it be made to throw up 90 gallons, you must increase the power to 120, either working three strokes in the time of one before, by making those strokes three times as long, or else increase the size of the pump barrel, and apply three men instead of one. Nothing is ever made, no power is ever created by machinery. This is the principle of virtual velocities, and is applicable to thousands of applications, observing always that *friction* must be allowed for, as it much influences the practical result, though it does not interfere with the grand theory or principle.

VELVET. A silken or cotton fabric, made so as to have a short nap or pile similar to that upon woollen cloths.

VENER. A very thin leaf of wood of a superior quality, for covering articles of furniture or ornament which are made of an inferior wood.

VENETIAN CHALK. Steatite or soap stone.

VENETIAN DOOR. A door lighted by panes of glass on each side.

VENETIAN WINDOW. A window in three separate apertures, the two side ones being narrow, and separated from the centre by timber only.

VENT. The tube of a chimney for conveying the smoke from the fire. In London it is called *flue*, and in some parts of England *funnel*.

VENTILATION. The renewal of fresh air in places where without ventilation it would be stagnant.

VENTILATOR. A small machine made to turn with the wind, and placed in a wall, roof, or window, in order to let out heated and impure air, and admit a supply of fresh.

VENUS. The second planet of our system in order from the sun, revolving between the orbits of Mercury and the earth, at a mean distance from the sun of 68 millions of miles. She performs her sidereal revolution in 224 d., 16 h., 49', 11"; her rotation on the axis is in 23 h., 21', 7", 2"; and the diameter 7702 miles, or nearly that of the earth. She is also surrounded by an atmosphere, the refractive powers of which differ but little from those of ours. As viewed from the earth, Venus is the brightest and largest planet, being often visible at noon-day, and frequently noted as a brilliant morning or evening star. Venus changes her phases like those of the moon, according to her position, relative to the earth and sun.

VERA'S ROPE PUMP. (See *Rope Pump*.)

VERATRINE. A poisonous, vegetable alkaloid, extracted from the seeds of the *veratrum sabadilla*; the roots of *veratrum album*, or white hellebore; and of *colchicum autumnale*, or meadow saffron; in which plants it exists, combined with gallic acid. It is obtained in the state of a white powder.

VERD ANTIQUE. A beautiful green marble.

VERDIGRIS. The acetate of copper. It is a color much used in painting. Venetian blinds are painted with common varnish mixed with verdigris and white lead. It is a favorite pigment with the artistical painter for garden scenery. It serves also (mixed with cream of tartar or vinegar) to make a kind of water-green for coloring maps.

VERDIGRIS, Distilled. A bin-acetate of copper, made by dissolving in a copper kettle, 1 part of verdigris in 2 of distilled vinegar, aiding the solution by slight heat, and occasional agitation with a wooden spatula.

VERDIC ACID AND VERDOUS ACID. Two acid principles extracted from various plants of the umbellate kind, and from some of the scabiosas. It is of no known use.

VERDITER, or BLUE VERDITER. This is a precipitate of oxide of copper with lime; made by adding that earth in its purest state to a solution of nitrate of copper. The precipitate, when nearly dry, is triturated with lime.

VERJUICE. A harsh, austere vinegar, made of the expressed juice of vine leaves, tendrils, unripe grapes, crab apples, and other unripe fruits.

VERMICELLI. A paste of wheat-flour drawn out and dried in slender cylinders, more or less tortuous, like worms; hence the Italian name.

VERMILLION. An extremely bright and beautiful red color, composed of quicksilver and sulphur, in great esteem as a body color, and held equally in esteem by the ancients, under the name of *minium*; (the minium of modern times is red lead.) There are two kinds known in our market; that prepared in England, and called English vermilion; and the Chinese vermilion, which last is more finely ground, and of a more brilliant color.

VERNIER. A contrivance connected with a graduated scale, and employed for measuring any portions of the space between its most minute divisions. Verniers are applied to astronomical and surveying instruments, quadrants, &c.; for example, let A G be any portion of the limb or scale of a quadrant, that is, half a degree divided into 6 parts, A B, B C, &c., of 5 minutes each.

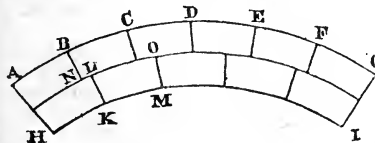

Let H I be another limb of equal extent divided into 5 parts. In consequence of the

relation of these divisions, we see that the line K L will be further advanced than N by a fifth part. The next line M O, in the lower scale, by $\frac{2}{5}$; the next by $\frac{3}{5}$; the one afterwards by $\frac{4}{5}$; and the last by $\frac{5}{5}$, or a whole division. By this means, each of the divisions, A B, B C, &c. may be divided into 5 parts or minutes, by shifting the moveable limb or vernier H I to any part of the quadrant where the sub-division is required.

VERNIER, Chromatic. (See *Chromatic*.)

VERSED SINE. (See *Sine*.)

VERTEX. The top of any thing ending in a point, as the vertex of a spire, pinnacle, &c.

VERTEX OF A CONIC SECTION. The extremity of the abscissa.

VERTEX, or VERTICAL POINT. In astronomy, the same as zenith.

VERTICAL. Erect; that is, perpendicular to the horizon, as a vertical plane.

VERTICAL ANGLES. (See *Angle*.)

VERTICAL CIRCLE, is a great circle of the sphere passing through the zenith and nadir of a place: they are also called azimuth circles. The meridian of a place is always a vertical circle

VERTICAL, Prime. (See *Prime*.)

VERTICAL OF THE SUN, is that vertical circle which passes through the centre of the sun at any moment of time; thus the shadow thrown by the gnomon of a dial is always a vertical of the sun at the time when the shadow is observed.

VERTICAL DIAL. One which is placed vertically with the horizon, such as those upon church walls, &c.

VERTICAL WINDMILL. (See *Windmill*.)

VESPER. One of the names formerly given to the planet Venus.

VESTA. One of the four new planets which revolve between the orbits of Mars and Jupiter. It may be seen on a clear evening by the naked eye, appearing like the very smallest star. Its revolution around the sun is in 3 years, 66 days, 4 hours. Its size has not yet been determined, but it is known to be very small, though its aspect is extremely brilliant.

VESTIBULE. A porch; also the hall of a house, or an anti-chamber.

VIADUCT. An elevated erection, usually consisting of a series of arches, and similar in construction and appearance to an aqueduct, except that it is used for the conveyance of a road or railway, instead of a canal or other body of water.

VIA LACTEA. (See *Galaxy*.)

VIBRATING ELECTRO-MAGNET. (See *Bird's Contact Breaker*.)

VIBRATING STEAM ENGINE. The great loss of power and inconvenience of the working beam of a steam engine, suggested numerous alterations in its structure to obviate the necessity of this part; hence arose the

bell crank engine, the vibrating engine, &c. In this last the piston rod is connected at once with the crank of the fly wheel; the steam cylinder vibrates upon two hollow gudgeons below; to one gudgeon is attached the steam pipe, and underneath the cylinder is the four-way cock, so arranged that as the cylinder vibrates, the cock is turned backwards and forwards, admitting the steam alternately above and below the piston; the waste steam being carried off by a second pipe fitting into the other gudgeon, or otherwise, as most convenient. The following cut shows the general arrangement. It is to be observed that vibrating engines are liable soon to get out of order, in consequence of the constant shock given to the working parts, whereby the stuffing box and piston wear unequally.

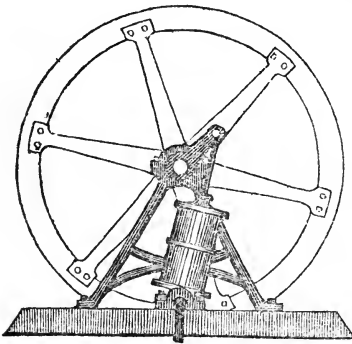

VIBRATION. A rapid alternating motion like that of a pendulum. Vibration, in electricity, is known as a quantity of the fluid intermediate between a spark and a shock. It occurs when using a very small Leyden jar, such as that belonging to the medical bottle. With a moderately sized machine, vibrations may be given almost as rapidly as sparks, and yet be felt like shocks, which in fact they are.

VIENNA GREEN. The same as Schweinford green; it is an arseniate of copper.

VIGNETTE. An ornamental drawing without any determined border or regular edge, introduced into a page of a book, but not occupying the whole of it. It was originally a wreath of vine leaves, whence the name.



VIGNETTE MOULDING. A moulding ornamented or enriched with vine leaves, grapes, or tendrils.



VICE. An instrument consisting chiefly of a pair of stout jaws or chaps, which are brought together by the aid of a screw, to compress or hold fast any substance placed between them.

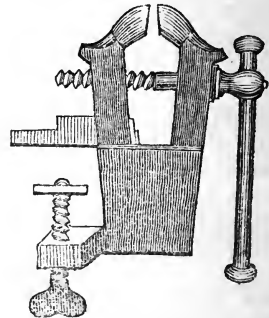

VILLA. A country house or rural mansion, mostly of an ornamental style of building.

VINCULUM. In algebra, a mark or character, either drawn over or including a quantity when it is compounded of several letters or terms to connect them together as one, and show that they are to be multiplied or divided, &c. Thus $a + b \times c$, or $(a + b) \times c$ denotes the product of c , and the sum $a + b$ considered as one quantity.

VINEGAR. See *Acetic Acid*, with which it is synonymous.

VINEGAR, Aromatic. (See *Aromatic*.)

VINEGAR, Radical. This differs from the acetic acid, procured by the acetous fermentation only, in being prepared by the decomposition of an acetate, such as those of lead or zinc.

VINEGAR OF SATURN. Solution of the acetate or sugar of lead.

VINEGAR OF WOOD. (See *Pyroligneous Acid*.)

VINOUS FERMENTATION. (See *Fermentation*.)

VIRTUAL VELOCITY. (See *Velocity*.)

VIS. In writings on physical and mathematical subjects, signifies force, as *vis absoluta*, absolute force; *vis motrix*, moving force. These Latin expressions are now seldom used in English treatises.

VIS INERTLE, or POWER OF INACTIVITY, is defined by Sir J. Newton to be a power implanted in all matter, by which it resists

any change endeavoured to be made in its state, whether of rest or of motion; for example, a horse would be a long time in putting in motion a large ship, or increasing its speed, if before in motion, because of its vis inertiae, which must first be overcome.

VISIBLE. Any thing that is an object of vision or sight; or, any thing whereby the eye is affected so as to produce the sensation of sight.

VISUAL. Relating to sight or seeing, as visual angle, visual ray, &c.

VISUAL POINT. The point of vision from which an object is viewed, synonymous with the point of sight; (see *Perspective*.) So the visual ray is the thread or beam of light reflected to the eye from a certain point of the object.

VITAL AIR. (See *Oxygen*.)

VITREOUS ELECTRICITY. (See *Du Fay*.)

VITRIFIABLE COLORS. Such pigments and compositions as come to the state of glass when submitted to the proper degree of heat. (See *Enamel* and *Glass Staining*.)

VITRIFICATION. The turning of any thing into glass.

VITRIOL. The old chemical, and still the common appellation of sulphuric acid, and of many of its compounds: thus vitriolic acid, or oil of vitriol, is sulphuric acid; blue vitriol, or Roman vitriol, is the sulphate of copper; green vitriol is green sulphate of iron; vitriol of Mars is the red sulphate of iron; and white vitriol the sulphate of zinc.

VITRUVIAN SCROLL. A particular ornament used in classical architecture.



VIVIAN AND TREVETHICK. (See *Trevethick*.)

VOID SPACE. (See *Vacuum*.)

VOLATILE ALKALI. (See *Ammonia*.)

VOLATILE OILS. (See *Oils*.)

VOLATILITY. That property of bodies by which they are disposed to assume the vaporous or elastic state, and quit the vessels in which they are placed.

VOLCANO. A burning mountain, hollow below, and communicating in all probability with cavities still deeper than its own, from which it is supplied with fire, and ignited materials; these it usually throws up at uncertain intervals, in the state of ashes or of liquid lava, through one or more external apertures or craters. Some volcanoes throw up torrents of water, others mud. There are in the world, perhaps, 200 volcanoes. Those, with the effects of which we are best acquainted, are Hecla, in Iceland; Etna, in Sicily; and Vesuvius, in Italy. Volcanoes

are also thought to exist in the moon, of far greater power and magnitude than those of the earth.

VOLTA'S AIR LAMP. A contrivance for procuring a light instantaneously. One of the illustrations shows the external appearance of the lamp; the other, the section of it. In the latter, A represents a leaden bottle, which has a pipe from the top of it, through the bottom, and extending some distance below, as B. The case is divided into two compartments; the lower one, into which B dips, is filled with water. The bottle A is for the generation of hydrogen gas, by the aid of iron, sulphuric acid, and water; the gas when made passes down the tube B, through the water in the lower department, and filling the tube D and cock E. The gas having no outlet, occupies also the upper part of O, driving the water up the pipe C into the upper vessel. Whenever, therefore, the cock E is turned, the gas rushes out of a small orifice H, where there are two wires, separated from each other by a small interval. One of these wires is connected to the lower plate of the electrophorus, seen at F, and is a fixture. The other wire G is connected with the cock E, and meets the former wire near enough to give a spark, whenever the cock E is turned; and as this also lets on the gas, this is inflamed by the spark, and in its turn lights the candle in the front of the instrument.

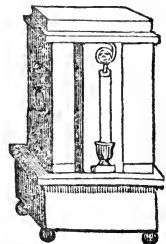
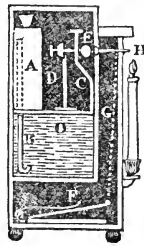

VOLTA'S CONDENSING PLATE. An electrical doubler of the form shown in the cut. The upper plate C is formed

of metal or wood, covered with tin foil, and furnished with a glass handle. B is a non-conducting plate; (a piece of baked wood, marble, or pasteboard, does very well.) A is a common gold-leaf electroscope. To use this apparatus:—Put the plate B upon the electroscope, and the plate C upon B, connected, for example, with a pointed wire extending some distance into the atmosphere.

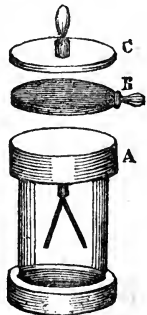

Although the pointed wire may collect, if attached to the electrometer, so little fluid as to be unappreciable, yet connected with this upper plate C, this plate will concentrate the quantity, until the plate B, by being let down upon A, will by electrical induction affect the fluid of the gold leaves, and render the experiment successful. (See also *Condensing Plate*, where another form of the instrument is figured and explained.)

VOLTA'S ELECTROPHORUS. (See *Electrophorus*.)

VOLTA'S EUDIOMETER. (See *Eudiometer*.)

VOLTAIC APPARATUS. (See various articles under *Galvanic*.)

VOLTAIC BATTERY. (See *Galvanism*.)

VOLTAIC ELECTRICITY, OR VOLTAISM. The same as galvanism, it being to M. Volta that we owe the first knowledge of the powers of voltaic circuits, as shown by him in the *couronne de tasses* and the *galvanic pile*. (See *Couronne* and *Pile*.)

VOLTAIC MAGNETS. (See *Electro-magnets*.)

VOLTMETER. An instrument for ascertaining the power of a galvanic battery, by means of the quantity of water it will decompose in a given time; and also of showing the analysis of water by galvanism. Two such instruments are described under the words *Bachhoffner* and *Faraday*, also two others under the word *Decomposing*. The principle of the following similar, but more simple and superior instrument, will be easily understood by reference to the others. It is the invention of Mr. De Moleyns. A A are two graduated tubes of glass, for receiving the two gases. B B are two binding screws, connected with the poles of the battery. C C are platina wires, united to the binding screws, and to which the platina electrodes are joined. D D is a brass bar, through which the tubes pass, and also the wires are insulated. By these arrangements all leakage is prevented, and the parts are easily cleaned.

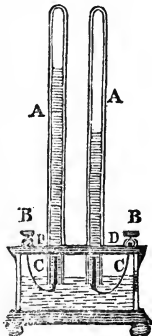

VOLTAPLAST. Such is the name given to that form of galvanic battery which is adapted to the electrotype, and of which several kinds are already described, (see *Electrotype*.) The following account of another kind has been sent us by the inventor, Mr. De Moleyns:—

“A A is a square mahogany trough, cemented inside, to make it water-tight. On the right hand is a plate of zinc B, not amalgamated. Connected with the longer wire is a plate of copper C, doubled backwards on itself into the form D represented in the figure,

forming thus a shelf, intended to hold crystals of sulphate of copper, which keep the solution saturated, through small holes in the front of the plate. When the battery is used for precipitations, this plate is removed, and the wax or other impression substituted; in this case the crystals of sulphate are placed in the other cell E. The metals and casts are suspended from brass bars which extend across and rest on the sides of the trough; and there is an arrangement by which the metals may be approached nearer the diaphragm or drawn back, as occasion may require, so that the force of the current may be regulated to a nicety. A saturated solution of muriate of ammonia, diluted with soft water, is used in connection with the zinc; thus dispensing with acids and their accompanying annoyances. The diaphragms in these batteries are prepared by a peculiar process, not yet made public, which greatly increases their conductivity.” As the diaphragms are not described, it may be stated that a division of plaster of Paris, brown paper, wash-leather, or parchment, will do equally well.

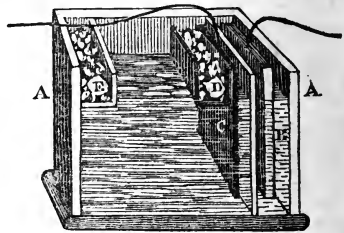

VOLUMN. The *apparent* space which a body occupies is termed its *volumn*; the real space which such a body occupies, or its real bulk of matter, is called its *mass*. The relation of the mass to the *volumn*, or the quotient obtained by dividing one by the other, is its *density*; and the empty spaces or voids which render the *volumn* larger than the mass, are its *pores*; or in the case of fluids, the interstices between its particles.

VOLUTE. A principal ornament in the Ionic, Corinthian, and Composite capitals. There are eight angular volutes in the Corinthian and Composite capitals, and eight

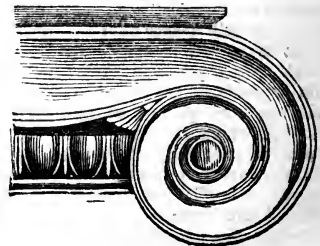

smaller ones between them. In the Ionic three are but four. The cut on the preceding



page shows the Ionic volute; the annexed is that of the Corinthian, taken from an elegant

Greek example. The volutes of the Corinthian are much more varied. The inner volutes are generally called caulicoles. There are, in every Corinthian capital, eight of the larger, and as many of the smaller. The volutes of the Composite order partake of a mixed character, being intermediate between the Ionic and the Corinthian; the scroll portion or head being sometimes plain; and at others ornamented with leaves, running in between the channels. The most celebrated example is the Arch of Titus at Rome.

VORTEX. (See *Whirlwind* and *Whirlpool*.)

VORTICES OF DESCARTES. (See *Cartesian*.)

VOUSSOIR. The stones which form an arch.

VULGAR FRACTION. (See *Fraction*.)



A letter which equally partakes of the nature of a vowel and a consonant, being the latter when at the beginning of words and syllables, but a vowel in every other situation. In English, *w* is scarcely used as a vowel, except when united to another vowel, as in *strew*, *show*, &c.; though in Welsh the *w* is used alone, as in *cwm*. The sound of *w* as a consonant is nearly uniform; as a vowel it is quite arbitrary, and seems to depend upon custom alone, as is seen in the following examples:—*sew*, *low*, *saw*, *brew*, *cow*, *bow*, and *sow*, which two last, with some other words, have each two sounds. *W* not being known in the ancient languages, is, of course, not found in the remains of antiquity, nor do we use it as an abbreviation, except *W.*, as *west*, and *wk.*, as *week*.

WABBLE. A hobbling unequal motion.

WADD, is a provincial name of plumbago in Cumberland, and also of an ore of manganese in Derbyshire.

WAFER. A thin pasty material; used to close letters, and stick other smaller articles together. Wafers are of four kinds. *Paste* or *common* wafers, which are made of wheat flour and water, with some coloring matter. The thin fluid paste is poured on to a square iron frame, made of a very little depth; a second frame or rather cover is put over it, which squeezes out the superfluous paste, and being warm, the iron at the top and bottom bakes the paste into a thin cake, which is afterwards punched out into form. Second, *transparent* wafers, which are made of fine glue, poured out on to a marble slab; when cold and dry, it is punched out with

proper shapes. Third, *gum* wafers, lately much used, are merely colored paper, gummed on the blank side, and cut out with a stamp that at the same time impresses them with a device or letter. Fourth, *medallion* wafers, for these, dies with various devices are taken; a mixture of flake white or ceruse is painted over the depressed portions of the die; the superfluity of this is wiped off with the hand, and dissolved isinglass afterwards poured over the whole. When dry, and taken off, the wafers present the appearance of a white figure upon a different colored ground.

WAGGON. A four-wheeled carriage for the conveyance of heavy goods and materials.

WAGSTAFF'S ELECTRO-MAGNETIC MACHINE. This is a coil machine, which varies in its form and method of breaking contact, (see *Bachhoffner*, *Bird*, *Sturgeon*, &c.) Its principle however is the same. A is the double coil of insulated wire. B a bundle of straight iron wire. C a break-wheel, better seen in the side-cut K. It is of brass, with a brass axis, and several cavities cut in the circumference, which are filled with pieces of ivory, so that upon turning the wheel the wire at the top of it is in contact with the brass, or not, according to whether it touches the metal or ivory, and contact is rapidly renewed and broken. The two ends of the primary coil are connected with B and D, and with the centre of the break-wheel, upon the circumference of which rests another wire that goes under, and is secured by I. It passes on the under side from I to H, and is then secured by H. The ends of the secondary wire are secured by the balls E and F. The ends of the battery are connected with G and H. L shows the wires beneath the stand;

L L L

the points near the centre is where they issue from the coils, thence passing to the balls.

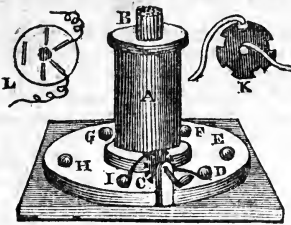

WAGSTAFF'S WIRE COVERING MACHINE. This simple and effective machine was invented to cover with silk or cotton the wire used for electro-magnetic purposes; but it is equally applicable to cover violin strings, or wire for bonnets. The framework is of wood. A B the foundation of it. C is a drum, upon which the wire which is to be covered is first wound. This wire passes round the pulley L, through the tube D, round the pulley E, and on to the wheel F, upon the back of which is a groove to receive it, of a diameter exactly equal to the drum C. When the handle G is turned round it moves the pulley J; this by a cord turns the smaller pulley I; and I is connected by a bent wire with the bobbin of cotton K; so that as I is turned, the bobbin rotates about the wire to be covered, and in fact covers it; at the same time it is drawn forward very slowly, in consequence of the handle G turning at the same time the toothed-wheel F, so that the wire is unwound at one end, well and rapidly covered by cotton, and wound up on a reel, all by turning a handle.

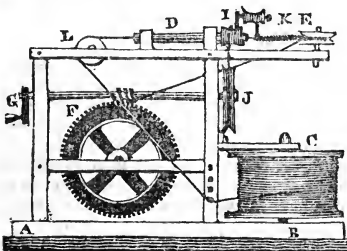

WAINSCOT. The lining of walls, constructed of wood, and most generally panelled; when it does not reach the top of the walls it is called *dwarf* wainscotting; also from the circumstance of a soft and straight-grained species of oak being used originally for this purpose; such timber is still, although mostly superseded by fir, called wainscot. This timber, and by the same name, is now chiefly used for the inner part of drawers and other furniture.

WALL. A fabric of stone, brick, chalk, or clay, erected around gardens, to inclose or form a part of houses, &c., either as defence, inclosure, or support for other parts. Walls are, in ordinary circumstances, built erect or vertical on both sides: in embankments they may be *battered*, that is, be made wider at the bottom; and in both cases, if of great height, and not tied by cross walls, they should be strengthened by piers of stronger work erected at intervals. In the walls of houses, as they are liable to be broken through by apertures for doors and windows, they are strengthened by bond timbers placed even with the inner surface, and running horizontally through the wall. Brick walls are known by their thickness, as 4-inch work, that is the thickness of a brick laid *flatways*; 9-inch work, or the thickness of a brick *lengthways*; brick and a half; 2 bricks; 2½ bricks, &c. Stone walls are distinguished not only by their thickness, but also by the character of surface given to the stones. (See *Masonry*.)

WALLS, Cased, those that are faced up anew, in order to cover an inferior material, or old work gone to decay.

WALLS, Abutments in. The beds that are prepared for the springing of an arch.

WALL PLATE. A beam of timber lying upon a wall to rest the timbers of the roof upon, or the joists of a flooring.

WALLACE'S EIDOGRAPH. This instrument is for copying drawings accurately at an equal, reduced, or enlarged size from the original. A B is a bar of wood sliding along the centre pulley C, which is fixed to a table. This bar is graduated, and, according to the lengths from the two ends, so will the size of the drawing be regulated. E E are two pulleys turning on their centres, and having the graduated sliding bars F F passing through or under them; a cord connects the pulleys E E, which are furnished with guards at K K, to keep the cord from slipping. One of the points G, carries a tracing point, the other G a pencil, from which proceeds a string to lift it from the paper when no mark is to be made, E and F being set at such lengths as correspond with the two ends of the centre bars, the pencil will mark upon a piece of paper placed beneath whatever the tracer passes over.

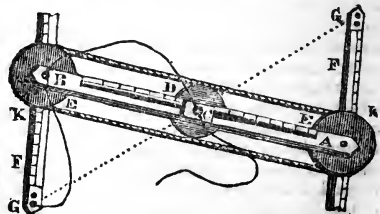

WALLOWER. (See *Trundle.*)

WAREHOUSE. An erection for the preservation of goods and materials.

WARP. The layer of threads, which extends the length of the piece of cloth, calico, &c. which is to be woven.

WASH. The fermented wort of the distiller.

WASHERS. Small pieces of metal, placed under a nut to reduce friction.

WASHING OF ORES. The purifying of any ore of a metal, by means of water, from earths and stones, which would otherwise render it difficult of fusion. Washing of a picture, is the slightly coloring of it with a very light and thin tint, to indicate various colors, which the mere drawing will not give, for the colors of different marbles, flowers, &c., cannot always be indicated by words or drawing, though a very slight wash will give them accurately. The coloring of maps is a kind of washing.

WASH LEATHER. (See *Shamney.*)

WASTE WEIR. A channel constructed to carry off surplus water from a mill, canal, &c., when in too great abundance for its intended purpose.

WATCH. A small time-keeper, to be carried on the person.

WATER. A well known fluid, which, when pure, has neither color, taste, nor smell. When existing naturally, it is however never pure, the nearest approach to purity being in snow or rain water. It is the material from which the specific gravity of all liquid and solid bodies is determined, itself being reckoned as *one*. We give to water various appellations, according to its contained ingredients or its source; thus, *soft* water is known as such as is nearly pure, and which combines well with soap. *Hard* water is contaminated with various earths and minerals, particularly lime in different states. If it contain such substances as are beneficial to the human constitution, we call it mineral or *medicinal* water. The water of the sea contains the muriate of soda. Water was supposed by the ancient chemists, indeed, till within a little more than half a century, to be a simple substance; it is now known to consist of oxygen and hydrogen. Water may be formed artificially by exploding these gases in the eudiometer, (see *Cavendish*), by the air-pistol, the electrical spark; or the fact of its composition may be proved by analysis with the galvanic decomposing apparatus. (See *Decomposing*.)

WATER OF CRYSTALLIZATION. Many salts require a certain proportion of water to enable them to retain the crystalline form, and this is called their water of crystallization. Some retain this so feebly, that it flies off on exposure to the air, and they fall to powder. These are the efflorescent salts. Others have so great an affinity for water, that

their crystals attract more from the air in which they dissolve. These are the deliquescent.

WATER CEMENT. (See *Puzzolana.*)

WATER COLORS. Such pigments as are miscible with water; these are usually sold in small rectangular cakes, made by grinding the proper pigment along with water until it makes a uniform paste; to this a little size is added, and then a portion of it, sufficient for a cake, is pressed into a mould, which has been slightly oiled ready to receive it.

WATER COLOR PAINTING. A painting colored with such pigments as are miscible with water. There is not in water color painting so much breadth, brilliancy, and force as in oil, but in general more light, airiness, and transparency.

WATER GILDING. (See *Gilding.*)

WATER HAMMER. A tube of glass, about a foot long and half an inch internal diameter, with a bulb at one end. This is exhausted of air, partly filled with distilled water, and hermetically sealed. If it be now turned upside down suddenly, the water having no air to intercept its motion, will fall to the lower end of the tube, and at the same time produce a loud report, like the blow of a hammer. It is made by pouring water into a tube of glass of proper size, and sufficiently strong to bear the pressure, then boiling the water, and when steam only occupies the tube, hermetically sealing it.



WATERING OF STUFFS. (See *Tabby.*)

WATER LEVEL. (See *Level.*)

WATER-MILL, or WATER-WHEEL. Any wheel turned by running water. According as the water is applied, they are called *Under-shot*, *Overshot*, and *Breast-Wheels*, (which see.) The first is used only in streams, the water striking against the lower part. In the overshot wheel, the water passes over the top; and in the breast-wheel, the water falls perpendicular to the buckets or float-boards.

WATERPOISE. (See *Hydrometer.*)

WATER-PROOF. Any thing which resists the passage and action of water.

WATER RAM. An ingenious machine whereby water is raised much above its level, by the momentum of a larger stream than that raised. Suppose that the water from a butt be required to be carried to a cistern at the top of a house, it may be done by this means. A pipe is led from the butt to the ram, and to a valve beyond it, which is forced down and kept open by the weight T. The water rushing down the pipe Q, acquires momentum, and striking

against the underside of the valve S, closes it. The course of water is stopped, but the momentum cannot be so easily overcome, therefore that part of the column nearest to the butt still endeavours to escape, and as it cannot do so through R it opens the valve in the ram, and rushes up the pipe X. The momentum ceases, and S again opens, and allowing a fresh flow of water, occasions the former impulse to be renewed, and more water to pass into X. So rapid is the action of this machine that the valve S is in continual and incessant vibration.

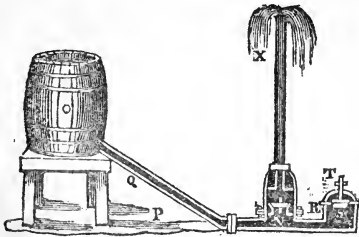

WATER-SHOOT. A wooden trough for the discharge of water.

WATER-SPOUT. A remarkable kind of meteor, consisting of a moving column or pillar of water. Its first appearance is in the form of a deep cloud; the upper part of which is white, the lower black. Soon afterwards there hangs, or rather falls down, what is properly called the spout, resembling a conical tube, largest at the top. This varies in length, and generally assumes a waving or rotatory motion. The sea beneath is always more or less agitated, drawn up and scattered in spray: after a time the spout recedes into the clouds, and the whole passes away. This phenomenon is accounted for by electrical attraction. Waterspouts occasionally pass over the land, and when they meet with any thing to draw off their electricity, they break and deluge the ground beneath.

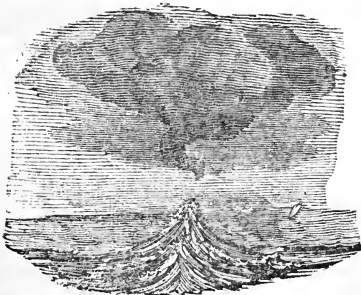

WATER-TIGHT. That degree of tightness in a vessel which prevents the passage of

water through it. Thus a cask must be water-tight, or its contents will leak out; a buoy must also be water-tight, that the water may not get in, and thereby sink it.

WATER-WHEEL. (See *Water-Mill*.)

WATER WINGS. The walls erected on the banks of a river next bridges, to secure the foundations from the action of the current.

WATER-WORKS. The name applied to every description of works, for raising and sustaining water-wheels, sluices, and other hydraulic structures; and particularly to works erected to supply towns and cities with water for the use of the inhabitants.

WATKINS'S HELICAL ROTATIVE WIRE. This instrument shows the effect of an electrical current, passing along a wire, twisted heliacally around the pole of a magnet. Let A B be a horse-shoe magnet, fastened vertically to the stand by a screw C. Upon each arm of the magnet is a circular mercury channel E E, furnished with mercury cups, and fastened to the magnet by side screws. F F are the two heliacal wires; they have mercury cups at top, and are supported by points on the poles of the magnet. G is another mercury cup. I a cross bar, appended to the standard H. When a current is sent through the coils of wire, in any direction, they will rotate around the poles of the magnet within them.

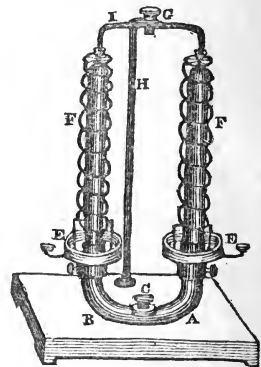

WATKINS'S ROTATING MAGNETS. It will be seen that this instrument is but a modification of another, described under the word *Sturgeon*. It acts upon the same principle, and like the other may be of varied form. One of the neatest is as follows:—A B are two bent magnets. C C are two wires to support them. D D and E E are mercury cups, the wires of E E dipping into D D. From the lower ends of the magnets proceed two wires H and I, that are long enough to dip into the troughs for mercury F G. When the electrical current is passed either down or up both magnets, they will rotate in the

same direction with each other; but if the current be passed down one and up the other, they will rotate both the same way.

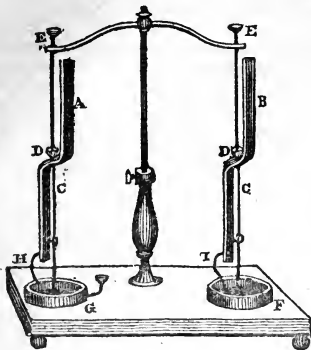

WATT'S AND BOULTON'S STEAM ENGINE. One of these engines, for there are two, is already described under the word *Steam*. The other, called usually Watt's single engine, is as follows:—This was invented before his admirable contrivances of the governor and parallel motion. It might be thought unnecessary to show more than the representation of it, yet it differs so very materially from former engines in its condensing apparatus, its valves, and trussed working beam, as to claim attention to these particulars. A is the cylinder. B the piston. C the steam pipe. D the throttle valve. E the

lower steam valve. F the passage to the cylinder. G the pipe leading to the condenser h. I is the air pump, opening into the hot water cistern by the valve. L the hot water pump. M and N the tappets, which work the valves. O the cold water pump, which supplies the cistern R.

WAVE. A volumn of water, elevated by the action of the wind, &c. upon its surface, into a state of fluctuation, and accompanied by a corresponding cavity between each two waves. Natural waves are such as arise from this cause, and are found only in open seas. Artificial waves, or breakers, are those motions of the water, occasioned by objects passing through it, by its beating on the beach, or against rocks, or other obstacles.

WAX. The substance which forms the cells of bees, and also a vegetable product. Bees' wax is yellow, has a peculiar smell, derived from the honey lodged in the cells. Those cells in which no honey has been deposited are scentless and white, called *virgin wax*; a name also given to common wax when purified and bleached, by exposure to air, light, and moisture. Wax is often adulterated with starch and with mutton suet.

WAX, Mineral. A bituminous substance, found at the foot of the Carpathian mountains, near Slarick.

WAY-WISER. (See *Perambulator*.)

WEATHER. Denotes the state of the atmosphere, with regard to heat and cold, dryness and moisture, wind, rain, hail, &c.

WEATHER-BOARDING. The nailing of boards upon each other, so that the upper laps over the under board, and thereby throws off the wet; the boards used for this purpose are cut thicker at one edge than the other, and are called *feather-edged boards*, or more properly, but less frequently, *weather-edged boards*.

WEATHERED. When horizontal stonework, such as window sills, cornices, coping stones, battlements, &c., are sloped off to throw off the wet, they are then called *weathered*.

WEATHER-GLASS. (See *Barometer*.)

WEATHERING. Among millwrights, is the angle at which the sails of a windmill are set to receive the impulse of the wind.

WEATHER, or WATER MOULDINGS. (See *Dripstones*.)

WEATHER TILED. The covering of an upright or wall with tiles.

WEAVING. The art of manufacture of textile fabrics in a loom.

WEDGE. One of the five mechanical powers or simple engines, being a geometrical wedge or very acute triangular prism, applied to the splitting of wood, rocks, or raising heavy weights. The wedge is the most powerful of all the simple machines, having an almost unlimited advantage over all the other simple mechanical powers, both as it may be made

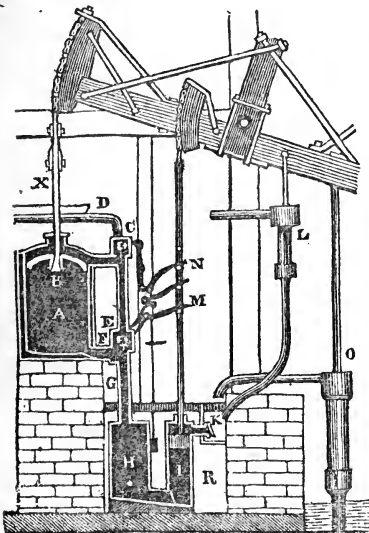

very thin in proportion to its height, in which consists its own natural power; and as it is urged by the force of percussion, the greatest of all forces. To the wedge may be referred all edge-tools, and tools that have a sharp point, in order to cut, cleave, slit, split, chop, pierce, bore, or the like, as knives, hatchets, &c.

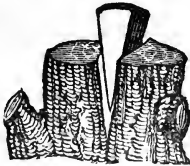

WEDGEWOOD'S PYROMETER. An instrument for ascertaining very great degrees of

heat. Its indications depend upon the contraction of pure clay when much heated. This reduction of heat is first observed when the clay acquires a red heat, and continues to increase until vitrification ensues; the contraction of volume being permanent, and amounting in the whole to about one-fourth. The pyrometer consists of a gauge of brass of two straight pieces, 2 feet long, fixed upon a plate, a little nearer to each other at one end than at the other, the space between them at the widest end being $\frac{5}{10}$ of an inch, and at the narrowest $\frac{3}{10}$. The converging pieces are divided into inches and tenths. The piece of clay, the contraction of which is to be measured, is made of a cylindrical form, but flattened on one side, and of such a size as to be exactly adapted to the wider end of the gauge, so that it may slide farther in, in proportion to the degree of heat applied to it. The scale of this pyrometer proceeds from 1 to 240; 1 is the heat at which zinc melts, equal to 700° Fah.; 240° of Wedgewood is equal to 32277° of Fah., a greater heat than that of the hottest furnace, this latter being about 160° of Wedgewood, or 21877° of Fah. The heat at which enamel colors are burnt on is 6° W. (Wedgewood); flint glass is poured at 29°; plate glass at 57°; Delft-ware baked at 41°; least welding heat of iron 90°; greatest 95°; stone-ware baked in at 102°; greatest heat of a smith's forge 125°; cast iron melts at 130°.

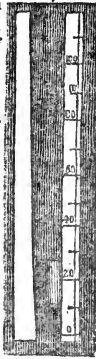

WEIGHING BEAM. (See *Balance*.)

WEIGHING MACHINES. (See *Balance*, *Counter-weighing Machine*, *Danish Balance*, *Steelyards*, &c.)

WEIGHT. In mechanics, denotes anything to be raised, sustained, or moved by a machine, as distinguished from the power, or

that force by which the machine is put in motion. Weight, in commerce, is a certain known and standard quantity of a heavy material, used together with a balance, steelyard, &c., to ascertain particular quantities of goods, suspended so as to counterpoise the weight. In natural philosophy, the weight of an object is synonymous with its specific gravity, multiplied by its bulk; or in other words, it is the measure of the amount of gravitation in any body, compared with that of other bodies.

WEIGHT OF THE ATMOSPHERE. (See *Atmosphere*.)

WEIR. (See *Dam*.)

WELD. The dried stalks, leaves, and flowers of an annual herbaceous plant, called *Reseda luteola*. They are used by the dyers as affording a brilliant and durable yellow color.

WELDING. The property of uniting together and incorporating with each other two or more pieces of metal, by heating and hammering. The property of welding or becoming thus united is only possessed by certain metals, particularly by iron and platinum.

WELF. (See *Woof*.)

WELL. A narrow and deep pit, dug in the ground for the purpose of obtaining water; for burying valuable matters from the devastation caused by fire; or, in some cases, for the conveyance of workmen and goods up and down from a mine beneath: in this latter sense it is mostly called a shaft.

WELLS, Artesian. (See *Artesian*.)

WELL-HOLE. In building, the space inclosed by the walls of a circular staircase. Some builders confine the term to the void space left in the middle of such a staircase, and which opens a cavity from the top to the bottom of the edifice.

WELL STAIRCASE. A winding staircase, the walls of which are built round so as to resemble a well.

WELTER'S SAFETY TUBE. (See *Tube*.)

The following different form is often given to the safety tube, for the greater convenience of performing certain experiments; its principle is the same as that before described. The two ends dip into various of Woolf's bottles, while the tube may be either left open for particular gases to escape, or it may be loaded by quicksilver, oil, or spirit being poured into it.

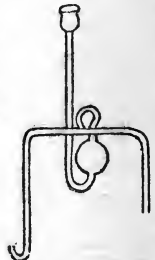

WEST. One of the four cardinal points, being that opposite to the east, and that nearest to which the sun sets.

WET DOCK. (See *Dock*.)

WHALEBONE. The name of the horny laminae found in the mouth of the whale, which by the fringes upon their edges, enable the animal to allow the water to flow out from between its jaws, but to catch and detain the small fishes upon which it feeds. There are about 300 blades of whalebone in the mouth of each fish; these are of various lengths, from 12 or 14 feet to 3 or 4. Whalebone is used for the ribs of umbrellas; to stiffen stays; and for the frame-work of some hats. Heated by steam it softens, and may then be moulded to many forms like horn; in this way snuff-boxes and the knobs of walking sticks are sometimes manufactured.

WHEEL. In mechanics, an engine consisting of a circular body turning on an axis, for enabling a given power to overcome or move a given weight or resistance; or in many cases as a roller to diminish friction. Wheels are extremely diversified in shape as they are in application. (See the words *Bevelled, Break, Cam, Crown, Cogged, Tooth, Trundle, Pinion, Ratchet, Spur, Water-Wheel, Escapement, Fly, Friction, Heart, Dished, Rag, &c.*)

WHARF. A firm landing place, built beside the water, for the convenience of loading or unloading ships, barges, or other vessels, and therefore usually furnished with cranes and various appendages, according to the nature and extent of the business to be performed.

WHEEL, Persian. (See *Noria.*)

WHEEL, Sun and Planet. (See *Sun.*)

WHEEL AND AXIS. (See *Axis in Peritrochio.*)

WHEEL RACE. The place in which a water-wheel is fixed.

WHETSTONE. A kind of slate, by which various tools are whetted or sharpened, after having been ground by a rougher stone to the requisite shape and bevel. Whetstones go by the names of Turkey stone, Charley forest, hones, snake-stone, &c.

WHIMS. Large capstans connected with the shafts of mines, and worked by horses.

WHIP. To bind two rods or bars together with twine or wire; also the length of the sail of a windmill measured from the axis.

WHIRL. A rotatory motion given to any thing.

WHIRL, Electrical. (See *Flyer.*)

WHIRLING TABLE. A machine intended to represent the several phenomena in philosophy and nature, relative to the power of the centrifugal force, particularly in its effects upon the shape of the earth and planets. The whirling table consists of a steady foot-board A, with a large wheel B, grooved around the edge, turning upon it. A cord passing round this wheel passes also over a pulley C; to this is attached an arm D, with two uprights

E and F. Upon the uprights, and also upon the centre, rest two glass tubes, closed at both ends, and holding air, water, and small shots. While the machine is at rest, the shots, being the heaviest, will occupy the lower part of the tubes; but when rapidly whirled round, by turning the wheel B, centrifugal force will so act upon the tubes as to drive the heaviest matter most outward. The shots, therefore, will be found at the top of the tubes, the water next, and the air at the bottom.

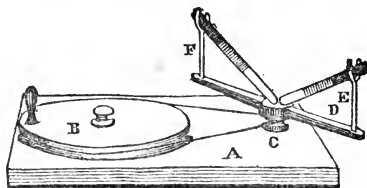

WHIRLWIND. A sudden, rapid, violent motion of the air, in circular whirling directions.

WHIRLPOOL. A body of water in certain seas and rivers which runs rapidly round, forming a sort of cavity in the middle; the same as is occasioned by water running down a funnel.

WHITE. A negative color; the effect of the admission of light upon any object which reflects it *directly*. It is, therefore, the color most significant of light, and more especially is that which is produced by the natural combination of the rays of the solar spectrum. (See *Prismatic Colors.*) Numerous bodies of this color are used as pigments by the painter, as ceruse, flake white, constant and permanent white, Krems white, &c.

WHITE COPPER. (See *Tutenay.*)

WHITE ENAMEL. (See *Enamel.*)

WHITE FLUX. (See *Flux.*)

WHITE LEAD. The white oxide of lead, used for numerous purposes of painting, and also, instead of glue, for such joints of show boards, rails, &c., as are exposed to the weather, and for the uniting of water-pipes, steam engine boiler joints, and numerous similar purposes.

WHITE METAL. A kind of queen's metal, made as follows:—Fuse together 10 ounces of lead, 6 ounces of bismuth, and 4 drams of regulus of antimony; or else, 2 pounds of regulus of antimony, 8 ounces of brass, and 10 ounces of tin: a third receipt is, 1 pound of brass, 1½ ounce of zinc, and ½ an ounce of tin.

WHITE, Permanent. Sulphates of barytes.

WHITE TOMBAC. (See *Tombac.*)

WHITING. Chalk cleared of its grasser impurities, then ground in a mill, mixed with water, made up into small loaves, and dried.

WICKET. A small door made in a gate, or by the side of a gate.

WINCH. A handle acting in the nature of a crank, for the moving of any description of machine.

WIND. A sensible current in the atmosphere, arising from the various conditions of heat and cold that affect it, from the action of the sun and other causes: for example, if one portion of the atmosphere be heated by a bright sun, the air will ascend, and its place below be filled by air of a less temperature, and thus a current be established; which, when of sufficient magnitude, will be perceptible to our senses, and be known as wind. Thus the sun, when passing through the northern signs of the zodiac, heats the air to the north of the equator, a current rushes therefore from the south, occasioning a constant wind for six months in the same direction. For the other half of the year the wind will blow always from the north, and at the period of the equinoxes, when these winds change their courses, the atmosphere of the whole earth is much agitated, whence what are called equinoctial gales occur, while the former are called monsoons, or trade winds, they blow either NE or SE; the eastern direction being caused by the rotation of the earth on its axis. The *variable* winds of temperate regions depend also upon other causes, such as evaporation, the fall of rain and snow, which occasions strata of unequal density, the neighbourhood of mountains, state of electricity of the air, &c.

WIND GAUGE. (See *Anemometer*.)

WIND GUN. (See *Air Gun*.)

WINDLASS, or WINDLACE. A machine for raising weights, in which a rope or chain is wound about a cylindrical body, moved by several levers, or, as in the case of a windlass for a well, by a handle. The cut shows an ordinary windlass for the latter purpose; A B being a cylinder upon which the rope is coiled. C the winch to turn it; and D the bucket. The action of the whole is obvious.

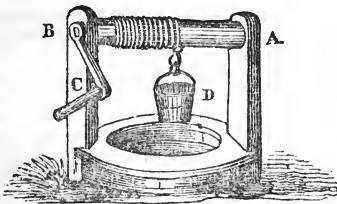

WINDMILL. An instrument turned by the wind, intended to grind corn, and for other purposes. Windmills may be *horizontal* or *vertical*.

WINDMILL, Vertical. That which is commonly seen consists of a vertical shaft, fur-

nished with a nearly horizontal spindle at the upper end, and which bears the sails. To enable the whole to turn round so that the sails may catch the wind at any point, there are two methods: one where the upper part rests upon a firm round post or tree, cut down to about 12 feet from the top, the upper end resting in a socket; thus the whole mill turns together. The second method is called a *smock* mill, in which the head only is capable of motion.

WINDOWS. Those apertures in walls through which light is admitted to the interior of buildings.

WINDOW SHUTTERS. Those wooden or iron doors by which windows are sometimes closed.

WINE, Oil of. (See *Oil*.)

WINE, Spirit of. (See *Spirit*; also *Alcohol*.)

WINE STONE. Synonymous with tartar.

WINZE. In mining, a small pit or shaft sunk from one level to another for the purpose of ventilation.

WIPER. A cam, eccentric, or projecting piece attached to a wheel, in order to produce a sudden motion to something which strikes against it in its revolution. (See *Break Wheel*.)

WIRE COVERING ENGINE. (See *Wag-staff*.)

WIRE-DRAW. To reduce a wire, pipe, or other longitudinal body exceedingly in the transverse section, and at the same time increasing it in length.

WIRE-GAUZE. Wire woven into a surface, in the same manner as vegetable fibres are into cloth, or rather like a gauze or fine network. Wire-gauze is used extensively for window-blinds, and as the cover for Davy's safety lamp, it having the peculiar property of not suffering flame to pass through it.

WIRTEMEURG SIPHON. (See *Siphon*.)

WOAD. A blue dyeing drug, the produce of the British plant, called *Isatis tinctoria*. Its use is now nearly superseded by indigo. The ancient Britons are said by Pliny to have dyed their skins with woad.

WOLFRAM. The native tungstate of iron and manganese. It is used by chemists for obtaining tungstic acid and tungsten.

WOLLASTON'S BAROMETRICAL THERMOMETER. (See *Barometrical Thermometer*.)

WOLLASTON'S BLOW-PIPE. (See *Blow-Pipe*.)

WOLLASTON'S CAMERA LUCIDA. (See *Camera Lucida*.)

WOLLASTON'S CRYOPHORUS. (See *Cryophorus*.)

WOLLASTON'S GALVANIC BATTERY. This is a trough battery, the outer case of which is of porcelain, with divisions across it, in number according to the pairs of elements employed. These elements are zinc and

copper plates; those of copper being doubled around the zinc, so that each zinc plate has the copper plate on each side of it: by this method of arrangement the power of the battery is very greatly increased. A strip of copper is continued from one copper plate to the zinc plate of the next pair, and so on throughout the series.

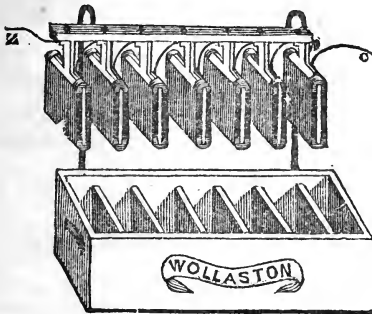

WOLLASTON'S PERISCOPE SPECTACLES.
(See *Periscope*.)

WOOD. The hardest product of vegetation, existing only in trees, and becoming deposited in them beneath the bark in each succeeding season. Acted upon by chlorine, all woods become colorless. Sulphuric acid converts them first into gum, and then, if assisted by heat, into sugar. In nitric acid wood becomes yellow, finally dissolves, and is converted into oxalic acid. In strong caustic alkaline lyes, in a hot state, wood swells, dissolves, and becomes a blackish brown mass. The uses of wood in the arts are endless, and the names and different kinds of it that are employed in England extremely numerous. Among the woods celebrated for utility rather than beauty, we may rank oak, ash, beech, fir of all kinds, birch, elm, chesnut, apple-tree, poplar, and lime-tree. Among the dye-woods are log-wood, Brazil wood, red saunders, Japan wood, Nicaragua wood, fustic, sumach, walnut, &c. The chief of the fancy or ornamental woods are mahogany, rose-wood, king-wood, tulip-wood, zebra-wood, satin-wood, ebony, bird's-eye-maple, and numerous others.

WOOD, Acid of. Pyroligneous acid, (which see.)

WOOD, Staining of. The giving a color to the surface of wood, different from that it naturally possesses, the object of which is to make it resemble other woods of a more ornamental character; thus beech-wood bedsteads are stained of a reddish purple by passing over them a brush dipped into a solution of archil, which is improved by an after-wash of a solution of pearl-ash. For a

black stain, add 1 ounce of pearl-ash to 8 ounces of log-wood, in chips; boil them together in 2 quarts of water, and apply hot with a brush; when dry, brush it a second time with a solution in a quart of water, of 1 ounce of blue-stone, and 2 ounces of copperas. To stain beech-wood like mahogany, wash it in a solution of dragon's blood in spirits of wine, or a solution of alkanet root; this will also darken mahogany. To accomplish this latter purpose, so as to make the mahogany very dark, wash it with lime water.

WOOD BRICKS. Blocks of wood cut to the form and size of bricks, inserted in the interior walls of apartments as holds for the partitioning, &c.

WOOD-CUT, or WOOD ENGRAVING. As the name implies, is a cutting or engraving on wood; also by the latter term is understood the art by which such is produced. Wood-cuts are of two kinds; in the one, the general surface of the wood is left, and the figures or designs are cut out, as is seen by reference to the word *Snow*; this is the most easily executed. In the other kind, the wood is cut away, the lines of the design only being left, as is seen in ordinary pictures and illustrations. The wood employed is, except for very coarse work, that of the box-tree, cut in slices across the grain, 1 inch thick each, and polished on one surface. In this state the wood engraver receives it. He first whitens the surface somewhat with flake white, water, and size; then with a fine hard pencil draws the design, reversing every part, so that what is, when printed, to appear on the right hand, must be drawn on the wood to the left hand; he then by the aid of gravers, or small gouges, (called scapners,) and chisels, cuts away all the parts of the wood left white, and leaves untouched the pencil lines; and as these constitute the picture itself, it will be complete when the white parts are removed. A proof is then taken by blacking it with printer's ink, laying a piece of slightly damped paper upon it, and rubbing the back of the paper with a smooth, flat, and hard substance. Wood engravings are inclosed along with the letter-press in printing. (See *Cross-Hatching, Engraver, Graver, &c.*)

WOODEN PRESS. (See *Printing Press*.)

WOOD VINEGAR. (See *Pyroligneous Acid*.)

WOOF. In weaving, those portions of thread or yarn in cloth which lie across the length of the warp.

WOOL. The produce of the coat of the sheep.

WOOTZ. The Indian name for steel.

WORCESTER'S STEAM ENGINE. The Marquis of Worcester in his extraordinary book, the "Century of Inventions," (1663,) says—"I have invented an admirable and

forceable way to draw up water by fire, which hath no bounds, if the vessel be strong enough." No description is given, but two or three engines have been contrived as illustrating the Marquis's invention. These, although called Worcester's engine, were not invented by him; and it is very doubtful whether his vague and gasconading remark was ever put in practice by himself. The engines alluded to are as follows:—The first is by Professor Millington; it is represented below.

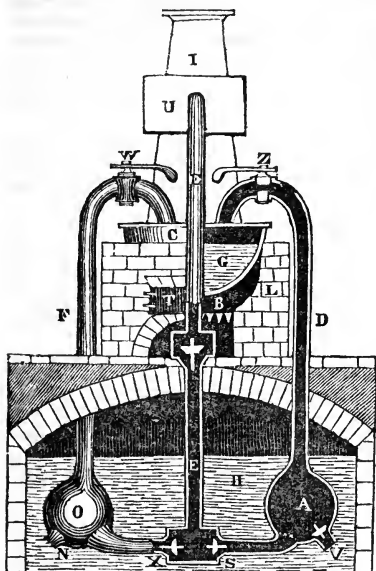

The two spherical vessels A and O have each a pipe, D and F, proceeding from them, and entering the boiler G. These pipes have two stop-cocks, Z and W. There are also four other pipes, two of them opening into the pipe E E, which is 40 feet high, and terminates in a tank U. These pipes have valves at S and X. The other two pipes, V and N, are short, and merely intended as valves between the cistern of water H, and the vessels A and O. B is the fire-grate, shown open. T the same closed. C the outside of the boiler. I the chimney. When steam is generated in the boiler, the cock Z being open, and W closed, it presses upon the water in A, drives it through S, and up E. When Z is closed, and W opened, the steam drives the water from O, while the steam in A becomes gradually condensed; a fresh supply of water running into A by the valve V. This alternate action drives the water up the pipe E; a man being employed to turn the cocks. A second contrivance, by

Mr. Stuart, also illustrates the Marquis's invention.

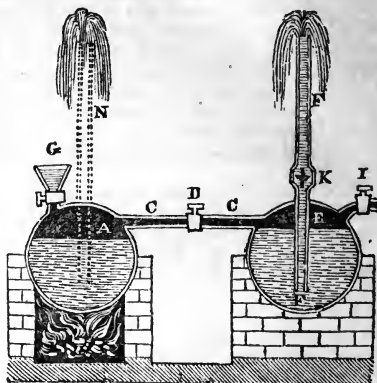

A is a boiler. C C a pipe having a stop-cock D connecting the boiler with the cold water vessel E, from which proceeds the eduction pipe F. G a pipe and funnel to supply the boiler with water. I a pipe to supply the vessel E. K a valve to prevent the return of the water from F. When the steam from the boiler is allowed to enter E, the water is raised through F, until E is emptied. When this is the case, D is shut, I is opened, and thereby E becomes filled again. The cock I is again closed, and D being opened, the first action of the steam is repeated, and water again forced up the pipe F.

WORDS, Luminous. Electrical. (See Devices.)

WORMWOOD, Salt of. (See Salt.)

WORT. The fermentable infusion of malt or grain.

WOULFE'S APPARATUS. A series of two or three necked bottles, called *Woulfe's bottles*; intended to retain the different products which are the result of chemical evaporation or distillation. The number of bottles required for any operation depends upon circumstances. Suppose it be desired to impregnate water with carbonic acid gas; a retort or other vessel, in which the gas is

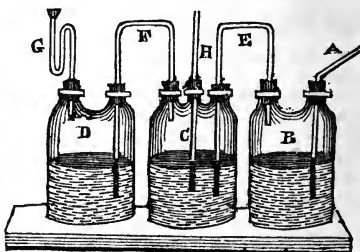

generated, is attached to B by the pipe A, which, as well as all the other pipes, fits through a cork. The gas passes into the water with which B is filled; a part is absorbed, the rest escapes through E. It passes into C, where another portion is retained. The rest flies from F into D, where a third absorption takes place. It might thus be continued along any series of bottles. G and H are safety tubes, (see *Tube*,) which are useful in preventing accident during any operation.

WREATHED COLUMNS. Such columns as are twisted in the form of a screw. They are the sign of a barbarous taste.

WREST, or WRIST. The partitions which determine the form of the bucket in an over-shot wheel

WRITING INK AND FLUID may be of various colors. A good black is, however, the most essential. The following receipts for that and other colors are recommended:—*Black:* For a gallon, take 1 lb. of nut-galls,

bruised; 6 oz. of green vitriol; 6 oz. of gum Senegal, or Arabic; and 1 gallon of water. The galls to be boiled, and then left to settle. The clear liquor to be added to the vitriol and gum. *Japan black ink:* The green vitriol is first calcined; the ink is blacker, but not so durable; more gum is added than to ordinary ink, and sometimes sugar also. *Red ink* is made by boiling Brazil-wood in vinegar or water. Log-wood makes it darker colored. *Yellow, green, blue,* and other colored inks are made by the infusion of gamboge, sap-green, sulphate of indigo, or other pigments. An ink, called *Stephens's writing fluid*, is said to consist of a tannogallate of iron and the sulphate of indigo combined. To make it, boil together nut-galls, indigo, and green vitriol. (See *Ink* and *Vanadium*.)

WROUGHT IRON. Iron which after having been cast in bars, is again heated and hammered, by which it becomes more tough and pliable.



No word, truly English, begins with X; the very few known as terms of science are chiefly confined to natural history, and are derived from the Greek language. X, as an initial letter, and in names, has the sound of z, as in *Xenophon*. When occurring between the other letters of a word, it has a different sound, like that of sk, as in *excuse*; in *Xerxes* both the sounds are contained. X, in the Roman notation, stands for 10; and on account of its cross-like form is used as a contraction for Christ

and cross, as Xmas. for Christmas, Xpher. for Christopher, &c.

XANTHENE. The coloring principle of madder.

XANTHOGENE. A substance composed of carbon and sulphur, which is a base that becomes acidified by hydrogen, called then hydro-xanthic acid; the base is called xanthogene, from the yellow color of its compounds.

XYSTOS. Among the ancient Greeks was a portico of uncommon length, either covered or open, in which the people used to exercise themselves in running races, &c.



Is both a consonant and a vowel; the former at the beginning of words or syllables. It is used instead of i at the end of words, as in *thy*; or when two ii would come together, as in *dying*; and sometimes for the sake of distinction, as in the word *die* and *dye*. In words derived from the Greek, y is made to represent the Greek upsilon, as in *syllable*, *syntax*, &c. Y, in modern contractions, is intended for th., as *ye*, *the*; *yr.*, *your*; *ym.*, *them*, &c.

Y-PIECE. (See *Beighton's Steam Engine*.)

YARN, TWIST, or THREAD. The combination of fibrous materials into a linear form

by torsion. Yarn is more applied to woollen and hempen goods; twist and thread to cotton, linen, and silk.

YEAR. The portion of time occupied by the earth in its revolution around the sun, and in which are comprehended the several changes of the seasons. Various circumstances require that the year should be distinguished by different names and measurements, as follows:—The first is the *astronomical* or *solar* year, or that which is determined by astronomical observations, and is of two kinds, *tropical* and *sidereal*. A *tropical* or *natural solar* year is the time which the sun, or rather the earth, employs in passing through the twelve signs of the zodiac, and which contains 365 d., 5 h., 48', 48".

This is the only natural year, because it always keeps the same seasons in the same months. The *sidereal* or *astral* year is the space of time the sun takes in passing from any fixed star till his return to it again. This consists of 365 d., 6 h., 9', 11", being 20', 29" longer than the tropical year. An *anomalous* year is the interval which is occupied by the earth passing from apogee to apogee; it is greater than the sidereal year, by the time required to describe the annual progression of the apogee. The length of the anomalous year is 365 d., 6 h., 14', 1". *Lunar* year is the space of twelve lunar months. There are two kinds of lunar years. The *astronomical lunar* year consists of twelve lunar synodical months, and contains 354 d., 8 h., 48', 38", and is therefore 10 d., 21 h., 0', 10" shorter than the solar year; a difference which is the foundation of the epoch. The *common lunar* year consists of twelve lunar civil months, and therefore contains 354 days. The *embolismic* or *intercalary lunar* year consists of thirteen lunar civil months, and therefore contains 384 days. The *civil* year is that form of the year which every nation has contrived or adopted for

computing their time by. It is either common or leap year. The *common* year is that consisting of 365 days, having seven months of 31 days each; four of 30 days; and one of 28 days. *Bissexile* or *leap* year contains 366 days, as explained under the word *Leap Year*.

YEAST. The froth arising from any liquid which is passing the vinous fermentation.

YELLOW. The lightest and warmest of the prismatic colors, situated in the solar spectrum, between the red and blue; blending with the former to make orange on the one side, and with the blue to make green on the other. Very numerous pigments of a yellow color are used by the painter—some of vegetable origin, as gamboge, Indian yellow, yellow lake, &c. Others derived from minerals, constituting, in some cases, oxides; in others, metallic salts. Among the former are king's yellow, Naples yellow orpiment, raw Sienna, yellow ochre, &c. Among the latter, the various chrome yellows, mineral yellow, or chloride of lead, iodide of lead, &c.

YTRIA. A rare earth, extracted from the minerals gadolinite and ytrotantalite, being an oxide of the metal yttrium.



No word of Saxon derivation contains this, the last letter of the English alphabet; and the few words we now have beginning with this letter are all derived from other languages, mostly from the Greek. Z has invariably the sound of *s*, but without the hissing that usually attends it; or like the sound of this letter in the word *rosy* and *osier*.

ZAFFRE. The residuum of cobalt, after the sulphur, arsenic, and other volatile matters have been expelled by calcination.

ZEALAND (NEW) FLAX. The fibres of the *Phormium tenax*, a plant of New Zealand.

ZAMBONI'S PERPETUAL MOTION. This is a good electrical apparatus, which acts upon the same principle as Singer's or De Luc's dry pile; the only difference consisting in the form of the instrument, and the material of the small plates. The form is as represented. D is a box containing a drawer: on the centre of the top of the box is a glass pillar, with a steel point at top C; upon this rests a very light frame-work of wire or wood, with six arms at the lower part, upon each of which is suspended a small strip of thin sheet brass or gold. The drawer is filled with several rows of pieces of paper, about an inch square each, altogether about 20,000 in number: one side of the paper is covered with silver leaf, the other

painted over with black oxide of manganese, honey, and water. The papers are arranged so that they should form one continued series throughout. Pieces of tin-foil unite the rows together. One end of this pile is connected with the pole or brass stud A, the other with the contrary pole A. The strips of metal hanging from the cross arms B B, strike one pole and then proceed to the other to deposit the electrical fluid they acquired by

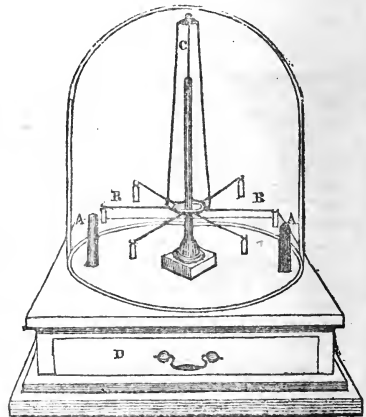

the first impulse. So in the rotation the several strips are in like manner affected, and the frame with its various arms is in continued motion, which it will maintain for years. It is necessary that it should be covered with a glass shade to prevent the disturbance of wind, &c.

ZEINE. A soft, tough, elastic substance, obtainable from maize or Indian corn. It is procured by treating the gluten or starch with alcohol, and evaporating the clear solution.

ZENITH. An Arabic word, used in astronomy to denote the vertical point of the heavens, or the point directly over our heads. It is, of course, the pole of the horizon.

ZENITH DISTANCE. The arc intercepted between any celestial object and the zenith, being the same as the co-altitude of an object.

ZETETIC METHOD. An old term for what we now call analytic method or analysis.

ZIGZAG. An ornament peculiar to Norman architecture. (See *Chevron*.)

ZIMOME. The gluten of wheat, treated with alcohol, and reduced to the third part of its bulk. The result is zimome.

ZINC. A metal of a bluish white color; lustrous when fresh broken, but soon tarnishing in the air. It granulates in irregular crystals, and when cold is brittle, but becomes ductile and malleable at a heat from 220° to 300° Fah., and if then rolled out or hammered it retains its ductility afterwards. It melts at 680°, and with contact of air and a slight increase of heat above this, it burns with a bluish white brilliant light, and becomes converted into a copious white oxyde, called the flowers of zinc. Zinc is soluble in most of the acids. It is used greatly in the manufacture of brass and other alloys; as a material for water cisterns, pipes, baths, plates for doors, and for the zincographer; for voltaic batteries, covering roofs, and numerous other purposes. In commerce it is called spelter.

ZINCODE. The positive pole of a galvanic battery.

ZINCOGRAPHY. The art of drawing upon and printing from zinc. The art, and the whole of the inks and other materials, are precisely similar to those used in lithography, except that, instead of stone, polished sheets of zinc are used; and instead of nitric acid to wash over the drawing, and set in the ink, as in lithography, sulphuric acid is usually employed. Zincography has this advantage, that the sheets of zinc are much less cumbersome and more convenient to use and preserve than blocks of stone.

ZIRCON. The name of a precious stone; called also the hyacinth.

ZIRCONIA. A rare earth, extracted from

the zircon; it is an oxyde of zirconium, a substance possessing, externally, none of the metallic characters, but rather resembling charcoal powder, which burns briskly, and almost with explosive violence.

ZOCLE. A name given to a low, plain, square member, forming the base to a column or obelisk.

ZODIAC. An imaginary ring or broad circle in the heavens, in the form of a belt or girdle, within which the planets all make their excursions; in the very centre of it runs the equator or path of the sun in his apparent annual course. Its breadth is 16°. It cuts the equator obliquely at an angle of 23°, 28', and is divided into twelve signs, each of which contains 30°.

ZODIAC, Signs of the. The twelve constellations which are assigned to or represent the various great divisions of the zodiac. For their names and the symbols by which they are usually expressed, see *Astronomical Symbols*.

ZODIAC OF THE COMETS. A tract in the heavens, which most of the comets, though not all of them, are observed to keep. It is about as broad as the other zodiac, and contains the constellations Antinous, Pegasus, Andromeda, Taurus, Orion, the Lesser Dog, Hydra, Centaur, Scorpion, and Sagittarius.

ZODIACAL LIGHT. A brightness sometimes observed in the zodiac, resembling that of the galaxy or milky way. It appears at certain seasons, namely, towards the end of winter, or in spring. It resembles a pyramid lying lengthwise, with its axis along the zodiac; its base being placed obliquely with respect to the horizon. It is supposed to be an electrical phenomenon, and similar to the aurora borealis.

ZONE. A division of the earth's surface, by means of parallel circles, chiefly with respect to the degree of heat in the different parts of that surface. The zones are five in number: one extending 23°, 28' on each side of the equator, called the torrid zone. Next from the tropic of Cancer in the north, and the tropic of Capricorn in the south to the polar circles, constituted two temperate zones; and the circular spaces within the polar circles completed the number; these are called the north and south frigid zones.

ZOPHORIC COLUMN. Any column supporting the figure of an animal.

ZOPHORUS. The frieze or broad member which separates the cornice and architrave. It was so called by the Greeks, because they adorned it with representations of animals.

ZUMIC ACID. An acid discovered in many acescent vegetable substances; in sour rice; in sour decoction of carrots, pease, &c. It is doubtful if distinct from the acetic acid.

ADDENDA.

ABUTTALS. Boundaries of land.

ANEMONINE. An acrid crystallizable substance, obtained from some species of anemone.

ANTARCTIC. As arctic signifies the north, so antarctic is the south, or those parts of the world opposite to the north. Thus the arctic circle bounds the north frigid zone, and the antarctic circle the south frigid zone; so the south pole of the world is called the antarctic pole, and the watery or icy regions around it the antarctic ocean.

BACK-GROUND. That portion of a picture which is furthest removed from the eye.

BREADTH OF LIGHT. That part of a picture most brilliantly colored, or where the great portion of light is seen to fall. In historical pictures, the greatest breadth of light should fall upon the principal characters, that the eye may have not merely the action and prominent situation of them, but their greater brilliancy to rest upon.

CATCHING LIGHTS. The edges or small parts of objects touched with brilliant colors, to bring them out in relief; for example, the edges of clouds, moon-beams on the water, &c.

CERES. The name given by its discoverer, M. Piazze, to a small planet or asteroid, which circulates between the orbits of Mars and Jupiter. It is of a ruddy color; is surrounded by an extensive and dense atmosphere; and with a telescope having the magnifying power of 200, exhibits a distinct disc. It performs its revolution round the sun in about 4 years, 7 months, and 10 days. Its mean distance from the sun is nearly 2.669 times that of the earth, and its diameter has been variously estimated at from 163 to 1630 miles.

CIRCULAR POLARIZATION OF LIGHT. Certain crystals, particularly rock-crystal, or quartz, have the property of dividing a ray of reflected light transmitted through them, so as to show perfect series of rings around the axis of the crystal; these rings vary with the thickness of the plate of quartz, but they suffer no change by turning the plate round its axis: yet they do become changed when the analyzing plate (see *Polarization*), is turned round from right to left; the red changing successively to orange, yellow, green, and violet.

COLOGNE, or CASSEL EARTH. Two bituminous earths, originating, as it is supposed, from the decomposition of wood. They are used occasionally by the oil painter, as brown for the hair, &c., but are not to be recom-

mended, as they become lighter by time, and dry very slowly.

CONFLICTING LIGHTS IN A PICTURE, are seen when an object is illuminated by two lights at once, as of the sun and of a conflagration, or a torch-bearing procession by moonlight.

CONTRAST. In painting, opposition of two things as to character, whether it be in lines, light, shade, or color.

CONTRACTION. The substitution of part of a word for the whole of it. Contractions are particularly used in mathematics, as *tan.* for tangent; *sec.* for secant; *com.* for compliment; *sup.* for supplement; *ang.* for angle; *sq.* for square; *big.* for biquadrate, &c.: and in chemistry, where the initial letter, sometimes with one or two others added to it, designates all the simple substances, as *o.* for oxygen; *car.* for carbon; *hyd.* for hydrogen; *sulph.* for sulphur, and others.

CUMMING'S MAGNETIC COIL. Contrivances of Professor Cumming to exhibit the polarizing effects of a current of electricity sent through a wire twisted in the form of a flat spiral. There may be several forms. The following are given as examples. The method of suspension and action will be easily understood by reference to the word *Sturgeon*, where similar apparatus is described.

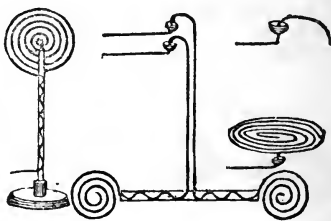

DIRECTORS. Instruments used in medical electricity to rest against that part of the body through which a shock is to be sent. One director being connected to the outside of a Leyden jar by a chain, and another director to the front part of a medical electrometer, the shock will pass along the space



between the ball of one director and the ball of the other, provided it be a conducting substance, like that of the human body. A director is formed of a glass handle, upon which is fitted a cap, furnished with a brass wire and ball.

DOUBLER, Electrical. (See *Condenser*.)

ELIZABETHAN. A peculiar style of architecture used in the age of Queen Elizabeth, and lately coming again into vogue. It may be truly considered as a massive but very inferior style of Gothic. Examples of the peculiar character of the ornamental portion may be seen by reference to the words *Car-touch* and *Scroll*, and the initial letter E.

FIRE-CLOUD. A fountain of compressed air, upon exactly the same principle as the fountain-glass. The vessel contains ether. It is placed in another vessel of hot water; this boils the ether, and drives it up the central jet to a considerable height. When set fire to, the particles of the steam of the ether burn vividly, and represent a complete cloud-shaped mass of flame. The ether may be made to give a red, blue, or other colored flame, according as it is imbued with nitrate of strontian or other ingredient. (See *Fires, Colored*.)

FLEXIBLE TUBE. A tube made of three joints of tin or brass, with a short chain from one to the other, the chain being covered with silk. At one end is a moveable joint, to connect it with the prime conductor of an electrical machine; the other end joint is furnished with a socket in the middle, upon which a director handle may be fixed, and a screw at the end, to connect it to a ball, point, &c. It is for two uses: one to unite the conductor to a stool; the other to direct the spark immediately to any part of the body, the operator holding the glass handle which fits into the appointed socket.

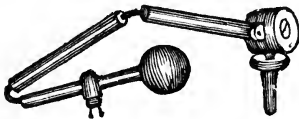

FORCE, Active. Any power which is conducive to motion; the term being used in opposition to *vis inertia*, or resistance.

FOR-GROUND. (See *Distance*.)

GLAIRE. White of egg mixed with water. It is used by the bookbinder to varnish leather bindings, to put a gloss upon kid shoes, &c.; also sometimes by the gilder. Such a varnish will wear well if not wetted.

GLASS CEMENT. Any cement for uniting broken glass; nothing is better than those recommended under the words *Armenian*, *Vancouver*, and *Cheese*. Gum mastic is often used for the same purpose, and answers

well, but will not bear heat. White lead is also employed; it remains firm, but shows a dark mark at the joint.

HERSCHEL. (See *Uranus*.)

HONEY-SUCKLE ORNAMENT. A particular shaped ornament introduced into architectural embellishment by the Greeks, and superseding with them the lotus, so common, and so highly regarded by the Egyptians. The honey-suckle ornament is seen engraved on acroteria; in friezes, external and internal; on vases; in paintings; and embroidery; in carvings and metal castings; in a thousand varied forms—all combining the most elegant combinations of beautiful curves, as witnessed in the following sketch:—

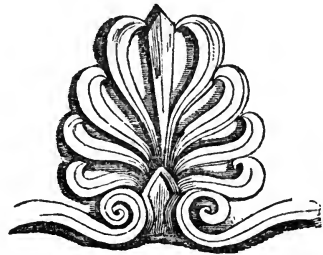

INSULATE. A term of electricity, signifying to separate from the earth and all other conducting substances, so that the electrical impulse given to a body may remain with it, and the fluid not be carried off by contact with surrounding bodies.

IRON CEMENT. A cement for uniting together, or rather assisting in uniting together pieces of iron, such as the joints of steam boilers, stoves, pipes, &c., so as to prevent leakage. It is made as follows:—Pound together, in a mortar, 2 oz. of sal ammoniac, 1 oz. of sulphur, and 5 lbs. of iron filings. This will become as hard as iron itself in a few days.

ISOCHRONOUS. (See *Synchronous*.)

ISOCHRONISM. The property of being isochronous.

LAPIDARY CEMENT. Gum mastic is used to fasten gems into their settings, the gum being melted by heat. For larger articles, and also for fixing the stones when they are being cut or engraved, bees'-wax 1 part; yellow rosin 2 parts; and plaster of Paris sufficient to bind it together, and make it white, is mostly employed.

LETTER BALANCE. Since post letters have been charged by weight, numberless small and elegant table balances have been constructed; to specify even a few of them would be tedious. The following is one of the neatest. The letter brings up the counterpoise, weighing down its own side of the

scale at the same time, and bringing the hand to a certain part of the graduated arc at top, according as the weight of the letter may be, 1, 2, 3, or 4 ounces, or any intermediate portion of them.

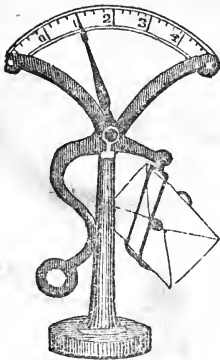

MAGDEBURG HEMISPHERES. An apparatus used with the air-pump, and intended to prove the weight of the atmosphere. It consists of two hemispherical metallic cups, having their rim widened out and ground, so, that with a little grease between, the cups fit each other air-tight. The upper cup has a handle attached: the lower cup is perforated at bottom, and affixed to a stop-cock, which screws to a stand when not in use, and to the plate of the air-pump when wanted. To show the weight of the atmosphere, attach the lower cup to the pump plate, carefully rest the upper cup upon it, turn the cock on, (as drawn,) and exhaust the air as much as possible from within; then turn the cock off, remove the apparatus from the pump, and screw a second handle on to the end of the cock. Two persons pulling one at each end will most probably not separate the cups; the strength to do which will be 15 lbs. multiplied by the area of the cups.



MARINE BAROMETER. The barometer constructed in the usual way would evidently be useless on board a ship at sea, as the pitching and rolling of the vessel would keep the mercury in a state of perpetual oscillation. This inconvenience has been overcome by making the greater portion of the tube of very narrow bore, but terminated by a cylindrical portion of a larger size, about $\frac{3}{10}$ of an inch in diameter; the instrument is suspended by a spring and gimbals, at a point near

the top, which is found in each case by trial.

MERCURIAL GAUGE. (See *Siphon Gauge*.)

MERCURIAL PENDULUM. This pendulum, instead of a weight or bob, has a tube partly filled with mercury. The object is, that the heat of the air which would elongate the pendulum bar may be counteracted by its effect upon the tube of mercury; for, as the metal rod and the mercury are both affected by the same cause, the one will counteract the other; the elongation of the rod is downwards, making the pendulum longer; the elongation of the mercury is upwards, like in a thermometer tube, and consequently making it shorter: the centre of gravity of the whole, therefore, remains the same, and the pendulum is of a true length at all times and in all circumstances.

MESSO-RELIEF. Carvings and castings of such a nature, that the figures or ornaments are neither very prominent, as in alto-relief; nor depressed, as in bass-relief.

METALLIC INK, GOLD INK, SILVER INK, &c. These inks are made by grinding gold leaf, silver leaf, or laminae of any other metal with honey, until it forms a uniform paste; the honey is then washed away with water, and the residuum dried. It is now known as bronze powder. To reduce it to the state of ink it must be mixed with weak gum-water.

MID-DISTANCE. (See *Distance*.)

MOUNTAIN BAROMETER. A form given to the ordinary barometer, to render it portable and convenient for travellers, in ascertaining the height of mountains, &c. In the brass box A, which covers the cistern of mercury, are two slits made horizontally, precisely similar, and opposite to each other; these represent the zero or beginning of the scale of inches. The screw B performs a

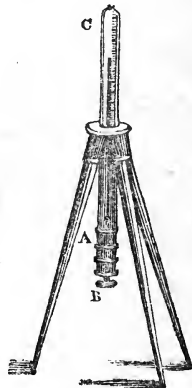

double office; first, it is the means of adjusting the surface of the mercury in the glass cistern to zero; secondly, by screwing it

entirely up it incloses all the mercury in the tube, and thus prevents waste in carrying the instrument. By the help of a vernier, the scale of the upper part is divided to the five hundredth of an inch. The screw C, at the top, moves a sliding piece, on which the vernier scale is divided. The barometer is attached to the stand by a ring, in which it turns round with a smooth and steady motion, for the purpose of placing it in the best light for reading off, &c.; and the tripod stand, when closed, forms a convenient packing-case for the instrument.

NEUTRAL TINT. Grey is called by way of eminence the neutral tint, being the mean between black and white. It is made by mixing together a transparent red, blue, and yellow; or else either two of the secondary colors, purple and green; or green and orange.

OIL COLOR PRINTING. Every kind of printing with ink may truly have this name; but it particularly applies to an invention of Mr. Baxter, of Charter House Square, London, whereby the depth and brilliancy of an oil painting is produced by the whole of the colors being laid on and blended together by the operation of the printer's press; the ground-work upon which they are laid being an engraving on metal or wood, and printed in black, neutral tint, or other color, according to the effect ultimately to be produced. For each color afterwards to be laid on, a separate wood-cut is so prepared, that it exactly covers an appointed part of the picture, the edges of the wood-cut being left shrap, if the color is to end in an abrupt line, or hollowed out, or sloped away more or less, where the color is to be gradually softened off. The whole of the wood-blocks, (sometimes thirty in number,) being prepared, a peculiar ink, tinted with the requisite color is taken, and by means of small balls is dabbed upon the block of wood first to be used. The print, by a very nice adjustment with the points of needles, is placed upon the block, and which is already laid upon the table of a printing press, and being passed through the press, the color from the wooden block is impressed upon the print: it is then printed upon in like manner by a second block of wood; afterwards in regular order by all the rest, until the whole is complete, the picture then assuming the utmost delicacy and power. The fine painted prints of the Death of Mr. Williams, and the Coronation of Her Majesty, by this artist, show strongly the capacity and beauty of the result of the art.

ORIENTAL TINTING. (See *Stencil*.)

PALMER'S BLOW-PIPE JET. When it is desired to burn the mixed gases, oxygen and hydrogen, it is desirable that the jet should be so constructed, that they may be united previously to being inflamed, and that they

shall not return through the jet into the reservoirs. To avoid the danger which would accrue from this accident, the gases should be kept in separate vessels till wanted. Mr. Palmer's safety jet is well adapted to meet these various contingencies. It is shown in section beneath. The stand may be used or not, as found most convenient, it forming no part of the contrivance; which consists of two tubes E E, fitted at the outward ends with screws adapted to stop-cock or gas receivers. The end A being connected with the receiver for hydrogen, and the end B with that containing oxygen, the cocks of the respective bladders being turned on, the gases pass through the separate tubes into the chamber, which is filled with the finest wire gauze; in filtering through this, the gases become perfectly mingled; they then pass on to the jet, which is secured to the hole D. At E E are two conical valves opening inwards, which allow a free passage for the gases passing in the direction of the arrows, but which, from the nicety of their construction, instantly close if there is any pressure in the opposite direction.

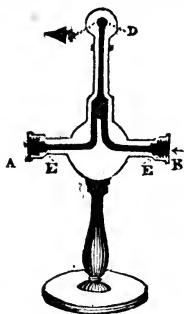

PICKING IN. In painting, the restoring of any accidental unevenness or inequality in a tint in a picture, by neatly and carefully covering the unseemly or deficient spots with a small pencil, and with a tint accurately prepared to match with the parts to be picked in.

PRINTER'S MORDANT. Acetate of alumina, used by the calico printers. (See *Mordant*.)

RACEMIC ACID. A curious modification of tartaric acid, termed, by Berzelius, *paratartaric acid*, otherwise called racemic acid, under the supposition that it is peculiar to certain kinds of grapes. It is less soluble than tartaric acid, and contains twice as much water of crystallization. It is obtained by neutralizing the tartar which contains it with soda, and separating the double tartrate of soda and potassa by crystallization. "The double *racemate* remains in the mother liquor, which, filtered through animal charcoal, and decomposed by a solution of acetate of lead,

yields a mixed tartrate and racemate of lead; these diffused through water, and decomposed by sulphuretted hydrogen, furnish a solution of racemic and tartaric acid, from which the former may be perfectly separated by crystallization, while the latter remains in the mother liquor."—*Brande*.

REFLECTED LIGHTS. Lights which fall on the shaded sides of objects, by being reflected from water or the like.

RETORT STAND. Any stand used to support a retort. Retort stands usually consist of a solid foot, which supports an upright rod of metal, upon which are fitted three slides, adjustable to any height which may be required by screws; each slide bears a ring of wire, upon which the bottom or neck of the retort rests; the rings being of different sizes to suit various apparatus.

RICE CEMENT. A kind of paste used in different degrees of hardness, according to the purpose for which it is required. It may be made thin, like the ordinary paper paste, or of nearly a solid consistence; in the latter case, it is used especially among the Chinese in moulding various ornaments, which, when dry, have much the appearance of ivory. The thinner kind is for the ordinary purpose of common paste, to which it is superior for some delicate purposes, in being more transparent. In making it, rice and flour must be used, (not ground rice,) and this boiled for some time.

RITCHIE'S AIR-PUMP. A contrivance of the late Mr. Ritchie, whereby the use of valves, which are always troublesome in pneumatic apparatus, is avoided; besides which, this air-pump is very simple in formation and easily worked. The stand, receiver, pump-plate, &c. are the same as in the ordinary air-pump. The barrel A is the only difference. This (see the cut,) proceeds below the tube leading to the receiver. The piston is quite solid, and works through an air-tight collar at top; also near the top of the barrel is a small hole or tube D, which

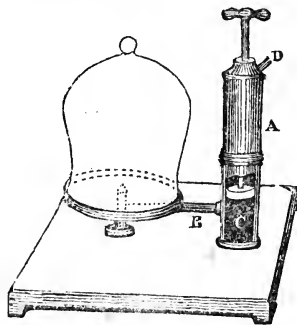

may be closed by the finger. Upon driving down the piston to its utmost extent, air

will occupy the upper part of the barrel. Upon drawing up the piston, the air contained in the barrel itself will escape by the hole D. When the piston is arrived at the top, the hole is closed by the finger, and the piston thrust down again to C, or below the orifice of the tube B. The barrel is therefore filled with air from the receiver a second time, which is removed in like manner, and so on as long as may be required to empty the receiver.

SCINTILLATION. A burning away in brilliant sparks, as is seen when tools are ground on a dry stone; when charcoal is burned in oxygen gas, or when certain fire-works are set light to.

SCRAPING. An operation whereby a peculiar kind of roughness or frothiness is given to water color drawings, so as to imitate what is commonly called a *mackerel sky*; and still more especially to give the effect of splashing water, as the surf of the sea, the breaking of the waves, &c. The picture is completely colored with its proper tints; then the artist takes a pen-knife, sharp towards the point, and scrapes out the color, holding the knife firmly or loosely, according to the effect desired. If the light of moon-beams on a smooth lake be wished for, the knife may be held tightly in the hand; but if to imitate beating or rippling water, falling snow, &c., the knife should be held very loosely, near the end of the handle, and the point of it be allowed to jump along; thus taking out specks of color only.

SCREEN, Magic Lantern. A medium upon which are thrown the figures exhibited by the magic lantern, phantasmagoria, &c. For ordinary purposes of the magic lantern a common sheet, pinned tightly against a wall, at 10 or 12 feet distance from the lantern, is employed. For the phantasmagoria the screen must be transparent, because the figures are to be seen through it; for such a screen as this nothing is better than common tissue paper, stretched on a frame; it may be oiled or not, according to the pleasure of the operator, or be rubbed over with turpentine and bees-wax, so much turpentine being used that the mixture is quite soft. For theatrical exhibitions of this kind, where greater strength is requisite, fine thin muslin is used. It is joined so as to show the seams as little as possible, stretched on a frame or fastened to rollers, and washed over with white wax and turpentine, transparent varnish and turpentine, or Canada balsam and turpentine. For the oxy-hydrogen microscope a different screen is necessary. The objects are thrown, as in the ordinary lantern, upon a wall, but a sheet pinned up will scarcely offer a surface sufficiently smooth; therefore for purposes of public exhibition at least, the wall itself

is made perfectly smooth and white, or else the screen is made of stiff and wide cloth, covered with paper, and then painted of a pure white color.

SHARPIN'S HYDRAULIC BLOW-PIPE. A. in the figure, is a cylindrical tin vessel, 13 inches deep and 10 inches in diameter. B is a loose lid, to which is soldered airtight the vessel C, which is $6\frac{1}{2}$ inches in diameter, but without a bottom, and approaches to within a quarter of an inch of the bottom of the former vessel A. D is a piece of $\frac{1}{4}$ -inch lead pipe, with a tap at the lower end, which communicates with the interior of the vessel C. E is a piece of $\frac{1}{2}$ -inch pipe, which also communicates with the vessel C. F is the lamp. G G are two pins of wire, to prevent the lid from being lifted up by the pressure of the water when in action. I is a lip, which must be left uncovered, so as to allow the air free access to the space between the vessels A and B.

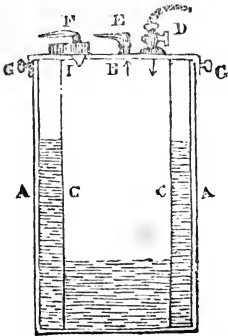

To use the blow-pipe, take off the lid, and nearly half fill the vessel A with water; then put on the lid, and fasten it down by the wire pins G G. Put a glass nozzle on the pipe E; open the tap, and blow down the pipe D, so as to force all the water out of the vessel C. Then shut the tap, and you will have a steady stream of air for about three minutes, providing the orifice in the glass nozzle be not too large.

SLIDER. Any thing which slides, particularly those oblong pieces of glass, inclosed in a wooden frame and covered with painted devices, which are illuminated and magnified by the magic lanthorn, phantasmagoria, &c. The difference between the sliders fit for the two instruments consists in the general ground of those used with the magic lanthorn being left uncolored, and those of the phantasmagoria being blackened. The size of the slider must, of course, be accordant to the size of the lanthorn with which it is to be used. It may be of a fixed unchangeable

device, as the picture of a ship in full sail; or it may change, and assume a different aspect, as the ship on fire; or, thirdly, one portion may be fixed, and figures move across it. The first effect is produced by a mere painting on the glass. Changes may be given by two or more glasses being inserted in the same frame; all but one glass being moveable either sideways or up and down. Upon these other glasses the second parts of the picture, for instance, the flames of the ship, or the moving objects are to be depicted. *To paint the sliders:*—Draw the design on a piece of paper; lay it under the glass, sketch the outline with a fine brush, dipped in very dark color, mixed with varnish, and afterwards fill up the outlines with the various colors requisite. These must be all transparent, such as are recommended for transparent painting, mixed with mastic or other colorless varnish. (See *Transparent and Glass Painting.*)

SFLTER. A common name among founders, and others, for metallic zinc.

SPOTTINESS IN A PICTURE. A part or parts either of light or of dark, too conspicuous to agree with the situation in the scene. The correction of such spottiness is necessary to the preservation of keeping.

TEINOSCOPE. By combining a concave lens of a substance, having a higher dispersive power than the convex object glass of the achromatic telescope, its color may be corrected without destroying the whole of the refraction produced by it. From numerous experiments made by Dr. Brewster, to determine the inequality of the length of the different colored spaces in spectra of equal lengths, he found that the least and most refrangible colors might be destroyed, and refraction produced when he employed two prisms of the same substance, provided that the prism, with the least refractive angle, was inclined so that the incident rays entered obliquely, by which means the dispersion is increased in a greater ratio than the refraction. From this very curious circumstance of producing refraction without color by two prisms of the same substance, Dr. Brewster has proposed that opera glasses should be constructed, and to which the name of teinoscope has been given.

TILLEY'S HYDRAULIC BLOW-PIPE. The structure of this instrument, and which was invented previously to that of Mr. Sharpin's, (see *Sharpin*,) is very similar to it.

A is the outer vessel, which is square. B a division across it. D a pipe fitted with a cock that may be turned off, or a valve inside, which opens downwards. E is the jet, through which issues the blast of air, or oxygen, supposing such supplied to the instrument previously. F the lamp. To use the instrument, blow strongly into D,

the jet E being either furnished with a cock, or made so that when it is partly turned

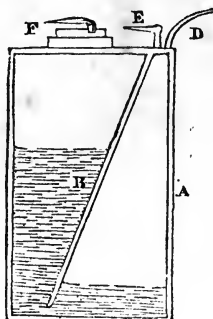

the water, drive it into A, and expel the air in A, through the jet, producing what is required, namely, a strong and regular blast.

TONE OF A PICTURE. The general effect or appearance of the coloring.

WOLLASTON'S STEAM APPARATUS. Such is the somewhat indefinite name given to a small but neat contrivance of Dr. Wollaston, to illustrate the principle of the condensing steam engine. It is represented annexed, and consists of a glass flask fitted with a belt outside, and handle screwed to the belt. Inside it has a solid piston working with little friction, yet steam-tight, up and down. A little water or ether is placed in the bulb of the flask and made to boil; the piston is then put in, and the bulb being dipped for a moment in cold water, the steam within condenses, and the piston descends; making the liquid boil a second time drives up the piston, &c.; thus the piston rises at every formation, and falls at every condensation of the steam



round, it may shut off the communication with the inside of A. A will become filled with the air from the lungs, and drive the water into B, compressing the air above it. When the operator ceases to blow, and the jet E is turned towards the flame, the elasticity of the air in B will press upon the surface of

ERRATA AND NOTICES.

FRACTION. In the explanation of this word, reverse the position of the words "numerator" and "denominator."

SAIL, or WHIP. After "miles" insert "per hour."

SILVERING GLASS GLOBES. For "1 part by weight of lead, $\frac{1}{2}$ part of lead, &c.;" read "1 part by weight of bismuth, $\frac{1}{2}$ part of lead, &c."

The words CARBAZOTIC ACID, CRAEKER, and one or two more words are accidentally misplaced. A few others are necessarily so, because of the cuts accompanying them.

Note.—AGRICULTURAL AND GARDENING INSTRUMENTS, although first intended to be introduced, were afterwards purposely omitted, as the space they would have occupied would have been considerable.

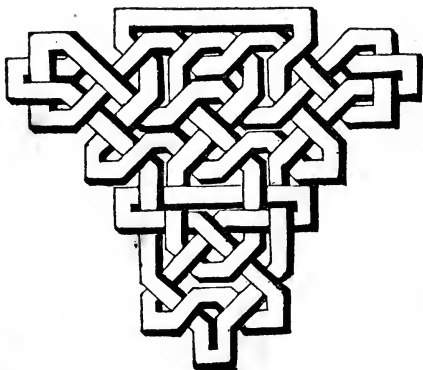

M-2

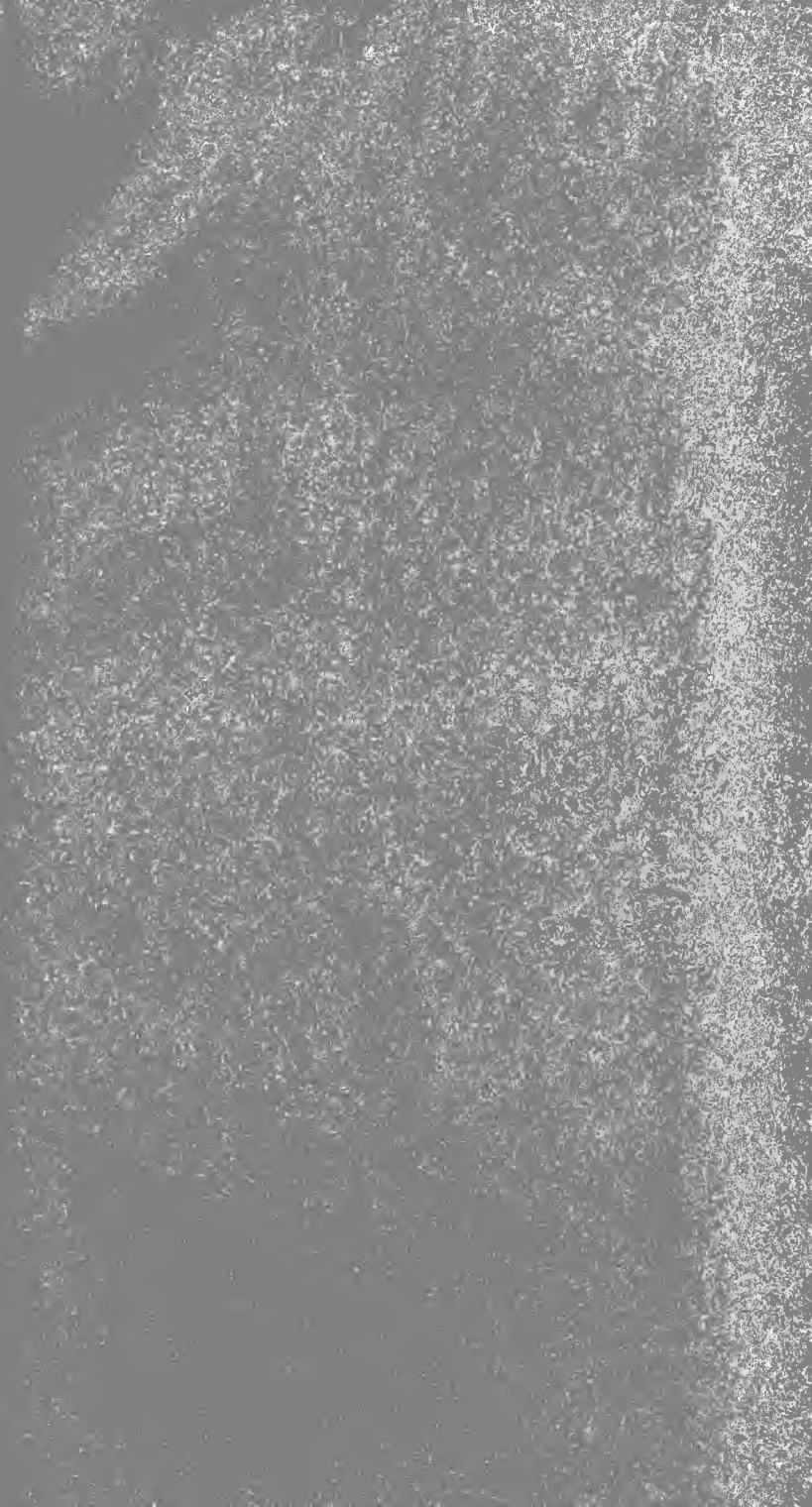

**THIS BOOK IS DUE ON THE LAST DATE
STAMPED BELOW**

**RENEWED BOOKS ARE SUBJECT TO IMMEDIATE
RECALL**

LIBRARY, UNIVERSITY OF CALIFORNIA, DAVIS

Book Slip-50m-12,'64 (F772s4)458

361830

Francis, G.W.

Dictionary of the
arts, sciences and
manufactures.

T9
F81

LIBRARY
UNIVERSITY OF CALIFORNIA
DAVIS

