



LIBRARY  
OF THE  
UNIVERSITY OF CALIFORNIA.

*Class*





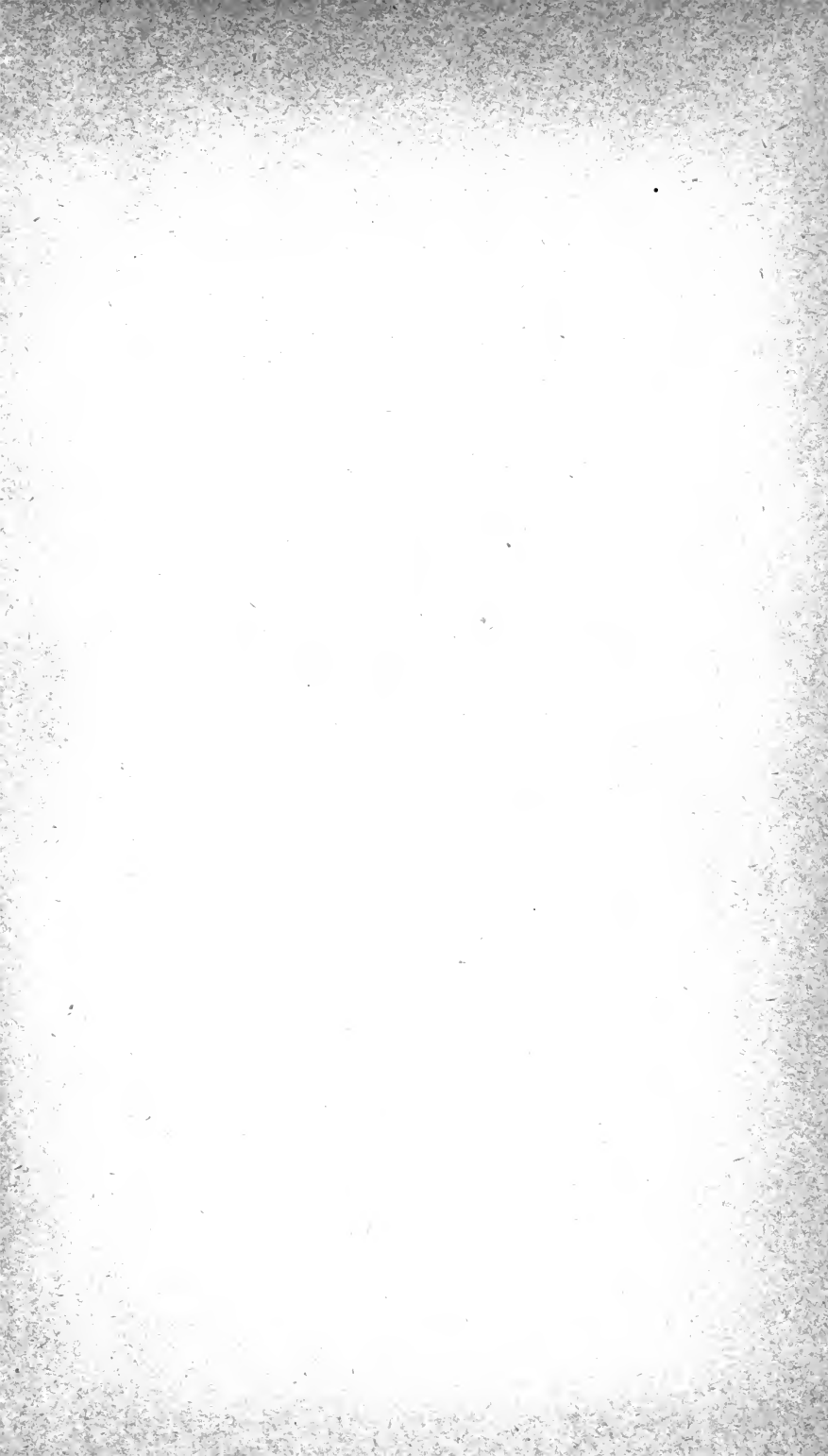



DOMESTIC  
SANITARY DRAINAGE AND PLUMBING

## **WORKS ON SANITARY ENGINEERING.**

**VENTILATION AND HEATING.** By JOHN S. BILLINGS, A.M., M.D., LL. D., Edinburgh and Harvard; D.C.L., Oxford. With Diagrams. Demy 8vo. 25s. net.

**WATER WORKS FOR SMALL CITIES AND TOWNS.** By JOHN GOODELL. Demy 8vo. 10s. net.

**METHODS OF PRACTICAL HYGIENE.** By K. B. LEHMANN. Translated by W. CROOKES. Two Vols. Demy 8vo. £1 11s. 6d.



## **PROFESSOR WANKLYN'S WORKS.**

**MILK ANALYSIS:** A Practical Treatise on the Examination of Milk and its Derivatives—Cream, Butter, and Cheese. By J. A. WANKLYN. Second Edition. Cr. 8vo. 5s.

**WATER ANALYSIS:** A Treatise on the Examination of Potable Water. By J. A. WANKLYN and E. T. CHAPMAN. Eighth Edition, entirely rewritten. Cr. 8vo. 5s.

**BREAD ANALYSIS:** A Practical Treatise on the Examination of Flour and Bread. By J. A. WANKLYN and W. J. COOPER. Cr. 8vo. 5s.

**AIR ANALYSIS:** A Practical Treatise. With Appendix on Illuminating Gas. By J. A. WANKLYN and W. J. COOPER. Cr. 8vo. 5s.

**SEWAGE ANALYSIS:** A Practical Treatise on the Examination of Sewage and Effluents from Sewage. By J. A. WANKLYN and W. J. COOPER. Cr. 8vo. 7s. 6d.

---

LONDON: KEGAN PAUL, TRENCH, TRÜBNER & CO., LTD.



DOMESTIC  
SANITARY DRAINAGE AND PLUMBING

LECTURES  
ON  
PRACTICAL SANITATION

DELIVERED TO  
PLUMBERS, ENGINEERS, AND OTHERS

IN  
*THE CENTRAL TECHNICAL INSTITUTION*  
*SOUTH KENSINGTON, LONDON*

UNDER THE AUSPICES OF  
THE CITY AND GUILDS OF LONDON INSTITUTE FOR THE  
ADVANCEMENT OF TECHNICAL EDUCATION

BY  
WILLIAM R. MAGUIRE  
(OF DUBLIN)

ASSOCIATE OF THE INSTITUTION OF CIVIL ENGINEERS OF IRELAND; REGISTERED TEACHER OF  
PLUMBING, CITY AND GUILDS OF LONDON INSTITUTE; REGISTERED MASTER PLUMBER  
WORSHIPFUL PLUMBERS' COMPANY, LONDON; CERTIFICATED SURVEYOR OF THE  
SANITARY INSTITUTE OF GREAT BRITAIN

FOURTH EDITION  
(REVISED AND BROUGHT UP TO DATE)



LONDON  
KEGAN PAUL, TRENCH, TRÜBNER & CO., LTD.  
PATERNOSTER HOUSE, CHARING CROSS ROAD

1903

FILED  
MAR  
1903

FEDERAL

*(The rights of translation and of reproduction are reserved.)*

# CONTENTS.



## CHAPTER I.

	PAGE
INTRODUCTION . . . . .	1

## CHAPTER II.

THE EDUCATION OF PLUMBERS . . . . .	9
-------------------------------------	---

## CHAPTER III.

ELEMENTARY SCIENCE FOR PLUMBERS . . . . .	22
---	----

## CHAPTER IV.

SEWAGE DISPOSAL . . . . .	101
---------------------------	-----

## CHAPTER V.

SEWERAGE AND DRAINAGE . . . . .	126
---------------------------------	-----

## CHAPTER VI.

SANITARY PLUMBING . . . . .	202
-----------------------------	-----

## CHAPTER VII.

SANITARY APPLIANCES . . . . .	230
-------------------------------	-----

## CHAPTER VIII.

WATER SUPPLY . . . . .	367
------------------------	-----

## CHAPTER IX.

HOT-WATER SUPPLY . . . . .	417
----------------------------	-----

## CHAPTER X.

PLUMBERS' MATERIALS . . . . .	448
-------------------------------	-----

## CHAPTER XI.

PLUMBERS' TOOLS . . . . .	471
---------------------------	-----

## CHAPTER XII.

PLUMBERS' RULES AND TABLES . . . . .	482
--------------------------------------	-----

INDEX . . . . .	499
-----------------	-----





# DOMESTIC SANITARY DRAINAGE AND PLUMBING.



## CHAPTER I.

### INTRODUCTION.

THE City and Guilds of London Institute for the Advancement of Technical Education, acting in conjunction with the Worshipful Company of Plumbers, London, arranged for the delivery of courses of lectures to technical teachers of plumbing, journeymen plumbers, apprentices, and others, at the Central Technical Institute, Exhibition Road, South Kensington, on the subject of Domestic Sanitary Drainage and Plumbing. These lectures are published with the object of extending the sphere, and of promoting in some degree the ultimate success of the efforts made by the Institute to advance the technical education of plumbers.

These pages are arranged with the special intention of enabling plumbers to obtain a more intelligent grasp of the questions which they may be called on to solve at technological examinations in plumbing, and which they must inevitably face in daily practice. The author hopes, from forty years' practical experience, not only to provide useful instruction for plumbers in the theory and practice of their craft, but also to give to architects, engineers, and

others in professional contact with the craft, a wider and deeper appreciation of the importance of domestic sanitary drainage and plumbing, and to induce the public to consider and understand more fully the intimate relation existing between sanitary plumbing and public health.

Various causes have combined to lower the dignity of the plumber's craft in public estimation, but in recent years the vital importance of sanitary plumbing and drainage has been admitted, and a desire has arisen among masters and artisans to elevate and improve the craft, which it is the object of this work to stimulate and strengthen. Dr. Pridgin Teale, of Leeds, has rendered good service to the public by stating boldly his opinion: "One-third at least of the incidental illnesses in the kingdom are the direct result of drainage defects, and therefore can be, and ought to be, prevented."

The truth of that important statement is attested by the experience of the author, who, in the course of over 3,000 sanitary surveys of dwelling-houses, from 1860 to 1890, was forced by the facts disclosed to furnish reports condemning 99 per 100. Out of 3,000 houses, 30 were in a sound sanitary condition, 2,970 were dangerous to the health of the residents owing to defective plumbing and drainage.

Plumbing, or the art of casting and working in lead, claims a great antiquity. Lead undoubtedly was worked contemporaneously with silver, and is referred to in the oldest known writing, the Book of Job, as existing four thousand years ago, in patriarchal times—

" Oh that my words were now written !  
 Oh that they were inscribed in a book !  
 That with an iron pen and *lead*  
 They were graven in the rock for ever !"

Italian plumbers wrought so nobly two thousand years ago that their lead-work remains to-day in the excavations

of Rome, Pompeii, London, Bath, and York, as worthy monuments of the ancient dignity of the art.

Five hundred years ago English plumbing had been well established, for we find in 1365 an ordinance of King Edward III., followed by others of Henry VII., Henry VIII., and Elizabeth, conferring privileges and legislating for the protection of the mutual interests of the public and of the craft.

If the dignity of the craft, founded on so ancient and honourable a basis in the memory of past ages, is to be once again upheld, it must be restored and maintained by the honest determination of modern plumbers to emulate their ancestors in good work, and by honourable labour to excel them, if they can, both in knowledge and in skill.

Each and every member of the plumbing craft, whether employer, foreman, journeyman, or apprentice, should seek to gain increased knowledge and experience in the science underlying his practice.

The stimulating encouragement and the fostering care displayed towards the plumbing craft throughout this kingdom by the City and Guilds of London Institute, in conjunction with the London Guild of Plumbers, deserve to be remembered with respect, and to be taken full advantage of with energy and perseverance.

Many of the City of London Guilds, which in olden times represented and controlled particular trades, are now only nominally connected with them, but the Worshipful Guild of Plumbers claims to be closely identified with the interests of the craft—many practical plumbers are livery-men of the company—so that it forms a rallying-point round which the trade can assemble for counsel and strength in difficulty or trouble.

The Plumbers' Company traces back its ordinances to the fourteenth century, and as the history of plumbing should

#### 4 DOMESTIC SANITARY DRAINAGE AND PLUMBING.

form a part of the technical education of plumbers, for the purpose of inciting students to attain excellence in their handicraft, the translation of these ancient ordinances from the Norman-French language used at that time is here given as recently republished by the Plumbers' Company:—

38 *Edward III.*, A.D. 1365. *Letter Book E.* (*Norman-French.*)

“May it please the honourable men and wise, the Mayor, Recorder, and Aldermen of the City of London, to grant unto the Plumbers of the same City the points that here follow:—

“In the first place, that no one of the trade of Plumbers shall meddle with works touching such trade within the said City, or take house or apprentices, or other workmen, in the same, if he be not free of the City; and that, by assent of the best and most skilled men in the said trade, testifying that he knows how well and lawfully to work, and to do his work; that so the said trade may not be scandalised, or the commonalty damaged and deceived, by folks who do not know their trade.

“Also that no one of the said trade shall take an apprentice for less than seven years; and that he shall have him enrolled within the first year, and at the end of his term shall make him take up his freedom, according to the usage of the said City.

“Also, that every one of the trade shall do his work well and lawfully, and shall use lawful weights, as well in selling as in buying, without any deceit or evil intent against any one; and that for working a clove of lead for gutters, or for roofs of houses, he shall only take one half-penny; and for working a clove for furnaces, *tappetroghes*, belfreys, and conduit pipes, one penny; and for the waste



of a wey of lead when newly molten [he shall have an allowance of two cloves], as has been the usage heretofore.

“Also, that no one for singular profit shall engross lead coming to the said City for sale, to the damage of the commonalty; but that all persons of the said trade, as well poor as rich, who may wish, shall be partners therein at their desire. And that no one, himself or by another, shall buy old lead that is on sale, or shall be, within the said City or without, to sell it again to the folks of the same trade, and enhance the price of lead, to the damage of the commonalty.

“Also, that no one of the said trade shall buy stripped lead of the assistants to tilers, *lagers*, or masons, or of women who cannot find warranty for the same. And if any shall do so, himself or by his servants, or if any one of them be found stealing lead, tin, or nails, in the place where he works, he shall be ousted from the said trade for ever, at the will and ordinance of the good folks of such trade.

“Also, that no one of the said trade shall oust another from his work undertaken or begun, or shall take away his customers or his employers to his damage, by enticement through carpenters, masons, tilers, or other persons, as he would answer for the damage so inflicted, by good consideration of the masters of the said trade.

“And if any one shall be found guilty under any one of the articles aforesaid, let him pay to the Chamber of the Guildhall, in London, for the first offence, 40 pence; for the second, half a mark; for the third, 20 shillings; and for the fourth, 10 pounds, or else forswear the trade.”

Plumbers have nothing to gain by denying that their craft has in some points fallen away since those ancient ordinances were in force, but they may admit the fact with courage and hope, because they have determined to do all in their power to remedy shortcomings, and, by employing

the lever of united effort and using as a willing fulcrum the Guild of Plumbers, they may hope, like Archimedes, to move the world.

In order that all plumbers may be strong and of good courage, it is well to realise that by the revived trade action of the Plumbers' Guild they have now an acknowledged head to a body of united craftsmen. The Plumbers' Company, in 1885, promoted and presided over a National Congress of Plumbers, when the status and condition of the plumbing craft was duly considered, together with the various means suggested for remedying abuses and elevating the craft, both in the interest of the plumbers themselves and of the public. The Court of the Plumbers' Guild seconded and supported every effort made. The Congress was unanimous in requesting the Plumbers' Company to take all necessary action for carrying the movement to a successful issue, acknowledging the Plumbers' Company as the proper head of the trade, and formally charging upon the Plumbers' Guild the responsibility of the guardianship of the craft.

The following resolutions were adopted:—

“1. That experience points to the necessity for more closely particularising plumbing and draining work in agreements and specifications for buildings, treating such work in all cases as a separate item, in order that plumbers may be directly responsible for the quality of their work.

“2. That an extension of the existing system of technical instruction for plumbers is necessary, in order to compensate for the unsatisfactory apprenticeship now prevalent.

“3. That a system of registration of qualified plumbers, masters and journeymen, should be established.

“4. That a generally acceptable standard of quality for plumbers' materials should be fixed.

“5. That all plumbing and draining work in new build-

ings should be approved by a suitable local authority and inspected under Building Acts and by-laws."

As the measures of reform thus recommended might affect public regulations and various existing interests, a representative Standing Council was elected, representative not only of plumbers, but of the building and other associated trades, and also of architects, engineers, and other professions immediately connected with plumbing, and this Council has since succeeded in carrying many of the resolutions of the Congress, especially the national registration of plumbers, into practical effect.

All who are plumbers, or who desire to become plumbers, should aspire to a thorough knowledge of the craft; not merely to be able to wipe a solder joint—which, by the way, many plumbers are not able to do well—but to be competent to do all that a modern sanitary plumber ought to do, to know all that a modern sanitary plumber ought to know.

There is a certain dignity in the plumber's trade. In that trade there is scope for highly intelligent skill and for manly character. The power of the arms and hands, the power of the mind and will, and the power of conscience may all be called into active service; and as each power grows stronger by exercise the more ennobled is the work done, and also the artisan who does it.

Every journeyman plumber should seek to perfect his skill in the handicraft of plumbing and his knowledge of the art and science of plumbing; he should also be, in his conduct and principles, a conscientious man, with whom every one of any rank can deal, as respectable and honest men can deal with one another, in mutual respect and mutual confidence.

A brotherly, helpful feeling should also be cultivated. The plumber's craft should be a brotherhood, in which every member should be ready to share his knowledge, experience,

and skill with brother craftsmen, to the end that enlarged powers and extended knowledge may ennoble the craft, and raise it on a pedestal above other trades which demand only the strong muscles of a labourer's arm.

There is a theory and practice in existence in the trade which tends to degrade the plumber's handicraft. It is that false system which aims at securing for every workman, without regard to his industrial, mental, and moral powers, one standard of status and of payment. If any artisan's labour is worth high wages, he should receive the full value of his labour; if his labour is not worth high wages, he should not be allowed to claim more than his labour is worth. Any system demanding equal pay for unequal work destroys in the artisans all desire for improvement, all individual effort and responsibility, and turns the men who submit to its tyranny into menial servants and mere machines, without mind, without energy, and without ambition for higher and nobler things.

Such trade prejudices should not be tolerated in the plumber's craft. It claims from every member a hearty determination to maintain its dignity in all his doings, and then the world will readily yield the respect which we claim as our right.

Some old-fashioned persons hold the doctrine that plumbers should be required to confine their energies strictly to plumbing or lead-work, but the young men in the trade of the present day will seldom refuse an order for a kitchen range, or a fire-grate, or a mantelpiece if they can secure it from the householders they are employed by; and so, in like manner, plumbers have had to submit, with the best grace they can, when merchants and manufacturers in other trades than plumbing have rivalled and out-distanced them in their own plumbing trade by greater energy, wider knowledge, and changing customs.

## CHAPTER II.

### THE EDUCATION OF PLUMBERS.

THE education, or the drawing out of the powers of plumbers, has been, in common with that of other trades, sadly neglected; the preparation of the ground for cultivation, and the kind of seed sown, have been left to chance. The primary education of a lad intended to be a plumber should commence at the earliest age; he has so much more knowledge to acquire than is needed for other trades. When parents learn to give up the early years of their children to systematic study a better time will be inaugurated for artisans. A well-grounded knowledge of arithmetic, practical geometry, drawing, writing, spelling, grammar, and composition (I wish I could add, the use of tools) is easily acquired by an attentive, diligent lad at any National or Board School, and will prove of incalculable advantage to him in the race for pre-eminence as a plumber. If these things are not learned at school the lad will find no other time to pick them up, and he will then be easily beaten and left behind by those who wisely worked while they had the opportunity to do so.

The absence of this preliminary groundwork of thorough primary instruction and education is the great difficulty with which technical teachers of plumbing have to contend. Workmen thirsting for improvement and seeking knowledge, listening with strained ears to lectures and explanations, are from this cause frequently unable to gather up and

retain one quarter of the lesson. The writer has found in technical plumbing classes a need for the most elementary teaching in arithmetic and other subjects, especially for the older workmen. The young lads afford easier ground to work upon, owing to the greater opportunities in these days for acquiring a suitable elementary education. Artisans have told me that the information they gain at one class seems to push out what they learn at another class, and that their minds have no retentive power; but, with judicious technical teachers, who will not try to teach too much at one time, but will teach a little thoroughly well, the students find that the knowledge will remain in their minds and prove of future service, even though they may be unable to frame satisfactory answers at the time, owing to the absence of a good primary elementary education in their youth.

At fifteen or sixteen every lad should have acquired a sound sufficient education to fit him for his apprenticeship during the seven years of work which every youth ought to serve at the bench and on the job, in order to master the plumbing trade. Seven years' apprenticeship is not too long a term for a plumber; it rapidly passes by if the lad be really earnest to learn and anxious to improve. Every particle of added knowledge and skill will add to the power of the apprentice when he becomes a journeyman.

Apprenticeship in plumbing deserves encouragement; the system should not be suffered to die out, though it seems in jeopardy at present.

When employers indenture apprentices they become legally responsible that, by some means, their apprentices shall be properly taught. Where technical schools exist this teaching can be easily secured; but lads require also some encouragement and friendly advice to induce them to take full advantage of the opportunity, and the masters should pay all their apprentices' school fees.

Although technical teaching of plumbing cannot supersede that of the workshop, plumbers' apprentices must learn much more than can be acquired at the bench and on the job before they can hope to become first-class journeymen. Nowadays, masters and foremen are so pressed and hurried they have not time to teach their apprentices, and journeymen are not paid to teach possible competitors.

Technical schools for plumbers should be modelled on lines to meet the requirements of both employers and employed; therefore the education should consist of something less than the higher training of abstract science which demands time, leisure, and costly appliances, and something more than the rule-of-thumb practice of the workshop bench.

The teachers should be both first-class practical plumbers and also scientific theoretical plumbers. There are many plumbers who can do anything with lead, and yet who could not give clear explanations to others of reasons of what they do. Successful teachers must possess a knowledge of the science of the craft, and also a faculty for communicating clear instructions and explanations.

The technical plumbing teachers are required to turn out their pupils with a moderate but suitable possession of scientific attainments, combined with a practical power of applying that knowledge by manual dexterity and inventive capacity, to lighten and improve their daily labours. Theory and practice must go hand in hand. Working men often reject a new suggestion on the ground that it is only theory. No theory is sound unless it can be applied in practice, and no practice exists that cannot be formulated in theory; both must be harmoniously combined in technical education.

The cost of establishing technical schools, with proper appliances and fully qualified teachers, prevents their general promotion in provincial towns; it will be better to make small beginnings, rather than not to move at all

towards improvement. A small technical plumbing school may be started at a first cost of £50 for benches, tools, and materials, and £50 a year for maintenance expenses, wherever a qualified plumber can be found to teach at a moderate salary, in addition to the students' fees and the result fees. Many scientific teachers would be willing to give occasional free lectures.

For plumbing technical workshops, wooden benches will be required, on which to dress the lead, to work up bends, to solder pipe-joints, etc. These benches may be any length, and from 2 feet 6 inches to 3 feet wide, formed of 3-inch hard timber, planed smooth and set level, with sharp rectangular corners and edges. The benches should rest firmly on strong, steady trestles, and so that either side of benches may be turned up alternately.

A melting-pot, holding from one to two hundredweight of lead, set in brickwork over a furnace, will be useful for melting lead for casting, or making solder. The flues should be easily cleaned, and the furnace and ashpit doors should be air-tight and strong.

Plumbers' heating stoves, with proper flues, will be necessary. Each student should, if possible, have a stove to himself alone, when engaged in soldering, or in heating lead for bending or bossing; consequently the number of stoves required will be large, in proportion to the number of students. Half of the workers can be employed on cold work, while the other half are using the stoves and soldering; but if each student can be given his own particular stove, bench, lock-up press, and set of tools, and made personally responsible for them, the comfort and advantage all round will be great, but, unfortunately, so will be the first cost. A sand-box 4 ft. 6 in. or 5 feet  $\times$  1 ft. 6 in.  $\times$  1 ft. 6 in., with iron-founders' moulding sand and a wood cover, will also be required.



One or more good brass-finishers' lathes complete, with tools, will be found most practically useful, where such a luxury can be obtained. Plumbers frequently are glad to know how to use a lathe, and find the knowledge useful in getting them over many a difficulty.

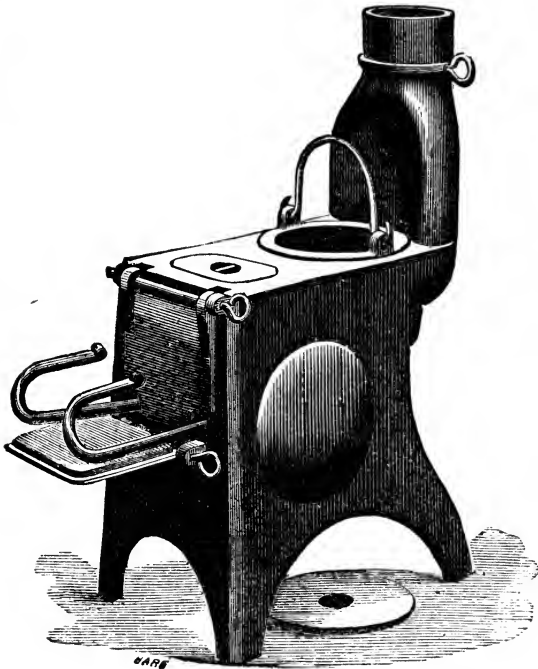

FIG. 1.—Plumber's Heating-stove.

A set or two of stocks and dies, and screwing machines for screwing and tapping iron and brass.

A fixed bench, with a smith's vice or two, a portable smith's hearth and bellows, a light anvil and smith's hammers for dressing and sharpening tools, and a grindstone will be very useful. Lead-burning apparatus may be added also, and a hydraulic testing machine. Water tanks giving various heads of pressure, with pipes of various diameters

leading from each to each other, and to discharge over troughs with wastes on ground-level, with full round-way valves on each pipe and to each end, for experimenting on the flow of water and other effects—these are luxuries of technical teaching that may always be desired, but are beyond the attainment of average schools.

If, however, the teacher will design the system of appliances to suit the number and capacity of his pupils, he can accomplish wonderful results by utilising the students' skill, and can gradually fit up a complete set of appliances for experimental teaching at the mere cost of the materials, while he is at the same time giving the best class of practice—real practice in making tools and fitting plumbing work—vastly increasing the personal interest and delight of his pupils in their work, which is the great secret of a teacher's success.

It will be desirable, also, to get together for such a school specimens of all descriptions of sanitary appliances—water-closets, valves, meters, cowls. Makers and patentees are often glad to present their special appliances to local technical schools, in order to promote the acquaintance of the students with the working of the various parts, so that they may be skilled to fix or repair them in actual practice abroad or at home.

The teacher should be cautious not to advertise any particular appliance, nor to recommend any particular maker by name, but to deal with principles, and if special apparatus be used at all, to use them so as to exemplify principles. The teacher must, however, be free, and it will be his first duty to point out defects or advantages in appliances, to give clear reasons to his pupils for doing so, and always so as to avoid personality.

Models, experimental apparatus, and diagrams for illustration should be all prepared and made by the teacher and

the pupils working together; the necessary apparatus will thus cost much less than if purchased, and will give the pupils a greater insight into the work than a dozen *lectures* on the subject. A verbal description of an apparatus or a process may seem clear or otherwise, but when the pupils help to make the apparatus and to fit its parts together, or carry out a process along with the teacher, they will not be likely to forget what they have thus practically learned. The fingers and hands sometimes afford a surer path to the brain than the eye or the ear. "If any be a hearer of the word, and not a doer, he is like unto a man beholding his natural face in a glass: for he beholdeth himself, and goeth his way, and straightway forgetteth what manner of man he was. But whoso is a doer of the work, that man shall be blessed in his deed."

Teachers should also endeavour to obtain offers of special prizes to encourage their pupils to produce the best work and the best answering. Prizes will often be freely given by those interested in the success of the enterprise, but in all cases, with the exception of apprentices, the pupils should pay a fee proportioned in each place according to circumstances. Technical education, as well as bread and butter, is more appreciated when it costs something to get.

If the teacher can make arrangements to take his pupils once a month to visit works connected with the trade, such as lead works, rolling mills, pipe-drawing mills, iron works, or if permission could be obtained for them to visit large public buildings where plumbing works were in hand, which might be shown in progress and explained by the teacher, a great interest would be given to technical teaching in the students' minds.

Technical education in special night schools cannot alone turn men out as plumbers worthy of the name of craftsmen; along with it an apprenticeship in the workshop for seven

years is needful, and both should run together like a pair of well-matched driving wheels of a locomotive on two different rails, straight ahead to the goal—Success.

Fitting rules to govern apprenticeship will doubtless be recommended by the Plumbers' Company, and, we hope, loyally adopted by the trade as of old time. Suitable wages should be suggested, regulated in accordance with the value of the apprentice to his master, a tangible payment, advancing year by year. Indentures should contain a clause compelling attendance at a technical school.

In this age of keen, razor-edged competition at home and abroad the public benefit conferred by technical schools is beginning to be appreciated, so that many worthy and philanthropic people have devoted a portion of their wealth to the promotion and extension of the movement. It is not too much to say that money could not be spent more nobly or to better purpose. The future prosperity of Great Britain and Ireland now depends more upon the progress and successful extension of technical schools, and upon the enthusiasm and perseverance of the rising generation in taking full advantage of them, than perhaps any one of us yet fully comprehends.

One of the most valuable endowments for a plumber is the power of drawing, and this faculty should be educated prominently in all technical classes. Drawing-boards, blackboards, tee-squares, rules, triangles, and compasses, should be found at work in every school.

Drawing classes should not be taken on the nights when hammering and practical plumbing is in full swing; quietness is essential for delineation, and a plumbing shop, even a young one, is not such a place of quietness and peace as is suited to the contemplative mind of a young artist in chalk. On the special drawing nights the teacher may with

advantage arrange a large blackboard in view of his class, and on it rapidly sketch with chalk, drawn purposely out of all proportion, an irregular form of any kind—a trap, a sanitary appliance—carefully giving the dimensions of every part necessary, in order to enable the students to reduce the roughly sketched figure accurately to a given scale, either with chalk on their blackboard, or on drawing-paper; or he may set as a copy any form of lead-work, and require the students to prepare drawings of the surface of sheet lead necessary to be cut out in order to construct a similar work in lead, the students showing the methods by which they arrive at the results; or actual models of appliances may be placed before the students, and, either with or without measurements taken by rule from the model, the students may be required to draw from the round, diagrams, in plan, elevation, and perspective, and to delineate various sections of the model.

It can hardly be expected that all working plumbers who are capable of being teachers of plumbing shall also be advanced teachers of drawing, but the better they understand drawing the better will they teach plumbing. In many schools arrangements could be made for a drawing-master to give an hour's lesson once or twice a week in conjunction with the teacher of plumbing.

Practical geometry and drawing should go hand in hand, not merely by having diagrams hung up and letting the students copy them, not by setting the students to work at problems which they are likely to forget before they leave the room, but by drawing on the blackboard before their eyes, or by setting the students themselves to draw, the geometric figures which they may hereafter need to construct in real work. Neatness and care in drawing geometrical figures should be impressed upon the students; the object

of such practice is to secure accuracy, which can only be attained by precision in practice.

Take one easy problem, viz. to bisect a straight line. Here we have a diagram, and the directions: "From A

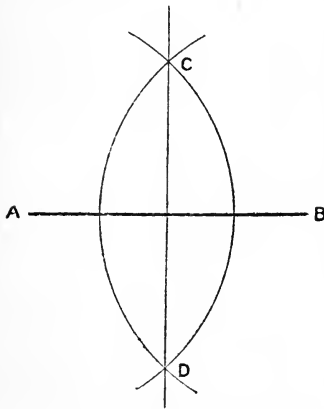

FIG. 2 —To bisect a straight line.

and B, with any radius greater than the half of A B, describe arcs cutting each other in C D. From C draw a right line to D, and it will bisect the line A B."

Now, although that is the simplest problem in practical geometry, we can perhaps understand how much better and clearer is the practical method of teaching. The

teacher takes a blackboard; he draws the straight line which he wants bisected, or divided

equally in two; he takes the chalk, and, compass in hand, he shows the meaning of "any radius greater than half of A B"; he describes the arcs, showing them cutting each other in C D, and he draws the bisecting right line. He rubs them out, and invites his pupils forward to repeat the process, and the lesson is taught practically, so that it can never be forgotten.

Practice in taking tracings off architects' plans should be afforded to the pupils, as this has often to be done in daily work. Drawing to scale should be taught, and the students enabled to read off architects' plans of buildings and fittings. Good old disused plans as specimens may be obtained from local architects, who are generally willing to help forward such classes. These plans should be explained over and over again, if necessary, till each student understands every detail. Portions of the plans should be enlarged from,

say,  $\frac{1}{8}$  inch scale to 1 inch scale per foot, as working drawings of details.

The object of the teachers should be to enable each student to read and understand any architect's plans they may meet in their daily work, to be able to measure off the lengths of piping, sizes of lead for roof gutters, flats, flashings, cisterns, troughs, etc., and to lay out the plumbing work necessary and measure up the quantities from the plans.

There are very few architects who would not prefer to deal with a master or journeyman able to understand his plans, rather than with those who would need continual information and instruction. A well-educated plumber should be able to understand a plan and specification, to know the proper way to carry out the work, and to give sound reasons why he would do the work one way in preference to any other. That is the man who will make his own way and succeed in his business. If a journeyman plumber can do good sound work quickly we do not say he should necessarily have any theoretical knowledge, but we say that without such knowledge he must ever remain a plumbing machine, doing only just what he may be told to do by those above him; he never can progress.

It is not possible, nor would it be desirable, to limit or determine the exact amount of mechanical practice or handiwork which technical teachers should allow to their pupils in the schools; each teacher is bound to give careful consideration to this matter, so as not to use valuable material lavishly, and yet to see that his pupils are fairly instructed in the practical principles of joint-making, bending, bossing, lead-laying, soldering, etc.

This hand-practice should be so arranged and so limited by the teacher in accordance with the means at his disposal as not to become in any sense a substitute, in the student's

mind, for the actual daily work at the bench and on the job, but rather to illustrate and explain the reasons why certain work is done so and so in actual practice—why one way of doing it is wrong and another way is right. Lead-burning, zinc and copper work, gas-fitting, and iron pipework should not be neglected, and the practical principles of heating by hot water, both by high and low pressure systems, should be explained.

The students should be trained to apportion the metals and make the various solders used in the trade, to find what impurities will injure solders, and how they may be purified. If possible, without going too deeply into the chemical question, various kinds of waters should be examined and criticised; ready and simple means of roughly detecting impurities in water and air should be shown by easy experiment; the method of softening hard waters should be tried. Hydraulics and hydrostatics, even in the most elementary fashion, may well be considered; the more thorough and complete such teaching, the better will be the position of the pupils in after years. Many a practical plumber needs to be taught that he cannot decrease water-pressure on his pipes by reducing the size of his cistern, unless he also reduces the level of the water.

The standard for a sanitary plumber will be much higher than it is at present. To attain that standard opportunities at school must be diligently grasped, apprenticeship under a practical master should be steadily served, and during apprenticeship three or four evenings a week should be given to attendance at classes in technical schools for the study of mathematics, drawing, practical geometry, plumbing and metal-plate work, mechanical engineering, building construction, steam, heat, hydrostatics, hydraulics, aerometry, and any other subjects available bearing on the plumber's trade. Examinations should be passed and certificates



obtained in these subjects, which will fully occupy the evenings of the seven years' apprenticeship.

Such a preparation for a trade may appear to some too arduous; but it will bring a full reward, not only by the conscious power which skill and knowledge give, but also by success and prosperity in life.

## CHAPTER III.

### ELEMENTARY SCIENCE FOR PLUMBERS.

FOR practical teaching purposes the author prefers once for all to explain in this chapter the elementary natural science which plumbers specially require to know rather than to drag in frequent explanations of phenomena here and there through future chapters.

Practical plumbing rests upon the foundation of natural science; therefore it is as important for plumbers to attain a grasp or comprehension of the science underlying their craft as it is important for them to know how to handle their tools. Without possession of a fair elementary knowledge of this science, workmen have no true claim to the title of plumbers. Mere handicraft skill is insufficient.

Science is a name which frightens working men, because they have never been made acquainted with its simplicity, beauty, and usefulness.

Science is knowledge; it is truth ascertained, defined, and determined accurately. Scientific research is a seeking after truth for its own sake. There is nothing in science to object to; but, on the contrary, everything for the humblest artisan to desire and to seek after earnestly.

Science is of the utmost practical importance to every plumber. We can never properly acquire for ourselves, nor communicate to others, accurate technical knowledge in any trade, unless we have gained some actual acquaintance with the natural forces and laws underlying and connected with that trade.

Every plumber and every teacher of plumbing should seek diligently and earnestly for this knowledge. The more we learn the better shall we be fitted for our work, and the easier and pleasanter shall knowledge become. Popular education in physics, or the knowledge of nature, has been so neglected that very few otherwise well-educated people are prepared to explain, or even to understand, the causes of the most simple practical phenomena occurring daily within their observation. A banker ignorant of arithmetic and book-keeping, or a doctor without a knowledge of anatomy and medicine, would be very likely to fail in his profession, and to do serious injury both to himself and to others.

The world is now learning that, unless a manufacturer understands the science governing the processes of his manufacture, he is not to be depended upon for the best work, and therefore the world is looking for plumbers and for technical teachers of plumbing who make it their aim to know their business thoroughly. Knowledge of the forces of nature is more essential for plumbers than for the artisans of many other trades.

Let us first think in a broad general way of our subject. Energy and matter are the two great realities of the universe. We are surrounded by them; we observe and can study their properties, and may use them to our advantage when we have learned the way to do so. We can direct, control, concentrate, store, and utilise both energy and matter, but we can neither create nor destroy; they are immutable and indestructible, fixed quantities, definite existing realities. Yet no man by his own searching has found out where they originally came from, or what they definitely consist of. We know something of their properties, and it is with their properties and effects we have to do as practical men.

Physics is the study of the energy which acts upon the

matter composing the universe, and it is or should be of intense interest to the technical teacher of plumbing, and to every one of his pupils.

Energy is the power of doing work, and, when applied as force, it changes the state of a body from rest into motion, or from motion into rest.

Energy is of two kinds—energy of motion and of position. The actual energy of motion acquired by a jet of water thrown, as against the attraction of gravitation, by any external agency to the top of a house, appears to become gradually absorbed as it ascends with gradually decreasing velocity. If that jet of water be caught and stored in a tank on the top of that house it exerts no longer the energy of motion; but, though held at rest, it possesses, stored up, an energy of position exactly equal to the amount expended in sending it there; it possesses a potential energy, which plumbers call a “head of water.” Nearly all the energy in this world may be traced to the sun; but that luminary must have received its energy from some great power in order to distribute it to us, and, unless the sun is being replenished, the day will come when he himself shall be no more—his energy not destroyed, but transferred to other stores.

It is the sun’s energy that warms the air, causing the winds to blow; evaporates the waters of the ocean, forming the clouds and the rain; dispenses heat and light, causing the plants to grow and timber to form; reacting by chemical processes, and converting them into stores of coal.

We are now excavating from coal mines, peat fields, and oil wells the energetic sunshine of past ages, redeveloping the energy of power, by raising steam and employing it in various engines to do work once more.

Study may be considered a mental energy of motion;

while knowledge acquired and stored for use is clearly mental energy of position, ready to be utilised when required in brain work.

When we work either with our brains or our hands we are using up energy; but it is neither lost nor destroyed. All work proceeds from energy, so the plumber who possesses most energy should get on best in his trade. Energy is the workman's capital: he requires a good share to commence business with, stored not only in his muscles, but also in his brain.

We have heard that this energy proceeds from the sun; but by what means? Well, the heat and light causes food to grow; the food is eaten, and by chemical processes, in which the sun takes part, it is transformed into flesh and blood, brain and muscle.

A certain proportion of our breakfasts and dinners, accurately measured by scientific men, goes to our muscles and our brains.

There are a great many men who would always be ready and willing to store an immense amount of energy if it only depended on taking in breakfasts and dinners! but as food requires digestion and assimilation to render it of use, so the muscles require practice and the brain study to develop and direct their powers.

Thus the force or muscular energy which gives motion to or stops our tools, and the thought or brain energy which guides and regulates the manner of using them, depend not only on practice and study, but on the regular supply of food, which we know depends on the influences of the sun; and if we would look further back we may reverently acknowledge our ultimate dependence on the power and beneficence of the Great Creator, in whom we are told that we live and move and have our being.

Matter is the vehicle or carrier of energy. The vast

energy in the attraction of gravitation, the attraction of cohesion, and the attraction of chemical affinity cannot display its effects and powers without matter to act upon and through. Matter differs from energy in being essentially material.

It possesses volume or extent, impenetrability or occupying substance, inertia, indestructibility. These are inherent properties of matter, and are to be distinguished from its accidental properties, such as weight, smell, taste, etc., which depend on circumstances.

It is not possible to form any conception or idea of matter without allowing that it possesses volume or extent; the very smallest atom conceivable must have length, breadth, and thickness, and must therefore occupy or fill a definite space, however minute. Into this space no other atom can enter until the occupying atom has moved away. This is the simple meaning of extent or impenetrability. We may be assisted to realise the idea by comparing in our minds the minutest atom of matter which has length, breadth, and thickness, occupies space, and can even be weighed, with the point in geometry which has neither length, breadth, nor thickness, occupies no space, and cannot be weighed, and therefore is not matter or material, but something clearly definite for all that, marking accurately a precise position in space, and serving a useful purpose in science and art.

Matter is stated to consist of simple elementary atoms which cannot be hurt, destroyed, or divided. Philosophers have discovered sixty-four such elements, and many more may yet remain unknown. These combine in manifold ways, forming compound substances—chlorine and sodium forming salt; silicon and oxygen forming sand; oxygen and hydrogen forming water; oxygen, nitrogen, and carbonic acid gas forming air. All solids, liquids, and gases are

composed of these little atoms, or molecules, or particles of matter, and each substance is formed of definite and distinct particles, so small that our minds are unable to realise their extreme minuteness.

Suppose we could subdivide one grain of salt, for instance, until we finally arrived at the smallest particle in which it could exist as salt. This minute molecule of salt contains two distinct elements, chlorine and sodium, and is therefore capable of being further subdivided into the atoms of those elements, which when separated are no longer salt, but simple sodium and chlorine.

If we can conceive the smallest particle visible to us in the most powerful microscope, measuring, say, the  $\frac{1}{1000000}$ th part of one inch, that minute particle of matter contains many millions of its molecules. The realisation of such extreme minuteness is not easy to our minds.

. These particles of matter, whether in a solid, liquid, or gaseous state, are, as already stated, in a condition of intensely rapid motion, though they seem to us to be at rest.

The molecules or particles of solids, such as iron or lead, are confined by their surrounding molecules in a certain mean position, about which they vibrate in never-ceasing motion. The molecules of liquids and gases, such as water and air, are not so confined, but are free to diffuse themselves throughout their mass in every possible direction, striking and jostling each other like a swarm of midges, every collision changing their direction of movement.

The pressure of gases is considered to be produced by this marvellously rapid movement, so rapid that the atoms of hydrogen gas come into collision eighteen hundred million times in every second of time. Try for an instant to realise that statement.

Steam, air, or gas confined in any closed vessel presses

against the sides with a pressure due to the number of collisions or impacts of the molecules against the sides. In a cubic inch of any gas—sewer gas, for instance—at a standard temperature and pressure, you have the same number of molecules of the gas. These strike the sides of the enclosing vessel, or drain, or soil-pipe, a certain number of times, producing a certain pressure. If you introduce by any means double the quantity of gas, say two cubic inches, you double the number of particles, and consequently you double the number of collisions and you increase the pressure. You may also increase the rapidity of the collisions and the consequent pressure without adding to the number of the particles of the gas confined in the vessel, drain, or pipe, by simply applying heat, which causes them to bombard the sides more rapidly, the pressure on the sides increasing as the squares of the velocities. Heat compels bodies to change their condition; it pulls asunder the particles of ice, and we may observe that during the process of melting this heat has no effect on the mercury column of a thermometer placed in contact, which stands steady at the freezing point of 32° F., the added heat being all expended in tearing the particles of ice asunder and changing the solid into liquid.

If we continue to apply heat to the water thus formed the mercury column will rise until it arrives at the boiling point of 212° F., and there it will remain because the added heat is all expended in separating the particles of water into steam. The comparative dimensions of this one substance under the three forms of solid ice, liquid water, and gaseous steam, are 11 cubic inches ice = 10 cubic inches water = 1,650 cubic inches steam.

For experiment fill a light zinc cylinder with steam, quickly seal it air-tight, and pour cold water on it; the steam is instantly condensed, and the cylinder collapses. If



a strong vessel containing ten cubic inches of water be subjected to the action of frost the water at the instant of freezing into ice will burst the vessel, because there is not space for the additional cubic inch which that ice occupies.

This expansion of water at freezing point to the extent of one inch in every ten inches is the cause of the bursting of exposed lead pipes during winter time. When matter thus expands it becomes lighter bulk for bulk; therefore, when ten inches of water become eleven inches of ice, each inch of ice is lighter than each inch of water. Ice, therefore, floats on water. If, on the contrary, it became heavier and sank, it is obvious that lakes and oceans would in time become solid ice. Ice at the bottom of the ocean would escape the melting heat of the sun, and year by year freshly formed ice would sink and rapidly accumulate.

Matter possesses an inherent property called inertia. Newton's first law of motion may be thus stated. Matter at rest must remain at rest until some external force sets it in motion, and matter in motion must continue in motion in one straight line until some external force stops it or changes the direction or speed.

Inertia may be simply illustrated by placing one pound of lead on a sheet of tin-plate; suddenly withdrawing the tin-plate sideways the lead remains stationary until the support is gone, when it is drawn to the ground by the force of gravity.

The inherent inertia in the mass of lead matter prevents it following the tin in a sudden horizontal movement, no force acting to compel motion sideways.

As we sit or stand we are being carried round on the surface of the earth at the rate of four hundred miles an hour; at the equator men are carried round at the rate of a thousand miles an hour. If our bodies did not possess

inherent inertia the earth would pass under our feet at the rate specified when we jumped upwards. Inertia causes some of the molten lead in a plumber's solder-pot or ladle to be left behind if the pot is jerked suddenly from the fire. This resistance offered by matter is termed *vis inertiae*, or the force of inertia.

The inertia of matter can be further illustrated by hanging three jars by a string side by side—one full of sand, one full of water, one full of air. Twist each round a hundred times. The solid sand will be the slowest to commence revolving, because of the inherent inertia of the sand requiring time to have the motion of the jar communicated to it, but once fairly started it will keep revolving the longest, also owing to the inertia of the solid sand. The water-jar will start revolving quicker, but will leave the liquid body of water behind, as the liquid allows the jar to slide round it, not instantly communicating its motion to the water; owing to inertia the water remains comparatively still, and acts like a check or brake by friction on the revolution of the jar, pulling it up and stopping its motion long before the sand-jar has ceased to revolve. The air-jar, not being acted on by any matter possessing so much inertia as sand or water, is simply affected by the lesser inertia of the gaseous air, and will commence to revolve quicker and to cease revolving quicker than either the sand-jar or the water-jar.

Matter is indestructible. No known human power can destroy matter. You may compel it to change its appearance or to become invisible to our eyes, but the elements or molecules will still exist, capable of being brought back again to the condition you succeeded in altering them from.

If, for instance, you take a piece of marble or chalk, into which carbonic acid had been absorbed and stored up millions of years ago, and if you decompose the solid with

hydrochloric acid, the same molecules of carbonic acid gas will be evolved, possessing the same properties, unchanged, which they possessed millions of years ago before their imprisonment in the lime. You can extinguish the flame of a taper by plunging it in this gas, or you can pour the gas over a flame, as one pours water, with the same effect it would have produced millions of years ago. The experiment is an interesting one, and can be tried without difficulty. The importance to plumbers of an elementary knowledge of these subjects will become more apparent to each artisan in proportion as he obtains more of that information. Plumbers often meet this dangerous gas when fixing or repairing pumps in deep closed-in wells. Its presence is detected by lowering a lighted candle into the well, when the flame will be extinguished, as the man's life would be under similar circumstances.

The universal force of gravity is one of the physical phenomena of nature which intimately concern the plumber in his business, and he will be wise to endeavour to comprehend something about it. Gravity is that mysterious omnipresent power by which every particle of matter attracts every other particle. By the force and effect of gravity, under the heat of the sun, the vapour and the clouds are caused to ascend, the rain and the dew to fall. It causes the upward springing of the fountain into the air, as well as the flow of rivers downwards to the sea; it causes water to flow through pipes, and sewage to discharge through drains; it causes water to rest in our cisterns and to flow out from them; it enables us to ventilate and heat our buildings, and it produces the circulation of hot water in pipes; it governs and controls every action of our bodies and every detail of our craft. No particle of matter, solid, liquid, or gaseous, invisible though it may be to our eyes, is too minute to be free from this universal force of gravity,

sometimes called weight. The word "weight" conveys the idea of the downward attraction towards the centre of the earth alone. Gravity is more than that; it is a universal force of attraction, innate in and belonging to every particle of matter, whereby every atom must of necessity attract every other atom.

If you place two blocks of stone on a bench, one large and one small, they are drawn downwards and held from flying together by the overpowering force of gravity exerted on them by the enormous mass of matter in the earth; but these two blocks have a mutual attraction for each other, so that, if all other attraction could be destroyed, they would instantly fly together—the large block would draw the small block towards it and the small block would draw the large block towards it, each moving a certain distance at a certain speed in exact proportion to their relative mass. If they were blocks of equal mass each would move an equal distance at an equal speed and meet exactly half-way. Plumbers, as practical men, should seek to realise this universal attraction.

The sun attracts the earth, and the earth attracts the sun. The earth attracts the moon, and the moon attracts the earth, each in proportion to its mass and to its distance apart from the other. The ebb and flow of the tides are chiefly caused by this attraction of the sun and moon. The waters, being drawn up from the earth towards the sun and moon, tend to follow these bodies, producing the tides.

This force of gravity has been accurately measured. All bodies, though differing in volume and mass, such as lead and water, fall in a vacuum at an equally increasing velocity, and it has been ascertained that at the end of one second of time in falling the velocity acquired is 32·1948 feet, or 32·2 feet nearly in one second, and this is taken as the measure of the force of gravity. It is important

that every plumber should know and remember that all hydraulic calculations are based upon that unit of measurement which is algebraically called  $g$ . The flow of water through pipes and drains, and along open channels, and from cisterns and reservoirs is solely caused by this force of gravity acting on each atom of the water, directly tending to draw all towards the centre of the earth, a tendency which is checked by the bed, or channel, or vessel by which the water is carried or supported. A knowledge of the laws of gravitation means, to the hydraulic engineer, a knowledge of the foundation on which his practice rests. To the philosophers Galileo and Newton we are indebted for this knowledge. We here find the highest discoveries of science serving for the daily practical guidance of engineers and artisans.

One law of gravitation determines that all bodies on the earth, whatever may be their volume and mass—lead, water, etc.—fall freely in vacuo, with equally increasing velocities, over the space of 16·1 feet in one second, 64·4 feet in two seconds, 144·9 feet in three seconds, 257·6 feet in four seconds.

We find these distances easily by squaring the number of seconds during which the body is falling, and multiplying the rest by 16·1.

For one second	.	.	$1^2=1 \times 1 = 1 \times 16 \cdot 1 = 16 \cdot 1$	feet in one second.
„ two seconds	.	.	$2^2=2 \times 2 = 4 \times 16 \cdot 1 = 64 \cdot 4$	„ two seconds.
„ three „	.	.	$3^2=3 \times 3 = 9 \times 16 \cdot 1 = 144 \cdot 9$	„ three „
„ four „	.	.	$4^2=4 \times 4 = 16 \times 16 \cdot 1 = 257 \cdot 6$	„ four „
„ eight „	.	.	$8^2=8 \times 8 = 64 \times 16 \cdot 1 = 1030 \cdot 4$	„ eight „

Galileo discovered the law that the space described by bodies falling freely under the action of gravity is proportional to the square of the time elapsed from the beginning of the fall.

The top of the flagstaff on the Eiffel Tower in Paris is

about 1,030 feet high; we find that a bullet dropped from this height will reach the ground in eight seconds, and will have attained a velocity of 257·5 feet per second at the end of the eighth second.

To find the space fallen through in any given time multiply the square of the number of seconds by 16·1, which is the distance fallen through in feet during the first second of falling—

$$8^2 = 8 \times 8 = 64 \times 16\cdot1 = 1,030\cdot4 \text{ feet in eight seconds.}$$

The velocity increases second after second in falling in a steady ratio.

To find the velocity in feet per second acquired in falling, for any number of seconds, at the end of the final second, multiply the number of seconds by 32·2—

$$8 \times 32\cdot2 = 257\cdot5 \text{ feet velocity per second at end of eighth second;}$$

or multiply the distance fallen through in feet by 64·4, and take the square root of the product—

$$1,030 \times 64\cdot4 = 66,332; \quad \sqrt{66,332} = 257\cdot5 \text{ nearly} = \text{velocity in feet at end of eighth second;}$$

or multiply the square root of the space fallen through in feet by the square root of 64·4, the result will be the same—

$$\sqrt{1,030} \text{ feet} = 32\cdot1 \text{ nearly; } \sqrt{64\cdot4} = 8\cdot025 \times 32\cdot1 = 257\cdot5 \text{ nearly} = \text{the velocity acquired in feet per second at the end of the eighth second of falling.}$$

A bullet dropped from the dome of St. Paul's, London, will fall the 272 feet in 4·3 seconds. In every case a fraction of time must be allowed in addition, for the resistance of the air medium acting on the falling body. The depth of very deep wells may be approximately measured in a similar fashion, allowing extra time for the sound of the bullet or stone, on striking the water, to travel up to the ear.

In calculations for plumbing and hydraulic work fractions are frequently neglected for convenience, but then care should be used to insure that the actual results shall be more, rather than less, favourable than the calculated results in consequence. Accuracy is always an advantage, and should be cultivated in all calculations.

In the case of a falling body the velocity is rapidly increased if no resistance or friction affects it, as in vacuo; in the case of an ascending body the velocity is diminished in the same ratio.

In order to throw a column of water 16 feet high it must be given an initial velocity of 32.2 feet per second to overcome the attraction of gravity, together with an additional velocity to overcome the resistance or friction of the air.

To obtain any given velocity in water flowing through pipes and drains the pipes must be given not only the fall required by the laws of gravity to produce that velocity, but also an additional fall or head to overcome resistance or friction offered by the surface over which the water flows and by the air through which it passes.

If we could obtain a vertical glass tube 16 feet high and, by extracting the air, form a perfect vacuum within the tube, and if we could, without admitting air, let fall a leaden shot and a drop of oil, they would each, as before explained, fall in one second, and would each have attained a velocity of 32.2 feet per second at the end of the second of time occupied in falling. Let fall some water in the same tube; it will drop in the same space of time, and remain in a mass unbroken, producing a dry click, like a solid, on striking the bottom. Such a tube forms what is called a "water hammer." Smoke also falls in vacuo, for smoke has weight, and all gases have weight.

The specific gravity of various solids, liquids, and gases intimately concerns plumbers.

Every solid, every liquid, and every gas possesses a density specific or peculiar to itself, and different relatively to all other substances. This is known as its specific gravity. It is found in three ways, either by the hydrostatic balance, the hydrometer, or the specific gravity flask.

The specific gravity of each solid and liquid is ascertained and determined generally by careful comparison with an equal bulk of pure distilled water at the temperature of 39° F. or 4° C., the temperature at which water attains its greatest density, before it expands in freezing. In our country the weight of a cubic inch of water at 60° F., with atmospheric pressure at 30 inches of mercury, is taken as the standard. It weighs 252.458 grains. There are 7,000 grains in 1 lb. avoirdupois; 70,000 grains in a gallon; 277.272 cubic inches in a gallon.

The specific gravity of gases is ascertained by comparison with dry atmospheric air at 60° F. and 30 inches barometric pressure as the standard.

Liquids and gases of greater specific gravity will sink below liquids and gases of less specific gravity. Thus water will sink below oil in a mixture; molten lead will sink below molten tin in plumber's solder; molten lead and tin will sink below molten zinc; carbonic acid gas will sink below atmospheric air.

By acquaintance with the specific gravity of his materials, etc., the plumber knows what results he shall find in any combinations. He knows that while using his solder he must keep it stirred, else the tin must rise to the top, because the lead, owing to its greater specific gravity, will sink to the bottom; he knows that if accident or mischief brings zinc into his solder he can purify the solder by



melting, until the zinc is driven to the surface, where it can be skimmed off. The practical plumber, of course, is aware of these facts; but science explains to him the reason and the cause of them.

The plumber knows that on going down into a well to fix a pump he may find a layer of dangerous carbonic acid gas lying at the bottom, because the specific gravity of that gas is greater than that of air, and thus he is specially warned of a danger to his life, and can take due precaution in time.

Some men will say, "We all know of that danger without science to teach us"; but it is certain that the practical man who knows something, by scientific study, of the specific nature and deadly effects of carbonic acid gas, will realise more thoroughly the danger, will remember about it more certainly at the proper time, and will know better what measures to take, under various circumstances, to secure safety for his own life and for the lives of his fellow-workmen.

Mercury is thirteen and a half times and lead eleven times denser than water; lead is thirty times denser than poplar wood; the specific gravity of mercury is thirteen and a half times greater than the specific gravity of water, and that of lead is thirty times greater than that of poplar wood.

Place two small glass vessels one in each pan of a scales equally balanced; fill one with water, and pour mercury into the other until the balance is again attained. Find a small vessel which this quantity of mercury will exactly fill, and the quantity of water in the opposite pan of the balance will exactly fill the same vessel thirteen times and a half. So also one cubic inch of lead placed in the scale will require to have thirty cubic inches of poplar wood in the opposite scale of the balance to secure equilibrium.

Plumbers will find a table of the specific gravity of a few solids, liquids, and gases serviceable for reference from

## 38 DOMESTIC SANITARY DRAINAGE AND PLUMBING.

time to time; it is unnecessary to overload the memory with figures, but it is an advantage to have them at hand and available.

### SOLIDS.

Iridium . . . . .	23·00	Sandstone . . . . .	2·60
Platinum, cast . . . . .	20·86	Porcelain . . . . .	2·24
„ hammered . . . . .	22·06	Rock Salt . . . . .	1·92
Gold, cast . . . . .	19·26	Ice at 32° F. . . . .	0·926
Lead, cast . . . . .	11·35	Ivory . . . . .	1·92
Silver, cast . . . . .	10·47	Chalk . . . . .	2·65
Bismuth . . . . .	9·82	Sulphur . . . . .	2·08
Copper, cast . . . . .	8·85	Coal . . . . .	1·3
Copper wire . . . . .	8·95	Phosphorus . . . . .	1·77
Brass . . . . .	8·39	Amber . . . . .	1·08
Nickel . . . . .	8·38	Wax . . . . .	0·97
Steel . . . . .	7·82	Sodium . . . . .	0·97
Iron, hammered . . . . .	7·79	Ebony . . . . .	1·19
„ cast . . . . .	7·24	Oak . . . . .	0·91
Tin . . . . .	7·29	Mahogany . . . . .	1·06
Zinc . . . . .	6·862	Box . . . . .	1·32
Antimony . . . . .	6·71	Beech . . . . .	0·85
Arsenic . . . . .	5·959	Ash . . . . .	0·84
Iodine . . . . .	4·94	Maple . . . . .	0·75
Mica . . . . .	2·93	Walnut . . . . .	0·68
Sugar . . . . .	1·6	Pitch pine . . . . .	0·66
Diamond . . . . .	3·53	Yellow pine . . . . .	0·65
Crown glass . . . . .	2·76	Elm . . . . .	0·60
Flint glass . . . . .	3·78	Cedar . . . . .	0·59
Plate glass . . . . .	2·37	Larch . . . . .	0·54
Aluminium . . . . .	2·67	Poplar . . . . .	0·38
Marble . . . . .	2·65	Cork . . . . .	0·24
Granite . . . . .	2·75	Elder pith . . . . .	0·08

### LIQUIDS AT 32° F.

Mercury . . . . .	13·596	Linseed oil . . . . .	0·940
Sulphuric acid . . . . .	1·85	Spirits of wine . . . . .	0·835
Nitric acid . . . . .	1·52	Proof spirit . . . . .	0·920
Phosphoric acid . . . . .	1·55	Bordeaux wine . . . . .	0·994
Hydrochloric acid . . . . .	1·218	Burgundy wine . . . . .	0·991
Muriatic acid . . . . .	1·200	Olive oil . . . . .	0·915
Milk . . . . .	1·03	Ether, hydrochloric . . . . .	0·874
Sea water . . . . .	1·026	Turpentine . . . . .	0·865
Vinegar . . . . .	1·026	Brandy . . . . .	0·837
Tar . . . . .	1·015	Human blood . . . . .	1·053
Water at 39° F. . . . .	1·000	Alcohol . . . . .	0·796
Water at 32° F. . . . .	0·9998	Ether, sulphuric . . . . .	0·720

GASES AND VAPOURS COMPARED WITH AIR AT SAME TEMPERATURE  
AND PRESSURE.

Oxygen . . . . .	1·103	Carbonic acid gas . . . . .	1·529
Nitrogen . . . . .	0·972	Sulphurous acid gas . . . . .	2·247
Hydrogen . . . . .	0·069	Sulphuric acid gas . . . . .	2·763
Bromine . . . . .	5·395	Marsh gas . . . . .	0·559
Chlorine . . . . .	2·470	Olefiant gas . . . . .	0·978
Steam . . . . .	0·622	Coal gas . . . . .	0·500
Ammonia . . . . .	0·596	Air . . . . .	1·000
Iodine . . . . .	8·701		

## GASES COMPARED WITH WATER AT 39° F.

Oxygen . . . . .	0·001432	Hydrochloric acid gas . . . . .	0·00164
Atmospheric air . . . . .	0·001293	Nitrous oxide . . . . .	0·00197
Nitrogen . . . . .	0·001267	Carbonic acid gas . . . . .	0·00198
Hydrogen . . . . .	0·0000894	Water at 39° F. . . . .	1·000
Chlorine . . . . .	0·003209		

Cohesion, or the attraction of cohesion, is that energy or force which we see displayed around us, uniting and holding together, with various degrees of effective power, the different particles of every solid and liquid substance. We see phenomena the most curious daily passing before our eyes, and hardly consider them worthy of notice, yet they form some of the scientific questions most difficult of explanation and solution. If a piece of ice be thrown into the air all its particles are held together by the attraction of cohesion, and all participate in the motion equally. If we grind the ice to fine powder and pour the powder down a sloping board the particles will flow over each other, resembling in appearance the flow of water; or if we place the powder in a vessel with a hole in the bottom the powder will flow out through the hole in appearance like water, but each small grain in the powder is a true solid, the particles being held together by cohesion. Although in grinding the solid to powder we have annulled the cohesion between many particles, we have not succeeded in annulling it in all. But when we apply another power of nature, that of heat, to the ice in solid or in powder,

we find that all the particles are torn asunder, and have their cohesion so greatly reduced that they will slide about and roll over one another and mingle every way under a very slight force indeed; yet, although the attraction of cohesion seems to have changed its character in water, it still exists, holding the particles in close contact, unless some other greater force overcomes it, as when water is forced into a spray sometimes like fine dust by the resistance of the air upon its particles when in motion. If this water be driven into steam all the power or energy of cohesion appears destroyed between the particles; yet we know it remains in existence, and reasserts its power and presence in dragging the steam back into the form of water or ice.

We find, therefore, affecting our very existence, some close mysterious relation between the powers of heat and cold and the power of the attraction of cohesion; and also that we are, in fact, surrounded in our daily life and work by strange mysterious influences of nature, of deep interest to everyone personally, and well worthy of thoughtful consideration. Apply heat to lead, and witness its effect in the diminution of the attraction of cohesion; mould this lead into a bar, allow the heat to disperse, and witness that cohesion is again established; use force and break this bar in twain, the cohesion then appears to be destroyed at the points of fracture. Scrape the fractured ends and make them smooth and bright, and by great pressure together they may be caused to cohere, so that the upper piece will lift the lower; and that this effect is not due to adhesion alone may be seen by observing, when the two pieces of lead are again separated by force, a limited number of small lead pin-points where cohesion occurred. Cohesion, which in metals is known as the property of tenacity, is not to be confounded with adhesion, which refers to the clinging together of bodies of *different* natures, as illustrated

by the use of glue and paste in uniting surfaces. In the two pieces of lead mentioned the attraction of cohesion is seen to be very imperfect; it cannot completely re-establish its power until sufficient pressure or force, applied by heat or otherwise, brings all the particles of lead into normal contact. Relative tenacity in metals is determined by ascertaining the exact weights required to break wires formed of the metals in equal lengths and gauge. Lead possesses a low degree of tenacity, while iron possesses tenacity in a high degree.

Capillarity, or capillary attraction, is a natural force with which plumbers are obliged to reckon.

Instances of this capillary action occur, and may be observed, if a glass tube of very small bore, having both ends open, is dipped into a vessel containing water. The water will rise in the tube to a higher level than the water in the vessel, and so remain in equilibrium, apparently in opposition to the law by which all liquids are stated to seek one level. If the same tube be dipped in liquid mercury, we may observe that the mercury will not rise in the tube to the level of the mercury in the vessel, but will sink and remain in equilibrium at a lower level.

The surface of the water in the tube will be concave, the outer edges curved upwards, clinging to the walls of the tube as if attempting to climb; but, strangely enough, the surface of the mercury will be convex, the outer edges curved downwards, as if seeking to descend in the tube. The result is the same in air or in a vacuum.

When laying sheet lead in gutters and on flat roofs it

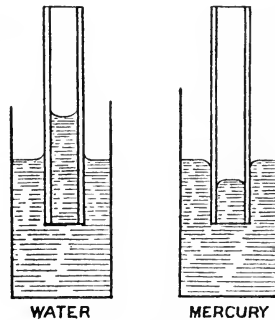

FIG. 3.—Capillary Action.

has been found, when two sheets of lead are allowed to overlap and lie one upon another *closely*, that unless precautions are taken to prevent it, water will rise to a considerable height between the two sheets, and cause serious injury, by soaking the underlying plaster and woodwork, which the lead is intended to protect.

In water-traps, placed under troughs and sinks to protect houses from the entrance of drain air, it has been found that a piece of rag, a few strands of fibre or filament, caught and hanging over the outer weir of the trap, will have the dangerous effect of emptying the trap; for, by the action of capillarity, the threads or filament allow the water to rise through them out of the hollow of the trap, and to escape by rapid evaporation, or by trickling slowly away down the outer waste pipe, leaving the house exposed to the danger of free entrance of foul air. From damp subsoils the water will rise to a considerable height through basement walls by the same cause, and the marks may be seen in all damp houses. This capillary action is explained by the theory of the existence of a surface tension, instanced by the experiment of placing carefully a fine steel needle on the surface of water; it will sometimes float, apparently supported by a thin membrane in tension, which bends under the weight of the needle.

Experiment has led to the formulating of two laws relating thereto:—

1. At the bounding surface separating air from any liquid, or between two liquids which do not mix, there is a surface tension similar to that of a membrane, which is the same at every point and in every direction.

2. At the line of junction of the bounding surface of a gas and a liquid with a solid body, or of the bounding surface of two liquids with a solid body, the surface is



inclined to the surface of the solid body at a definite angle depending on the nature of the solid and the liquids.

Of all common liquids water possesses the greatest degree of surface tension.

When a liquid and a solid surface meet, the particles on both margin surfaces are not attracted equally on all sides, while the particles in the interior of the liquid and solid are subject to equal attraction on all sides, being quite surrounded by the same media. A surface tension thus arises in the surface, separating the liquid and the solid, caused by the interaction of the molecular forces at the free surfaces.

When a liquid wets a solid the effects produced are caused by an attraction between the solid and the liquid. When a liquid does not wet a solid the effects are caused by a repulsion between them.

For instance, if in a capillary glass tube the surface of glass be greased so as not to be wet by the water in which it is plunged, the result will resemble those which occur when it is plunged in mercury. Mercury does not wet or cling to the surface of glass. When capillary tubes are plunged in liquid the liquid is raised or depressed, according as it wets or does not wet the surface. The elevation or depression varies inversely as the diameter of the tube; it also varies with the temperature and the nature of the liquid, but is independent of the thickness of the tube.

In Steam Heating apparatus it is generally supposed that the water condensed from the steam flows back to the boiler along the invert of the pipe, whereas the fact is it clings by capillary attraction all round the perimeter of the pipe, and is strongly affected by the flowing current of the steam, sometimes causing the noise heard in steam-heating pipes. This is a practical point worth knowing.

Hydrostatics, hydraulics, and aerometry are branches of science which ought to be studied by all plumbers.

Hydrostatics teaches concerning the equilibrium and pressure of liquid and gaseous fluids.

Hydraulics teaches concerning the laws and phenomena of incompressible fluids in motion, especially of water.

Aerometry teaches concerning the laws and phenomena of compressible or elastic fluids, especially of air.

Many of the works undertaken by plumbers depend for proper construction and proportion upon calculations founded on the laws which regulate the pressure, weight, and motion of fluids—in such works, for instance, as water supply, storage, and distribution, sewerage, drainage, heating, lighting, ventilation, water and steam power.

The universe is composed, so far as we know, of minute atoms of matter, which have been classified or separated into three great divisions or states—solid, liquid, and gaseous. The plumber has to do with each in turn, and is personally concerned in the laws which govern them.

When minute particles of matter are joined in a condition that requires considerable force to separate or disturb them the matter is then *solid*, such as steel, lead, wood—steel being the most perfect solid of the three named. When minute particles of matter are joined in a condition so that the smallest force causes them to move upon, under, and among each other, and to change their positions with perfect facility, the matter is then *liquid*, such as alcohol, water, oil, mercury—alcohol being the most perfect liquid of the four named, water being of the most concern to plumbers. When minute particles of matter are joined in a condition so that they expand without limit if freed from restraint, and contract without limit if pressure is applied; when heat powerfully tends to expand, and cold to contract them, the matter is then *gaseous*, such as air, steam, oxygen—air being the principal gaseous fluid of those named.

Solids in minute division, such as sand, sawdust, borings,



appear to possess some of the mobile qualities of liquids, but each grain of the mass is yet a perfect solid, formed of many very minute particles or molecules. Liquids are called incompressible fluids. The effect of the greatest possible pressure upon them is practically inappreciable—only to be detected by minutely accurate scientific measurement. Gases are called compressible or elastic fluids, for their volume expands and contracts without limit. It is even understood that some marvellously attenuated gas or ether fills the vast spaces to the distant stars, capable of bearing or of causing the minute vibrations which produce the sensation of light, enabling us to see the light of these stars so many millions of millions of miles away, that no man can ever count the measure or conceive the distance.

Liquids may be changed into solids and into gases. Water may be frozen into solid ice or boiled into steam. Lead may be melted by heat or evaporated to vapour.

In hydrostatics the fundamental principle which concerns us as hydraulic engineers and plumbers is the equal transmission of pressure in liquids. The results of this action are met in practice every day.

The discovery of the principle is due to Pascal, who was born at Auvergne, in France, in 1623.

If a closed vessel, any size or form, be filled with water, and the water be subjected to any pressure at any given point, that identical amount of pressure will be transmitted, equally, undivided, and at right angles, to every point of the liquid and of the internal surface of the vessel.

For instance, if a closed hot-water cylinder, say 2 feet diameter  $\times$  3 ft. 6 in. long, containing about 4,000 square inches of internal superficial area, be filled with water, and a small pipe of one square inch area be connected to it at any point, and a pressure of 21 lbs. on that square inch be applied,

either by pumping or by a vertical column or head of water 50 feet high, a pressure of 21 lbs. will be transmitted, at right angles, to each and every separate square inch of the 4,000 square inches of the internal surface of the cylinder, pressing up against the top, down against the bottom, and radiating as from the centre against the sides; so that, as there are 4,000 square inches of inner surface, the total pressure exerted against them will be 84,000 lbs. or nearly 38 tons. If we were ignorant of this law we might naturally suppose that, if a pressure of 21 lbs. was applied to the pipe, that pressure of 21 lbs. would be divided equally against each square inch of internal surface, and that the total pressure on the cylinder would be 21 lbs., instead of  $21 \text{ lbs.} \times 4,000 = 84,000 \text{ lbs.}$ !

We may see the difference here between the action of liquids and solids, for conceive the column of one square

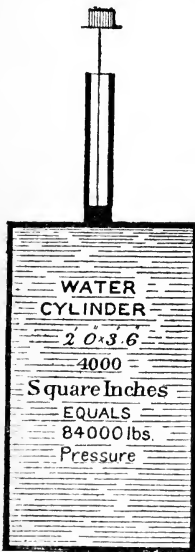

inch of water as frozen solid, or imagine that a solid rod of wood, one inch square, was pressed in, instead of the water, of course allowing an equal bulk of the water in the vessel to escape, and that either the ice column or the wood column was pressed by a force of 21 lbs.; giving the same pressure as the liquid column gave, the only effect produced is that these solid columns will transmit 21 lbs. of pressure to *the* one square inch of surface on which they rest and press, and they do not influence or transmit pressure to any other part of the cylinder.

In this illustration we omit altogether, for convenience and clearness, the differences of pressure on the top and bottom and sides due to the difference of the

FIG. 4.—Water Cylinder under pressure.

height of the column of water acting on each different level of the cylinder.

If this iron cylinder had been made only just strong enough to contain the water it holds it should burst long before the pressure of 38 tons extra was applied. This 50-foot head is not an uncommon pressure for plumbers to find necessary to apply to hot-water cylinders and boilers. Pascal discovered the fact that, by filling a barrel with water and inserting a high tube of very small diameter into the bung-hole of the barrel, a very small additional quantity of water poured down the tube bursts the barrel. The sides of the barrel have to bear, on each square inch, the same pressure as though they had been surmounted by a column of water of the same diameter as the whole internal superficial area of the barrel itself. The hydrostatic paradox that a quantity of water, however small, may be made to support a weight, however large, is due to this principle discovered by Pascal in his experiment.

The square inch, as the standard unit area in England, is chosen for its convenience only; as there are 144 square inches in a square foot, we find the total pressure of a column of water on a square foot by multiplying the pressure on one square inch by 144.

If the bottom of a cistern 3 feet  $\times$  12 feet has to support 7 feet depth of water the pressure on each square inch will be 3 lbs.; how many pounds pressure has the whole bottom to bear, and how many pounds per square foot?

$$3 \text{ ft.} \times 12 \text{ ft.} = 36 \text{ sq. ft.} \times 144 = 5,184 \text{ sq. in.} \times 3 \text{ lbs.} = 15,552 \text{ lbs. pressure on the whole surface of bottom.}$$

$$3 \text{ lbs.} \times 144 \text{ sq. in.} = 432 \text{ lbs. pressure per square foot.}$$

If the bottom of a hot-water cylinder, 24 inches diameter, has to bear a pressure of 18 lbs. per square inch, due to

42 feet column of water, how much has the whole bottom to bear, and how much per square foot?

$$24 \times 24 = 576 \times .7854 = 452.39 \text{ sq. in.} \times 18 \text{ lbs.} = 8,143 \text{ lbs.}$$

pressure on the whole bottom.

$$18 \text{ lbs.} \times 144 \text{ sq. in.} = 2,592 \text{ lbs. pressure per square foot.}$$

Another important hydrostatic law for plumbers to bear in mind is that the pressure on each square inch of surface at different depths in any liquid, is equal to the weight of a column of the liquid, whose base is the square inch; that pressure is always transmitted equally in every direction round every point in the liquid at the given depth.

For instance, let us take a 20-gallon vessel full of water, 3 ft. 6 in. deep, and immerse in it an open-ended tube of one square inch area, and 3 ft. 6 in. long, standing on and in water-tight contact with the bottom.

The pressure of water on the particular square inch of cistern at the bottom of the tube will be  $1\frac{1}{2}$  lbs., or the pressure due to the 3 ft. 6 in. column of water above it. Remove the tube and the pressure will remain precisely the same on that particular square inch, although now the whole body of water in the cistern is in direct contact with and above it.

Mark the tube across into three equal divisions, and the pressure at the bottom, *a*, will be  $1\frac{1}{2}$  lbs. per square inch in every direction inside and outside of the tube, due to the column of water above that point. At the first mark, *b*, it will be 1 lb. in every direction inside and outside of the tube, due to the column of water above the point *b*; a gauge screwed into the side of the cistern at the same level will indicate 1 lb. pressure. At the second mark, *c*, the pressure will be reduced to  $\frac{1}{2}$  lb. per square inch in every direction inside and outside of the tube, due to the reduced

column of water above the point *c*, and of course a gauge screwed into the side of the cistern at the same level will also indicate  $\frac{1}{2}$  lb. pressure. At the third mark, *d*, the pressure will be 0, due to there being no column of water above. There is, of course, the atmospheric pressure of about 15 lbs. per square inch above all these water pressures and acting along with each, but in practice it is omitted in such calculations, being equal in all.

The overflow stand-pipes of tanks are subject to the same pressure per square inch as are the sides of the tanks at the

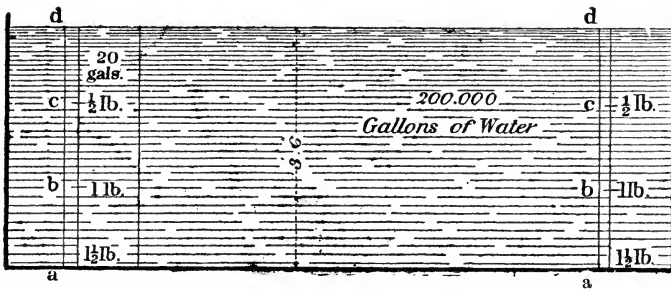

FIG. 5.—Water pressure in cisterns.

same levels, and they should be formed of sufficiently strong material.

Let us now increase the dimensions of the 20-gallon vessel to 200,000 gallons, but without increasing the height of the water level, and we shall find that the pressures shown on each square inch at the various depths will remain the same as in the 20-gallon vessel, the pressure on each point being due to the vertical column of water above it alone, and not in any way to the mass of water around or on each side.

Owing to ignorance of this simple law it has happened over and over again that plumbers, in trying to prevent a repetition of bursts on lead water-pipes originally fixed of too light material, have reduced the bulk of water in the

tank by placing a division across it without lowering the level of the water surface, and in trying to gain additional pressure on distributing pipes they have increased the size of the tank without raising the level of the water surface, no change of pressure resulting in either case.

Each foot of vertical height added to a column of water by raising a feed-tank to a higher level, or by raising the sides of the tank and filling it, adds an increase of  $\cdot4335$  lbs. per square inch to the effective pressure. This is roughly taken by plumbers at  $\frac{1}{2}$  lb. pressure for each foot in height, and for pressure on pumps in working this estimate allows a fair margin for friction losses; but to be more accurate and yet not too abstruse, it is a good and easy rule to calculate 3 lbs. pressure per square inch for every 7 feet in height of water. Thus 14 feet gives 6 lbs. pressure, 21 feet gives 9 lbs. pressure, 28 feet gives 12 lbs. pressure, 35 feet gives 15 lbs. pressure, 42 feet gives 18 lbs. pressure, 49 feet gives 21 lbs. pressure, and so on.

An important law of hydrostatics, due to the perfect mobility of the minute particles of liquids, is that when water has a free surface that surface will be horizontal, *i.e.* at right angles to the direction of the force of gravity; as illustrated by the letter T, the horizontal line being the free surface of the water, the perpendicular line being the direction of the force of gravity.

A temporary suspension of this law of nature, called a miracle, must have been wrought in order to cause the waters of the Red Sea and Jordan River to stand as a wall on the right hand and on the left while the Israelites passed over dryshod.

When the free surface of water is subject to any other forces beside the force of gravity, the surface must at every point be at right angles to the resultant of the forces acting on that point.

The sloping surface of the waves of ocean, for instance, is at every point of that surface at right angles to the resultant or combined action of the force of gravity in one direction, and of the force of the wind in another direction.

If an open vessel of water is rapidly revolved, you may observe that the curve assumed by the surface of the water is regulated by the same law, each point of surface taking right angles to the resultant or combination of the force of gravity acting in one direction and centrifugal force acting in another direction. The curve formed by the surface of water flowing from any orifice or over any weir is subject to and regulated by the same law, but is treated under the head of hydraulics. Likewise the motion of water or sewage through pipes or drains is under the same influence.

The surface of any liquid of equal density throughout, and at rest, is therefore a horizontal plane, as the surface of a pond. Plumbers especially need to remember that water ever presses to attain this horizontal level in every part of a system of connected pipes and cisterns. The water in a reservoir, say, 105 feet high over a town, though many miles distant, is ever pressing on the whole internal surface of the water-mains and distributing service-pipes, on every square inch and at every point of that service, in an endeavour to attain the same level already possessed by the water in the reservoir.

Men might take example by this, and endeavour to raise each other up to a higher level of knowledge and skill.

This effort of the water is the pressure which we measure as acting on each square inch, 3 lbs. per square inch for every 7 feet in height of head.

With the reservoir 105 feet high, then 7 feet divided into 105 equals 15; this multiplied by 3 lbs. is equal to 45 lbs. pressure due on every square inch at the depth of 105 feet below the surface when the water is at rest. This

pressure in practice, when motion is caused by water being drawn off, will be quite seriously reduced; in some parts of a long or badly adjusted system of pipes it will be reduced almost to nothing by the effect of friction due to the different lengths and sizes of the pipes.

If, however, we suppose every pipe-end in the city closed, no water being drawn off, as sometimes occurs in the dead of night in towns, with the water in the reservoir turned on from the high level of 105 feet; then if we suppose 100 pressure-gauges be screwed on 100 different points of

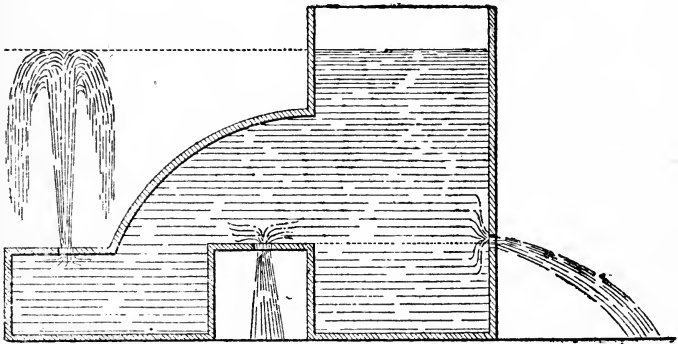

FIG. 6.—Equal velocity outlets.

the mains and service-pipes, large and small, but all the points being at the one level, 105 feet below the surface of the water in the reservoir, all the gauges, near and distant, would indicate a pressure equally of 45 lbs. per square inch.

Or if we suppose 100 vertical tubes, 106 feet high, and of any diameters from 1 inch to 100 feet, screwed into the water-pipes at the various points beside the 100 pressure-gauges, the water would steadily rise in all these 100 tubes, until the surface in each tube reached the level of 105 feet, provided that the level of the water in the reservoir be maintained at the original level of 105 feet.

Or if we suppose these tubes to be only 50 feet high



and open at top, then the water would overflow and pass away first from those tubes in which the retarding friction of the pipe surface would have least effect.

In the diagram on p. 52 three outlets are shown at one level under one head of pressure; the water issues from each outlet at the same velocity, due to the head of water, whether discharging upwards, downwards, or horizontally.

In large mansions, where many cisterns are placed on various levels connected by pipes, it is essential, as every plumber knows, to provide valves to stop the flow of water when the low-level cisterns fill, and also in every case to provide safety overflow pipes, to act in event of the stop-

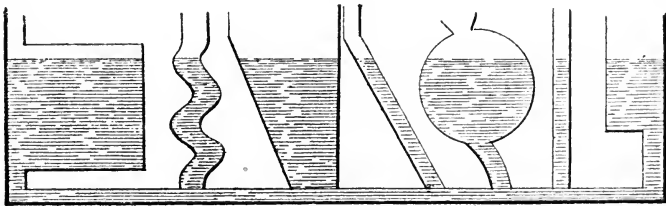

FIG. 7.—Water in horizontal plane.

valves failing to close. Sometimes two or more large main tanks are placed on one high level in opposite ends of the mansion, all being filled through connecting pipes from one tank nearest the source of supply; the law we have been considering governs all these arrangements, and disaster follows whenever that law is violated or neglected.

“The surface of a liquid of equal density at rest in connected vessels is a horizontal plane.”

There is another point which plumbers require to note. Sometimes an open hot-water cistern and pipes, connected with a cold-water cistern and pipes, are fixed on the same level. The density of cold water being greater than the density of hot water, which latter expands and becomes

lighter by the action of heat, the level of the surface of the hot water in the hot cistern stands higher than the level of the cold water in the cold cistern, this difference increasing as the difference in temperature increases, and therefore in such case the surface is not maintained in a horizontal plane, because the hot and cold liquids are of unequal density. The instant the outer action of heat ceases the densities equalise, and the levels of the surfaces also equalise into one horizontal plane. The practical lesson for plumbers, derived from a knowledge of this apparent deviation from a fixed law, is this: to be careful to provide that the top of the hot cistern shall be so much higher than the level of the surface of water in the cold-water cistern, to allow room for this expansion of the water when heated. Water will expand  $\frac{1}{5}$ th of its bulk when heated from  $39^{\circ}$  to  $212^{\circ}$ ; therefore 25 gallons of cold water increase to 26 gallons at  $212^{\circ}$ , 50 gallons increase to 52 gallons, 100 gallons to 104 gallons.

The overflow outlet of the hot-water cistern should not be arranged to check and carry off this rise of water level, because obviously the hot water would then flow constantly away to waste. This frequently occurs in bath-room arrangements.

Ample space for free expansion should be provided between the surface of the water, when cold, and the safety overflow in the cistern, by providing the cisterns of sufficient height, and by regulating the level of the water in the cold-water cistern permanently at a sufficient depth below the safety overflow outlets. To illustrate further the point under consideration, let us take a vertical U-shaped glass tube, and let us take two liquids which do not mingle together, of different densities or specific gravities, such as cold water and mercury; let us pour the mercury into one

end of the tube and the water into the other, and it will be seen at once that the heights of the upper surface of the two liquids vary. In fact, the heights of the upper surfaces vary in inverse proportion to their densities; the water being of lesser density, its upper surface rises to a greater height, and the mercury being of greater density, its upper surface rises to a lesser height, in exact proportion to the difference of their densities.

A cubic inch of mercury, being  $13\frac{1}{2}$  times denser than water, will fall to  $13\frac{1}{2}$  times below the surface of the water in the tube, when it will be found exactly to balance in equilibrium a cubic inch of water. A cubic inch of water, being  $13\frac{1}{2}$  times less dense than mercury, will rise  $13\frac{1}{2}$  times higher at the upper surface in the tube than a cubic inch of mercury before equilibrium is established.

The hydrostatic law, then, is—

“That if two liquids that do not mingle together meet in a bent vertical tube, the heights of their upper surfaces above their common surfaces will be inversely proportional to their densities.”

In a perfectly horizontal drain a shallow layer of water tends to rest with its surface at right angles to the direction of the force of gravity, but it acquires motion by the force of gravity affecting the mobile outer particles, which fall or are spread out right and left, causing a momentary slope or divergence in the horizontal surface; then the imperceptibly higher particles instantly, in obedience to the law, move downward, so as to regain the level, and maintain the surface at right angles to the direction of the force of gravity.

When the drain or the surface of the water is raised at one end movement takes place; the more the surface is diverted from the level the more haste does the liquid use to regain the level.

This velocity would accelerate constantly if no retarding force existed to check it; but it has been found—for instance, by forming a wooden-trough channel several hundred feet long, with a fall of 1 in 10, and causing water to flow through it freely—that, after the first hundred feet, the force of friction constantly acting so regulated the tendency of the water-flow to acceleration that the rate of flow thence onward was uniform. The two forces are, therefore, found to be equal.

The resistance of surface or friction in the case of fluids is independent of the pressure or head, the amount being the same whether the head be ten or fifty feet. The result is exactly opposite to this in the case of solids; friction is directly proportioned to the pressure of one solid upon another.

Friction in fluids is dependent on the *extent* of surface exposed to the flow, and the greater the volume of fluid in proportion to the retarding surface the less reduction will be in the velocity; but on solid surfaces the friction is independent of the amount of surface pressed upon, if the pressure on the whole of the greater or lesser surface be the same.

The layers of fluid nearest the solid surface are the most retarded by friction, these fluid layers retarding less and less those inside them, so that the water least affected by friction, and therefore having the greatest velocity, is that portion flowing furthest from the solid bottom and sides of a channel, and furthest from the solid interior surface of a pipe.

The resistance or friction in the case of fluids in contact with solids is proportional to the square of the velocity nearly; the greater the velocity the greater the resistance offered. Exactly opposite to this is the case with solids in contact with solids, whose friction is independent of velocity.

Whether the velocity be great or small, the friction remains the same.

It is odd that, in this branch of science, the term "friction" is applied to the resistance offered to fluids in motion by the solid surface they pass over, while the same term has almost an opposite signification as applied to solids in motion in contact with solids.

These laws of friction teach us that a circular form of pipe is best for the *constant full* discharge of water or sewage, the resistance being independent of the head of pressure, proportional to the square of the velocity and to the surface in contact with the water.

A circular pipe, having the same area as a square pipe, will deliver more water under the same head of pressure in a given time. The greatest discharge of water through a circular section pipe, when the head is due only to the rate of inclination, will be not when the pipe flows full, but when it is filled only nineteen-twentieths of its diameter, the wetted perimeter being  $308^\circ$ , and therefore the supplemental arc  $52^\circ$ . The velocity is also greater, proportionally, than the actual discharge. The velocity of the water passing through a section of greatest hydraulic mean depth exceeds the velocity in a pipe running full by ten per cent. The scouring power will, therefore, be increased in drains and sewers and other circular pipes by arranging them to run at greatest hydraulic mean depth.

Water flowing from iron cisterns might be expected to flow quicker through a hole in the thin iron side than through a short added tube, but this is not found to be so. The water, instead of flowing to the hole and out in a parallel cylindrical form, is found to become contracted by the force of the converging layers of water, so that, supposing a hole made one inch in diameter, the issuing stream takes the shape of a cone, and becomes  $\cdot784$  inch in

diameter at a distance of about half the diameter, or half an inch in this case from the aperture, showing a curve of about one and a quarter of the diameter of the aperture. This is called *vena contracta*. Taking the actual diameter of the orifice in the side or bottom of a cistern, the theoretical velocity of efflux would be that due to the head of water in the cistern, and is that of a body falling in vacuo from that

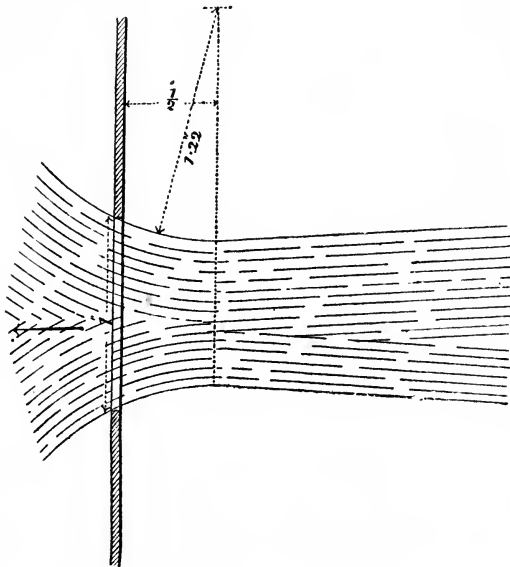

FIG. 8.—The vena contracta.

height. In all calculations the head is measured from the surface of the water to the centre of the orifice when the orifice is not under water; therefore the square root of the head of water in feet, multiplied by 8, will give the theoretical velocity of efflux. If the head be 16 feet, then  $\sqrt{16} = 4$ , and  $4 \times 8 = 32$  ft. per second = theoretical velocity of discharge. Velocity =  $\sqrt{\text{head}} \times 8$ , and the theoretical discharge in gallons per minute can be found by multiply-

ing the square root of the head in feet by the square of the diameter in inches, and the product by 16·3. Discharge in gallons =  $\sqrt{\text{head}} \times \text{diameter}^2 \times 16\cdot3$ . With 16 ft. head and 2 in. diameter,  $\sqrt{16 \text{ ft.}} = 4$ ;  $4 \times 2^2 = 4 \times 4 = 16$ ;  $16 \times 16\cdot3 = 260\cdot8 =$  theoretical discharge in gallons per minute. The actual velocity and discharge is found by applying this rule, not to the dimensions of the actual orifice, but to the known dimensions of the narrowest section of the vena contracta, which we have seen is ·784 of the orifice.

The square of 1 to the square of ·784 equals 1 to ·615 or ·62 nearly. To find the actual velocity of efflux in feet per second through any circular orifice in a thin plate multiply the square root of the head of water in feet by 8, and the product by ·615 or ·62. To find the actual discharge in gallons per minute Box gives the rule—Multiply the square root of the head of water in feet by the square of the diameter of the orifice in inches, and multiply the product by the constant number or co-efficient 10.

When the plate through which water issues is thick we find an increased delivery of water. Compare this diagram with the vena contracta diagram of the thin plate.

If a short tube be added, not less in length than three times the diameter of the orifice, a further gain is obtained, which may be calculated by substituting the number 13 for 10 in the preceding rules for thin plate orifices.

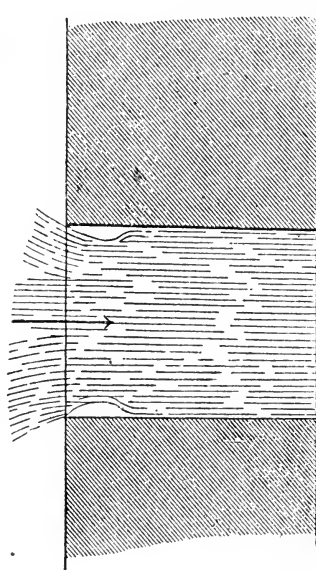

FIG. 9.—Efflux through thick plate or wall.

The existence of the vacuum caused by the outflow of water in the tube can be shown by adding a short tube, as in the diagram (Fig. 11), and placing a cup full of water under the end. When the water is flowing under a good head from the cistern a column of water will rise in the added tube, as in the diagram.

Through conical tubes or adjutages the efflux is further increased, and the full effect, or nearly the theoretical

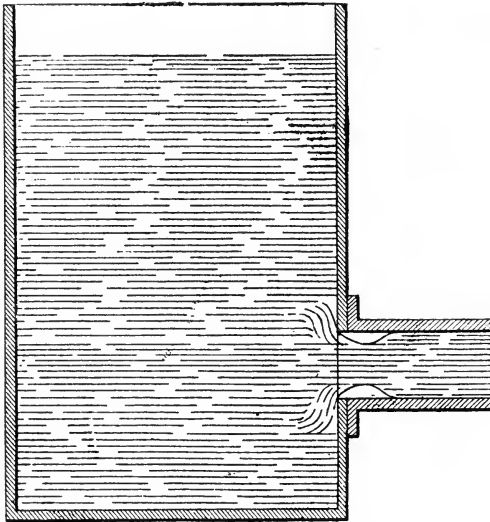

FIG. 10.—Short tube adjutage.

delivery, can be obtained when the natural form of the vena contracta is given to the adjutage, and even a greater delivery than the theoretical amount may be gained by the use of the modified conical elongated form of adjutage, specially recommended from actual experiment by Venturi.

The effect of the shape of the orifice is not marked when the water has to pass through long pipes, but it is well to give the best shape to the entry in all cases, when possible.



Torricelli gave us this formula two hundred years ago,  $\sqrt{2gH} = V$ , easily remembered, and meaning—Multiply the head of water in feet, represented by  $H$ , by 32.2 (which we know is the constant dynamical measure of the force of gravity represented by  $g$ ), multiply this product by 2, and

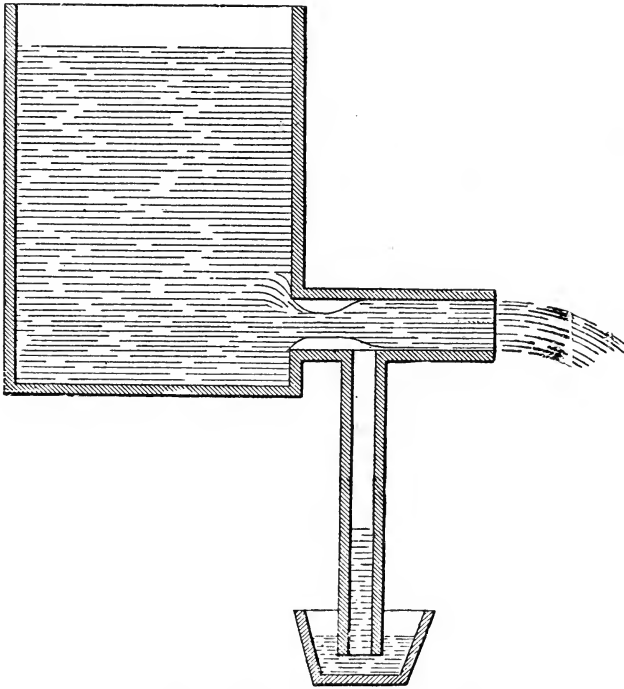

FIG. 11.—Vacuum proof experiment.

find the square root. The result gives the velocity in feet per second. Experiment has proved that only  $\frac{62}{100}$ ths, or .62 of the efflux calculated from this theorem is actually discharged through a hole in a thin plate.

If a cistern 16 feet deep have a hole opened in the bottom we apply the formula  $\sqrt{2gH}$  thus:  $2 \times 32.2 \times 16 = 1,030$ ;  $\sqrt{1,030} = 32$  ft. nearly, theoretical velocity in feet per second

a result which corresponds to the velocity at the end of one second of any substance falling 16 feet freely in vacuo on the earth's surface. Having ascertained the theoretical velocity, to find the quantity of water discharged through any given orifice (fitted with a tube in shape of vena contracta), multiply the velocity in feet per second by the narrowest area of the orifice in square feet, and the result gives the quantity discharged in cubic feet per second. Multiply this by 6.3 for gallons per second.

As before explained, this result will be much modified by the form of the delivery opening or adjutage. Venturi has experimented with a conical adjutage, which, he states, gives a real discharge 2.4 times greater than will an orifice in a thin plate, and 1.46 times greater than the theoretic discharge. This form has a length nine times greater than the diameter of smaller base, and an angle of divergence  $5^{\circ} 6'$ .

#### PRACTICAL RULES FOR HYDRAULIC ENGINEERS AND PLUMBERS.

1. To find ( $V^x$ ), the theoretical velocity of water in feet per second issuing from an orifice in the side of any vessel with any given head of water pressure, multiply the square root of the head of water in feet ( $H$ ) by the constant number 8—

$$V^x = \sqrt{H} \times 8.$$

Thus, from any orifice with two feet head of pressure, the theoretical velocity ( $V^x$ ) is—

$$V^x = \sqrt{2} \times 8 = 1.41421 \times 8 = 11.3 \text{ feet per second.}$$

2. To find ( $G^x$ ), the theoretical discharge of water in gallons per minute issuing through any given circular orifice in the side of any vessel with any given head of water ( $H$ ), multiply the square root of ( $H$ ), the head of

water in feet, by the square of ( $d$ ), the diameter of the circular orifice in inches, and multiply the product by the constant number 16—

$$G^x = \sqrt{H} \times d^2 \times 16.$$

Thus, with two feet head of water and a circular orifice of three inches, the theoretical discharge ( $G^x$ ) is—

$$G^x = \sqrt{2} \times 3^2 \times 16 = 1.41421 \times 9 \times 16 = 203 \text{ gallons per minute};$$

or, with nine feet head of water and a circular orifice of two inches, the theoretical discharge ( $G^x$ ) is—

$$G^x = \sqrt{9} \times 2^2 \times 16 = 3 \times 4 \times 16 = 192 \text{ gallons per minute.}$$

These rules give the theoretical velocity and discharge due to force of gravity; the actual velocities and discharges are found by modified rules.

3. To find ( $V$ ), the *actual* velocity of water in feet per second issuing from an orifice in a thin plate, as in an iron cistern, reduce the theoretical velocity by multiplying it by .62—

$$V = V^x \times .62, \text{ or } \sqrt{H} \times 8 \times .62.$$

Thus, from any orifice with two feet head of pressure, the actual velocity ( $V$ ) is—

$$V = \sqrt{2} \times 8 \times .62, \text{ or } 1.41421 \times 8 \times .62 = 7.014, \text{ or } 7 \text{ feet per second.}$$

4. To find ( $G$ ), the *actual* discharge of water in gallons per minute issuing from any given circular orifice in a thin plate, as in an iron cistern, reduce the theoretical discharge by multiplying it by .62—

$$G = G^x \times .62, \text{ or } \sqrt{H} \times d^2 \times 16 \times .62.$$

Or, by a simpler formula used by Box, multiply the square root of ( $H$ ), the head of water in feet, by the square of ( $d$ )

the diameter of the orifice in inches, and multiply the product by the constant number 10—

$$\text{Box's formula: } G = \sqrt{H} \times d^2 \times 10.$$

Thus, with two feet head of water and a circular orifice of three inches, the actual discharge (G) is—

$$G = \sqrt{2} \times 3^2 \times 10, \text{ or } 1.41421 \times 9 \times 10 = 127 \text{ gallons per minute;}$$

or, with nine feet head of water and a circular orifice of two inches, the actual discharge (G) is—

$$G = \sqrt{9} \times 2^2 \times 10, \text{ or } 3 \times 4 \times 10 = 120 \text{ gallons per minute.}$$

5. To find (H), the head of water necessary in order to discharge any given number of gallons per minute through any given circular orifice in a thin plate, as in an iron cistern, multiply the square of (*d*), the given diameter of the orifice in inches, by the constant number 10, and divide the product into (G), the given number of gallons per minute, and square the quotient—

$$\text{Box's formula: } H = \left( \frac{G}{d^2 \times 10} \right)^2.$$

Thus, to pass 127 gallons of water through a 3-inch circular orifice, the required head (H) is—

$$H = \left( \frac{127}{3^2 \times 10} \right)^2, \text{ or } \left( \frac{127}{9 \times 10} \right)^2 = 1.988, \text{ or nearly 2 feet.}$$

6. To find (*d*), the diameter in inches of a circular orifice in a thin plate necessary in order to discharge any given number of gallons of water per minute with any given head of water in feet, multiply the square root of the given head of water in feet by the constant number 10, and divide the product into the given number of gallons per minute, and find the square root of the quotient—

$$\text{Box's formula: } d = \left( \frac{G}{\sqrt{H} \times 10} \right)^{\frac{1}{2}}.$$

Thus, under two feet head of water, to pass 127 gallons per minute, the required diameter ( $d$ ) is—

$$d = \left( \frac{127}{\sqrt{2} \times 10} \right)^{\frac{1}{2}}, \text{ or } \left( \frac{127}{1.41421 \times 10} \right)^{\frac{1}{2}} = 3 \text{ inches nearly.}$$

7. To find (G), the *actual* discharge of water in gallons per minute issuing from any given circular orifice fitted with a short tube not less in length than thrice the diameter, multiply the square root of (H), the head of water in feet, by the square of ( $d$ ), the diameter of the orifice in inches, and multiply the product by the constant number 13—

$$\text{Box's formula: } G = \sqrt{H} \times d^2 \times 13.$$

8. To find (H), the head of water necessary in order to discharge any given number of gallons per minute through any given circular orifice fitted with a short tube not less in length than thrice the diameter, multiply the square of ( $d$ ), the given diameter of the orifice in inches, by the constant number 13, and divide the product into (G), the given number of gallons per minute, and square the quotient.

$$\text{Box's formula: } H = \left( \frac{G}{d^2 \times 13} \right)^2.$$

9. To find ( $d$ ), the diameter in inches of a circular orifice fitted with a short tube not less in length than thrice the diameter necessary in order to discharge any given number of gallons of water per minute with any given head of water in feet, multiply the square root of the given head of water in feet by the constant number 13, and divide the product into the given number of gallons per minute, and find the square root of the quotient—

$$\text{Box's formula: } d = \left( \frac{G}{\sqrt{H} \times 13} \right)^{\frac{1}{2}}.$$

Rules 7, 8, and 9 are identical with rules 4, 5, and 6, except as regards the constant number employed.

In order to find the weight of water flowing from an orifice in the side of a cistern in a given time, multiply the velocity of efflux in seconds, as found by Torricelli's theorem,  $\sqrt{2gH}$ , by the time, multiply the product by the weight of a cubic inch of water, 252.458 grains, and multiply this product by the cross-section of the orifice in square inches. The final product gives the weight in grains, theoretically due to Torricelli's theorem; but hydraulic engineers know that, owing to the form taken by the water in issuing from this kind of orifice, the real section area of the jet at its narrowest point is  $\frac{62}{100}$ ths of the section area of the orifice, and that, therefore, only  $\frac{62}{100}$ ths of the quantity of the theoretical efflux will be in fact discharged.

They substitute in their calculations the smallest cross-section area of the vena contracta for the cross-section area of the orifice, and thus secure a rule which holds good in practice, viz. multiply the theoretical result above by .62, for the actual result agreeing with actual experiment and practice.

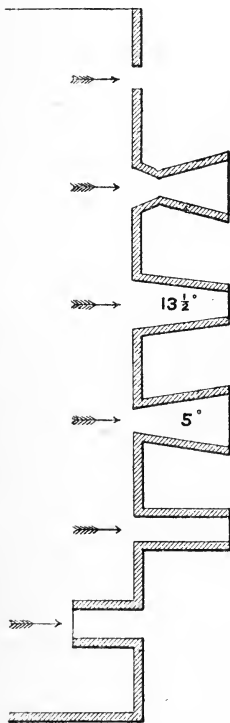

FIG. 12.—Various orifices.

To sum up these matters, we find that the actual discharge from any orifice in a thin plate, as the side or bottom of an iron cistern, is only 62 per cent. of the theoretical discharge, viz. 62 gallons, instead of 100 gallons.

If a short cylindrical tube, in length three times the diameter of the orifice, be added, the discharge increases to 82 per cent. of the theoretical discharge, viz. 82 gallons, instead of 100

gallons. If the added tube be made in the shape assumed by the water in vena contracta the discharge increases to 92 per cent. of the theoretical discharge, viz. 92 gallons actual for every 100 theoretical; and when Venturi's inverted nozzle is used the discharge exceeds the theoretical by 25 per cent., or 125 gallons actual for every 100 gallons theoretical.

To find the time required to fill any tank when water is flowing in and out at the same time, deduct the number of cubic feet flowing out per minute from the number of cubic feet flowing in per minute, and divide the remainder into the contents of tank in cubic feet, and the quotient gives the number of minutes required for the tank to fill.

Thus, if ten cubic feet are flowing in and three cubic feet are flowing out per minute of a tank 12 feet  $\times$  10 feet  $\times$  6 feet, containing 720 cubic feet—

$$\frac{720}{10-3} = 103 \text{ minutes required to fill the tank.}$$

To find the time required to empty any tank when water is flowing in and out at the same time, deduct the number of cubic feet flowing in per minute from the number of cubic feet flowing out per minute, and divide the remainder into the contents of the tank in cubic feet, and the quotient gives the number of minutes required to empty the tank.

Thus, if six cubic feet are flowing in and eight cubic feet are flowing out, the tank starting full, being 9 feet  $\times$  6 feet  $\times$  3 feet, containing 162 cubic feet—

$$\frac{162}{8-6} = 81 \text{ minutes required to empty the tank.}$$

The amount flowing out must be measured or calculated when the tank is half full, as the delivery will be greatest





To find the contents of a cylindrical water cistern in gallons approximately, square the diameter in feet, multiply by 5, and the product by the depth in feet.

Thus, a cylindrical tank 2 feet diameter by 3 feet deep—

$$2 \times 2 \times 5 \times 3 = 60 \text{ gallons contents approximately.}$$

The ordinary rule is to multiply the diameter squared in feet by .7854, and the product by the depth in feet, and this again by 6.23 for gallons, which in the case given would be—

$$2 \times 2 \times .7854 \times 3 \times 6.23 = 58.716504 \text{ gallons exactly.}$$

To find the pressure in pounds per square inch under any given head of water, multiply the head in feet by .433; or, by another rule, divide the head in feet by 7, and multiply the quotient by 3, and add  $\frac{1}{100}$ th part where great accuracy is required.

Thus, at the bottom of a pipe 130 feet high—

$$130 \times .433 = 56.29 \text{ lbs. pressure per square inch,}$$

or—

$$130 \div 7 = 18.57 \times 3 = 55.7 \text{ lbs. pressure approximately,}$$

adding  $\frac{1}{100}$ th for correctness = 56.257 lbs. exactly.

To find the resistance against the plunger of a pump in motion it is usual to make allowance for friction of valves, etc., and to take half the height in feet of the rising main to equal the pressure in pounds per square inch on the plunger. Thus, in raising water 50 feet, the pressure is calculated as 25 lbs. per square inch on the plunger of the pump. Multiply this by the area of the plunger or of the cylinder in inches for the total pressure in pounds. A 3-inch pump has 7.068 inches area; therefore total pressure under 50 feet =  $176\frac{1}{2}$  lbs.

To find the head of water producing any given pressure, multiply the pressure in pounds per square inch by 2.31.

Thus, with 56.29 lbs. per square inch pressure—

$$56.29 \times 2.31 = 130.0299 \text{ feet head.}$$

To find the weight of water in one yard length of any cylindrical pipe approximately, square the diameter in inches.

Thus, in one yard of 6-inch pipe—

$$6^2 = 6 \times 6 = 36 \text{ lbs. weight.}$$

To find the contents in one yard length of any cylindrical pipe approximately, square the diameter in inches and divide by 10.

Thus, in one yard of 6-inch pipe—

$$6^2 = 6 \times 6 = 36 \div 10 = 3.6 \text{ gallons approximately.}$$

Plumbers constantly require to calculate the amount of water which will flow through long pipes of various diameters under various heads of pressure. The quantity discharged at the outlet of any pipe depends on the velocity of flow, and is affected materially by the length and diameter of the pipe, by the number and kind of bends or other changes of the direction of flow, and by the effective head of water, and in a slight degree by the shape of the entry or orifice.

The effect produced by the friction of the flowing water on the surface of the pipe or channel is so very great as to form the chief factor in hydraulic calculations for long pipes. It increases in a less ratio than the square of the velocity. If the velocity of the water be doubled the friction is increased nearly four times; if the velocity be increased three times the effect of friction is increased nearly nine times, and so on.

The velocity of water flowing through long pipes of any given diameter depends not on the inclination of any

particular length, but on the ratio between the head of water and the length of pipe, otherwise the hydraulic mean gradient. Except for the effect of friction at bends, velocity is independent of the direction of the pipes, whether laid at uniform gradient or not throughout its length, provided that the contour of the pipe is below the hydraulic mean gradient along the whole line. Velocity is also independent of the question whether the entry and outgo are at or below their respective upper and under surfaces, the measure of the head being taken from surface of water above to surface of water below, if not discharging freely in air.

The effective power of any head of water flowing through pipes is used or worked up under the two opposing forces. One is the initial check given to velocity at the entry irrespective of friction, and the other force is the constant check of friction alone along the whole length of the conduit.

The relative importance of these two factors in all hydraulic computations varies with the length and diameter of the pipe, the velocity and quantity of water discharged. For instance, in a pipe 8 inches in diameter, 10,000 feet long, discharging 300 gallons a minute, the relative value of the head necessary to overcome the check to velocity by friction, and the head to overcome the check to velocity at the entry, is as 40 feet to 2 inches. The relative importance of the two factors would be reversed in the case of the pipe being only 10 feet long.

Two feet head of water on an 8-inch pipe, 1,000 feet long, will yield a velocity of 1.79 feet per second, and discharge 234 gallons per minute.

Two feet head of water on an 8-inch pipe, 100 feet long, will yield a velocity of  $6\frac{1}{2}$  feet per second, and discharge 840 gallons per minute; 10 feet long, a velocity of 22 feet per second, and discharge 2,874 gallons per minute.

Eytelwein's rule for finding the delivery of water in pipes gives a somewhat lower result than these figures, and is as follows: Find the fifth power of the diameter of the pipe in inches; multiply it by the head of water in feet; divide the product by the length of pipe in feet, find the square root of the quotient, and multiply that by the constant number 4.71, which gives the cubic feet of water discharged per minute.

Hawksley's formula for the same result in practice is to multiply the diameter of the pipe in inches by the constant number 15, find the fifth power of the product and multiply by the head of water in feet, divide the product by the length of the pipe in yards, and find the square root of the quotient, which gives the number of gallons discharged per hour.

Neville's general formula to find the velocity in feet per second is to divide the head in feet by the length of pipe in feet, multiply the quotient by the hydraulic mean depth in feet, find the cube root of the product, and multiply this by the constant number 11; note the result. Now proceed to find the square root of the same product already ascertained, of which the cube root has been just taken, and multiply this by 140, and note the result. Deduct the lesser result noted from the greater, and the remainder is the velocity in feet per second.

Manning's formula, first published in December, 1889, provides a simple and accurate method of determining the mean velocity of the flow of water in open channels and pipes. It has been carefully tested and compared with the results obtained by actual experiment, and is here given by kind permission.

$$V = CS^{\frac{1}{2}} \left( R^{\frac{1}{2}} + \frac{R}{7} - .05 \right).$$

V represents the mean velocity in feet per second; C, a

co-efficient which varies with the nature of the conduit;  $S$ , the sine of the angle of inclination of the surface found by dividing the head in feet by the length of conduit in feet;  $R$ , the mean radius, or mean hydraulic depth, found by dividing the area of the section of water actually flowing by the length of the wetted perimeter.

The values of the co-efficients given are—

Old cast-iron pipes . . . .	85
New cast-iron pipes . . . .	114
New drawn-lead pipes . . . .	165

The formula is worked out as follows :—

Find the square root of the mean radius or mean hydraulic depth; divide the mean radius by the constant number 7, and add this quotient to the square root already found; deduct from this sum the decimal  $\cdot 05$ ; multiply the remainder by the co-efficient appertaining to the nature of the conduit in question, and multiply that product by the square root of the sine of the angle of inclination of the surface. This final product of the formula gives the actual velocity in feet per second.

It is necessary to bear in mind that new pipes will become old, and therefore that it will be safe to use the co-efficient for old pipes in all calculations, as the values of the co-efficients vary according to the roughness of the pipe or channel. The experience and judgment of the engineer must be called on to determine wisely what co-efficient to adopt between the extremes of 85 and 114, according to the inner surface of the pipe.

In cylindrical pipes the velocity in feet per second, multiplied by the square of the diameter of the pipe in feet multiplied by the constant number 47.124, gives the discharge in cubic feet per minute.

It was found by experiment with the flow of water

through the pipes of the Vartry water service to Dublin that the actual delivery and flow considerably exceeded the theoretical flow calculated from formula.

Some hydraulic engineers calculate the loss of head through friction in pipes as follows: To find the due delivery in gallons per minute multiply the diameter of the pipe in inches by the constant number 3, and find the fifth power of the product; multiply this by the head of water in feet, and divide the product by the length of the pipe in yards; find the square root of the quotient, which gives the number of gallons discharged per minute.

To find the head of water in feet necessary to discharge a given number of gallons through a given length and diameter of pipe, square the number of gallons and multiply by the length of pipe in yards, and note the result; multiply the diameter of the pipe in inches by the constant number 3, and find the fifth power of the product; divide this into the result already noted, and the quotient will be the requisite head of water in feet.

To find the diameter of a pipe of any given length which will deliver a given number of gallons per minute, square the number of gallons per minute, multiply by the length in yards, divide the product by the head of water in feet, find the root of the fifth power, and divide that root by the constant number 3.

To find the length of any given diameter straight pipe which will deliver a given number of gallons per minute under a given head of water, multiply the diameter in inches by the constant number 3, find the fifth power, multiply by the head of water in feet, and divide the product by the square of the number of gallons per minute.

To find the head of water necessary to overcome friction due to change of direction of flow in bends, first find the radius of the circle drawn through the centre line of the bend in inches, then the radius or half of the diameter of the pipe in inches, and divide the former into the latter. The quotient will be the ratio of the radius of the bend to radius of bore. Now, the co-efficients for the curvature thus found in pipes of circular section are as follows:—

·1	·2	·3	·4	·5	·6	·7	·8	·9	1·0
·131	·138	·158	·206	·294	·44	·66	·98	1·4	2·0

Now find the angle of the bend with the forward line of direction, divide by the constant 180, and multiply the quotient by the co-efficient for curvature as found in the table; multiply the product by the square of the velocity in feet per second, and the product by the constant ·0155. The final product gives the head of water in feet required to overcome the extra friction caused by the bend.

Box gives some general idea of the head of water lost by right-angle quick bends. In a 2-inch diameter pipe, with the velocity necessary to discharge 45, 65, 80, 95, 110, 130, and 160 gallons per minute, the loss of head in inches for each bend will be respectively 0·5, 1·0, 1·5, 2·0, 3·0, 4·0, and 6·0 in.

Overflow pipes are essential for all tanks, but are frequently fixed too small, and are sometimes neglected altogether. When they are provided as stand-pipes, having brass ground-in wash-out valve-washers, they should be formed with trumpet-shaped tops, as greatly increased efficiency is thus secured. Three inches margin of safety should be given from the top of stand-pipe to top of tank. If this loss of useful depth of tank cannot be afforded, recourse must be had to Mr. Appold's contrivance. He

places a hollowed copper cover over the trumpet mouth, fixed on brackets, so that the lip of the inverted hollow cover is level with the lip of the trumpet mouth. The water does not immediately flow over, but rises a little above the lip, suddenly overflows, causes partial vacuum, and the maximum quantity which the stand-pipe can take is discharged. The stand-pipe overflow may be within one

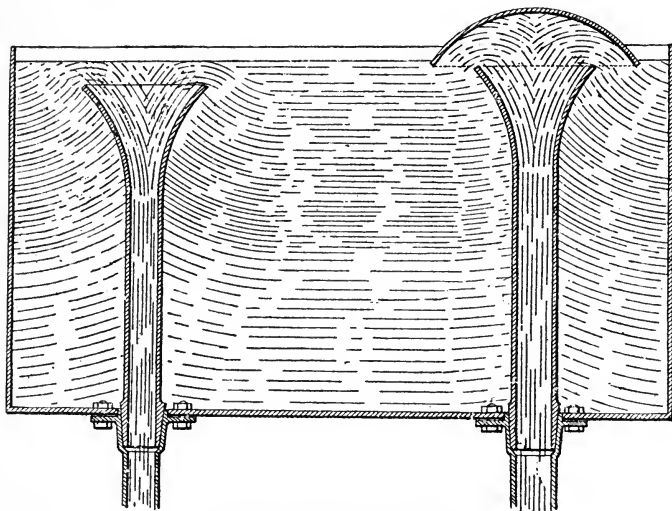

FIG. 13.—Overflow stand-pipes.

inch of the level top of cistern when this contrivance is adopted.

Stand overflow pipes three feet long, with ordinary trumpet mouths, will discharge the following quantities of water in gallons per minute :—

Diameter:	1 in.	1½ in.	2 in.	2½ in.	3 in.	3½ in.	4 in.	5 in.	6 in.
	18	40	80	140	200	300	400	600	900

It is necessary to bear in mind that overflows taken in short pipes from the sides of tanks will not give anything like the results shown by the stand-pipes, and increased



provision for safe overflow must be made. Side overflow pipes will only discharge the following quantities of water in gallons per minute:—

Diameter :	1 in.	1½ in.	2 in.	2½ in.	3 in.	3½ in.	4 in.	5 in.	6 in.
	3	8	12	30	50	70	110	170	280

This extraordinary difference in discharging power will surprise many plumbers.

#### AEROMETRY.

Aerometry brings us to consider another class of phenomena which plumbers require some acquaintance with in their trade.

Pumping water from wells, etc., syphonage in connection with flushing-tanks, steam heating, ventilation of drains, pipes, buildings, are all dependent on this branch of the laws of nature. Failure must follow the workmen and masters who know not these laws.

There are three layers of matter composing this earth: the solid ground, the liquid water, and the gaseous air. Fishes living in the liquid ocean are provided with contrivances suitable to the liquid medium in which they live; they possess a natural instinct which tells them where best they can exist, and warns them of dangers they must avoid. Fishes accustomed to shallow waters dare not go down to the depths of the sea, where deep-sea fishes alone may live; the increased pressure of sea water at those depths would crush them. Divers cannot work long under water owing to this constant pressure of the water on their bodies, and beyond a certain moderate number of feet depth they cannot exist at all. At the bottom of the great oceans, where the depth extends to thousands of feet, nothing can live: strong metal vessels are crushed in by the overpowering pressure.

We can see this ocean of water and can feel its power, so we learn by experience how best to control and utilise it.

There is another ocean, at the bottom of which we live and move. It is about a hundred times greater in height above us than the sea in depth below us. Fortunately it is also much lighter, or we would be unable to sustain the crushing pressure. Water is composed of a combination of oxygen and hydrogen gas. Pure air is composed of a mixture of oxygen (20·97), nitrogen (79·00), and carbonic acid gas (·03); aqueous vapour and sometimes ammonia, in varying proportions, are also found. Air containing 20·96 oxygen, 79·00 nitrogen, and ·04 carbonic acid is a fairly attainable pure air. The oxygen and nitrogen are always proportioned as nearly 21 parts oxygen to 79 parts nitrogen by volume in 100 parts. We cannot see the air, but occasionally we can both feel and see its effects when it moves, as in winds and storms, and we are constantly in subjection to the pressure of the atmosphere caused by the attraction of gravitation of the earth upon its particles of gaseous matter. The immense volume of the ocean of air above us presses down upon the earth in exact proportion to its mass.

We have already considered some of the properties of gaseous matter of which the atmosphere is formed. We know now that it is elastic and expansive; for if a small volume be admitted to an empty vessel it will expand and fill it; if compressed it will contract in volume, recovering and expanding when the pressure is removed.

In 1640 an Italian plumber in Florence, unacquainted with the science of aerometry, received an order to make, supply, and fix a pump over a well at the palace of the grand duke. He made a first-class pump, and fixed it with great care. The well was deeper than usual, and the water excellent, no doubt; but the water would not pump out of

the well, nor rise in the suction-pipe beyond a height of thirty-four feet from the surface, although the workmen pumped as rapidly and strongly as possible. The engineers of Florence were consulted, but were unable to explain the matter; the poor plumber, therefore, could hardly be blamed for his ignorance.

Galileo, then seventy-six years of age, was applied to; but he gave an unsatisfactory reply. However, the question set him to study the problem. He believed that the pressure of the atmosphere on the surface of the water in the well forced the water to rise as far as it did rise, and he saw at once that the answer, "Nature abhors a vacuum," was not a proper answer, for this gave no reason why Nature should abhor a vacuum up to a certain height, and then abhor it no longer. His experiments proved beyond doubt the weight of air, but before he could solve the problem he died, and the plumber's pump had to be taken away, and put in the window for some other customer!

Galileo's pupil, Torricelli, born in 1608, took up the question. He made a glass tube, which he closed at one end and then filled with mercury, which is thirteen and a half times heavier than water; he then reversed the tube, covering the open end with his finger, and plunged the end into a vessel of mercury. He watched the mercury descend in the tube and settle itself about thirty inches from the level of the mercury in the vessel, where it remained nearly invariable. Now, 30 inches of mercury multiplied by  $13\frac{1}{2}$ , the difference between the weight of mercury and water, gives 34 feet nearly; so Galileo was right in his theory that the thirty-four feet of water in the suction-pipe was supported by the pressure of the atmosphere, and the atmosphere being capable of supporting not more than thirty-four feet of water or thirty inches of mercury, it was useless waste of time to endeavour to make

more of it. To Galileo and Torricelli, therefore, plumbers are indebted for this knowledge. We need no longer try, like the Florentine plumber in 1640, to force our pumps to do impossibilities.

A curious experiment can be shown to prove the pressure of the air on the surface of liquids. A glass bell-jar, mounted on a metal plate, furnished with a pipe and stop-cock, is exhausted of air; the lower end of the pipe is placed in a vessel of water, the tap is opened, and instantly the pressure of the air on the water in the open vessel drives the water up like a fountain into the glass bell with great force.

The pressure of the atmosphere on the earth is about equal to what the pressure of a thirty-four feet deep stratum of water or thirty inches deep stratum of mercury would be if they surrounded the earth. On the summits of mountains, where there is a less height of atmosphere, it follows as a matter of course that the atmospheric pressure is less than on plains, where a greater height of atmosphere rests.

The barometer, for measuring this pressure of air, is simply an arrangement of Torricelli's tube, with the mercury carefully adjusted to indicate the variations which occur in the pressure of the atmosphere. On days when atmospheric pressure is greatest, any given pump will be capable of drawing up water a greater height than on days when the pressure is low.

We do not feel the pressure of the atmosphere on our bodies, although it amounts to about fifteen tons on each person, for the reason that it is exerted equally in all directions. A light glass flask can sustain this pressure of the air, because the air presses equally inside and outside; but if the internal pressure be removed by pumping all the

air out of the flask it must collapse under the external pressure, unless it be very strong indeed. A bladder skin tied across the mouth of a jar can sustain the atmospheric pressure so long as the atmosphere presses equally on both sides, but if by an air-pump the supporting air pressure is pumped out of and extracted from the jar, the outer pressure will press in the bladder more and more, until it gives way with a loud report.

The Hon. Robert Boyle, born at Lismore, Ireland, in 1626, investigated the phenomena of gases. Boyle's law is thus stated:—

The volume of gases varies inversely as the pressure, and the pressure varies inversely as the volume when the temperature remains constant. Suppose we have a jar or flask containing air at the same pressure as the atmospheric pressure; take away half the air, and the pressure on the inside of the flask will be half what it was; take away three-fourths of the air, leaving only one-fourth, and the pressure will be reduced to one-fourth.

The pressure of the air shut up in a flask is always proportional to its mass. If we double the quantity of air in the flask we shall have a pressure of two atmospheres; but the air occupies only half the space, for we see that double the volume of air is forced into the same space that held only one volume, and with double the volume confined in the same space we get double the pressure.

Gaseous pressure is equal to the density of the gas.

It is important to bear in mind that if the temperature of air in any closed vessel, pipe, or drain be raised the pressure will be increased, if the volume remains the same; if the vessel be opened, then the pressure will remain the same, but the volume of air will be increased, and the air as it expands will escape. If the temperature continues to increase, and the air be prevented escaping from the container,

pressure will increase in proportion on every part of the containing vessel, pipe, or drain, and the weakest point will first yield.

A gas-holder, perfectly balanced and filled to half its height with air or gas, will rise and fall according to the rise or fall of temperature communicated to the air or gas within. In an air-tight vertical cylinder fitted with a piston imagine the piston resting on a small quantity of air beneath it; raise the temperature of the air and it will seek to expand, according to Boyle's law, and, thus acting directly by increasing pressure on the piston, will push it upwards, unless an increased force be applied to the piston to resist the increased pressure. When hot water or heated air enters drains and pipes of houses the same action takes place upon any water-traps connected to closed, unventilated house-pipes and drains, only the traps offer much less resistance to pressure than an air-tight piston of the lightest construction.

This practical lesson of science has not until quite recently been thought worthy of consideration, thus thousands of valuable human lives have been sacrificed to the violation in practice of that law through ignorance; but now, knowing this law, the violation of it in practice becomes culpable negligence.

The action of the syphon is frequently made use of by plumbers for emptying tanks for water-supply, for flushing out drains and apparatus, and it is necessary to prevent it from attacking the water seals of traps and emptying them.

Syphonic action takes place in any bent tube having two legs or branches unequal in length. The shorter and upper tube, when filled and immersed in water, will produce no effect until the longer and lower tube also, and the bend, is filled with water; then, immediately, the liquid will rise above its level and flow over the edge of the tank, and will

continue flowing till air gets into the bend by some means. This action is due to gravitation acting through and with atmospheric pressure, which is also due to gravitation.

The atmosphere presses upon the water surface in the upper tank, and at the lower end of tube, whether free in air or immersed in water, the atmosphere presses equally, but in the opposite direction, causing equilibrium and rest; but as soon as the bend and long arm of syphon are filled with water, expelling the air, the greater weight of water in longer arm tends to cause a vacuum in the bend, and the pressure of atmosphere on water in upper tank at once sends the water up short arm and over the bend. The vacuum is prevented from forming in the bend by the water rising in the short arm continually, to replace the water dragged down in the long arm by its greater weight or gravity. In practical application of the syphon to flushing-tanks many difficulties arise in securing an automatic action in starting the syphon, which have been more or less successfully grappled with.

If the syphon bend be more than thirty-four feet over the water the weight of the atmosphere is no longer able to overcome by its pressure the weight of the water, and so a vacuum forms between the columns, which separate, each falling towards its own side.

#### HEAT.

The study of heat is of great interest and importance to engineers and plumbers. Heat is not matter, but a form of energy requiring matter to act by and through. The addition of heat adds no weight to an iron ball.

There are strong scientific reasons for believing that heat is a kind of vibratory motion, somewhat similar to light and sound, so that when minute particles or atoms of any substance are caused to move round and round each other,

or backwards and forwards with increased velocity, heat increases in proportion to the velocity of the movement and impact of the atoms.

Heat is measured in this country by a standard unit, viz. the amount of heat required to raise the temperature of a pound of water at 32° one degree Fahrenheit. The standard English unit for the measurement of work is the work done in raising one pound weight vertically one foot, called the foot-pound.

Professor Joule has proved that one pound falling 772 feet, or 772 pounds falling one foot, produces one unit of heat. Seven hundred and seventy-two foot-pounds is known as Joule's mechanical equivalent of heat. One unit of heat requires for its production and produces by its disappearance 772 foot-pounds, or 772 units of work; therefore one unit of heat should by theory do 772 units of work.

One pound of coal is estimated to contain, according to its quality, from sixteen to thirteen thousand units of heat, or more than from twelve to ten million units of work, or foot-pounds. If it were possible to apply it direct and without loss from friction, etc., one pound of coal should raise ten to twelve million pounds one foot high, but in practice so much loss occurs that only one-tenth of that work is obtained in steam-engines of the highest class.

Herschel estimates that if it were possible to prevent all waste of power, two pounds of coal should suffice to place a man on the summit of Mont Blanc, which requires two hard days' labour to ascend by man's unaided power of climbing.

As it is not possible to secure and direct all the energy of heat to one sole object, this estimate is of course imaginary; but it may serve the purpose of teaching that every effort is of value which improves machinery and mechanical appliances, as tending eventually to secure the



best possible effect. The man who succeeds in making one pound of coal do the work that required one pound and a quarter before is a benefactor to the human race. The extraordinary results obtained from fuel by the application of science in the construction of modern steam-engines amounts to a national revolution in importance within the last twenty years.

The effects and degrees of the expansion and contraction of metals caused by variation of temperature is well illustrated by Tyndall in his work on Heat.

The choir of Bristol Cathedral was covered with sheet lead, the length of the covering 60 feet, the depth 19 ft. 4 in. It had been laid in 1851, and two years later it had moved downwards eighteen inches; the force with which it descended drew out the fastenings. The roof was not steep, and the lead would have rested on it for ever without sliding down by gravity alone. During the day the heat caused it to expand, and, as it lay on the incline, it expanded downwards more easily than upwards. When the lead contracted at night its upper edge was drawn more easily down than its lower edge upwards. Its motion was therefore exactly that of a common earth-worm, pushing its lower edge forward during the day, and drawing its upper edge after it during the night; and thus, by slow degrees, it crawled through a space of eighteen inches in two years.

We may learn from this illustration the importance of noting the changes of volume in solids used in building and plumbing.

The expansion and contraction of liquids by heat is greater than of solids, and of gases greatest of all. Zinc appears to yield the greatest expansions under heat of any metal, the ratio being approximately—zinc, 32; lead, 29; tin and aluminium, 22; silver and bronze, 19; copper, 17; gold, 15; iron, 12; steel, 11; stone, 9; glass, 8.

Heat at temperatures above  $39^{\circ}$  causes water to expand, and in expanding the water becomes lighter bulk for bulk.

Take for instance an open pint measure, and fill it with water at  $60^{\circ}$  F.; apply heat and raise the temperature to  $200^{\circ}$ ; the water expands, and a small portion overflows owing to the expansion; the remaining portion must, therefore, become so much lighter, although at  $200^{\circ}$  temperature it still quite fills the measure, until the heat is withdrawn. When the temperature returns to  $60^{\circ}$  the bulk of the water will be found to have shrunk a little, so that, in order to fill the measure again, the same quantity of water which overflowed must be returned.

Take two tubes 1 inch in diameter, 10 feet high; place in vertical position side by side, fill both with water, apply  $140^{\circ}$  of heat to one only, the same result follows. The water expands and some portion overflows; the water in the heated tube becomes thus lighter than the water in the cool tube. Join the tubes at top and bottom by cross tubes, and instantly the heavier water in the cool tube will by gravitation press down on and push up the lighter water in the hot tube, causing the phenomena of circulation of water so long as the water in one tube is hotter than in the other—precisely as the heavy scale of a balance will by gravitation push up the lighter scale against gravitation.

#### SPECIFIC HEAT.

All bodies have not the same capacity for heat, and as the relative densities of bodies is termed specific gravity, so the difference of relative capacities of bodies for heat is termed specific heat, and is the number of units of heat required to raise the temperature of any given body  $1^{\circ}$  F. This specific heat varies not only with the differences of the bodies themselves, but also with the different tempera-

tures of the same bodies, except in the case of gases. For instance, Dulong found that the variation in the specific heat of zinc between 32° and 212° is .0927; between 32° and 572°, .1015. This variation, so far as plumbers are concerned, is not of very great importance, but they should be acquainted with the facts.

The specific heat of lead is .0314; water at 32° being 1.000, or, as it is called, unity. Therefore to heat 212 pounds-weight of lead 100° F.—

$$212 \text{ lbs.} \times 100^\circ \times .03140 = 665 \text{ units of heat required;}$$

and to heat 212 lbs. of water—

$$212 \text{ lbs.} \times 100^\circ \times 1.000 = 21,200 \text{ units of heat required.}$$

This makes decidedly a practical difference.

Regnault gives the specific heat of some bodies, water at 32° being unity = 1.000.

Hydrogen . . . . .	3.294	Petroleum . . . . .	.434
Cast iron . . . . .	.1298	Sulphur . . . . .	.203
Copper . . . . .	.095	Glass . . . . .	.198
Mercury . . . . .	.0333	Zinc . . . . .	.0955
Sulphuric ether . . . . .	.477	Tin . . . . .	.0569
Air . . . . .	.207	Lead . . . . .	.0314
Wrought iron . . . . .	.114	Bismuth . . . . .	.308
Silver . . . . .	.057	Coke . . . . .	.2
Platina . . . . .	.0324	Coal . . . . .	.277

When the density of metal is increased by hammering its specific heat diminishes. We can see that a dense body like lead has less capacity for heat than cast iron, which is less dense. Copper has less capacity for heat than iron. The amount of heat capable of raising one pound of water one degree will raise nine pounds of iron, eleven pounds of copper, and thirty pounds of mercury to the same temperature.

We have already learned, and once for all, that heat cannot be destroyed nor created; it may be transmitted

from one substance to another, from one form of matter to another form of matter, or it may be transformed into other forms of energy, or into work from which it may be again recovered. If we draw heat from a furnace into an iron sphere, and instantly plunge the hot sphere into water, the exact amount of heat taken from the fire is transferred to the water, not destroyed or obliterated. The water then may transmit the heat to other substances, but we may conceive the possibility of collecting and restoring that heat so transmitted at any time.

Heat is transmitted or dispersed in three different ways—by radiation, by convection, by conduction.

#### THE TRANSMISSION OF HEAT BY RADIATION.

If an iron vessel containing water heated to  $200^{\circ}$  be placed in the centre of an iron chamber, the air within, say, at  $56^{\circ}$  temperature and the sides of the iron chamber  $56^{\circ}$ , rays of heat, or radiant heat, will be transmitted through the air in all directions at right angles from the heated surface of the vessel, and in straight lines, until they are intercepted by the sides of the chamber and reflected or absorbed. These radiant heat-rays, whether proceeding from a glowing or a dark hot body, possess the remarkable property of passing through air without perceptibly communicating heat thereto directly. The radiant heat from the sun passes through our atmosphere without raising its temperature, but it warms the earth, which communicates the heat to the air by convection. The radiant heat from an open fire-grate passes through the air in the room without effect, but it warms the floor, walls, and furniture, which in turn heat the air by convection.

Radiant heat passes away or radiates from steam pipes, hot-water pipes, stoves, walls, windows, the bodies of animals and vegetables, and, in fact, from every substance,

so long as the temperature of that substance is higher than that of any other objects within the sphere of influence. Thus, if in winter, after a brisk walk, we enter a room at  $45^{\circ}$  temperature in which blazing fires had been recently lighted, we soon become conscious of a feeling of coldness, even in the presence of the fire, caused by our warm bodies radiating away the heat to the cold walls and surrounding objects; and we shall continue to experience this sensation of cold until sufficient time has elapsed to allow the radiant heat of the fire to raise the temperature of the walls, floor, etc., to the same temperature as that of our bodies.

If we suppose such a cold room, at  $45^{\circ}$  temperature, fitted with hot-air apparatus, instead of an open radiant fire, and that, immediately before our entrance, hot air was admitted sufficient to raise the temperature of the air to  $60^{\circ}$ , while the walls, etc., were  $45^{\circ}$ , we should experience the same sensation of cold; for our bodies would immediately radiate their heat to the colder walls, etc., through the warm air, and would continue to do so until by some means the walls, etc., became warmed. Our bodies would also lose heat by convection to the air passing over us in draughts or currents caused by unequally heated columns of air cooled by the cold walls.

If we suppose such a room thoroughly warmed before our entrance, so that walls, floors, and furniture were at  $70^{\circ}$  temperature, and that suddenly all the warm air was withdrawn and cold air admitted at a temperature of  $45^{\circ}$ , we should be conscious only of a delightful freshness of the air; our bodies would not lose any heat by radiation, but we should keenly observe cold draughts, the air next the walls becoming warmed by convection, the cold air in the centre of the room falling and causing draughts or currents, and removing heat by convection from any parts of our body exposed to the passing colder air.

The amount of radiant heat emitted and received varies greatly with the nature of the surface affected; the power of radiating and the power of absorbing heat are equal in the same surface.

The power of giving and receiving radiant heat to and from surfaces at ordinary temperatures is simply proportional to the difference of temperature between the giving and receiving surface at high temperatures, with which we have not much concern. Dulong has shown great variation from this rule.

For low temperatures, Péclet's experiments give the following results, showing units of heat given and received per square foot per hour for each degree Fahrenheit of difference of temperature:—

Copper, silver-plated and polished . . . . .	·0265	Chalk . . . . .	·678
Copper . . . . .	·0327	Wood sawdust, fine . . . . .	·721
Tin . . . . .	·0439	Stone, plaster, brick . . . . .	·735
Zinc and brass, polished . . . . .	·049	Fine sand . . . . .	·74
Tinned iron . . . . .	·0858	Calico . . . . .	·746
Sheet iron, polished . . . . .	·092	Woollens, any colour . . . . .	·752
Sheet lead . . . . .	·1328	Silks . . . . .	·758
Sheet iron . . . . .	·566	Oil paint . . . . .	·758
Cast iron . . . . .	·648	Paper, any colour . . . . .	·77
Rusty iron . . . . .	·687	Lampblack . . . . .	·82
Glass . . . . .	·595	Water . . . . .	1·085
		Oil . . . . .	1·48

We thus find that sheet iron, and particularly rusty sheet iron, will absorb and give out more heat than sheet lead, in a proportion which we can calculate from Péclet's table of results.

Metals possess the least radiant power. The effect of colour is slight; white lead radiates as well as lampblack. Polish influences and lessens radiation, roughness of surface increases radiating power.

We have pointed out that radiant heat is transmitted in straight lines and at right angles from the heating surface,

through the air or in vacuo, to any distance, however remote, until intercepted and absorbed by some intervening matter. A heated sphere of iron, suspended in the centre of a room, so long as its temperature is higher than the walls of the room, will transmit rays of radiant heat in straight lines and in all directions through the air, which they do not affect until they strike and are absorbed or reflected by the walls. If the temperatures are reversed, the iron sphere having a temperature lower than that of the walls of the room, then the walls will transmit effective rays of radiant heat in straight lines and in all directions at right angles with the surfaces until the temperature is equalised. The effect in each case will be very different, all the rays proceeding from the iron sphere taking effect on the cooler walls, while a very small proportion of the rays from the walls reach the sphere directly, the remainder practically negating each other, neither losing nor gaining, and not directly affecting the sphere; indeed, where temperatures are like, radiant heat action is considered to cease.

It will be seen that if the sphere was placed inside a spherical chamber the converging rays should meet in the sphere, and the effect on its temperature be at its maximum so long as the sphere remained cooler.

The same laws appear to govern both radiant heat and light. The lens of a telescope may be used to collect heat rays as well as light rays, and to concentrate them on one point, as in a burning-glass. All bodies, whatever be their temperature, emit or radiate heat.

Opposite surfaces of bodies radiate towards each other; the heat which each receives is partly reflected or diffused, partly absorbed by conduction from particle to particle, raising the temperature of the body, and partly transmitted through the substance of the body to other bodies beyond.

Bodies of unequal temperature in a confined space interchange their heat till equilibrium of temperature is established.

The heat radiating and absorbing powers of bodies are equal, and the heat-reflecting power of a body not transparent to radiant heat is the complement of the radiant and absorbing power.

If the intensity of the ray of heat be represented by 100 we are given the following numbers:—

	Reflecting power.	Radiating power.		Reflecting power.	Radiating power.
Polished silver	97	3	Steel . . .	83	17
Red copper . .	93	7	Glass . . .	10	90
Polished brass .	93	7	Lampblack . .	0	100
Platinum . . .	83	17			

Good reflectors of heat are therefore bad radiators.

The theory of radiant heat has been stated thus: If an enclosure be kept at a uniform temperature, any substance within it will attain that temperature. All bodies are constantly giving out radiant heat, independently of the temperature of the bodies which surround them.

Therefore, when a body is kept at a uniform temperature, it receives back as much heat as it gives out.

Bodies when cold receive the same rays which they give out when hot.

The intensity of radiant heat varies inversely as the square of the distance, as with radiant light, and also as with the attraction of gravitation.

When bodies are heated the first radiant heat is given off in obscure or dark rays, conveying the sensation of heat, only without light; as the temperature rises the rays begin to affect the eye in increasing numbers, making the body assume in turn a red heat, yellow heat, and white heat.



## THE TRANSMISSION OF HEAT BY CONVECTION.

The conductivity of liquids and gases for heat is very slight—in the case of gases it has not been fully proved to exist—nevertheless heat is rapidly transfused throughout their volume, owing to their qualities of expansion and mobility, by direct transport of the heated particles. These particles, expanding and becoming lighter or less dense by contact with heat, are forcibly displaced by the greater weight of any colder particles above them, and are driven upwards, carrying heat with them, and transmitting heat by convection. Heat applied at the lowest point of any vessel or apparatus has, therefore, a better effect than when applied at the sides or top, for as the colder particles fall and displace the heated ones, they in turn receive the heat by the closest and most direct contact at the bottom, become lighter, and are displaced in rotation by other colder and denser particles setting up a circulating current. Heat applied at the side of a vessel, as in the side flues of boilers, causes the currents of side-heated particles to start only from that point of the sides where the heat is applied, consequently the lower down the side flues are formed the greater will be the heating effect. Heat applied at the top of a boiler is almost useless, except in checking upward outward radiation of heat from the boiler.

Heat applied at the bottom is, therefore, the most rapidly diffused, and is the really effective heat in any boiler. The particles of heated water, being driven away from contact with the heated bottom surface, rise through the longest section of colder water in the boiler, transferring heat by convection as they pass among the descending particles.

Similar convected or transported heat action takes place in air with much greater rapidity, and is the principal

effective cause of the warming of the air, whether it be the outside open air, or confined in buildings.

#### THE TRANSMISSION OF HEAT BY CONDUCTION

can be observed easily by placing one end of a bar of metal in a fire, and holding the other end in the hand. The heat will pass from the fire and be transmitted or conducted from particle to particle of iron, until in time the hand must be removed, unless the length of the bar be such as to exceed the conducting power, which varies in different metals, and in some is soon overcome by the radiating power emitting the heat as rapidly from the surface of the metal as it is transmitted to it by conduction.

The following list gives the degree of conductivity of various substances:—

Silver	.	.	.	1000	Steel	.	.	.	116
Copper	.	.	.	776	Lead	.	.	.	85
Gold	.	.	.	532	Platinum	.	.	.	84
Brass	.	.	.	236	Palladium	.	.	.	63
Zinc	.	.	.	190	German silver	.	.	.	60
Tin	.	.	.	145	Bismuth	.	.	.	18
Iron	.	.	.	119					

Of solid bodies, metals—excepting bismuth—are the best conductors of heat. As an easy experiment, place a silver spoon and a German silver spoon in one vessel of hot water, each having a grain of phosphorus on the end. That on the silver will quickly ignite, while that on the German alloy will remain unaffected, showing the difference clearly between the conducting powers of these two metals.

This knowledge is useful to plumbers, enabling them to select suitable metals to effect in the best way certain definite purposes in heating apparatus, and to use suitable materials to prevent waste and diffusion of heat, which they may have contracted to convey and deliver at distances from the sources of heat at their command.

## LATENT HEAT.

The processes of melting solids and vapourising liquids take place at certain defined temperatures, which are the same for the inverse processes of solidification and liquefaction. Thus, ice melts at  $32^{\circ}$  to water, and water vapourises at  $212^{\circ}$  to steam; and by inverse process steam liquefies at  $212^{\circ}$  to water, and water solidifies at  $32^{\circ}$  to ice—the critical point of the change of state being close to the given temperatures.

When heat is continuously applied to ice the ice melts, and continues melting into water at  $32^{\circ}$ ; but the heat does not raise the apparent temperature, nor affect the thermometer, which remains at  $32^{\circ}$  constant. The heat is absorbed by the ice and water and becomes latent or concealed, and is termed the latent heat of liquefaction. This latent heat is disengaged when the water is changed back to ice.

One pound of water at  $212^{\circ}$  in an open vessel requires 966 units of heat to convert it into steam at  $212^{\circ}$ , and this is termed the latent heat of vapourisation. If the steam be condensed again to water the same quantity of heat will be disengaged. This fact is taken advantage of in warming buildings, and in heating large quantities of water in tanks by steam.

Ice requires latent heat to convert it into water; water requires latent heat to convert it into steam. One pound of ice at  $32^{\circ}$  takes as much heat to change it into water at the same temperature as would raise the temperature of 142 pounds of water one degree; and as one pound of water at  $212^{\circ}$  takes as much heat to change it into steam at the same temperature as would raise 966 pounds of water one degree, the latent heat of water is said to be 142, and of steam 966.

The latent heat of vapourisation is measured from the

number of units of heat required to change liquids from their boiling point into vapour under an atmospheric pressure of thirty inches of mercury.

The latent heat of water = 966; alcohol, 457; ether, 313; naphtha, 184.

Heat is disengaged when substances enter into chemical combination, as instanced by carbon and oxygen in combustion, water and quicklime, water and sulphuric acid.

Heat is also disengaged by mechanical action—friction, percussion, and compression.

#### MEASUREMENT OF HEAT.

Heat cannot be measured by our sensations. It does not affect our bodies equally; it produces sensations differing not only according to the degrees of the heat itself, but also to the varying condition of our bodies and of our surroundings. If we enter a room at  $60^{\circ}$  directly from frosty air outside at  $30^{\circ}$  we feel the inner air too warm; yet the very same air will feel cold if we enter it directly from a Turkish bath heated to  $150^{\circ}$ .

If we plunge one hand in water at  $120^{\circ}$  and the other in water at  $40^{\circ}$ , and, suddenly withdrawing them, plunge both together into water at  $80^{\circ}$ , we shall experience the opposite sensations of heat and cold from the same water at the same moment.

Heat, therefore, cannot be measured by our sensations; hence the value and necessity of thermometers, or heat-measurers.

Heat causes bodies affected by it to expand, or to become lighter bulk for bulk, as they increase in temperature. There is one exception to this rule. Heat applied to water at  $32^{\circ}$  F. causes the water to contract until it reaches  $39^{\circ}$  F., at which temperature it commences to ex-

pand until it reaches the boiling point, 212°, after which, at ordinary atmospheric pressure, it expands into steam.

The temperature of water and air is measured in various ways. The mercury thermometer is the instrument usually employed. In France, and generally for scientific research, the thermometer adopted is marked on the scale called centigrade, in which freezing point is zero, or 0°, and boiling point 100°, with 100 equal degrees marked between. In Germany the thermometer is marked on the scale called after Reaumur, in which freezing point is zero, or 0°, and boiling point 80°, with 80 equal degrees marked between. In England the thermometer is marked on the scale called after Fahrenheit, in which freezing point is 32° and boiling point 212°, with 180 equal degrees marked between, the zero, or 0° point, being therefore 32° below freezing point, and chosen by Fahrenheit as zero because it was at that time supposed to be the point of greatest cold.

Plumbers often require to convert centigrade into the Fahrenheit scale, and *vice versa*. This is easily done. Multiply the centigrade degrees by 9, and divide the product by 5, and add 32, the result being the corresponding degrees on Fahrenheit scale—

$$\frac{9 \text{ C.}^\circ}{5} + 32^\circ = \text{F.}^\circ$$

Thus, to convert the boiling point of 100° centigrade to Fahrenheit—

$100^\circ \times 9 = 900 \div 5 = 180^\circ + 32^\circ = 212^\circ \text{ F.}$ , boiling point;  
which, being translated, is—multiply 100 by 9, equals 900;  
divide this by 5, equals 180; add to this 32, equals 212.

$$\begin{array}{r} 100^\circ \text{ centigrade boiling point.} \\ 9 \\ 5 \overline{)900} \\ \underline{180} \\ 32 \\ \underline{212^\circ} \text{ Fahrenheit boiling point.} \end{array}$$

The same course is adopted to convert any other given temperature.

To reverse the proceeding, and convert Fahrenheit scale into centigrade, subtract 32° from the given temperature, multiply the remainder by 5, and divide the product by 9.

Thus, to convert 104° Fahrenheit into centigrade—

$$104^{\circ} - 32^{\circ} = 72^{\circ} \times 5 = 360^{\circ} \div 9 = 40^{\circ} \text{ C.}$$

Subtract 32 from 104, equals 72; multiply by 5, equals 360; divide by 9, equals 40.

$$\begin{array}{r} 104^{\circ} \text{ Fahrenheit.} \\ \underline{32} \\ 72 \\ \underline{5} \\ 9 \overline{)360} \\ 40^{\circ} \text{ centigrade.} \end{array}$$

To convert centigrade to Reaumur:  $\frac{4 \text{ C.}^{\circ}}{5} = \text{R.}^{\circ}$

To convert Reaumur to centigrade:  $\frac{5 \text{ R.}^{\circ}}{4} = \text{C.}^{\circ}$

To convert Fahrenheit to Reaumur:  $(\text{F.}^{\circ} - 32^{\circ}) \frac{4}{9} = \text{R.}^{\circ}$

To convert Reaumur to Fahrenheit:  $\frac{9 \text{ R.}^{\circ}}{4} + 32^{\circ} = \text{F.}^{\circ}$

The boiling point of liquids at atmospheric pressure is given by various authorities:—

	Degrees.		Degrees.
Water . . . . .	212	Nitric acid (Dalton) . . . . .	220
Mercury (Regnault) . . . . .	662	Muriatic acid (Dalton) . . . . .	222
Linseed oil (Ure) . . . . .	600	Alcohol (Ure) . . . . .	173
Sulphur (Ure) . . . . .	570	Ether, sulphuric (G. Lussac) . . . . .	100
Naphtha (Ure) . . . . .	306	Water saturated with chloride	
Oil turpentine (Ure) . . . . .	316	of calcium . . . . .	355
Sulphuric acid (Dalton) . . . . .	240-620		

The boiling point of water at different pressures varies as Regnault has proved, in the following proportions:—

At half atmospheric pressure, or with mercury at 15 inches, water boils at 180° F.

At atmospheric pressure, or with mercury at 30 inches, water boils at 212°.

At a pressure of 2 atmospheres, or 60 inches of mercury, or 14·7 lbs. per square inch, water boils at 249°.

At a pressure of 3 atmospheres, or 90 inches of mercury, or 29 lbs. per square inch, water boils at 273°.

At the following pressures water boils:—44 lbs., 291°; 59 lbs., 306°; 73 lbs., 319°; 88 lbs., 330°; 103 lbs., 339°; 117 lbs., 348°; 132 lbs., 357°.

In high-pressure small-bore heating apparatus this proportion may be observed.

The melting points of solids given by M. Pouillet seem to be the most reliable:—

	Degrees.		Degrees.
Wrought iron . . .	2910-2730	Bismuth . . .	518
Steel . . .	2550-2370	Tin . . .	455
Cast iron . . .	2190-1920	Sulphur . . .	239
Gold . . .	2280-2156	Wax . . .	154
Copper . . .	2050	Spermaceti . . .	120
Silver . . .	1830	Phosphorus . . .	109
Brass . . .	1650	Tallow . . .	92
Antimony . . .	810	Oil turpentine . . .	14
Zinc . . .	793	Mercury . . .	-40
Lead . . .	630		

MELTING POINTS OF ALLOYS.

Lead.	Tin.	Degrees.	Bismuth.	Lead.	Tin.	Degrees.
3	1	504	4	1	1	201
1	1	466	8	5	3	212
1	2	385*	5	2	3	212
1	5	381	5	1	4	246
1	4	372	1	0	1	286
1	3	367	1	0	2	334

The freezing points of liquids, given by Dr. Ure:—Salt

\* Other authorities give: Lead 1, tin 2=340°; lead 2, tin 1=440°; lead 3, tin 1=480°.

## 100 DOMESTIC SANITARY DRAINAGE AND PLUMBING.

one part, and water three parts, by weight, freezes at  $+4^{\circ}$  F. above zero; sulphuric acid, at  $-45^{\circ}$  below zero; sulphuric ether, at  $-46^{\circ}$  below zero.

### FLUXES USED FOR SOLDERING OR WELDING.

Iron or steel	.	.	.	Borax or sal ammoniac.
Tinned iron	.	.	.	Resin or chloride of zinc.
Copper and brass	.	.	.	Sal ammoniac or chloride of zinc.
Zinc	.	.	.	Muriate or chloride of zinc.
Lead	.	.	.	Tallow or resin.



## CHAPTER IV.

### SEWAGE DISPOSAL.

THE disposal of sewage should be the first consideration when arranging for suitable sanitary fittings in any town or country house; constant danger and trouble may be expected if the arrangements for the disposal of sewage be not complete. Difficulties frequently arise in the case of country houses; we generally find that where a stream or river is at hand it is unhesitatingly adopted as the outfall for house drainage, contrary to the provisions of the Rivers Pollution Act, now almost a dead letter. When some such convenient outfall is not available an open ditch or a closed cesspool is used.

For the drainage of town houses the local sanitary authorities are bound to provide public main sewers; the health of the inhabitants varying much, according to the character of these sewers. Plumbers are compelled to take these sewers as they find them, but in the arrangement of the house drains and connections plumbers are bound to observe all necessary care and caution, with skill, to protect the householders from injurious sewer-air influences.

In some towns the public sewers are so perfect that no improvement can be desired, while in others they are dangerous sewers of deposit, or prolonged cesspools, without fall or ventilation.

It is essential that plumbers should appreciate and understand the dangerous nature of the air of cesspools and

defective sewers. In nearly all instances this air contains a variable amount of sulphuretted hydrogen, ammonium sulphide, nitrogen, carbonic acid, carburetted hydrogen, and foetid organic matter. As these gases pass easily through walls it is dangerous to allow cesspools or public sewers to be found close to dwellings; yet, notwithstanding this danger, we frequently find them in this unsafe juxtaposition.

The dangerous character of cesspool or sewer air is always increased with the quantity of gases evolved from the sewage, together with absence of ventilation. It is almost a settled question that the germs of typhoid fever, cholera, dysentery, diarrhœa, and other diseases may be present in and spread by cesspool and sewer air. Small-pox, scarlatina, measles, etc., if not arising directly from sewer air, may be communicated from house to house by unsuspected sewer and drain connections of one or more houses with an infected house on the same line of public sewer.

Professor Frankland showed, by experiment in 1877, that solid or liquid germs are not given off to the air from ordinary sewage, even when agitated, until decomposition has set in; that after decomposition has commenced the bursting of bubbles of carbonic acid gas disengages these germs, and, therefore, that ordinary sewage becomes dangerous only after decomposition; and it follows that if ordinary sewage be rapidly conveyed away and disposed of at once the danger arising is reduced to the lowest point. It is possible, however, that infection may be communicated from scarlatina and other infectious drainage before decomposition sets in.

Cases of asphyxia occasionally occur from the opening up of old cesspools or defective sewers. The effluvia arising from drains which have been choked produce dangerous

and distressing effects. Drain air entering houses by any means whatever invariably causes an impaired state of health, especially in children. Healthy appetite is lost; they become pale and languid, and may suffer from diarrhoea and sore throat, headache, malaise, feverishness, pneumonia, and anæmia. It aggravates decidedly cases of erysipelas, hospital gangrene, and puerperal fever.

Dr. Parkes states:—"The doctrine that a specific cause is necessary for the production of typhoid fever; that this cause is present in the intestinal discharges, and that sewer and faecal effluvia, and faecal impregnation of water, are thereby the channels by which this specific cause reaches the body of a susceptible person, will be found to explain almost all the events which have been recorded in connection with the origin of typhoid fever."

Without further argument all may admit that the air of ordinary town sewers or country cesspools is dangerous air to admit into dwellings, especially when we remember that the dangerous infected drainage from fever hospitals, and the excreta of patients suffering from infectious diseases in many private houses, is discharged direct into such sewers, and that the germs emanating therefrom may carry death with them through the branch connecting drains into the houses.

We should distinguish accurately, in speaking and writing, between sewers and drains, although authorities differ as to the proper use of the terms.

A drain has been legally defined in the Public Health Act, 1875, as follows:—"A drain" is any drain for the drainage of *one* building or premises only, for the purpose of communicating therefrom with a cesspool, or with a sewer, into which the drainage of two or more buildings, occupied by different persons, is conveyed.

"Sewer" includes sewers and drains of every description, except private drains as defined above, and drains under

the control of road authorities, not being local sanitary authorities under the Act, such as county road drains and watercourses.

The disposal of sewage frequently furnishes problems of great engineering difficulty, especially at inland places. It is not our purpose to go into the details of the various systems, but we shall do well to consider some of them superficially.

The open ditch outfall for sewage disposal needs no comment, further than to remark that this primitive method exists for thousands of houses throughout the country, the liquids evaporating and oozing away as they may, and the solids being occasionally removed by farmers for manure. These ditches become offensive, but when far enough removed from dwellings, and especially from wells or water-supply sources, the constant free access of air to and about them appears to bring into effect certain purifying influences, and to prevent actual mischief from the effluvia.

The covered cesspool, built of loose stones, is frequently found in existence, all the liquids draining away through the soil, and only the solids remaining behind. These solids are supposed to be removed from time to time; and as the contents rapidly putrefy, giving off noxious gases, especially when disturbed, such cesspools should be at a distance from dwellings, and avoided as much as possible during the time of emptying them. Wells of water near these cesspools, or even at great distances, if the wells be deep and the underlying strata unfavourable, may become polluted by underground soakings from such cesspools. Wherever such imperfect means of sewage disposal is found and retained extreme care must be taken to cut off all connection between the cesspool and the dwelling, and means of ventilation should be well considered.

The covered cesspool, built of brick or stone, cemented water-tight, and provided with an overflow pipe, is very commonly adopted for country houses, where no better outfall can be found. The security of wells in the neighbourhood, of course, depends upon the staunchness of this tank, and on the safe disposal of the overflow water. All such tanks also require open ventilation, and must be thoroughly disconnected from the house or dwelling. They also need to be periodically pumped out and cleansed thoroughly. To facilitate this process it is better not to cover in the cesspool with solid brick arch, but to lay two- or three-inch flags across on iron girders, with an air-tight access manhole cover set beside the open ventilator.

The air in these tanks must be excluded with special care from dwellings, by an interceptor at the tank, with ventilation at the tank and at the drain side of interceptor.

The overflow water must be carried away and disposed of at some point where wells shall not be polluted thereby. It may be distributed through small pipes under grass lands at a lower level than the overflow, where the roots of plants, crops, etc., will absorb and utilise the waste sewage with great advantage.

Care must be taken in all cases that wells are not polluted. This great danger attends all such disposal of sewage, as subsoil waters may travel a considerable distance underground from a polluted source to a deep well if the underlying strata be unfavourable.

The discharge of sewage into streams and rivers is prohibited by the Rivers Pollution Act, 1876, but such great difficulties have arisen in the enforcement of this Act, that in many parts of the country the law is evaded so successfully as to render the Act practically valueless for its purpose. The same law prohibits also the discharge of sewage into tidal waters under certain conditions.

When sewage is allowed to discharge into a river it is considerably purified by the subsidence of solids, absorption by water plants, and by oxidation in running over stones and weirs, etc. Dr. Letheby states that sewage mixed with twenty times its bulk of river water will be perfectly oxidised when it flows for nine miles, but it would hardly be safe to use such water for potable purposes.

The treatment of sewage by precipitation with chemicals has not proved altogether successful; the sewage has not been rendered so pure as to be incapable of polluting running water, and the process is costly, the agricultural value of the deposits hardly repaying the cost of removal to the farm. The value of the ammonia, nitrogenous organic matter, and phosphates dissolved and suspended in average town sewage is about twopence per ton.

The removal of suspended matters by subsidence is simple, but as this matter in suspension contains only one-seventh of the valuable portion of the sewage, it does not pay for extraction, and the process still leaves behind six-sevenths of the putrescible organic matter in solution; and therefore treatment of sewage by subsidence is only a slight mitigation of the nuisance, and leaves the polluting nature of the liquid practically unchanged.

The processes employed in precipitation are:—

1. The lime process.
2. The lime and chloride of lime process.
3. The lime and chloride of iron process.
4. The A. B. C. process (alum, blood, and clay).
5. The lime and sulphate of alumina process (Anderson's Patent).
6. The lime, chloride of magnesium, and tar process (Hille's Patent).

7. The lime and black ash waste process (Hanson's Patent).

8. The ferrozone and polarite and sand process (International).

9. The sulphate of iron process (Conder's Ferrometer).

The lime process has been adopted at Blackburn, Leicester, Birmingham, Bradford, Chester, Wimbledon, Burton-on-Trent, Chiswick, Ealing, Birkdale, etc.

Tanks are provided in which the liquid sewage is mixed with lime water, agitated by machinery, and run off into subsidence tanks, where a deposit of putrescible sludge falls to the bottom. The liquid flows off rather turbid, certainly far from being pure, and the sludge is pressed into a mass of little manurial value.

The lime and chloride of lime process was tried at Hertford. From two or three grains of lime and a quarter to half a grain of chloride of lime per gallon of sewage was used, but not found sufficient. About eighty per cent. of the matters in suspension was removed by this process; then, by filtering through six inches of gravel and sand, about one-half of the polluting matter in solution was extracted. The action of the chloride has the effect of only retarding putrefaction of sewage; it does not prevent it altogether.

The lime and chloride of iron process has been tried in Northampton and a few other places, but has been a failure. The effluent sewage was discharged in apparently a pure state, but it really contained a quantity amounting to one-half of the original putrescible organic matter in solution. Chloride of iron delayed the putrefaction for a considerable time, but the effluent was found to become putrid a mile or two beyond the outfall. The chloride cost £6 per ton at Northampton.

The A. B. C. process has been adopted by many towns with meagre success, apparently depending on the quality of sewage and care of treatment, and therefore variable. Aylesbury, Bolton, Hastings, Leicester, Leamington, Leeds, London, and Southampton have tried the system, but it has been given up in all except Aylesbury.

The original specification of the patent describes the process for those who wish to study it fully. The proportions of the ingredients are given in parts as follows:—Alum, 600; blood, 1; clay, 1,900; magnesia, 5; manganate of potash, 10; burnt clay, 25; chloride of sodium, 10; animal charcoal, 15; vegetable charcoal, 15; magnesian limestone, 2.

The Rivers Pollution Commissioners found, after careful trials at Leicester and Leamington, an average of ninety per cent. of matters in suspension and twenty-nine per cent. of matters in solution were removed at Leicester, eighty-seven per cent. in suspension and twenty per cent. in solution respectively at Leamington; but at Leamington the proportion of chemicals used was twice as strong as given in the specification. In a laboratory experiment, where the errors likely to occur in the practical investigations at the above towns were eliminated, it was found, with crude London sewage, that 99·9 per cent. of organic suspended matters and 24·8 per cent. of organic dissolved matters were removed.

The results of the Commission laboratory experiment are instructive and interesting:—

	London Sewage—	
	Before the Process.	After the Process.
Total solids after evaporation . . . . .	67·3	80·5
Organic carbon . . . . .	3·614	2·257
Organic nitrogen . . . . .	1·886	1·878
Ammonia . . . . .	5·418	6·086
Total combined nitrogen . . . . .	6·34	6·89
Chlorine . . . . .	10·30	10·20
Mineral matter in suspension . . . . .	10·30	traces
Organic matter in suspension . . . . .	18·00	traces



It is remarkable that the amount of some of the impurities was increased in the process, doubtless by the added chemicals, clay, blood, etc.

The Commissioners, who took much interest in the investigation, hoping to find in this process a means of purifying sewage before discharge into streams and rivers, report as follows on the analysis:—

“1. Of the dissolved matters those left on evaporation were increased in weight by nearly one-half the amount of soluble ingredients added to the sewage; for the A. B. C. mixture, making up 100,000 parts with the sewage to which it was added, contained 27·8 parts of soluble matters left on evaporation, whilst the increase of soluble matters left on evaporation shown in the above table amounts to 13·2 parts.

“2. The organic carbon in the dissolved matters was diminished to the extent of 37·5 per cent.

“3. The organic nitrogen in the dissolved matters underwent no alteration; consequently the organic matters precipitated from solution by the A. B. C. mixture were non-nitrogenous, and therefore valueless as manure.

“4. The proportion of ammonia was augmented, because more was added in the A. B. C. process than was precipitated by the action of that mixture upon the sewage. 100,000 parts of the A. B. C. mixture gave on analysis 132·1 parts of ammonia; there was consequently added to each 100,000 parts of sewage in the A. B. C. mixture 1·32 part of ammonia, while the augmentation of ammonia shown in the above table is 0·668 part.

“5. No nitrates were formed in the operation.

“6. The total combined nitrogen was augmented by the ammonia added in the A. B. C. mixture; consequently, as regards soluble constituents, the effluent liquid possessed a greater manure value than the raw sewage, the increase in value being due to the chemicals employed.

“7. The proportion of chlorine remained unaltered.

“8. The matters in suspension, both mineral and organic, were almost completely removed, although the defecated sewage remained perceptibly turbid.”

The theoretical manurial value of the dried sludge was calculated at £1 12s. a ton, and the actual cost, exclusive of labour, fuel, wear and tear of plant, and interest, was £1 18s. 5d. Further investigations and tests at Aylesbury have not given more favourable results.

The lime and sulphate of alumina process has been tried at Coventry, Nuneaton, and Leyton; but intermittent filtration has superseded the process in both Coventry and Nuneaton, and at Leyton a change had also to be made, as the effluent water was not rendered sufficiently pure for discharge into rivers.

The lime, chloride of magnesium, and tar process was tried at Aldershot, Edmonton, Grantham, Leicester, Southborough, Taunton, Tottenham, Windsor, and Wimbledon, and is still employed at Edmonton, costing 14d. per head of population per annum, and the effluent is afterwards further purified by irrigation.

The lime and black ash waste process has been tried at Golcar, Leeds, Leyton, and Tonge. One ton of lime and a quarter of a ton of black ash waste is added and mixed with 1,000,000 gallons of sewage, and allowed to settle. It is at present in use at Leyton, where the cost is found to be 9d. per head per annum. The sludge cannot be sold, and has to be removed from the works by contract.

The ferrozone and polarite and sand process. The writer's attention has been arrested by a new system of treating

town sewage in Acton, which has proved so far successful as to be likely to supersede older systems.

The method is very simple.

1. The solids are rapidly precipitated and the liquid deodorised.

2. The organic matter in solution is removed while passing the effluent through special filter-beds.

The chemical used as precipitant and deodorant is known as "ferrozone," and that used as filtrant is known as "polarite."

The effluent at Acton is the purest, and the sludge is the best in manurial quality yet produced by any system.

The crude sewage flows, along with a proportion of ferrozone precipitant, into a large precipitating tank of 130,000 gallons, of which there are three at Acton, side by side. Subsidence of solids during three or four hours' rest takes place, and then the top liquid is run off from the surface, by means of a floating arm, to the filter-bed, formed of gravel at bottom, polarite filtrant next, and sand on top in layers. After passing through this filter-bed the effluent is bright, clear, and inodorous. The only cleansing of the Acton filter-beds found necessary after twenty months' use was the replacement of two inches of surface sand. The sludge is not deprived of the valuable ammonia of the manure, because no lime is used in the process.

The polarite in the filter takes the place of the land required for other systems of filtration. A few hours' rest effects complete chemical revival of the polarite.

These filter-beds are said to filter sewage effluents effectively, at the rate of a thousand gallons per square yard per twenty-four hours, with better results than can be obtained by land filtration at the rate of one and a half gallon per twenty-four hours, or, in other

words, it is stated that one acre of polarite and sand filter in equal proportions will do better work than 666 acres of land.

The importance of this system of sewage purification has been urged upon the writer strongly by an official engineer, who was sent officially to inspect the process, and had no interest whatever in the system above any other with which he was instructed to make comparison.

The treatment of sewage by the iron process has the special characteristic of being applicable to the dwelling-house drain, or to any portion of a system of drainage, including cesspools. It is stated that nothing unpleasant attends the clearing out of cesspits where this process is used, and that the bulk of their contents is materially reduced by the action of the iron. Sulphate of iron is the chemical adopted, and it is applied in an instrument called the ferrometer, patented in England. This instrument has a glass dissolving tube, in which the chemical is placed and its action observed. The chemical is caused to dissolve in proportion to the number of persons using the drains, and the solution is allowed to mingle drop by drop with the drainage, which it reduces to a black, inodorous, charcoal-like deposit.

Sulphate of iron undoubtedly effects powerful action on sewage matter in a dark drain. Whether it altogether destroys whatever is putrescible in sewage matter, or only delays the process of putrefaction, is a question the writer cannot solve; but certainly the effect it has in breaking up and changing the appearance of sewage can be observed by anyone who chooses to take the trouble to mingle solution of sulphate of iron with any house drainage. Any person is at liberty to apply sulphate of iron to their drainage without infringement of any

patent, but the patent ferrometer affords one of the best methods of applying the process.

The treatment of sewage by intermittent downward filtration has been adopted by numerous towns. Merthyr Tydfil, Kendal, Oakham, Dewsbury, Withington, Hitchin, Croydon, are typical examples of successful sewage disposal by this method. It consists in the alternate transmission of sewage and air through a porous soil. The sewage, when discharged at intervals over the suitable soil, fills the pores with the foul liquid in broken-up, attenuated threads, easily and rapidly attacked by the action of the oxygenated sand or earth, and the sewage, in passing, draws after it streams of air through the pores of the soil, whose oxygen attacks and purifies all that it comes in contact with.

By this process, in numerous experiments, the whole of the suspended matters in the sewage was removed; and in proportion to the rapidity or slowness of the filtration, and depending also on the porous quality of the soil, a percentage varying from eighty-four to ninety per cent. of the putrescible matters in solution was removed by the same process at the same time.

This satisfactory result can seldom be obtained when the rate of filtration exceeds five gallons per twenty-four hours for each cubic yard of porous soil filtering medium, such as sand, or sand and chalk mixture.

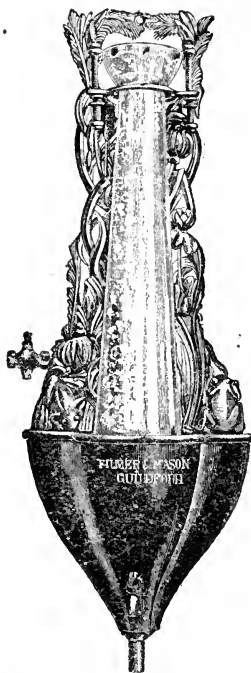

FIG. 14.—Ferrometer.

The purification of sewage in this process is essentially that of chemical action by oxygen, the organic impurities being changed into carbonic acid, water, and nitric acid. The special practical point to be observed in the management of the work is that a constant supply of air be secured, giving abundant intermittent aeration to the filtering porous soil. So long, and only so long, as nitrates are freely formed by the action of the air on the sewage can effective purification occur. In filtering through peaty soils this process is also efficient, but the maximum amount passed in twenty-four hours through each cubic yard must be reduced from five gallons to four gallons.

Mr. Bailey Denton designed and constructed an experimental and practical system of intermittent filtration for the sewage of Merthyr Tydfil, South Wales, 50,000 persons. Twenty acres of sloping porous land, drained from five to seven feet deep, were laid out in four ranges of beds. The sewage, discharged over each range in succession for six hours, flows over the whole of the sloping surface in the time, and, sinking through, draws air after it during the remaining eighteen hours. Vegetables are successfully cultivated on the soil. The whole of the suspended putrescible matters are removed, with ninety per cent., and sometimes as much as ninety-four per cent., of the soluble putrescible matters.

The effluent possesses so high a degree of purity, at all times, as to be fit for admission to the river.

The success of this system decided the local sanitary authorities to provide for the drainage of a large surrounding district, containing altogether one hundred thousand persons. About three hundred acres of land are employed, and this has yielded a return of profit of £400 over all expenditure except rent.

Other instances of the success of intermittent filtration may be found at Kendal, where sixteen acres of land are found amply sufficient for thirteen thousand persons, at a cost of  $1\frac{1}{2}d.$  in the pound on the valuation of the town.

At Oakham, in Rutlandshire, with three thousand persons, the sewage is thoroughly purified on three acres of irrigated filtering ground. The crops are made even to yield a profitable return.

Dewsbury, Yorkshire, a manufacturing town of thirty thousand inhabitants, devotes fifty acres of porous sandy soil for filtration, with ten acres for surface irrigation.

The effluent is found to be the purest part of the river near Dewsbury, owing to the polluting effect of waste dye products from mills up the stream.

Mr. Bailey Denton was the first engineer to introduce this system of sewage disposal; he has had a great many years' experience of its practical working, and states that when the plan is originally designed and executed well, and also maintained and managed with regard to the principles of the process, it cannot fail to prove satisfactory.

When a sufficient area of suitable land is available, the finer particles suspended in sewage may be carried on to the land; but when preliminary precipitation is adopted, the land will purify double the quantity of the clarified sewage.

The treatment of sewage by irrigation on sewage farms is considered the only one yielding any hope of ultimate profit in working. It certainly secures an effluent of the highest purity, and also uses up the manurial value of the sewage for the benefit of the crops grown. It is employed on many farms now in England, in connection with towns, by local authorities, at Bedford, Birmingham, Brackley, Doncaster, Leamington, Wrexham, Wimbledon.

At Birmingham, which has one of the best-arranged irrigation systems in England, the sewage, about sixteen million gallons a day, is first treated with lime, to neutralise the acids, and passed through tanks, where the grosser impurities are deposited; thence it is conveyed by one main channel, and distributed over the land as required for irrigation. The deposited sludge is pumped into channels, and flows to a certain portion of the farm, where, when it dries, after lying a few days, it is trenched into the land, and crops are grown upon it. About forty acres are devoted to sludge treatment each year. The sewage from 560 persons is dealt with and purified thus on each acre of the farm, and is an intermediate system between irrigation, which requires an acre for each hundred persons, and intermittent filtration with preliminary treatment, which requires only an acre for each thousand persons. The crops grown are mangolds, swedes, kohlrabi, market-garden produce, rye grass, cereals, and pasture, the latter yielding 128,000 gallons of milk, value £4,400. The cost of maintenance only demands a rate of  $5\frac{1}{2}d.$  per head of population contributing to the sewage.

As an illustration of the comparative merits of the system of purification of sewage, the report of the Rivers Pollution Commissioners gives the following abstract:—

Process.	Average Percentage of Dissolved Organic Pollution removed.		Average Percentage of Dissolved Organic Pollution removed.
	Organic Carbon.	Organic Nitrogen.	
Chemical process—			
Best result . . .	50·1	65·8	100
Worst result . . .	3·4	0	59·6
Average result . . .	23·4	36·6	89·8
Irrigation—			
Best result . . .	91·8	97·4	100
Worst result . . .	42·7	44·1	84·9
Average result . . .	68·6	81·7	97·7
Intermittent filtration—			
Best result . . .	88·5	97·5	100
Worst result . . .	32·8	43·7	100
Average result . . .	72·8	87·6	100



It must not be lost sight of that no system of purification of sewage is sufficient to warrant the use of any stream, into which the effluent flows, for drinking purposes or town water-supply. But for all other uses we have in irrigation and intermittent filtration ample means of purifying sewage, so as to render it admissible in any quantity into any stream without causing pollution. More than two hundred English towns have adopted these effective systems.

The following standard was recommended by the Rivers Pollution Commissioners for adoption, to determine impurity in waters discharged into streams and rivers:—

Any liquid containing in suspension more than three parts by weight of mineral matter or one part by weight of dry organic matter in one hundred thousand parts by weight of the liquid.

Any liquid containing in solution more than two parts by weight of organic carbon or 0.3 parts by weight of organic nitrogen in one hundred thousand parts by weight.

In the Rivers Pollution Act, 1876, Parliament adopted the recommendations of the Commission but very partially. This Act has proved a failure, and wherever in England river pollution has been stopped this has been effected by process of injunction under the old laws.

At the International Congress in Vienna, where the writer attended as official delegate for the Institution of Civil Engineers of Ireland, the following conclusions, formulated by Professor Frankland, appeared to meet with acceptance or approval:—

That sewage disposal is usually effected with considerable loss when the effluent is purified sufficiently for river outfalls.

That the cheapest method to prevent river pollution is to discharge sewage direct to sea, where the towns are not too distant from the coast.

That chemical treatment of sewage has hitherto not proved successful in purifying the effluent for discharge into rivers.

That the only effectual and practical process of purification is that of passage through land, either by irrigation or intermittent filtration.

That where land is costly one acre is sufficient to purify the sewage from one to two thousand persons by intermittent filtration.

That where land is cheaply obtainable the system of irrigation, combined with suitable cropping and tillage, is preferable, providing that one acre is available for every hundred persons.

That in applying sewage to land it is an advantage that the crude sewage should undergo preliminary chemical treatment.

That the best method for disposing of the precipitated sludge is to drain it on to the land, and trench it in when dry and solid, otherwise it may be pressed into blocks and used as manure.

That no injury to health has ever been discovered in the neighbourhood of the sewage farms or works where irrigation or filtration is carried out in a reasonably proper manner.

It will be observed that in these deductions no reference is made to the ferrozone and polarite process, as that system had not been well before the public at the date the Congress was held.

The midden system, dry earth-closet system, and pail system of disposal, adopted for some towns, give constant daily trouble, create nuisances during removal, and, after all, leave the surface waters of the streets and the slop waters of houses to be dealt with by some system of drainage

and sewerage, and these waters are found quite as unsuitable for discharge into rivers as is the drainage of water-closeted towns.

The Rivers Pollution Commissioners examined and analysed the sewage of a large number of towns arranged on the midden system for excluding solid excreta from the sewers, and also the sewage of a large number of water-closeted towns where all drainage passed into the sewers, with the result as follows in parts per 100,000 :—

	Total Solids in Solution.	Organic Carbon.	Organic Nitrogen.	Ammonia.	Total combined Nitrogen.	Chlorine.	Suspended Matters.
Average of midden towns . . . . .	82.4	4.181	1.975	5.435	6.451	11.54	39.11
Average of water-closeted towns . . . . .	72.2	4.696	2.205	6.703	7.728	10.66	44.69

The Commissioners state that, as a result of their researches, it seems hopeless to anticipate any substantial reduction of sewage pollution by dealing with solid excrementitious matter only.

Since the appearance of the first edition of this work very considerable advance has been made in methods of sewage disposal. Scientific accounts of the modern discoveries of developments in the biological processes of treating sewage by the direct action of the bacteria living and growing therein reads more like a fairy tale than a sober statement of facts. It appears that the real business of the sewage microbe on coming into existence on suitable soil is to break up the atoms of sewage, live and thrive upon them, to be in turn consumed by the neighbouring microbes; it may be some consolation to us, who cannot be expected to give our approval to cannibalism, to learn that these microbes, once supposed to be living animals, are now believed to be living plants. It is not easy to convey any idea of

their extreme minuteness, varying as they do in their dimensions from one 5,000 parts of an inch to one 25,000 parts. Pearmain and Moore, in their book on *Applied Bacteriology*, try to convey some notion of this to our minds by telling us that if a man was magnified as much as is necessary to magnify a microbe in order to render it visible to human sight he would appear to be four miles high—higher than Mont Blanc.

We are told that millions of microbes exist in one drop, and their rate of increase is so rapid that under favourable and unrestrained conditions one microbe would become 16,000,000 in one day! One microbe and its offshoots would weigh  $\frac{1}{25000}$  of a grain in one day's growth, one pound in two days, and 7,366 tons in three days if there was no restraint. Fortunately nature has provided many checks to restrain this tremendous inherent vital activity, or the world itself would be quickly devoured.

This small portion of the fairy tale is told to show that there is an enormous force at our disposal for the destruction of sewage by the energy of these little vegetable scavengers if they are treated properly.

The bacteriological process of sewage disposal is now under practical trial in many places, and is doing good work with the London sewage at the Outfall Station, Barking Creek, and at Sutton, in Surrey, and from the results obtained promises to solve the difficult problem of sewage disposal and to sweep away all the old methods of costly mechanical and chemical treatment.

The principle is applied in various forms which cannot here be compared or dwelt upon at length. Coke breeze, burnt clay, or similar porous material is arranged in a tank or bed, and when sewage is turned on to the surface the organic matters adhere to this material, and the bacteria commence to propagate speedily, covering

the whole surface of the material. The sewage water is drawn off after a sufficient time, air with its large constituent of oxygen is drawn through as the water lowers, fresh vigour is given to the growth and multiplication of the little vegetable scavengers, and they are ready for a fresh supply of sewage food; and so long as this alternate process goes on the destruction of the dangerous elements is ensured, and the waters are finally rendered sufficiently pure to flow into any stream without fear of pollution.

It will be observed that this Septic method is the opposite of every system of Anti-septic or chemical destruction in which the chemicals, such as lime, sulphate of iron, etc., kill the bacteria and living organisms by which the biological method of treatment carries on its work, following nature's simple laws.

The Septic Tank System of Sewage Disposal, as now in full work at Exeter, is a practical application of the biological treatment. It finds favour with practical men. The sewage flows direct into a covered tank holding about eighteen hours' flow, and depositing therein heavy matters in suspension; the lighter matters flow on with the water to coke breeze filter-beds. The discharge is worked automatically by syphons and buckets acting on penstocks, which when one filter is filled turn the flow on to a second empty filter, and empties a third which has had its turn of resting full.

The daily amount treated at Exeter is about 60,000 gallons. The amount of deposit left in tank is moderate and is easily removed. The mechanical gear would seem to offer an element of doubt, though it is simple and has worked well under all conditions of weather.

No odour of sulphuretted hydrogen comes from the filter-beds, and the filtrate or effluent water is bright and clear,

fit to be turned into any stream, and gives no sign of secondary decomposition.

The Septic Tank System thus promises to be of great practical value to villages, small towns, and mansions, where effective sanitary sewage disposal has hitherto proved unattainable at moderate cost.

Adams' patent bacteria bed apparatus is another adaptation of the bacteriological process of sewage disposal which deserves notice; we accordingly give here a plan and section with explanation:—

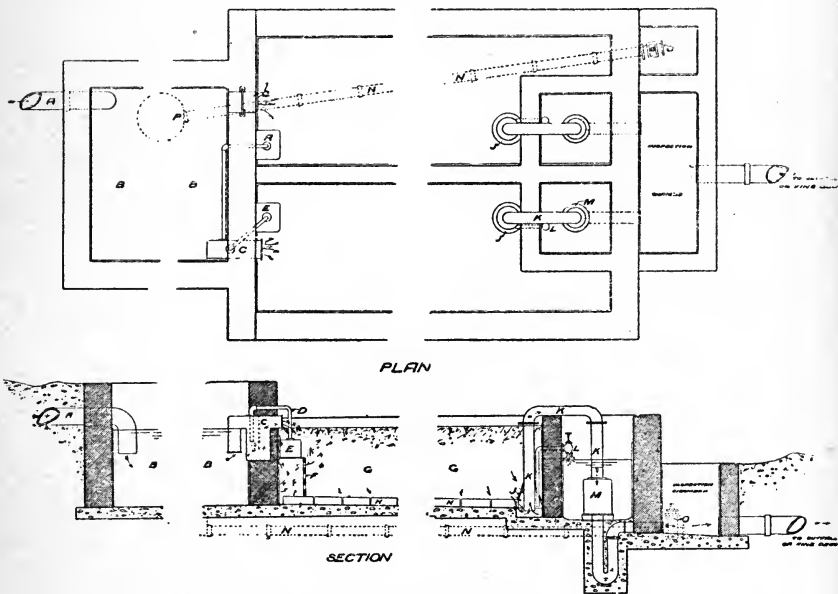

FIG. 15.—Adams' Patent Bacteria Bed Apparatus.

*Adams' Patent Bacteria Bed Apparatus.*—With Mr. Dibdin's contact beds it is necessary to fill a bed, shut off the supply, allow the sewage to remain upon the bed for the desired contact, and then to run the bed off and allow it to stand empty for aeration. The illustration shows

Messrs. Adams' patented apparatus: the supply to a bed is through a metal casting formed as a trap; liquid passes freely through this ordinarily, but is prevented from doing so when air under pressure is forced into the apparatus, air lock resulting. The necessary air is displaced from an attached air dome by the rising liquid in bed. The filling of the bed thus shuts off its own supply. An added volume of air to the feed forces the trap; this added volume of air is transferred from an air dome in the bed, which it is desired to follow. The supply is thus brought from bed to bed. To discharge the beds a timed syphon is used; this is placed in a small chamber, which is filled by means of a tap from the bed; the rate of filling determines the length of contact. Thus if the tank takes two hours to fill, the sewage is held up for contact in the bed for that length of time; the syphon starting automatically then discharges the contents of its own chamber, and through the overdraw pipe that of the bacteria bed. In this way the contact may be fixed to meet the requirements of the sewage, a thin sewage requiring less and a stronger sewage a longer period.

In other modifications the same parts serve for use on the continuous or other systems.

*Description of Adams' Patent Sewage Lift.*—This apparatus for the automatic raising of low-level sewage is actuated by compressed air. The liquid to be raised is ejected from a cylinder—into which it has first gravitated—by this pressure. The illustration shows the lift as installed in a building for raising basement sewage. Water enters the flush tank, discharging from it to the air cylinder; air from the latter is thus displaced and sent through the air pipe to the forcing cylinder; from the latter the sewage is ejected by the air pressure thus directly applied.

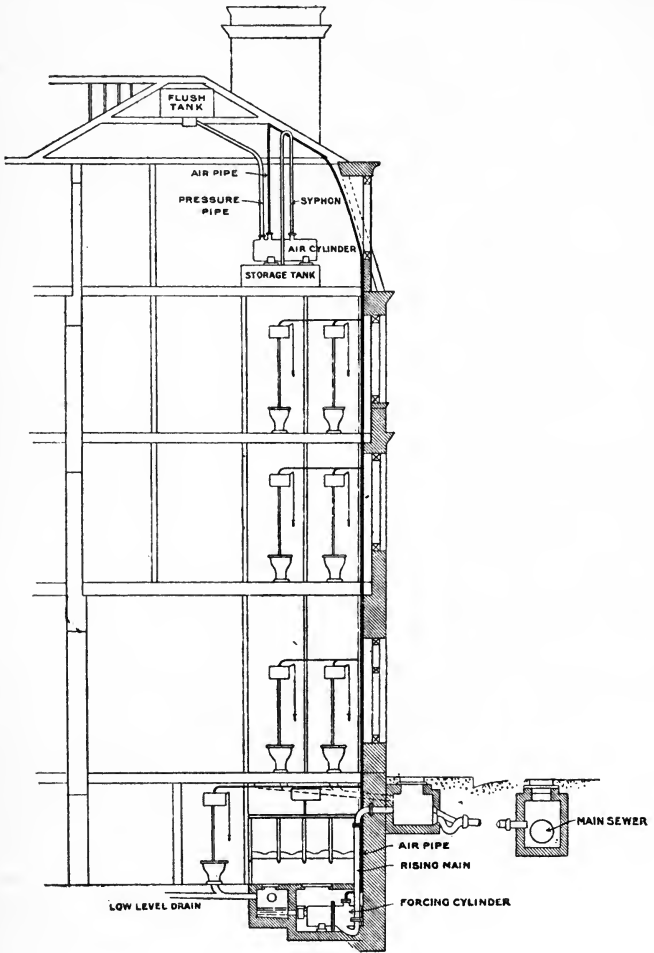

FIG. 16.—Patent Sewage Lift.



*Adams' Patent Flushing Syphons.*—The original deep trap syphon, invented by Messrs. Adams and Co., depends for its action upon the pressure of the air confined between the deep trap of syphon and the rising liquid in tank; when a sufficient pressure is reached the air is forced out through the water seal and syphonic action follows.

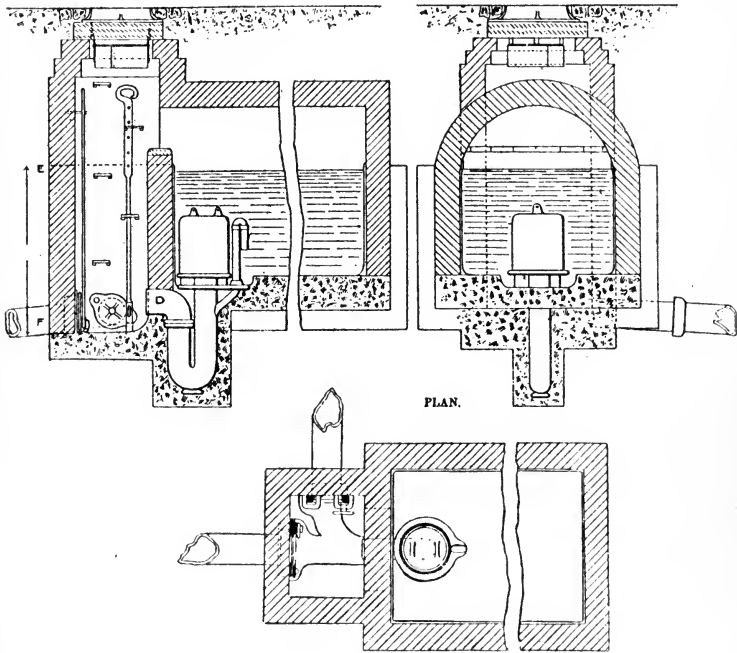

FIG. 17.—Adams' Patent Flush Syphon.

## CHAPTER V.

### SEWERAGE AND DRAINAGE.

PUBLIC sewers generally receive, and should be constructed to carry off as rapidly as possible, rain water from roofs and roads, waste water from houses, liquid and solid excreta, and refuse matters from factories. Such sewers must be large enough to carry off flood waters in exceptionally severe storms, or be provided with storm water overflows.

In some cases two systems of sewers are constructed—one to carry the rain and surface waters of roofs and roads, the other to carry only the waste and soil from dwellings. This is known as the separate system, and has in some instances enabled local authorities to utilise open surface channels and large existing sewers for conveying the rain and surface waters to streams and rivers, while providing, at a minimum of expense, a very perfect system of sewers of small area for the conveyance of house drainage in a concentrated form to the outfall, perhaps on a sewage farm.

It has been shown to be a mistake to suppose that rain water from roofs and roads, thus separated from house drainage, is sufficiently pure to be admitted safely into streams and rivers; analysis shows that the road water of populous towns, thus separated, contains all the elements of danger in almost equal intensity as when mixed indiscriminately in the whole volume of town sewage. The question is one which cannot be settled definitely for universal adoption; but local authorities are supposed to consider and be guided by the particular circumstances of

each district—in some the combined system of sewerage with large sewers of the best form, and in others the separate system of sewerage, will be found to present the greatest advantages for adoption.

We may here remember that old town sewers were constructed and used before the introduction of water-closets, for the purpose of carrying off rain waters and the slop and sink waters from houses, and that in many cases these sewers are quite unfit for water-closet drainage, although they are employed recklessly for the purpose.

Sewers should be laid or built in right lines from point to point; manhole chambers, giving easy access to the sewers, should be built at every point where a change of direction or of gradient occurs. Branch sewers should always enter the main sewer at a manhole chamber, and house drains should enter the sewer, not at right angles, but with a splay or curve in the direction of the current of the sewer. Frequent ventilating openings should also be made.

The fall or inclination for public sewers should be such as to give the sewage a velocity of flow of three feet per second to ensure a proper scour. Frequently it is impossible to obtain the necessary fall to produce this result, and then the engineer has to make the best of his opportunities and secure intermittent scouring by means of automatic flushing. The usual fall for public sewers is found to range between 1 in 250 and 1 in 750, though in some towns the sewer has perforce been laid nearly level, having a fall of only 1 in 5,000, as in Southport, Lancashire.

The ventilation of public sewers is of paramount importance. Many plans have been devised and tested, but the general practical conclusion arrived at by the most experienced engineers is this: that every main sewer should be provided with large effectual openings for ventilation

every hundred yards at least, or eighteen to each mile of sewer, as a minimum provision for ventilation, and that this allowance may be doubled with advantage to public health, no corresponding disadvantage arising but that of the first cost of the ventilating chambers and gratings.

Fifty ventilating openings per mile is not, in my opinion, an excessive provision on town sewers to allow for a certain proportion being out of use, especially if the gradient be unsatisfactory.

When offensive smells are observed to issue from such ventilating gratings the remedy is not found by closing them, but rather by opening additional ventilators, and by taking proper steps to flush and cleanse the sewers, and to provide that the private house drains shall be properly constructed, so as to discharge their contents freshly and directly into the main sewer before putrefactive action has been set up in them.

The adoption of charcoal as a deodoriser for such ventilation gratings over public sewers has been found unsatisfactory. It has been shown that for every square inch of surface outlet ventilator fifty square inches of charcoal, arranged on open trays, should be provided. This charcoal must be kept dry to be of any practical use, it must be frequently changed, and it becomes clogged with dust. This experience has induced engineers and local authorities to disapprove of charcoal for this purpose in public sewerage.

The importance of the ventilation of sewers and drains arises from various causes, which have been admirably classified and explained by Mr. Baldwin Latham.

Heat, he states, is one of the most powerful forces at work in unventilated sewers or drains. The confined air is subjected to repeated expansions and contractions as hot and cold water passes through, so that ordinary water-traps

are totally inadequate to resist the pressure thus brought to bear upon them. Hot water discharged from pantry and scullery troughs, baths, boilers, and factory wastes, into unventilated sewers and drains, compresses the volume of air, and consequently increases the pressure at all points of the system.

If 1,000 cubic inches of air at  $32^{\circ}$  be heated to  $60^{\circ}$ , the volume expands to 1,057 cubic inches; if it be heated to  $100^{\circ}$ , the volume expands to 1,138 cubic inches; and in seeking to expand thus in any unventilated sewer or drain, the water-traps must give way and admit the sewer and drain air to the houses. Every  $20^{\circ}$  increase of temperature increases the volume of air about one-twentieth, if it be free to expand; but, if confined, it increases the pressure in a proportion beyond the power of resistance of ordinary water-traps.

We thus learn the need of ample ventilation to check pressure.

The ebb and flow of sewage also compresses and dilates the air. The pressure of the air is inversely as the space it occupies; therefore every gallon of water entering a sewer must increase the pressure of the air, unless free ventilation is provided for the escape of a corresponding gallon of air. In sudden storms of rain, and where sewers are backed up in seaboard towns by rising tide, this effect and its dangers are greatest.

Strong winds blowing into the open, unprotected mouths of sewers at outfall, or even over open ventilators, cause considerable pressure, and necessitate relieving ventilation at opposite ends of sewers and all along its course, and practically suggest the wisdom of considering the position of outfalls to avoid prevailing winds as much as possible.

The too rapid gradient or fall of a sewer is also a danger, as it may act like a chimney shaft, and cause a

back pressure of sewer air. The "grand fall," so often triumphantly paraded by the owners of a house on a hill, may prove a fatal fall if the drain ends in a cesspool or defective sewer without ample ventilation and other safeguards.

A gentleman who often publicly advocates the necessity for sanitary reform in domestic sanitary arrangements, and resides in a locality where there is no proper system of main drainage, but where many of the house drains have the "grand fall" referred to, and discharge into cesspools overflowing—it may be near wells, etc., in adjoining premises—on a lower level, found his drain choked and requested a plumber to clear it. The drain was found full of grease and could not be cleared without breaking open the pipes, which he was informed were not laid on concrete or with cement joints; the sink in the scullery was fitted with mid-feather trap not cemented in, and there was no grease trap on drain. On the matter being reported, the gentleman stated the drains were inspected some years previously, when a grease trap was recommended, but had not been fixed since. He considered the cesspool system an ideal one, but in the locality referred to it cost £5 to have the cesspool cleaned, and therefore the residents as a rule scarcely ever had it done!

The subject of sewage disposal and public sewer construction belongs rather to the domain of sewerage on a larger scale than plumbers are usually called on to design; nevertheless, it is part of their business to know something of the outfalls at their disposal.

The construction of main sewers is so often placed in the hands of careless contractors, to say nothing of possible errors of design, that such main sewers are often found to

be sewers of deposit, or elongated cesspools, in which dangerous gases are evolved from the decomposing excreta and other sewage matters; and plumbers may take it for granted that in the sewers which they are compelled to use as drain outfalls, dangerous air exists, and they should protect their work accordingly by every means placed within their reach.

When engaged to fit up the general plumbing and sanitary appliances in a house the plumber should also be competent to claim and carry out the laying of drains to the outfall, and be accountable for all such important work at the house side of the sewer.

The soil-pipes, waste-pipes, and sanitary appliances may be perfect of their kind, yet if the house drains are badly arranged or badly laid all the skill and care of the plumber will be wasted.

It is therefore a matter of prime importance that the principles governing work of this kind should be known to plumbers. Some may consider, perhaps, that laying earthenware drains does not pertain to the plumber's trade; but master plumbers can avoid neither the work nor the responsibility which is connected with it.

Cast-iron drains are largely used in America, and are being strongly advocated in this country. Wherever they are adopted the plumber must necessarily be prepared to supply and fix them, if he intends to continue to hold his position.

The questions to be considered and settled in connection with any system of house drains will be taken in the following order:—

The gradient and dimensions.

The material.

The construction and arrangement.

The question of proper fall or gradient for house drains is not sufficiently considered or understood. It is most important, as the proper discharge of the foul drainage and consequent purity of the house drain is mainly dependent on a proper fall. In ordinary house drainage it is usual to specify for "the greatest fall attainable"; yet what a contractor may choose to understand as "the greatest fall attainable" may be quite insufficient to render the drain either satisfactory or safe. When possible, and when he is sufficiently paid for the time involved in the work, the sanitary engineer who specifies for the drain should ascertain the limits of the available gradient from summit to outfall, and lay down definitely the fall which the contractor shall be bound to secure, or, failing to secure, shall be required to report the difficulty to the engineer, or be held liable for consequences.

The rule of thumb of "get all the fall you can" is often right, but one should know the point at which one fails to secure sufficient fall for efficient drainage, when special flushing arrangement becomes essential.

The velocity of flow in circular pipe-drains is the same, we may have seen, whether running full or half full; but in house drains we have the flow running intermittently, sometimes at the depth of one inch, and seldom more than quarter full, as house drains are generally provided much too large for their work. When drains run less than half full their velocity of flow decreases, and their efficiency in removing solid matters decreases in proportion. The best results would follow were it possible to arrange a drainage system of circular pipes, always flowing, about seven-eighths or three-quarters full in every part throughout.

As this is not often attainable, it will be well to provide for fall and dimensions mutually adjusted to the work to be done, and to be guided in the determination of gradients



for velocity by the requirements of drains when flowing quarter full, rather than when flowing quite full.

There is a point of flow in all sewers and pipes at which they discharge a larger volume than when flowing quite full. When a circular pipe flows at seven-eighths or three-quarters, the velocity is greater than when flowing full; when at two-thirds, the velocity is less than when flowing at seven-eighths or three-quarters, though still greater than when flowing full. When flowing half full, the velocity is exactly the same as when flowing full, because the contour and area assume the same proportions in each, and therefore the hydraulic mean depth is always the same in both cases. When at one-third, velocity reduces; and at a quarter full it becomes yet slower, as the following tables will show.

The simplest formula for calculating the velocity of flow through sewers or drains under various heads or gradients is this:—

$$V = 55 \sqrt{H \times 2F},$$

in which  $V$  = velocity in feet per minute;

$H$  = hydraulic mean depth;

$F$  = fall in feet per mile.

Multiply the hydraulic mean depth by twice the fall in feet per mile, find the square root of this product, and multiply it by the constant number 55; the result gives the velocity in feet per minute.

Multiply this velocity again by the sectional area in square feet of water flowing; the result gives the discharge in cubic feet per minute.

Multiply this discharge by 6.24; the result gives the discharge in gallons per minute.

Thus, to find the velocity in a 6-inch circular drain

running full and laid with a fall of one foot in sixty feet, or eighty-eight feet in a mile, find the hydraulic mean depth as hereafter explained, which is  $\cdot 125$ ; multiply 88, the fall in feet per mile, by 2, and the product is 176; multiply  $\cdot 125$  by 176, and the product is 22.00; find the square root of 22, which is 4.69042, and multiply this by 55, and the product is 258, or 257.9731 exactly, the velocity in feet per minute—

$$2 \times 88 = 176 \times \cdot 125 = 22;$$

$$\sqrt{22} = 4.69042 \times 55 = 257.9731 = V.$$

Find the section area in square feet of water flowing as hereafter explained, which is  $\cdot 1963$ , and multiply this by the velocity, and the product is the discharge in cubic feet per minute—

$$\cdot 1963 \times 258 = 50.6454 \text{ cubic feet per minute};$$

and again—

$$50.6454 \times 6.24 = 316 \text{ gallons per minute.}$$

The hydraulic mean depth or mean radius of pipe, drain, or sewer, no matter what shape its section may be, is found by dividing the sectional area in feet of the actual water flowing, by the length of the wetted perimeter in feet (the wetted perimeter being that portion of the conduit in contact with the flowing water).

The hydraulic mean depth can be found already calculated and set out in published tables. It will be easier and safer, as a general rule, to depend on such tables for hydraulic mean depth, area, velocity, and discharge, than to work out the results; but as the tables differ somewhat, owing to the use of different formula in their preparation, it will be well to be able to check such calculations for accuracy in important work. The writer hopes to explain the process clearly, and also to give many useful tables for plumbers in this volume.

The table of co-efficients is here given for practical use for calculating hydraulic mean depth, as hereafter explained.

XX.	C.	XX.	C.	XX.	C.	XX.	C.
·01 ...	·00133	·26 ...	·162	·51 ...	·403	·76 ...	·640
·02 ...	·00375	·27 ...	·171	·52 ...	·413	·77 ...	·649
·03 ...	·00685	·28 ...	·180	·53 ...	·423	·78 ...	·657
·04 ...	·01054	·29 ...	·189	·54 ...	·433	·79 ...	·665
·05 ...	·0147	·30 ...	·198	·55 ...	·443	·80 ...	·673
·06 ...	·0192	·31 ...	·207	·56 ...	·453	·81 ...	·681
·07 ...	·0242	·32 ...	·217	·57 ...	·462	·82 ...	·689
·08 ...	·0295	·33 ...	·226	·58 ...	·472	·83 ...	·697
·09 ...	·035	·34 ...	·235	·59 ...	·482	·84 ...	·704
·10 ...	·041	·35 ...	·245	·60 ...	·492	·85 ...	·711
·11 ...	·047	·36 ...	·254	·61 ...	·502	·86 ...	·718
·12 ...	·053	·37 ...	·264	·62 ...	·512	·87 ...	·726
·13 ...	·059	·38 ...	·274	·63 ...	·521	·88 ...	·732
·14 ...	·067	·39 ...	·284	·64 ...	·531	·89 ...	·738
·15 ...	·074	·40 ...	·294	·65 ...	·541	·90 ...	·744
·16 ...	·081	·41 ...	·303	·66 ...	·551	·91 ...	·750
·17 ...	·088	·42 ...	·313	·67 ...	·559	·92 ...	·755
·18 ...	·096	·43 ...	·323	·68 ...	·568	·93 ...	·761
·19 ...	·104	·44 ...	·333	·69 ...	·578	·94 ...	·766
·20 ...	·112	·45 ...	·343	·70 ...	·587	·95 ...	·770
·21 ...	·120	·46 ...	·353	·71 ...	·595	·96 ...	·775
·22 ...	·128	·47 ...	·363	·72 ...	·605	·97 ...	·778
·23 ...	·136	·48 ...	·373	·73 ...	·614	·98 ...	·781
·24 ...	·145	·49 ...	·383	·74 ...	·623	·99 ...	·784
·25 ...	·153	·50 ...	·3927	·75 ...	·632	·100 ...	·7854

To calculate the hydraulic mean depth of any drain it is first necessary to ascertain the sectional area of water flowing. In circular pipes, with which plumbers almost exclusively are concerned, this is found by multiplying the square of the diameter by certain co-efficients, or proportional decimals, constant to the ratio of the versed sine, divided by the diameter.

The formula is—Diameter<sup>2</sup> × C (as per table); XX = the versed sine (GH) divided by the diameter of the circle; and C = the constant number or co-efficient placed opposite in table.

If we have a 36-inch sewer running three-quarters full, we find the sectional area thus: Measure the

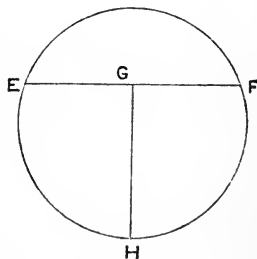

FIG. 18.

versed sine (GH), which is the greatest depth of the water, 2.25 feet, and divide it by the diameter, 3 feet; we have then .75; opposite .75 in table we find the co-efficient .632; now square the diameter, 3 feet =  $3 \times 3 = 9$ , and multiply  $9 \times .632$ ; the result is 5.688 square feet, which is the sectional area of water flowing.

$$3^2 \times .632 = 5.688 \text{ square feet.}$$

When the sectional area of water flowing has been thus obtained, divide into it the length of the wetted perimeter in feet, and the quotient will be the hydraulic mean depth.

To find the hydraulic mean depth of a 6-inch circular drain-pipe running half full the sectional area is first found thus:—

Divide the versed sine (GH = 3 inches) by the diameter 6 inches, = in decimal fractions of a foot .25 and .5 respectively—

$$\frac{.25}{.5} = .25 \div .5 = .5.$$

The constant C (in table) opposite .5 = .3927; now square the diameter in feet =  $.5^2 = .25$ , and multiply  $.25 \times .3927$ , and the product gives the sectional area of water flowing, viz. .098175.

Now proceed to find the length of the wetted perimeter in feet, which, in the case of drains running half full, is equal to half the circumference. The circumference of any circle is found by multiplying the diameter by 3.1416; therefore  $.5 \times 3.1416 = 1.5708 \div 2 = .7854$ , the length of the wetted perimeter in feet.

Now, having found the sectional area = .098175, and the length of the wetted perimeter = .7854, divide the area by the perimeter—

$$.098175 \div .7854 = .125 = \text{hydraulic mean depth.}$$

The same when the drain is flowing full and half full.

USEFUL TABLE OF HYDRAULIC MEAN DEPTH OF CIRCULAR DRAIN.

	Full.	Three-quarters full.	Two-thirds full.	Half full.	One-third full.	Quarter full.
4-inch .	·0835	·1006	·0970	·0835	·0621	·0489
5-inch .	·1042	·1315	·1216	·1042	·073	·064
6-inch .	·125	·1508	·1456	·125	·0931	·0733
9-inch .	·1875	·2263	·2183	·1875	·1396	·11
12-inch .	·25	·3017	·2911	·25	·1862	·1466
15-inch .	·3125	·3771	·3639	·3125	·2327	·1833
18-inch .	·375	·4525	·4367	·375	·2793	·2199

USEFUL TABLE OF SECTIONAL AREA IN SQUARE FEET OF WATER IN CIRCULAR DRAIN.

	Full.	Three-quarters full.	Two-thirds full.	Half full.	One-third full.	Quarter full.
4-inch .	·0873	·0762	·0618	·0436	·0255	·017
5-inch .	·1363	·1096	·0972	·0681	·0391	·0267
6-inch .	·19634	·158	·139	·09817	·0573	·0384
9-inch .	·4418	·3554	·313	·2209	·1289	·0864
12-inch .	·7854	·6318	·556	·3927	·2292	·1535
15-inch .	1·227	·9873	·869	·6135	·3581	·24
18-inch .	1·767	1·422	1·25	·884	·5157	·3455

USEFUL TABLE OF INTERNAL CIRCUMFERENCES OF CIRCULAR DRAINS IN FEET.

4-inch	5-inch	6-inch	9-inch	12-inch	15-inch	18-inch	} diameter. = circumference.
0·333	0·4166	0·5	0·75	1·0	1·25	1·5	
1·0471	1·3088	1·5708	2·3562	3·1416	3·927	4·712	

USEFUL TABLE GIVING INCHES IN DECIMALS OF ONE FOOT.

12 inches . . .	1·0	5 inches . . .	·4166	$\frac{1}{8}$ inch . . .	·0104
11 inches . . .	·9166	4 inches . . .	·333	$\frac{2}{8}$ inch . . .	·0208
10 inches . . .	·8333	3 inches . . .	·25	$\frac{3}{8}$ inch . . .	·0312
9 inches . . .	·75	2 inches . . .	·1666	$\frac{4}{8}$ inch . . .	·0416
8 inches . . .	·666	1 inch . . .	·0833	$\frac{5}{8}$ inch . . .	·0521
7 inches . . .	·5833			$\frac{6}{8}$ inch . . .	·0625
6 inches . . .	·5			$\frac{7}{8}$ inch . . .	·0729

With this table, if we measure a versed sine or a peri-

meter in inches—say, nine and a quarter inches—we find the corresponding decimal fraction of a foot at once:—

$$9 \text{ inches} = \cdot75, \text{ and } \frac{1}{4} \text{ inch} = \cdot0208;$$

$$\cdot75 + \cdot0208 = \cdot7708 \text{ feet} = 9\frac{1}{4} \text{ inches.}$$

Mr. Griffiths, a well-known London sanitary engineer, recommended and adopted, wherever he was able to do so, unusually steep gradients for house drains, in consequence of the intermittent and restricted flow of house drainage. He gave 4-inch drains a fall of 1 in 30 feet; 6-inch, 1 in 40 feet; and 9-inch, 1 in 60 feet; and if these falls could not be obtained he used automatic flushing arrangements.

These steep gradients involve deep excavations and special provisions at the higher levels furthest from outfall, which considerably add to expense; but, without further questioning such skilled recommendations, the writer must state that his practice in many hundreds of houses has fully confirmed a theory he adopted many years ago, that to determine the maximum fall required for house drains we need only multiply the diameter of the drain in inches by 10. This rule cannot very easily be forgotten. Thus, for a 4-inch drain give a fall of 1 in 40; for a 5-inch drain, 1 in 50; for a 6-inch drain, 1 in 60; for a 9-inch drain, 1 in 90.

It is a remarkable fact, which the writer has not seen pointed out elsewhere, that this ratio holds good in all sizes from three inches to a hundred and twenty inches in diameter; but, unfortunately, such good gradients and velocity cannot always be obtained either in town sewers or in house drains.

This decimal system of gradients yields in circular drains a velocity of over four and a half feet per second running two-thirds full, and of over three feet per second running

only one quarter full—amply sufficient for all house-drain work.

In order more clearly to show the effect of decimal gradients we have calculated the velocities in this table by Beardmore's formula:—

Diameter.	Fall per Mile.	Gradient.	Velocity in Feet per Minute.					
			Full.	Three-quarters full.	Two-thirds full.	Half full.	One-third full.	Quarter full.
4 inches	132	1 in 40	256	282	278	256	222	198
5 inches	106	1 in 50	258	280	277	258	222	198
6 inches	88	1 in 60	258	283	278	258	222	198
7 inches	75	1 in 70	258	283	277	258	222	198
8 inches	66	1 in 80	258	283	277	258	222	198
9 inches	58	1 in 90	256	281	277	256	222	195
10 inches	52	1 in 100	256	280	277	256	222	195
12 inches	44	1 in 120	258	283	277	258	222	198

Mr. Baldwin Latham, calculating from Weisbach's more elaborate formula, gives a somewhat higher velocity in his valuable work on Sanitary Engineering, but the ratio of the velocity to the decimal gradients is shown to be the same throughout:—

Feet.			Feet.		
4 inches	1 in 40	=278	16 inches	1 in 160	=278
6 inches	1 in 60	=279	18 inches	1 in 180	=278
8 inches	1 in 80	=278	20 inches	1 in 200	=278
9 inches	1 in 90	=279	25 inches	1 in 250	=278
10 inches	1 in 100	=279	30 inches	1 in 300	=278
12 inches	1 in 120	=278	36 inches	1 in 360	=278
14 inches	1 in 140	=271	40 inches	1 in 400	=278
15 inches	1 in 150	=278	60 inches	1 in 600	=278

We shall be on the safe side, therefore, in following Beardmore's simple formula and the decimal gradients for house drains as the maximum fall.

VARIOUS TABLES OF DISCHARGES, VELOCITIES, AND FALLS.

Mr. Bailey Denton, C.E., in his advanced work on Sanitary Engineering, gives the following figures, which appear very simple and clear:—

Velocity—		3 Feet per Second. 180 Feet per Minute.	4½ Feet per Second. 270 Feet per Minute.		6 Feet per Second. 360 Feet per Minute.	
Diameter.	Fall.	Gallons per Minute.	Fall.	Gallons per Minute.	Fall.	Gallons per Minute.
4 inches	1 in 92	96	1 in 40	144	1 in 23	192
6 inches	1 in 130	216	1 in 61	324	1 in 34	432
9 inches	1 in 207	495	1 in 92	742	1 in 51	990
12 inches	1 in 276	876	1 in 122	1314	1 in 69	1752

Mr. Baldwin Latham, C.E., represents the velocities in house drains, calculated by Weisbach's formula, to be as follows in feet per minute with various given falls:—

RUNNING FULL AND HALF FULL.

Falls of 1 Foot in—	20	30	40	50	60	70	80	90	100
Diameter.									
4 inches	395	322	278	246	226	209	194	152	172
6 inches	481	395	342	307	279	257	289	225	213
9 inches	582	481	418	375	343	317	296	279	264
12 inches	664	551	481	432	395	366	342	322	306

But as house drains frequently run only quarter full, with greatly reduced velocity and scouring effect, the following table will afford a safer indication of the best falls to provide:—

RUNNING QUARTER FULL.

Falls of 1 Foot in—	20	30	40	50	60	70	80	90	100
Diameter.									
4 inches	280	230	198	176	160	150	138	126	112
5 inches	366	255	221	198	180	166	155	145	137
6 inches	...	280	240	215	198	180	170	160	150
9 inches	...	...	296	264	242	220	209	195	185
12 inches	...	...	...	300	275	250	240	225	212



The depths of water flowing quarter full in 4-inch, 6-inch, 9-inch, and 12-inch drains are respectively one inch, one and a half inch, two and a half inches, and three inches, which explains differences in velocities.

A gradient of 1 in 35 gives a velocity, according to Weisbach's formula, of 298 feet per minute in 4-inch diameter pipe flowing full or half full; 1 in 60 = 279 feet, in 6-inch pipe; 1 in 100 = 264 feet, in 9-inch pipe; 1 in 250 = 213 feet, in 15-inch pipe; 1 in 300 = 213 feet, in 18-inch pipe.

To obtain a velocity of three feet per second in circular sewers the following falls should be given, according to the same formula:—

15 in.	18 in.	21 in.	24 in.	30 in.	36 in.	48 in.	diameter.
1 in 350	400	500	550	700	750	1,000	gradient.

The following falls given to 4-inch, 6-inch, 9-inch, and 12-inch circular drain-pipes, running full or half full, being ordinary sizes in use, will produce the following velocities in feet per second:—

4-inch .	1 in 200 = 2 ft. ;	1 in 90 = 3 ft. ;	1 in 50 = 4 ft. ;	1 in 30 = 5 ft.
6-inch .	1 in 300 = 2 ft. ;	1 in 130 = 3 ft. ;	1 in 70 = 4 ft. ;	1 in 50 = 5 ft.
9-inch .	1 in 450 = 2 ft. ;	1 in 200 = 3 ft. ;	1 in 120 = 4 ft. ;	1 in 75 = 5 ft.
12-inch .	1 in 600 = 2 ft. ;	1 in 260 = 3 ft. ;	1 in 160 = 4 ft. ;	1 in 100 = 5 ft.

The length of drain to which this calculation applies correctly can be found by multiplying the velocity by the fall. Thus, the calculation for a 9-inch sewer with a fall of 1 in 200 and a velocity of 3 feet applies to a length of 600 feet— $200 \times 3 = 600$ ; the calculation for a 6-inch sewer with a fall of 1 in 50 and a velocity of 5 feet applies to a length of 250 feet— $50 \times 5 = 250$ .

As to the proper size of drains for dwelling-houses there still exists much misapprehension. It is commonly held

that the larger the drain the better. Let us consider the question.

Take full-sized models in zinc of 4-inch, 6-inch, 9-inch, and 12-inch drains, about two feet long each, and closed staunchly at each end with sheet glass. Pour an equal quantity of water—say two gallons—into each, and the varying depth of water in each will show conclusively that any ordinary water-flush must carry solids better, and clear out a drain of small diameter with more power, than when it is spread across the shallow section of a large drain. The power of carrying off solids with equal amounts of water is evidently much greater in a 4-inch than in a 6-inch drain, and in a 6-inch than in a 9-inch drain, because the water is deeper and the friction surface is less extended in the smaller drains.

Private house drains in towns usually consist of two sections quite distinct.

The first section is that generally provided, laid by, and under the direct control of the sanitary authority, from the public sewer across under the roadway and up to the outermost wall of the premises, inside which limit the sanitary authority does not usually carry the drain.

The second section is that laid by and under the control of the occupier or owner of the houses and premises, beside, around, or under the houses, as circumstances require.

Under section one it is very important that the proper size of house drains should be determined and adopted in towns and cities under local authority.

In one city, containing more than 25,000 houses in about 130 miles of streets, with a population over 250,000, there are about 100 miles of 9-inch diameter connecting house drains (exclusive of main sewers) laid by and under the

control of the sanitary authority across under the roadways from the main sewers to the houses.

The length of private house drains and branches beside, under and around houses, extends to many hundred miles in addition; but we are now only dealing with the section under the control of the sanitary authority.

Now, the internal surface area of this 100 miles of 9-inch drain amounts to 1,188,000 square feet; it is coated with foul matters and constantly giving off exhalations to the air in the drain. If instead of 9-inch diameter drains the authorities had adopted 6-inch diameter, which would be even larger than necessary, the internal surface area would be reduced to 792,000 square feet, and that smaller surface would be less foul, owing to the more effectual changing thereof by the water flushing more completely.

By using 9-inch (which gives 50 per cent. too large a diameter) instead of 6-inch drain an unnecessary and mischievous excess is added of 400,000 square feet of foul surface, seldom, if ever, properly flushed and scoured on the upper section, and constantly giving off foul exhalations to the air in the drain.

Again, the manipulation of 100 miles of 9-inch drains is very much more laborious than with 6-inch drains. Nine-inch drain weighs about ninety pounds per yard, and 6-inch drain fifty-six pounds, giving a total difference in favour of using 6-inch drain of 2,670 tons dead weight—absolutely a useless and mischievous waste of energy. One man can lay as much 6-inch drain as two men can lay 9-inch drain.

The difference in cost of 100 miles of 6-inch and 9-inch drain is well worth attention also.

The first cost of the drains—sea freight, land cartage, warehousing, accidental breakage, workmen's time handling

and laying, excavation of trenches, refilling and packing trenches, cement concrete foundations, cement joints—all cost much less for 6-inch than for 9-inch drains. An estimate shows that the saving effected in 100 miles of drain would be a capital sum of £25,000, besides the more important saving of human life and health.

The importance of forming a hard, unyielding foundation for the drain should never be forgotten. Concrete formed of one part Portland cement to six parts clean coarse gravel, laid in a layer at the bottom of trench

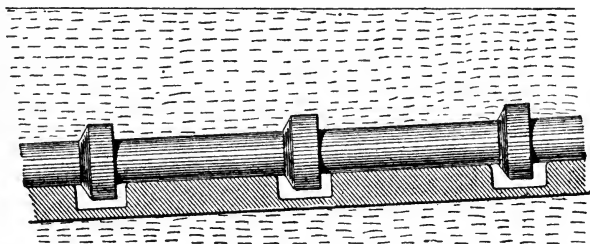

FIG. 19.—Drain pipe resting, supported throughout, on foundation.

(between two boards afterwards removed), three inches deep by nine inches wide on ordinary ground, or six inches deep by nine inches wide on soft, yielding ground, will form a sound foundation. In the latter case the concrete is laid in two layers each three inches deep. It should be given the proper fall equally throughout, as carefully determined beforehand. The drain should not be laid until the concrete has set hard. As the laying of drain proceeds, cuts or hollows, partly across concrete, are sometimes made about two inches deep, and only sufficiently wide to receive the sockets of the pipe drain in such a manner that they shall lie over and in the hollows without touching any part, thus distributing the weight on each length of drain resting

on the hard foundation, instead of allowing the whole weight of drain to press on the sockets, while from socket to socket the drain hangs unsupported, pressed on by the weight of earth above. Where the drain is laid with its sockets only resting on the concrete foundation, which is the usual course adopted, it becomes necessary to pack concrete between the under portion of the drain and the foundation so as to support it throughout. By this method the work can be done quicker, and the concrete foundation is not weakened or shaken by cutting hollows across for the sockets.

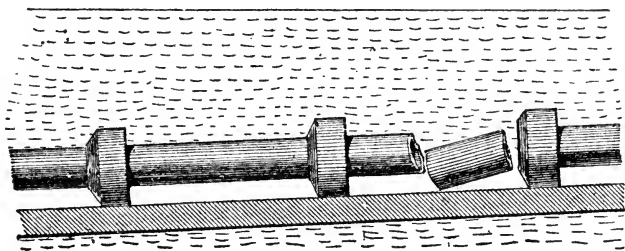

FIG. 20.—Drain sockets resting on foundation ; drain pipe unsupported.

If an unyielding foundation is not formed the drain will sink at certain points, forming dips or festoons underground, which cause stoppage eventually. These points have been noted often, yet sanitary authorities permit the continuance of the ancient defective and dangerous system. The chief difficulty in securing sound drains lies in the fact that they are laid and hidden underground. The aim of plumbers should be to bring them to the light, and so to arrange their drainage that each portion shall be within easy inspection and cleansing distance.

There is no valid defence for the dangerous practice of laying drains dry without staunch joints. Drain-layers, when asked why this is done, say it is in order that the

pipes may not have to be broken when they are removed or altered!

Drains ought to be laid down with the object of fulfilling their purpose of being sound and staunch to carry drainage safely for the health of the householders, rather than with the ulterior object of removing the pipes safely at remote periods to the risk of health in the meantime.

Perhaps the open joints may drain the subsoil, but if they admit subsoil water in wet seasons they will allow the escape of liquid sewage to saturate the soil in dry seasons, and at all times permit the escape of sewer air in

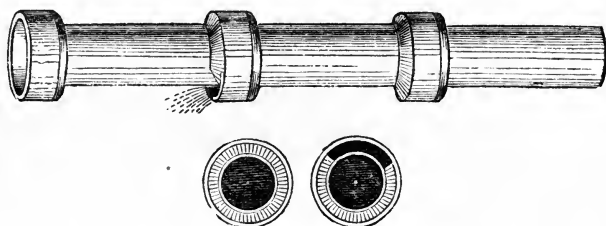

FIG. 21.—Leaking joint and staunch joint.

a dangerous manner. Medina or Portland cement with fine sharp sand makes the best drain joint, provided that cement-soaked gaskin be first well packed round end of joint, to hold the pipe concentric in the socket, and to prevent possibility of cement oozing into the drain and forming a hard lump inside.

The insufficiency of clay or soft yielding material for jointing has been clearly demonstrated, but it is still tenaciously defended by many professional men on the ground that clay yields if unequal pressure comes on any part of the drain, and thus saves the pipe from fracture.

Here we actually find the dangerous elements of bad foundation expected and calculated upon. With good

foundation the drain could not yield, even with clay joints. We find the careless filling in of ground over pipes so as to cause unequal pressure looked for; and we find apparent forgetfulness of the fact that if a drain sinks or falls below its true level or inclination it is no longer a safe and reliable drain, but contains, whether fractured or not, dips or hollows which retain the drainage dangerously, and therefore such drain ought to be removed.

Clay will of necessity wash away out of the joints, as little by little the passing water disintegrates it. Medina or Portland cement is the best, the easiest obtained, and the most simply applied material for earthenware drain joints.

The dangers of this open-joint system are very serious.

1st. The open joints allow the escape of the water which is carrying the solids along, a portion escaping at each opening into the surrounding earth, till the liquid remaining is insufficient to carry on the solids, and they are deposited in the drain, and eventually cause a stoppage, which cannot perhaps be cleared until the drain is opened up.

2nd. The soil surrounding the drain becomes saturated with liquid sewage, which decomposes and becomes dangerous.

3rd. The drain is more liable to settle unequally, making hollows underground in which solids accumulate.

4th. The three or four joints nearest to the house under the coal-vault or scullery, being open, allow the foul sewer air to be forced rapidly through them into the house, and thus, owing to the rarefied condition of the house air, the foul air is pressed in day and night, unsuspected and in large quantities.

The discharging or sewer ends of the pipe drain under roadways are built into the walls of the public sewer, and these sewer walls are found sometimes so close to the outer

walls of the coal-vault adjoining the scullery as to appear but one wall.

If breaches occur in these cases, caused either by too careless workmen or by too careful rats, the dangerous effect will be the same in either case.

Instead of allowing a mason to build well or ill, according to his humour, round the drain-pipe at its outfall through the main sewer wall, special glazed earthenware blocks should be used in each case, built carefully and neatly into the wall, and the drain should then be laid from them towards the house.

These blocks should be splayed to deliver the drainage in the direction of the main sewer current.

One most important point in connection with this subject is the proper point or position in front of the houses to which the drain should be laid by the sanitary authority, and left ready for the house drain to be connected with.

In the majority of cases coming under the author's observation the drains are laid in from the public sewer to the coal-vault adjoining, and opening direct into the scullery under the hall steps, and therefore in direct, unbroken connection with the kitchen and the dwelling.

Many deaths and much illness have been caused by this dangerous position for entrance of drains, taken in connection with the open joints on the drains. Rats frequently make burrows along the outside of pipe drains at this point to get from public sewer into houses, admitting the foul air also, which neither cat nor trap can catch.

The law or the sanitary authority should require all drains to be brought into the open areas in front of houses, and should forbid all direct drain connection under any vaults having direct covered access to the houses.

That interceptor traps are required on the lines of drain,



at some point before they reach the houses, is now generally admitted. If interceptors choke the fault lies in their over-large size, bad form, defective fitting, or insufficient flush, combined with the total neglect of observation on the part of the householder. There are now several forms of interceptor which in 6-inch and 4-inch sizes will clear every time an ordinary flush is used; nevertheless they should be fixed and arranged so that they can be easily inspected, and so that any serious stoppage will reveal itself at once on the surface. The fact that the drainage of all the houses in the streets on higher levels must pass by the mouth of your house drain, and that possibly this drainage is further polluted by the drainage from fever hospitals, which also discharges into the public sewers, ought to afford sufficient reason for the importance of placing intercepting sewer-gas traps on private house drains. Their absence frequently allows infectious diseases to spread from house to house; indeed, without interception and thorough ventilation a system of supply for conveying infected drain air into houses exists, similar to that adopted by the waterworks for the purpose of supplying pure water, the only difference being that in the case of polluted sewer air the pipes are nine, six, and four inches in diameter, instead of half an inch, and the supply is unrestricted. Householders can have any amount of dangerous sewer air, but pure water must be very carefully and sparingly used, or the water inspector will cut off the supply at seven days' notice!

The diameter of interceptors frequently corresponds with the diameter of the drain. Place a 9-inch, a 6-inch, and a 4-inch interceptor of one of the best forms side by side for comparison. You observe the necessarily large, clumsy, unmanageable dimensions of the 9-inch, and the handiness of the 6-inch and 4-inch traps for manipulation, and you can at once see that no ordinary house-flush of two or three

gallons of water would clear the larger trap, and consequently that foul deposits would be likely to remain, decomposing dangerously, and finally will choke the trap and drain unless a flushing tank is in use to discharge large bodies of water at intervals through the drain and trap. The need of these interceptors affords a very strong reason, therefore, in favour of 4-inch and 6-inch drains over 9-inch. The traps standing side by side ought to convince you. Four-inch traps are now used very generally, even when the house drains are of larger diameter. The 4-inch trap retains one gallon; the 6-inch trap retains two and a quarter gallons; the 9-inch trap retains six gallons.

The sanitary authorities do not provide or fix intercepting sewer-gas traps on the section of drain under their control, the ends of the drains are left open, and the option of using interceptors is too often left with the householder; consequently drains are being daily laid without interceptors, or with interceptors of too large size and of bad form, which choke in a short time and are worse than useless. Intercepting chambers should be placed in the open areas in front of every house, easy of access, and furnished with air-tight iron covers and abundant ventilation.

It might be a fair question for consideration whether the sanitary authority or the householder should provide this chamber, but it should be the duty of the sanitary authority to lay the drain from the public sewer in a straight line into the area, in every case also providing and fixing a uniform intercepting sewer-gas trap on the house end, with a splay junction to enable the outer drain to be cleared; while the building of the chamber, together with the house drain and branches, at the house side of the interceptor, should be the duty of the householder. This is common sense; the sanitary authority thus controls and

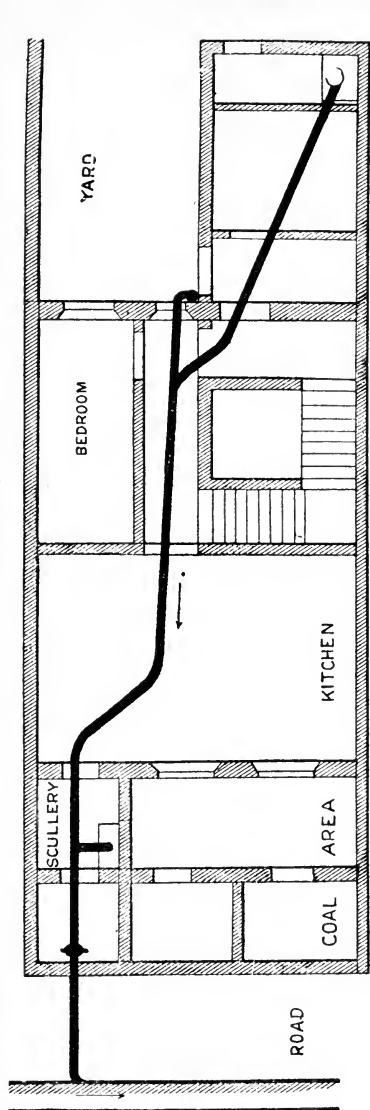

FIG. 22.—Dangerous drain course through scullery.

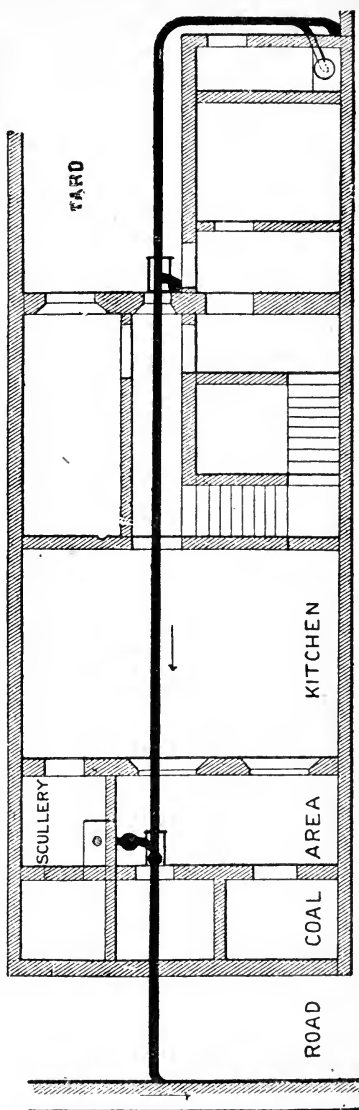

FIG. 23.—Safe drain course from area to area.

prevents escape of the foul air of their sewers into houses, and no dispute as to position of interceptor can arise, as the angles at which house drains join the intercepting chamber may vary, provided it be in the open area.

Nothing, however, that can be done to secure a perfect drain can compensate for the danger incurred by carrying the drain under the scullery and coal-vault to the sewer in place of carrying it across under the open area, or so that an open air space may occur between the house and the public sewer on the line of drain. The diagrams (Figs. 22 and 23) show the common and dangerous course of the house drain, and also the proper and safe course.

If you notice, there is an unbroken line of covered-in connection between the public sewer and the house along the course of the drain in one case, while the open area intervenes in the other case.

A coal-vault under the footway or road adjoining a scullery, with any door or opening between, is always unsafe and often highly dangerous, even without any drain passing under it to the sewer. It is generally preferred as a convenient coal store by the cook, who thus has not to go out into the air to bring in coals from an outer coal-vault. Foul air is always percolating more or less from the public sewers or from leaking gas mains, or from the surface of the street, saturated as it always is with foul matters, through the soil and through the walls and floor and arched roof of such a vault, forced in by the heavier column of cold air outside, upweighing the lighter rarefied column of warm air inside the house.

There should be a rigid law that no vault under the road or footpath should have any opening into a house direct; that every subway vault should only be entered from an open area; and that the wall dividing such vault from the scullery or house should be cemented imperviously, to

exclude from the house all bad or doubtful air that may find access to the coal-vault.

If circumstances are such that the house drain must be laid or remain under the scullery and this vault, the vault should then be concreted, and the doorway built up and cemented, and an entrance or access hole made through the wall dividing this vault from the next vault off the open area.

In a certain locality a strong smell of coal gas was noticed and traced to a coal-vault in the front area where a gas pipe was fixed. The gas company's inspector was sent for, and on arrival said a number of other complaints had been made, and that the smell was caused by gas syphons having been pumped into the main sewer, and when the wind changed, etc., the smell would go away. On being asked if his explanation did not mean that when syphons were not being pumped a constant supply of sewer gas was being forced into the coal-vault and dwellings, etc., he said he would rather not go into that question as he had already been questioned on the point, and his client had threatened to write to the papers and attack the sanitary authorities, getting his name involved in the controversy. Thus are many palpable faults and dangers allowed to remain through self-interest.

The fact still remains that the only proper course for a house drain (when it must pass beneath a house at all) is a straight line from open back yard to open front area, with manhole chambers at each end, and with an interceptor and drain continued from front area chamber to sewer. Pipe drains should never be laid inside old built drains. All saturated foul subsoil should be removed from the premises.

When it is possible the drains should be kept altogether clear of the house, without passing under any portion of the floors whatever.

The strength and impervious quality of earthenware drains is different in every make, and, unfortunately for the contractor who knows his business and desires to use the best quality, this point is generally passed over and considered unimportant. Drain-pipes are drain-pipes—they are hidden underground; and so, from this indifference, many honest contracts for drain work are lost because other contractors employ inferior drain-pipes at less cost. The fact that these cheaper drains have not sufficient strength, and can stand no ordinary test, is not taken into consideration. Nevertheless, the matter is of great importance, and all first-class contractors should urge the matter on the attention of those who seek their services.



FIG. 24.—Earthenware socket drain-pipe, inferior construction.

We here give illustrations of various ordinary drain connections.

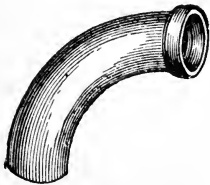

FIG. 25.—Earthenware right-angle bend.



FIG. 26.—Earthenware right-angle bend, with access socket.



FIG. 27.—Earthenware obtuse-angle bend.

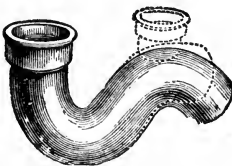

FIG. 28.—Earthenware syphon trap, with vent socket, P shape.

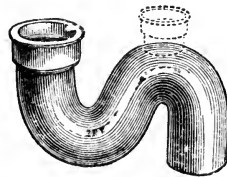

FIG. 29.—Earthenware syphon trap, with vent socket, S shape.

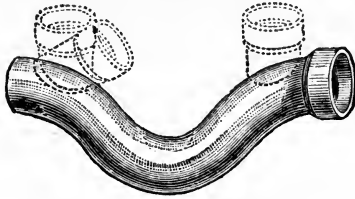

FIG. 30.—Earthenware running trap, with various sockets, an obsolete form.

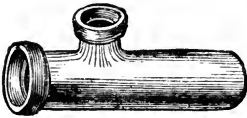

FIG. 31.—Earthenware tee-piece for inspection uses only.

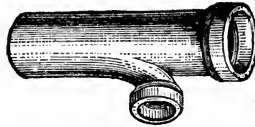

FIG. 32.—Earthenware short splay junction.

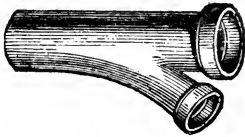

FIG. 33.—Earthenware long splay junction.

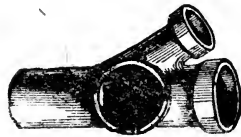

FIG. 34.—Earthenware splay junction, with access socket.

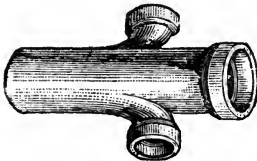

FIG. 35.—Earthenware double short splay junction.

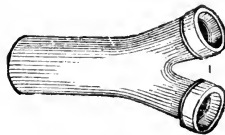

FIG. 36.—Earthenware Y-piece junction.

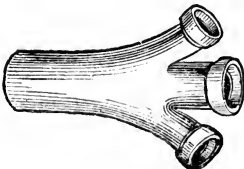

FIG. 37.—Earthenware treble way junction.



FIG. 38.—Earthenware reducing piece.

Many improvements in the manufacture and design of earthenware drains and connections have been introduced to overcome defects and difficulties, but all novelties should be carefully examined and tested before adoption. Plumbers should take pains to keep their knowledge well up to date, bearing in mind that simplicity in construction is better than complication. The late Mr. Buchan, of Glasgow, introduced many practical improvements, which are extensively adopted.

He designed a drain pipe having a small attached block or seat moulded along with the pipe to raise the pipe above the

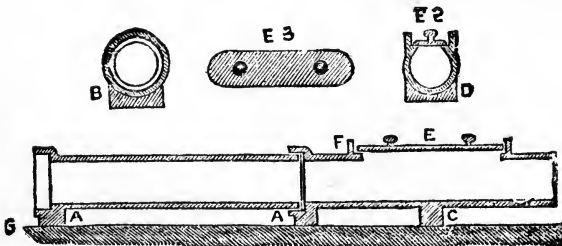

FIG. 39.

foundation and to keep it level and steady. This block, however, adds to cost and weight without securing sufficient advantages in practice to compensate.

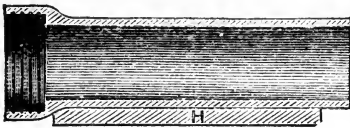

FIG. 40.



FIG. 41.

This illustration shows another modification of Buchan's drains with longitudinal ribs for support, but the writer prefers and recommends the simple form of well-made, well-glazed, well-laid pipe drain.



Buchan's access openings, as shown here, are very useful on drains, and may be freely used wherever drains pass across under areas, yards, or open courts. They should be

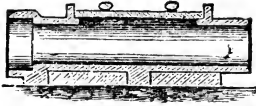

FIG. 42.—Longitudinal section.

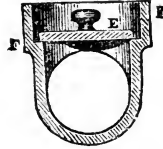

FIG. 43.—Transverse section.

made with air-tight covers; but are not to be fixed inside of houses, lest the covers might be left negligently open after an inspection.



FIG. 44.—Access pipe.

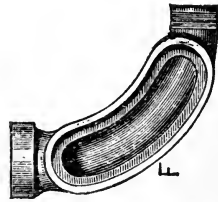

FIG. 45.—Access bend.

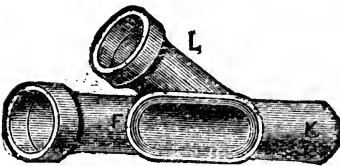

FIG. 46.—Access junction.

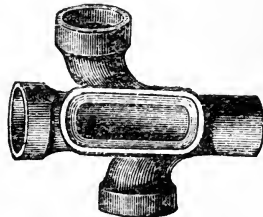

FIG. 47.—Access double junction.

The Armstrong access junctions are also much used in house drainage work, and are very strong, well-made, and suitable; they are to be obtained with junctions at any desired angle.

The subsoil drainage of every house should be considered

by the plumber as of quite equal importance with the water-closet drainage. The basement subsoil should be rendered as dry as possible. If you are called in to replace a leaking or an old-built drain in or around a house, you should first remember that this old defective drain may have been receiving and carrying away the subsoil water, and keeping the basement dry; and that when you lay a perfectly water-tight drain this subsoil water can no longer find vent, and may rise in the floors and up the walls, causing damp and illness, so that your new drain may do more harm than good. You must also not be deceived by a dry appearance of subsoil in fine weather, for when a rainy month comes the water may rise. It will be safe to lay, at a little distance from your new impervious drain, a run of common field drain, with open joints, surrounded by gravel, from back to front, or around the house, always freely open to the air at both ends, back and front, so that any water coming after you leave may be provided for. But you must be very careful never on any terms to connect this open-joint drain with the house drain. You must devise, according to circumstances, a safety disconnecting receiver, or water-trap, in open air, so arranged that, if it should ever run dry, the drain air could not possibly be drawn in through the subsoil drain. There should be a long ventilating grating between the water-trap and the drain, open freely to the air. Remember that you only place the trap and drain as a precaution against subsoil water, which may or may not appear, and you must deal with your subsoil drain accordingly; also remember that air always seeks to enter the house through the subsoil.

Very frequently wells are found in or near houses, in which, if disused, owing to a constant town supply being laid on, water may rise and overflow and saturate the basement, unless some provision for subsoil drainage be made

such as has been described. The common field drain, surrounded by gravel, will be found safer and cheaper than any combined form of drain for the purpose.

The junctions of house-pipes, soil-pipes, waste-pipes, etc., with drains, are very important. The earthenware drains should end outside the house wall if possible, and have a bend always turned upwards to receive the metal or lead house-pipes, which should never enter a drain horizontally. Even when the drain *must* pass through a house, the junctions with it should all be effected outside the house wall in open air spaces, and always be carefully made.

If plumbers are to be entrusted with a control over house drains, they should give proof, both to the public, to architects, and to engineers, of their ability to form a true estimate of the importance of such work, and of the serious responsibility involved in the charge. Drainage should be treated, not as a secondary matter, but as a question concerning life and death.

If the underground drainage of a dwelling be imperfect outbreaks of disease will occur and recur, no matter how perfect that house may be in all other respects. The perfection of any drain depends on the perfection of every part, so that the best and strongest material should be employed for the construction of a drain, especially when it must be laid through and under some portion of the house, as in the case of streets and terraces.

Cast-iron drain-pipes of the weight and description constantly made for high-pressure water-mains for towns are now being used with great advantage for house drainage. Cast-iron drains must be heavy and soundly cast, and cast in the upright position, and should be proved under not less than three hundred pounds per square inch hydraulic pressure; they should be straight, smooth, and truly circular in

bore, results much more easily attained with cast metal than earthenware.

Every connection now made in earthenware can be produced better and quicker in cast iron. The models cost some money, but so do the models for earthenware. We have experienced annoyance and loss, caused by the delays in obtaining from the potteries earthenware drain connections, and especially of any new forms, owing to unexpected failures in the kiln. No doubt we can obtain almost every form of useful connection in earthenware, but this will soon also be the case with cast iron as it comes more into use.

In all cases where pipes are cut across to fit lengths they should be cut even, to prevent gaskin or lead being driven inside the pipe; if cut irregularly, the pipe should not be used.

In laying cast-iron drains the cost of concrete foundations and concrete filling round drain, which is considered necessary for earthenware drains, together with the extra excavation for such concrete, is all saved, and may be carried to the credit of the extra cost of the cast-iron drain, helping to equalise its ultimate cost, when laid, as compared with the earthenware drain.

Each lead joint of a cast-iron drain costs more than a cement joint, but as the iron drain is in 9-foot lengths, one joint absolutely perfect takes the place of three or four joints of a doubtful character in the earthenware drains, and thus the cost is equalised, while the character of the jointing is incomparably improved.

Cast-iron drains may be laid, jointed, and filled in as fast as the trench can be opened and levelled to receive them, often a matter of great importance and sometimes a great saving of expense, as, in case of wet weather when running drains through friable soils, the earth is liable to fall in before the cement in earthenware pipe-joints has time to set.

Cast-iron drains may be safely laid close under or even above the surface of the ground, saving labour in excavation, besides preventing the dangers always attendant on concealment of work, and often securing a more rapid fall.

It often proves most useful to be able to joint two 9-foot or 6-foot lengths of iron drain together, in order to push or draw them through a tunnel, or under some porch or wine-cellar, whose floor cannot be disturbed to allow workmen the space necessary to make the joints of earthenware drains.

Cast-iron drains are not only the strongest and safest, but they are undoubtedly the most suitable drains for plumbers to work and lay down. It is needful to remind workmen

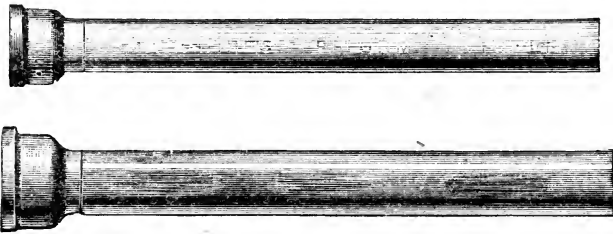

FIG. 48.—Cast-iron drain-pipes.

to make their molten lead sufficiently hot to ensure its running thoroughly round and filling the socket; if poured on only at melting point it solidifies quickly, and does not run well.

Heavy cast-iron drains and all necessary connections are now made four, five, and six inches in diameter. The pipes are made in 9-foot, 6-foot, and 3-foot lengths, and in all intermediate sizes, or the lengths may be chipped round and cut to size with extreme nicety; and the cut lengths can generally be utilised with double sockets or slip collar-joints, preserving accurately the smooth internal bore of the drain. Every pipe and connection should, while still hot from casting, be coated inside and outside with

Dr. Angus Smith's Preservative Composition, formed of pitch, tar, and linseed oil, well melted and mixed. This will prevent corrosion while it lasts, and can be reapplied at any time to the interior of the drain, by brushes made for the purpose.

The writer has tried the Bower-Barff process without success, as blisters of oxide appeared; he much prefers the cheaper process above named.

The joints of cast-iron drains are best when formed with socket and spigot, with projecting ring of metal inside and out respectively, bored and turned in a lathe, so as to form a water-tight joint when pressed together. In making the joints permanently under houses, tarred gaskin or rope yarn should be driven tightly home round the socket, a temporary mould of clay then formed round the mouth of the socket, and very hot molten lead poured in through a hole left in top of the clay mould; the clay is removed and the lead well batted and driven tight by the hammer and packing punch or calking tool all round the socket, care being always taken that the socket pipe is rigidly fixed, so as not to be driven back from the spigot by the blows from the hammer.

Bends and connections cannot easily have their spigots and sockets turned and bored in lathes, so that these joints must be formed with yarn and molten lead well batted, particular care being taken not to drive the socket away before the hammer. The ordinary well-known iron-rust joints may also be used, and relied upon, with cast-iron drain-pipes.

The weight or strength of iron drains, when run underground, may be—for 3-inch, 12 lbs.; 4-inch, 18 lbs.; 5-inch, 25 lbs.; 6 inch, 32 lbs. per lineal foot.

Iron drains come well within the plumber's grasp, and he may claim the laying of them as his right, rather than, as in the case of earthenware drains, a concession or a convenience.

It is a decided advantage, in cases where the plumber has the drains under his control and care, that the materials should be such as he has been trained to work with.

Cast-iron possesses other advantages over earthenware drains. Iron drains can be taken up safe and sound, and both pipes and lead joints can be used again in other positions, or, if not longer required, are value as old metal and old lead. Earthenware drains, we know, when examined are generally found to be already fractured, or must be broken up for removal as valueless rubbish.

Sound earthenware drains are often destroyed by having holes broken into them in order to join on a branch drain,

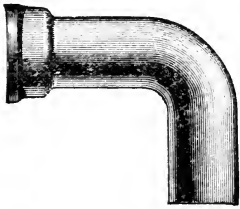

FIG. 49.—Cast-iron bend.

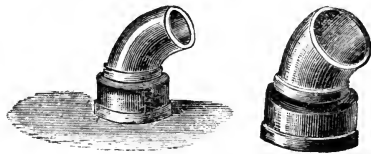

FIG. 50.—Cast-iron short bends.

or to test the pipes, and they are then covered in and left working in that dangerous condition. Plumbers are frequently directed to do this when owners cannot wait for new drains to be laid, and receive blame unjustly afterwards when the drain comes to be relaid. This danger is not likely to occur with cast-iron drains, for it will be easier to provide proper junctions than to drill or cut holes in the iron drain.

Cast-iron manhole chambers, with cast-iron intercepting traps and cast-iron air-tight covers and frames, are provided to intercept or cut off all sewer or cesspool air from the house drain, and cast-iron manhole chambers or inspection openings should be used at every point where a change of

direction or gradient of drain occurs. These manhole chambers and inspection openings may be carried up water-tight to the surface, and are valuable as enabling a complete system of water-tight drains to be laid in positions liable to flooding or backwater from tides. The outfall mouth of drain, if guarded by a water-tight flap-valve, will render the system impervious to backwater, or flooding, or subsoil waters. Iron or earthenware drains for dwellings should be laid in straight lines, and with even gradients from point to point.

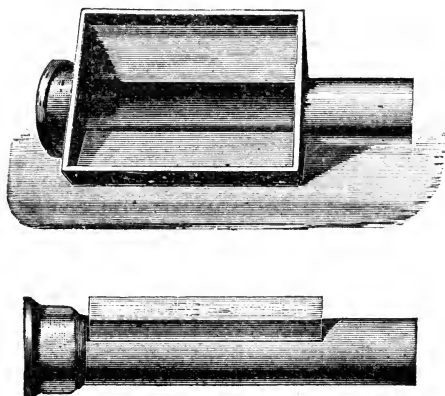

FIG. 51.—Cast-iron manhole chamber bottoms.

Five-inch diameter iron drains for dwellings should be laid with a fall of one foot in every fifty or fifty-four feet, the latter being two inches of fall in each 9-foot length of drain. In every case bends, junctions, and channels across manholes should have a fall of a quarter to half an inch in every foot, accenting the fall in all bends to compensate for and overcome increase of friction.

In laying all kinds of drains always provide inspection openings and splayed junctions, arranged for easy access, to cleanse the drain in every part by drain-clearing



appliances without necessitating the opening of the ground. None of these access openings should be placed inside the house.

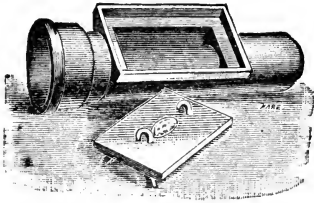

FIG. 52.—Cast-iron access pipe.

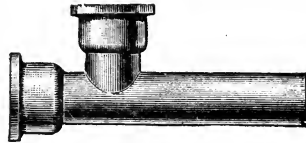

FIG. 53.—Cast-iron inspection tee-piece.

All new house drains should be tested by the hydraulic test before being passed as sound or covered in, and it is now usual to require a second test after the filling in of trenches is completed.

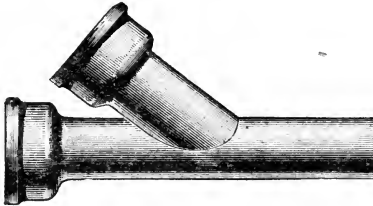

FIG. 54.—Cast-iron splayed junction.

Reducing pieces are made in two ways, both illustrated. In one the slope is made equal all round; in the other, all the slope is thrown on the top of the reducer, so as to

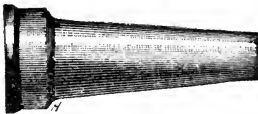

FIG. 55.—Equal slope reducer.

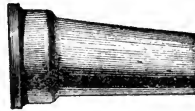

FIG. 56.—Top slope reducer.

ensure a level waterway—an important consideration, when reducing a large drain to suit a smaller interceptor outside.

Slip ferrules, or thimbles, are made to connect two cut pipes as shown.



FIG. 57.—Six-inch ferrule.



FIG. 58.—Four-inch ferrule.

Cast-iron interceptors and traps and cast-iron safety disconnecting receivers for waste-pipes are also necessary.

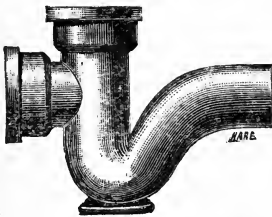

FIG. 59.—Iron interceptor.

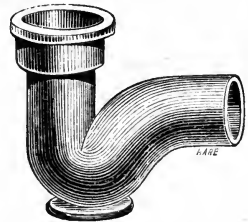

FIG. 60.—Iron syphon.



FIG. 61.—Iron syphon.

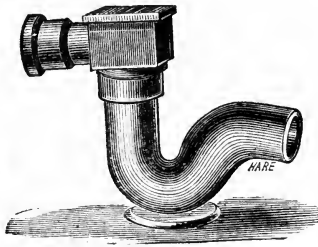

FIG. 62.—Iron disconnector.



FIG. 63.—Iron receiver.

The interception of house drains from the sewers may be very simply and effectually done by any good form of trap on the drain which admits of easy access for cleaning and inspection, has free ventilation to open air and to house drain, and shows the house drainage flowing through, and is small enough to clear with two-gallon flush. The running trap form of interceptor does not fulfil these re-

quirements. If it be provided with a cleaning eye or pipe the house drainage cannot be seen passing, but the solids

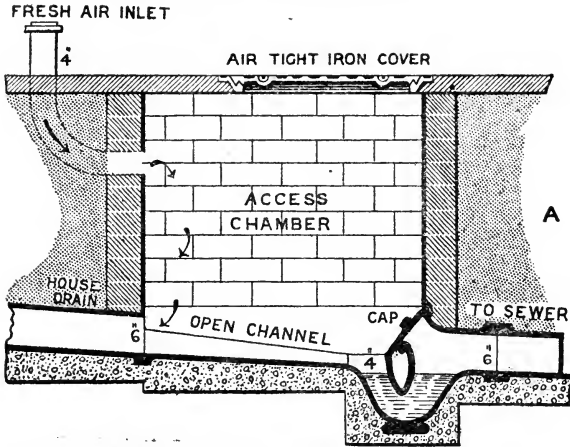

FIG. 64.—Manhole intercepting chamber, with fresh-air inlet.

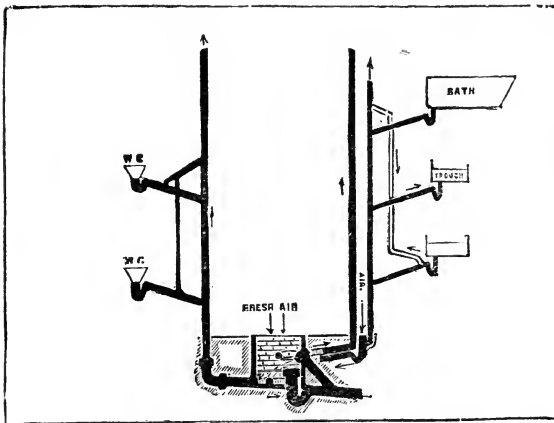

FIG. 65.—Section showing arrangement of manhole chamber, intercepting trap, fresh-air inlet, vent-shafts, soil-pipes, bath and trough pipes, and vent-pipes.

float up into the eye, and there decompose dangerously. Frequently the drain runs so deep down at the outgo in area that no trap can be reached. A manhole chamber then

becomes a necessity, as it is at all times the best and only satisfactory arrangement. It should be in the open air, about 3 feet  $\times$  2 feet, or any convenient size regulated by circumstances; the walls, built of  $4\frac{1}{2}$ -inch or 9-inch brickwork, may be cemented inside, or merely pointed in the joints. The manhole chambers near a dwelling-house should be rendered as staunch, and hold water as securely, as the drain itself. The house drain enters the house side on the bottom, so that, by stooping down, you can look right

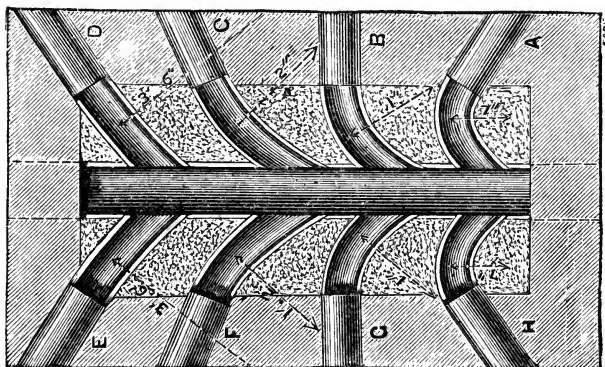

FIG. 66.—Plan of manhole chamber, showing eight separate branch drains joining main drain at various angles.

through the drain to a corresponding manhole in backyard. You should see that it is smooth and level and clean throughout, and you can put a brush or scraper right through for cleansing purposes. It is much the best plan, if you have any other branch pipes or drains inside the house, to lead them also straight into the front or back manhole, so that you can also look through and cleanse them. It is not well to join these drains, or to make any connection into the house drain, as it passes from the back to the front manholes; it should come through intact, if possible. From the main house drain, across the bottom of the manhole chamber, a

groove or channel (half a drain-pipe cut through longitudinally will do, if you have nothing better) should be laid in cement to the back of interceptor trap set at opposite side of chamber in connection with main branch to sewer.

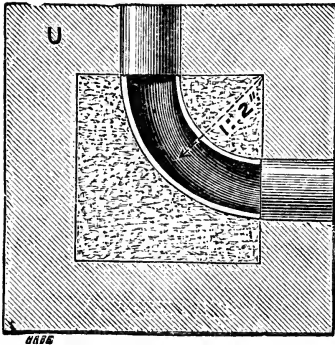

FIG. 67.—Manhole chamber; short right-angle bend, 14-inch radius on centre line.

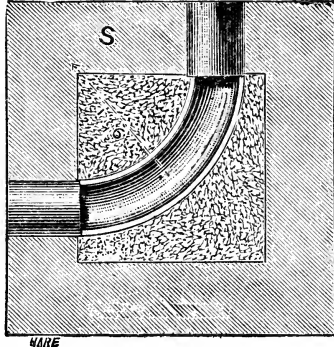

FIG. 68.—Manhole chamber; long right-angle bend, 18-inch radius on centre line.

The bottoms of these chambers should be sloped in cement, to prevent deposit of any foul matters.

These may all be made into intercepting chambers by using any suitable interceptor trap at the outgo end.

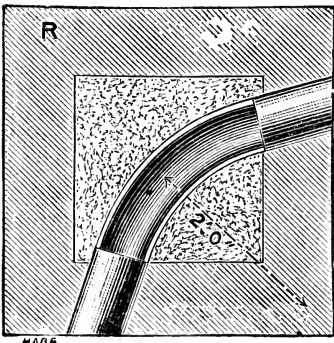

FIG. 69.—Manhole chamber; short obtuse-angle bend, 24-inch radius on centre line.

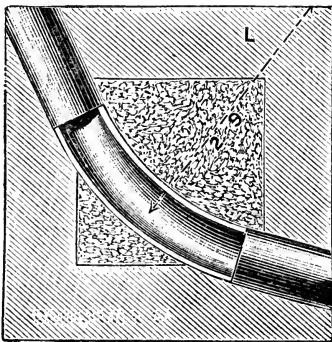

FIG. 70.—Manhole chamber; long obtuse-angle bend, 33-inch radius on centre line.

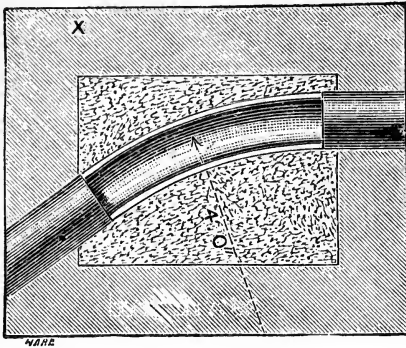

FIG. 71.—Manhole chamber; long curve, 48-inch radius on centre line.

Interceptors should be partly in the chamber, and so arranged as to be seen and cleaned with ease. A splay junction pipe should be carried back from the drain beyond the interceptor into the wall of the chamber, through which the outer drain could be cleared, in event of

stoppage, without pulling up the drain. This cleaning pipe must, of course, be closed air-tight, for, if left open, sewer air would pass into house drain. It would be better and safer to end it outside the chamber in the open air, so that no accident from neglect should be possible. Other branch drains from house and area may be delivered into manhole just above the level of the groove or channel, but so arranged that no flooding back of other drains can occur, all water, etc., passing easily and directly into the interceptor and away, and so that no deposit whatever can remain. The bottom of the chamber, up to the sides of the channels, to be smoothly cemented, with a quick slope towards the main channel. The interior of such chambers should always present, when inspected, a smooth and perfectly clean and pure appearance.

The ventilation of the manhole chambers is all-important. It is always essential to secure thorough disconnection of the bath and trough wastes, overflows, and rain-pipes from the house drain, although it may be perfectly constructed. Some authorities advise the disconnection of the soil-pipes of water-closets and slop-sinks also. It is certainly necessary in some positions, but generally the main soil-pipe will

act better and be safer as a main outlet or inlet ventilating shaft in direct connection with the private drain.

The intercepting trap here shown was designed to provide a means for emptying the manhole chamber through the raking eye arrangement in event of a stoppage occurring in the trap and backing up the drainage. A chain is attached to the air-tight stopper of the eye, which on being pulled releases the stopper and opens direct communication to outer drain to clear the flooded manhole chamber.

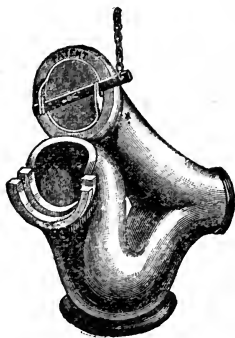

FIG. 72.—Intercepting trap.

In some positions it is extremely important to use a perfectly air-tight manhole chamber cover. In Fig. 73 the

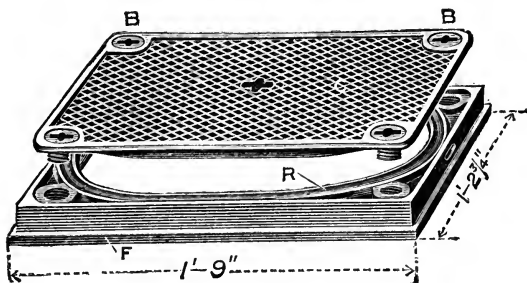

FIG. 73.—Reliable screw-down cover.

coverplate is screwed down to the frame by gun-metal bolts (B) outside a rubber ring (R), which renders the cover reliably secure and gas-tight.

In Fig. 74 the inner cover is arched with the object of condensing any moisture from the drain-air, the water running down into the groove in which the cover sits, thus maintaining a constant water seal. The top cover is flat and fits into another groove, which may be independently

staunched with suitable material. Traffic over the top cover thus cannot affect the inner cover or its water seal.

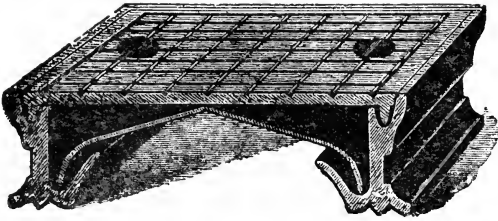

FIG. 74.—Automatic seal air-tight cover.

The extraordinary variety of interceptor traps renders the illustration of all patterns impracticable. We select some of the best forms. In Fig. 75 we have a 6-inch interceptor

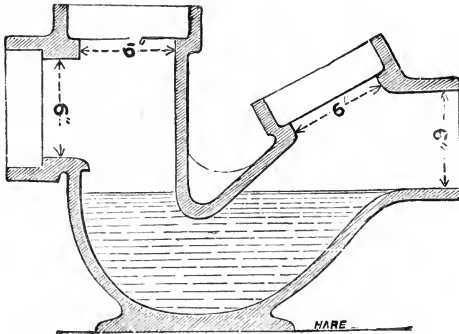

FIG. 75.—Interceptor trap.

with 6-inch inlet and outlet for drainage, 6-inch inlet for fresh air, and 6-inch inspection opening on the outgo to outfall drain.

The drainage falls with cascade action on the water-seal, and there is added a small lip for the purpose of throwing the drainage clear of the back; but, instead of an improvement, this and all unnecessary inner projections are liable to cause obstruction, and are objectionable. A 6-inch trap is generally too large for ordinary dwelling-houses. We have



drawn (Fig. 76), on a smaller scale, a 4-inch interceptor, which is a better size and less likely to choke up, because every water flush thoroughly scours it. Notice the slope given to the top for the purpose of affording easy access for fresh air inwards.

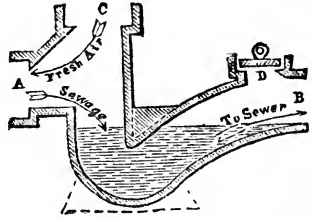

FIG. 76.—Interceptor trap.

Fig. 77 illustrates another form very useful in practice when we want to connect a 4-inch house drain with a 6-inch outfall drain. The trap itself and its inlets

are four inches in diameter, the best size for ordinary dwellings; while the outgo is six inches, thus saving the need for a reducing-piece connection with the 6-inch drain. The

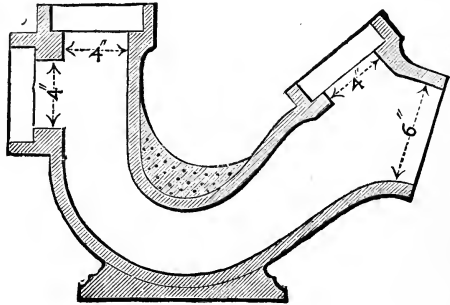

FIG. 77.—Interceptor trap.

level stand or pedestal under these interceptors enables them to be easily set level and true.

The interceptor (Fig. 78) is provided with an extra large fresh-air inlet, and has a sloping back, over which drainage glides into the trap. It is very easily inspected and cleaned, but in cold positions exposes

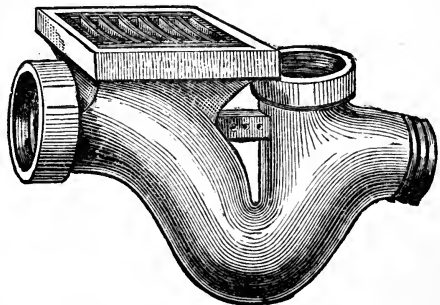

FIG. 78.—Interceptor trap.

the water-seal more than necessary to danger of freezing in winter.

The interceptor (Fig. 79) is a type of an arrangement

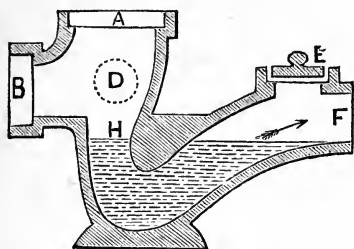

FIG. 79.—Interceptor trap.

which serves well for small house drains: the drainage inlet, B, with cascade action; the air inlet, A, with curved approach to drain; the small water surface at H; and the outgo, F, with its inspection opening and cover. The side connections,

D, may be used right and left to receive branch drains, if necessary.

We have in Fig. 80 an interceptor differing from the

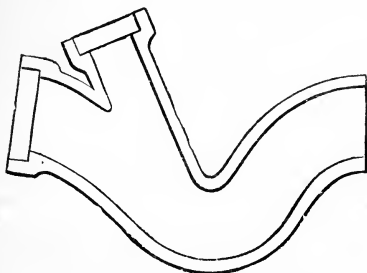

FIG. 80.—Interceptor trap.

former ones in the sloping inlet for drainage and the sloping cleaning and inspection pipe, allowing easy access for cleansing the trap. This is a good form, though the water surface is large. The fresh-air inlet must be

attached further back by a tee-piece on the drain, thus preventing any risk of water-seal freezing in winter.

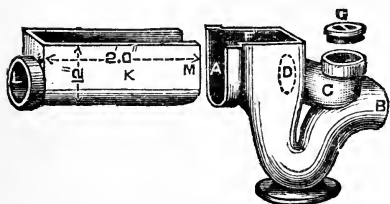

FIG. 81.—Chamber channel and interceptor.

This arrangement of interceptor (Fig. 81), combined with open channel, is an excellent one. It may be used at bottom of a manhole chamber or independently, but

always in an area or other open-air space.

It is a specially suitable arrangement for the complete disconnection of subsoil drains as recommended, the channel being left open or covered by a very open grating. When used for subsoil-drain disconnection, care must be taken to prevent any slops or other sullage waters passing into the open channel.

A recently improved intercepting trap (Fig. 82) contains an enlarged fresh-air inlet and inspection socket, and a well-formed water-seal. The outgo is fitted with a socket, which may be used for ventilation or as an inspection opening.

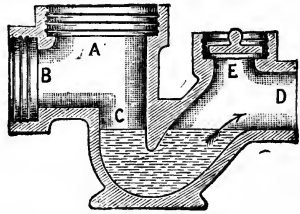

FIG. 82.—Improved interceptor trap.

The success attending the use of the enlarged access and fresh-air inlet intercepting trap led to the demand and supply of the various modifications shown herewith. The illustrations on p. 176 explain the purpose of each form.

For use in manhole intercepting chambers improved interceptors of an excellent form are made with a half socket, taking the open channel at bottom of chamber, and with raking arrangement well placed, to give access to the outfall drain in event of stoppage, as shown in Fig. 64. Great care must be taken to cement securely the stopper of the raking pipe, lest any sewer gas might get back into manhole chamber, and from thence pass into the house drain.

Interceptors are sometimes required in the form illustrated on p. 177 (Figs. 89 and 90), with movable reversible inlet junction tops, which are set to any angle for the drains. Otherwise this form resembles the ordinary interceptor. The movable top must be carefully cemented into the socket of the trap when the desired angle of entry has been determined.

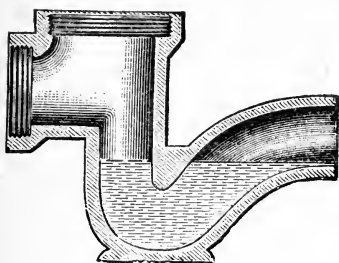

FIG. 83.—Intercepting trap.

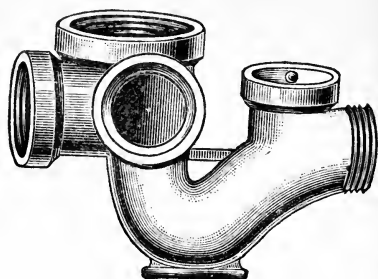

FIG. 84.—Treble junction trap.

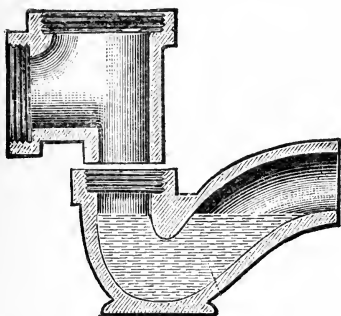

FIG. 85.—Adjustable interceptor.

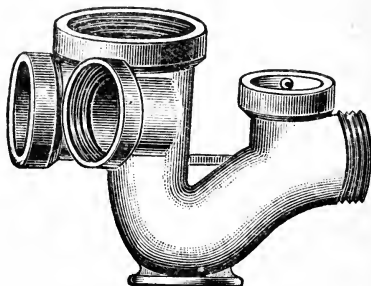

FIG. 86.—Double junction trap.

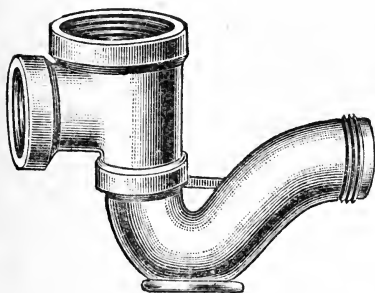

FIG. 87.—Adjustable interceptor.

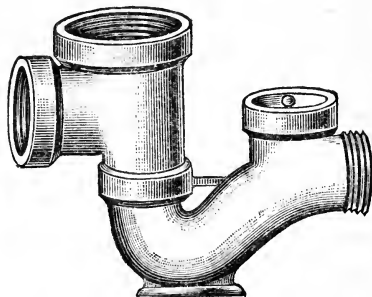

FIG. 88.—Adjustable interceptor.

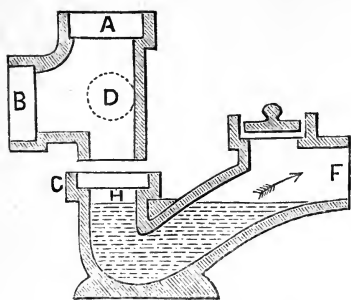

FIG. 89.—Adjustable interceptors.

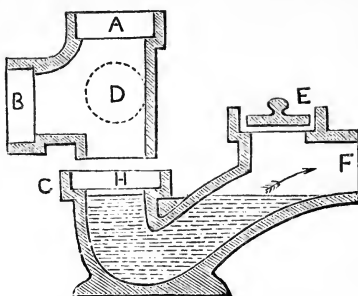

FIG. 90.—Adjustable interceptors.

Disconnectors for bath and trough wastes may be of smaller dimensions than interceptors (Figs. 92 and 93).

We give several arrangements here, in section, which are in very general use, and serve their purpose admirably.

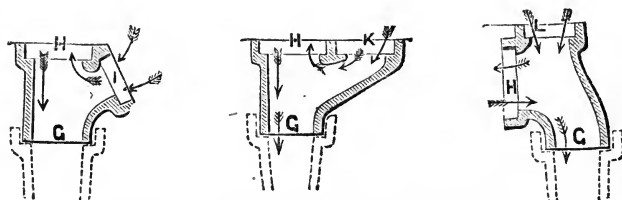

FIG. 91.—Adjustable tops for disconnectors.

The bath waste-pipe usually brings down a volume of water with great velocity from a considerable height, and it may accordingly be utilised to flush the drain, but must on no account be connected direct into it. Neither can it be allowed to discharge over the surface of any grating or trap, so as to cause flooding or slopping of the yard. Basin wastes may be arranged to deliver wherever the bath waste flows.

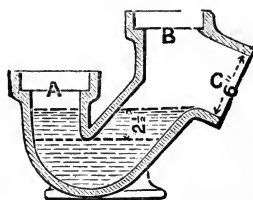

FIG. 92.—Adjustable disconnector.

There are now in the market many forms of suitable bath and basin waste safety receivers, not holding much water, with a wide open grating above the water, and an inlet close up under the grating to receive the waste. There may be two or three inlets also for other clean water waste-pipes. If the waste-pipe is left open above, as it should be, with a full bore ventilating branch, a current of air will flow continually through when the water is not flowing, and so will prevent any accumulation of tainted air.

The simplest form for these disconnectors is really the best. One has no need to incur the cost of patented appliances as a rule. Any potter will make any simple pattern you determine on adopting; but let the iron gratings be very wide open, for free admission of air, and let them be galvanised. Earthenware gratings with holes, still so commonly adopted, are useless for ventilation. Pantry troughs, dairy troughs, laundry troughs, and traps with gratings in floors, all need most careful disconnection from drains, with due precautions to prevent the gratings over the disconnectors becoming choked by dirt or leaves in course

of time. If the entrance of air becomes restricted there is no longer any disconnection of the waste from the drain.

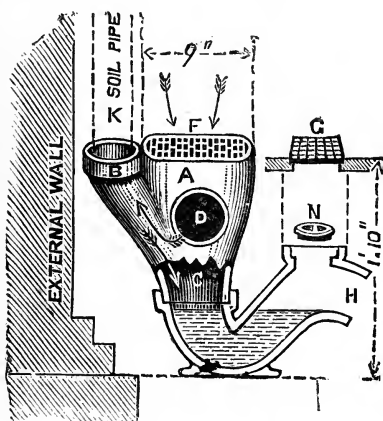

FIG. 93.—Waste-pipe disconnecting trap or receiver.

The vitrified stone-ware disconnecting trap (Fig. 93) is a good form for the base of soil pipes and bath wastes. The pipe receiver at back may be arranged in any required direction, vertical, diagonal,

or horizontal. The large grating as effectually disconnects the pipe from the drain as if it discharged over the surface of the ground.

The disconnecting receiver (Fig. 94) is of simple form, with trap and grating cutting off connection of waste-pipes from drain.

The stoneware base attached to this trap affords secure foundation and enables the trap to be set truly level. Many hundreds of these traps are fixed and have been at work for many years with successful results.

The disconnecting receiver (Fig. 95) is similar to former one, but is arranged to receive a vertical down pipe at back, and one or two horizontal waste-pipes at the sides. This method of disconnection enables the plumber to gather several

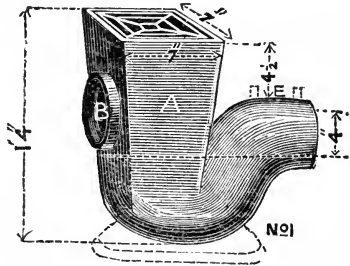

FIG. 94.—Disconnecting receiver.

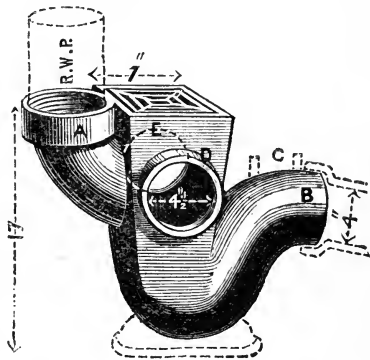

FIG. 95.—Disconnecting receiver.

plumber to gather several

branch pipes to one trap and secures extra flushing to keep the trap clear.

The appliance (Fig. 96) is useful at the foot of metal rain-pipes, giving access to the bend for cleaning and ventilating at same time. Of course it should discharge into a

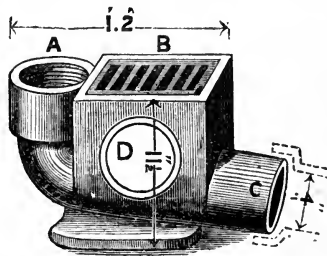

FIG. 96.—Access-pipe connection.

clean-water interceptor, never direct into a foul drain. It is an excellent arrangement at foot of a vent-pipe, giving access for cleaning and inspection, with a close cover in place of an open grating.

The gully-trap construction (Fig. 97) is used for surface

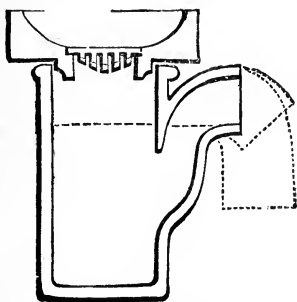

FIG. 97.—Gully-trap.

waters or where rain-pipes discharge overground. It has an enlarged receptacle, in which gravel and sand, etc., from the surface of ground, is retained so as to be removed by hand to avoid choking drains or traps.

The interception of grease from house drains is one of the sanitarian's greatest troubles. In

some mansions the writer has found the accumulation so rapid that the grease-traps filled almost daily with grease,

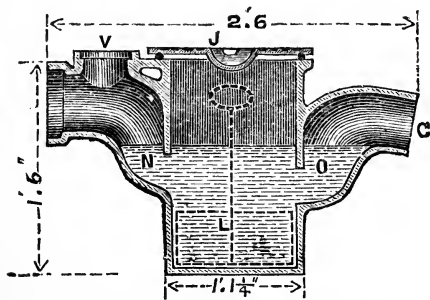

FIG. 98.—Earthenware scullery grease-interceptor, with galvanised-iron cover and lifter.

while in others the traps required to be emptied only once a month. Much depends on the temperature of the water employed in the washing-up troughs and in the management of servants. In many instances it will be

found best to allow the scullery grease to pass away at once to the drain; but in such cases ample access should be provided to clean out the drain with ease. The removal of the grease creates such a nuisance that it is a great advantage to get it passed off directly. Wherever circumstances arise requiring scullery grease-traps, one



or other of the types here illustrated will be found suitable.

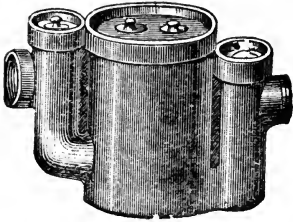

FIG. 99.—Grease-trap.

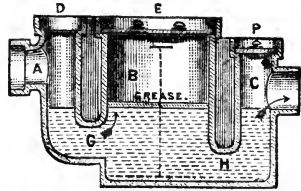

FIG. 100.—Section of grease-trap.

The illustrations explain the construction of each clearly. The principle adopted is to discharge the grease under water,

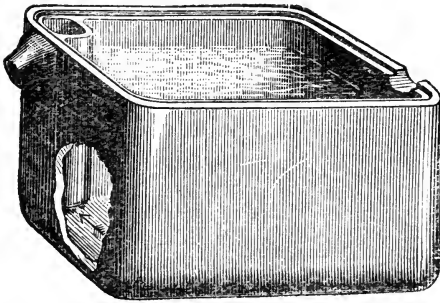

FIG. 101.—Large earthenware grease-trap.

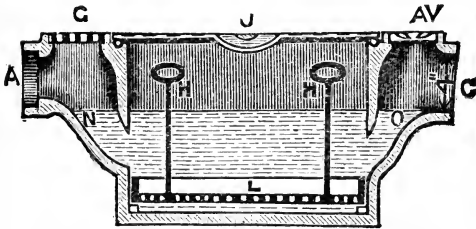

FIG. 102.—Earthenware grease-trap, with galvanised-iron cover and lifting tray.

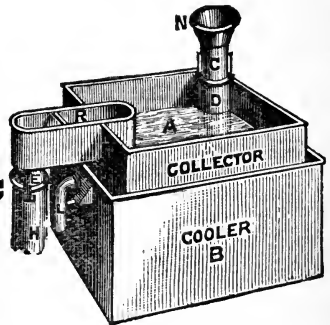

FIG. 103.—Tinned-copper grease-collector for placing under scullery sink for daily removal.

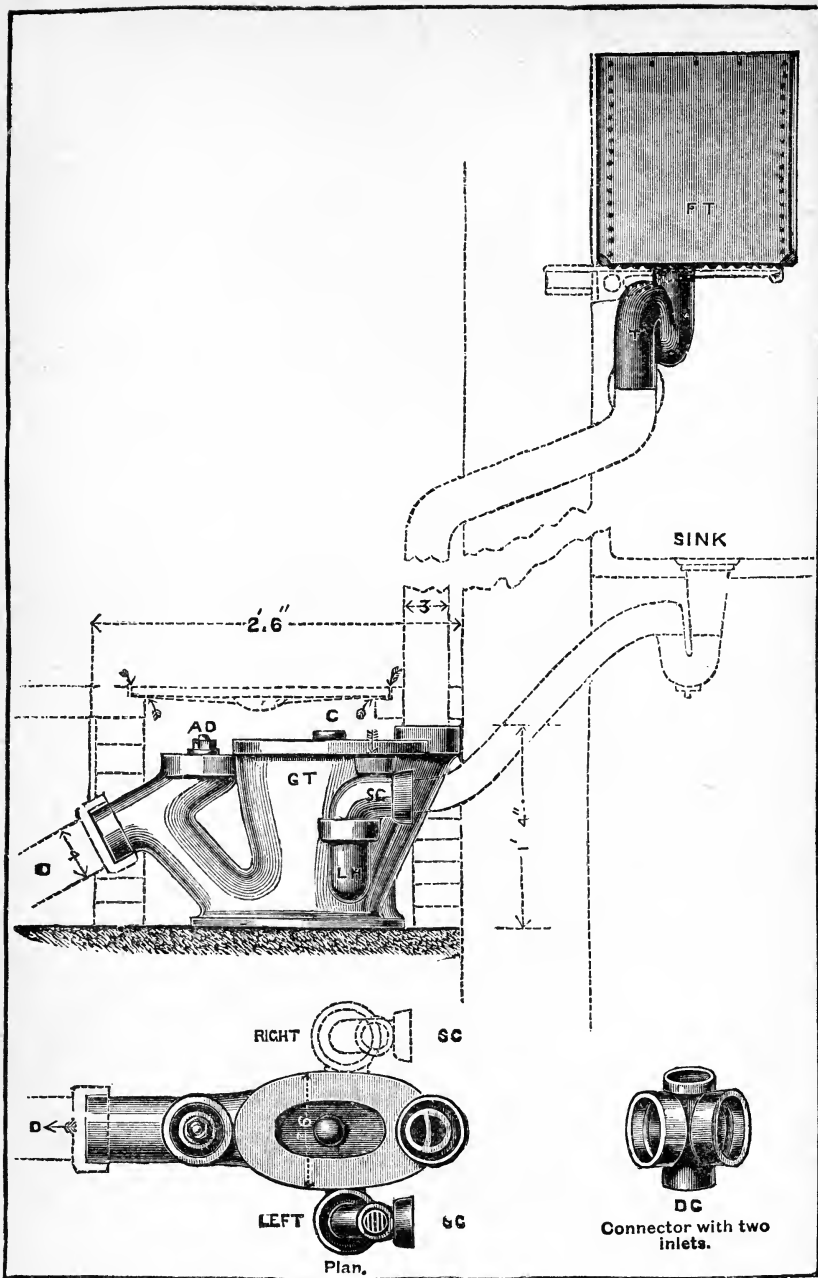

FIG. 104.—Patented arrangement for disposal of scullery grease.

allowing it to cool and rise to the surface for removal, while the water passes away to the drain underneath. Unfortunately, it always happens that even through the best grease-interceptors a large proportion of the grease passes away into the drains, where it congeals and remains, unless ample cleansing provision has been carefully made, and is regularly taken proper advantage of.

As sewers are allowed to receive the greasy water discharges from kitchen and scullery sinks, the "Flush-out" grease-trap, G T, is specially constructed for congealing the grease and sending it to the sewer in the way least likely to foul the sides of the drain.

The trap is made of strong vitrified stoneware, and is provided with single or double inlet connectors on either or both sides, for receiving the waste-pipe or waste-pipes from one or more sinks. The connectors, being movable, can be turned round to suit the direction of the waste-pipes, and a grating is provided for placing over each connector, for disconnecting the sink waste (*i.e.* for opening up the discharging end of the waste-pipe to the atmosphere). Just enough water is retained in the trap to congeal the grease, and the flush from the automatic flushing tank, F T, enters the trap at the back, a portion of the flush passing through a flushing rim, with a jet opposite the outlet, for breaking up the congealed head into small pieces and floating them through the drain, the remainder of the flush being conducted downwards by a separate water-way to the bottom of the trap for scouring out solid matter.

The trap may be fixed in a brick manhole chamber with a galvanised-iron cover let loosely into a stone cover over same, so that air can pass into the chamber, or where out of the way of traffic the trap may be fixed with its earthenware cover at the surface level.

The flushing tank, F T, for discharging about 20 gallons of water, may be fixed anywhere within 20 or 30 feet of the trap, so long as it is kept on a higher level for the flush to pass into the trap with a good cleansing force. If there is a fall of from four to seven feet the flushing pipe, F P, may be of 3-in. bore, but if the fall is less the bore of the pipe should be 4-in. The flushing tank should be made to discharge once in every twenty-four hours, or at shorter or longer intervals to suit the requirements.

The ventilation of the house drain and branches and manhole chambers must be thorough and constant. The best method is to carry a 4-inch cast-iron or, better still, lead vent pipe or shaft from the drain or manhole chamber in front area, direct and straight as possible, up the front of the house to the roof. Here it may stand up straight, surmounted by an ornamental extractor top, or it may be surmounted by a mock rain-water hopper head, if there be a parapet, a bend being turned in at the back of the hopper and continued, as a pipe of same bore as vent-shaft, along the slope of roof to the ridge, where the vent-shaft may end vertically just an inch or two over the ridge, or with an extractor top. The sweep of the wind up the roof from either side will act effectually as a natural exhaust, and create a suction in the vent-shaft which is very serviceable. If the vent-pipe be of heavy lead it may be carried up under the roof, and out through the ridge.

There is no use whatever in providing an outlet vent-shaft on any drain unless you also provide a corresponding inlet through which some colder, and therefore heavier, column of air may press in and drive the lighter air in the vent-pipe upward. If you take a water-pipe from the

top of a boiler into a cistern on a higher level, and warm the water, it will remain nearly dead in the pipe, only expanding a little as it slowly heats by convection; but if you carry a return-pipe down from the cistern to the bottom of the boiler the cold water in it will force up by its greater weight the lighter warm water, and the circulation of water is complete. The same result takes place with air in vent-pipes. We must therefore provide a fresh-air inlet in addition to the outlet.

If you open a hole in the bottom of the open top vent-pipe, or in the manhole chamber connected directly with it in front area, you have ventilation at once. The air flows in and up the vent-shaft. However, it is not the vent-shaft we want to ventilate, but the house drain and the soil-pipe; consequently, if we go to the upper end of the soil-pipe in the rear of the house and open an inlet there, we shall probably find the air flowing in down the soil-pipe along the drain, through the manhole chambers, and up the main vent-shaft, a constant current day and night, and every time that water is sent down the soil-pipe the ventilating current of air is accelerated on its beneficial course.

Now, whether the air will take the course indicated, or whether it stays still, or whether it annoys us by coming back the opposite way, depends (if we leave out of consideration the sucking action of the extractor top on the vent-shaft) on the relative condition of the column of air in the vent-pipe at the front of the house, and in the soil-pipe at the back of the house. If both pipes are of equal height, then the air, being warmest on the sunny side of house, will have expanded and become lighter, and so surely as the heavy side of the balance weighs down to earth and sends up the lighter scale, so surely, and on the same principle precisely (the universal attraction of gravity), will the heavier column of air send up the lighter column. It will be well,

therefore, to arrange your inlet pipe as low as possible and in the coldest position, shaded from sunshine, and your outlet extractor vent-shaft as high as possible, free from all blow-

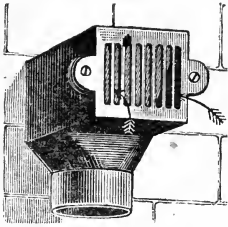

FIG. 105.—Single mica flap-valve for vertical air inlet.

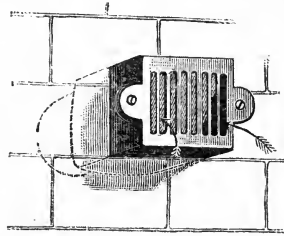

FIG. 106.—Single mica flap-valve for horizontal air inlet.

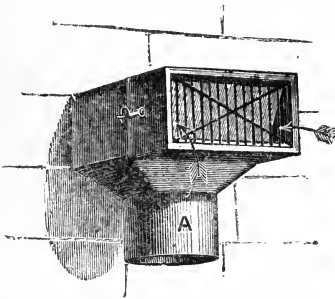

FIG. 107.—Double mica flap-valve for vertical air inlet.

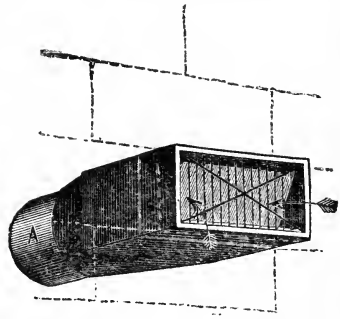

FIG. 108.—Double mica flap-valve for horizontal air inlet.

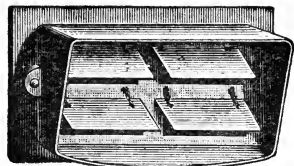
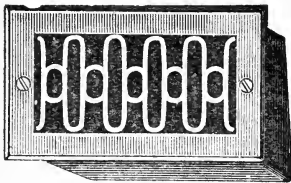

FIG. 109.—Ornamental quadruple mica flap-valve, showing also back view and construction of the mica valves, hung on copper loops, and moving with the slightest breath of air to open or close.

down action of wind, and in as warm a corner as you can find for it, avoiding all needless bends.

The position of air outlet or inlet cannot be definitely

settled here, but must be varied to suit the various construction of buildings. The plumber, by keeping in mind the cause of the movement of air, can hardly fail to place his vent-pipes and inlets so as to give the desired ventilation.

The inlet fresh-air opening must in some cases be provided in an enclosed yard or area, and occasionally these areas have windows or doors opening on them, through which any back puff of odorous air happening to come from the inlet caused by a reversed current, might be drawn into the house. Endeavour, in the first instance, to find a better position for your inlet; but if you fail there, two courses are open to you. One of these is to place one of the mica flap-valves here illustrated on the inlet mouth. If you take care that the opening of the inlet is not reduced in area no injury is done to the inlet, and the same volume of air will enter as if no valve was employed; and in case of back puff or draught the mica flaps instantly close by the action of the air upon them, and no inconvenience is caused.

Some of the cowls employed in practice are very complicated. All revolving cowls require constant attention, and as they are usually fixed high out of reach on top of a roof, that necessary attention and lubricating involves the double risk of injury to slates and gutters and of breaking the workman's neck. If they are neglected they become fixed, and stop or reverse the draught, instead of helping it upward. Take any revolving or Archimedean cowl or extractor, and watch how slowly and feebly the inner Archimedean screw revolves in any ordinary breeze, and judge how little effect it can have upon the air in the tube.

Do not allow yourselves to be deceived into the belief that any particular form of extractor is powerful from the

toy experiments with a little model fixed on a glass tube generally produced by touters for orders, because the force of the breath as applied in these experiments is out of all proportion to the force of wind upon a cowl in action, and you can produce the effect of causing the morsel of light cotton wool generally provided to rise in these glass tubes if you remove the model extractor top altogether and blow across the end of the glass tube. In many instances the effect is more marked with the plain open tube.

These illustrations (Figs. 110-112) show three forms of useful soil-pipe extractors formed on common-sense principles. The three shown without any top, having a light

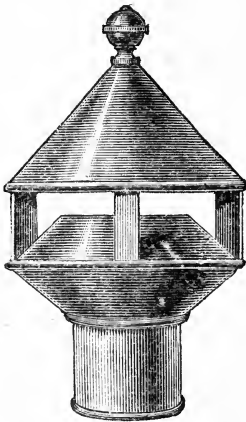

FIG. 110.—Covered extractor.



FIG. 111.—Covered extractor.

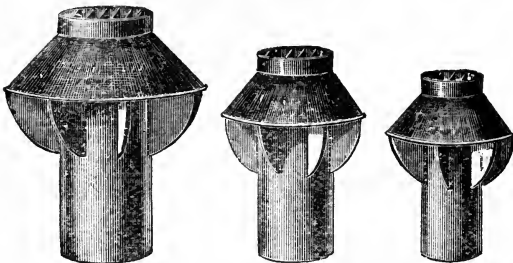

FIG. 112.—Open top extractors.



series of thin wires across to exclude birds, illustrate the best form of extractor for soil-pipes, in the writer's opinion; it was designed by him, as he could see no reason for obstructing the upward movement of the column of air by placing a cover across it—a plain open pipe will act better. In addition to the unobstructed tube, however, we have here a series of chambers which catch whatever breeze is passing, and send it in accelerated force through a narrow slit across the top of the tube, causing a vacuum, and consequently an upward current. One kind of extractor may draw stronger in a high wind; another may obstruct less in a calm; but, as a rule, it will be found that an open pipe with a simple arrangement such as this for deflecting the passing wind upwards, without obstructing the ascent of the column of air in heavy weather and calm, will be all that a plumber need recommend, fixing the extractor well above surrounding objects, free from chance of a return blow-down.

Cowls made trumpet-shape, turning with the wind, and depending on the vacuum which can only be produced in strong wind for the upcast extraction, are as irregular and uncertain in action as the wind itself, and they all eventually become neglected, and then soon stick fast, and are worse than useless.

In some houses the inlet and outlet pipes at back and front are carried up above the roof, and are fitted at top on same level with trumpet-shaped mouths pointing north and south or east and west respectively—depending on the direction of the wind, the outlet sometimes becomes the inlet, the upcast becomes the downcast. The fault in construction lies in three points: (1) a high wind may directly unsyphon the closet traps; (2) a frosty air blowing down

may freeze the pipe if water is passing; (3) if the wind be blowing equally *across* both mouths, or if it be calm, stagnation results and danger arises.

#### THE METHOD OF TESTING HOUSE PIPES AND DRAINS.

Long experience is absolutely necessary to give the skill essential for the thorough inspection and testing of drains and sanitary arrangements. Although the author has inspected more than 3,500 houses, he yet finds fresh difficulties to surmount, and new combinations of faults to detect and remedy.

When called to examine the sanitary fittings of a house, first ascertain whether any illness has occurred which may be attributed to defective fittings. If typhoid, then look specially for water pollution and dairy or larder drain defects. If diphtheria or bad sore throat, look for the leakages in drains or pipes of foul air, or entrance of foul air near rooms where illness took place, but be always alert to note everything, as the origin of diphtheria infection is still obscure. Proceed to the roof and take note of the rain down pipes, and of any vent-pipes or the absence of them; then go rapidly through the rooms, floor after floor, noting in your mind the kind of fittings and their position, remembering them as well as you can. Finish at the basement and front and back areas.

Now make an accurate plan of the basement to, say, one-quarter or one-eighth inch scale in your book. This is the most important part of any sanitary inspection or test. Without a plan you cannot bear in mind the position or arrangement of drains or fittings for one week, especially if you have two or three houses to inspect daily. That done, proceed to test the drains. Make an opening at the rear of drain, and cut across the drain in front; close it watertight

with one of the indiarubber bags used by gas companies, as shown in Fig. 113,

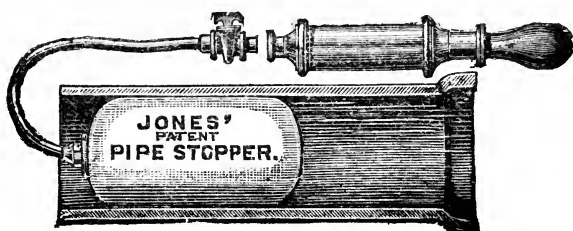

FIG. 113.

or, better still, with an expanding drain stopper in which indiarubber ring is expanded by screw pressure.

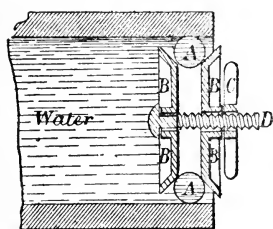

FIG. 114.—Drain plug or stopper for use in testing drains and pipes during hydraulic and smoke tests.

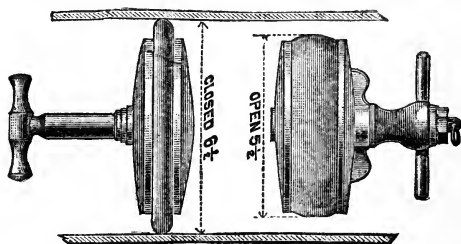
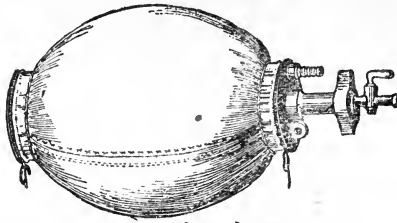

FIG. 115.—Jones' Patent Expanding Screw Stopper.

These stoppers are made in brass and iron to suit drains from 4 in. to 24 in. diameter; they are easily applied and are most effectual. Be careful to fix the drain stopper in such a position that you can easily see that it keeps staunch during the period of your test.

You then proceed to the rear of the building and fill the drain with water.

You must, of course, stop up any low-level openings, to prevent escape of water. Watch the water-level in rear,



STOPPER INFLATED.

FIG. 115.—Drain stopper.

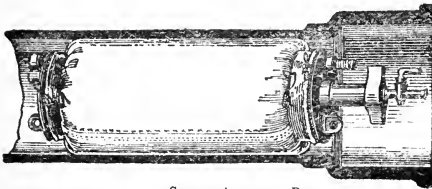

STOPPER APPLIED TO DRAIN.

FIG. 116.—Drain stopper.



6" LOOSE CANVAS COVER

FIG. 117.—Drain stopper.



FIG. 118.—Drain stopper.



4" LOOSE CANVAS COVER

FIG. 119.—Drain stopper.

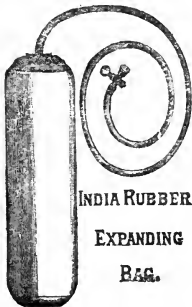

FIG. 120.—Drain stopper.



FIG. 121.—Drain stopper air pump.



BRASS AIR PUMP

FIG. 122.

and if it does not sink the drain is staunch ; if it does sink, endeavour to discover where it is escaping, and see whether any is running away along the outside of the drain and appearing where drain is open in front. Carefully distinguish between the water escaping from the drain, leaking round the bag, and the water escaping from joints of drain behind and escaping outside the drain. Having noted all this, and the time water stood in the drain, fill it up as full as possible and suddenly withdraw the bag, and watch the speed of the water flowing out, and note what amount of filth or deposit is carried away by the rush, to determine whether the drain held the soil in deposit or not. To enable you to tell approximately how many gallons of water should fill any drain, note that a 4-inch drain contains half a gallon, a 6-inch drain contains one and a quarter gallon, and a 9-inch drain contains two gallons and three-quarters per lineal foot. Therefore a 6-inch drain, fifty feet long, will take about sixty-two gallons to fill it, while a 9-inch drain, same length, will take one hundred and thirty-seven gallons to fill it. Note the velocity of flow through the drain, and thus ascertain the gradient.

Proceed now to test the soil-pipes and connections by the smoke test. Take any apparatus that will blow smoke into the drain, and, using brown-paper or oiled tow fuel, or the specially prepared smoke-rocket, force the smoke into the drain, shutting all doors and windows at front of house when you apply the test at the same place where you have already cut the drain.

There is one smoke-producing and forcing arrangement with a revolving blower like Clark's bellows, another with a pumping bellows action, and yet another plan of testing by a squib or rocket, which burns for five to ten minutes in the drain. All the connections, traps, and joints should be carefully watched through house, and smoke escapes noted down.

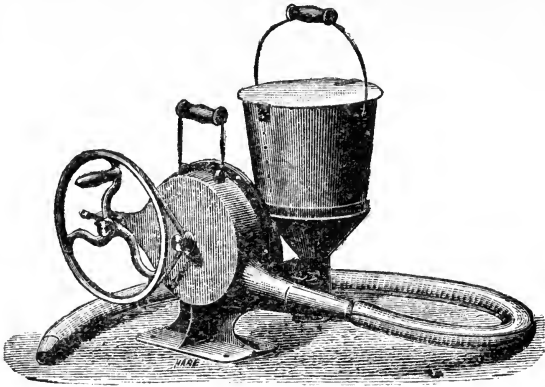

FIG. 123.—The asphyxiator, for applying smoke test to drains.

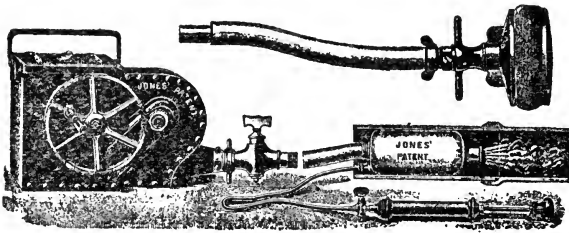

FIG. 124.—Smoke generator for testing drains.

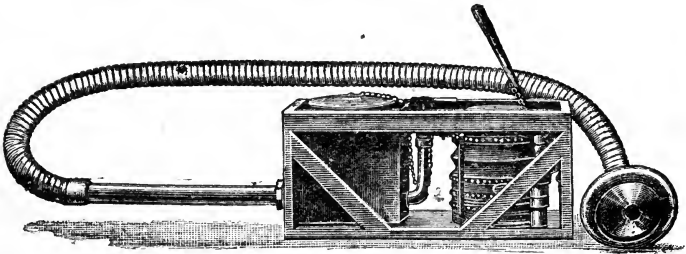

FIG. 125.—Smoke generator for testing drains.

The peppermint test is applied by taking a small bottle of oil of peppermint and a can of boiling water out on the roof and pouring them down the vent-shaft of soil-pipe if you can get at it, closing the vent, and having someone

in the house to note if any smell of peppermint becomes apparent, and where it comes from. The test requires delicate handling and is troublesome; the person applying it will have to remain some time on the roof, for if he comes into the house he brings the odour of peppermint with him, which spoils the test. The hydraulic and smoke tests will be sufficient as a rule.

The sulphur test is powerful and searching. Take one pound of flour of sulphur, and pour half an ounce of methylated spirits over it; set it in an iron plate in the drain, set it on fire, and cover it up, and the fumes will show any defects in the house very plainly; but the house should be empty, as these fumes escaping are very irritating.

Proceed to examine the surface traps, troughs, sinks, closets, cisterns, and their overflows; specify in your notes the arrangements of each in detail for waste-pipes, overflow, trapping, and state where water supply is drawn from. Fill each with water, and discharge again to see if waste is clear, if trap unseals, or if any other traps are affected in the other appliances by the discharge. Note the rain-pipe

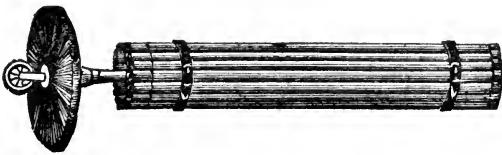

FIG. 126.—Drain-cleansing machine.



FIG. 127.—Drain-cleansing rods.

connections and air-vent pipes, and their terminals above and below. If necessary, pass drain-cleansing machine

through drains and branches, and observe condition of interior thus revealed.

Note the waste-pipes from safe-trays, and see if they discharge safely in open air.

In fact, note everything up and down, that can possibly affect the sanitary condition of the house and the health of the residents, and remember, when you are asked to inspect and give your opinion as practical men on the sanitary condition of a dwelling-house, that a great and



FIG. 128.—Double spiral screw to extract cloths, etc.



FIG. 129.—Archimedean screw to clear drains.

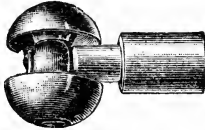

FIG. 130.—Duplex roller. Prevents ends of canes catching, and turns round bends.

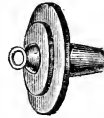

FIG. 131.—Drain plunger, with brass cup and screw.

solemn trust and responsibility is laid upon you, and that the lives of the future residents may depend upon the care, skill, and thoroughness which you devote to the execution of your duty, and that one careful and thoroughly practical report will show that you know your business and are willing to do it well, and will do more to prove that you are practical men, and proper persons to make sanitary inspections of houses, than all the letters written to all the newspapers in the kingdom.

A list of fifty-one specific insanitary and dangerous defects actually discovered during sanitary inspections in dwelling-houses may prove a serviceable indicator.



1. Common brick or stone-built drains under basements.
2. Large, built drains under or near dwellings.
3. Pipe drains of larger diameter than actually necessary.
4. Pipe drains broken, or with leaking joints, saturating the subsoil with sewage.
5. Pipe drains with built or imperfect junctions.
6. Pipe drains under dwelling without sufficient fall.
7. Pipe drains with fall in the wrong direction.
8. Drains of any kind without proper intercepting traps.
9. Drains of any kind without constant free current of air throughout.
10. Drains without easy means of inspection.
11. Drains carried from public sewer direct under hall-door steps and under scullery floor instead of across open area.
12. Rat burrows from built drains undermining floors.
13. Rat burrows from public sewer worked along outside pipe drains into houses.
14. Defective connection between soil-pipes and drain.
15. Soil-pipes inside houses under almost any circumstances.
16. Soil-pipes inside or outside without any or ample ventilation.
17. Soil-pipes through pantries, larders, or stores.
18. Defective, badly placed, or ill-constructed water-closet apparatus and housemaids' slop-sinks.
19. Water-closet cisterns with overflows joined to soil-pipes or drains.
20. Safe-trays under water-closet joined to soil-pipes or drains.
21. Two or more water-closets or sinks on one soil-pipe, untrapping each other when used.
22. Overflow-pipes connected to soil-pipes liable to become untrapped, all very dangerous.

23. Water supplies over troughs taken from water-closet or other contaminated cisterns, and liable to be used by careless servants to fill bedroom carafes for drinking.

24. Taps for supplying bedroom water fixed over housemaids' slop-sinks, liable to be polluted by splash from slops emptying.

25. House cisterns, with overflows, joined to soil-pipes or drain.

26. Traps of every kind, without ample ventilation to guard them.

27. Scullery sinks connected direct to drains, admitting foul air, not only through traps, but through joints of brickwork and plaster all round.

28. Bell traps, with loose covers on scullery sinks.

29. Gullies or traps in floors of sculleries, laundries, larders, or basement, etc., connected to drain, and usually dry and untrapped, or full of foul deposit.

30. Ventilating foul-air shafts, discharging near chimneys, or windows, or ventilating openings.

31. Rain-pipes used as ventilators for drains, discharging foul air near bedroom windows, or under roof eaves.

32. Rain-pipes used as or connected to soil-pipes, likely to freeze soil-pipe solid in severe winter.

33. Rain-pipes passing down centre of houses connected in any way to drains.

34. Open rain courses from valley gutters, passing under floors to outside down pipes connected to drain.

35. Rain-pipes of low roofs, bow windows, or porches connected direct into drain.

36. Ashpits located near larder, pantry, or dwelling.

37. Ashpits liable to let moisture soak into house.

38. Ashpits capable of retaining moisture, or unventilated.

39. Rat burrows from defective drains in neighbouring premises.

40. Defective drainage or fittings in neighbouring premises.

41. Any direct communication with drains of neighbouring premises.

42. Water tanks in areas, near ashpits or sculleries, or with any connection of overflow to drain.

43. Bath waste or overflow pipes connected to soil-pipes or drains.

44. Washhand-basin wastes or overflows connected to soil-pipes or drains.

45. Water-closet cisterns under bedroom or parlour floors.

46. Cesspools near houses, or unventilated anywhere.

47. Cesspools or drains near wells.

48. Drains crossing your house from neighbours' premises.

49. Field or surface-water drains, with open joints, under basement connected to house drains direct.

50. Damp basements or damp walls.

51. Drinking water defects of source, supply, or storage.

The writer found all these defects associated together when lately inspecting a nobleman's mansion in the north of Ireland.

When contractors know their business well enough to be employed to arrange and carry out their own drainage in connection with their own plumbing, it would appear reasonable to believe that all honest men would take such pride in their work, and in maintaining their own character, that the best results for the householder might be expected in employing such competent men and making them responsible under the architect's supervision; and, of course, as a necessary preliminary, by paying such competent contractors well for their time and work, and thus assuring them that their time shall not be wasted in useless and

degrading competition, as we know it to be carried on in the present day.

There is no reason that I know of (except the national epidemic of "the sin of cheapness" at present raging) to prevent the general adoption of some just and honest method of arranging or contracting for plumbing work. For instance, select carefully the master plumber you wish to employ, making due inquiry into his character and experience, and inspecting some of the recent work by which his character was formed and his experience gained. Invite him then to call on your architect, who should explain to him that he is asked to confer and consult as to the plans and specification of the drainage and plumbing of the building in question, to offer his suggestions freely for consideration, and to give a detailed estimate of the prices at which he would undertake the work, on condition that the architect should then examine the estimate, and that if in his opinion the estimate is reasonable, that then, without competition, the work should be entrusted to that master plumber; but that, in the event of the estimate being considered too high, then and there the matter should end, and the architect be at liberty to seek another contractor.

The author has experienced the practical success of this method, and if it or some better plan were universally adopted, we should soon see an end of scamped work. Masters would emulate each other to justify the confidence placed in them. The wretched work produced by men whose estimates have been forced down in competition necessarily under the actual cost of proper work, and the starvation contracts and bankruptcy competitions, would cease to debase the handicraft of plumbing as they are doing now.

Fair profit in business or in handicraft seems often nowadays to be considered and treated by the wealthy as

a sin worthy of disgrace and even punishment, so that such profit is becoming less and less every year; but let us say this word in conclusion: the day that sees fair business profits swept away by competition or by any other means will be the very worst and darkest day that England as a great commercial nation has ever seen.

## CHAPTER VI.

### SANITARY PLUMBING.

PLUMBERS should always arrange for soil-pipes to be fixed outside the outer wall of house, and to be carried up full bore to a point above the roof where blow-down of wind cannot occur, and where the outlet will be as far as possible from skylights, chimneys, or windows.

Soil-pipes must frequently be fixed at the end of return buildings below the level of main building roof. Any attempt to make outlet shafts in such a position will fail, unless air disconnector and inlet be placed at the foot, for the same reason that a stove flue so placed will discharge the smoke into the house rather than up the flue. When the wind blows towards the house from the back these pipes may sometimes draw, but then the foul air or smoke must be driven in at the back windows. In such a position, if a disconnector cannot be attached, the proper plan will be to utilise the soil-pipe of the return water-closet as a downward fresh-air inlet, and to provide the main upward, outward ventilating shaft from the drain in the front to the top of the main house roof.

Opinions differ as to the best size for soil-pipes. A Glasgow authority recommends five inches in diameter, while a London authority maintains that he has proved that three inches in diameter may be used, even though several water-closets are branched thereto. The mean of

these extremes will be about right, for these reasons: 5-inch soil-pipes are not thoroughly cleansed by restricted flushes of water, so that the soil adheres to and dries on the sides, vitiating the internal air. Large soil-pipes are more costly, and, in order to possess equal strength, must be as much heavier as they are larger than 4-inch diameter pipes. They therefore occupy more space, look more clumsy, and are more difficult and costly to fix. Three-inch soil-pipes will really cleanse no better than  $3\frac{1}{2}$ -inch or 4-inch, because these cleanse perfectly with 3-gallon water flushes, and 3-inch pipes are more liable to hold the descending column of water, together acting as a pump piston, driving the air before it and sucking the air behind, creating a vacuum, and tending to unsyphon the traps of the fittings connected with it.

The maintenance of the water-seals of traps is one of the most important duties of a plumber, and should be well considered, so that in some positions, perhaps, 4-inch and even  $4\frac{1}{2}$ -inch soil-pipes might be safer sizes. Generally, however,  $3\frac{1}{2}$ -inch and 4-inch will be found sufficient. The author frequently specifies  $3\frac{1}{2}$ -inch soil-pipes, especially when there is a 4-inch drain to receive them.

Syphonage of traps should always be guarded against by using suitable traps and ventilating the outgo bend of every trap separately and fully. These vent-pipes may be taken direct to the roof level, or be joined into the ventilated soil-pipe *above* the highest intake branch.

The best material for soil-pipes is undoubtedly drawn-lead piping; it possesses the qualities of smoothness of surface, freedom from corrosion, pliability in bending, security in jointing, and the peculiarity that the material remains valuable even when worn out. The weight of lead in soil-pipes should not be less than that of seven pounds to

the square foot, and though eight, nine, and ten pounds would prove better in the long run, such good work is seldom ordered or sanctioned.

Cast iron has also advantages as a material for soil-pipes: it is cheap, which suits the public; it is easy to fix, which suits the second-rate plumber. Rain-water pipes are used for this purpose, but are very much too light; stove-pipes and underground water-pipes are clumsy and ugly; but special heavy-cast soil-pipes answer the purpose in every possible respect. They must have strong sockets, giving ample space for the jointing; they should be tested at the works to a hundred pounds hydraulic pressure for flaws; they are made in lengths from two to six feet; they are to be obtained in any part of the kingdom; and, besides all these advantages, there are branches, junctions, and bends *en suite* of every possible form, and when coated hot in and out at the foundry with Dr. Angus Smith's Preservative Composition, which fills all interstices and gives a smoothness of surface almost equal to lead, nothing is left to be desired for cast-iron soil-pipes.

There is a very excellent method of fixing cast-iron soil-pipes, waste-pipes, and rain water-pipes, which deserves a wide adoption. The pipes and fixings are obtainable in the open market. By means of special forms of clips or brackets, as here shown (Figs. 132 to 138), the pipes are firmly held at a slight distance from the supporting wall, leaving an open space between the pipe and the wall, thus giving access to make secure joints, to paint the pipes from time to time at the back as well as the front, and to prevent dampness, which so frequently passes into the walls when the pipes are laid against them or partly sunk in them.

Even in case of cracked or choked pipes all cause of damp to walls is avoided.

These connections are easily fixed and easily removed;



they have projecting lugs with slotted holes, which lift on over nail heads and clip them firmly.

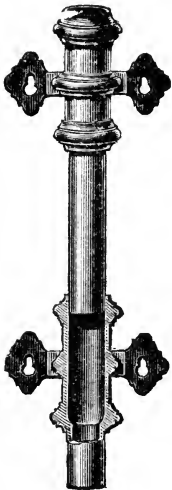

FIG. 132.—Round pipes with 7-inch sliding sockets.

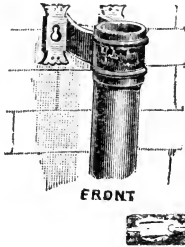

FIG. 133.—Short socket pipes for cottage use, projecting one inch from wall.

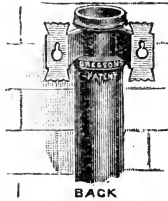
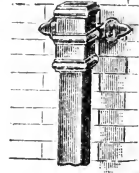

FIG. 134.—Square pipes with sliding sockets.

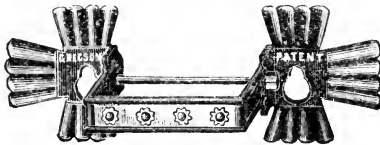

FIG. 135.—Ornamental projecting clips for square pipes.



FIG. 136.—Projecting brackets for eared pipes.



FIG. 137.—Small-sized hanger, for eared pipes.



FIG. 138.—Projecting clips for round pipes.

By lifting any length of the pipes so fixed it will pass over the nail heads and come free without disfiguring the

walls, removing the nails, or disturbing other lengths of pipe.

In jointing lead into iron pipes the joint must never occur in the thickness of the wall; the soil-pipe should be fixed a foot away, sideways, from the branch coming through the wall, and a bend be added to the branch to allow the joint with the iron to be in open air.

While on the subject of joints between lead and iron, let us consider how to make them securely.

If a lead pipe be slipped into the socket of an iron pipe, no reliable joint can be formed; if we try to pack the joint tightly with red or white lead, the soft lead inner pipe must cave inwards and reduce the bore, and the white lead will dry and shrink so as to leave an opening round the joint, whence foul air can escape.

We have here (Fig. 139) a joint soundly made between lead and iron.

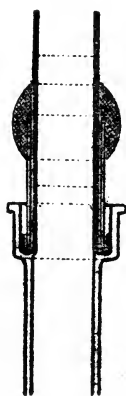
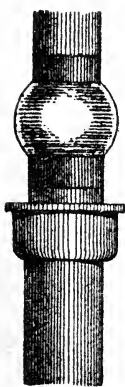

FIG. 139.—Lead and iron pipe joint.

A piece of brass pipe, slightly larger than the lead pipe and six inches long, has the upper end tinned and prepared in usual way for plumber's wiped joint; the brass ferrule is then slipped over the lead pipe, the lead dressed round and up the lower end of ferrule. It is then soldered at upper end of ferrule, and when the inner surface is examined and found smooth the end with brass ferrule is slipped home into the iron socket, packed round with rope-yarn, and molten lead poured in and gently batted home with calking tool and hammer, taking care to leave no hollow in the top of joint for water to lodge in and freeze in winter.

In jointing an iron pipe into an iron socket, gaskin is first packed in round the socket, and molten lead then poured in and well batted home. The socket and pipe should be strong to bear this hammering.

In jointing iron or lead soil-pipes into earthenware drain-pipes at foot, flanges should be affixed to the soil-pipe so as to grip cement firmly, and such joints should be vertical, never horizontal.

The jointing of lead pipes can only be taught at the bench in actual practice; it forms part of the daily routine of a journeyman plumber's work; nevertheless, young plumbers may be able to take a useful hint or two from a brief technical description, such as any master might give to his apprentice, and as the writer has given to his apprentices and improvers for many years.

The true foundation of a good lead joint lies in the careful and skilful previous preparation of the ends of the pipes to be joined. The writer has found great difficulty in convincing young plumbers on this point; they are invariably anxious to produce a good appearance in their joints, and neglect the more important part—that of securing accurately fitted ends and a smooth interior. The interior of all joints—that portion where the water runs—is tenfold more important than the exterior appearance.

Lead joints smooth and shapely on the outside, but rough and jagged within, are hypocritical deceptions, deserving condemnation; they occur through negligence, ignorance, and want of skill.

Whether the joints are made in a vertical or horizontal position, the interior of each joint must be most carefully adjusted and fitted, presenting no edges to the flow of the water, nor jagged points that might catch passing objects, not contracting in any part the area, nor leaving any space

through which the molten solder can find entrance while the joint is being made. Masters cannot be too persistent or too particular in impressing these points on their apprentices and journeymen; they apply to all kinds of lead joints.

Lead slip-joints (*l*) are unworkmanlike in any position; when made inside the walls of a dwelling-house they are extremely dangerous. The writer has discovered, when making sanitary inspections of houses, many hundreds of such joints on solid and waste pipes connected to drains direct. The under pipe is enlarged enough to receive the upper pipe, and the two are then fitted and slipped together,

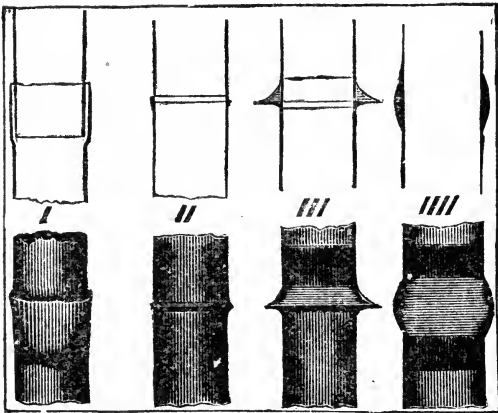

FIG. 140.—Four varieties of lead-pipe joints.

sometimes receiving first a coat of red and white lead; sometimes the joint is left to take care of itself, sometimes it is packed with putty, which generally forces inwards the inner pipe and contracts the waterway, and sometimes, as was the case with a man styling himself a London plumber, whose proceedings the writer watched with wonder in a London dwelling-house, the slip joint, made inside the house on a soil-pipe, is wrapped round with canvas and tied with twine!

Strange as it may appear, the writer once detected an experienced plumber in the act of fixing a water-closet apparatus over a lead trap inside a dwelling, which trap he had connected by a slip-joint to the soil-pipe. That plumber lost his employment through his wilful negligence; he was perfectly well able to make a safe and sound joint, yet he chose to make one that endangered the lives of the household, and, if not detected, would have caused his employer to forfeit his character.

The slip-joint on soil and waste pipes connected to drains is the kind which Dr. Teale illustrates in his book on "Dangers to Health," showing small devils issuing forth in a free and joyous manner, as representatives of sewer gases coming to inflict wounds and pinches on the unsuspecting members of the slip-jointed household.

The writer has in his possession, in a museum or chamber of horrors, numerous specimens of dangerous slip-joints removed from dwellings, where they caused individual illness and death, as surely as if the stroke was administered by the poisoned dagger of an assassin.

One is a slip-joint on a soil-pipe taken from a large hotel; the two pipes are held together by one lead strap to keep the pipes from parting company, in case the putty in the joint failed to grip!

Another specimen is a slip-joint between a water-closet trap and a soil-pipe, with two lead straps holding them together, and, to improve matters, the waste-pipe from a hot bath imperfectly soldered into the down of the trap, so that the hot water could have full play on the joint.

Another specimen is a slip-joint without either putty or strap, found open behind a pipe-casing in a servants' bedroom of a nobleman's mansion, one of the servants occupying that room having died from typhoid fever, and another lying for weeks at the point of death. This pipe

joined the drain direct, and the drain discharged into a close cesspool at bottom of a hill, with no interceptor between cesspool and house, so that cesspool gas was drawn into the house at this point, and at many others, day and night.

There has been enough said, however, to show that the lead slip-joint is the worst, most dangerous, and most unworkmanlike of lead-pipe joints in any position whatever.

The copper-bit joint (No. II) on soil, waste, or water pipes is always a weak joint, and, being easily made, we find it sometimes adopted by tinmen who set up in business as plumbers. This joint is made with fine solder and a copper bit or a blow-pipe. It may be fairly condemned, wherever met, as third-rate work on soil or waste pipes.

Such a joint is sometimes useful and sound work for connecting brass union couplings to lead water-pipes, or for jointing small light lead pipes or composition pipes for gas-fittings.

In making such joints on small pipes and couplings the writer takes care that all his workmen carefully open out the ends of the pipes to be connected with a box-wood tampin, instead of forcing out the ends, as is too often done, with the compass legs or the first tool to hand, and injuring the pipe by tearing it inside or thinning its substance needlessly.

No. III is a plumber's joint known as a taft joint. The under pipe is widened out as shown, rendering the stretched lead very thin; the part to take the solder is shaved bright, and the upper pipe, after being cleaned and shaved, is brought down and fixed in position, taking care to leave no space for solder to slip in between the two pipes; the solder is then poured or splashed on, and wiped round

quickly with the cloth in usual way, pressing the solder into close contact with the bright outer thin edge of the flange.

No. *////* is the plumber's wiped joint, not so easy to make as we might imagine while looking at the easy way any good plumber rapidly forms it.

The two pipes must have their internal edges carefully smoothed, for any projection or roughness will catch and retain threads, paper, etc., and eventually cause a block. Both pipes are opened out with a boxwood tampin, the under pipe just enough to admit the upper pipe about three-eighths of an inch, as into a socket, the bore being kept full size. Before putting the pipes in soldering position and fixing them rigid the end of the inner pipe should be smudged over to prevent solder running through and forming inside the joint.\* The writer had a joint made to show this danger to a class of plumbers, but the plumber who made the joint, unaware of the object in view, was so alarmed at the result that he scraped away the lumps of solder from inside the pipe, spoiling the good lesson, but teaching another, viz. that you cannot get inside the joints in real practice to do the same, and so care and caution are always necessary.

Many wiped joints are spoiled by want of care on the plumber's part to fix them in position before soldering, with end joining end, immovable and rigid. Better not attempt to wipe a joint at all than to do so with pipes loose, and liable to move during the process of wiping. It vexes the soul of a righteous plumber to see the wretchedly futile attempts made by even good workmen to secure their pipe-

\* The writer has a specimen joint almost stopped solid by solder, yet it worked under high-pressure supply for five or six years before it stopped up finally, and was thus detected and cut out.

ends firmly for jointing. They hammer chisels into walls and benches, they maltreat their compasses by forcing them till bent and twisted round the pipes, when a little consideration and care would enable the workman to devise an easy arrangement with short light timbers to do all they require for fixing the pipes without injury to walls or benches.

Overcast joints were very conspicuous in the plumbing work at the Paris Exhibition, for in Paris plumbers are doing their best to make wiped joints after our fashion, but have not yet quite succeeded, and therefore find it still desirable to overcast their joints; but when they have acquired the art of making a wiped joint as we do, simple and strong, the labour of overcasting will be omitted, as it has long been given up by us as unnecessary work.

Upright wiped joints are sometimes made by pouring on the solder from the ladle, and sometimes by splashing the solder on with a splash-stick. The hot solder should first be applied close to the upper smudge line, and, as it tends to fall, must be repeatedly pushed up. Rapid work is best, when joint is quickly and roughly formed. Work with hot iron and solder-cloth round the bulb, and particularly attend to press the solder with the cloth closely into contact with the pipe at the edges next smudge. Form your joint as round and symmetrical as you can, but do not spend time fiddling over it; let your joint be perfect at the back, at all events where it is not seen, and do not waste either time or solder.

In length let your joints present a happy medium, not too long nor too stumpy. A  $3\frac{1}{4}$ -inch joint should be enough, well made, for a 4-inch soil-pipe, 3-inch for 3-inch pipe, and  $2\frac{3}{4}$ -inch for 2-inch pipe.

Underhand joints are also best made when quickly made. The solder is poured from the ladle over the



smudged part of the pipe to get up the heat; then gradually and with a roundabout motion, the stream of solder is dribbled over the shaved part, taking care not to keep pouring on any one spot, as we often see beginners doing, and burning a hole through the lead, but as much as possible distributing your heat. With the solder-cloth continue drawing the solder, while pouring round and round the joint. Keep the hot lead dribbling on near the smudge line, and working it up from the bottom edges towards the centre. Wipe the solder well up against the under side, as, if hotter than necessary, it tends to drop off. Good workmen drop the solder on their cloth right and left hand alternately, and convey it to under side of joint, dragging the solder round from bottom to top, and then finally working round it with the hot iron and wiping it smooth.

All soil and waste pipes should be made with their spigot ends pointing in direction of the flow.

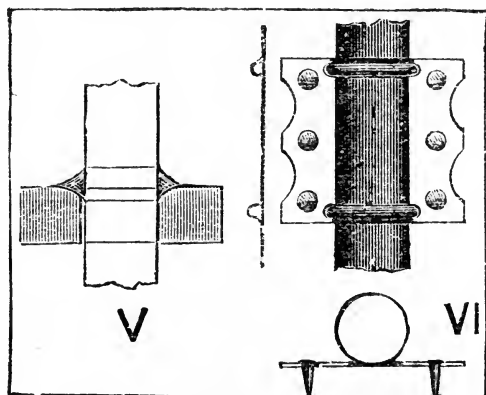

FIG. 141.—Varieties of lead-pipe joints.

No. **V** is a plumber's flange or block joint, used where pipes pass through, and are supported by a floor or a wood

block in a chase in the wall. The lower pipe is brought up about an inch or three-quarters of an inch above the floor or block; a sheet-lead flange is cut out to fit over this pipe, and is dropped over it, the pipe is then cut level to proper length for dressing back over the flange; the proper portions of pipe and flange are shaved bright and greased; the upper pipe is then duly prepared for soldering, accurately fitted in its place, secured, soldered, and wiped. This is a very strong sound joint.

No. VI is a moulded joint, sometimes used where soil and rain pipes are exposed on outer or inner wall faces. It makes a very neat joint, and is often seen in good old work, where its powers of endurance have been well proved. The mouldings are cast and soldered on with copper bit, and the joint is made also with copper bit. It is better suited for rain than for soil pipes. This joint is not much employed in the present day; undoubtedly the well-made wiped joint is superior in point of strength, and especially for soil-pipes.

Bending lead pipes needs even more care and skill than jointing them. Lead can be given any shape, if we use due skill to coax it. Bends should have wide sweeps; the plumber is in error who tries to make them sharp. The bore should be kept full size throughout, and the thickness of lead equal everywhere.

Take a lead pipe, heat it, bend it slightly; of course the lead thickens at the inner part and attenuates at the outer part, while the section bulges sideways and becomes flattened. The object now is to coax the thick lead from the inner round into the outer thin lead, and here appears the plumber's skill, only to be attained by practice at the bench.

Cast and drawn bends are now obtained so perfectly

made that bending is not so frequently a necessity, yet every plumber should be expert at bending in every required form. The practice of jointing and bending lead

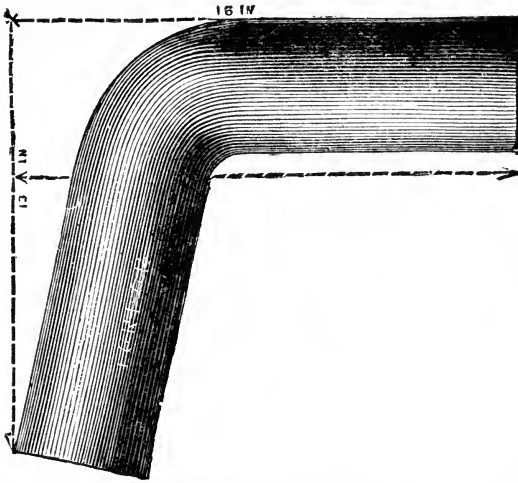

FIG. 142.—Lead bend.

pipes must be learned and acquired, not from book study, but at actual bench practice.

Branch work also needs care and skill. Branches from water-closets are generally made at the bench where possible, with the traps attached ready to lift into their permanent position. These branches should not be mitred into the soil-pipes, as it is almost impossible to avoid internal projections with mitred joints. An oval hole should be cut in the soil-pipe, small enough to leave plenty of lead for dressing out carefully, with a bent bolt, into a neatly formed socket, avoid bruising the pipe; then fit the branch pipe very accurately, entering it about three-eighths of an inch, not reducing the bore, and keeping it back also from entering the bore of the soil-pipe. Solder

must on no account be allowed to get inside. The smudge is neatly painted round the branch and the pipe, the joint is shaved bright and soldered as already described. No branch should ever enter a soil-pipe at right angles. It should always slope towards the soil-pipe, and the socket should be dressed to present a smoothly rounded curve when finished, for the soil to glide over from the water-closet.

The more sharply inclined is the branch pipe, the greater tendency to unsyphon the trap; therefore it is well not to give a greater incline than is necessary for clean flushing of the branch pipe.

In countries possessing climate similar to ours, all soil-pipes should invariably be carried up full bore and to the ridge level of roof, having a fixed, not a revolving extractor top, to induce upward and check downward currents of air. In some cases it is desirable to reverse the arrangement, and make the soil-pipe act as the downward fresh-air inlet, supplying the ventilating current to some more lofty shaft. It is not possible to lay down rules to suit all cases.

The sanitary object for the plumber to keep before him and to gain by any means within reach is to maintain a steady current of constantly changing fresh air through every foot of soil-pipe, waste-pipe, and drain, with the outlets discharging the air at a safe distance from windows, skylights, and chimneys, where the escaping air shall blow right away, and with the inlet arranged so that no offence can be caused by chance back draughts.

Many outlets of foul-air shafts can be seen fixed close to windows and just over chimneys, which may draw in the foul air and cause serious illness.

All branch waste-pipes, as well as soil-pipes, should be abundantly ventilated at the outgo of every trap, so placed and sloped that the soil water may not be thrown up into

the vent-pipe; and this pipe must be carried separate to above roof level, or it may join the soil-pipe vent-shaft above the highest branch intake.

This precaution is necessary, not only to maintain the movement of air through the pipes, but also to prevent violation of water-seal in traps.

The form of the traps best for various purposes requires consideration.

The points of a good sanitary trap are these:—A small internal surface and contents; every portion washed by every flush; total absence of sharp corners and edges; a good water-seal, yet easily cleared; a distinct open space

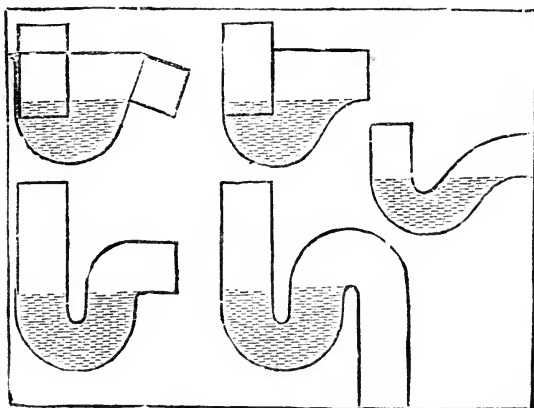

FIG. 143.—Various lead traps.

visible between inlet and outgo; resistance to syphonage in ordinary use when fully ventilated.

Many plumbers are faithful to the old **D**-trap, and will remain true till death. It undoubtedly is a good form to resist syphonage, but here its claim to consideration ends. Experiments will show that **D**-traps are not self-cleansing. They have a large internal surface, coated usually with slime and filth, from three to six pounds

weight of foul matter being found in them frequently. They have sharp corners and edges, and generally smaller water-seals than other traps, and so are liable to unseal by evaporation, or by capillary attraction working through some rag or thread over the side of outgo; but the greatest danger with all such traps (whether **D**-trap, Eclipse, or helmet shape) is that there is no open space visible between

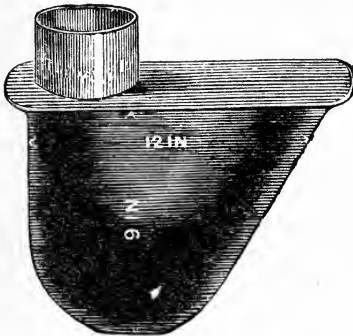

FIG. 144.—Helmet trap.

the inlet part on the house side and the outgo on the drain side. The division consists of a piece of sheet lead alone, and this is not visible, and is found sometimes with holes corroded through, giving free passage to the foul air and making the trap tenfold worse than useless.

This illustration of a helmet **D**-trap shows an attempt to get over the objection of sharp corners.

In round-way syphon traps, such a danger becomes manifest immediately to both the nose and the eye.

The ordinary round-way trap, if well made, as all such appliances should be, and of the **U**-form (in Fig. 143), not that with the sloping outgo, seems to have everything in its favour when efficiently protected by ventilation. It has small surface, small contents, is self-cleansing, has no corners, has open-air space between inlet and outlet, is easily made, easily fixed, and cheap, not being patented.

This form is with advantage made slightly reduced in bore, say a quarter of an inch at bottom of syphon, and considerably enlarged at top of outgo. The flushing water will always cleanse the enlarged portion, while the enlargement tends to reduce syphonage.

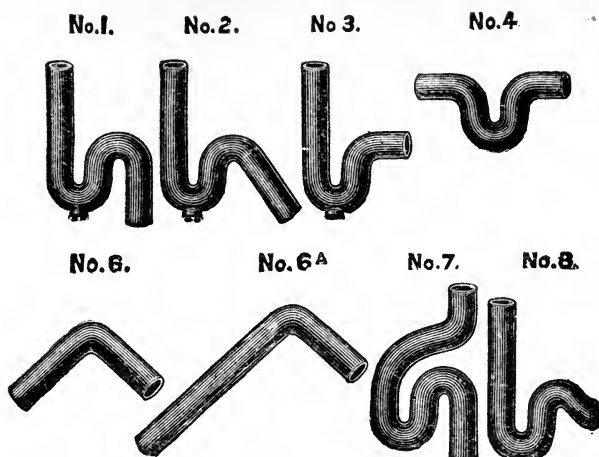
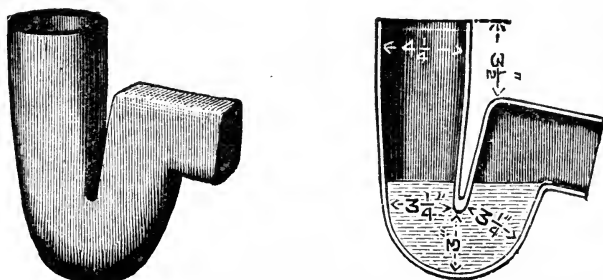

FIG. 145.—Various traps. Dubois drawn lead.

No. 1 is the **S**-trap; No. 2, half **S**-trap; No. 3, **P**-trap; No. 4, running trap; No. 6, short bend; No. 6A, long bend; No. 7, double **S**-trap; No. 8, special **S**-trap. All represent the best shape of their kind.

FIG. 146.—Anti **D**-traps.

Water-closet traps should have 2-inch water-seal at least, to allow for evaporation and other unsealing effects. Trough, bath, and basin traps may vary in depth of drown or dip from three to six inches, according to circumstances.

Fig. 147 shows the upper portion enlarged to receive the

brass end of the washer of the waste plug in a trough, so that the area of the waste may not be reduced, and the application of a brass cleaning screw at the bottom of trap,



FIG. 147.—Trough trap.



FIG. 148.—Bath trap.

suited for a bath or basin waste. These traps are cast of soft pure lead, without solder, and are smooth inside; they possess all the best points of good traps.

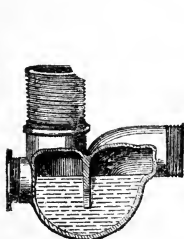

FIG. 149.

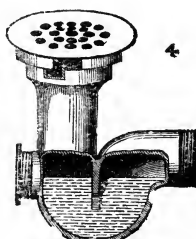

FIG. 150.

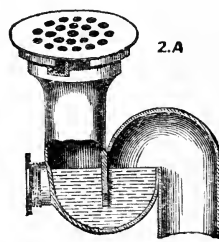

FIG. 151.

These traps show a compact form of trap with cleaning screw in front, but with the insanitary defect that no air space exists between inner and outer parts.

This mid-feather trap has the same defect, but is often used in lead-lined troughs, the brass grating being arranged to screw off for cleaning out the trap.

It is sometimes cemented into earthenware troughs, as shown in Fig. 153.

Bell traps with loose covers which lift out at will should



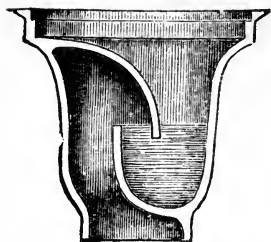

FIG. 152.—Mid-feather trap.

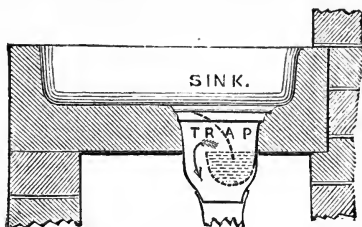

FIG. 153.

never be permitted in any position where a trap is required. The cover is invariably left off to enable tea-leaves, peelings, etc., to pass away freely, and then there is no trap or water-seal.

Traps with check valves or balls are always unreliable; the balls become coated with dirt, and in some forms drop from their seating if the water they float in leaks away or evaporates, which is the only time when the ball might prove useful. The precaution which such complicated traps are supposed to supply is unnecessary, when the waste-pipes are properly ventilated and disconnected from all doubtful drains.



FIG. 154.

The growing use of tinned-copper pipes for water service is a trouble to those who employ plumbers, and it is desirable that plumbers should not let this business slip through their hands. The writer has had difficulty in persuading his best workmen to tackle this work; they have pressed for coppersmiths and brass workers to be sent to help them to bend the copper pipes, while they, the plumbers, stand by and look on at the process in dignified attitudes, taking the copper pipes when bent and screwing them in position, but causing two workmen's time to be expended on work which one should do.

This concession, let plumbers be warned, cannot continue. Unless they acquire the art of bending and fitting copper and iron pipes, as well as lead pipes, the work will be altogether taken out of their hands, and there will remain the danger that the worker, who bends and fixes copper water-pipes, will find it necessary and profitable also to be prepared to fix lead water-pipes, for the two often run together in country work. The writer presses this matter strongly upon plumbers for due consideration ere it be too late.

The author does not believe in the possibility of teaching young plumbers their handicraft from books; the only way to acquire the skill necessary for a journeyman is the way of the bench in the workshop, under the guidance of an experienced craftsman. There are, however, certain evils to be avoided, which the author wishes to indicate for the benefit of young plumbers, as he has to point them out to his own apprentices from time to time.

In lining a cistern with lead, handle your lead neatly and carefully always; do not bruise or scratch it. Avoid the use of light lead.

If lining a small cistern with one piece of lead, do not forget, when cutting the lead, to leave half an inch to spare for the under-lap at corners, and also the proper square projecting pieces to form corner-joints where the lead turns over the edges of the cistern at top.

Avoid dressing the angles too sharp, or thinning the lead by over-dressing at any point.

Avoid shaving the parts for solder too wide, because the solder should cover the shaved space up to the smudged line.

Avoid dressing and working at the lead, and try to coax it into position by pressure rather than by hammering.

Avoid lifting the bottom lead off the bottom and leaving it hanging on the turned-over edges when finished.

Be careful, while soldering, to keep your lead flat to the timber; for if you solder your seam while the sides or bottom are bulged out by expansion, you will have trouble to dress them home afterwards.

Avoid having your solder and irons overheated, and do not try to do too long a seam at a stretch.

In lining moderate-sized cisterns, the author prefers to have bottom and sides in one piece of lead, and to have it smudged and shaved before being placed in the cistern. The ends should be cut full large, so as to press tightly home flat to woodwork.

In lining large cisterns, the bottom is generally a separate piece and heavier than the sides. The sides are put in first, preparing a turned-in edge to rest on wood bottom of cistern and an under-lap for corners, and leaving sufficient lead to dress out over the top edges when in position. When sides are fitted in position, prepare the bottom, drop it in, and dress it tight into the sides, ready for soldering; then mark and smudge.

Avoid the mistake of shaving too much at once. Shave a portion and solder it quickly, portion by portion, and avoid disturbing the lead while soldering. Lining large cisterns requires much practice for perfection.

#### LEAD BURNING.

This process, understood and practised by a limited number of plumbers, is one that should receive more attention, and ought to occupy a more prominent place in the trade than it does at present; it is a growing branch of the craft, and therefore one specially to be cultivated by technical teachers of plumbing.

Undoubtedly one of the subjects which plumbers will expect to be taught in a technical school is the art of lead burning. It is more practised in London than in the provinces.

Lead burning differs from ordinary soldering in the fact that no alloy is used in the process, no flux is required, the metals to be joined being united by self-fusion. When the process is really well done, the work is mechanically stronger, and chemically more secure.

Solder and lead expand and contract unequally by heat and cold; solder and lead in contact with moisture and heat, especially with acid moisture, form a galvanic couple, when the more easily oxidised metal is attacked and wasted away. In chemical works solder cannot be used in the leaden vessels and tanks, and lead burning becomes a necessity. Before the lead-burning machine was known, these joinings were made by pouring red-hot lead on the joints and fusing together with a red-hot iron, but the work was slow, troublesome, and clumsy.

Lead burning has been largely adopted in the dock-yards, and probably the demand for the process will extend every year. Solder alloy, being one-third tin, costs much more than lead, and is more easily oxidised, and it necessitates the use of fires for melting the solder and heating the irons, which fires are in many places extremely likely to set fire to buildings, and have often done so, and in other places have set fire to the tempers of the owners and servants of the house, and so the employment of solder in jointing forms both a material and moral menace to the plumber.

The hydrogen-gas generator is a very simple and safe machine, which may be left in a room or on a roof while the workman goes away to his meals.

In soldering lead the fluxes used are sometimes mis-

chievous, concealing minute fractures and faults, where the solder has not bitten or fused into the lead, while in lead burning the work is all under the workman's close, unobscured supervision, and every inch of the work is necessarily closely watched. The gas consumed in lead burning is a mixture of common air and pure hydrogen.

The hydrogen is specially made in the generator, and provides its own pressure, while the air has to be pumped by hand or foot, and delivered under an artificial pressure to the burner jet.

Blocks or cuttings of zinc are indifferently used, with diluted sulphuric acid—about six parts of water to one of acid—to generate the hydrogen gas.

The gas generator is made of lead, and all brass and copper parts are protected from the acid. The generator consists of two closed chambers, A and B. The lower chamber, B, is fitted on top with an opening closed by a screw stopper, c. Through this opening pieces of zinc are introduced until the lower chamber, B, is nearly filled, and the stopper is screwed down. The upper chamber, A, has a loose cover, D, on top, which lifts off freely, and also a fixed cover, E, or diaphragm, under the loose one, in which a large hole is made and hollowed downwards, and a small diaphragm, F, attached below the hole in the centre of the fixed cover. A tube, G, is connected from the bottom of the upper chamber, A, down through the top of the lower chamber, B, to within a short distance of the bottom, where also a diaphragm, or false bottom, is fixed, into which the tube is connected. The upper end of this tube is closed by a stopper, H, having a wire handle, and the upper chamber is then filled with the diluted sulphuric acid, until it just covers the small diaphragm, F, below the hole, leaving the space above the diaphragm as a reserve to prevent overflow of the acid.

The acid has not been allowed to come in contact with the zinc in the lower chamber. This is now effected by removing the plug from the tube in the upper chamber. A plug, T, for the removal of exhausted acid is arranged under the false bottom of the lower chamber. A box, or safety-chamber, S, is constructed between the upper and lower chambers, forming the chief support of the upper

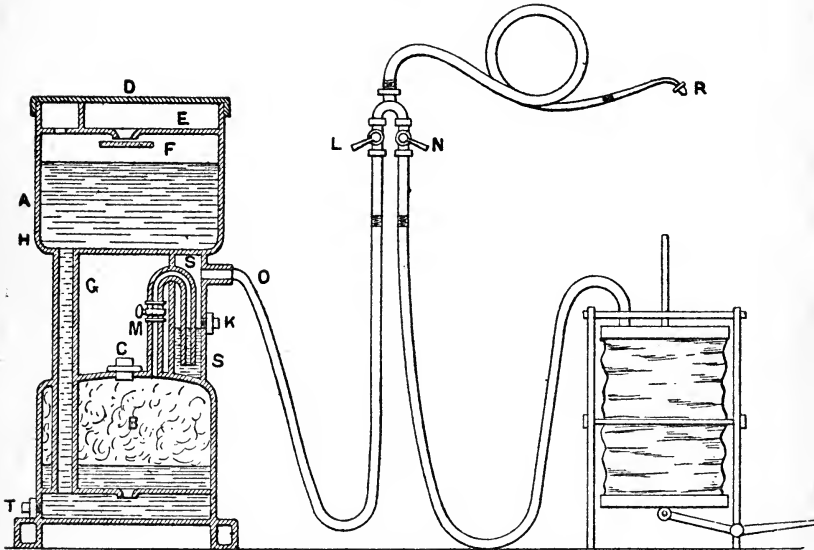

FIG. 155.—Lead-burning machine.

chamber. An aperture closed with a plug is made in the side of the chamber, three inches above the bottom, and water is poured in to form a water-seal or trap, into which a tube, K, is dipped two or three inches. This tube, K, is fixed vertically in the top of the lower chamber and fitted with a stop-cock, M; and before it reaches the bottom of the upper chamber it is turned into the top of the safety-box and down into the water-seal. The pipe by which the gas passes from the generator to the flame-burner is

taken from the top side of the safety-box; the possibility of any return of flame is absolutely prevented by this means.

It is well to know that if air was mingled with the gas in the lower chamber, and that a flame came back from the burner, or was carelessly brought into contact with the mixture, a dangerous explosion would take place. It is probably some nervous feeling on this point that has prevented the more general adoption of lead burning; but there is more danger every day in every house where gas-pipes are laid, or where a flask of gunpowder is kept.

The explosive nature of hydrogen gas mixed with air in contact with flame should be fully known, in order that a due measure of precaution be observed; beyond that, however, there is no cause for nervousness.

We now proceed: the stopper in upper chamber being removed and the cover replaced, the acid solution flows down through the tube, G, and comes in contact with the zinc in lower chamber. The stop-cock M is left open as well as the stop-cock L, which is fitted on the end of a flexible tube, O, leading from the safety-box, S; and as the solution continues to fill the lower chamber it expels the air through the safety-box and flexible tube to the burner, and the hydrogen gas, commencing to form immediately, follows the air, which will be found escaping in a jet under pressure at the burner, R, and, being tested by a flame, will act first as a blow-pipe till all air is expelled, when the hydrogen gas following will ignite, and is kept burning until all appearance of air mixture has disappeared, and experience tells that the pure hydrogen is forming in the chamber. The stop-cocks L and N are now closed, and the generation of hydrogen in the lower chamber proceeds rapidly, instantly raising the temperature of the chamber, so that the hand cannot remain in contact with it. You

observe that at commencement of the generation the largest amount of zinc is in contact with the acid, but as the pressure of gas accumulates it forces back more and more of the solution up the tube G into the upper chamber, thus diminishing and finally stopping the generation of gas, and so acting as a perfectly efficient automatic regulator.

As we have finished with the generation of hydrogen, we can let it stand a moment while we examine and prepare the other portions of our apparatus.

A pressure of common air is required in the process, and this may be supplied by any convenient means which will give a gentle, constant, and even pressure—a pair of double bellows worked by the assistant, or, in case of necessity, by the lead-burner himself; and a weight is arranged on the bellows to maintain a steady pressure of air, which is conveyed to the worker through a flexible tube any convenient length, similar to the tube conveying the hydrogen gas. Both tubes are united to a brass connection having two stop-cocks, L and N, one for the gas and one for the air. From this brass connection (which may be fixed or loose) a flexible tube is extended to the burner-jet, which the workman holds in his hand; these jets require to be well made to give a true pointed flame, and they may be kept in various sizes to suit the character of the work in hand. The flexible tube from the stop-cocks to the burner need not be very long, as the workman requires to handle it easily, and also to be within reach of the stop-cocks, to alter or regulate pressure at will.

As soon as work commences and gas is consumed, its place is at once supplied in the generator by the descent of the solution upon the zinc again, generating more gas, until the accumulation of pressure again drives the acid



solution back ; and so it goes on for three or four days, after which time in constant use the liquid becomes changed into sulphate of zinc, which is then drawn off at the vent, T, and the machine recharged as before. Experience and practice alone can teach a worker how to regulate his flame to the proper point to suit his work, and the same remark applies to the work itself ; but there is no difficulty about lead-burning work which any good neat workman cannot overcome by practice in a month's time. Nothing but actual practice of the work can teach it practically.

The lead to be joined by burning must be steadily secured in its place, either edge to edge or lapped over jointing, and must have the parts to be united scraped bright and the jet of flame regulated and applied, a thin strip of pure lead being held in hand to supply any deficiencies observed during the progress of the burning.

## CHAPTER VII.

### SANITARY APPLIANCES.

ALL sanitary appliances should possess certain common qualities; it is the duty of plumbers to examine and study every detail of every appliance, whether old or new, before they recommend or adopt it in their business. There are many sanitary exhibitions held, no doubt, where experienced judges examine and decide on the merits of new inventions, and award prizes and commendation which very properly serve to guide the general public; but we cannot fail to have observed, among the multiplicity of awards, many given to appliances which practical men cannot endorse. It is therefore necessary that we should be capable of examining appliances and forming our own unbiased personal judgment. A practical plumber should be able to form a better opinion on the merits of any appliance used in his trade than any professional gentleman merged in a committee of examiners. The study of actual apparatus in detail is one of the important features of a technical school of plumbing.

The qualities required in all sanitary appliances are durability, simplicity, accessibility, cleanliness, and general effectiveness.

Durability is placed first, because sanitary appliances are often neglected and soon forgotten, and thus, no matter how simple, accessible, clean, and effective they may be when

first purchased and fixed, they do more harm than good if they fail in their action from want of durability in material or construction.

For instance, take, as an example, a water-closet cistern.

It may be simple, clean, easy of access, and effective, yet, if it corrodes into holes in twelve months, it fails utterly in the most important quality of durability.

It may be durable, clean, and effective, yet, if it be complicated with valves, chains, and levers, the absence of simplicity will cause constant expense and trouble.

It may be durable, simple, and accessible, and yet not be effective, by failing to fulfil its purpose.

It may be durable, simple, clean, and effective, and yet may fail, owing to the inaccessibility of some simple part which cannot be got at without pulling all to pieces.

The first sanitary appliances for the plumber's consideration will be water-closets; they are not found to be the most dangerous of house-fittings as a rule, because they are more suspected, and therefore more closely looked after.

Let us have, first of all, an illustration of the old pan water-closet, till lately the sign and ornament of the plumbers' shop windows, and let us consign it unsparingly to the limbo of the most hopelessly condemned insanitary appliances. Like many other meretricious inventions, it for a time superseded, because it was cheaper, Bramah's valve-closet, its superior in every particular; both, however, are now set aside by others and are out of date. When pan-closets are removed from dwellings they should be at once broken up as scrap metal; they are more valuable as old metal, and certainly less dangerous than as pan-closets. Some plumbers have sold them to jerry builders for a few

shillings, but such traffic is of doubtful morality, and therefore to be scrupulously avoided by honest tradesmen.

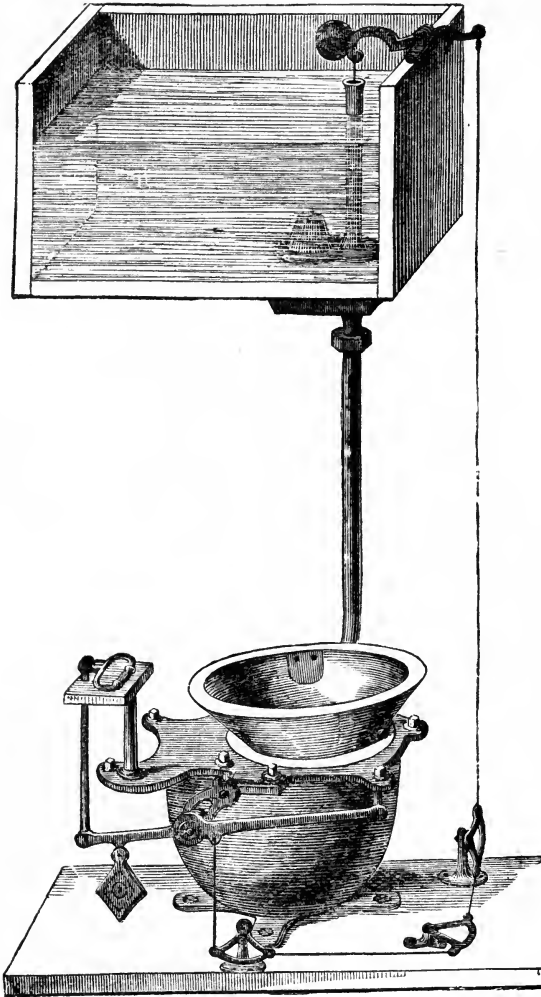

FIG. 156.—“Ye old pan water-closet, condemned to death.”

In mitigation of the evils of the metal trunk container of filth in pan water-closets, some makers have enamelled

the containers, and others, even eminent as sanitary manufacturers, offer them with stoneware containers; but take a friend's advice, if you are responsible for the sanitary condition of a dwelling-house, and do not recommend a pan water-closet under any form or material.

It frequently will occur, we are sorry to say, that you will find pan closets already in possession, and an owner or landlord in the enjoyment of these antiquated appliances, who declines to have them removed, on the ground of expense and long usage. In such cases it will be the engineer's or plumber's duty to protest and explain his reasons for protesting; but he will be within his right and duty in obeying his employer's directions, and making the best of a bad business. It is not the plumber's duty to dictate on such matters to his employers.

Plumbers have endeavoured to improve these pan closets by adding a 1-inch diameter lead vent-pipe to the metal trunk, and others have added 2-inch diameter lead pipes, in the hope of obtaining a ventilating current of air through the trunk. These pipes, if carried into the open air, do no harm beyond complicating the apparatus, but they do very little good indeed.

Common earthenware, stoneware, or enamelled iron conical Dill water-closets are also to be condemned. They are very frequently found fixed in closets intended for servants' use. One can hardly understand that any reason can exist for placing an insanitary form of apparatus for the use of persons less likely to be particular as to usage and cleanliness than their more educated employers, especially when such closets are generally situated in the basement, whence any defect in cleanliness must affect the upper house. They are not fit for use as closets even in a garden house; the soil clings to every part of the conical basin, as experience proves, and no flush of water can keep them cleansed.

The Dill conical basin, illustrated below, is suited only for use as a slop-sink, but is constantly fitted up as a servants' closet. The writer has seen the water-flush rising

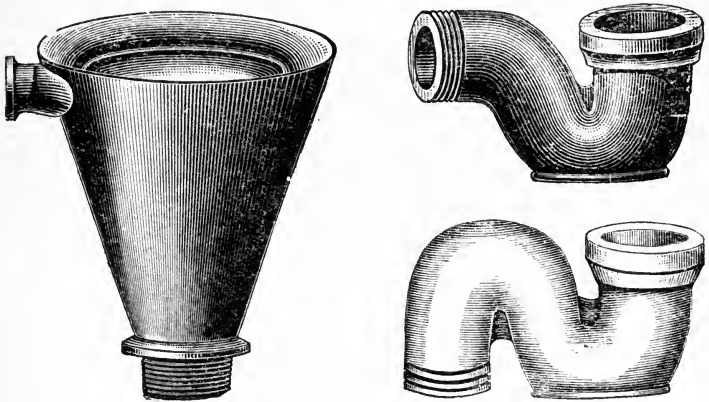

FIG. 157.—Dill water-closet basin and traps.

up by centrifugal force in them, and overflowing by the top, instead of passing away by the trap to the drain.

The wash-out water-closet is no longer in favour; it has served its purpose in sanitary progress and has given place, as the writer expected, to better forms at the present time. Here are various illustrations for comparison (Figs. 158, 159).

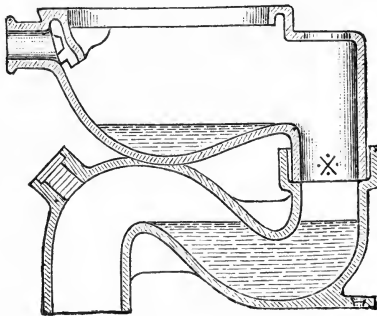

FIG. 158.—Wash-out water-closet in two pieces.

It may be noticed that these closet-traps have no proper

provision or flange for safe connection with lead or iron soil-pipe, and consequently they are unfit for use inside a dwelling, and should only be employed in an outside closet, where the trap would be cemented direct to an earthenware

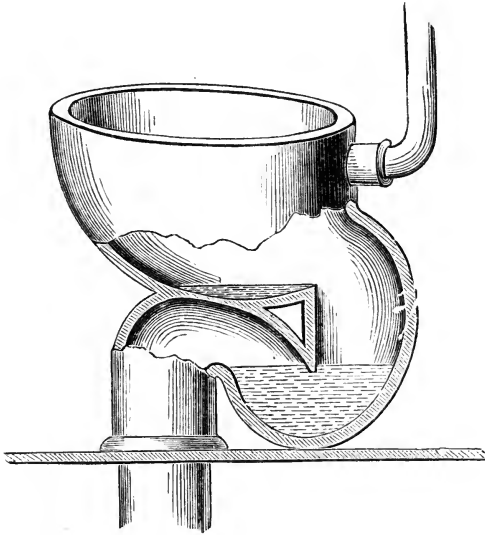

FIG. 159.—Wash-out water-closet in one piece.

drain-bend. The depth of water in the basin of Fig. 159 is quite inadequate, and without an after-dribble the basin would be emptied at each flush by momentum. The water seal of trap, also, is defective, and would be highly dangerous if used thus in a dwelling-house. There are much better forms of the wash-out class than these.

We here illustrate (Fig. 160) another form of the wash-out closet, in section and elevation. It is made in one piece of pottery ware. The junction flange with soil-pipe is well exposed for examination; it is not shown wide enough for screwing down securely. The trap and drain are carried better into view in the section arrangement. The water for

receiving the soil is somewhat deeper than usual, and an after-flush is secured by the small after-flush container shown at the back. A vent-pipe horn is provided on the

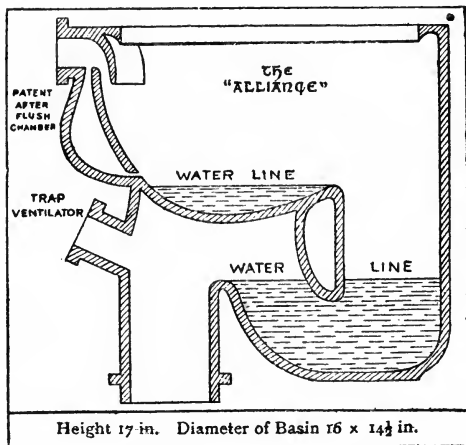

FIG. 160.—Wash-out water-closet in section.

outgo of trap; but the two corners shown in the water-way under the basin are palpable defects, where soil would surely catch and remain untouched by the flush. The basin is well scoured at every flush by the direction communicated to the incoming water.

We have an independent wash-out closet in this illustration (Fig. 161), and we see that the defect caused by the two corners in the soil-pipe under the basin has been here removed, and a continuous pipe syphon is shown, quite self-cleansing. All other improvements are shown; but the flange junction with soil-pipe is not nearly wide enough, and is not quite apart from the body of the apparatus, and therefore cannot be so readily seen and examined. This objection can be got over, but great care in fixing will be called for.

The "wash-out" form is now obsolete. The objections to this closet seem to be—



1. That the trap, made of earthenware, may be badly connected with the soil-pipe, so as to admit drain air to the house, either by defective packing or by the flange cracking across by too great a strain from the screws.

2. That the trap is not directly in view, and may retain soil unnoticed, and may also lose its water-seal without the danger being discovered.

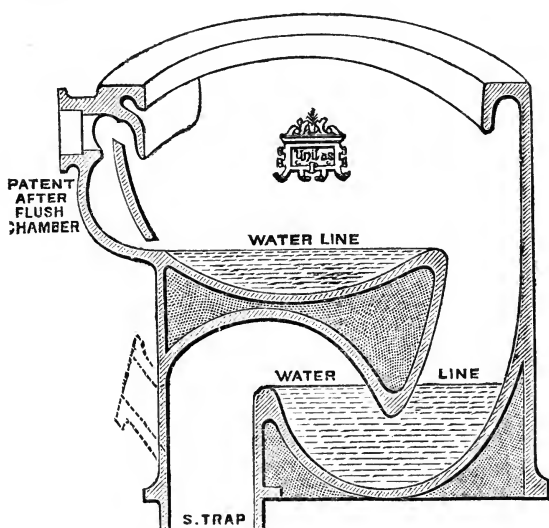

FIG. 161.—Independent wash-out water-closet section.

3. That although there is a layer of water to receive the soil, it is not deep enough to cover over the soil and stop odour from it, nor to preserve the basin from impurity, and that this impurity is not always washed out by the flush.

The latter objection may be lessened by having arrangements for a strong and full flush.

Special ornamental forms of wash-out closets are now made to stand exposed and independent, without wood casings, and with hinged wooden seats to allow of slops being thrown in when the hinged seat is turned up. They

are subject to the same objections as any other forms of wash-out closets. All such closets have the trap over the floors. As compared to pan water-closets, these are greatly superior in a sanitary point of view.

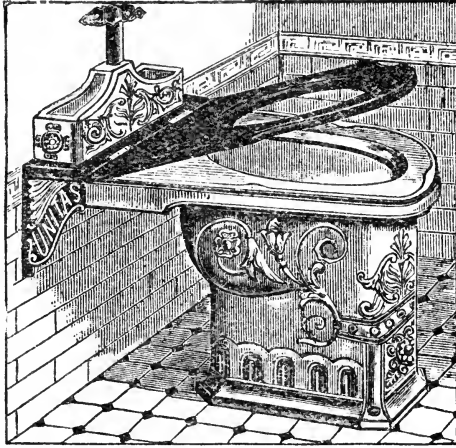

FIG. 162.—Ornamented independent wash-out closets.

The best of all the simple sanitary forms of water-closet is the wash-down. It fairly fulfils all the requirements named at starting, and in our opinion deserves high commendation.

A very considerable experience of this form of closet in action, in the face of strong opposition, only confirms us in our good opinion of its advantages.

The best possible form may not have been reached yet, but the attainment is open to every man who has perseverance to bear with disappointments, and a little time and money to spend on experiments.

This arrangement of compound closet, available as water-closet, slop-sink, and urinal, consists of earthenware or porcelain basin and trap in one piece, standing independent on the floor. The seat, supported on cast-iron brackets, is

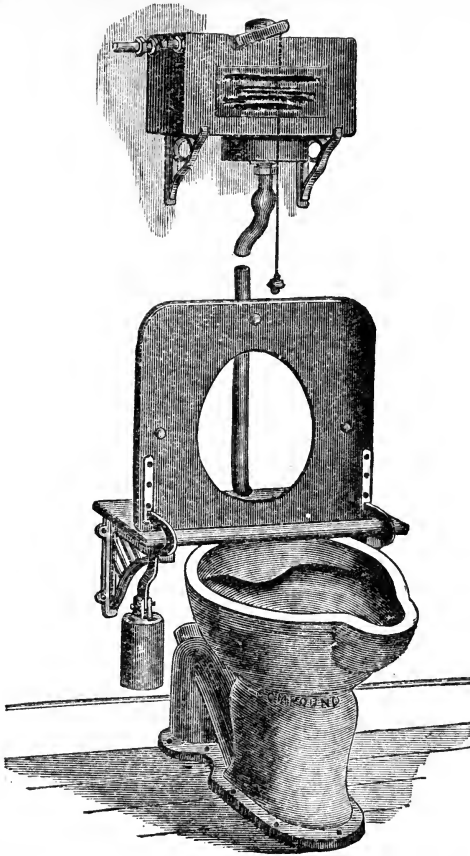

FIG. 163.—Compound water-closet, sink, and urinal.

balance-weighted to remain raised open unless when pressed down in use. Any form of cistern may be adopted, having an after-flush.

The form here illustrated (Figs. 164, 165) exhibits the earliest effort to secure a sanitary form of wash-down water-closet; it has been discarded for better forms suggested by long experience and observation as being free from defects, which became noticeable in these early forms in use.

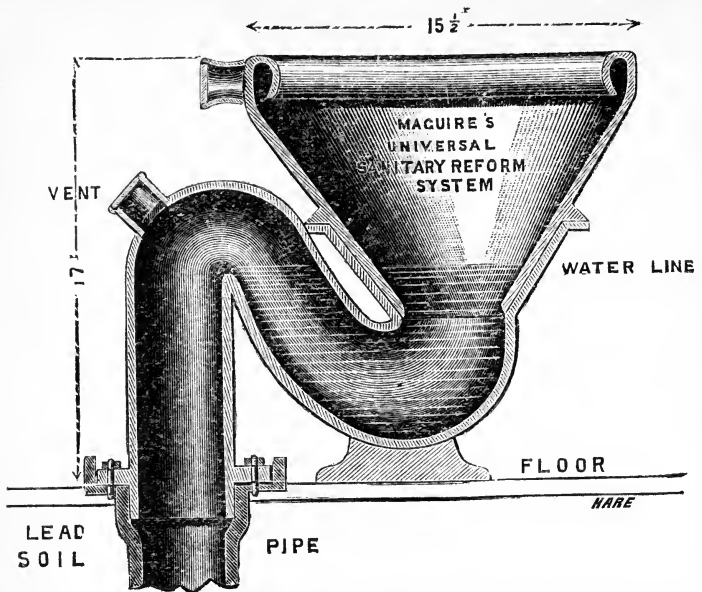

FIG. 164.—Section of original form of wash-down water-closet with basin in usual position.

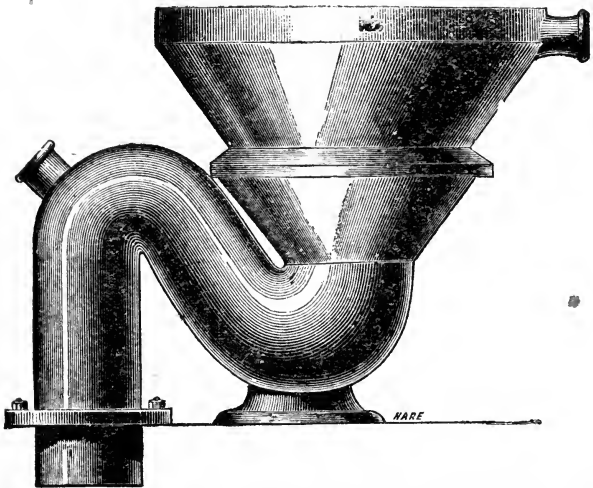

FIG. 165.—Elevation of original form of wash-down water-closet with basin reversed.

The basin has a flushing rim constructed in the best way for throwing a body of water on the paper and soil, while a strong flush is also scouring the sides of the basin. The basin is similar in form to that of the pan water-closet flushing-rim basin.

The trap may be made of porcelain or of iron enamelled, but with these the junction to the soil-pipe needs special care to ensure safe and durable connection with the soil-pipe, which must be flanged over the floor to receive the iron or porcelain flange tightly screwed down on it, and then dressed up over and round the flange with red-lead cement bedding.

The trap has a deep drown, so as to bring the water well up into the basin that the soil may drop into water, and a lead cone is soldered to the trap, reaching half-way up the basin, so that if the basin be removed, the cone and trap still retain the same depth of water standing in them; and during the flush, when water rises a little, no overflow would occur, even if basin had not been properly bedded in the lead cone.

The basin and trap both stand accessible above the floor on the lead safe-tray, and the soil-pipe passes out at this accessible level, which is a most important advantage and security.

The deep drown of trap prevents risk of evaporation withdrawing the seal, but as the water-seal is in sight this point always reveals itself. The service-pipe should be at least one and a quarter inch and the service-valve two inches in diameter to secure ample flush.

The trap and its seal are directly in sight and accessible, so the trap can be cleaned and cleared without trouble. If it ever choke, it will occur within easy access for cleansing.

The position of the trap shows at once whether the flush

has cleared away the soil and paper from the premises, because, once gone from the trap, there is no other receptacle to retain them. In a pan or even valve closet the concealed trap beneath may retain, as it must receive them.

The soil-pipe of this form of closet must be ventilated full bore, and should be treated as the smoke flue of a stove and carried to a point clear of blow-down, and surmounted by a simple form of extractor.

The outgo of the trap also should be ventilated as already described, and all other appurtenances arranged in sanitary form.

The wash-down form of closet will come more to the front, as the public and the plumbers realise that simplicity is sanitation in earnest.

The trap and basin are in two parts, and the basin can be turned about at will to bring the inlet directly opposite the service-pipe, and to give the flush the best direction for driving off the paper quickly.

The pull may be arranged by cranks and wire from the seat up to a service-valve in cistern, or to a waste-preventer cistern, or to a regulator and valve under the seat. The best arrangement is a long pull formed of brass or plated tube, with neat hanging knob or handle fixed on the face of the wall from the lever of the cistern-valve, so that every working part of the apparatus may be exposed and easily accessible.

An improved form of wash-down water-closet is now made in one piece of earthenware, which possesses certain advantages over the original form.

The basin is made with the back sloping away and the front more sloping than usual, giving an oval form and greater area to the water surface, and bringing the water into a better position to receive all the soil, some of which occasionally falls on the back part of the common form of wash-down, needing an extra flushing to cleanse.

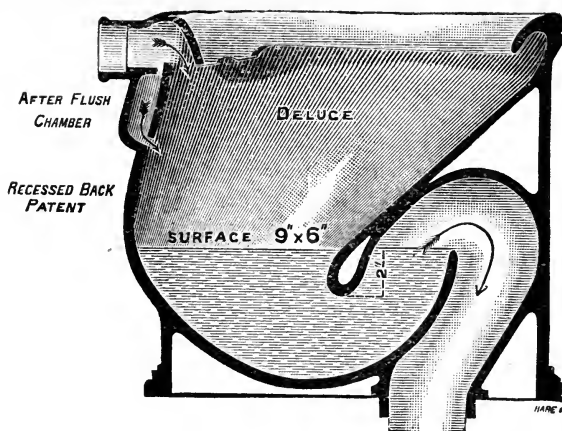

FIG. 166.—Deluge improved wash-down water-closet.

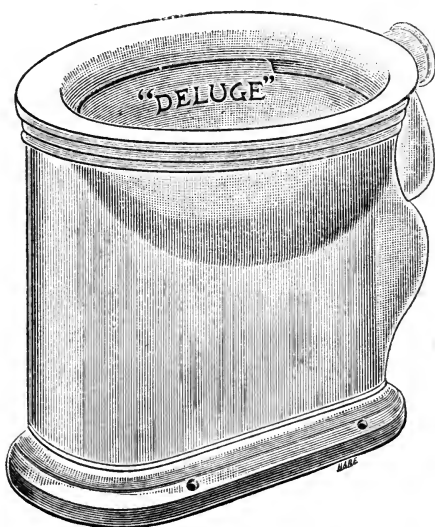

FIG. 167.—Deluge improved wash-down water-closet.

This closet must be always fixed in the one position. It may be used with or without an enclosing wood-casing, and forms an excellent water-closet of a cheap type.

The Adamant Deluge Closet is specially recommended for Asylums and Institutions where hard usage must be provided for.

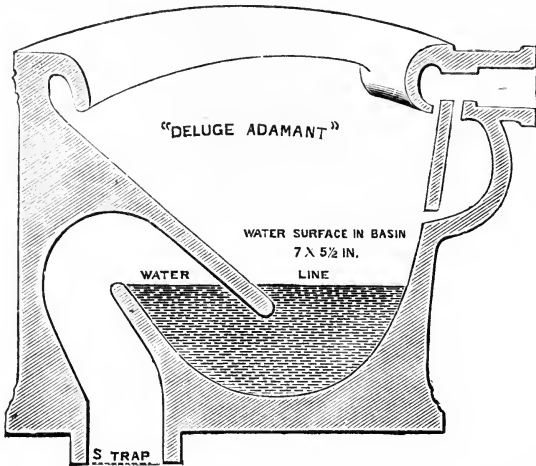

FIG. 168.—Deluge Adamant improved wash-down water-closet.

The flushing pipe should be one and a quarter or one and a half inch in diameter.

Where sufficient head room cannot be found for ordinary flushing cisterns, a combination arrangement of cisterns and closet is adopted. A large inlet horn or arm, six times the capacity of an ordinary horn, is made in one piece with closet. A cistern, on single or double valve principle, with an outlet valve correspondingly large with inlet arm of closet, is placed at the back of closet, and connected direct to that inlet arm. They are also supplied with valveless syphon cisterns. When cistern-valve is lifted the contents of cistern are precipitated with one gulp into the basin, which is made with flushing rim, thoroughly washing out the basin and trap, and leaving a larger quantity of water in basin than usual with wash-down closets. The instantaneous character of the flush gives this closet an advantage over



all others for thoroughly clearing out the trap and flushing the drain every time the handle is pulled. An after-service box is constructed in one piece with the closet, as a safeguard against the tendency that exists in closets of the



FIG. 169.—Combination wash-down closet.

wash-out type to leave too little water in the basin, or the unsealing of the trap by syphonage.

The wash-down water-closet is also made with a patented douche arrangement of great use, especially near the surgical wards of hospitals or in doctors' houses, where examinations are made or operations are performed, or generally for persons suffering from hæmorrhoids, etc.

The douche is quite separate from the flush arrangement, and is only used when required. The small supply cistern

is fixed on the seat beside the user, and can be easily filled with water at any desired temperature, and, if necessary, medicated. The application of the douche is given by actuating a handle-pull, which opens a valve and allows as much or as little water as desired to pass in douche form, as shown, to cleanse the person.

The form adopted for this addition to hospital and nursing hygiene is the wash-down closet. The apparatus is formed of pure, fine ivory porcelain ware, most cleanly, owing to suitable shape and high class of glaze, giving a large water surface to receive and cover excreta, and a strong water-flush, with deep water trapping.

The advantages of the patent douche closet appear to be:—1. It is made of pure glazed porcelain ware, and has a remarkably good appearance. 2. It has no complicated machinery and is incorrodible. 3. The trap and all parts are within easy reach for cleaning by hand or brush. 4. The water-seal can be always seen, and it cannot be syphoned out unnoticed. 5. The water-flush removes all soil from the house the instant it passes from sight. 6. The odour is reduced to a minimum during use—a very important advantage. 7. It affords a secure joint with the soil-pipe when care is used. 8. It is always pure and clean, and cannot cause bad odours. 9. No drain-air can return from it, as the water-trap is always in sight. 10. It affords perfect cleanliness of person. 11. It enables medicated waters to be applied locally. 12. With cold-water douches strength is imparted and recovered. 13. Trap and all appliances are over the floor and easily examined. 14. Ventilation of trap perfect, and trap absolutely self-cleansing. 15. It cannot get out of order, nor can there be any undetected defects. 16. It is easily fixed. 17. It is a most soothing appliance for inflamed hæmorrhoids, etc. 18. It prepares the person for surgical examination and operation.

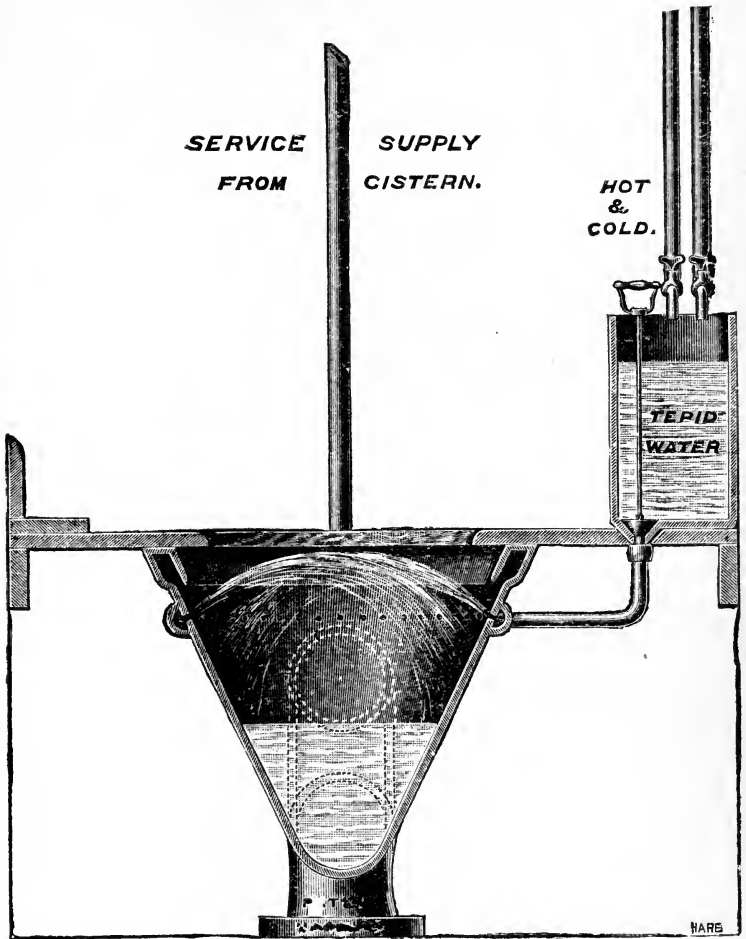

FIG. 170.—Douche improved wash-down water-closet.

The author wishes to incorporate at this point the published opinions of another sanitarian concerning the relative values of valve, wash-down, and wash-out water-closets, illustrated by sections of the different closets, showing the action of the water during flushing.

The valve closet is superior to any water-closet yet known

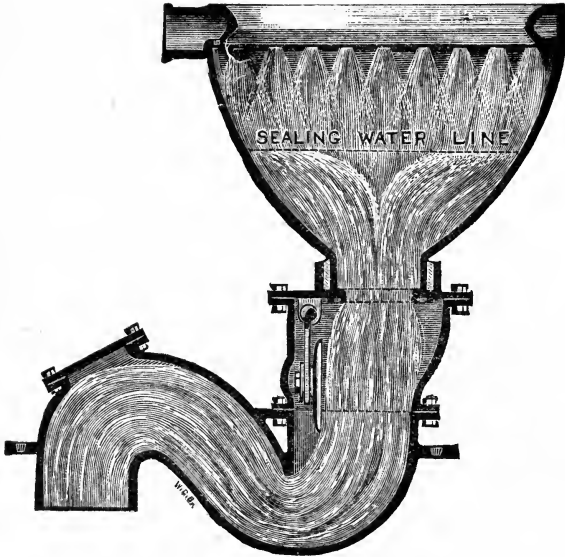

FIG. 171.—Drawing showing the flushing of valve water-closet.

for the following reasons:—The outlet hole of basin is covered with clean water, preventing the air of the room becoming contaminated by any foul water that might be in the trap, so that, in addition to the ordinary trap, there is a sound valve covered with clean water, to prevent any possibility of gas escaping into the house through evaporation or syphoning of the water out of the trap. The sealing water covers that part of the basin where the soil falls, preventing adhesion. When the closet is operated, the

sealing water, weighing about twenty pounds, more or less, is suddenly dropped into the trap, carrying everything with it. The regulation 2-gallon flush is then discharged into the basin, flushing it at all parts, as well as the trap, which it leaves full of clean water. The water is discharged in the direction of the outgo, so that the force of the flush is unchecked.

The wash-down closet is superior to any water-closet of

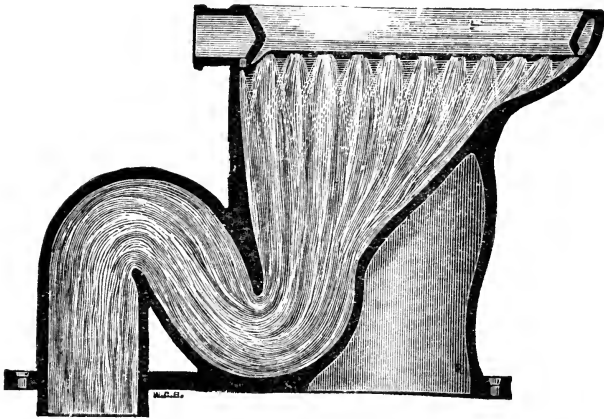

FIG. 172.—Drawing showing the flushing of compound closet.

the wash-out, pedestal, and others of that class for the following reasons:—The force of the flush is exerted directly on the water remaining in the trap without any change of direction. There is no cup in which the flush water is broken up, or the soil washed about, neither is there any part of the basin which is not subjected to the direct action of the flushing water.

The use of closets commonly called “wash-out” (but for which “*wash-about*” would be a more correct term) is objectionable for the following reasons:—The force of the flush is nearly destroyed by the change of direction necessary

to remove the water and the soil from the cup A over the weir B. Its force is still further spent against the front wall of the basin C. The current of water being thus broken up, the soil follows the various eddies and adheres to the vertical walls of the approach to the trap at C, where it is unsightly and contaminates the air of the room. The power of the flush, being almost entirely destroyed by two changes of direction at right angles before it reaches the

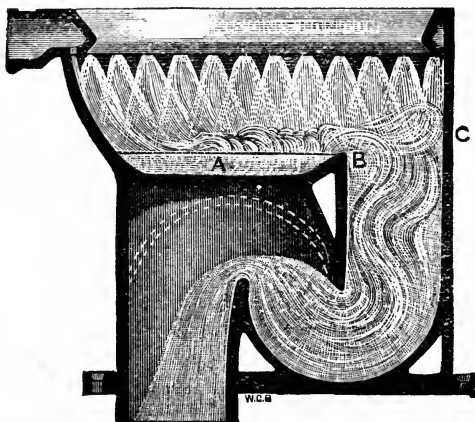

FIG. 173.—Drawing showing the defects in the flushing of "so-called" wash-out, pedestal, and other closets of that class. Some of these closets are made with the trap as shown by the dotted lines in the engraving.

trap, is frequently insufficient for clearing the trap at each discharge, the soil consequently remaining in the trap till the closet is used again. In this way, not only is the air contaminated, but the water in the trap becomes foul and injurious to health. These closets have not the advantages of the valve closet in having a valve at bottom of basin covered with water to prevent the possibility of the contamination of the air of the room by foul water contained in the trap or escape of gas, caused by the evaporation of the water in the trap or by syphoning.

A further modification of the wash-down type has been made in enamelled and galvanized iron for barracks and

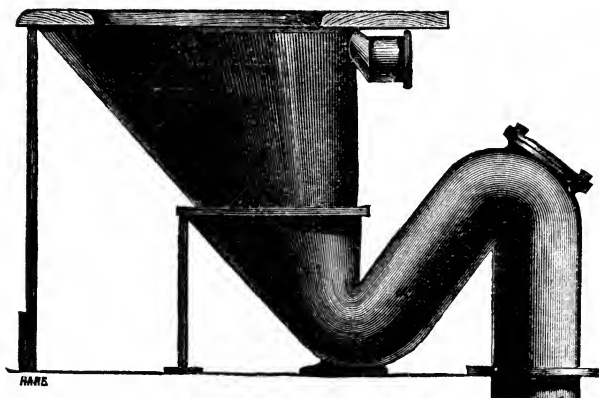

FIG. 174.—Elevation of barrack wash-down water-closet.

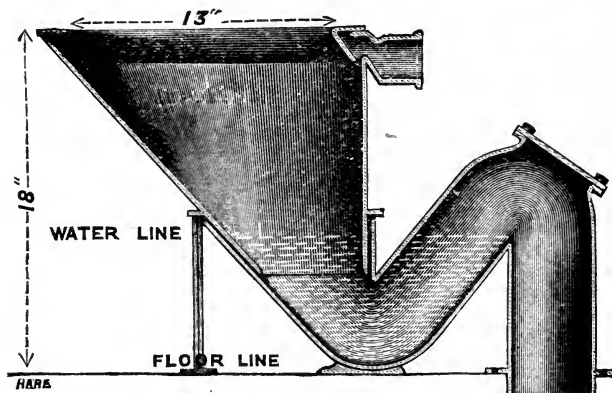

FIG. 175.—Section of barrack wash-down water-closet.

institutions where rough usage is foreseen. The seat-opening is set two inches further back than usual. Wisps of hay, being often improperly used in place of paper, require the larger 4-inch trap and outgo, and the back is made perfectly upright, all the slope being given to the front. This form

has been adopted by the War Department for several barracks. The basin and trap are separate castings. This form of water-closet has been made with trap in one piece of earthenware, under various names; but our object is to induce you to try your own experiments and to make them for yourselves, improving on them as you proceed, till perfection is attained.

There is another arrangement of this wash-down form which has, in addition to flushing rim, a substantial jet of water forced straight at the centre of the water, to drive all soil out through trap quickly. This closet is fixed with the trap and inlet sideways to the seat.

The wash-down form of closet has now been well tried in actual use in private houses, in club-houses, hotels, and railway termini, and it has answered all purposes well. Technical teachers of plumbing should not dogmatize upon the advantages of any particular form of sanitary apparatus; they may state their opinions freely as such, and ask their hearers to judge of them for themselves, and take them for what they are worth.

As in the present instance, a lecturer or teacher may state that in his opinion the wash-down closet form is the simplest and best, and he should give his reasons; but so many first-class plumbers and sanitarians adopt and prefer other forms which they have found satisfactory, the matter is eminently one for the exercise of judgment. If the students are stimulated to examine, inquire, and experiment for themselves, the teacher's object shall have been effectually gained.

Trapless water-closets are commended by some experienced sanitarians, with whose opinions on this detail of plumbing we are unable to agree.

We illustrate one form of these closets. The maker



states that, when fixed on well-ventilated soil-pipes, this closet requires no trap beyond the plug, or stand-pipe,

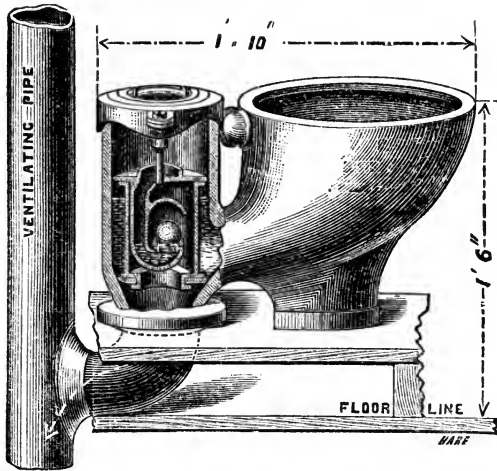

FIG. 176.—The safety-plug trapless water-closet.

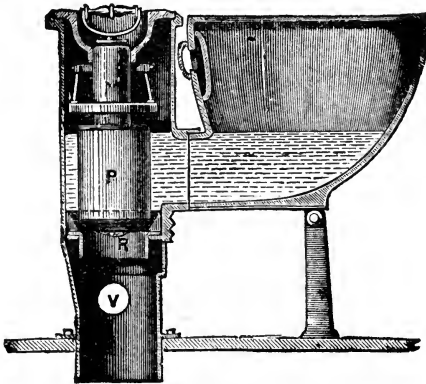

FIG. 177.—The trapless plug water-closet.

which retains the water in the basin. Upon raising the plug, the contents of the basin passing down the soil-pipe carries with it a current of air, preventing any upcast.

In this respect all valve closets and the twin-basin

closets are equally suitable for use, without traps or as trapless closets.

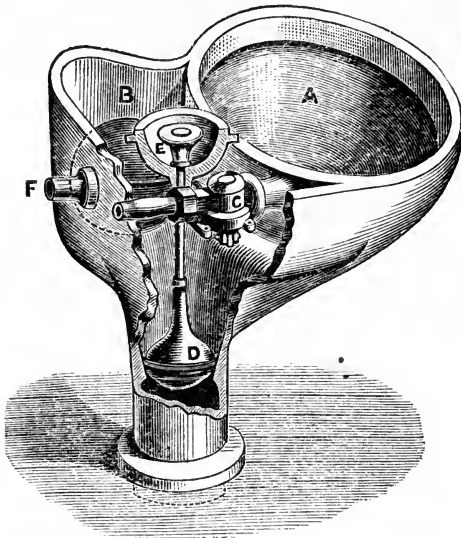

FIG. 178.—Trapless twin-basin water-closet.

In trapless closets it is possible that the plugs or valves may leak, the water may pass away, and allow the soil-pipe

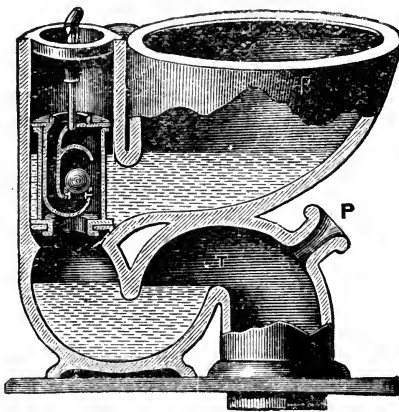

FIG. 179.—Safety plug-valve water-closet, trapped over floor.

air to be drawn into the house; also it frequently happens that servants or children may fasten up the handle, and leave the valve or plug full open by neglect or inattention, and the air of the soil-pipe is then drawn full bore into the house, and this may in such a case go on for hours or days, and cause illness. The precaution of providing a water-trap under every water-closet, without exception, is therefore good sanitary engineering.

These plug-valve closets are frequently complicated, easy to put out of order, difficult to regulate and repair. The water flushes the basin so quietly that cleansing is frequently inefficient, part of the basin over the plug is never flushed, the overflows also are liable to become foul.

The advantages of syphonic-action closets have been somewhat counteracted by defects in construction. The closet shown on page 256 seems to get over the objections of complicated details. There is only one trap, with 8-inch water-seal, and there is a large surface of water maintained in the basin. The direct action of water in service-pipe starts the syphonage, and the contents of basin are easily discharged thereby, and basin is refilled immediately from the service cistern. The closet joint is always under water, and the trap being of lead is securely wiped on to soil-pipe.

In fixing this closet care must be taken not to cut or alter the lead trap. The soil-pipe should be 3 inches in diameter and have a clear fall, and there should be no second trap, unless an intercepting drain trap in open air with grating.

The Betterment closet (Fig. 181) provides a brass trap, which the plumber can connect safely to soil-pipe by a wiped joint. In places subject to rough usage the brass trap will prove more reliable than an earthenware trap.

The plumber should make himself acquainted also with the new system of grafting lead or metal pipe on to the

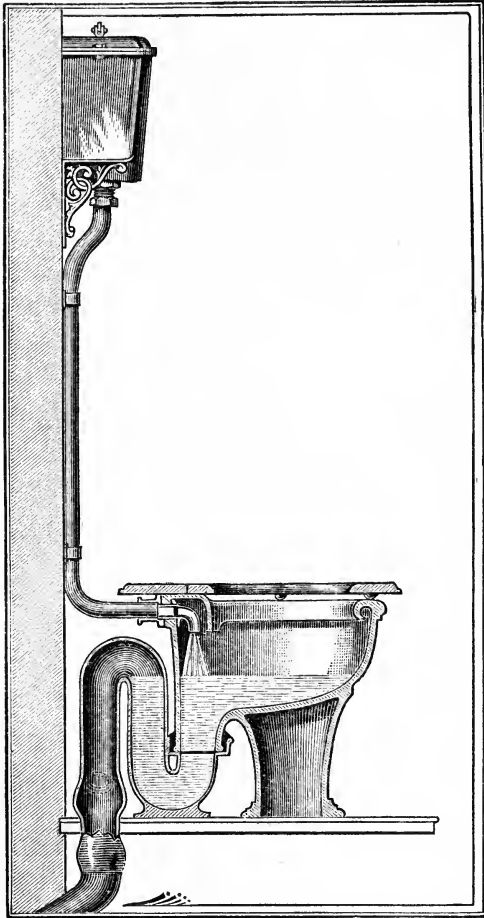

FIG. 180.—Syphonic closet.

earthenware outgo of water-closet traps. The lead is actually so well connected by some makers that even when the trap is broken the lead will not separate from the earthenware.

By heating thoroughly the earthenware portion of the trap it is also possible to make a good joint with molten lead between a lead soil-pipe and an earthenware trap; but the writer is not in favour of this in actual work, though he has made the joint described satisfactorily. It needs more care to make the joint well than an ordinary plumber can be expected to bestow upon the work.

The attempt to describe every water-closet offered in the market would be tiresome and unnecessary; every maker

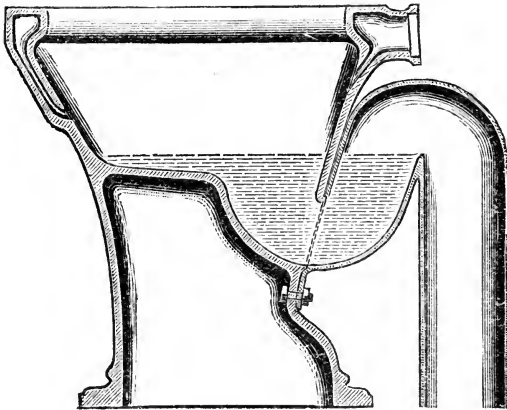

FIG. 181.—Betterment water-closet.

introduces some change into his special closet, and the plumber has to be in a position to know the worthy from the worthless.

We must consider and illustrate, however, the Dececo water-closet, which comes from America, where ventilation of soil-pipes is not so universally adopted or approved as with us.

It is undoubtedly as simple as any closet made, is trapped above ground, has no mechanism, has a deep water-receiver and trap for soil, has a flushing rim, and discharges by

syphonic action effectually, and can be used as a slop-sink or urinal safely. Care must be taken to secure a good safe connection below the trap with the soil-pipe.

The water in the basin itself, as in the wash-down form, is the trap of the apparatus, and is always in view. There is a second shallow dip underneath, which becomes a temporary trap when flush is actuated, compressing the air between the permanent and temporary water-traps, and starting powerful syphonic action to empty the basin.

The flush must be so arranged as to fill up basin and trap after the syphonic action has ended, else the foul air would have free way to enter the house, as the temporary under trap always unseals and remains unsealed after the flush ceases. No air-vent can be placed on the outgo between the two traps, as it would prevent the compression of air necessary for starting syphonic action.

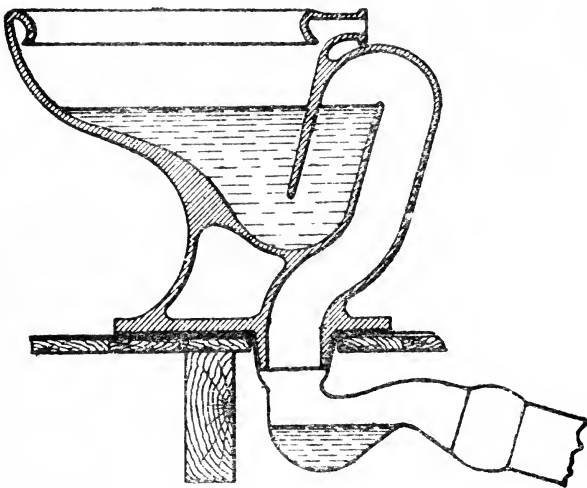

FIG. 182.—The Dececo closet ready for use. The bowl and the short limb of the syphon are filled with water to the overflow level. The long limb of the syphon is open, and its air is in communication with the air of the soil-pipe.

Taking the various forms of apparatus in order, a very prominent place must be given to the valve closets, which many experienced plumbers and engineers consider the best form of apparatus for internal house use.

Valve closets have been improved, and altered, and disimproved by maker after maker. Every exhibition brings forth a new variety, the alterations of the valve and overflow arrangements being the most marked and numerous.

The main point about a valve closet is the valve, those having india-rubber seatings being more reliable than brass ground-in seatings. In selecting a good valve closet, it is usual to test the valve by pressing it down by hand pressure; if it opens under any ordinary pressure, the valve will not prove staunch in use. When the valve opens by

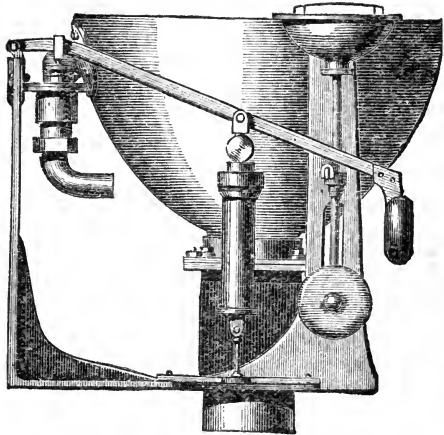

FIG. 183.—Ordinary valve water-closet.

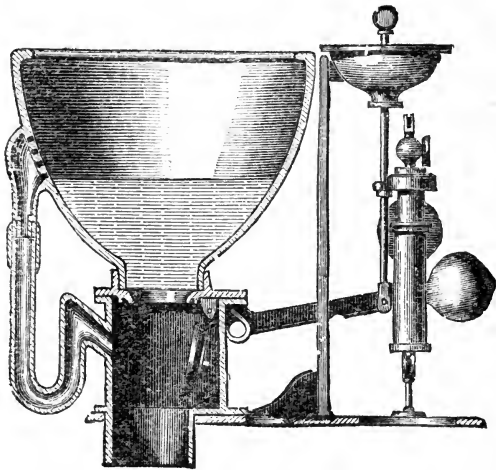

FIG. 184.—Ordinary valve water-closet. Section.

will not prove staunch in use. When the valve opens by

raising the handle, it should open sharply and fully, to allow the body of water and soil to pass down in an unbroken body into the trap below. The next point of importance is the arrangement of the overflow. It is important that the trapping of overflow should be very secure, and that the overflow should be maintained quite pure. In some closets the overflow is led into the valve-box immediately behind the

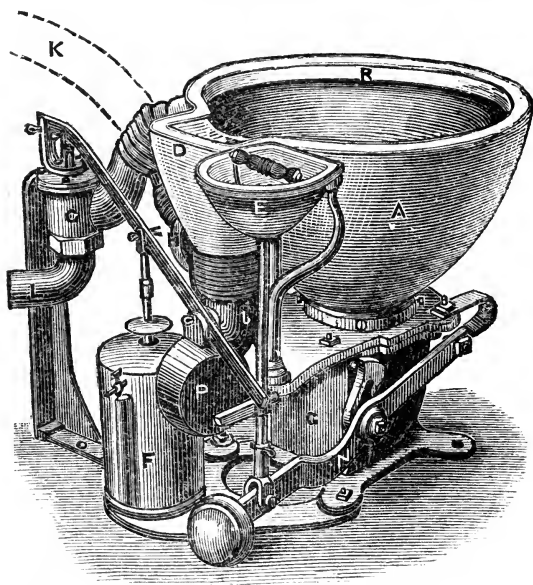

FIG. 185.—Improved valve water-closet.

valve, in some ill-arranged closets the valve opens so as to allow the soil in passing to foul the overflow, while in others the valve opens against the overflow, so as completely to protect it. Many makers commit the serious error of putting a shallow insufficient trap on the overflow, which is unsyphoned regularly at every flush, and is often left empty, allowing any foul air in the trap chamber to return. The overflow trap, wherever it discharges, should be deep and secure.



Some makers provide for a distinct discharge of the overflow into a rain-water or other clean water disconnected pipe outside the house wall; but this precaution is a very troublesome and costly one, and frequently fails in effect, by the rain-pipe becoming foul from the overflow discharges.

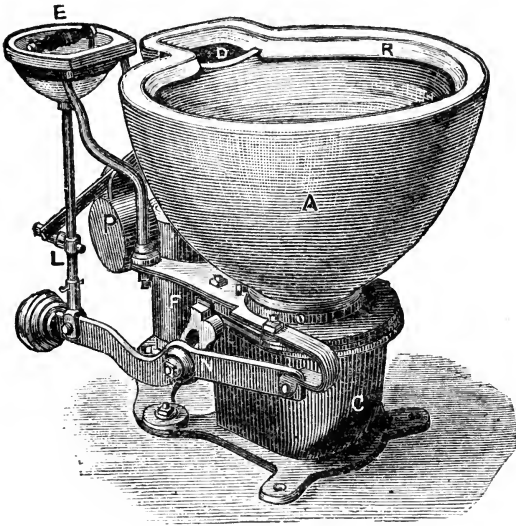

FIG. 186.—Improved valve water-closet.

Some makers take an air-vent pipe from the valve-box to ventilate the space confined between the valve, when closed, and the trap below. This precaution should be always taken. It is very good practice to join the basin overflow, well trapped, into this air-pipe, which acts as a vent to the overflow, and protects its trap from being unsyphoned.

Some makers use ball-valve traps on the overflows, but ball valves are additional complications on traps in any position. Some makers provide the entrance to overflow

very high up in basin, by forming basin with a recess, and they arrange the flushing rim so that at every flush a portion of water flows into and through the overflow direct, to cleanse it and keep the trap fully charged.

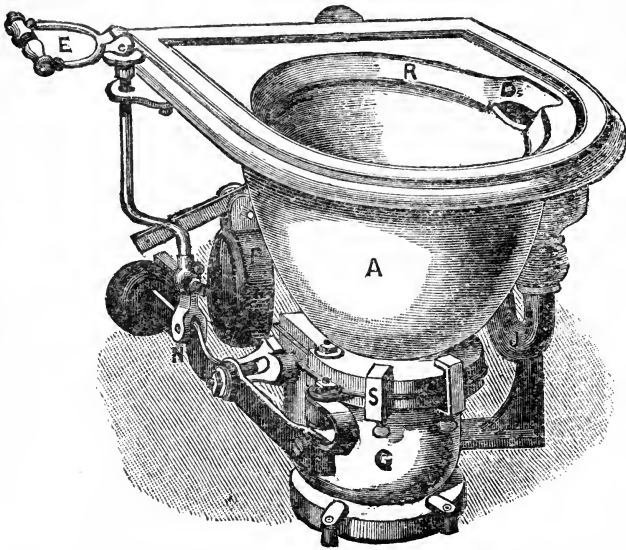

FIG. 187.—Improved pedestal valve water-closet, with white ware top.

The supplies to valve closets may be arranged in any of the ways already named.

The trap will be generally under the floor line, and must be well ventilated at outgo, so as to prevent unsyphoning by the volume of water descending full flush from the basin. Valve closets are now made with traps above the floor line, and accessible easily, but the connection of the trap with the soil-pipe cannot be so reliably made as when the trap is of lead soldered to the soil-pipe, as a fixture above or below the floor, independent of the closet, so that whenever the closet is removed for repair, the trap continues to exclude foul air from the house.

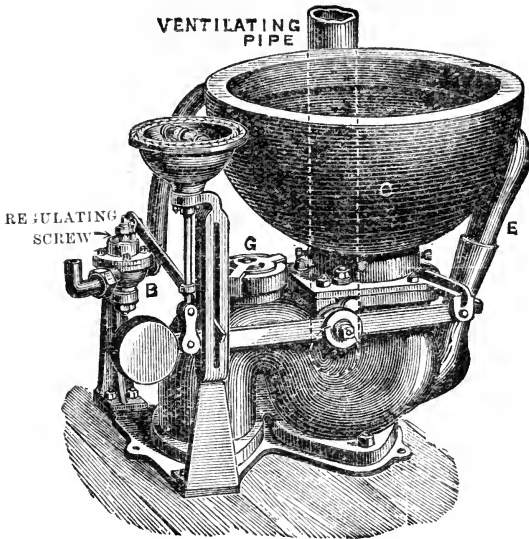

FIG. 188.—Improved valve closet, trapped above floor.

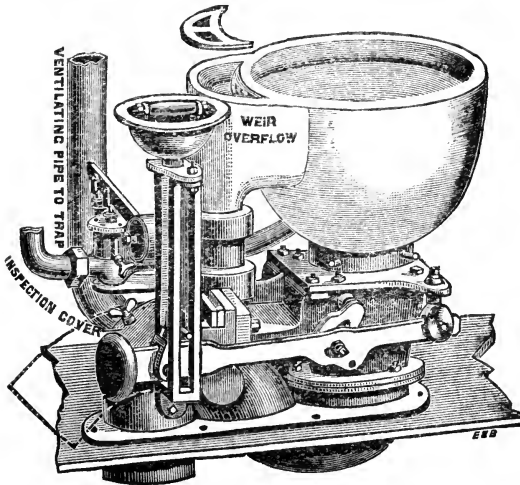

FIG. 189.—Improved valve water-closet, trapped above the floor.

Lead safe-trays with 1½-inch wastes to open air, with copper flap-valves, should be always fitted under valve closets in all good work.

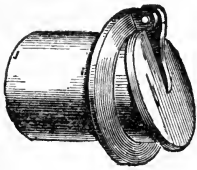

FIG. 190. — Copper flap-valve for safe-trays.

Corbel wash-down water-closets are now much adopted for hospital and asylum use; they are supported on solid fireclay corbels built into the wall, and they leave the floor space open and accessible for washing and sweeping. Closet and trap are formed in one piece, supported on the corbel free from the floor.

An illustration of this arrangement with plan and section fully explains the mode of fixing.

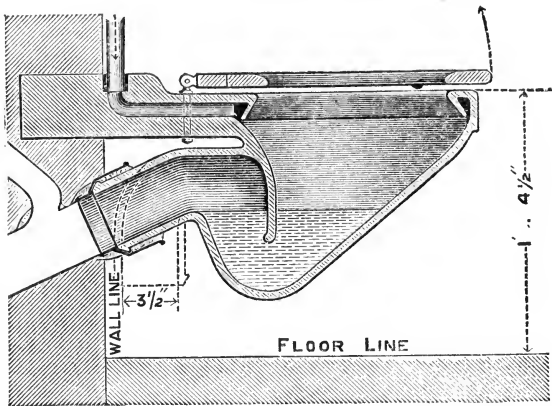

FIG. 191.—Section of corbel wash-down water-closet.

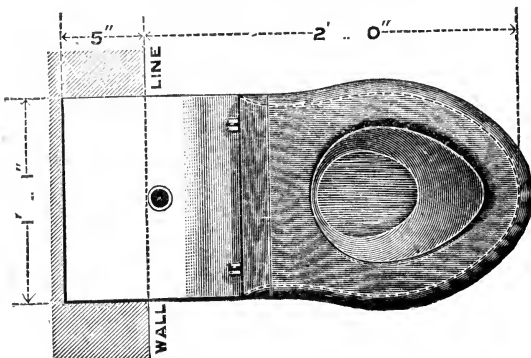

FIG. 192.—Plan of corbel wash-down water-closet.

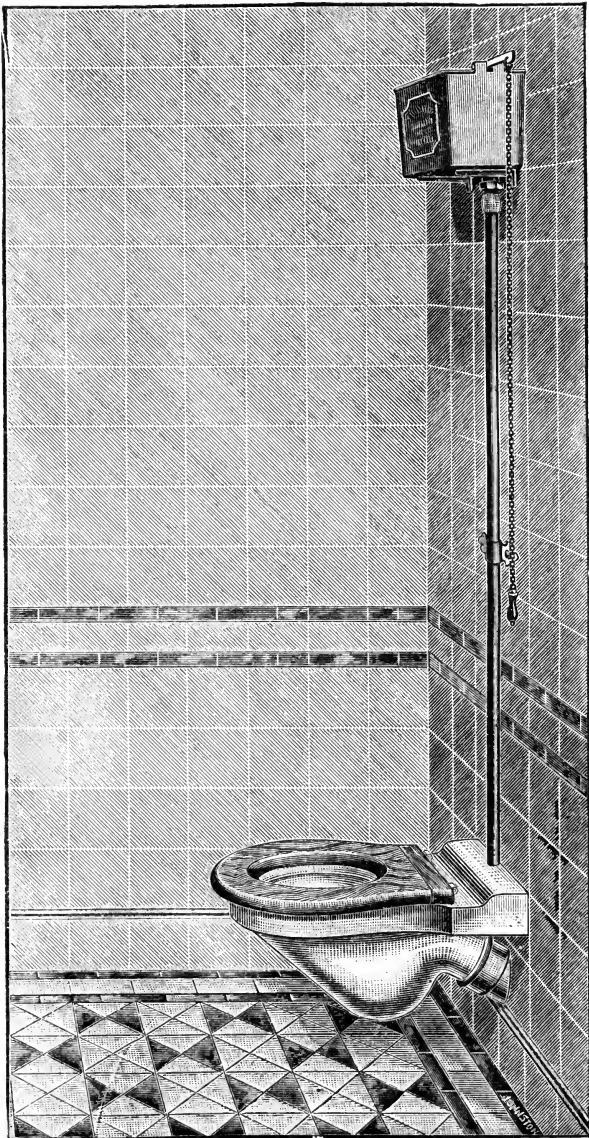

FIG. 193.—Corbel water-closet complete.

A neat, plain pedestal wash-down water-closet is illustrated on this page and opposite; it has the advantage of solid rest on the floor which some architects require, and are willing to give up the advantage of free cleaning space underneath in order to gain the appearance of stability given by the pedestal.

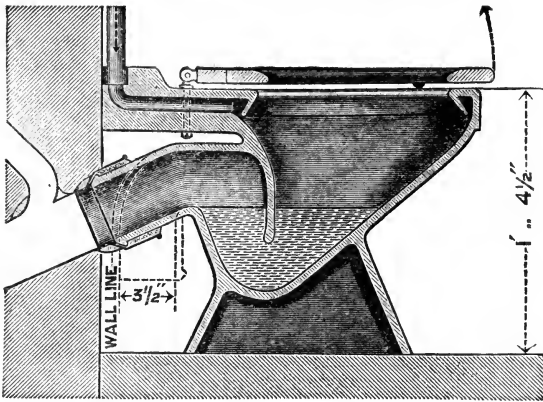

FIG. 194.—Section of neat, plain pedestal wash-down water-closet.

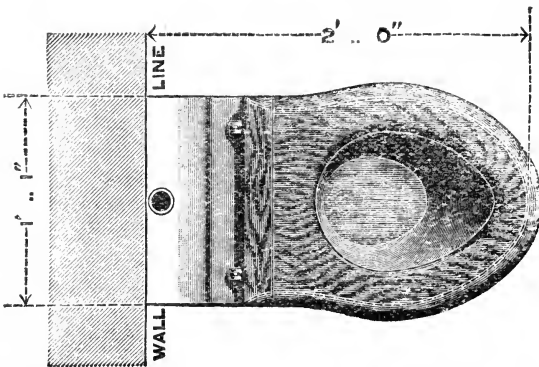

FIG. 195.—Plan of neat, plain pedestal wash-down water-closet.

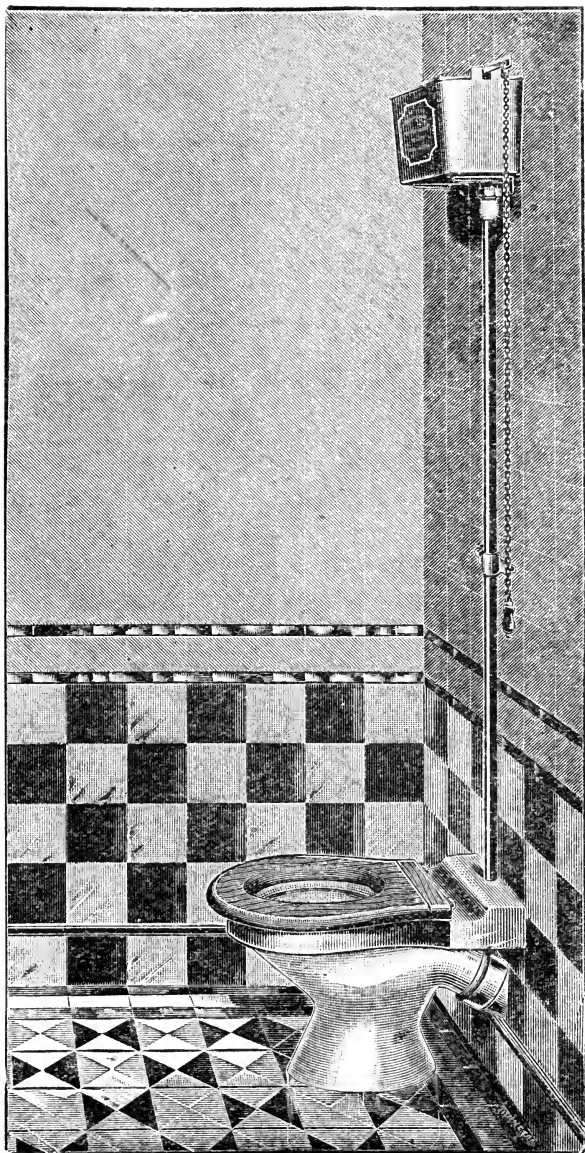

FIG. 196.—Neat, plain pedestal wash-down water-closet.

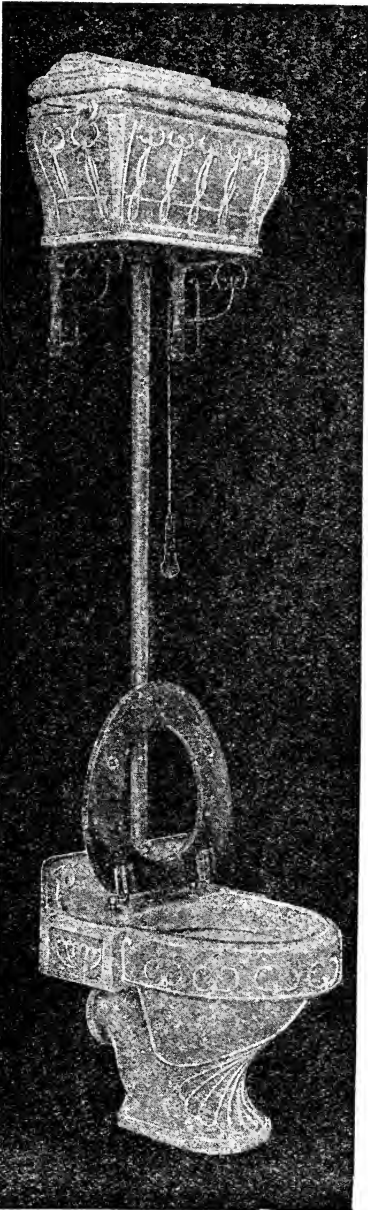

FIG. 197.—The Epic wash-down water-closet.

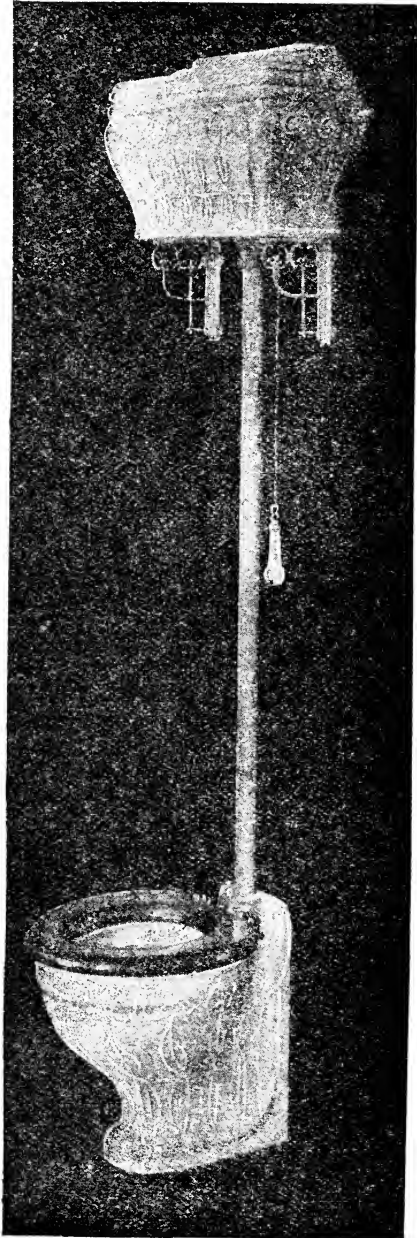

FIG. 198.—The Lota design wash-down water-closet.



We give these recent designs of Adams' closets, as they deserve special illustration, showing the advances made in this class of fixture.

This closet is designed for hospital use, and can be obtained in cane colour or in white at moderate prices. We illustrate it as being an advance in design, combining simplicity and good appearance.

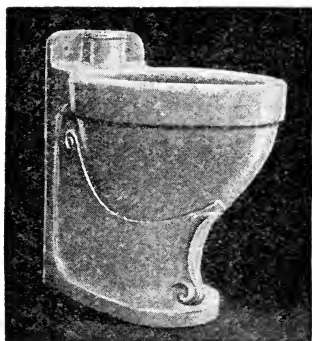

FIG. 199.—Hospital closet.

This is a very perfect form of latrine. The single pans, separate for each user, combined with the ready discharge of matter and accommodation for numbers when space is

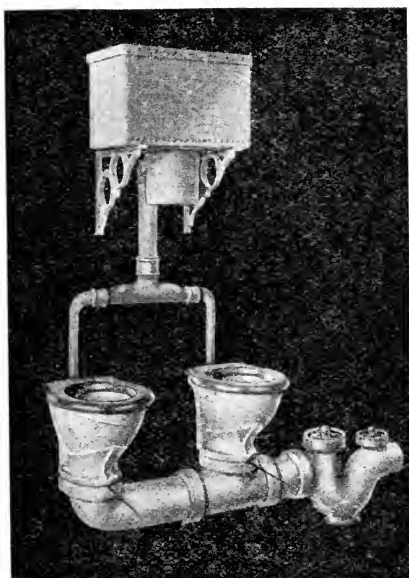

FIG. 200.—Adams' improved patent latrine.

limited, are sanitary advantages combined with absence of space for accumulation of paper, etc., the backs being flat and tight to wall.

Where it is desired to use separate single closets and yet to flush all in the group simultaneously, these closets will commend themselves, and are illustrated here.

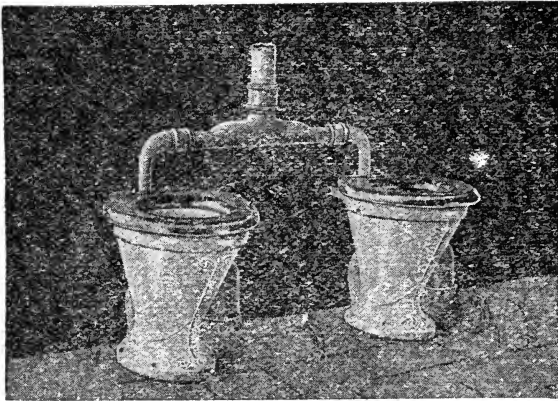

FIG. 201.—Adams' insular multiple closet.

Latrines or ranges of closets for schools should consist of a series of separate closets. Trough closets, where several persons use one trough, though in distinct compartments, are not safe in a medical point of view, as illnesses may thus be communicated.

The glazed fire-clay trough latrines illustrated here are suitable for factories, mills, and barracks. It is sought to render them specially cleanly by employing buff glazed fire-clay divisions, secured by cast-iron pillars, top ramps, and bottom sills. The divisions are not carried down to the floor, so that every part can be easily cleansed. Supply valve and discharge valve are provided at end of range, with locking cover under control of attendant.

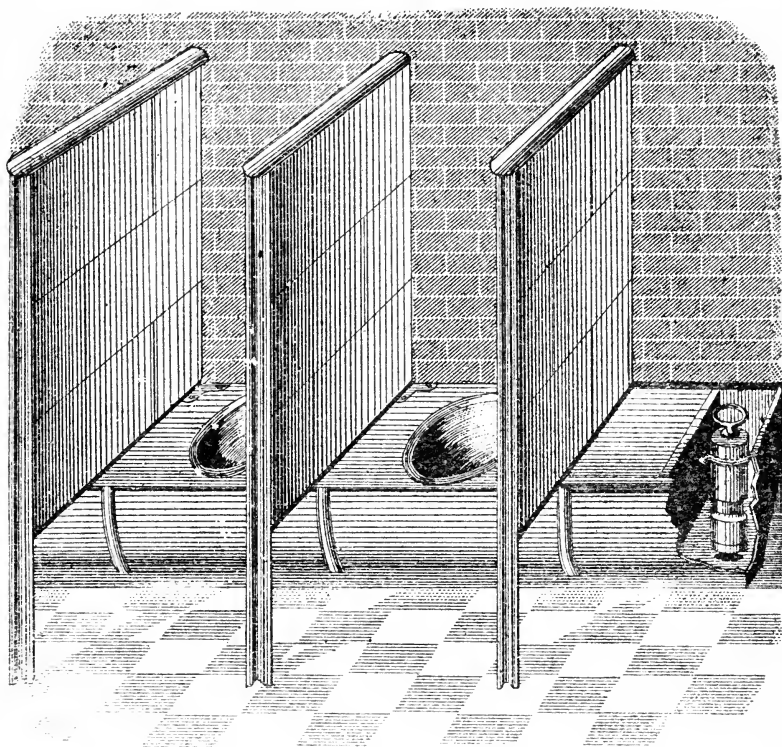

FIG. 202.

The best latrine form is that of a series of enamelled or glazed earthenware basins, made of globular form to prevent sides being fouled, all jointed by Portland cement into one range of earthenware pipe, having a plug valve at one end over a trap in lock-up press under a keeper's care. The water is arranged to stand about a foot deep in the basins to receive the soil, etc., and three or four times a day the keeper raises the valve and flushes out the closets, which he fills up immediately with a fresh supply of pure water, ready for use. The ventilation of the closet compartments should be very complete; the doors are

generally hung six inches above the floor, with ample openings above.

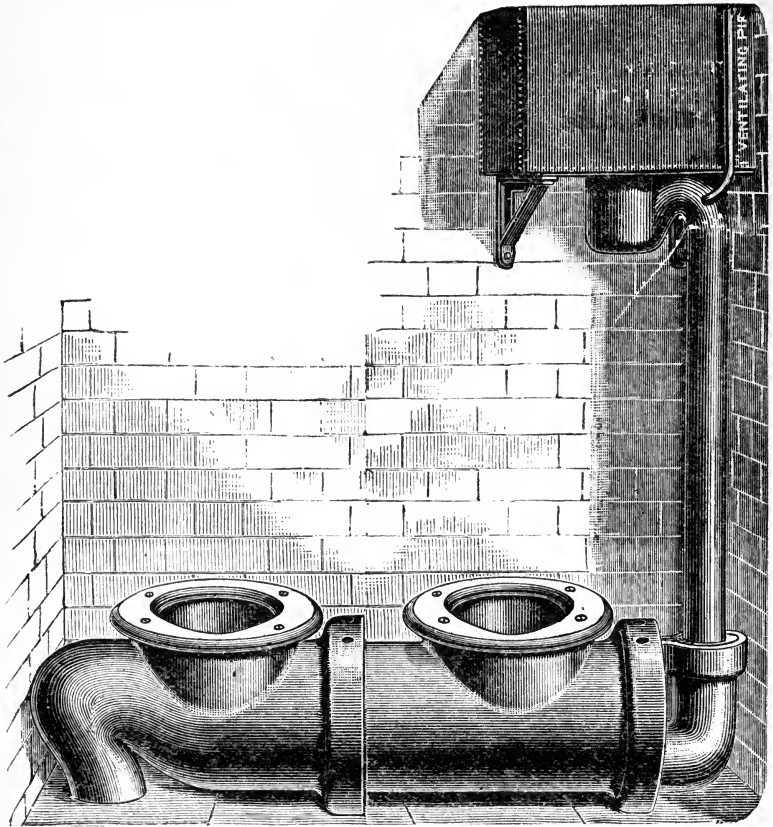

FIG. 203.

The same form of closet will be found suitable for third-class accommodation at railway stations, and for public necessaries. Experience has shown that to maintain such places passably decent a caretaker must be always in charge, and he must flush out the closets at stated times, or whenever such flushing becomes necessary. Water-closets in

public places, for the use of people unaccustomed to such appliances in their houses, will never be flushed properly

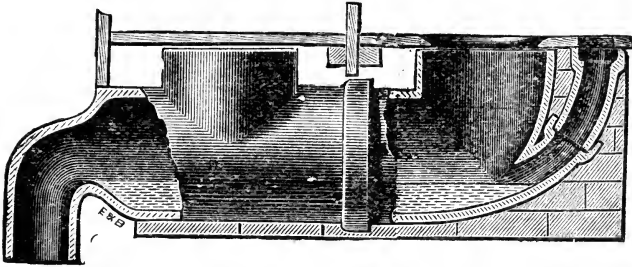

FIG. 204.—Section of earthenware latrine, with retaining weir, to be used with automatic flush tank.

by those who use them, so that it is useless to provide arrangements for that purpose.

Urinals are difficult appliances to turn out so as to fulfil the requirements laid down for us at the commencement of this chapter, but as they are essential in certain places we

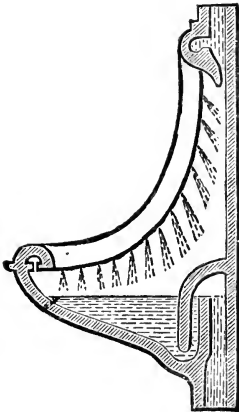

FIG. 205.—Improved flushing flat-back urinal.

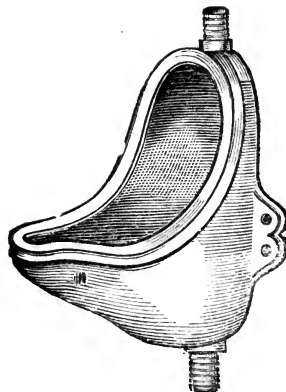

FIG. 206.—Flat-back cradle urinal.

must be prepared to supply them, and to fix them as they ought to be.

In private houses they should not be fixed at all, unless in a perfectly suitable position, where an abundant supply of water can be given.

The urinal itself should be small, neat, free from ornament, and of pure white porcelain or stoneware. Plenty of good simple forms are made by all sanitary potters, and there is no occasion to go to the Patent Office. The height from floor to tap of the receiver in front may best be settled at two feet.

The waste-pipe may be of pottery ware or lead, and should deliver out in the open air, in a safety disconnecting receiver, keeping the waste-pipe as short and free from bends as possible. The waste, passing out through wall directly under urinal, or down direct to a 4-inch disconnected drain in floor, with a trap and grating for floor washings, can be made to work in a satisfactory manner.

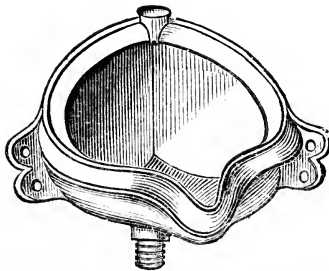

FIG. 207.—Corner urinal, lipped front.

The water may be supplied, where permitted, in a continuous dribble through the top, or in intermittent flushes from a syphon automatic zinc or copper tank, holding one gallon, which any plumber can make and fix. The long leg of the syphon should dip about three-eighths of an inch in a

small trap under the cistern, and a mere dribble will start it when overflowing into flushing syphonic action.

White polished marble, five feet over floor, or glazed tiling of some light colour, is the best wall lining behind

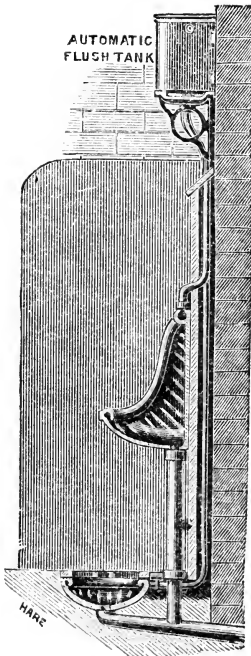

FIG. 208.

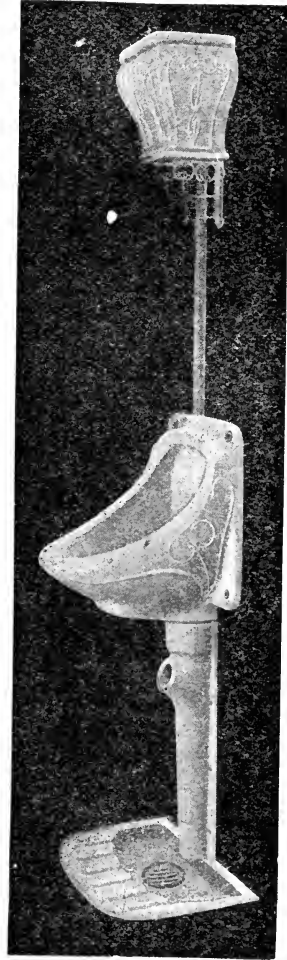

FIG. 209.—Adams' new design of urinal in titanic ware.

the urinal; the floor being carefully tiled with some hard impervious tiling near the urinal, if the whole room floor be not tiled. No grating should be necessary in the floor, for the housemaid should daily wash the tiles, so as not to slop water about. Iron treadle arrangements for flushing urinals

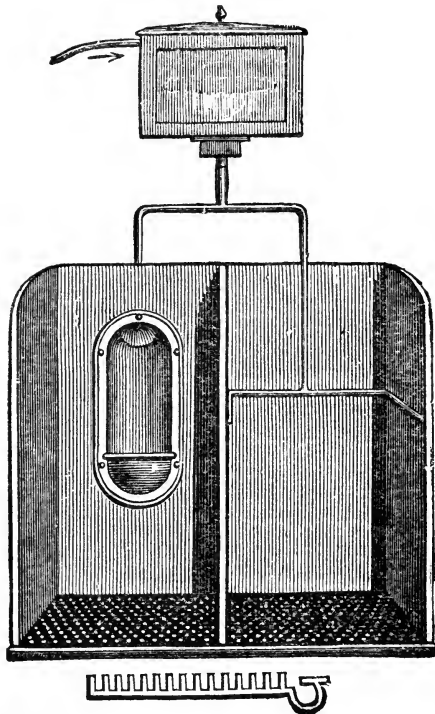

FIG. 210.—Cradle and plain slate slab urinals.

generally become very offensive, owing to the difficulty of washing them effectually. They are not desirable in any position; much simpler, cleaner means of flushing exist. In fact, there should be no place on the floor, or about a urinal, that cannot be easily washed clean with soap and water. Water flushes should wash all the interior of urinal thoroughly.



In hotels, clubs, restaurants, and theatres greater care is needed to arrange urinals, where under cover in the building, so that no unpleasant odours may arise. Enamelled slate water-troughs, with polished brass gratings over them, sunk in the tiled floor under the ranges of urinals, and kept full of flowing water from the wastes of each urinal, through which the pure flushing water descends, have been adopted

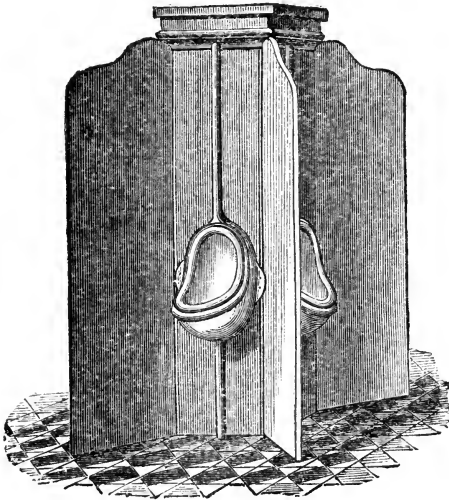

FIG. 211.—Central standard urinals.

successfully, but a good flow of water is needed to keep the trough pure. Here the floors of the chambers are invariably tiled all over, and can be washed into the running trough daily; perhaps the tiling may be given a slight fall towards the trough for this purpose. The best plan, however, will be to lay the unbroken, impervious tiled floor under the urinals, and to keep this clean and pure by daily washings.

The walls behind urinals should be covered with glazed tiles or polished marble, 5 feet or 5 ft. 6 in. high. The

divisions are best made of white polished marble or enamelled slate, one and a quarter inch thick; but they should be cut away at the bottom, with a wide curve, leaving about six inches next the wall to rest on the ground and support the weight of the division, while the portion cut away leaves free space for washing the flooring tiles,

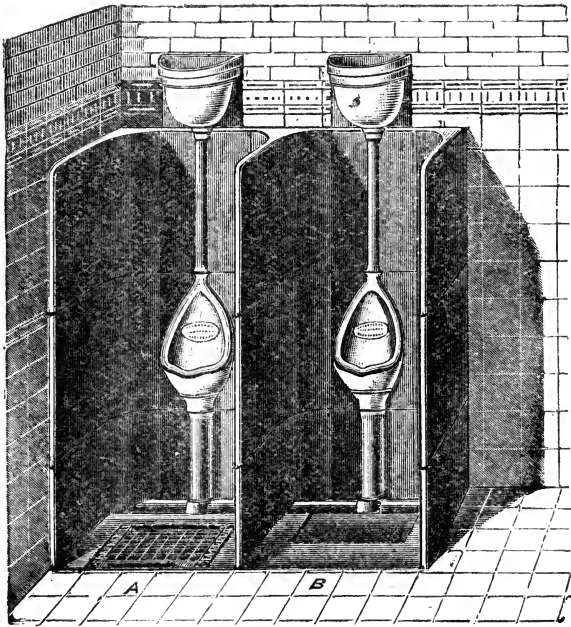

FIG. 212.—Fire-clay urinal.

and avoids corners for dirt to cling to. This plan is much better than to carry the divisions down the full width to the floor, or to cut them short, and rest them on iron brackets from the wall.

Flat-back or recessed-back urinals are better than corner urinals, each urinal having a marble screen at each side. The width of the screens apart may be from two feet to two

and a half feet, and the screen projection from wall about one and a half to two feet, and the height five and a half feet over floor tiles.

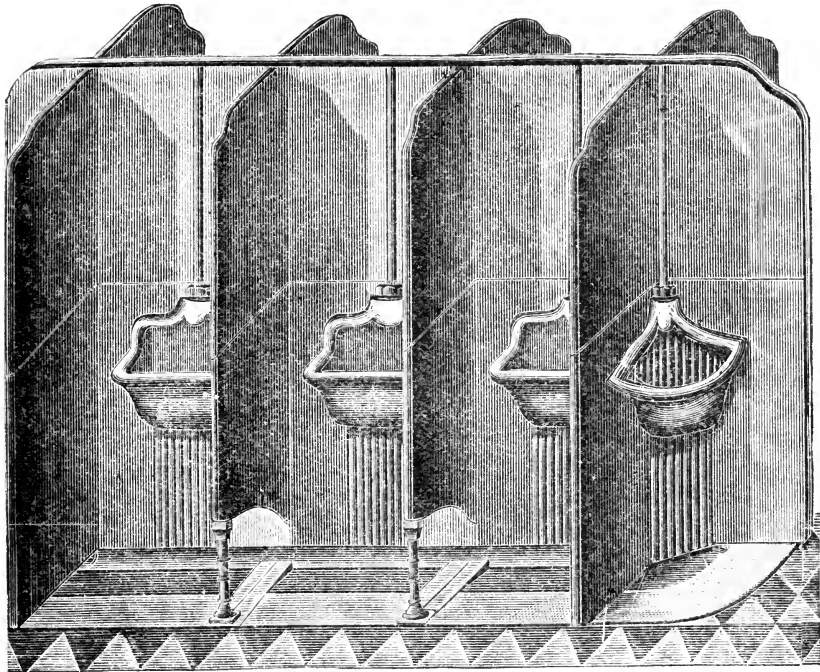

FIG. 213.—Fire-clay central standard urinal.

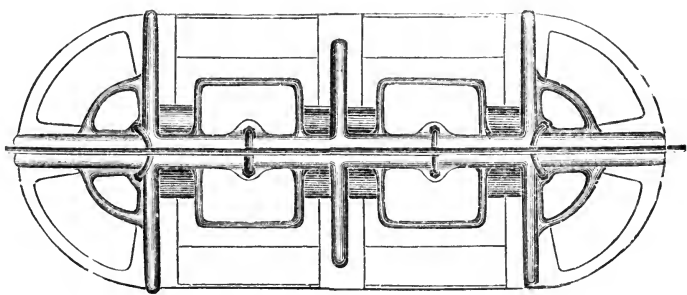

FIG. 214.—Plan of fire-clay central standard urinal.

The plumber is frequently entrusted with the whole arrangement, including marble work and tiling.

Glazed fire-clay urinals have been introduced for public places, to obviate objections to polished marble and enamelled slate divisions. The urinal basins are made with and form part of the back, and so metal pipes are dispensed with. The divisions and back are built up on a fire-clay sole, with channel extending to front of division, with or without grating. Automatic cisterns in fire-clay give periodic

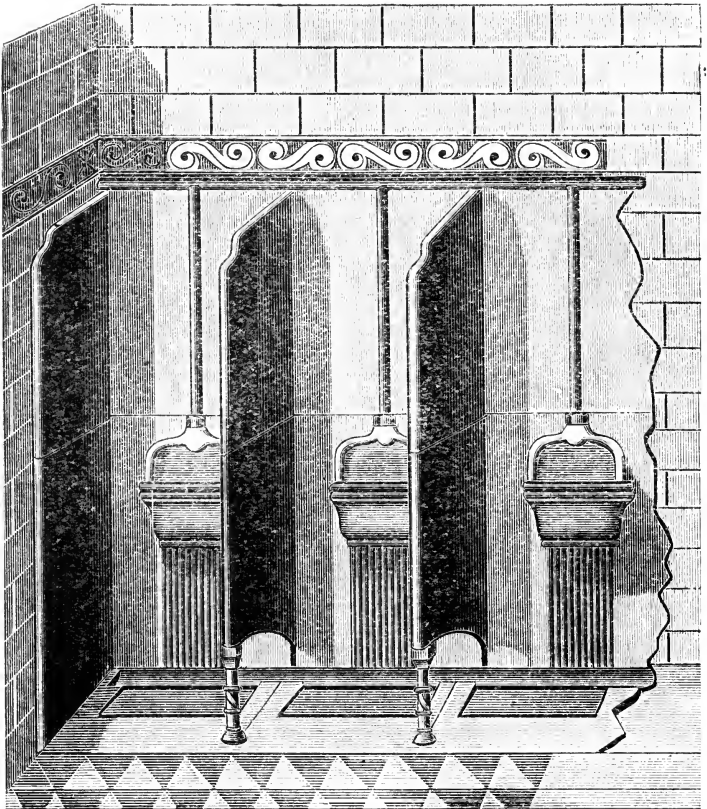

FIG. 215.—Fire-clay wall range of urinals.

flushes, or pipes may be arranged for constant flush. There is not much plumber's work in connection with this arrangement, but it is necessary that plumbers should see how other materials are superseding lead and metal.

In the urinals illustrated above (Figs. 213-215), the back and divisions are made in buff glazed or white enamelled fire-clay, with moulded flushing-rim basins and fluted back combined in one piece with the lower back slab very solidly. These are fixed on glazed fire-clay slabs and draining channels, and are flushed continuously or by automatic discharges at intervals.

This arrangement may be commended as simple, sanitary, and durable. There are no joints in the stalls, as the back

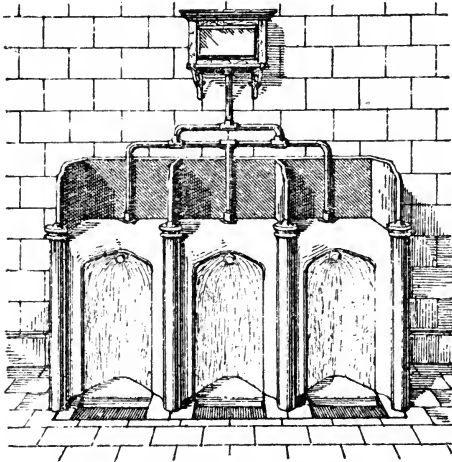

FIG. 216.—Improved urinal range.

is in one solid piece of smooth enamelled fire-clay. It is fitted with nickel-plated spreader and flushing pipes, there are no movable foot-gratings, and all is flushed by automatic flushing cistern.

Housemaids' slop-sinks are generally found on examination

to be a greater source of danger to houses than the water-closets. The same fear of mischief arising from them does not seem to be entertained, and, as they are only used by a servant, no attention is paid to their structure or condition.

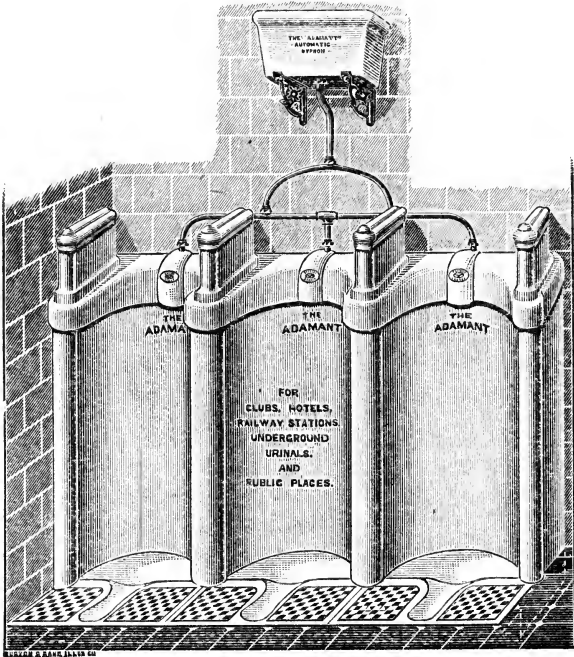

FIG. 217.—Improved white glazed urinal range.

They are often fixed next to a bedroom, and for all insanitary purposes are as dangerous to the occupant of the bedroom as if they were fixed in the chamber itself. The writer has just completed the inspection of a nobleman's mansion where this evil exists, the sink being within three feet of the bed in a principal bedroom.

The points of special danger or safety are—

1. The waste-pipe and its connection.

2. The trap and its ventilation.
3. The construction and material.
4. The water supply.

In a well-arranged slop-sink the waste-pipe should be of 10-lb. lead at least, to resist action of hot and cold water and slops, and the diameter should be three inches. It may best be carried independently out to open air with a quick fall, and into a full-bore ventilated 3-inch down pipe to the ground, where a safety disconnecting receiver should be ready to take the waste on to the drain. The waste may in certain cases be connected into a water-closet soil-pipe, if this connection be convenient, the soil-pipe well arranged and ventilated, and a 2-inch vent-pipe be taken from the outgo of the slop-sink trap to a proper position.

The trap should be of drawn or cast lead, three inches in diameter, with a 3-inch down, and a brass cleaning-screw fixed under the water-line, and well opened out into a deep cone to receive the sink basin. The 2-inch vent-pipe from outgo already mentioned is a sanitary necessity to prevent unsyphoning of the trap. A lead safe-tray should be fixed under the slop-sink, of 5-lb. sheet lead turned up six inches all round, with a 1½-inch or 2-inch waste-pipe direct through wall to open air, having a copper flap-valve on end. On no account should this pipe join any other pipe. The tray should be arranged to receive any overflow in event of trap choking, or careless emptying of slops.

The sink may be of a conical form, of glazed pottery ware or enamelled iron, or it may be of the more approved form, nearly square, but having rounded corners and sloping bottom. The top may be formed of 8-lb. or 9-lb. lead, where cans rest, with lead flashings of 6-lb. lead well arranged, or, better still, with enamelled earthenware top and sides, which are formed specially for this purpose in

many potteries, and are much purer and neater than lead can be. Hard-wood capping is then needful for the edges.



FIG. 218.—Conical slop-sink.



FIG. 219.—Basin slop-sink.

There should never be any draw-off taps, hot or cold, for filling cans directly over a slop-sink, because a splash of foul slops may pollute one of such taps and cause serious illness in the household in the event of careless servants filling the carafes in bedrooms from the cans.

There should, however, be a flushing arrangement for turning on water so as to cleanse the slop-sink and traps after slops have been passed down. This should be so arranged that servants could not fill cans thereat. A hinged wooden or brass grating is sometimes fixed over the conical sink to rest cans on, but as this implies having the draw-off tap over the sink also, the arrangement should be condemned.

An open cast-brass grating, capable of being unscrewed by a handy man, should be fixed at bottom of sink to intercept cloths, brushes, soaps, etc., but should possess an open area equal to the area of the trap and waste-pipe to ensure a full flush.



Housemaids' troughs should always be fixed beside the slop-sinks and on a higher level, so that the waste and over-

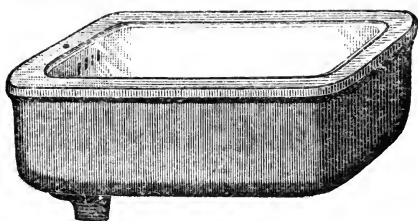

FIG. 220.—Enamelled earthenware trough.

flow pipes may deliver over the top of the slop-sink, but not direct into the waste or soil-pipe.

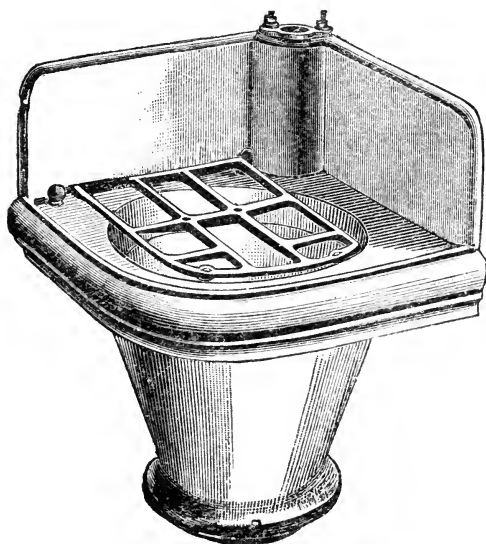

FIG. 221.—Improved earthenware slop-sink, with can-rest hinged over.

The trough is best made of white enamelled earthenware about 2 ft. 6 in. long and 1 ft. 2 in. wide, and large enough for a large water-can to stand in it under the water taps, the waste-pipe of 2-inch lead, with a 2-inch lead trap and

brass cleaning screw on same, and a brass plug and washer in the trough, so that trough may be filled and emptied into the slop-sink to flush it out well. Proper flashings should be arranged against the wall to prevent damp from splashing,

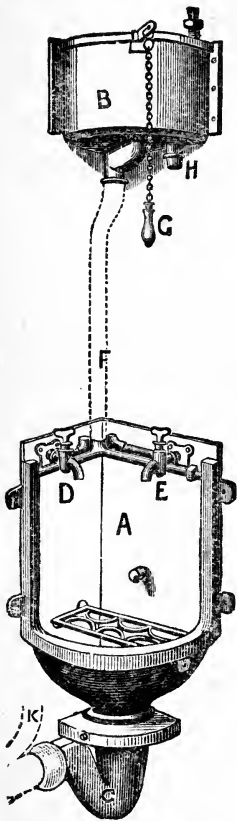

FIG. 222.—Angle slop-sink.

ing, and the hot and cold taps for bedroom service should be fixed over this trough high enough to admit cans to stand under, and so placed that the splash from the emptying of slops into the conical sink cannot possibly foul them.

Many other arrangements of housemaids' slop-sinks have been devised; indeed, it is hardly possible to bestow too much care and attention on this class of sanitary appliance. In some houses they are to be found on every floor, in all large hotels they must be numerous, while servants exhibit little care and cleanliness in using them.

The arrangement of slop-sink here illustrated is designed for fitting up in a corner of a housemaid's closet where space is limited. The cistern B flushes the sink thoroughly by syphonic action, when handle G is pulled; D and E are hot and cold valves, high enough to admit cans under to stand on the hinged shelf for filling. The sink can

be formed of enamelled iron, or, if preferred, enamelled earthenware. The trap c, as already explained, should always be ventilated by the vent-pipe k.

This improved arrangement (Fig. 223) is best carried out by using a white enamelled earthenware trough, A,

and an enamelled cast-iron slop-sink, B, with side flushing arrangement, D, so that the slop-sink will be thoroughly flushed out by filling the trough and pulling out its waste plug. The skirting E may be formed of marble or glazed tiles, and the hot and cold taps F and G are placed where no splash from slops can foul them. The arrangement I, in corner of trough, shows an extra large overflow to waste.

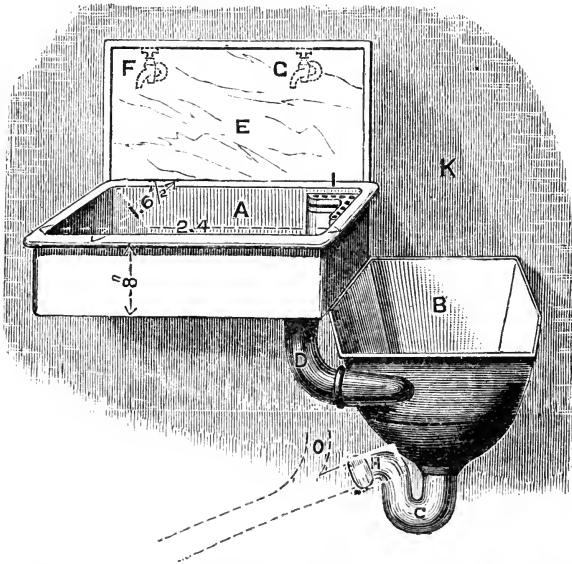

FIG. 223.—Design for sanitary combination slop-sink and trough.

The trap C may be of heavy cast lead, and must be protected from danger of syphonage by the large vent-pipe O, carried to proper position as before explained. In adopting any new plans, always ascertain whether patent rights are in force. When these are in force, patentees must be applied to for royalty before any patent is adopted; and generally patented arrangements can be purchased cheaper and better from patentees direct.

The arrangements here illustrated are well suited for the purpose. They are formed of enamelled cast iron, with galvanized-iron or lead traps, and ventilating sockets on the outgo of the traps. The flushing of the basin is accomplished by means of an inch stop-cock, and the water requisite for

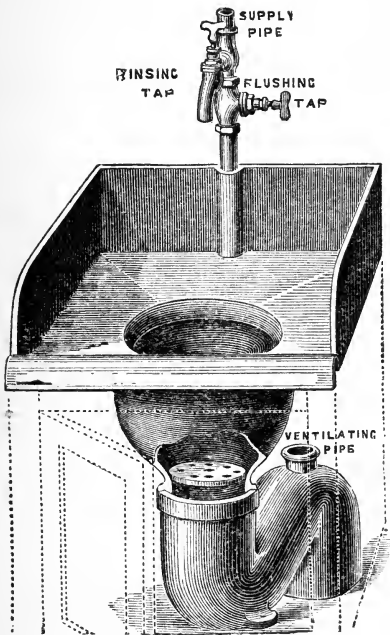

FIG. 224.—Slop-sink for recess or for wall space.

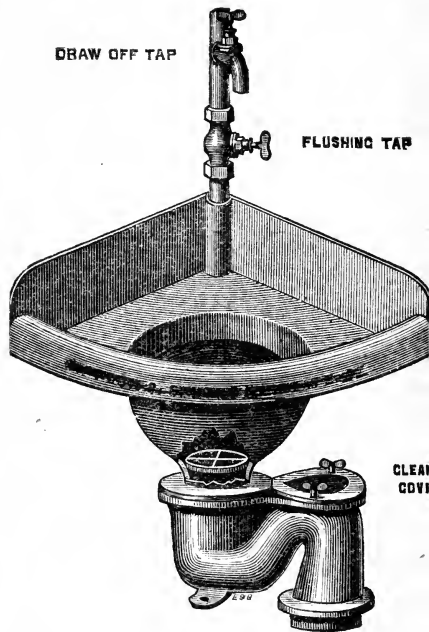

FIG. 225.—Slop-sink for cover.

washing out the buckets and utensils is drawn from the bib tap. This tap should be reserved for cleansing purposes, and should not be used in filling bedroom water-cans.

No water for drinking purposes should be drawn from any tap in such a position. It is an open question whether any draw-off tap should be allowed over any slop-sink. It is certainly safer to fix them over a separate trough in the

housemaid's closet, where there is no risk of splashings from slops soiling the draw-off taps. The galvanized-iron traps are usually fitted with air-tight cleaning covers, screwed down.

This illustration is of a very good form of household slop-

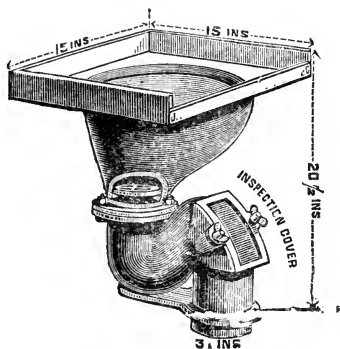

FIG. 226.—Household slop-sink.

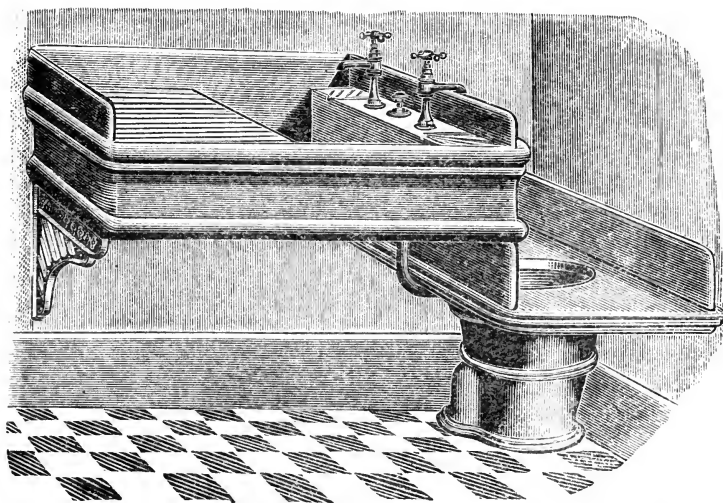

FIG. 227.—Design for a sanitary combination slop-sink and trough with drainer, as fitted complete, requiring no enclosure.

sink, with enamelled-iron basin and trap for a 3-inch waste-pipe. The trap has a cleaning cover, and a brass grating is fixed to exclude solids and cloths. Wooden drainers and casings are usually fitted to these sinks, and flushing arrangements are essential. Lead safe-trays on the floor should be laid under each slop-sink, with a pipe carried to open air, fitted at the end with a copper or brass flap-valve to exclude back inlets of cold air.

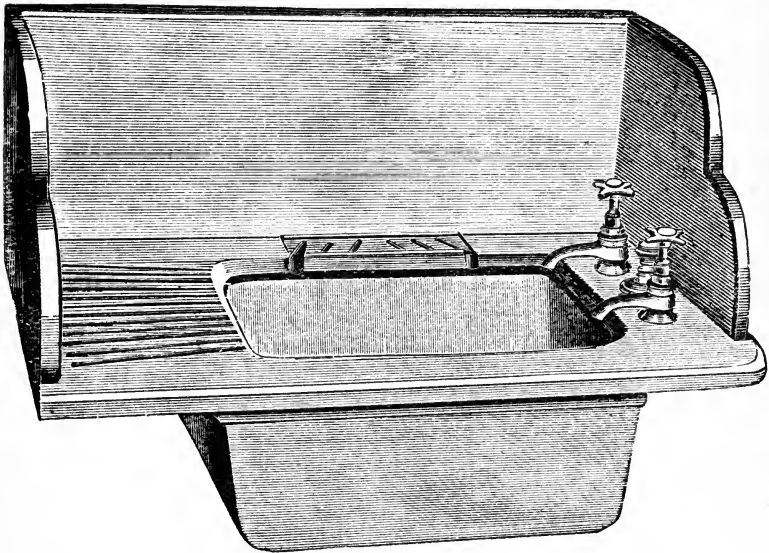

FIG. 228. —Improved housemaid's trough.

This form of trough may be made with grooved, polished, and oiled slate top and deep skirting, hot and cold taps, and lift-up waste. The trough itself may be white enamelled fire-clay.

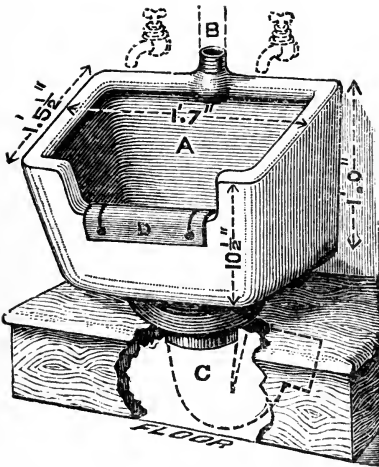

FIG. 229.—Improved white earthenware flushing rim slop-sink, suitable for hospitals, fitted with india-rubber pads to prevent chipping or breakage.

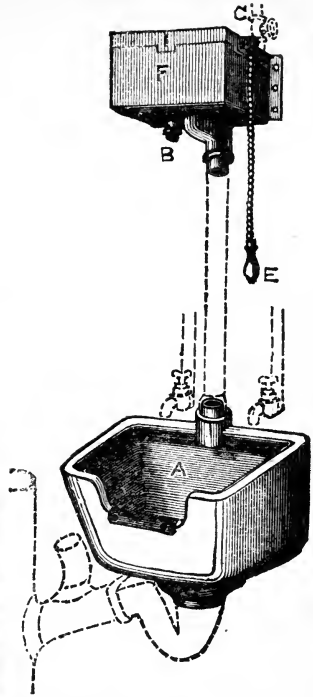

FIG. 230.—Illustration of method of fitting up slop-sink, with trap, flushing cistern, and supply. ]

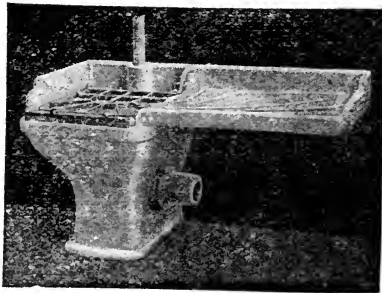

FIG. 231.—Model glazed ware slop-sink suitable for hospital service.

Fig. 232 shows a very good arrangement of draw-off sink and water-shoot slop-sink.

The sinks are glazed white fire-clay, and have a lip overflow which cannot choke or become foul.

The overflow discharges safely into the slop-sink.

The upper washing sink is fitted with brass plug and washer, with lead waste pipe into the slop-sink.

The water-shoot slop-sink is provided with a flushing rim. The method of trapping and of flushing supply as usual.

In fitting up hospitals and other institutions, it is necessary to provide very effective means for cleansing bed-pans and for disposing of slop water.

Fig. 233 shows an excellent arrangement, and answers the purpose well.

It consists of a special strong fire-clay sink white enamelled inside and buff out, resting on iron brackets built in the wall; it has a flushing rim and special flushing arrangement actuated by hand or foot, which flushes out the bed-pans thoroughly. The trapping and the cistern arrangement are shown in the illustrations, and fully explain the mode of fixing and of usage.

The floor is left clear for washing and sweeping.

Figs. 236 and 237 show another modern arrangement of sink for hospital use, with lead trap and out-go ventilation, flushing arrangement washing the interior of sink, and special flush for attaching bed-pans and washing out same thoroughly without danger of splashing.





FIG. 232.—Draw-off trough and water-shoot slop-sink.

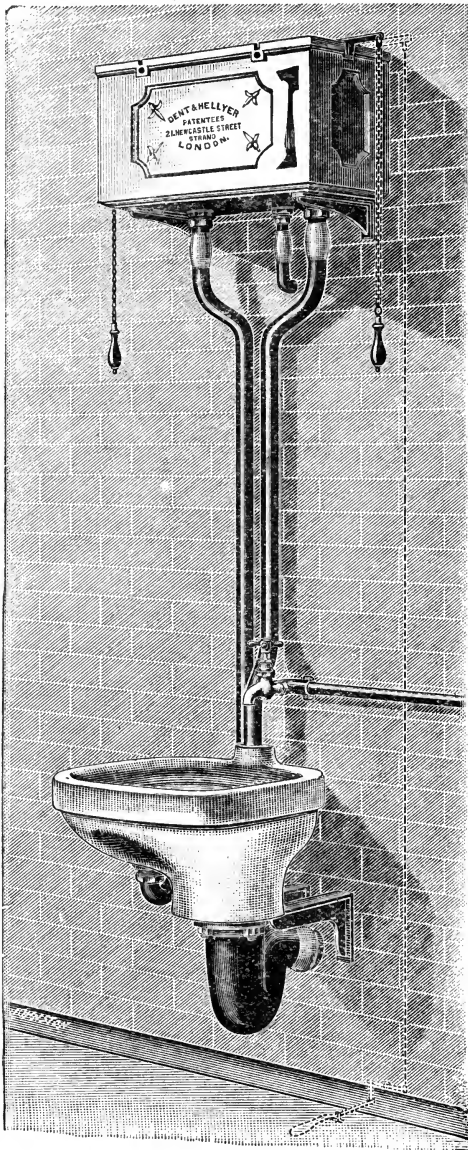

FIG. 233.—Hospital bed-pan sink.

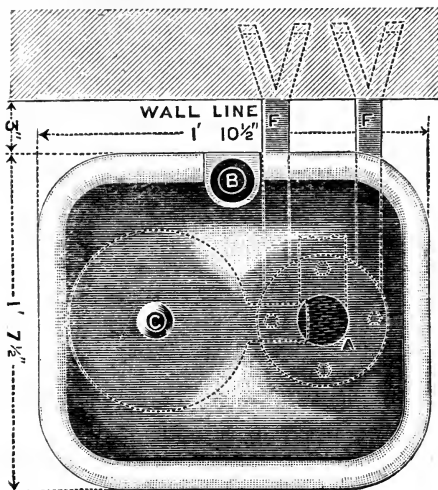

FIG. 234.—Plan of hospital bed-pan sink.

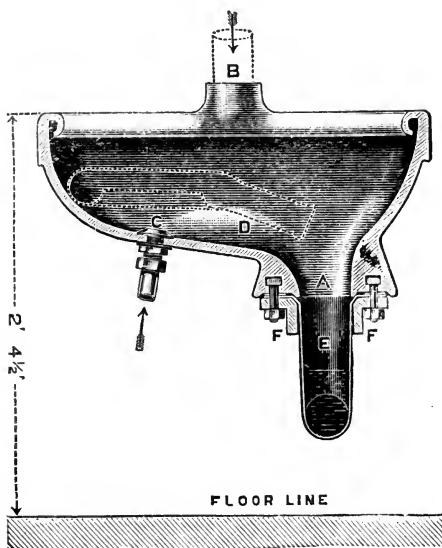

FIG. 235.—Section of hospital bed-pan sink.

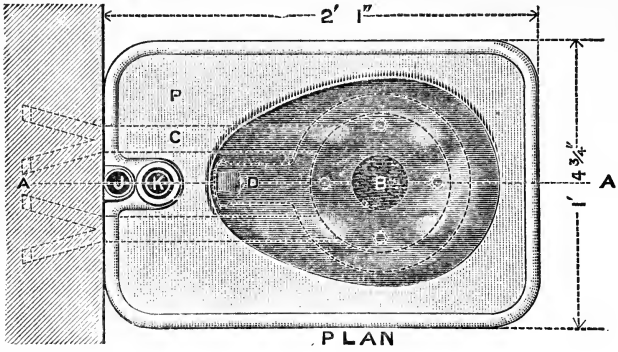

FIG. 236.

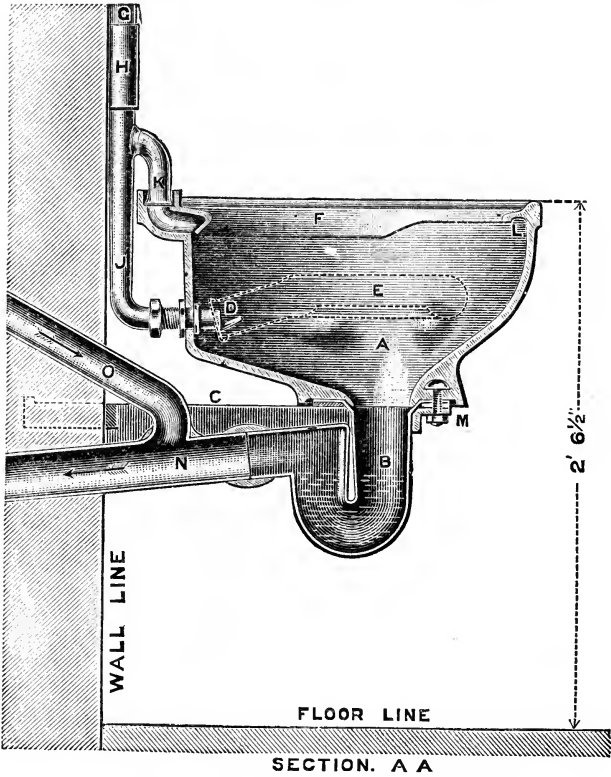

FIG. 237.—Hospital sink with bed-pan washer.

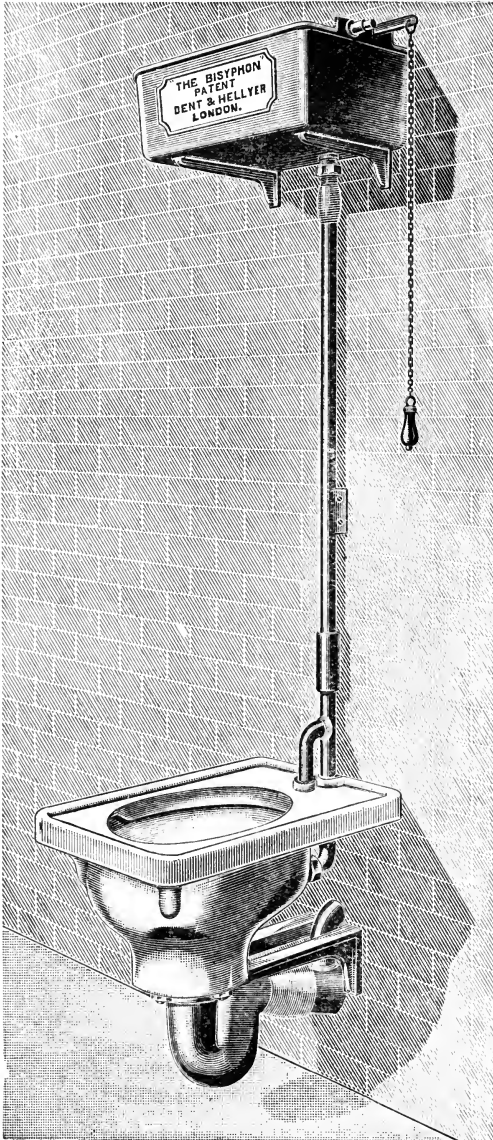

FIG. 238.—Hospital sink with bed-pan washer. Section and plan shown on opposite page.

Pantry troughs and scullery troughs should never join a drain direct; they should either discharge, as in Figs. 239 and 240, in open air, or over the trap of some well-planned disconnecting receiver-trap in open air. Overflows should always be provided.

Tin or lead-lined troughs will be preferred over earthen-

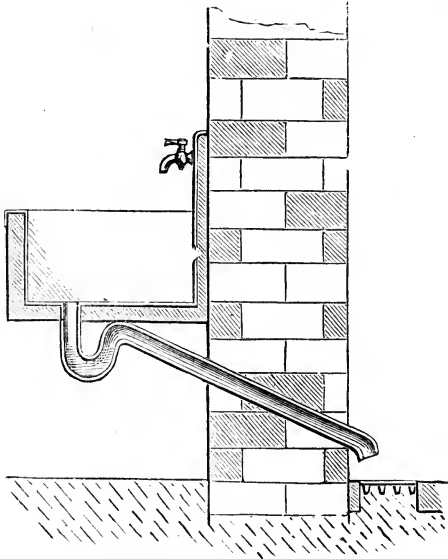

FIG. 239.—Lead-lined trough.

ware or cast iron, to save breakage, wherever glass and china are to be washed up.

The lead used is generally too thin—7-lb. and 8-lb. lead being specified where 10-lb. sides and 14-lb. bottoms would be necessary.

Avoid therefore, first, the use of light lead for lining.

Avoid having sharp-angled corners, but get a hollow filling fitted in all the angles, thus rounding them off and giving the lead some room for expansion and contraction

movement, else the linings will soon buckle up in ridges and wear away.

When the lead is dressed over the top of the trough it should be covered by a hard-wood capping to preserve the lead from cutting.

Avoid the risk of overflow by providing in all troughs

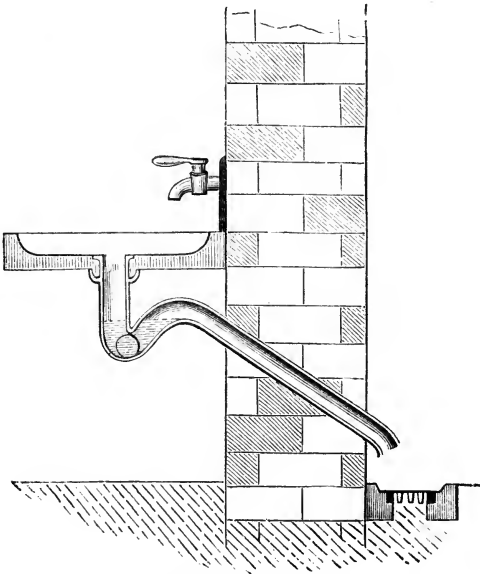

FIG. 240.—Scullery vegetable trough.

abundant escape for any water that can enter them, and avoid any risk of foul air entering through this escape or overflow by the means already described.

Avoid any contraction of opening into the waste-pipe, while arranging it so as to prevent escape of spoons, etc., and let the trap be fixed as close as possible to the bottom of the trough, providing a brass cleansing-screw for access to the trap. The trap and waste-pipe one and a half inch

or two inches diameter. Large traps and waste-pipes are insanitary.

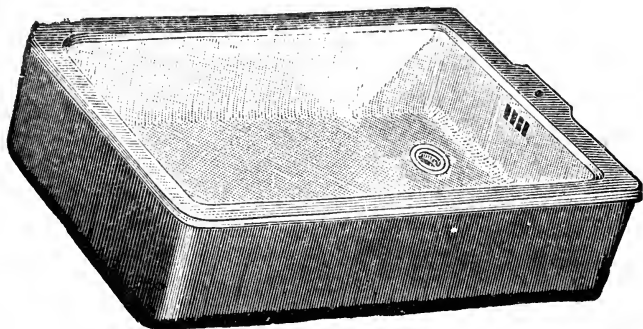

FIG. 241.—White enamelled fire-clay scullery trough.

The brass grating, whether it be always open or fitted with a plug and washer, should be sunk in a hollow cone below the level of the bottom of the trough.

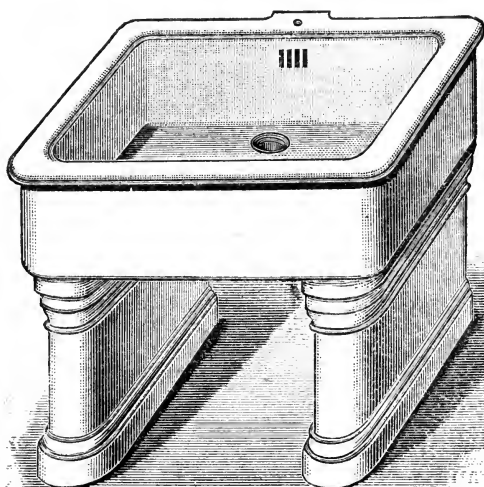

FIG. 242.—White enamelled fire-clay scullery trough and stand with overflow at back and brass plug and washer on waste.



The lead flashings of all such troughs against walls should be very carefully and neatly executed.

Drainers should be arranged also, the best material being cast fluted lead laid on sloping timber shelves draining into the troughs. Sometimes fluted timber is used, covered with sheet lead dressed into fluting; but such lead cuts easily and wears out soon. The author prefers fluted hard-wood drainers wherever the cast fluted-lead drainers are too costly.

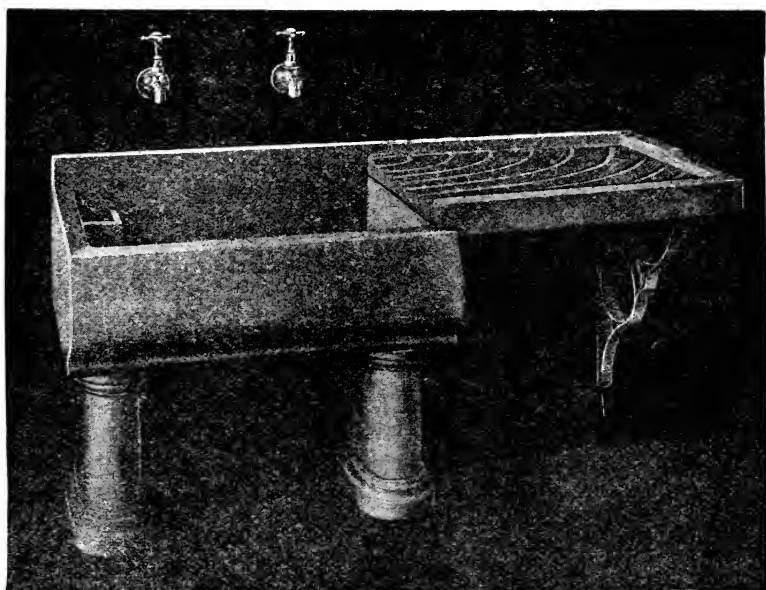

FIG. 243.—Adams' white glazed trough and stand with drainer.

This trough has an inside standing overflow formed in the glazed ware, so that the water may be held if required. Waste is fitted with brass plug and washer. The drainer is of the same material as the trough.

In all good laundries earthenware troughs are now used

with great advantage. This material is cleaner and more durable than any other; a good arrangement is here illustrated.

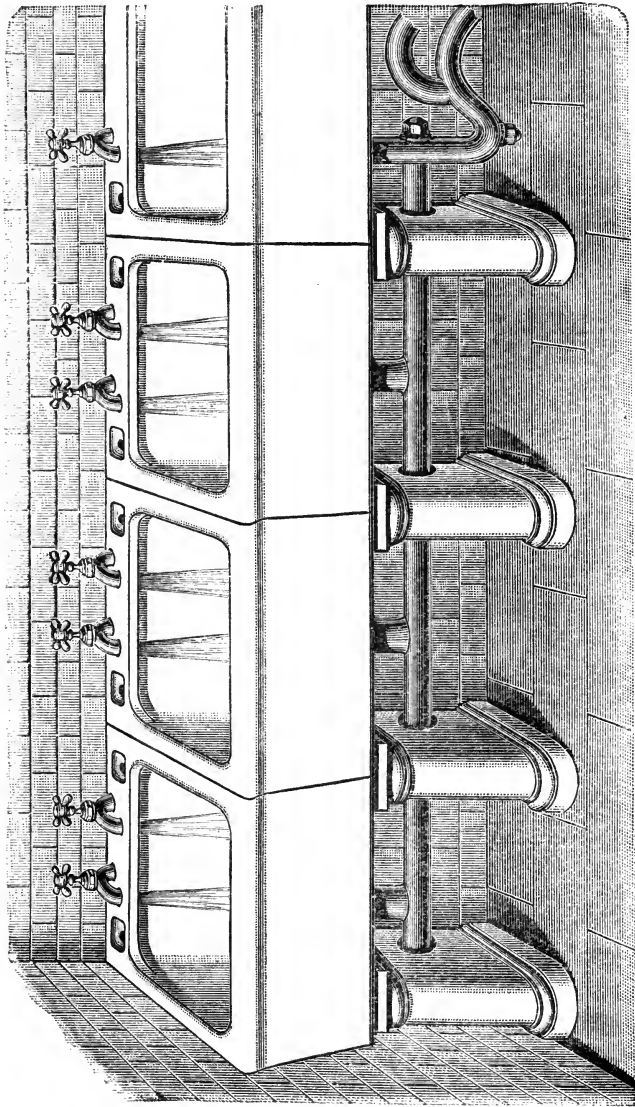

FIG. 244.—Range of white enameled earthenware washing troughs.

Bathrooms and baths are now fitted up so luxuriously that several chapters would be required to exhaust the subject. Cheap and simple baths should be arranged for

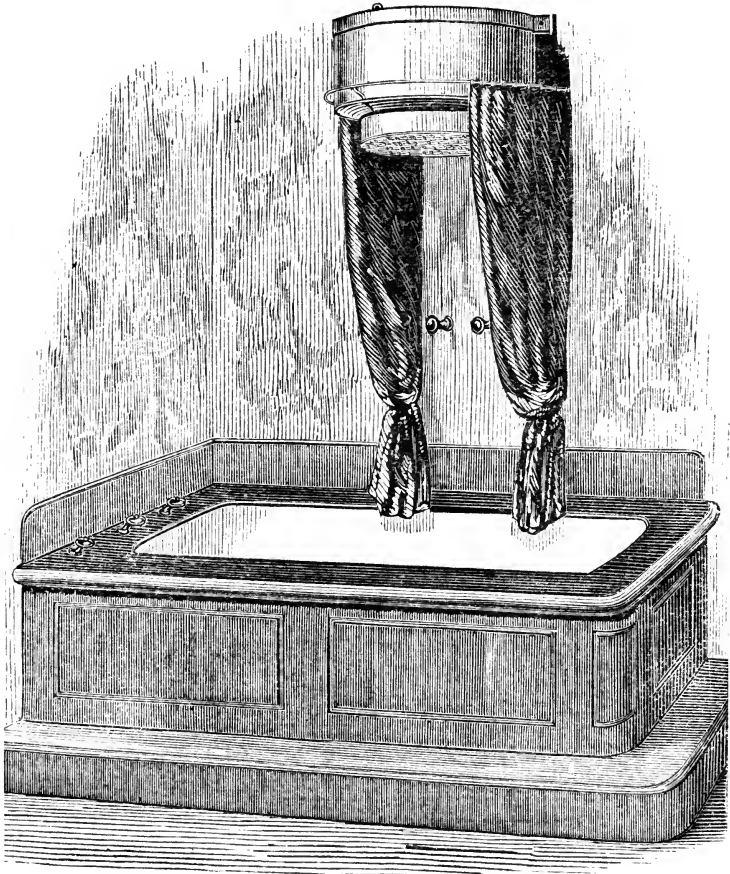

Fig. 245.—Reclining and shower bath, complete.

moderate houses to encourage their general adoption in the community.

Copper reclining baths are very properly considered the most satisfactory and durable, and are capable of any

amount or style of decoration. Enamelled earthenware baths are also excellent, presenting a beautifully smooth white surface, and being almost everlasting. They take some time to become warm when warm water is admitted, and they are clumsy and heavy to move when fixing.

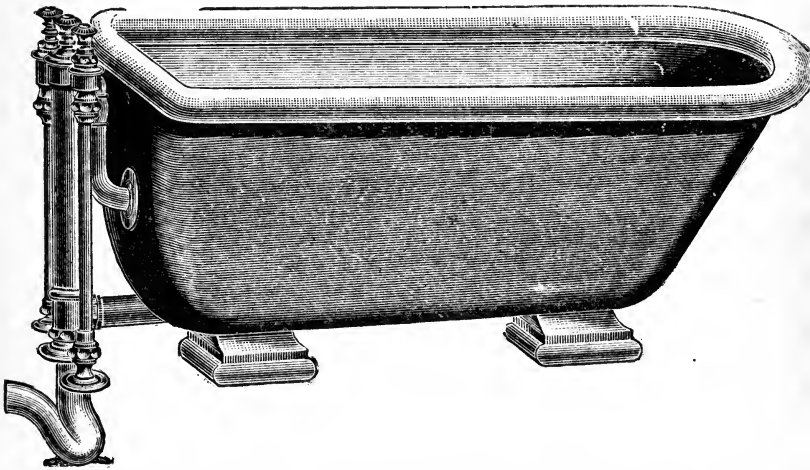

FIG. 246.—Earthenware white enamelled bath complete with brass fittings.

Both these makes of baths are expensive, and therefore only suited to luxurious mansions.

Zinc baths cannot easily be preserved clean-looking or inviting in appearance, and japan or enamel surfaces will not adhere to zinc. Even in France, where zinc baths are much used, calico sheets are laid in them to keep the body from contact with the metal.

Lead-lined wooden baths are found in old houses, but have given place to improved forms and more suitable material.

Cast-iron baths are the best cheap baths, but oxidization must always be expected to appear in time, even through the best japan.

White-glass enamelling looks well at first, but is certain to chip where hot water is used, as the iron expands and contracts much more freely than the enamel, and the cost approaches that of the lighter copper baths, which are much better. Japanning, when well done, in three or four coats, stoved after each coat, and hand polished, as tea-trays are

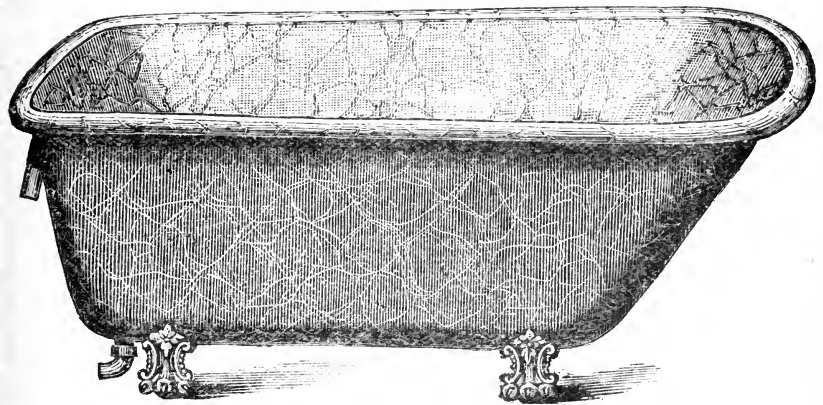

FIG. 247.—Cast-iron independent reclining bath.

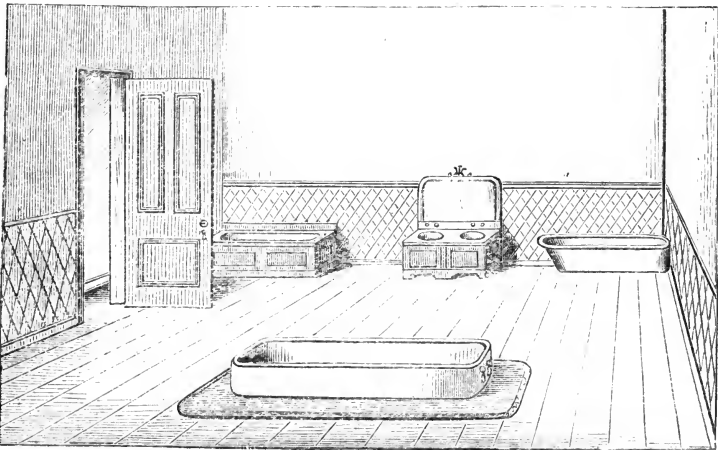

FIG. 248.—Sunken bath in centre of bathroom.

polished, has an excellent appearance, does not chip like vitreous enamel, and is cheaper.

Cast-iron baths, well painted with a varnish paint, answer very well when a better class cannot be provided.

Tiled baths and marble baths are used in mansions and in luxurious Turkish baths, and at hospitals and hydropathic establishments. They are generally very large, and sunk partly or altogether below floor level, some having three or four steps leading into the water, with hand-rails for invalids to hold by.

Designing proper arrangements of baths will be found part of the plumber's best work, and well worthy of careful attention and original thought.

All high-class bathrooms should have impervious tile floors, and tiled walls up to a height of six feet, the upper portion of walls and ceiling being painted. Paper absorbs moisture too readily, and is unsuitable for bathrooms of high class, but when varnished is frequently used with advantage in ordinary bathrooms.

The bathroom should be provided with a means of heating for winter, which can be arranged by a copper coil of pipes, having the hot-water supply circulating through. Towels and sheets can be hung to warm on the coil while the bath is being taken. It is always unsafe to take a hot bath in a cold bathroom. Cast or wrought iron heating coils are unsuitable, as they rust the water of the circulating system, and iron-mould the towels and sheets laid on them. Sometimes the hot-water cistern can be placed in the bathroom, so as to utilize heat in winter, both for warming the room and the bath linen. In summer, of course, there should be an easy way of diverting or encasing the heat, otherwise the bathroom would be too hot. It is a bad practice to employ

the domestic hot-water system for any more extended heating arrangement in the house.

Bathrooms and lavatories should never be arranged over reception-rooms or bedrooms; sooner or later some accident may happen to cause widespread ruin to decorations and furniture.

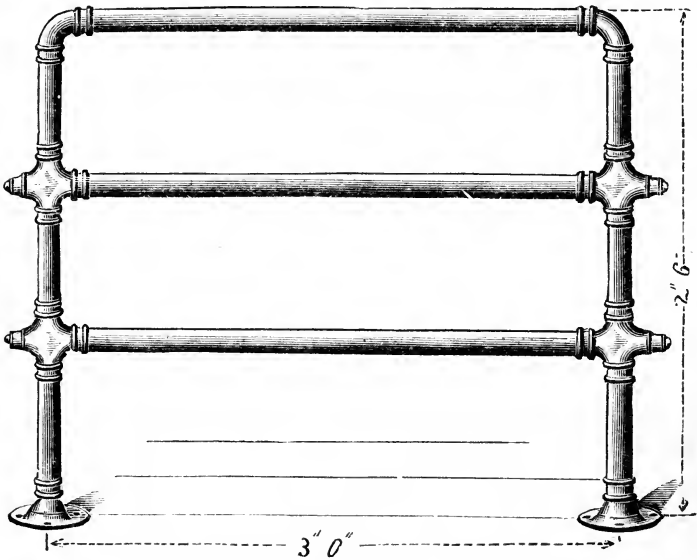

FIG. 249.—Copper heating coil. A towel rail.

Hot and cold water is frequently delivered into the bath through the same pipe and grating in the bottom, by which the dirty, soapy waste water from the previous baths had been run off. This should never be allowed, for these bath-wastes are soapy, and cannot be kept quite clean.

The ordinary size for a reclining bath is 5 ft. 6 in. long at top, 4 ft. 6 in. long at bottom, and 2 ft. 3 in. deep, but many are fixed larger, where water is abundant. For nursery use the bath need not exceed 4 ft. 6 in. long at the top.

When, to meet water companies' rules, the hot and cold supplies are brought over the top and above the overflow, the bathroom becomes filled with steam, which condenses on the cold walls and does much injury. If permitted, the

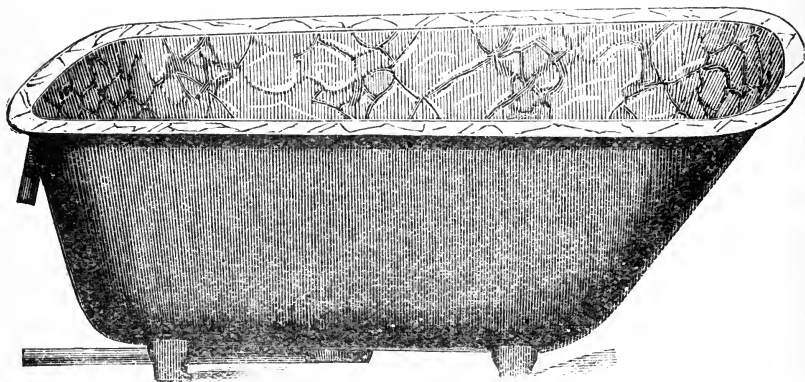

FIG. 250.—Bath with supply delivered through waste-pipe.

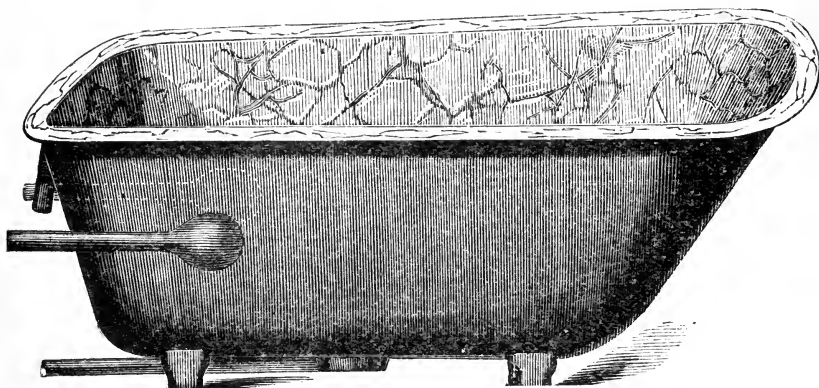
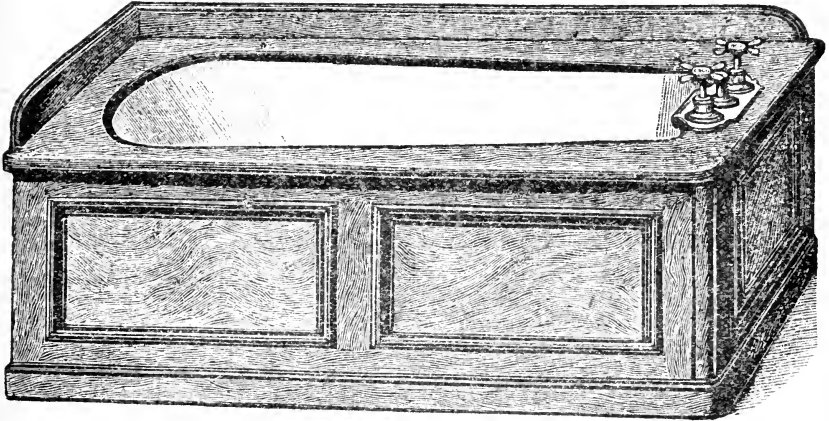

FIG. 251.—Bath with supply separate from waste-pipe.

best method of delivery is to bring the hot water in at one side, and the cold water in opposite, near the foot end, and about three inches over the bottom, through large brass gratings; the overflow being taken from the foot, through a



large grating also three inches below the top, care being taken that the area of the overflow pipe and grating is not



• FIG. 252.—Reclining bath arrangement with water taps at end.

contracted at any point of its bends or length, and that it is capable of taking all the water that can possibly be let into the bath. Under some regulations, the overflow must go direct to open air, to act as a warning pipe.

The waste-pipe and waste-valve should be 2-inch diameter heavy lead pipe, trapped beyond the valve with a deep syphon trap having a cleansing screw, the overflow-pipe being joined in below the valve and above the trap, and a 2-inch vent-pipe, for protecting the water-

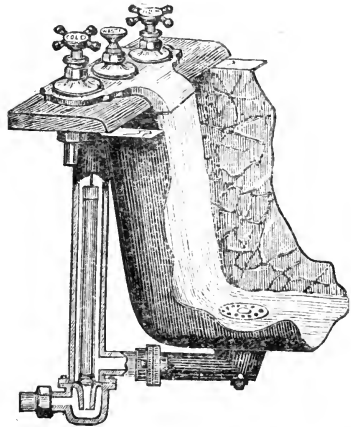

FIG. 253.—Section showing a frequent arrangement of water taps at end of bath, with waste-pipe, plug, stand-pipe, overflow, and trap complete.

seal of the trap from violation, should always be taken from the outgo of the trap to the open air. The waste-pipe should, if possible, be carried separately to open air, and either delivered into a safety disconnecting receiver, having a grating very wide open for ventilation, or in some cases it may be convenient to deliver over or into a rain-pipe. Equal care must then be taken to disconnect the rain-pipe from drain contact.

There are many large mansions and castles where large heavy lead soil-pipes pass down inside the house, which

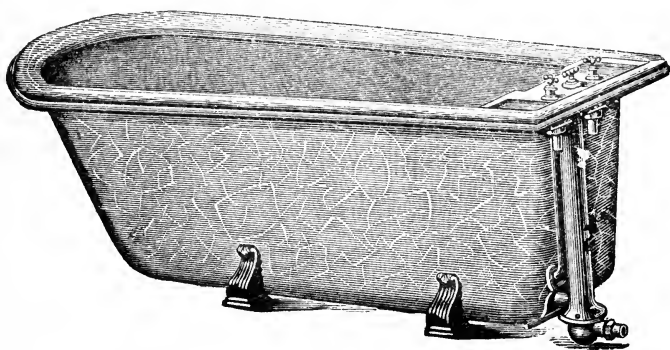

FIG. 254.—Independent cast-iron bath with wood capping.

cannot be placed elsewhere, and these houses frequently have housemaids' slop-sinks with hot and cold water discharging into the soil-pipes, and baths are close by whose wastes are connected into the soil-pipes, and cannot easily be carried down separately. In such a case, even when the soil-pipe is very strong and well fixed, well disconnected at foot, and ventilated fully with inlet and outlet full bore of pipe, the waste of the bath should not be joined into the soil-pipe.

Hard and fast rules forbid this connection, and if the plumber knows his trade, and his work be supervised by

someone knowing his business, this connection will never be permitted without protest.

Figs. 254 and 255 exemplify the growth of the demand for baths whose fittings are all attached complete. They are made and sold in hundreds, and are preferred on account of the small amount of plumbing work required about them.

The hot and cold taps, waste and overflows, traps, and soap-stands are all connected complete to these baths, and nothing remains to do but to connect them with the plumber's pipes. These are instances of the tendency to minimise the plumber's interest in building construction.

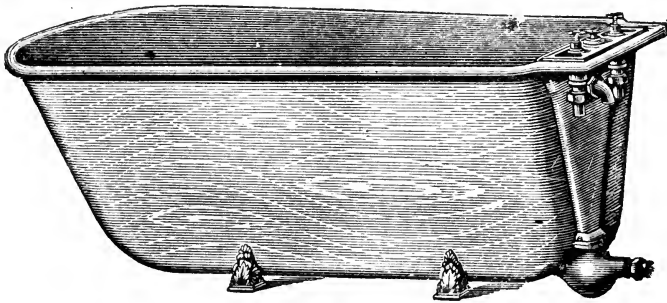

FIG. 255.—Independent cast-iron bath, complete.

In the improved independent bath illustrated by Figs. 256, 257, and 258, instead of concealed standing waste and overflow there is an open recess in which the valve rod works, and which is finished like the interior of the bath. The grating, of specially large size and opening, is fitted *above* valve with a slotted or bayonet catch arrangement, so that it can be removed with the fingers for cleaning or other purposes. The valve rod being usually of strong nickel-plated brass, and working through this grating, is a most cleanly, strong, and simple arrangement. The overflow is cast on immediately behind the waste recess, and enters the

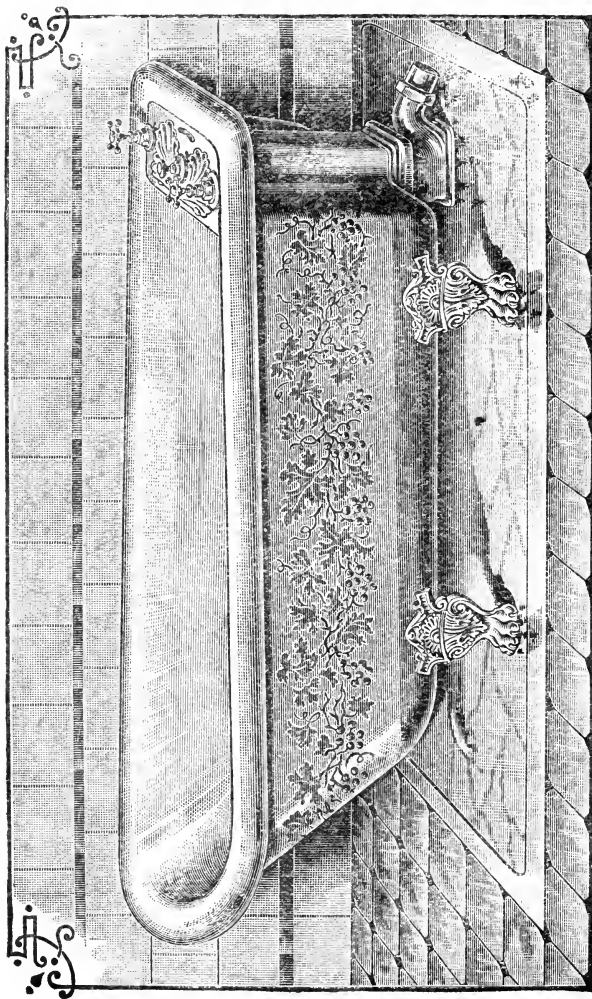

FIG. 256.---Improved independent reclining bath.

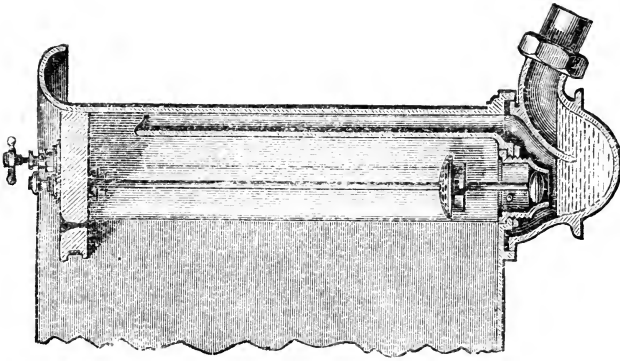

FIG. 258.—Section of end of Fig. 256. This shows grating removed from its seating. Can be removed and replaced with the fingers.

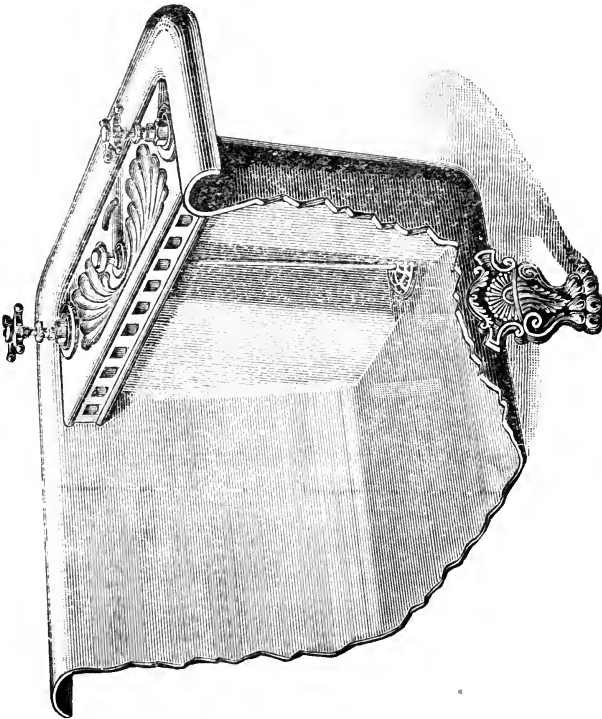

FIG. 257.—Interior view of Fig. 256. This shows inside view of fittings with large porcelain slab containing soap trays and access hole to overflow.

waste just above seal of trap. Every time the taps are turned on, a special nozzle, led from the taps to the top of overflow, throws a jet of clean water down the sides of the overflow channel, and so keeps it always clean. Furthermore, it is raised as high as possible in the bath, so that the chance of overflow and consequent soiling is slight, except

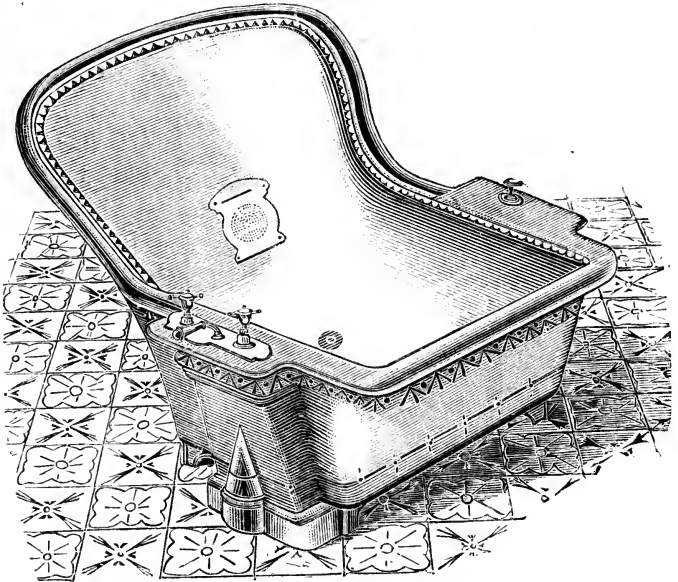

FIG. 259.—Independent sitz-bath.

in the case of taps left running with waste valve closed, in which case the overflow is sufficient to take away all the water.

The trap is made a circular full-way throughout, glass-enamelled inside, and being removable and adjustable to suit different directions, it is much preferable to the older forms of dip trap. A flange is put on the trap at floor line for a neater finish. The hot and cold taps are of the best screw-down description, and are covered by a massive slab of

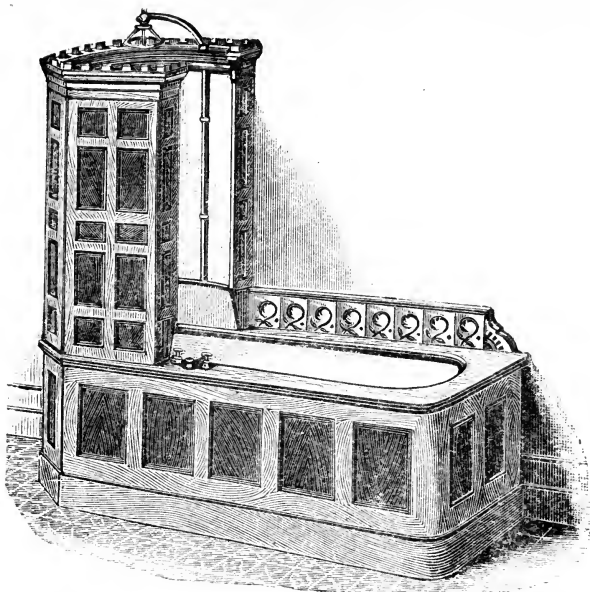

FIG. 260.—Open-top plunge, shower, and spray bath.



FIG. 261.—Independent open-top cast-iron reclining shower and douche bath.

porcelain, containing two commodious soap trays. An open overflow, with a connection for overflow pipe, can be made on this bath to suit the requirements of the water companies, who insist upon this construction of overflow.

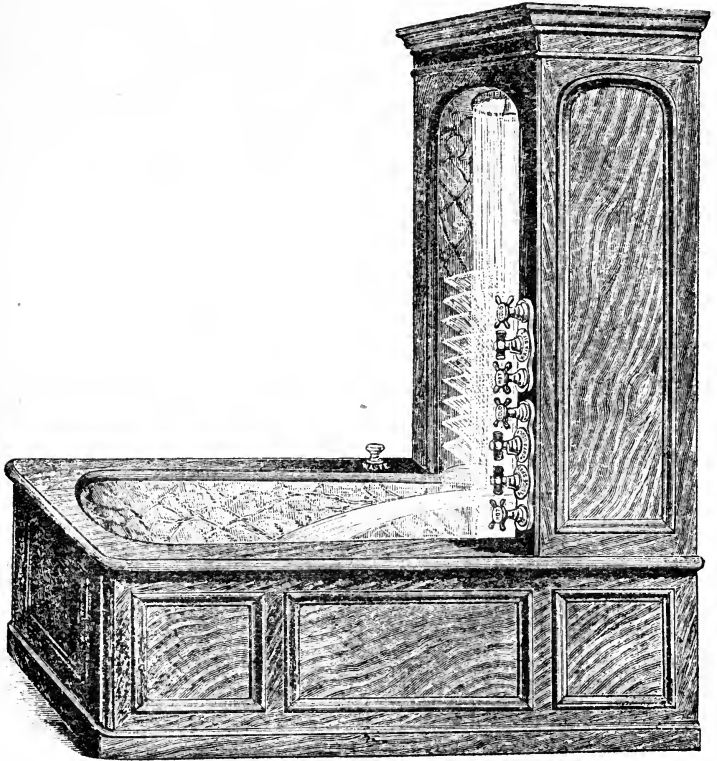

FIG. 262.—Wood-encased reclining shower and douche bath.

Fixed sitz-baths (as Fig. 259) are now frequently fixed in bathrooms. The supply and waste and overflow arrangements should be similar to those described for plunge-baths.

Architects produce special designs for their bath fittings in important mansions, and plumbers must be prepared to work intelligently to their designs. Baths costing from



£100 to £500 each are occasionally erected where expense is no object, and rare materials, with art workmanship, are required to be in character with high-class surroundings.

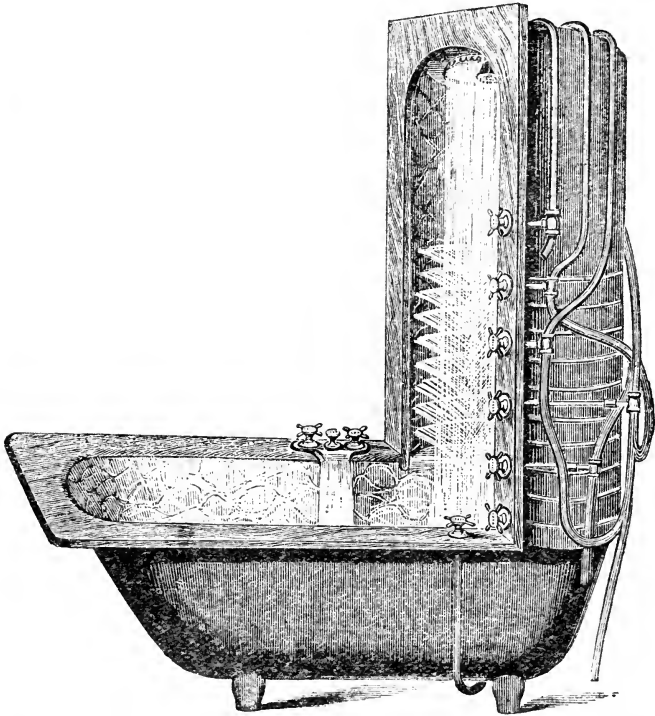

FIG. 263.—Reclining shower and douche bath, the wood casings removed, showing arrangement of pipes, etc.

Casings of copper or zinc are now being fixed in luxurious bathrooms at the head of the baths, with pipes attached and fine holes pierced through the casings, to give needle-douche baths all round. Shower-baths are likewise arranged overhead, and sometimes a cold-wave douche is added.

These baths, being complicated by so many valves and pipes, must be of the very best construction, otherwise they constantly get wrong and are eventually removed.

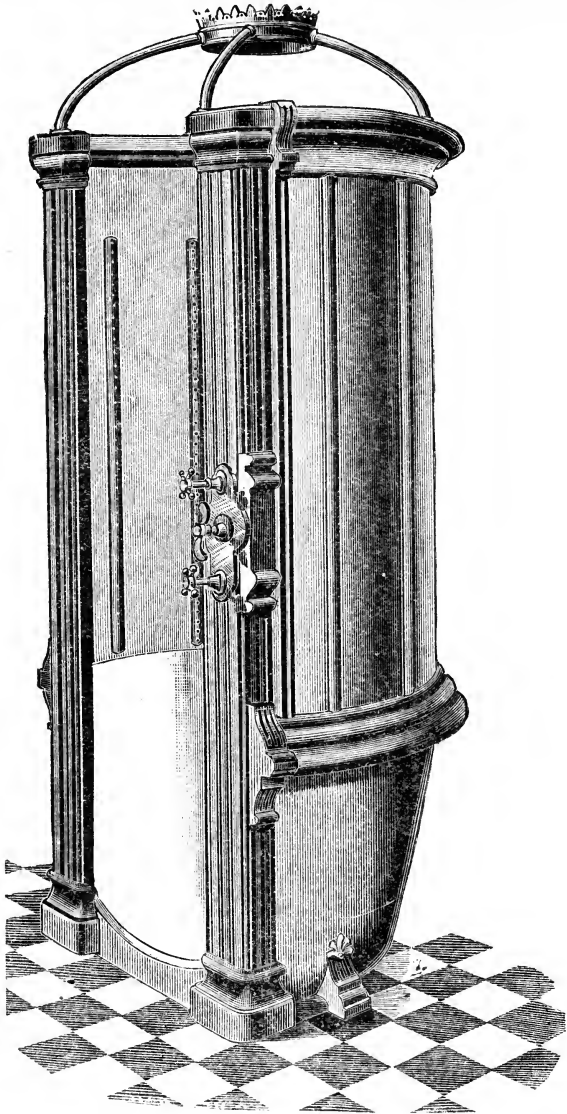

FIG. 264.—Spray, douche, and shower bath.

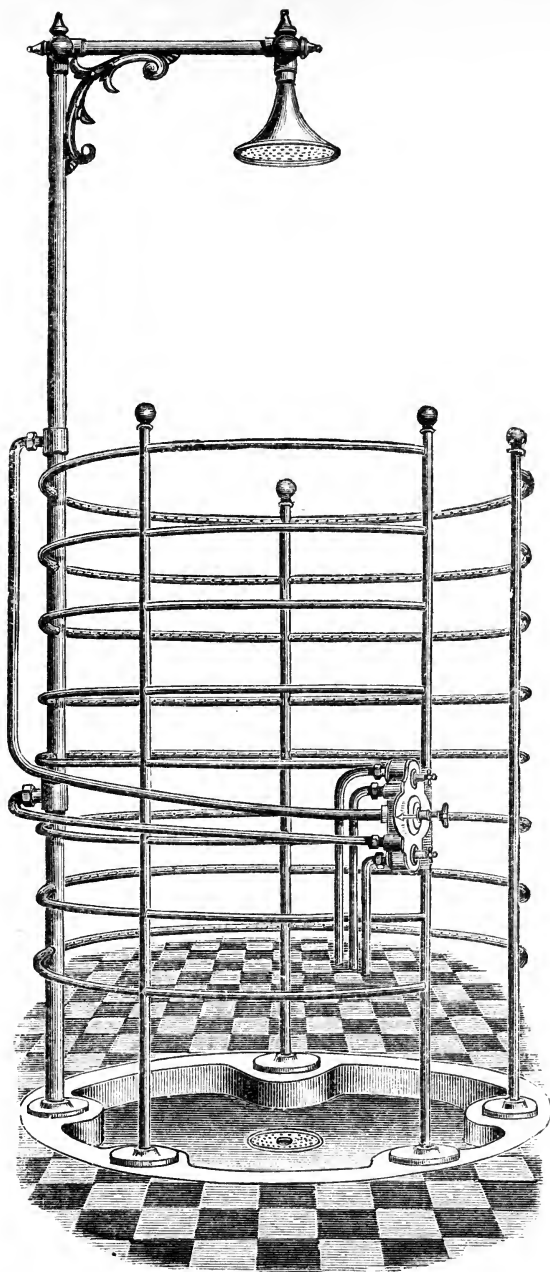

FIG. 265.—Needle-spray bath, with shower and ascending spray.

Generally speaking, the simplest arrangement of bath, with ample space, plenty of water, and unlimited power to splash and dash water about the person, without fear of injury to walls or ceilings, will prove the best and most satisfactory all-round bath.

Needle-baths are formed with horseshoe-curved copper



FIG. 266.—Encased lavatory for dressing-room.

or brass tubes fixed in horizontal lines one over another, connected by three or four vertical pipes, and fitted with shower rose, side-spray rose, and vertical rose, throwing spray up from the ground. They are used principally in public and private Turkish baths.

Fixed washhand-basins or lavatories are coming more and more into general use, and as they are now being placed in

dressing-rooms and bedrooms, much care must be given to render them safe fixtures in such positions.

The waste-pipe and trap should be one inch in diameter, not larger, but the area of the grating should be sufficient to fill the waste-pipe full bore.

The best method of discharge is through an ordinary

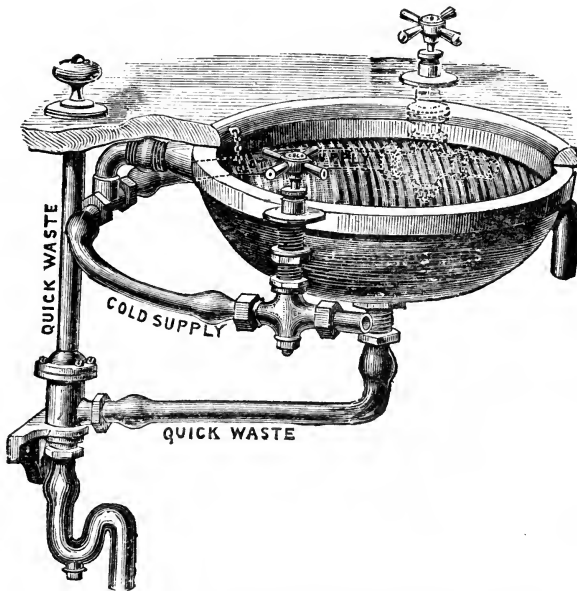

FIG. 267.—Lavatory basin arrangement, with flushing rim.

1-inch round-way cock, fixed between the grating and the trap, with the handle and lever carried through the front casing. There is no simpler or more certain method.

The hot and cold  $\frac{1}{2}$ -inch supplies should be taken in through special horns prepared for them, one at each side of basin, and discharging all round the basin by a flushing rim, so as to wash down soap-suds adhering to the sides of the basin. The  $\frac{1}{2}$ -inch valves on the hot and cold pipes

may be lever or screw-down valves, and the handles may also come out through the front casing, or the valves may be fixed in the wall so as to leave the marble slab or porcelain top free of any projection, to allow of its easy drying with a cloth. The overflow may be led to the open air, or into the trap under basin.

The waste-pipe must be made as short as possible, for it never can be absolutely quite pure, and it must discharge in the open air in an absolutely pure position.

A lead safe-tray should be provided also, having its waste open to the air direct, with a copper flap-valve on the end.

We have illustrated here another arrangement of waste-

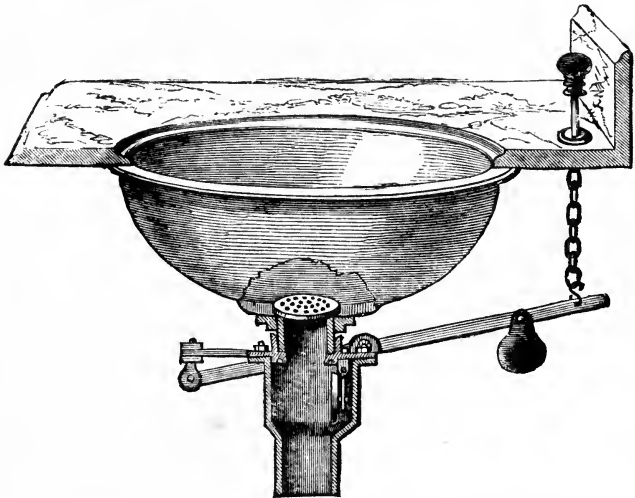

FIG. 268.—Basin with valve and lever to waste-pipe.

valve for washhand-basins, actuated by a chain pull and lever, which close the valve, as in the valve water-closet, against a watertight seating. It is a cleanly and neat arrangement, but the difficulty of repairing the valve pre-

vents its general adoption. Sanitarians seek for simplicity in construction.

The object of the antiseptic hospital lavatory (Fig. 269) is to meet a demand for a lavatory in which a surgeon may wash his hands after an operation without risk of contagion.

The supply taps are placed underneath the basin, and are

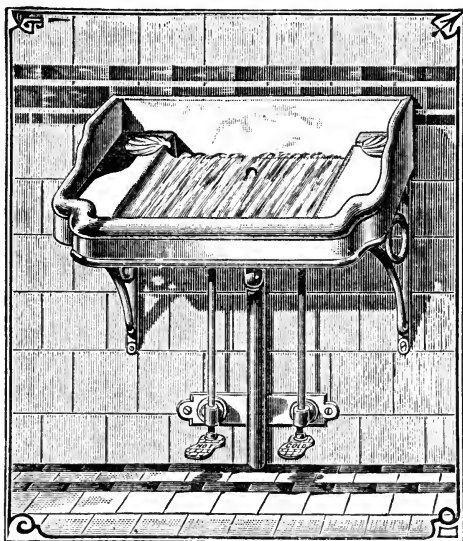

FIG. 269.—Antiseptic hospital lavatory.

actuated by means of pedals. The water enters the basin from a perforated rim in the front made in the earthenware, and overflows the weir at the back, so that the hands may be washed in constantly running water. The waste is an open orifice behind the weir, connected to a trapped down-pipe. The basin is emptied by a small hole leading directly to the waste outlet. It is not sufficiently large to interfere with the filling and overflowing of the basin when in use,

but is quite ample to empty the basin in a very short time when the taps are closed.

The independent lavatory (Fig. 270), with all parts fully exposed and accessible, is a very excellent arrangement.

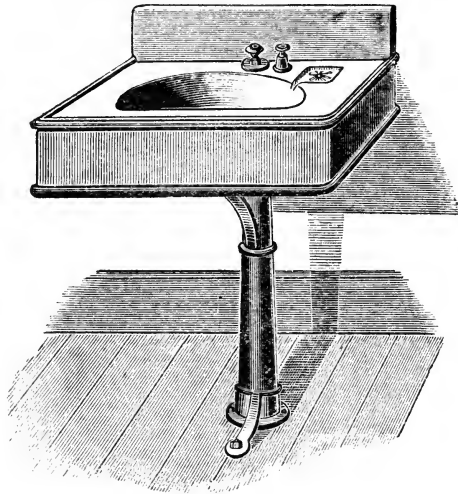

FIG. 270.—Independent lavatory.

Washhand-basins and basin tops, in numerous shapes and

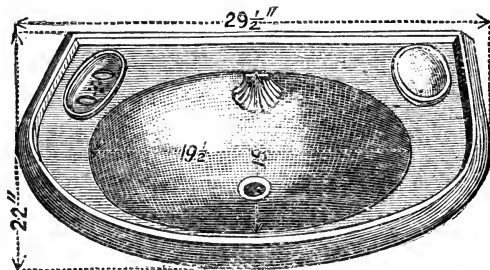

FIG. 271.—Oval basin, pottery ware lavatory top.

designs of pottery and earthenware, are made by many firms, and are largely fitted up. The best kinds are made



with a slope towards the back, and the waste going off at the back also.

The overflows should be always sufficient to carry off all the water which the taps can possibly admit at full bore. It is very seldom indeed that we find the overflows large enough, and the pipe sufficient to prevent an overflow. The point is a very serious one for plumbers, as damage may result from neglect.

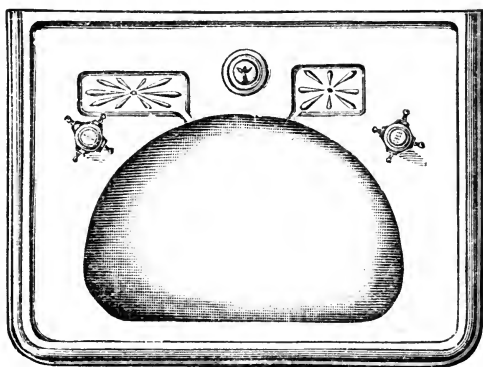

FIG. 272.—D-basin, with hot, cold, waste, and overflow.

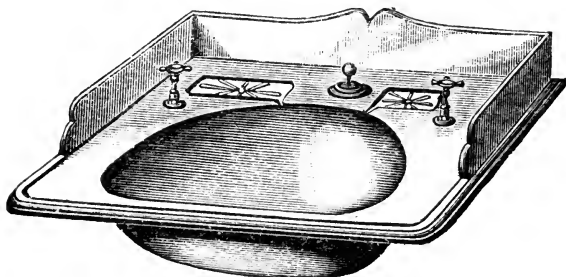

FIG. 273.—D-basin, with hot, cold, waste, and overflow, and skirting.

The washhand-basins above illustrated are made in a D shape and much used, the straight side being next the user, and affording great width and scope for free movement in washing.

These basins have also an arrangement for douching the face with cold or tepid water in a very agreeable fashion, which is a luxury added to these fixtures. Four taps are, of course, necessitated to produce this result and control the supply. The arrangement is shown in two of these illustrations (Figs. 274 and 275).

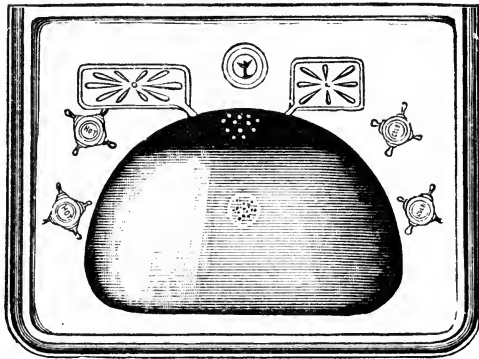

FIG. 274.—D-basin, with hot and cold douche arrangement added.

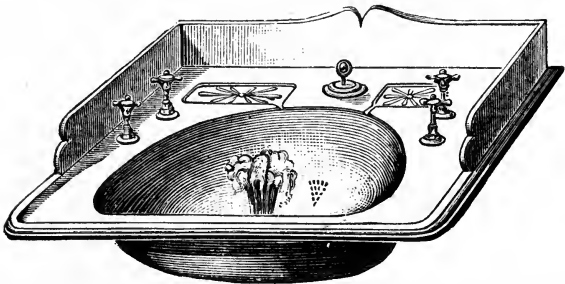

FIG. 275.—D-basin, with hot and cold douche arrangement added.

D-shaped basins are also made for corners of rooms where space is limited. The arrangements are precisely similar to those with the flat-wall back.

The demand for fixed basins has grown very rapidly in Great Britain, as before referred to, rendering it desirable

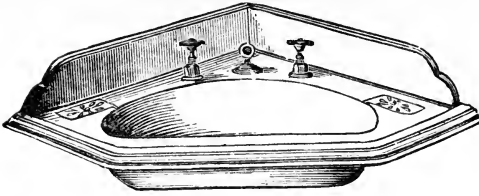

FIG. 276.—D corner basin, shown in position.

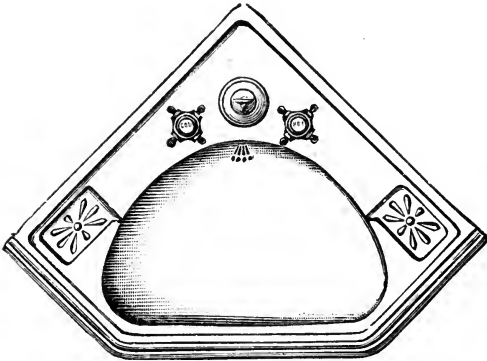

FIG. 277.—D-shaped corner basin, top plan.

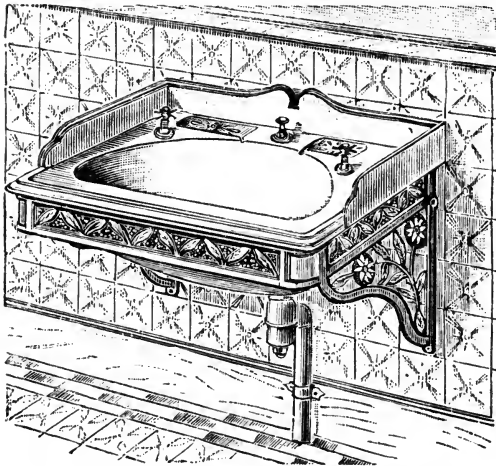

FIG. 278.—Lavatory on bronzed iron brackets.

that we give a few illustrations (Figs. 278–284), more as suggestions to plumbers, to guide them in the methods

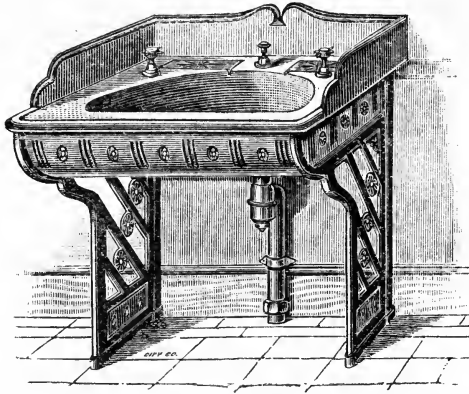

FIG. 279.—Lavatory on bronzed iron brackets.

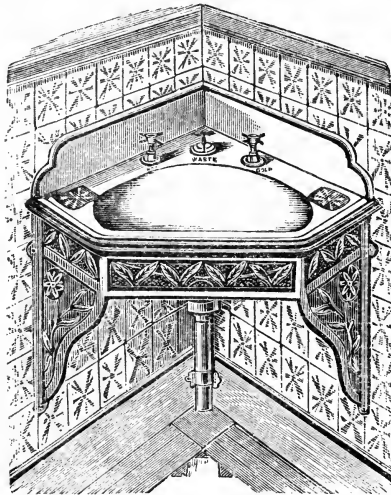

FIG. 280.—Corner lavatory on bronzed iron brackets.

which may be adopted in the fitting and finishing of such appliances.

The old-fashioned plan of sunk soap and brush trays,

with small waste-pipes leading from them into the basin, is now obsolete, being superseded by the sunk trays with open grooves draining into the basin.

Originality in design is sought for in such work, and in

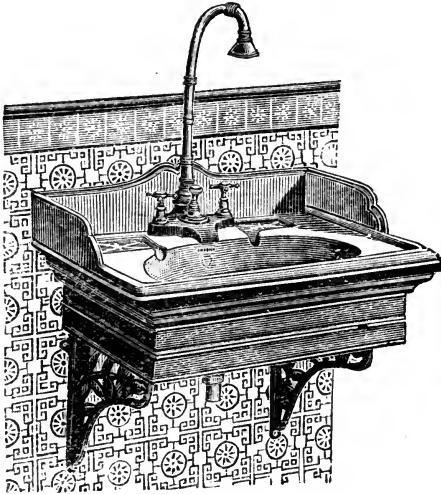

FIG. 281.—Shower shampoo lavatory on brackets.

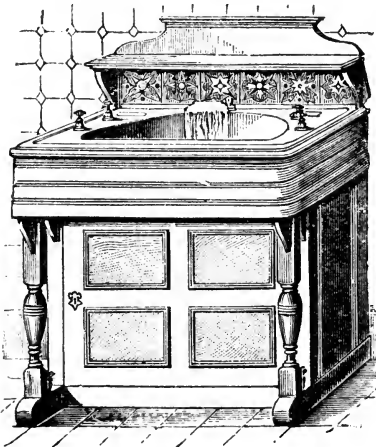

FIG. 282.—Handsome wood-encased lavatory.

new mansions the architect will probably design special fittings, which the plumber must ever be ready to work to zealously.

Architects are frequently much pleased to find a design

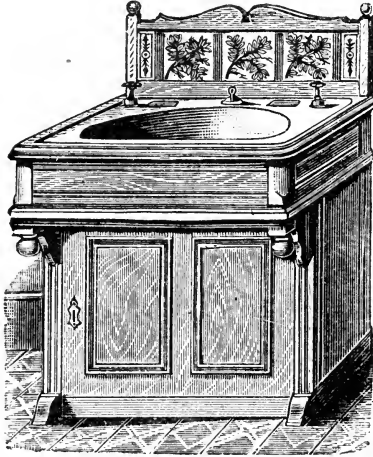

FIG. 283.—Handsome wood-encased and tiled lavatory.

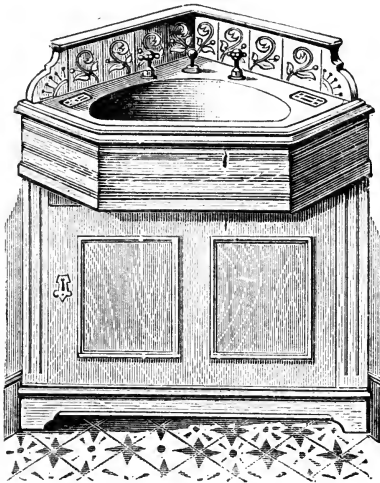

FIG. 284.—Handsome wood-encased corner lavatory.

suited to their requirements ready to their hand, and in such matters it is the plumber's duty and interest to give all the assistance in his power, and to place his special technical and trade knowledge and experience at the architect's disposal. There is nothing more agreeable to a good tradesman than to find an architect willing to consult with him, and to accept any suggestions from him likely to improve the work in hand.



FIG. 285.—Adams' cabriole lavatory.

Adams' cabriole lavatory stands, with marble slabs and white ware heavy washhand basins, are very neat and effective sanitary appliances in dressing-rooms, and if hot and cold water is laid on and waste-pipe safely arranged, they save domestic labour, and are convenient, healthy, and ornamental.

This lavatory is carried on polished brass brackets, as here illustrated; the basin is 26 inches long, and the outlet trap is made of brass.

Plumbers will do well to notice how rapidly designers

and manufacturers are improving all the appliances formerly made by and put together by plumbers; it is admitted that the demand for these fittings is very extensive. Architects and employers welcome every appliance calculated to reduce the amount of skilled labour required on contract work, as such labour has not hitherto been easily obtained; and, as demand always ensures supply in every market, in one way,

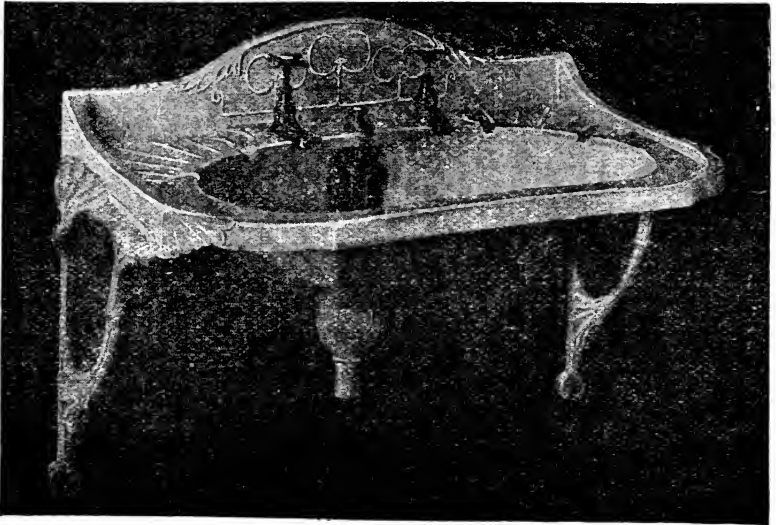

FIG. 286.—Adams' large oval titanite lavatory.

if not in another, artisans should take the lesson to heart, make their labour the best of its kind, and render it in a manner agreeable to those who employ them, so that the feeling in the employer's mind when the work is done may be satisfaction, rather than repulsion, accompanied by stern determination never to employ a workman again. If workmen would do their utmost to turn out sound work without wasting time over it, the demand for work would increase four-fold.



One very serious defect is found in the baths and basins of modern construction, and it should be remedied by the makers. The overflows are made too small. Every overflow should be ample to carry off all the water that can possibly be turned on when all taps are running full bore.



FIG. 287.—Modern form improved lavatory.

For hospitals and institutions the corbel form of lavatory basin is approved. It affords free access to the floors and walls for cleansing. The basin is supported wholly from the corbel built solid into the wall.

The adamant lavatory also is much used, and its perfect cleanliness and simple construction must always commend it from the sanitary point of view.

These illustrations (Figs. 288–294) explain a very good

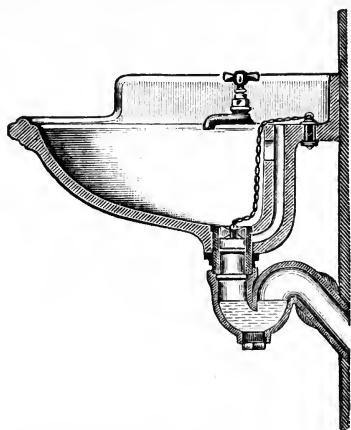

FIG. 288.—Section of improved lavatory.

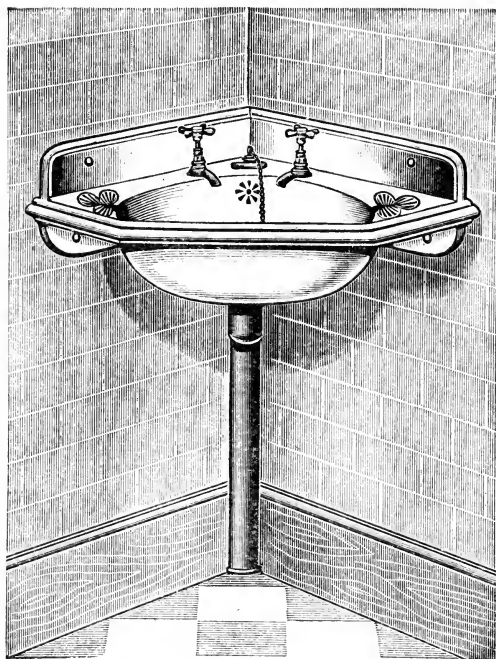

FIG. 289.—Improved corner lavatory.

form of improved modern lavatory suitable for schools, hospitals, and public places. The basin is made of white enamelled earthenware, with full-way accessible waste and trap.

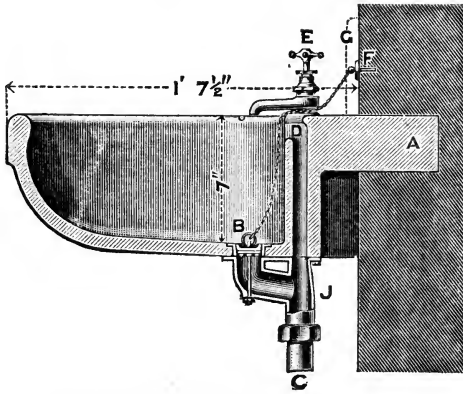

FIG. 290.—Corbel lavatory in section.

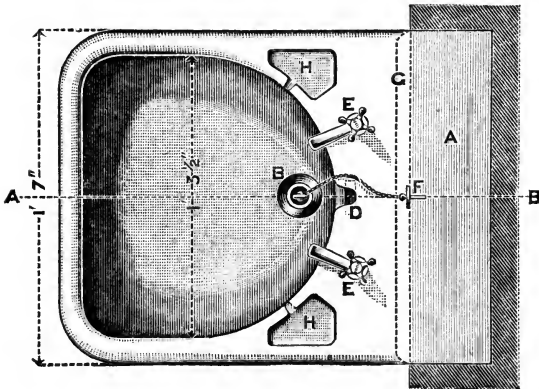

FIG. 291.—Corbel lavatory in plan.

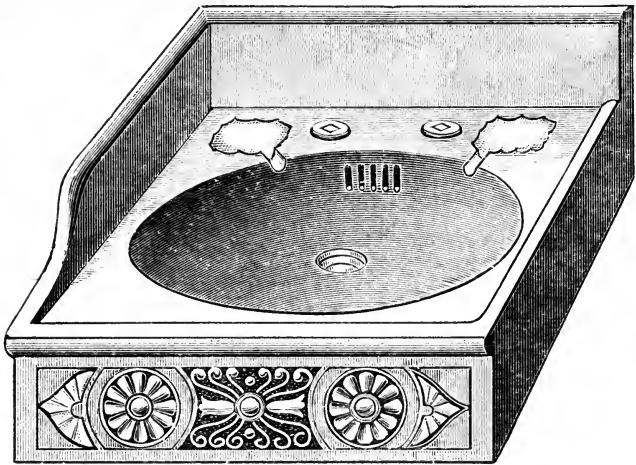

FIG. 292.—Adamant lavatory.

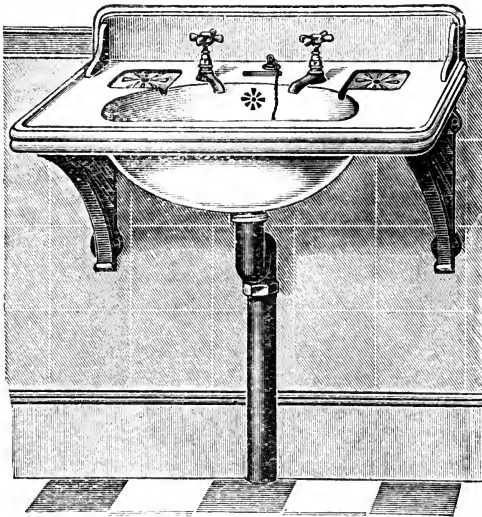

FIG. 293.—Improved flat lavatory.

The simple form of lavatory shown on next page, when substantially made, is a good one for schools; for in such

institutions plumbers should be careful to fix none but simple, strong appliances.

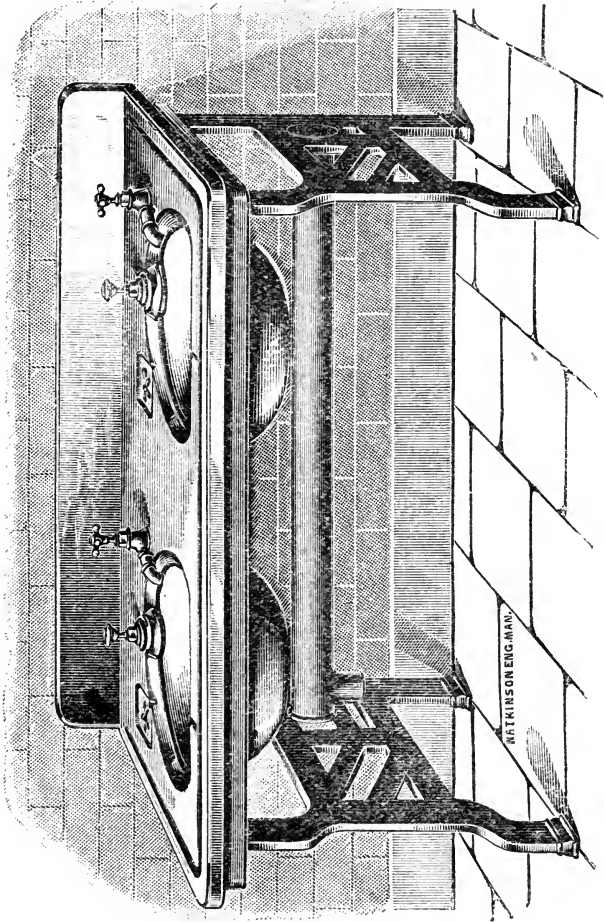

FIG. 294.—School lavatory.

The slabs are best of polished and oiled slate, with plain chamfered edges and skirting, and sunk soap trays. The height of the slabs may be fixed for junior schools at two feet from floor, and for senior schools at two feet five inches

from floor. Sixteen-inch fire-clay **D**-shaped bowls will be found a suitable size for schools.

Lavatory tops are now made in most artistic designs; some of those which we have seen costing over £100, and being really good value for that amount.

In America these fixtures are used in every mansion and

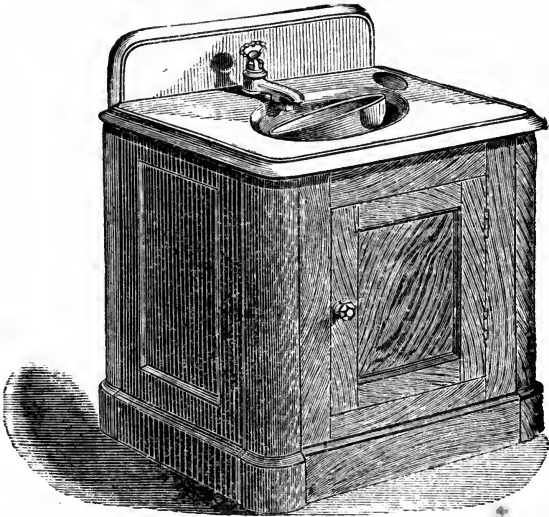

FIG. 295.—Tip-up lavatory, with marble top and wood casing.

in every dressing-room. Domestic labour-saving appliances are more thoroughly appreciated on the other side of the Atlantic than with us.

Patented appliances are more numerous in America for the same reason, and invention receives its reward more certainly.

A basin with a syphon waste arrangement can also be used in some positions, arranged so that by closing a valve in top of syphon it will syphon out, while by opening the

valve air passes in, stops the syphon action, and leaves it acting as a simple overflow, trapped, of course, beneath, and with waste-pipe delivering in open air. Hot and cold supply by means of flushing rim is the best system.

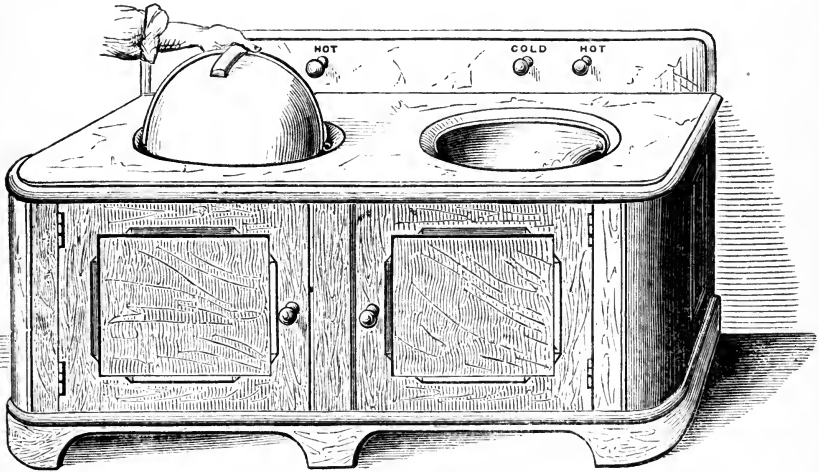

FIG. 296.—Tip-up lavatory, marble top, wood encased.

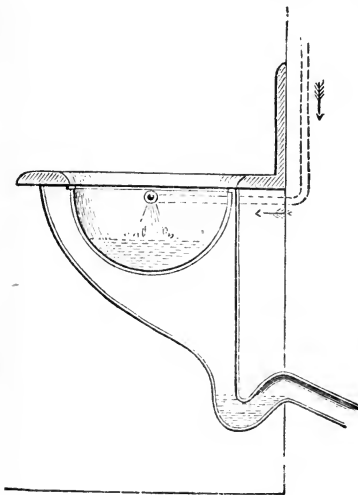

FIG. 297.—Tip-up basin filling.

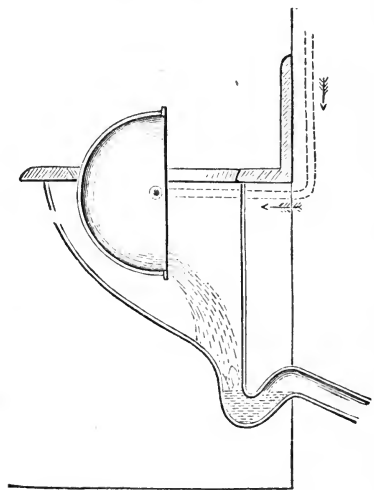

FIG. 298.—Tip-up basin emptying.

Tip-up basins have large interior surfaces, likely to get foul, and even when made to lift out for cleaning, this duty is not attended to, or the basin gets broken in lifting it in and out. The trap below the basin, owing to the sudden discharge of water, is liable to unseal itself by the momentum of the water.

Tip-up basins are also made with the inlet for hot and cold water through the journals right and left, on which the basins revolve. This arrangement is liable to go out of order, difficult to adjust or to repair, and the basins cannot be lifted out.

Waste-preventing cisterns for water-closets we may consider here.

Ingenuity has been exercised over these inventions until there ought to remain no more difficulties to conquer.

It is well that every closet should have its own separate cistern, but these cisterns should hold and discharge three or four gallons at each flush.

Waterworks authorities limiting the supply for closets to two gallons should be prosecuted, instead of being protected according to law. Such prevention of legitimate use of water causes filth and disease in many places, and encourages underhand practices, and eventually causes more waste than it prevents.

A well-directed flush of three or four gallons of water is requisite to wash out a water-closet, soil-pipe, and drain, and to clear out the interceptor trap. This usage is not waste of water, but is the very use that water is valuable for. The meaning of "to waste" is to keep unproductive, while public health demands abundant supply. Plumbers will do good public service by always contending for a full flush for water-closets each time of use, but to oppose all dribbling as undoubted waste.

The simplest principle of waste-preventing cistern is that



in which the ball-valve is closed by the raising of the lever during the first half of the pull, while the outlet valve emptying the cistern and flushing the closet is opened during the second half of the pull. There is no after-flush provided to charge the basin, so that for valve and pan closets service-boxes must be attached under the cisterns, and even then the pull must be let go before water ceases to run. Care must be taken to ensure that the ball-valve is so arranged and guarded that the continued pull will not cut or strain the seating. All metal cisterns for closets should be galvanized or enamelled. A service-box is made of 4-inch lead pipe, with 2-inch inlet, 1½-inch outlet, and a ½-inch hole at bottom of an inner tube, placed so as to retain water during flush, and to allow it to flow slowly down after the pull is let go. A ½-inch air-pipe must be carried from the box up above the cistern. Each flush can utilise the full contents of cistern.

Double-chambered waste-preventing cisterns are made with a horizontal false bottom, in which is fixed a small lifting valve, while in the real bottom of the cistern is fixed the large flushing valve. A lever is connected to each valve at opposite sides of fulcrum, so that when at rest the small valve is open and water fills the lower compartment, whose large valve is shut, and when lever is pulled the small valve closes to prevent more water descending, and then the large valve opens and flushes the closet with the contents of the lower compartment.

The ball-valve supplies the upper compartment in ordinary way, having no strain on it. The objection to this arrangement is that only half the contents of cistern is given at each flush; that the lower compartment cannot be got at, to clean or to regulate the bottom valve.

The latter objection is avoided by making the division vertical, each compartment having its valve exposed, and a

connection is formed from the small valve into the flushing compartment. Still only a portion of the contents of the cistern is sent down.

The after-flush waste-preventers, made with three compartments and four distinct valves, are manifestly too complicated and difficult to keep in repair.

The tumbler waste-preventers consist of an ordinary cistern and ball-cock, fitted with a tumbling inner cistern

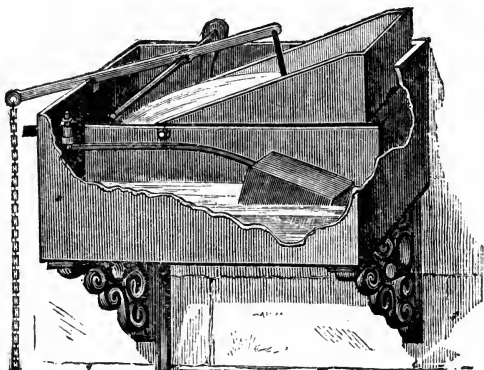

FIG. 299.—Tumbler water waste-preventer.

swung on bearings, which, on being actuated by the lever, cants up and discharges its contents suddenly into the outer cistern and down the service pipe. These are liable to splash and difficult to cleanse.

The syphon-action waste-preventers are numerous. Each one has a syphon in some form at the head of the service-pipe. In some the syphon is started by the water level in cistern being suddenly raised by plunging a piece of terra cotta or stone to displace its volume of water, which rushes over the syphon and starts it. Another covers the upright

mouth of syphon with a cap (Fig. 300), which the pull lifts, drawing up a charge of water with it, which pours over the

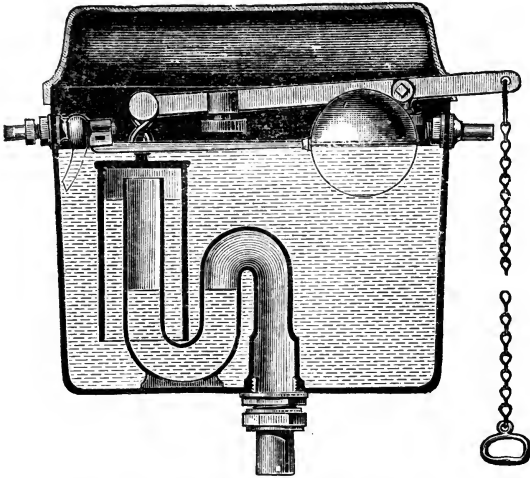

FIG. 300.—Capped double-syphon water waste-preventer.

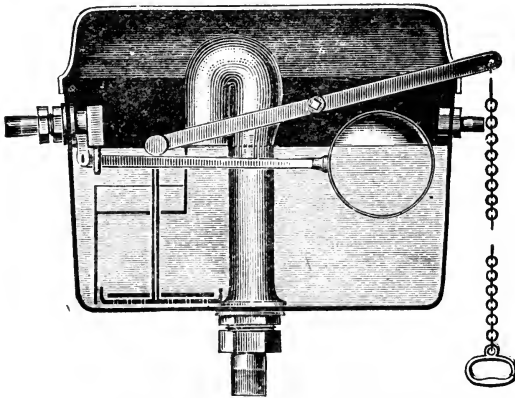

FIG. 301.—Lifting piston-syphon water waste-preventer.

syphon and starts it. Another uses a piston plunger to force a wave of water over the syphon (Fig. 305). Another lifts the water over the syphon by lifting a metal plate, thus

mechanically starting the syphon, and avoiding the use of valves (Fig. 301). Another syphon arrangement depends on the lifting of the ordinary water-closet flush-valve, which admits the water direct to the flushing pipe while holding

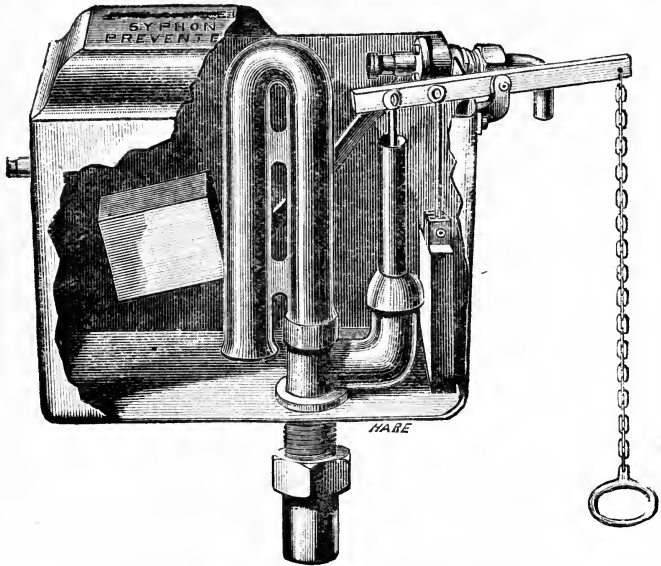

FIG. 302.—Valve and syphon water waste-preventer.

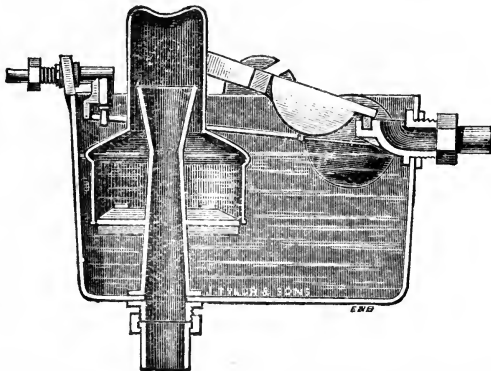

FIG. 303.—Capped single-syphon cistern water waste-preventer.

the ball-valve closed, and when the lever is let go the syphon starts, and continues the flush until the cistern is empty (Fig. 302).

The cistern illustrated above (Fig. 303) is made in galvanized cast iron, holding two or three gallons, and is

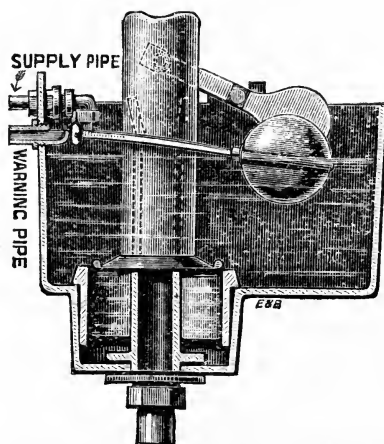

FIG. 304.—Capped single-syphon cistern water waste-preventer.

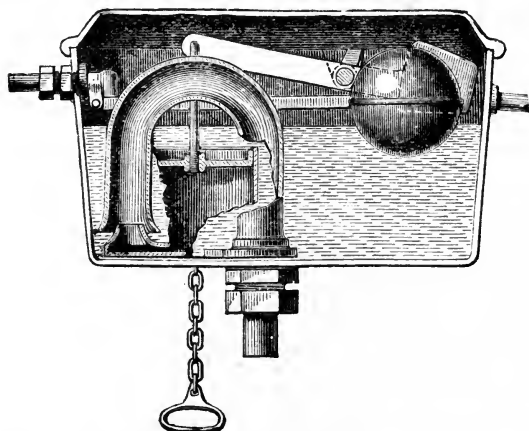

FIG. 305.—Valveless plunger-syphon cistern water waste-preventer.

fitted with a conical stand-pipe and copper dome. The pull, which can be actuated from either side, starts the syphonic action without the use of a valve.

Fig. 304 illustrates a cistern made in galvanized cast iron, with copper dome, which, when forced down, drives the water over the stand-pipe and starts syphonic action, without the use of any valve.

This cistern is made in galvanized cast iron. When the handle is pulled, a loose piston forces a jet of water from

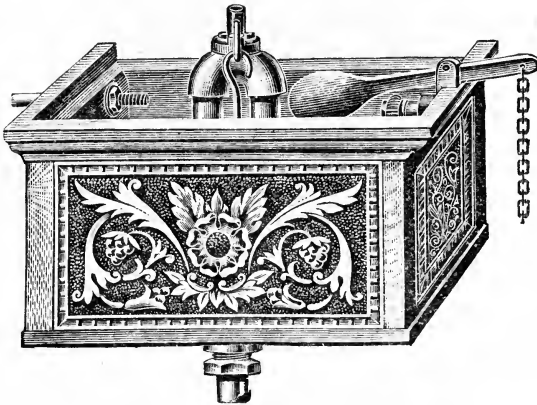
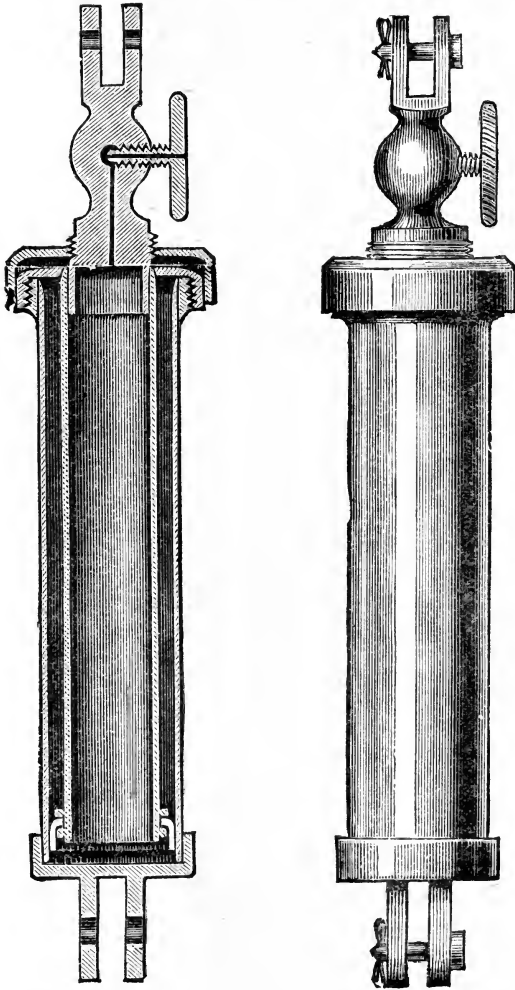

FIG. 306.—Mahogany encased cistern.

the cylinder into the syphon, which discharges the contents rapidly, whether the handle is held down or let go, and acts without any valve.

The objection to a syphon arrangement is the noise caused by the insuck of air at conclusion of the flush. They should not be used where the noise would draw attention to the neighbourhood of the closet. Patented arrangements are in the market by which this noise is almost completely checked by a ball valve, and the noise can also be minimized by carrying the mouth of the syphon into a closed box inside

the cistern, with an air-pipe and small supply-pipe to allow it to fill up while the cistern is at rest.



FIGS. 307 and 308.—Section and elevation of brass air-regulator.

There are many varieties of waste-preventing valves which can be fixed under water in ordinary cisterns on

the top of the service-pipes. The telescope waste-preventer is one of the best forms of these; but where waste-preventers must be used, it will be found better to use the waste-preventing cisterns, or the ordinary forms of regulators under the closet seats as next described, which can be easier got at for repairs.

The brass air-regulator shown on p. 347, which regulates the amount of water supplied to water-closets, washhand-basins, and urinals, consists of a cylindrical vessel closed at bottom, inside which another cylinder, closed at top, moves up and down freely; a cupped leather is attached to the lower end (as shown in section), which dips into a lubricant in the bottom of outer cylinder each time the inner cylinder descends, and thus renders the movement of the cylinder easy and air-tight. The inner cylinder is fitted with an air-escape hole at top, closed by a screw regulator which controls the time of descent of inner cylinder; and therefore, by attaching the upper portion of inner cylinder to the lever of the water-closet, which turns the water-supply cock or valve, and fixing the lower portion of outer cylinder in a convenient position, it efficiently regulates and controls the supply of water, and prevents waste.

The water waste-preventer illustrated opposite can be used without any alteration to existing fittings, by connecting it to the apparatus under the seat. It consists of a copper cylinder, as shown, with float and cam-action lever attached, acting against the valve in brass box on top of cylinder, and is connected to supply valve of closet at inlet A. When the valve is opened, the water passes into the waste-preventer at inlet A, to basin of closet through elbow B, and at the same time into the cylinder at D, gradually raising the float and closing the valve, after sufficient water has passed



to flush the closet. A small pipe is to be connected to the union at c, to act as a weeping pipe to charge trap of safe each time the closet is used, or it can be carried into the waste-pipe.

A good flush of water is obtained, however carelessly the handle is pulled up or suddenly let down, and with so little noise as to be unheard outside the closet. They can

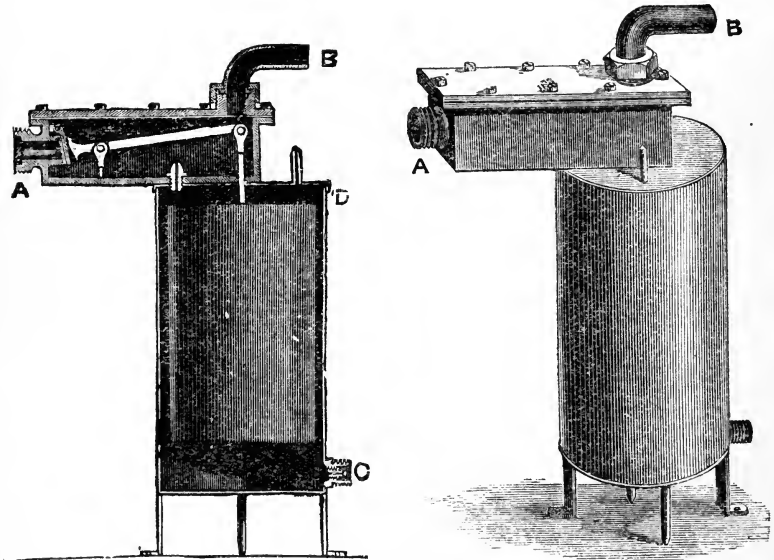

FIGS. 309 and 310.—Section and elevation of cylinder water waste-preventer.

be attached to existing closets without alterations to present fittings.

Flushing tanks of some form should be placed at the head of every important line of house drain.

Tanks with a water-tight valve, not less than four inches diameter at bottom, opened by pulling a lever, and filled by a tap and started daily, are as effectual as any, so long as they are attended to.

Automatic tanks are more useful, as the rain waters may be collected in them, and when they overflow the drain will be flushed clear. These may be constructed in any size or form, with syphons arranged having a widened overflow and a widened discharge, the latter sealed in a water-trap below, so that the air may be compressed in the syphon before the water falls over the lip and starts it. Automatic syphon flushing tanks have been in use many years.

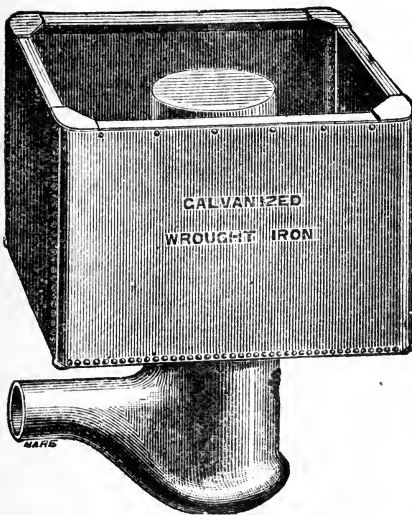

FIG. 311.—Iron syphon flushing tank.

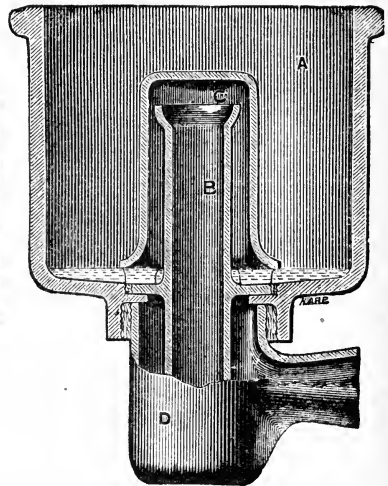

FIG. 312.—Earthenware syphon flushing tank.

By another arrangement the same result is attained. A water-tight valve in the tank is balanced at opposite end of a lever by a small tank. The overflow of the large tank fills the small tank and overbalances the lever, raising the large valve and flushing the drain. A syphon pipe from the small cistern into the large is started by the rush of water, and empties the small cistern back into the large one, when the valve closes, and the tank collects the water once more.

Public lavatories and conveniences—what shall we say of these, which are generally a disgrace to the country and

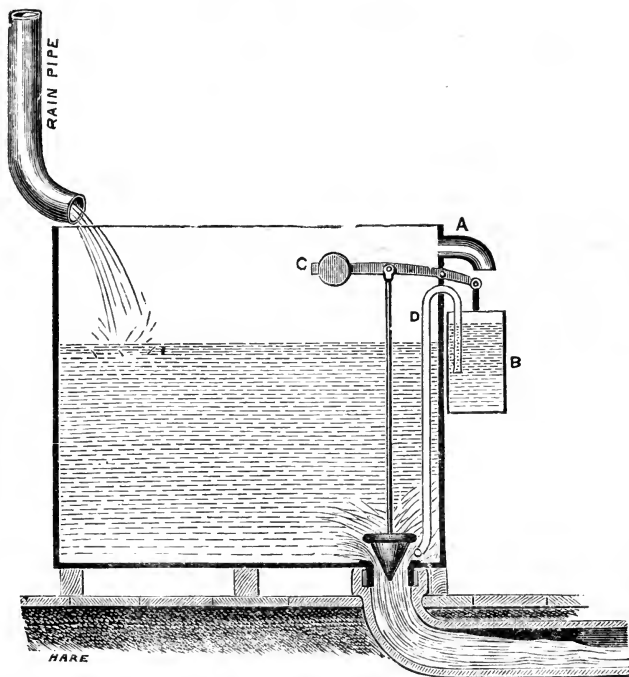

FIG. 313.—Automatic flushing tank.

a matter of surprise and disgust? If the chairmen and directors of the great railway companies could be compelled to inspect at least once a month all the appliances provided for the use of the travelling public of Great Britain, a very prompt and complete reform would be the result.

The state of the urinals is frequently quite intolerable, and the pungent smell of chloride of lime may be noticed everywhere, that cure being often worse than the disease.

These public urinals work well when made with long

troughs with some inches of water always standing in them, and with stand-pipe overflow, occasionally lifted for full flush, but kept overflowing by a slight constant dribble, or by an occasional flush from a small self-acting flushing tank. Gratings and troughs in the floor are most difficult to keep clean. Plain, impervious tiling should be continued up to the wall under urinal, and kept clean by the attendant washing the tiles daily.

The brass fittings, affording the plumber the power of drawing off or of stopping off cold and hot water in small pipes for domestic supply, will bring him much discredit if he employs inferior qualities of materials or supplies carelessly finished goods. Draw-off taps, stop taps, and ball taps should be the best of their kind; yet we constantly find plumbers buying the cheapest description from manufacturers, hoping to save a few shillings on contracts, but losing credit and money by the defects which soon appear in actual work.

Plug taps, requiring occasional grinding in to ensure staunch conditions, are very little called for now; but where they are adopted, care should be taken to get the gunmetal good and strong. Plug taps lightly made and cheap fail immediately when the least strain is put upon them. Owing to the fact that they cut off the flowing column of water with a sudden jerk, straining all the piping dangerously and causing a ramming noise, they are unfit for high-pressure water supply.

The high-pressure screw-down loose-valve taps, more in use than any other kind, are illustrated (Figs. 314 and 315) in elevation and in section.

These valves, thoroughly well made, are remarkably durable, secure from leakage under high pressure, easily repaired, and prevent concussion in pipes. They should always be

taken to pieces before soldering on, and the valve and stuffing-box removed, else the leather on the valve and

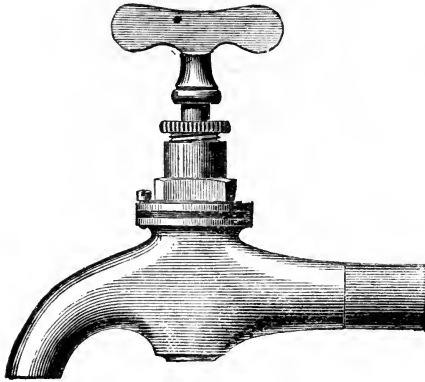

FIG. 314.—High-pressure loose-valve tap.

stuffing-box will be rendered hard and useless by the heat of soldering, and grease in stuffing-box will be destroyed and

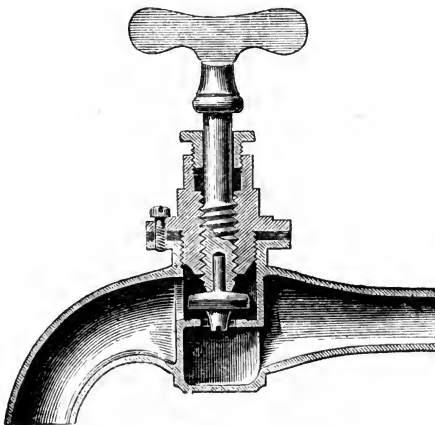

FIG. 315.—Section of same.

require repacking. This care is especially necessary with stop-cocks, as there are two hot joints to be made for each tap.

The taps here illustrated have a double closing action, so that the loose valve can be repaired without taking off the

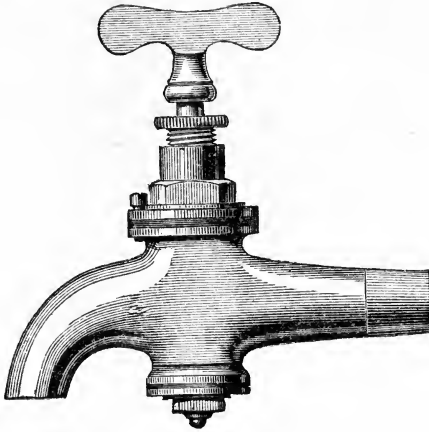

FIG. 316.—High-pressure loose-valve double-action bib tap.

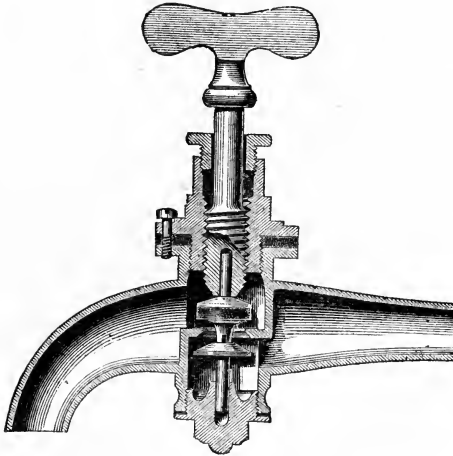

FIG. 317.—Section of same.

water. They should be used with gun-metal barrels for all good work.

These ball taps exhibit peculiar ease in turning, combined with quickness in opening and closing, requiring a rise or fall

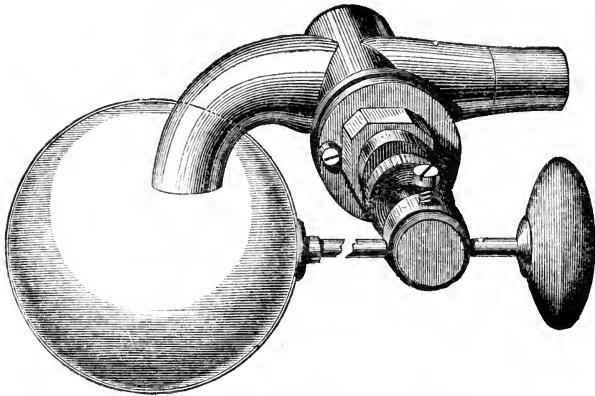

FIG. 318.—High-pressure loose-valve ball tap.

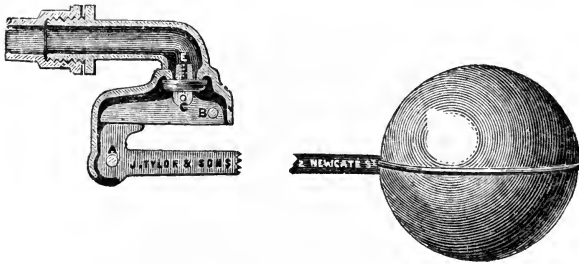

FIG. 319.—Direct-action ball tap.

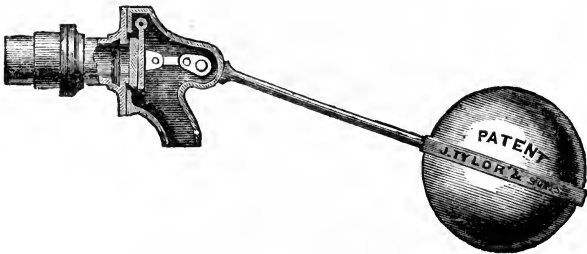

FIG. 320.—Direct-action ball tap.

of about three to four inches of water in cistern to complete the action.

The equilibrium ball valve has the advantage of simplicity

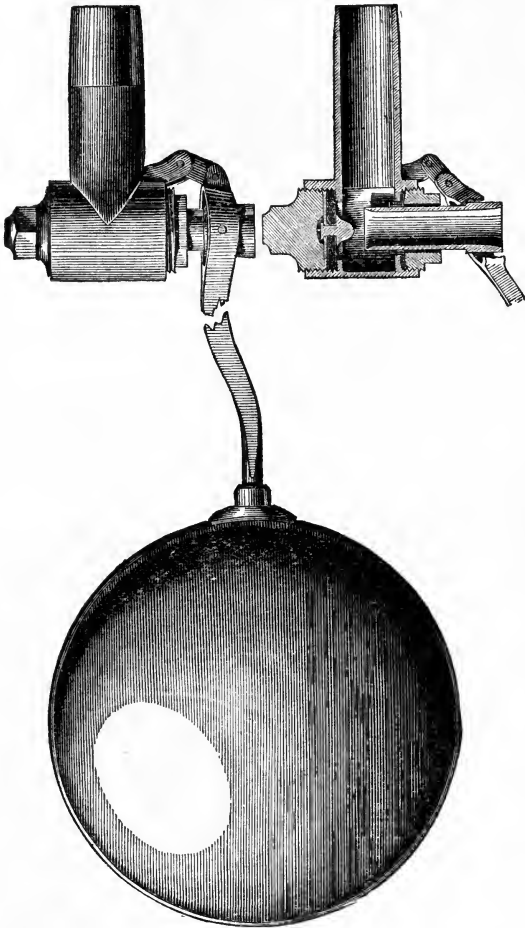

FIG. 322.—Section of same.

FIG. 321.—Equilibrium high-pressure ball tap.

in direction, but the writer has often experienced annoyance when equilibrium is disturbed, as sometimes happens, and a noise is set up throughout the whole house like sharp tapping, caused by the ball popping up and down in the



cistern, from the pressure of the water behind the valve acting against the pressure on the float.

Ball taps are often a great cause of worry. Plumbers as a rule have little idea of fixing or repairing properly; often half a dozen charges appear in an account for fruitless attempts at repairs, including larger balls, etc., etc.

When sent to repair ball taps of side boiler range cisterns plumbers often sit for half an hour watching for the last drop to come from the tap so that they can pronounce it staunch, and then if a little water is drawn off the boiler and the ball taps set running again another half-hour, etc., whereas a little common sense would show that the experiment could be repeated a dozen times in as many minutes by simply pouring water into the boiler and allowing it to flow back through supply pipe into the cistern and raise the ball to the proper level. You will seldom meet a plumber yet who thought of this, but when shown how the thing can be done many open their eyes in astonishment.

Something should be done to prevent lead shavings being allowed to get into pipes. After a house is fitted up there is often constant annoyance and often injury to valves by extra pressure, etc., in trying to stop the flow of water, which cannot be done until perhaps fire is put out, water drawn off, tap opened, and then found with damaged seat, etc., owing to lead shavings getting into it.

This ball valve (Fig. 323) is constructed to close at an extremely high pressure; in fact, it will close with ease at a pressure of three hundred pounds with an ordinary sized float ball. It is full bore, and a three-gallon flush can be obtained in one minute, while the noise so common with other ball valves is almost entirely eliminated.

The bath taps shown on p. 354 are constructed upon the same principle as the high-pressure water taps. The main feature consists in having a loose valve, the face of which

is covered with some flexible material, compressed on to a prepared metallic seat by means of a screw plug working in a stuffing-box. There are three cocks in combination, viz. for hot, cold, and waste water, connected to one pipe, forming the inlet and outlet to the bath, to be used as required. The principal object in introducing this description of bath cock is to get rid of the objectionable ground plug cock—whether used in combination for hot, cold, and waste water,

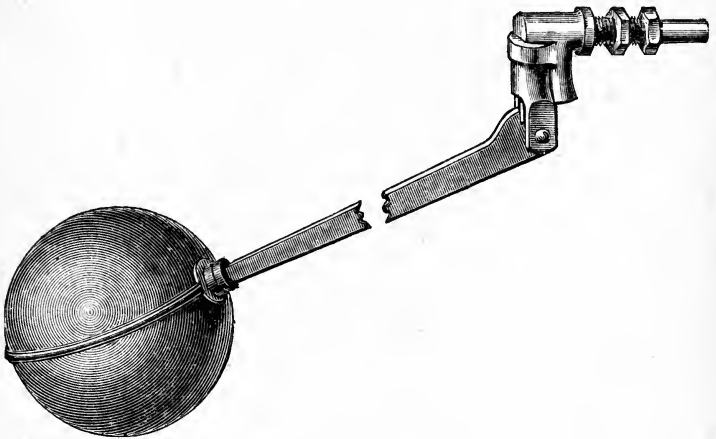

FIG. 323.—Eccentric ball valve. Templeton's patent.

or separately for such purposes—as all ground cocks, especially for high pressure or hot water, are particularly liable to soon become leaky and troublesome, and very difficult to repair, requiring to be unsoldered and removed from the bath; while, on the contrary, the high-pressure loose-valve cocks are very durable, and, should they become leaky, can be repaired in a few minutes on the spot, without any removing or unsoldering, by simply replacing the flexible washers of the valves.

The ordinary plug and screw-down bib and stop valves are known so well to plumbers that slight reference is required.

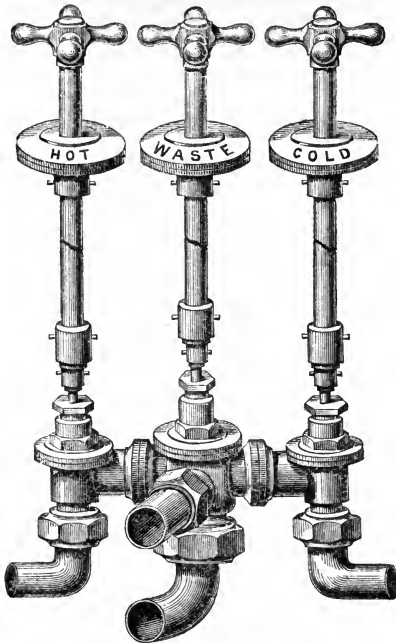

FIG. 324.—High-pressure loose-valve bath taps, combined with waste.

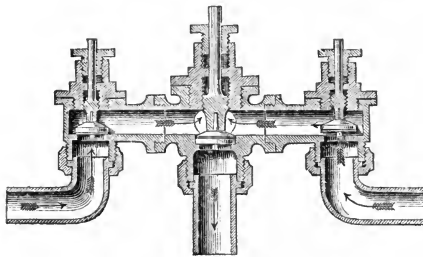

FIG. 325.—Cross-section of cocks.

The new system of bib and stop valves invented by Lord Kelvin is so far superior to the ordinary system adopted, that it is essential to refer to it very specially, and to illustrate the various forms in the market. Plumbers who are up to date know these valves, and appreciate them

highly. They are made completely of the best quality of gun-metal, highly finished, and tested to four hundred pounds per square inch; no rubber fibre or leather is, therefore, to be found in them. Packing round the spindle is also avoided, yet all parts are absolutely water-tight.

The gun-metal valve *A*, on reaching the seating *B*, also of metal, is not arrested suddenly, nor seated haphazard;

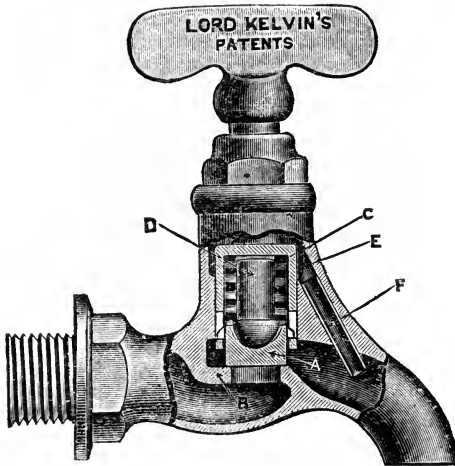

FIG. 326.—Draw-off tap. *A*, metal valve; *B*, metal seat; *c*, spring (non-corrosive); *D*, stop; *E*, angular space; *F*, eduction tube.

but, as the handle is turned, the valve also turns upon the seat, receiving a gradually increasing pressure from the spring *c*, applied on the centre by the rounded head of the stop *D*. The valve is thus rubbed on the seat at every opening and closing of the tap, maintaining a perfect surface, and even if the valve is damaged purposely, it will put itself right quickly by this friction.

No packing is required, as all water which passes the screw when the valve is open enters the annular space *E*, and is drawn off into the bib through the tube *F*, in which

a current is induced by the velocity of the water flowing through the bib.

The washers used in ordinary taps are well known to give constant trouble, and to require renewal. All materials tried have proved insufficient. Lord Kelvin abandoned them all, and metal to metal surface is for the first time adopted with full success; there are no perishable parts, and the valve and seating improve with use, instead of deteriorating as in ordinary systems.

The writer has used these valves with so much success, they are recommended without hesitation to plumbers.

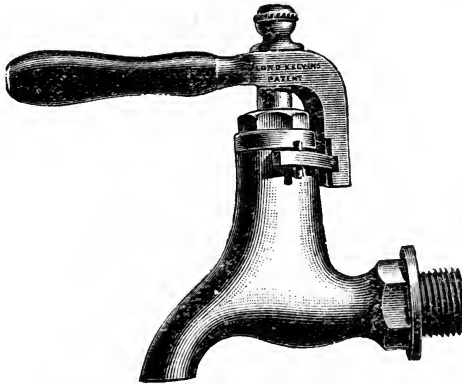

FIG. 327.—Kelvin new rapid opening tap.

A new form of tap for rapid opening, useful for hospitals, lavatories, etc., where water is wanted quickly, has been introduced with success, and is here illustrated.

In order to get the full opening with a quarter turn a coarse pitch of screw-thread was essential, and this has been formed round the barrel with excellent results.

These illustrations (Figs. 326–340) are given to enable the plumber to know the various forms of Lord Kelvin's taps, which he can obtain on the market without delay or difficulty.



FIG. 328.—Kelvin bib tap, vertical.

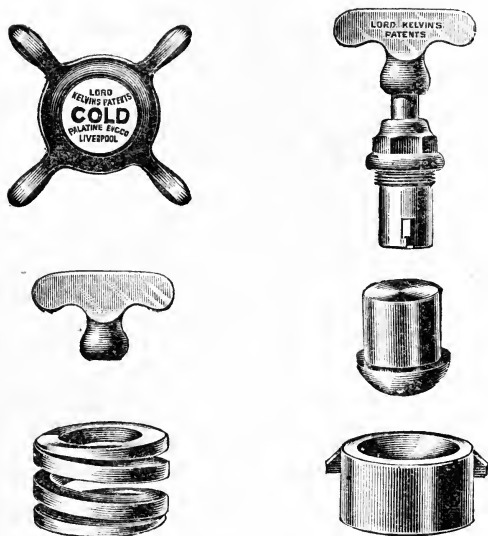

FIG. 329.—Details of Kelvin taps.

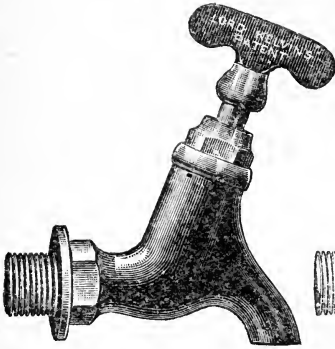

FIG. 330.—Kelvin bib tap, diagonal, with vulcanite handle.

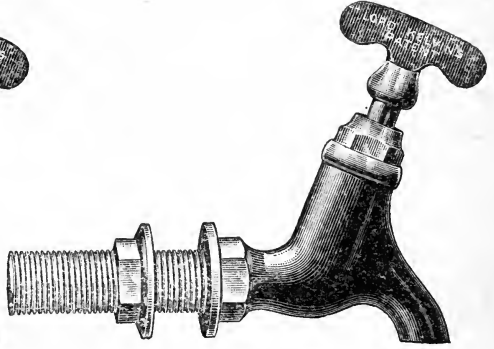

FIG. 331.—Kelvin range tap, with vulcanite handle for hot water.

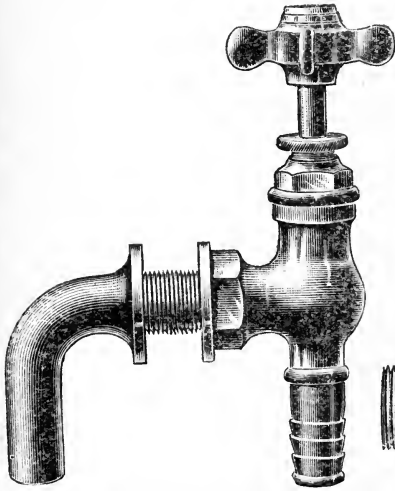

FIG. 332.—Kelvin bath tap, with bent union.

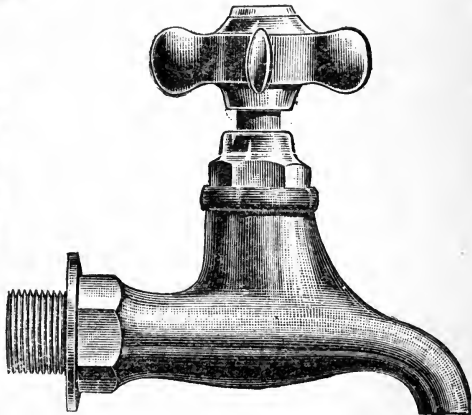

FIG. 333.—Kelvin flanged bib tap.

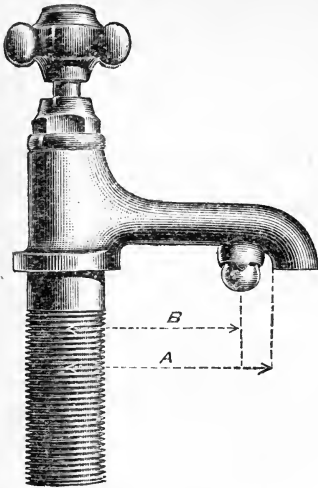

FIG. 334.—Kelvin pillar tap for tip-up basin.

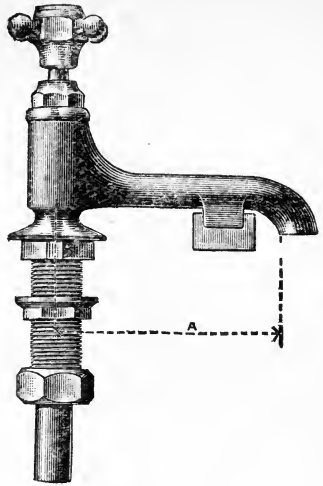

FIG. 335.—Kelvin tap for tip-up basin.

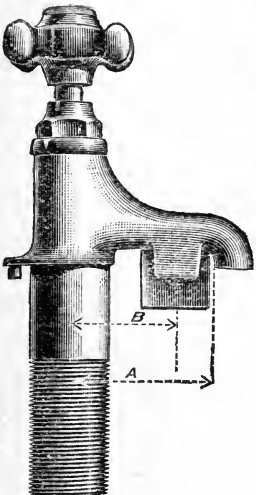

FIG. 336.—Kelvin tap for tip-up basin.

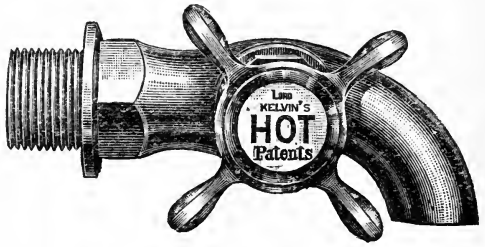

FIG. 337.—Kelvin tap for butler's pantry.

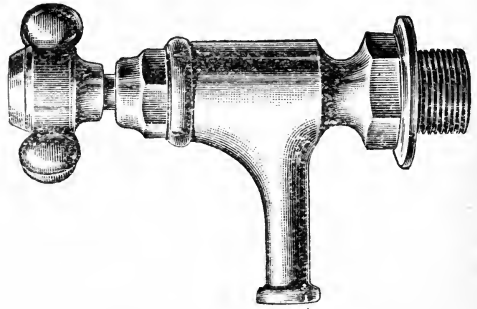

FIG. 338.—Kelvin tap for pantry trough.



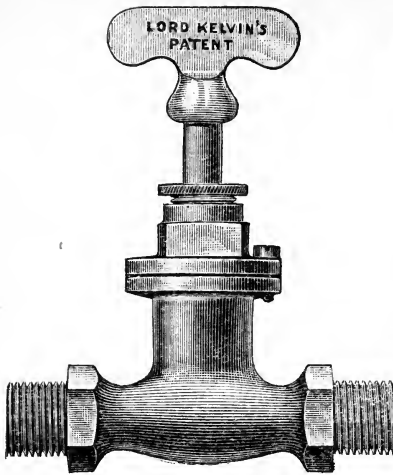

FIG. 339.—Kelvin stop tap.

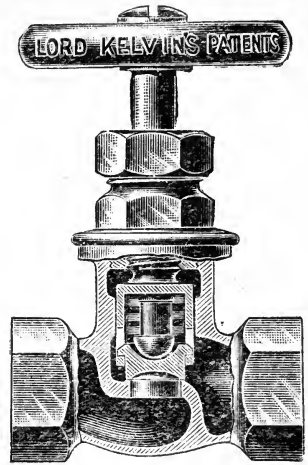

FIG. 340.—Kelvin steam tap.

Disinfectants for water-closets, soil-pipes, waste-pipes, and drains should never be required. Where air with its purifying action has free course, as it should have through all such concerns, disinfectants will generally be worse than useless, and should not be employed except under medical advice in some cases of infectious illness.

Chloralum may be used with advantage as a deodoriser in cases of illness, for deodorising and disinfecting excretions.

Hydrochloric acid, in twenty times its bulk of water, may be used as a disinfectant in vessels where typhoid fever excretion is discharged.

Carbolic acid is the best rough-and-ready disinfectant for drains, cesspools, etc.

Theocamf is a new disinfectant, which, on the authority of Dr. J. Emerson Reynolds, Professor of Chemistry in the University of Dublin, possesses properties superior to all other disinfectants. The basis is a liquid which results when

sulphur dioxide gas is brought in contact with camphor. It is effectual in disinfecting rooms, drains, excreta dejection, clothing, bedding, etc.

The advantages of fresh air flowing freely through every drain and pipe, and abundant ventilation in all closets and passages, will be sufficient to secure health and vitality in the household.

Let us remember that the question of sanitary internal appliances is of very great importance. Many of the odours attributed to the sewers proceed from dangerous and defective fittings. Sanitary appliances should be such as to fulfil as perfectly as possible the two objects of sanitary plumbing—

1. To remove all foul matter rapidly and completely from the house ;
2. To prevent the entrance of foul air from the drains into the house, so as to secure purity of air, purity of food, purity of water, purity of person, and purity of the habitation and of all its surroundings.

## CHAPTER VIII.

### WATER SUPPLY.

WATER, named by chemists protoxide of hydrogen (its symbol,  $\text{OH}_2$ ; its equivalent number, 18), is known to plumbers practically in three distinct physical conditions: as solid, in ice, when it suddenly expands with resistless force before it reaches  $32^\circ$  F., or zero C., and bursts the pipes and cisterns containing it; as liquid, in water, whether clear, transparent, colourless, and pure, for drinking and domestic uses, or acting as the carrier of the sewage from dwellings; as gaseous, in steam, when it passes  $212^\circ$  F., or  $100^\circ$  C., expanding enormously in bulk, and, when guided and restrained, doing a vast amount of work for the benefit of mankind.

Water consists of two volumes of hydrogen and one volume of oxygen gas, or, by weight, 11.11 per cent. of hydrogen and 88.88 per cent. of oxygen, oxygen gas being sixteen times heavier than hydrogen. In water these two gases are chemically combined; they lose their properties as gases and become a new substance.

Water has such great power of dissolving substances and absorbing them, that it is never met with in nature absolutely pure.

It is difficult to render water by any means absolutely pure. Even if water pure enough for domestic use is obtained, it is not easy to preserve it in a pure state, owing to its tendency to absorb all impurities in contact with it.

The source of all water supply may fairly be traced back to the ocean and the clouds. A rough average of thirty inches deep of rain falls annually in England.

QUANTITY OF RAIN-WATER FLOWING FROM ROOFS OR SURFACES FOR EVERY THOUSAND SUPERFICIAL FEET.

Rainfall per hour	. . .	1 inch.	$\frac{1}{2}$ inch.	$\frac{1}{4}$ inch.	$\frac{1}{8}$ inch.
Gallons per minute	. . .	9	$4\frac{1}{2}$	$2\frac{1}{2}$	$1\frac{1}{2}$
Rainfall per twenty-four hours	. . .	1 inch.	$\frac{1}{2}$ inch.	$\frac{1}{4}$ inch.	$\frac{1}{8}$ inch.
Gallons per hour	. . .	22	11	$5\frac{1}{2}$	3

The greatest extraordinary rainfall within a certain limited number of minutes has been found, after careful observation, as follows:—

Time of Fall.	Possible Amount. Inches.	Rate per Hour. Inches.
1 minute . . . . .	. '2 . . . . .	. 12
5 minutes . . . . .	. '75 . . . . .	. 9
$\frac{1}{4}$ hour . . . . .	. 1 . . . . .	. 4
$\frac{1}{2}$ „ . . . . .	. 1·8 . . . . .	. 3·6
1 „ . . . . .	. 3·25 . . . . .	. 3·25
2 hours . . . . .	. 3·6 . . . . .	. 1·8
3 „ . . . . .	. 4 . . . . .	. 1·33

We see by this table that sudden rain-storms of short duration may discharge enormous volumes of water in a few minutes, complicating the question of storage, and rendering the collection of the entire rainfall very difficult in country mansions.

The consumption of water goes on continuously, rather increasing in dry weather, when supply falls short. A month or two may occur when no rain falls, and then a storm of a few hours or minutes may fill all tanks to overflow and waste.

In making arrangements for the water supply of country houses, dependent solely on the direct rainfall, plumbers must ascertain the actual rainfall of the district for a series of years, because the average of 30 inches lies between the

distant extremes of 65 inches in Cumberland and 25 inches in London, in some districts as low as 15 inches in dry years.

The actual rainfall may be ascertained in any district by means of rain-gauges. These are made in various forms, the simplest being a metal cylinder with a glass tube rising outside from the bottom, divided into inches. The cylinder is covered by a funnel, to prevent evaporation. The depth of the rainfall is read off direct from the water level shown in the glass tube.

An objection to this form arises, namely, that the glass tube may burst in frosty weather. A float, with a graduated scale attached, rising with the water level, is sometimes used in preference.

The gauge adopted by Mr. Symons, the well-known meteorologist, consists of a cylinder, which receives the rain, and a small glass vessel with a graduated scale, in which the amount of rain collected is accurately indicated.

Costly self-registering rain-gauges are also constructed, and are used in all well-appointed observatories.

The plumber should be acquainted with the forms of these instruments, in the event of his practice extending to the colonies or foreign lands; but in practice in England they will not be required, as he will find accurate tables of rainfall published by Mr. Symons.

The results of extended observations in any part of the United Kingdom may be obtained at a very small cost, thanks to the efforts of that persevering meteorologist.

One inch of rainfall yields 22,622 gallons per acre; 32 inches, therefore, yields 723,904 gallons per acre. Something near one-half of this quantity is lost by evaporation; the other half sinks into the soil, and becomes available for the supply of wells, streams, and reservoirs.

Rainfall upon slated roofs may be rapidly stored, so that loss from evaporation shall be at a minimum.

The plumber will have to consider rainfall mainly in connection with house supply; he will ascertain the amount of roof surface available for collecting the rain, any hard clean surfaces of yards and areas may also be utilised to fill underground tanks for such purposes as the washing of carriages, laundry work, etc.; but this water would not be safe to use for drinking or cooking, nor should any risks be allowed of such water getting at any time mixed with the general water supply of the dwelling.

In supplying a house exclusively with rain-water, every available gallon should be safely stored, but this arrangement involves very large storage tanks.

Assuming the fall to be thirty-six inches, and supposing the fall to occur regularly of three inches per month, then a moderate-sized reservoir would suffice. Practically, this regular fall never takes place; the fall will be found to be irregular, one month yielding no water, another month yielding six inches, and perhaps so much as three or four inches falling in two or three days. In order, therefore, to secure all this rainfall, the storage space must be large enough to retain all the storm water, for if any be lost through overflow, it cannot be recovered.

Assuming the area of the roofs of an ordinary country house with its out-offices to be two thousand square feet, available for the collection of the rainfall, measuring the flat plan of the house from out to out of the eaves (not the more extended area offered by the slope of the roofs), we may roughly find the number of gallons by multiplying the area in square feet by half of the rainfall in inches. The product gives in this instance  $2,000 \times 18 = 36,000$  gallons a year, supposing that every gallon is secured, and not

making any allowance for loss, evaporation, storm overflow of storage tanks, etc. It will not be safe to calculate on storing more than half this amount for use = say 18,000 gallons. For this purpose the storage tank should measure 18 feet  $\times$  8 feet  $\times$  5 feet deep = 4,500 gallons, or for one-fourth of the total annual amount calculated. If such extensive storage can be provided, there is no doubt that the rain-water caught by the roofs and yard surfaces of an ordinary country house may be collected in sufficient quantity for an efficient and economically restricted supply for all domestic purposes throughout the year, while it will be also desirable to supplement the supply from other sources in the event of an unusually dry year.

Devices for separating impure from pure roof waters are ingenious, but liable to go out of order from frost and neglect; they send a quantity of the water away to waste, they have been much admired as ingenious contrivances, but they require too much attention to be of practical value. Plumbers should examine these and all such novel contrivances, and test them at work, considering carefully the purposes they are intended to fulfil, and also the difficulties and special obstacles, such as frost, floods, dirt, corrosion, wear and tear, exposure to sun, rain, heat, or cold; endeavouring to picture to his mind these points, and how far the apparatus or appliance in question is likely to meet them, not alone when first fixed, but in five or ten years after.

Rain-water approaches nearest to purity after a continuance of wet weather, yet it always contains atmospheric air, and such gases as may be present in the air. After a spell of dry weather the first rain-water from roof surfaces contains traces of nitrates, nitrites, ammoniac salts, often of common salt and other impurities; but the chief dangers

of rain-water impurity arise from the defective arrangements for storage adopted, where the overflows of tanks communicate with foul drains and cesspools, where organic impurities are not rigidly excluded, and where means for periodic cleansing of the storage tanks are not provided.

Spring waters always contain saline matters dissolved, the nature of the salts depending on the strata of the ground in which the spring appears.

In these waters calcic carbonates and sulphates are the usual impurities, also magnesian carbonates and sulphates, and common salt.

New red sandstone waters contain sulphate, and so does the water of shallow wells, mixed with other impurities.

In London gravel nitrates and ammoniac salts from sewage contamination are often found in shallow-well water. The contamination of shallow wells varies so much at different times, that an analysis taken at any one time does not afford a reliable test of the average quality. With deep wells the contrary result obtains, and analytic tests are fairly reliable. Such waters are generally good and pure.

Most spring waters contain carbonic acid, which dissolves much calcic carbonate. There is no actual proof of injury to health caused by this lime impurity in waters.

River waters in this thickly-populated country are unfit for drinking, or even for cooking purposes, being invariably more or less polluted with sewage. The smallest amount of sewage renders such waters unsafe, and at certain times extremely dangerous. One typhoid-fever patient on the banks of a river might so foul the stream that the disease would be communicated to thousands of healthy persons.

Waters are known as hard or soft, according to their action on soap. Calcium and magnesium compounds in hard



water cause it to curdle soap; while soft water, on the contrary, dissolves soap freely. It has been stated authoritatively that the substitution of the Loch Katrine water, of one and a half degree hardness, for the water of eight degrees hardness formerly supplied to Glasgow, caused a saving to the inhabitants of that city of 2s. per head, or about £36,000 per annum in the item of the washing soap alone.

The hardness of water is measured in degrees. One degree of hardness signifies that one gallon of the water contains one grain of carbonate of lime or chalk; if the hardness be due to other salts, it is reckoned as being equal to a proportionate amount of chalk. Thus, water of six degrees of hardness means that it would waste as much soap as six grains of chalk dissolved in the water would waste. Every grain of chalk, or, in other words, every degree of hardness, destroys or curdles eight grains of soap before a lather can be produced; these eight grains are therefore wasted, and this provides a measure whereby we may estimate and define the extent of hardness in any water. Some kinds of hard water are capable of being rendered soft by boiling. These are termed waters of temporary or removable hardness; while other kinds, incapable of alteration by boiling, are termed permanently hard waters.

Permanent hardness is produced by calcic and magnesian *sulphates*, etc., which cannot be eliminated by boiling. Temporary hardness is produced by calcic and magnesian *carbonates*, which salts are freely soluble in waters containing carbonic acid. When the process of hard boiling for some time expels this carbonic acid, the water can no longer contain the calcic and magnesian carbonates in solution. They are, therefore, then precipitated as a powder, and they form a strongly adhesive fur or incrustation on the boiler, which often causes trouble to the plumber. If calcic sulphate be in the water, a portion of it is also deposited.

The carbonic acid in the water, which holds these salts in solution, can also be removed by the addition of a certain small proportion of lime water, which absorbs the carbonic acid, so that both the lime dissolved in the water and that in the added lime water are precipitated together as calcic carbonate. This softening process, known as Dr. Clarke's, is of great value, and is successfully applied on large and small scales to waters containing much calcic carbonate or carbonate of lime in solution; but it is only applicable to waters of temporary hardness.

This deposit of lime in boilers is a very serious matter. As it increases in thickness, the iron plates of the boiler become separated from water contact, causing the water to heat more slowly, till at last a stronger fire than usual must be applied. The iron plates become red hot, expanding so as to crack the layer of rigid lime incrustation; a split occurs in the lime, and water rushes in on the red-hot plate, suddenly cooling the outer edges of the red-hot area, which edges, in contracting, force outward the softened hotter central portion of the area, and forming the blister we so frequently see on boilers where a leakage has occurred. Probably there is also a sudden force or pressure generated at the moment of contact of water with the red-hot plate, which cracks the iron plate across the blister outward.

Water must be boiled for a considerable time, and the ebullition must be very strong, in order to expel the carbonic acid gas in sufficient quantity to reduce the hardness naturally by causing a large deposit of lime.

Plumbers may, therefore, learn the useful lesson that, when compelled to supply very hard water to kitchen and bath boilers, they should so plan their system, either by reducing the power of the fire on the boiler, or by using extra large hot-water circulating cisterns, that the water

should never reach boiling-point. By this means the deposit of lime may be materially reduced. It is only when boilers boil and bubble that the hard incrustation deposits rapidly; such waters are almost useless, therefore, in steam boilers. Special care must also be taken in these cases to provide ready and ample means for cleaning the interior of boilers and pipes. A defined period for cleaning them should be fixed on, according to the hardness of the water. Every boiler should be opened and cleaned at least once every year; some need this operation every quarter, if incrustation forms rapidly.

The report of the River Pollution Commissioners classifies several waters in this order as regards their hardness: 1. Rain-water (softest). 2. Upland surface water. 3. Surface water from cultivated land. 4. Polluted river water. 5. Spring water. 6. Deep-well water. 7. Shallow-well water (hardest).

They consider waters soft which are under six degrees of hardness. They classify several waters in this order as regards quality: 1. Spring waters. 2. Deep-well waters. 3. Upland surface waters = wholesome. 4. Stored rain waters. 5. Surface waters from cultivated land = suspicious. 6. Polluted river waters. 7. Shallow-well waters = dangerous. They consider spring and deep-well waters the best and of inestimable value, and worthy of great efforts to secure and preserve for use.

Plumbers should treasure in their minds these results of scientific inquiry and laborious research, and be in a position to give reliable advice when their advice is asked for.

Testing water for impurities does not come within the plumber's sphere, nor is it to be desired that so important

a question as the quality of a water for household purposes should be settled by any but a skilled analytical chemist.

Simple tests, which can be used in a preliminary fashion to detect suspicious appearances in water, may sometimes prove serviceable, such as simple tests for lead, zinc, iron, copper, and even sewage impurities.

The simple preliminary tests which may be taken to cause or establish suspicions of certain impurities in waters should not be considered as finally determining water quality for domestic purposes.

For sewage impurities in water—

Take permanganate of potash or Condy's fluid, which communicates a bright violet-rose colour to the water when added. Take a glass of the water, and add four drops of permanganate, allowing it to stand two hours.

The rose colour will change to dull yellow if decomposed organic matter be present in dangerous amount.

The rose colour will in time disappear completely if there be a very large quantity of dangerous matter present.

The rose colour will turn paler, but retain a decided red tinge, when some, but not an immediately dangerous, amount of organic impurity is present.

If the changes indicating impurity occur sooner than in two hours, the quicker and more decided the discoloration the greater the quantity of decomposing organic matter present.

For lead impurity (acetate of lead)—

Take sulphide of ammonium, and add six drops to a small glass of water.

The water will turn black if lead be largely present, but it will also turn black if other metals, such as iron, mercury, silver, etc., be present; so to localise lead a second test is desirable.

Take chromate of potassium, and add four drops to a small glass of the water.

The colour will turn yellow if lead be present; it will also turn yellow if barium be present. This ingredient is both rare and harmless; it is not likely to be met with.

Both tests indicating lead as above, it may fairly be taken as probable that the water is contaminated by lead.

Take sulphuric acid, and add six drops to a small glass of water; it will give a white precipitate if lead be present, soluble in caustic potash.

Lead steeped for some hours in water, even in distilled or pure water, which naturally attacks lead, will not give a sufficient quantity of lead in solution to show any effect from chemical reagents to a class in the lecture-room, unless you evaporate the water to about one-twentieth of its bulk. But it should not be forgotten that the effects of lead poisoning are cumulative; they remain in the system and accumulate there.

Sir Charles A. Cameron on one occasion desired a delicate test to detect lead in the water contained in a lead cistern. All ordinary tests failed, so he placed some small fishes in the water and watched their movements. After some time their bodies became cramped into a curve, so that they could no longer swim in straight lines, and when darting at their food they invariably missed the mark, owing to this effect of the lead poisoning; the fishes passed such quantities of the water through their gills that the cumulative effect of the poison was made apparent.

The presence of chlorinè (chloride of sodium, or salt) in well waters, found in inland places where natural deposits of salt do not exist, is almost certain proof of sewage contamination.

Waters of this class can be detected by nitrate of silver, which throws down a white deposit.

Add a little ammonia, and the white deposit vanishes, for it is soluble in ammonia.

Of course the presence of salt or chlorine in well waters *near the sea* cannot be taken to prove sewage contamination.

For zinc impurity (sulphate of zinc)—

Take ferrocyanide of potassium, and add six drops to a small glass of the water.

The colour will turn green if zinc be present.

And, again—

Take sulphide of ammonium, and add six drops to another small glass of the water.

The colour will turn white by a white precipitate falling.

For copper impurity (copper chloride, blue vitriol)—

Take common ammonia, and add eight drops to a small glass of the water.

The colour will turn light and dark blue if copper be present; or bright steel dipped in copper-tainted water will turn copper coloured.

Take ferrocyanide of potassium, and add eight drops to a small glass of the water.

The water will turn chocolate colour if copper be present.

For iron impurity (chloride of iron)—

Take ferrocyanide of potassium, and add twelve drops to a small glass of the water.

The colour of dark Prussian blue will appear if iron is present.

Let me again repeat that the definitive, decisive testing of potable waters is and should remain beyond the scope of plumber's work.

The physical characteristics of good water may form some guide to a decision on its quality. It should be clear, without sediment or suspended particles; colourless, or slightly bluish if deep, yellow or brown water being suspicious, unless coloured by peat or iron; bright and sparkling, full of air and carbonic acid; pleasant to taste, not brackish, free from odour, and dissolving soap easily.

These qualities should appear in wholesome waters, and render the chances of its really being so very favourable.

This will be the proper place in which to refer to the action of water on the metals used in pipes and tanks, lead and zinc.

Very small quantities of lead are sufficient, if repeatedly taken, to produce symptoms of poisoning. One-tenth of a grain per gallon is enough to affect most persons injuriously.

The purest waters, and those most aerated, unless containing a large amount of carbonic acid gas, have the greatest effect on lead.

The Dublin Vartry water and Glasgow Katrine waters are very pure and attack lead.

Again, water containing animal organic impurities, or containing nitrites or nitrates or chlorides, will attack lead.

But waters containing carbonates, chalk and lime waters, and, in a less degree, sulphates and phosphates, form a film on the metal which prevents further corrosion.

Sir Charles Cameron, the distinguished Chief Medical Officer of Health for Dublin, found that lead pipes and sheets, if alloyed with three per cent. of tin, were rendered proof against all lead action of the Dublin soft waters, and this alloyed lead pipe has been adopted and used for many years with safety.

Lead is specially liable to corrosion when attacked by water and air alternately, and this fact applies to all metals

which are corroded by water. Cisterns oftener give way when repeatedly filled and emptied from an aerating supply under pressure. The water should, therefore, always be maintained at one level in lead-lined cisterns. In cases also where waters are of a character likely to corrode lead, Dr. Christison recommended that the cistern be filled first with a weak solution of phosphate of soda, by which an insoluble protective film is formed on the lead.

Many kinds of spring and deep-well waters may be quite safely stored in lead cisterns and distributed in lead pipes. The chemical analyst should be employed to test the character of waters in the country before using lead extensively in contact with it.

Plumbers should gather the practical lesson from these statements that lead-lined covers should never be used for cisterns, especially for hot-water cisterns. The watery vapour or steam condenses on the lead, and with the combined action of the air rapidly corrodes the lead, and the water, dropping back into the cistern, carries with it measurable quantities of lead. Hot water acts strongly on lead, especially if distilled through lead pipes. It is dangerous, therefore, to use hot water for cooking purposes which has been circulating through leaden pipes and into leaden cisterns.

Composition lead pipes, used for gas and composed of scrap lead and antimonial lead, should never be employed to carry drinking water, hot or cold; it is a very dangerous practice.

Tin-lined lead pipes were recommended by many authorities, but have practical objections of their own, being difficult to bend and to joint satisfactorily.

The action of water upon lead is so frequently prevented or neutralised by the salts in solution in most waters, that the startling statements we see made must be somewhat



exaggerated. Care, however, should always be exercised to prevent all evil consequences.

Zinc dissolves in water at ordinary temperatures, especially in distilled waters, rain-waters, and waters containing carbonic acid. Hard waters, in which are salts of lime, exert but a slight action on zinc, which amounts to the simple deposit on the zinc of an insoluble film of hydrocarbonate of zinc, which stops further corrosion.

Authorities differ as to the extent of the injury caused to the system by zinc poisoning. But, on the report of a French Government commission appointed to inquire into the subject, the use of zinc-coated iron water tanks was prohibited in the French navy; and this decision is supported by many experiments on water passed through galvanised-iron piping by Dr. Frankland, Professor Heaton, and many others, with results showing very marked presence of zinc in the water.

In galvanised-iron cisterns and pipes the iron is coated with zinc, and to some extent alloyed with it—the two metals form a galvanic couple—so that, under the action of any exciting liquid, the zinc is attacked while the iron is protected.

We have all seen also how the zinc will scale off in cisterns, and how often the oxidation or rust of the iron comes through. So much so, that galvanising iron laundry boilers is of little use in preventing rust to clothes boiled in them, and hot cylinders and tanks are frequently found coated with rust inside, as if they had not been galvanised at all. The rust is sometimes transported to the cisterns from the iron boilers, but frequently it breaks out in the cisterns.

Zinc as a poison is very dangerous; therefore the use of it in vessels for water or food is open to grave question, and,

as in the case of lead, precautions should be taken to ascertain the quantity of water you bring in contact with zinc or zinc-coated iron.

Water for drinking ought not to be allowed to stand long in zinc or galvanised vessels. Sometimes the zinc is taken up by the water to such an extent that a disagreeable metallic taste is imparted to it.

The following statement, made by F. P. Venable, Ph.D., in the *Journal of the American Chemical Society*, is worthy of production here:—

“The increase in the use of galvanised iron, especially in the form of water tanks and pipes, has led to a reopening of the question as to the possible injurious effects from the use of such water. It is a matter of importance, then, to us how far our knowledge extends on this subject, and I will collect here all of the known facts, so far as I have been able to get at them. The so-called galvanised iron is, of course, nothing more than iron dipped in a bath of zinc, and so superficially coated with it, and, to a certain extent, alloyed with it. The character of the protection afforded the iron is galvanic (hence the name), the two metals forming a galvanic couple, so that under the action of any exciting liquid, the zinc, and not the iron, is attacked.

“That zinc dissolves in potable water has long been shown by the experiments of Boutigny, Schaeffèle, and Langonné. Distilled water and rain-water dissolve it more readily than hard water. Especially is water containing carbonic acid capable of this solvent action. So much may be taken up that the water becomes opalescent, and acquires a distinctly metallic taste. It seems that, by the action of water, hydrate and carbonate of zinc are gradually formed, and that this action is more rapid in the presence of certain saline matters, but is weakened by the presence of calcium salts.

“As to the injurious effect of such water, authorities differ. Fonssagrives has investigated the question, consulting the statistics of the French navy and the recorded experiments of others, adding, however, none of his own. The French Government had, before this, appointed a committee to make a special report on the subject, and the investigations of Roux, in 1865 and 1866, furnish evidence enough of possible injury to health from water stored in galvanised-iron tanks to lead to an order from the Minister of Marine prohibiting the use of such tanks on board ships of war. Boutigny attributed grave effects to the use of these zinc-containing waters, looking upon it as probably resulting in epilepsy. Fonssagrives, however, maintains that the zinc is not cumulative, and produces no bad effects unless taken in large doses. Doubt is thrown on this position, however, by the fact that his assertions as to the limited solubility of zinc in ordinary drinking water are not sustained by experiments. Without doubt such waters have been used for considerable length of time, and no injurious effects have been noticed. This may have been due, however, to the hardness of the water, and hence the small amount of zinc dissolved. Pappenheim states, in contradiction to the assertion of Fonssagrives, that zinc vessels are dangerous and must be carefully avoided. Dr. Osborne, of Bitterne, has frequently observed injurious effects from the use of waters impregnated with zinc. Dr. Stevenson has noticed the solvent action of water on galvanised iron, and states that probably its continued use would cause injury to health. He recommends as a convenient test for the presence of zinc in potable waters, the addition of potassium ferrocyanide to the filtered and acidulated water. Zinc gives a faint white cloud or a heavier precipitate when more is present. Dr. Frankland mentions a case of zinc poisoning where well water, containing much dissolved oxygen and

but little carbonic acid, was used after passing through galvanised-iron pipes. Professor Heaton has recorded the analysis of spring water in Wales, and a second analysis of the same water, after passing through half a mile of galvanised-iron pipe, showing that the water had taken up 6·41 grains of zinc carbonate per gallon. A similar instance of zinc-impregnated water has come under my own observation, and I append the analytical results. The water from a spring two hundred yards distant was brought by galvanised-iron pipes to a dwelling-house and there stored in a zinc-lined tank, which was painted with white lead. The water became somewhat turbid and metallic-tasting, and its use for drinking purposes was discontinued. Analyses were made after the pipes had been in use about a year. A somewhat full analysis of the spring water was made under my direction by Mr. J. C. Roberts. The analyses of water from the tank, and directly from the pipe, I carried out only so far as zinc, iron, and tests for lead were concerned. The results are calculated in grains per gallon of 231 cubic inches.

“Constituents of the water:—

	Grains.
Silica . . . . .	2·45
Lime . . . . .	·23
Magnesia . . . . .	·17
Alkalies . . . . .	·43
Chlorine . . . . .	·35
Sulphuric acid . . . . .	·19
Carbon dioxide (calculated) . . . . .	·45
Total residue on evaporation . . . . .	4·34

“The tank contained 4·48 grains of zinc carbonate per gallon, with a trace of iron, and no lead. Water from the pipe gave 4·29 grains of zinc carbonate per gallon and a trace of iron.

“It is evident, then, when the dangerous nature of zinc as a poison is taken into consideration, that the use of zinc-

coated vessels in connection with water, or any food-liquid, should be avoided."

But notwithstanding all this condemnation, galvanised-iron pipes and cisterns are and will continue to be generally used.

Copper is a metal strongly attacked by water, and copper exerts a poisonous action on the human system. Chlorides, as common salt, and ammonia compounds in water increase its action on copper, but sewage and urine are specially powerful in corroding copper pipes, etc., in contact with it. Copper is therefore a highly unsuitable material for soil-pipes and waste-pipes. Pure water has also a distinct action on copper, even if in contact with it for an hour or two. Copper should therefore always be well tinned when used in cisterns or pipes; indeed, well-tinned copper is the best and safest material for hot-water pipes and for soft-water tanks and pipes.

Tin is not injuriously attacked by water, and, but for its great expense, perhaps pure tin would be the best of all metals in cisterns and pipes for storage and distribution of pure water.

The quantity of water required for every person is set down at various amounts by different authorities. A flat sponge-bath would catch more rain-water in twelve months than an ordinary man could drink in that time, so that a famine of water need never be feared in these countries.

Plumbers, in providing supplies for households, whether from rainfall or otherwise, should aim at twenty gallons per head per day, and as much more as can be readily obtained.

Money is well spent when it can be spared in securing a supply of water to a house or to a city—not merely abundant, but superabundant.

The sources of supply are—1. Public water supply, which is generally the best of all. 2. Rainfall on roofs, intercepted and collected by simple gravitation in high-level tanks, can be distributed by gravitation also, thus saving all pumping labour. Water carefully collected and stored from such a source ought to be fairly good. 3. Rainfall on yard surface and on low or distant roofs, collected and conveyed by underground pipes to underground tanks, whence it may be pumped to the high-level cisterns, or, better still, be reserved for supply to laundry, garden, etc., on lower levels, and not used for drinking or cooking. 4. Pure streams, free

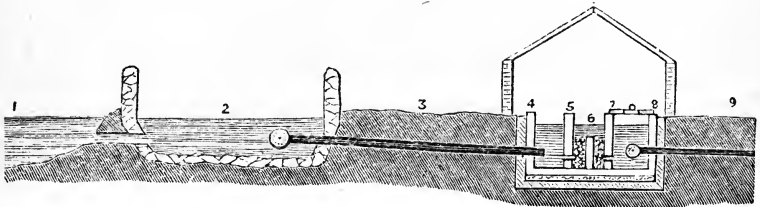

FIG. 341.—Filtering arrangement at head of water supply for river water. 3

from sewage contamination or cattle fouling, especially if running at a level and above the house, may by gravitation yield a constant safe supply, through proper filtering arrangements, for all household purposes save drinking. 5. Springs. 6. Deep wells; and 7. Shallow wells.

The best and simplest filtering arrangement for large supply consists of two tanks, one over the other, with a ball tap in each, so arranged that, when empty, water flows into upper tank, which has a perforated bottom and is half filled with animal charcoal. The water filters through this into the lower tank, and if the upper tank fills up by the water not filtering through rapidly enough, the ball tap in it closes and checks the further supply until water filters down; then the ball drops and opens the tap for a fresh charge, until at

last the lower tank becomes full, when the ball tap in it closes off the supply of water altogether, and the upper tank empties down, drawing air after it through the charcoal, and allowing the charcoal to become aerated and revived. This filter must be situated in pure air, and the charcoal

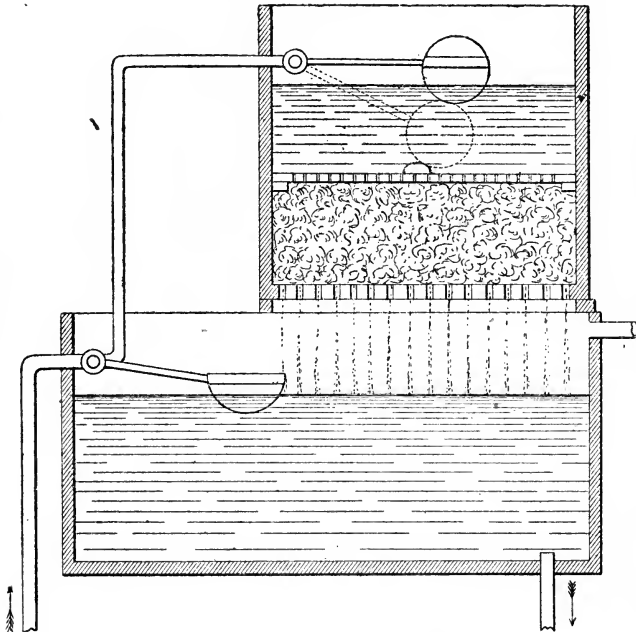

FIG. 342.—Aerating charcoal filter.

should be renewed every six months when fair water is used.

Charcoal filters having the charcoal, whether in block or powder, always under water unaerated and unrenewed, are worse than useless. In a short time they become a source of real danger, full of minute worms, and giving back to the water with interest and compound interest the impurities they arrested at first.

To raise water from tanks, wells, and other low-level sources the plumber's craft is required, and he is called on to advise what power shall be adopted for the purpose—whether manual power, horse power, water power, steam power, gas power, wind power, or hot-air power.

How is the required power to be measured? It is known that the famous horse, from whose performance this gauge was determined, exerted a steady pull of 150 pounds, 220 feet per minute, for eight hours a day, equal to 33,000 pounds raised one foot per minute. A man of ordinary strength exerts a steady pull of fifteen pounds under similar circumstances. As far, then, as regards mere strength one horse is worth ten men, or, in other words, one man-power is one-tenth of one horse-power. This is the estimate of Telford the engineer. It is usual, however, to estimate a horse-power definitely at 33,000 pounds raised per minute one foot high, and man's power one-seventh of that amount.

Some books of engineering formulæ give these figures for power required to raise water from deep wells:—

Diameter of Pump Barrel.	Description of Pump.	Quantity of Water raised per Hour.	Maximum Depth from which the Quantity can be raised by each Unit of Power.			
			One Man turning a Crank.	One Donkey working a Gear.	One Horse working a Gear.	One Horse-power Steam-engine.
Inches.		Gallons.	Feet.	Feet.	Feet.	Feet.
2	Double action	225	80	160	560	880
2½		360	50	100	350	550
3	lift and force pump.	520	35	70	245	385
3½		700	25	50	175	275
4		900	20	40	140	220

A gallon of water weighs ten pounds, so that the quantity of water raised one foot high per hour is, at a maximum, 198,000 gallons per horse-power, 28,286 gallons per man-power.

Mr. Bailey Denton has prepared a very useful table,



showing the best description of pump and power, and the time taken to raise different quantities of water from different depths to a uniform height of sixty feet above the ground. The table is worth noting carefully.

Depth of Water.	Quantity raised daily.	Description of Pump.			Character of Power to be employed.	Quantity raised per Hour.	Time to raise Total Quantity.
		Character.	Number of Barrels.	Length of Stroke.			
Feet.	Gallons.	Lift and Force.		Inches.		Gallons.	Hours.
25	250	2½ inches	1	6-9	1 man	170	1½
	1,000	3 "	2	7-9	2 men or donkey	340	3
	5,000	4 "	3	9-10	1 horse	1,000	5
	25,000	6 "	3	12-18	3-H.P. engine	5,000	5
	50,000	7½ "	3	18-21	4-H.P. "	10,000	5
60	250	2½ "	1	6-9	1 man	125	2
	1,000	3 "	2	9	1 donkey	500	2
	5,000	4 "	3	9-12	2 horses or	1,000	5
					2-H.P. engine	1,500	3½
	25,000	6 "	3	12-18	4-H.P. "	5,000	5
100	50,000	7½ "	3	18-21	6-H.P. "	10,000	5
	250	2½ "	1	7	1 man	100	2½
	1,000	3 "	3	9	1 horse	400	2½
	5,000	4 "	3	9 or 10	2 horses or	1,000	5
					2-H.P. engine	1,500	3½
200	25,000	6 "	3	12-18	6-H.P. "	5,000	5
	50,000	9 "	3	18	12-H.P. "	10,000	5
	1,000	3 "	3	9	2 horses or	400	2½
					2-H.P. "	800	1½
	5,000	4 "	3	9	2-H.P. "	1,000	5
300	25,000	6 "	3	15-18	8-H.P. "	5,000	5
	50,000	9 "	3	18	12-H.P. "	10,000	5
	1,000	3 "	3	12	2-H.P. "	700	1½
	5,000	4 "	3	12	4-H.P. "	1,500	3½
	25,000	6 "	3	15-18	8-H.P. "	4,000	6½
	50,000	9 "	3	18	14-H.P. "	7,200	7

No power, however great, can draw up water by suction from a greater depth than thirty-four feet, and even the accomplishment of that result would require perfect apparatus, with great power and a high barometric reading, indicating a maximum of atmospheric pressure. The practical limit of depth from which water can be advantageously drawn by a suction pump has been found in practice to be twenty-eight feet; the theoretical limit is

thirty-four feet. We have already learned, in our elementary study of aerometry, that the average pressure of the atmosphere on the surface of the globe at sea level is about fifteen pounds on each square inch, or, more exactly, 14.73 pounds when the mercury in the barometer stands at thirty inches. This column of air is capable of supporting or balancing in equilibrium a column of water thirty-four feet in height, or a column of mercury thirty inches high, as in the barometer.

If we take a hollow cylinder thirty-six feet high, fit it with a working piston absolutely tight and true, and place the bottom of this cylinder in a tank of water two feet deep, the piston being pressed down to the bottom of the cylinder, this will then represent the suction pipe and working barrel of a suction pump in a well. The water surrounds the bottom of the cylinder, but the cylinder is now full of air, which is pressing on top of the piston inside the cylinder, and also on the surface of the water outside in the tank, with an equal pressure of about fifteen pounds on every square inch. Now we raise the piston just two feet up to the level of the water in the tank, and the water of course follows the piston up the cylinder. So far the water would have risen of its own accord without any piston, on the principle of the equilibrium of liquids in connected vessels. We now continue to raise the piston, and the water continues to follow it until it attains up beyond about thirty feet above the level of the water in the tank, the water in the cylinder keeping nearly in contact with the piston, nearly touching its under surface, and at this elevation the water will stand. We see that it has risen and is balanced in the tube by the atmosphere pressing fifteen pounds on every square inch of water surface in tank or well. Continue now to raise the piston beyond this elevation and the water will no longer follow it, for the column of water has

reached the point where it is in equilibrium with the outer column of air. The normal pressure of the atmosphere should be increased in order to press the water any further up the tube after the piston.

Such is the principle of action in the suction pump, so called as it appears to suck the water up, whereas it really withdraws the pressure of the atmosphere from the surface of the water in the cylinder, and thus allows the outer pressure on the water in the tank to push the water up the cylinder after it. Remove the piston at the top of the cylinder, or make a hole in it, and the atmosphere will enter and press once again on the water in the cylinder, forcing it back into the tank.

The power necessary to raise and lower the piston is easily calculated. As the piston descends its valves open, consequently the only resistance met is the friction of the piston and the water; as the piston is raised the power required is measured by the weight of a column of water, the height from the surface of the water in well to the top level of the water raised, and its base the number of square inches in, or the area of, the piston.

If, for instance, the height of water from surface of well to delivery be twenty-eight feet, and the area of the piston be four square inches, the power necessary to raise the piston would be about sixty pounds, or fifteen pounds per square inch, due to the theoretical column of water when in equilibrium with the atmosphere.

The reason why the water cannot be drawn up more than twenty-eight feet in practice is that the vacuum formed must be imperfect, owing to unavoidable leakage between cylinder and piston and valves; the air compressed in the water also frees itself, and tends to prevent perfect vacuum when under a less pressure than usual.

The commonest descriptions of house pumps in use are known to the trade as shallow-well lift pumps, but they are really suction and lift pumps. They have two valves, one in the movable piston and one fixed at bottom of cylinder or working barrel. The water above the piston valve is lifted, and the water under it is sucked up; that is to say,

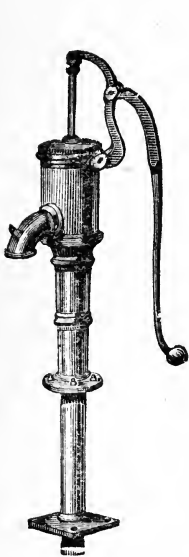

FIG. 343.—Independent lift pump.

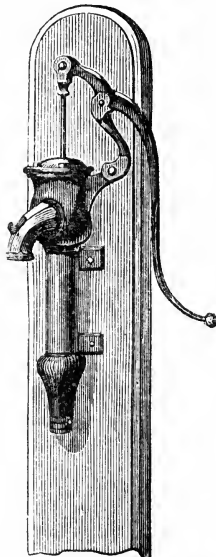

FIG. 344.—Lift pump on plank.

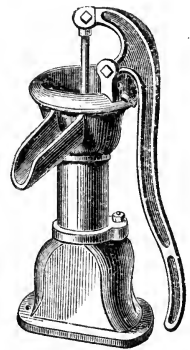

FIG. 345.—American pitcher pump.

These three forms are alike in principle, having two valves each.

a vacuum is created under the rising piston, which vacuum is instantly filled or supplied by the pressure of the atmosphere acting on the water surface of the well, and forcing the water to enter the vacuum caused by the rising piston. As the piston rises its valve is closed and the lower valve is open, and as the piston falls its valve is open and the lower valve is shut, so that the water can pass back into the suction pipe. This form of pump is calculated to raise

water to the pump level from shallow wells not exceeding twenty-eight feet in depth. If the well-water surface sinks lower than twenty-eight feet under ground surface these pumps are useless, and other forms must be used.

Other descriptions of common pumps are known as deep-well lift pumps. These also are really suction and lift pumps of similar construction to the shallow-well pumps with two valves, the point of difference being simply this—that, as the water will not follow a pump piston when that piston is more than twenty-eight feet above its level, the pump piston, with its cylinder or working barrel, is fixed down in

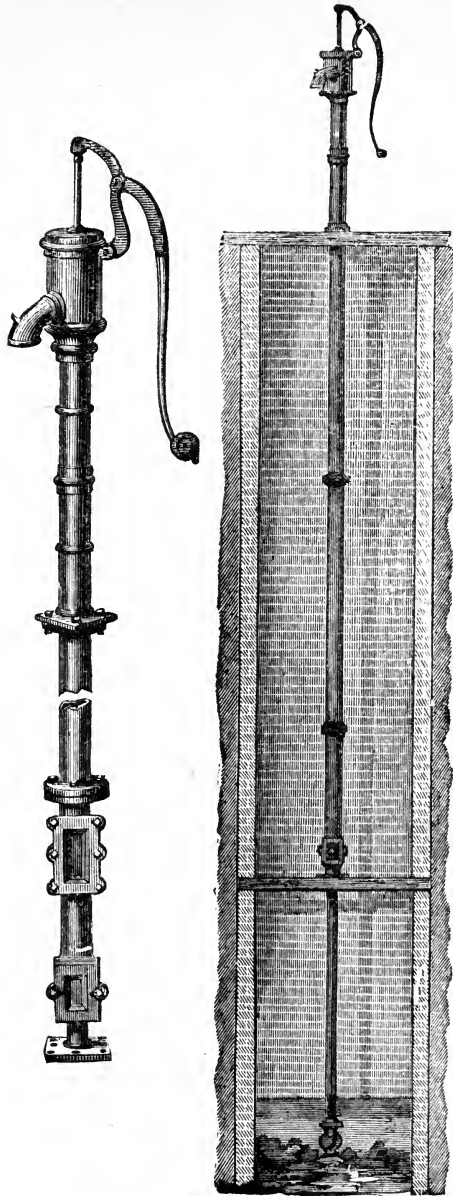

FIG. 346.—Illustrations of deep-well lift pump before and after being fixed in deep well.

the well, not further generally from the water's lowest level than twenty-five feet, the cylinder being connected with the pump by a continuous pipe, up through which the water is lifted by the piston when rising, and discharged at the pump head. A long rod passes through the rising-main pipe, connecting the piston in the working barrel with the lever handle in the pump head. These pumps require in all cases to be provided with well-arranged access doors at the working barrel portion in the well, so as to enable the valves to be got at for repair without removing the pump. These access doors are shown in the illustration (Fig. 346).

Force pumps, containing but two valves, are also made to force the water which has been raised into the cylinder up through the rising main by the downward thrust of the piston, which in this case is solid, without any valve in it. These pumps have given place to the suction and lift pumps illustrated on p. 395.

The combined suction and lift pump, or, as it is wrongly called, the lift and force pump, with three valves, is the form usually adopted for raising water to high level in country houses, where it may be stored in tanks, and distributed by gravitation as required.

In these pumps the cylinder or working barrel is generally made of cast brass, turned in a lathe, and fitted with a piston, having a valve arranged so that the water can pass through as the piston descends, but cannot return as the piston rises, and therefore is lifted the full height of the stroke; a second valve, also opening upward, is fixed at the base of the cylinder at its junction with the suction pipe; and a third valve, also opening upward, is fixed at the upper end of cylinder at base of rising main, which is simply for the purpose of supporting the column of water in the rising

main to prevent its constant pressure on the stuffing boxes of the cylinder and on the two working valves. As the piston rises at each stroke, the piston valve closes, and it performs two distinct operations. 1st. It creates a vacuum in the cylinder below it, into which the water in the suction

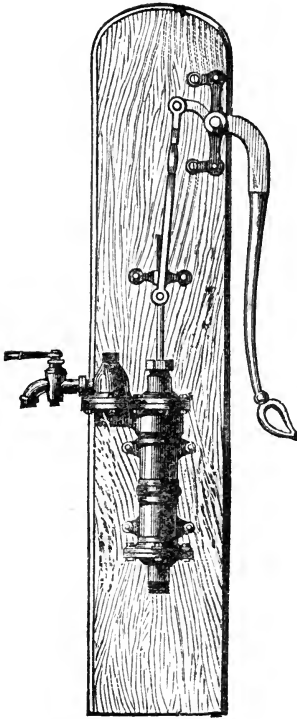

FIG. 347.—Lever pump.

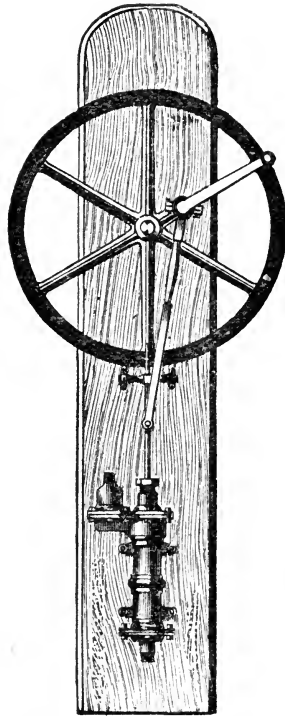

FIG. 348.—Wheel pump.

pipe rises, being pressed up after the piston by the pressure of the atmosphere on the surface of the well. 2nd. It lifts the column of water above it the height of the stroke, by the direct power of the stroke. When the upward stroke is completed the upper and lower valves close, preventing the return of any water above them, and the piston descends

through the water in the cylinder which passes through its now open valve. The pumping action would be the same if the upper valve was omitted, the bottom valve carrying the whole weight of the column, excepting during the up-stroke, when the closed valve of the piston carries the weight of the column.

This movement of the stroke in pumping would occur in sharp jerks, which would put unnecessary strain on the pump, the pipes, and on the man in pumping, and in order to ensure a continuous flow of water and relieve this jerking strain, an air-vessel of copper, lead, or iron is added, into which the force of the stroke drives the water, so as to compress the elastic air in it while the valve is open, and when the valve closes on the down-stroke, allowing time for the compressed air to expand again, while forcing the water upwards in a steady stream.

Then we have also in common use pumps for deep wells, called force pumps, which are also really suction and lift pumps, only that the working barrels or cylinders are fixed low down in the deep well, in order to be within twenty-eight feet of the water they are required to suck up. Within twenty-five or twenty feet would prove to be a more satisfactory suction. The pistons are actuated by iron rods from the surface, connected to levers or cranks, and the water is lifted in the usual way through rising-main pipes of suitable material and dimensions.

These iron rods are frequently fifty feet long, sometimes double that length in very deep wells; for whatever the case may be, the working barrels must be within twenty-eight feet of the water they are to raise, and in such circumstances the rods must be stayed and guided by rollers attached to iron staging carried across the well, as shown in Fig. 349.



Great care must be taken to fix these rollers so that the rods shall work absolutely free and plumb, else much labour will be added when pumping. The rising main is shown in this illustration, secured also to the cross-staging.

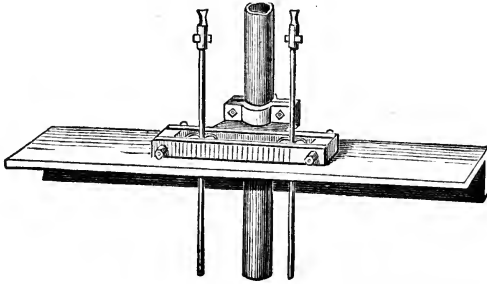

FIG. 349.—Cross-staging for pump well.

The following illustration (Fig. 350) shows such a deep-well pump, with metal frame and fly-wheel and crank-shaft on the surface, and with the working barrel, air-vessel, suction pipe, rising main, and rods supported on iron stagings down in the well. This is a single-barrel or single-throw pump, but in such cases it will generally prove more economical to use two or three working barrels with two or three rods and cranks, raising water through one suction pipe, and one air-vessel and rising main.

Such an arrangement, with three working barrels, driven by wind engine when sufficient breeze is blowing, and by horse-gearing when wind fails, has been frequently erected, as shown in Fig. 351. One fixed by the author to supply a small town has been successfully running for the last twenty years, and is working still.

Water-wheels are frequently used for driving pumps to raise water to considerable heights.

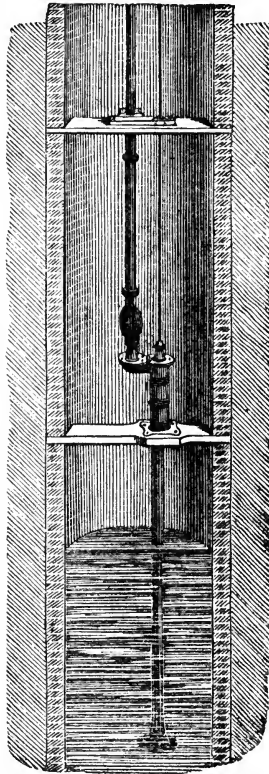
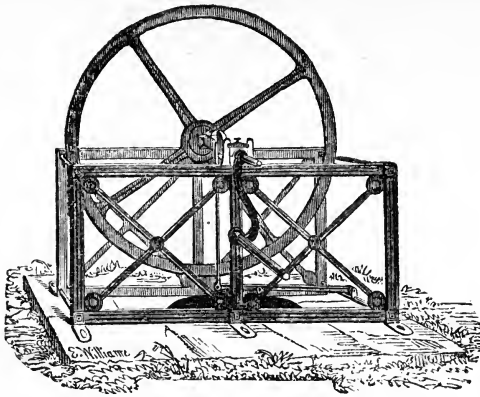

FIG. 350.—Deep-well pump and wheel-frame.

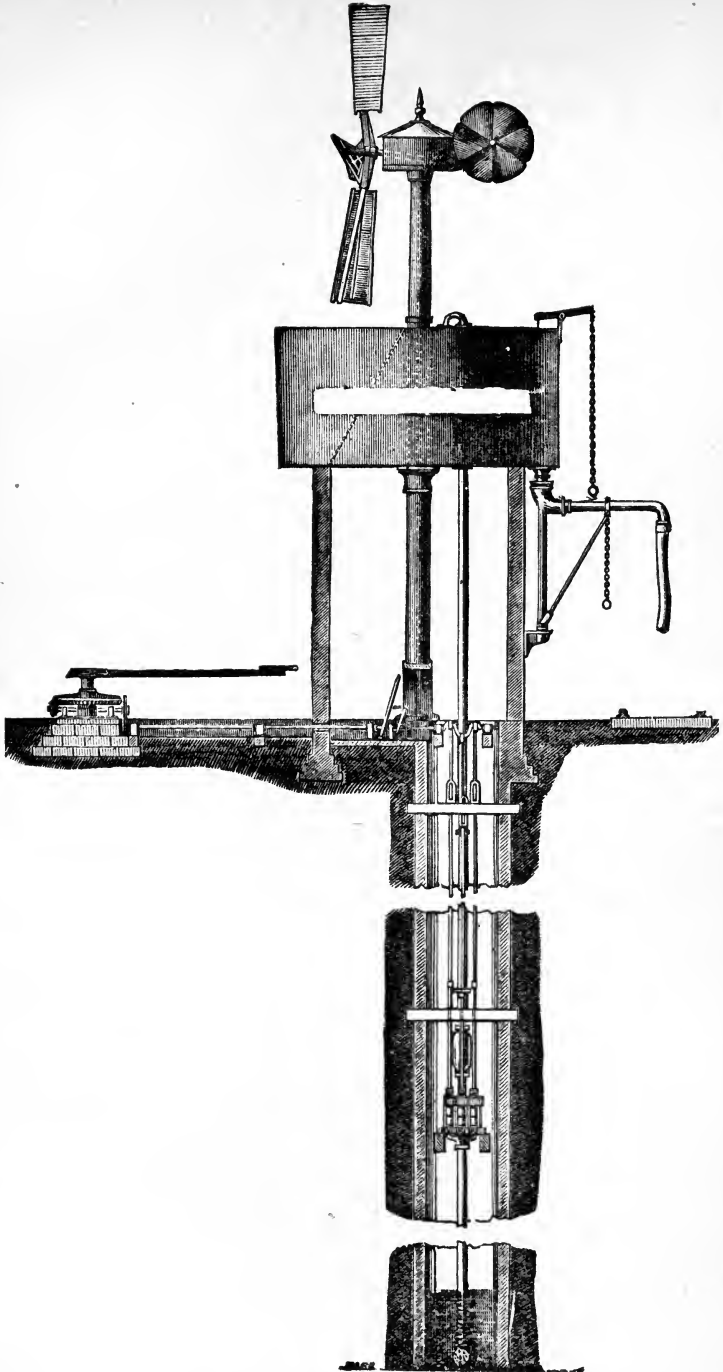

FIG. 351.—Wind engine and horse-gear pump.

They are constructed in many forms, the principal being undershot, breast, high breast, overshot, and turbine wheels. These, when well constructed, yield the following percentages of effective horse-power, the theoretical power being 1.

Undershot water-wheels . . .	·35	Overshot water-wheels . . .	·68
Breast water-wheels . . .	·55	Turbine water-wheels . . .	·70
High breast water-wheels . . .	·60	Hydraulic ram . . .	·60

The theoretical horse-power (HP) of any available water may be ascertained by multiplying the quantity of water flowing in cubic feet per minute (Q) by the head of water from tail-race in feet (W), and this product by the constant decimal number ·00189.

$$\text{Formula: } \text{HP} = \text{W} \times \text{Q} \times \cdot 00189.$$

The quantity of water in cubic feet per minute (Q), required to produce a given theoretical horse-power (HP), may be ascertained by multiplying the given horse-power (HP) by the constant number 528·5, and dividing the product by the head of the water from the tail-race in feet (W).

$$\text{Formula: } \text{Q} = \frac{\text{P} \times 528\cdot5}{\text{W}}$$

For raising large quantities of water, pumps with three or four barrels, in sets connected by wrought-iron cranks, should be used, driven by horse power, steam power, gas power, or water power in turbines and water-wheels. The details of each of these motors would occupy more than one such volume as this: we can only mention them, and pass on, saying that all pump-work down in wells requires to be done with special care. It is not pleasant work, nor, indeed, always safe work, and in deep-well work great attention should be expended on the ropes, windlass, ladders, and gear used for bringing the workmen and materials up and down. A careful, steady man should be stationed to guard the top,

never leaving his post or relaxing his care so long as a fellow-workman is down in the well. A small stone falling in accidentally might kill a man or maim him for life. But this work, if done at all, should be done substantially and with care and truth; the well will be closed in and the gear removed when the job is finished, and any defect or failure occurring through default in fixing or workmanship may cause great loss.

Wind engines will come more into use for raising water, and hot-air engines ought also to be better known; they are safe, simple, need no regular engineer to attend them, are noiseless, and cheap both in first cost and in fuel. The author has fixed both wind engines and hot-air engines which have been at work for very many years, raising water with the smallest possible need of repair.

The hydraulic ram for raising water gives excellent results when we have a fall of water sufficient in proportion to the height that the water must be raised, and when the quantity and quality of the water is up to the required standard; this useful engine is well worthy of a prominent place in our consideration.

Before you recommend the adoption of a ram for raising water, you require to ascertain the quantity of water at your disposal.

If a running stream be the source of supply, in order to gauge it you procure a straight flat board having a thin edge, and fix it at some convenient point across the stream, quite level and true, to act as a sill or waste board, so that every drop of water shall pass over with a free overfall and no obstruction. The depth of water passing over must then be carefully measured from the top of the sill to the level surface of the stream, before it begins to slope towards the weir,

and if the stream above the weir be not in rapid motion, then for each foot in width of sill the following depths of water will be found to discharge the number of gallons per hour specified:—

$\frac{1}{4}$ inch.	$\frac{1}{10}$ inch.	$\frac{1}{2}$ inch.	1 inch.	$1\frac{1}{2}$ inch.	2 inches.	Depth on sill.
260	300	650	1,900	3,600	5,400	Gallons per hour.

Multiplying these by the number of feet width of sill, the product will be the total quantity of water in gallons per hour at your disposal.

Gauging formulæ—

$$\left. \begin{aligned} C &= 214 \sqrt{H^3} \\ C &= 5.15 \sqrt{h^3} \end{aligned} \right\} \text{if water is still above weir.}$$

$$214 \sqrt{H^3 + .035V^2H^2} \text{ if in motion above weir.}$$

H = height over sill in feet.

h = height over sill in inches.

V = velocity of water in feet per second.

The formulæ used for gauging water over the weir, fixed as described across the stream, are simple when there is no perceptible motion in the stream above the weir.

C (the cubic feet per minute flowing over each foot width of the sill) is found by taking the square root of the cube of h (the height of water above the sill in inches) and multiplying that by 5.15; or by taking the square root of the cube of H (the height of water above the sill in feet) and multiplying that by 214.

If the stream approaches the weir with perceptible velocity, you must ascertain by experiment the rate of velocity in feet per second; then add the cube of H (the height in feet over the sill) to the product of the square of V (the velocity in feet per second) and the square of H (the height in feet over the sill) and a fixed number .035; find the square root of this sum, and multiply the square root by

214, and you have C (the cubic feet flowing per minute over each foot in width over the sill).

You next require to ascertain the minimum fall at command by careful levelling, and also the height to which you are required to drive the water, and you must carefully measure the distance from the position of the ram to the point of delivery; you must also find the quantity of water that you are required to deliver per day or hour.

Having found these particulars, you may not be satisfied with the fall at your command, and you must then see whether you can increase the fall by damming up the stream or by carrying your driving supply from a higher level of the stream, in earthenware pipes, to a small reservoir above the ram.

If you have not a sufficient constant supply of water in gallons to keep your ram always at work, you may be able to store sufficient to work for six or twelve hours, so as to send up all the water required, and you can arrange the ram in this case to stop and to start itself automatically, as the reservoir empties and fills.

Wherever a 3-feet fall can be obtained a ram may be worked, but of course the greater the fall applied the more powerful will be the ram, and the higher can the water be forced.

The proportion between water raised and water wasted is dependent on the relative height of the fall and delivery, and with a given fall the quantity of water delivered lessens in proportion to the height to which it is forced. The horizontal length of rising pipe and its diameter has also to be considered, owing to the effect of friction. When driving water one thousand feet, a good ram, well fixed, may be expected to raise one-seventh part of the water passing through the ram to four times the height of the fall, a four-

teenth part eight times, and a twenty-eighth part sixteen times the height of the fall.

Thus a ram with 8-feet fall will raise one gallon sixty-four feet, or two gallons thirty-two feet high, out of every fourteen gallons passing through the ram.

Rams can be made to raise water over 600 feet, delivering 200,000 gallons a day, and driving it two miles distance.

Rams are actually at work showing the following results daily: With 10-feet fall, 9,000 gallons are raised 150 feet, to a distance of 2,000 feet; with 8-feet fall, 6,000 gallons raised 130 feet, to a distance of 5,000 feet; with 6-feet fall, 10,000 gallons are raised 200 feet, to a distance of 800 feet.

In fixing hydraulic rams, the length of the injection pipe should be about the same as the height to which water must be forced, but certainly not less than three-fourths of that height, and its proper diameter may be found by multiplying the square root of the number of cubic feet of water used per minute by 1.45.

The best diameter for rising main may be found by multiplying the square root of the number of cubic feet of water used by the ram by .75.

The size of the air-vessel should be regulated in proportion to the contents of the rising main.

When you know Q (the quantity of water used in cubic feet per minute) and H (the head of water in feet), you may ascertain HP (the horse-power of your ram) by multiplying the product of both by the constant .00113—

$$HP = .00113QH.$$

When you know HP (the horse-power required), and multiply it by the constant 881, dividing the product by H



(the head of water in feet), you ascertain the quantity of water in cubic feet per minute which you must use—

$$Q = \frac{881HP}{H}$$

If you know  $Q$  (the quantity of water in cubic feet to be raised per minute) and  $H$  (the height in feet it is to be raised), you may calculate  $HP$  (the horse-power required) by multiplying the two amounts and the product by  $\cdot 0023$ —

$$HP = \cdot 0023HQ.$$

This applies, of course, to any engine or pump.

The hydraulic ram consists of a large air-vessel,  $F$ , having a valve,  $D$ , in the bottom, opening upwards, and the rising or

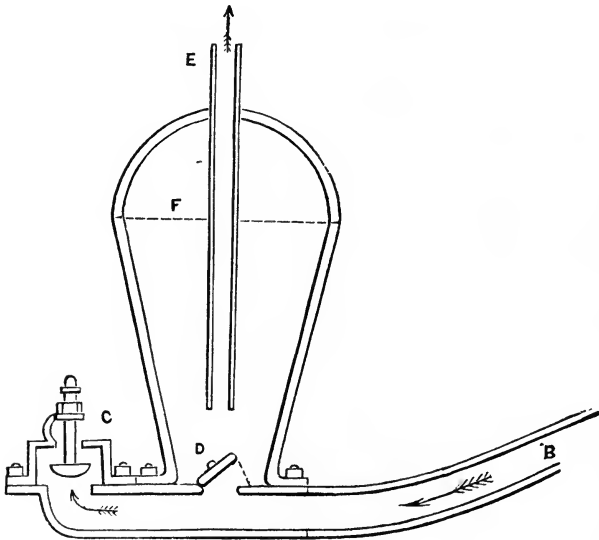

FIG. 352.—Section of American hydraulic ram.

delivery main pipe,  $E$ , leading freely out from the side or top, as illustrated. This air-vessel and valve is attached to the

extremity of an injection pipe, B, sloping from the reservoir, which reservoir gives the required head of water. Close to the air-vessel a second valve, C, is attached to the injection pipe or chamber, opening inwards and downwards. If we suppose the reservoir filled, and water allowed to enter and fill the injection pipe, it will rush down with sufficient velocity to close the lower escape-valve, C, and open the valve D, the water passing through D into the air-vessel and up the rising main until it reaches the level of the reservoir.

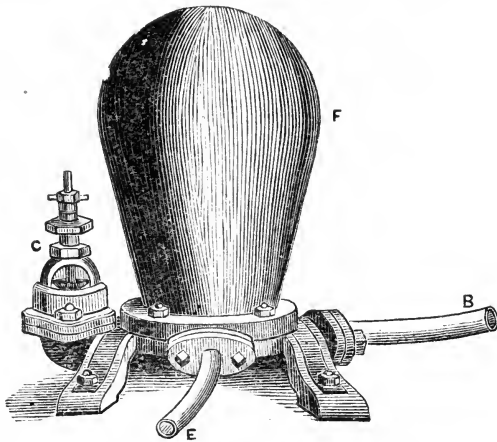

FIG. 353.—Elevation of American ram.

By the air now compressed in the air-vessel equilibrium is established, and the valve in air-vessel closes by its own weight. The escape-valve remains closed by the pressure of water from the reservoir behind it, but the object of the ram is to force the water in the rising main much higher than the level of the reservoir. How is this accomplished?

The equilibrium is at once disturbed by forcing down the escape-valve C against the pressure, and allowing some water free escape. As it escapes it gathers increasing force and momentum till it closes the escape-valve C with a sudden

shock; the recoil forces open the valve D into the air-vessel F, water rushes through, further compressing the elastic air in the air-vessel, till the equilibrium point is reached, when the air-vessel valve D closes by its weight, and the escape-valve C opens by its weight. The air in the air-vessel expanding, forces the water out of the air-vessel through the only outlet provided, viz. up the rising main E, towards the point of delivery, and the water in the injection pipe B again escapes through the foot-valve C with increasing velocity, until its speed is sufficient again to close the valve C, when the same effects are repeated and, stroke after stroke with regular beat, the water is pumped by its own momentum far above its level.

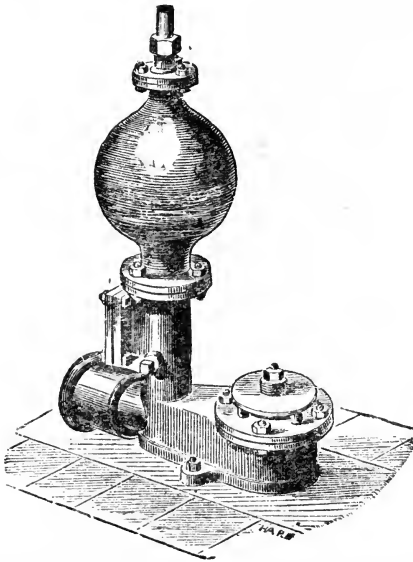

FIG. 354.—English hydraulic ram, single foot-valve.

It is well to fix a check valve on the rising main to prevent back pressure on the ram and emptying of rising main when the ram is not at work

A shifting valve must also be fixed at the base of the air-vessel under the valve to maintain the supply of air in the air-vessel, which would otherwise become exhausted. A

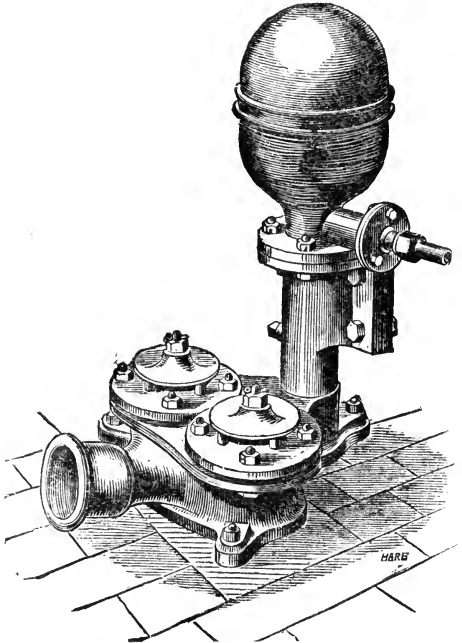

FIG. 355.—English hydraulic ram, double foot-valves.

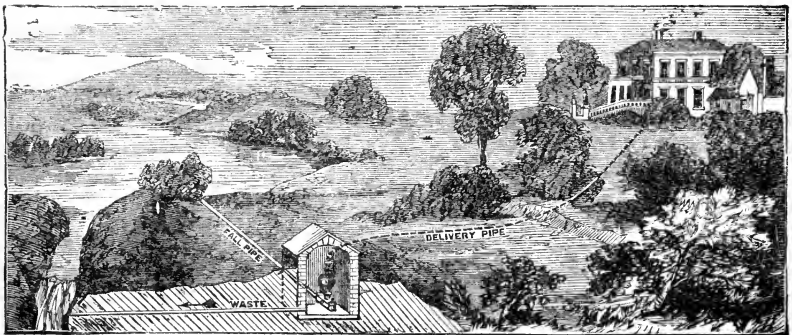

FIG. 356.—Arrangement of hydraulic ram and pipes.

vacuum is formed after each stroke, and a few bubbles of air are drawn in.

If the strokes make a loud noise, heard all along the pipes, and the machine is much shaken by the action, it is evident that the supply of air in the air-vessel is becoming exhausted, and unless it is replaced the ram will soon cease working.

The turbine designed by M. Fourneyron, of France, is a water-power wheel, encased in iron, widely used in France and Germany and America for mill work. In England the perfection of her steam-engines and the abundance of coal has resulted in the general adoption of steam power for driving machinery. Mill-driving work does not concern the plumber, but there are two instances, at least, when he may be called on to recommend the adoption of turbines to secure a water supply to mansions and villages.

In one case an abundant supply of pure water may exist at a level much below the position at which it is needed, and beside this pure supply there may also be found a very small stream of water, of doubtful purity, on a high level, available for the purpose of pumping the pure water from the low level to the mansion or village. The full height of the driving stream may be needed to give sufficient power to compensate for the smallness of its volume; in such a case a compound hydraulic ram might be subjected to so severe a strain that its valves could not stand the work, while the waste of water would be out of due proportion to the result.

Here the high-pressure turbine will be found the most suitable machine, utilising the greatest percentage of effect by driving three throw-pumps to raise the pure water to the desired position

In the other case a large volume of water in a river

may roll along at the foot of the mansion or village with but a slight fall, and here the low-pressure turbine may be employed, and render good service in driving pumps to raise water, either from the river itself or from some convenient pure source of supply.

The efficiency or useful effect of turbines is found in practice to differ greatly, even when the same size and design of turbine is made by the same maker. In Holyoke, Massachusetts, America, turbines can be tested individually for efficiency, but in this country we have no such public testing arrangements provided.

The efficiency or percentage of a turbine may be taken to mean the number of gallons of water it will pump back into a tank, in return for each hundred gallons drawn from the tank to drive the turbine. The results range from twenty-five gallons to ninety gallons returned out of each hundred gallons consumed; seventy gallons would be a fair working effect in practice.

Turbines are not affected or checked by back water, except so far as a loss of head is caused. Of course, when a turbine is submerged two feet under back water, two feet also must be deducted from the effective driving head.

It is an advantage for the lower part of a turbine to stand in the tail-water below it.

Cast iron is the material used in some of the best turbines ever produced; wrought iron is unsuitable; but the use of steel, brass, or bronze for joining the buckets appears to be a useless addition to cost, and should not be encouraged.

One of the advantages of a turbine wheel is that it occupies much less space than the undershot, breast, or overshot water-wheels; also it yields, when well constructed and fixed, a larger percentage of effect.

Wheels ten and twelve inches in diameter are largely used for driving machinery where the falls are great and the quantity of water available limited.

Wheels from forty-to eighty inches in diameter are made to suit low falls.

The turbine is generally constructed as a horizontal wheel. The driving water enters at the centre, diverging under the pressure due to the head by a series of curved guiding pockets in the fixed central portion, and escaping through a corresponding series of reversed curved buckets in the outer revolving portion of the wheel, impinging upon every portion, and driving the outer revolving circle with a pressure acting on every portion, as due to the head or fall. The efflux of the water is regulated by a hollow cylindrical sluice, having a number of stops, which act simultaneously between the guide-curves. These are all raised or lowered together by screws, communicating with a governor, which regulates the velocity of the turbine.

The water should enter the revolving buckets at a tangent, and press steadily against them, entering without shock or tremulous impulse, and leaving the wheel quietly when it has developed the best results.

The illustration (Fig. 357) represents the vortex turbine, which is arranged to work vertically, the driving axle shaft thus lying horizontal, and avoiding the need of tooth-wheel gearing. Portion of the driving head is derived from suction to tail-race below turbine. It is suitable for high falls, and may be located twenty-five feet above the tail-water, as the water, on leaving the turbine, passes by two pipes to the tail-race, utilising by suction power the whole fall below the turbine. This turbine is fixed on two beams, or girders, placed across the well over tail-race. The shaft

works through stuffing-boxes in the bends of the suction pipes, and the power may be taken direct off the pulley attached to the shaft. The supply pipes need not be vertical; they may enter the turbine case at the side by

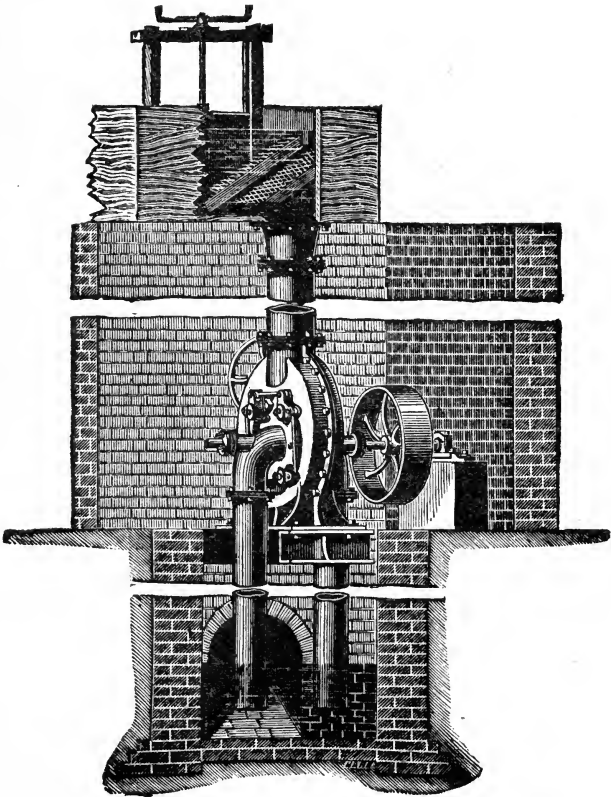

FIG. 357.—Vortex turbine arranged for high fall.

any convenient angle. An ordinary sluice-valve is placed on the pipe, generally at a point near the turbine case. The height of fall from surface of head to surface of tail-race, the quantity of water available, and the power or work required must be carefully ascertained before preparing plans.



We must now pass on to consider the question of water storage, which is a very important one, and deeply concerns the plumber.

There can be no question in town water supply between the merits of constant supply and the demerits and dangers of intermittent supply; the great evil of the latter being that, when water is shut off, foul air, foul germs, and foul

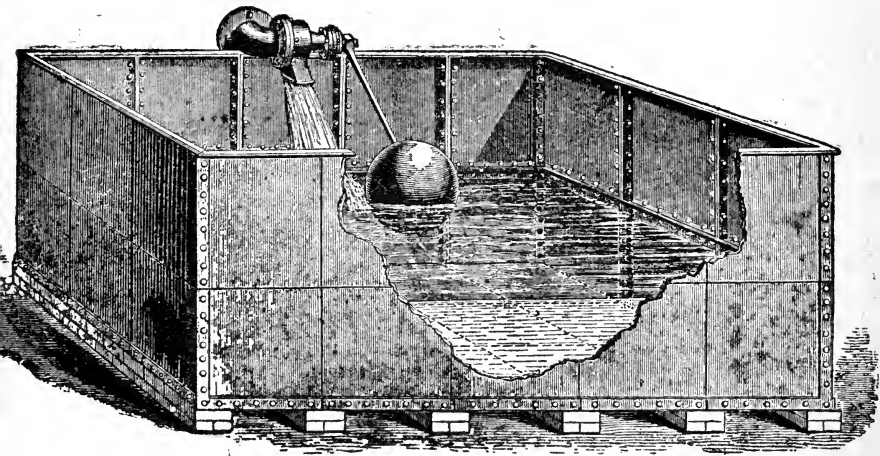

FIG. 358.—Cast-iron storage tank.

sewage even, may be drawn into the mains through defective pipes and open taps. The waste of water from leakages and defects has been proved to be greatly in excess of that occurring under a constant supply. Delay in getting water turned on if a fire occurs is a serious source of danger. The water cannot be used for motive power. The number of turncocks employed must be in excess. Cisterns must be provided to retain water, exposed often in unwholesome positions, and generally they are found on examination to contain filth. The very poor collect and keep the water

in unsuitable and dirty vessels in overcrowded rooms, where it becomes dangerous rapidly.

In the constant system in towns, cisterns and tanks are generally forbidden, except for boiler supply; but it will serve our purpose to include all methods of supply in our consideration of the question of storage, for even under the constant system it is well to have a reserve of water, always provided that it can be perfectly arranged, to maintain the water so stored pure and wholesome.

We must now assume that we have arranged an abundant and pure supply of water, and have brought it by the best means to the desired level in the main tank.

The position and surroundings of the tank are of great importance, both for the reputation of the plumber and the health of the household. A small, well-lighted, well-ventilated room should be reserved as a tank-room.

It should be secured from frost, fitted with a locked, air-tight door, to exclude the air of the house from the room; and it should be kept for the exclusive safe custody of the tank. Too often it is used as a housemaid's lumber and dust room.

The floor, walls, and ceiling should be made impervious to exclude doubtful air, and be glazed so as not to hold dust.

The floor should be lined with sheet lead, five or six pounds to the foot, turned up at sides, and with a 2-inch or 3-inch waste-pipe, ending in open air, with a copper flap-valve on to exclude air.

The tank should be raised on iron girders, eighteen inches over the floor, to allow easy access to the under side for repair or inspection and cleaning.

The tank should have an overflow-pipe large enough to take any water from accidental leakage of ball-cocks, if such

be used, or if supply-pipe be left open from a pumping engine; the overflow should be carried to a safe point to fill a flushing tank, or to serve as a warning-pipe. A proper arrangement for emptying tank easily for periodic cleaning should always be provided, taken from the lowest point in bottom of the tank to a safe point of discharge. It is very wrong for water companies to prevent this as some do. Large stand-pipe overflows and wastes, three inches or four inches in diameter, from high-level cisterns are not desirable, for the rush of water and consequent strain on fittings is generally too great, and may collapse the pipes.

The choice of the material of this tank should be decided by the quality of the water. If the water be of that kind which does not attack lead, the store tank may best be made of seasoned timber, planed smooth and dovetailed at corners, and lined with 7-lb. or 8-lb. sheet lead, or the sheet lead alloyed with three per cent. of tin.

If the water be liable to attack lead, then a cast-iron tank not galvanised will be the safest and best. Some authorities say that galvanised-iron tanks for storage should be avoided.

The Bower-Barff process of preserving iron has not borne the test in trials made by the author with welded wrought-iron range boilers in contact with Dublin Vartry waters, but it might prove more successful if applied to cast-iron tanks, and, if so, would be very useful for store tanks.

The process consists of heating the iron in a furnace to red heat, and admitting a jet of superheated high-pressure steam to play upon its surface, when a black magnetic oxide of iron is formed, which is said to be proof against further oxidation. The coating is very hard and brittle, and, if damaged, will of course have no effect. It hardens gun-barrel so much that it

cannot have screw-thread tapped on it until annealed, and the annealing injures the Barffing process.

Store tanks require monthly cleansing, whatever the material may be. The tanks are sometimes allowed to get into a disgusting and dangerous condition, because some waterworks authorities will not permit pipes to be taken from the bottom of tanks to empty them easily for cleansing purposes.

Overflows and wastes, when used, require great care in discharging their ends at a point where no foul or doubtful air can get back to contaminate the water in the store tank.

The size of the store tank should be very carefully considered and settled according to local circumstances; no fixed rule can be given. In suburban and country mansions the storage must be greater than in towns, and it can generally be arranged more safely also. Tanks had better be omitted altogether unless they can be rendered safe.

A downward distributing pipe is to be led from the tank direct to basement, and all branches to baths and auxiliary cisterns are to be taken from this pipe. Two or more main distributing pipes will be desirable in large mansions.

It is a good plan, where permitted, to affix a hose-screwed cock on this pipe at basement, and to provide hose and hand-pipe for cleaning windows and washing out corners in the basement passages and yards.

Stop-cocks may with advantage be placed on all draw-off pipes close to the store tank, to be shut off when repairs are needed on pipes or valves.

## CHAPTER IX.

### HOT-WATER SUPPLY.

THE hot-water supply, storage, and distribution require careful attention. An imperfectly arranged or constructed system is an endless source of trouble and expense.

Large quantities of very hot water are supplied in hotels and large mansions by means of a steam-boiler and closed iron or copper tanks, with coils of steam-pipes placed inside, the steam-coils being connected with the steam-boiler. The water heats rapidly, and can be drawn direct from the tank, or caused to circulate round the building to any positions where hot water is required.

This plan is sound and economical where the steam-boiler is required for other purposes, as heating, cooking, or pumping water, and as a proper attendant should be appointed for the care of steam-boiler and engine, the amount of work to be done by it should be sufficient to warrant the expense. Otherwise the hot water can be more economically supplied from an ordinary independent boiler on a metal base, or set in brickwork, the size and form being arranged after due consideration of the fuel to be used, the character of the water, and the quantity of hot water required.

Modern dwellings of moderate size will usually have a boot-shaped, welded, or riveted wrought-iron or copper boiler behind the kitchen range.

These boilers should be fitted with two manholes for

cleaning, one on the front above the skirting of the hot-plate of the range, well in view, and easily unscrewed, and the other on the top of the toe of the boot under the hot-plate, the hot-plate immediately over the boot being made to lie loose, without screws, and lift off, for easy access to the man-hole underneath, as the greatest amount of deposit takes place in the toe, which is actually in the blaze of the fire. It is usually in the toe that boilers give way and leak. The general cause of failure is that a coating forms inside, and is not properly removed. Lime waters sometimes are so strong that boilers need thorough clearing once in three months. Every range boiler needs cleaning at least once a year.

When boilers make a sharp, cracking noise, like a mallet struck quickly on iron, the cause will generally be traced to choking up of the flow or return pipes with deposit, and the noise gives wholesome warning of impending danger. When they make a thump, thump, thumping noise at odd times, which ceases when hot water is drawn off and replaced by cold, the cause is probably air in the boiler, from some defect in construction, or air in the pipes, from some defect in laying them.

Every high-pressure circulating boiler should be made so that no bubble of air can remain in it. The boot-boiler instep or top of toe should always slope well up towards the leg, and have the toe which lies in the fire well rounded. All parts should be rounded and corners avoided in boilers, especially where the fire plays on them. If the instep be flat, some inequality of inner surface or some change of level may afford a resting-place for air, which not only keeps water from contact with hot-plate of boiler, so that it burns out soon, but causes annoyance by noise and bubbling. The upper top of the boiler, though not actually in the fire, should also be flat and smooth, and care should be taken in setting to level it, so that every bubble of air shall flow easily

away up the flow-pipe, and to this end the flow-pipe must not project in the slightest degree below the inner surface of the top. To ensure no mistake on this point, it is a safe plan to screw down a flange socket on the top of boiler, screwed inside, to take the outflow pipe, and the hole in boiler to be drilled slightly smaller than this socket, so that the pipe cannot be screwed down through the boiler even by a careless workman.

For the same reason the outflow should be taken off the

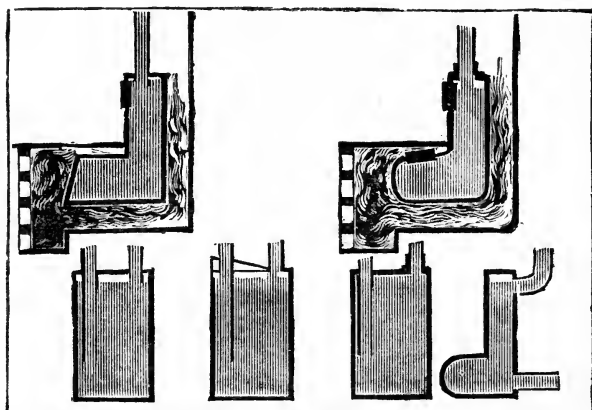

FIG. 359.—Common defects in boiler arrangement.

top of the boiler, not off the side or back, as it is almost impossible otherwise to avoid leaving a space for air.

The diagram will explain this.

The return pipe is generally more conveniently placed if led in through top of boiler at opposite end, and an inner prolonging pipe screwed on inside to carry return column of water down within six inches of bottom of boiler. The outlet and inlet pipes should be screwed in as wide apart as possible, to allow room for damper of flue between them.

For rain and soft waters boilers should have copper

pipes from boilers carried beyond reach of the flue heat, and here brass couplings hard-soldered to the copper at one side, and soft-soldered to lead pipes on upper side, may connect the circulating pipes, which are usually of lead, with the boiler. In some districts iron or tinned copper pipes are used for hot supply.

Every boiler should have a cleaning or emptying pipe taken from its lowest points, but arranged with stop-cock, having a screwed cap on its end, so as to prevent water being drawn off by servants, unless for cleaning the boiler when fire is out and boiler cold. No water for house use should be drawn direct from boiler.

An intermediate hot-water cistern, the cylinder being the best form for resisting pressure, and of a capacity proportioned to power of heating of the boiler and the wants of the household, may be fixed in a suitable position above the boiler. Copper cylinders are too often fixed of such light material that they collapse when cold water is turned on suddenly. Galvanised iron cylinders should be made with tops bolted on, otherwise the galvanising inside may be imperfect and the cylinder quickly fail from rust.

There are many elaborate systems of hot-water circulation, some complicated with valves, some with hot-water cisterns on same level as cold-water cisterns; but the simplest and safest system is that here described (we shall omit reference to other plans). If a linen closet be at hand on the basement, or not higher than the first floor, that will be the most useful place for the hot cylinder; winter and summer it will yield warmth to keep the linen dry and aired ready for use.

If the kitchen be lofty and airy, so that the heat from the cylinder in summer will not be too great, that position will suit well, because the scullery and kitchen hot-supply pipe must be always taken from the top of cylinder, and this



pipe will be thus shortened; but the heating powers of the cylinder, you observe, are here wasted always, and may be troublesome in summer. If there be a passage or staircase near at hand, perhaps the hot cylinder may be placed so as to utilise the heat in winter, casing it in during summer and conveying the heat away.

Hot cisterns are often hid away under roofs, where one has to scramble in darkness on hands and knees to examine and repair them, and where they are likely to remain without cleaning from year to year, till they wear out or leak. The repairs of cisterns and pipes in such positions occasionally result in the whole house being flooded or burned down. A case occurred where a plumber, from sheer laziness, when leaving off work, sent his lad to remove the tools from such a position, and the lad, following the example of his master's carelessness, set fire to the roof and to the house.

The hot cylinder should be placed above the boiler, in a position admitting of an even gradient for the circulating pipes. The best range of distance will be found between ten and thirty feet from boiler, not giving too long a pipe for circulation and its consequent friction. Hot cisterns should be tested to bear double the pressure due to the head of water from the cold-supply cistern. If 20-feet head, the pressure due is nine pounds per square inch; therefore the hot system should be tested to carry eighteen pounds per square inch at least, and for very strong work twenty-seven pounds per square inch. Every closed hot cistern should have a large cleaning door, or manhole, securely screwed down.

The pipes should be attached into strong screwed bosses with flanges affixed to the cistern before it is galvanised, so as to galvanise the bosses also. There are generally five bosses required—one on top for steam escape, expansion, and draw-off; two at the lower end of the side for circulating

pipes; one at the lower end of the opposite side for the cold supply; and one at the upper end of the side for basement draw-off pipe. Tinned copper cylinders are superior to galvanised-iron cylinders.

For ordinary houses the sizes of pipes are best arranged—1-inch circulating pipes, 1-inch draw-off and expansion pipe,  $\frac{3}{4}$ -inch draw-off pipe for basement, and  $1\frac{1}{4}$ -inch cold-supply pipe. To suit various requirements these dimensions may be enlarged or reduced, but the proportions may safely be followed.

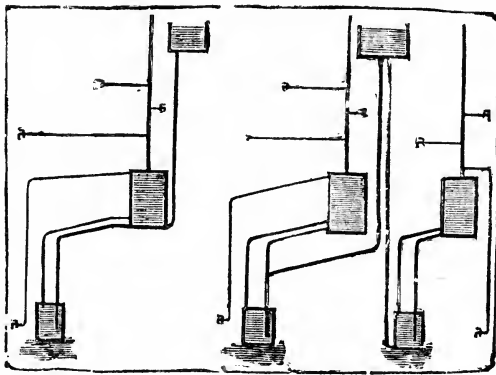

FIG. 360.—Three circulation systems.

There are many methods in use for bringing cold supply into the system—direct into the boiler, or branched into the return circulating pipe, or, as above indicated, into the intermediate hot cylinder. Cold water entering a hot boiler in contact with a blazing fire must injure the boiler by causing rapid contraction; by entering the return pipe with a soldered joint the joint constantly fails, owing to expansion and contraction of the metal. But when the cold supply is brought into the bottom of hot cylinder, opposite to the return pipe, so that cold water may flow across, mixing slightly with the bottom layer of hot water, so as to raise

the temperature before it enters the hot boiler, the cold water does not thus mix with the upper water of the cylinder, which can be drawn off at its hottest, when required.

The diagram shows three plans. All branch supplies of hot water may be taken from the expansion pipe, but sometimes a special draw-off pipe for basement hot water is provided with advantage direct from top of cylinder.

It is frequently desirable to induce a secondary system of hot-water circulation past the various hot-water draw-off taps over baths, etc., when such fittings are far from the cylinder, in order to secure an immediate supply of hot water at these distant points, and this is effected by carrying a  $\frac{1}{2}$ -inch return pipe from the ends of these hot branches back into the cylinder, or into the return circulating pipe between cylinder and boiler. The same arrangement can be made to act as means of preventing the cold-water pipes freezing up in winter, by carrying the hot pipes near the cold ones, though not in contact. Care should always be observed, in laying pipes hot and cold together, to separate them so that they may not both become hot by contiguity, or cause condensation of water outside on the cold pipes. In fitting hot-water supply pipes and cisterns there is room for the exercise of thought and skill. Very many badly devised and ill-constructed systems may be seen everywhere, and these fittings cause great discomfort when they fail.

Gravity is the cause of the circulation of heated water in pipes. The attraction of gravitation constantly and powerfully draws water and each atom composing its volume down towards the earth. When there are two columns of water in vertical tubes, joined above and below, so as to allow of circulation, they remain in equilibrium if the temperature of each column is alike. But when heat is applied so as to raise the temperature of one column, the

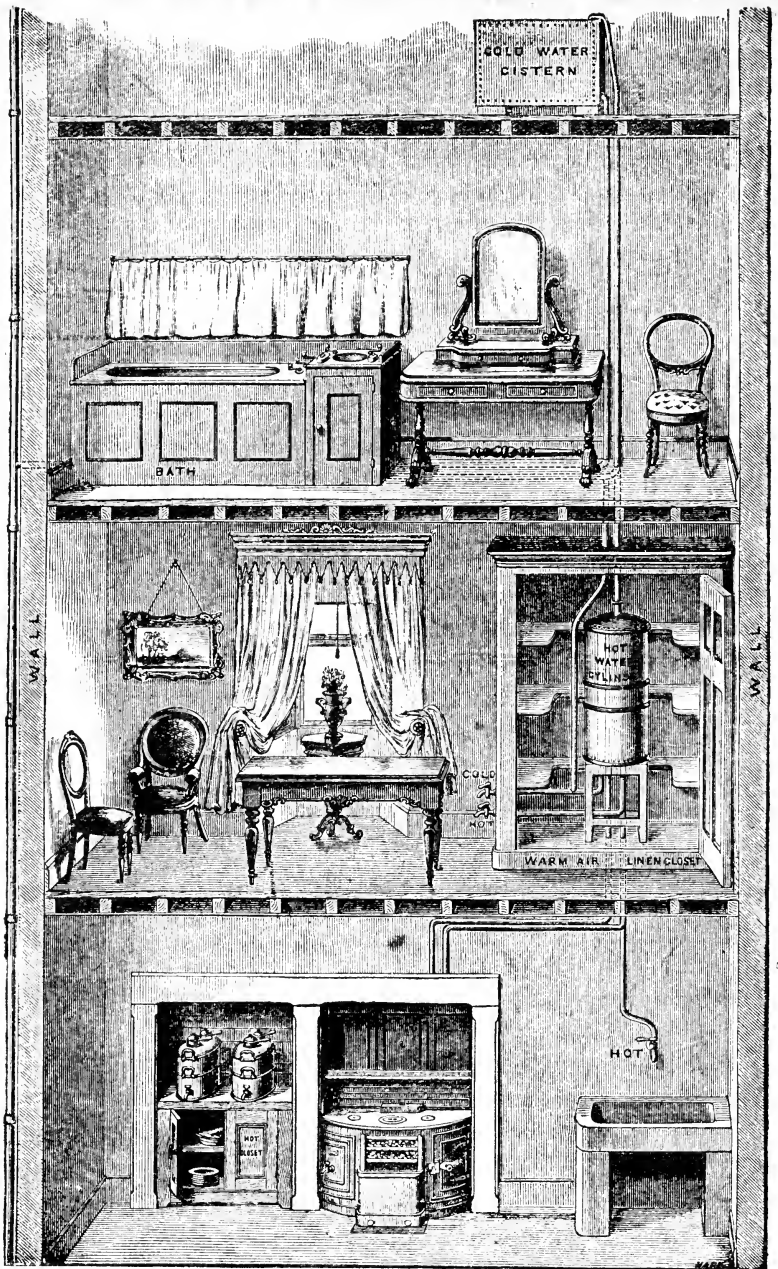

FIG. 361.—Hot-water circulation system defectively arranged.

1. The expansion pipe turned over the edge of cistern, as shown, would discharge hot water in constant flow into the cold cistern.
2. The cold supply to hot cylinder is improperly joined to a cold draw-off, whereby hot water would be drawn instead of cold, and the cylinder is in danger of being emptied.
3. Hot draw-off in kitchen is taken from the circulating pipes, instead of from top of cylinder.

heat causes the particles of water to expand in bulk, and therefore the bulk of water becomes lighter, when heated, than the same bulk in the tube which remains cool. Equilibrium being thus destroyed, the attraction of gravity, which is strongly drawing both columns towards the earth all the time, begins to draw one column with greater force, owing to its relatively greater density over the other, and as the heavy side of a balance, in being drawn downwards, pulls or pushes up the lighter side, so the heavier column of water presses up the lighter column, and will continue to do so, causing circulation so long as heat is communicated more to one column than to the other.

Hot water therefore does not rise because it is lighter than cold water, but because the cold water, being heavier, is pulled down by gravitation, and *forces* the hot water to rise. Comparing two columns of hot and cold air, or two columns of hot and cold water, they are each and all, both hot and cold, seeking to fall towards the earth. Remove their mechanical supports, and the hot air or hot water will fall by their gravity. They never rise of their own accord from the earth; they must first be pressed upwards by some corresponding column of greater weight and gravity displacing them.

Frost is too powerful an enemy to conquer, therefore a plumber's wisdom lies in evading it. All cold-water pipes and cisterns should be well covered and cased, and if pipes are underground outside they should be sunk two feet at least. When pipes are empty, frost has no power to burst them; therefore, when possible, all exposed cold-water pipes should be emptied in frost, and plumbers should devise the means of emptying them, leaving the responsibility on the householder to use the means at the proper time.

A stop-cock and draw-off cock at basement, and a simple

inlet suction-valve to admit air above at end of each branch, will, when actuated, empty the pipes.

A weighted lever to actuate these two taps has been devised, held up by a thin wire attached to a thin glass bottle or tube in a place exposed to frost. This lever will fall and empty the pipes automatically in frost by the action of the frost splitting the tube.

A new tube is required each time this occurs, but even that costs less than sending for a plumber.

Kidd's patent automatic apparatus, now little used, was found useful in Dublin when Vartry water supply was introduced. It is most ingenious.

A small cistern in scullery or basement, with a draw-off tap to empty it, held a double-action ball and cock, through which, when cistern was empty, the water flowed up the rising main to upper cistern. When this upper cistern filled, the overflow or warning pipe was led down to the small cistern, filling which, the ball rose and shut off the upward supply, at same time opening a tap on the rising main, which emptied it. Every can of water drawn from the small cistern by a servant set the apparatus in action again.

Frost is systematically guarded against in countries like Canada, where it is always long and severe. Considerable expense is incurred in securing pipes and tanks from its effects; but in this country, where real hard frost comes only once in a way, and then for only a day or two, householders will not sanction the cost entailed by precautions against frost, and when it comes hard it finds us unprepared and at its mercy. The plumber suddenly rises in the social scale, and becomes a man of mark to be conciliated and admired at last! We have more frost-bursts in a hard frosty week in London than during a whole winter in frost-bound Canada.



Hot-water pipes must be absolutely protected from frost or they become positively dangerous. It will be right to advise that circulating pipes be quite omitted from any house where they cannot be kept under cover and safe from frost; but where they can be safely laid, they may be made to serve as guards against the action of frost on the cold-water pipes, cisterns, and traps of the house.

Bear in mind that the house may be left empty during a week of hard frost, the fires being out, the water cold and frozen; on the reoccupation of the house, fires may be set going, and an explosion, resulting in loss of life and property, may occur, for which the plumber will be blamed.

Familiarity is said to breed contempt, and one must here consider that a long term of immunity from accident has a tendency to induce want of caution. The information acquired in some recent researches concerning this subject of domestic boiler explosions has startled the writer, and has impressed upon him, as he now desires to impress upon plumbers, the urgent need of extreme care and caution in designing and executing even the simplest installations.

That domestic boiler explosions are not such uncommon and rare occurrences as we have been led to suppose we shall soon learn.

In January, 1881, during a period of 9 days' frost, 32 domestic boiler explosions were recorded in the United Kingdom, and these 32 cases resulted in the deaths of 9 persons and in serious injury to 25 persons. In January, 1894, during a period of 5 days' frost, 22 domestic boiler explosions were recorded, resulting in the deaths of 10 persons and in serious injury to 29. In 1895, between the 3rd and 17th of February, 44 domestic boiler explosions were recorded, resulting in 9 deaths and 59 personal injuries in a period of one fortnight.

Numerous explosions of heating apparatus boilers in

churches, schools, and other buildings also occurred. How many more explosions of domestic boilers took place during these periods, and were for many reasons unrecorded, we shall never know.

Our business now is to inquire into the cause of these domestic disasters, and to suggest some methods for adoption for domestic security.

Domestic boiler explosions are chiefly caused by frost, and occasionally by incrustations, or by closed stop valves, obstructing the circulation of hot water and sealing up the boiler so that steam accumulates dangerously therein.

The usual custom in this country is to fix a boot-shaped or other form of boiler behind the kitchen fire, having a flue constructed underneath and behind, to expose as much as possible of the boiler surface to the full power of the flame; a strong forced draft is added in all close fire ranges. Independent boilers may be recommended in dwellings of importance, to relieve an overworked kitchen-range from the duty of supplying hot water to the household.

Flow and return pipes are usually laid down (on principles—good, bad, or indifferent, as the case may be) between the boiler and a closed tank or cylinder, placed preferably near the boiler in order to shorten the circulating pipes and to facilitate the taking of hot water for the basement from the upper part of cylinder. Sometimes the circulating pipes are led away to a hot-water tank on a high level; but in either case the cold water is drawn from a tank on a high level. The various methods of connecting boilers, pipes, and cisterns need not be discussed here; it is sufficient to state that the safety of the boiler, and of those persons having a life interest in its condition, depends on the provision of a constant supply of water, and upon the provision of means to keep the circulating, escape, and supply pipes always open and unobstructed. If a boiler, such as here described, be



hermetically sealed by any obstruction whatever, steam may form in fifteen minutes, and, rapidly accumulating, the pressure must quickly reach the point of resistance of the boiler plates, followed by an explosion, the force of which is observed and noted ruefully after the disaster has occurred. No man in his senses would thus hermetically seal up a boiler, yet every year hundreds of boilers are fitted and fixed in such an ignorant and slipshod fashion as to allow king frost to do the sealing more or less effectually. The frost may attack the system in the boiler itself if it is exposed, disused, in an empty house; the water in the boiler and in any pipes near it may be frozen solid. This probably occurs very rarely indeed, but the possibility of the occurrence renders caution necessary in lighting fires under boilers in cold, frosty weather in newly-inhabited houses. It may be that the only security available in such a case, where fires might be recklessly started, is in the provision of a dead-weight safety-valve of simple and sound construction, placed on the boiler itself in such a manner that if the valve was frozen solid along with the water in the boiler the heat of the fire would melt the ice and free the safety-valve before any damage from excessive steam pressure could arise. In this case it will be noted that a safety-valve on a pipe extended some distance from the boiler, or a safety-valve placed on the circulating pipes or on the cylinder, would be of no avail whatever, as the boiler would explode before the distant valve could be acted upon by the heat.

Frost does its work silently, unsuspected, and in a single night—all steam escapes are sealed, fires are lighted in the morning, and explosion follows. A very dangerous point in the hot-water arrangements, and one most frequently neglected, is that portion of the expansion pipe, where it passes through the roof, most exposed to frost.

The main cold tank is often placed on the ceiling level

under the roof, and the expansion pipe is sometimes carried along the roof rafters close to slates, or carried up through the roof slates at a point below the tank level, so that two or three feet of expansion pipe containing water exposed over the slates to frost action is here dangerously liable to become sealed by frost. In such a case, if the cold-supply pipe also becomes frozen, the whole system is hermetically sealed, and explosion follows: or, if the cold supply remains open, the water in the cylinder or pipes is forced back by the steam in the boiler up into the cold tank, thus deluging the house with a flood of overflowing water.

Incrustations, also, from hard lime or magnesian waters, or from the action of soft waters, such as the Vartry water, on iron pipes may seal up a boiler hermetically, but these deposits form slowly, and as they close up the bore of the pipes gradually the noise produced by the escaping cooped-up steam and water gives timely notice and creates alarm and inquiry. Serious explosions do not often take place from this cause.

It is commonly supposed that disastrous explosions are produced by boilers becoming empty and red hot, and while in this condition receiving a sudden supply of water. This has been proved to be a fallacy.

In fact, the cause of boiler explosions has been greatly misunderstood. In 1867 the Manchester Boilers Association made a series of useful experiments to elucidate the subject. Two copper boilers and one cast-iron boiler were heated to redness, when cold water was injected in one case through a  $\frac{1}{2}$ -inch pipe from the water company's main, and in two other cases through a 1-inch pipe from an overhead tank eight feet high. No explosion followed, and the boilers were unaffected, as the steam blew off through a  $\frac{7}{8}$ -inch escape pipe. In one experiment a safety-valve weighted to 35 lbs. was used, the boiler being of cast iron; when red hot, cold

water from a tank with 8-feet head was injected through a 1-inch pipe. The safety-valve did not blow, but the water in the injection or feed pipe heated back for 15 feet, indicating that a pressure sufficient to overcome the small head of water, but quite insufficient to blow off at the safety-valve or to cause an explosion, was generated. The test by pressure-gauge was made to show the actual pressure of steam in the boiler, but all the attempts to explode the boiler by injection of cold water failed, though everything that red-hot boilers and cold water together could do was done and every effort to succeed was made.

A very interesting experiment may be made with a copper flask, the neck closed by a cork having a small tube passed through it. Heating the flask to redness and removing it from the fire, a small quantity of water can be introduced through the tube; the water will assume the spheroidal condition noticed by Professor Tyndall, and will be repelled from contact with the red-hot copper, so that steam will not be generated until the temperature of the flask becomes low enough for the water to come in actual contact with the metal, when steam will be generated and the cork blown out. Possibly the pressure, if the flask had been hermetically sealed, would not have sufficed to burst the flask, as the quantity of water from which steam was generated would be so small. This point would be an interesting one to experiment upon further, so as to ascertain the pressure realised.

The numerous explanations of boiler explosions include the sudden "generation of an unknown and highly explosive gas," an explanation most mysterious and alarming, but unsatisfactory, as this gas has never yet been caught in the act, tried, or convicted. The "instantaneous evolution of steam under enormous pressure" following the sudden injection of water upon red-hot boiler surfaces affords a more

reasonable explanation of explosion, and is the theory most readily accepted.

Undoubtedly, cisterns and boilers are liable to become empty—whether from frost preventing the supply flowing; from lack of sufficient pressure in town mains; from negligence of those in charge of pumps; from cutting off of water supply owing to repairs of mains. This lack of water leaving the boilers liable to become empty, and, therefore, to become red hot, if fires be kept going, would occur, and does occur frequently, except as regards frost, at all seasons of the year; but we find all the records of burst boilers occur in frosty weather, unless in cases where dangerous stop-cocks on circulating pipes have inadvertently been shut off when fires are lighted, and the boiler thus hermetically sealed when full of water. We also find many cases coming to our notice where boilers give way within a short period owing to lime or other incrustations forming a shell or scale inside the boiler. In these cases the lime prevents contact of water with the surface of the metal plates of boiler. These plates, whenever a specially strong fire is applied, become red hot; the lime incrustation not expanding equally with the metal suddenly cracks, the water rushes in upon the red-hot plate, but no explosion ever follows. The plate cracks, water and a little steam escape, and the boiler sets up a permanent leakage, unless the incrustations re-form over the fracture.

It may be admitted that very few boilers burst in summertime. In one or two instances this was found to be due to the shutting off of stop-taps, hermetically sealing the boiler precisely as frost acts in winter.

An interesting series of experiments was made and recorded by Mr. R. D. Monro, chief engineer to the Scottish Boiler Insurance Company, to test effect of a sudden discharge of cold water into red-hot boilers.

Being a cautious Scotchman, Mr. Monro placed his boilers and furnace in retired safety within a wrought-iron shell, 20 feet high and 6 feet in diameter; the pipes were all brought outside, where the calm observation demanded by science might be secured, and there the pipes were fitted with steam-gauges, safety-valve, and an indicator tracing on paper the pressure curves. The indicator checked the pressure-gauges, and was found to accord closely with them in action. The water was turned on from a stand-pipe, 2 inches in diameter, 42 feet high, through a stop-valve, and, in some experiments, through a non-return valve, to prevent the return of any steam pressure to the stand-pipe on the admission of water to the red-hot boiler.

The boilers used were ordinary commercial kitchen boilers, of representative types.

A 14-gallon welded-iron boot boiler, fitted with a 1-inch stay in centre, screwed into front and back plates, and riveted over at the ends, tested to 60 lbs., and estimated to bear 120 lbs., was filled with water, and the stand-pipe was also filled, the pressure-gauge showing  $18\frac{1}{2}$  lbs., due to head; fire being started and maintained until water at top of 42-foot stand-pipe boiled at  $212^{\circ}$ , when temperature registered by thermometer at boiler under 42-foot pressure was  $254^{\circ}$ . The head of water was lowered to 10 lbs. pressure, when the temperature at boiler was noted at  $240^{\circ}$ ; and again at 5 lbs. pressure the boiler temperature registered  $225^{\circ}$ .

Of course we know that water boils at these different temperatures under different heads of pressure—from  $90^{\circ}$  in vacuum to  $212^{\circ}$  under our ordinary atmospheric pressure; and upwards to  $240^{\circ}$  at 10 lbs.;  $259^{\circ}$  at 20 lbs.;  $274^{\circ}$  at 30 lbs. pressure; representing 24, 46, and 70 feet head respectively—not uncommon heads of pressure for domestic boilers to be called upon to bear in working behind kitchen-ranges.

Now, a very serious point here deserves attention. Suppose that from any cause a boiler bursts under such high temperatures, the water boiling under the high pressure at  $30^{\circ}$  to  $100^{\circ}$  above the ordinary atmospheric pressure boiling-point of  $212^{\circ}$ , an immense volume of steam will be suddenly developed out of the large body of water liberated at one point.

But if the circulating pipes become blocked by frost, or incrustation, or stop-cocks, the pressure and the boiling-point may rise simultaneously to an enormous degree, until the point of rupture of the boiler is reached, when an explosion follows, with results that cannot be calculated beforehand.

The kitchen boiler, under a head of pressure, should, therefore, be treated as we treat a steam boiler; and, as far as practicable, the same precautions should be observed to avert danger of explosion.

The explosion of such a boiler not only means the emptying out of the boiler and pipes, such as would take place if the rupture occurred when water was below  $212^{\circ}$ , or under atmospheric pressure boiling-point; but it means that the latent energy of the stored-up heat, in proportion to the head of pressure and the volume of water, combined with the excessive temperature to which the water may rise above  $212^{\circ}$  under the known head of pressure, will cause an explosion and damage proportionate to the concentrated energy contained in the volume of water.

In all domestic circulating boilers the flow and return pipes, so long as they are unobstructed, act as safety-valves, but the amount of safety depends on the skill of the engineer or contractor, and on the arrangement he designs. The actual safety grows less in proportion to the length of pipes, the number of bends, the head of pressure, the risk of frost or incrustation, the existence of stop-taps, and the tendency

to deteriorate the strength of materials in boilers and fittings owing to the demand for cheap work. How often are such installations run up in houses built as speculations by jerry builders and jerry plumbers without supervision of any kind whatever! The marvel is that we do not hear of ten disasters of the kind for every one recorded.

But to return to the experimental tests. Taking a representative experiment:—The boiler being empty, was heated red hot by intense furnace fire inside the iron cylinder; the safety-valve—outside,  $\frac{1}{2}$ -inch diameter—loaded to 10 lbs., the column of water ready to discharge into boiler  $13\frac{1}{2}$  feet, indicating 6 lbs. on gauge. Water turned suddenly into red-hot boiler showed pressure of 12 lbs. on gauge within one second, the water in column was blown out with force, safety-valve blew off for nine seconds, gauge fell to 6 lbs., more water entered boiler, running the pressure-gauge up to 16 lbs., the maximum recorded; and these results would have continued, so long as conditions remained the same.

In another experiment  $\frac{1}{2}$ -inch diameter safety-valve loaded to 20 lbs., head of water 27 feet or 12 lbs. pressure, boiler heated to white heat, water turned in, instant pressure of 44 lbs. registered, but fell steadily to safety-valve load of 20 lbs. in 22 seconds; but as the pressure remained higher than that due to head no more water entered boiler and no increase of pressure occurred. Boiler was found distorted, the stay-bar was started and boiler rendered useless, but no explosion occurred. The  $\frac{1}{2}$ -inch safety-valve was not quite sufficient to relieve the boiler of the sudden volume of steam pressure in this exceptionally severe test, nor was the straight open stand-pipe, 2-inch diameter, able to afford such relief as to prevent the pressure rising above that due to the head. In other points the tests were much more severe and searching than in ordinary practice domestic boilers would ever be subject to.

In another experiment the stop-valve was fitted with back-pressure valve; the head of water was 40 feet. The safety-valve was increased to 1-inch diameter, loaded to 40 lbs., boiler heated red hot, water on first entering created a vacuum for a few seconds and then steam generated, pressure rose steadily, and safety-valve blew off freely. This test would resemble the result likely to occur in ordinary circulating boilers if the flow and return became frozen, and boiler from any cause became empty under the frozen pipes—a condition not at all likely to occur.

From these experiments we may assume that in all ordinary boilers a  $\frac{1}{2}$ -inch safety-valve will suffice, and a  $\frac{3}{4}$ -inch safety-valve will be more than sufficient to carry off all steam likely to be generated.

Experiments up to bursting pressure were also made. The safety-valve was locked down, and boiler sealed hermetically. Boiler heated red hot, water turned in, pressure rose to 60 lbs. when a leakage occurred at one of the joints; this checked rise of pressure a few seconds when it rose to 118 lbs., and a portion of the welding of boiler gave way with a leakage of steam at heads of the stay between front and back; the boiler was bulged, the openings at weld 8 inches long by  $\frac{1}{16}$  to  $\frac{1}{8}$  inch wide, not exceeding 1 square inch area, and sufficient to liberate the contents in 3 seconds. The noise which was produced at rupture was rather the noise of a safety-valve suddenly coming into action than the noise of an explosion.

The boiler, it will be observed, had no volume of water in it at high temperature, but was full of expansive steam, which was quickly disposed of without explosion.

Several other similar experiments all tended to establish sufficient proof that a disastrous explosion cannot be caused by cold water rushing into red-hot boilers in the ordinary condition. Of course the rupture of a boiler might take



place under such circumstances, but it could not be attended by the awful consequences which ensue if boilers burst when filled with water under enormous concentrated pressure and high temperature, the outlets hermetically sealed by frost or other cause.

Having thus learned by the careful experiments of others that the instantaneous generation of steam in boilers is not the cause of the frequent disasters recorded, let us proceed. Domestic boiler explosions are caused simply by a gradual accumulation of pressure within, by reason of the outlets becoming sealed at the time that strong fires are at work and the boilers full of water. The use of safety-valves is advocated by the engineers of the various boiler insurance associations in England and Scotland, notably by Mr. Fletcher and by Mr. Monro; and when we remember the long and extensive experiences of such men, and consider their position of grave responsibility when tendering professional advice, and pressing it upon the public with unswerving persistence for so many years, we will do well to take heed to the warnings they reiterate again and again.

The writer has fixed hundreds of domestic hot-water installations, following the accepted practice in this country and not employing safety-valves, and has never had to record a disaster; care and caution in protecting pipes, along with the usually mild character of our climate, has secured such results; but the practice adopted here in the best class of work would not serve in a colder country, and in view of the startling number of serious accidents recorded, one is inclined to modify one's views and practice so as to avoid possible risks. Some precautionary suggestions are offered towards securing the desired result of a still greater margin of safety for the public.

The objections to safety-valves on domestic water boilers should be considered. Domestic boilers with safety-valves

differ from steam boilers with safety-valves to this extent, that the former are kept full of water to the top, in actual contact with, and filling the safety-valve up to its under side, pressing constantly against it without any elastic steam cushion between, with the same force per square inch exerted against the upper boiler plates. That force is in ordinary houses from 10 to 30 lbs. per square inch, due to the head of water in the cold supply tank.

Ordinary plug-cocks are frequently found on the hot-water pipes, which when shut off suddenly, produce a ramming action, increasing pressure so greatly that even when the valve is loaded for double the normal pressure it is forced open by the shock, and some water escapes over the boiler and range; if this occurs frequently, corrosion will be set up outside and deteriorate boiler and kitchen-range. The obvious method for preventing this ramming action is to substitute screw-down valves, preferably those of the type patented by Lord Kelvin, removing all plug-valves from the system.

Another objection raised is that the valves themselves have been found unreliable in action. They are not under the observation and care of skilled persons, as they would be in the case of steam boilers, and the proper position for the valve, directly over and close to the range boiler, is surrounded by brickwork, and not always under observation, consequently the valves may in time be neglected and stick fast on their seating, and fail to act in the hour of danger.

A tolerably fair answer to this objection is, that although there are many unreliable safety-valves, there is one type which may be considered reliable when carefully made and properly fixed and protected; that this type of valve has been proved for many years, and that it is recommended for adoption by the highest authorities; and

further, that, so far as the writer knows, no explosion has ever occurred where a valve of this type has been properly fixed.

Possibly with the universal adoption of safety-valves there will grow up also an undesirable laxity in the design and quality of boilers and fittings, and a false feeling of security may be created; that objection, however, should be taken as a caution against such carelessness and laxity, rather than against such security as a good and reliable safety-valve may afford.

The objection to valves on the ground that they cannot relieve the boiler sufficiently in event of sudden generation of steam in a red-hot boiler has been disproved effectually by experiments, and as it would not seem wise to omit safety-valves from steam boilers because that, in some instances, they failed to avert explosion, neither does it seem altogether prudent to exclude them from the repertoire of necessary domestic securities in this age of domestic advancement and domestic complications, for the same reasons.

The safety-valve best suited for domestic boilers is of well-made external, pendulous, deadweight construction, without lever, spindle, hinged joint, or wings. Hundreds of these are now in use.

The disastrous explosions recorded have called forth many types of safety-valves, of which some may be here noticed, and efforts have been made to revolutionise the domestic system of heating water also, with more or less effect.

The spiral brass spring safety-valve is capable of being regulated by turning a screw to suit various pressures, but this action must depend on the judgment of the workman who regulates the valve. The principle is cleverly adapted also to the nearest draw-off tap of the boiler, so that, in

drawing water for domestic purposes, the valve is opened many times daily, and is thus prevented from sticking fast, as other valves may do, through want of usage. Therefore, one of these might be used on the scullery draw-off tap, in addition to the deadweight safety-valve on boiler, when the pressure due to head is small enough to preclude the effects of ramming.

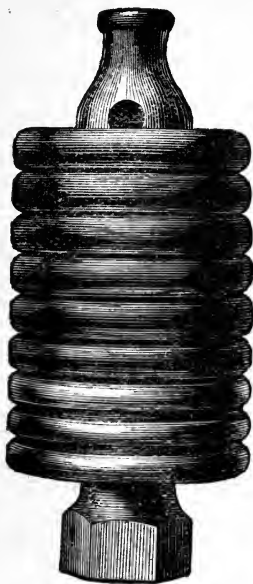

FIG. 362.—Domestic boiler safety-valve.

The ground-in common safety-valve is, undoubtedly, liable to stick fast on a water boiler, and is only suited to steam boilers.

We have another safety appliance for domestic boilers which, though not properly a valve, is named the "Relief Valve."

A short pipe, 18 inches long, is fitted to the boiler, at the end of which the valve is screwed on. It is formed of brass, enclosing a plate of mica tested to 60 lbs. per square inch, and at that pressure the mica is expected to crack and relieve the boiler instantly, discharging into the chimney, or wherever the relief-pipe may be led to deliver.

The objection of this plan appears to be that after each occasion, when the valve acts, it must be taken asunder and a new mica plate be inserted; and it seems clear that the point of resistance of the mica must always remain an element of uncertainty until the moment of fracture occurs. The safety-pipe leading to the valve would be liable to closure from incrustation, and the valve being difficult of access and inspection at all times, the security offered is an unknown quantity.

Fusible plugs, on kitchen boilers, are also unreliable. No one can guarantee or foresee the condition of fusible plugs, or be certain that they will fuse at the critical moment. There are always—nervously—grand possibilities of fusion taking place too soon, extinguishing the fires and deluging the kitchen on the eve of a dinner-party, or other solemn function, when the host and hostess require all their wits to induce their guests to suppose that they are being pleasantly entertained, without danger from either explosion or deluge.

We may now turn for a moment to consider a principle of heating water for domestic use which is being pressed on the public as a sovereign preventive of all explosion under all circumstances.

The hot water from the kitchen boiler is conveyed through flow and return pipes, not into the cylinder, but into a chamber, formed in the bottom of the hot-water cylinder, which is fixed in a position near to the boiler. The kitchen boiler, circulating pipes and cylinder under chamber are supplied through an open cistern placed on a level with the bottom of cylinder. Two or more open pipes are led from the chamber bottom up through the cylinder, and these are open to air at top of cylinder.

An open pipe is also led from the boiler up to the level of the other open pipes.

The hot cylinder is supplied with water from a store cistern at any level above that at which hot water is drawn, and the cold water is warmed only by contact with the top surface of the hot-water chamber under same, and is not otherwise connected with the boiler. The cylinder has the usual expansion-pipe, carried from its highest point up above the level of store cistern, and the supplies of hot water are taken from this expansion-pipe as well as the supply to feed the cistern of the boiler.

There can be no doubt that this system is free from danger of explosion; unless the circulating pipes become frozen solid no steam pressure can arise, but also the heating

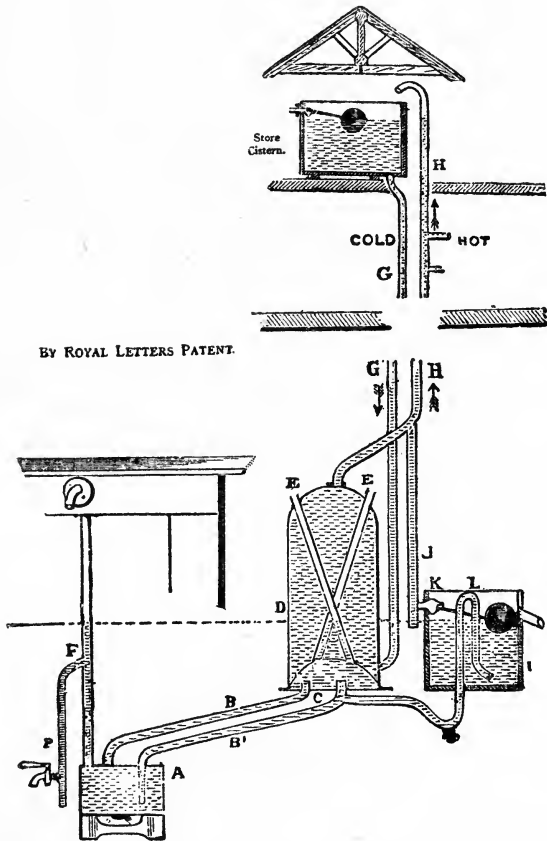

BY ROYAL LETTERS PATENT.

FIG. 363.—One of the many forms of application of Walker's steamless and non-explosive principle.

power must be necessarily small as compared with the ordinary system of circulation, and more time must elapse before a large body of water could be heated by this indirect method.

The hot water from the kitchen boiler A circulates through the closed chamber C of the cylinder D, by means of the flow and return pipes B, B<sup>1</sup>, thereby heating the water contained in D. The cylinder D has water supplied to it by pipe G from the store cistern above, while the boiler A receives water from the cistern I, which is itself supplied from the cylinder D by the pipe J and ball-float valve K. A stand-pipe F is fitted to the boiler A for withdrawing hot water by means of the pipe P; a syphon L is fitted to the supply-pipe M of the boiler A to prevent water entering the boiler when the latter is empty. Vent-pipes E prevent the pressure in the chamber C from rising above that of the atmosphere. With these arrangements the pressure in any part cannot rise much above that of the atmosphere; or if the boiler A becomes empty and is heated to redness, no water can pass into it because of the syphon tube L on its supply-pipe.

The three short pipes which ventilate boiler and cylinder are open in kitchens, and no inconvenience arises through same, as they simply admit air without emitting steam, the latter being all condensed by cylinder.

A scientific friend of the writer has just patented another safety system, which consists of a coil of pipes (preferably copper, owing to its power of rapid conduction of heat) placed in an open boiler, the ends of the coils being extended to any tank or cylinder as ordinary flow and return; the boiler is kept full, notwithstanding evaporation, by an ordinary feed cistern with ball and cock self-filling.

The hot cylinder or tank is supplied in the ordinary way from a store tank above the level where hot water is to be drawn, and the cylinder is fitted in the usual way with expansion-pipe and draw-off pipes.

It is now evident that the water in the open boiler, being under no more than atmospheric pressure, cannot rise above

212°, and that no pressure of steam can accumulate in boiler or in pipes. It is also evident that as fast as the water in the coil absorbs heat from the boiling water and expands, it will circulate away to the cylinder or tank overhead by the pressure of the colder water falling from the cylinder or tank, and that eventually the whole body of water in the cylinder would rise to 212° if no heat was wasted by radiation or otherwise.

The writer carried out several experiments to ascertain the amount of heat that would likely be wasted in this process.

With an open boiler kept to boiling-point, and with the various coils circulating water through a 30-gallon open tank 3 feet above the open boiler described, the following results were obtained in successive periods of half an hour each in the tank:—

A 12-feet coil of $\frac{3}{8}$ -inch copper	72°	98°	120°	130°	132°	135°
„ 6 „ $\frac{3}{8}$ „	72°	80°	85°	90°	110°	120°
„ 6 „ 1 „	72°	86°	120°	138°	144°	160°
„ 12 „ $\frac{3}{4}$ „	72°	100°	130°	150°	170°	175°
„ 6 „ $\frac{3}{4}$ „	72°	90°	110°	140°	155°	160°
„ 12 „ $\frac{3}{4}$ -inch lead pipe	72°	95°	120°	130°	130°	

A 12-feet coil of  $\frac{7}{8}$ -inch iron pipe, resting in boiler in contact, 72°, 145°, 162°, 170°, 175°.

A 12-feet coil of  $\frac{7}{8}$ -inch iron pipe, not touching boiler, 72°, 90°, 110°, 130°, 140°, 160°, 170°.

Closed boiler circulating direct, 72°, 160°, 180°, 200°, 212°.

These results clearly show that a large amount of heat was wasted during the process.

If we had used, instead of an open boiler, one of the ordinary closed circulating boilers, we would have found the results much better; in fact, we could have boiled the 30 gallons in less than 2 hours.

It is manifest that great loss of heat must take place by any indirect system of heating. This loss of heat may, perhaps, be compensated by the greater security obtained



by the prevention of dangerous accumulations of steam, rendering explosions impossible.

There is also to be mentioned the double boiler, or gluepot boiler system, which consists of a circulating boiler immersed wholly or partially in an open boiler, gluepotwise, with circulating pipes from the inner boiler to and from a hot cylinder or tank at a higher level. The safety here is undoubtedly secured, provided that the outer boiler is always full; temperature in inner boiler cannot reach  $212^{\circ}$ , no steam can be formed, and therefore no explosion can occur.

The explosive energy in a kitchen boiler heated red hot, and filled with steam from water suddenly injected, as in the experiments quoted, is small when compared with the enormous accumulation of force confined in even a 12-gallon domestic, high-pressure boiler full of water, and hermetically sealed by frost, or by stop-cocks, and with a fierce fire playing upon it for some time.

We may conclude that many disastrous explosions have occurred with domestic boilers when hermetically sealed, chiefly during severe frost, and when full of superheated water under pressure. That the force of these explosions is always proportionate to the temperature and quantity of water in the boiler, and to the resistance of the boiler overcome. That steam at very high pressure may be produced in a red-hot boiler by the sudden entrance of water, but that the volume of steam in these circumstances being small a very slight crack or rupture relieves the internal pressure, so as to prevent any disastrous explosion, and that a proper safety-valve would relieve this pressure without any rupture. That domestic boilers, working under a pressure due to the head of water produced by cisterns at a high level, should be constructed with the same care and caution as if they were steam boilers, and be capable

of sustaining safely at least four times the normal pressure. That installations may be arranged and carried out by experienced engineers, so as to be perfectly safe in all circumstances without the use of safety-valves, but that it is desirable that the adoption of deadweight safety-valves should become general, as experience shows that numbers of domestic installations are constructed in such a negligent fashion as to be liable to explosion when severely tested in time of exceptionally severe frost. That some method of authoritative inspection and control of domestic boilers would prove beneficial as a preventive of accidents.

All water-pipes should, where possible, be laid along inner walls and in warm parts of the house.

All the lead circulating and other water-pipes should rest on thorough timber supports, well secured to walls, having a marked rise in gradient from the boiler upwards, in order to secure the free upward escape of air-bubbles and steam. No dip or trap in the pipes should occur at any point. Even if you come to some spot where you see no way to avoid a dip, do not give it up, but plan *some* way rather than spoil your system. Assuredly that dip will cause trouble.

One often sees pipes hung along the walls on hooks, sometimes even without a piece of lead between the pipe and hook to prevent cutting, and the pipes all dragging down and hanging in festoons from hook to hook.

When fixing pipes vertically on the face of a wall or in a chase, timber should be first fixed to secure them to, and the pipes should be screwed to the timber by lead tacks, or flaps soldered on about four feet apart. Iron hooks, even with lead clips, should never be used, as in time the weight of the lead drags it through. Besides, the pipe is liable to receive damage from the plumber's hammer, for he does not always strike as straight as a blacksmith.

Flanged supports on hot pipes are apt to bind the pipes and to cause transverse fracture, owing to want of freedom for contraction in cooling. On no account whatever should stop-valves be allowed on circulating pipes. And, lastly, pipes of every kind should be freely exposed to view, or arranged so as to be easily got to and handled. Let good plumbing work come to the front and flourish.

## CHAPTER X.

### PLUMBERS' MATERIALS.

THE materials with which plumbers work require some consideration and study.

*Plumbum*, or lead, is the godfather and godmother of plumbers, for it gives them their name, and must be included in their catechism.

Technical schools should possess specimens of lead in the various stages of its manufacture. Many plumbers working in lead every day know little of its origin, manufacture, and qualities. It is, therefore, the duty of technical teachers of plumbing to impart this information.

Lead is seldom found in the native state as a complete pure metal, in plates or veins, crystals or nuggets, as gold is found. It is reduced chiefly from an ore called galena, or sulphuret of lead, or plumbic sulphide,  $PbS$ . Occasionally pure lead is extracted from carbonate of lead or cerrusite—1st, by the mechanical processes of crushing, sifting, and washing; 2nd, by the chemical processes of smelting, softening, and refining.

Galena is found in Spain, England, and indeed in nearly all parts of the world. It is in veins, both in the clay-slate of Cumberland and in the limestone of Cornwall, mixed with quartz, blende, baric sulphate, and fluor spar.

Pure galena is composed of 86.55 parts of lead and 13.45 parts of sulphur. It has a deep leaden colour, and when found in cubes resembles lead; but it is a distinct mineral,

and may be artificially formed by melting lead and sulphur in the proportions given.

Silver is generally found in galena, in variable proportions, ranging from two ounces per ton up to eight hundred ounces per ton in the mines of Colorado.

Antimony, iron, and copper also occur in galena frequently; they are objectionable impurities in lead, rendering it hard and unworkable.

When the galena has been obtained it is first gone over by hand and the purer parts selected as ready for smelting at once; but it is necessary to break up the greatest portion of ore into pieces about one inch cube, or the size of a walnut. The rougher parts are then passed through revolving cylinders and crushed, and further separated through sieves. The finer portions of the galena are subjected to the further operation of jigging in a sieve over a pit through which water flows. The sieve is plunged and agitated, and the finer galena falls to the bottom, while quartz and fluor spar remain in the sieve. The jigging system is extended elaborately in some works, for further separating the ore, by employing sets of tubs with four compartments in each, over which the ores are passed in suspension, and allowed to subside and separate according to their specific gravity, the heavier portion collecting in the first compartment, and every available atom of ore being extracted before the water is allowed to escape.

The galena is now selected for roasting and smelting. About one ton is placed on the bed of a reverberatory furnace; that is, a furnace where the coal used does not come in contact with the ore, as it does in the Scotch furnace, but so constructed that the inflamed gases from the fuel strike the brick arch, reverberating and rolling along it in flame directly over, and radiating the most intense heat upon

the ore. The galena is raised in a short time to a cherry-red heat, care being taken to prevent overheating or fusing. If the galena was allowed to reach a white heat, scales of sulphate of lead would form round the ore and prevent its reduction. When the proper degree of heat is attained the doors are opened, and the ore is stirred and turned over and over with iron flat-pointed rakers or paddles, and cooled down by admission of air, thus gradually desulphurizing the ore. The sulphur in the galena burns off, some plumbic oxide is formed, and a portion of the galena is converted into sulphate, but yet much of the ore remains undecomposed. Care is still observed to prevent the heat rising so as to fuse the galena, and the mass is kept well stirred from both sides of the furnace with long iron rods having paddle-shaped ends.

When this process has been carried to a certain point, and the materials are thoroughly mixed, so as to be in a pasty condition, the furnace doors are closed, and the heat is suddenly raised. The plumbic oxide and sulphate then react on the undecomposed sulphide of the galena, a large quantity of sulphurous anhydride is evolved, and the metallic lead is set free and flows from the furnace into iron basins.

Quicklime is used at certain intervals to make the slag less liquid and easier of removal.

If the lead is found to contain antimony or tin, it is improved or refined by being melted and exposed in shallow cast-iron trays in the bed of a reverberating furnace. An oxide forms on the surface, in which the antimony and tin is removed.

The workman examines samples of the metal taken out from time to time, and when it shows a peculiar flaky, crystalline appearance the lead is run off and cast into moulds or pigs.

The silver in lead is extracted by various processes. When

lead contains only two or three ounces of silver to the ton the extraction of it is profitable, not only on account of the intrinsic value of the silver, but also because the process improves the quality of the lead, which is the point of interest to plumbers.

Pattinson's process of desilverization is still employed, though it is being superseded. The fusing-point of an alloy of lead and silver is under that of lead, so that when lead containing silver is melted and stirred quickly, while cooling slowly, a portion of the lead, nearly free from alloy, solidifies and falls to the bottom of the still molten mass of alloy. A series of metal pots are set in brickwork, with an independent furnace under each; a ton or more of lead is melted in the central pot, and then slowly cooled and stirred; a perforated ladle is used to lift out the solidified and partially desilverized lead into the neighbouring pot, until about three-fourths or even more of the lead has been transferred; then the remaining portion, rich in silver, is poured into the neighbouring pot on the opposite side. When a sufficient quantity of metal is collected in the right and left hand pots the process is repeated in them; the lead and silver becoming, during each melting and cooling, more thoroughly separated, till the last pot at each end of the row is reached, where at one end the lead is found, greatly improved in all the desirable qualities of lead, while at the other end the argentiferous lead contains perhaps three hundred ounces of silver to the ton, and is ready for cupellation or any other process of refining.

By an improvement on Pattinson's process machinery is employed to do much of the work. Two pots are used, the level of one commanding that of the other—the upper pot containing about twenty tons, and the lower pot about thirty-eight tons. The large pot is covered in and connected

with condensers, and a lifting crane is used for transferring the purified metal to the moulds. When the lead is fused in the upper pot it is run off into the lower pot, where the crystals of lead have been left from the previous operation. These crystals melt; the scum is removed, and steam, uniformly distributed under pressure, is forced through the lead for the purpose of agitating it, to induce the crystallization, which is also hastened by small jets of water playing on the molten surface. The cooled portion sinks; the temperature uniformly and gradually falls to crystallizing-point, the steam jets ensuring the full effect throughout the mass. When an hour has elapsed, about two-thirds of the metal is crystallized, and the liquid one-third remaining is then drained off. A fresh charge of lead is now run in, and the process is repeated. The quality of the lead resulting from this process is so good—all antimony, arsenic, zinc, copper, and iron having been removed in the steam—that no subsequent softening process is necessary, and the saving of fuel and labour is very considerable.

Lead is also desilverized with the assistance of zinc. Lead and zinc do not alloy, but, on being slowly cooled, separate into two distinct layers. Silver has a greater affinity for zinc, and rises with it to the surface when the mixture is slowly cooled, and it leaves the purer lead behind. Zinc is mixed with the molten metal, and after being slowly cooled, a crust of argentiferous zinc forms on the surface, which is lifted out and placed in a pot for further refining. The lead remaining is heated to redness, and the zinc still in it is removed as oxide by the action of superheated steam.

The argentiferous zinc scum is separately treated, and a zinc oxide is disengaged, containing a mixture of lead and silver. Hydrochloric acid is sometimes used to remove the zinc from the silver, or the scum may be treated by cupellation under high temperature, and the zinc is removed in the slag.



The process of cupellation, now used only for extracting silver from rich concentrated argentiferous lead, was formerly the only method practised for desilvering lead. The principle of the process is simple. When gold, silver, or platinum is exposed in fusion to the action of air they retain their brightness, and do not oxidize like lead and the baser metals, and hence these are called noble metals. So, when silver is alloyed with lead, and the alloy is melted in a furnace in contact with air, the lead gradually becomes oxidized. The scales of the oxide of lead, or litharge, rising to the surface, can be removed to undergo the process of conversion into red lead, etc., leaving the pure silver behind. When the last traces of the litharge are being volatilized, a very beautiful phenomenon, known as brightening, is observed. At this moment the small remaining pellicle of fused litharge spread on the surface of the molten pure silver quickly becomes thinner and thinner, presents in rapid succession all the iridescent tints of the rainbow, and then is suddenly torn up like a veil and vanishes, leaving the bright glowing surface of the pure silver exposed.

One of the principal questions in plumbing examinations is this: What are the peculiar physical properties of lead?

The answer will be given, perhaps, thus: Lead is in colour a bluish-white, or grey, with metallic lustre; it is so soft that it can be marked or impressed with the edge of a thin horn; it communicates a dark mark if drawn across white paper, minute particles of lead being transferred; it is plastic, malleable, flexible, fusible, durable, heavy, and therefore serviceable for many useful purposes; it is not ductile or easily drawn into wires; it is wanting both in tenacity and elasticity; it is a bad conductor of heat and electricity.

The fusing-point of lead, as given by various authorities, ranges from 612° to 630° F., but is now generally stated at

617°; a slight variation of quality or purity would fully explain these differences.

It is also important to remember that the density or specific gravity of lead is fixed at 11.38, because, in dealing with it in alloys, such as solder, the plumber has to use certain practical precautions on account of this fact.

When lead is repeatedly heated and cooled it becomes permanently enlarged; but as it contracts at the moment of solidification when cooling, it is an unsuitable metal to use for castings.

Repeated melting, when exposed to air, hardens lead, but its softness can be recovered by again melting and stirring it under a layer of charcoal for some time.

One of the principal questions for honours in plumbing is generally this: What are the peculiar chemical properties of lead?

It is volatile at a red heat, yet not enough so to be distilled.

It absorbs oxygen from the air freely at high temperatures, then throwing off white fumes of oxide. Acetic acid vapours attack and corrode it, changing it into white lead, or carbonate of lead when carbonic acid is also present.

Lead is nearly free from the influence of alkalies. Chlorine forms a film of chloride on the surface of lead, which protects the metal from further action; but chlorine will slowly convert lead into chloride, if it be kept in contact.

Calcic sulphate corrodes lead when moisture is present, so that lead pipes should never be covered in stucco or plaster. Pieces of plaster or mortar falling into a lead cistern are found to corrode the bottom into holes where in contact with the lead under water.

Lead, when scraped or cut bright, on exposure to the

air becomes tarnished by the formation of a thin film of oxide, which, however, serves to protect the metal from further change; therefore plumbers find the need of coating shaved lead with touch to preserve it bright for solder jointing.

If bright shaved lead be placed in pure water, from which all air has been expelled by long boiling, it will retain its brightness, but when exposed to the united action of air and *pure* water, or of pure water containing air, it is attacked and corroded. The air oxidizes the lead, and the water dissolves the oxide. This solution absorbs carbonic anhydride, a film of hydrated basic carbonate of lead is deposited in silky scales, then a fresh portion of oxide is formed by the air and dissolved by the water, and a rapid corrosion results, which in water cisterns, under these conditions, is frequently recognised by plumbers.

The presence of chlorides and nitrates increases this corrosion, and very minute quantities of nitrites confer the corrosive action on lead also.

Nitrites and nitrates, due to the decomposition of nitrogenous organic matter, are often present in river waters, which act on lead injuriously.

Phosphates and carbonates do not favour corrosion of lead. Plumbic oxide is scarcely soluble in water containing these salts in solution.

A solution of carbonate of lime in carbonic acid and water has a remarkably preservative influence.

The red oxide of lead (=red lead, or minium,  $Pb_3O_4$ ) is used in the manufacture of flint glass, and is mixed with carbonate of lead, or white lead, to form a kind of putty for staunching screwed joints and manhole plates.

Various chemical products of lead are used as pigments—the white carbonate of lead = white lead, or ceruse,  $PbCO_3$ . Litharge and massicot are also red oxides of lead.

Lead has many uses in peace and in war. It serves to cover flat roofs, to form the gutters and down pipes of sloping roofs. It is the ordinary metal used in lining water cisterns, and in forming pipes to convey water to and from them. Lead is employed in the lining and construction of chambers and vessels in which sulphuric and other acids are manufactured in chemical works.

Lead is used largely in alloys, as solder, pewter, Britannia metal.

Lead is used for sash weights, for ballast in racing yachts, and for many other purposes where its great density gives the greatest weight in the smallest space.

Types for printing are formed from an alloy of two parts of lead, one of tin, and one of antimony, or fifteen parts of lead, one of tin, and four of antimony.

Rifle bullets are made with pure soft lead. Bullets for smooth-bores are made with an alloy of five parts of lead and one of antimony, to give penetrating hardness. Small shot contains three to eight parts of arsenic per thousand, which alloy is hard, and assumes a globular form when dropped into water.

The object of the tall shot-towers we see in lead works is to allow the shot to cool gradually by falling a long distance before entering the water. If too rapidly cooled the outer shell of the shot would harden first, and as the interior would continue cooling and shrinking, it would collapse the outer skin and spoil the symmetry of the shot.

The tensile strength of lead is 1,800 lbs. per square inch, which is very little compared with 29,120 lbs. per square inch in cast iron.

The compressive strength of lead is 7,600 lbs. per square inch, which is a still smaller proportion to 143,360 lbs. in cast iron.

The specific gravity and fusing-points of certain metals concern plumbers practically.

Tin	fuses at	442°	to	455°
Bismuth	„	507°	„	518°
Lead	„	612°	„	630°
Zinc	„	773°	„	793°
Antimony	„	800°	„	810°
Silver	„	1,830°	„	1,870°
Copper	„	1,996°	„	2,050°
Gold	„	2,016°	„	2,280°
Cast iron	„	1,920°	„	2,190°

If water be taken at unity as the standard, we have the specific gravity of metals as compared with it. Water being 1, then, as compared with water, quartz is 2.65; fluor spar, 3.1; basic sulphate, 4.6; antimony, 6.71; zinc, 6.86; cast iron, 7.25; tin, 7.29; galena, 7.6; silver, 10.53; mercury, 13.6; gold, 19.36.

Manufactured lead is obtained by plumbers in four forms—pig lead; cast sheet lead; milled sheet lead; pipe lead.

The old method of casting sheets of lead is nearly superseded by rolling and milling.

Cast lead is still considered by some persons as free from some of the faults of rolled lead, but practical plumbers would prefer rolled sheet for any purpose. Cast lead is specified occasionally, and then the plumber may make it himself from the waste lead and clippings of his workshop.

A strong table with a smooth top, having raised edges, is required. This is covered with a layer of fine dry river sand, perfectly level and smooth. The molten lead is poured into a heated oblong trough, fixed across the table; the metal is poured thence in a wide stream upon the sand as evenly as possible; a wooden roller is rested on the raised edges and pushed quickly along, spreading and driving forward the lead, and leaving an even uniform thickness behind on the table to cool.

Cast sheet lead should never be made of less thickness than eight pounds to the foot, as it is liable to be irregular and to contain minute sand or air holes or flaws.

Milled lead is first cast in an iron mould into plates about six feet square and six inches thick. It is lifted by a crane upon the rolling mill, where it is drawn in by small reversible rollers under heavy metal cylinders, the upper cylinder being supported on regulating screws to relieve the lead at first from too great a pressure, and to enable the workman to lower the cylinder gradually as the sheet becomes thinner. As the lead passes through, under pressure between the metal cylinders, it is compressed and elongated. A long bench of rollers receives and carries along the sheet over a bench as it passes back and forward, the top cylinder being allowed to descend more and more each time by a turn or two of the regulating screws. The workman is able to judge when the requisite thickness of sheet has been attained by merely measuring the length of the sheet.

The 6-foot square piece of lead may be lengthened by this process into a sheet of lead from two hundred to four hundred feet long, according to the thickness.

The usual market thicknesses of rolled sheet lead are 3, 4, 5, 6, 7, 8, 9, 10, 11, and 12 lbs. per superficial square foot; but lead can be rolled much thicker. The sheets usually measure 25 feet to 35 feet long, by 6 feet to  $7\frac{1}{2}$  feet wide. The lead manufacturers prefer to sell their sheets the full width as it comes from the mill.

For aprons or flashings 3-lb. lead is always too light; in any exposed position 5-lb. or 6-lb. lead should be used.

Roof-flats and gutters require at least 7-lb. and 8-lb. lead; hips and ridges, at least 6-lb. and 7-lb. lead. Much heavier lead may be used with ultimate advantage in exposed positions and in all high-class work.

The weights of sheet lead may be known by the thickness:

$\frac{1}{20}$  of an inch = 3 lbs.;  $\frac{1}{15}$ , 4 lbs.;  $\frac{1}{12}$ , 5 lbs.;  $\frac{1}{10}$ , 6 lbs.;  $\frac{1}{8}$ , 7 lbs.;  $\frac{1}{5}$ , 8 lbs.;  $\frac{1}{4}$ , 9 lbs.;  $\frac{2}{13}$ , 10 lbs.;  $\frac{2}{11}$ , 11 lbs.;  $\frac{1}{5}$ , 12 lbs.;  $\frac{1}{4}$ , 15 lbs.

On the Birmingham wire-gauge the various thicknesses of lead should barely enter the gauge very tight at the following numbers: 3 lbs., 18; 4 lbs., 16; 5 lbs., 14; 6 lbs., 12; 7 lbs., 11; 8 lbs., 10; 9 lbs., 9; 10 lbs., 8; 11 lbs., 7; 12 lbs., 6.

Architects, surveyors, and master plumbers, by carrying with them a pocket gauge, can thus easily and effectually check the weights of lead laid down on a building.

Lead pipes were formerly cast in short lengths of considerable thickness, the bore being made the size required, and the pipes being afterwards drawn out and reduced to any desired weight and strength.

The hydrostatic press now produces lead pipes perfectly finished in long lengths; they are pressed out from a cylinder of molten lead through a die or mould of any diameter, and are coiled round revolving drums.

The sheet and pipe lead used in Dublin contains an admixture of three parts tin, which effectually checks the chemical action on the pure Vartry water with which Dublin is supplied. For use with all pure soft waters this alloy should be used.

With reference to tin-lined lead pipe the writer has not much experience, but the making of wiped joints, owing to the fusible nature of tin as compared with lead, must be a very great difficulty, lead not melting till  $617^{\circ}$ , while tin melts at  $442^{\circ}$ . Professor Frankland said the public should be warned against the use of tin-lined lead pipe. In some cases, he states, the two metals produced an alloy which acted more on the water than lead pipes alone, and caused danger.

The composition lead piping used for gas distribution is

made of scrap lead and antimonial lead, which contains impurities rendering it dangerous to employ it for water distribution; it is usually very hard, and is made thin and light. This piping is frequently tinned when leaving the press, adding about six shillings a ton to the cost. The tin is applied to the lead from a cup round the die from which the tubing rises.

Tin is one of the oldest, as it is one of the most useful and beautiful of metals. It is obtained from an ore called tin stone, usually found in veins running through primitive rocks, in Cornwall, Malacca, Banca, Mexico, and Australia. It is sometimes found in a very pure state in alluvial soils where it was carried by water and deposited; it is then called stream tin. The original veins can be generally traced out by following up the likely course taken by the stream.

The metallurgical operations to extract the metal from the ore somewhat resemble those in the case of lead ores—stamping and washing, to remove the earthy and lighter portions; roasting, to decompose pyrites and get rid of arsenic and sulphur; washing, to dissolve cupric sulphate and carry off ferric oxide; reduction, to separate the tin from oxygen and earthy matter; and refining, or liquation, to purify for use.

In the latter operation the tin is heated till it begins to fuse, on the bed of a reverberatory furnace. The purer tin, being more fusible, gradually melts out, leaving an alloy which has a higher fusing-point; this, when remelted, forms the inferior class called block tin.

The purer metal is then put through a further refining process, and the purest portion of all becomes so brittle that it will split into irregular fragments, known as grain or dropped tin. This condition of tin is a guarantee of purity.



Tin fuses at  $442^{\circ}$ ; its specific gravity is 7.29. Tin is a white metal, with a high metallic lustre like silver. It has a yellowish tint, has a peculiar taste and odour when rubbed or held in a warm hand, is very soft and malleable, but of low tensile strength; at  $212^{\circ}$  is ductile, and may be drawn into wires. If a bar be bent it emits a crackling sound, and becomes hot at point of flexure if bent several times back and forward. If a little lead be added to the tin, the crackle or tin cry will not occur; it is therefore a rough test of purity.

Zinc, till lately chiefly seen in London in the frightful forms with which frantic chimney doctors make the London sky-line hideous, is a metal likely to be more frequently met with by plumbers than was formerly the case, owing to great improvements in its manufacture. It is suitable for roof-work, owing to its qualities of lightness and durability, combined with the universal latter-day cheapness, a quality to which plumbers also must perforce take heed.

Ingot zinc is also known on the market as spelter. It is produced from calamine, or carbonate of zinc, so called from its peculiarity of adhering after fusion in the form of reeds to the base of the furnace; from blende, or sulphide of zinc, or black jack, as the miners call it; and from red zinc ore, or the oxide of zinc.

These ores are found in England, America, Silesia, Belgium, Sweden, and Spain; they are crushed between rollers and roasted in furnaces by methods differing in each country. Calamine is more easily smelted than blende. Blende requires great care and much time in order to extract all traces of galena, usually mixed with blende, as the presence of lead is not only found to destroy the crucibles used in the reduction of the metal, but also renders the zinc

too brittle to roll into sheets. In England the roasted ore is mixed with half its weight of powdered coke or charcoal in crucibles of special construction, covered and placed in circular furnaces, three on each side of fire-bars, and the molten zinc is received in iron vessels placed underneath discharging tubes leading from the crucibles. This metal is remelted, and when the oxide scum is removed it is cast into ingots. When required for rolling into sheets these ingots are again melted at a low temperature and cast into plates of suitable form, which are passed through the rolls at a temperature of  $220^{\circ}$ .

Zinc, or spelter, is a hard, bluish-white metal. At temperatures of  $60^{\circ}$  to  $100^{\circ}$  it is brittle, showing a crystalline fracture if broken; but at temperatures from  $212^{\circ}$  to  $300^{\circ}$  it becomes very malleable and ductile, easily wrought. Curiously, at  $410^{\circ}$  it again becomes brittle enough to pulverize; and at  $793^{\circ}$  zinc fuses. Its specific gravity is  $6.86^{\circ}$ .

Zinc tarnishes rapidly on exposure to moist air; a film of oxide forms on the surface, but this corrosion prevents further corrosion and protects the metal from decay. Near the sea, and in cities where the air contains acids, zinc is seriously attacked. Soot also is injurious in its effects when lying in contact with zinc. These points should be remembered.

Sheet zinc of good quality is of uniform colour, and tough enough to admit of frequent bending without splitting. If sheet zinc is dark or blotchy it is of inferior quality, and should be rejected.

Zinc expands and contracts under changes of temperature more than either lead or copper; free play must, therefore, be provided for it in roof-work. It should not be laid in contact with iron, copper, or lead, as voltaic action may rapidly destroy it when moisture is present. Zinc sheets

are also liable to burn fiercely if they reach a red heat, and in event of a fire occurring a zinc roof will add fuel to the flames.

Zinc is rolled in sheets eight feet or seven feet long, and three feet wide; it can be rolled any length up to twelve feet.

The thicknesses recommended for roof-work are known on the zinc-gauge (by which gauge they should be specified) as Nos. 15 and 16, corresponding with Nos. 19 and 20 on Birmingham wire-gauge.

The soldering of zinc on roofs should be avoided. Special flashings and end pieces for roof rolls are supplied, and special slips and fasteners to render the use of solder unnecessary, and give freedom for contraction and expansion.

Copper, a metal known to the ancients, appears to have been wrought in Cyprus by the Greeks, and hence its name. Copper is sometimes found, in its native state, crystallized in cubes, but usually it is in combination with sulphur, oxygen, and arsenic. The commercial copper is almost exclusively derived from the sulphurets.

The most common ore of copper is the copper pyrites, but there are several ores of copper. They are found in Cornwall, Chili, Cuba, Spain, Australia, America, Saxony.

The well-known yellow copper ore is a combination of sulphuret of copper with sulphuret of iron.

Copper is remarkably malleable and ductile; it may be beaten into thin sheets or drawn out into fine wire. In tenacity it is inferior only to iron amongst the metals. It has a peculiar taste, and under friction emits an unpleasant odour. Its density varies from 8.78 for cast copper to 8.96 for rolled copper. Daniell has placed the melting-point at 1,996° F., when it attains a strong red heat. Pouillet gives 2,050° as the fusing-point. At a white heat it vaporizes.

Copper does not oxidize in dry air at ordinary temperatures. Acids act strongly on copper.

Verdigris is a subacetate of copper. It forms rapidly when copper is in contact with cloths dipped in vinegar.

Dilute sulphuric and muriatic acids act little on copper, but dilute nitric acid dissolves it quickly.

Blue vitriol, or sulphate, is one of the most important salts of copper.

Green vitriol, or copperas, is a protosulphate of iron.

Swansea, in Wales, is the great centre for the smelting of copper. The metal is hard, tenacious, ductile, and malleable.

Copper is one of the best conductors of heat and electricity. It oxidizes slowly in moist air, becoming covered with a verdigris film, forming a protective coating over the metal. Exposure to dry air or pure water has no special effect on copper; but sea-water, and water with chlorides in solution, and spring and river water attack it in many cases, so that it is not always safe to employ copper pipes, unless tinned inside, to convey water for culinary purposes. Nor is it a safe metal to use for soil-pipes or in sanitary appliances, the copper pans of pan closets corroding rapidly.

Copper is used in good-work for covering flats and gutters.

Sheet copper is rolled usually in sizes 4 feet  $\times$  2 feet and 4 feet  $\times$  3 ft. 6 in. 12, 16, and 20 ounces to the foot, corresponding with Nos. 26, 24, and 22 Birmingham wire-gauge, are the sizes usually specified for roofs and gutters.

Plumbers should devote attention to working copper pipes, bending, screwing, and fitting, as they are now being much used for hot-water supply, and are displacing lead pipes.

Having thus briefly referred to the metals which the plumber is chiefly concerned with as materials for work, we may just glance at the alloys or mixtures of the metals.

These mixtures sometimes exhibit properties so different from those of the metals composing them, that the alloy may be regarded as a new metal. For instance, copper and tin are malleable separately, but an alloy of two parts of copper and one of tin, known as speculum metal, is so hard that it cannot be cut with steel chisels, and is as brittle as glass, and its tensile strength is only one-fifth that of tin, and one-fiftieth that of copper.

Again, an alloy of nine parts of copper and one of tin, known as gun-metal, is harder than copper, and its hardness is increased by adding more soft tin. It is more fusible than copper, but cannot be rolled or drawn out.

In making alloys it is best to melt the least fusible metal first, adding the others, and keeping them stirred if of different specific gravity.

Hard solders, soft solders, pewter, bell-metal, type-metal, gun-metal, brass, bronze, are all alloys.

Hard solders can only be used with metals which will endure the heat at which hard solders fuse. For soldering brass-work the alloy is made of one part of zinc spelter to one of copper; for soldering iron and copper it is made of two parts of zinc spelter to three of copper. These solders are usually granulated by pouring, when melted, through a bundle of twigs into water. For soldering silver, hard solder is made of one part of copper to two, three, or four of silver—generally used for very fine joints in iron, steel, brass, or gun-metal, as well as for silver and light-coloured metals.

Soft solders, which melt at low temperatures, are alloyed in various proportions for the use of plumbers and tin-workers, as already described.

Plumbers' solder, of such good quality as to be fit for stamping by the Plumbers' Company, is made in proportions of two parts of lead to one of tin; if any variation be

made, let it be a small extra percentage of tin, as in working the solder picks up lead from the lead on which it is used, decreasing its fusibility. The solder pot should be capable of holding two hundredweight of metal. Into this put first your lead, as pure as you can get it—pig lead if you want specially good solder, though when making solder it may be well to use up your old scrap lead. When your lead is well melted, stir it and remove the scum, then add half the weight of purest ingot tin, and when it has nearly melted you can assist fusion by adding a little resin. Keep it quietly stirred till hot enough to ignite paper, or make wood smoke quickly when plunged in it, and then cast it in any convenient form of mould you may desire. This will be better solder than the quality usually purchased from lead merchants. By heating the solder more than usual a bloom is thrown up by the tin oxidizing, but this is not desirable. When you pour out solder and let it cool, spots should appear on the top about an inch apart; if the spots are very close the tin is probably too abundant in the alloy.

Old solder joints may be cut off old lead pipes and melted up again, when the workman is experienced in making solder. It saves tin; but when the time expended in cutting off the joints and the extra time in getting the proportions of tin and lead right in melting is taken into account, and added to the fact that the solder will not be so good as if made from all ingot tin and lead, the odds of profit and loss are against the practice. Solder of this class fuses at about 440° F.

Fine solder has proportions of half tin and half lead, fusing at 370°. It can be tested by pouring out in flat strips, and when cool, bending it close to the ear, it should emit a very slight creaking sound. If the creaking be too marked, it is too fine.

Fine blow-pipe solder is made of  $1\frac{1}{2}$  parts of tin to 1 of lead, fusing at  $334^{\circ}$ . It is run out on a clean slab, in long strips, about a quarter of an inch in diameter, from a ladle having a small hole drilled in the spout to get the size even.

A slight addition of bismuth renders solder extra fusible.

Solder is injured by impurities. Zinc will make it too brittle to work at all, and the solder must then be purified by burning the zinc out, letting the pot get nearly red-hot, till the zinc burns off in vapour and scum, and skimming it, but not stirring up the lead while red-hot. Add a little sulphur, which will bring up more scum, which remove. Let solder cool, adding tallow, and mixing it up when nearly cool enough to work with, adding also a little resin and pure tin.

Solder should be stirred by the plumber in the pot always before taking a ladleful out, as the lead and tin are apt to lie in layers, owing to difference in specific gravity.

Plumbers' students should practise carefully the effects produced on their solders by adding lead and tin in various proportions. The teacher should assist them in class with practical advice, and, pointing out the effects, explain the causes. Plumbers do not gain by complaining of the quality of solder served to them; they should know how to adjust it themselves. Keep zinc at a respectful distance from your solder. In making alloys like solder the melting-pot should be red-hot (a white heat is better), and those metals placed in it which require the most heat to fuse them.

Put the metals in the melting-pot in strict order, following exactly the different fusing-points from the highest degree of temperature required down to the lowest, in regular sequence, and being especially careful to refrain from adding the next metal until those already in the pot are completely melted.

When the metals fused together in the crucible require

very different temperature to melt them, a layer of charcoal should be placed upon them; or, if there is much tin in the alloy, a layer of sand should be used.

The molten mass should be vigorously stirred with a stick, and even while pouring it into another vessel the stirring should not be relaxed.

Another hint is to use a little old alloy in making new, if there is any on hand, and the concluding word of caution is to make sure that the melting-pots are absolutely clean and free from any traces of former operations.

Plumbers' smudge is of some importance in making joints. The ugly, unfinished appearance of joints so often observed is frequently caused by the use of badly made smudge. Some plumbers consider the quality of the smudge they use as beneath their notice, but it is only by careful attention to such details in plumbing work that neat and sound workmanship is attained.

• Good smudge will dry quickly of a dead black shade, contrasting well with the bright grey shade of lead. When dry it will not rub off easily, nor will it chip or peel off, and it will not be sticky or greasy.

Good smudge is made by mixing carefully one part by weight of chalk and two parts of lampblack, grinding them well together with a pestle in a small cast-iron mortar, or on a slab with a palette knife, then adding a little melted size, and mixing all into a paste. Now take the smudge-pot, half fill it with equal parts melted size and water, pour in the paste, stirring all carefully, and warm up the whole in a glue-pot on a fire or stove, thus not allowing the temperature to rise quite to 212° F., the boiling-point.

As the quality of the materials will vary, the smudge when made should be tested in the following way: Take



a piece of sheet lead, previously cleaned, and apply the smudge evenly with a paint-brush; then dry it at the fire. Then gently rub the smudge to see if it adheres firmly. If it rubs off, more size must be added. If it chips or peels off, water must be added, and all heated again, continuing the tests till the smudge is found right for working. Porter, sometimes added to smudge, renders it sticky, and is not recommended.

Fluxes are used to assist the flow of melting metals, and are specially useful to plumbers in soldering operations. When metals are in process of heating or melting they are liable to attack from the air, which coats them with a covering of oxide, checking the fusion of the metal and preventing combination as an alloy. This effect may be observed in the scale which forms on copper in soldering irons, and in the dross which floats on molten lead or solder. Fluxes are used chiefly to stop the formation of this oxide or rust, by excluding the air from the surface of the metal.

Fluxes act by cleansing the metallic surfaces they are suitably applied to, by preventing formation of oxides, and by assisting the flow and combination of the molten metals in soldering, or welding, or alloying.

Spirits of salts, muriatic acid, or hydrochloric acid are suitable fluxes for soft soldering. They require to be prepared specially by dissolving in them clean clippings of zinc, which at once cause an evolution of gas, accompanied by ebullition; when this action ceases, the flux is ready for use as muriate or chloride of zinc, technically known as killed spirit.

This flux must be carefully wiped away after soldering any metal liable to rust.

In soldering zinc the surface of the zinc must be clean

and bright, when killed spirits are used; crude spirits of salts may be used for zinc which is dull, as it cleans the surface, and in doing so becomes chloride of zinc.

Resin or chloride of zinc are used as fluxes in soldering tinned iron.

Resin, plain or mixed with oil, may be used as a flux for soft soldering bright clean surfaces, but it leaves a sticky residuum, which, however, does not cause rust. It is used for soldering lead and tin pipes.

Tallow, or touch, as it is technically called, is used by plumbers as the best flux for lead soldering; it preserves the bright shaved lead from the tarnish or oxide which would form at once unless touch was applied to the surface.

Gallipoli oil is the usual flux for pewter soldering.

Borax or sal-ammoniac is used as the flux for hard soldering, and for iron and steel welding.

Sal-ammoniac or chloride of zinc for soldering copper and brass.

## CHAPTER XI.

### PLUMBERS' TOOLS.

THE plumber is known by his tools and by their condition, as is his constant companion, the carpenter.

The shop fixtures, such as benches, casting-table, melting-pot, stoves, etc., and the shop tools, such as vices, stocks and dies, screwing machines, lead-burning machines, lathes, mandrels, etc., are provided by employers. The plumber is required to provide his own kit of handicraft tools—they are his personal property; many of them he makes with his own hands, others he purchases out of his savings, but all demand from him constant care to maintain their condition clean, sound, and fit for work—the carpet wrapper, for carrying tools to the jobs; the tool-chest, to hold the tools carefully ready for service.

The plumber's irons are required of various sizes: the larger to suit heavy roof-work and cistern lining, and smaller handy sizes for joint-making. These should be kept free from scale and dirt always.



FIG. 364.—Plumber's solder-iron.

The hatchet-shaped copper bit, fixed in an iron holder, with wooden handle, should be tinned bright on edge. When tinning, let the bit be as cool as possible, using whatever flux you intend to use in actual work.

The straight copper bit must be heavier than a tinplate worker's bit—not less than four and a half pounds of copper.

The solder-pot with iron handle, shaped to stand steady, and not of a kind to let solder spill out easily in use.

The splash-sticks are best made of iron.

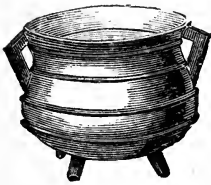

FIG. 365.—Solder-pot.



FIG. 366.—Plumber's ladle.

The ladles of sizes suited to the work in hand, selected for handiness, and flattened underneath to keep them steady when set down.

The solder-wiping cloths, made of ticking or fustian, are best sewn together. They should not be too thin.



FIG. 367.—Shave-hook.

The shave-hooks are wanted in two sizes straight and two others shaped and bent, for shaving in awkward corners where straight hooks cannot work. Shave-hooks should be kept very carefully.

The gauge-hook is required for shaving edges parallel.

The plumber's hammer may be left to choice; but it should be a good one, of fair weight to deliver a blow in driving hooks.



FIG. 368.—Bossing mallet.

The dummies must be made in various forms to beat the dents and dinges out of bends and traps. The handles are generally  $\frac{3}{8}$ -inch iron pipe, and the heads cast on the tinned end of the tube in sand moulds. Some dummies have cane handles.

The bossing mallet, with hardwood cone or egg-shaped head.



FIG. 369.—Chase wedge.



FIG. 370.—Mallet.

The chase wedges. The common mallet.

The dressers should be made of hornbeam, with well-set-back handles, for dressing into angles.



FIG. 371.—Tampin.



FIG. 372.—Dresser.

The conical boxwood tampins, or turnpins, for opening pipe-ends.

The flapper, like a square trowel, is made of sheet lead, about 12 inches by 6 inches, formed into a handle for striking bumps out of sheet lead in laying.

The plane, for edging sheet lead.

The square is made of iron, and marked as a rule in inches and eighths.

The mandrels, made slightly taper, of soft wood, about six to ten feet long, for turning soil-pipes on, are generally supplied by employers.

The straight-edge should be made of well-seasoned wood, quite true, for marking straight lines and testing edges.

The plumber's knife, strong, for cutting lead and trimming.

The plumber's rasp, for preparing edges for jointing, should not be coarse in grain.

The long-handled drawing knife, for cutting long cuts in sheets of lead for roof-work.

The turnscrew should always be well chosen, strong, not too wide in the point, for taking down mahogany and other casings neatly. A small one also is useful.

The screw-wrench, for couplings and nuts of boilers, cannot be too well made.

The iron bolt or tommy, for dressing lead in making branches, etc.

Two bradawls, two gimlets, one pliers for cutting wire, one brace and bits.



FIG. 373.—Cutting pliers.

The compass, for making curves and circles.

The calipers, for measuring thicknesses and diameters.

The blowpipe in various forms, for jointing and soldering.

The spirit level and plumb-line, always required.

The cramp, for holding two ends of pipes together for wiping a joint.

The smudge or soil-pot, made of copper, and its brush.

The plumber's saw, about sixteen inches in the blade, for cutting lead pipe across.

Three caulking tools of different thickness, for jointing iron drain and soil pipes.

Plumber's blowpipe torches, used with methylated spirits or benzoline, are very trying to the workmen, and only advantageous in making joints in some place where a fire cannot be had.

The self-acting blowing lamps, with spirits in a boiler, heated by a small lamp, generate a powerful flame. The valve needs attention to keep it free and prevent accidents from explosion. The solder must be used in strips with

these lamps. They are more useful for jointing than for roof or cistern work.

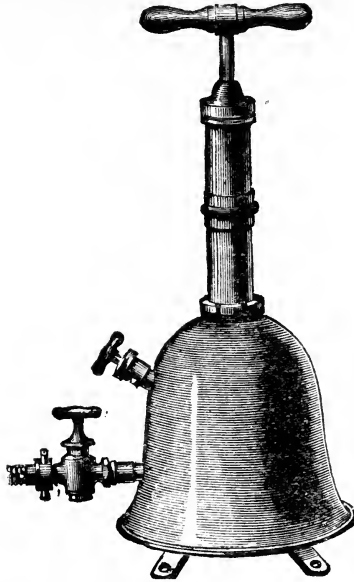

FIG. 374.—Plumber's pump for clearing service-pipes.

The plumber's forcing-pump, for clearing choked or air-bound pipes. With this useful pump (Fig. 374), by closing the stop-cock, and working the handle and piston, a great pressure can be obtained in the copper bell-shaped container. This concentrated force can be suddenly discharged into obstructed pipes to clear them. About two feet of strong indiarubber hose is also needed to attach to couplings.

The plumber's force-pump, handy to carry and useful.

The forcing cup, for clearing water-closet traps.

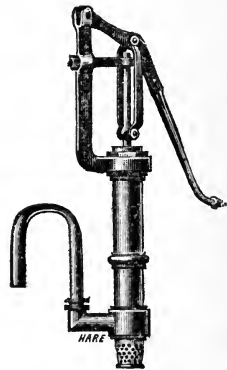

FIG. 375.—Plumber's force-pump.



FIG. 376.—Steam or gas-pipe tongs.

The gun-barrel tongs, of two sizes.



FIG. 377.—Gas-pliers.

The gas-pliers, for brass couplings and unscrewing gas-burners.



FIG. 378.—Wrench for gratings.

The stocks and dies,  $\frac{1}{8}$  inch to 2 inches.

The shears, for cutting sheet zinc, copper, or brass.

The list of tools here given is intended as a guide to enable young plumbers to try systematically to get together as complete a collection as possible. A plumber never knows what class of work he may be called on to do, but he should aim at being ready for anything.

It is not at the moment of commencing a plumbing job that the plumber should begin to seek for tools. He cannot take all the tools in the list to daily jobs, but he ought to be provided with them in long country jobs.

We must not forget that, although the best kind of tools help a plumber in his work, yet a good plumber, to handle



them well, is much more important. Tools are to be bought for money, but plumbers must be trained and educated to use them.

3 irons.	3 bradawls.
2 copper bolts.	2 gimlets.
2 copper bits.	1 screw-wrench.
2 solder-pots.	2 iron bolts.
2 ladles.	1 pliers.
1 splash-stick.	1 brace and bits.
1 pouring stick.	1 compass.
4 shave-hooks ; 2 straight, 2 shaped.	1 calipers.
1 gauge-hook.	2 blowpipes.
1 hammer.	1 cramp for pipe joint.
1 bossing mallet.	1 pair of shears.
1 plain mallet.	Stocks and dies.
6 dummies.	2 gas-pliers.
3 dressers.	2 gun-barrel tongs.
3 turnpins.	1 force-pump.
1 flapper.	1 forcing cup.
1 wedge.	1 blowing lamp.
1 plane.	1 solder cloth.
1 square.	1 carpet.
3 mandrels.	1 saw.
1 straight-edge.	1 soil-pot and brush.
1 knife.	3 caulking tools.
1 drawing knife.	1 spirit-level.
1 rasp.	1 palette knife.
2 turnscrews.	1 wrench for gratings.

The renaissance of the plumbing craft has created a demand for first-class journeyman plumbers to carry out first-class work. To attain the highest rank as such nowadays, a man must have commenced at the foundation. The very utmost use of his opportunities at school is essential to give a solid groundwork of primary education, and this is now placed within easy reach of all boys, but is difficult to attain in later life. Next, as a lad, he must work steadily under a good master as an apprentice and improver, during a term of seven years at the very least.

During his apprenticeship he must contrive to attend

technical classes in plumbing and science classes connected with plumbing.

He should pass the examinations both under the Science and Art Department and under the City and Guilds of London Technical Institute, securing thus his full Technological Certificate.

He should then claim his right to registration as a journeyman plumber from the Plumbers' Company. He will then be qualified to commence his career as a fully trained journeyman plumber.

In the first place, he will be an honest man all round, scrupulously sharp in keeping time, and protecting his employer's interests against waste of either the time or the material used and paid for by his employer.

The plumber whose heart is in the right place—that is, in his work—steps out bravely with a will, looks every inch a workman, and is proud to know it; his mate or assistant will also share his spirit, for there is a magnetism in it that attracts. As iron sharpeneth iron, so a man sharpeneth the countenance of his friend. He will be a gentleman at heart also, as every plumber ought to be, considering the wishes and feelings of those about him in his daily round of work, being careful not to injure property or make his presence in any dwelling disagreeably felt.

The model journeyman plumber must add many other qualifications to these if he is to take front rank.

His hands must first be the hands of a plumber, adroit in all manipulation of lead and solder.

As a foreman he will be prepared to meet the architects. He will find greater clearness and detail in their plumbing specifications than, no doubt; but he will also be more frequently invited in person to receive instructions, and will be expected to be ready to point out possible improvements, and to explain practical points, to hear practical

difficulties stated, and to suggest the best means to overcome them.

As a foreman, or as a master, he must know the values of material and work, so as to draw up and price out quantities for estimates.

He must understand the chemical and physical qualities of the various metals, and their uses in the trade.

He must be acquainted with the mixing of alloys, and know their fusing-points and working qualities.

He must be prepared to advise on occasions as to the best means of obtaining suitable household water in any district, to calculate the required quantities, and the proper dimensions for store tanks and conduits.

He must be able to recommend the best form and the proper dimensions of pumps, hydraulic rams, and pumping engines, to fix them, and to calculate the quantity of water each is capable of raising to given heights with given powers.

He must be a ready draughtsman, so as to convey his instructions clearly to workmen.

Syphonage and momentum in traps he must be able to conquer. Planning, laying, flushing, and disinfecting of drains, he will be required to understand.

Finally, we hope that the model plumber may obtain so honourable a position that, without fear of consequences, he may be able to decline to carry out faulty or insufficient plumbing work, no matter who may specify it or require it executed.

In closing these chapters let us once again recall the fact that, as modern plumbing and drainage exert a more powerful influence over the health and happiness of our

fellow-men than any other handicraft, so also a greater responsibility rests upon us, and upon all connected with these crafts, to do our whole duty to the public and to each other, whether as teachers, as masters, as journeymen, or as students.

Recent attention to sanitary reform, in which good and sound plumbing and drainage work takes the most important place, has saved the lives, improved the health, and increased the happiness of hundreds of thousands of the people of our land; but we must also admit that sorrow, suffering, and death can still be traced to shameful ignorance and neglect of sound sanitary plumbing and drainage work, both on the part of the public and on the part of some who undertake the responsibility of ministering to them in such vital matters.

The technical education of plumbers is of double value when it is given and received by those who realise the greatness of their moral responsibility in following this handicraft, and the vital importance of securing, by all means in their power, good arrangement and sound work in the plumbing and drainage of the dwellings entrusted to their care.

The arts of decorating and of furnishing houses, which receive the most ample consideration, both from the public and from the craftsmen concerned, involve mere questions of taste and luxury; the arts of plumbing and drainage, therefore, involving the life and health, and consequently the happiness of whole families and communities, should occupy a higher and more important position than they have yet been given.

The claims of plumbers, whether journeymen, foremen, or employers, to this noble grade, depend on the manner in which they individually realise their responsibility, and act upon their professions. It is one of the great objects

of the City and Guilds of London Institute, not merely to teach technicalities that may better be learned in the workshop or at the bench, but to encourage the teachers of plumbing, and to stimulate the younger students and craftsmen to concentrate their faculties, and to join all together in one bond of union to elevate themselves and each other, and by their united efforts to raise once more the noble art and handicraft of plumbing to the highest attainable position of honour and of usefulness.

## CHAPTER XII.

### PLUMBERS' RULES AND TABLES.

#### USEFUL RULES FOR PLUMBERS.

GIVEN the diameter of any circle, to find the circumference—  
Multiply diameter by 3·1416.

Given the diameter of any circle, to find the side of an  
equal square—  
Multiply diameter by ·886226.

Given the diameter of any circle, to find the side of an  
inscribed square—  
Multiply diameter by ·7071.

Given the diameter of any circle, to find the area—  
Square the diameter and multiply by ·7854.

Given the circumference of any circle, to find the  
diameter—  
Multiply circumference by ·31831.

To find the area of any triangle—  
Multiply the base by half the perpendicular.

To find the area of any ellipse—

Multiply the conjugate axis by  $\cdot 7854$ , and the product by the transverse axis.

To find the surface of any cylinder—

Multiply the circumference by the length, and add the area of both ends.

To find the surface of any cone—

Multiply the circumference of the base by one-half of the slant height, and add the area of the base.

To find the surface of any sphere—

Multiply the square of the diameter by  $3\cdot 1416$ .

To find the solid contents of any cylinder—

Multiply the area of one end by the length.

To find the solid contents of any sphere—

Cube the diameter and multiply by  $\cdot 5236$ .

To find the solid contents of any cone or pyramid—

Multiply the area of the base by one-third of the perpendicular height.

To find P (pressure in pounds per square inch) from any given head of water—

Multiply H (the head or height of water in feet) by  $\cdot 433$ .

$$H \times \cdot 433 = P.$$

To find H (the head or height of water in feet) from P (any given pressure in pounds per square inch)—

Multiply the given pressure in pounds per square inch by 2.31.

$$P \times 2.31 = H.$$

To find the contents of a cylindrical water tank approximately in gallons—

Square  $D$  (the diameter in feet), and multiply by 5, and again by  $H$  (the number of feet in height).

$$D \times D \times 5 \times H = \text{gallons.}$$

To find the contents of any pipe or drain—

Square  $d$  (the diameter in inches) for  $W$  (the weight of water in pounds per yard of pipe). Divide by 10 for  $G$  (the number of gallons per yard of pipe).

$$d \times d = W \div 10 = G.$$

To find the weight of water in any large tank in tons when full—

Reduce the contents to cubic feet, and divide by 36 for tons weight.

Thus in a tank 20 feet  $\times$  12 feet  $\times$  6 feet = 1,440 cubic feet,  $1,440 \div 36 = 40$  tons of water when full.

To find the weight of iron per foot—

A square foot of cast iron 1 inch thick weighs  $37\frac{1}{2}$  lbs. To find what a square foot of any other thickness will weigh, multiply  $37\frac{1}{2}$  by the thickness in inches or fractions of an inch.

A square foot of rolled wrought iron 1 inch thick weighs 40 lbs. To find the weight of boiler-plates or sheet iron per square foot, multiply 40 by the decimal of an inch in thickness the required plates are to be.



To find the weight of castings from the pattern—

Multiply weight of deal pattern by 17 for cast iron.		
„ „	18	„ brass.
„ „	19	„ copper.
„ „	25	„ lead.

To find the weight of iron castings—

Find the solid contents in inches, and multiply them by .26, and it will give the weight in pounds. For rough calculations it will do to divide the cubic inches by four and call the answer pounds.

#### USEFUL TABLES FOR PLUMBERS.

The weight of pure water at 62° F. should be well known to plumbers:—

One cubic inch weighs 252½ grains, or .03612 pound.

Four cubic inches weigh 1,010 grains.

One cubic foot weighs 1,000 ounces.

One cubic foot weighs 62.3106 pounds, but is taken as 62½ pounds for all practical purposes.

One cubic foot of water is equal to 28 litres.

Sixteen cubic feet weigh 1,000 pounds.

Thirty-six cubic feet weigh 1 ton.

One cubic yard weighs ¾ ton.

One cubic metre weighs 1 ton nearly.

One cubic metre contains 1,000 litres.

One cubic foot contains 6.23, or 6¼ imperial gallons nearly.

One cubic metre contains 35.317 cubic feet, or 220 gallons.

One gallon weighs 10 pounds.

One gallon contains 277.274 cubic inches.

One gallon contains .16046 cubic foot.

One gallon contains 4.543 litres.

One litre is equal to .26418 gallon, or 61.028 cubic inches.

One hundred litres is equal to 22¼ gallons nearly.

One ton contains 224 gallons, or 36 cubic feet.

One hundredweight contains 11.2 gallons, or 1.8 cubic feet.

TABLE OF THE PRESSURE OF WATER IN POUNDS PER SQUARE INCH  
UNDER VARIOUS HEADS IN FEET.

Feet.	Pounds.	Feet.	Pounds.	Feet.	Pounds.
0	0	34	14·73	68	29·47
1	·4335	35	15·17	69	29·91
2	·865	36	15·6	70	30·34
3	1·3	37	16·03	71	30·77
4	1·73	38	16·47	72	31·21
5	2·16	39	16·9	73	31·64
6	2·6	40	17·34	74	32·07
7	3·03	41	17·77	75	32·51
8	3·46	42	18·2	76	32·94
9	3·9	43	18·64	77	33·38
10	4·335	44	19·07	78	33·81
11	4·76	45	19·50	79	34·24
12	5·2	46	19·94	80	34·68
13	5·63	47	20·37	81	35·11
14	6·07	48	20·8	82	35·54
15	6·5	49	21·24	83	35·98
16	6·93	50	21·67	84	36·41
17	7·37	51	22·1	85	36·84
18	7·8	52	22·54	86	37·28
19	8·23	53	22·97	87	37·71
20	8·67	54	23·4	88	38·14
21	9·1	55	23·84	89	38·58
22	9·53	56	24·27	90	39·01
23	9·97	57	24·7	91	39·44
24	10·4	58	25·14	92	39·88
25	10·83	59	25·57	93	40·31
26	11·27	60	26·01	94	40·74
27	11·7	61	26·44	95	41·18
28	12·13	62	26·87	96	41·61
29	12·57	63	27·31	97	42·05
30	13	64	27·74	98	42·48
31	13·43	65	28·17	99	42·91
32	13·87	66	28·61	100	43·35
33	14·3	67	29·04		

DISCHARGE OF WATER IN GALLONS PER MINUTE FROM STRAIGHT CYLINDRICAL PIPES FLOWING FULL UNDER VARIOUS HEADS.

The first number given is from Neville's formula, and is generally greater than the second number, from Eytelweh's formula.

Diameter of Pipe in Inches.	RATIO OF HEAD TO LENGTH.												
	1. 1 in 1000.	2. 1 in 500.	3. 1 in 250.	4. 1 in 200.	5. 1 in 125.	6. 1 in 100.	7. 1 in 50.	8. 1 in 33.	9. 1 in 25.	10. 1 in 20.	11. 1 in 10.	12. 1 in 5.	13. 1 in 1.
3/8	..	..	..	..	..	.2 .24	.33 .33	.4 .42	.5 .48	.56 .63	.8 .75	1.2 1.07	2.9 2.4
1/2	..	..	..	..	.4 .4	.46 .49	.7 .69	.88 .86	1 .98	1.11 1.1	1.36 1.55	2.5 2.5	6 4.9
3/4	..	..	.75 .85	.9 .96	1.1 1.2	1.3 1.3	1.9 1.9	2.5 2.3	3 2.7	3.33 3.03	4.89 4.28	7 6	16.9 13.5
1	..	1 1	1.5 1.75	2 1.9	2.4 2.4	2.7 2.7	4 3.9	5 4.9	6 5.5	6.9 6.2	10 8.8	14 12	35 28
1 1/4	1 1	2 2	3 3	3.3 3.4	4 4	5 4.8	7 6.8	9 8.7	10 9.7	12 11	17 15	26 21	61 48
1 1/2	2 2	3 3	4.5 4.8	5 5.4	7 6.7	8 7.6	11 10.8	14 13.5	17 15.5	19 17	28 24	41 34	97 76
2	4 4	6 6	10 9.9	11 11	14 13	16 15	24 22	30 27	36 31	40 35	59 49	86 70	200 157
2 1/2	7 8	11 12	17 17	20 19	26 25	29 27	43 39	54 48	63 55	70 61	100 87	150 122	350 275
3	12 14	18 19	28 27	32 30	41 39	47 43	69 61	85 75	100 86	114 97	165 137	239 193	560
4	26 28	39 40	58 56	66 60	86 80	98 89	140 126	180 155	210 178	237 200	340 280	490 400	1160
5	46 49	69 69	104 98	118 109	150 140	170 155	250 220	300 270	370 300	418 350	600 490	870 700	2000
6	74 78	111 110	166 154	188 170	240 220	270 245	400 340	500 425	580 490	660 550	950 770	1390 1100	3260
9	212 214	317 300	468 430	530 480	680 600	770 676	1100 956	1400 1180	1600 1350	1850 1500	2680 2140	3870 3000	8970
12	446 440	663 620	980 870	1100 980	1400 1250	1600 1400	2300 1960	2900 2500	3400 2800	3840 3100	5550	8000	18500

Columns 1 to 5 are calculated for a length of 1000 feet. Columns 11 and 12 are calculated for a length of 10 feet.

VELOCITIES IN FEET PER SECOND, CALCULATED FROM NEVILLE'S FORMULA FOR WATER IN STRAIGHT CYLINDRICAL PIPES FLOWING FULL UNDER VARIOUS HEADS AND LENGTHS.

Diameter in Inches.	1. 1 in 1000.	2. 1 in 500.	3. 1 in 250.	4. 1 in 200.	5. 1 in 125.	6. 1 in 100.	7. 1 in 50.	8. 1 in 33.	9. 1 in 25.	10. 1 in 20.	11. 1 in 10.	12. 1 in 5.	13. 1 in 1.
$\frac{3}{8}$	.175	.28	.486	.5	.67	.77	1.16	1.47	1.73	1.96	2.9	7.02	10.2
$\frac{1}{2}$	.212	.34	.52	.6	.79	.91	1.37	1.73	2.04	2.3	3.4	8.2	11.9
$\frac{3}{4}$	.275	.44	.67	.77	1.02	1.16	1.73	2.18	2.56	2.9	4.25	10.2	14.75
1	.335	.52	.79	.91	1.2	1.37	2.04	2.56	3	3.4	5	11.9	17.18
$1\frac{1}{4}$	.385	.6	.91	1.04	1.37	1.56	2.31	2.9	3.4	3.85	5.63	13.4	19.33
$1\frac{1}{2}$	.435	.67	1.02	1.16	1.52	1.73	2.56	3.2	3.76	4.26	6.22	14.75	21.28
2	.522	.79	1.2	1.37	1.79	2.04	3	3.76	4.5	5	7.27	17.18	24.16
$2\frac{1}{2}$	.6	.91	1.37	1.56	2.04	2.3	3.4	4.26	5	5.63	8.2	19.33	27.84
3	.67	1.02	1.52	1.73	2.26	2.56	3.76	4.71	5.5	6.22	9.04	21.28	30.6
4	.8	1.2	1.79	2.04	2.65	3	4.4	5.5	6.5	7.27	10.55	24.16	35.6
5	.91	1.37	2.04	2.31	3.01	3.4	5	6.2	7.27	8.20	11.9	27.8	40
6	1.02	1.52	2.26	2.56	3.33	3.76	5.5	6.86	8.02	9.04	13.1	30.6	44.6
9	1.3	1.92	2.83	3.21	4.16	4.7	6.86	8.54	9.97	11.25	16.25	37.87	54.33
12	1.52	2.26	3.33	3.76	4.88	5.5	8.02	10	11.63	13.10	18.99	44	63

Columns 1 to 5 are calculated for a length of 1000 feet  
 " 6 to 10 " " 100 feet.  
 Columns 11 and 12 are calculated for a length of 10 feet.  
 Column 13 is calculated for a length of 1 foot.

APPROXIMATE QUANTITY OF WATER RAISED BY SINGLE-THROW PUMPS IN GALLONS WITH THIRTY STROKES PER MINUTE.

	9-inch Stroke.	10-inch Stroke.	12-inch Stroke.
2-inch . . . . .	3	3½	4
2½-inch . . . . .	4½	5½	6½
3-inch . . . . .	6½	7½	9
3½-inch . . . . .	9	10½	12
4-inch . . . . .	12	13½	16
4½-inch . . . . .	15	17	20
5-inch . . . . .	19	21	25

Two-throw and three-throw pumps will, of course, raise double and treble these amounts respectively.

TABLE OF BOILING-POINTS BY VARIOUS AUTHORITIES, DIFFERING FROM M. POUILLET'S EXPERIMENTS.

Substances.	Réaumur.	Centigrade.	Fahrenheit.
Alcohol boils at . . . . .	63°	78°	173°
Bromine „ . . . . .	50	53	145
Ether „ . . . . .	28	35	95
Ether, nitrous, boils at . . . . .	11	14	57
Iodine „ . . . . .	140	175	347
Olive oil „ . . . . .	252	315	600
Mercury „ . . . . .	280	350	662
Water „ . . . . .	80	100	212

INCREASE IN VOLUME OF WATER FROM 40° TO 500° F.  
(Water when heated above 212° is under high pressure.)

F.	Volume.	F.	Volume.
40° . . . . .	1·0000	212° . . . . .	1·0433
50 . . . . .	1·0004	230 . . . . .	1·0512
60 . . . . .	1·0012	250 . . . . .	1·0604
70 . . . . .	1·0023	275 . . . . .	1·0729
80 . . . . .	1·0038	300 . . . . .	1·0869
90 . . . . .	1·0055	350 . . . . .	1·1156
100 . . . . .	1·0074	400 . . . . .	1·1484
120 . . . . .	1·0121	450 . . . . .	1·1843
140 . . . . .	1·0175	500 . . . . .	1·2233
160 . . . . .	1·0238	550 . . . . .	1·2666
180 . . . . .	1·0307	600 . . . . .	1·3099
200 . . . . .	1·0384		

## TEMPERATURE AND PRESSURE OF STEAM.

F.	Pounds per Square Inch.	F.	Pounds per Square Inch.
212° .	0	281° .	35
216 .	1	287 .	40
219 .	2	292 .	45
222 .	3	298 .	50
225 .	4	302 .	55
228 .	5	307 .	60
230 .	6	312 .	65
233 .	7	316 .	70
235 .	8	320 .	75
237 .	9	324 .	80
240 .	10	327 .	85
250 .	15	334 .	90
259 .	20	341 .	105
267 .	25	347 .	115
274 .	30	352 .	125

## TABLE OF FREEZING-POINTS.

Substances.	Réaumur.	Centigrade.	Fahrenheit.
Bromine freezes at . . .	-16°	-20°	- 4°
Oil, anise " . . .	8	10	50
Oil, olive " . . .	8	10	50
Oil, rose " . . .	12	15	60
Mercury " . . .	-31·5	-39·4	-39
Water " . . .	0	0	32

## TABLE OF FUSING-POINTS.

Substances.	Réaumur.	Centigrade.	Fahrenheit.
Bismuth metal fuses at .	200°	264°	476°
Cadmium " . . .	248·8	315	592
Copper " . . .	874·6	1093	2000
Gold " . . .	961	1200	2200
Iodine " . . .	92	115	239
Iron " . . .	1230	1538	2300
Lead " . . .	255·5	325	617
Potassium " . . .	46	58	136
Phosphorus " . . .	34	44	111
Silver " . . .	816·8	1021	1870
Silver nitrate " . . .	159	198	389
Sodium " . . .	72	90	194
Steel " . . .	1452	1856	3300
Sulphur " . . .	72	90	194
Tin " . . .	173	230	442
Zinc " . . .	328	410	793

TABLE OF FUSING-POINTS OF VARIOUS ALLOYS IN DEGREES FAHRENHEIT.  
According to Pouillet's Experiments.

Degrees Fahrenheit.	PARTS BY WEIGHT.			Degrees Fahrenheit.	PARTS BY WEIGHT.	
	Lead.	Tin.	Bismuth.		Lead.	Tin.
201	1	1	4	367	1	3
212	5	3	8	372	1	4
212	2	3	5	381	1	5
246	1	4	5	385	1	2
286	0	1	1	466	1	1
334	0	2	1	504	3	1

According to Other Authorities.

Degrees Fahrenheit.	PARTS BY WEIGHT.			Degrees Fahrenheit.	PARTS BY WEIGHT.	
	Lead.	Tin.	Bismuth.		Lead.	Tin.
199	3	2	5	320	1	1
202	5	3	8	334	1	1½
202	3	5	3	340	1	2
204	1	1	2	350	4	10½
208	6	3	8	356	1	3
212	2	3	5	360	4	13
220	7	3	8	365	1	4
230	8	3½	8	370	4	17
240	8	5	8	380	2	11
250	8	7	8	400	11	8
260	9	8	8	420	7	4
270	3	2	2	440	2	1
280	13	8	8	450	17	8
290	7	7	4	470	5	2
300	2	1	1	480	7	2
310	5	6	2	482	3	1
320	13	12	4	530	15	2
330	7	6	2	550	12	1
	4	3	2 =	pewterers' soft solder.		
	1	2	1 =	,, ,,		

ORDINARY PROPORTIONS FOR GALVANISED-IRON TANKS IN FEET AND INCHES.

Gallons.	Long. Ft. In.	Wide. Ft. In.	Deep. Ft. In.
20	1 9	1 3	1 6
30	2 0	1 6	1 7
40	2 4	1 7	1 9
50	2 6	1 7	2 0
60	2 8	1 10	2 0
70	2 8	2 0	2 2

Gallons.	Long. Ft. In.	Wide. Ft. In.	Deep. Ft. In.
80	3 0	2 0	2 2
90	3 2	2 2	2 3
100	3 2	2 2	2 4
120	3 4	2 4	2 6
140	3 6	2 6	2 6
160	3 6	2 8	2 9
200	4 0	2 8	3 0
250	4 1	3 3	3 0
300	4 7	3 6	3 0

## WEIGHTS FOR CAST-IRON WATER-PIPES IN POUNDS PER YARD.

Bore.	Working Pressure not exceeding, per Square Inch—			
	50 lbs.	100 lbs.	150 lbs.	250 lbs.
1½-inch	14	18	21	24
2-inch	20	24	26	28
2½-inch	24	28	30	34
3-inch	30	33	37	42
3½-inch	36	40	46	50
4-inch	45	50	54	61
5-inch	66	70	77	88
6-inch	84	77	89	105

## WEIGHTS FOR CAST-IRON DRAIN-PIPES IN POUNDS PER YARD.

	Light.	Medium.	Heavy.	Extra Heavy.
3-inch	23	35	42	48
4-inch	30	42	56	66
5-inch	35	60	90	104
6-inch	40	82	112	130

## WEIGHTS FOR LEAD PIPES IN POUNDS PER YARD.

Light for vent-pipes; Medium for cold water; Heavy for hot water; Extra for high pressure.

Internal Diameter.	Lightest.	Light.	Medium.	Heavy.	Extra.
½-inch	—	3½	5	5½	6
¾-inch	—	4½	6	7½	9
1-inch	—	6	8	9½	12
1¼-inch	—	9	11	13	16
1½-inch	9	12	14	18	21
2-inch	12	15	18	21	23
2½-inch	15	18	21	25	30
3-inch	18	20	23	28	35



WEIGHTS FOR COPPER PIPES IN POUNDS PER YARD.

Internal Diameter.	$\frac{1}{16}$ -inch thick.	$\frac{1}{8}$ -inch thick.	$\frac{3}{16}$ -inch thick.	Internal Diameter.	$\frac{1}{8}$ -inch thick.	$\frac{1}{4}$ -inch thick.	$\frac{3}{8}$ -inch thick.
$\frac{1}{2}$ -inch	1 $\frac{1}{4}$	2 $\frac{3}{4}$	5	1 $\frac{1}{4}$ -inch	3	6	10
$\frac{3}{4}$ -inch	2	4	6 $\frac{1}{2}$	1 $\frac{1}{2}$ -inch	3 $\frac{1}{2}$	7 $\frac{1}{4}$	11 $\frac{1}{2}$
1-inch	2 $\frac{1}{2}$	5	8	2-inch	4 $\frac{1}{2}$	9 $\frac{1}{2}$	15

WEIGHTS FOR COMPOSITION GAS-PIPES IN POUNDS PER YARD.

$\frac{1}{4}$ -inch.	$\frac{3}{8}$ -inch.	$\frac{1}{2}$ -inch.	$\frac{3}{4}$ -inch.	1-inch.
$\frac{3}{4}$	1 $\frac{1}{4}$	2 $\frac{1}{4}$	4 $\frac{1}{2}$	6

WEIGHTS FOR LEAD-ENCASED BLOCK-TIN PIPES IN POUNDS PER YARD.

	$\frac{1}{2}$ -inch.	$\frac{3}{4}$ -inch.	1-inch.	1 $\frac{1}{4}$ -inch.	1 $\frac{1}{2}$ -inch.
For 20 pounds pressure	3 $\frac{1}{2}$	5 $\frac{1}{2}$	7 $\frac{1}{2}$	9	11
„ 100	4	6	8	10	12 $\frac{1}{2}$
„ 200	4 $\frac{1}{2}$	7	9	12	14

WEIGHTS FOR BLOCK-TIN PIPES IN POUNDS PER YARD.

$\frac{1}{2}$ -inch.	$\frac{3}{4}$ -inch.	$\frac{1}{2}$ -inch.	$\frac{3}{4}$ -inch.	1-inch.
$\frac{1}{2}$	$\frac{3}{4}$	1 $\frac{1}{4}$	2	3

TABLE OF GAUGE AND WEIGHT OF SHEET COPPER.

(Weight per Square Foot.)

Wire-gauge.	Weight. lbs. ozs.	Wire-gauge.	Weight. lbs. ozs.	Wire-gauge.	Weight. lbs. ozs.
No. 1	14 0	No. 11	5 10	No. 21	1 8
„ 2	13 0	„ 12	5 0	„ 22	1 6
„ 3	12 0	„ 13	4 8	„ 23	1 2
„ 4	11 0	„ 14	4 0	„ 24	1 0
„ 5	10 2	„ 15	3 8	„ 25	0 14
„ 6	9 4	„ 16	3 0	„ 26	0 12
„ 7	8 8	„ 17	2 10	„ 27	0 11
„ 8	7 12	„ 18	2 4	„ 28	0 10
„ 9	7 0	„ 19	2 0	„ 29	0 9
„ 10	6 4	„ 20	1 12	„ 30	0 8

TABLE OF GAUGE AND WEIGHT OF SHEET AND ROLL BRASS.

(Weight per Square Foot.)

Wire-gauge.	Weight. lbs. ozs.	Wire-gauge.	Weight. lbs. ozs.	Wire-gauge.	Weight. lbs. ozs.
No. 3	11 8	No. 18	2 8	No. 25	0 14
„ 6	8 12	„ 19	1 12	„ 26	0 12
„ 10	5 12	„ 20	1 10	„ 27	0 11
„ 12	4 12	„ 21	1 6	„ 28	1 10
„ 14	3 12	„ 22	1 4	„ 29	0 9
„ 16	2 12	„ 23	1 0	„ 30	0 8
„ 17	2 8	„ 24	0 15		

494 DOMESTIC SANITARY DRAINAGE AND PLUMBING.

TABLE OF VALUE OF NON-CONDUCTING SUBSTANCES, THE MOST EFFICIENT NON-CONDUCTOR BEING PLACED FIRST ON THE LIST.

Woollen swansdown . . . . .	6	Dried chalk . . . . .	24
Grey paper . . . . .	9	Cork . . . . .	29
Eiderdown . . . . .	10	Caoutchouc . . . . .	41
Cotton-wool . . . . .	11	Coke . . . . .	44
Calico . . . . .	13	Gutta-percha . . . . .	48
Mahogany sawdust . . . . .	18	Plaster of Paris . . . . .	92
Wood ashes . . . . .	22	Terra cotta . . . . .	192
Wood charcoal . . . . .	22	Glass . . . . .	210

TABLE OF WEIGHTS OF ROUND AND SQUARE BARS OF WROUGHT IRON PER FOOT LINEAL.

	$\frac{1}{4}$	$\frac{1}{2}$	$\frac{3}{8}$	$\frac{1}{2}$	$\frac{3}{4}$	$\frac{1}{2}$	$\frac{3}{4}$	$\frac{1}{2}$	$\frac{3}{4}$	$\frac{1}{2}$	$\frac{3}{4}$	1"	
Round . . . . .	·164	·256	·369	·502	·656	·831	1·025	1·241	1·476	1·732	2·011	2·306	2·62
Square . . . . .	·209	·326	·470	·664	·835	1·057	1·305	1·579	1·879	2·205	2·556	2·936	3·34

To find the weight of any of the above in other metals, multiply by ·93 for cast iron; by 1·02 for steel; by 1·15 for copper; by 1·09 for brass; by 1·47 for lead; by ·92 for zinc.

Thus 1 foot of 1-inch round iron weighs 2·62 lbs., and to find its weight in lead multiply 2·62 by 1·47 = 3·8252 lbs.; to find its weight in zinc, multiply 2·62 by ·92 = 2·4104 lbs.

TABLE OF WEIGHTS OF ONE SQUARE FOOT OF VARIOUS METALS IN POUNDS.

	$\frac{1}{16}$	$\frac{1}{8}$	$\frac{3}{16}$	$\frac{1}{4}$	$\frac{5}{16}$	$\frac{3}{8}$	$\frac{1}{2}$	$\frac{5}{8}$	$\frac{3}{4}$	1"	
Iron . . . . .	2·5	5	7·5	10	12·5	15	17·5	20	25	30	40
Steel . . . . .	2·6	5·2	7·8	10·4	13	15·6	18·2	20·8	26	31·2	41·6
Brass . . . . .	2·7	5·5	8·2	11	13·7	16·4	19·2	21·9	27	33	44
Copper . . . . .	2·9	5·8	8·7	11·5	14·5	17	20	23	28·5	34	46
Lead . . . . .	3·7	7·4	11·1	14·8	18·5	22·2	25·9	29·5	36·9	44	59
Zinc . . . . .	2·3	4·7	7	9·4	11·7	14	16·4	18·7	25·4	28	37

TABLE OF AVOIRDUPOIS WEIGHTS.

16 ounces = 1 pound; 28 pounds = 1 quarter; 4 quarters = 1 cwt.  
 20 cwts. = 1 ton; or 112 pounds = 1 cwt.; 2,240 pounds = 1 ton.  
 1 kilogramme = 2·20462 pounds.  
 1 gramme = 15·432349 grains.

## TABLE OF LINEAL OR LONG MEASURE.

12 lines = 1 inch ; 12 inches = 1 foot ; 3 feet = 1 yard.  
 2 yards = 1 fathom ;  $5\frac{1}{2}$  yards = 1 pole or perch ; 40 perches = 1 furlong.  
 8 furlongs = 1 mile ; 1,760 yards = 1 mile ; 5,280 feet = 1 mile.  
 1 inch = .0254 French metre ; 1 foot = .3048 metre ; 1 yard = .9144 metre.  
 1 French metre = 39.37079 inches, or 1.093633 yard.

---

## TABLE OF MEASURES OF CAPACITY.

2 pints = 1 quart ; 4 quarts = 1 gallon ; 2 gallons = 1 peck.  
 4 pecks = 1 bushel ; 8 gallons = 1 bushel.  
 1 pint = .020051 cubic foot, or .5679 litre.  
 1 gallon = .32092 cubic foot, or 4.543 litres.  
 1 bushel = 1.28367 cubic foot, or 36.347 litres.  
 1 litre = .26418 gallons, or 61.028 cubic inches.

---

## TABLE OF SQUARE MEASURE.

144 square inches = 1 square foot.  
 9 square feet = 1 square yard.  
 $30\frac{1}{4}$  square yards = 1 square perch.  
 40 square perches = 1 rood.  
 4,840 square yards = 1 acre.  
 160 square perches = 1 acre.  
 4 roods = 1 acre.  
 1 square metre = 1.19603 square yard.

---

## TABLE OF CUBIC MEASURE.

1,728 cubic inches = 1 cubic foot.  
 27 cubic feet = 1 cubic yard.  
 1 cubic foot = 6.23 gallons.  
 1 cubic foot = 28.3 litres or cubic decimetres.  
 1 gallon = 277.274 cubic inches.  
 1 gallon = .16046 cubic foot.

---

## CEMENTS (ORDINARY).

HYDRAULIC CEMENTS contain a larger proportion of silica, alumina, magnesia, etc., than hydraulic limes. They do not slake after calcination, and some of them set under water at a temperature of 65° in from three to five minutes; others require as many hours.

ROMAN CEMENT, which is only about one-third the strength of Portland cement, is made of a lime of a peculiar character found in England and France, derived from argillo-calcareous kidney-shaped stones termed "septaria," and when mixed thick it solidifies in a few minutes, either in air or water.

PORTLAND CEMENT is made from an argillo-calcareous deposit, which is burnt and ground up for cement in its natural state, without the addition of lime. When strong it is heavy, weighing 110 lbs. to the bushel. It is of a blue-grey colour, and sets slowly. Weak cement sets quickly, has too much clay in it, is of a brownish colour, and is relatively light in weight. The cleaner and sharper the sand, and the less water used in mixing the cement, the stronger it will be. At the end of one year after setting, 1 of sand and 1 of cement is about three-fourths the strength of neat cement.

---

MIXTURE FOR RUST JOINTS.—(1.) Clean iron borings, 97 parts; flour of sulphur, 2 parts; sal ammoniac, 2 parts. (2.) Clean iron borings, 97 parts; sal ammoniac, 1 part; flour of sulphur, 1 part. For use mix to a mortar consistence with water. (1.) Quick setting; (2.) slow setting.

MIXTURE FOR CAST-IRON RAIN-PIPE JOINTS.—(1.) Use a putty of equal parts of white and red lead. (2.) Use a putty of linseed oil and red lead.

A NON-CONDUCTING COVERING for steam-pipes, etc., is made by mixing equal parts of sawdust and low-priced black rye-meal with tepid water into a thick paste, to which

some waste hair may be added. The paste put on the pipes gets baked by the heat and forms a tough elastic crust, which adheres to the pipes without wire or other outside fastenings. Pipes exposed to the outside atmosphere in passing through yards, etc., must be painted outside the covering.



## INDEX

### A

A. B. C. process of sewage disposal, 108  
Access receiver, 167  
Accessibility of appliances, 230  
Acetate of lead, 376  
Acid gas, carbonic, 30, 37  
—, hydrochloric, 469  
—, muriatic, 469  
Act, Public Health, 1875, 103  
—, River Pollution, 105  
Actual discharge, 63  
— velocity, 63  
Adamant lavatory, 336  
— water-closets, 244  
Adams' patent bacteria bed, 122  
— patent flushing syphons, 125  
— patent sewage lift, 123  
Adams & Co.'s titanite lavatory, 332  
— water-closets, 268  
Adhesion, 40  
Adjustable interceptors, 176  
— traps, 176  
Adjutages, 57, 66  
Aerated filters, 387  
Aerometry, 43, 77  
After-flush waste-preventers, 341  
Air, 78  
— inlets, 184  
Air-tight cover, 172  
Alloyed lead, 379  
Alloys, 456, 465  
—, melting-point of, 99  
Alumina process, sulphate of, 110  
Ancient plumbing ordinances, 4  
Anderson's sewage process, 106, 110  
Angus Smith's solution, 162, 204  
Anti D-traps, 219  
Antimony, 449  
Antiquity of plumbing, 2  
Antiseptic lavatory, 323  
— system, 121  
Appliances, sanitary, 230  
Applied Bacteriology, 120  
Appold's overflow pipe, 76

Apprenticeship, 10  
Area of circles, 137, 482  
— of ellipse, 483  
— of triangle, 482  
Areas of drain-pipes, 137  
Asphyxia, 102  
Asphyxiator, 194  
Atmospheric pressure, 77-80  
Atoms of matter, 26  
Attraction, capillary, 41  
—, cohesion, 39  
—, gravitation, 31  
Autogenous soldering, 223  
Automatic flushing tanks, 350  
Avoirdupois weight table, 494

### B

Bailey Denton's tables, 140, 389  
Baldwin Latham's tables, 140  
Ball taps, 355-358  
— traps, 221  
Barometer, 80  
Barometric pressure, 80  
Basins, douche, 326  
—, lavatory, 321-339  
—, tip-up, 339  
—, waste-receiver, 178, 179  
Bathroom hot-water coil, 307  
Baths, 303-319  
—, needle-douche, 315-319  
—, reclining, 303-317  
—, sitz, 314  
—, white earthenware, 304  
Bed-pan sink, 294  
— washer, 296  
Bending copper pipes, 221  
— lead pipes, 214  
Bends, 215, 219  
—, friction due to, 74  
Betterment water-closet, 257  
Biological process, 119  
Block joints, 213  
Blow-pipe joints, 210  
Boiler, 418

Boiler, cause of noises, 418  
 — explosions, 428  
 Boiling-points, 98, 489  
 Bower-Barff process, 162, 415  
 Boyle's law, 81  
 Branch lead-work, 215  
 Burst pipes, frost, 29  
 Butler's pantry troughs, 298

C

Cabriole lavatory, Adams', 331  
 Cameron's process, 379  
 Capillary attraction, 41  
 Carbolic acid—disinfectant, 365  
 Cast-iron drains, 131, 159  
 — soil-pipes, 204  
 Cast-lead traps and bends, 219, 220  
 Cast sheet lead, 457  
 Cause of flow of water, 55  
 — of fracture, 374  
 — of frost-burst in pipes, 28, 29  
 — of hot-water circulation, 86, 423.  
 — of noise in pipes, 418  
 Cement for drain joints, 146  
 Centigrade thermometer, 97  
 Cesspool, 104  
 — air, 102  
 — ventilation, 105  
 Chambers, manhole, 150, 167-171  
 —, intercepting, 150, 167  
 Channel bends, 168-170  
 Chemical properties of lead, 454  
 Chloralum—disinfectant, 365  
 Chloride of lime sewage process, 107  
 — of iron sewage process, 107  
 Christisson's process, 380  
 Circulation of hot water, 86, 423  
 Circumference tables, 137  
 Cistern, filling and emptying, 67  
 — lining, 222  
 — overflow, 54  
 —, position, 414  
 —, water waste-preventing, 342  
 Cisterns, 414  
 City and Guilds of London Institute, 1  
 Classes, technical, 12  
 Closets, water, 231-272  
 Coating iron pipes, 161  
 Co-efficients for orifices, 68  
 —, table of, 135  
 Cohesion, attraction of, 39  
 Coil, heating, 307  
 Combination closet, 245  
 Combined sewerage, 126  
 Commission, Rivers Pollution, 108  
 Company, Plumbers', 1, 3, 6  
 Composition of air, 78

Composition of lead pipes, 380, 492  
 — of water, 78  
 Conduction of heat, 93  
 — table, 94, 494  
 Condy's fluid, 376  
 Congress, Plumbers', 6  
 —, Vienna, 117  
 Constant water supply, 413  
 Contents of cisterns, 68, 69  
 — of cone, 483  
 — of cylinders, 68, 483, 484  
 — of water-pipes, 70, 484  
 Contracta, vena, 58  
 Contraction and expansion, 85  
 Convection of heat, 92  
 Copper, 463  
 —, action on water, 354, 378  
 — baths, 303  
 — or brass ferrules, 206  
 — pipes, 221  
 Copperas, 464  
 Copper-bit joints, 210  
 Corbel lavatory basins, 335  
 — water-closets, 264  
 Corrosion of lead, 379  
 Cowl-testing, 187  
 Cows, 187-189  
 —, archimedean, 187  
 —, revolving, 187  
 —, trumpet-shaped, 189  
 Cubic measure, 495  
 Cylinder, contents, 68  
 Cylinders, hot-water, 420

## D

Danger from sewer air, 102  
 Dangerous houses, 2  
 Decimal gradients, 138  
 Decimals of inches table, 137  
 Deep-well pumps, 393  
 Definition of drain and sewer, 103  
 — of good trap, 217  
 Deluge water-closet, 243  
 Deposit of lime, 372  
 Depth, hydraulic mean, 134  
 Discharge from drains, 140, 487  
 — from pipes, 73, 487  
 — of water, 67, 68, 487  
 — tables, 140, 487  
 Disconnection, 163  
 — traps, 172  
 — receivers, 178  
 Disinfectants, 365  
 Disposal of sewage, 101  
 Double-action pump tables, 388  
 Douche baths, 315-319  
 — water-closets, 246



Drain access, 167, 175  
 — cleansing machine, 195  
 — connections, 155-171  
 — disconnection, 167  
 —, forces at work in, 2  
 —, foundation, 144  
 — gradients, 132, 141  
 —, hydraulic, mean depth of, 133-138  
 — interception, 148-177  
 — jointing, 145-163  
 — materials, 131  
 — pipes, quality of, 154-156  
 — and sewer, 103  
 — stopper, 191  
 — subsoil, 158  
 — test by smoke 193  
 — — water, 191  
 — testing, 190  
 — under scullery, 147, 151  
 — ventilation, 184  
 Drainage of houses, 126  
 Drains, cast iron, 131, 159  
 —, contents of, 484  
 —, discharge from, 133, 487  
 —, sectional area of, 137  
 —, velocity in, 133, 488  
 Drawing for plumbers, 16  
 Drawn-lead traps and bends, 219  
 — soil-pipes, 203  
 D-traps, 217  
 Dubois drawn-lead traps, 219  
 Duties of plumbers, 7

## E

Ebullition and pressure, 99  
 Education of plumbers, 9  
 —, technical, 11  
 Edward III., ordinances of, 4  
 Effects of frost, 28, 29  
 — of gravity, 33  
 — of heat, 28, 85  
 — of sewer air, 103  
 Efflux of water, 52  
 Elements, 26  
 Enamelled fire-clay baths, 304  
 — — troughs, 300  
 — — sinks, 285-300  
 Energy and matter, 23  
 — of motion, 24  
 — of position, 24  
 Equal transmission of pressure, 45  
 Exeter sewage system, 121  
 Expansion and contraction, 85  
 — of water, 54, 489  
 Extractor tops, 187-190  
 Eytelwein's formula, 71, 487

## F

Fahrenheit's thermometer, 97  
 Fastenings, patent pipe, 205  
 Ferrozone process, 107, 111  
 Fever, typhoid, 103  
 Filters, aerated, 387  
 Filtration, intermittent, 114  
 — of sewage, 113  
 — of water, 386  
 Fire-clay baths, 304  
 — sinks, 285-300  
 — troughs, 300  
 Flap-valves, copper, 264  
 —, mica, 186  
 Flow of water in pipes, 70, 487  
 Flushing rims, 241-261  
 — tanks, 349  
 Fluxes, 100  
 Forces in drains, 128  
 Formula, Eytelwein's, 71, 487  
 —, Hawksley's, 72  
 —, Manning's, 72  
 —, Neville's, 72  
 —, Torricelli's, 60  
 — for velocity, 133  
 Foundation for drains, 44  
 —, damp, 159  
 Fracture in boilers, 343  
 Frankland's experiments, 102  
 Freezing-point table, 99, 490  
 Fresh-air inlets, 172-174  
 Friction, 56  
 — due to bends, 74  
 — on water flowing, 70  
 Frost effects, 29, 30  
 — explosions, 427  
 Fusing-point table, 99, 490, 491

## G

Galena, 448  
 Galileo, 79  
 Galvanised iron, 381  
 Gas pressure in drains, 129  
 —, sewer, 102  
 Gases, pressure of, 27  
 Gauge, rain, 369  
 Gauging water, 401  
 Gradients, decimal, 138  
 —, hydraulic mean, 70  
 — of drains, 132, 141, 488  
 — of sewers, 127, 487, 488  
 Gravitation, attraction of, 31  
 Gravity, effects of, 33  
 —, measure of, 35  
 —, specific, 36  
 —, table of specific, 38  
 Grease-traps, 180-183  
 Gully-traps, 180

## H

- Hammer, water, 35  
 Hard and soft solders, 465  
   — — waters, 372  
 Hardness of water, permanent, 373  
   — —, temporary, 373  
 Hawksley's formula, 72  
 Head by friction, loss of, 74  
   — of water, 69, 483, 486  
 Heat, 83  
   — absorption table, 90  
   — conduction, 94, 494  
   — convection, 92  
   —, effects of, 83  
   —, effects on lead of, 85  
   —, latent, 94  
   —, measurement, 96  
   —, mechanical equivalent of, 84  
   —, radiation of, 90  
   —, reflection of, 92  
   —, specific, 86  
   —, standard unit of, 84  
   —, table of specific, 87  
   —, transmission of, 88  
 Heating bathroom, 306  
   — coil, 307  
 Helmet traps, 218  
 High-fall turbine, 411  
 Horse-power, 388  
 Horse-pumps, 399  
 Hospital appliances, 246, 294-297  
   — bed-pan sinks, 294-297  
   — lavatory, 323  
   — slop sinks, 291-301  
 Hot-air engine, 401  
 Hot-water circulation, 86  
 House drainage, 126  
 Hydraulic cement, 495  
   — mean depth, 134-137  
   — — tables, 137  
   — — gradient, 50  
   — ram, 401-408  
   — —, rules, 404  
   — rules, 62-65  
 Hydraulics, 43  
 Hydrochloric acid—disinfectant, 365  
 Hydrogen, 224  
 Hydrostatic paradox, 47  
 Hydrostatics, 43, 45  
 Hygienic Congress, Vienna, 117

## I

- Impenetrability of matter, 26  
 Inclination of drains, 132  
   — of sewers, 127  
 Independent baths, 304-319  
   — lavatory basins, 321-339

- Independent water-closets, 238-270  
 Inertia, 26, 29  
 Inlets, air, 184, 187  
 Intercepting chambers, 150-167  
 Interception, 148-167  
 Interceptor traps, 166-177  
 Intermittent filtration, sewage, 113  
   — water supply, 381  
 International process, sewage, 107, 111  
   — water-closets, 232  
 Iron drain, coating, 152  
   — —, weight of, 153  
   — drains, 125, 150-157  
   — process, chloride of, 107  
   — —, sulphate of, 112, 117  
   — soil-pipe, 203  
   — — joints, 206

## J

- Jointing drains, 145-162  
   — lead and iron pipes, 206  
   — pipes, 206-214  
 Joints, block, 213  
   —, blowpipe, 210  
   —, copper-bit, 210  
   —, moulded, 214  
   —, overcast, 212  
   —, rust, 496  
   —, slip, 208  
   —, taft, 210  
   —, underhand, 212  
   —, upright, 212  
   —, wiped, 211  
 Jones' drain stoppers, 191  
 Joule's mechanical equivalent of heat, 84

## K

- Kelvin taps, 360-365

## L

- Latent heat, 94  
 Latrine, Adams & Co., 269  
 Lavatories, 321-339  
   —, public, 333  
 Lavatory waste-receivers, 178  
 Laws of gravitation, 31  
   — of motion, 29  
 Lead, 448  
   — acetate, 376  
   — alloys, 379  
   — bends, 214  
   — branch-work, 215  
   — burning, 223  
   —, chemical properties of, 454  
   —, composition, pipes, 380, 493  
   — corrosion, 380  
   — jointing, 206-214

Lead, physical properties of, 463  
 — poisoning, 375-380  
 — protection, 380  
 — soil-pipes, 203, 206  
 — traps, 217-221  
 — waste-pipes, 213  
 — pipe bending, 214  
 Lime, action on lead, 379  
 — in water, 374  
 — process, 107  
 Limit of suction-pump power, 389  
 Lineal measure, 495  
 Litre, 485, 495

## M

Manhole chambers, 150, 167-171  
 Manning's formula, 72  
 Materials for drains, 131  
 Matter and energy, 23  
 —, properties of, 26, 30  
 Mean depth, hydraulic, 134-137  
 — gradients, hydraulic, 70  
 Measure of gravity, 35  
 Measurement of heat, 96  
 Melting-point tables, 99  
 Metre, 495  
 Mica flap-valves, 186  
 Microbes in sewage, 119  
 Mid-feather traps, 220  
 Motion, energy of, 24  
 —, laws of, 29

## N

Needle-douche baths, 315-319.  
 Neville's formula, 72  
 Non-conducting covering, 496  
 Non-conductors, 494

## O

Objects of sanitary plumbing, 366  
 Ordinances of Edward III., 4  
 Orifices and adjutages, 57, 59, 66  
 Orifices, co-efficient, 68  
 Overcast joints, 212  
 Overflow, Appold's, 75  
 — of cisterns, 54  
 — stand-pipes, 75

## P

Pantry troughs, 298-301  
 Paradox, hydraulic, 47  
 Pascal, 45  
 Peppermint test, 194  
 Permanent hardness of water, 373  
 Permanganate of potash, 376

Physical properties of lead, 453  
 Pipe-bending, 214  
 Pipes, contents, 70  
 —, copper, 221  
 —, flow of water in, 70  
 —, iron, 159  
 —, lead, 203  
 —, soil, 203-214  
 —, waste, 213  
 Plumber's solder, 465  
 — stove, 13  
 Plumbers, drawing for, 16  
 —, science for, 22  
 Plumbers' Company, 1, 3, 6  
 — Congress, 6  
 — duties, 7  
 — education, 9  
 — prejudices, 8  
 Plumbism, 375, 379  
 Pneumatics, 43, 77  
 Portland cement, 496  
 Position, energy of, 24  
 Pouillet's tables, 491  
 Practical training, 15  
 Pressure, atmospheric, 77, 80  
 —, equal transmission of, 45  
 — of gases, 27  
 — of water, 47, 48, 69  
 — on water-traps, 82, 129  
 Preventers, water waste, 340, 349  
 Process, Angus Smith's, 162  
 —, Bower-Barff, 162, 415  
 Properties of lead, 453, 454  
 —, of matter, 25-43  
 Proportion of dangerous houses, 2  
 Protection of lead, 379, 380  
 Public lavatories, 333  
 Pump, force, 394  
 —, horse, 399  
 —, piston, 69  
 —, suction, 391  
 —, wheel, 397  
 Pumping power, 31  
 — table, 388, 389, 489  
 Pumps, 388

## Q

Quality of drain-pipes, 154-156  
 — of lead, 448  
 — of sanitary appliances, 230  
 — of trap, 217  
 — of water, 375  
 Quantity of water discharged, 140

## R

Radiation of heat, 88, 90  
 Rainfall, 368  
 Rain-gauge, 369

- Rain water, 369  
 Ram, check-valve, 407  
 —, formula for hydraulic, 404  
 —, hydraulic, 404  
 —, results from hydraulic, 404  
 —, starting hydraulic, 406  
 Rasp, 473  
 Receiver, access, 178  
 —, bath and basin waste, 178  
 —, disconnecting, 179  
 —, scullery-sink waste, 178  
 Reclining baths, 303-317  
 Reflection of heat, 92  
 Relative thickness and weights of lead, 453  
 Resin, 470  
 Resistance of water, 69  
 Responsibility of plumbers, 130  
 Revolving cowls, 187  
 River Pollution Act, 1876, 105, 117  
 — Commission, 108, 116, 119  
 Roman cement, 496  
 Roof lead, action of heat on, 85  
 Rules for discharge in pipes, 140  
 — for hydraulic rams, 404  
 — for pumps, 388  
 — for velocity in pipes, 139  
 — for water pressure, 47  
 —, hydraulic, 62-5  
 Rust cement, 496
- S
- Safety disconnecting receivers, 179  
 — valves, 434-440  
 Sal ammoniac, 470  
 Sanitary appliances, 230  
 — plumbing, 202, 366  
 School lavatory, 337  
 Science for plumbers, 22  
 Screw-wrench, 474  
 Scullery, drains under, 150, 151  
 — grease-traps, 180-183  
 Secondary circulation, 423  
 Sectional area of drains, 137  
 Separate sewerage system, 126  
 Septic tank system, 121  
 Sewage disposal, 101-125  
 — biological treatment, 119  
 — outfalls, 104  
 — precipitation, 106  
 — septic tank, 121  
 Sewer air, 102  
 — and drain, definition of, 103  
 — gradients, 127, 487, 488  
 — inclination of, 127  
 — ventilation, 127  
 Shallow-well pumps, 392  
 Shave-hooks, 472  
 Sheet lead, 458  
 Shifting valve, 408  
 Shower-baths, 316-319  
 Silver cupellation, 453  
 Sin of cheapness, 200  
 Sitz-baths, 314  
 Size of drains, 141  
 — of interceptor traps, 149  
 Slip joints, 208  
 Slop-sinks, 282-297  
 Slop-troughs, 289-293  
 Smith's process, Angus, 162, 204  
 Smoke test, 193, 194  
 Smudge, plumber's, 468  
 Soft water, 371  
 Softening water, 373  
 Soil-pipe joints, 208-214  
 — ventilation, 202-204  
 Soil-pipes, 203-214  
 —, cast-iron, 204  
 —, lead, 203-214  
 Solder, fine, 466  
 —, hard, 465  
 —, ladle, 472  
 —, plumber's, 465  
 — pot, 472  
 — purification, 466  
 —, sealed, 465  
 —, soft, 465  
 Soldering, autogenous, 223  
 — irons, 471  
 Specific gravity, 36, 38  
 — heat, 86, 87  
 Speculum metal, 465  
 Spelter, 462  
 Splash-stick, 472  
 Spring water, 372  
 Standard for materials, 6  
 — for plumbers, 6  
 — heat unit, 84  
 — measures, 64  
 — units, 47, 84  
 Steam pressure, 490  
 Steam-pipe coating, 496  
 Stoppage of drain, 196  
 Stopper, drain, 191, 192  
 Stop-valves, 365, 447  
 Storage of water, 413  
 Stove, plumber's, 13  
 Straight-edge, 473  
 Subsoil drainage, 158  
 — drains, 158  
 Suction pump, 391  
 Sulphate of iron, 107, 112  
 Supply, constant water, 413  
 —, hot-water, 417  
 —, intermittent water, 413

Supply, water, 367  
 Syphon flushing tanks, 350  
 — waste-preventers, 340-349  
 Syphonage of traps, 203  
 Syphonic action, 82

T

Table of absorption of heat, 90  
 — of alloys, 491  
 — of boiling-points, 98, 489  
 — of co-efficients, 135  
 — of decimal gradients, 138  
 — of decimals of inches, 137  
 — of discharge, 487  
 — of double-action pumps, 388, 489  
 — of fusing points, 98, 490-491  
 — of hydraulic mean depth, 134-137  
 — of internal circumferences, 137  
 — of melting-points, 99, 490-491  
 —, Peclet's, 90  
 — of pumping results, 388, 489  
 — of radiation of heat, 90  
 — of reflection of heat, 92  
 — of sectional areas, 137  
 — of specific gravity, 38  
 — — heat, 88  
 — of steam pressure, 490  
 — of velocity and discharge, 139-141,  
 487, 488

Tables, miscellaneous, 482-495  
 Taft joint, 210  
 Tampin, 473  
 Tank, storeroom, 414  
 Tanks, flushing, 349  
 —, water, 413  
 Technical education, 11, 12  
 Temporary hardness of water, 373  
 Test, peppermint, 194  
 —, smoke, 193  
 —, sulphur acid, 195  
 Testing cowl, 187  
 — drains, 190  
 Tests of water, 376  
 Theocamf—disinfectant, 365  
 Theoretical discharge, 62  
 — velocity, 62  
 Thermometer, centigrade, 97  
 —, Fahrenheit, 97  
 —, Réaumur, 97  
 — rules, 97, 98  
 Tin, 460  
 —, properties of, 461  
 Tin-lined lead pipes, 459  
 Tip-up basins, 340  
 Titanite ware, Adams', 268, 275, 332  
 Tongs, gun-barrel, 476  
 Tools, caulking, 474

Tools, plumbers', 471-477  
 Tops, extractor, 188  
 Torricelli, 79  
 Touch, 470  
 Training, practical, 15  
 Transmission of heat, 88  
 — of water pressure, 45  
 Trapless water-closets, 253  
 Traps, adjustable, 176  
 —, anti D, 219  
 —, ball, 221  
 —, bell, 221  
 —, D, 217  
 —, disconnecting, 172  
 —, Dubois, 219  
 —, grease, 180-183  
 —, gully, 180  
 —, helmet, 218  
 —, lead, 218  
 —, mid-feather, 220  
 —, pressure on, 82, 129  
 —, sanitary, 217  
 —, soil-pipe, 179  
 —, syphonage in, 203  
 Troughs, pantry, 298-301  
 —, scullery, 295  
 —, slop, 289-293  
 —, washing laundry, 302  
 Tumbler water waste-preventers, 342  
 Turbines, 409  
 —, high-fall, 412  
 —, low-fall, 411  
 —, vortex, 412  
 Turnerscrew, 474  
 Twin-basin water-closets, 254  
 Typhoid fever, 103

## U

Unit of area, 47  
 — of heat, 84  
 — of work, 84  
 Underhand joints, 212  
 Upright joints, 212  
 Urinals, 273-282  
 Uses of lead, 456

## V

Valves, check, 407  
 —, flap, 263, 264  
 —, mica flap, 186  
 — on boilers, safety, 427  
 Valves on circulating pipes, 447  
 —, shifting, 408  
 Velocity, actual, 63, 488  
 — due to gravitation, 33  
 — formula, 133, 134  
 — in drains, 133, 488

Velocity, maximum point of, 133  
 — of water flow, 57, 73  
 — tables, 139, 488  
 —, theoretical, 62  
 Vena contracta, 58  
 Ventilation of cesspools, 105  
 — of house drains, 184  
 — of manhole chambers, 184  
 — of sewers, 127  
 — of soil-pipes, 184, 216  
 — principles of, 184-188  
 Vent-pipes, 184, 216  
 Verdigris, 464  
 Vienna Hygienic Congress, 117  
 Vis inertia, 26, 29  
 Vitriol, blue, 464  
 —, green, 464  
 Vortex turbine, 412

## W

Washhand basins, 321-339  
 Waste-pipe receivers, 178  
 Water, 367, 483-486  
 — efflux, 53  
 — expansion, 54, 489  
 — filtration, 386  
 — flow, cause of, 55  
 — —, formula, 71, 72  
 —, hardness in, 373  
 — power, 400  
 — pressure, 47, 48, 486  
 — softening, 374  
 — storage, 413  
 — supply, 367  
 — tanks, 413, 491, 492  
 — tests, 376  
 — traps, pressure on, 82, 129

Water waste-preventer cisterns, 342  
 — — — valves, 347  
 Water-closet cisterns, 342  
 Water-closets, Dececco, 257  
 —, Dill, 234  
 —, douche, 247  
 —, independent, 243, 245  
 —, pan, 231  
 —, syphonic, 256  
 —, trapless, 252  
 —, twin-basin, 254  
 —, valve, 259-263  
 —, wash-down, 240-252  
 —, wash-out, 235-238  
 —, Adams', 268  
 Weight of brass, 485, 493  
 — of cast iron, 484, 494  
 — of copper, 485, 493  
 — of iron, 484, 494  
 — — — drains, 162, 493  
 — of lead, 458, 485, 492  
 — of water, 484  
 — of wrought iron, 484, 494  
 Weir, water flow over, 401  
 Wells, pollution of, 105, 106  
 — under houses, 158  
 Wheel-pumps, 397  
 Wind engine, 399  
 Wiped joints, 211  
 Wire-gauge, 459, 493

## Z

Zinc, 461  
 —, action on water, 381-385  
 —, chloride of, 469  
 —, manufacture, 461  
 —, properties of, 462



PLYMOUTH  
WILLIAM BRENDON AND SON  
PRINTERS

3









TD905

M2

1903

130065

