



UNIVERSITY OF MASSACHUSETTS
AT AMHERST



UNIVERSITY LIBRARY
Special Collections & Rare Books

Spec.
Coll.
SF
305
S8
D7
1891





"Five Seamen"

DRIVING AS I FOUND IT.

WHAT
TO
DRIVE

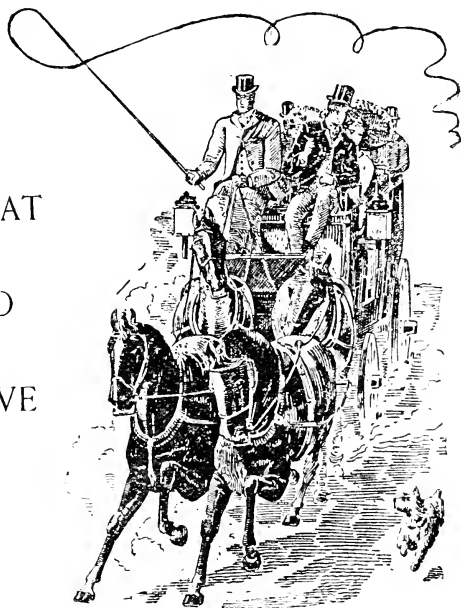

HOW
TO
DRIVE

BY

FRANK SWALES.

ILLUSTRATED BY WALTER PETTEE.

(COPYRIGHTED.)

ECLIPSE PUBLISHING CO.,
54 WEST TWENTY-THIRD STREET, NEW YORK.

1891.

LINOTYPE PRINT.
BY
RAPID PRINTING COMPANY,
220-222 WILLIAM ST.,
NEW YORK.



Chauncey A. Hays



To Colonel DeLancey Kane.

In recognition of his rare, good qualities, as a gentleman, whip and sportsman, the appreciation of which can find no more ardent admirer than his humble servant, who with his permission respectfully dedicates this work to him.

FRANK SWALES.





CONTENTS.

	PAGE.
Observations	17
Gentlemen Dealers	30
Tattersalls	34
Horse Dealers	46
Buying Horses	52
High Steppers	60
Cappers	65
Feeding	69
Shoeing	73
The Auction Marts	76
Horse Shows	81
What to Drive	85
How to Drive One Horse or a Pair.....	94
The Whip	104
The Tandem	109
How to Drive Tandem and Four.....	119
Four in Hand	132
Six in Hand.....	163
The Old Times (Song).....	172
Coaching in America.....	175

LIST OF ILLUSTRATIONS.

	PAGE.
Colonel DeLancey Kane.....	Frontispiece
Sale Day at Tattersalls, N. Y.....	35
Interior of Tattersalls, N. Y.....	41
Exterior of Tattersalls, N. Y.....	53
A Good Sort.....	61
Inclined to be Tricky.....	79
A Roadster	87
False Breeching	91
Tandem, Mr. Benton Mansfield.....	107
No Thoroughfare	112
Showing Off	113
Sleigh Tandem	117
A Professional	133
Above His Business	141
Break Blocks	158
Outing Break	161
Chain Trace	162
Coach "Mohican "	165
Coach "Tally Ho "	173

TWENTY-ONE DRIVING LESSONS.

FIG.	ONE HORSE OR PAIR.	PAGE.
1.	Starting Off	94
2.	Pulling Up	96
3.	Shortening Reins	97
4.	Turn to Near Side.....	98
5.	Turn to Off Side.....	99
TANDEM AND FOUR.		
6.	Taking Reins in Hand.....	119
7.	Reins in Left Hand.....	120
8.	Change to Right, Before Getting on Box Seat..	120
9.	Ready to Start.....	121
10.	Old Style Way to Start.....	122
11.	Turn to Left.....	123
12.	Near Lead Rein Looped.....	124
13.	Turn to Right—Loop Made.....	125
14.	Near Side.....	126
15.	Off Side.....	126
16.	Steadying Leaders.....	127
17.	Shortening Lead Reins.....	128
18.	“ “ “	129
19.	Shortening Wheel Reins.....	130
20.	Throw Out Off Reins.....	131
21.	Six in Hand.....	169

INTRODUCTION.

Whether a regular preface is of any advantage to a book I am not sufficiently versed in literary matters to determine; still I consider that a proper feeling of respect for the driving public calls for something in the shape of an introduction.

I trust that the public will look over whatever errors may have slipped into this book, and accept it as a general treatise on driving, with the observation and opinions of a practical man, committed to paper as the ideas suggested themselves, which, if they are taken together, may be thought in some parts useful, in others occasionally amusing, I shall have realized all I could anticipate or wish for. The hints, observations and illustrations contained in this book are not merely those of one who learned for pleasure, but were gathered during many years' experience as professional coachman, both in England and in America.

DRIVING AS I FOUND IT.

OBSERVATIONS.

On nearly every art or science practised by man there has been instructions, treatises, opinions, criticisms, and I know not what, repeatedly published. They rank from the highly intellectual study of astronomy to the more manual art of making a horseshoe. Nothing scarcely has been thought too insignificant to fix the attention and call forth the written opinions of those conversant with their subject. Horsemanship produced writers of a very early date, varying their instructions and terms used according to the age in which they lived and wrote. But I am not aware that any really good instructions in the art of driving have yet appeared in print. Why driving should have been hitherto considered less worthy of attention as a subject to be written about than horsemanship I cannot explain. That it should be done well, if done at all, I consider most important. If a man rides he rides alone, and has most unquestionably a right to break his own neck if he pleases, but if he is driving others, he certainly

has no right to break their necks. It is singular enough that, though hundreds of men who ride on horseback, willingly allow that they are very indifferent horsemen, but you will rarely find a man who drives even a buggy who does not conceive he does it as well as it can be done, or who for one moment thinks he is in danger through his ignorance. No doubt there is no great exertion or art required to sit in a buggy, hold the reins and guide a steady horse the way you wish him to go, but even in this humble attempt at coachmanship the way it is many times done would, to a practised eye, at once show that, while one man is capable of greater things, another was not capable of doing well the little he did attempt. It is true a man may drive one horse well, but this does not prove him to be a good pair-horse coachman. In the same way many may also drive a pair well but be quite astray with four. But whether with one horse, a pair, a unicorn, or regular team before him, the coachman is to be detected at once. His manner of taking up his reins and seating himself will be quite sufficient proof. Coolness, light hands and good temper are the essential qualities requisite to make a good coachman. These are much more necessary in a coachman than in a horseman if for nothing but for the sake of others. An irritated horse bolts off with his rider or throws him, or both,

he alone then pays the penalty of his fault, but an irritated horse in harness, particularly in light private carriages, is dangerous to a degree. We may and can manage him as wheeler to a coach, the weight and his companion holding him in check, but in a light carriage let me tell young coachmen who may think they are in little danger, that no man living can hold two horses determined to run away, and as to four all in the same mind they are no more to be held than a locomotive engine. For this reason their steam should never be got up too high.

Having got so far I must now do what I ought to have done at the commencement,—show my motive for commencing at all. It was neither more nor less than that I considered a regular treatise on driving, in the general sense of the word, would be a work of great utility, and all I intend, or hope to do, is to show that driving is not quite comprehended by sitting behind a horse or given number of horses, with the reins in the driver's hand, trusting to Providence and good luck for getting along in safety.

“A little knowledge is a dangerous thing,” I really flatter myself that I possess comparatively a good deal in these matters, yet this teaches me that I do not know quite half enough, and also that many who profess a great deal really know nothing at all.

If a man from inclination or circumstances is destined to drive only one description of vehicle and one description of horse it would be sufficient for his purpose that he drives that vehicle well and safely. The private servant who drives a brougham or a landau or any description of one horse or pair-horse carriage, may do very well for this, and doubtless flatters himself he could do very well for any other description of coachmanship. He would, however, find himself, or at all events, others would find him, woefully deficient when put to the test. The different description of knowledge and practice required in driving different descriptions of carriages, different descriptions of horses, and those in different descriptions of situations, is much more varied than people are apt to imagine. The finished coachman can drive anything, and drive it well, but he will not, nor cannot drive anything equally well. There can be no doubt but the stage coachman requires, and fortunately acquires, generally speaking, more diversified knowledge in coachmanship than any other votary of the whip, particularly when driving sixty or seventy miles across a country. Here he will have perhaps nine or ten teams to drive, and to learn how to manage the tempers of from forty to fifty different horses, independent of the chances of these horses becoming lame or ill from accidents and various other circumstances which

may from time to time occur. He will have to know how to get over all sorts of ground with the greatest advantage as to time, the ease of his horses, and the safety of his passengers, clearly showing that driving the same vehicle, I mean here a coach, in different situations and under different circumstances requires quite different management.

I wish my readers to understand that a man is not merely a coachman who, with everything put right for him, can contrive to turn corners without running against a post, or who can manage to wend his way along a road or moderately frequented street. He should understand his carriage, know its component parts, and their effects on its safety and running. If he does not know all these he might be driving with something about it loose, cracked, strained, broken or misplaced at the imminent risk of his own and his companions' lives. If not a judge of its running well or ill his horses will suffer. I need scarcely say it is also necessary that a good coachman should understand the full effect of every strap and buckle about his harness, for on properly harnessing and biting horses all their comfort and that of the driver depends. More accidents happen from the want of this than from any other cause, and horses are also often very much punished in their work from such neglect. A man ignorant of all

these matters does not know what is likely to lead to danger, and of course when once in it, he is as helpless as a child in adopting the best or perhaps the only means of getting out of it. The reader has doubtless often seen a coachman, before taking hold of the reins, go to all four of his horses' heads, lay hold of their bits and feel that each horse is properly bitted. Probably this to some has appeared a useless precaution. The coachman, however, knows better, for upon this a great part of his own and passengers' safety depends.

I may perhaps surprise many persons by stating that a horse improperly bitted will sometimes set him kicking. Some may say what on earth has his mouth to do with his heels? A great deal with some horses. They say "the devil is good-tempered when he is well pleased." So am I, and so is a horse, and while he is he goes pleasantly and quietly, but put a too severe bit in his mouth, and what is ten times worse, put the reins into rude hands, his mouth gets punished, which naturally irritates and puts him out of temper. If under these conditions any little thing occurs that at another time he would not have cared for, he sets to kicking at once.

The guarding against every probability of getting into difficulties or danger I consider the first duty of a coachman, knowing what is likely to lead to either is

an indispensable part of the qualification to become one, and when in difficulty a fine hand, strong nerve, a quick eye and presence of mind are all necessary to extricate him from it. Here the coachman shows himself, and here the dummy universally fails. The latter sees the effect plain enough, but knows nothing whatever of the causes, consequently he either sits still and does nothing, or if he does anything, in all probability does the very thing that increases both the difficulty and the danger.

In proof of what presence of mind and knowing what to do in an emergency will result in, I may mention a circumstance that occurred whilst driving, in fact, breaking a well bred pair of horses to harness. They had both become perfectly handy and were good-tempered, but from youth, high blood and high condition, ready to avail themselves of any excuse for a lark. I had driven them all about town perfectly well and all right, until coming down a hilly street up went the pole nearly to their ears, my toeboard nearly coming on the hind quarters. I now found something was all wrong, and guessed the cause. I immediately struck them both sharply with the whip. Off they went like two startled deers down the hill at about eighteen miles an hour, feather edging everything we passed, I expecting however, to give something an "insider," but escaped.

Ascending the opposite hill enabled me to pull up, when I found sure enough the pole pin had been left out.

Since 1876, when Colonel DeLancey Kane started the well-known coach "Tally Ho" from the Hotel Brunswick, New York, to New Rochelle, which first gave that impetus to coaching and mania for driving in this country, a great improvement in everything relative to horses, carriages and harness has been the result. The drive in Central Park can now compare favorably with the Row or the Bois de Boulogne, both for quantity and quality, except in one most particular point, and that the most essential point of all—the private coachman. When I speak of a coachman I mean one who has been brought up from boyhood in good stables, under good men, and knows his business thoroughly. The first coachman to a lady of fashion requires much more knowledge of his business than people generally suppose. Here every jolt must be broken, no swinging of his carriage over the crossings in the street, no sudden pulls up or hitting horses with such bad judgment as to cause a sudden backward jerk to the carriage. There should be no stopping at doors so as to leave it swaying backward and forward to the full extent of the check braces and the discomfiture of its delicate and fastidious inmates. The carriage must start, go on

its way and stop as smoothly as it went off. Merely passing safely between other vehicles would not be sufficient to satisfy a lady accustomed to be driven by such an artist as a first rate body coachman. To any amateur of driving it is really a treat to see such men handling their horses on such occasions as a Court day at Buckingham Palace. They may be seen threading the masses of a dense crowd, their carriages gliding about like so many gondolas on the Grand Canal at Venice. No fuss, no pulling and hauling; a turn of the wrist is sufficient for horses accustomed to be driven by such coachmen. All seems easy to the bystanders, no difficulty appears, but this apparent ease shows the masterly hand that is at work. There is a kind of freemasonry among such men that enables them to detect the perfect coachman at a glance. A cast of the eye at the hands of each other on meeting is sufficient to show to each what the other intends doing. They know they will each do what they intend, though only an inch of spare room is between them. With confidence in their mutual skill they fearlessly pursue their course with as much precision and certainty as if the wheels of their carriages were confined in the track of a railroad. Mishaps or even mistakes on such occasions hardly ever occur, and for this reason they are all perfect artists. But go to the theatres, the scene is widely

different. Here is to be heard swearing, whipping, smashing of panels, backing of horses, vociferations of coachmen, cabmen and policemen, the whole place a perfect pandemonium. This contrast arises from the fact that in the latter case there are a number of men employed to drive carriages who have little claim to the name of coachman. These clumsy workmen often fall to the lot of ladies, and nearly always to merchants and business gentlemen who keep carriages, the owners not being competent judges of driving, take a coachman from the recommendation of others who probably know as little of the necessary elements of a good coachman as themselves. Here let me strongly recommend ladies never to take a coachman on mere recommendation, unless they know the person who gives the recommendation to be a perfect judge of the requisite qualities of one. If they consider a man to be a promising candidate, before finally engaging him let them get some one of their acquaintances who thoroughly understands such matters to sit by his side on the box for half an hour. He will then either be at once disproved of, or they will be certain of having a servant who understands his business. Ten dollars a month more in wages will be amply made up by avoiding coachmakers' bills for repairs or those of veterinary surgeons for accidents to horses. They

will also have their carriage horses and harness neatly turned out, 'be properly and safely driven by a man who looks like a coachman, instead of getting one who does not know how to do either, and who will probably be asked by some knowing fellow, "Hello, there, who feeds the pigs when you are out?" Or, "I say neighbor, how much extra does your boss give you for milking?" An untaught, stupid house servant plagues and mortifies one by his awkwardness but a coachman with similar characteristics, should never be trusted at large without a string and collar about his neck to keep him off coachboxes.

I have in the foregoing page only paid a just tribute to the merits of the coachman of ladies or men of large fortunes, but I must at the same time remark that I never yet saw a gentleman's coachman who could drive four horses that he had been unaccustomed to drive. They make the worst stage coachmen of any men who have been in the habit of driving at all. They have been so used to horses all matched in step and temper that they are absolutely lost with any other. Coachmanship is therefore to be shown in various ways as well as the want of it, and is exhibited under as various circumstances. Take, for instance, those well-known knights of the whip, Fownes, the late Selby, Cracknel, Huble and others too numerous

to mention, there were none of them to my knowledge at any time during their career, private coachmen, but they served their apprenticeship and learnt the art which brought them prominently before the public as stage coachmen, or more commonly speaking, omnibus drivers.

The Petersburg driver with his bells and sleigh is equally a coachman in his way. The Canadian, recklessly as it appears to us, crosses his corduroy roads, drives over half-formed bridges or down declivities with his pole three feet above his horses heads in a way none here could do it. The "conducteur" of a Paris diligence brings his five horses with his "town" behind them in a trot into the inn yard at Calais. All three are coachmen in their way and yet none of them could perform the parts of the other. I have no doubt but to perform each of their duties well requires about an equal share of intellect and practice.

It is quite evident by what I have already said, that driving, to do it well, should be learned scientifically, and that there is much more danger in trusting ourselves in the hands of persons ignorant of these matters than is generally supposed.

The starting of the Coaching Club in New York has been the means of bringing out some very excellent gentlemen coachmen which undoubtedly renders those

who participate in this kind of sport good judges of the qualifications, powers and merits of the horse for such purposes, and by constant buying and selling such horses, it makes them judges of their relative value. Long may such men live to enjoy the amusement which their ample fortunes render possible. There are without doubt pursuits of a higher order, pursuits that produce more beneficial results to mankind in general, but every man of fortune has an undoubted right to spend that fortune in such pursuits as he conceives affords him the most gratification, and provided that the pursuit be a harmless one, no one has a right to interfere with it. The pursuits of the sportsman while carried on by the gentleman, are generally not only harmless, but beneficial to others, they give employment to many and occasion a great deal of money to be expended.



GENTLEMEN DEALERS.

There is one point I must respectfully impress upon my readers, i. e., being a first rate judge of a horse will not enable him to be a horse dealer. A gentleman may know perfectly well the relative value of horses and may easily ascertain the value of any other article of merchandise so far as buying and selling goes. He may even learn where in some measure how to buy and sell a horse to the best advantage, but this does not qualify him for a horse dealer. I am sure that no gentleman ever has or ever will succeed as a regular horse dealer. That there are however many who in a private way do to a very considerable extent deal in horses, is a notorious fact and a fact very much to be regretted. It is a subject of still further regret that among them are found those who in every other transaction are men of unblemished honor and integrity. If these gentlemen conceive that they carry on this underhand kind of private trade without it calling forth very severe animadversion from those who abstain from it they very much deceive themselves, and they labor under the influence of a still further error if they suppose

that they can continue this practice, without losing very considerably in point of character and prestige in the estimation of their friends and acquaintances. Placing them in comparison with the regular horse-dealer, I have no hesitation in saying that so far as this pursuit is concerned, I consider the latter the most respectable man. He sells you a horse openly as a dealer, as a man who disposes of him entirely for profit; you probably place no reliance upon his word, or confidence in his honor, he does not ask you to do so, nor is he offended if you do not. You purchase of him in most cases under a written warranty. If the horse does not answer the description given of him the law is open to you for redress. If you have just cause of complaint he generally at once takes the horse back. But if you buy from a gentleman dealer in horses you trust to his word and to his honor. If you are deceived, which by the by, you will find no uncommon case, what is your resource? You must either keep your bargain, or, if you hint that you have been taken in, a quarrel ensues, and you are called out for presuming to doubt the word and honor of a man who, however, in such cases, forfeits both perhaps twenty times in a year. Such men, are, however, rare among gentlemen, and I trust may long remain so. From the moment a gentleman first harbors the idea of making money by

buying and selling horses he has taken the first step toward degradation. He possibly at first, indeed most probably, had no further view than in an honorable way availing himself of his superior judgment and taste. He is "unfortunate" enough to sell three or four horses to advantage. This gives him encouragement and probably for the first time in his life he feels the pleasure of making money in a peculiar and interesting manner, and he continues to speculate with success. Hitherto he has done nothing wrong. His horses have all turned out as he represented them. He now, however, happens unfortunately to get a horse not quite what he should be. What is he to do with him? Is he to sell him at a loss? A very short time ago he would have done so, but now the itch for making money has taken too firm a hold upon him. He enters into a kind of compromise with his conscience and the horse has really perhaps nothing material the matter with him. He avails himself of his position in society and sells him on his word, as a perfectly sound horse. If he proves otherwise he does not allow he has been guilty of of a deception, but places his word of honor that he was sound when he sold him. This closes the transaction. Having thus escaped with impunity, instead of taking it as a salutary warning of the dangers of such transactions and having once been

guilty of a dereliction of honor and integrity he goes on until he unblushingly (in dealers parlance) "sticks a screw" into a friend whenever he can find the opportunity.

This is a fair sample of the usual career of those who commence privately dealing in horses. It is a pursuit that every gentleman should avoid. It is as demoralizing in its influence on the mind and eventually as fatal in its effects on the character as is the pursuit of the professed gambler. ("All fair in horse-dealing" is an idea that some persons profess). It is a very erroneous one. It is an idea that no sensible or honorable man can seriously entertain. There is no more excuse for premeditated deception in the sale of a horse than there is in any other transaction. The moment a man can bring himself to think there is he will steal.



TATTERSALLS.

If any one imagines from what I have previously written on the subject of horse dealers that I wish either to consider or intend to represent horse dealers as men in whom we may place perfect confidence, the fault must be attributed to my peculiarity of expression and not to any intention of mine, as I consider them in no such light. Confidence may be reposed in many dealers in the same way as dealers in wine or in pictures. If a man, however, is not a judge, and is not posted, and goes to either making his own purchases, he is certain to be more or less taken in; that is to say, he will not get the best value for his money. If first-rate dealers they will not venture to give you an absolutely unsound horse in the face of a warranty to the contrary, a decidedly pricked wine for sound, or a pirated copy for a genuine picture, but you will be pretty sure to get an inferior horse or wine or painting. They are tradesmen, and are in business to make money, and, while they do not dare to do anything which is absolutely dishonest, their consciences are something like that of the old Irish lawyer who considered that there was nothing dishonorable that was not contrary

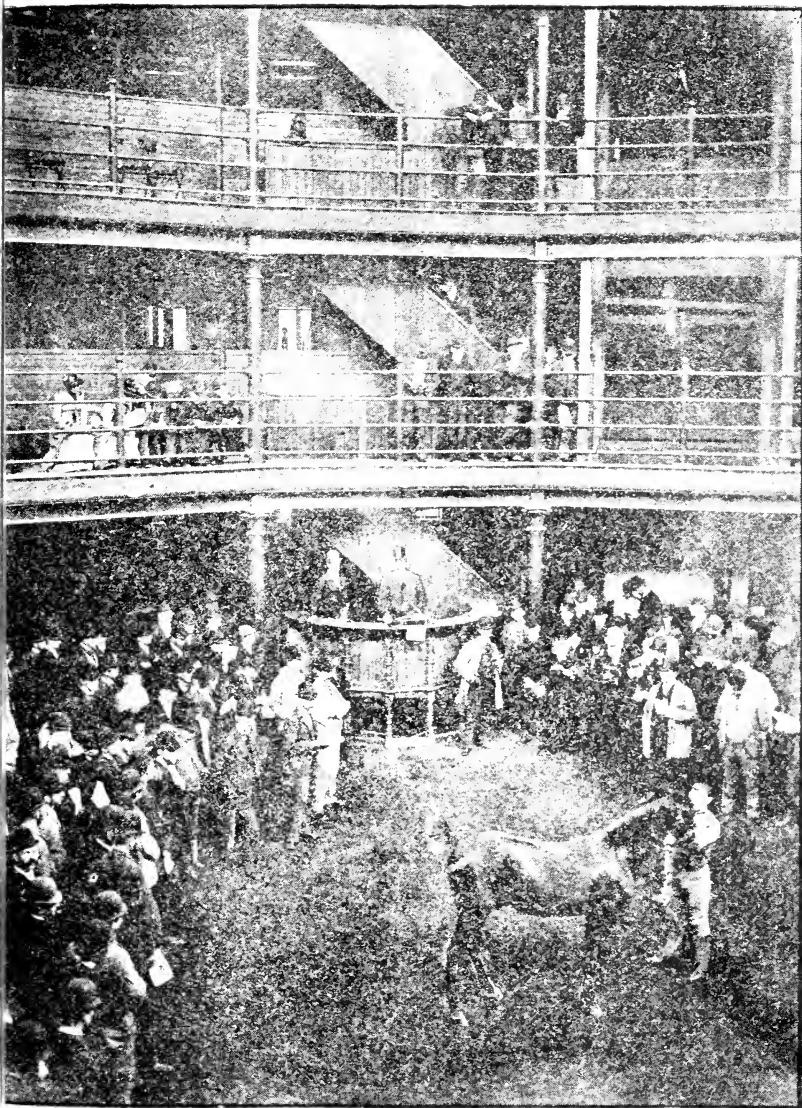

Sale Day at Tattersalls, New York.

to law. I have previously stated that I am convinced that a respectable dealer is, in the end, all things being considered, the best medium by which a gentleman can supply himself with a horse, and possibly the cheapest. If he is not a judge of a horse he has no business going personally to dealers in horses. It is far better to take some one with him, who is a judge of what is wanted, and who will keep his eyes open, and he will want both of them wide open, even in buying from reliable sources.

Another point in favor of the regular horse dealer, particularly one who has a good connection and large demand for them, is the fact that he does not limit his buyers to the price paid for them, but gives them strict instructions to buy the best. It is stated that one gentleman horse dealer, who a short time ago went West—Philadelphia or Newark—with \$2,000 and brought back eighteen horses, was credited with a great feat of buying them at less than \$50 a head than their minimum price, which was that paid by the horse car companies for what is called “streeters.” What this gentleman wanted with this class of horse is hard to determine, excepting it was to play false on intended purchasers, something like in this manner: “For Sale, the property of a gentleman; several pairs of horses of quality; all in good working condition; well broken to four-in-hand and

tandem." I do not doubt for a moment that they were in working condition, many of them having worked long enough to become a bit "shovey" in front (bent in their forelegs). Such horses were entirely unsuitable for the purposes for which they were intended, and ought to have been in the hands of peddlers or runners of junk carts.

Such pitfalls for the unwary buyer are, of course, unknown in dealing with a firm like Messrs. Tattersall, of London. That great house, which for a century and a half has maintained its pre-eminence, and has achieved a financial success and stability of the highest, has rigidly observed the rule never to buy at its own sales for resale, and never to allow a bid by an owner or on his part, except in the case of an entry with a reserve price. At the top of each regular weekly catalogue of Messrs. Tattersall the following notice appears: "The owner reserves the right to bid through his agent, the auctioneer, as often as he sees fit." The plain English of this is that there may be reserve prices, up to which point the animal will be protected by the auctioneer, and the object is to prevent the appearance of active bidding when it does not exist, and thus to guard the public from a deception that might unfairly be practiced upon it.

But when it is announced at Tattersall's that an animal is offered without reserve, every one is assured of an

absolute sale, for no owner would have the hardihood to attempt a bid, directly or indirectly, as such an attempt would only invite certain and public humiliation. It has followed from the enforcement of these rules that this house is known distinctly not to be horse-dealers in any sense, but simply as a great commission agency for those who buy and sell. It is thus entirely removed from the remotest suspicion as to its transactions. Every consignor knows that aside from the honorable traditions of the house, the amount of its commission is always dependent upon the price realized, and that its interest is blended with that of its patron. The confidence thus inspired has, of course, been one of the material agents in obtaining and holding its great popularity, and in its long history it has witnessed the rise of many a new firm, that started on the same principle but that, yielding to the strong temptation to deal covertly, fell by the wayside.

It may be said that the commission house has a perfect right to pick up a bargain when it offers, where it does so openly, and without neglect to the interest of its client, but even then it should be remembered that, in view of his usual commission, the auctioneer has an advantage of ten per cent. over all other purchasers—a fact hardly to be reconciled with business equity.

Briefly stated, the Tattersall principle is that, for its

own sake, and for the sake of its customers, it secures the best prices possible, while it leaves the plums also for the buyers at its sales. The success of the house is the best possible proof of the soundness of the principle.

The only agencies in existence of the original Tattersalls, of London, England, established in the United States, are Tattersalls, of New York (Limited), founded in 1890, and Tattersalls, of Chicago (Limited), founded in 1891, which conduct their business under precisely the same rules and methods as the parent house. Whether by auction or at private sale the interests of these houses is simply the commission, and every possible effort is made to prevent bidding up on the part of the owner, a practice as unfair as it is frequent. Whenever an attempt in this direction is detected it is promptly and vigorously defeated, and so long as this system is maintained there can be no doubt of the complete success of the new company.

Mr. Wm. Easton, who has been for many years at the head of a large and successful business of this character in this country, but which is now merged in the business above alluded to, is the managing director and business head of this new house. He is a gentleman of tireless activity, and of great experience in every branch of this business, while as an auctioneer he possesses remarkable qualities. Unlike the mere automatons who sim-

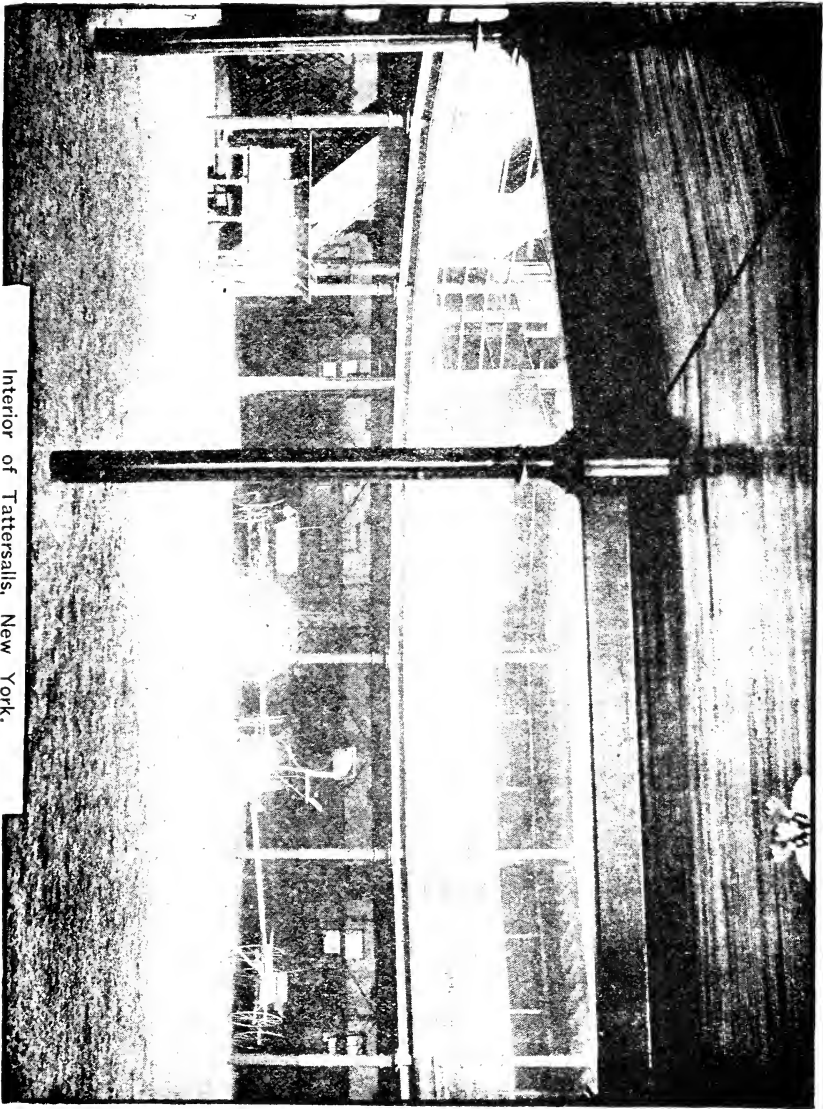

Interior of Tattersalls, New York.

ply serve to record bids and to maintain a monotonous jargon, he possesses many attributes of the born orator, and not only makes his sales interesting to casual spectators, but has a magnetic way of coaxing the coy bidders and stimulating the languid.

His latest sale of thoroughbreds—those composing the racing stable of the late Senator Hearst—was one of his most brilliant successes, but it is certain to be eclipsed by the sale of the Belmont stud, next October, which promises to rival, if it does not surpass, the famous breaking up sale of the late Lord Falmouth's stud. Mr. Easton has just conducted very successfully the first sale of hackneys ever held in America, and the esteem in which he is held by the large breeders of thoroughbreds may be imagined from the fact that he is to sell this year the yearlings from twelve of the great studs, aside from several important closing-out sales.

This company is, indeed, the first to Americanize the best English methods and to adapt them to the uses of the progressive Republic. It regards every detail that is calculated to make its establishment more popular with the best class of people. Every responsible position is occupied by a competent and gentlemanly person, and the utmost courtesy to visitors and the strictest decorum is inculcated upon all its employees. It results from this that every day many ladies walk in with as much free-

dom as if visiting a dry-goods store, and they also attend the sales in large numbers, finding comfortable chairs in the carpeted galleries. Each morning a printed catalogue of all the horses in the place, whether for public or private sale, is provided for visitors, who are thus able to select and inspect such as they are seeking, without tedious delays, and in a score of similar ways provision is made for the convenience of customers.

I have just learned that Tattersalls (of New York) have purchased an entire block in Chicago, upon which it will erect a mammoth building, to be devoted to its business. Chicago, and the vast horse-producing regions tributary to it, are to be congratulated on the fact, as they will thus secure the benefits of the admirable Tattersall methods.

Another point of interest, in referring to this branch of my subject, is the manner of warranty as to soundness. Such warranty is a very fruitful source of business vexation, and in some ways of absolute fraud. It is the fixed rule of Tattersalls, of London, not to allow a horse to be sold from their premises so warranted. For three days before a sale every animal can be examined, and intending purchasers can have their own Veterinary Surgeons report on them and thus come to the sale prepared to bid intelligently. If, for instance, the catalogue describes an animal as quiet to ride and drive and it proves fractious,

it may be returned and the money refunded. In other words, the owner's description must be perfectly true, so far as it goes, but it must not extend to soundness. The effects of this rule are equally satisfactory to buyers and sellers, and it would be a long stride in advance for business in this country if this common-sense English rule should be adopted.

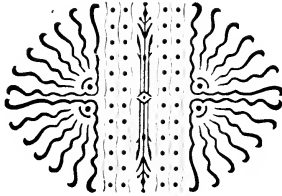

HORSE DEALERS.

We will now look a little into the character and conduct of the regular horse dealer. I know of no class of men on whom so great and—what is much more unfair—so indiscriminate a share of odium is thrown as on the horsedealer. I am free to allow there are some who are not altogether above reproach. We must not, however, from this draw the inference that it necessarily follows all horse-dealers are dishonest, but my humble opinion is that tradesmen in any other line are pretty much the same and in about the same proportion is not perhaps absolutely erroneous. The only difference is this, the horse dealer cheats one man in the day to the tune of one hundred dollars, the other cheats in smaller sums a hundred in the same time, always keeping the fact in their minds that in addition to this hundred customers he would be as ready as the dealer to cheat any one man the amount of the hundred if the opportunity offered. There is one circumstance that ought to be taken into consideration and pleads very much in favor of the fair horse dealer—supposing our purchase from him does

not answer our expectation, or perhaps his representation. That is the nature of the animal in which he deals. I know of no commercial transaction in which a man is so often deceived, and in which he so often deceives himself, as in the horse. Dealers are often, much oftener than is supposed, deceived themselves. Respectable dealers do take every precaution in their power not to get an unsound horse into their stable, they cannot, however, with all their precaution, at all times prevent this. But they will not in such a case risk their character by selling such a horse to their customers. A horse may be purchased in the country from the breeder apparently sound. He may hitherto have been so and yet before he may have been at work one week he may be the very reverse. Some hidden internal cause that the most practised eye could not detect may have long existed, the effects of which only become apparent on the animal being put to work. Here no blame can possibly be attached to the dealer. He has bought him with every warranty of soundness, has traveled him perhaps several hundred miles home, has had him several days in his stable and found him all that he expected. He has every right to think him a sound horse and as such he sold him. Still, such a horse may deceive both the dealer and purchaser when put to the test of work and change of treatment.

Vicious as well as unsound propensities in the horse frequently lay dormant for a very considerable time. When speaking of dealer's horses, I mean young ones. I am quite satisfied that where one young horse does mischief from vice, ten do it from alarm, and there is no telling what a frightened horse will attempt to do. He is a hundred times more difficult to control than the vicious one. A coachman may have driven his carriage for years in perfect safety in all situations and may be an excellent coachman, but if he suffers himself to forget he has hold of a pair of young ones without any other fault on his part, he will get into certain difficulties and danger, if not worse. The sudden stroke of the whip to a young horse who has, perhaps, never before felt it, would set him plunging at once. Going more rapidly down hill than they have been accustomed to do will alarm them, turning very sharply round a corner brings the other horse according to the turn right and left, suddenly on the pole, and confuses him. That most cruel and uncoachmanlike practice of pulling up horses sharp at the door throws them suddenly upon their haunches, causes their feet to slip and unless their mouths are made of cast iron severely injures them. There can be no doubt that the numerous accidents New Yorkers see and daily hear of—I wonder there is not more—three

out of four arise from want of judgment in driving. A driver not being aware of what is likely to produce an accident consequently takes no steps to prevent it. He probably has no conception that a strap buckled too tight or left too loose will render a horse uneasy in the harness, irritate his temper, set him plunging and finally kicking and running away. This horse might have been a week previously bought from a dealer, been driven in double and single harness, and always gone perfectly quiet and would have continued to have done so if common judgment had been used. This is all we have a right to expect from a high-spirited horse. He does not promise to carry a phaeton or a gig down hill on the top of his tail or be flayed by his harness from our carelessness. If persons wish a horse that would permit this I should recommend a wooden one. In any case of this kind, without making an investigation as to the causes, the effect having occurred, the first person usually censured is the dealer. No arguments on earth will persuade the purchaser that it arose from any other cause than the dealer having sold him a vicious horse, and he will probably feel further convinced that he knew he was so; in short, whatever failing a horse may exhibit after being purchased, whether it be in soundness, temper, constitution or anything, deservedly or not, the dealer is sure

to be set down for a rogue. I will mention a case that occurred to myself not many months since. A well-known gentleman living not twenty blocks from Central Park requested me to get him a horse to match the one he had. It was a very fine animal, sixteen hands high, of excellent conformation, extra high action, showing a great deal of quality and a fair amount of speed. Several horses were tried but one could not be got to go with him. At last, however, I accidentally met a gentleman who was leaving town and wished to dispose of three horses and at his invitation I went to look at them. One was a very fine bay and by his looks and way of going satisfied me that he would make a close match for the horse in question. I put them together and drove them myself on three different occasions and a nicer pair I never wished to sit behind. The gentleman was delighted and bought the horse. Some weeks after I received a note from him requesting me to call and see him. To my astonishment, he appeared very much displeased with his purchase and requested me to sell the horse. In reply to my question as to what was the fault with him he replied: "Why a very great fault, he plunges in his harness and rears up on his hind legs, on one occasion getting across the pole, and nearly smashed my carriage to pieces, in fact, my coachman is so frightened he will not drive him

again." I requested the gentleman to accompany me to his stable. He did so, and with his permission I asked the coachman to harness the pair. I saw where the trouble was instantly. The harness was an old-fashioned set with long bar bits and curb straps which were short and the reins being buckled down in the lower bar made it very severe upon a high-spirited horse with a tender mouth. The horse became restiye before being put to the carriage. I took the curb strap off altogether and buckled the reins in the cheek ring and with the gentleman on the box beside me, drove out. The horse acted splendidly, indeed I could not get him to go wrong. The gentleman was satisfied and wisely concluded to keep the horse and dispose of the coachman. He certainly made a change for the best.



BUYING HORSES.

There is no doubt that horse dealers in New York are heavily handicapped as to the kind of horses they have to buy. In England horses that are bred for carriage work are allowed to run till between three and four years of age. They are then bitted and broken to harness and sold to dealers, who have every convenience to finish their education. They are driven every day by an experienced brakesman through the busiest parts of the West End of London, until they become quiet and handy and get accustomed to different objects. Their style of going, the way they carry their heads and shape their necks are subjects on which no end of time and patience are spent to make perfect. The dealer now considers them so, and certainly is justified in putting them into the hands of a customer as a pair of horses fit to put to his carriage. But how different the process American horses have to go through.

They are bought indiscriminately as to age or what kind of work they have been doing. Most of them have been worked since they were able to draw. I can leave

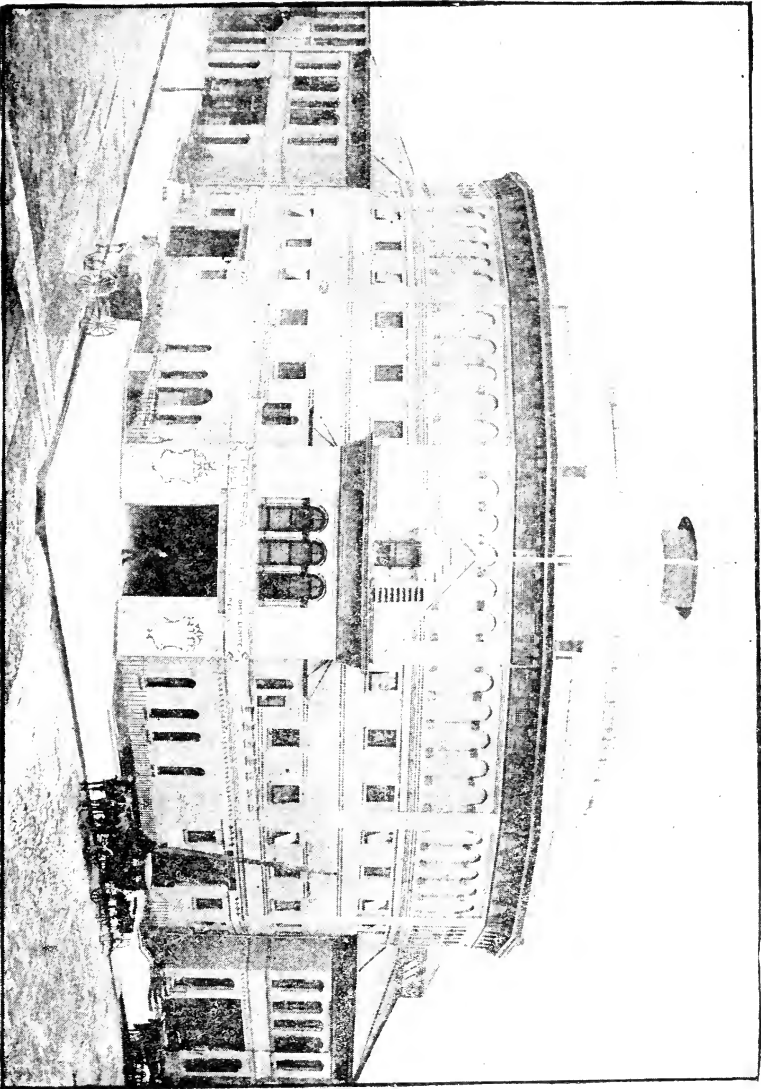

Exterior of Tattersalls, New York.

my readers to imagine the work usually done in the West by horses—plowing, logging and other kinds of heavy work. They are certainly quiet and used to draught, but never having had anything but a plain ring snaffle to guide them, and rough hands to handle them, are hard-mouthed, misshapen in their conformation for carriage work, and therefore more difficult to bit and alter their style and way of going than the young horse who has done nothing but run out since being foaled. Dealers' horses, as a rule, are or should be kept fresh from the time they arrive in the city, they get just enough exercise to keep them on edge. They are unaccustomed to the paving stones, and everything is strange to them. When being shown to an intending purchaser they are certainly shown to the best advantage; so in fact is every other article you purchase. They may have been sick with distemper, pinkeye or other diseases which young horses are liable to contract. As soon as their recovery is assured they are made up for the market, and sold as soon as possible. Their having been sick and getting only moderate exercise necessitates their being kept on short rations, just enough soft feed to keep them looking well. After they are sold, however, their treatment alters at once unless the coachman knows something, and his employer allows him to do what he thinks right. They are no

sooner docked and trimmed up than they are put into a heavy carriage, driven round the Park, and most likely further. They now get oats three times a day, and like a child with a box of candy, eat till they get sick. The regular work is beginning to tell on them. They get dull, their lack of condition begins to tell, they have no ambition to step, and therefore lose whatever action they might have had when bought, and, excepting the horses were well mated, of good color and proper conformation, look mean and worthless. Many young horses are ruined through injudicious driving and improper treatment that would in experienced hands otherwise make up into good, useful animals.

I venture to surmise that amongst my readers there are some who, when buying horses, have been so impressed with their high stepping qualifications as to lose sight of the other points which go to make a perfect carriage horse, without taking into consideration the forced state of condition of the animal, or whether he or they are suitable for your purpose, even if they did not have the extra high stepping qualities. You bought them simply on account of their action not knowing how or from what cause that action was produced, and after working them a short time have become disgusted with your purchase because, they having

lost the courage and ambition, as well as action they had when bought, being ignorant of the cause, you either blame yourself for buying them or blame the dealer for having deceived you.

I once heard a lady remark to her coachman, "Robert the horses don't step near so high as they did when we bought them. Do you suppose the dealer put anything into their feet to make them act?" Now, I dare say this question has been asked more than once, and some people are stupid enough to imagine that the dealers use artificial means to make their horses step high whilst being sold, but I can assure my readers they who imagine so are wrong in their surmises.

The wealthy people of New York are not so fortunate as their friends in equal circumstances in the large cities of Europe, who can go to any one of the several large sale stables and select a pair of horses which, if they buy, they will find are not only well matched and thoroughly broken, but have good manners and fine mouths and every other essential point that time, patience and experienced handling could effect. How different the experience of buyers of such horses in New York! I have known a dozen different pairs of horses sent to an intending buyer and all returned as unsatisfactory through some defect, difference in size, color, way of going or whatever it might be, which the dealer

perhaps never noticed, and even if he did, in some cases would not know how to remedy. Some people are much easier suited than others and will go to a dealer and buy a pair of horses providing they look alike in color and size and the price moderate; they not having the slightest thought of any other indispensable qualifications desirable in a carriage horse. Even the dealer himself unless he has had a long practical experience with such kind of horses, cannot be expected to know what is necessary to be done to make up a pair of horses so that they are ready for use, go handsomely and carry you safely and pleasantly.

I have said that all horses are not made alike. The way in which a horse would in a natural state carry himself depends wholly on how he is made, and how he will carry his head depends on how that head is put on to his neck and how the neck is put into his chest and shoulders. The mouth in its natural state has, of course, nothing to do with this, but when we take him in hand it is by acting on his mouth alone that we must trust to bring the head and neck into proper position; indeed it is acting on the mouth that enables us to perfect the general carriage of the body and to alter, if necessary, the whole system of going. It may be said that the mouth has nothing to do with the natural formation of the neck. This is true, but it has a great deal

to do, not only with the way in which that neck is carried, but positively—to a certain degree—altering this natural formation.

This is all Greek to those horse dealers in this city who buy and sell horses like shoestrings, for a small profit. But to those dealers who buy slowly and make a business of matching horses as they should be matched, and bit and drive them until they become perfect, these few words of advice will not be thrown away.



HIGH STEPPERS.

A roadster good, not straddling high,
Nor shuffling low I find thee,
But stepping straight and cheerily
Dost leave the miles behind thee.

It is considered by some persons the height of perfection and style to have a horse with a high knee action; so it is, providing he acts all round and in every other way shows quality, but merely lifting his front feet higher off the ground than another horse, does not constitute a high-stepping horse in the proper sense of the word. A horse that has more than ordinary action in front should have the same behind in proper proportion to make it natural. I must admit there are very few that come up to this standard. It looks ridiculous to see a horse go along picking his front feet off the ground like a cat on hot bricks, at the same time shuffling the hind ones along the road. A horse that acts this way, except in very rare cases, has speed, but is generally too slow for ordinary carriage work, the reason being that the horse obtains his propelling power from the hind legs, and the higher he picks them up when going the further he strides. Take for instance the

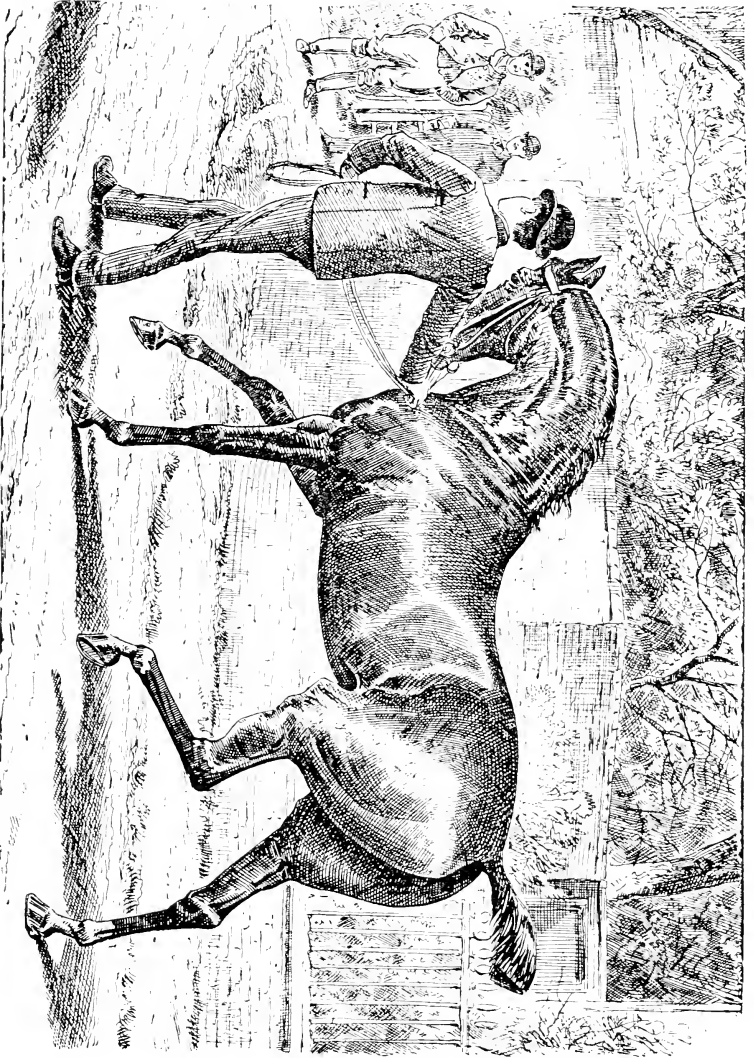

A GOOD SORT.

“Devil,” a black horse owned by Mr. Stokes, well-known to most horsemen in New-York. He is far away the best all round going horse in New York, and I believe can trot close to three minutes. I have seen horses that go higher in front, but when urged to their utmost, could only go eight or ten miles an hour, because they did not have the necessary amount of action with the hind legs.

There is a diversity of opinion as to what constitutes pretty action, and each man may harmlessly indulge his taste in this particular. but there should be but one opinion as to what is proper action. Some horses step short when going and bend the knee under the body, doubling the legs up in a circular style, and bring them down heavily, bringing the weight of the shoulders with them; these are called “Pounders,” and soon lose their action, besides getting sore and fever-footed. These kind rarely step true, either dishing a little outward or inward, in some cases causing them to interfere. By weighting and proper shoeing these faults can sometimes be rectified.

The true-actioned horse steps from the shoulder, bends the knee in front, and steps out gracefully, bringing them down light and easy. It is but natural for a horse of proper conformation to do so, and so long as he is kept in high condition, does not get too much work, but

sufficient to keep him in exercise, will always retain the same amount of action, and if a young horse, can be made to improve if driven by an experienced coachman.

Flashy going horses, with extra high action, are not adapted for hard work or rough roads. They tire sooner than plain goers. To those persons who own and drive high steppers I advise them to work them as little as possible on the pavements and drive them moderately on the road. Never drive them at top speed, but let them go a little within themselves, the principal thing being to keep them in good condition. High feeding and good care is the mainspring from which they obtain the courage and good spirits that tends more than anything else to make them step.



C A P P E R S .

There are no class of men so useful to intending purchasers of horses as a respectable capper, one who obtains a livelihood selecting horses and finding customers for them. To some persons the name will no doubt imply something wrong or illegitimate in regard to buying and selling horses, but I can assure my readers that it is often through the judgment and experience of these men the driving public are enabled to obtain matched pairs and extra good carriage horses at reasonable prices. Only for the class of people amongst whom they have to associate, and the line of stock in which they trade, I cannot see any difference between them and stock brokers. They buy from one and sell to another, and vice versa, in most cases by request at a margin or commission, in fact cappers are in my opinion more useful to those who buy horses than brokers are to those who buy stocks, for the simple reason that cappers are scarce, while brokers are plentiful. Cappers are in every way as necessary to dealers as to buyers, they being acquainted with every sale stable, and constantly moving from one to another, they note

every horse of quality in each, which often enables dealers to match horses and make pairs. Buyers can save themselves a great deal of unnecessary trouble by employing one of these men, for knowing everything in the market, they can show you whatever kind of horse you may require, and their judgment is generally good. If you go into a dealer's stable by yourself you will perhaps be persuaded to buy a pair of horses that will not really suit, you buy them thinking perhaps you can do no better elsewhere, whereas there might be horses in the market that would suit your purpose better, if you only knew where to find them. It is therefore advisable to secure the services of some one who can be depended upon to select horses which, in the first place, are suitable for the desired purpose, providing that the person is one who is known to have had practice and experience among high class carriage horses, and who knows how to put them together and drive them. Unless he does, it is next to impossible for him to tell whether they are the right kind. There are many different kinds of horses, and as many different kinds of vehicles for them to draw. It is therefore most essential that some one, be he buyer, dealer, capper or coachman, should know for which each is most suitable. What I wish to point out is this a man may be a very good judge of one description of horse and for the purpose for which he is

required, and be ignorant of the merits and good qualities of another kind. Every man to his trade, and there are several branches in the horse business, each one requiring a lifetime of study and experience to become competent. As an illustration, a man might be an excellent judge of a draft horse and be totally ignorant of the points of a race horse, and a good judge of a trotter, yet be absolutely lost in the selection of a coach horse. I advise those wishing to obtain a good horse to trust to the judgment of a recognized representative of each class. It is much better to employ a capper who will, for his own reputation—being indifferent as to what dealer you purchase from—than to trust to a friend or amateur horseman who believes himself to be a good judge. In nine cases out of ten the latter, whoever he might be, will more likely, in his ignorance, prevent your buying a good horse that would suit you and be of good service.

According as the revival of fashionable turnouts demands the use of coach horses to replace the long-legged, lofty, rangy sort that were formerly used, there are other and more important points besides to consider. A man who all his life has been used to ride in low-seated wagons with pole and yoke, and drive horses suited to such, cannot possibly have much conception of the kind of horses that are suitable for the present

kind of vehicles used. If I were commissioned by a person to get a fast trotting horse I should not undertake to fill the order without going to some horseman whom I knew was a thorough judge of trotters. How a man who has been used to handling nothing but trotters should be considered an expert, and his judgment required to buy coach horses, is entirely beyond my field of comprehension. These are the kind of men who, whenever describing the qualities of a horse they have for sale, never fail to assure the intending buyer that he can go a three-minute gait. Whenever the mention of speed is so forcibly brought into requisition as the chief quality of the horse, it is time for the buyer to look elsewhere for a dealer, who thinks more of the points and appearance of the horses he keeps for coach or carriage work. No one with any common sense wants or expects to be driven twenty miles an hour through the park. If they ride along a six-minute gait they will find it quite fast enough for town or park driving, and in the next place trotting gaited horses are unsuitable and entirely out of place in a carriage. They are, as a rule, hard-mouthed, long-gaited, and therefore awkward in turning and unsafe to drive on the stones or asphalt pavements.

FEEDING.

“Bone and muscle go in at the mouth.”

The proper feeding of horses intended for driving is of the utmost importance, and I am sorry to say that it is very much neglected. As a general thing a horse gets four quarts of oats three times a day and a fork of hay at night with perhaps a bran mash once or twice a week. All horses not being alike in their constitution or appetite it is quite natural that what will fatten one will not fatten another.

Good feeders or greedy horses should have their oats mixed with chaff (cut hay). By this means the animal is compelled to chew his food¹ as the chaff being too hard and sharp to be swallowed with sufficient mastication, he is forced to grind that down, the oats and corn are consequently ground down with it and yield much more nourishment. The stomach is more slowly filled and therefore acts better on its contents, and is not so likely to be overloaded. The increased quantity of saliva thrown out and the lengthened mastication of the food softens it, and makes it more easy of digestion. It is

necessary that the hay selected to be cut be of good quality and clean. It is not advisable to use the baled hay, as it is generally dusty. Horses of weak digestion or defective teeth will improve on this kind of feeding, especially if the oats are bruised.

The mixture of chaff with the oats prevents it from being too rapidly devoured and a portion of it swallowed whole, and therefore the stomach is not too much loaded. It is on the food that contains the most nutriment that the chief digestive power should be exerted. Yet, on the whole, a great deal of time is gained by this mode of feeding and more is left for rest. When a horse comes in wearied or tired it takes, after he has eaten his grain, two or three hours to clear his hay rack. On the system of manger feed, the chaff being already cut into small pieces and the corn and oats bruised, he is able fully to satisfy his appetite in an hour. But if the hay-rack is full the greedy horse will be eating all night instead of taking rest. When the time for the morning feed arrives his stomach will be already filled, and he will be less capable of work, from the want of sleep and from the long continued distension of the stomach rendering it impossible for his food to be properly digested. Two additional hours will therefore be devoted to rest. This is a circumstance deserving of much consideration even in the private stable, and of immense consequence to the

livery stable-keeper and the owner of every hard-worked horse. The quantity of oats must vary with the size and the work to be performed.

Bran or the ground husk of the wheat is useful as an occasional aperient in the form of a mash made with boiling hot water. Before using allow it time to steam through, and if mixed with an equal quantity of bruised oats is very beneficial for horses suffering from cold or cough or to build them up when recovering from sickness, but it is wrong to use it as a regular article of food, as is often the case. Frequent cases of indigestion are caused from the accumulation of bran in the large intestines, and when wetted with cold water it is positively injurious.

The virtues of carrots are not sufficiently known, whether it be in contributing to the strength and endurance of the sound horse, or the rapid recovery of the sick one. To the healthy horse they should be given sliced, in his chaff. They also improve the state of his skin, forming a good substitute for grass, and an excellent food for horses out of condition. To sick and idle horses they render grain unnecessary; and are not only serviceable in diseases of the skin, but have a marked influence on chronic coughs and broken wind. In combination with oats they restore a worn-out horse much sooner than oats alone.

The time of feeding should be as equally divided as convenience will permit. When it is likely that the horse will be kept longer than usual from home the nose-bag should invariably be taken. The small stomach of the horse is emptied in a few hours, and if it is allowed to remain hungry much beyond the accustomed time he will afterwards devour his food so voraciously as to distend his stomach and endanger his system generally.

One of the most successful methods of enabling a horse to get well through a long journey is to give him only a little at a time while on the road and at night to indulge him with a double feed of grain and a full allowance of hay or chaff.

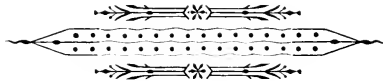

SHOEING.

Far more than is generally imagined does the comfort and health of the horse and the safety of his rider depend upon shoeing. Horses used for carriage or light harness work should have plain shoes on the fore feet, and they should never be heavier than the work requires. An ounce or two in the weight of the shoe will tell greatly at the end of a hard day's work. Having the front shoes turned up, or calkins as some do, prevents the horse from obtaining the assistance that nature provided in the frog, which must be left so far projecting and prominent that it will be just within and at the lower surface of the shoe. It then descends with the sole sufficiently to discharge the function that it was intended to do. If it is lower then it will be bruised and injured; if it is higher it cannot come in contact with the ground, and thus be enabled to do its duty. Coachmen who cannot drive horses shod plain in front with perfect safety should seek some other mode of obtaining a livelihood.

The hind limbs of a horse being the principal leverage in propulsion, except in walking, the toe is the point on

which the whole frame of the animal turns and from which it is propelled. This part, therefore, should be strengthened as much as possible, and the hinder shoes are consequently made broader at the toe than the fore shoes. Another good effect that is produced by this is that the hinder foot being shortened there is less danger of over reaching or forging, especially if the shoe is wider on the foot surface than on the ground. The shoe is thus made to slope inward, and is a little within the toe of the crust.

In assisting horses in drawing heavy weights up-hill a very great deal may be done in a way that is very often overlooked, viz., by a proper hind shoe. Horses used for harness work should have calkins on their hind shoe because the animal will be thus enabled to dig his toe more firmly into the ground and push himself forward, thus throwing his weight into the collar with greater advantage. The calkins however must not be too high, and they must be of an equal height on each heel otherwise the weight will not be fairly distributed over the foot, consequently some part of the foot or leg will naturally suffer.

I doubt not that many of my readers when riding on a coach going up-hill have observed the leaders, who ought to be called upon pretty freely at such times, and noticed the twisting of their hocks and indeed the whole

leg from side to side. This chiefly arises from the bad form of the shoe. It is quite clear that in going up steep hills the toe of the hind foot takes the first bearing on the ground; indeed some horses on these occasions hardly press the ground with their heel at all. It must be quite evident that the greater expanse of bearing we give a foot on the earth the firmer must be the tread, and as the hind foot is the great fulcrum by which a horse gets uphill with a load, too much attention cannot be given to effect the firmest hold for it. The toes of shoes are very naturally made round or nearly so, the consequence of this is that the horse's toe comes to the ground on a very small segment of a circle; in fact on a pivot, the effect of which is that the foot turns to the right and left and the legs and hocks naturally turn with the turn of the foot. This of course produces the twisting of the hocks I allude to, and the leg not being able to keep straight the horse loses a large portion of his power. Spavins, curbs, thoropins and strained ligaments are the future and fatigue the immediate consequence of such neglect. The shoe should be made square at the toe, to the very extreme verge of the foot. Surely it is worth the trouble to see that a horse is properly shod when we can increase his powers and comfort so much by doing so.

THE AUCTION MARTS.

The auction mart conducted as it ought to be is a fair place to either buy or sell horses, but a concern which depends chiefly upon its own animals really hangs out the red flag simply as a disguise. It is unfair to both buyer and seller. A person may possibly wish to dispose of a horse or some other property; and if the sale is legitimately conducted the highest bidder obtains, but if it is sent to a mock auction mart the firm buys all the bargains for themselves. They will know more about them than any intending buyer, having a better chance to find out and try them. If they think they will suit they are shown to a disadvantage the first time of offering and consequently knocked down cheap to a representative of the firm. Neither the seller nor the public get any benefit, the concern gets all. But how different the following sale day! If it be a horse it is shown with an appropriate harness in a suitable vehicle, and the public are then given plenty of time to bid. I don't wish to imply that the purchaser, whoever he might be, is swindled, what I wish to infer is that the seller got less than he really would if his horse had been

shown under the same advantageous circumstances, and the buyer paid more than he would if the horse had not been so well advertised and shown. Each one lost money, and yet the horse brought in most cases double the amount of what the original owner obtained for him, showing clearly that the concern got the most profit. Anyone with ordinary intelligence can see this thing enacted every week in this city. There are times when a person can get a really cheap horse, but it requires knowledge, good judgment and the courage to bid. I bought one of the best horses I ever owned at an auction. The previous owner of the animal, who I should imagine was ignorant of the regular mode of entering a horse for sale, did not guarantee the horse in any way, in fact the horse was put up with the understanding that he was to be sold as he stood, or, to use the auctioneer's expression, "not warranted to be alive." But happening to be in the neighborhood of the auction the day previous to the sale I noticed a dark chestnut horse hitched to a buggy being driven up and down the block. The horse went wonderfully well, and on the following day I recognized the same horse being put up for sale. Having such an unsavory pedigree the bidding was slow, and just as he was about to be knocked down I bid and I soon began to find I was bidding against the house, or more pointedly, the auction concern wanted him themselves. I made up

my mind to have him and bought him for \$125 and a very cheap horse he turned out to be. He was six years old, perfectly sound and I could not hitch him wrong. Good under saddle, and he could trot close to three minutes; in fact he was a perfect all-round horse. During the time I was bidding a well dressed man who stood close to me made the remark: "Why, that is the horse that ran away with a lady, he looks like a bad one," but his person looked familiar to me and I came to the conclusion that he was a steerer employed by certain individuals to try to stop anyone outside of the concern buying and therefore took no notice of him.

Persons unaccustomed to the roguery and tricks employed at these auctions should be very careful when selling any article to properly specify the relative merits of whatever they might enter for sale and personally attend the day of sale if convenient or have some authorized agent go there and note that the entry gets proper attention. To those who wish to purchase I advise them to find out, if practicable, the legitimate owner, and if it is a private person who sells through want of use you can then bid with safety what you think is a fair price. Always be careful to avoid trying to buy a horse that belongs to a dealer or especially one in which the concern is interested as you will in all probability get the worst of the deal.

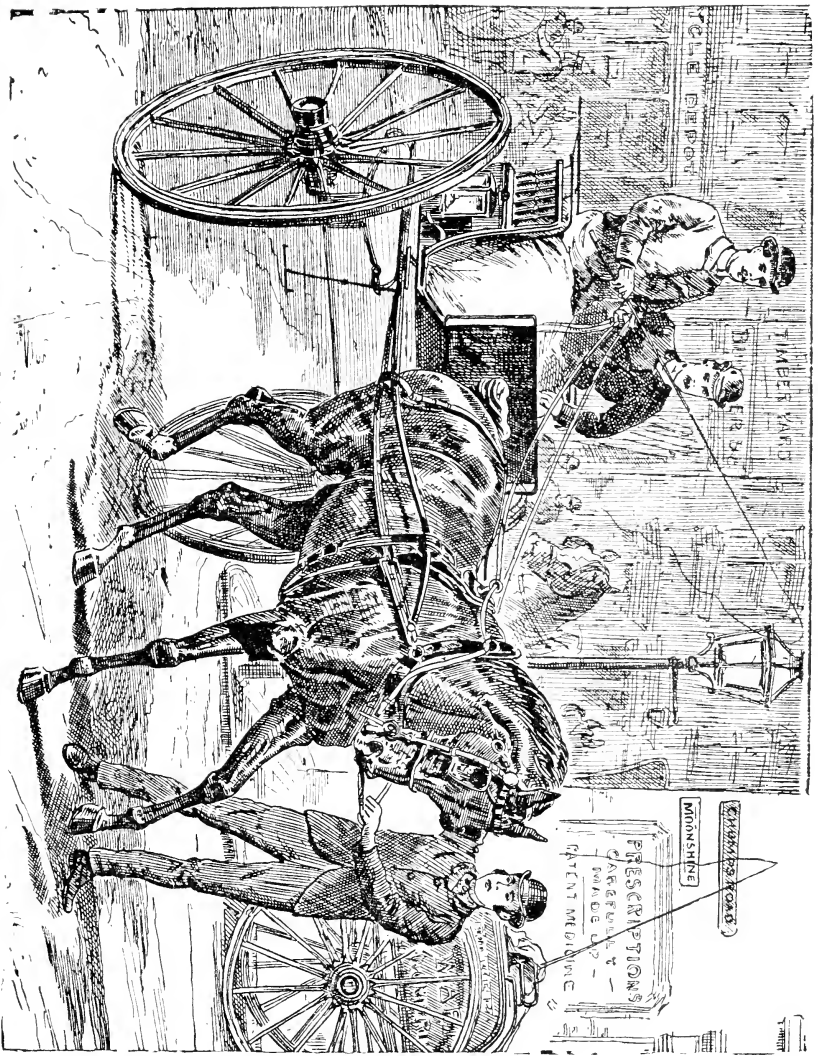

INCLINED TO BE TRICKY.

MUNSHINE

PRESCRIPTIONS
CAREFULLY
MADE UP -
PATENT MEDICINE



HORSE SHOWS.

The large attendance as well as the number of exhibitors at the recent horse show at Madison Square Garden proved conclusively the great interest the American public takes in the horse of every description. If the annual show is run as it ought to be, in a fair and impartial manner, it will conduce more than anything else not only to enlighten but to create a certain amount of honest and healthy rivalry among the owners and lovers of this most useful animal to own and breed the best.

There were, unfortunately, good reasons for the dissatisfaction shown not only by the public but by the exhibitors themselves in several classes. I do not intend to go into all details respecting the judging, but may mention one or two cases which I particularly noticed as being wrong to the exhibitors, showing lack of knowledge on the part of the judges or perhaps discriminating favors. The first point to consider before criticising or condemning is whether the judges were competent to fulfill the duties imposed upon them. If not, the blame falls on those who selected them to fill

such an important position. From personal experience during the last show, I came to the conclusion that the personal merits of the owners and their relation with the Association were considered more than the merits of the horses they exhibited. In one class I noticed a good deal of indecision on the part of the judges as to which was the best horse, and they could not decide until they referred to the catalogue, and I audibly heard the remark: "Give it to those; they belong to Mr. ——."

The most farcical part of the whole performance was enacted in the class for tandems, where a pair of ponies driven by a gentleman connected with the Association was awarded a ribbon over one that on the following day deservedly got the highest reward as the best in the show. "In and out" judging like the above, no matter whether through ignorance or personal feeling, does more to injure the development of horse shows than anything else. The horse-loving public go to see and learn what is considered the best tandem. How is it possible to do this when one day a pair of ponies beats a pair of horses and the next day these same pair of horses beat the pair of ponies? The only standard that should be recognized and the one that will tend to popularize a horse show is that of merit. The owner has nothing whatever to do with it, or ought not

to have if the judges were impartial as well as competent.

There was a marked diversity of opinion upon the awarding of the prize for professional coachman. The one selected certainly had no right to it for the simple reason he did not drive the course laid out. After making the figure eight, his hands being on a level with his chest, through putting on too much side, he found too much rein to alter quickly, so instead of going between the post and stand he came straight down and finished. Besides this it was unfair to allow him to use a skeleton brake to compete with coachmen handicapped with a drag which takes twice the amount of room to turn in, and strange to say the only coachman competing in this class who utterly failed to show any ability with a team, in fact, the only one out of seven who had the honor of knocking over a post, was awarded the prize the next day for pair-horse coachmen. Besides this he was competing against the same men who the day previous outclassed him in every respect. In the face of such a decision, what contempt must the driving public have for it, and those who are not so well posted must conclude that the safest way of receiving the blue rosette, is one of incompetency. Private coachmen should not have been allowed to compete. They should have been or-

dered out of the ring, for, according to the reading of the entry (for professional coachmen), they were entirely out of their class. It is therefore next to impossible to expect fair and impartial judging from those who are not only deficient themselves in all that is requisite to be a coachman, but are entirely ignorant of the difference in classes of which they are supposed to be experts.

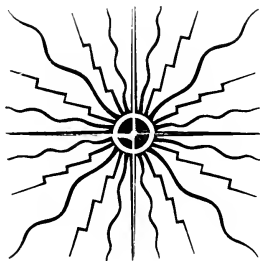

WHAT TO DRIVE.

I may surprise some of my readers who have been driving perhaps for several years and who believe that they are perfect, having nothing to learn, if I inform them that being able to drive well does not make them coachmen any more than being able to drive a fire engine makes a man an engineer. There is nothing, in my opinion, looks more ridiculous than to see, as is often the case, persons driving a cart with a horse entirely out of proportion to the size of the cart, the harness ill fitting and not in its proper place. The pad (or saddle), in most cases, instead of being on the horse's back forward on the withers, the crupper strap too long, the collar too big, and, worst of all, the cart not properly balanced, causing the occupants to pitch backward and forward in the most uncomfortable manner. This is no fault of the cart, but the fault of those who drive not knowing whether the height of the shafts and wheels are in proper proportion to the size of the horse and the body weight of the cart in order to have it properly balanced. Properly balancing a cart insures ease and comfort to the oc-

cupants, and makes the work much lighter for the horse. Some people say that a horse tires sooner in a cart than in a buggy. I can explain the reason in a few words. The horse drawing the cart has twice the weight to pull that the buggy horse has. This is equalized if the cart is balanced right by having only two wheels to pull over obstacles, where the buggy has four. We must not expect the horse to draw and carry the weight on his back at the same time. What is it that makes drawing boats or barges so distressing to horses? The constant weight on their shoulders from their having no declivities to relieve them. So it is in a mitigated sense with a horse in a cart. He is always or comparatively so at work. A very great error existed for a long time as to the proper application of weight to horses in two-wheeled vehicles. With some these probably exist still. The error arose from the evident conclusion that the more weight we throw on the horse's back the less there must be on the wheels, and to carry this thing out a much greater proportion of weight was put before the axle in old gigs than in modern ones. Nothing certainly could be more absurd than to suppose this was advantageous to the horse, and yet many sensible men entertained the idea. If we take say 100 pounds off the wheels and put it on the horse's back the wheels would certainly

make a 100-pound less impression on the road, being that much lighter, but it by no means follows that the change is in favor of the horse—common sense tells us that it is the reverse—if the changing of the 100 pounds was advantageous it must follow that if we

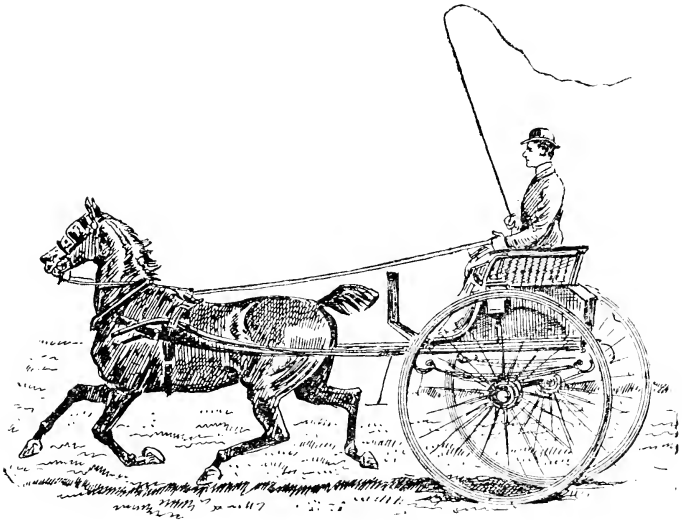

A ROADSTER.

could pack the two persons, cart and all, on his back it would be better still, and so on till in lieu of a horse drawing a ton of hay we should be making the experiment of trying how he could carry it, in which I rather imagine we should fail. That the

weight hanging back so far as to cause any exertion of the horse to keep it down must be a useless expenditure of strength is quite certain; the desideratum is to give him if possible increased hold of the ground, but putting any portion of weight on his back that he can so easily drawn is preposterous. A fact has often been proved on the other side to this, put a load behind a horse which he cannot move and then put a 200-pound man on his back. He will draw it. This only shows the effect of increased weight against weight. But it would be rather a curious manoeuvre to make a 200-pound coachman ride one of a pair of horses in order to facilitate their going ten miles an hour in harness even allowing that we took the 200 pounds from the carriage. In many ways the power of horses is wasted quite as ridiculously from want of consideration. It is quite clear that whatever presses against the front part of the axle has a tendency to drive the wheels back, while whatever acts upon his back part has an opposite effect.

All carts should have nearly straight shafts, with a slight turn outwards towards the end. The White-chapel cart, which is mostly used for tandem, is built with straight, stiff shafts. Before purchasing a cart it is advisable to get some one to hold the shafts; then take your seats and you can easily see if the cart is balanced

right. If it is, the shafts will stand out perfectly straight, and the slightest touch will raise or lower them. The next most important part of the turnout is the harness, which should be stronger and with more substance than harness used for four-wheeled vehicles, the pad made with strong girths, the tugs large enough to give the shafts room to play, the back band made in one piece, with one buckle on the near side, and care should be taken when putting too that the back hond is left loose. If, as is generally the case, the back band is drawn tight, there is no chance whatever for the cart to balance itself; consequently, every time the horse steps the shafts, being like a fixture, cause the cart to jolt. Breechings need not be used in town, but I strongly recommend their use for country work; but, when the breeching is dispensed with, a loin strap, or, as it is termed, kicking strap should be used. It looks well and is much safer. It is impossible to tell when a horse might start kicking. I used a horse several years and he never made an attempt to kick till one day going down a very steep hill a flock of geese came out suddenly from a gate across the road. I pulled up suddenly to avoid running over them, when, having no breeching on, the sudden jerk threw the weight of the cart against the tugs, therefore pulling on the crupper to such an extent as to cause the horse pain, and he, not liking such treatment, kicked.

Had it not been for the kicking strap he would in all probability have kicked over the shafts, and it is impossible to tell what the consequences might have been.

The most suitable horse for an ordinary cart should not be over 15.3; one that steps quick and light, moderate action, with a good head and neck well set on him, with substance and breeding combined. Cobs from 13.3 to 15 hands are used for village or Surrey carts, and look neat and stylish, provided the cart is well set up and not too low in the body. A cart, no matter how the shafts are made, cannot balance or ride easy unless the height of the wheels and axles are proportionate to the size of the horse or cob.

Stanhope and Tillbury gigs, being built on a different principle, are more easily adjusted and can be balanced before leaving the coach builders, as they are not intended to carry more than two passengers. The shafts are also different, being turned in to a considerable extent, so that they lay close to the pad. Gig harness is generally made with French tugs, which are more suitable for these kind of shafts, as they do not require the same amount of play that a straight or stiff shaft does. For neatness, style and safety there is no better vehicle made than the two-wheeler. No matter how short a horse might turn the two wheeler turns with him. They are used exclusively in all the principal cities in Europe,

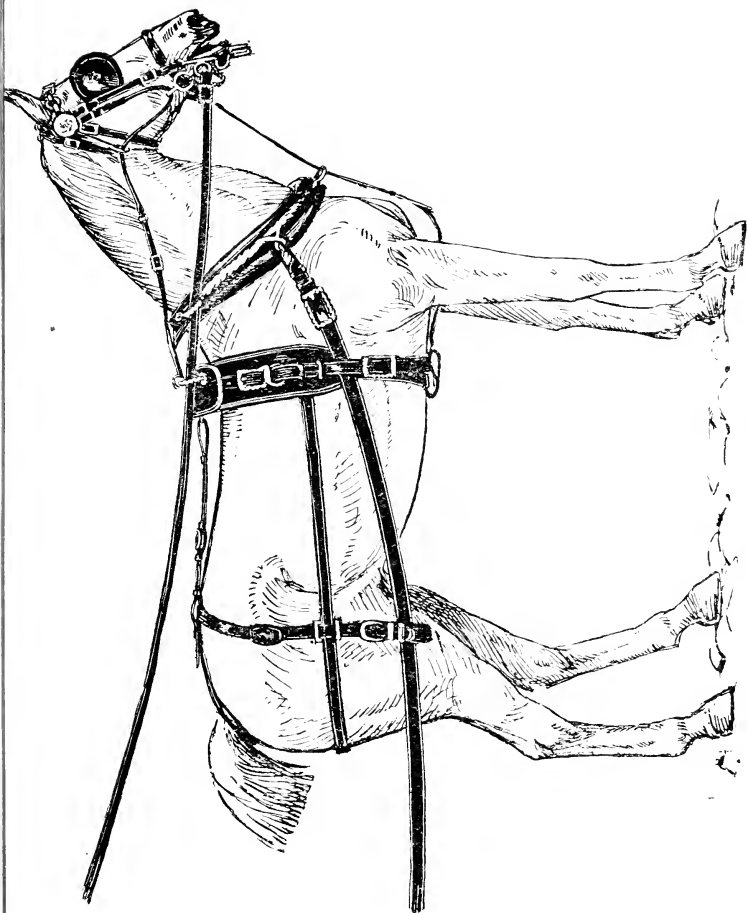

FALSE BREECING.

especially by horse breakers and dealers, being considered the safest for handling young horses. Cob and pony carts are more adapted for ladies and young people.

Single brougham horses require breeching, there being a good many stops made driving through a busy crowded city. But if you don't wish to use breeching, a loin strap and false breeching is necessary. It buckles on the pad, which prevents the pad moving forward, therefore taking the strain of the crupper strap.



HOW TO DRIVE ONE HORSE OR A PAIR.

Driving one or a pair being the same thing as regards the position of the reins in the hand, I will endeavor to show my readers, with the aid of a few diagrams, how to drive in a correct and proper style.

In the first place you must sit up as straight as possible on the driving seat, but sit comfortably—not half

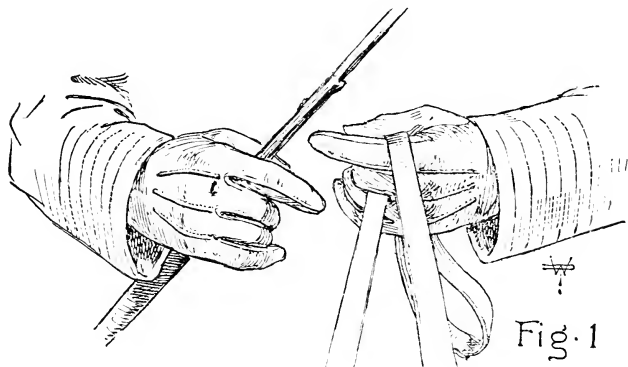

standing as some do. Hold the reins in the left hand; the near rein on top, the off one below, between and in the middle of the second and third fingers. Hold the whip in the right hand, and keep both hands in the position fig. 1. Always be careful to have both reins even

in length and just tight enough to feel the mouth of the horse gently. When starting off, either with a click or slight touch of the whip, drop your left hand a little, that is, push it a little forward so that when the horse gets into his traces and extends his head and neck he will not feel himself checked in his endeavors to start. Some horses, especially those with a bar or Liverpool bit buckled down, and perhaps a tight curb, will baulk or get out of temper. Double ring snaffles are the best bits to use for cart work unless your horse is a very bad puller and even then if used with a nose strap, the reins buckled in the single ring will hold him. In fact I have used them myself repeatedly on horses whose mouths were calloused and hard from the severe use of a curb bit. Some horses after pulling awhile against a curb get their lower jaw numbed and lose all sense of feeling. Now, having started off all right you might wish to take your horse back a little or take a shorter hold of the reins. If a lady or young person be driving they can pull the reins through the fingers of the left hand which is easily done by putting the right hand back of the left and taking firm hold of the reins, at the same time pushing the left hand forward and so letting the reins slide through the fingers until the necessary length is through. Do not separate the reins, that is, holding a rein in each hand. You can do all the turn-

ing or stopping required with the right hand. Driving with a rein in each hand is really dangerous, especially when they are loose, it being impossible to pull up quick without, as is oftentimes done, throwing the body right back with the hands up to the chin, and not being able to pull any more, holloa "whoa" or run into something. To pull up short and to do it properly is very simple and

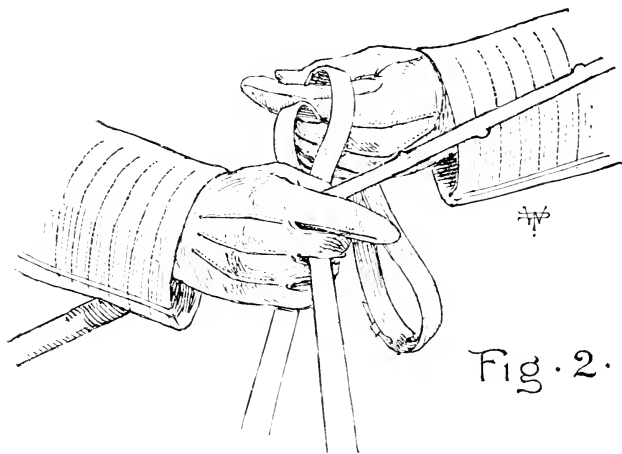

Fig. 2.

easy, in fact it is similar to pulling a rope hand over hand. Your reins being in the left hand the right is at all times free and ready to assist. Put your right hand over and in front of the left as far as it will go, and catch hold of the rein as fig. 2 and pull towards you. If that is not sufficient keep the reins in the right hand

leave go with the left, at the same time pushing under and in front of the right (fig. 3), and you will find that you have them in the same position as when starting. It is well to practice this, taking up the reins quick with each hand, always bearing in mind that when taking them into the right hand the fingers are turned downward and when in the left the fingers are upwards.

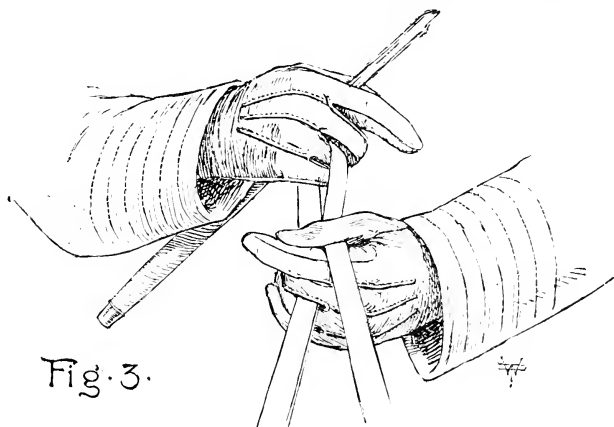
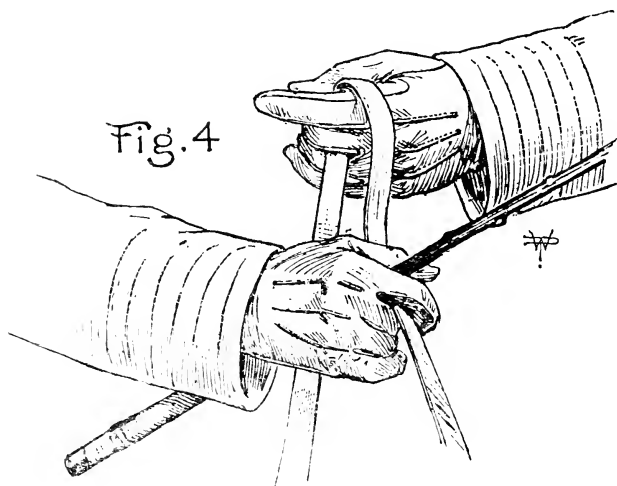

Fig. 3.

To make a turn to the left place the right hand over and a few inches lower than the left of the near rein and pull, as in fig. 4. A nice mouthed horse only requires a slight touch. Keep the hand there until the turn is made. In case the horse turns too quick or too sharp your hand is ready and convenient to steady the off rein, and if you want to pull up short you can easily

do so. Turning to the right comes a little more easy, as you just place your right hand on the off rein and with the top finger projecting, as in fig 5, can easily grasp the near rein or both at the same time, and so come to a sudden stop again if necessary. If you learn to drive



the way I have described you will find it easy, safe and stylish.

Driving a pair, if properly bitted and reined, is similar to driving one, but it requires a practical coachman of experience to have them in their right place. I was once asked by a lady if I would teach her to drive. She wished to be considered the best lady driver in New-

port. The lady I allude to had been driving some months, and sat on the driving seat in a very coachmanlike manner, and understood perfectly how to hold the reins. We went out, and with some little difficulty got to the park. The lady had been driving and complained of being tired. I noticed that from the time we started she had been driving mostly on one rein, and

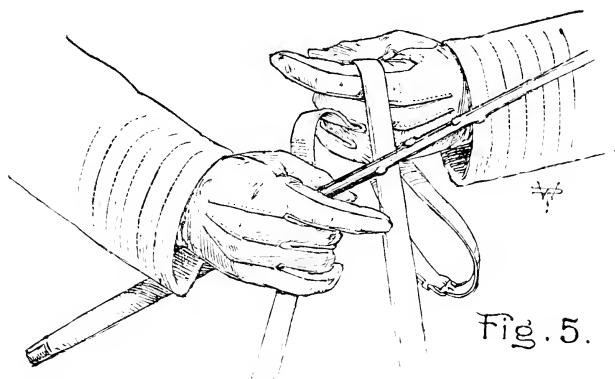

Fig. 5.

even then could not get the horses to keep straight. I changed seats, and had not driven many yards when I found out where the fault was. The cobs were young and improperly bitted, the near one had more ambition, combined with a harder mouth, consequently when driving with a loose rein did most of the work, thus forcing the pole to the off side of the road, necessitating a certain amount of strength, with constant pressure on the

near rein; in fact, it was driving one horse—the near one and letting the other horse trot on. Now to bring the pair together and make them easy to drive was the work of a few moments. First, I buckled the near horse's rein in the middle bar, shortened his coupling rein three holes, tightened the curb a little, and left the off horse in the cheek ring; let out the near outside trace one hole longer than the other and tightened the pole piece one hole shorter, so that if the near horse had been pulling the phaeton by himself it would go straight; then handed the reins to the lady, and we drove on. After going some distance I asked her how they drove, and she answered: "Splendid; in fact, they drive like one horse, as they should have done at first."

As we seldom get two horses of the same disposition—action, gait or temper—we should find out the faults of either and try in a practical way to remedy them.

While upon this subject of pair horse driving I must call my readers' attention to the most important part of the harness—the reins. Any one who drives a pair knows that the coupling rein (inner rein) has a buckle, which buckles on the outside rein (draft rein), but how few know or ever give it a thought what that buckle is for, and why so many holes are punched. I have seen reins that have been used for several years and used on

many different pairs of horses which, from the appearance of the working holes, were never altered since they were new. Now, we might have a pair of horses equal as to height and everything which goes to make a nice match; but supposing one should have a short neck and the other a long one, how are we going to get them to drive handy unless we have the reins so that each horse shall each have an equal share of them? One coupling rein might have to be six, or even nine holes shorter or longer than the other, as the case might be. Take for instance two horses which shall be exactly alike in height and length. One horse might bend his neck a little more than the other, consequently bringing the nose a little nearer the chest, making two or three holes shorter in the coupling rein necessary to bring it to the proper position. Coachmen who use bearing reins have less trouble in bringing their horses together than those who eschew them. All coach horses that are used for heavy carriages in town, such as landaus, D'Orsays or eight-spring Victorias, look better and drive easier with them.

Cobs and ponies look as well without them, having shorter and stiffer necks. Therefore, there is really no utility in using them. Bearing reins, like other parts of harness, should not be used as fashion dictates, but as necessity requires. Driving a journey without bear-

ing reins is decidedly a relief to most horses, but I strongly recommend coachmen who drive big horses in town to use them. They will find it much easier for themselves. There is no possible reason that, because a pony looks well without them, a horse should also. There is a vast difference in the use that each animal is put to. It became fashionable some years since to dock ponies' tails very short and hogg their manes; but how absurd to do the same with their big brother, the horse. I remember once a few years since attending a sale at the American Horse Exchange. There were a number of horses, ranging from 15 1-2 to 16 hands. They had previously been bought by a gentleman dealer as an experiment and were advertised as having undergone a special preparation, were all supposed to be in high condition, well broken to harness and docked and trimmed, fit to go into immediate work. According to my idea, however, they were just fit to be turned out for a few months until their tails grew. They were not only docked too short, but their tails, being cut as close to the dock as they could be, were trimmed up each side, giving them the appearance of a worn-out shaving brush. Horses' tails should be cut according to their size and height, and left as square as possible. In fact, carriage horses 16 hands and over should have their tails reach within a few inches of their hocks. Particu-

lar attention should also be given to the way in which they are carried by getting the cruppers stuffed, and of a thickness so as to prevent their lying too close to the buttocks. The manes should also be pulled in proper proportion.

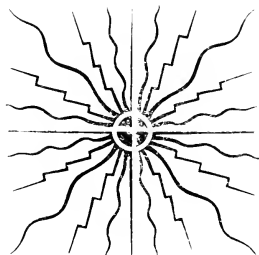

THE WHIP.

Knowing how to use the whip is of much more importance than some people imagine. There is really no art in being able to catch a double thong; it is merely a knack, and can be easily acquired. I would, however, advise those of my readers who wish to learn to take a lesson from some one competent to teach. Practice until you get perfect. To be able to use the whip is as essential as being able to use the reins correctly. What on earth would we think of a carpenter if he did not know how to use a saw. No matter how well you can drive or how complete your turn-out, a whip with a thong dangling all over the stick gives it an untidy appearance besides adding to the discomfiture of the persons riding with you. The thong when allowed to hang down will catch around the hub of the wheel, and unless you pull up quickly will wind around until you have to let go of the whip altogether. The idea of a coachman not being able to use a whip recalls to my mind an incident which occurred in Boston. I was engaged teaching a gentleman to drive a team. Being an apt pupil, he learned very quickly, and became an

adept with the whip. He was in want of a coachman, and had requested the representative of the leading coach builders at that time, who had an agency in Newport, to send him a first-class, practical man. Now it so happened that the representative of this firm was at that time a very young man, in fact, quite a novice at the business, and possibly more interested in cigarette smoking than four-in-hand driving. But he sent one; I don't know where he found him, but he came to Boston and presented himself as the coachman recommended very highly by the carriage firm. I never before or since beheld such a specimen of a private servant. Over six feet in height, and of slovenly appearance; in fact, he looked more like a farm hand. I was asked my opinion about him as to his being suitable for the place, and found myself in a very embarrassing position. It is against my natural inclination to injure anyone or prevent their obtaining a livelihood, so I merely made a proposition that if he could drive a team he could certainly handle a whip. He was asked the question. "Oh, yes," replied he; "as good as anybody." A team whip was handed to him made by one of the crack London whip makers. He looked at it, threw out the thong, and tried ineffectually as he termed it, "to crack it," but it would not go off. He put it down with the remark, "That

ain't the kind I've been used to," and I know he spoke the truth. He was saved the trouble of becoming very familiar with it by having his return car fare paid to Newport.

There are certainly a good many coachmen who never aspire to drive more than one or a pair, who are sadly deficient in knowing how to hit a horse without breaking the whip. There is sometimes an excuse for breaking the thong, as it may become rotten through having been exposed to wet or the constant use of pipe clay, which is sometimes used to keep the thong white. The stock is often broken through a flaw in the wood or unavoidable accidents, but in most cases it is broken by hitting the horse with the stick instead of with the thong, which is intended for that purpose only. Coachmen who cannot hit a horse effectively with a light whip and without being obliged to have the top half whalebone should never be allowed to use one, a bale stick or plough handle would suit them better.

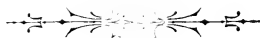

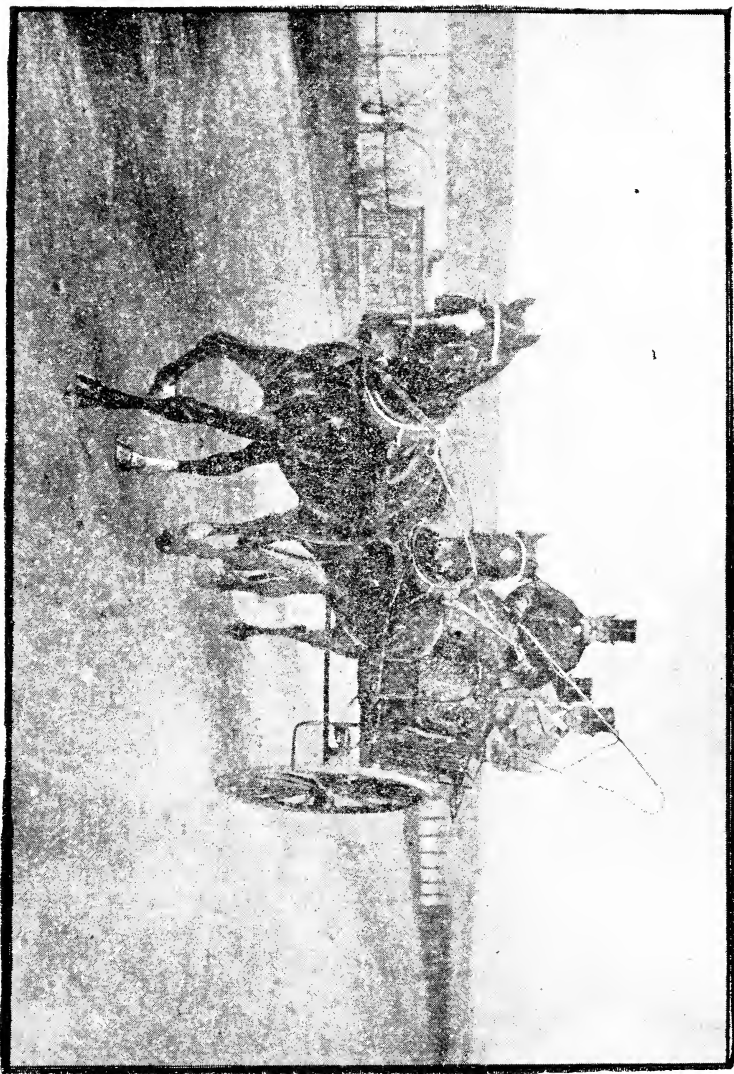

TANDEM: MR. BURTON MANSFIELD.

(FROM AN INSTANTANEOUS PHOTO.)



THE TANDEM.

“Oh, what delight a tandem ride,
A high wheel cart with three inside;
The wheeler steady, and leader free,
If the whip is clever it goes merrily.”

I have oftentimes heard the remark, “It is harder to drive tandem than four,” and have repeatedly been asked by gentlemen who drive tandem my opinion upon the subject. Driving tandem or four are similar only in regard to holding the reins. Two horses under equal conditions cannot possibly be as hard to manage as four. There is a great difference between a coach and a cart, without taking into consideration the difference in weight when each is loaded. I know several gentlemen who drive tandem well who could not drive four, but I have yet to find a good four-horse coachman who cannot drive tandem. I have on several occasions seen gentlemen make turns with a tandem that to do the same with a coach would turn it over. With tandem there is no danger of a leader kicking over the bars or a wheeler getting a leg across the pole; neither is there three tons of weight to steady down hills or a brake to be applied every now and then, besides the responsibility of having perhaps a dozen valuable lives entrusted to your care

What makes driving tandem so distressing to many is the absurd manner in which the outfit is put together, neither taste, appointments nor the general principles which constitute a tandem being considered. In some cases, even when the turn-out is complete as to the size of the horse, make of the harness, and cart of correct pattern, there is an utter lack of knowledge how these are to be brought together so that every strap is in its right place, the cart balanced perfectly, so that it will ride easily and comfortably, the horses bitted and reined so that they work like one. Unless these points are considered worth knowing something about, it is almost useless to attempt to learn how to drive tandem. A clock will not go correctly if it is not put together properly and an ill-fitting tandem will make a fool even of a good coachman. The tandem illustrated in the foregoing page is that of Mr. Burton Mansfield, to whom I believe is accorded the distinction of being the first exponent of driving tandem as it should be done in New York. He is a professor on the subject, and has done more than any other one person to assist beginners in acquiring this style of driving. He was one of the original founders of the Tandem Club, which includes among its members T. Suffern Tailer, Esq., whose artistic abilities as a whip were deservedly noticed at the last horse show at the Madison Square

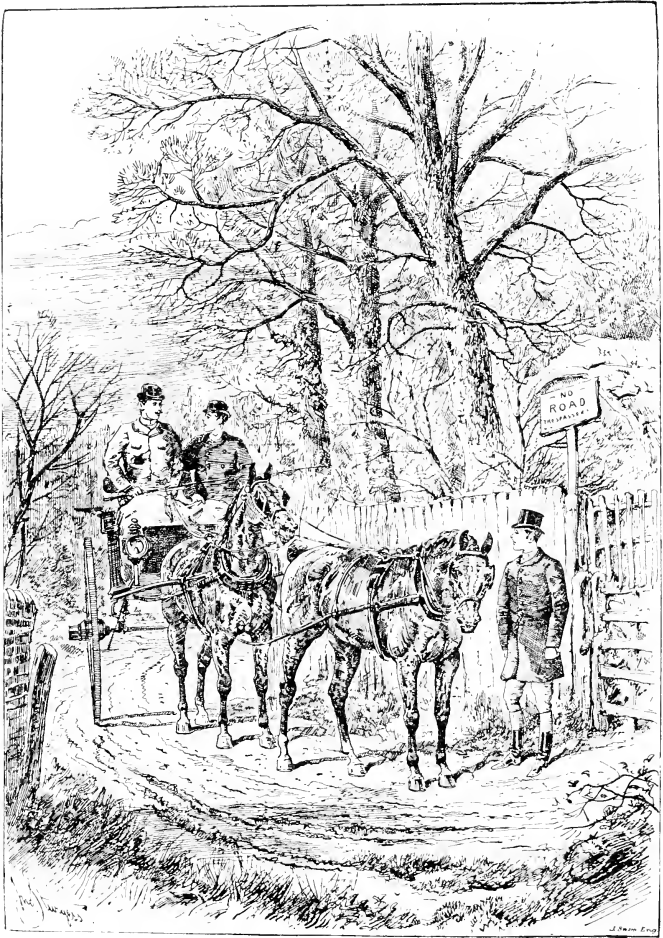

NO THOROUGHFARE.

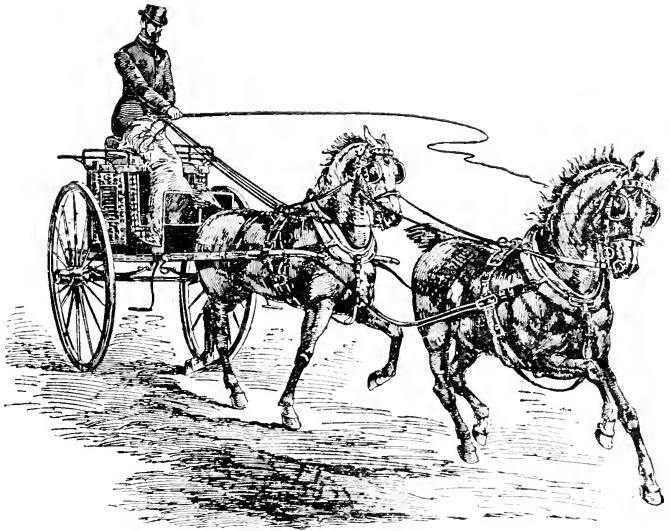

SHOWING OFF.

Garden. As far back as 1867 Mr. Burton Mansfield imported a Whitechapel cart from Peters of London, which has long been recognized as the best model of cart for tandem, and from which model most of the carts in use at the present time have been designed.

Tandem harness should be made to fit properly, every part proportionate as to size; the reins of the best quality of pliable leather and not nearly so wide as those of other harness, which will be appreciated by coachmen who drive with their hands and not as some do, with their elbows. The mention of reins brings to my mind a point I omitted when comparing the driving of tandem and four. I must admit that in the former it is not so easy to finger the reins, as they lay much closer together, coming up almost straight from the wheel pad terrets, whereas with four-in-hand, they are separated to a much greater extent.

Hoses intended for tandem work need not be closely matched as to size unless they are also required to be used in double harness, when of course they should look alike, step and go well together. To those who intend purchasing, I would advise them to have the shaft horse fully fifteen hands, three inches, with large and deep body, showing substance and quality combined, one that will fill the shafts, with large, broad, round quarters, short back, long neck well set on to good

slanting shoulders. On the proper conformation of a horse intended for this work a great part of the ease and comfort of the driver depends. A horse that steps sharp and does not go too far off the ground is by far the best. The leader need not be quite so heavily built, about fifteen hands three inches or nearly so, of good disposition. Be careful to avoid buying one that shies or pulls; a stubborn or stumbling one is equally bad. The leader is no doubt the leading actor, but it does not necessarily follow that he should be a star (gazer) or one that carries his head too high. When putting to be sure to have the wheeler harnessed so that everything fits comfortably. Keep him as close to his work as possible without causing anything to touch him behind when going down hill. See the shaft stops are in their proper place and the back-band loose enough to give the tugs room to play. Have the tugs in the right position on the back-band, so that the shafts are not brought too high or too low to get their level and balance. The cart should set up high enough off the ground so that when balanced the shafts will ride above the traces.

SLEIGH TÁNDEM.



HOW TO DRIVE TANDEM AND FOUR.

The first thing to do before starting out is to see that everything is all right, that the bits drop in the proper place in the horse's mouths and that the curbs are slightly loose. Stand at the off side of the wheeler, take the

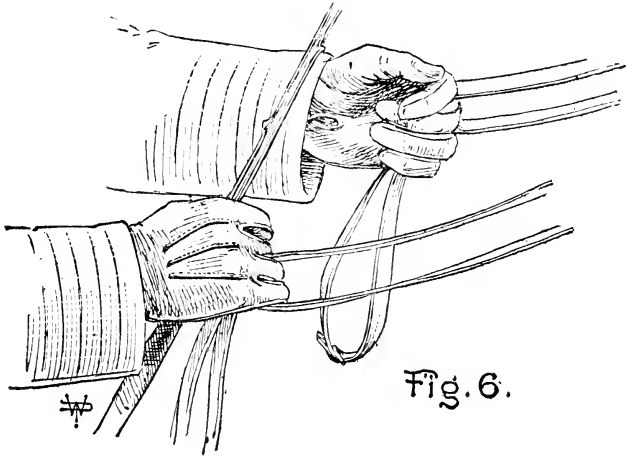

Fig. 6.

lead reins in the right hand, the near rein on top. Place the wheel reins in the left hand, one each side of the second finger, the near rein on top between and under the top finger, the off rein under and between the second and third fingers (fig. 6). Keep the top finger open and

straight and slip the lead reins from the right hand into the left, the near rein on top, the off under the first or

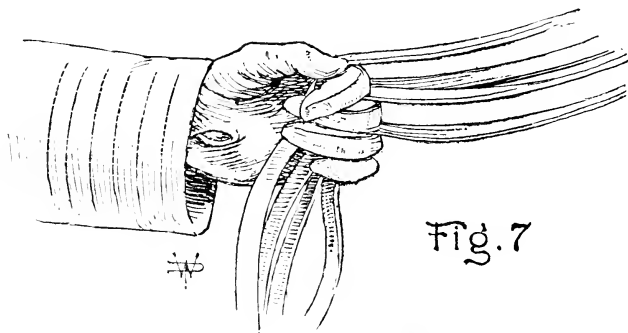

Fig. 7

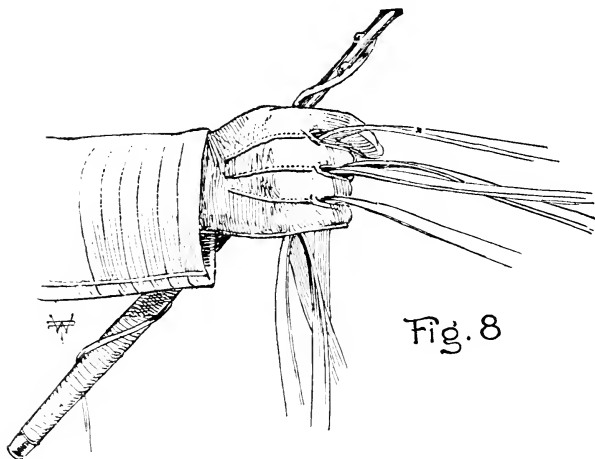

Fig. 8

top finger, and you will find them in the proper position (fig. 7), near lead on top with two reins lying to-

gether, the near wheel and off lead, which is also above the near wheel and the off wheel, between the second and third fingers. Stand back a little to get the necessary length of rein so that when you are on the box they will be as near as possible the requisite length. It is well when driving and the horses at work to notice the distance of the hands from where the reins are joined together—the splice—if team harness the buckles will act as a guide,

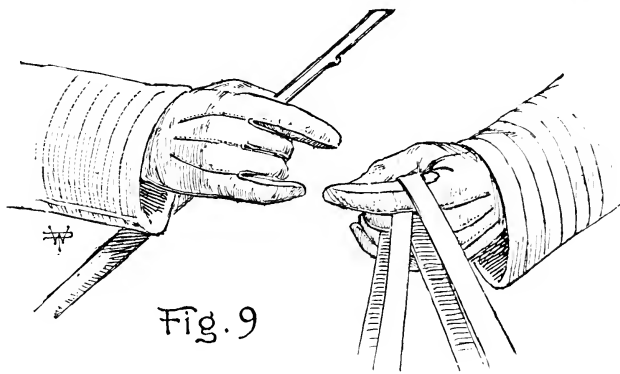

Fig. 9

so that when taking the reins in hand and before starting the same position can be guessed at within a few inches. Now place them in the right hand altogether, keeping them in the same position (fig. 8), thus leaving your left hand unincumbered, and which will be necessary to use when taking your position on the box seat. As soon as seated place the reins in the left hand again and sit and hold the reins as in (fig. 9). It is ne-

cessary before starting off to see that the horses are well up in their traces, and that each rein is in its proper place, neither tight nor slack. Many vexatious delays are caused through starting off with one rein loose for as the horses get into their collars and feel a check on which ever side of the bit the rein is tightest, naturally turn, and with an amateur coachman, who is

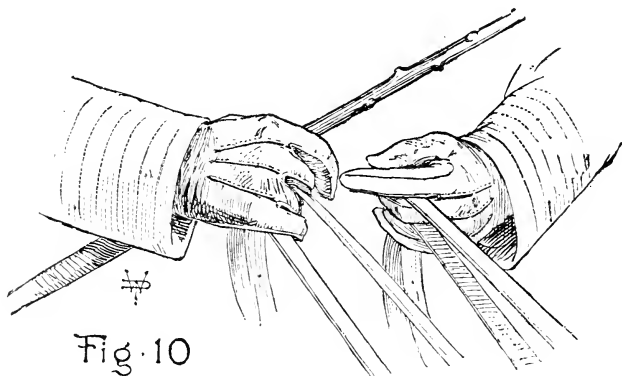

Fig. 10

generally a little nervous at the commencement, might get him into difficulties. After a little practice with the reins the best and most coachmanlike way is to take the two wheel reins in the middle finger, get the required length, just enough to feel the horse's mouth lightly, keeping the lead reins between the two bottom fingers of the right hand, thus (fig. 10). Having the length of rein, so that they are perfectly even on each side, and

then as the horses start off and the leaders fill their traces drop the lead reins in their proper position. By doing this each horse will have its fair length of rein. Now we will suppose you have started off all right, not forgetting to drop your hand a little when giving the horses the signal to start, and wish to make a short turn

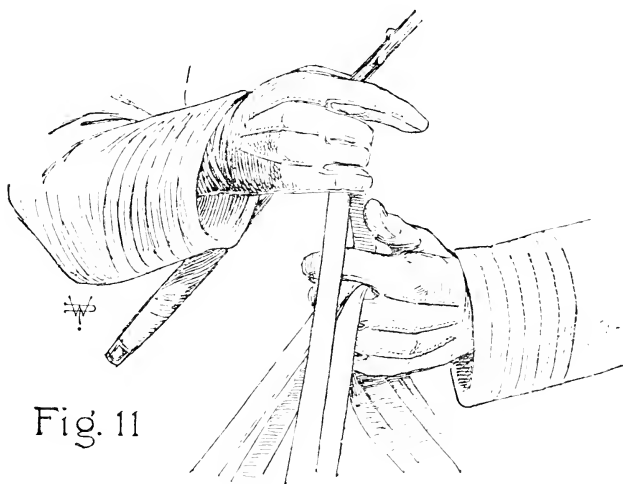

Fig. 11

to the left, for instance, going around a corner, shorten the near lead rein, which is easily accomplished by taking hold a few inches below the left hand with the bottom part of the right hand, thus (fig. 11), at the same time drawing it towards you over the left hand which should be pushed forward at the same time till it forms

a loop (fig. 12), then press the thumb down tight to hold it firm till the turn is made and the horse wants his head. Raise the thumb, the rein will run straight again. Whilst doing this have the right hand ready on the off rein to prevent, if necessary, the wheeler turning short. When making a turn to the right the off lead rein is looped and

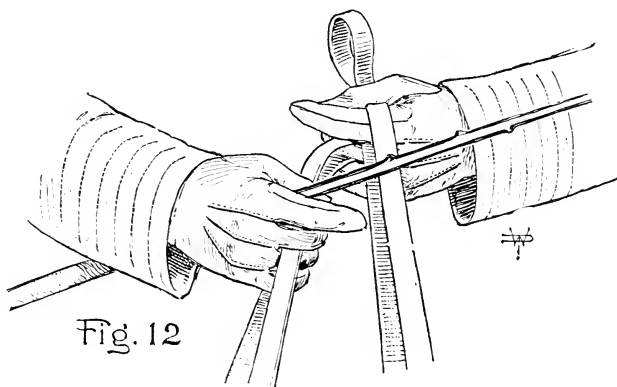
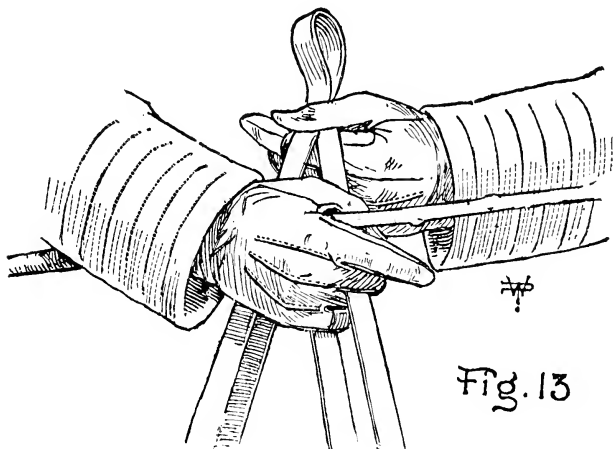

Fig. 12

the right hand is at liberty and at the same time ready to catch hold of the near reins (fig. 13). When merely pulling to the near or off side of the road to avoid obstacles or passing a vehicle, a slight touch of the right hand on the lead rein will be all that is necessary, keeping the right hand on the rein until the obstacle is passed. It might perhaps be necessary to turn the wheeler off as well if he does not follow, which can be done by tak-

ing hold of the two reins at the same time while pulling to near side (fig. 14), and taking hold of the reins as in (fig. 15), when pulling to off side, but always bear in mind one thing—never to separate the rein or allow them to slip between the fingers; it is much better to practice with reins that have been in use for a considerable time, they



are more pliable, softer, and not so likely to slip. Never attempt to turn short without having the leader well in hand. Should he happen to be a free goer and the traces taunt he will pull the wheeler around too quick and perhaps throw him down. Going down hill the lead reins should be shortened so that the lead traces

are absolutely slack. Every ounce the leader pulls going down hill means a pound more for the wheeler to

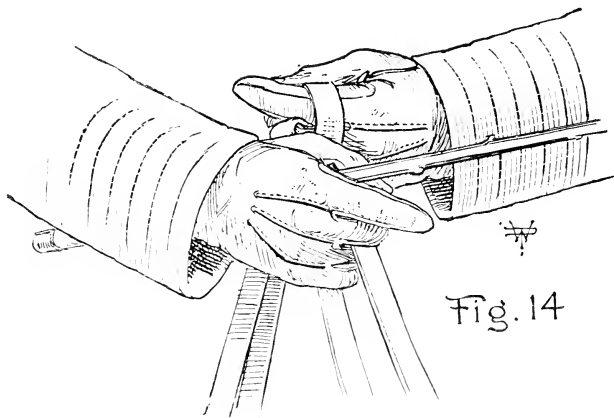

Fig. 14

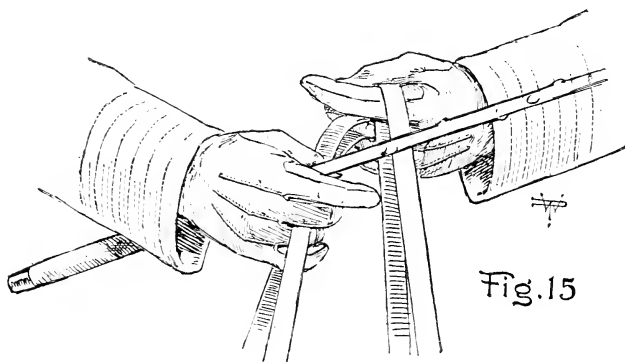
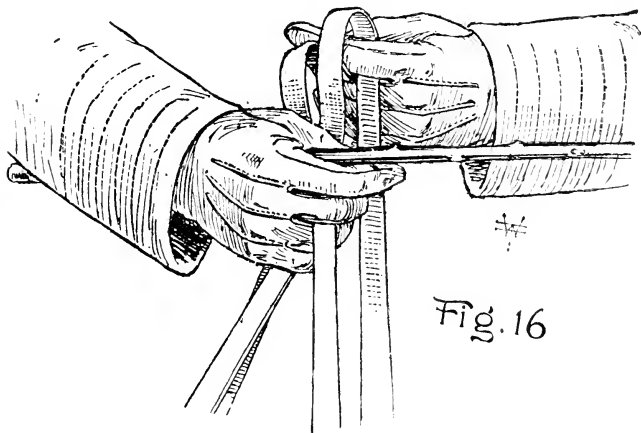

Fig. 15

hold back. If a short hill it will be sufficient to take the lead reins in the right hand (without separating them)

and pull them towards you (fig. 16), and "steady the leaders," but it is not safe having the right hand so engaged for too long a time. It would be very awkward to the driver if the leader should stumble or a sudden turn to either side of the road be necessary. The best way to take the lead reins up when coming to the brow



of a hill or before making a short turn is to take the lead reins from the left hand with the two bottom fingers of the right hand (fig. 17), pull towards you, at the same time push the left forward (fig. 18), and place the lead reins in the left hand again, in their former position excepting the lead reins are shorter. If you find it necessary to take the wheeler back a little take the lead

reins in the right hand, with the thumb and top finger grasp the wheel reins from behind the left hand, at the same time pushing the left hand forward (fig. 19), until the necessary amount has been taken up, but keep the fingers closed so that the reins cannot escape, then drop

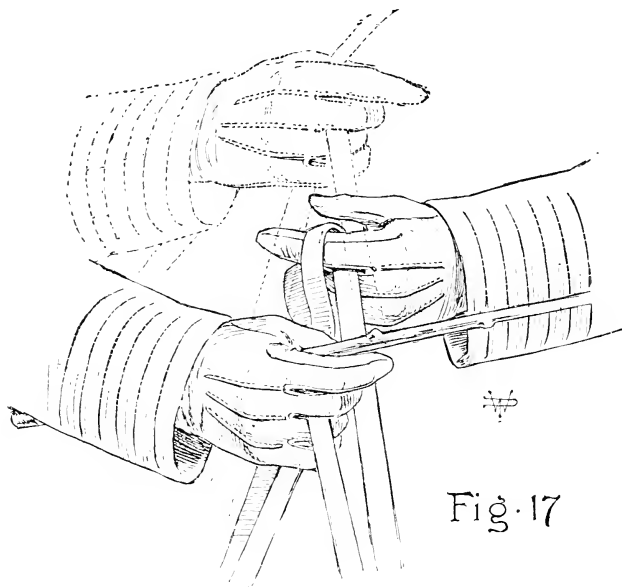

the lead reins in their former position. This method gives the driver a better chance to feel the mouths of his horses and get the exact length of rein than by taking hold of the reins with the right hand and pulling them through the fingers from behind the left hand, which

should not be done, unless you find it necessary to shorten all the reins at once.

Driving a team is very similar to Tandem, both as regards the position of the reins in the hand, excepting when taking them in hand to start, when having the reins in the left hand, as in fig. 7, and before

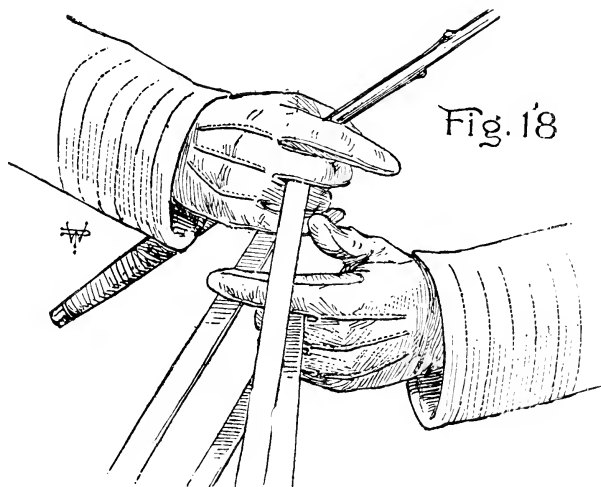

putting them into the right. With the right hand then take hold of the two off-reins and pull them out (fig. 20) until the length from the buckles on the wheel reins to the hand are of equal distance, this will leave them hanging loose, whilst the two near reins are taut, but when they are put into the right hand and you have be-

come seated on the box and the reins are then put into the left hand, you will find that they are perfectly even.

I must now take the liberty to give my young readers some words of advice. Don't think for one moment that when you have learned to hold your reins, make turns and come home safe after your first drive that

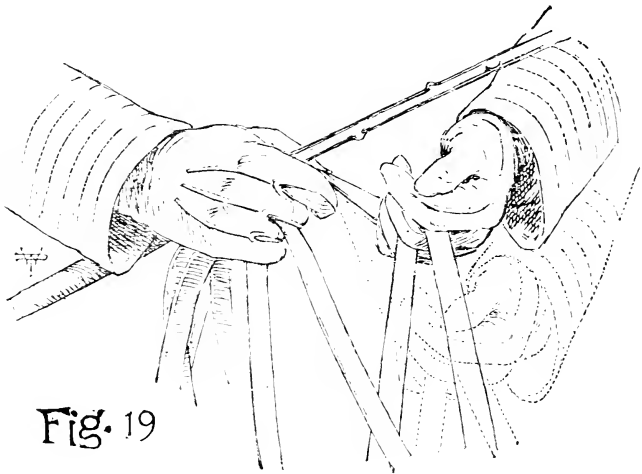
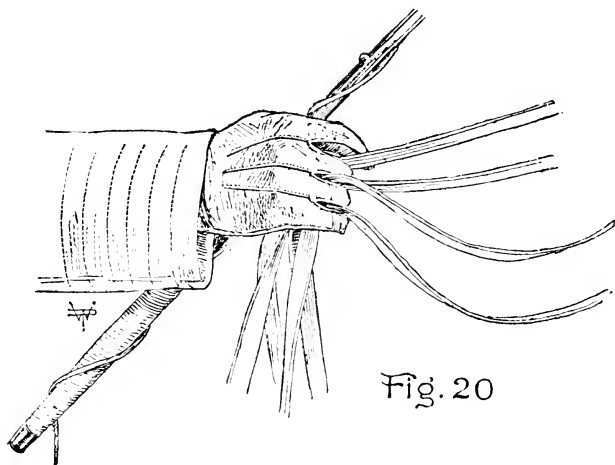

Fig. 19

you have no more to learn. I will say for myself that I have been driving all descriptions of vehicles for the last twenty years, and every time I go out I can generally find some little obstacle in my way that I have never encountered before which requires some new move on my part to surmount. I admit that it is easy (when you

know how) to guide a tandem or team through Central Park, when not too crowded, or down country lanes and highways, but to be always ready in cases of emergency, having everything as it ought to be, every strap to fit and in the right place, and last but



not least having your horses in perfect command and each doing only its proper share of the work requires more practice and judgment than most people would credit. There is no enjoyment or pleasure in driving to those who make hard work of it.

FOUR IN HAND.

To those of my readers who drive or intend to drive a team I most humbly apologize for giving them a "back seat." It was my intention when "starting off" to give all those interested or desirous of becoming interested in coaching a "front seat" in this, my "first trip" on the "literary road." But upon further consideration I deemed it advisable, being a "new beginner," to start at the bottom of the hill and gradually ascend, fearing if I started at the top I might come down too quick, and, in the event of not being able to "put on the brake," cause a "spill," and thus bring to an abrupt end my first venture.

Having got so far on the road I think it is about time I came to the first "change." I know from a long and varied experience amongst all classes of horsemen that it will be harder for me to make those who have been driving a team for some time to alter their method than it will be to teach those who are about to start one.

There are several gentlemen who have driven teams for years, and who are considered first-class whips, their names being, commonly speaking, household words in



· WALTER PETTEE ·

A PROFESSIONAL.

society, who are woefully ignorant of the different alterations required at times to make a team go well together. Nine times out of ten the owner of a team drives himself; that is what he keeps it for—his own pleasure and amusement. In fact, in most cases, drives it from the stable himself and back there again, the coachman being incompetent to drive four. Now, it stands to reason that if a man cannot drive a team we can hardly expect him to know when he has put them to whether he has put them to as they should be. Therefore, the person who drives them should, for his own comfort and safety, be able at once to see and rectify any imperfections that may be in the biting, reining and working of the horses; but when a gentleman employs a practical coachman, one who really does understand his business, and drives them himself occasionally, it will be sufficient for him to be able to drive, as the team will be put together properly. To have a team put together and know how to drive them in a coachmanlike style requires a good deal of practice; more so, in fact, than most gentlemen who keep teams imagine.

I have on different occasions, while engaged in driving a road coach, been asked by passengers to allow them to drive a little, and, providing I had a quiet team, with plenty of time and a straight, easy piece of road to go

over, have oftentimes allowed them to "hold the reins," and I never came across but one (and that was a lady) who did not think it was "quite easy," and so it was. They would find it quite easy to hold the helm of a sailing vessel under certain conditions—fine weather and a straight run—but would find it much more difficult in a gale of wind. Allowing passengers to drive recalls to my mind an incident that happened last season. I was on the road home, and when within a mile of the town was asked by a gentleman passenger to allow him to drive. I did so. The road was perfectly straight with the exception of one turn which we got around safely. The new coachman became quite elated with his driving, and begged of me to allow him to finish the journey as he wished his friends whom he expected to be on the verandah of the hotel to see him in all his glory pull up. I consented, with the admonition that before reaching the hotel he should steady them a little, and at the same time explaining the difficulty he would find in trying to stop nearly three tons of weight on a down grade. When we got within view of our stopping place instead of steadying his horses he wanted to go faster and clicked to the horses to urge them on. I begged of him to commence pulling up, but it was no use. He could see his friends and other guests of the place who were waiting the arrival of the coach and renewed

his efforts to make them go on. The consequence was he went right past the hotel, with his hands right up parallel with his chin and stopped them unceremoniously at the next hotel, some 40 yards beyond our stopping point, and if he had been on the box by himself I don't think he would have stopped yet. This is a case of "too easy." There are, I am sorry to say, a good many more like him who think because they hold the reins—not drive—over a team a short distance on a straight road imagine they are perfect coachmen, and that the faster they go the more they think they know. Unless you are an experienced driver it is not only dangerous but foolhardy to drive fast, by so doing you run into danger quicker, and if in danger have less time to extricate yourself. Coach horses should never be extended or be at the top of their speed, if they are they soon tire. Some people think that because they are riding behind four horses they ought to go further and faster than with one or two. They do not take into consideration the weight that those four horses have to pull, even a break with eight passengers will weigh thirty hundred pounds, or 750 pounds to each horse. Another important thing, and one very seldom thought of, a horse whose natural gait is say 10 miles an hour, you can drive him 30 miles a day by going slow, say seven miles an hour, but to drive him at his top speed

will tire him out the first hour. As it is seldom we get two horses gaited alike how can we expect to get four and with the same amount of speed? We will suppose that three out of the four horses can go 10 miles an hour with ease and the fourth horse eight miles an hour. Now, if we drive nine miles the first hour the slow horse is going or properly speaking being pulled along a mile an hour faster than what he is really capable of doing easily, consequently to do that extra mile in the hour he could not do any work, therefore the other three horses must do his work for him, making it harder for them and helping to tire them out, and the slow horse is completely done up. Now, if we had gone only seven miles an hour, all four horses would be doing their equal share of the work (always provided they were properly put too and driven) and going within themselves, doing less than what they were really capable of doing. They would finish fresh and be ready to go another seven miles, and if in moderate condition, repeat the undertaking.

I shall never forget a scene I witnessed two years ago. A gentleman arrived late one evening at the hotel stables with a four-in-hand break. He was accompanied by two gentlemen friends and a coachman. They looked tired and appeared to be in distress. From a conversation I had with the coachman, it seems that they had

started from New York a few days previously for a coaching trip through the country and were en route for Saratoga. When two days on the road one of the leaders dropped dead, as the coachman expressed it, "through doing all the work." They bought one from a farmer to take his place, which turned out to be very lazy, and would do no work, and in trying to hit him with the whip, broke it. From that time out the lazy horse would do no work and his mate commenced to get tired, went off his feed and became sick. They decided to stay over two or three days and rest the team. A few days later they got ready to start and were harnessed up in the yard. The wheelers were very evenly matched, but the leaders, one was a thick-set mare with no ambition, in fact, looked too slow for a coal cart; the other a good-looking gray, full of courage. I really felt for him. I could see the reins were even and both bitted the same. The reins in the cheek ring just suited the mare, but would not prevent the gray from doing all the work, if he so desired, and his looks betokened him a good one. I was hoping they would give me a chance to speak to them so I could offer a little assistance and advise them to buckle the gray down and take up his reins a few holes. I did speak to the coachman about it, but he did not seem to understand, and a few moments later they started off, with

the gray about half a yard in front of the other leader. Nearly a week elapsed when I met a friend of mine who had driven over from Saratoga, and I asked him if he had seen or heard anything about the four-in-hand. Yes, he replied there was a party arrived in Saratoga the day before I left driving a break and three horses, and I heard it reported that he had lost his best horse on the road—a gray one—who had dropped dead. The party were all sick and disgusted with their trip and intended to finish their journey by train. It was just as I expected. I am at a loss to understand why persons are so foolhardy as to start out on a trip with four horses put together by chance, not knowing the relative merits of each horse, or what the amount of work he is capable of doing, or has to do, besides being ignorant of the distance a horse can travel without tiring.

I was once employed by a gentleman who had spent no end of time and patience, in getting together four very good goers, and few men could hold them together better than he could. We were out on the road and he overtook a friend also driving his team, who piqued himself on having fast ones. They had a few minutes' chat, when to the latter gentleman's perfect astonishment, my employer went away from him and the supposed fast ones with perfect ease. We met an hour afterwards in the park, and when they had come side by side, the same

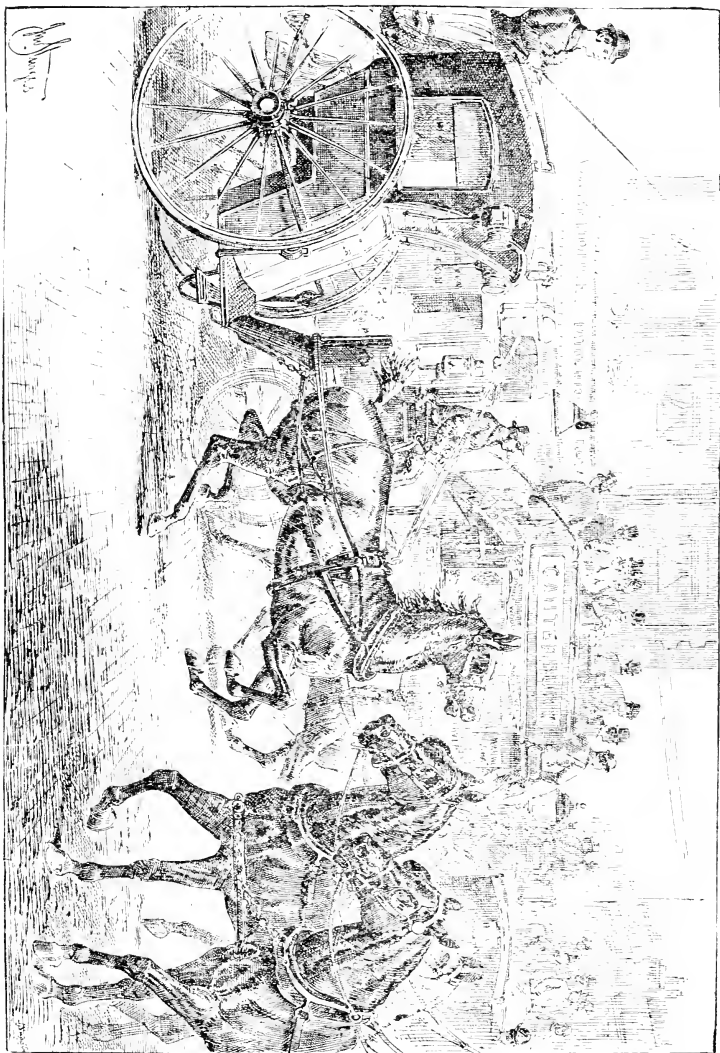

ABOVE HIS BUSINESS.

result took place. It ended in a deal, and they actually exchanged teams, my employer getting a large sum of money in the exchange. We went out with our new team every day, getting them properly bitted, in road language, putting them together. The fact was, three of these horses were beyond comparison, much faster than our former team, but the fourth could neither step nor go with the others. This horse we sold and put in one fully as fast as the others. They were then one of the fastest teams in London, and could step together like soldiers; whereas before, they only seemed to have been put together to be in each other's way. A short time elapsed before meeting again, when the tables were completely turned. We were going through the park when a team came by us at a good pace, and instantly recognizing them as those we had exchanged, my employer permitted them to get a few lengths in advance, then put on the steam, caught him, and passed at a good fifteen miles an hour. Had "Tam O'Shanter" on the gray mare, or Scott the "Jock," mounted on the ghost of Pegasus passed, he would have been surprised, but his surprise would have been tame compared with his perfect astonishment at the matchless style of going and the pace of his former bays, but so it was—he was beaten, and that by his own horses. True, one had been changed, but this he did not know. The horse, taken out of the team,

was a fair goer, but had no harness action, but after being ridden a few times, made a splendid hack. Now, here was a young horse being sacrificed, and spoiling his companions, from being put into his wrong place. So much for judgment, or rather the want of it. Judgment in horses certainly is not possessed by one man in a hundred who keeps and uses them, and yet scarcely one man in that hundred will allow or believe he does not possess it.

To those who like coaching and intend taking a trip, I strongly recommend them before attempting to start out, to get some one well qualified to judge the right sort of horse most suitable for the work, and what is more important, to see that the team work well together and are properly put to, so that each horse has the proper length of trace, pole chains, and the reins adjusted so that when the team is at work each horse will do his even share and no more. There is, moreover, a good deal of judgment required on the part of the driver when on the road. Some men will drive ten miles a day more than another and keep their teams fresher and in better condition. Travelling over rough, hilly roads makes the work for the wheelers harder than when driving along a smooth road. On going down inclines the leaders ought to be kept back to give them a chance to rest themselves. The wheelers, if the brake is on and holds

good, have a certain amount of work to keep the pole straight—in fact, the wheelers are always kept busy. It is, therefore, advisable when going up hill to let the leaders do their own share and a little more. I remember once travelling by a coach and observing the two wheel horses, both fine looking powerful grays, that the near horse had not once tightened his traces for upwards of two miles, and on my saying “I suppose he was making up his mind as to when he should set to work” the coachman laughed and said “his time is very near up now, sir.” He said true enough. In another half-mile I saw a hill before us. A couple of hundred yards before we came to it the gray horse sprang into a gallop and the others joined, and this horse certainly took half the coach to the very top of the hill. The remainder of the stage was all against collar and the gray never wanted a word said to him the whole way, in fact he was a horse and a half until we changed, and his comrade about one-fourth of one. I am ready to allow that those two wheelers were not such as a man of fortune would select for his team, but in their place they were both good ones.

In riding on a box sometimes if a man is one of the sort—I should call him one of the right sort—he may probably see one or more of the team merely carrying the harness. He must not infer because the

driver permits them to do this for two or three miles that the coachman is a bad one or careless. No man can judge of the propriety of his doing so as well as himself. Some horses like to do all the work at first, others at the end of the stage, and in this they must be indulged or they are good for nothing, or would be rendered so. There are horses which never want a touch of the whip over anything like level ground, but are bits of rogues at steep hills. They therefore do their share on the whole, and where they punished to make them work uphill they would perhaps jib and not draw an ounce, probably commence kicking into the bargain. Others, particularly if not quite so fast as their comrades take very little of the load on the flat, but at hills will take half the coach up. This is their forte, and for this their exertions must be reserved. Some for the first five miles are hasty, and do more than their share, consequently to a certain degree become exhausted and work but little for the remainder of the stage. Others only set to work when—in a road phrase—“they smell home.” Then they peg away and pull your arms off unless you let them take half the coach. Letting horses have their heads, i. e., driving with a loose rein, gives the free ones a chance to do more than their proper share of the work, therefore they get tired sooner. Keeping your horses in hand

and together is of the utmost importance whether driving through a park, country highway or busy city streets, you never can tell the moment something will get in your way. A person might inadvertently attempt to cross the road; a child may stray off the sidewalk; or in driving through the country cattle might cross your path. Every one is liable to cause an accident if the reins are loose, because it requires more length of pull to enable you to feel the horse's mouth, and as generally happens to young coachmen who are taken by surprise they forget at the moment what to do—to shorten their reins.

Most of the foregoing faults arise by gentlemen taking lessons from what a stage coachman would call "park coachmen." I have repeatedly been out with gentlemen in this city who have taken lessons by the dozen. They know how to hold the reins properly and how to make a turn, providing the team is going moderately well; but when it comes to any practical work—driving over rough roads with a coach loaded and lots of other important points which is most important a coachman should know something of, they are entirely ignorant. It is a well-known fact to nearly all those of my readers who have had any experience in coaching that to become a proficient whip requires a lot of practice and constant driving which can be more

easily acquired by driving out with friends who own coaches, and if practicable take every convenient opportunity to sit on the box seat of a road coach driven by a professional. You will learn more in one journey than a park coachman could learn you in twenty lessons.

It is much to be regretted that there are so few opportunities in New York to take the foregoing advice. There is certainly one great drawback—bad roads—especially in this State. There are no people in the world so fond of driving as the Americans, and I must confess there are no people so heavily handicapped in this most favorite and healthy amusement. Excepting Central Park and a few avenues, the roads are abominable, I shall never forget (nor forgive the street commissioners) for the torture I and party suffered through being so reckless as to attempt to reach the race-course at Sheepshead Bay with a four-in-hand drag, going by way of Broadway and South Ferry. Having to make a stop at Delmonico's in Broad street necessitated our taking that road. The slow progress and frequent stoppages of the vehicular traffic in New York is certainly occasioned by the uneven paving of the roads, and conduce more than any other thing to make slovenly drivers. Broadway is certainly improved since the stages were taken off, and unless they make some rules to govern the city traffic the sooner the

stages are taken off Fifth avenue the better it will be for the driving public. Take, for instance, Fifth avenue any afternoon during the season. There are strings of vehicles of every description. The private carriages of course predominate. Four lines (not as they ought to be on a straight road) trotting along, but at almost all times what a London cabby would call "a full stretch walk." And I have no doubt there is not one person in a hundred of the driving public that has the slightest conception of what causes it. The men themselves who drive stages don't know they are at fault. There being no bye-laws of the city ordinance to compel them to pull into the off side or near side, according to the way in which they are going, when pulling up to set down or take up passengers, consequently they pull up as they would on a plain or desert—sharp and in their tracks—never for one moment thinking or caring what is following behind or whether that which is behind has sufficient room to pass, which it frequently happens there is not. The consequence is that the vehicle following has to pull up short, and everything behind, for perhaps a block, has to do likewise. If the stage driver was compelled to pull to the side of the road before coming to a full stop the driver of the vehicle following would know what the stage driver intended to do, and instead of pulling up himself and

stopping the traffic would pull to the near side (middle of the road, and go on. It is wrong at any time to pass between a vehicle and the curbstone or sidewalk, as some do. There should be but one way to pass each other when going the same way, and that the right way.

It is a positive fact that a good coachman can drive with more ease to himself in London than in New York, although the traffic is greater, the streets narrower, and in a good many instances have short and awkward turns. There he has only to look out for himself. So long as he is doing what is right and proper he knows that every other driver will try and do the same.

It was in the year 1880 that one of the best known gentleman whips of England, the Duke of Beaufort, being on a visit here, was invited by the owner of a fast and well-appointed road coach working between New York and New Rochelle to drive a stage. After looking over the coach and complimenting the owner on the way in which it was horsed and turned out, his Grace replied: "I could drive your horses, but I should not know which side of the road to drive on," a conclusion he had come to no doubt from riding on a Fifth avenue stage.

To some extent we must make an excuse for the careless way in which the stages are allowed to dawdle up

and down the principal avenue of this great city. Having no conductors behind makes it very hard on the driver, who cannot be expected to fill both positions requisite to conduct and drive at one and the same time.

I don't know whether the stages try to imitate the coaches or whether the coaches imitate the stages, but it is a fact much to be regretted that neither of these excellent means of conveyance have improved their services. In fact, as regards coaching, they have actually degenerated to a considerable extent in the past ten years. There are more in quantity but a great deal less in quality. Since 1880, when the "Tally-Ho" went off the road, there has been a subscription or Club Coach put on in its place. It was badly managed, badly horsed, and I might say, badly driven when Frederic Bronson Esq., was off the box.

Putting a coach on the road (I mean a public coach) is an undertaking of great responsibility. It means in the first place a large expenditure of money, a good, substantial, well-made and good-running coach, as many sides of harness as horses, and as many horses as miles. Except when working a "half number" going up one day and down the next, when half the number of horses and harness is sufficient.

The horses being the moving power and therefore the mainstay of the success of the enterprise,

great care should be taken to have some responsible person who thoroughly understands the points and conformation that go to make a coach horse, to select and buy them. You must not expect that every horseman understands what constitutes a horse suitable for a coach. It must be borne in mind that the work is sharp and hard while it lasts, necessitating speed, bone and stamina. They should not vary much in size, as it is necessary to change over alternately, as they work much better by doing so and are not so likely to get tricky.

Color is a secondary consideration in a coach horse, always bear in mind the old maxim "a good horse cannot be a bad color." They should not be above 16 hands nor under 15 hands 3 inches, with good, round, smooth hoofs, short pasterns, straight and flat legs, round, lean and bony knees, a long high-reared neck, great towards the breast, which likewise should be large and round; withers sharp and pointed, the back short, even and double chined. The sides and ribs deep, large and bearing out and close shut at the knuckle bone. The rump round and broad, thighs long and large, with well fashioned bones and those well covered with flesh. They should stand primly on their legs, and these placed as legs should be. Lastly, the temper and disposition should be considered, and though there is

scarcely one thing in which people's opinions vary so much, it will be generally found that moderation in respect to spirit is much the best, a runaway and a dull jade being equally uncomfortable. One that will do his work freely and at the same time manifest no eagerness to go on when there is no occasion, is much the best horse for coaching, and should, if possible, always be made choice of. The horses should be purchased at least six weeks before being required, as being young and not used to quick work, they require a good deal of making up. Merely putting them in a stable with perhaps incompetent men to feed, and driving at irregular and unfrequent intervals will not assist in getting horses in the condition necessary to fit them for the work required. There is a difference in the preparation of the race horse and the trotter for their especial work; so there is also for the hunter and the harness horse. The latter, if young and poor in flesh, must in the first place be made up by judicious feeding, good grooming and slow work until they get substance on them. Their work can then be increased a little every day, both in distance and pace.

I remember once seeing a coach start from the Brunswick Hotel on its first trip. The horses had been driven for several weeks by amateur coachmen, bad ones at that, and by their appearance the feeding and groom-

ing of the horses had been entrusted to an amateur horse-keeper. The leaders in their endeavor to start actually pushed each other down; they looked thin, tucked up, and more fit to be turned out for the season than for the work they were engaged in.

A man may be a very good coachman, yet be a very inferior horseman or brakesman; but the latter cannot be fit for his business unless he is a first-rate coachman, and he requires much more than this: He must understand perfectly the habits and tempers of young horses, and indeed of all horses. He must have a clear head, quick apprehension, good temper, great presence of mind, strong nerves, strong but light hands, know every contrivance to thwart the intentions of violent horses and the mode of soothing timid ones. He must be able from habit to judge at once by the manner of a horse what he is likely or preparing to do; in short, to judge what sort of a customer he has to deal with. There is also a great deal of judgment required in putting young horses together, care being taken to match them with due regard as to their way of going, disposition and comfort at work, more especially as they will in all probability be driven by several different gentlemen, who drive for pleasure, and for their ease and the safety of the lives of the passengers intrusted to their care. The breaking and properly putting to-

gether of the teams should be intrusted to an experienced man who really knows his business perfectly and practically.

Mishaps and accidents will sometimes happen through unavoidable circumstances to the most careful and experienced coachman, but where one will happen this way a score will occur through ignorance that might possibly have been avoided if good judgment had been used. As I have already remarked, "a little knowledge is a dangerous thing," and is indeed more so when acquired from those whose want of knowledge in this particular business is their distinguishing characteristic.

I have seen gentlemen start out with a team with the pole pieces drawn so tight that the wheelers were actually carrying the pole on their necks. The most cruel thing I ever remember seeing was at Richfield Springs. A young gentleman who has the name of being a first-class whip pulled up opposite to where I was standing to set down his passengers. There was blood trickling down the near wheel horse's shoulder. I called his attention to it, and was surprised at the reply I received: "Oh, that is nothing. It happens every time I drive him; I think the collars are too tight." And in most cases this is generally considered the cause of sore shoulders, but it is a very erroneous

one. A horse will choke and work uncomfortably with a tight collar, but very seldom gets sore, as it fits too snug. It is the collar being too large and therefore continually working up and down, causing a certain amount of friction; but where a horse is galled and bleeding from the top part of the neck and withers, especially wheelers working in a team, it comes from having the pole pieces too tight. The leaders pull from the pole; therefore, if the pole is not allowed to hang free and entirely without the assistance of the pole pieces, it stands to reason that the leaders must pull on the wheelers' necks.

When putting too, let the pole pieces or chains hang loose. They might appear too slack while the team is standing on a level floor, but when on the road and especially going down hill they will be found tight enough. Alluding to trotting down hills I allow that with a driver that has no hands it is to a certain degree dangerous, but there is danger in most things; but going a fair pace down hill is not so dangerous when a coachman does it as many people imagine. If an accident does happen while doing so the effects may or may not prove more fatal than if it had happened at a slower pace, but of this I am quite satisfied that where one horse falls in going eight miles an hour half a dozen would do so at five. When I use the term "hill" of

course I do not mean a precipice; with a proper brake and good tackle there is really no more danger trotting down hills than on the level road, but with the imitation brakes as adjusted to some of the coaches, they are really of no earthly use except as an ornament to be used occasionally as a step. It is surprising to me that with all the improvements latterly perfected with nearly every class of vehicle that the properly adjusting and finding out how and where the brake ought to be put on a coach so that it will act as it was intended it should, to help to stop the wheels from turning and therefore stop the momentum of the coach almost instaneously if required. There is not one brake in twenty that does so, I will admit, and many accidents have occurred through this. Only last season I was invited to drive out with a gentleman who had started a team and had employed one of the best known firms of carriage builders in this city to build a break regardless of expense. It was certainly a very pretty one, but entirely unsuitable for the purposes for which it was required, to run on a rough, uneven country. The vehicle itself being very short in the reach, in fact too compact, and as it unfortunately happened some time afterwards very easy to turn over. The front seat was made to carry three persons, the driver sitting on the off side as usual, which made the reins come to the hands in a triangular form.

There is certainly no objection to having the front seat made to carry three or even five persons, but why not have the driver's seat in the middle? It would look equally as well, if not better, give the driver more command over his horses, in fact bring him on a straight line and nearer to them. Some persons may say how could the driver apply the brake? But this is very

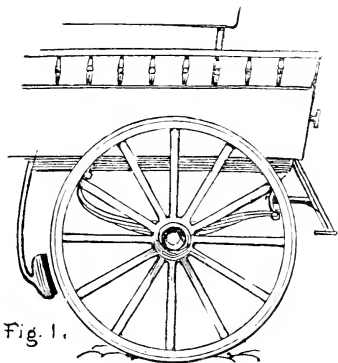

Fig. 1.

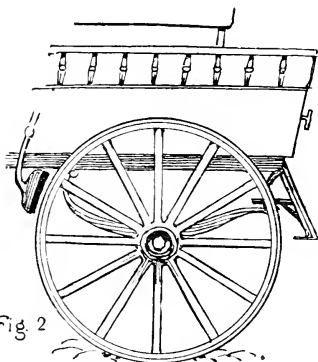

Fig. 2

easily answered. Have a foot brake which is more easy to work and when applied is more effective, always providing it is put on as it ought to be, so that when applied with sufficient power will skid the wheels.

The brake blocks as a rule are hung too low down, coming against the under turn of the wheel as in fig. 1; consequently when the coach or break is loaded the springs give a little, thereby throwing the brake block

off the wheels. Now, if the shank of the brake was made shorter, throwing the bearing of the block on the upper turn of the wheels, as in fig. 2, the extra weight of the coach when loaded would certainly assist the brake to hold firmer.

I have before remarked a man ought to know something about driving a team before he can be considered an expert in judging what kind of horses to buy to make up one. But it does not necessarily follow that a coach builder should be a coachman before he undertakes to build a coach, still I think it would be advisable and in the end give more satisfaction to those who purchase if they obtain the advice of some one who is known to have a really practical knowledge of the different kinds of breaks or coaches suitable to the different kinds of work for which they are intended. It by no means follows that a body break which was intended to be used almost exclusively for exercising should be recommended by carriage builders to an intending purchaser as a fair and safe vehicle to make a trip over a rough or mountainous country.

I in no way wish to infer that a break is more unsafe than any other kind of a coach or drag, providing the seats are arranged so that when loaded the weight is evenly balanced; but where the extra seat is put on close behind the box seat, which when full throws the

whole weight in front, makes it positively unsafe when driving over rough roads or making sharp turns. Coaches and drags not being altogether suitable for those who may wish to take a tour through the country we must look for something with enough seating capacity sufficient to accommodate eight to twelve persons with enough room to store the necessary outfit required on a long trip.

The outing coach I consider a really great improvement upon the old-fashioned drag for outing trips. It looks equally well in the Park, and is much better adapted to American roads, having strength and lightness combined; each and every passenger gets a front seat, that is to say, they can all see the way they are going.

There is a boot in front and behind; a door at the back to give access, in fact the whole length of the body being hollow gives unlimited space for everything necessarily required for the comfort externally and internally of the coaching party—luncheon case, hand-bags, valises, dressing cases, hat boxes, rugs, wet weather coats and aprons, horse-clothing, head collars, extra harness collars, hame straps, a box containing monkey wrench, screw nuts, clips, oil can, extra washers, package of pearline, which will be found not only useful to wash grease off the wheels, but as a pickle in which to put

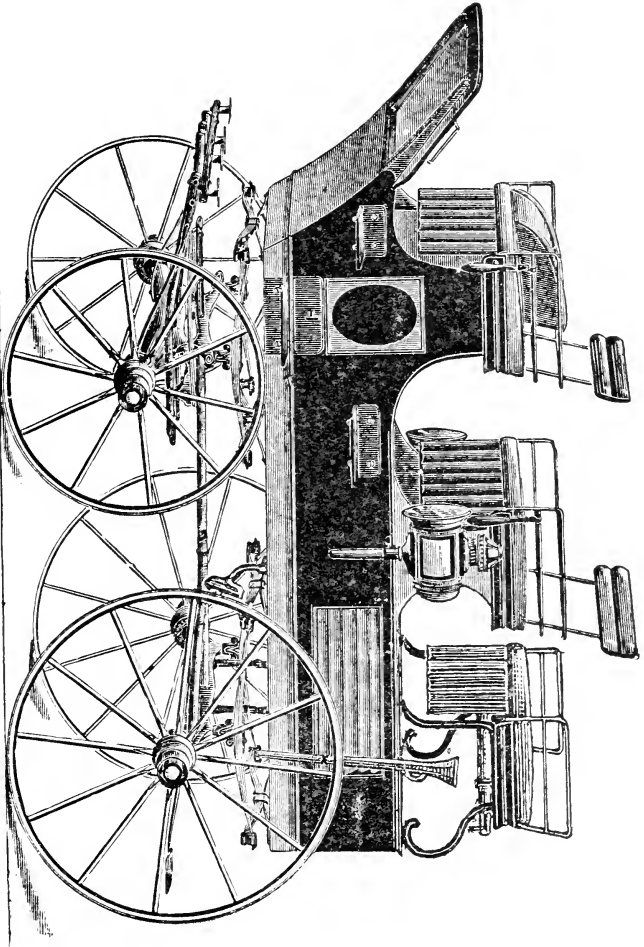

OUTING BREAK

BUILDER

A. J. WALKER

142 E. 41st Street N. Y.

steel bits, pole chains, etc., to prevent them from rusting, and two chain traces about 7 feet long, made with a hook and eye at each end. They can be used for lead or wheel, and they can be made any length, and if required can be used temporarily as a pole chain. Using them together they will be found useful as lead traces if the assistance of an extra horse is required when ascending hills or mountains.

When starting out on a coaching trip to be well equipped is half the journey. The harness should be well inspected, especially if it has been in use any length



of time, and if buckle worn or weak in any place have it repaired and strengthened. Now, from my own experience of coaching in England I must say that coach owners, both public and private, use the very best harness that they can get. It is to their interest to do so. It lasts longer, looks better and is not so liable to break. It is well finished, smooth made, fits as it ought to, and therefore not irritating to the horses, far different and a much superior article to that recommended and sold by an enterprising firm in New York as road harness, but which is used almost exclusively by omnibus proprietors on account of its cheapness.

SIX IN HAND.

Coaching men as a rule decry the idea of any one man driving six horses properly, that is, in a coachman-like style. Taking the men as a whole who are usually employed for this kind of work, I must admit they are to a certain extent correct. There are also numberless men who drive a pair and make hard work of it, whereas another—here I mean a coachman—drives four with more ease to himself and even less exertion; so it is with six, although I must be excused for “blowing my own horn.” I can drive six equally as well as four, and really better than some who imagine they are in the front row as four-horse coachmen.

The six-horse coaches as used in the West are no doubt driven by men who as far as artistic skill is required would be unable to drive a pair down Broadway, and the coachman who could with ease drive a pair in the city would be totally incapable to guide—I cannot say drive—the six horses for a stage over the wild Western plains.

As an illustration of this fact I wish to mention an amusing incident of which I was an interested spec-

tator. It was on the morning of the celebration of the Centennial, in 1888. An old-fashioned Concord coach was brought from the West to take part in the procession. It had been previously advertised in the daily press as being a true representation of the Western coach, and was to be driven by a regular Western driver. I happened to be on the corner of Fifty-fourth street and Sixth avenue when the coach with six horses came down Fifty-fourth street towards the avenue on its way to join the parade. The driver was sitting on the box-seat in a half stooping position, with his hands and arms extended over the foot-board, grasping three reins in each hand and the whip with the thong tied in a bow helplessly resting in the whip-socket. I shall never forget the look of despair which the driver exhibited when reaching the corner, which I presume he wished to turn, judging by the orders he gave the two men who were evidently acting as running footmen—one on each side of the leaders. With their assistance the corner was turned with difficulty, the driver never once altering or shortening his reins. He appeared to have no idea of knowing how to make a turn, and it was really distressing to see him at work. I have, however, been repeatedly told stirring stories of the dexterity of these Western six-horse drivers, and a little incident which occurred not very long ago is

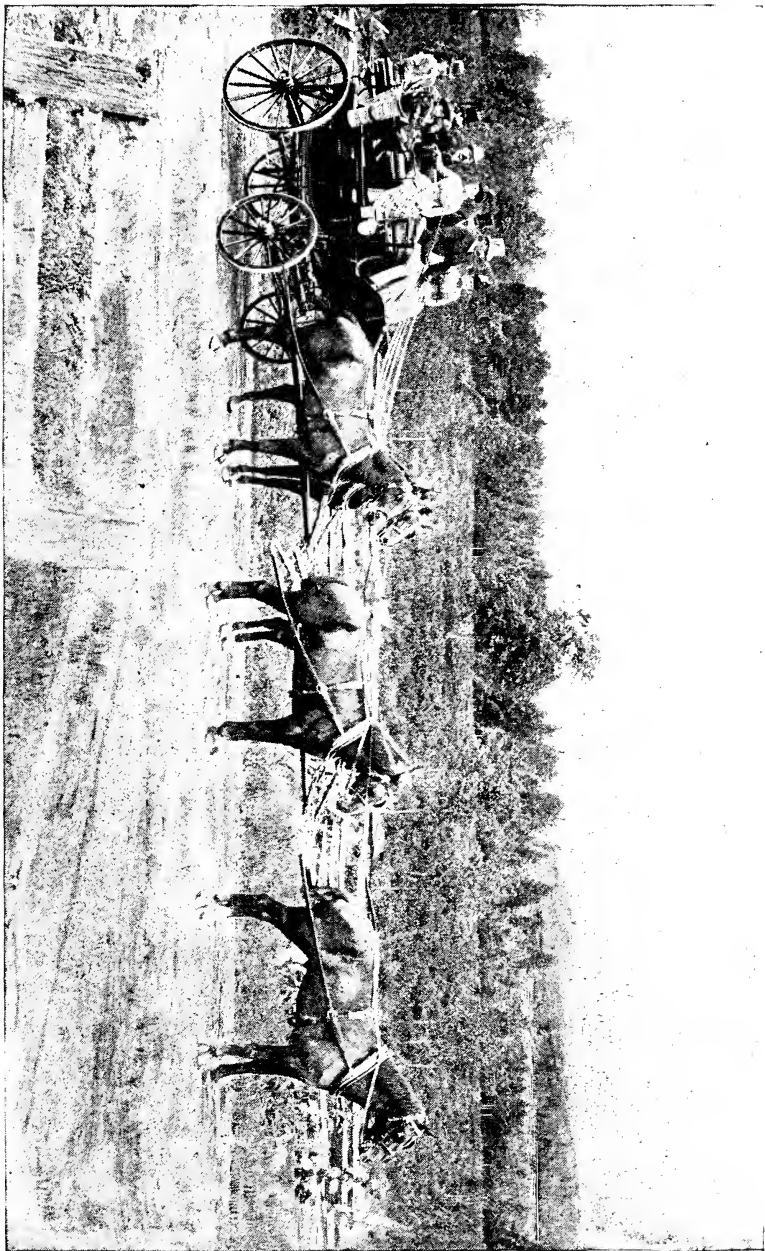

COACH "MOHICAN."

brought to my mind and may be of interest to my readers. While driving the Mohican I had an entire family from the West, and as they had travelled extensively on the coaches out there they evidently imagined that city coachmen were "not in it" with the Western drivers. We were returning home and ascending a long steep hill nearly a mile in length. The horses were walking, and even at this pace found plenty to do to keep the coach moving. The party were beginning to feel uneasy about getting to the hotel in time for dinner, so they requested me to go a little faster, but not acceding to their request, one of the gentlemen commenced to recite his coaching experiences in the West, making special mention of a certain driver by the name of Hank, who, he said, drove up and down hills at a furious pace. I was silent, but went along very steadily until I came to the top of the hill, when I put on the brake and commenced the descent, which was very steep. There were embankments on each side of the road, which naturally got higher as we descended. There was a lake at the bottom of the hill directly in front of us, and the turn to the right which I intended taking was almost imperceptible to the party. As a rule, when commencing to descend steep hills, I go very steadily, giving myself an opportunity to see if the brake holds good and is

all right before getting up steam. My intentions were evidently not perceived by the party, and they commenced to reiterate the wonderful driving of the Western wonder, the famous Hank, over again. I had already come to the conclusion that Hank's name was brought in to me as a hint to go faster and felt an inclination coming over me to find out how brave these gentlemen really were, so, without saying a word, I let go the brake and set the horses going, and they being good ones away they went, in fact, they went so fast that the coach began to sway. Suddenly some one grasped me from behind. It was the gentleman who had been relating the wonderful adventures of Hank, and he called out, "What are you doing? For God's sake stop!" The ladies screamed, for those who were unacquainted with the road and the turn at the bottom really expected that I was going to drive them into the lake. When nearing the bottom of the hill I pulled my horses to a trot and safely rounded the corner. After regaining breath, the gentleman asked me what had happened. I replied, "Nothing. You gave me so much Hank, I thought I would give you a little in return," and that little appeared to have a very depressing effect on him, for never another word was spoken during the remainder of the journey.

That six horses can be driven with perfect safety

under all possible conditions I have proved to my own satisfaction and that of many others. When I say to drive I really mean what I say, and not merely holding the reins and perhaps only three or four of the six horses doing any work, but to have each one reined, bitted and put to, so that when driven a few times

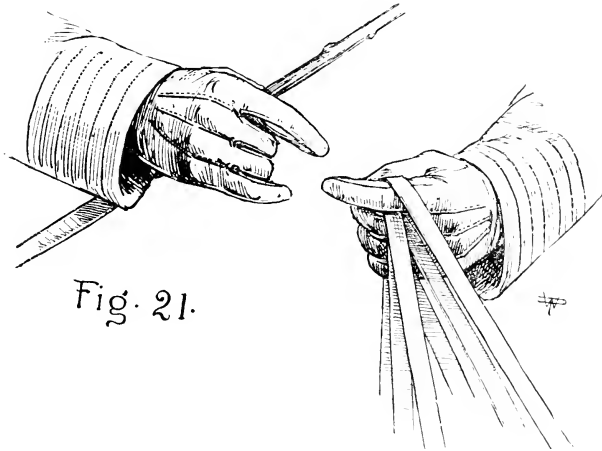

Fig. 21.

they are as easy to drive as four, and require no more room to make a turn in. The reins should be held in the left hand the same as with four; excepting that the wheel reins are placed on each side of the third finger, the swing or middle pair each side of the second and the leaders each side of the first or top finger as in fig. 21. In making turns the lead and swing reins

are looped at one and the same time, as in driving four, and illustrated in fig. 12. The easiest and best way to shorten any individual rein or take them up is to pull them through the fingers of the left hand with the right, which should at all times be free. Never separate the reins from the left hand. Coachmen who can drive a team well and who possess nerve, good hands and judgment will not find it so difficult as might be imagined to drive six-in-hand with ease and safety.

Amongst my readers there are some no doubt who have had the good fortune to enjoy a ride on the six-horse coach "Mohican," running from Richfield Springs to Cooperstown, commencing in 1888. It is owned by Mr. Eugene Earle of the "Hotel Earlington," formerly the "New American," and although running as a public coach, was used almost exclusively by his guests and was a pronounced success. The following season, 1889, it was again put on the road, but through unforeseen circumstances and bad management on the part of those interested in the contract for supplying the horses, it was speedily taken off. The next season, 1890, the coach, having undergone a complete renovation, it was again started, and considering the short time it ran, was well patronized. This was only natural; for a more pleasant and enjoyable trip than that from Richfield Springs by way of the little lakes, then through a fertile and lovely

farming country to Maple Grove, is not surpassed in any country. The last half of the drive to Cooperstown there is about eight miles of excellent road, extending the whole length of Otsego Lake, with its clear waters, and beautiful scenery, made famous by the works of Fennimore Cooper. If preferable, the passengers can alight at Maple Grove, which is the head of the lake, and finish the trip on the "Nattie Bumpo," a small steamer which takes a circuitous route along the lake, arriving at Cooperstown about the same time as the coach, in fact, both are in sight of each other the whole way. The passengers can then resume their seats on the coach and continue the trip, which includes a visit to the Cooper House, and a drive through the streets of this pretty little town. On the return trip the first stop is at Thayers' Three-Mile Point House, famous for its fish and game dinners which are, as a rule, heartily enjoyed by the passengers after the twenty-mile ride. Two hours are allowed for refreshments. Many avail themselves of the boating, fishing, and other amusements. A start is then made for home, arriving at Richfield Springs at 6 P. M., in good time for dinner.

THE OLD TIMES.

Some people delight in the sport of the turf
 Whilst others love only the chase,
But to me the delight of all others is
 A coach that can go the pace;
There are some, too, for whom the sea has its charms
 And who sing of it night and morn ;
But give me a coach with its rattling bars,
 And a guard who can blow his horn.

How the girls all doat on the sight of a coach,
 And the dragsman's curly locks,
As he rattles along with eleven and four
 And a petticoat on the box.
His box is his home, his team his one pride,
 And he ne'er looks downcast or forlorn ;
And he lists to the musical sound of the bars
 And a blast on the old Mail Horn.

—OLD COACHING SONG.

COACH "TALLY HO."

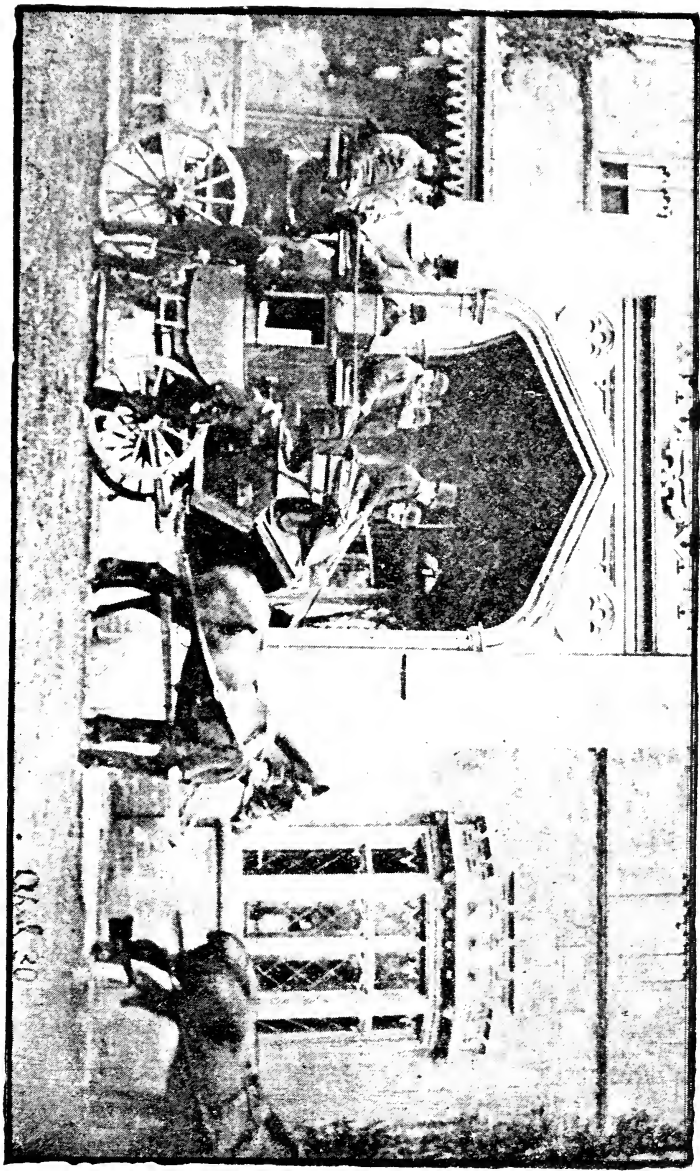

COACHING IN AMERICA.

The revival of coaching in England, some few years since, had no more enthusiastic admirer than Colonel Delancey Kane. He not only took a principal part in it himself by running a coach, but conceived the idea of introducing this most attractive mode of travel to the people of the United States, and to him alone must be given the credit of inspiring the lovers of horses to indulge in this healthy recreation.

In the year 1875, the "Tally Ho" was running from London to Virginia Water, with Edwin Fownes, Sen., as professional Coachman, Guide, and Mentor. The Colonel soon became thoroughly initiated into all the little points and ideas, which are necessary to be learned to become a practical coachman.

The following year the Colonel returned to New York bringing the "Tally Ho" and Arthur Fownes, son of his former mentor, with him, to act as guard, in which capacity he has had no equal on this side of the water. It is a great pity that the example he set, regarding the proper time to sound a call, and the proper call to sound, was not followed as an established standard. It ought to be

more clearly understood, that a guard is not merely one who can make a noise; he should know what to blow, and what he blows for.

The following is a brief history of "Coaching in America. In 1876 the "Tally Ho" made its first appearance during the spring season, starting from New York (Hotel Brunswick) to Pelham (Arcularuis Hotel). The start each day being witnessed by admiring crowds of people, and it proved such a pronounced success, that it was decided to put it on the road in the fall, and the journey was extended to New Rochelle (Neptune House). The following season, 1877, a different road was selected. The "Tally Ho" running to Yonkers (Getty House), starting from (Hotel Brunswick), New York.

The "Tally Ho" was put back again on the New Rochelle road in 1878, running from (Hotel Brunswick) New York to New Rochelle (Hugenot Hotel), but in consequence of the bad condition of the roads, the coach had to stop running. During the foregoing season A. Fownes acted as guard and coachman. To show that the interest taken by the public in coaching was not allowed to abate, the following article copied from the "New York Herald," of April 3, 1880, may be interesting reading: "On Wednesday, April 21, Colonel DeLancey Kane will start with his coach 'Tally Ho' for the season of 1880. From New York to New

Rochelle is the route selected, and the same places as in former years will be passed through, viz., Harlem, Mott Haven, Fox's Corners, Westchester, Pelham Bridge and Pelham. The changes of horses will take place as formerly. During the past winter the coach has been entirely reappointed, the original color having been retained. A glance at the official time table below shows that the "Tally Ho" will leave the Hotel Brunswick at 10 a. m. and arrive at New Rochelle at 12 m. Fully three hours and a-half may be passed at the Castle Inn, as the horn of the guard will not give notice of the return trip until half-past 3 p. m. At half-past 5 p. m. the Hotel Brunswick will be reached. Beside the attraction of the route, which is one of great beauty, always pleasant, often picturesque, and occasionally romantic. Travelers by the "Tally Ho" will find a most charming old-fashioned hotel in the Castle Inn. The house has been leased by the Queen's County Hunt, with forty acres of land surrounding it, for a hunting headquarters, and they have furnished it, so as to make it a regular old-fashioned country hotel of the first-class. Passengers will find on the grounds the Hunt model kennels, which have just been completed, containing over forty hounds, ten additional couples having arrived from England on Thursday last. There are now over thirty horses in the Hunt stables, and fox hunting in its best form is regular.

ly carried on every Wednesday and Saturday at half-past 1 p. m. The field is open to all comers, and every body will be made welcome.

“Much has been done to the roads by the village authorities, through which the coach will pass, and the road between Pelham Bridge and New Rochelle is now being macadamized by the residents of the neighborhood in view of the ‘Tally Ho’s’ return.

The coach, in short, will be well-horsed, admirably managed and capitally driven. It will as heretofore run regularly, rain or shine. The Coaching Book will be open in a few days, when places can be secured for weeks in advance.

As stated in the foregoing article, the roads had been repaired and the weather being exceptionally good, that season, everything proved very satisfactory.

In this year Frank Swales was professional coachman, and H. Distin acted as guard. It will not perhaps be out of place to mention that the name “Tally Ho” has been wrongly applied to every old ramshackle vehicle drawn by four horses. It would be equally reasonable to name a barge or rowboat “Mayflower” or “Volunteer,” as to call all coaches “Tally Hos.”

There being no new aspirant in 1881 to take up and follow in the footsteps of the Colonel, who during the time the “Tally Ho” ran, was sole proprietor, and bore

the entire expense himself. A few members of the Coaching Club, at that time in its infancy, started the "Tantivy" by subscription, and starting from New York (Hotel Brunswick) made the (Tarrytown Hotel) Tarrytown, its terminus, A. Fownes, professional coachman, and R. Graham acted as guard.

The following are the coaches in chronological order and may be used for reference:

1882. The Tantivy's second appearance, running from New York (Hotel Brunswick) to Yonkers (Getty House), H. Evans, guard.

1883. No coach ran this year

1884. "The Greyhound" started on its first trip from New York (Hotel Brunswick) to Pelham (Country Club).

C. D. Iselin, G. R. Roosevelt,
Proprietors.

H. Distin, guard.

1886. The subscription coach "Tantivy" again made its appearance this season running to (County Club) Pelham, from New York (Hotel Brunswick).

F. Cunard, guard.

1887. The "Tantivy" starting from New York (Hotel Brunswick) running to Pelham (County Club).

F. Swales, prof. coachman,
F. Cunard, guard.

1890. The "Tantivy" starting from New York (Hotel Brunswick) to (County Club) Westchester.

H. Distin, guard.

The principal owners of the "Tantivy" were Colonel Jay, Frederic Bronson, Esq., Hon. Hugo Fritsh, Isaac Bell, Esq., T. R. Roosevelt, Esq., and Reginald Rives, Esq.

1891. In consequence of the bad condition of the roads there was no coach run this year.

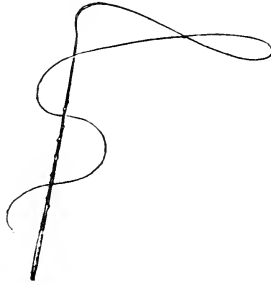

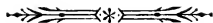

ALL ILLUSTRATIONS IN THIS WORK ON DRIVING
DRAWN BY WALTER PETTEE ARE COPYRIGHTED AND
CANNOT BE USED WITHOUT THE CONSENT OF THE
PUBLISHERS.



LONDON HARNESS AGENCY.



Highest Award Paris Exposition, 1890.

MARTIN & MARTIN,

MANUFACTURERS OF

LONDON WEST END HARNESS AND SADDLERY.

Our stock comprises full line of Four-in-hand, Tandem, Landau, Brougham, T Cart, Dog Cart, and Russet Leather Harness suitable for Surreys and Buckboards.

All newest designs in Driving Aprons, Crook Whips, Coach, Post and Tandem Horns, with extra extensions to improve the tone. Patent rubber mouthpieces.

SADDLERY.

CROPS,

SPURS,

FLASKS,

POLO

GOODS,

WHIPS.



REGISTERED MARTIN SADDLE.

LADIES' & GENTS'

RIDING & DRIVING

CLOVES.

FOWN'S,

SLEEP'S,

DENT'S,

GRANT'S.

EVERY ENGLISH STABLE REQUISITE KEPT IN STOCK.

All goods sold by us are made at our London West End Establishment. **THE VALUE AND MERIT** we offer cannot possibly be equalled by any other house, as all **INTERMEDIATE PROFITS** are saved.

LONDON HOUSE: 103 Gloucester Road, South Kensington, London.

PHILADELPHIA: 1,713 Chestnut Street.

AND

235 FIFTH AVE., near 27th Street, NEW YORK.

CARRIAGES

FOR

THE BOULEVARD,

THE PARK,

THE COUNTRY,

THE SEASHORE,

AND

FOR PROFESSIONAL AND BUSINESS USE.

Each and Every One Adapted for Its Special
Purpose.

KIMBALL BROS.,

FACTORY AND WAREROOMS,

NOS. 110, 112 AND 114 SUDBURY STREET,

BOSTON.

JENKINS,



304 FIFTH AVENUE,

NEW YORK AND LONDON.



Specialties : Liveries,
Riding Breeches and Leggings,
Hunting and Driving Suits.

Successors to Messrs. Redfern & Son's, Gentlemen's Department.
Late with Hammond & Co., Celebrated Breeches Makers, London.

HANSON
 CABS,
 SKELETON
 AND
 Body Breaks
 AND
 ALL KINDS
 OF
VEHICLES
 OF
SPECIAL
 DESIGNS
 Built to Order.

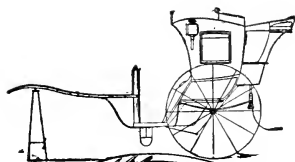

FINE
 REPAIRING
 IN ALL
 BRANCHES
 PROMPTLY
 EXECUTED
 AT
 MODERATE
 PRICES.

ALFRED J. WALKER,
CARRIAGE MANUFACTURER,

142 EAST 41ST STREET, NEW YORK.

ESTIMATES FURNISHED.

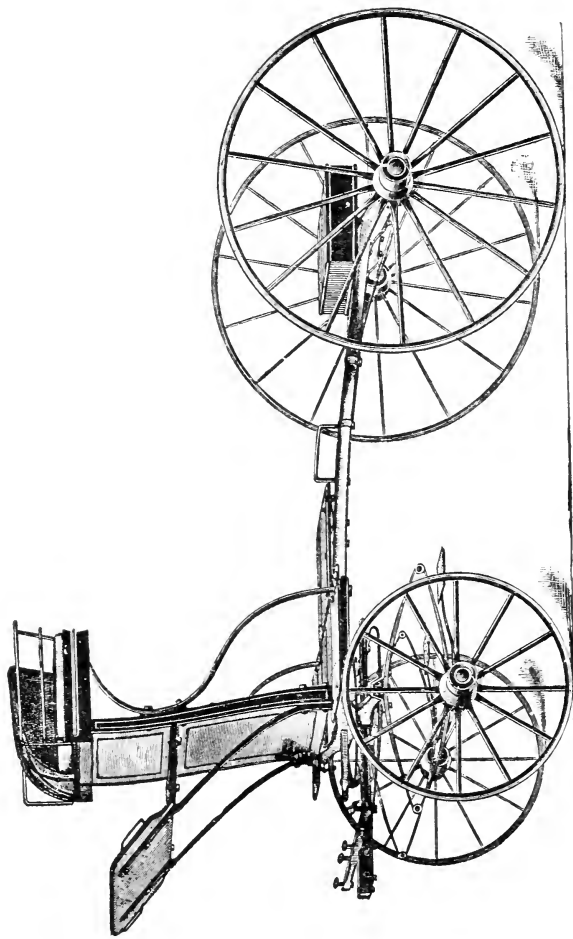

SKELETON BRAKE.

Builder, A. J. WALKER.

Do Your
BUCKETS
 Ever Look Like
THIS?

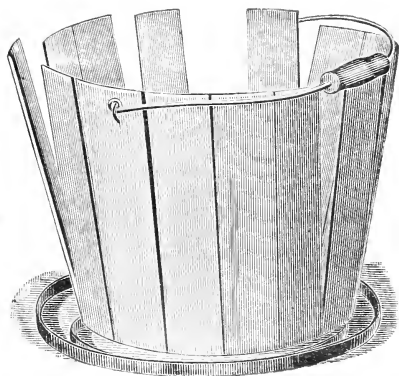

Or do they grow so
 FOUL and SOUR your
 Horses will not drink
 from them?

Why not have THIS
 kind?

Have you any PRO-
 TECTION against FIRE
 about your stable?

**WRITE FOR
 FULL
 CATALOGUE.**

CORDLEY & HAYES, Sole Agents,
 173 and 175 DUANE STREET, NEW YORK.

ESTABLISHED 1835.

ENGLISH AND FRENCH HARNESS AGENCY.
HANLON & CO.,

Stable

Outfitters.

Correct

Styles.

Vienna

Leather

Goods.



254 BOYLSTON STREET, BOSTON, MASS., U. S. A.
Agents in America for French Straight Seat Saddles.



D. TOY,
TAILOR AND IMPORTER,
71 BEACON ST., BOSTON.

Agent for WHITAKER & CO. and HILL BROTHERS, London, West.

DENT'S

ENGLISH DRIVING GLOVES;

ALSO

Walking, etc., for Ladies and Gentlemen,

TO BE OBTAINED OF ALL

High-Class Men's Furnishers and Other Dealers
Throughout the World.

DR. W. T. CARMODY,

(Member Royal College Veterinary Surgeons, London.)

VETERINARY SURGEON,

Office: 826 Seventh Ave., Corner 53d St., New York.

Telephone Call 632 38th St.

Residence, 60 West 37th St., N. Y.



JOHN REYNDERS & CO., OPTICIANS.

The highest grade of spectacles, eyeglasses, opera and field glasses.

Our latest novelty The "Electric" Race and Field glass with instantaneous opening and closing arrangement.

Oculists' Formulæ receive our careful attention.

303 Fourth Avenue, N. E. Cor. 23rd St.,
NEW YORK.

PETER WHITE.

+—+

BENJAMIN KERR.

WHITE & KERR,

HARNESS MANUFACTURERS.

LANDAU, BROUGHAM, T-CART, COUPE, DOG CART, TANDEM,
AND FOUR-IN HAND HARNESS, CUSTOM
MADE AND TO ORDER.

LIGHT ROAD HARNESS A SPECIALTY.

All Requisites for the Stable Constantly on Hand and of the Best Quality.

13 EAST 27th STREET, NEAR FIFTH AVENUE.

A. F. MÜLLER,

HABIT MAKER,

Inventor and patentee of the

IMPROVED AMERICAN
RIDING HABIT SKIRT.

*Unsurpassed in Fit, Elegance
Comfort and Safety.*



NOTICE TO OUT-OF-TOWN
LADY PATRONS.—Unless
measure for bodice can be
taken and fitted in my estab-
lishment, orders for riding
skirts only will be received
and executed, and cloth sold
for bodice. Directions for tak-
ing measurements for skirt
sent on application. No pat-
terns sold.

14 West 23d Street,
Opposite Fifth Avenue Hotel, NEW YORK.

FREDERICK LEE,

MANUFACTURER OF

BEST LONDON HARNESS AND SADDLERY,

65 LONG ACRE, LONDON, ENGLAND.

I take great pleasure in announcing that I have opened a BRANCH Establishment at

No. 5 W. 26th St., New York,

(OPPOSITE DELMONICO'S.)

where will be offered for inspection a choice selection of very best LONDON HARNESS and SADDLERY.

It is now over 20 years since my manufactures were first introduced into the States, and the increasing demand for same has necessitated the opening of the above premises.

Should you trust me with any of your kind favors, I assure you that you will find my goods of the very finest quality, at the most reasonable prices, and your wishes carried out with promptness.

Thanking my many patrons for their past favors, I am,

Yours Respectfully,

FREDERICK LEE.

JOHN M. JENNY,

NEW YORK LIVERY

BOOT MAKER,

19 WEST 28TH STREET,

Two doors East of Broadway,

NEW YORK.

A large assortment of English Boots and Tops constantly on hand.

JOHN WIRTH,

MERCHANT TAILOR

155 WEST 28TH STREET,

Bet. 6th and 7th Aves.,

NEW YORK.

Liveries a Specialty.

DRIVING LESSONS.



Ladies and gentlemen taught to drive
Tandem or Four-in-hand.

Horses bought and sold on commission
and broken to all kinds of harness.

Terms on application.

F. SWALES,

109 West 33d Street.

Also care of

J. T. BURGESS,

54 West 23d Street.

“DRIVING AS I FOUND IT.”

For sale at all the principal Book Stores
and Harness Agencies throughout the United
States, or at either of the above addresses.



