

UC-NRLF

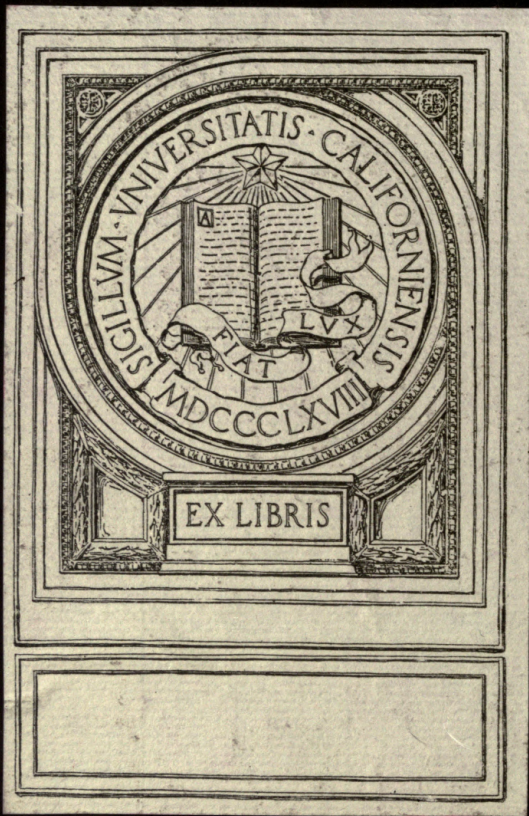

\$B 113 999



EX LIBRIS



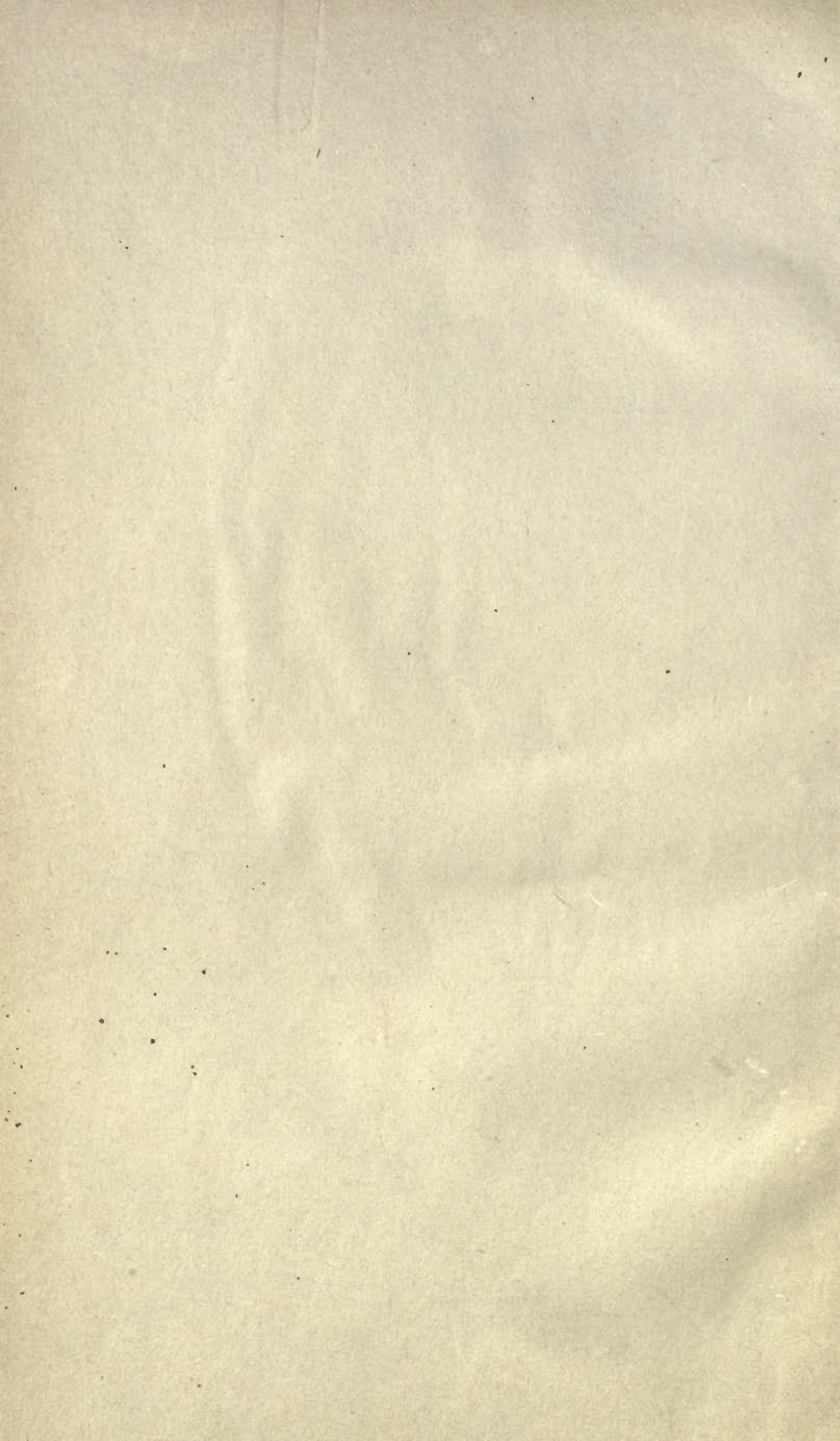





THE EARLY MOTIVE POWER  
OF THE  
BALTIMORE and OHIO  
RAILROAD

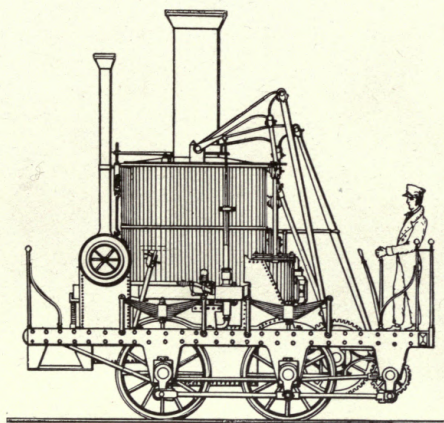

BY

J. SNOWDEN BELL

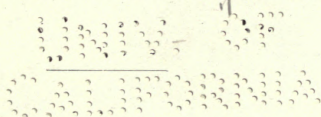

NEW YORK:

ANGUS SINCLAIR CO., PUBLISHERS.

1912.

TJ603  
B3

COPYRIGHT, 1912  
BY  
J. SNOWDEN BELL





## PREFACE

A historical review of the origin and development of the motive power of the Baltimore & Ohio Railroad so largely comprehends that of the locomotive upon other railroads in the United States as to render it of more general interest and less local in its scope than might be inferred from its title. Descriptions, not always entirely accurate, of some of the early locomotives of the Baltimore & Ohio Railroad have appeared, from time to time, in technical literature, but no complete or classified description of all of the types used on that road, prior to the introduction of those that may properly be classed as modern, has ever been presented.

The non-existence of records as to many of these early types, the loss and destruction of records of others, and the fact that but very few of those who were familiar with them are now living, necessarily render the preparation of such a description a matter of difficulty, and its completeness one of impossibility. In undertaking it, the writer is aware that he is entitled to no credit beyond that of a compiler, and his work is submitted, with a full recognition of its imperfections, in the hope of rescuing from oblivion those examples of early practice, which, while, perhaps, no longer instructive to the designer of locomotives, were novel and progressive at their date, and have embodied principles and features that are still accepted as correct and practical.

The writer acknowledges his obligations for information furnished and courtesies extended, to Messrs. O. C. Cromwell, Mechanical Engineer Baltimore & Ohio Railroad; R. H. Sanford, of the Baldwin Locomotive Works; C. H. Caruthers, Yeadon, Pa., and Herbert Fisher, Taunton, Mass.

J. S. B.

Singer Building, New York, April, 1911.



# Table of Contents

## INTRODUCTION.

	PAGE
Baltimore & Ohio Railroad, chartered February 28, 1829.....	1
Recognition of pioneership of B. & O. R. R.....	2
John H. B. Latrobe's account of early events.....	3, 4
B. & O. R. R. line over Allegheny Mountains, commenced in 1849.....	4
B. & O. R. R. "first stone" laid July 4, 1828.....	4
Performance of Peter Cooper's experimental locomotive, August 28, 1830.....	5
Description of Peter Cooper's experimental locomotive.....	7, 8
Plan of classification of locomotives up to October 1, 1860.....	11

## CHAPTER I.

### THE "GRASSHOPPER" AND "CRAB" ENGINES—TYPE 0-4-0.

First proposal for the construction of locomotives in the United States, made by B. & O. R. R. Co., January 4, 1831.....	13-15
Performance of first successful locomotive, the "York".....	15
Account of the locomotive tests by B. H. Latrobe.....	16, 17
First "Grasshopper" engine, the "Atlantic," September 1, 1832.....	17-19
The "Traveller" and "Arabian" of the same class.....	19
Four of these engines in service October 1, 1834.....	20
Seven in service October 1, 1835.....	20
Gillingham & Winans take the Company's shops and continue the manufacture of rolling stock, 1835.....	21, 22
Introduction of the "Crab" engines with horizontal cylinders.....	22
Thirteen locomotives in use in 1837.....	22
The "Crab" engines as shown in the Patents of Ross Winans.....	22-29
The "Crab" engines as subsequently modified and operated.....	29, 30

## CHAPTER II.

### THE "ONE-ARMED BILLY" ENGINES—TYPE 4-2-0.

Zerah Colburn's acknowledgment of American originality.....	31
The swivelling leading truck invented by John B. Jervis, and put in service in the summer of 1832.....	31
Adoption of the swivelling truck in the early engines built by Baldwin and Norris.....	32
Performance of engine "George Washington" on inclined plane near Philadelphia, July 10, 1836.....	32
Eight Norris engines of 4-2-0 type placed on B. & O. R. R., between April, 1837, and November, 1839.....	33
Dimensions of Norris 4-2-0 engines.....	34

## CHAPTER III.

### THE GENERAL SERVICE PASSENGER ENGINES—TYPE 4-4-0.

Locomotive having four driving wheels and four wheel leading truck, patented by H. R. Campbell, February 5, 1836.....	35
Equalizing lever invented by Joseph Harrison, Jr., and patented by him April 24, 1838.....	36
First 4-4-0 engine of B. & O. R. R., the "Atlas," built by Eastwick & Harrison, September, 1839.....	38
Four engines of this type, the "Vulcan," "Jupiter," "Mercury," and "Minerva," by the same builders, July, 1840 to February, 1842....	38
Eastwick's reverse gear, patented July 21, 1835, and applied on B. & O. R. R. engines.....	39
Three 4-4-0 engines by William Norris, the "Pegasus," "Vesta," and "Stag," November, 1839 to May, 1843.....	40
Three engines of same type by Ross Winans, the "Atalanta," "Reindeer," and "Juno," October, 1843 to January, 1848.....	40
Five engines of same type by New Castle Manufacturing Co., the "Arrow," "New Castle," "Delaware," No. 122, and No. 164, February, 1840 to July, 1853.....	41

TABLE OF CONTENTS—Continued

"Arrow" first inside connected engine of B. & O. R. R.....	41
Four inside connected engines, called the "Dutch Wagons," built by B. & O. R. R. Co., January to September, 1852.....	41
Two of same class by Richard Norris & Son, December, 1853, and January, 1854 .....	41
Two more of same class by Murray & Hazlehurst, July and November, 1854 .....	41
Five engines of same general design, by Lawrence Manufacturing Co., July, 1854 .....	41
Two 4-4-0 engines, outside connected, with independent cut-off valves, by Richard Norris & Son, January, 1853.....	46
Engines Nos. 25 and 26, first 4-4-0 engines of modern type, built by Wm. Mason & Co., and placed on road, November, 1856.....	46
Engine No. 27, by Taunton Manufacturing Co., January, 1859.....	47
Engines Nos. 220 and 221, by A. & W. Denmead & Sons, February, 1857.....	47
Henry Tyson, Master of Machinery, orders the first Mason engines in 1856 .....	47
Engines Nos. 231 and 237, the typical Mason engine of 1857, placed on road August, 1857 .....	50
Engine No. 188, built by Company, November, 1858, an exact duplicate of engines Nos. 231 to 237.....	50
Characteristic features of the Mason engine.....	50
Engine No. 42 of practically the same design.....	52
Boilers of the Mason engines.....	52
Bed plate or saddle originated by Wm. Mason.....	52-54
Less than fifty engines of 4-4-0 type in use on B. & O. R. R. in 1860, and none with driving wheels exceeding 60 inches diameter.....	54

CHAPTER IV.

THE EIGHT-WHEEL CONNECTED FREIGHT ENGINES—TYPE 0-8-0.

Ross Winans constructed an engine of this type, weighing 20 tons, as early as March, 1842.....	55
This engine was in accordance with design shown in the Winans Patent No. 3201, June 28, 1843.....	56
Report of Geo. W. Whistler, April 20, 1849, states that in October, 1844, Ross Winans produced the first successful coal-burning engine with a horizontal boiler .....	56
The "Mud Digger" engines of Ross Winans were the first of the 0-8-0 type on the B. & O. R. R.....	57
Twelve engines of this class built by Ross Winans, and placed on the road between October, 1844, and November, 1846.....	57
One engine of similar design, the "Mount Clare," built by the Company, May, 1847 .....	58
Next class of 0-8-0 engines was that built by M. W. Baldwin, with inclined cylinders and independent cut-off valves.....	58
Engine "Dragon," No. 51, the first of this class, was placed on the road in January, 1848.....	58
Baldwin "flexible beam truck" applied in the "Dragon".....	59
Colburn's remarks on the "flexible beam truck".....	60
Advertisement by the Company for proposals for four 0-8-0 type engines, September 18, 1847.....	61, 62
Three locomotives, the "Hector," "Cossack," and "Tartar," built by M. W. Baldwin under the Company's specifications.....	62, 63
Illustration of design prepared by Company for these engines.....	64
Modification of contract as to variable exhaust and chilled tires.....	65, 66
Perkins & McMahon tire fastening, Patent No. 3037, April 10, 1843..	66
Engine "Saturn," of same design, built by New Castle Manufacturing Co., June, 1848, and engine "Memnon," stated in Company's report as built by M. W. Baldwin, October, 1848.....	67
Engines "Hero," "Giant" and "Lion" of the same design, built by the Company, 1848-1850 .....	67
Feed water heating apparatus applied to engine "Hero," No. 54.....	67, 68
The "Company's eight-wheel" engines, October, 1850, to November, 1853.....	69, 70
The "Camel" engines of Ross Winans.....	70

TABLE OF CONTENTS—Continued

Distinctive features of novelty of the "Camel" engines.....	71
First engine of this class, the "Camel," No. 55, placed on road in June, 1848 .....	71
Medium length furnace with inclined top fire-box and top fuel feed chutes .....	72
M. N. Forney's remarks on the "Camel" engines.....	73
Ross Winans advertising lithograph of these engines.....	75
Enumeration of "Camel" engines on B. & O. R. R.....	74
The long furnace "Camels," ten placed on road in February, 1857.....	74
Valve gear of "Camel" engines .....	78-82
Ross Winans' variable exhaust, first design patented November 26, 1840, No. 1868 .....	82
Winans' second form of variable exhaust, patented April 10, 1847, No. 5056 .....	84
E. R. Addison's "coffee grinder" variable exhaust, patented October 13, 1857, No. 18373 .....	85, 86

CHAPTER V.

THE SIX-WHEEL CONNECTED ENGINES—TYPE 0-6-0.

Three engines of this type, the "Baldwin," "Wisconisco," and "Unicorn," built by M. W. Baldwin, December, 1846 to February, 1848.....	87
Description of engine "Unicorn" No. 51.....	87

CHAPTER VI.

THE TEN-WHEEL ENGINES—TYPE 4-6-0.

Two classes of this type in the early motive power, the "Hayes ten-wheelers" and the "Tyson ten-wheelers".....	88
Description of the Hayes ten-wheelers by W. S. G. Baker.....	88-91
Seventeen engines of this class put in service between July, 1853, and November, 1854 .....	91
Specification for Tyson ten-wheel engines and letter of Henry Tyson to Ross Winans .....	92-95
Proposal of Ross Winans for modification of specification.....	96
Nine Tyson ten-wheel engines placed on road in 1857.....	96
The Winans and Tyson controversy as to the merits of the "Camel" and "Ten-Wheel" engines .....	98-123

CHAPTER VII.

THE LATER LOCOMOTIVE DESIGNS OF THATCHER PERKINS, AND THE FIRST MOGUL PASSENGER ENGINE.

The first Perkins ten-wheel passenger engine, No. 117, placed on road in 1863 .....	124
Combustion chamber boiler of engine No. 117.....	126
Description of Perkins ten-wheel engines.....	124-128
Perkins 4-4-0 passenger engines.....	128
Perkins eight-wheel connected engines.....	128-130
Mogul passenger engine No. 600, by John C. Davis, 1875.....	131, 132

CHAPTER VIII.

EXAMPLES OF THE PRESENT MOTIVE POWER.

Switching engine No. 1184, 0-6-0 type.....	133
Passenger service engine No. 1430, 4-4-2 type.....	134
Heavy and fast passenger engine No. 2140, 4-6-2 type.....	134
Freight service engine No. 2718, 2-8-0 type.....	135
Freight service engine No. 4008, 2-8-2 type.....	135, 136
Freight and helper service Mallet engine No. 2401, 0-8-8-0 type.....	136, 137

CHAPTER IX.

EARLY MOTIVE POWER OFFICERS.

Phineas Davis .....	138, 139
Ross Winans .....	140-144
Samuel J. Hayes.....	145, 146
Henry Tyson .....	147, 148
Thatcher Perkins .....	149, 150
William H. Harrison.....	151, 152
Andrew J. Cromwell.....	153, 154



# The Early Motive Power of the Baltimore & Ohio Railroad.

## INTRODUCTION.

THE Baltimore & Ohio Railroad was not, strictly speaking, the first railroad that was built in the United States, it having been preceded by a three-mile road for the transportation of granite from quarries at Quincy, Mass., to the Neponset River, which was commenced in 1826 and completed in 1827; by a railroad nine miles long, from Mauch Chunk coal mines to the Lehigh River, also completed in 1827; and by a short railroad built by the Delaware & Hudson Canal Co. from its mines to Honesdale, built in 1828. Neither was its charter, as has been claimed, the first railroad charter obtained in the United States, it having been granted February 28, 1827, while that of the Mohawk & Hudson Railroad, now a part of the New York Central System, was granted April 17, 1826. The American edition of *Wood's Treatise on Railroads*, (Philadelphia, 1832) states, in its description of the Baltimore & Ohio Railroad (pp. 540, 541) that "Railroads had several years previously begun to attract attention in Pennsylvania, and a number of charters had already been granted in this State, and one in New York, authorizing railroads—several of which have been finished; but no extensive railroad then *existed* in the United States to encourage, by its results, the boldness which induced the present Company to undertake this important enterprise."

[The Baltimore & Ohio Railroad was, however, the first railroad of any considerable length, designed for the purpose of general passenger and freight traffic between terminals then considered to be widely separated, which was proposed and commenced, in the United States, and the first locomotive that was built in the United States, that of Peter Cooper, was successfully operated on it, at the early date of August 28, 1830.] Zerah Colburn, referring to the historic Rainhill test of locomotives on the Liverpool & Manchester Railway, which was made about ten months prior to the first run of Cooper's engine, i. e., on October 8, 1829, cor-

rectly says that "its results unquestionably fixed general attention upon the mechanical and commercial practicability of high speed locomotive conveyance," and it may properly be said that they so fully *demonstrated* its practicability as to satisfy the projectors of railroads that the locomotive engine was the only motor worthy of consideration for transportation upon their lines. At that early date, however, the operation of locomotives on railroads having gradients of any substantial inclination was hardly deemed to be even a possibility, and to the Baltimore & Ohio Railroad there must be awarded the distinction of being the first in this or any other country upon which such operation was, without the warrant and encouragement of experimental precedents, boldly proposed and successfully practiced. Its motive power was, from an early period in its history, designed and constructed upon original lines for heavy grade service, and, widely departing from foreign practice, presented the general features which, as developed and perfected by the natural course of structural improvement, characterize the standard heavy service locomotive of the present day.

The pioneership of the Baltimore & Ohio Railroad, and its influence in originating and promoting improvements in the construction of railroads and rolling stock, are recognized in the following extract from the *American Railroad Journal* of November 28, 1835, p. 401:

"We acknowledge the favor by the President of the Company, of a copy of the Ninth Annual Report of the Baltimore & Ohio Railroad Company, and cannot refrain from here expressing our own, and, we believe, the thanks of the whole railroad community as well in Europe as America, for the candid, business-like, liberal manner in which they annually lay before the world the result of their experience.

"It will not be saying too much, we are sure, to denominate them the Railroad University of the United States. They have labored long, at great cost, and with a diligence which is worthy of all praise in the cause, and, what is equally to their credit, they have published annually the results of their experiments, and distributed their reports with a liberal hand, that the world might be cautioned by their errors and instructed by their discoveries. Their reports have, in truth, gone forth as a text-book and their road and work-shops have been a lecture-room to thousands who are now practicing and improving upon their experience. This country owes to the enterprise, public spirit, and perseverance of the citizens of Baltimore, a debt of gratitude of no ordinary magnitude, as will



be seen from the President's report in relation to their improvements upon and performances with their locomotive engines, when compared with the performances of the most powerful engines in Europe, or rather in imagination, in 1829, only six years ago."

The late John H. B. Latrobe, who was familiar with the organization of the Company and was its counsel for many years, gave an interesting account of the events of its early days in a lecture delivered by him in Baltimore, March 23, 1868, the following extract from which is made as illustrative of the beneficial influence which its experience exerted upon the projection and development of railroads in Europe as well as in the United States:

"And yet the Company, stumbling along, with many a fall and many a bruise, made headway notwithstanding; and gave to the companies fast multiplying in all directions, the benefit of its experience. Nothing was more sought after by engineers than the Company's Reports. With a great deal now utterly useless, there was mixed a great deal of scientific and mathematical information. Accurate tables for the location of curves, for estimating quantities, for regulating grades, were to be found there. The Company's very errors imparted lessons of wisdom. What now seems simple was then abstruse; and it was only natural that the managers of new works should resort to the first railroad which had arrived at practical results in the United States, for information.

"And yet, no one railroad was the prototype, exactly, of another. The Baltimore & Ohio Railroad set men to thinking, and gave them the benefit of its experience. But originality was everywhere aimed at; and improvement was the consequence everywhere. The Chevalier Von Gerstner, a distinguished German engineer, who had constructed a short railroad in Russia, from St. Petersburg to Tsarskoseloe, came to America while the railroad fever was at its height, for information, as he said. At this date England was well under way with the system, and the speaker expressing surprise to the Chevalier that he had not remained there, instead of coming to the United States, the latter answered at once: 'That is the very thing I want to escape from—this system of England, where George Stevenson's thumb, pressed upon a plan, is an *imprimatur*, which gives it currency and makes it authority throughout Great Britain; while here, in America, no one man's *imprimatur* is better than another's. Each is trying to surpass his neighbor. There is a rivalry here out of which grows im-

provement. In England it is imitation—in America it is invention. It would take time to illustrate the truth of the assertion of Von Gerstner. It was true when he made it. It still continues true, to a great extent, as regards the two countries.”

The line of the Baltimore & Ohio Railroad over the Allegheny Mountains between Piedmont and Grafton, having grades 17 and 11 miles long, respectively, of 116 feet to the mile, was commenced in 1849 and opened in 1852. The experience thus obtained was, as stated by Colburn, “avowedly consulted by the engineers who laid out the Semmering section of the South Austrian line,” on  $13\frac{1}{4}$  miles of which the average gradient was 112 feet to the mile, with a maximum for  $2\frac{1}{2}$  miles of 132 feet to the mile. “Before commencing the construction of the Semmering Pass of the Southern line, the Austrian Government sent over the engineer of the railway to America to investigate the subject of steep gradients. On his return the surveys were commenced, and the present line along the valley of Reichenau, and through Klamm, etc., was selected.” (*Minutes of the Proceedings of the Institution of Civil Engineers*, Vol. XV, p. 350.) In 1852, the Austrian Government offered prizes for engines suitable for working on this line, which was opened in May, 1854, the locomotives first adopted being those of the Engerth design, in which part of the weight of the engine was carried on the tender frame, and the wheels of the latter were coupled and driven by gearing from the rear engine axle. The operation of these engines was not wholly satisfactory and was not long continued, and they were superseded by others, the general design of which, like that of the location of the road, was based upon successful American practice.

The construction of the Baltimore & Ohio Railroad was commenced July 4th, 1828, by the laying of the “first stone” by Charles Carroll, of Carrollton, one of the signers of the Declaration of Independence, and after doing so he said: “I consider this among the most important acts of my life, second only to my signing the Declaration of Independence, even if it be second to that.” A little more than eighteen months thereafter, *i. e.*, on May 22, 1830, the first division of the road, then extending only from Baltimore to Ellicott’s Mills, a distance of 13 miles, was opened for the transportation of passengers, the cars being hauled by horses and mules. Although the number of cars was very limited, and only one track of the road was completed, the receipts, up to October 1, 1830, four months from the time of putting the cars in regular service, were \$20,012.36.

Shortly after the opening of the road, a new mode of propulsion was proposed by Evan Thomas, of Baltimore, who constructed an experimental car having a *sail*, which he called the "Æolus," and ran upon occasions when there was enough wind blowing in direction to make it available. Among those who observed its operation was Baron de Krudener, the Russian Ambassador, who made a trip on the car, managing the sail himself, and expressed himself as highly pleased with the experience. The President of the Company presented him with a model of the car, to be forwarded to the Russian Emperor, who subsequently sent two officers of the Russian Navy to examine the railroad and its rolling stock. Upon their return to Russia, they made a report which led to the appointment of a delegation to make further examination, and was followed by an invitation to Ross Winans to superintend the construction of machinery for the railroads contemplated by the Russian Emperor. While the sailing car was, as a matter of course, of no practical value, it thus led to the introduction of American machinery, constructed under the superintendence of American engineers, into the Russian Empire.

The practicability and desirability of the use of locomotive engines as motive power were recognized, and their application decided upon, in view of the operation of Peter Cooper's small experimental locomotive before referred to, on a trip from Baltimore to Ellicott's Mills and back, made August 28, 1830, as will be indicated by the following extract from the Fourth Annual Report of the Company, 1830, pp. 33-35:

"Experience, with regard to the celerity of the conveyance of passengers during the preceding four months on the first 13 miles of the Baltimore & Ohio Railroad, is of the most cheerful and convincing character. The practicability of maintaining a speed of 10 miles per hour *with horses* has been exhibited. With proper relays, this rate of traveling may be continued through any length of railway, the ascents and descents of which shall not exceed about 30 feet per mile.

"Within the last few months, the improvements in locomotive steam engines have been such as to insure their general use on all railways of suitable graduation, and where fuel is cheap. The weight of these machines has been greatly reduced and the generation and application of the power so much economized, as to put to rest all comparison between locomotive and stationary power on the Liverpool & Manchester Railway. From the experiments in October last, on that road, with the improved locomotives, as well

as from other trials subsequently made, it has been demonstrated that these machines are capable of maintaining any desirable velocity which the bounds of prudence may warrant, and that such is their celerity and economy of movement, that the facilities of traveling and conveyance upon railways will far transcend those of any other method hitherto known.

“The foregoing view of the subject would appear to indicate the expediency of an early application of locomotive steam power on the Baltimore & Ohio Railroad. Whatever doubts may have been entertained, of the applicability of locomotive engines, on a railway, the curvatures of which have a radius of 400 feet, none can remain, after the recent triumphant demonstration, with an experimental engine, constructed by Peter Cooper, of New York.

“This small engine, with a single working cylinder, of three and a half inches diameter, was placed on wheels 30 inches in diameter which were made for other cars. The wheels being small, gearing was used to give velocity. It worked smoothly, and went to Ellicott’s Mills, 13 miles, with a speed varying from five to 18 miles per hour—propelling before it a car with twenty-three persons. It traversed in half an hour, about four miles in a continued ascent of 13 to 18 feet per mile, and on much of this distance, were curves of 400 feet radius. It returned through the 13 miles in 57 minutes, propelling the car and 30 persons. It run through part of the way, which is level and curved, with a radius of 400 feet, at the rate of 15 miles per hour.”

“This experiment is considered valuable, as indicating that the curvatures of our railroad will not prevent the successful application of the locomotive engine. It will only be necessary to increase the size and power of the engine, and every desirable end will be attained. This engine being too small for advantageous use, no further description of it is deemed necessary.”

A complete and authenticated drawing and a full description of the Peter Cooper engine, which B. H. Latrobe says “was undoubtedly the *very first* American locomotive,” would be of great interest, but neither is in existence. It may, however, be sufficiently understood for present purposes by reference to Fig. 1 and the brief general description given by Mr. Latrobe in a letter dated November 20, 1869, which was endorsed as substantially correct by Ross Winans, who took an active part in the development of the Baltimore & Ohio motive power from its inception up to the year 1857.

Mr. Latrobe's description is as follows:

"Ross Winans tells me that Mr. Cooper brought the boiler from New York, in the spring or early in the summer of 1829; and it was on a frame, and rested on four wheels belonging to the company; the road was then used thirteen miles to Ellicott's Mills, and with horse-power. The boiler was tubular, and upright in position. Mr. Winans does not recollect the dimensions of it, although he says it lay in his shops for several years. He thinks it was not more than twenty inches in diameter, and, perhaps, from five to six feet high. There was a single cylinder of three and one-quarter inches in diameter, fourteen and one-quarter inches

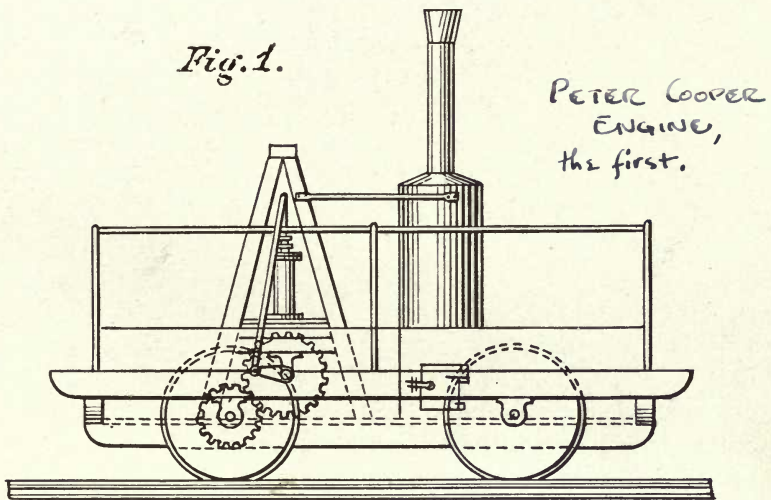

stroke, that projected its piston rod and connecting rod, so as to take hold of the crank by direct action.

"On the crank shaft, which rested on the frame of the car, was a spur-wheel which geared with a pinion on the forward road-wheels so as to increase speed; the road-wheels being only two and one-half feet in diameter.

"The fuel was anthracite coal, and an artificial draught, in the fire-box at the bottom of the boiler, was created by a fan, driven by a belt passing around a wooden drum attached to one of the road-wheels, and a pulley on the fan-shaft as shown in the sketch.

\* \* \* \* \*

"The road-wheels were two and a half feet in diameter; the axles had outside bearings upon Winans' friction wheels. The

axle on which the pinion was fixed was kept from lateral or longitudinal movement, so as to preserve its position with respect to the spur-wheel."

Mr. Winans made a report August 28, 1830, to P. E. Thomas, President Baltimore & Ohio Railroad, of the operation, on that day, of the Peter Cooper engine. In this report, he compared the performance of the engine with that of the "Rocket" on the Liverpool & Manchester Railway in October, 1829, and found that the former "exhibited an average force during the time it was running of 1.43 horse power, or nearly one and a half, which is more than three times as much power as the Rocket exhibited during the experiment above described, in proportion to the cylindrical capacity of the respective engines. This, no doubt, originated in a considerable degree from the steam being used in Mr. Cooper's engine at a higher pressure than in the Rocket."

The above review of the preliminaries to the application of locomotive engines to regular service on the Baltimore & Ohio Railroad may properly be terminated by a quotation of the expressions made by Mr. Winans as to their practicability, in this report, in concluding which he says:

"But to-day's experiments must, I think, establish, beyond a doubt, the practicability of using locomotive steam-power on the Baltimore & Ohio Railroad for the conveyance of passengers and goods at such speed and with such safety (when compared with other modes) as will be perfectly satisfactory to all parties concerned, and with such economy as must be highly flattering to the interests of the company. It has been doubted by many whether the unavoidable numerous short curves on the line of your road and inclined planes would not render the use of locomotive power impracticable; but the velocity with which we have been propelled to-day by steam-power round some of the shortest curves (to wit, from fifteen to eighteen miles per hour) without the slightest appearance of danger, and with very little, if any, increased resistance, as there was no appreciable falling off in the rate of speed, and the slight diminution in speed in passing up the inclined planes, some of which were nearly twenty feet to the mile, must, I think, put an end to such doubts, and at once show the capability of the Baltimore & Ohio Railroad to do much more than was at first anticipated or promised by its projectors and supporters."

The periods of the successive openings of the Baltimore & Ohio Railroad to various points were as follows:

Opened to Ellicott's Mills.....	14 miles, by horse power, 24th May, 1830.
Opened to Ellicott's Mills.....	14 miles, by steam power, 30th August, 1830.
Opened to Frederick .....	61 miles, 1st December, 1831.
Opened to Point of Rocks.....	69 miles, 1st April, 1832.
Opened to Harper's Ferry.....	81 miles, 1st December, 1834.
Opened to Bladensburg .....	32 miles, 20th July, 1834.
Opened to Washington .....	40 miles, 25th August, 1834.
Opened to opposite Hancock.....	123 miles, 1st June, 1842.
Opened to Cumberland .....	178 miles, 5th November, 1842.
Opened to Piedmont .....	206 miles, 21st July, 1851.
Opened to Fairmont .....	302 miles, 22d June, 1852.
Opened to Wheeling .....	379 miles, 1st January, 1853.

The opening of the road to Wheeling was celebrated January 12th, 1853, by a reception and banquet, tendered by the authorities of that city to the President and Directors of the Company, and a number of invited guests, including the Governors of Maryland and Virginia, members of the Legislatures of those States, and others. The following extract from the speech made by Thomas Swann, the President of the Company, on that occasion, correctly indicates the pioneership of the road in the operation of exceptionally heavy grades by locomotive power, and the originality of conception and courage of convictions of those who demonstrated that operation to be both possible and successful:

"The next most interesting epoch in the history of this road was the working of the high grade of 116 feet. We were told the story of a man who had built a mill without first ascertaining where he was to get the water to put it in motion. A road was being constructed at a cost of millions, and we were yet to satisfy the public that we could make it available for locomotive power.

"This road was opened to Piedmont in 1851, when it was thought expedient to test this great problem. There are those present who will not forget that interesting occasion. We left Baltimore with a large company of our municipal authorities and the leading dignitaries of our city. Both the Chief Engineer and myself thought it advisable, if we were doomed to fail in this last effort, that it should be in *good company*. The train having reached the foot of the heavy grade, it was agreed that the Chief Engineer should take his stand upon the engine, where, in the event of discomfiture, he might conceal his shame in the smoke,

in which he would soon be enveloped. I, on the other hand, who was most likely to be held responsible, from the position which I occupied, deemed it convenient to take my stand at an *open door* of the car, with a view to a more *ready access to the woods.*)

“In this situation we commenced the ascent of this heavy grade. It was a moment of intense anxiety—not as to the result, Mr. Mayor, for we knew full well what that result would be; but as to the effect of any casual mishap, from whatever cause, upon those who were so anxiously awaiting the issue. As good luck would have it, however, the iron horse did his duty without faltering—the summit was reached; and the hurrahs of the multitude proclaimed that this last triumph was complete.

“As to the power of overcoming high grades, Mr. Mayor, we claim to have taught a lesson to the world. During the whole of the past summer, this Company carried the United States Mail *over a grade of 530 feet to the mile, without the aid of assistant power*; and every bar of iron which was laid upon the track, between the Kingwood Tunnel and Fairmont, was passed over the same summit. The fact is, Mr. Mayor, I had serious intentions, at one time, of presenting the Chief Engineer of this Company, for uselessly involving us in the construction of tunnels, miles in extent, when he has shown by actual experiment, that he could overcome grades with so little apparent inconvenience.”

The report of William Parker, General Superintendent, presented in the Twenty-sixth Annual Report of the Company, for the year 1852, contains the following statement of new locomotives contracted for and ordered to be built in the Company’s shops since 1850, and is of interest as showing the prices prevailing at that time:

10	Made by Ross Winans, before October, 1851, at \$9,750.	\$97,500
1	Made by the Company.	9,500
21	Since September, 1851, by Ross Winans, at \$9,750.	204,750
1	Made by the Company, at \$9,500.	9,500
3	Made by the Company, at \$9,000.	27,000
25	Contracted for and not yet delivered, by Ross Winans, at \$9,750	243,750
8	do. do. A. W. Denmead, at \$8,500.	68,000
2	do. do. Smith & Perkins, at \$9,500.	19,000
2	do. do. New Castle Manufacturing Co., at \$9,500	19,000
1	do. do. do. do. at \$8,500.	8,500
3	Ordered in Company’s Shops, at \$9,500.	28,500
77	Engines in all, costing together.	\$735,000



"If to these we add 64, the total number of engines previously in service, we shall have 141 as the total locomotive power for the Main Stem, which are reckoned equivalent in power to more than 100 engines of the largest class.

"Of this increased power, it is estimated that about 65 per cent. will be employed West of Cumberland."

---

It would manifestly be impossible to present at this late day a description which would be complete and accurate, of the early motive power of the Baltimore & Ohio Railroad, by which is meant its early locomotives of such designs as have now become either obsolete or modified to such an extent as to be no longer, except in the most general sense, characteristic. Comparatively few drawings of these locomotives were ever made, some of these being the work of the pattern maker on boards, and none can now be found, all of them in the possession of the Machinery Department having been destroyed by order of a former Superintendent of Motive Power, who strangely failed to recognize that while of no pecuniary value, their historic interest should have insured their preservation. Among these drawings the writer remembers a number relating to the "Dutch wagon" crank axle, and "Camel" ten-wheel passenger engines, built during the administration of Samuel J. Hayes, and the ten-wheel engines of Henry Tyson, the last named having been made by the late M. N. Forney. All these were models of good draughting work, and some of them were executed in the old time artistic style, which has now become a lost art. Their destruction is greatly regrettable from the standpoint of the historian, and is without apparent warrant on any ground. Further, there are but very few persons now living who are familiar with the old constructions, and in the lapse of time it cannot be expected that details of them would remain fresh in their recollection.

The Thirty-fourth Annual Report of the Company, dated October 1, 1860, gives, in Table "F," a list of 236 locomotives then owned and in service on the Main Stem, Northwestern Virginia Railroad, and Washington Branch. These included engines of all of the early types, and the writer will endeavor to classify the motive power specified in this Report, and, as far as the data in his possession or accessible to him, supplemented by the recollection of his personal experience in the drawing room of the Machinery Department in the early sixties, will render possible,

to illustrate examples of the different types of locomotives which it comprehends. The classification of types may, it is believed, be most clearly made on the basis of wheel arrangement, and the illustrations of the several types will be presented as nearly in the order in which the examples shown were put in service as this classification permits.

## CHAPTER I.

## THE "GRASSHOPPER" AND "CRAB" ENGINES—TYPE O-4-O.

The unqualified approval of locomotive engines as the motive power of the Baltimore & Ohio Railroad, made by Ross Winans in his report of August 28, 1830, from which we have quoted, and the expression of the expediency of their early application which appears in the Fourth Annual Report of the Company, were promptly followed by action in the line of their introduction, and on January 4, 1831, the Company issued the first proposal for the construction of locomotives which was made in the United States, this being in the form of the following advertisement:

"Office of the  
Baltimore & Ohio Railroad Company,  
4th January, 1831.

"The Baltimore & Ohio Railroad Company being desirous of obtaining a supply of Locomotive Engines of *American manufacture*, adapted to their road, the President and Directors hereby give public notice that they will pay the sum of Four Thousand Dollars for the most approved engine which shall be delivered for trial upon the road on or before the 1st of June, 1831—and that they will also pay Three Thousand Five Hundred Dollars for the engine which shall be adjudged the next best and be delivered as aforesaid, subject to the following conditions, to wit:

"1. The engine must burn coke or coal and must consume its own smoke.

"2. The engine, when in operation, must not exceed three and one-half tons weight, and must, on a level road, be capable of drawing, day by day, fifteen tons, inclusive of the weight of the wagons, fifteen miles per hour. The company to furnish wagons of Winans' construction, the friction of which will not exceed five pounds to the ton.

"3. In deciding on the relative advantages of the several engines, the company will take into consideration their respective weights, power, and durability, and, all other things being equal, will adjudge a preference to the engine weighing the least.

"4. The flanges are to run on the inside of the rails. The form of the cone and flanges, and the tread of the wheels, must

be such as are now in use on the road. If the working parts are so connected as to work with the adhesion of all the four wheels, then all the wheels shall be of equal diameter not to exceed three feet, but if the connection be such as to work with the adhesion of two wheels only, then those two wheels may have a diameter not exceeding four feet, and the other two wheels shall be two and a half feet in diameter, and shall work with Winans' friction wheels, which last will be furnished upon application to the company. The flanges to be four feet seven and a half inches apart from outside to outside. The wheels to be coupled four feet from centre to centre in order to suit curves of short radius.

"5. The pressure of the steam not to exceed one hundred pounds to the square inch; and as a less pressure will be preferred, the company in deciding on the advantages of the several engines will take into consideration their relative degrees of pressure. The company will be at liberty to put the boiler, fire tubes, cylinder, etc., to the test of a pressure of water not exceeding three times the pressure of the steam intended to be worked, without being answerable for any damage the machine may receive in consequence of such test.

"6. There must be two safety valves, one of which must be completely out of the reach or control of the engine man, and neither of which must be fastened down while the engine is working.

"7. The engine and boiler must be supported on springs and rest on four wheels, and the height from the ground to the top of the chimney must not exceed twelve feet.

"8. There must be a mercurial gauge affixed to the machine with an index rod, showing the steam pressure above fifty pounds per square inch, and constructed to blow out at one hundred and twenty pounds.

"9. The engines which may appear to offer the greatest advantages will be subjected to the performance of thirty days' regular work on the road; at the end of which time, if they shall have proved durable and continue to be capable of performing agreeably to their first exhibition, as aforesaid, they will be received and paid for as here stipulated.

P. E. THOMAS, *President.*

"N. B.—The Railroad Company will provide and will furnish a tender and supply of water and fuel for trial. Persons desirous of examining the road or of obtaining more minute infor-

mation, are invited to address themselves to the President of the Company. The least radius of curvature of the road is 400 feet. Competitors who arrive with their engines before the first of June will be allowed to make experiments on the road previous to that day.

"The editors of the *National Gazette*, Philadelphia; *Commercial Advertiser*, New York, and *Pittsburg Statesman* will copy the above once a week for four weeks, and forward their bills to the B. & O. R. R. Co."

No official report of the tests of locomotives which were presented in response to this advertisement would appear to have been made, or if made, to be of record. The earliest published reference to them which the writer has been able to find is contained in the following extract from "*A History and Description of the Baltimore and Ohio Rail Road*," Baltimore, 1853, pp. 31, 32:

"During the summer of 1831, in pursuance of this call upon American genius, made by the Directors, three locomotive steam engines were produced upon the railroad, only one of which, however, was made to answer any good purpose.

"This engine, called 'The York,' was built at York, Pa., by Phineas Davis (or rather "Davis and Gartner"), and after undergoing certain modifications was found capable of conveying fifteen tons at fifteen miles per hour, on a level portion of the road. It was employed on that part of the road between Baltimore and Ellicott's Mills, and generally performed the trip to the Mills in one hour, with four cars, being a gross weight of about fourteen tons. This engine was mounted on wheels like those of the common cars, of thirty inches diameter, and the velocity was obtained by means of gearing with a spur-wheel and pinion on one of the axles of the road wheels. The curvatures were all traveled with great facility by this engine—its greatest velocity, for a short time, on straight parts of the road having been at the rate of 30 miles per hour, while it frequently attained that of 20 miles, and often traveled in curvatures of 400 feet radius, at the rate of 15 miles per hour. The fuel used in it was anthracite coal, which answered the purpose well, but the engine weighing but three and a half tons was found too light for advantageous use on ascending grades.

"The performance of this engine fully confirmed the Board and its Engineer Corps, that locomotive engines might be successfully used on a railway having curves of 400 feet radius, and from that time forward, every encouragement was given by the

Company to the inventive genius of the country to improve on the partially successful experimental engine that had been produced by Mr. Davis."

Benjamin H. Latrobe, formerly Chief Engineer of the Baltimore & Ohio Railroad, gives, in an illustrated article published in *The Railroad Gazette* of March 8, 1873, an interesting account of "the design and construction of that form of the locomotive engine first used some 40 years back [of 1873] for the regular and efficient traction of trains upon the Baltimore & Ohio Railroad, and which has been popularly known as the 'grasshopper engine.'" While the data which Mr. Latrobe presents in this article is not only the fullest which is of record, but is also doubtless approximately accurate, he admits its insufficiency by the statement that "it is indeed to be regretted that the history of a machine of so original and remarkable features should not have been earlier written, and while the facts and circumstances connected with it were fresh in the recollection of those concerned in its production."

Mr. Latrobe's account of the result of the tests corroborates that of the author of the "History" from which quotation has been made above, except as to the *number* of locomotives tested, his statement being as follows:

"Four engines of various models (among them a rotary) entered into the competition; but the only one of the four which proved equal to this moderate performance was that of Davis & Gartner, two machinists of York, Pennsylvania. The performance was not, indeed, accomplished without certain modifications having been first made in the machine, as mentioned by the late Jonathan Knight, then Chief Engineer of the Company, in his annual report of that year."

Fig. 2 is a reproduction of a diagrammatic sketch of the "York," which appeared in Mr. Latrobe's paper, and which he stated was prepared by him with the assistance of Ross Winans, who was, at the time the engine was placed on the road, Assistant Engineer of Machinery. The characteristic features of the "York," *i. e.*, the vertical boiler and cylinders, with connections to trussed horizontal bars coupled to cranks on the axles of the four wheels, were said by Mr. Latrobe to be "novel and ingenious," but the engine "worked badly in consequence of the action of the springs due to the inequalities of the track and the alternating vertical movement of the pistons." There were no tubes in the boiler, and a pipe extended downward from the crown-sheet to a flat cylindrical drum called a "cheese." Mr. Latrobe said that "the 'cheese'

boiler was perhaps retained in the 'York,' but the cylinders must have been removed from their position on each side of it and placed in front so as to connect with the spur and pinion on the axle of the road wheel, instead of the trussed side bars above mentioned." The dimensions of the "York" were not specified by Mr. Latrobe, further than that its wheels (cast iron) were thirty inches in diameter and that it weighed only three and one-half tons, and no fuller or more detailed description than that given by him has been found by the writer.

Mr. Latrobe further says that after working a while, the "York" was laid aside and another engine, the "Atlantic," was

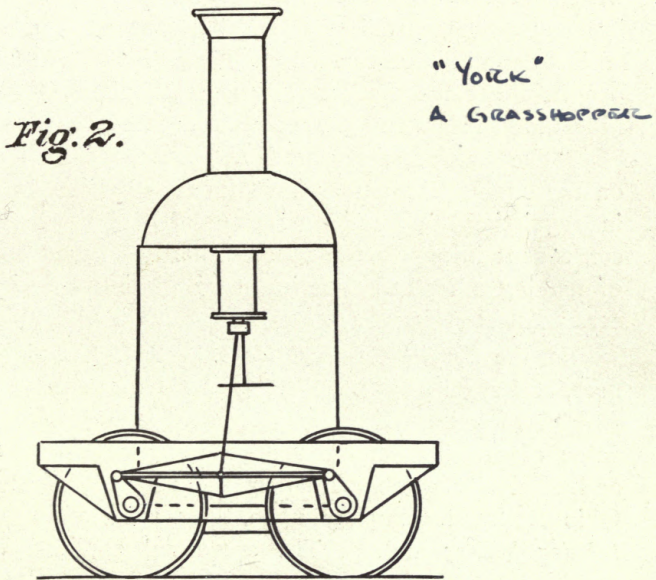

placed on the road about September 1, 1832. This, he says, "was the first 'grasshopper' engine, although not the full-fledged machine to which that apt yet somewhat grotesque sobriquet was subsequently, and ever since, applied." Particulars of the "Atlantic" appear in the Sixth, Seventh and Eighth Annual Reports of the Company, 1832, 1833 and 1834, from which the following excerpts are made:

"A new locomotive engine of enlarged dimensions and capability has, however, been constructed and placed upon the Baltimore & Ohio Railway, by Davis & Gartner, who, profiting by their

first successful attempt, have, in this instance, completely succeeded in combining in the new locomotive all the requisite efficiency, as regards capacity and motive power.

"This engine, denominated the 'Atlantic,' has undergone the test of one month's continuous use in the transportation of all the passengers traveling between Baltimore and the inclined planes at Parr's Ridge, a distance of 40 miles, making 80 miles each trip, going and returning daily.

"The fuel used is exclusively anthracite coal." *Sixth Annual Report*, 1832, pp. 48, 49.

The weight of the "Atlantic" is given in this Report as  $6\frac{1}{2}$  tons, about  $\frac{3}{5}$  or 4 tons of which was on "the two traveling wheels or road wheels," which were 3 feet in diameter, driven by spur gearing from engines. The diameter of the driver was 28 inches and pinion 14 inches. The cylinders were 10 x 20 inches.

In the same Report, George Gillingham, Superintendent of Machinery, refers to his appointment on March 1, 1832, and says:

"The experiments that have been made on the steel springs on the engine and tender have furnished evidence of their utility in regulating the motion, and greatly diminishing the jar and consequent injury to the road. This has suggested the propriety of making a farther experiment by placing a few of the burden cars on steel springs" (p. 110).

In the *Seventh Annual Report*, 1833, J. Knight, Chief Engineer, states, on p. 35:

"Two points of great interest, therefore, in relation to the value of steam locomotion upon railways have been determined and efficiently combined under the auspices of the Baltimore & Ohio Railroad Company upon their road, viz.: 1. *The upright tubular boiler*; and, 2. The successful application of anthracite coal."

George Gillingham, Superintendent of Machinery, refers to the "Atlantic" as having run 13,280 miles and burned 190 tons of coal at \$8 per ton.

The *Eighth Annual Report*, 1834, gives the following dimensions of the "Atlantic":

Boiler, upright, 51 inches diameter and 69 inches in height above grate. Diameter fireplace,  $46\frac{1}{2}$  inches; height, 22 inches. Tubes, 282 in number; diameter at lower end,  $1\frac{1}{2}$  inches; at upper end, 1 inch; 16 inches long. Smoke box,  $46\frac{1}{2}$  inches diameter; height, 6 inches. Stack, 13 inches diameter and 14 feet 6 inches above rail. Cylinders, 10 x 20 inches. Road wheels, 35 inches



diameter; engine geared, 28 x 14 inches, to one pair only. Fan blast.

Mr. B. H. Latrobe states that the steam pressure employed in the "Atlantic" was ordinarily 50 pounds, and the cost of the engine was believed to be about \$4,500.

The next engine placed on the road was the "Indian Chief," which came out of Davis & Gartner's shops at York, under the name of the "Traveller," in October, 1833, regarding which the same Report states that the pinion was placed on a separate axle, about three feet forward of the front axle, and carrying cranks coupled by connecting rods to cranks on the two road axles.

"The side pieces of the frame of the 'Traveller' are plated with rolled iron; the bearing boxes work in slides; and the springs are placed above the boxes and underneath the side pieces; arrangements that are superior to those of similar parts in the 'Atlantic' engine."

The third engine succeeding the original "York" was the "Arabian," placed on the road in July, 1834. Regarding this engine, the *Eighth Annual Report* states that the boiler was similar to those of the "Atlantic" and "Traveller," except in number and dimensions of tubes, their arrangement with that of the upper part of the boiler, and a slight change in the dimensions of the latter. Diameter of boiler, 52 inches; height, 64 inches; 400 tubes; diameter at lower end,  $1\frac{1}{4}$  inches; at upper end, 1 inch. Length of tubes, 31 inches, six or seven inches of which is above the water level. Cylinders, 12 x 22 inches; all four wheels coupled.

"In the 'Traveller,' the springs are underneath the side pieces of the frame, but in the 'Arabian' this fixture is improved, the springs being now placed above the frame, as in the English plan. The valve gear for reversing motion has likewise been advantageously modified in the 'Arabian,' being now such that the effort applied to shift the cam frames from one cam to the other operates simultaneously and alike upon both ends of the frame, effecting the object with more certainty and despatch. Improvements have, moreover, been made in the fastenings, connections, and rubbing parts of these machines, at once securing to the new engine superior stability and duration."

The Eighth Annual Report gives the weight of the 'Arabian' as  $7\frac{1}{2}$  tons, 3 tons and 17 cwt. of which was on the forward axle and 3 tons and 13 cwt. on the after part, and refers to feed water heating in a belt around the boiler and fan operated by exhaust steam, as having been patented by P. Davis. This statement is,

however, incorrect, so far as relates to feed water heating, as the only patent to Phineas Davis relating to these engines—that granted to him July 29, 1834, which is for “Promoting the Combustion of Anthracite in Locomotives and other Steam Engines”—describes, shows and claims only the fan blower. The claim of this patent is as follows:

“What I do claim is the combination and arrangement of the parts such as I have described, by which the waste, or escape steam, is made to act upon vanes revolving within a drum, for the purpose of giving motion to wind wheels, to feed the furnaces of steam engines.”

The report of George Gillingham, Superintendent of Machinery, dated October 1, 1834, states that the locomotives then on the road were: First, “Atlantic”; second, “Traveller”; third, “Arabian”; fourth, “Mercury,” all of which were built by P. Davis.

The “Arabian” and the subsequent so-called “grasshopper” engines are shown in Fig. 3, which is reproduced from an advertising lithograph issued by Gillingham & Winans. A similar illustration, except as to the shading, will be found in the first edition of *Stevenson's Civil Engineering of North America*, London, 1838. Engines Nos. 1 (“Arabian”), 2 (“G. Washington”), 3 (“T. Jefferson”), 4 (“J. Madison”), 5 (“J. Monroe”), 6 (“J. Q. Adams”) and 7 (“A. Jackson”), specified in the Thirty-fourth Annual Report, are believed by the writer to have been of the “grasshopper” type, and to be correctly shown in Fig. 3, from which it will be seen that their characteristic features were the vertical tubular boiler, the vertical cylinders operating pivoted lever beams, the main driving shaft geared to a countershaft coupled to the two axles, and the fan blower rotated by the exhaust steam.

George Gillingham, Superintendent of Machinery, states, in the Ninth Annual Report, October 1, 1835, that “there are now in actual service upon the road seven locomotive engines.” The report refers to the “Arabian,” “George Washington,” and “new engine,” and states that “all the engines, the performances of which have been noticed, were constructed by Davis & Gartner, at the Company’s workshops, in this city, and the fuel consumed was, and continues to be, anthracite coal.”

Ross Winans, whose report on the Peter Cooper experimental engine has been referred to, and who was, as appears by the Fifth Annual Report, 1831, an “assistant of machinery” to Jonathan Knight, Chief Engineer, subsequently, in connection with

George Gillingham, engaged in the manufacture of locomotive engines and railroad machinery for the Company, under conditions apparently different from those obtaining then or thereafter in the practice of other railroads, and which are stated in the Tenth Annual Report, 1836, as follows:

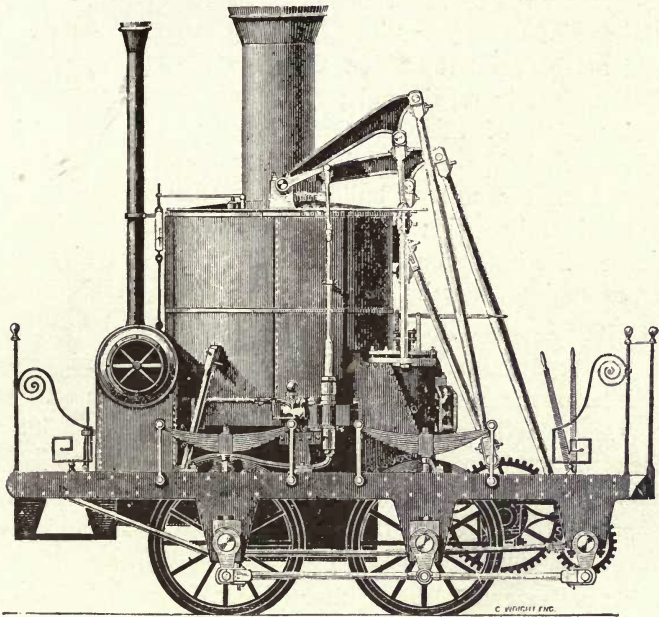

THE BALTIMORE & OHIO LOCOMOTIVE ENGINE,

As Manufactured by Gillingham & Winans, B. & O. R. R. Company's Mt. Clare Depot, Baltimore, Md.

"The characteristics of this engine are: 1. The use of anthracite coal as fuel. 2. The vertical tubular boiler. 3. The use of adhesion of all four wheels. The boiler is competent to supply steam to work up to the adhesion of all the wheels at the rate of ten miles an hour, or to produce a continuous horizontal pull of 2,322 lbs. equal to drawing 211 tons on a level road at the rate of ten miles an hour, as determined from actual experiment. See 9th Annual Report of B. & O. R. R. Co., p. 79. This engine has drawn, exclusive of its own weight, 17½ tons up an ascent of 200 feet per mile for 2,150 feet at the uniform rate of 6 miles per hour. See Report of Committee of City Council of Baltimore, March 24, 1836. The weight of this engine varies from 7 to 8½ tons."

Fig. 3. A GRASSHOPPER

"Since the death of Phineas Davis, mentioned in the last annual report, Messrs. Gillingham and Winans have taken the Company's shops, at the Mount Clare depot, and continue there the manufacture of locomotive engines and railroad machinery commenced by Mr. Davis. Within the last year, the force employed by them has been considerably increased; a circumstance much to the interest of the Company, as it furnishes the means of a prompt compliance with the wants of the road, and when

this is extended westward, will insure a supply of locomotive power and the various necessary machinery, as fast as it is wanted. It may be observed here that the workshops at the Mount Clare depot are carried on by Messrs. Gillingham and Winans, independent of the Company. They are bound by contract to supply the Company with locomotive engines, and all other railroad machinery, at a stipulated price, and at all times to give precedence to the Company's demands for work. They have the use of the ground and buildings occupied by them, with the fixed machinery left by Mr. Davis, without rent, being bound to keep the same in repair and return them as they received them. In consideration of this, they manufacture the Company's engines so much below the market price for them elsewhere that the interest on the cost of buildings and fixed machinery, above mentioned, is fully paid; and, indeed, it would take but a little while, when the extension of the road westward required a larger number of engines, to reimburse to the Company the entire outlay for the shops at the Mount Clare depot." (p. 10.)

In this report, Mr. Knight, the Chief Engineer, says:

"Hitherto the cylinders of this kind of locomotive engine [the 'grasshopper'] have occupied a vertical position; but a plan has been matured to place and work them horizontally. Two engines with horizontal cylinders are being built at the Company's shops, and it is expected that they will have some advantages over former engines." (p. 22.)

The plan referred to was that of Mr. Winans, who, on July 29, 1837, obtained U. S. Patents Nos. 305, 307, 308, 309 and 311, covering various features of his design, which, substantially as put in service on the road, is quite fully and clearly illustrated in the drawings of the patents. The engines of this plan, while similar in many particulars to their immediate predecessors, the "grasshoppers," were thought to be different enough from them to be entitled to another designation, and were known as "coal crabs."

The Fourteenth Annual Report, 1840, states that: "In 1837 there were thirteen old locomotives; such of these as were capable of being repaired have been thoroughly refitted and in some instances entirely renewed, and eleven new engines for the use of the Main Stem have been purchased" (p. 5). From this report, and from Table E of the Twenty-second Annual Report, 1848, engines Nos. 8 ("J. Hancock"), 9 ("P. Davis"), 10 ("G. Clinton"), 11 ("M. Van Buren"), 12 ("B. Franklin"), 14 ("W. Patterson"), 15 ("I. McKim") and 17 ("Mazeppa") appear to

have been "coal crabs." The leading and novel features of this type of engines, which are shown in Figs. 4, 5, 6 and 7, reproduced from the drawings of the Winans Patent No. 308, are specified in the claims of this and the other patents of the same date above referred to, which are as follows:

No. 305. "The leading difference between the side piece

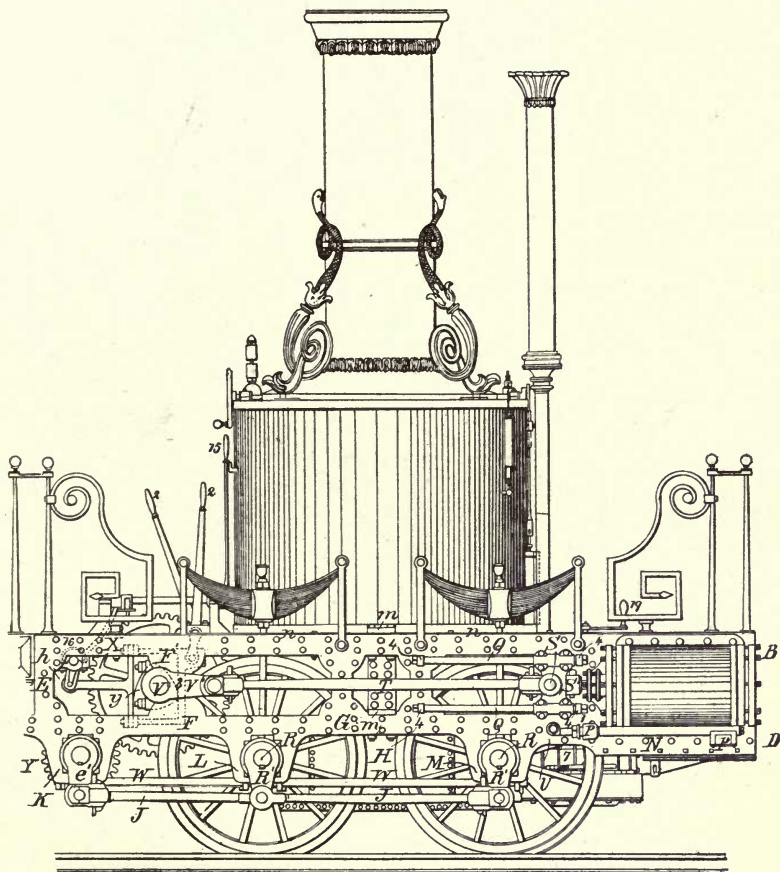

Fig. 4. A CRAB

here described and that heretofore used, and which constitutes the novelty and ground of claim for a patent in this case, is the use of a double rail of wood (instead of a single one) as herein particularly set forth, framed together by cross or upright pieces and plated on each side with iron in continuous sheets, so formed as to receive the cylinders, by which most convenient and per-

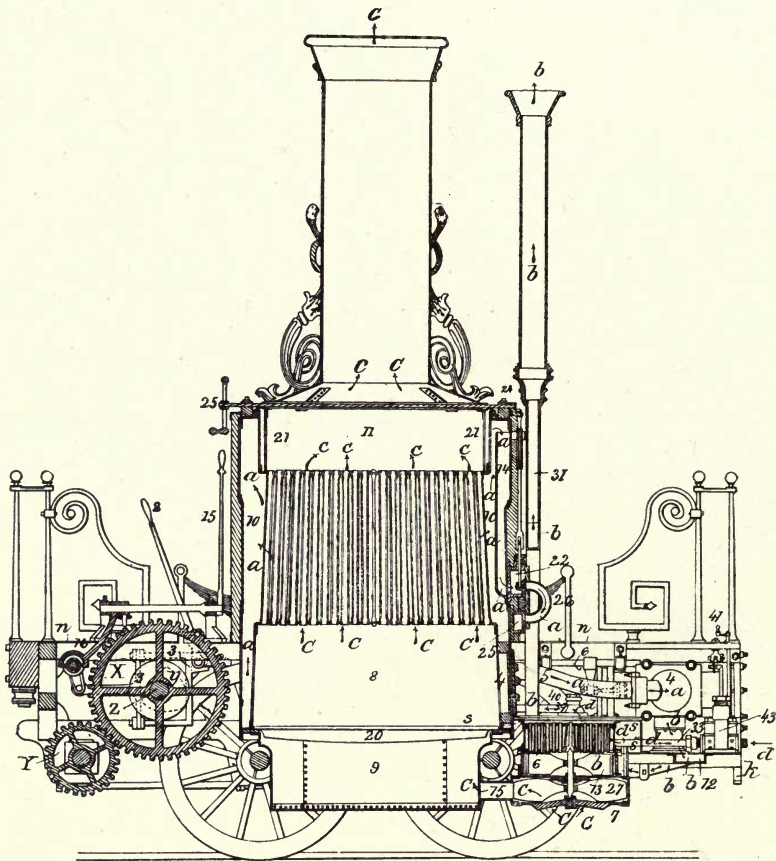

Fig. 5.

continued with  
the engine of the  
Baltimore & Ohio R.R.  
The engine of the  
Baltimore & Ohio R.R.  
The engine of the  
Baltimore & Ohio R.R.  
The engine of the  
Baltimore & Ohio R.R.

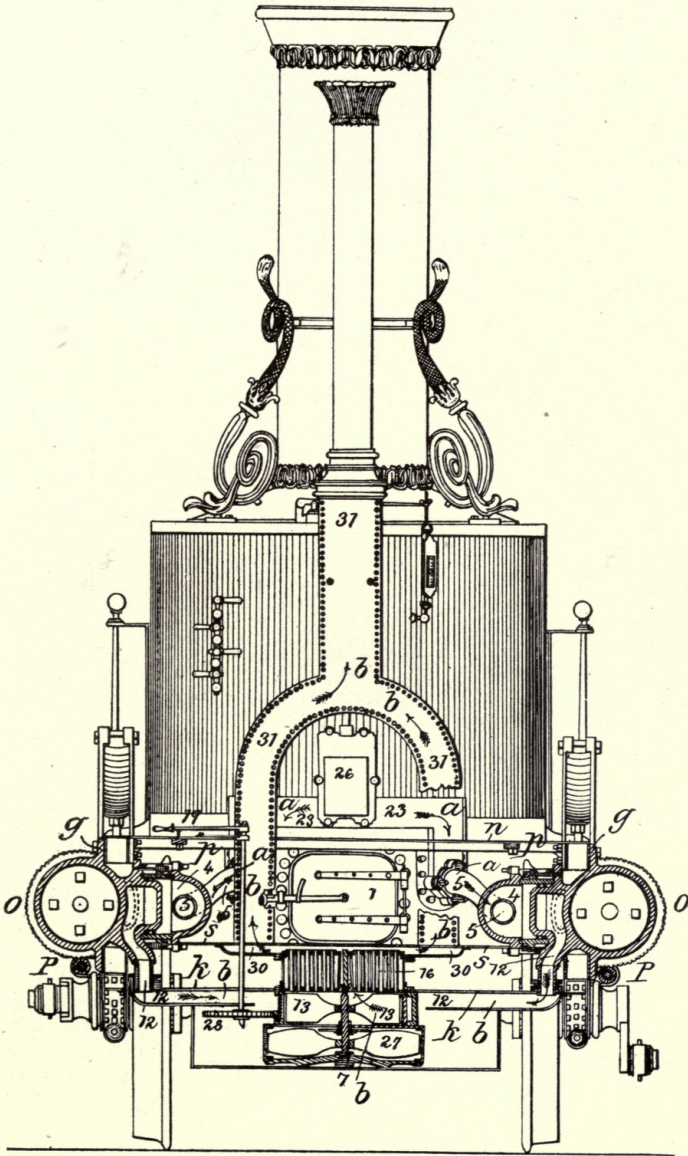

Fig. 6.

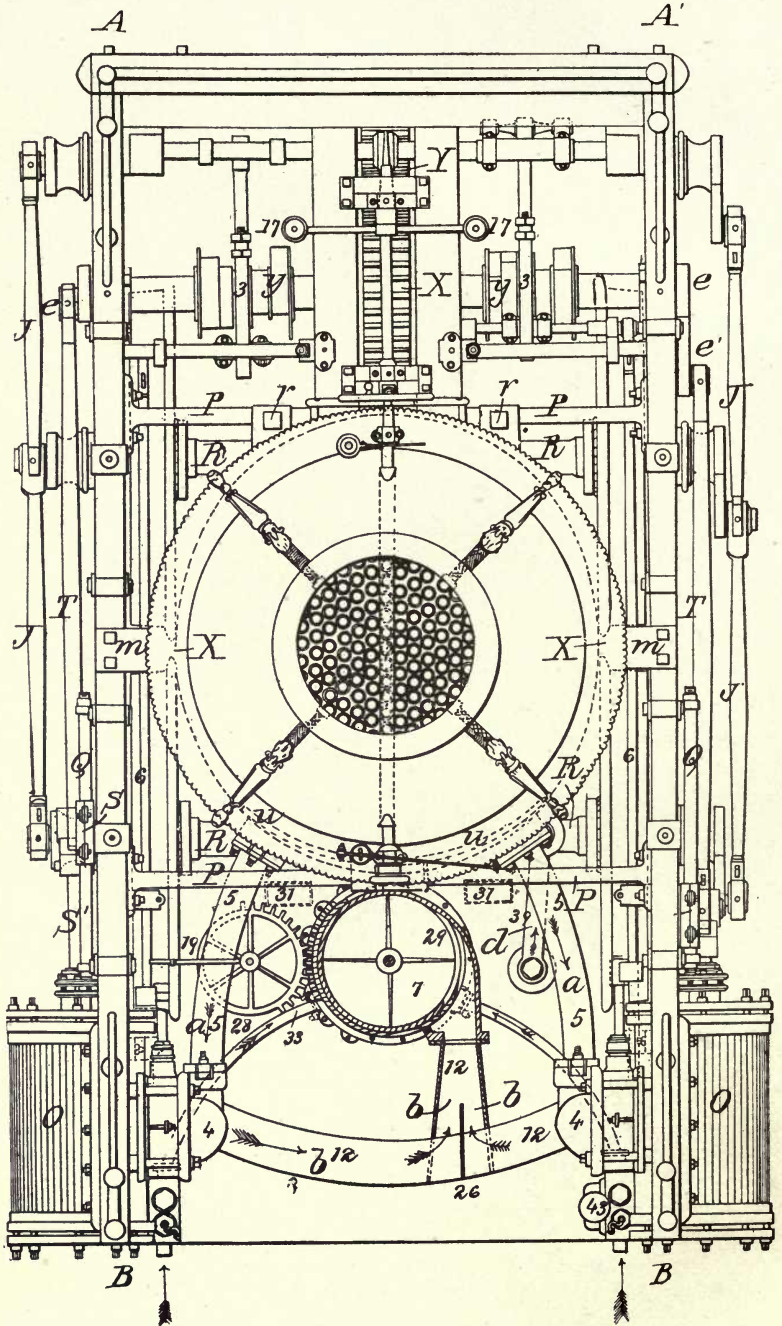

Fig. 7.



manent attachment is furnished for the cylinders and slide rods, and at the same time much greater strength and stiffness are obtained in the side piece in proportion to the material used, than in the ordinary mode of constructing the side piece with a single rail."

No. 307. "First, the varying, increasing and regulating the blast created by the fan wheel by contracting or enlarging the passage, or aperture, through which the steam issues on to the fan wheel substantially in the manner and for the purpose described. This expansion and contraction of the passage may be effected in various ways besides the one set forth, but while the same effort is obtained by analogous means, it will be manifest that the principle of my invention is adopted.

"Secondly, I claim the placing of the steam and fan wheels upon an upright shaft, and the arrangement of the different parts in conformity therewith as herein described, which enables me to combine the steam and fan wheels in a convenient and compact form for the use of locomotive engines.

No. 308. "What I claim as new and for which I ask an exclusive privilege is: First, the combination of the vertical boiler herein described with the horizontal position of the cylinders.

"Second, the combination of the vertical boiler and the horizontal position of the cylinders, or the horizontal position of the cylinders alone, with the spur and pinion wheel and shaft or third axle as above described.

"Third, the arrangement of the machinery generally and combination of its several parts, producing the engine above described.

"I am perfectly aware, that the vertical boiler is not my invention, neither is the horizontal position of the cylinders, but the combination of the boiler herein described, with the horizontal cylinders, so as to obtain the respective advantages of each in the same machine, I believe to be my invention and new, and I therefore claim this combination.

"I am also aware that the spur and pinion wheel shafts have been used before in combination with a vertical boiler and vertical cylinders, but never in combination with a vertical boiler and horizontal cylinders combined; such combination I believe to be my invention and new, and I also claim it as also the combination of spur and pinion wheel shafts, with horizontal cylinders, whether the boiler used be vertical or horizontal, which combination I believe to be my invention and new. Engines may be made of various proportions on the above plan. The dimensions,

I at this time prefer, are those represented in the accompanying drawings, which are drawn to a scale of three-quarters of an inch to a foot.

*No. 309.* "What I claim as my invention and desire to secure by Letters Patent is the heating of the feed water in its passage from the supply pump to the boiler by means of an apparatus substantially the same with that herein described.

*No. 311.* "First—The connection of the power to four or more wheels and the use of much larger cylinders than usual in proportion to the weight of the engine, expressly with a view to and in combination with the cutting off the steam at different portions of the stroke of the piston, by means of which arrangement and combination the object, before stated, of adapting locomotive engines more perfectly to undulating and curved roads, to heavy and light loads, and to slow and fast speed, than heretofore has been effected.

"Second—The use of two or more cams operating on the slide valves, admitting the steam immediately to the cylinders for the purpose of cutting off the steam at different portions of the stroke of the piston as before described, thereby economizing the steam, and consequently the fuel, and better adapting the engine to the duty it may have to perform with different loads on varying curves of the road.

"The use of several cams or of any cam so constructed as to perform the office of several, as hereinbefore described, I believe to be new in itself, separate and apart from the combination herein claimed, and applicable to every species of locomotive engine with advantage and as such I claim a patent for it. The cutting off the steam at a portion of the stroke by a cam operating on the slide valve has been long known and used on locomotive and other engines; but the change in the time of cutting off the steam as described herein and thus being able to work the engine at full, half or other stroke, at pleasure, while the engine is in motion, has not been done by a cam or cams operating on the same valve. An arrangement has been used for cutting off the steam at some one portion of the stroke and changing from that to full stroke at pleasure while the engine was in motion similar to that practiced in most of the steamboats of the present day, by having a throttle or separate valve moved by a cam, or eccentric, or crank and so arranged as to cut off the steam at a portion of the stroke when desired. This, however, does not interfere with either of my claims, inasmuch as my second claim is for a mode

of effecting the cut-off by means of the same valve that admits the steam to the cylinders, and not a separate valve. Neither does it interfere with my first claim, inasmuch as the cutting off the steam and working it at full stroke at pleasure has not been done in combination with the arrangement of connected wheels and large cylinders as herein described, and which arrangement in combination with the cutting off the steam as here described is of the utmost importance in effecting the object of my invention, to wit: the adaption of the locomotive engine to undulating and curved roads more perfectly than heretofore, or to roads where desirable variation in the power of the engine is required."

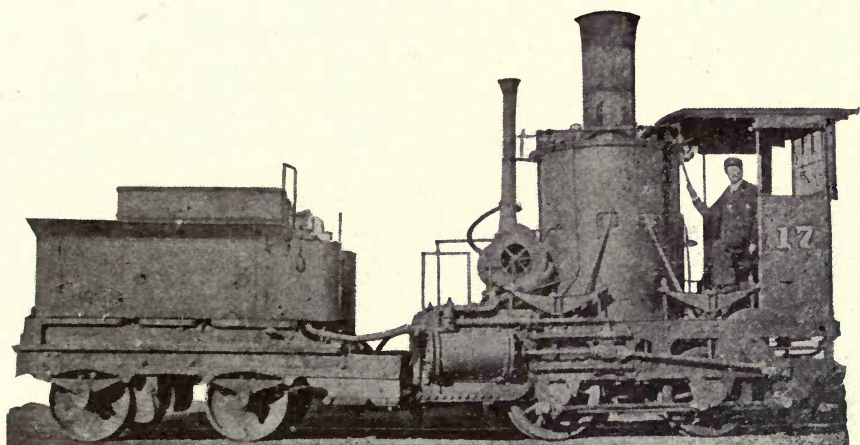

Fig. 8. A CRAB

As shown in Fig. 8, these engines had small cabs on their front ends and were provided with four-wheeled tenders of small size. The blast and fan wheels were fixed on horizontal, instead of vertical shafts as in the patent drawings, and the exhaust steam was passed through a feed water heater between the blast and fan wheels before being discharged into the atmosphere through the open exhaust pipe. In performance reports of the Machinery Department, the cylinders are stated to be  $12\frac{1}{2} \times 24$  inches and  $12\frac{1}{2} \times 28$  inches, in different engines, and the diameter of driving wheels, 36 inches, but the weights and other dimensions are not given in these reports and do not appear to be of record.

While the designs of the "Grasshopper" and "Crab" engines did not present features that were found to be of sufficient value

or importance to be perpetuated in modern practice, they are worthy of permanent record and commendation, by reason of their absolute and characteristic originality and novelty, and the radical departure that was made in them from the English prior art. They fully justified the assertion of Chevalier Von Gerstner that "in England it is imitation—in America it is invention," and were, in some particulars, the basis of later improvements, first developed and applied on the Baltimore & Ohio Railroad, the principle of which, unchanged except as to structural details and proportions, has been retained in the modern American locomotive, and in recent years, largely adopted in European practice.

## CHAPTER II.

## THE "ONE-ARMED BILLY" ENGINES—TYPE 4-2-0.

Zerah Colburn, on pages 43 and 44 of his admirable work, "*Locomotive Engineering*," London, 1871, makes the following acknowledgment of the originality of American engineers in improvements in locomotive construction, and all those which he specified were applied in the locomotives of the Baltimore & Ohio Railroad:

"The English engines served as models from which the American makers copied largely—in the case of the Locks & Canals Company minutely—but it must be owned that, in certain instances, the Americans added original improvements of their own: These were the 'bogie,' the use of four fixed eccentrics, the spark arrester, separate expansion valves, compensating levers between the springs of coupled engines, etc."

Four fixed cams (the equivalent of eccentrics) were used in the "Grasshopper" and "Crab" engines, and the four-wheeled leading truck, or "bogie," as it was termed in England, was the next novel feature that was adopted by the Baltimore & Ohio Railroad Machinery Department. This improvement, of which it may properly be said that it is one of the most important and valuable contributions that has ever been made to locomotive engineering, was devised and first applied to a locomotive by John B. Jervis, a civil engineer who was then and thereafter prominent in his profession. He describes its introduction in his treatise, "*Railway Property*," Philadelphia, 1866, pages 159 and 160, as follows:

"After devoting a good deal of labor to this subject, I prepared a plan, which it is hardly necessary to describe at this time, as it is in general use in the locomotives of this country. This plan, in its general features, had a guiding truck, or a four-wheeled car, arranged as best adapted for following curves on the rail, and keeping on the track, and, at the same time, supporting steadily the forward end of the engine frame. The plan of the engine was prepared in the fall of 1831, and sent to the West Point Foundry Association, who built the engine, and it was placed on the track of the Mohawk & Hudson Railway in the summer of 1832. The working of this engine (named the "Brother Jonathan") satisfied me that the truck principle would be successful, though the engine

was not so in other respects, the attempt having been made to adapt the boiler to the use of anthracite coal, and this required to be changed, which was done the following winter. I then prepared a new plan for an engine for the Saratoga & Schenectady Railway, following substantially the same plan, except as to the boiler, and sent it to George Stephenson, Esq., of Liverpool, who constructed the engine, and it was placed on the Saratoga & Schenectady Railway early in the following summer (1833)."

The merits of the swivelling truck, which was never patented by Mr. Jervis, were at once recognized, and the improvement applied, by builders and users of locomotives in the United States, among the earliest of whom were William Norris and Matthias W. Baldwin, each of whom began the manufacture of locomotives in Philadelphia in 1832, their engines being, for some years, all built with a four-wheeled leading truck and a single pair of driving wheels. In the Norris engines, the driving axle was placed in front of the firebox, and in the Baldwin engines behind it. As a result, the Norris engines possessed greater adhesion and tractive power, while the Baldwin engines were steadier in operation, owing to their longer wheel base. This advantage of the Norris engines, together with the then unparalleled performance of one of them, in 1836, doubtless led to their being preferred by the Baltimore & Ohio Railroad Co., and eight of them, which were built by William Norris, for the road, next followed the "Crabs."

The performance referred to was that of the engine "George Washington," and was made on the inclined plane of the Columbia Railroad, near Philadelphia, July 10, 1836. Zerah Colburn says that "in 1836 such a feat as was achieved by the George Washington took the engineering world by storm, and was hardly credited." It is not believed that any drawing of this engine was ever published, but it is reported as having cylinders  $10\frac{1}{4} \times 17\frac{5}{8}$  inches, a single cranked axle with 4-foot driving wheels, and a four-wheeled leading truck with 30-inch wheels, and as weighing 14,930 pounds, of which 8,700 pounds was on the driving wheels. It hauled a load of 31,720 pounds up the plane, which was 2,800 feet in length, with a grade of 369 feet to the mile, or 1 in 14, at the speed of  $15\frac{1}{2}$  miles per hour. (*American Railroad Journal*, July 30, 1836.) As demonstrated by Colburn, this performance was not possible with the reported weight on the driving wheels and steam pressure of 60 pounds, as assumed by him, but the pressure is reported as "less than 80 pounds," and the statement has been made that a portion of the weight of the tender was put on

the driving wheels by a primitive form of traction increaser. In any event, however, such operation of a locomotive was a remarkable one, particularly so at its early date.

The first of the Baltimore & Ohio Norris engines was the "Lafayette" (No. 13), which was placed on the road in April, 1837, and was followed by the "P. E. Thomas" (No. 16), June, 1838; "J. W. Patterson" (No. 18), October, 1838; "Wm. Cooke" (No. 19), December, 1838; "Patapsco" (No. 20); "Monocacy" (No. 21), July, 1839; "Potomac" (No. 22), August, 1839, and "Pegasus" (No. 24), November, 1839. As appears from the Twenty-second Annual Report, 1848, the "P. E. Thomas" was rebuilt to a 4-4-0 type. These engines were known, among the railroad men, as "one-armed Billys," a sobriquet derived from the single connecting rod and the name of the builder, and their characteristic features are shown with substantial accuracy in Fig. 9. Some of them were in service on light local passenger trains as late as 1857.

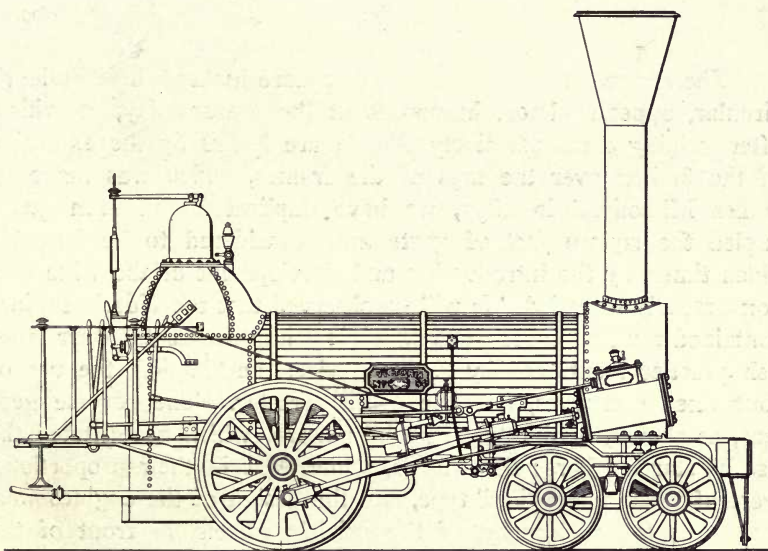

Fig. 9. 'ONE-ARMED BILLY'

The cylinder dimensions of engines Nos. 20, 21 and 22 are given in some of the early "Performance Reports" of the Machinery Department as  $10\frac{1}{2} \times 18$  inches, and of No. 16 as  $10 \times 20$  inches. No other particulars specifically referring to these engines have been found by the writer, but it is probable that they

were practically the same as those given of the Class "B" engines in the following schedule, which is taken from a circular issued by the Norris Works, January 1, 1841:

<i>Dimensions</i>	<i>Class A Extra</i>	<i>A</i>	<i>B</i>	<i>C</i>
Diameter cylinder .....	12½"	11½"	10½"	9"
Stroke .....	20"	20"	18"	18"
Total length of boiler.....	14' 6"	13'	13'	12'
Length of tubes.....	9'	8'	8'	7'
Number of tubes.....	97	97	78	58
Diameter of tubes.....	2"	2"	2"	2"
Grate area (sq. in.).....	1,365.3	1,137	1,050.8	917
Diameter stack .....	13"	13"	10"	10"
Diameter drivers .....	4'	4'	4'	4'
Weight, running order.....	29,630 lbs.	24,100 lbs.	20,615 lbs.	15,705 lbs.
Weight, on drivers.....	20,100 lbs.	16,850 lbs.	12,781 lbs.	8,022 lbs.

The statement of grate area in "square inches," in a builder's circular, appears almost humorous at the present day, at which, after gaining a comparatively few square *inches* by the extension of the firebox over the tops of the frames, which was made by James Milholland in 1857, we have duplicated and even quadrupled the square *feet* of grate area considered to be large in olden times, by the introduction and development of the wide firebox properly so called. It will be observed that the Norris engines contained the first three of the "original improvements" over English practice mentioned by Colburn, viz.: the "bogie," the use of four fixed eccentrics, and the spark arrester. The reverse gear was, as shown, of the "drop hook" pattern, which necessitated the use of starting bars; the frames, while light in their proportions, were of the modern "bar" type, and the design of the engines was, except as to the location of the driving wheels, in front of the firebox, practically followed in all particulars in subsequent practice, during the period in which this type continued to be built. The engines gave as good service as was within the limits of their capacity, which being soon found insufficient to meet transportation requirements, no more of this type were placed on the Baltimore & Ohio Railroad, and, as early as September, 1839, the four-coupled engine with four-wheeled leading truck, or 4-4-0 type, which will next be considered, was introduced.



## CHAPTER III.

## THE GENERAL SERVICE PASSENGER ENGINES—TYPE 4-4-0.

The advantages of the swivelling truck, and, indeed, the *necessity* of its use in service at comparatively high speeds, have never been questioned, but the attendant disadvantage of the resultant reduction in weight available for adhesion, immediately became apparent and serious, and the remedy, which would seem self evident, of increasing the weight of the engine and using an additional pair of driving wheels, appears to have been first proposed by Henry R. Campbell, of Northern Liberties, Philadelphia, to whom a patent, broadly covering what is now known as the 4-4-0 type, was granted February 5, 1836, the claim of this patent reading as follows:

“What I claim as my own invention and not previously known

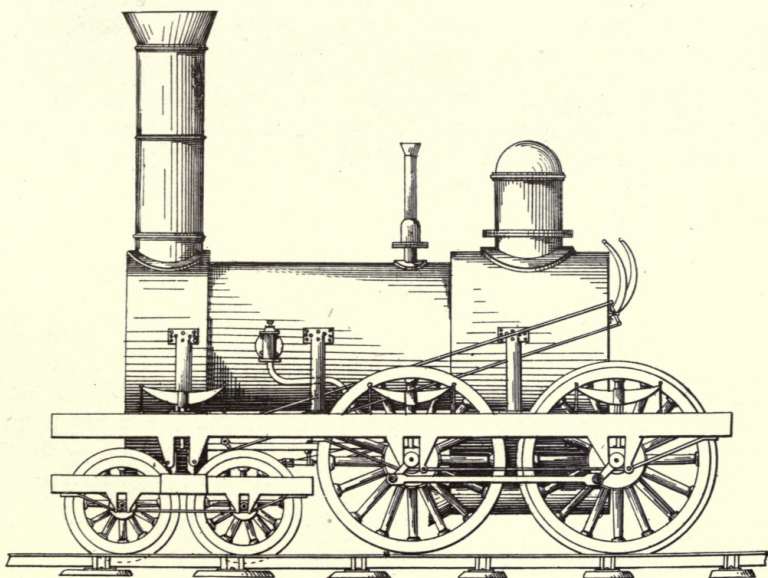

Fig. 10.

in the above described machine is the combination and application to each Locomotive Steam Engine of two pair of Driving or pro-

PELLING wheels and two pair of Guide Wheels and also as a modification and part of my improvement I claim the combination and application to each Locomotive Steam Engine of two pair of driving wheels and one pair of guide wheels for the purposes hereinbefore described."

Fig. 10 is a reduced reproduction of the drawing of the Campbell patent, which illustrates a design corresponding, except as to wheel arrangement, with the then ordinary English practice.

The Campbell design was manifestly defective in its failure to provide for the proper accommodation of the portions of the weight borne by the two driving axles to the inequalities of the track, and this defect was effectually remedied by the next radical improvement in locomotive construction, which is one of the list of American "original improvements" given by Colburn, *i. e.*, the now universally adopted "equalizing lever" between the driving axles. This was the invention of Joseph Harrison, Jr., of Philadelphia, and was covered by his Patent No. 706, dated April 24, 1838, sheet 2 of the drawings of which is reproduced in Fig. 11.

In the form shown in Fig. 1 of this drawing, the spring is hung midway between the driving axles and itself acts as an equalizer, the arrangement being such that, as stated in the specification of the Harrison patent, "the two wheels on each side may readily adapt themselves to the inequalities of the road without altering their relationship to the action of the spring." The construction shown in Fig. 2 differs from that of Fig. 1 only in the location of the spring above, instead of below, the frame, and in Figs. 3 and 4, the equalizing lever, or "vibrating beam" as it was termed by Harrison, is combined with the spring, the effect of which arrangement, in equalizing the bearing of the wheels, was, as stated by him, "the same with that produced by the two former." Claim 2 of the patent covers "a vibrating beam or any analogous contrivance connected and arranged to produce the same effect," *i. e.*, that of springs vibrating upon their centres.

While the form in which the Harrison "vibrating beam" was latterly and is at present used, that is to say, with the ends of the equalizer interposed between and connected to the hangers of two adjacent driving springs, is not shown in the drawings of the Harrison patent, it is obvious that the same operative principle is embodied as in the forms therein shown, and Mr. Harrison's improvement is one that is indispensable in standard American practice.

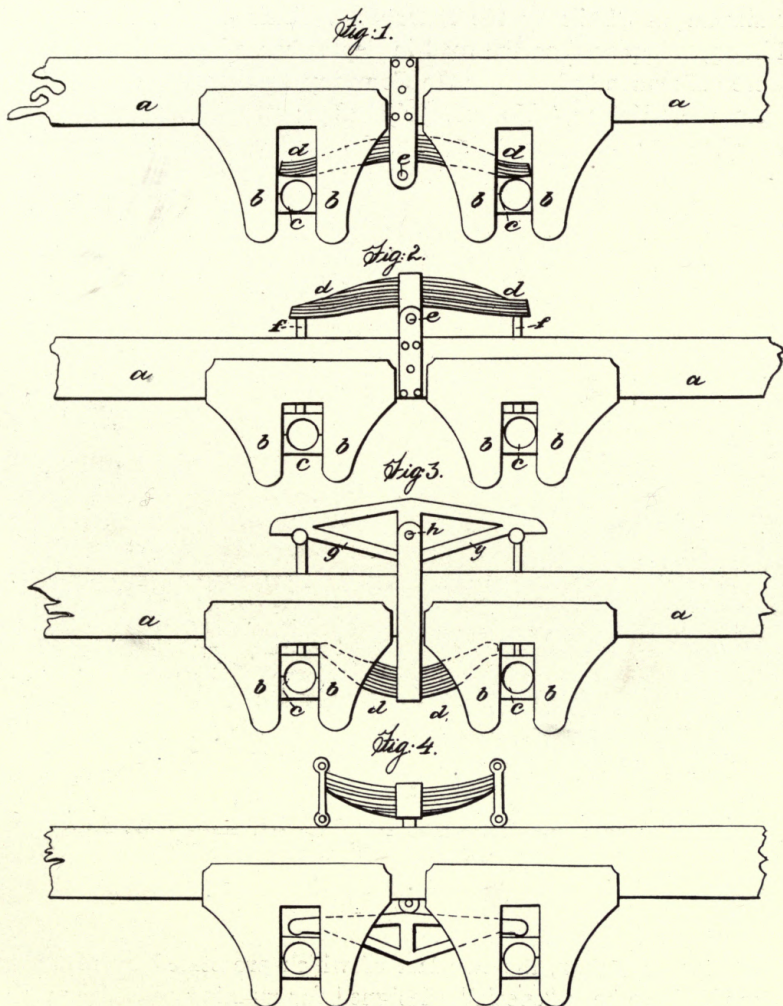

Fig. 11.

In the spring of 1835, the firm of Garrett & Eastwick, subsequently Eastwick & Harrison, of which Joseph Harrison, Jr., was a member, commenced the manufacture of locomotives in Philadelphia, and the first 4-4-0 engine of the Baltimore & Ohio Railroad was built by the latter firm. This engine, the "Atlas," No. 23, was placed on the road in September, 1839, and four others were subsequently built for the Company by the same firm. These were the "Vulcan," No. 26, July, 1840; "Jupiter," No. 27, February, 1840; "Mercury," No. 29, July, 1842, and "Minerva," No.

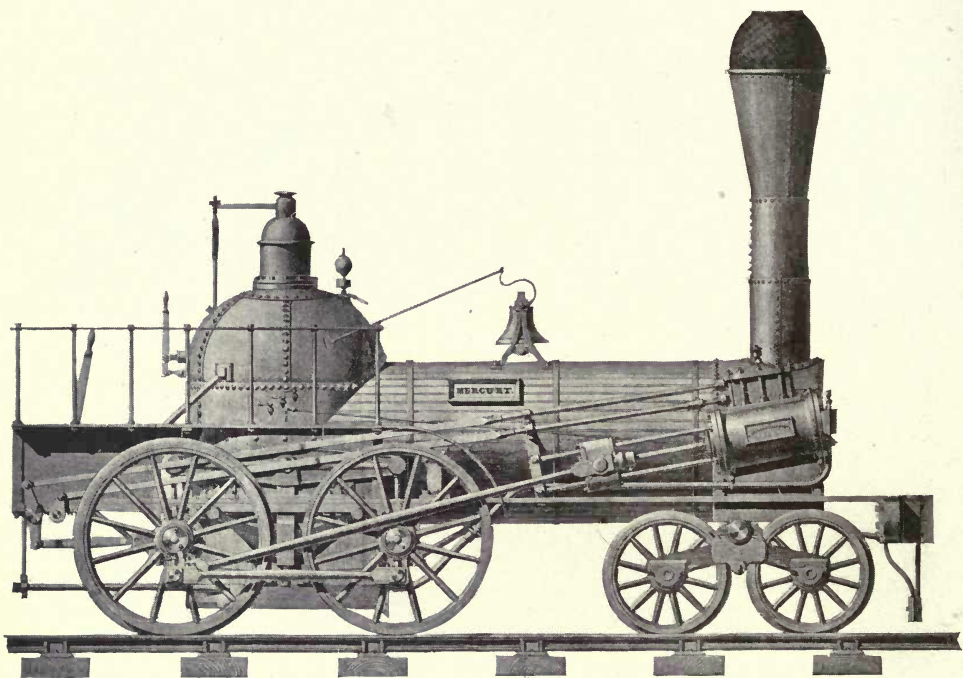

Fig. 12.

30, February, 1842, the two last of which are stated by Mr. Harrison to have been "specially designed for running passenger trains at extra fast speed."

No particulars of Nos. 23, 26 and 27 have been found by the writer, other than the statement in Performance Reports that the cylinders of No. 23 were  $12\frac{1}{2}$  x 20 inches and driving wheels 50 inches diameter. It is probable that these engines were of the same general design as the "Mercury," which is shown in Fig. 12, and which, according to the Report for 1844, ran during that year

37,000 miles, which was assumed to be the largest mileage on record up to that time. The "Mercury" and "Minerva" had 14 x 20 inch cylinders and 60 inch driving wheels.

These engines were fitted with a novel and ingenious form of reverse gear which was patented by A. M. Eastwick, July 21, 1835, and will be presently described, and, in the "Mercury," Eastwick & Harrison first introduced the form of truck which is shown, and which was afterwards adopted by other builders. The side

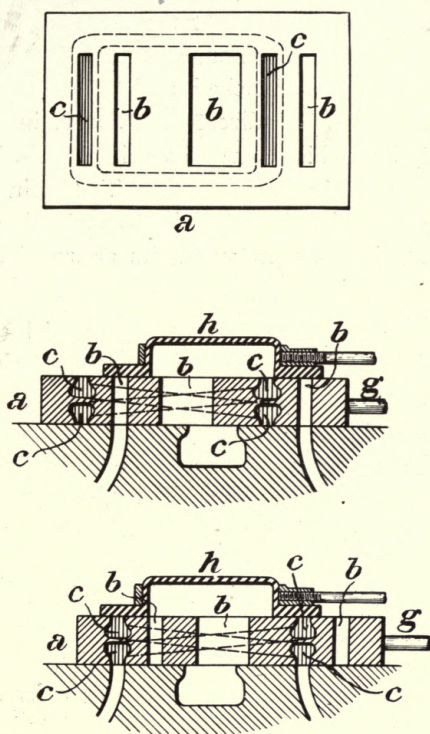

Fig. 13.

frames of this truck were simply long springs, with axle boxes at their ends, and journal boxes on the tops of the spring bands, which were fitted to vibrate on the ends of a wrought iron bolster, on the centre of which the front end of the engine was supported.

In the Eastwick reverse gear, which is shown in Fig. 13, a movable block, *a*, termed a "reversing shifting valve seat," was interposed between the ordinary slide valve, *h*, which was worked

by a single fixed eccentric, and the valve face of the cylinder, and was moved longitudinally on the valve face, for forward or back motion as described, by a stem, *g*, extending through a stuffing box to a reverse lever on the foot plate. Three through ports, *b, b, b*, were formed in the shifting valve seat, and when the seat was set for forward motion, as in the middle diagram, these ports communicated directly with, and constituted extensions of, the cylinder ports. Two other ports, *c, c*, extended partly into the seat from its top, and thence laterally in opposite directions, past the through ports, to the bottom of the seat. When the shifting valve seat was set for back motion, as in the lowest diagram, the end through ports *b, b*, were blocked, and the valve admitted steam to the cylinder through the indirect ports, *c, c*, in opposite direction to the admission which was given in forward motion, thus effecting the reversal of the engine. Notwithstanding the ingenuity of this construction, which is sufficient to make it of interest, its obvious operative objections prevented its approval or adoption by other builders.

Three 4-4-0 engines were built for the road by William Norris: the "Pegasus," No. 24, November, 1839; "Vesta," No. 25, November, 1839, and "Stag," No. 31, May, 1843. The "Stag" appears in Performance Reports as having 12 x 20-inch cylinders, and 60-inch driving wheels, and except as to the reverse gear and outside spring truck, these engines were of the same general design as those of Eastwick & Harrison. They were doubtless similar in all essential particulars to that shown in Fig. 14, which is reproduced from an advertising lithograph, entitled "William Norris & Co. Improved Eight Wheel Locomotive, with Patent Flexible Truck. Manufactured at their works, Bush Hill, Philadelphia, 1843." It is probable that the patent referred to was that of Richard Imlay, of Philadelphia, No. 389, dated September 21, 1837, which covered the use of cylindrical centre bearings, or, as termed in the claim, "vibrating cylinder plates as set forth in the specification, whereby to support all kinds of eight wheeled railroad carriage bodies upon springs." This, however, is not clear from the lithograph.

Ross Winans built three engines of the 4-4-0 type: the "Atalanta," No. 32, October, 1843; "Reindeer," No. 39, December, 1845; and "Juno," No. 52, January, 1848. These engines had 14 x 20-inch cylinders and 60-inch driving wheels, and were also of the same general design as the Eastwick & Harrison engines.

The following five engines of the 4-4-0 type were built for the Baltimore & Ohio Railroad by the New Castle Manufacturing Co., of New Castle, Del.: "Arrow," No. 28, February, 1840; "New Castle," No. 47, December, 1846; "Delaware," No. 48, January, 1847; No. 122, December, 1852, and No. 164, July, 1853. The "Arrow" was the first of the few inside connected engines of the road, and, except the statement in the Twenty-fourth Annual Report, 1850, that "Engine 'Arrow' had new crank shaft, new truck frame, etc.," no particulars of this engine have been found of record.

The other four New Castle engines of this type were of the design which is shown in Fig. 15, and which was standard with these builders during their comparatively short term of operation. It will be observed that the old hemispherical dome over the fire-box was used, as was also the drop-hook valve motion with independent cut-off valves, as in the practice of Norris and others. The New Castle Co. also built the form of truck which was originated by Eastwick & Harrison in the "Mercury" and has been previously referred to. The cylinder dimensions of engines Nos. 47 and 48 are given in the reports as 14 x 20 inches; No. 122, 17 x 20 inches, and No. 164, 15 x 20 inches, and the driving wheels as 60 inches in each case.

Fig. 16 shows one of eight inside connected 4-4-0 engines, known as the "Dutch Wagons," which were designed at the Company's Mount Clare shops in Baltimore shortly after the appointment of Samuel J. Hayes as Master of Machinery. These engines had 15 x 20-inch cylinders, and 60-inch driving wheels, and weighed 56,000 pounds. Four of them were built at Mount Clare: No. 89, January, 1852; No. 95, March, 1852; No. 99, June, 1852, and No. 107, September, 1852. Two more were built by Richard Norris & Son, Philadelphia: No. 200, December, 1853, and No. 201, January, 1854, and two by Murray & Hazlehurst, Baltimore; No. 207, July, 1854, and No. 208, November, 1854.

Five engines of the same general design, Nos. 149, 150, 151, 152 and 153, which were built by the Lawrence Manufacturing Co., Lawrence, Mass., were placed on the road in July, 1854. No representation or description of these engines is extant, but they had the same cylinder and driving wheel dimensions as the "Dutch Wagons," and the writer, who once had the job of working out a wide spread truck for one of them, believes that they were somewhat larger engines.

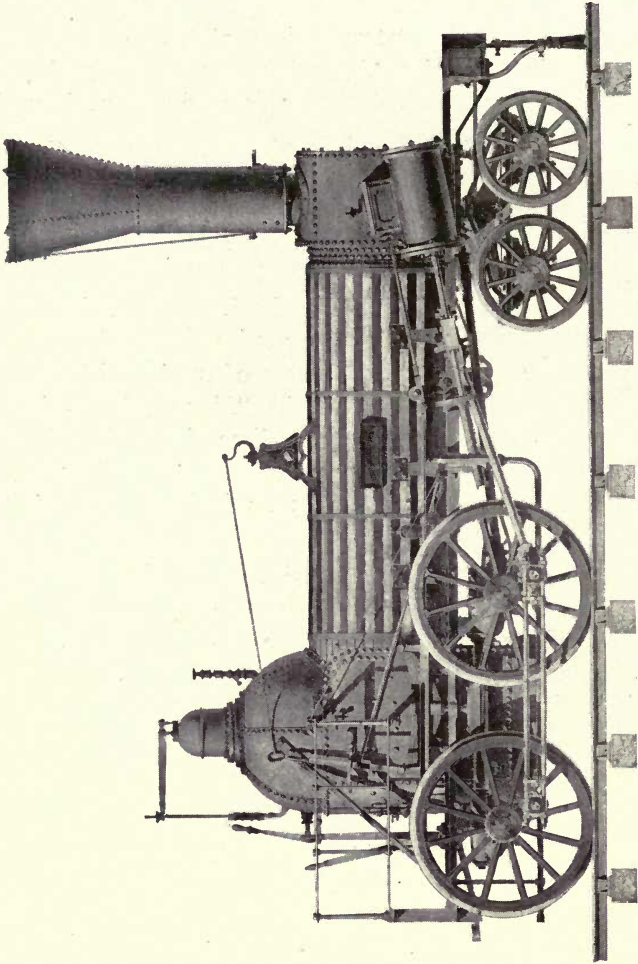

Fig. 14.



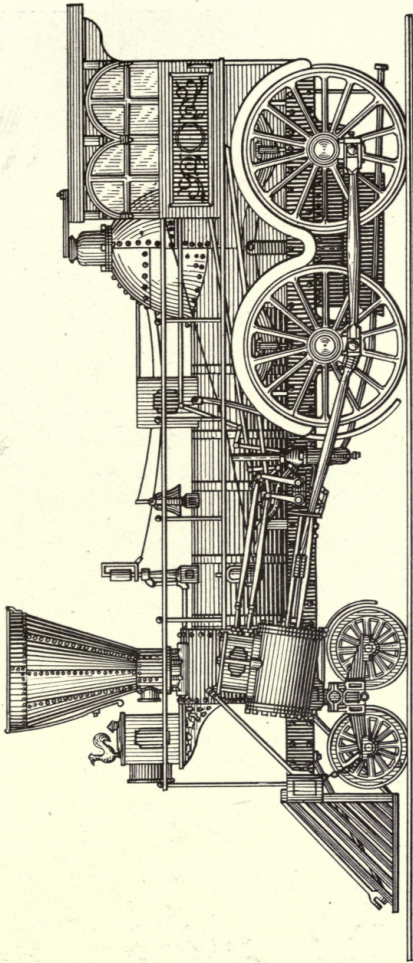

Fig. 15.

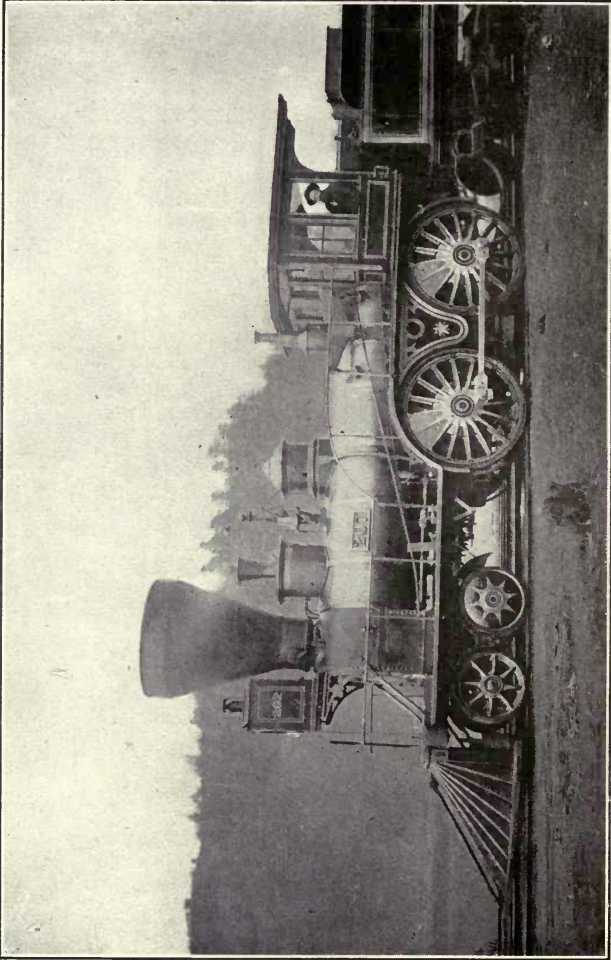

Fig. 16. A "Dutch Wagon", inside connected

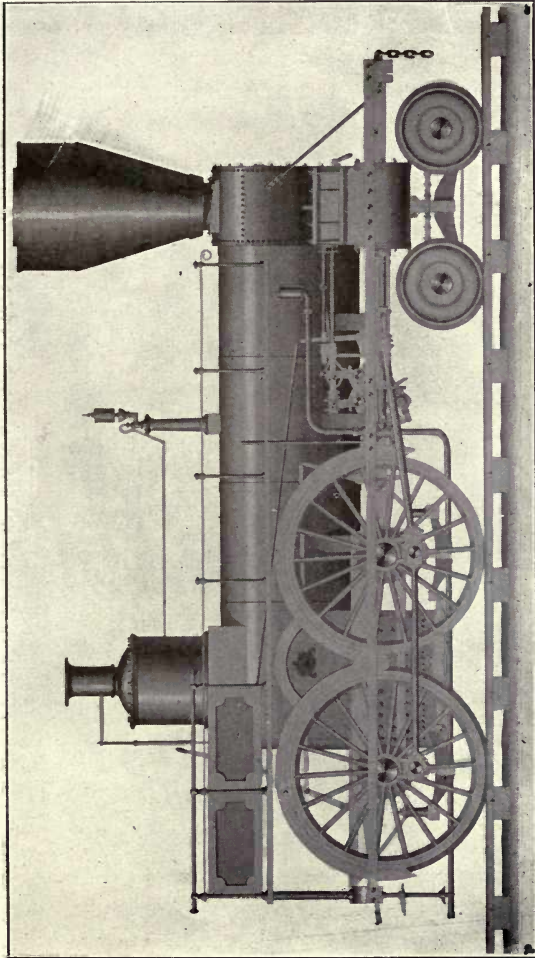

Fig. 17.

Nos. 126 and 127 were built by Richard Norris & Son, January, 1853. They were of the then standard Norris pattern, with independent cut-off valves, 14 x 24-inch cylinders, and 60-inch driving wheels. Fig. 17, which is reduced from a Norris lithograph, illustrates some of the peculiar features of the Norris engines, among which may be noted the slab frames at the sides of the firebox, special arrangement of cut-off valve gear, and underhung springs with equalizers bearing on the mud ring. To what extent these were used in engines Nos. 126 and 127 is not known.

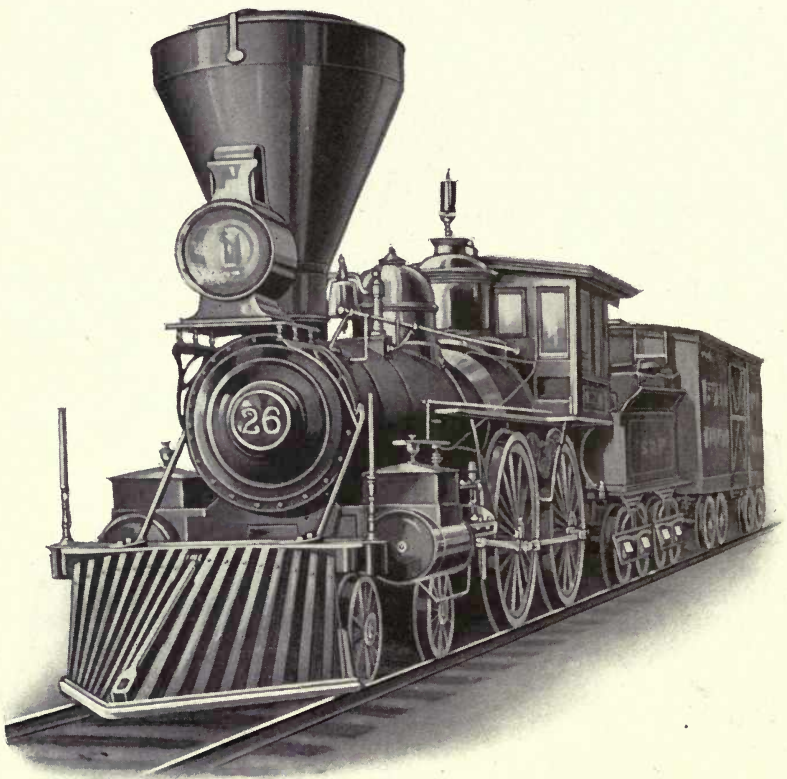

Fig. 17a.

The first 4-4-0 engines of what may properly be termed the modern type, were the new Nos. 25 and 26, which were built by Wm. Mason & Co., Taunton, Mass., and were placed on the road

in November, 1856. They were the first that had link motion valve gear, and round smoke boxes set on cylinder saddles. Their boilers were wagon top, about 46 inches in diameter next to smoke box, cylinders 15 x 22, and 60-inch driving wheels. One of them, No. 25, was shown in the Company's exhibit at the Chicago and St. Louis Expositions, but was fitted with a stack and sand-box of different pattern from those with which it was originally equipped.

Fig. 17a is reproduced from an old photograph, which is the only illustration of these engines which a careful investigation has developed, and shows them in the condition in which they were when built and placed on the road. A similar engine, the "Boreas," which was built by the Mason Works for the Toledo & Illinois Railroad in November, 1856, is reported to have been in service for the exceptionally long period of thirty-four years.

New No. 27, built by the Taunton Locomotive Works, was placed on the road in January, 1859, but is thought to have been built a year or so earlier. This engine was of about the same general design and dimensions as Nos. 25 and 26, and had the same sized cylinders and driving wheels, but her cylinders were inclined and bolted to a flat-sided smoke-box, and the valve motion was of the V-hook type, with independent cut-off valves, operated through "sword arm" or Cuyahoga gear.

The two last of the smaller class of 4-4-0 engines, Nos. 220 and 221, were built by A. & W. Denmead & Sons, of Baltimore, and were placed on the road in February, 1857. These engines had 15 x 20-inch cylinders and 60-inch driving wheels. Fig. 18, which is reproduced from a lithograph issued by the Denmeads, shows one of the few passenger engines that were built by that firm, and the two engines last referred to did not differ materially from this design.

Henry Tyson, an engineer of marked ability and progressive views, who held the position of Master of Machinery of the Baltimore & Ohio Railroad from June, 1856, until some time in 1859, is entitled to the credit of having taken the first steps towards modernizing the motive power of the road. Wm. Mason & Co. began building locomotives at Taunton, Mass., in 1853, and the improvements in structural design and details embodied in their locomotives impressed Mr. Tyson, as they did locomotive builders in the United States generally, with the merits of the Mason engine. The first engines ordered during Mr. Tyson's administration were from the Mason Works, and were the new Nos. 25 and

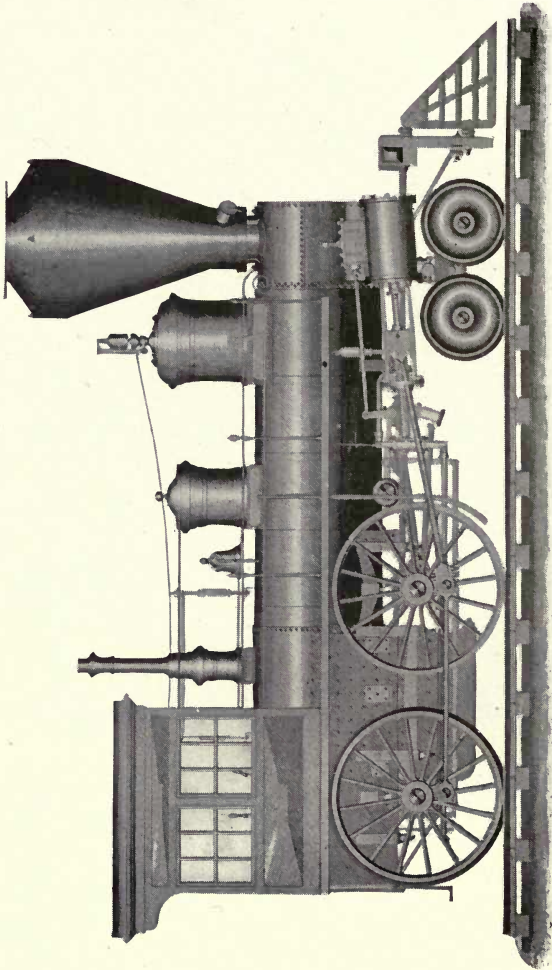

Fig. 18.

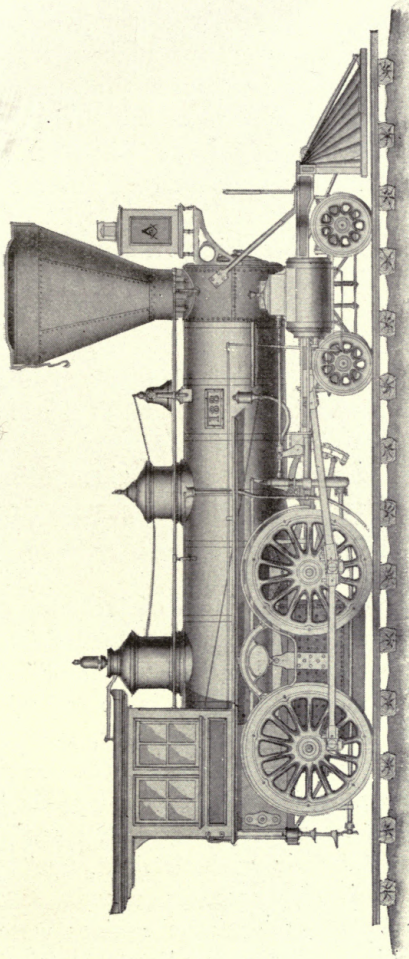

Fig. 19.

26 above noted. This order was followed by another to the same builders for engines Nos. 231, 232, 233, 234, 235 and 236, which were placed on the road in August, 1857. An exact duplicate of these latter engines, No. 188, was built by Mr. Tyson at Mount Clare shops, and was placed on the road in November, 1858.

The typical Mason engine of 1857, the general design of which was adopted by nearly all the locomotive builders of this country, is shown in Fig. 19, which is a reduced reproduction of a drawing of engine No. 188, made accurately to scale by the writer in 1866. The characteristic features of this design comprised the straight, or, properly speaking, telescope boiler, instead of the old dome or wagon type pattern; horizontal cylinders secured to the frame and to a round smoke-box through a cylinder saddle; wide spread truck; elimination of outside frame rails and other excrescences; ogee moulding dome and sand box tops; and a neater and more symmetrical arrangement of link motion and reverse gear. Engines Nos. 231 to 236 and No. 188 had 16 x 22-inch cylinders and 60-inch driving wheels, but no record of their total weight or weight on drivers has been found at the Mason Machine Co.'s works or in the Motive Power Department of the Baltimore & Ohio Railroad. The weight of the engine "Missouri," which was built by Wm. Mason & Co., in the same year, and was of similar construction, except as to having 15 x 22-inch cylinders, is given as 24 tons of 2,240 pounds.

Those whose personal recollection of locomotive practice extends over the fifty-four years that have elapsed since the introduction of what may properly be termed the "typical" Mason engine, are now very few in number, and it is scarcely known to the present generation. Railroad men, however, who were familiar with these engines, will doubtless, like the writer, be in accord with a veteran railroad man, who says: "I well remember these engines—the neatest, best proportioned, trimmest engines ever built by anybody, and they did their work all right, too." To the same effect, a locomotive engineer whose experience was of later date, but within the period when the Mason engines were still in service, makes the following well-expressed statements regarding them and William Mason, their builder:

"How symmetrical the whole machine was, from pilot to draw-bar. \* \* \* As my knowledge of the locomotive grew, year by year, my admiration for the man who paid such close attention to details and who made the locomotive a thing of beauty, grew with it. I have always been sorry that he could not live to see



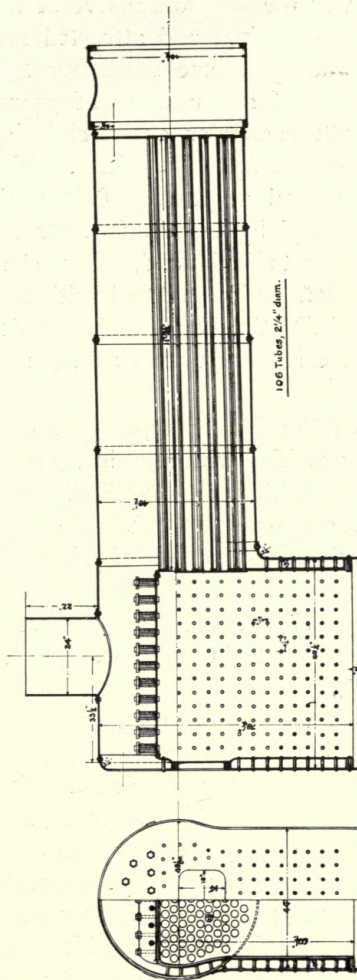

Fig. 20.

so many of his advanced ideas in common use to-day. How many good points the different master mechanics and builders can discover in the Walschaert gear to-day, and how many arguments they could advance against it when Mason tried to get them to give it a trial."

Engine No. 188 was the first locomotive of the road that was painted black with gold striping, and attracted much attention by reason of her novel and handsome appearance. Indian red had been previously, and was for a number of years thereafter, the standard color for both passenger and freight engines, and the substitution of black was a decided novelty, which, although not continued, met with general approval. This engine was, with a number of others, captured by the Confederate forces during the Civil War, and was taken to Richmond, where she was considered to be the best of the lot, and was fitted with a walnut cab and called the "Lady Davis." She was doubtless destroyed, as she does not appear to have been returned, as were a number of the other engines.

Another engine of the Mason type, except as to spring arrangement, and being provided with a 40-inch combustion chamber, new No. 42, was built at Mount Clare during the administration of Thatcher Perkins, some years later. Neither the spring arrangement nor the combustion chamber of this engine proved to be satisfactory.

The boilers of these engines were of 5/16 iron, and, as shown in Fig. 20, were of the "straight" or telescope form, and of the small diameter of  $46\frac{5}{8}$  inches at first ring, with a 24-inch dome over the firebox, which was stayed with crown bars. They had 106 tubes,  $2\frac{1}{4}$  inches in diameter and 11 feet  $2\frac{1}{2}$  inches long. Their firebox heating surface was 86.5 square feet, tube heating surface 694.5 square feet, total heating surface 781 square feet and grate area 15 square feet. They were designed to burn, and successfully burned, bituminous coal, and for a short time were run with coke, and the steam pressure carried was a little above 100 pounds. Except as to the 4-6-0 engines, which were run over the heavy grades, they were the largest and most powerful passenger engines of the road, and rendered efficient service under the conditions of their operation.

One of the most important improvements that have been made in locomotive construction, and one which originated in, and is characteristic of American practice, consists in the so-called "bed-plate" or "saddle," through which the frames, cylinders, and front

end of the boiler are firmly connected together, and the loosening of the cylinders and breakage of the front portions of the frames, which were previously a serious and widespread source of trouble and expense, have been practically done away with. Before its introduction, the cylinders had been bolted to the smoke-box and to the frames in various different ways, all of which were weak and imperfect, and the light and comparatively weak smoke-box, which, even when strengthened by inside bracing, was altogether insufficient for such duty, constituted a distance piece or intermediate abutment for the cylinders. The imperfection of such a construc-

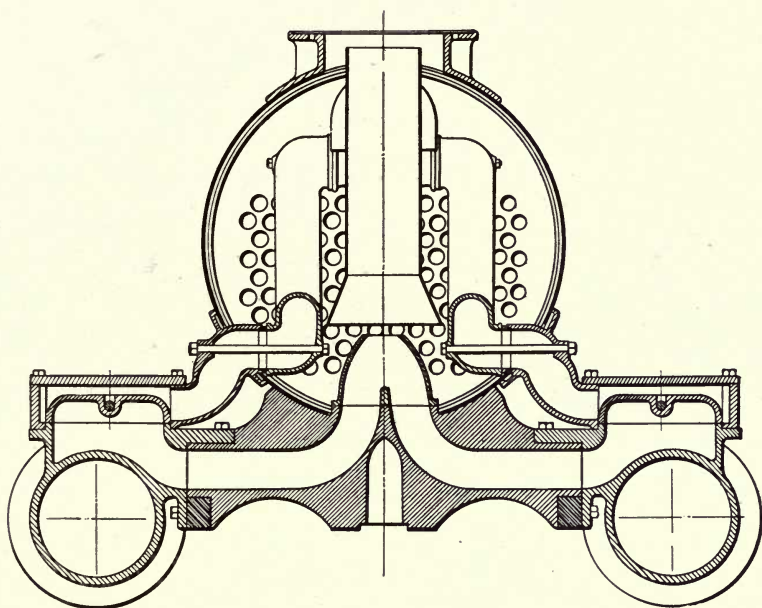

Fig. 20a.

tion is as obvious as the practical mechanical merits of the bed-plate design which displaced it, and the general appreciation and imitation of the Mason engines were largely due to the fact that they were provided with this improvement. It has always been the understanding of the writer that it was first designed and made at the works of Wm. Mason & Co., and so far as has been developed by investigation, this understanding appears to be a correct one.

The original arrangement of bed-plate, cylinders and steam and exhaust pipes, as applied in the Mason engines of 1856 and 1857, before referred to, and in later ones, is shown in Fig. 20a,

from which it will be seen that the bed-plate was an integral casting which was interposed between, and acted as a spacer and transverse brace for, the frames, and that the cylinders were cast separately and bolted to the bed-plate and frames, all the abutting surfaces being finished. The cylindrical smoke-box was seated on and bolted to the correspondingly curved top of the bed-plate. The exhaust passages were cored in the bed-plate, and outside steam pipes were cast on the valve chests and bolted to the branch steam pipes in the smoke-box. The valve chest pipes, or necks, had flanges fitting against the outside of the smoke-box and ball joint rings at their junction with the inside steam pipes. The wide firebox had not been developed at the date of the introduction of the bed-plate, and it was then the practice to set the boiler as low as possible—generally as low as would allow the links, when raised into backing position, to clear the lagging—a low centre of gravity of the locomotive being then considered as desirable, if not absolutely essential. The contrast between the low bed-plate shown in Fig. 20a and the high saddles of present practice will be apparent.

The next step of improvement in this line consisted in casting the bed-plate in two pieces, each integral with one of the cylinders, thus reducing the number of castings from three to two and making what is known as a "half saddle cylinder," and in coring the steam passages in the half saddle sections, thereby dispensing with the outside steam pipes and their joints with the smoke-box. This design is believed to have originated with the Baldwin Locomotive Works, who have a preliminary sketch indicating it, dated in 1857. The half saddle cylinders so formed were somewhat complicated castings, and some railroads have continued to use the bed-plate and separate cylinders. It is also noticeable that a return has been made to the outside steam pipes, which, with a new system of half saddle cylinder construction and connections, have recently been applied in a number of locomotives and met with approval.

It will be seen from the foregoing review of the 4-4-0 engines of the Baltimore & Ohio Railroad, that less than fifty of this type were in service in 1860, and that none of them had driving wheels exceeding 60 inches in diameter. It may also be here noted that all the driving wheel tires were of chilled cast iron.

## CHAPTER IV.

## THE EIGHT-WHEEL CONNECTED FREIGHT ENGINES—TYPE O-8-O.

The Eighteenth Annual Report of the Baltimore & Ohio Railroad (2d Monday of October, 1844) contains the following statement (pp. 11, 12):

“The report of Mr. Knight was submitted and published in March, 1842; and as early as that period, Ross Winans, an ingenious mechanic of Baltimore, had not only contrived a far more important improvement in the locomotive, but had actually constructed an engine weighing twenty tons, running on eight wheels, all of which were drivers, and with the weight equally distributed over the wheels, so as that the bearing upon any one is not greater than upon that of the ordinary machine of ten tons weight, capable of hauling over a level and straight road, *eleven hundred tons*; and over grades of eighty-two and a half feet to the mile, with curvatures of one thousand feet radius, about *one hundred and seventy tons*, at a speed of eight miles per hour.”

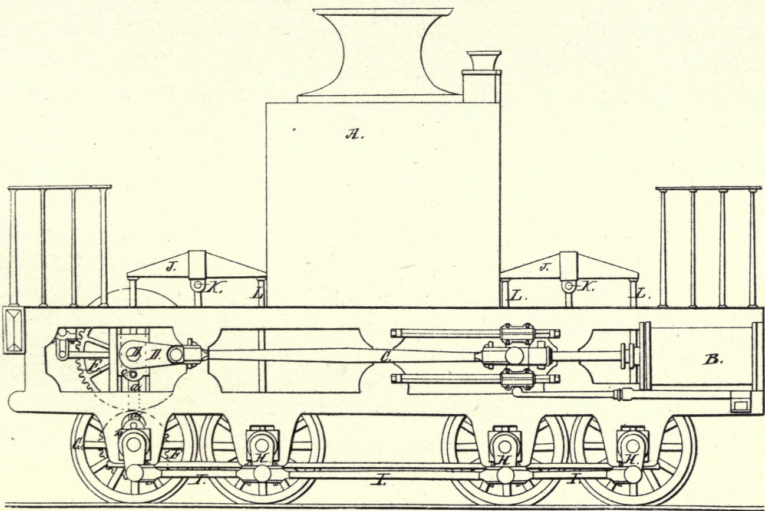

Fig. 21.

The engine referred to was undoubtedly one of three that were built by M. W. Baldwin, under an arrangement with Mr. Winans,

in 1842, for the Western Railroad of Massachusetts, the design of which was in substantial accordance with his Patent No. 3,201, of June 28, 1843, the drawing of which is shown in Fig. 21.

Ross Winans was not the original inventor of a locomotive having eight driving wheels, as a crude form of such a locomotive had been used on the Wylam Colliery Railway, in England, as early as 1815, although the driving wheels of the Wylam engines were not coupled by connecting or side rods, but were driven by spur gearing. He was, however, the first to design and construct an engine having eight driving wheels, coupled by side rods and secured on axles which always remained parallel and had end play in their boxes, or having "blind" or flat tires on the wheels of the intermediate axles. The novel features of Mr. Winans are recited in the following extract from the first claim of his Patent No. 3,201, above mentioned:

"I claim as my invention the construction and use of a locomotive engine, having either six or eight driving wheels, the axles of which are placed parallel to each other, and which are permanently to preserve this parallelism during the whole action of the engine, whether running upon straight or curved roads; the said axles having sufficient end play to allow the wheels, when the whole of them are provided with flanges, to adapt themselves to the curvatures of the road; or instead of this end play of the axles, the constructing of two of the pairs of wheels where eight are used, without flanges, the motive power from the steam engine to be transmitted to the first pair of driving wheels, through the intermedium of a fifth axle, furnished with spur wheels, which gear into small spur wheels or pinions on the axle of the first pair of driving wheels, and the power from these wheels being transmitted to the whole system of driving wheels, by means of cranks on the axles of said wheels and suitable connecting rods, as set forth."

(1) In the "Report on the Use of Anthracite Coal in Locomotive Engines on the Reading Railroad," made by Geo. W. Whistler, Jr., April 20, 1849, it is stated (p. 23) that, "In October of that year [1844] Ross Winans produced the first successful coal burning engine with a horizontal boiler," and the report further states that twelve of these engines were placed on the Baltimore & Ohio Railroad between October, 1844, and December, 1846, and that a substantially similar engine was built by the Company in May, 1847.

These engines, which were the first of the o-8-o type on the Baltimore & Ohio Railroad, were known as the "Mud Diggers," and are shown in Fig. 22, which is reproduced from a photograph of engine No. 37, which was made at Mount Clare shops in 1863, and was in possession of the writer until loaned, with others, for exhibition at Chicago. These photographs were never returned and the imperfection of the illustration is due to the fact that it was made from a wood engraving reproduced from the photograph referred to, the loss of which rendered the engraving the only representation that could be obtained. The "mud diggers" weighed 23.5 tons and had 17 x 24-inch cylinders. The main connecting rods were coupled to cranks on a shaft extending across the frames, in

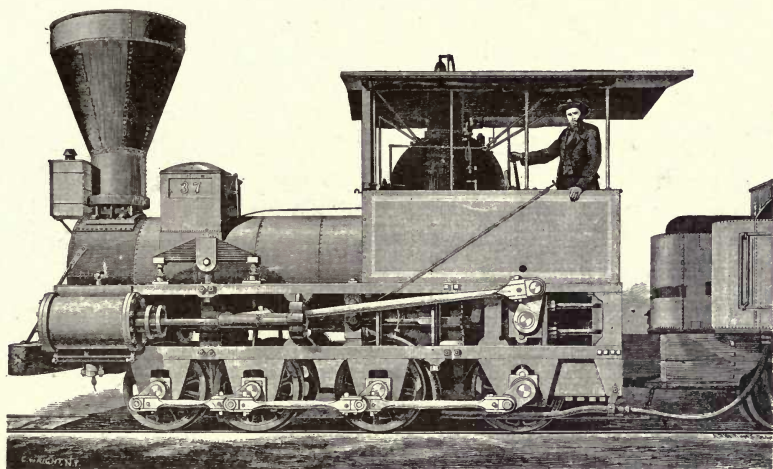

Fig. 22. "MUD DIGGER"

the rear of the firebox, and geared by spur wheels to the back driving axle. The driving wheels were 33 inches in diameter, and the driving axles carried end cranks which were coupled by side rods. As the main and side rods moved in opposite directions, by reason of the interposed gearing, these engines presented a novel and peculiar appearance when in motion.

The twelve Winans engines referred to in Mr. Whistler's report, which were "mud diggers," were the "Hercules," No. 33, October, 1844; "Gladiator," No. 34, November, 1844; "Buffalo," No. 35, November, 1844; "Baltimore," No. 36, December, 1844; "Cumberland," No. 37, July, 1845; "Elephant," No. 38, July, 1845;

"Opequan," No. 40, July, 1846; "Elk," No. 41, August, 1846; "Catoclin," No. 42, October, 1846; "Youghiogeny," No. 43, November, 1846; "Tuscarora," No. 45, December, 1846, and "Allegheny," No. 46, December, 1846. The mud digger built by the Company was the "Mount Clare," No. 49, May, 1847.

Some of these engines were in yard service as late as 1865, and probably for some years afterward. A number of their cylinders and main connections were used as parts of stationary engines in the shops of the road after their road service was terminated. These engines were the first of the 0-8-0 type that were built in the United States, except the three referred to as built for the Western Railroad of Massachusetts.

(2) The 0-8-0 engines next in order of date to the mud diggers were direct connected, with inclined cylinders and independent cut-off valves, the general design being that which was originated by M. W. Baldwin, in an order of seventeen engines built by him in 1846 for the Philadelphia & Reading Railroad, and which continued to be the standard pattern of the Baldwin works for heavy freight and pusher service, up to about 1865. The first of these engines, the "Dragon," No. 51, was built by M. W. Baldwin and was placed on the road in January, 1848. The firebox of this engine was between the two rear axles, as in the 4-4-0 type, and the engine had cylinders  $14\frac{1}{2}$  x 18 inches, driving wheels 43 inches, 108 tubes in boiler, and weighed 41,000 pounds. The tender was six wheeled, with a water capacity of 1,200 gallons.

The bearings of the front and second axles of the "Dragon," all four wheels of which axles were flanged, were fitted in what was known as the "Baldwin flexible beam truck." This construction, which was an extremely ingenious one, and was used in a large number of locomotives on other roads for many years, was the subject of Patent No. 2,759, issued to M. W. Baldwin, August 25, 1842, and is shown in Figs. 23 and 24, and it is believed to be of sufficient interest to warrant the following description, which is taken from the first Illustrated Catalogue of the Baldwin Locomotive Works, published in 1874 (pp. 20-22). The description refers to a six-wheel connected engine, but is equally applicable to those of the 0-8-0 type.

"The engine was on six wheels, all connected as drivers. The rear wheels were placed rigidly in the frames, usually behind the firebox, with inside bearings. The cylinders were inclined, and with outside connections. The four remaining wheels had inside



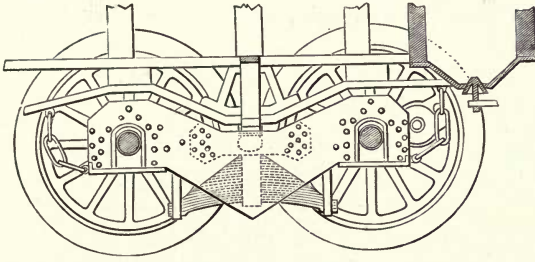

Fig. 23.

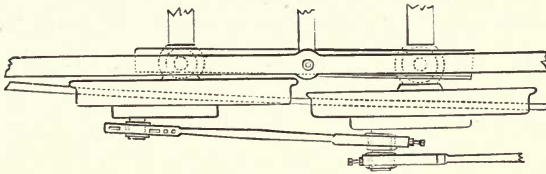

Fig. 24.

journals running in boxes held by two wide and deep wrought-iron beams, one on each side. These beams were unconnected and entirely independent of each other. The pedestals formed in them were bored out cylindrically, and into them cylindrical boxes, as patented by him in 1835, were fitted. The engine-frame on each side was directly over the beam and a spherical pin, running down from the frame, bore in a socket in the beam midway between the two axles. It will thus be seen that each side-beam independently could turn horizontally or vertically under the spherical pin, and the cylindrical boxes could also turn in the pedestals. Hence, in passing a curve, the middle pair of drivers could move laterally in one direction—say to the right—while the front pair could move in the opposite direction, or to the left; the two axles all the while remaining parallel to each other and to the rear driving-axle. The operation of these beams was, therefore, like that of the parallel-ruler. On a straight line the two beams and the two axles formed a rectangle; on curves, a parallelogram, the angles varying with the degree of curvature. The coupling rods were made with cylindrical brasses, thus forming ball-and-socket joints, to enable them to accommodate themselves to the lateral movements of the wheels. Colburn, in his *'Locomotive Engineering,'* remarks of this arrangement of rods as follows:

“Geometrically, no doubt, this combination of wheels could only work properly around curves by a lengthening and shortening of the rods which served to couple the principal pair of driving-wheels with the hind truck-wheels. But if the coupling rods from the principal pair of driving-wheels be five feet long, and if the beams of the truck-frame be four feet long (the radius of curve described by the axle-boxes around the spherical side bearings being two feet), then the total corresponding lengthening of the coupling rods, in order to allow the hind truck-wheels to move one inch to one side, and the front wheels of the truck one inch to the other side of their normal position on a straight line, would be  $\sqrt{60^2+1^2}-60+24-\sqrt{24^2-1^2}=0.0275$  inch, or less than one thirty-second of an inch. And if only one pair of driving-wheels were thus coupled with a four-wheeled truck, the total wheel-base being nine feet, the motion permitted by this slight elongation of the coupling rods (an elongation provided for by a trifling slackness in the brasses) would enable three pairs of wheels to stand without binding in a curve of only one hundred feet radius.”

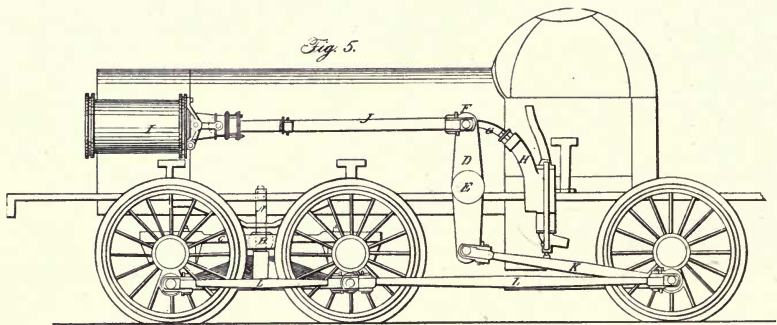

Fig. 25.

Fig. 25 is a reproduction of Fig. 5 of Patent No. 2,759, and is noteworthy in its showing of a vibrating beam connection between the piston rod and main connecting rod, a construction which was revived many years afterwards by Charles Brown of Winterthur, Switzerland, and also as to the curved pump barrel and piston rod.

Three more engines of this class, but of larger size and modified form, were built for the road by M. W. Baldwin, as the result of an advertisement for proposals which was published by the Baltimore & Ohio Railroad Company, in the *American Railroad*

*Journal* of October 23, 1847. This advertisement is of interest as showing what were then considered to be the requirements for a heavy freight locomotive, and is as follows:

“TO LOCOMOTIVE ENGINE BUILDERS:

Proposals under seal will be received by the undersigned up to SATURDAY, the 6th of November, inclusive, for furnishing the Baltimore & Ohio Railroad Co. with 4 LOCOMOTIVE ENGINES, in conformity with the following specification:

1. The weight not to exceed 20 tons of 2,240 lbs., and to come as near to that limit as possible.
2. The weight to be uniformly distributed upon all the wheels, when the engine is drawing her heaviest load.
3. The number of wheels to be *eight*.
4. The diameter of the wheels to be 43 inches.
5. The four intermediate wheels to be without flanges.
6. The boiler to contain not less than 1,000 square feet of fire surface, of which there shall be not less than one-fifteenth in the firebox.
7. The tubes of No. 11 flue iron, with not less than  $\frac{3}{4}$  of an inch space between them in the tube sheets.
8. The firebox, with the exception of the tubè and crown sheets, to be of  $\frac{2}{3}$ -inch copper.
9. The tube sheets to be  $\frac{3}{8}$ -inch thick.
10. The boiler to be of No. 3 iron, of the best quality.
11. The firebox to be not less than 24 inches deep below the cylindrical part of the boiler.
12. The steam to be taken to the cylinder from a separate dome on the forepart of the boiler.
13. The frame, including the pedestals, to be entirely of wrought iron, and the boiler to be connected therewith, so as to allow of contraction and expansion without strain on either.
14. The cylinders to be 22 inches stroke, and not less than 17 inches diameter.
15. The cut-off to be effected by a double valve, worked by separate eccentrics.
16. The angle of the cylinder to be not greater than  $13\frac{1}{2}$  degrees with the horizontal line.
17. The frame and bearings to be inside the wheels and the direction from the cylinder direct with the back pair of intermediate wheels.

18. The centres of the extreme wheels to be not more than  $11\frac{1}{2}$  feet apart.

19. The wheels to be of cast iron with chilled tire.

20. The means to be provided of varying the power of the exhaust in the blast pipe.

21. The engine to be warranted to do full work with Cumberland or other bituminous coal, in a raw state, as the fuel, and the furnace to be provided with an upper and lower fire-door with that view.

22. The smokestack to be provided with a wire gauze covering.

23. Two safety valves to be placed upon the boiler, each containing not less than five square inches of surface and one to be out of the reach of the engineman.

24. The tender to be upon 8 wheels and constructed upon such plan as shall be furnished by the Company, and to carry not less than 3 cords of wood or its equivalent in coal, and 1,500 gallons of water.

25. The materials and workmanship to be of the best quality, and the engine to be subjected to a trial of 30 days' steady work with freight upon the road before acceptance by the Company.

Payment to be made in cash on the acceptance of the engine. The four engines to be delivered at the Company's Mount Clare depot, in Baltimore—the first on the 1st of February, 1848, and the three others on the 1st of March, April and May, ensuing.

The track is 4 feet  $8\frac{1}{2}$  inches gauge, and the shortest curve of the road is 400 feet radius.

The Company to be secured against all patent claims.

Further information will be communicated upon application to the undersigned, at the Company's office, No. 23 Hanover Street, Baltimore, to which the proposals suitably endorsed will be addressed.

By order of the President and Directors,

BENJ. H. LATROBE,

Chief Engineer and General Superintendent.

Baltimore, September 18, 1847."

A contract for five engines of the construction called for by the above advertisement was awarded to M. W. Baldwin, but by reason of his inability to furnish all of them within the time limit imposed by the Company, three only were built by him, these being the "Hector," No. 58, and "Cossack," No. 60, December, 1848:

and "Tartar," No. 62, January, 1849. The drawing of engine No. 58, which is shown in Fig. 26, was made from the recollection of the writer, in connection with the drawing shown in Fig. 27, and with old sketches and others made from engine No. 57, which, as changed in some particulars and incorrectly labelled "Dragon," was shown at the Chicago and St. Louis Expositions.

No definite and authenticated data as to these engines has been, after careful examination, developed in the records of either the Baldwin Locomotive Works or the Motive Power Department of the road, and questions as to their construction have arisen, which remain undetermined. As shown by correspondence, their weight exceeded that specified, being reported to have been at first about 52,000 pounds, and to have been reduced by changes to about 47,000 pounds. Their cylinders are, however, known to

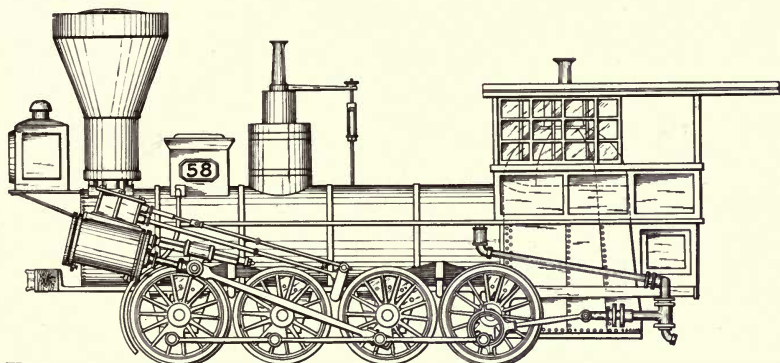

Fig. 26.

have been 17 x 22 inches, and their driving-wheels 43 inches, as specified in the advertisement. As the writer remembers the engines in service in 1857 and thereafter, all the driving boxes were in pedestals in the main frame, the Baldwin flexible beam truck not being used; the second and third pairs of wheels were not flanged, and the axles were closely set to conform to the limitation of wheel-base specified in Section 18 of the advertisement. The firebox was of rectangular section, with a hemispherical or "Bury" dome on its top, and the back wall was rearwardly inclined from top to bottom, so as to provide larger grate area, and had upper and lower firedoors, as specified in Section 21. The pumps were 11-inch stroke, and were worked by eccentrics on the crank pins of the rear wheels.

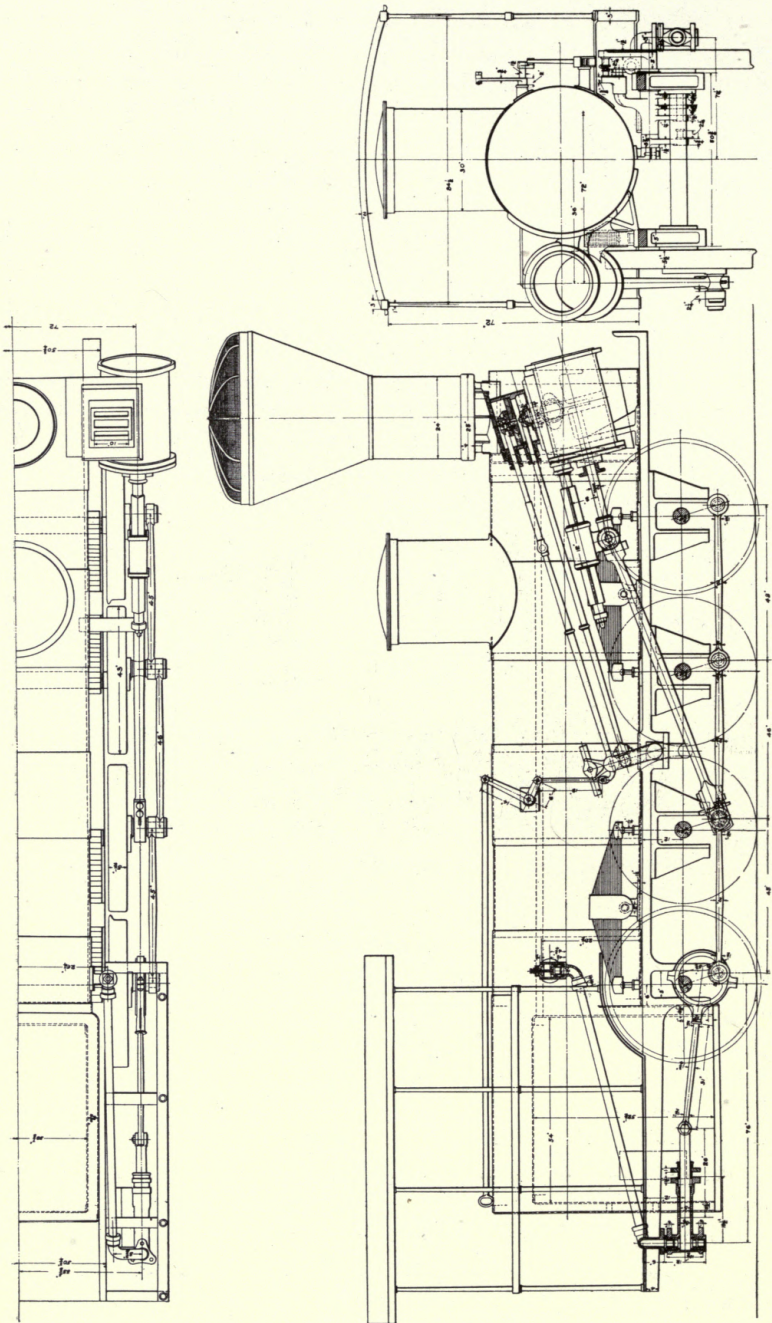

Fig. 27.

Fig. 27 is a reduced reproduction of a tracing, made many years ago, under the writer's supervision, from a drawing which was not entitled or dated, and which was in one of the cases in the drawing room of the Machinery Department of the Baltimore & Ohio Railroad in 1863, and for a number of years thereafter, but which, with other representations of early practice, was destroyed by the order before referred to, of a Superintendent of Motive Power who failed to appreciate their historical value. This drawing is in accordance with the writer's recollection of the engines last mentioned in all essential particulars, and differs from it only in not showing the back of the firebox as inclined, and provided with upper and lower firedoors, and with a "Bury" dome on its top.

The only drawing found at the Baldwin Locomotive Works which was thought to represent these engines, was one in pencil, bearing the marks of age, but not dated, and entitled "Engine for The Baltimore & Ohio R. R. Co., Cylinder 17" diam., 22" stroke." This drawing shows the engine as having the Baldwin "flexible beam truck" and cross-head pumps, and the firebox, while having a "Bury" dome on its top, is not inclined at its rear, and does not have upper and lower fire doors. This drawing, which may have been only a preliminary sketch, is not identified further than by its title as above, and for that reason, as well as for the reason that it is not in accord with the specification for the engines, nor with the writer's clear recollection of their actual construction, he feels confident that he is correct in his statements regarding them.

Claim having been made by Ross Winans, that the use of chilled tires and variable exhaust, which were called for by Sections 19 and 20 of the specifications, would infringe his patents, Mr. Baldwin was released from these requirements by a letter from Benj. H. Latrobe, Chief Engineer, dated April 12, 1848, in which Mr. Latrobe said:

"You will be expected to direct your best efforts to provide the engines with the best substitute for the variable exhaust as a means of increasing and diminishing the draught at pleasure. The use of rolled iron tires will obviate the chilled wheel patent. I would suggest you to try Mr. Horatio Hines' *twisted* iron for the tires."

Confirming this authorization of variation from the specification, Mr. Latrobe, in a letter to Mr. Baldwin, dated May 16, 1848, advised him of the following modification of the contract for the engines, viz.:

"The President has authorized the addition of \$350 to the contract of \$9,000 in consideration of the increased expense you will incur in putting wrought iron tires on the wheels. *The tire is to be  $1\frac{5}{8}$  inches thick.*

"It is preferred to incur this addition to the cost of the engine to going at this time into a contest with Mr. Winans on this point."

There is no record of the manner in which the wrought iron tires were fastened to the wheel centres, and it is quite probable that this may have been in accordance with the patent of Thatcher Perkins and William McMahon, No. 3037, dated April 10, 1843.

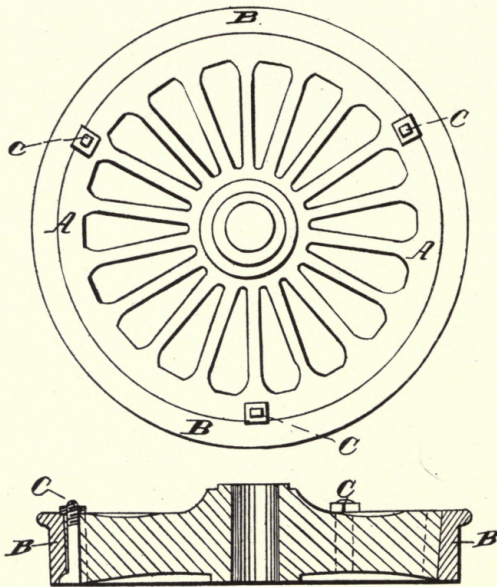

Fig. 28.

which was adopted as, and remained the standard practice of the road, for cast-iron centres and chilled tires, on both passenger and freight engines, until the introduction of steel tires, in the year 1873.

Fig. 28, which is a reproduction of the drawing of the Perkins and McMahon patent, clearly shows the manner in which the tire and wheel centre were connected. The centre was turned to a slight taper and the tire correspondingly bored; the tire was then forced on the centre and secured by transverse hook-headed bolts



(usually seven), which fitted between the centre and tire and were drawn to a bearing by nuts on the flange side. This plan was a simple and effective one, and was found satisfactory in practice for many years.

Engine "Saturn," No. 56, is stated in the Company's reports as having been built by the New Castle Manufacturing Co., in June, 1848, and engine "Memnon," No. 57, by M. W. Baldwin, in October, 1848, but the latter does not appear in the records of the Baldwin Locomotive Works. Engines "Hero," No. 54; "Giant," No. 63, and "Lion," No. 64, are stated in the reports as having been built by the Railroad Company in May, 1848, May, 1849, and March, 1850, respectively. All these engines were of the same general construction as those last described, and were the last of this class that were placed on the road.

Colburn's small treatise, *The Locomotive Engine*, Philadelphia, 1851, contains, on pages 58 to 61, a description of a feed-water heating apparatus which was applied to engine No. 54, and was designed by Thatcher Perkins, then Master of Machinery. This apparatus constitutes the subject matter of Mr. Perkins' Patent No. 6,561, dated June 26, 1849, and will be understood by reference to Fig. 29, which is taken from the patent. While its theory, as indicated in Colburn's description, appears to be a correct one, its practical operation was doubtless not found to be satisfactory, as there is no record of its further application.

"We will add a few particulars of an engine for burning bituminous coal, which was constructed for the Baltimore & Ohio Railroad by Thatcher Perkins, master of machinery on that road. The performance of this engine during the year 1849 was upward of 23,000 miles, and was higher than that of any other first-class engine on that road for the same time.

"The diameter of the cylinder was 17 inches; stroke of piston, 22 inches; four pairs of driving-wheels having chilled tires 43 inches in diameter. The diameter of the boiler was 44 inches, and there were 125 wrought-iron tubes, 12 feet 6 inches long and  $2\frac{1}{8}$  inches diameter at the firebox end and  $2\frac{3}{8}$  inches diameter at the smoke-box ends of same. The grate was  $37\frac{1}{2}$  inches long by  $41\frac{1}{2}$  inches wide and the inside depth from crown sheet to grate was 50 inches. Attached to the boiler of this engine was the patent apparatus for heating the feed water by the surplus exhaust steam of the engine, which was invented by Mr. Perkins. The exhaust steam from both cylinders enters a square box in the

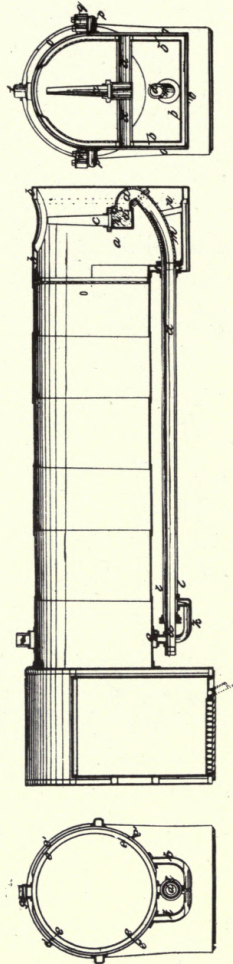

Fig. 29.

centre of the smoke-box. In this box is a movable valve by which the steam can be discharged through the ordinary blast pipes, or turned into a pipe leading to a steam casing surrounding the smoke-box. This pipe also continues along beneath the boiler, and is united to a steam belt surrounding the same at the firebox end, and from which the steam finally escapes through a pipe for that purpose. The feed water can be admitted directly to the boiler, near the firebox end of this pipe, or, which is intended in running, it can be pumped into a casing surrounding this pipe, from whence it passes into a water casing surrounding the smoke-box, and within the steam casing already mentioned. From here it passes into the boiler a little below the water level, at the smoke-box end. In this arrangement the movable valve in the steam-box can be regulated to discharge steam enough through the blast pipes for all ordinary purposes of draught, and also to maintain a flow of steam through the pipe beneath the boiler. The feed water receives a large portion of the heat of this steam, from its contact with it in the casing surrounding the pipe, and, retaining the heat so obtained, it passes into the water casing in the smoke-box, where it is exposed to the heat of the waste steam on the outside, and to the temperature of the smoke-box within. It thus, when finally admitted to the boiler, has become heated quite to the boiling point, as the heat within the smoke-box of a coal engine is very great, even with long tubes. This arrangement operates as a variable exhaust by allowing any portion of the waste steam to be turned off from the blast pipes; it effects a considerable economy in fuel by giving the water to the boiler, already heated very hot; and the water casing surrounding the smoke-box prevents the destruction of the latter by the heat emitted from the tubes.

"In the details of this engine the expansion valve was worked from the backing eccentric, and one lever sufficed for reversing the engine and throwing on the cut-off. This was effected by making the cut-off rocker arm work as a shell on the main valve rocker shaft, the cams for throwing out all the hooks being on the same cam shaft, and that for the forward hook being only a quarter cam, so as to allow that hook to be on its pin in the rocker arm in two positions of the reversing lever; that is to say, going forward with the cut-off on, and forward with it off."

(3) Another class of 0-8-0 engines which was put in service on the road was that known as the "Company's eight-wheel engine," and is shown in Fig. 30, which was prepared from an old hand sketch made by the writer.

These engines, which were new Nos. 33, 34, 38, 40, 43 and 49; "Tiger," No. 67; Nos. 72, 76, 83 and 131, were built at different dates from October, 1850, to November, 1853. Nos. 67, 72 and 83 had cylinders 20 x 22, and the others 19 x 22; the driving wheels of all of them were 43 inches. A report of their performance will be found in Colburn's *Locomotive Engineering*, pages 82 and 83, which gives the following particulars of the engines: Weight, 57,400 pounds; firebox heating surface, 87.5 square feet; tube heating surface, 984 square feet; total heating surface, 1,071.5 square feet; grate area, 18 square feet; number of tubes, 134; diameter of tubes, 2 inches; length, 14 feet.

The cylinders were, as shown, set horizontally, and they were bolted to a flat-sided smoke-box, the bed-plate or saddle not being then known. The valves were worked by drop hook gear, which re-

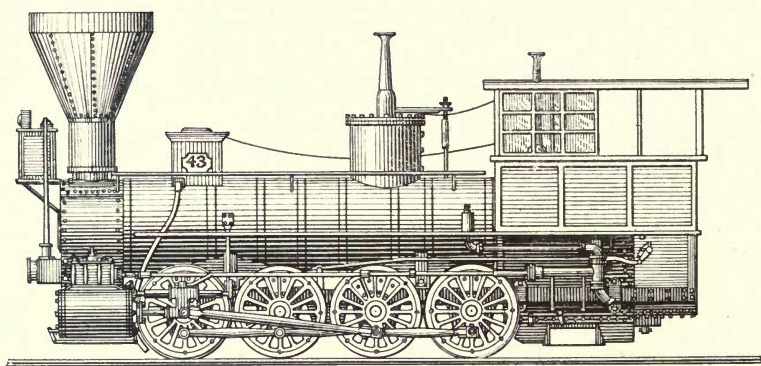

Fig. 30.

quired connections, as shown, for starting bars. The writer believes that the first application of solid ended side rods was made in these engines, and also that this form of side rod originated with Thatcher Perkins.

(4) The design of the 0-8-0 type, which was the last that, prior to 1865, was put in service on the Baltimore & Ohio Railroad, was the class known as the "camel" engines of Ross Winans. This locomotive was designed by and absolutely original with him, and he built 119 for the road between June, 1848, and February, 1857. Zerah Colburn, in a brief description of the camel engine, which he gives in *Recent Practice in the Locomotive Engine*, 1860, said, with his accustomed accuracy and aptness, that it "is, as a whole, the most peculiar engine in use in the United

States. \* \* \* In every detail of construction this engine is alike peculiar, and in the strongest possible contrast with the proportions, arrangement, and workmanship of the standard American engine." M. N. Forney, who served his apprenticeship in Winans' shop, commencing April 28, 1852, in a descriptive article in the *American Engineer and Railroad Journal*, says: "The details of these locomotives had many interesting features, and the whole machine was designed with wonderful skill and ingenuity, and the chief aim of their construction seemed to be to produce locomotives with a maximum capacity at a minimum cost. The safety of the men who had to run them seemed to have received less consideration. The object aimed at was apparently accomplished, as these locomotives certainly did a greater amount of work than any of their contemporaries, and Mr. Winans made a princely fortune by building them."

The distinctive features of novelty of the camel engines were the following: 1. The use of eight driving wheels, set closely between horizontal cylinders and a long overhung firebox, the width of which was equal to, or greater than, the distance over frames. 2. A firebox having a downwardly and rearwardly inclined top, which was exclusively a water casing, there being no steam room in it. 3. A dome and engineer's cab, placed on the top of the boiler, close to the forward end. 4. An upper chute, or pair of chutes, for feeding coal through the top of the firebox. 5. A firebox having no water space on its rear side, which was closed by doors, so as to expose its entire area when desired. 6. The abandonment of crown-sheet stay bars, and the substitution of stay bolts connecting the crown sheet with the outer shell. 7. The use of a half-stroke cam, as a means of effecting cut-off. All these engines were substantially of the same pattern, except as to the firebox, of which there were three classes, the short, the medium and the long.

The first engine of this class, the "Camel," No. 55, was placed on the road in June, 1848, and corresponded substantially with Fig. 31, which is reproduced from Ross Winans' Patent No. 20,117, dated April 27, 1858. The cylinders of this engine were 17 x 22 inches, and it is believed to have been the only camel that had cylinders of smaller diameter than 19 inches. The fireboxes of the short furnace camels, as shown on drawings to scale accompanying patents issued to Mr. Winans, were 6 feet x 3 feet 6 inches, inside dimensions, giving a great area of 21 square feet, and their boilers, as well as those of the medium and long furnace classes, were 46 and

46  $\frac{5}{16}$  inches in diameter, of  $\frac{5}{16}$ -inch iron, single rivetted, and had 103 tubes, 2  $\frac{1}{2}$  inches outside diameter and 14 feet  $\frac{1}{4}$  inches long. Their weight was 22.5 tons (of 2,240 lbs.), all of which was carried on eight driving wheels, 43 inches in diameter, set as closely together as possible, the total wheel-base being only 11 feet 3 inches. In all three classes, a dome 41  $\frac{1}{2}$  inches in diameter was located a short distance behind the smoke-box, and the cab, which was very roomy, was in all cases on the top of the boiler and extended from the front of the dome nearly to the firebox. The frames were each made of two slabs or plates of  $\frac{5}{8}$  iron, 15 inches deep between the pedestals, which were forged on them,

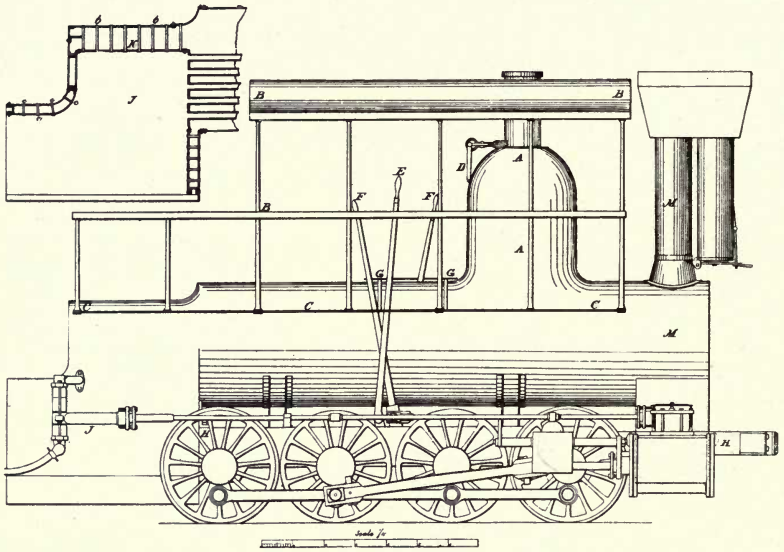

Fig. 31.

and they were spaced 6 inches apart, with the springs between them, and extended only to the front of the firebox.

Only a small number of the short furnace class of camels were built by Ross Winans, and in all other engines built by him the top of the firebox was inclined downwardly from the waist of the boiler to the rear end, both the outside sheets and the crown sheet being flat, without steam space between them, and connected by stay bolts, as the side sheets of fireboxes now are. Two chutes or "fuel-feeding boxes" were placed on the top of the firebox, these having sliding doors at bottom and hinged doors at top, op-

erated by levers. The tender had upper and lower decks, or "platforms," to enable firing to be done through these chutes, or through the fire doors in the ordinary manner. The patent of Ross Winans, No. 10,901, dated May 9, 1854, shows the short firebox and the medium length firebox, the latter both with and without the chutes, and the claim of the reissue of this patent (No. 470, dated June 16, 1857) is as follows:

"The downward and rearward inclination of the top or roof, in combination with the flat grate surface and the usual feeding hole or door, and with or without the fuel-feeding boxes through the roof, as herein described."

The writer has never, throughout an extended experience in connection with the investigation and study of published records relating to locomotive construction in this and other countries, developed any description or illustration which would indicate that this design of firebox was not original with Ross Winans, and he believes that the claim above quoted was a good and valid one, and would have been sustained if a suit had been brought under it. With regard to the mechanical merit of the design, the view expressed by M. N. Forney, in his *American Engineer* article before referred to, is worthy of consideration. Mr. Forney there makes the following statement:

"With the experience of a half century to guide us, much can now be said in favor of this form of firebox. The boiler shop of the Pennsylvania Railroad, at Altoona, was formerly under the charge of a very intelligent foreman, Mr. Nixon. A few years ago the writer made a special effort to ascertain, in the light of past experience, what were the advantages and disadvantages of this form of firebox. In consultation with Mr. Nixon, he said unhesitatingly, that what was then known as the "Class I" firebox, which was similar to the camel form, was the cheapest one to build and to maintain, and also the lightest of any in use on the road. If these claims rest upon a sound basis of fact, and are sustained by experience, they are very strong arguments in favor of this form of construction. \* \* \*

"If, then, it can be said that this form of firebox weighs less, costs less and is cheaper to maintain, generates steam freely, and carries water well, it is very strong evidence in its favor."

There was no water space at the rear of the firebox, which was closed in by upper and lower doors, the upper doors being used for firing, and the lower to give access to the grate. When

all these doors were opened, the entire rear end of the firebox was uncovered. The grate bars were of the rocking type, and each grate bar could be rocked independently by inserting a bar in a hole at its rear end. The Winans stack was straight, with an oblong box at its top, from which a "dirt pipe" extended downwardly nearly to the smoke-box and was closed at bottom by a cap. The stack extended nearly to the top of the box, across which iron slabs were set on edge and close together to serve as a spark arrester. This form was, however, soon superseded on the Baltimore & Ohio Railroad by its standard freight engine stack, which is shown in Figs. 26, 27 and others.

Except as to the form and size of the firebox, which was of the inclined top design above described, and as to being slightly heavier, the medium and long furnace camels were similar to the short furnace class. Fig. 32, which is reproduced from an advertising lithograph issued by Ross Winans, about 1852, shows the medium furnace class, and states some of the principal dimensions, giving the weight, with coal and water, as 24 tons. The fireboxes were about 7 feet long by 3 feet 6 inches wide, the grate area being stated as  $24\frac{1}{2}$  square feet. The camel engines of the road were built at various dates between June, 1848, and February, 1854, and (including short and medium furnace types) were the following: "Camel," No. 55; "Iris," No. 59; "Mars," No. 61; "Phoenix," No. 65; "Apollo," No. 66; "Savage," No. 68; "Pilot," No. 69; Nos. 70, 71, 73, 74, 75, 77 to 82 inclusive, 84 to 88 inclusive; 90 to 94 inclusive; 96 to 98 inclusive; 100 to 106 inclusive; 108 to 121 inclusive; 123, 124, 125, 128, 130, 132 to 137 inclusive; 140, 141, 143 to 148 inclusive; 154 to 157 inclusive; 160 to 163 inclusive, and 168 to 197 inclusive.

Ten long furnace camels, Nos. 210 to 219 inclusive, were placed on the road in February, 1857, and were the last of these engines put in service, except three which had been built in 1860 and remained in Ross Winans' shop until 1863, when they were purchased by the Company, which was then in great and immediate need of motive power.

The longitudinal section, Fig. 33, shows that the firebox of these engines was about 8 feet 2 inches long inside, and that a short combustion chamber extending over the rear axle, was provided. It is, however, the recollection of the writer that the fireboxes had only one feed chute, and they had the standard freight engine stack, and not the Winans stack which appears in the illustration.



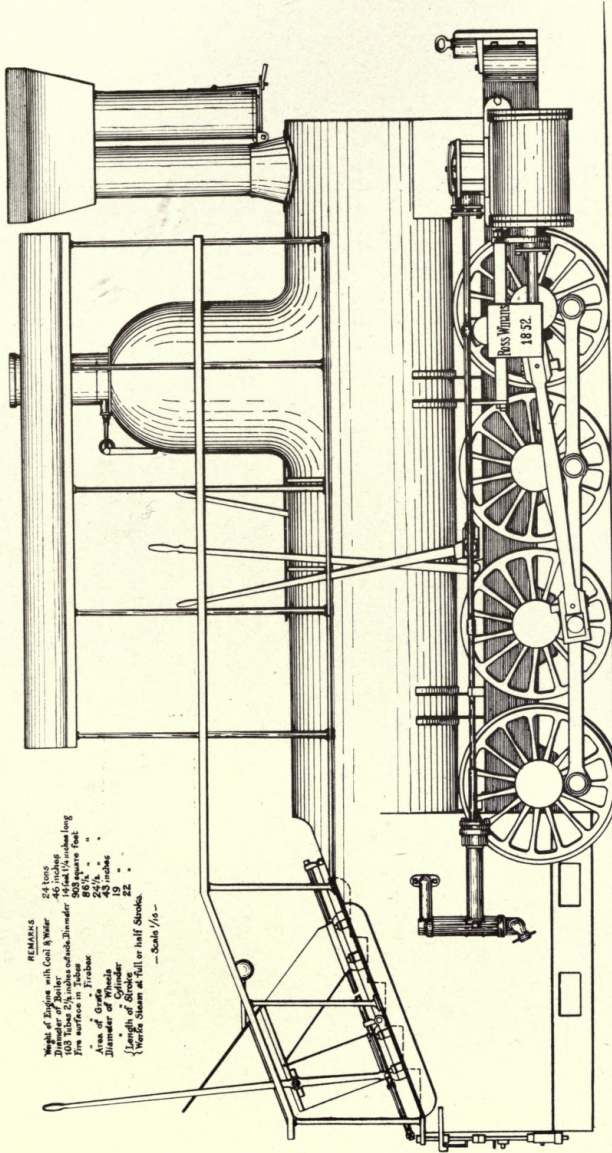

REMARKS  
 Weight of Engine with Coal & Water 24 tons  
 Diameter of Boiler 46 inches  
 (33 Tubes 2 1/2 inches outside diameter) 300 square feet  
 Length of Boiler 86 1/2 " " " " " "  
 Area of Grate 43 square feet  
 Diameter of Cylinder 19 " " " " " "  
 Length of Stroke 22 " " " " " "  
 Weight of Piston at Full or Half Stroke.

— Scale 1/16 —

Transportation Engine, adapted for the burning of Anthracite & Bituminous Coal

MANUFACTURED BY  
**ROSS WINANS**  
 BALTIMORE, MD

Fig. 32.

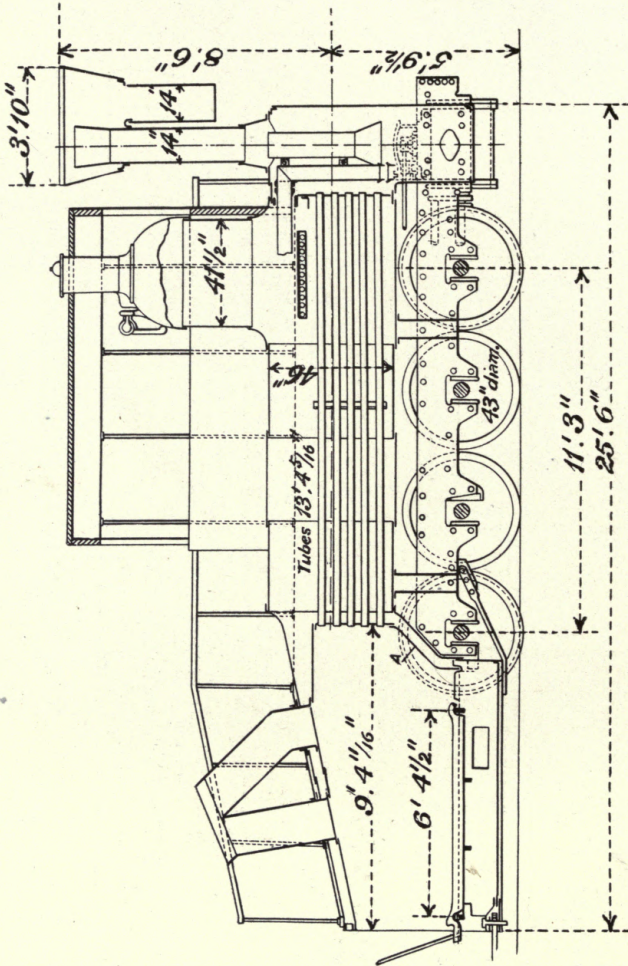

Fig. 33.

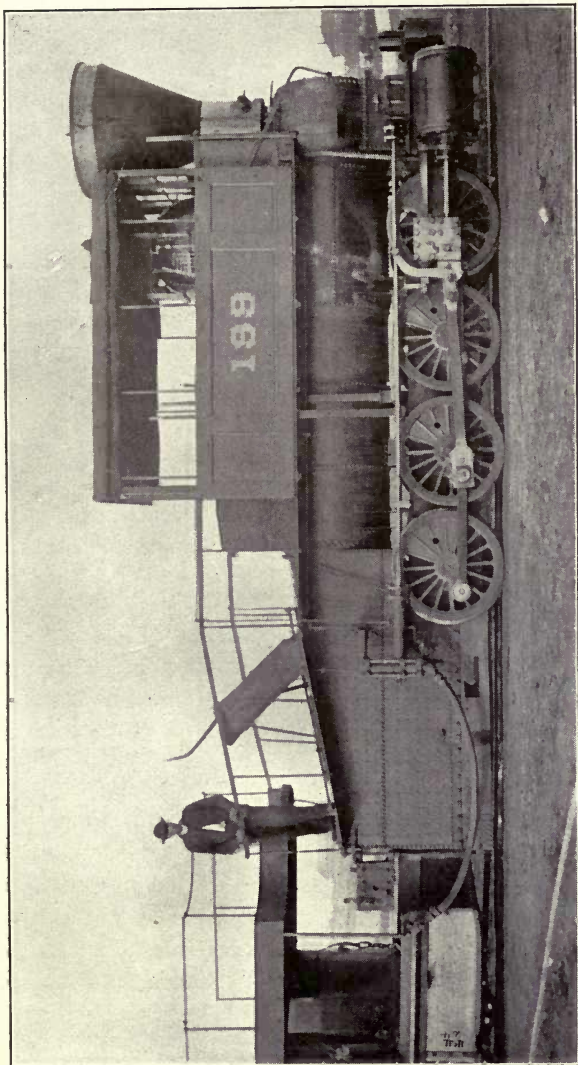

Fig. 34. WINANS' "CAMEL" TYPE

A number of the camel engines were rebuilt by the Company from time to time, and structural modifications were introduced. Among these were an arched top firebox without upper feed chutes; the substitution of Stephenson link valve gear for the original drop hook and cut-off cam gear; the location of the springs above the frames, instead of between the frame slabs; and half stroke pumps, worked from the back crank pins, instead of the cross head pumps. Thatcher Perkins also fitted engine 103, and some others, with new frames, having heavier slabs, planed on both sides, and cast-iron pedestals fitted between the frame slabs and secured thereto by through bolts. This frame was a very substantial, but rather expensive one, and nothing was done at any time to remedy the radical defect of the frame design, which was the absence of a saddle between the cylinders. These were bolted to a flat-sided smoke-box, which was not sufficiently cross stayed, and the resultant looseness at the front end was a constant source of trouble.

The general appearance and proportions of the long furnace camel engines will be clear from the side view, Fig. 34, of engine new No. 199, one of the three that was purchased in 1863. This is reduced from an exceptionally excellent photograph made at Mount Clare, in that year, by the late R. K. McMurray, Chief Inspector of the Hartford Steam Boiler Inspection & Insurance Co., who was at that time in the service of the Machinery Department of the road. Engines 210 to 219 had steps on the sides of the firebox, extending nearly down to its bottom.

Mr. Forney says, in his *American Engineer* article, that "the valve gear would be a curiosity if a drawing of it could be reproduced to day," and his failure to illustrate it was undoubtedly due to the fact that he was unable to obtain one. The only illustration extant of a valve gear of the type used on the camel engines which is within the writer's knowledge—and this differs in some respects from that of the camels—is not a complete one, and is contained in "*American Locomotives*," by E. Reuter, a book which was published in numbers, commencing in 1849; was never completed, and is out of print. The valve gear illustrated by Reuter was that of the engine "Delaware," which was built by Ross Winans, for the Philadelphia & Reading Railroad, in 1847, and which differed from the camels both in being of smaller dimensions and in the location of the dome and cab at the rear, instead of the front, of the engine. Mr. C. H. Caruthers, of Yeadon, Pa., who was, for a number of years, Superintendent of

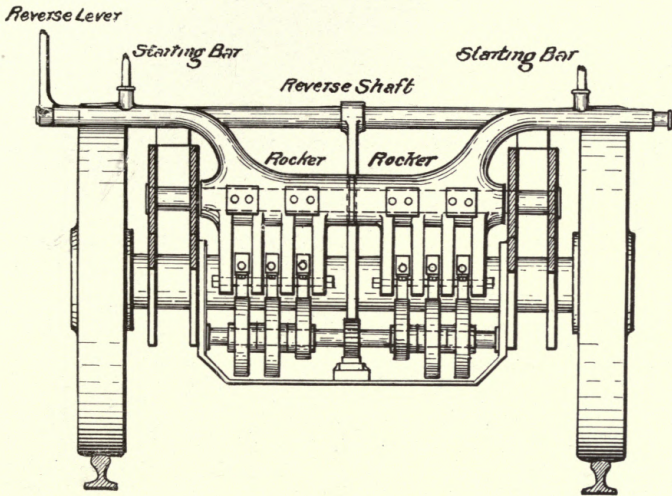

Fig. 35.

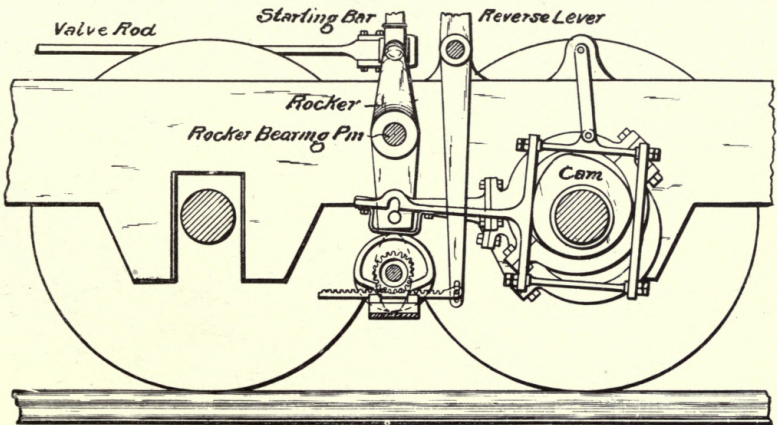

Fig. 36.

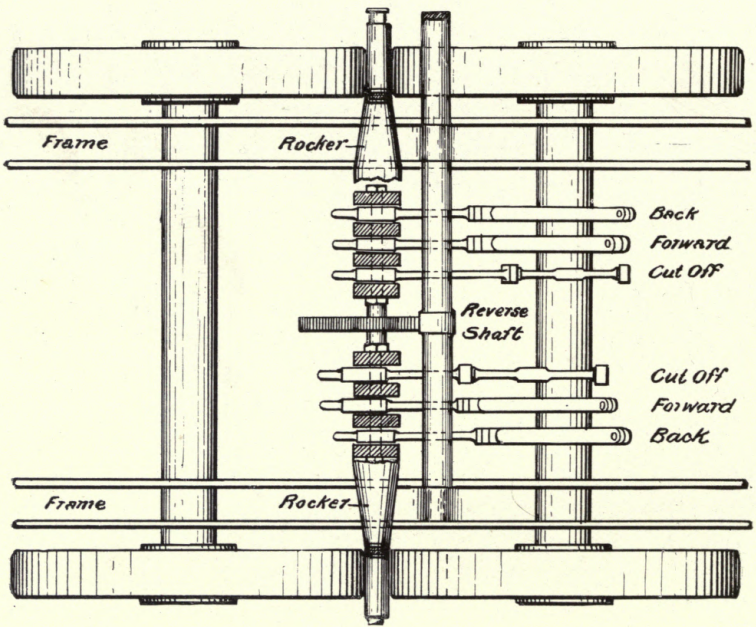

Fig. 37.

the Car Department of the Westmoreland Coal Co., at Irwin, Pa., and was familiar with the camel engines of the Pennsylvania Railroad, has made a very full and interesting set of drawings of them, both in their original form and as rebuilt by John P. Laird, at Altoona, Pa. The writer is indebted to Mr. Caruthers for blue prints of his drawings of the valve gear, from which Figs. 35, 36 and 37, which clearly show its construction, have been prepared.

The camel valve gear was, as shown, of the "drop hook" type, and the valve could be made to cut off at half stroke by a cam, but there was no intermediate range of expansion between full and half stroke. The rockers, which were of cast iron, were journalled to rock on a pin fixed in the frames, and their upper arms projected outwardly across the frames, in goose-neck form, and had pins on their outer ends, to which the valve rods were connected. Sockets were cast on the tops of the upper arms, to receive the starting bars, which extended up into the cab, and when not in use by the engineman, were set in sockets on the tops of the frames. Each rocker had four parallel lower arms, through the lower ends of which the lower rocker pin extended, the rocker arms dividing the surface of the pin into three bearings; the outer one being adapted to engage the notch of the backing eccentric rod; the middle one, the notch of the forward eccentric rod; and the inner one, the notch of the rod of the cam frame (equivalent of an eccentric strap) in which the half stroke cam worked.

The reverse lever was journalled on the top of the right hand frame, and its lower end was coupled to a horizontal rack, which engaged a pinion on a cam shaft carrying three semi-circular cams. These cams stood below the eccentric and cam frame rods, and by the proper movement of the cam shaft by the reverse lever, any selected one of the three rods would be allowed to drop, by gravity, on the lower rocker pin, while the other two rods would be lifted out of contact with the pin. Of course, if the notches of the rods which it was desired to engage with the rocker pins, for forward motion at full stroke, back motion, or half-stroke cut-off, as the case might be, did not happen to stand immediately over the pins, the rockers had to be moved into position for the engagement of the pins and notches, by means of the starting bars.

As may be imagined, the reversal of the engine, or change from full to half stroke, was not a very easy and convenient operation, and it took some skill to successfully fish for the starting-bar sockets from the cab. The valve gear, however, operated well

*valve gear remained on most camlets*

enough to answer its purpose, both in road and yard service, and while, in a number of instances, it was replaced by link motion, yet it remained on most of the camels until they were scrapped.

The present advanced stage of locomotive engineering comprehends, under improved and perfected design, many of the structural features which, in their original and crude form, contributed to make the camel engine the most powerful and effective freight locomotive of its day, but, for reasons which would not appear to be either sufficient, or in accordance with the clear requirements of service, the adoption of the "variable exhaust" has been so limited in extent that it cannot be said to be included in them.

Other improvements of early date have, after a long period of practical abandonment in American practice, been revived and accepted so extensively as to almost become standard, as, for example, the Walschaert valve gear, which was invented in 1844, introduced in the United States by William Mason in 1876, and thereafter, and until a few years ago, neglected and apparently forgotten. Another instance may be noted in the locomotive boiler superheater, all the essential features of which, as now largely and successfully applied, are presented in that of Quillacq and Moncheuil, which was patented in France in 1850, and put in service before 1852, after which it lay dormant until reintroduced by Schmidt in 1898, succeeding which year its application was general and approved, both in Europe and in the United States. It has always seemed to the writer that while a variable exhaust is not, like a variable throttle, essential, it would manifestly be of substantial value, and neither prejudice nor mere errors of structural design should be permitted to exclude it from the standard equipment of a modern locomotive.

So far as shown by any record within the knowledge of the writer, the so-called "variable exhaust," *i. e.*, an appliance for varying the force of the exhaust blast in the stack by the engine-man, was first invented and put into practice by Ross Winans, and it is broadly covered by the claim of his Patent No. 1,868, dated November 26, 1840, which reads as follows:

"I do not claim the plan of increasing the natural draught by causing the steam from the cylinders to enter the chimney through diminished orifices; but I do claim as my invention desiring to secure the same by letters patent, the plan of increasing or diminishing the force with which the steam from the cylinders enters the chimney, at the pleasure of the engineman while the engine is



in use or motion, by enlarging or contracting the orifices of the escape pipes, increasing or diminishing thereby, at pleasure, the draught of the chimney, in the manner above set forth; not intending by this claim to limit myself to the precise arrangement of the respective parts as herein described, but to vary the same as I may think proper, whilst I attain the same end by means substantially the same."

This patent was extended for seven years from November 26, 1854, and was doubtless a source of considerable revenue to Mr.

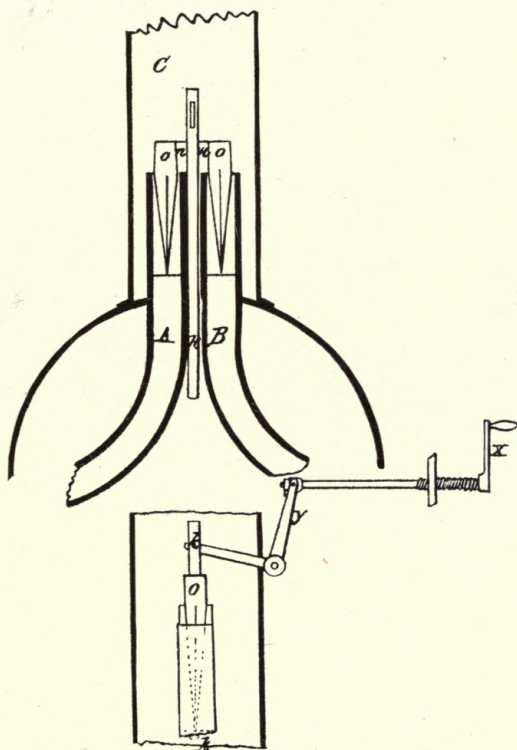

Fig. 38.

Winans, as the variable exhaust, which he applied to the camel engines, met with favor, notwithstanding its operative defects, and was adopted by other builders.

The form of the appliance illustrated in Patent No. 1,868, was, as represented by Fig. 38, which is a reproduction of Fig. 1 of the patent, a conical plug which was movable vertically in the exhaust pipe, to increase or diminish the annular area around it

for the escape of the exhaust steam as desired. This form was used in some of the camel engines of the Baltimore & Ohio and other roads, and comparatively recent instances of it may be seen in European practice. It was also included in the specifications issued by the Company in 1856 for building five ten-wheel engines, which provided that they should be furnished with "variable exhaust operated by a hollow plug."

Another form of variable exhaust, which was the subject of the Winans Patent No. 5,056, dated April 10, 1847, was applied by Mr. Winans to engines built by him prior to the camels, as

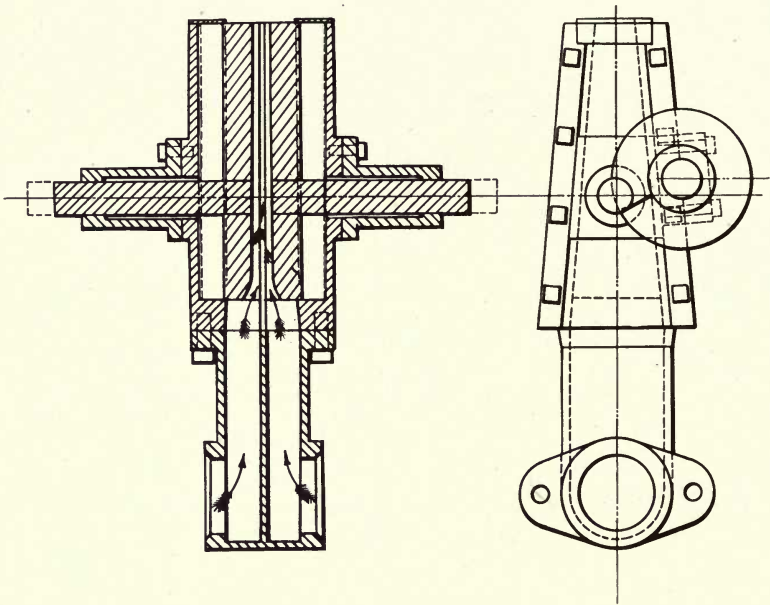

Fig. 39.

well as to the latter engines. This is shown in transverse central section and side elevation by Fig. 39, which is reproduced from Figs. 4 and 5, of Patent No. 5,056.

The exhaust pipes were, in this case, connected to the bottom of a box, in the form of a frustum of a square pyramid, and communicated with openings in the bottom of the box. Two vertical plates were fitted in the box, on stems which projected through its sides, and which could be moved towards and from each other, to decrease or increase the area of the passage between them for the exhaust steam, by a cross shaft carrying worms or screws

which engaged nuts on the stems of the plates, and which was rotated from the cab, through a pair of bevel gears. It will be seen that this construction was one which probably gave good ground for the objection urged against almost all varieties of variable exhaust mechanism, and which appears to have been sufficient to effect their disuse, viz.: liability of the moving parts to become stuck fast in any adjusted position by the heat of the smoke-box and action of oil and cinders.

Another variable exhaust mechanism, which was used on a number of the camel engines, was that of E. R. Addison, who had

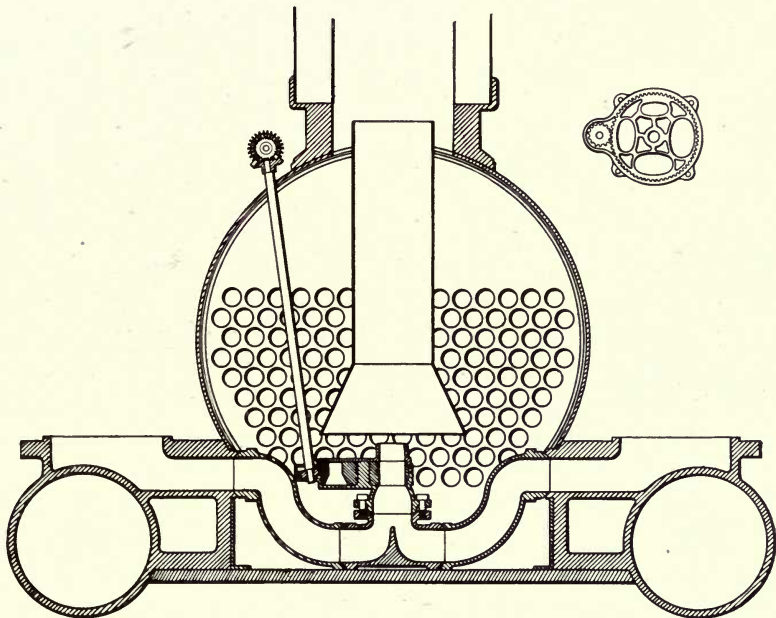

Fig. 40.

been a foreman in Ross Winans' shops and subsequently Master Mechanic at Mount Clare. This was known as the "coffee grinder," and is shown in Fig. 40, which is taken from Mr. Addison's Patent No. 18,373, dated October 13, 1857.

As will be seen from the illustration, this consisted of a circular casting, journalled on a pin in a casing surrounding the exhaust nozzle, and having a number of vertical passages, of different sizes, extending through it, any one of which could be brought into communication with the exhaust pipe, as desired, by rotating the

casting on the pin. The rim of the casting was toothed and geared into a pinion on an upright shaft, which, through bevel gearing, could be rotated by the engineman from the cab.

The camel engines were the last of the 0-8-0 type which were in service on the road during the period covered by this historical review, which would be unduly lengthened by the description of a number of their other features that were, in the words of Colburn, "alike peculiar."

## CHAPTER V.

## THE SIX-WHEEL CONNECTED ENGINES—TYPE O-6-O.

This type, in the motive power in service prior to 1860, included only three engines, all of which were built by M. W. Baldwin. These were the "Baldwin," No. 44, placed on the road in December, 1846; "Wisconisco," No. 50, December, 1847; and "Unicorn," No. 53, February, 1848.

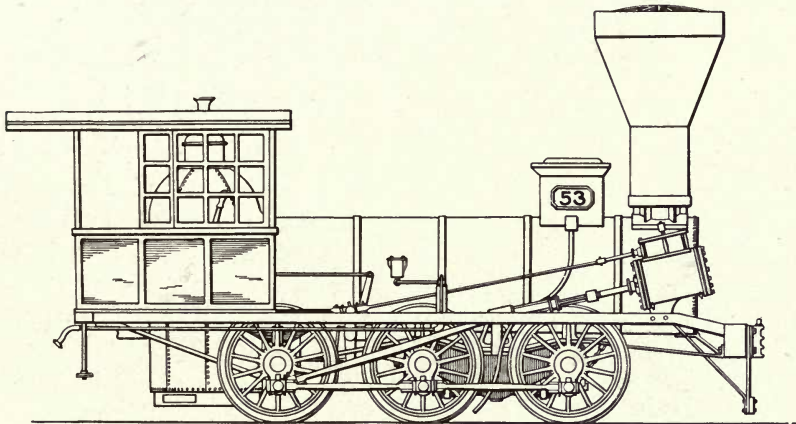

Fig. 41.

They were all of substantially similar construction, which is shown in Fig. 41, a representation of engine No. 53. All of them were fitted with the Baldwin "flexible beam truck" before described, and had driving wheels 43 inches in diameter, and cylinders  $13\frac{1}{2} \times 18$  inches. The boilers of engines Nos. 44 and 50 had 93 copper tubes,  $1\frac{1}{3}$  inches diameter and 11 feet long. The tender was six-wheeled, the forward axle being carried in pedestals on the tender frame, and the two rear axles in a swivelling truck. The tank capacity was 1,200 gallons. The boiler of engine No. 53 was 36 inches diameter, with 101 iron tubes,  $1\frac{1}{4}$  inches diameter, and a firebox  $36\frac{1}{2}$  inches long.

There is no record of the weight of these engines, but an engine of similar class, built by M. W. Baldwin for the Philadelphia & Columbia Railroad, weighed 33,325 pounds, and another, for the Mine Hill Railroad, 32,150 pounds. It is probable that the weight of engines Nos. 44, 50 and 53 was between 32,000 and 35,000 pounds.

## CHAPTER VI.

## THE TEN-WHEEL ENGINES—TYPE 4-6-0.

This type was introduced on the Baltimore & Ohio Railroad in May, 1853, and the early motive power included two classes, the earlier of which was known as the "Hayes ten-wheelers," and the later, the "Tyson ten-wheelers," by reason of being designed, respectively, by the Masters of Machinery named.

## (1). THE HAYES TEN-WHEELERS.

Samuel J. Hayes, who held the position of Master of Machinery from the latter part of 1851 until the Spring of 1856, soon recognized that the operation of passenger trains over the 17-mile grade of 116 feet to the mile, between Piedmont and Altamont, by the ordinary four-coupled road engines, with camel engines as helpers, was not good practice, and reached the conclusion that an engine having a leading truck and embodying, in modified form, some of the features of the camel engines, would be best adapted for this service. He thereupon designed the engines of this character which bore his name, the details of which were worked out, under his supervision, by his assistant, D. P. Rennie; John Cochran, Mechanical Engineer, and W. S. G. Baker, assistant.

As shown in Fig. 42, these engines followed the lines of the camels as to the sloping top firebox, although this was reduced in size, and the cab and dome on top of boiler. They differed, however, from, and were an improvement upon the camels, in having a four-wheeled leading truck, driving-wheels of larger diameter, frames of bar type, which extended past the sides of the firebox, half-stroke pumps worked from the rear crank pins, and independent cut-off valves.

The following description of the Hayes ten-wheelers, which appeared in an article by M. N. Forney, in the *American Engineer and Railroad Journal*, was prepared by W. S. G. Baker, and on account of its completeness and accuracy, is thought to be of sufficient interest to be here repeated:

"The cylinders were 19 x 20 inches, with spring packing and brass rings on the pistons, the piston rods being of iron,  $2\frac{3}{4}$  inches diameter. The steam ports were  $1\frac{1}{2}$  by 14 inches, the exhaust port  $2\frac{1}{2}$  by 14 inches, and the travel of the valve  $4\frac{1}{2}$  inches.

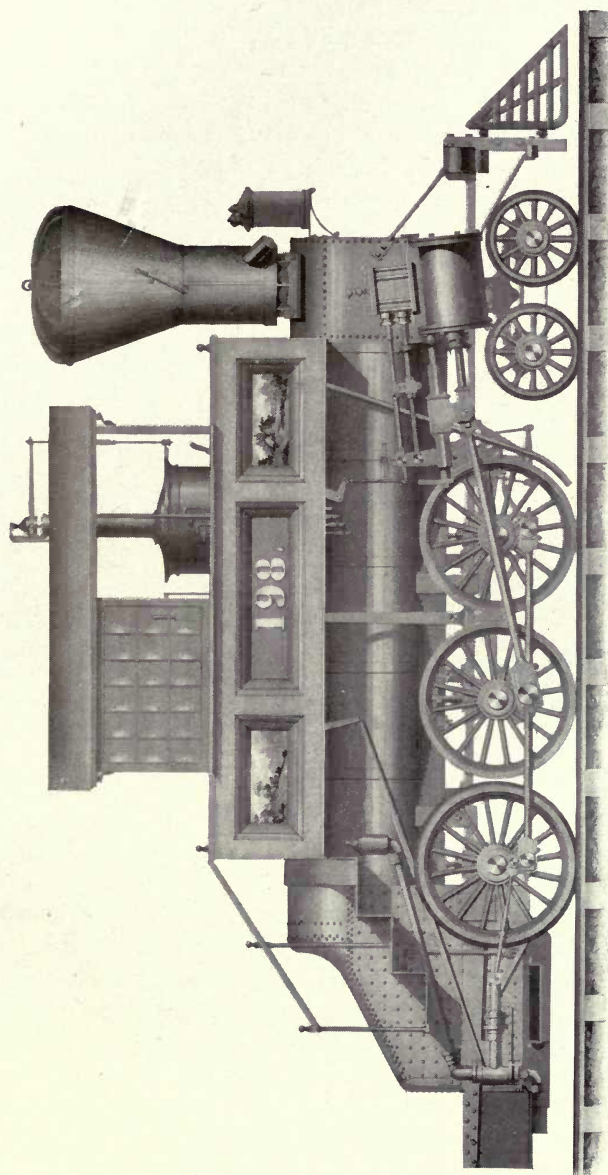

Fig. 42.

The crossheads were made of brass, with gun-metal gibs at the top and bottom, arranged with bolt and wedge-shaped tops to take up wear. The guide rods were of wrought iron, and of diamond section. The main rods led to the centre driving-wheels and were 7 feet 7 inches from centre to centre. The tires for the main and leading drivers were  $6\frac{1}{2}$  inches wide and blind, the rear drivers having flanges. The centres of all the drivers were of cast iron, fitted with chilled-faced cast-iron tires, put on with a taper fit and held by lateral hook keys and nuts.

"The driving-wheels were 50 inches diameter and 52 inches from centre to centre. The truck-wheels were 28 inches in diameter, with chilled faced, placed 36 inches, centre to centre, and the centre of the truck was 15 feet 8 inches from the centre of the rear driving-wheels. The main axle was  $5\frac{1}{2}$  inches in diameter, the others being 5 inches. The total weight of the engine was 60,000 pounds, about 48,000 pounds being on the drivers.

"The truck bolster was of wrought iron, with its centre forged on, the journals formed at the ends and fitted into housings resting upon and keyed to semi-elliptic springs, 36 inches long, the ends of which rested and slid within seats formed on top of the truck frames. The frames were of wrought iron, with the pedestal jaws forged on. The jaws were slotted to shape and fitted with cast-iron shoes and wedges adjustable from below. The axle boxes were of gun metal and the springs were semi-elliptic, graduated. They were equalized upon the main boxes and were connected to the boxes by pins passing through the frames upon which the springs rested. The frames were rigidly secured to the smoke-box but were free at the firebox end and so arranged that the boiler was free to slide upon them and was held in place by sleeves passing around the frames and bolted to the firebox.

"The boiler was horizontal and straight. It was 48 inches in diameter, with single rivetted seams, and was made of  $\frac{5}{16}$ -inch iron. The dome was 30 inches in diameter and 36 inches high, with a cast-iron flange and top made with a ground joint. The safety valves were formed in the top and connected by a lever to a spring balance. The dome was placed 54 inches back of the front flue sheet. The firebox was of copper, with  $\frac{5}{16}$ -inch sides and  $\frac{5}{8}$ -inch flue sheet. It was 42 by 58 inches in size and there were 160  $2\frac{1}{4}$ -inch flues of lap-welded iron 14 feet 4 inches long.

"The feed-water was supplied by two single-action pumps attached to the sides of the firebox and operated by cranks attached



to the crank pins of the rear driving-wheels. The feed-water entered the boiler by checks immediately in front of the back flue sheet, and was then conveyed by a pipe inside the boiler and discharged immediately back of the front flue sheet. Rocking grates were used, operated by a lever on the foot-board, with a drop-grate in front. The drawbar was attached to the ashpan as in the Winans camel engines.

"The valve gear was of the hook type, with cut-off worked at half stroke, and operated by a separate eccentric and rocker. The valve stem of the cut-off was so arranged that it could be thrown out of gear, the valve remaining stationary when the cut-off was not used.

"Steam was taken from the top of the dome through a slide-valve throttle, operated by a crank connected to a screw with large pitch. The gage cocks were in the waist of the boiler below the foot-board of the cab and operated by long stems and levers. The pilot in front of the engine was so arranged that it could be folded back when not on the road. This was done to permit of closing the doors of the engine house when the engine was in the stall. The smoke stack was arranged for soft coal fuel. It was formed with a centre pipe 12 inches in diameter, over which a cast-iron deflector was placed. This was to deflect sparks into a hopper formed by a second pipe, with a space between it and the central one. This space was provided with an outlet at the bottom to facilitate the removal of accumulated sparks. The top was provided with a bonnet hinged to the stack and covered with iron netting."

The performance of these engines, both in the passenger service for which they were originally designed, and in freight service, was efficient and satisfactory, an evidence of which is the fact that over twenty years after their introduction, a considerable number of the same class, modernized by the application of link motion valve gear and wide spread trucks, were built in the Company's shops, and used until displaced by heavier motive power.

The Hayes ten-wheelers in service prior to the year 1860 were seventeen in number, and were constructed at the dates and by the builders stated in the following list, viz.:

No. 129, July, 1853, and No. 138, May, 1853, A. & W. Denmead & Sons; No. 139, May, 1853, New Castle Manufacturing Co.; No. 142, May, 1853, and No. 158, July, 1853, Smith & Perkins; Nos. 159 and 165, July, 1853, No. 166, August, 1853, and No. 167, September, 1853, A. & W. Denmead & Sons; No. 198,

December, 1854, B. & O. R. R. Co.; No. 199, November, 1853, and No. 202, January, 1854, A. & W. Denmead & Sons; No. 203, January, 1854, B. & O. R. R. Co.; No. 204, March, 1854, and No. 205, April, 1854, A. & W. Denmead & Sons; No. 206, June, 1854, B. & O. R. R. Co.; and No. 209, November, 1854, A. & W. Denmead & Sons.

(2) THE TYSON TEN-WHEELERS.

Henry Tyson, who succeeded Samuel J. Hayes as Master of Machinery, was appointed in June, 1856, and remained in office until some time in 1859. Early in his administration he designed a class of ten-wheel engines of more modern construction than the Hayes ten-wheelers, being those known as the "Tyson ten-wheelers," the drawings for which were made by M. N. Forney, who was employed as chief draughtsman at Mount Clare, after the close of his apprenticeship in the shops of Ross Winans, and it is hardly necessary to say that these drawings were of the same grade of excellence as uniformly characterized Mr. Forney's work. Mr. Tyson, if not an active opponent of the camel engines, as was probably the fact, was not, in any degree, an advocate of them, and his new design did not embody any of their characteristic features. As a result, a personal controversy, in which considerable feeling was manifested on both sides, was inaugurated between him and Mr. Winans, as to the relative merits of the camel and ten-wheel engines. This was carried on in pamphlets and newspaper articles by the parties, and was determined in favor of Mr. Tyson, so far, at least, as may be judged from the facts that nine of his ten-wheel engines were built for the Baltimore & Ohio Railroad, and that no more camel engines were thereafter built for the road, although, as before stated, the Company, under the pressure of war times, purchased three of them that had remained in stock in Mr. Winans' shop since 1860.

The beginning of this controversy was the following note, which was sent to Mr. Winans by Mr. Tyson:

"Office Machinery Department,  
Baltimore & Ohio Railroad.  
Baltimore, September 13, 1856.

"Dear Sir:—This Company propose to contract for the building of five ten-wheel locomotive engines, according to designs to be furnished by them. They are to weigh thirty tons with water in boiler and fuel, to have cylinders 18 inches diameter and 24

inches stroke, 50-inch drivers, 30-inch truck-wheels, with link motion and variable exhaust.

"Inform me at an early day if you desire to make a bid for the whole or a portion of the contract, and at what time the machines could be delivered. Specifications will then be sent you.

"Yours, etc.,

"HENRY TYSON,

"Master of Machinery.

"To Ross Winans, Esq."

Upon receipt of this note, Mr. Winans called upon Mr. Tyson, and after urging upon him the superiority of the camel engine, Mr. Tyson states that he declared emphatically that *he would not build a ten-wheel engine*, but at a subsequent interview, stated that he had concluded to send in a bid for building these engines upon his own design. Mr. Tyson did not await this bid, but sent to Mr. Winans, and to other locomotive builders, the following request for bids for the engines, and accompanying specifications:

"Office Machinery Department,  
Baltimore & Ohio Railroad.  
Baltimore, *September 27, 1856.*

"ROSS WINANS, ESQ., *Baltimore, Md.*

"Dear Sir:—The Baltimore & Ohio Railroad Company desire you to bid for the building of five first-class locomotive freight engines, to be constructed according to the dimensions and design shown in the enclosed specifications.

"Should you receive the award, a detailed specification and all necessary drawings will be furnished at once.

"Your bid will be for thoroughly first-class machinery, both as regards material and finish, and will state the time of delivery.

"Very truly yours,

"HENRY TYSON,

"*Master of Machinery.*

"*Specifications for Building Five First-class Locomotive Freight Engines for the Baltimore & Ohio Railroad Company.*

"The weight of each engine to be thirty tons (60,000 lbs.) with water in boiler.

"The material used in their construction to be of the best quality, and the workmanship to be of the most perfect description.

"The boiler to be plain wagon-top; the cylinder part to be 48 inches at firebox and 46 inches at smoke-arch, 14¼ feet long, outside dimensions; the firebox, outside dimensions, at top, 74½ x

48 $\frac{3}{4}$  inches; inside dimensions, 66 x 41 inches, and 57 $\frac{1}{2}$  inches deep; the smoke-arch, 46 $\frac{7}{8}$  inches diameter by 36 $\frac{1}{2}$  inches long on outside; the tubes, 125 in number, 2 $\frac{1}{8}$  and 2 $\frac{3}{8}$  inches outer diameters, length 14 feet 3 $\frac{1}{2}$  inches. The inside of firebox to be of copper, except the crown-sheet which is to be of iron; the crown is to be supported by vertical bolts  $\frac{7}{8}$  inch diameter, tapped through the outer shell of boiler and crown-sheet, with nut underneath and rivetted on ends. The iron in boiler and tubes to be made from charcoal blooms after the most approved mode of manufacture.

"The driving-wheels, six in number, 50 inches diameter, with hollow spokes and chilled cast-iron "slip-tires"; the back drivers to be flanged, the middle and forward ones smooth, all to work in front of firebox.

"The cylinders, 18 inches diameter and 24 inches stroke; their position to be horizontal; the steam-valves to be operated by stationary links, and rockers.

"The frame to be made of a solid bar of 3 x 4 $\frac{1}{2}$ -inch iron, to be flattened to 1 $\frac{1}{4}$  x 8 inches to pass the sides of the firebox and extend to support the foot-board and receive the draught-bar. The pedestals to be 15 inches long and 3 inches wide and forged solid to the frame, the top and sides of the frame are to be planed smooth; the feet of pedestals are to be planed to receive the brace. The inside and sides of pedestal jaws are to be furnished with wrought-iron facings planed and accurately finished to receive the brass boxes.

"The truck wheels to be (Bush & Lobdell's) 28 inches diameter and 68 inches apart from centre to centre; the frame to be made of rectangular bars of wrought iron, with cast-iron pedestals properly fitted and secured by bolts and braced to receive the weight on side bearings; distance from centre of back driver to centre of truck pintel, 15 feet.

"The engines to be furnished with cast-iron steam pipes, and variable exhaust operated by a hollow plug. All bolts to be turned and fitted, the heads and nuts of bolts of parts that require frequent adjustment to be case-hardened, the dimensions and threads of these bolts to be made according to sample. The cylinder part of boiler to be covered with  $\frac{3}{4}$ -inch hemlock lagging and cased with Russia iron.

"The tender tank to be of 2,000 gallons capacity; the top, sides and bottom to be secured by 1 $\frac{1}{2}$  x  $\frac{1}{4}$ -inch angle iron and

$\frac{3}{8}$ -inch rivets, securely braced; the trucks will be similar to those used for the engines except that the wheels will be 50 inches apart from centre to centre.

"These engines to be delivered to the Company in the city of Baltimore, in perfect running order, with all tools and appurtenances necessary for their operation, subject to the approval of the Company's Master of Machinery.

"The payments to be made in cash after each machine has been delivered and successfully operated on the road for thirty days, satisfactory guarantee being given that the Company will be reimbursed for any damage from accident that may arise from defect in material or imperfect construction during the first six months of their service."

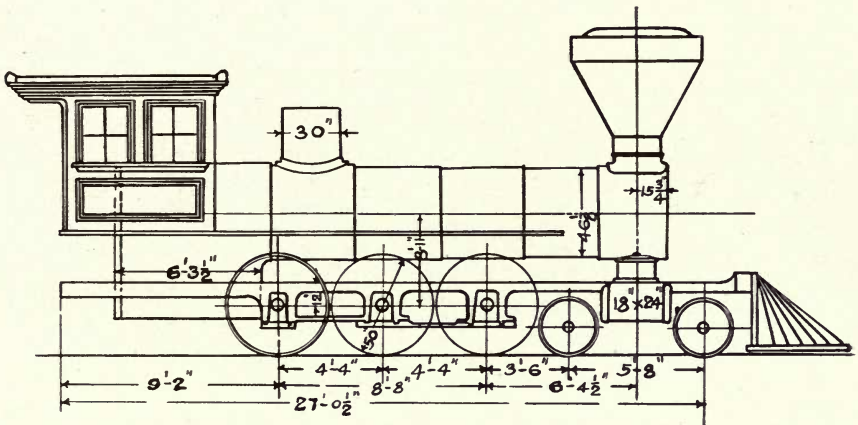

Fig. 43.

These engines, as subsequently built under the above specifications, are shown diagrammatically in Fig. 43, from which it will be seen that they differed from the camels, not merely in the substitution of a four-wheeled leading truck for the front pair of driving-wheels, but also in the absence of all the structural peculiarities of the camel engines. They were the first engines of the road on which the Gooch, or so-called "stationary" link motion was applied, and except the eight Mason engines, before described, which were ordered by Mr. Tyson, were the first that had round smoke-boxes supported on bed-plates, subsequently called "saddles," connected to the frame and cylinders.

Mr. Winans, who had always been an opponent of the ten-wheel type, did not submit a bid in accordance with the specification, but made one which, as stated in one of Mr. Tyson's pam-

phlets, "offered to build a camel engine in all respects, except that it was to have a truck in place of the front driving-wheels; conforming in no wise to the description of machine he was asked to bid for, except as to the *number of wheels.*" His bid was in the following terms:

"October 4, 1856.

"HENRY TYSON, ESQ., Master of Machinery,  
Baltimore & Ohio Railroad Company.

"Dear Sir:—Yours of the 27th of last month, expressing a desire of the Baltimore & Ohio Railroad Company that I should bid for the building of five first-class locomotive freight engines to be constructed according to the dimensions and design shown in the specifications enclosed in your letter to me, is received.

"I will furnish the five engines and tenders required by said Company during the month of January next for the sum of \$10,000 per engine and tender, provided you will allow me to deviate from the specifications in the following particular, to wit: The size of the wheels (43 inches), and the valve-gear and frame of the engine to be similar to the eight-wheel engines I heretofore furnished the Company, the boiler to be on the general plan of the boilers of the eight-wheel engines.

"I will conform to the specifications in all other particulars that may be consistent with the above proposed alterations. This, I feel quite sure, will make as good if not better ten-wheel engines than can be had by following the specifications strictly, and by being allowed to make these alterations, I can furnish the engines some two months earlier than I otherwise could.

"Respectfully, etc.,

"ROSS WINANS."

This offer was at once rejected by Mr. Tyson, and a contract was awarded to A. & W. Denmead & Sons, by whom seven of the engines were built, and two more were built by the Company at Mount Clare. The Denmead engines were Nos. 222 and 223, April, 1857; No. 224, July, 1857; No. 225, August, 1857; No. 226, September, 1857; and Nos. 227 and 228, December, 1857. The engines built by the Company were Nos. 229 and 230, September, 1857.

Fig. 44 shows one of the Denmead engines, which were similar to those built by the Company. From the illustration, it would appear that the engine from which it was made, had the freight engine pattern of stack, but those of the Company's build had the passenger engine stack shown in Fig. 43.

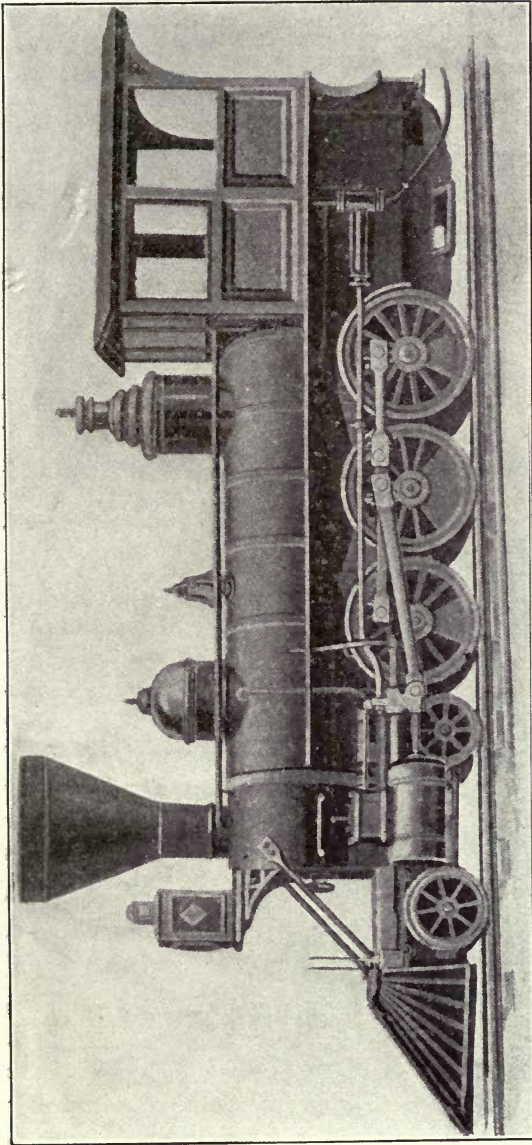

Fig. 44.

The Tyson ten-wheelers were obviously better adapted for fast freight service, for which they were designed, than the camels, and, generally speaking, were efficient machines, although objection was developed in their operation, by reason of a supposed insufficiency of weight on the truck, which was believed to be the cause of comparatively frequent derailments, and, in some cases, heavy cast-iron plates were fitted over the frames, in front of the cylinders, to impose additional weight on the truck. It is not entirely clear why this objection should have been made, or that it was well-founded, as these engines had as much weight on their trucks as, or a little more than, the Hayes ten-wheelers, as to which no fault had been found in this respect, but nevertheless the facts are as stated.

The pamphlets which were issued by the parties in the camel vs. ten-wheel engine controversy indicate the widest possible difference of opinion between the advocates of the respective classes of engines, and some of the matter which they contain is of sufficient interest to warrant its reproduction and comparison with present approved practice. The earliest of these publications is believed to be a pamphlet of 34 pages, entitled "*A Communication to the President and Directors of the Baltimore & Ohio Railroad Company, by Ross Winans, on the subject of Locomotive Engines for the Transportation of Freight on Railroads. Baltimore: Printed by John D. Toy, 1856.*" Mr. Winans' claims of the greater efficiency and economy of the camel, as compared with the ten-wheel engines, are stated with practical fulness, in the following extracts from this pamphlet, the preface of which indicates it to have been prepared "a few days" after the receipt, by Mr. Winans, of Mr. Tyson's request for bids for ten-wheel engines, dated September 13, 1856, which has been previously quoted.

In his prefatory address to the President and Directors, Mr. Winans, with his characteristic strength of opinion and force and directness of expression, says:

"Being under the most thorough conviction of the decided inferiority, for your purpose, of the ten-wheel engines, having six drivers only in its best possible form or state, as compared with an eight-wheel engine of equal weight, all the wheels being drivers—I say, being under this conviction, I could not consent to build ten-wheel engines for the purpose of transporting freight on your road, even though you gave me all your engines to build, and although I might make greater profits on them, without insisting



that they were decidedly inferior to the eight-wheel engine for your purpose."

The relative cost of repairs and "average useful effect" of the two classes of engines are stated in the body of the "Communication," as follows:

"On the Baltimore & Ohio Railroad the freight business has been done with two kinds of locomotive engines, one of which has six driving-wheels and a four-wheel truck, usually called the ten-wheel engine, the other has eight wheels, all of which are driving wheels. Most of the eight-wheel engines on your road have been built by myself and are usually called the camel engines. There is now, and has been for the last three years on your road, seventeen of the ten-wheel engines, and one hundred and nine of my build of camel engines.

"The object of this communication is to call the attention of the Company to the result of the experience in the transporting of freight by these two kinds of engines, as furnished by the Company's Reports, and to make a comparison of their efficiency and economy for such purpose.

"In the following comparison, I have taken fourteen of the seventeen ten-wheel engines on the Baltimore & Ohio Railroad.

"These fourteen engines have been used mostly for the transportation of freight trains. The other three have been used during the years 1854 and 1855 for the running of passenger trains exclusively. The repairs of which three engines, per mile run, has been 42 per cent. less, and the distance run per year, 46 per cent. more than has been the case with the same description of engines employed in running freight trains. The passenger trains being lighter than the freight trains, puts less stress on the engine, and hence, the less repairs in proportion to miles run, and the less repairs detains the engines a less time in the shops, hence, the greater distance run by engines of the same description, when employed in running light instead of heavy trains, as is shown in this case, and by the general experience on railroads.

"For the above reasons and from the fact that the engines on your road, and of my building (known by the name of the camel engines), have, with slight exceptions, been used for running freight trains exclusively, it would be unfair to bring the three above-mentioned engines into this comparison. I shall, therefore, leave them out, and hereafter in speaking of the ten-wheel engines have reference to the before-mentioned fourteen engines.

“The cost of repairs, herein given for the different engines, embrace those occasioned by accidents and casualties of all kinds, and for rebuilding, renewal, etc.:

109 CAMEL ENGINES.

Whole distance run by all of the Camel Engines on the Baltimore & Ohio Railroad (109 in number) from their first introduction on the road, to October 1, 1855, to the date of the Company's last Report ..... 5,402,899 miles

Cost of Repairs for the above number of miles run by the 109 Camel Engines.....\$503,353.66/100

Average distance run per engine, per year, by the 109 Camel Engines ..... 17,074 miles

Average cost of Repairs, per mile run by the 109 Camel Engines ..... 9-31/100 cents

14 TEN-WHEEL ENGINES.

Entire distance run with freight and passenger cars, by the 14 before-mentioned *ten-wheel Engines* on the Baltimore & Ohio Railroad, since their first introduction on the road in 1853, to the 1st of October, 1855, to the date of the Company's last Report:

Miles run with Freight Trains..... 406,553 miles

Miles run with Passenger Trains..... 63,251 miles

Total number of miles run..... 469,804 miles

Cost of Repairs for the above number of miles run with the *ten-wheel Engines*..... \$44,514.83/100

Average distance run, per engine, per year, by the *ten-wheel Engines* ..... 15,701 miles

Average cost of Repairs, per mile run by the above *ten-wheel Engines* ..... 9-47/100 cents

53 CAMEL ENGINES.

Fifty-three Camel Engines, which are of the same age as the before-mentioned ten-wheel Engines, having been put on the road at the same time, to wit: in 1853, and beginning in 1854.

Distance run by the said 53 *Camel Engines*, from the time they were put on the road up to October 1, 1855, the date of the Company's last Report ..... 1,907,197 miles

Cost of Repairs for the above miles run by <i>Camel</i> Engines .....	\$161,037.25/100
Average distance run, per engine, per year, by the said 53 <i>Camel</i> Engines.....	17,281 miles
Cost of Repairs per mile run by the 53 <i>Camel</i> Engines .....	8-44/100 cents
Average distance run, per engine, per year, by the <i>ten-wheel</i> Engines .....	15,701 miles
Cost of Repairs per mile, run by <i>ten-wheel</i> Engines	9-47/100 cents

"In comparing the cost of the repairs and useful effect of the camel engines with that of the ten-wheel engines, the only true practical result is had by taking into account the distance ran and the load taken by the respective engines. It is, therefore, important in this comparison to bear in mind that the camel engines have one-third more in number of propelling wheels, one-third more weight on the propelling wheels, one-third more steam generating power, and consequently one-third more tractive force than the ten-wheel engines. Consequently the comparative amount of load which can be drawn by the respective engines, as an extreme effort on a single occasion, is in the proportion of three to four. Upon this it might at first view be inferred that the practical average everyday loads of the different engines might, and consequently had been in that proportion to each other, say eighteen cars for the ten-wheel engines, to twenty-four cars for the camel engines, and that with this difference in the loads, the distance traveled per year by each description of engines should be the same, and, therefore, that the ten-wheel engines had, on an average, done three-fourths as much work in a year as the camel engines. This, however agreeably to the Company's Reports, and the information I have received in relation to the size of trains taken by the different engines is very far from being the fact.

"The ten-wheel engines being deficient not only in the size of the train taken, but also in the distance ran per year by them, and this is not the case for one year only, but for each and every year they have been on the road. Now this uniformity of experience, year after year, is not the result of accident, but results from good and sufficient causes, among which causes are the following: The camel engines, notwithstanding they have one-third more propelling wheels, are decidedly less complicated, in their general plan and in their details of construction, and have a less

number of joints, journals and working parts liable to wear, derangement and breakage than the ten-wheel engines. The lesser number of the working parts of the eight-wheel engine and its general simplicity and straightforwardness of construction enables all the parts to be made more substantial and durable than the parts of the ten-wheel engine, while the entire weight of the two kinds of engines are the same. These are among the means by which the camel engines have been enabled to do a much greater quantity of work per year than the ten-wheel engines, and at the very much less cost of repairs in proportion to the work done, as here shown. It may be asked why the number of miles run by the ten-wheel engines per year should be materially less than that of the camel engines, as is shown to be the case by the Company's Reports. The reason is obvious. The greater liability of the ten-wheel engines to derangement kept them in the shops more of the time for repairs and adjustment.

"Again, it may be asked, why the trains of the two different kinds of engines should not in practice have been in the proportion to the proportionate weight on the driving wheels of the respective engines. That is to say, eighteen cars for the ten-wheeled engines to twenty-four cars of the camel engine—here the reason again is plain. If the ten-wheel engine with trains of but little over half the size as appears to be the case of those taken by the camel engines, have cost more for repairs per mile run than the camel engines, it (and the fact of their having one-fourth less adhesive and tractive force) shows them ill-fitted for doing the coal or other heavy freight business of the road, consequently they have been kept at lighter work without relieving them, however, from greater cost of repairs. I am informed by the men who run, and the conductors of the trains of the ten-wheel engines, that the way trains on which these engines are mostly worked, average about ten cars throughout the trip, the stock and other trains on which the ten-wheeled engines are worked, in part, are larger than ten cars, and from the best information I have on the subject, varies from fourteen to eighteen cars and may average sixteen cars—the distance ran with passenger trains by the said fourteen ten-wheel engines is about one-seventh of the whole distance run by them—these trains consist of not more, if as much, as seven cars. If the whole distance run by the ten-wheel engines be divided as follows: One-seventh with passenger, four-sevenths with way freight, and two-sevenths with stock or other through

freight trains, and the average number of cars in the trains be, passenger, seven; way freight, twelve, and stock or through freight, eighteen, the general average, embracing all the trains, will be thirteen cars per train.

“This is, I am persuaded, a larger number than is warranted by the facts of the case, but I shall, in the absence of positive information in relation to it, take thirteen cars as the average size of the trains of the ten-wheel engines.

“I also understand that the camel engines are worked almost exclusively on the coal and other heavy through freight trains, and that it is the common practice for six or eight of these trains to leave Martinsburg for Baltimore, with about twenty-one cars attached to each engine; that on the trains arriving at Mount Airy, which is about half the distance to Baltimore, two of the six, or three of the eight engines, go back to Martinsburg, leaving the balance of the engines to bring to Baltimore, in addition to their own trains, the trains of the engines which return to Martinsburg. This, in the case of six engines leaving Martinsburg, would give an average of thirty-one and a half cars per engine from the Ridge to Baltimore, and an average of twenty-six cars between Martinsburg and Baltimore, or, say, twenty-four cars as a general average. A similar practice of doubling the trains (as it is called) prevails on portions of other sections of the road, with the heavy through trains, and I presume with similar results as regards the average of the loads taken by the camel engines.

“If I am rightly informed on this subject, and I think no material error exists, it follows that the loads of the camel engines have, in practice, been nearly double that of the ten-wheel engines. Therefore, as before mentioned, the true comparative cost of repairs and of the useful effect of the different engines can only be arrived at when the difference in their loads is taken into account as well as the difference in the distance traveled per year by them respectively.

“In the Company’s Reports this has not been done, nor has it been done in the results derived from the reports heretofore given by me, and I now propose to take this difference of load and difference in distance traveled into account, basing the calculation on the differences in the loads of the engines here before mentioned, to wit: Thirteen cars for the ten-wheel engine and twenty-four for the camel engines, and upon the cost of repairs and number of miles run, shown in the Company’s Reports.

“Average useful effect produced per engine per year, equal to the following number of long cars hauled one mile:

By the 14 ten-wheel Engines.....	204,113
By the 53 Camel Engines.....	414,744

“This is the proportion of 1 to 2, or 100 per cent. in favor of the camel engines, or, in other words, one camel engine has done as much work per year, as two ten-wheel engines.

“Average cost of repairs due to the hauling each long car 100 miles by each kind of engine:

By the 14 ten-wheel Engines .....	72-84/100 cents
By the 53 Camel Engines .....	35-16/100 cents

“This is in the proportion of 1 to 2, or 100 per cent. in favor of the Camel Engine.

\* \* \* \* \*

“Useful effect produced per engine per year equal to the following number of cars hauled one mile:

By the ten-wheel Engines.....	235,515
By the Camel Engines.....	345,620

“This is in the proportion of 1 to 1-47/100, or 47 per cent. in favor of the camel engine, or two camel engines would do as much as three ten-wheel engines.

“Average cost of repairs due to the hauling of each long car one hundred miles by each kind of engine:

By the ten-wheel Engine.....	63-13/100
By the Camel Engine.....	42-20/100

“This is in proportion of 1 to 1-49/100, or 49 per cent. in favor of the camel engines.

“Since writing the foregoing, I have procured the Company’s Report, dated October 1, 1856. This furnishes another year’s experience in the working of the different kinds of engines here being compared. The result of which further experience, I propose to add to that of the experience here before given in relation to the working of these engines:

109 CAMEL ENGINES.

Whole distance run by all of the Camel Engines on the Baltimore & Ohio Railroad (109 in number), from their first introduction on the road, to October 1, 1856, to the date of the Company’s last Report .....	7,437,896 miles
Cost of Repairs for the above number of miles run by the Camel Engines.....	\$738,962.33/100

Average distance run, per engine per year, by the 109 Camel Engines .....	17,483 miles
Average cost of Repairs per mile run by the 109 Camel Engines .....	9-93/100 cents

## 17 TEN-WHEEL ENGINES.

Whole distance run with freight and passenger cars by all the ten-wheel Engines on the Baltimore & Ohio Railroad (17 in number), from their first introduction on the road, to the 1st of October, 1856.

Miles run with freight trains.....	616,826 miles
Miles run with passenger trains.....	259,011 miles
Total number of miles run with freight and passenger trains by the 17 ten-wheel Engines	875,837 miles
Cost of Repairs for the above number of miles run with the ten-wheel Engines.....	\$90,272.62/100
Average distance run, per engine per year, by the 17 ten-wheel Engines .....	16,937 miles
Average cost of Repairs per mile run by the above ten-wheel Engines .....	10-31/100 cents

In connection with the foregoing statements of performance of the two classes of engines, Mr. Winans presents, at considerable length, his arguments in support of his claim of the superior efficiency of the camels. While some of these, particularly as to the advantage of a large firebox, will be recognized as well founded, modern practice has so thoroughly demonstrated the desirability, if not the absolute necessity, of a leading truck, in a road engine operating at the speeds at which freight service is now ordinarily conducted, that the Company's decision, at the early date of 1857, to substitute the ten-wheel engine for the camel, will be recognized as a correct one, and as being entirely in accord with the results of later experience.

Mr. Winans, with obvious correctness, specifies the following as being "among the causes which enable trains to conform most nearly to the time-tables on roads," viz.: *First*, a large surplus of steam generating power in the engines, to be always in readiness to gain any time lost by unforeseen occurrences; *second*, the presence of the greatest practicable amount of adhesion of the driving wheels, consistent with a due regard for the preservation of the road"; *third*, a large surplus cylinder power so as to enable the use of the surplus adhesive and surplus steam generating power;

and, *fourth*, the greatest practical freedom from such derangement of the machinery or other parts of the engine as to cause delay or stoppage on the road. He then says:

"Now, I confidently assert that the camel engines, by which very much the larger portion of your freight business is, and has been done, combine the before-mentioned properties to an extent and in harmony with each other and with the whole economy of freight transportation on railroads, far in advance of any other description of engine that has been built in this or any other country."

In support of this assertion, the pamphlet calls attention to the following features of the camel engines, which are claimed by Mr. Winans to be of special advantage:

The weight of the engine, is twenty-six tons, distributed almost equally on eight driving wheels, being three and a quarter tons on a wheel, furnishing "a very large practicable amount of adhesion together with due regard to the preservation of the road." The weight on each driving wheel is stated to be "less than is the case with most of the engines now in use, even those of very inferior power and efficiency."

The cylinders are nineteen inches in diameter and twenty-two inches stroke. These cylinder dimensions, taken in connection with the unusually small diameter of the driving wheels (43 inches) give "a larger amount of cylinder power in proportion to weight of engine than can be found on any locomotive engine in this country, except the same description of engines of my make on other roads, and this is true while the cylinders are comparatively light, growing partly out of their simple construction and mode of being secured in place, and partly out of the greater effective capacity given to them by the small size of the propelling wheels."

"Economy of weight without diminished durability" is claimed by the stopping of the frames in front of the firebox, "which facilitates the increasing of the size of the firebox, and enables the frame to be much lighter, while the proper strength is secured." The fireman's position being on the tender, the engine is relieved from the weight of a foot-board, as well as from the weight of the elongated frame for its support. "Here again unnecessary weight is saved."

The side rods are of a peculiar construction (solid end), resulting in "unusual lightness and security against derangement while in action, and are proof against having their length changed so as to be dangerous—ordinary side rods being very liable to



have their length changed to such extent as to cause great stress, derangement and breakage to crank pins and other parts of the engine."

The springs (four in number) "serve the double purpose of springs and levers for distributing the weight equally upon the wheels, and are new in their construction and in their mode of being secured in place, and are at once simple, light, and efficient as compared with the springs of the ten-wheel engines, which are six or eight in number, much more complicated in their make and mode of securing in place, and much heavier, and have much of their action taken away by bands around their middle.

"With a view to avoiding each pound of unnecessary weight, the boxes resting on the journals of the driving wheel axles are made in one piece and entirely of brass, instead of being made of two pieces, one of iron and one of brass, as is usual."

The small size of the wheels makes them, as propelling wheels, comparatively light, being not more than two-thirds the weight of ordinary size driving wheels, when of equal strength and durability, and the smaller wheels involve less strength of axles, all of which produces a saving in weight. The proportion of the small sized driving wheels to the piston stroke "materially diminishes the stress put upon all the working parts, fulcrums, and abutments, through, and by means of which, the steam power is exerted to propel the train, consequently all these parts do not require to be so massive and heavy, to meet and withstand the stress which they can be subjected to, as would be the case with larger propelling wheels and equal tractive force. The truck of the ten-wheel engine, with its frame, wheels, axles, boxes and bolster is a worse than useless appendage to a freight engine, inasmuch as it takes away from the power of the engine, as compared with one of equal weight, all the wheels being drivers, and adds weight to the engine without corresponding benefit."

Mr. Winans' statements in this pamphlet as to the advantages of the form of boiler designed and applied by him in the camel engines, have been, in their more important particulars, affirmed to be correct by the results of later experience and present standard practice. They are of sufficient interest to be inserted at length, and will be found to be, in general, approved by the expressions of M. N. Forney, quoted in the chapter on the 0-8-0 engine:

"The camel engines have a more powerful boiler than any locomotive engines before built, in proportion to the entire weight of engine. This is dependent partly on the fact that the general

plan, arrangement and construction of the machine as a whole, and of each of its separate parts, is such as to admit of a much larger portion of the entire weight of the machine being put in the boiler, and partly growing out of the construction of the boiler, and the arrangements connected therewith for the making of steam, being such as to furnish unusual steam generating power, in proportion to the weight of the boiler itself, the fireplace has twenty-four square feet of grate surface, and a correspondingly large space for fuel—this is much larger than common, and is most important to the rapid generation of steam. The fireplace is made upon a plan much lighter than an ordinary locomotive boiler. The inner roof of the fireplace is the same distance from the outer roof that the inner sides are from the outer sides of the fireplace, and the roofs are stayed and bolted together in the same manner that the sides are staybolted, giving remarkable lightness and safety.

“The external dimensions of the fireplace in its cross-section is much smaller than usual, being just sufficient to allow of the proper space for fuel and blaze of fire, and the proper water space between the inner and outer shell of the fireplace—this, together with the peculiar staying of the roof of the fireplace, with a short (instead of long) staybolts, or with heavy bars across it in the usual way, economizes weight both in the material of boiler, and in the water contained in it, so as to enable, with the forward position of the dome and house on top of the boiler, a very material increase of fire-grate, while an equal distribution of weight on the wheels is bad. This large fire-grate is of the utmost importance to the successful and economical burning of coal.

“To add to the steam generating power of the boiler, peculiar facility is given to the fireman, by means of rocking grates, and his position on a low foot-board, to keep the fire-grates and ashpan free from cinder and ashes.

“Again, the engineman, by means of the variable exhaust (which is peculiar to my build of engine) increases or diminishes the intensity of the fire at his pleasure, and is thus enabled to generate more or less steam as he may require it.

“Since important advantages result from the introduction of small wheels, in the plan and arrangement of the camel engines, it may be asked, is there any counteracting disadvantages resulting from their use in said engines? As a freight engine, there is certainly no want of speed. There has been a tendency, on all roads where these engines have been used, to make more speed

with them than was allowable for freight trains. The redundancy of steam always at command, constantly tempted the engineman to run ahead of time, even with the largest loads assigned to the engines. So much so has this been the case that it has been proposed to curtail the steam generating power of these engines by making their fireplaces smaller. This is the first proposition to diminish the steam generating power in locomotive engines that has come to my notice, the strife now being, throughout the country, to get sufficient power in coal burning engines, and resort had to various complicated and unusual construction of boilers, to accomplish the purpose which, as yet, has only been done with partial success, while I have, with the ordinary and well-tested plan of boiler, by means of unusual quantity instead of complication, succeeded to an extent second to no engine using whatever kind of fuel. This is due, in an important degree, to the before-mentioned general plan of the engine, and the plan and construction of its several parts, by means of which a systematic economy of weight, throughout the entire machine, is had, thereby allowing of the more powerful boiler in proportion to weight of engine.

"If one of the reasons for proposing to diminish the fireplace of the camel engines now on your road shall be that some of the first ones put upon the road have smaller fireplaces than those since furnished, and that the smaller fireplaces endure better and require less repairs than the large ones, and that, therefore, the proposed diminution is to save expense in repairs—just the reverse of this should be the fact, all things, other than difference of size in fireplace, being equal. To generate equal quantities of steam, in equal time, in small as in large fireplace boilers, involves a higher temperature of fire in the small fireplace than in the large. This more concentrated and greater intensity of heat is unquestionably more destructive to the surrounding material of the fireplace than would be the milder temperature in the larger fireplace.

"The fifty-three camel engines, heretofore mentioned, are the last lot put upon the road; these have large fireplaces and have more adhesion, more cylinder, more steam generating power, and have run more miles per year, and since their power is greater, it is fair to infer, with heavier trains; yet, with all this, the expense of repairs, including that of fireplace, is less per mile run than that of the first lot here mentioned, which embraces the small fireplace engines. This is shown by the Company's Reports.

"Ten per cent. enlargement of the fireplace of these engines adds more than ten per cent. to their generating power and

capacity to burn coal; therefore, if this power and capacity be abused by profuse and wasteful blowing-off of steam, or by the allowing of excessive leakage between the pistons and cylinders, or in any other way, the large fireplace permits abuse to be carried to a greater extent, and consequently more injury to be done than is the case with the small fireplaces—this was proved by the much greater leakage in the tubes in the large fireplace boilers. This greater leakage was remedied at my suggestion, by the Company's taking measures to stop the unnecessary blowing-off of steam at the safety-valve of these engines, and not by making the fireplaces smaller.

“And the object which has been assigned for shortening the fireplace of these engines (if it has any really serious foundation) can be accomplished without the necessity of seriously and permanently injuring the machines, as would be the case by shortening the firebox. In fact, the object has been accomplished by one of my recent improvements in these engines, which the better guards against the abuse or misuse of their large fireplace and redundant steam generating power.

“The fact of the abundance of steam always at command has enabled these engines to make time and be used successfully when their pistons were very leaky, and consequently has led to the practice of so using them even at the expense of increased deterioration of fireplace and expenditure of fuel.

“The improvement above alluded to is to give unusual facility for keeping the pistons tight and such facility as it is confidently believed will induce their being kept tight, and thus accomplish the end aimed at without shortening the fireplace.

\* \* \* \* \*

“The large fireplace of these engines enables abundance of steam to be generated with a much more open or large exhaust orifice than is usual. The variable exhaust enables full advantage to be taken of this fact. All the steam and the exhaust pipes are unusually large (five inches internal diameter).”

Mr. Winans next presents what he considers to be the advantage of the valve motion of the camel engine and compares it with the link motion proposed to be applied in the Tyson ten-wheel engines, which latter, as might be expected, he disapproves of. Referring to the camel engine valve motion, he says:

“The valve face openings are large, equal to fifteen square inches. And the valve movement is such as to give these large openings their full effect and benefit, even when the steam is

being cut off at such portion of the stroke as to expand one hundred per cent. or to twice its original bulk, and are such as to keep the exhaust end of the cylinder open until the piston has arrived at two inches from the end of a twenty-two-inch stroke, when the steam is being expanded in the cylinder to the extent above mentioned.

"These things combined give the steam free and rapid action through the steam passages, valve openings, and exhaust, and with but slight holding back by the compressed steam on the reverse side of the piston. With these advantages the camel engine readily makes thirty miles per hour, notwithstanding that the speed of the pistons is more rapid than usual for such speed of engine."

He then makes the following comparison of the camel engine valve motion with "the best constructed link motion," which he assumes to be that of passenger engines built by Rogers, Ketchum & Grosvenor, of Paterson, N. J., having cylinders sixteen by twenty-two inches, and steam opening in valve face equal to 16.71 square inches.

"When the steam is cut off at such portions of the stroke as to get the advantage of the steam expanding 100 per cent., or to double its original bulk before being exhausted from the cylinder, the greatest area of the effective opening through the valve face into the cylinder is equal to  $5\frac{43}{100}$  square inches, or less than one-third of the entire area of the effective opening when the engine is being worked at full stroke, and slightly over one-third the effective valve openings into the cylinder of the camel engines, when the steam is so cut off by them as to give the benefit of 100 per cent. expansion. Again, the link-motion movement, when the steam is being cut off, so as to allow of 100 per cent. expansion, closes the exhaust opening when the steam piston lacks  $7\frac{1}{2}$  inches of being at the end of the stroke; this gives threefold more back pressure, or retarding force on the reverse side of the piston, than that which takes place in the camel engines when steam is being expanded—100 per cent. by each kind of valve gear.

"The above properties of the link motion render it a very imperfect cut off when the steam is to be expanded to any considerable extent, more especially when applied to freight engines, the cut-off being most needed when the draught is the hardest; at which time any curtailment of the cylinder power in freight engines, beyond that which is necessary to the using of the steam expansively, is decidedly objectionable. What I mean by the curtailment of the cylinder power will be better understood by the

following explanation: the advantage of 100 per cent. expansion of steam is enabled to be availed of in the camel engines when the steam is cut off at 10 inches of the stroke of the piston, and the exhaust commences when the piston has arrived at  $1\frac{1}{8}$  inches of the end of the stroke, and the exhaust opening of the other end is closed when the piston has arrived at 2 inches from the end of the stroke. With the link motion, and 22-inch stroke of piston to avail of 100 per cent. expansion, the steam is cut off when the piston has traversed  $9\frac{3}{8}$  inches of its stroke, and the steam has commenced to exhaust when the piston has arrived at  $3\frac{1}{2}$  inches from the end of the stroke, and the exhaust opening, at the other end of the cylinder, closes when the piston is  $7\frac{1}{2}$  inches from the end of the stroke. The exhausting of the steam, in the link motion engines,  $2\frac{3}{8}$  inches earlier in the stroke, curtails the power of the cylinders 11 per cent., as compared with the camel engine arrangement and cut-off.

"In addition to the foregoing, the very great compression of steam, on the reverse side of the piston, resulting from the link motion cut-off, causes a still further curtailment of the cylinder power, and involves a greater positive loss of steam power, from the compressed steam not giving back all the power which was taken to compress it, as compared with the camel engines, amounting, in all, to probably 20 per cent. more curtailment of cylinder power, by the use of the link motion, to cut off steam as early as before mentioned, than is the case with the valve gear used on the camel engines.

"In the foregoing comparison, I have taken the cut-off at that part of the stroke which gives the benefit of 100 per cent. expansion of steam in both kinds of valve movements. I have done this because I have found, from long experience, that it is important to cut off steam as early as this, in a first-class coal-burning freight engine.

*First*—Because the steam generated is used more economically.

*Second*—Because less fine coal is drawn through the tubes and thrown out of the smoke-stack; and,

*Third*—Because the boiler is subjected to a less intense heat, and is less deteriorated than would be the case if the steam was cut off later in the stroke. The result of all this is, that the link motion is poorly adapted to a first-class coal burning freight engine. Over the hard parts of the road, with heavy trains, is the time when the 100 per cent. expansion of steam is most useful and is most needed, and when the large steam passages, to permit free

passage of the steam into and out of the cylinders, is most important; and the time when any unnecessary curtailment in the cylinder power can be least afforded. An early cut-off, full steam openings, and full power of cylinder, should be had acting together. In the camel engines such is the case—in the link-motion engines, very far from it.

“That which has had most to do with bringing into use, and keeping into use, the link motion on locomotive engines, is the facility which it affords of reversing an engine, when running at great speed, without liability of failure. The importance of this, for passenger engines, has induced the use of the link motion on them, notwithstanding the very inefficient cut-off afforded by it. To freight engines, and especially to those intended for burning coal, the importance of a good and early cut-off, acting in conjunction with open and free steam passages, and uncurtailed cylinder power, is of so much more consequence than the certainty of reverse furnished by the link motion, as to make the link motion wholly out of place on coal-burning freight engines. It should be borne in mind that the slow speed of the freight engines relieves the want of any more certainty of reverse for them than is furnished by the valve gear connected with the best description of cut-off for freight purposes, which best description of cut-off movement has the further advantage of being less expensive and difficult to keep in repair and adjustment, than the link-motion cut-off.”

Mr. Winans concludes his “Communication” as follows:

“I do not pretend that the camel engines may not be improved. I am constantly engaged with a view to their improvement and have recently made important improvements in them, but the proposed alterations before mentioned would, if made, be decidedly injurious instead of beneficial to them.

“It is perhaps not improper that I should mention, before closing this paper, that the general plan and combination as well as most of the detail peculiarities of the camel engines has been devised by myself and patented.”

In accordance with a resolution of the Board of Directors of the Baltimore & Ohio Railroad Company, at a meeting held February 11, 1857, a pamphlet of 58 pages, on the relative advantages of the camel and ten-wheel engines, was prepared under the direction of Mr. Henry Tyson, Master of Machinery, and published by the Company. This pamphlet, which presented the ten-wheel engine side of the controversy, was entitled,

"PAPERS  
 Relative to the Recent  
 CONTRACT FOR MOTIVE POWER  
 By the  
 BALTIMORE & OHIO RAILROAD CO.  
 and the  
 REPORTS OF THE OFFICERS OF THE DIFFERENT  
 DEPARTMENTS  
 On the Relative Advantages of the  
 WINANS CAMEL ENGINE  
 and the  
 TEN-WHEEL ENGINE  
 For the Various Branches of their Service.

---

Baltimore.  
 Printed by James Lucas & Son,  
 No. 19 S. Calvert St.  
 1857."

The preliminary portion of this pamphlet comprises a recital of the personal controversy between Mr. Winans and Mr. Tyson, and copies of the letter and specifications for the building of five ten-wheel engines, which have been previously fully stated in this chapter. The remainder of the pamphlet consists of the Reports of the Masters of Machinery, Transportation, and Road, to the President, together with letters to these Department officers from subordinates, expressing their opinions as to the relative merits of the two classes of engines. The general tenor of the communications of the Machinery Department officials is indicated by the following extracts from the Report of Mr. Tyson:

"The 'Camel' engines, of which this Company own 109, are characterized by general peculiarities of construction, in which they differ from other locomotive engines; the most of these peculiarities have been patented by their inventor. They have eight wheels connected together in such a manner as to receive the power of the engine equally on each, forming a rigid and unyielding mass, which has to be accommodated to the curvatures of the road by the force of the flange of the front wheel against the outside rail. Their boiler is also singularly constructed, with a firebox of unusual length, without any support except where it is joined to the cylinder part of the boiler.

"The years of experience which this Company have had in the use of the 'camel engine' have shown them to possess many dis-



advantages; and but one advantage can be claimed for them, which is common to all eight-wheel connected engines, and that is a greater degree of adhesion, enabling them to draw, under favorable circumstances, a load 12 per cent. heavier than a 'ten-wheel engine' of the same weight, but with more than a proportionate consumption of fuel, and at a much slower speed. They are very roughly and cheaply built, and disproportionate in many parts; consequently, they are expensive to keep in repair. The forcing or impingement of the flange of the front wheel (the axle of which is kept rigidly at right angles to the frame of the engine) against the outer rail, in passing curves, causes a great wear upon the rail and flange, and if a slight defect exists in the road, or if the engine is propelled at a fast speed through curves, switches or irregularities, it is certain to displace the rail or break the flange and leave the track. Scarcely a week passes in which casualties of this kind do not occur; two have taken place during the past week; the damage in each case will not be less than one thousand dollars. This peculiarity, which is also common to all eight-wheel connected engines, renders them unsafe and more liable to leave the track than engines furnished with a vibrating truck, which serves to guide them smoothly around the curves. The boiler of the 'camel engine' has been a source of continued trouble; the overhanging weight of the 'firebox' without support causes it to crack where it joins the cylinder part, making constant watchfulness and frequent patching of the parts necessary to prevent explosion. The flues and seams in the furnace require to be caulked very frequently; it is difficult to keep them tight under any circumstances. This renders them unreliable, and often causes trouble and detention on the road; it is by no means an unusual occurrence for one of these engines to start with a full load, with the boiler tight and in apparent good condition, and after proceeding some miles, it will commence leaking and soon become inefficient. It is then necessary to take the train to the nearest 'siding,' where it remains until another engine can be procured, and the disabled engine is hauled to its station. The records of the transportation department will show that these failures often result in serious obstruction to the road. The engines of this description recently furnished the Northwestern Virginia Road I consider inferior to those formerly built for this company—they have already proved defective in many parts, and material alterations will have to be made in them if they are continued in the service.

"The 'ten-wheel engines,' of which this Company own 16, have always proved remarkably safe and reliable. The passenger service is exclusively performed by them on the third, or mountain division, and the greater number of them are also kept in the freight service on this division, owing to their being considered safer and more reliable on the heavy grades than any other engine. They are furnished with six driving-wheels connected, to which the power is applied, the rear ones only being flanged; the front portion of the engine is sustained by a vibrating truck. They have a furnace of sufficient size to generate an abundant supply of steam. They are suited to any branch of the service, and can be run at high speed with passenger trains with entire safety—one of their particular characteristics being their certainty to remain upon the track. I have never known one to leave the track, except when it has met with a formidable obstruction."

Mr. Tyson's Report also contains tables of relative performance and cost of repairs of the two classes of engines, stated to be prepared from the Company's Reports, which are uniformly in favor of the ten-wheel engines.

Many of the objections urged against the camel engines, in these reports and letters, were doubtless well founded, and perhaps all of them obtained to a greater or less extent, but it is manifest that a reasonable allowance must be made for prejudice and exaggeration on the part of the writers. That the camel engines were harder on track and wheel-flanges than the ten-wheel engines, is beyond question, but it is doubtful whether they were subject to other objections to the extent indicated by the letters of subordinate officers of the Machinery Department, or that the ten-wheel engines compared as favorably with them, as to hauling capacity and cost of repairs, as is stated in the various papers included in the pamphlet. Mr. David P. Rennie, Assistant Master of Machinery, makes the statement, which is entirely at variance with present practice, that "The very large firebox on these engines [long furnace camels Nos. 210 to 219] is also a disadvantage on account of its capacity to hold a greater than necessary amount of fuel required for the service they are capable of performing. This renders them by no means economical, as they will consume more fuel than necessary for the amount of work done," etc. Mr. E. R. Addison, Master Mechanic at Mount Clare, concurs with his associates in condemning the camel engines, and, in his letter, makes the following remarkably strong statement as to the advantage of the variable exhaust:

"I consider that the ten-wheel engines in perfect construction, durability and economy in repair and fuel, far surpass the camel engines. The only advantage possessed by the latter engines over the ten-wheel engines is the variable exhaust; and if these are placed on the ten-wheel engines, I believe they would cost 10 per cent. less for fuel, and 100 per cent. less for repairs of furnaces than the camel engines."

The expressions of the Masters of Transportation and Road, and their subordinates, are all decidedly in favor of the ten-wheel engines, and are to the effect that they are safer, less liable to leave the track at speeds of from 15 to 25 miles per hour, better adapted for stock and passenger service, and much less destructive to the track. Mr. W. S. Woodside, Master of Transportation, says:

"Without undertaking to give an opinion of the mechanical arrangement of these engines [camel and ten-wheel], or to enter into details of their relative performance on the road, I would state that I consider them both valuable machines. The eight-wheel engine, for heavy freight upon a substantial straight road, at moderate speed, may be regarded as a machine of great traction and power; but, for a curved road like ours, I consider it much more destructive to the track than the ten-wheel engine. The ten-wheel engine, from its peculiar construction, has shown itself to be very efficient, by its adaptation to various uses in a service like that of the Baltimore & Ohio Railroad. It is peculiarly adapted to the stock trains and other fast freight trade, and from its capability of safety, making a speed of twenty-five miles per hour, it is especially valuable as a passenger engine in cases of emergency. For the heavy mountain grades it is almost exclusively employed in hauling the passenger trains."

Mr. W. Bollman, Master of Road, referring to "the cost of keeping the track in proper adjustment," says:

"As to the exact difference of cost of repairs, if all the engines had truck wheels in front, it would be difficult to say, but I am of opinion it would be at least 15 per cent."

One of the subordinate officers of the Road Department considers that the Company would "at least save 20 per cent." in track repairs, if it had all ten-wheel engines; others estimate the saving at 25 per cent.; a Road Supervisor thinks that "the iron would last as long again with the ten-wheel engines as it would with the camel engines"; and another says that "if the Company had all ten-wheel engines, the iron in the track would last a third

longer, and in the end the amount of repairs to the road would be 25 per cent. less than they are at present."

Mr. Winans replied to this publication, by a pamphlet of 64 pages, the title page of which reads as follows:

"ADDRESS  
to the  
PRESIDENT AND DIRECTORS  
of the  
BALTIMORE AND OHIO RAILROAD COMPANY,  
on the Subject of  
LOCOMOTIVE ENGINES,  
and the Errors in Relation Thereto, Contained in a Pamphlet  
Recently Published by Authority of the Company.

By ROSS WINANS.

Baltimore.

Printed by John D. Toy.

1857."

This pamphlet reviews that of the Company above considered; presents Mr. Winans' version of the communications between Mr. Tyson and himself; makes further comparisons of the performance of the camel and ten-wheel engines, "according to the facts recorded in the Reports of the Company," as well as upon data presented by Mr. Winans; and concludes with a "Proposal for a Scientific Commission" to investigate and report upon "the questions at issue." Further arguments in favor of the camel engines and "Evidence of Practical Experts" as to their performance appear in an Appendix.

In support of his request for the appointment of a Scientific Commission, Mr. Winans makes the following pathetic appeal to the President and Directors of the Road:

"My heretofore prosperous business, in the prosecution of which so many hundred of persons have been supported, has been so prostrated as to render it not sufficiently encouraging to pursue it further—unless I can counteract the ill effect of Mr. Tyson's abuse of your name and influence, and by a proceeding to which you are parties, establish the injustice to which I have been subjected, and vindicate the reputation of those machines, to whose peculiar properties, I have the authority of the very founder of your Board for saying, you owe the largest measure of your prosperity.

"And this result has been brought about at a time when I find myself with a large amount of capital invested in the means of carrying on my business, and a large investment in camel engine, finished and unfinished, without orders or a prospect of sale of them; or the means of turning the large capital invested in my business to account without great loss and sacrifice."

This request was not, however, complied with, and as before stated, no more camel engines were built for the road, the Company having apparently accepted, as final, the position taken by the heads of its operating departments as to the undesirability of this type of engine.

Without assenting to the charge of Mr. Winans, that Mr. Tyson occupied the position of the "innovator" to whom he refers, he forcibly and correctly portrays in the following remarks, which are as appropriate to-day as when they were written, the distinction between useful and practical invention and the crude schemes of incompetent and inexperienced experimenters.

"But the crowning piece of machinery connected with the railroad is the locomotive. But for this great conception, the railroad must have remained comparatively on a level with those imperfect modes of transportation with which mankind for so many centuries had been obliged to be content. The man whose inventive genius can impart new power to this great agent, or usefully improve or modify the discoveries of others, undoubtedly deserves applause and encouragement, and I should be the last man in the world to withhold my approval from any plan of improvement which, founded upon sound mechanical principles, promises to give increased efficiency to this right arm of all railroad operations. But, there is a vast difference between the pretensions of the real mechanic, who surveys, with the eye of science and experience, the works of others, marks their defects and seeks to amend them, and the rash innovator who, at the expense of others, puts his own science, skill and ingenuity in competition with the whole world, and regardless of results, and indifferent to the interests of his employers, places everything at hazard for the chance of realizing, out of his crude conceptions, a reputation for himself."

Mr. Winans maintains that in dealing with the question of the wear on rails and cost of repairs of track, there should be taken into account, 778 eight-wheel coal cars, "the axles of which remain parallel, the same as the camel engines, and the distance between the extreme axles is within a few inches as great as that of the

camel engines, and consequently produce the same kind of shearing or rubbing of the flange of the wheels against the rails of the road as Mr. Tyson attributes to the camel engines. This, however, would seem to be in support of the claim of superiority of the ten-wheel engine as to being less injurious to the track. He also charges the injury to track to be more largely due to passenger engines and cars, as to which he says:

"Science and theory point to the passenger engine and passenger car as having, from the effect of their much greater centrifugal force, had much more to do with wearing the inner edge of the outer rail of the curves, and displacing the rails from their legitimate position, than the action of freight engines and cars on the road at their appropriate speed. An examination of the flanges of the passenger cars and passenger engines, and a comparison of their wear with that of the flanges of the freight cars and engines, will show conclusively that experience has verified what science dictated."

Fig. 44a is a full size reproduction of a diagram appearing opposite page 47 of this pamphlet, showing the flange sections of camel engine tires as originally applied, and as subsequently put on by Mr. Tyson, the line F B E representing the form and depth of the original tires and the line F C E the form and depth of the latter. As to this he says:

"I have before called the attention of the Board to the fact that Mr. Tyson commenced some months since to put wheels under the camel and the other eight-wheel-connected engines on your road, with flanges of such shape and dimensions as materially to increase the liability of the engines using them to run off the track, as compared with the wheels originally put under the camel engines by me. The flanges of the wheels procured by Mr. Tyson at Wilmington for the engines are about one-fourth of an inch less in depth, and about one-fourth of an inch more bevel or flare, as compared with the original wheels put under the camel engines. (See diagram hereto annexed.) And each of these differences increases the liability of the engines to run off the track, and their influence, collectively, is such as to be of very serious importance, as has been fully demonstrated by the practical experience of the Company, and shown by what here follows."

It may here be noted that the height of the present standard flanges of the road is only *one inch*, and that driving wheels are now being successfully operated having tires only seven-eighths of an inch in height.

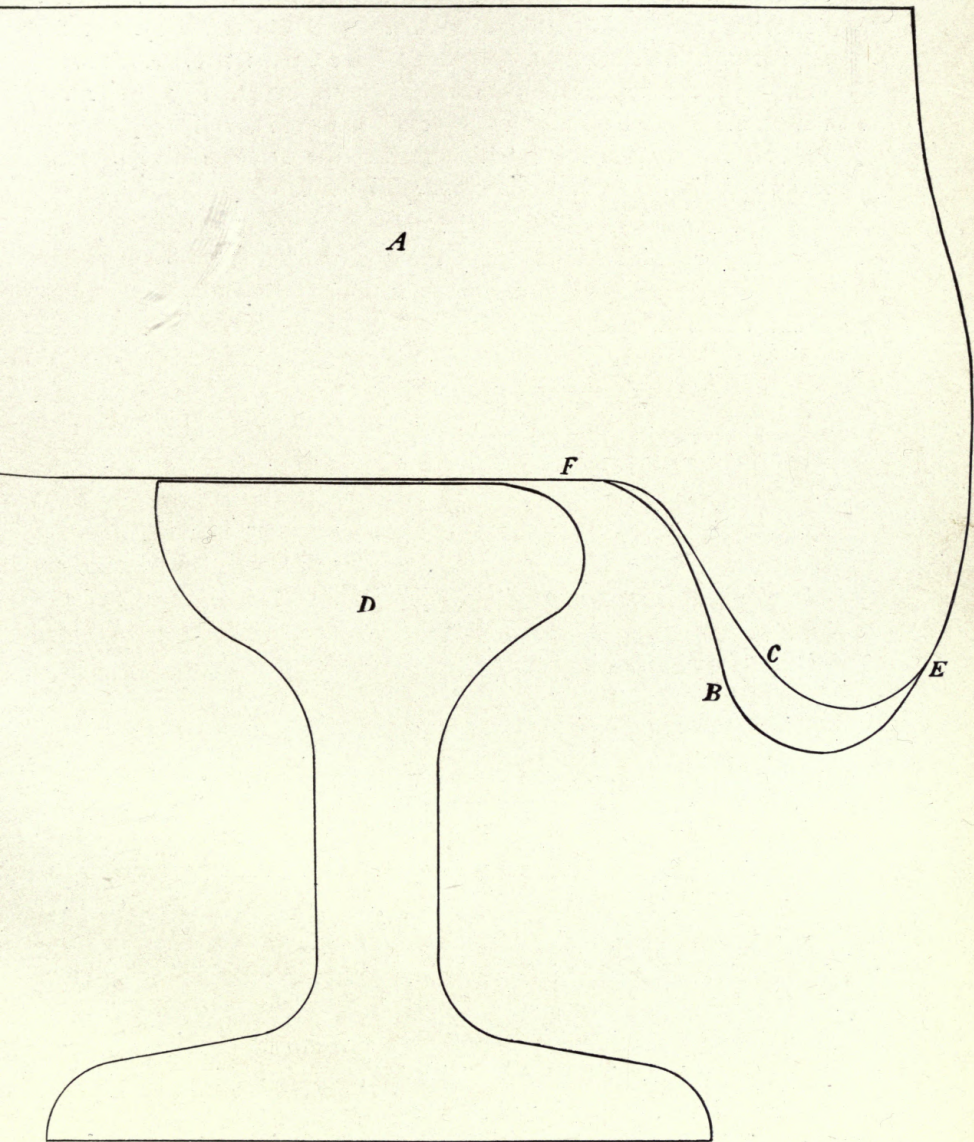

Fig. 44a.

He also claims the Tyson tires to be further defective "in point of soundness and strength," by reason of the flange being situated at the top of the mould in casting the tires, instead of at the bottom of the mould as in the tires furnished by himself, supporting this statement by a test of one of the tires which were cast with the flange uppermost, the iron immediately under the flange of which he found to be less sound than, and 25 per cent. inferior in strength to, iron taken from the same relative position in one of his tires which was cast with the flange down.

In the opinion of the writer, neither of the parties to this controversy was entirely correct in the position taken by him, or free from prejudice in his assertion of it. The necessity of a leading truck was not, with the comparatively slow speeds under which freight trains were then operated, universally admitted, but its advantage and advisability should have been recognized by Mr. Winans, and an effort, which would doubtless have been successful, made by him to apply it in the camel engines, together with the correction of a number of structural defects which were apparent, and were developed, although probably exaggerated, in the controversy. On the other hand, the advantage of high tractive power, due to a sufficiency of weight available for adhesion, ought to have been recognized as of most substantial importance by the advocates of the ten-wheel engine, and, as present practice shows, they were absolutely incorrect in their objection to large fireboxes. It is probable that if this controversy had been amicably settled, the skill and ingenuity of Ross Winans would have resulted in the development by him of the 2-8-0 type, as a compromise between the camel and the ten-wheel engines, and the continuance of his manufacture of locomotives much beyond the period at which he abandoned it.

The only locomotive built by Ross Winans in which a leading truck was applied in connection with more than two pairs of driving-wheels, is believed to have been the "Centipede," which had eight driving-wheels, 43 inches in diameter, and a four-wheeled leading truck, and the writer also believes that this was the first engine of the 4-8-0 type that was ever constructed. The boiler was of the same style, and about the same size, as those of the medium length furnace camels, and the cylinders were 22 inches in diameter, and 22-inch stroke of piston. The engine had independent cut-off valves, and the cab was located on the bumper platform, the throttle-rod passing through the stack. The bearings of



the truck axles extended nearly the entire length between wheels, and there were other peculiar structural details. The "Centipede" was built in 1856; no drawings of the engine have been developed by the writer, who gives the above particulars from his personal recollection. The "Centipede" was purchased by the Baltimore & Ohio Railroad Company, together with the three last long furnace camels built by Ross Winans, in 1863, and after having been fitted with a cab on top of boiler, and changed in some other particulars, was operated for a time on the heavy grades of the Third Division.

## CHAPTER VIII.

## THE LATER LOCOMOTIVE DESIGNS OF THATCHER PERKINS AND THE FIRST MOGUL PASSENGER ENGINE.

The modernization of the motive power which was begun by Henry Tyson, as previously noted, was actively continued by his successor, Thatcher Perkins, who, commencing in 1863, designed and built at Mount Clare, three classes of locomotives, which, while of later date than the period intended to be covered herein, are of interest and are presented, as being the intermediate links between the early motive power which has been described in the preceding chapters and the thoroughly modern equipment of the road at the present time. These engines were of the 4-6-0, 4-4-0 and 0-8-0 types, respectively, and each of the classes was the most advanced of its type, and embodied all the approved features of construction that were known at the time it was developed. All these engines remained in service for many years, and, until they were worn out or displaced by others of later and more perfected designs, they satisfactorily complied with the requirements which they were designed to meet.

Engine No. 117, which is shown in Fig. 45, was placed on the road in the early part of 1863, and was the first of the class known as the "Perkins ten-wheelers," the other engines of practically the same construction being Nos. 9, 13, 14, 18, 19, 29, 35, 36, 136 and 147. This class was designed for, and operated in passenger service on, the heavy grades between Piedmont and Grafton, and during the civil war some of the engines were also used for hauling troop trains over the Eastern Divisions of the road.

The boiler of engine No. 117 was, as shown in Fig. 46, of the extended wagon-top pattern, and was the first in which the combustion chamber was applied on the road. It will be noticed that it was very long and had a hopper in its bottom; this was nicknamed "Horace Greeley's hat," and was always a source of more or less trouble on account of leaks. The shell was of  $\frac{5}{16}$  iron,  $47\frac{1}{4}$  inches in outside diameter of sheet next to smoke-box, and the firebox was  $78\frac{7}{8}$  x 42 inches outside, giving a grate area of about 16.7 square feet. The combustion chamber was, after a comparatively short term of service, removed and an ordinary fire-box flue-sheet and long tubes substituted.

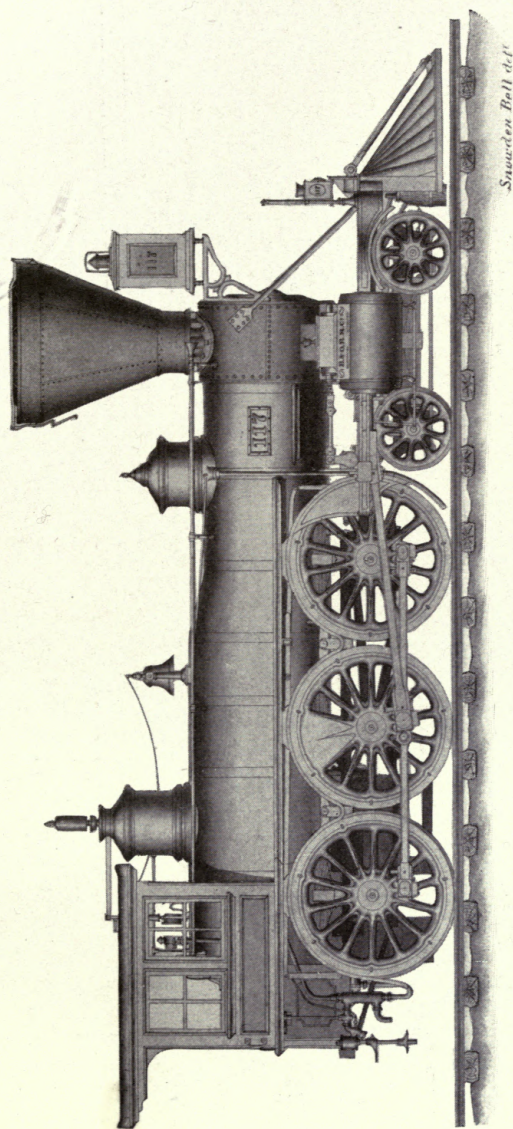

Fig. 45.

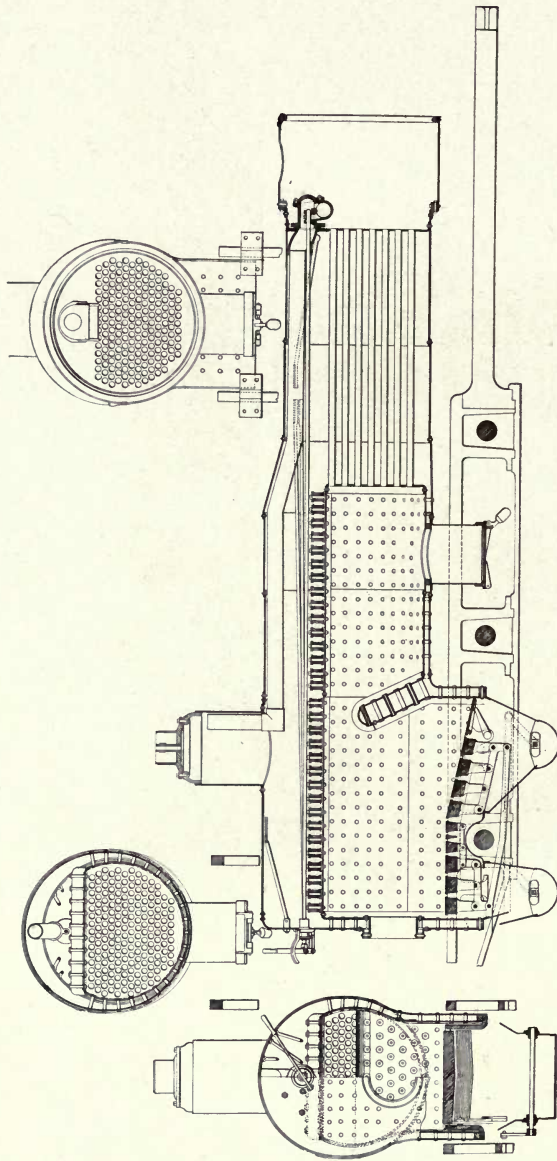

Fig. 46.

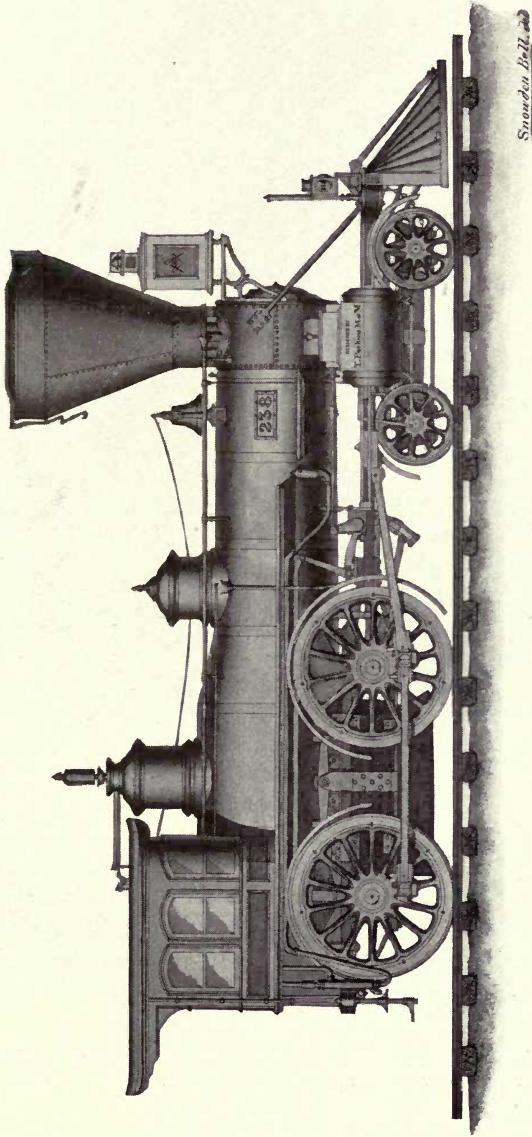

Fig. 47.

The boilers of the other engines of this class had larger fire-boxes, their dimensions being 84 x 34 inches inside, giving a grate area of 19.83 square feet. There were 138 tubes, 2¼ inches outside diameter and 12 feet 4¼ inches long. The tube-heating surface was 1,004.25 square feet; firebox-heating surface, 108.67; total heating surface, 1,112.92 square feet.

The cylinders of the Perkins ten-wheelers were 19 x 26, and the driving wheels of engine No. 117, 64½ inches in diameter. Those of the other engines of this lot were 60 inches in diameter, except Nos. 9, 13, 36 and 136, which were 58 inches. The weight of engine No. 18 appears in the Company's records as 90,700 pounds, of which 22,400 pounds was on the truck, and the weight of the tender was 22,900 pounds. The valve-gear was of the Gooch or "stationary" link type, as in the Tyson ten-wheel engines, and in order to obtain a sufficiently long radius (55 inches) for the links, the front ends of the die-rods were coupled to arms on a supplemental shaft journalled on the frame immediately behind the saddle, from which connecting rods extended back to the lower arms of the main rock shaft. The engines had bar frames of modern type, and cylindrical smoke-boxes set on saddles, or "bed-plates," as they were then called, the cylinders being separate castings.

Five 4-4-0 type engines, Nos. 237, 238, 239, 240 and 241, known as the "Perkins passenger engines," were built by Mr. Perkins, the first of them being placed on the road in January, 1865, and the last in December, 1866. No record has been found in the Motive Power Department of the weight and dimensions of these engines, but the writer, who made a number of the drawings for them, remembers that their cylinders were 17 x 24 inches; their driving wheels 66 inches; and their boilers 46⅝ inches diameter at ring next to smoke-box. It will be seen from Fig. 47 that they were of the same general design as the Mason engines of 1857 (Fig. 19), from which they did not differ except as to their boilers being of the "wagon-top" form, and in having larger cylinders and driving wheels; an increase of six inches in rigid wheel base; and injectors instead of cross-head pumps. One of them, which is believed to be No. 240, was fitted with Gooch links, and the remainder with ordinary shifting links, as shown in Fig. 47.

Another class of engines was designed by Thatcher Perkins for heavy freight service, these being of the 0-8-0 type, and known as the "Perkins eight-wheel connected engines" and the "green-

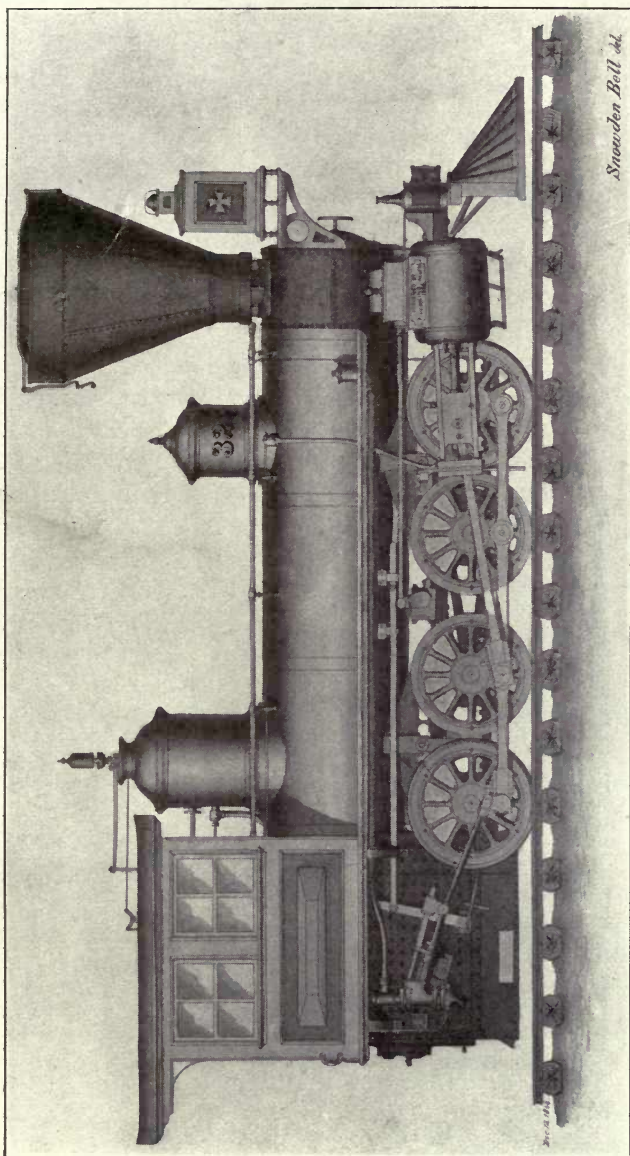

Fig. 48.

backs." The first of these engines, which is shown in Fig. 48, was originally numbered 83 and changed to 32, and was built at Mount Clare and placed on the road in February, 1865. Another of the same class, No. 242, was subsequently built at Mount Clare; two more, Nos. 263 and 264, by Reaney, Son & Archbold, of Chester, Pa., in October and November, 1865, and twenty more, Nos. 243 to 263 inclusive, by the Grant Locomotive Works, of Paterson, N. J., in August, September, October and November, 1865. One complete boiler and practically all the castings and forgings for the Chester engines were furnished by the Company, who also furnished all the tender wheels for the twenty Paterson engines. The latter engines were contracted for at the price of \$20,000 each, being required for early delivery, which, at the close of the civil war, was difficult to obtain, and prices then being high.

The Perkins eight-wheel engines were similar to the "camels," which they were intended to supersede, only in the particulars of having overhung fireboxes, of the full width over frames, and 43-inch driving wheels. Their boilers were larger, being of the straight type, of  $\frac{3}{8}$  iron, 48 and  $48\frac{3}{4}$  inches diameter at alternate rings, and their cylinders were originally bored out to  $19\frac{1}{2}$  inches, but were designed to be rebored to 20 inches, being  $1\frac{1}{4}$  inches thick. Their frames, which were of the bar type, were very substantial, weighing about one ton apiece, and having top rails finished to  $3\frac{3}{4} \times 6$  inches. The link motion was of the Gooch type, and a 55-inch radius was obtained for the links by the same means as in the ten-wheel engines. The links were cast iron, of box form, and weighed 434 pounds each. The draw-bar extended through the ashpan, and its front end was coupled to a pin fitted in cross braces bolted to the bottom frame rails. This arrangement, by which the boiler was entirely relieved from strains of draft and buffing, has, within a few years past, been brought out as a new and original design.

The principal particulars of these engines were as follows:

Weight, 65,000 pounds (empty); cylinders,  $19\frac{1}{2} \times 22$  inches. Boiler, larger diameter,  $48\frac{3}{4}$  inches; thickness,  $\frac{3}{8}$  inch; pressure, 100 to 110 pounds; 115 flues, No. 12 W. G.  $2\frac{1}{2}$  inches outside diameter and 15 feet long; inside firebox, length, 66 inches; width, 42 inches; depth, 57 inches; grate area, 19.25 square feet; flue-sheet (copper),  $\frac{5}{8}$  inch; back sheet (copper),  $\frac{3}{8}$  inch; side sheets (copper for  $36\frac{1}{2}$  inches from bottom),  $\frac{3}{8}$  inch; exhaust nozzle (single),  $4\frac{1}{2}$  inches. Weight of tender, 23,000 pounds; water capacity, 2,140 gallons.



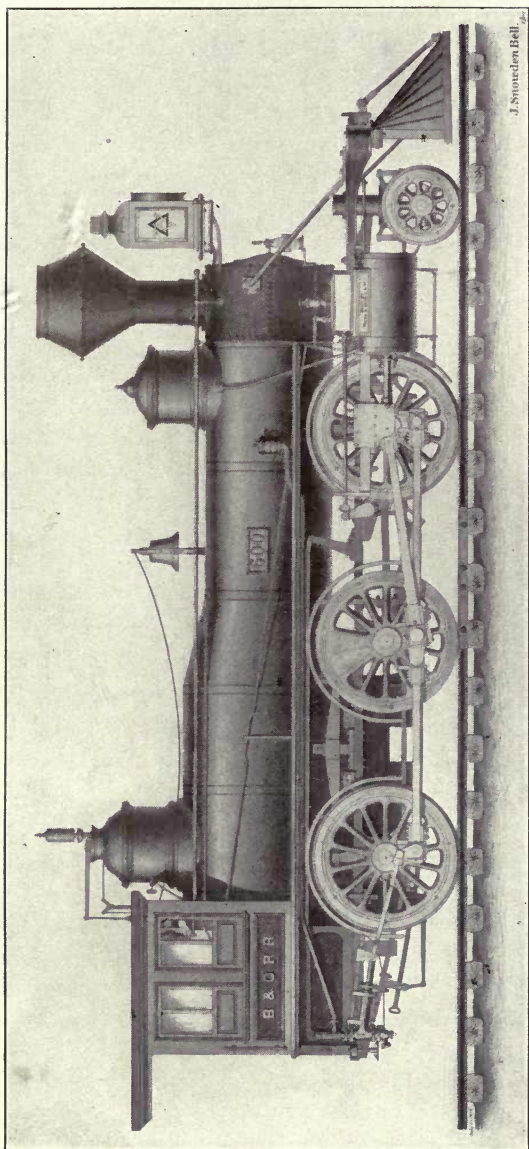

Fig. 49. **MOGUL**

Engine No. 600, Fig. 49, which was the first passenger service engine of the "Mogul" or 2-6-0 type that was placed on the Baltimore & Ohio Railroad, was designed and built by John C. Davis, Master of Machinery, at Mount Clare, in 1875, and was intended for hauling mail and express trains over what was then the Third Division, extending from Keyser to Grafton,  $78\frac{3}{4}$  miles, and including the seventeen-mile grade of 116 feet to the mile. This engine had larger grate area than the Perkins ten-wheel engines, 137 square feet excess of heating surface, and about 8,000 pounds more weight on the driving wheels, but apparently did not give as good a performance in this service, as it was not long continued in it, and was not duplicated for passenger service, although others of the same design were subsequently built for fast freight. Passenger trains are now taken over this Division by 4-6-2 engines, having 24 x 32-inch cylinders and weighing 263,800 pounds with 166,200 pounds on driving wheels, helping engines being required on the heavy grades with trains of over seven cars.

The weight and general dimensions of engine No. 600 were as follows: Weight in working order, 90,400 pounds; weight on drivers, 76,550 pounds; cylinders, 19 x 26 inches; driving wheels, 60 inches diameter; boiler diameter outside, smallest ring, 50 inches; thickness (iron),  $\frac{3}{8}$  inch; number of tubes, 165; outside diameter of tubes,  $2\frac{1}{4}$  inches; length of tubes, 11 feet  $10\frac{1}{2}$  inches; firebox length (inside), 8 feet  $3\frac{7}{8}$  inches; width (inside),  $34\frac{5}{8}$  inches; grate area, 23.7 square feet; heating surface, firebox, 122 square feet; heating surface (tubes), 1,150 square feet; total heating surface, 1,272 square feet; weight of tender (empty), 51,000 pounds; coal capacity, 120 bushels; water capacity, 3,000 gallons.

## CHAPTER VIII.

## EXAMPLES OF THE PRESENT MOTIVE POWER.

The general characteristics of all of the early locomotives of the Baltimore & Ohio Railroad that have been described in the preceding chapters, except those of the 0-4-0 and 4-2-0 types, have been reproduced in the present equipment, with such improvements in structural design and details, and increase of dimensions and operative capacity, as place it in the highest class of modern motive power. A complete description of the present locomotive equipment would be much beyond the intended scope and limits of the writer's work, but the following examples are presented as generally illustrative of its character, and may be of interest as indicating the extent of the advance which has been made, on this and other American railroads, over prior practice.



Fig. 50.

A heavy and powerful 0-6-0 type engine for switching service, No. 1184 (Company's class D-23), is shown in Fig. 50. The engines of this class, which were built by the Baldwin Locomotive Works, are designed for burning anthracite culm or other low-grade fuel, and weigh 161,080 pounds. Their cylinders are 19 x 28 inches; driving-wheels, 52 inches; wheel-base, 11 feet; boiler, 70 inches diameter, of  $\frac{3}{4}$ -inch steel; firebox, 110 inches long and 96 inches wide; 220 tubes,  $2\frac{1}{4}$  inches diameter and 11 feet 6 inches long; heating surface (firebox), 167 square feet; heating surface (tubes), 1,487.6 square feet; total heating surface, 1,654.6 square feet; grate area, 73.33 square feet; working pressure, 180 pounds; tender, tank capacity, 4,000 gallons water; coal, 6 tons.

Engine No. 1430 (Fig. 51), which is one of the latest design of the Atlantic type, was built by the Baldwin Locomotive Works for passenger service, and is of Company's class A-3. The weight and general dimensions of this class are as follows: Weight on driving-wheels, 116,000 pounds; on leading truck, 39,000 pounds; on trailing truck, 35,000 pounds; total weight of engine, 190,000 pounds; cylinders, 22 x 26 inches; driving-wheels, 80 inches; total

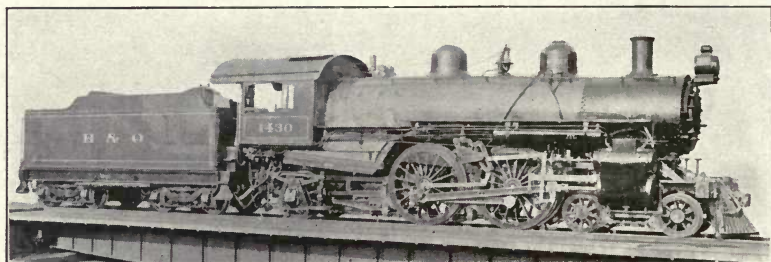

Fig. 51. ATLANTIC

engine wheel base, 30 feet 9½ inches; rigid wheel-base, 7 feet 5 inches; boiler, 67 inches diameter, of 11/16-inch steel; firebox, 109 inches long and 72 inches wide; 247 tubes, 2¼ inches diameter and 15 feet 1 inch long; heating surface (firebox), 168 square feet; heating surface (tubes), 2,182 square feet; total heating surface, 2,350



Fig. 52. PACIFIC

square feet; grate area, 55.5 square feet; working pressure, 205 pounds; tender, tank capacity, 7,000 gallons water; coal, 15 tons.

Pacific type engine No. 2140 (Fig. 52) is one of the Company's class P-1, and was built by the Baldwin Locomotive Works, for heavy and fast passenger train service. Weight on driving-wheels, 166,200 pounds; on leading truck, 52,400 pounds; on trailing truck, 45,200 pounds; total weight of engine, 263,800 pounds;

cylinders, 24 x 32 inches; driving-wheels, 74 inches; boiler, 78 inches diameter, of  $11/16$ ,  $23/32$  and  $3/4$  steel; firebox, 120 inches long and 84 inches wide; 389 tubes,  $2\frac{1}{4}$  inches diameter and 21 feet long; heating surface (firebox), 228 square feet; heating surface (tubes), 4,789 square feet; total heating surface, 5,017 square feet; grate area, 70 square feet; working pressure, 205 pounds; tender, tank capacity, 9,500 gallons water; coal, 16 tons.



Fig. 53. **CONSOLIDATION**

Consolidation type engine No. 2718 (Fig. 53) is one of the Company's class E27b, and was built by the American Locomotive Company for freight service. Weight on driving-wheels, 194,000 pounds; on truck wheels, 23,000 pounds; total weight of engine, 217,000 pounds; cylinders, 22 x 30 inches; driving-wheels, 60 inches; boiler,  $74\frac{1}{2}$  inches diameter, of  $3/4$ -inch steel; firebox,  $107\frac{5}{8}$  inches long and  $75\frac{3}{8}$  inches wide; 280 tubes,  $2\frac{1}{4}$  inches diameter and 15 feet 10 inches long; heating surface (firebox), 185 square feet; heating surface (tubes), 2,607 square feet; total heating surface, 2,792 square feet; grate area, 55.24 square feet; working pressure, 205 pounds; tender, tank capacity, 7,000 gallons; coal, 15 tons.

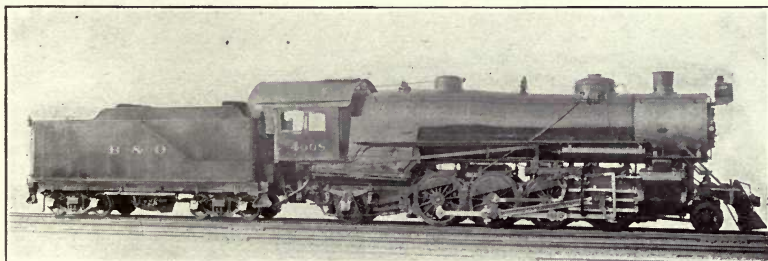

Fig. 54. **MIKADO**

Mikado type engine No. 4008 (Fig. 54) is one of the Company's class Q-1, and was built by the Baldwin Locomotive Works for freight service. Weight on driving-wheels, 219,000 pounds; on leading truck, 19,500 pounds; on trailing truck, 36,100 pounds; total weight of engine, 274,600 pounds; cylinders, 24 x 32 inches; driving-wheels, 64 inches. The particulars of the boiler and tender are the same as those of the Pacific type engine No. 2140 before described.

Mallet engine No. 2401 (Fig. 55) is one of the Company's class O-1, and was built by the American Locomotive Company for freight and helper service. Weight of engine, 454,000 pounds; cylinders, 26 and 41 x 32 inches; driving-wheels, 56 inches; boiler, 90 inches diameter, of 15/16-inch steel; firebox, 126 inches long and 114 inches wide; 277 tubes, 2¼ inches diameter and 24 feet long; 38 superheating tubes, 5½ inches diameter and 24 feet long; heating surface (firebox), 353 square feet; heating surface (tubes), 3,892.38 square feet; total heating surface, 4,245.38 square feet; grate area, 100 square feet; working pressure, 210 pounds; tender, tank capacity, 9,000 gallons water; coal, 14 tons. These engines are fitted with superheaters, of the Schmidt fire tube type.

Among the characteristic differences between the early and the present motive power, in addition to the great increase of weight and dimensions in the latter, may be noted the adoption of the wide firebox, piston valves, and Walschaert valve gear, and the substitution of a straight open stack, with spark arresting appliances in the smoke-box, for the spark arresting stacks formerly used.

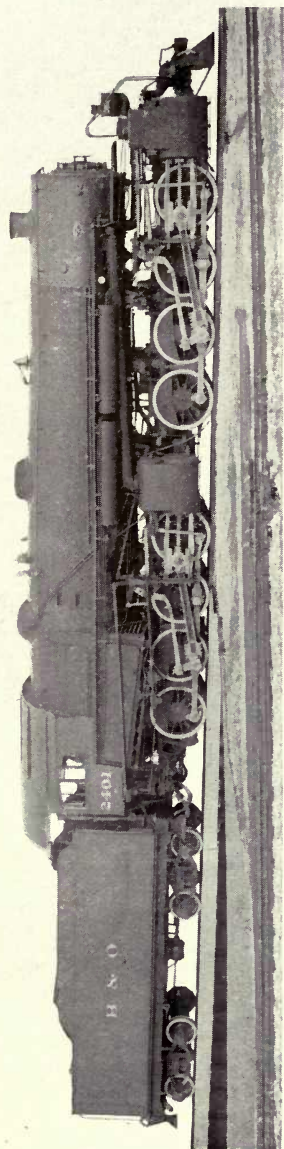

Fig. 55. MALLET TYPE

## CHAPTER IX.

## EARLY MOTIVE POWER OFFICERS.

PHINEAS DAVIS, the designer of the first locomotive of the Baltimore & Ohio Railroad that was adapted for practical and successful railroad service, while in fact the first actual Chief of the Motive Power Department, does not appear to have acted as such under an official designation, but, in view of the character and importance of his duties and achievements, he may be properly regarded, not only as an officer of that Department, but also, as a mechanic and a man, worthy of a more extended biographical notice than can be derived from the very limited data as to his life and work that is obtainable. The following particulars of his career are taken, by permission, from a biographical notice which appears in Prof. Geo. R. Prowell's *History of York County, Pennsylvania*.

Phineas Davis was born in Grafton, New Hampshire, in 1795. He became an orphan at the age of 13 years, and having to depend upon his own exertions for a livelihood, he left his home and sought employment in Lowell, Providence and other Eastern cities. In 1809 he arrived in York, Pennsylvania, a bare-foot boy, and obtained a situation with Jonathan Jessop, who was then the principal watchmaker of the town. He was apt to learn, and attentive to duty, and soon showed his ability by making a gold watch, the product of his own skill and application, the mechanism of which involved new ideas of his own and was the subject of much favorable comment.

During his leisure hours in Mr. Jessop's store, Phineas Davis had been a diligent student of natural philosophy and chemistry, and became much interested in the investigation of steam and its application as a motive power. He became associated as a partner with Morris J. Gardner, in the York foundry and machine shop, on the west side of the Codorus, in York, Pa., and while carrying on business there, took up the study of the locomotive engine, which was then in its infancy in England, and undeveloped in the United States. Stimulated by the offer of the Baltimore & Ohio Railroad Company, which was made January 4, 1831, of the sum of \$4,000 for a locomotive engine of American manufacture, he designed and built at the York foundry the locomotive "York," which, as before noted, successfully performed the conditions of



the test made on June 1, 1832, and was purchased by the Company. Several other locomotives of the same type, but of improved construction and larger dimensions, were built by Davis & Gardner, in 1832, and soon afterwards Mr. Davis took charge of the Company's shops at Mount Clare Station, Baltimore, and continued the manufacture of locomotives and cars at those shops, until his death, at the early age of forty years, on September 27, 1835, as the result of the derailment of one of his engines on which he was riding.

The Board of Directors of the Company fittingly expressed its high appreciation of the character and service of Mr. Davis in the following minute, which appears in the Ninth Annual Report, 1835:

"Phineas Davis was the first who constructed an engine, capable of being used on the road, in which anthracite fuel was successfully employed. With untiring patience he bore disappointment after disappointment; and the eminent and splendid results, which ultimately rewarded his efforts, are ample testimonials of his genius, and will identify his name, most honorably, with that great system of internal improvement, which is yet to work so many and such important changes in the relations of society. Of a quick and clear perception, on matters relating to his profession, he possessed a calm, discriminating judgment. The warmth and energy of inventive talent were tempered by a prudent foresight and great practical skill. He seldom, therefore, took a step, which was not a secure one; and the success of his suggestions, when put into practice, gave them, from the first, almost the same weight as if they had been the dicta of experience. His private worth and unassuming manners were not less remarkable than his rare abilities. The Board deeply regrets his loss and hold his memory in sincere and respectful consideration."

The remains of Phineas Davis were buried in the Friends Meeting House ground, at York, Pa., and at the present writing his grave is unmarked. It is, however, probable that the Company will, at an early day, erect over it a suitable monument.

The Fifth Annual Report of the road, 1831, contains the report of *J. Knight*, Chief Engineer, in which he refers to his assistants, *J. Elgar* and *Ross Winans*, each of whom was entitled "Assistant Engineer of Machinery," and the Sixth Annual Report, 1832, mentions the appointment of *George Gillingham*, as "Superintendent of Machinery," on September 29, 1832. Mr. Gillingham held this

position until after the death of Phineas Davis, in 1835, when he and Ross Winans took the Company's shops at Mount Clare, and there continued the manufacture of locomotives and cars under an arrangement with the Company, which has been referred to in a preceding chapter. The reports of *James Murray*, "Engineer of

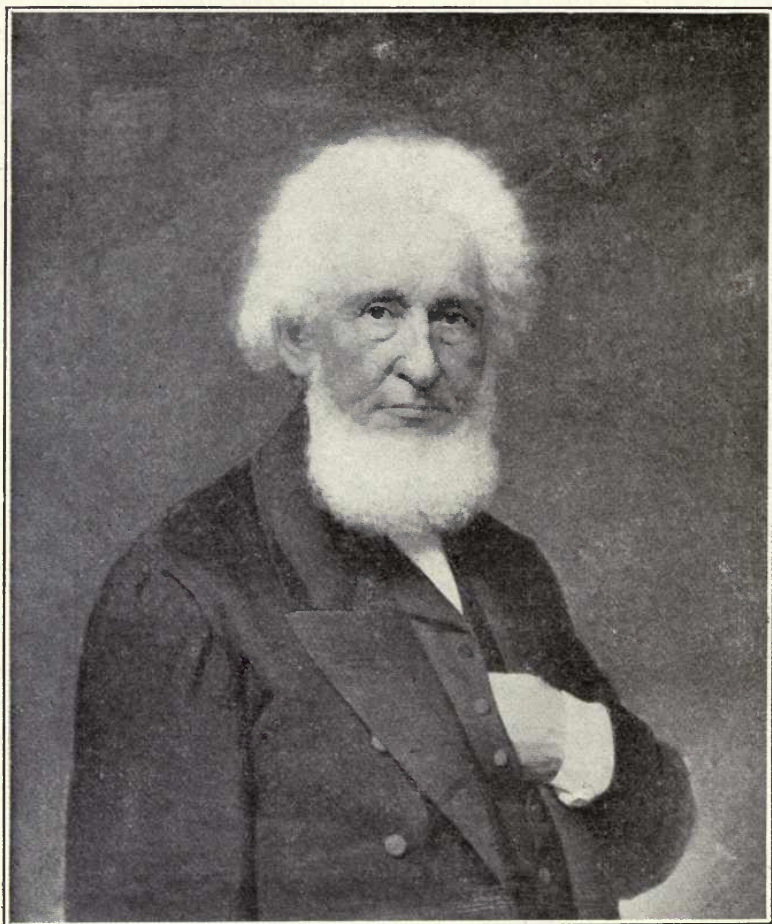

ROSS WINANS.

Machinery and Repairs," appear in the 17th, 18th, and 20th Annual Reports, 1843 to 1846. *Thatcher Perkins* was "Master of Machinery" as early as 1847, and resigned in 1851, to go into business as a manufacturer of locomotives. He was succeeded by *Samuel J. Hayes*, who held the same position from 1851 to 1856.

*Henry Tyson* was appointed Master of Machinery, in June, 1856, and was succeeded by *Thatcher Perkins*, who returned to the Company's service December 1, 1859, and remained in charge of the Machinery Department until 1865.

ROSS WINANS, who has been appropriately characterized as "one of the strongly marked men of his generation," and as having "peculiar traits which would have made him a conspicuous character, no matter what calling he had chosen," was born at Vernon, N. J., October 16, 1796. He began life as a farmer, and at an early age showed great inventive genius. One of his early inventions was an improvement in fulling cloth by steam, for which his first patent was granted June 26, 1821. This was followed by many others, prominent among which were outside bearings for railroad axles, roller journal bearing, the eight-wheeled passenger car, the "coal hopper" car, which was the first freight car in which the load capacity exceeded the dead weight, and numerous improvements relating to locomotives for freight service, including the variable exhaust. In his later years, he devoted considerable attention to, and made elaborate and costly experiments in, the construction of steam vessels, including the building and testing of several, which from the novel and peculiar form of the hulls which he invented and applied in them, were known as "spindle-shaped ships" or "cigar" steamers. While this system of construction did not prove to be of practical value and did not go into use beyond his own experiments, it was a striking evidence of his originality and boldness of conception and execution in the mechanic arts.

The mechanical skill and executive ability of Mr. Winans were first actively exercised in the service of the Baltimore & Ohio Railroad, with which he became connected before the commencement of its construction on July 4, 1828, one of his first duties being to act as a member of a committee which presented to Congress a memorial, dated January 28, 1828, relative to an appropriation to aid the work.

Soon thereafter he was sent to England by the Company, to study the English railroad systems, and spent a year there in observations which proved of great value to it. The time of this visit appears to be indicated in a statement in the specification of his patent of July 20, 1831, for an "improvement in the construction of the axles and bearings of railway and other carriages" (outside journal bearings), in which he says:

"This improvement in the axles and journals of railway car-

riages was devised and carried into operation on my experimental railway and exhibited to various persons in the early part of the year 1827; and it was put into practical operation, under my direction, on the Baltimore & Ohio and on the Liverpool & Manchester railroads in the early part of 1829."

In the Fifth Annual Report of the Baltimore & Ohio Railroad, 1831, Mr. Winans is mentioned as Assistant Engineer of Machinery, and he doubtless had held this position from an earlier date, having reported to the President, as an engineer, on the experimental locomotive of Peter Cooper, August 28, 1830. After the death of Phineas Davis, who had been in charge of the Machinery Department of the road, on September 27, 1835, Mr. Winans entered into partnership with George Gillingham, under the firm name of Gillingham & Winans, who took the Company's shops at Mount Clare, Baltimore, and there continued the manufacture and repair of locomotive engines and cars which had been previously conducted by Mr. Davis for the Company, including the so-called "crab" engine which had been designed and patented by Mr. Winans.

At a subsequent date, which the writer has not been able to ascertain definitely, but which is believed to have been in the year 1843, Mr. Winans erected what was then considered to be the largest locomotive building establishment in the country, on West Pratt Street, Baltimore, opposite the Baltimore & Ohio Railroad Company's Mount Clare shops, and commenced the manufacture of locomotives, which he actively continued until 1860. The Eighteenth Annual Report of the Baltimore & Ohio Railroad Co., 1844, states that "as early as that period (March, 1842) Ross Winans, an ingenious mechanic of Baltimore, had not only contrived a far more important improvement in the locomotive, but had actually constructed an engine weighing twenty tons, running on eight wheels, all of which were drivers," etc. The first engine that he built for the Baltimore & Ohio Railroad, the "Hercules," which was of this type and was placed on the road in October, 1844, was probably the first that he constructed in his own shops, and the first "camel" engine—a class that was distinctively and thoroughly original with him—was built in 1848, for the same road. He thereafter built a considerable number of "camel" engines, and was so ardent and uncompromising an advocate of that design that, with but very few exceptions, he would build no others. Notwithstanding the great tractive power of these engines, and the fact that they had rendered more efficient service

in freight traffic than any others of their time, they were defective in a number of particulars, to such an extent that, as the result of an extended and bitter controversy which arose between Mr. Winans and the Machinery Department of the Baltimore & Ohio Railroad, in 1857, as to the relative merits of the camel and ten-wheel engines, which has been referred to in a preceding chapter, their manufacture was discontinued, and no locomotives of any kind were built by Mr. Winans after 1860.

At the outbreak of the civil war, in April, 1861, a "steam gun" was exhibited in front of the City Hall, in Baltimore, which was alleged to have been made at Mr. Winans' shops for the purpose of being sent to the Confederacy or used in opposing the pas-

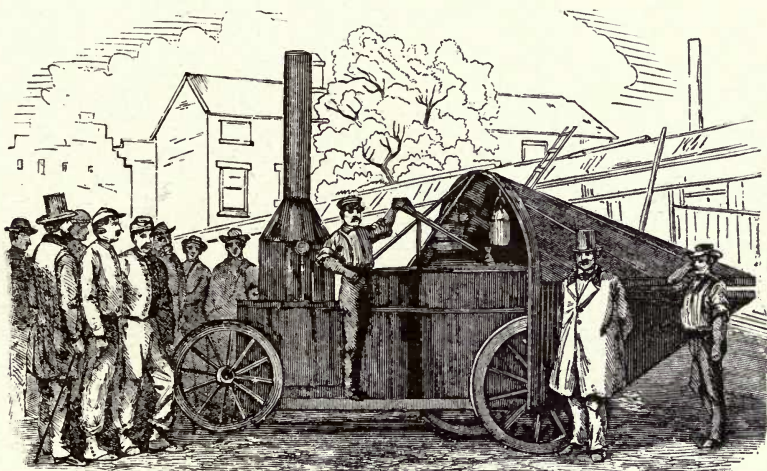

THE WINANS "STEAM GUN."

sage of Federal troops through the city. The external appearance of this machine is shown in the above reduced reproduction of a wood cut of the period, which was prepared from a photograph. No definite particulars of its mechanism have been developed by the writer, and it is doubtful whether any description or drawings of it are in existence. So far as can be understood from a recently published statement of a resident of Baltimore, who witnessed a test of the gun and photographed it, the balls were fed into a species of hopper and projected by centrifugal force from a receiver therein, which was rotated at very high speed. This observer describes the test as having been apparently a successful

one, but the gun was pronounced to be impracticable by the United States military experts, who subsequently examined it, and no record has been found to the effect that it was ever put in service or even experimented with to any extent that was made public.

Mr. Winans, being, like many other prominent citizens of Maryland, an ardent Southern sympathizer and opposed to the coercion of the Southern States, naturally fell under the displeasure of the Federal military authorities, and having been, in May, 1861, elected a member of the Maryland Legislature for a special session, he was, with other members, arrested September 12, 1861, while on his way to Frederick City, where the legislature met, but was soon afterwards released. Thereafter, he took but little part in public affairs, and, having acquired a large fortune, spent the remainder of his life in comparative retirement, but in local matters, especially in projects for improving the city of Baltimore, he exhibited the liveliest interest, and was, throughout his life, one of its worthiest and most esteemed citizens. He died April 11, 1877, in the 81st year of his age.

Mr. Winans wrote a number of pamphlets, and several books on the subject of theology, which, however, were not in accordance with orthodox views. His warm philanthropy was constantly exerted in devising measures for the improvement of the conditions of the poor; he was happy in his domestic relations, fond of home; plain and unostentatious in his mode of life; and made no display of his wealth. His name will always occupy a prominent and honorable place in the annals of Baltimore, and in the history of the locomotive engineering of the United States.

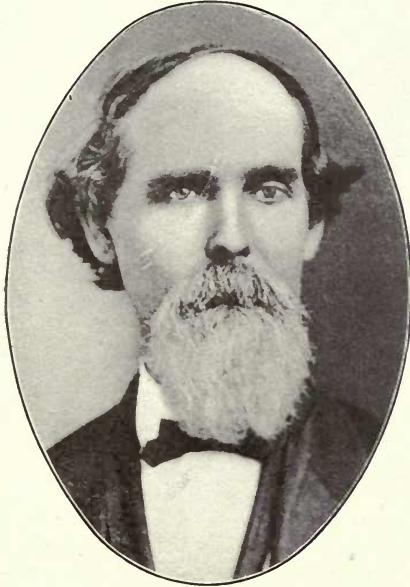

SAMUEL J. HAYES.

SAMUEL J. HAYES was born near Powhattan Factory, four miles from Baltimore, Md., October 9, 1816. He was left fatherless when four years of age, and was compelled, two years later, to go to work in a cotton mill, where he continued to work for eleven years. At the age of seventeen, he became an apprentice in the Company's Mount Clare shops, then operated by Gillingham & Winans, and in 1837, when the Company took control of these shops, he entered its service. Three months after completing his apprenticeship, he was made a

gang foreman, and at the age of twenty-three was appointed shop foreman, having also charge of the engines running on the adjacent portion of the line. He was afterward made Master Mechanic, and held that position until 1851, when he was appointed Master of Machinery. The Twenty-fifth Annual Report, 1851, in mentioning his appointment, states that he was "long a foreman in the Company's service, who has commended himself to confidence as well since his promotion as before."

The able administration of Mr. Hayes was characterized by his design and construction, in 1853, of the "Hayes ten-wheelers," which have been described in the chapter relating to the 4-6-0 engines. These embodied much structural improvement over the former motive power, and gave entirely satisfactory results in service, as was recognized by the construction of a considerable number of the same type, twenty years afterwards.

Mr. Hayes continued in the service of the Baltimore & Ohio Railroad until he accepted a similar position with the Illinois Central Railroad, whose service he entered August 26, 1856, and con-

tinued actively in charge of the Machinery Department of that company nearly to the date of his death, September 21, 1882.

The above particulars are mainly derived from an obituary notice by Mr. E. T. Jeffrey, which appears in the Sixteenth Annual Report of the American Railway Master Mechanics Association, 1883, and in which the following statement is made regarding him:

“He was amiable in personal character, beloved and respected by his subordinates, who served him zealously and still look back with pleasure to their connection with him, grateful alike for his kindly personal interest and the thorough training his strict intelligent discipline afforded them.

“His remarkable vigor was undiminished to the last. He gave his undivided attention to the affairs of his department until within two months of his death.”





HENRY TYSON.

HENRY TYSON, who next succeeded Mr. Hayes as Master of Machinery, was born in Baltimore, Md., in 1820, and was first engaged in milling, on Commerce Street, in that city, with A. S. Dungan, as a member of the firm of Tyson & Dungan. He was appointed Master of Machinery of the Baltimore & Ohio Railroad in June, 1856, and held that position until the latter part of 1859. He was then elected President of the Baltimore City

Passenger Railway Co., and held this position for thirteen years, after which he was elected Fourth Vice-President of the New York & Erie Railroad, in charge of the Machinery Department. The difficulties with which this road was then contending were so great that Mr. Watson, the President, and Mr. Tyson, soon retired from office, the term of Mr. Tyson being only about twelve months.

In 1870 Mr. Tyson prepared a plan for the improvement of Jones' Falls, in Baltimore, for which he was awarded by the Committee of Arbitration the sum of \$5,000, and in the Fall of 1875, Judge Bond, of the U. S. Court, appointed him Receiver of the Chesapeake & Ohio Railroad. His services in this position were so effective and valuable that the Court awarded him the sum of \$10,000, as his compensation for a comparatively brief term. He was Shipping Commissioner of Baltimore, at the time of his death, September 8th, 1877, at the early age of 57 years.

The record of the progressive improvements that were made in the motive power of the Baltimore & Ohio Railroad leaves no room for question that what may properly be termed its *modernization* was begun by Mr. Tyson, who was a man of broad mind, and advanced views, and earnest and energetic in his efforts to bring his department up to the most advanced standard of practice at that time. One of his first actions in this direction was to intro-

duce the Mason passenger engines, which then combined all the latest and most practical features of structural design, and which were far in advance of any of the earlier motive power, and this was followed by the construction, under his direction, of the "Tyson ten-wheelers," which, even if not fully satisfactory in operation by reason of insufficient weight on their trucks, were susceptible of correction of this defect, and were otherwise so well designed as to avoid the objections, both structural and operative, that were found in the "camel" engines, and to practically bring about the cessation of the manufacture of the latter engines. The result of the controversy between Mr. Tyson and Mr. Winans, which has been referred to at some length in the chapter on the 4-6-0 engines, if not a wholly decisive one, certainly affirmed the correctness of Mr. Tyson's strongly asserted view as to the desirability and advantage of the leading truck, and this has been fully confirmed in the practice of the present day.



THATCHER PERKINS.

THATCHER PERKINS, who succeeded Henry Tyson, commenced his second term as Master of Machinery, December 1, 1859, having previously held that office from June 1, 1847, until February 12, 1851. His mechanical skill and abilities were of a high order, and it is to be regretted that the information as to his life and work, which has been developed by a careful enquiry, is so limited that only a brief and imperfect record can be here presented.

Born in the State of Maine, about 1810, he was left an orphan at an early age, and through his natural abilities, energy, and industry,

attained prominence as a mechanic, while yet a comparatively young man. No record of his life has been found prior to his appointment as Master of Machinery in 1847. He occupied this position until 1851, when he resigned to go into the manufacture of locomotives, as a member of the firm of Smith & Perkins, at the Virginia Locomotive Works, Alexandria, Va. His retirement from the Machinery Department is noted in the Twenty-fifth Annual Report, 1851, with the statement that he "for several years conducted it with much ability." Smith & Perkins built two locomotives for the Baltimore & Ohio Railroad, two for the Allegheny Portage, Pa., fifteen for the Pennsylvania Railroad, and others for Southern roads, but while their work was good, their business was not a profitable one, and they discontinued it in 1858.

Mr. Perkins returned to the service of the Baltimore & Ohio Railroad, as Master of Machinery, December 1, 1859, and held that position until May 10, 1865, when he resigned, having accepted the position of Engineer and Superintendent of the Pittsburgh Locomo-

tive and Car Works, the erection of the plant of which was commenced in that year under his supervision. He continued in charge of this establishment until 1869, when he resigned to take charge of the Machinery Department of the Louisville & Nashville Railroad, in which position he remained until about 1879. He died in Baltimore in 1882.

Mr. Perkins' administrations of the Machinery Department were characterized by many improvements, both in detail and general design, which he made in the motive power, these including improved features introduced in the rebuilding of the camel and other old engines, and the ten-wheel and eight-wheel-connected engines which have been previously described. His designs were always thoroughly practical, and when he considered them desirable, he adopted such details as he found to have been approved in the practice of others. The experience of the writer while serving under him was to the effect that among other sound and useful applications of his mechanical skill and ability, he realized and acted upon the great importance of providing strong and substantial locomotive frames, and any errors which he made as to strength of materials were always on the side of safety. He early applied, and it is believed originally designed, the so-called solid ended side rod, and substituted cast for wrought iron in rockers, links, and other parts, with a reduction in cost, without impairment of efficiency. He is also to be credited with, or be held responsible for, accordingly as the reader may consider most fitting, the introduction of the extended smoke-box on the Baltimore & Ohio Railroad, having fitted one of his ten-wheel engines with it as early as 1864, long before the outbreak of the epidemic of its application which spread over the country in the early eighties, and which the railroads have not even yet entirely recovered from. In all other respects, however, the correctness of his judgment and the value of the results which he accomplished do not appear to have been doubted or questioned.

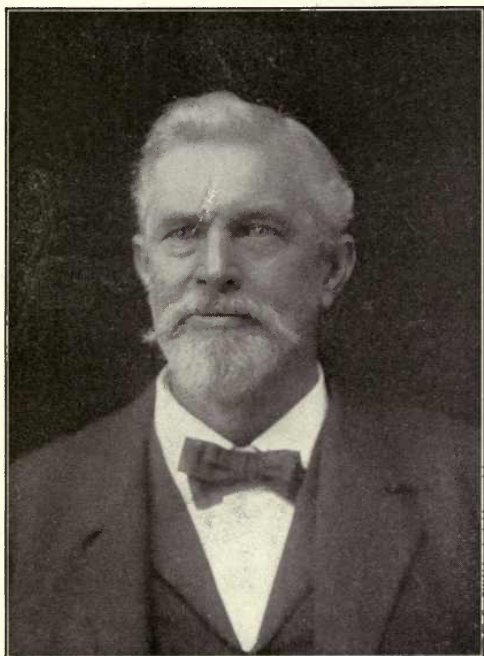

WILLIAM H. HARRISON

WILLIAM H. HARRISON was born in Baltimore, Md., July 10, 1832. At the age of seventeen he entered the shops of the Baltimore & Susquehanna Railroad, now the Northern Central Railway, at Bolton Depot, Baltimore, as a machinist apprentice and remained in the service of that company until 1853. In April of that year he began work for the Baltimore & Ohio Railroad Company, as a journeyman machinist, at Fetterman, Va., and was promoted to the position of General Foreman of the Fetterman

shops in 1856. On September 1, 1858, he was appointed Master Mechanic at Wheeling, Va., and in July, 1863, was transferred to the same position at Mount Clare shops, Baltimore. Owing to failure of his health, he was sent back to Wheeling, October 1, 1864, as Master Mechanic, which position he occupied until August 1, 1872, when he was appointed Master of Machinery of the Pittsburgh & Connellsville Railroad, which had then become a part of the Baltimore & Ohio System. In July, 1873, he was made Assistant Master of Machinery of the Baltimore & Ohio Railroad, under John C. Davis, Master of Machinery, and on December 15, 1880, was transferred, as Master of Machinery, to the lines West of the Ohio River and located at Newark, Ohio. On December 15, 1885, he was made General Superintendent of Motive Power of the entire System, the title of Master of Machinery having been abolished, with headquarters at Baltimore. In January, 1887, the jurisdiction of the Machinery

Department was divided into two Systems, East and West of the Ohio River, and he took charge of that West of the Ohio River, as Superintendent of Motive Power. He held this position until June 1, 1899, when he retired from active service, after a period of continuous service with the Baltimore & Ohio Railroad of over forty-five years. He was an active Mason, and a member of the American Railway Master Mechanics Association from 1885 to the time of his death. He died at Newark, Ohio, September 9, 1899, and was buried in Baltimore, September 12, 1899.

It was the privilege and pleasure of the writer to have served under Mr. Harrison, as draughtsman at Mount Clare shops, during his term of office as Master Mechanic in 1863 and 1864, and the acquaintance then formed with him ripened into friendship which endured throughout the remainder of his life, and is one of the writer's most gratifying reminiscences. Then and thereafter he was acknowledged and respected by all whose lines of duty brought them into contact with him, as a thoroughly skilled mechanic, a faithful and efficient motive power officer, and a man who, in his dealings with his subordinates, was always both just and kind. Those who enjoyed his intimate acquaintance will never forget the amiability of his private character, his domestic virtues, and the depth and fidelity of his attachment to his friends. He was plain and unaffected in his speech and bearing, and united the truth and simpleheartedness of a child with the sound and experienced judgment of a manager of men. His friendship and confidence were seldom extended to any but those who had given sufficient evidence of their worthiness of them, and to such he was always a kind and generous friend, and a companion whose genial disposition and fund of good humor, anecdote, and information on mechanical matters rendered their meetings with him both enjoyable and instructive. His memory will always be cherished with affectionate recollection by those who knew him best, and merits a more fitting and expressive tribute than the mere expression of the writer's personal regard and grateful remembrance of the kindness and encouragement which he very many times received from him.

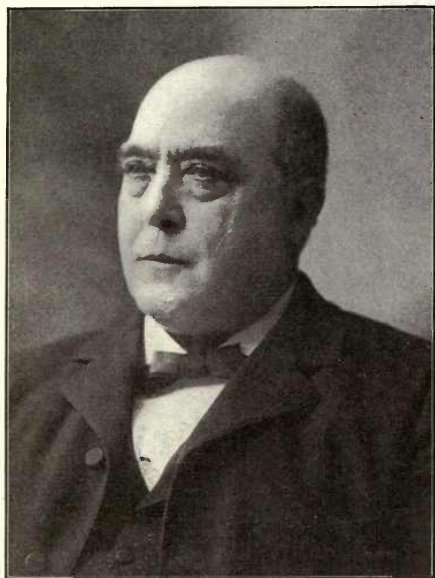

A. J. CROMWELL.

Baltimore & Ohio Railroad Company as machinist in the bridge department at Mount Clare shops, Baltimore. He soon became expert in this line of work and was promoted to erecting foreman, in which capacity he had charge of the erecting of several large bridges for the road, namely, those over the Cheat River, at Rowlesburg, W. Va.; over the Monongahela River, at Fairmont, W. Va., and over Wheeling Creek, at Wheeling, W. Va., leading to the passenger and freight depot at that point.

Preferring the locomotive department of the service, he requested to be transferred to it, and accordingly entered the Company's shops at Cumberland, Md., in 1854, as a journeyman machinist. He was promoted to gang foreman the same year, and successively to general foreman, in 1856, and Master Mechanic in charge of Cumberland shops in 1858. He held the latter position until July, 1865, performing arduous duties during the period of the Civil War, and in 1865 was promoted to Master Mechanic at Piedmont, W. Va., at which point much work was done at that time in heavy repairs to rolling stock and building new freight cars.

ANDREW J. CROMWELL was born at Krebs Bridge, Anne Arundel County, Md., near Baltimore, June 26, 1831, and was the son of Oliver Cromwell, of Baltimore County, and his wife, formerly Miss Helen Warfield, of Anne Arundel County. After receiving a common school education, he began his mechanical training as a machinist apprentice with the Granite Company, which was engaged in building cotton mill machinery at Ellicott's Mills, Md. This company went out of business in 1851, and he then entered the service of the

In November, 1874, Mr. Cromwell was transferred to Mount Clare shops, Baltimore, as Master Mechanic, and held that position until January, 1881, when he was appointed Assistant Master of Machinery of the lines East of the Ohio River, and in June, 1884, was made Master of Machinery of the lines East of the Ohio River. In 1887 his title was changed to Superintendent of Motive Power, and he held this position until his retirement from active service in June, 1896. His death, which was due to the infirmities of old age, occurred April 9, 1907, in the 76th year of his age.

Mr. Cromwell was a man of first-class mechanical ability, strong personality, and an earnest and faithful officer, and he was noted for such fairness and impartiality in the performance of his duties as commanded the respect and fidelity of his subordinates. He was a member of the Methodist Protestant Church, of the Masonic Order, and from 1885 to the time of his death, of the American Railway Master Mechanics Association. He was survived by his wife, formerly Miss Margaret Ann Holliday, of Bunker Hill, near Martinsburg, W. Va., seven sons and one daughter. His oldest son, Oliver C. Cromwell, has been for a number of years Mechanical Engineer of the Baltimore & Ohio Railroad.



# INDEX.

---

- "Arrow" first inside connected engine, 41.
- "Atlantic" first "grasshopper" engine, succeeding original "York," 1832, 17-19.
- "Arabian," "grasshopper" engine, 1834, 19.
- Baldwin, M. W., engine "Dragon" No. 51, 0-8-0 type, built by, in 1848, 58.
- "flexible beam truck" of, 59.
- 0-6-0 engines by, 87.
- 0-8-0 engines built to Company's specification by, 62, 63.
- modification of contract with, for 0-8-0 engines, 65, 66.
- Baltimore and Ohio Railroad, chartered February 28, 1827, 1.
- construction commenced July 4, 1828, 4.
- recognition of pioneership of, by American Railroad Journal, 1835, 2.
- approval of Cooper's experimental locomotive in Fourth Annual Report, 5, 6.
- periods of opening to various points, 9.
- extract from speech of Thomas Swann as to working heavy grades on, 9, 10.
- statement of new locomotives for, in 1852, 10.
- locomotives in service on, October 1, 1860, 11.
- advertisement for locomotives by, January 4, 1831, 13-15.
- description of first practical locomotive of, the "York," 16.
- locomotives in service on, Oct 1, 1834, 20.
- advertisement for locomotives by, September, 1847, 61, 62.
- old drawing illustrative of 1847 advertisement, 64.
- "Camel" engines, by Ross Winans, characteristics of, 71.
- short furnace class, 71.
- M. N. Forney's remarks on boiler of, 73.
- medium furnace class, 72.
- long furnace class, 74.
- valve gear of, 78, 82.
- variable exhaust of, 82, 84.
- Campbell, Henry R., patent granted to, February 5, 1836, covering 4-4-0 type locomotive, 35.
- "Centipede" 4-8-0 engine by Ross Winans, description of, 122, 123.
- "Coal crab" engines, description of, 22, 29.
- latest form of, 29, 30.
- Colburn, Zerah, remarks as to Rainhill test, 1.
- remarks as to experience of B. & O., being consulted by Austrian engineers who laid out the Semmering line, 4.
- statement of "original improvements" of American engineers, 31.
- remarks as to "Camel" engines, 70, 71.
- Cooper, Peter, description of experimental locomotive of, 7, 8.
- report of Ross Winans on experimental locomotive by, 8.
- Cromwell, A. J., biographical notice of, 153, 154.
- Davis, John C., mogul passenger engine No. 600 by, 131, 132.
- Davis, Phineas, biographical notice of, 138, 139.
- Denmead, A. & W., and Sons, 4-4-0 engines by, 47.
- 4-6-0 engines by, 91.
- Dutch wagons," crank axle engines by S. J. Hayes, 41.

- Eastwick & Harrison, 4-4-0 engines built by, 38.  
reverse gear of engines by, 39.
- Equalizing lever, patented by Joseph Harrison, Jr., April 24, 1838, 36.
- Forney, M. N., remarks on boiler of "Camel" engines, 73.
- "George Washington," performance of, on inclined plane of Columbia R. R., 32.
- Gooch or "stationary" links, first applied on Tyson ten-wheel engines, 95.
- "Grasshopper" locomotives, description of first, the "Atlantic," 17-19.  
illustration and characteristics of, 20, 21.  
application of horizontal cylinders to, 22-29.
- Harrison, Joseph, Jr., patent to, for equalizing lever, April 24, 1838, 36.
- Harrison, Wm. H., biographical notice of, 151, 152.
- Hayes, Samuel J., "Hayes ten-wheelers" by, 88.  
biographical notice of, 145, 146.
- "Indian Chief" engine by Davis & Gartner, 1833, 19.
- Jervis, John B., invention of swivelling leading truck by, 31.  
description of Jervis original truck, 31, 32.
- Latrobe, John H. B., remarks as to pioneership of B. & O. R. R., 3, 4.  
description of Cooper experimental engine by, 7, 8.
- Latrobe, B. H., account of 1831 engine tests, 11.
- Lawrence Manufacturing Co., crank axle engines by, 41.
- Link motion, shifting, first used on Mason engines, 1856, 47.  
Gooch or "stationary," first used on Tyson ten-wheelers, 1857, 95.
- Locomotives—Types of  
0-4-0 type ("Grasshopper" and "Crab"), 13-30.  
4-2-0 type (Wm. Norris), 31-34.  
4-4-0 type (various builder), 35-54.  
0-8-0 type (various builders), 55-86.  
0-6-0 type (M. W. Baldwin), 87.  
4-6-0 type (various builders), 88-98.  
Campbell Patent for 4-4-0 type, 35.  
designs intermediate between early and modern power, 124-132.  
present motive power, 133-137.  
Baldwin, built under advertisement of September, 1847, 62, 63.  
New Castle Manufacturing Co., same design, 67.  
Ross Winans' "Mud Digger," 57.  
Ross Winans' "Camel," 70-86.  
"Company's eight-wheel," 69, 70.  
2-6-0 passenger No. 600, 131, 132.
- Mason, Wm. & Co., first engines by, Nos. 25 and 26, November, 1856, 46.  
engines Nos. 231 to 236, inclusive, built by, August, 1857, 50.  
characteristic features of their typical engine, 50.  
boiler of engines by, 52.  
bed plate or saddle first applied by, 52-54.
- New Castle Manufacturing Co., 4-4-0 engines by, 41.  
engine "Arrow," first crank axle on road, 41.  
engine "Saturn" No. 56 by, 67.
- Norris, William, 4-2-0 engines by, 33.  
dimension schedule of, 34.
- Norris, Richard & Son, 4-4-0 engines by, 40, 41.
- Perkins, Thatcher, tire fastening by, 66.  
feed water heater by, 67, 68.  
4-6-0 passenger engines of, 124.  
combustion chamber boiler of, 126.  
4-4-0 passenger engines of, 128.  
0-8-0 freight engines of, 128, 130.  
biographical notice of, 149, 150.
- Reverse gear, Eastwick & Harrison's, 39.
- Taunton Manufacturing Co., engine No. 27 by, 47.
- Thomas, Evan, sailing car by, 5.
- Tire fastening, Perkins & McMahon Patent, 66.
- "Traveller" engine by Davis & Gartner, 1833, 19.
- Truck, leading, invented by John B. Jervis, 1832, 31.  
adopted in early Norris and Baldwin engines, 32.
- Tyson, Henry, Mason engines introduced by, 47.

- engine No. 188, Mason pattern by, 52.
- "Tyson ten-wheelers" by, 92.
- controversy with Ross Winans as to "Camel" vs. ten-wheel engines, 92-122.
- description of 4-6-0 engines of, 95.
- biographical notice of, 147, 148.
- Variable exhaust, Ross Winans', 82-84.
- E. R. Addison's, 85, 86.
- Winans, Ross, "assistant of machinery," 1831, 20, 139.
- operation of Company's shops by, in firm of Gillingham & Winans, 21, 22.
- patents of, relating to "coal crab" engines, 22-29.
- 4-4-0 engines by, 40.
- 0-8-0 engines by, for Western R. R. of Mass., 55.
- builder of first successful coal-burning engine with horizontal boiler, in 1844, 56.
- "Mud Digger" engines by, first of 0-8-0 type on B. & O. R. R., 57.
- "Camel" engines of, 70-84.
- controversy with Henry Tyson, 92-122.
- biographical notice of, 140-144.
- "steam gun" made by, 143.
- "York," first practical locomotive of B. & O. R. R., 11.



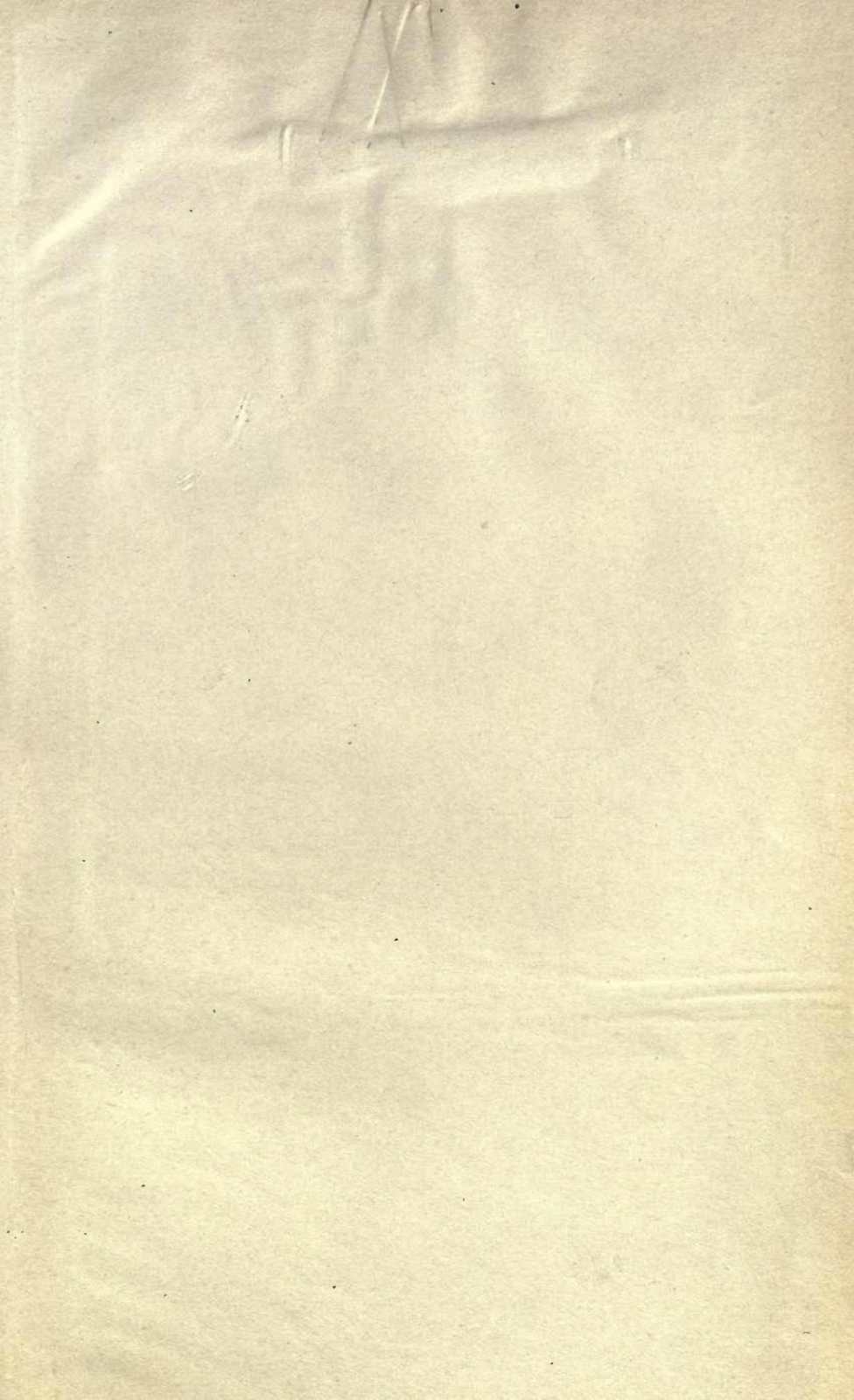

IBR

BERKELEY

**RETURN CIRCULATION DEPARTMENT**

**TO → 202 Main Library**

LOAN PERIOD 1	2	3
<b>HOME USE</b>		
4	5	6

**ALL BOOKS MAY BE RECALLED AFTER 7 DAYS**

RENEWALS AND RECHARGES MAY BE MADE 4 DAYS PRIOR TO DUE DATE  
LOAN PERIODS ARE 1-MONTH, 3-MONTHS, AND 1-YEAR

RENEWALS: CALL (415) 848-3803

**DUE AS STAMPED BELOW**

AUTO DISC OCT 21 '90

AUTO DISC OCT 23 '90

248548

TJ 603  
B3

Bell

GENERAL LIBRARY - U.C. BERKELEY



B000957534

