

# Earth

---

# Science

---

*a physiography*

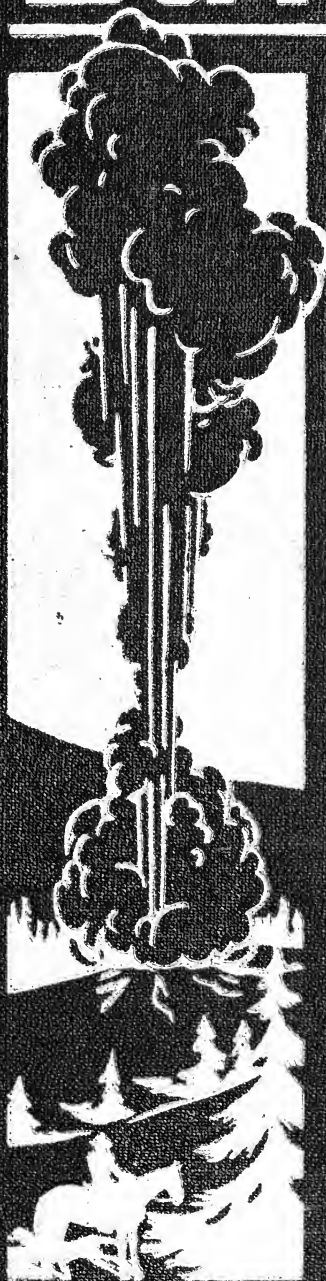

*by*

**Gustav L. Fletcher**

*based on NEW PHYSIOGRAPHY by*  
ALBERT L. AREY - WILLIAM W. CLENDENIN  
FRANK L. BRYANT - WILLIAM T. MORREY











*Published by permission of the National Geographic Magazine. Copyright, 1906.*

THE CORONA

# EARTH SCIENCE

## A PHYSIOGRAPHY

BY

GUSTAV L. FLETCHER

BASED ON *NEW PHYSIOGRAPHY* BY

ALBERT L. AREY

WILLIAM W. CLENDENIN

FRANK L. BRYANT

WILLIAM T. MORREY



D. C. HEATH AND COMPANY

BOSTON

NEW YORK

CHICAGO

ATLANTA

SAN FRANCISCO

DALLAS

LONDON

COPYRIGHT, 1938,  
BY D. C. HEATH AND COMPANY

---

No part of the material covered by this  
copyright may be reproduced in any form  
without written permission of the publisher.

4 J 1



## PREFACE

This text is based upon *New Physiography* by Arey, Bryant, Clendenin, and Morrey. It retains the good features of the older text, but the order of topics has been entirely changed, most of the illustrations are new, and the subject matter has been completely rewritten. The author's long experience with high school pupils has made him aware of their difficulties with the printed text, and mindful of that, he has tried to use language within their comprehension.

The introductory chapter gives a general idea of what has happened on the earth and what is going on now, so that the pupil is made aware of the aim of the entire subject. This is followed by a study of the materials of which the earth is made, rocks, and of the forces acting upon those materials. Having learned that much, the pupil is in a position to understand how these forces have modified the earth's surface and made it what it is today.

The land is studied first, because pupils are more likely to know something about land, to begin with. It is for that reason they find land studies easier than the rest of the subject.

This is followed by a short history of the earth, designed to teach the student how the earth came to its present condition. The chapter is optional, but the author feels that many of the better students will be eager to read it.

The study of the land will probably occupy the first half of a year. The pupils who have successfully completed the first half will then study the earth's relations in space, seasons, latitude, longitude, time, the atmosphere and associated phenomena like weather and climate. And the year's work is brought to an end by the study of the sea with special emphasis on harbors.

The text is printed in type of two sizes: larger type for the essential material and smaller for the optional. Each chapter has a *completion summary* which the pupil is required to copy and complete. This avoids the objection that many teachers have to the ordinary summary: that some pupils read *only the summary*. The completion summary acts as a self-test, for if the pupil is able to fill in the blanks, he knows that he has learned his lesson and this knowledge carries with it a sense of mastery and hence a feeling of satisfaction.

At the end of each chapter are questions on every important point in the text and the teacher may well use these questions as a chief part of his assignment. There is also a set of optional questions which will challenge the best students to extend themselves.

Summaries in tabular form are used wherever the complexity of the subject seemed to require them, as, for example: the cycle of stream erosion, page 91; classification of rocks, page 24; ground water, page 150; harbors, page 525.

The author believes that illustrations should be used chiefly to help the pupil understand the text, and he has therefore been at great pains to use illustrations wherever they would help: for example, Fig. 263, page 393, on the cause of cyclones, Fig. 285, page 424, on the rainbow, and Figs. 189 to 196 in "Stories in Stones."

Several new topics have been introduced into the book: flood control, soil erosion, and dust storms are shown to be related to each other and to the problems of irrigation and water power. "Stories in Stones" is a short history of the earth never before attempted in a book of this kind. The chapter on "The Economic Importance of Rocks and Minerals" is also new.

Besides the newer phases of the subject, many of the older topics are treated in new ways.

There is a clear analysis of rocks and the relation of each class to the others.

The chapter on rivers has a logical development.

Earthquakes, volcanoes, and mountains are all related to each other and to the margins of the continents, where crustal movements are taking place.

Geysers are explained as similar in action to coffee percolators. An attempt is made to explain the cause of the cyclonic whirl. The monsoon is shown to be nothing but a land breeze on a continental scale.

Lightning is discussed in a practical way.

Climates are classified scientifically, following Finch and Trewartha's up-to-date treatment.

Relative humidity, dew point, frost, fog, cloud, rain, and snow are all treated as related topics.

The author wishes to express his thanks to Mr. Abraham Fialkoff of the New Utrecht High School, Brooklyn, N. Y., for his constructive criticism of the manuscript; and to Mr. Chas. Halgren, whose painstaking work with the illustrations is largely responsible for their success.

# CONTENTS

CHAPTER	PAGE
1. EARTH, THE HOME OF MAN . . . . .	3
2. ROCKS AND MINERALS . . . . .	11
3. ECONOMIC IMPORTANCE OF ROCKS AND MINERALS . . . . .	27
4. WEATHERING . . . . .	40
5. ROCK MANTLE AND ITS MOVEMENTS; SOIL AND SOIL EROSION . . . . .	46
6. RUNNING WATER . . . . .	63
7. RIVERS . . . . .	73
8. FLOODS AND FLOOD CONTROL . . . . .	99
9. GLACIERS . . . . .	107
10. THE GROUND WATER . . . . .	131
11. LAKES AND SWAMPS . . . . .	153
12. PLAINS . . . . .	167
13. PLATEAUS . . . . .	187
14. MOVEMENTS OF THE EARTH'S CRUST . . . . .	192
15. MOUNTAINS . . . . .	203
16. EARTHQUAKES . . . . .	228
17. VOLCANOES . . . . .	238
18. ✓STORIES IN STONES . . . . .	257
19. THE EARTH IN SPACE . . . . .	290
20. LATITUDE, LONGITUDE, AND TIME . . . . .	309
21. THE MOON . . . . .	322
22. THE SOLAR SYSTEM . . . . .	330
23. PROPERTIES AND FUNCTIONS OF THE AIR . . . . .	349
24. THE TEMPERATURE OF THE AIR . . . . .	358
25. AIR PRESSURE . . . . .	375
26. WINDS . . . . .	384
27. MOISTURE OF THE AIR . . . . .	405
28. LIGHT AND ELECTRICITY OF THE AIR . . . . .	419
29. WEATHER AND CLIMATE . . . . .	433
30. CLIMATES OF THE UNITED STATES . . . . .	460
31. GENERAL CHARACTERISTICS OF THE SEA . . . . .	476
32. MOVEMENTS OF THE SEA . . . . .	487
33. SHORE LINES AND HARBORS . . . . .	513
APPENDIX . . . . .	535
GENERAL REVIEW QUESTIONS . . . . .	544
HELPFUL REFERENCE BOOKS . . . . .	556
INDEX . . . . .	561



EARTH SCIENCE  
A PHYSIOGRAPHY



## CHAPTER I

### EARTH, THE HOME OF MAN

1. **What is physiography?** Education may be defined as the process which fits a person for the life he has to lead. In many respects we cannot predict what that life will be and therefore we cannot prescribe the proper kind of education. But we all live on the surface of the earth and it would seem that knowledge about that surface ought to make up an important part of everyone's education. What is the surface like at the present time? What kind of change is it likely to undergo today, tomorrow, next month, next year, in the near future, and in the distant future? For things do not remain the same for very long. In the words of the old hymn, "Change and decay in all around I see."

To be more specific, what kind of an earth is this on which we live?

What is it made of?

Can we make use of any of the materials of which it is composed?

What changes will they undergo?

What is the relation of continents and oceans?

Is that relation likely to change?

Will the mountains always remain as they are?

What are earthquakes?

What causes the seasons?

Can we predict the weather?

Why does it rain?

How is climate determined?

These are a few of the questions which physiography tries to answer; and if we summarize them we might say: *Physiog-*

raphy is the study of the face of the earth, the home of man, and the changes in physiognomy which that face undergoes.

**2. The earth in space.** The earth is a member of the solar system, consisting of the sun and nine other heavenly bodies called *planets* (Fig. 1).

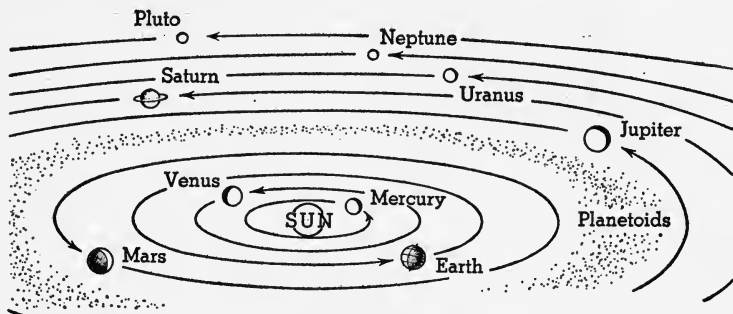

FIG. 1. The Solar System

The earth, as well as the other planets, moves about the sun in a path which is almost circular, and in a plane, called the *ecliptic*, which almost coincides with the sun's equator.

**3. The origin of the earth.** The sun and all the planets are composed of the same elements, as shown by spectroscopic analysis. This evidence would lead us to the conclusion that these bodies have had a common origin, and all the hypotheses about the origin of the earth start that way. These hypotheses will be taken up, in detail, in a later chapter; but it is necessary, here, to indicate how we believe the earth attained its present condition, in order that we may understand some of the changes that are going on now.

We believe that the present solar system started as a large mass of very hot gas, much like the present sun, and including all the other bodies of the present solar system.

Some event took place which tore out masses of this hot material and started the rotation which still continues, since there is nothing to stop it. These masses cooled to



form the planets, and, according to the Jeans and Jeffreys version, as well as the nebular hypothesis, the mass which is now the earth was at one time liquid.

The liquid mass cooled, on the surface, to form a solid crust, but it remained very hot inside. However, we have evidence to prove that the earth is a very rigid solid inside, despite its great heat; and this is in perfect accord with scientific principles; for at the great pressure of the underlying rock, the melting point of the rock is raised. In other words, it takes a much higher temperature to melt rock which is under great pressure. But if that pressure were released, for example, by the cracking of the crustal covering, then the interior material would become liquid as we see it sometimes in volcanic eruptions.

**4. The origin of the continents.** Let us imagine the earth as it must have been, if our hypothesis is correct, a ball of very hot gas, consisting of all kinds of material, most of which now is either liquid or solid. As it cooled more and more, most of the gas became liquid, which collected together in the form of a ball surrounded by the remaining gases.

As the liquid, consisting of a mixture of all sorts of molten substances, cooled sufficiently, some of these substances began to separate out as solids. The very dense solids, like iron, sank in the liquid, while others floated about like great icebergs, some sticking out of the liquid higher than others, like cork and wood and ice floating in water (Fig. 2).

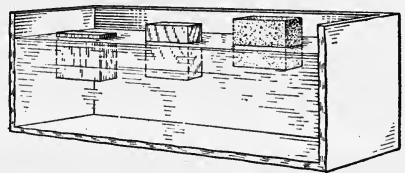

FIG. 2. Ice, Wood, and Cork Floating in Water

The cork is higher than the ice because its specific gravity is less.

Now we find that the earth's crust is composed chiefly of two kinds of rock, which we call by the general names of *granite* and *basalt*. The granite, with a specific gravity of 2.7, and the basalt with a specific gravity of 3.0 both floated in the liquid earth mass,

whose specific gravity was about 5.7; but the granite stuck out farther, like cork in water, while the basalt floated like wood (Fig. 3).

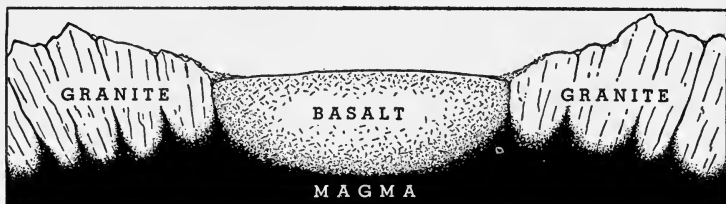

FIG. 3. Masses of Granite and Basalt Floating in Liquefied Rock or Magma

When the entire surface had cooled to a solid, it must have been irregular and have consisted of masses of granite and basalt, with the former standing higher than the latter. Now on further cooling, there came a time when the water, all of which must have been in the atmosphere as steam, began to fall as rain, boiling hot rain, which at first evaporated from the hot rocky surface of the earth. But ultimately, some of the hot water remained on the earth, running down from the high places into the lowest ones; from the granite masses on to the basalt (Fig. 4).



FIG. 4. Formation of Oceans and Continents

This figure also shows how the pressure of sediments formed by erosion pushes the basalt down and the granite up, re-elevating the mountains.

If this were true, the continents should be made chiefly of granites while the oceans should rest on basalt, and this appears to be the case. Ever since that first rain fell, water has been evaporating from the ocean, falling as rain, and running down from the continents to the ocean again.

5. **The theory of isostasy or balance.** The action of air and water on the granites, in time, wore off pieces, small and large, which the rain water moved downhill toward the ocean; slowly in most cases, rapidly in others where the slope was steep. The running waters, or rivers, pushing along the loose bits and pieces of rock, ground down the bedrock and wore it still more, just as a file wears down a piece of iron. In time, millions of years in most cases, the high places of the continents, the mountains, were worn down, since the wearing process is most rapid where the slope is steepest.

The loose material carried by the rivers was ultimately dragged down to the seas, ground down to sand and silt, and this material was deposited at the mouths of the rivers, the coarser material nearer the shore, the finer material a little farther out, but none of it very far from shore, because, as soon as the river flows into the ocean, it slows down and soon stops moving altogether, so that it can no longer push particles of sand or even silt.

The process we have been describing, called *erosion*, planes down the high places of the continents and carries the debris into the seas, dropping it close to the shore — on the *continental shelf*, as we call it (Fig. 5).

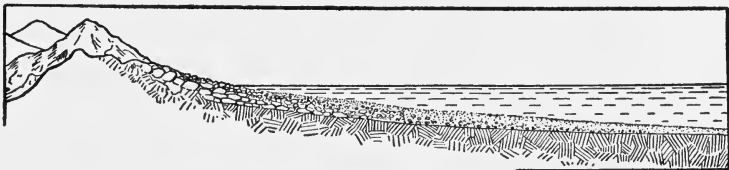

FIG. 5. Loose rock, formed by erosion, is deposited near the shore.

When these mountainous masses have been deposited on the continental shelf, they create a pressure on the underlying basalt. (See Fig. 4.) It will be remembered that the rock underneath the crust is solid but very hot; and we have reason to know that it is plastic. Now just imagine a ball composed of plastic material with a thin cover, the crust, and two pieces of wood sticking through the crust into the plastic

material. If one piece of wood is pushed *in*, the other will be pushed *out* until the pressures throughout are again equal (Fig. 6). We call this an *isostatic adjustment*.

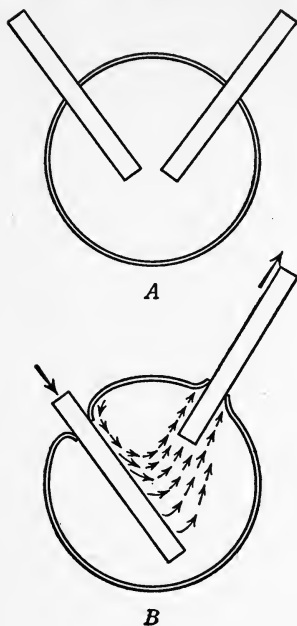

FIG. 6

And where would that adjustment take place, if our theory is correct? The granite masses have been worn off and thrown upon the basalt, which therefore must sink deeper, pushing up the underlying granite mass into mountains again. This should take place at or near the contact between the granite and the basaltic masses, that is, near the shore line, and that is just where our mountain ranges are formed; *parallel to the shore lines* (Fig. 7).

This plausible explanation of the origin of the continents and of mountains is called *the theory of isostasy* and we are developing it early in the course, because it will

help us to understand many of the forces that seem to be at play, changing the face of the earth. Isostasy means literally *equal pressures* or balance. The earth's crust is composed of granite and basalt blocks which are balanced. When the basalt block is made heavier, it sinks down and pushes up the granite block until balance is again restored.

### Completion Summary

Physiography is an important subject because ——.\*

The earth was at one time in the —— condition, and although —— even now, we have evidence that it is a solid.

We believe that —— liquids began to separate from the

\* The student is required to copy this summary, filling in the blanks with the correct word, phrase, sentence, or paragraph.



FIG. 7. North America, Showing the Mountain Ranges  
Parallel to the Shore Lines

gaseous mass; and as the liquid cooled, the —— separated from it, sinking to the center, if they were ——, or floating, if ——.

The lighter solids were chiefly of two kinds: —— and ——; of which the —— stuck out farther than the ——.

Subsequent rains —— basalt, forming oceans, while the granite masses ——.

Erosion wore down the granitic mountain masses and deposited the sediments ——.

The pressure brought about —— in the hot, plastic ——, and ultimately —— mountains again.

*Exercises*

1. State two reasons for your belief that physiography is going to be an interesting study.
2. Give a brief outline of the origin of the earth.
3. What is our present belief concerning the nature of the interior of the earth?
4. How do we explain the fact that the continental masses are chiefly granite?
5. Explain how the oceans were formed.
6. How are mountains worn down? (Use the word *erosion*.)
7. If the mountains have been worn down in the past, why is it that we still have mountains? Explain, using the theory of isostasy.

## CHAPTER II

### ROCKS AND MINERALS

**6. Composition of the crust of the earth.** In order to understand what is going on, we must also know something of the nature and properties of the materials that make up the surface of the earth. In its original gaseous state, we believe there were only the chemical elements, about ninety-two in number. About half the total amount seems to have been oxygen, a gas, and about one quarter silicon, now a solid. The others are shown in Fig. 8. These figures are based upon analyses of minerals throughout the world, all of them derived from the crust and from lavas which may have come from the depths of the earth.

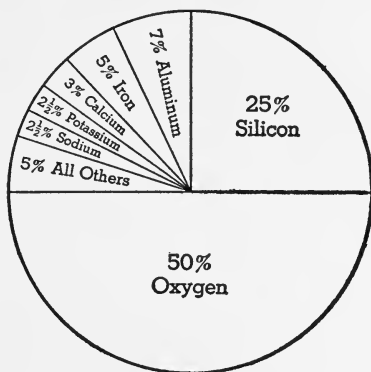

FIG. 8. Composition of the Earth

As these hot gaseous elements cooled, some of them combined with others, forming compounds like water, silica, better known as quartz, and thousands of others, in some places separated from each other, in most places mixed up with each other.

**7. Rocks and minerals.** A simple element or compound found in the earth, but not formed by plant or animal, we call a *mineral*. Quartz is a mineral. It is composed of silicon and oxygen and always has the definite chemical composition  $\text{SiO}_2$ . In chemistry, such a substance is called a compound, because it always has the same composition, while in geology we call it a *mineral*. According to this definition we

must even consider water a mineral, because it is a definite compound, found in the earth.

The earth's crust is made of *rocks*, and these, as we have seen, consist chiefly of *mixtures of minerals*. Granite, for example, is a rock composed of at least three minerals: quartz, feldspar, and mica.

Some rocks consist of only one mineral. *Limestone is called a rock, because it makes up whole areas of the surface of the earth*, but it consists often of only one mineral. Quartz, the most common mineral, is never formed in very large masses; it does not cover very large areas of the earth — never do we find even one whole mountain made of quartz. Therefore *quartz is not called a rock*. A rock is mineral matter found in the earth in large quantities.

To sum up then, the earth is made of rocks each of which is composed of minerals, usually more than one.

**8. Kinds of rocks.** If we go back to our theory of the formation of continents, we shall be able to understand how the different kinds of rocks arose.

The earth was at one time liquid, and it is still hot enough inside to become liquid under certain conditions. We believe the original crust of the earth was formed by the cooling of the liquid. Any rock derived from the molten condition we call *igneous* (Latin, *ignis*, fire), as, for example, the granitic continental masses and the basaltic rocks underlying the oceans.

The loose material carried down by rivers and deposited on the continental shelf as sediment becomes consolidated into rocks which we call *sedimentary rocks*. We include also under this head *any* sediments deposited from solution such as rock salt or gypsum; or from air, like dune sands; or from glacial ice, like tillite.

Both these kinds of rock, igneous and sedimentary, when subjected to the action of water, heat, pressure, movement, and other forces, are changed into what we call *metamorphic rocks* (from Greek words meaning *changed form*).



The earth's crust, then, is composed of three kinds of rocks, igneous, sedimentary, and metamorphic.

About three quarters of the continental area is covered by sedimentary rocks and in most places we see only these rocks on the surface; but wherever these sediments are worn off by long erosion, we find igneous or metamorphic rock underneath.

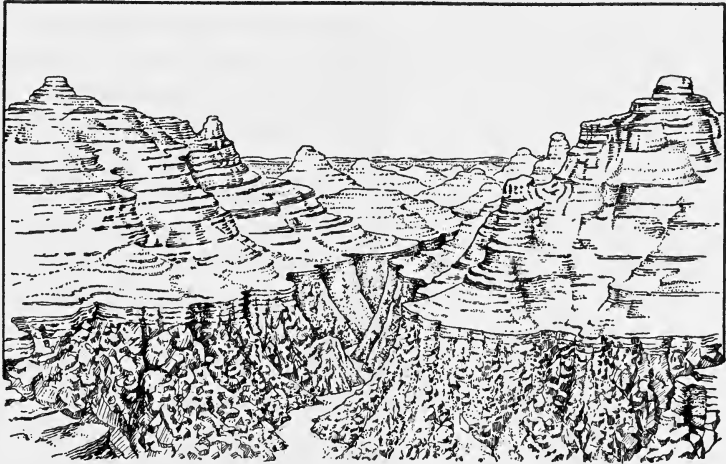

FIG. 9. The Grand Canyon

Underneath, near the river, the rock is metamorphic, while above we see sedimentary or stratified rock.

The sedimentary rocks, then, form only a thin surface covering, seldom more than a mile thick, over the igneous or metamorphosed crust. This is well shown on the Grand Canyon where we have a mile of sediments underlain by metamorphic rocks (Fig. 9).

**9. Igneous rocks.** Whenever material cools from the liquid condition to the solid, it usually forms crystals. If the cooling is slow the crystals are large; if rapid, they are small. Igneous rocks therefore contain minerals in crystal form.

When the molten rock is poured out on the surface, it cools rapidly, and the crystals are small. If the igneous mass

is forced into the rock, perhaps miles below the surface, it cools slowly and the crystals are large. When the surface covering is worn off, these rocks are laid bare.

Igneous rocks are usually easy to distinguish because they are *massive*, as we say. That is, when looking at a wall or a cliff of igneous rock, no banding or stratification will show (Fig. 10). The entire rock seems to be uniform.



FIG. 10. Igneous Rock  
It is not stratified.

However, upon examining a hand specimen, it is not so easy as that, since a piece of sedimentary rock shows no layers, either. But neither does the sedimentary rock show crystals. We can distinguish a specimen of igneous rock, therefore, by the crystals, since sedimentary rocks do not, as a rule, contain crystals. Igneous rock is also much harder than most sedimentary rock.

The hand specimen of igneous rock shows a uniform distribution of crystals, which may, however, be too small to see without a glass or microscope.

There are two classes of igneous rocks: light colored or acidic rocks like *granites*, and dark colored or basic rocks called *gabbros* or *basalts*.

**10. Coarse-grained igneous rocks.** Ordinary granite usually consists of at least three minerals: quartz, mica, and feldspar.

The quartz and feldspar are light colored and the mica may be, too; but it is often black. Yet on the whole the

general effect of a granite is that of light color. It usually has a granular appearance, and in fact, if the crystals are much larger than usual or much smaller, it is not popularly called granite. When the crystals are very large, sometimes up to many inches in diameter, the rock is called *pegmatite*. It is from pegmatites that we get large pieces of mica or feldspar as specimens.

Most people use the name granite for any granular igneous rock, although strictly if there is no quartz, the rock should be called either syenite, diorite, or gabbro. Diabase is a rather fine grained, dark colored igneous rock, often called *trap*. The word trap is derived from the Swedish *trappar*, which means steps. The rock is apparently so called because of its columnar structure which gives it the appearance of steps (like the Giant's Causeway in Ireland, and the Palisades on the Hudson River near New York City).

### 11. Other igneous rocks.

When the grains of the mineral are unequal in size, so that one kind of crystal stands out from a background of the rest, we call the rock a *porphyry* (Fig. 11). We believe such rocks were formed in two different locations; at first, cooling of the molten rock or *magma* took place very far below the surface, forming the large crystals, but before the entire mass could crystallize, it was transported to a new location nearer the surface. Here the cooling took place more quickly, forming smaller crystals. When the crystals are so small that they cannot be seen with the naked eye, the rock is called *felsite*; and when no crys-

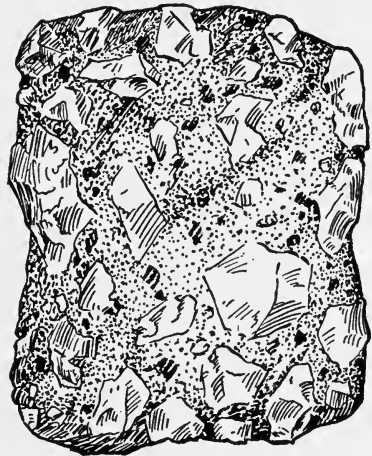

FIG. 11. Porphyry, an Igneous Rock Containing Large Crystals Set in a Background of Small Crystals

tals are seen even under the microscope, the rock is called a glass. *Obsidian* is a glass that has been poured out on the surface and hence chilled very rapidly, so that no crystals formed.

**12. Sedimentary rocks.** Most sedimentary rocks were formed by erosion of other rocks. The action of air and

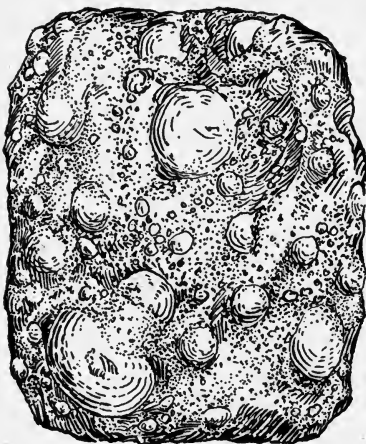

FIG. 12. Coquina, a Conglomerate  
Made of Shells

water causes exposed rocks to crumble, and the rain water gradually moves the pieces downhill. After movement has ceased, some substance in solution in water deposits a cementing material which holds the pieces together to form a rock. If the pieces are large we call the rock a *conglomerate*. Pieces about the size of sand grains form a *sandstone*. When the mass is like a fine smooth powder, the rock becomes a *shale*.

Conglomerates may contain pieces of any kind of rock. Usually the pieces are rounded because they were worn by movement from their original position on a hill to their final resting place, perhaps many hundred miles away. Very few minerals can stand being transported such distances; they wear down to powder before they get to their ultimate resting place. Quartz is one of the most common minerals and it is very hard; therefore conglomerates and sandstones are usually composed of quartz. However, the coquina of Florida is a limestone conglomerate (Fig. 12).

Shale is composed of the smallest particles, which remain suspended even in quiet water, and that material is chiefly clay. The term shale is derived from the German word *schale*, a shell, used to denote the fact that shales often

break off in layers shaped slightly like a shell. Some shales do not show the shelly fracture and seem to be nothing but slightly consolidated mud. These are called *mudstones*. Sometimes a little sand will find its way into the mud and then it is called a sandy shale.

Since the sedimentary rocks are deposited from water they form horizontal layers or *strata*, and this stratification is very noticeable at a distance (Fig. 9) where one can see a layer of conglomerate topped by a layer of sandstone, for example. But it is a mistake to think that *sedimentary rocks show layers* and then expect to find such layers in a single piece of conglomerate (Fig. 12). The strata as originally laid down are horizontal, but subsequent earth movements may tilt them up at an angle and also bend and twist them.

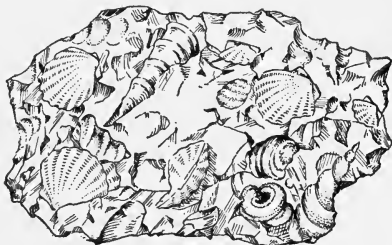

FIG. 13. Specimen of Limestone, Showing Fossils

*Limestone* is often formed from the shells of marine animals, and it is from these specimens or fossils that we learn something of the life of bygone periods of the earth's history (Fig. 13). When formed quite near the shore, mud may be mixed with the shells, and it gives the mass a gray color. We call this rock shaly limestone or if it is chiefly shale, calcareous shale. Chalk is a form of limestone made up of the shells of microscopic animals.

★Limestone,\* which chemically is calcium carbonate,  $\text{CaCO}_3$ , is precipitated from marine waters containing calcium acid carbonate,  $\text{Ca}(\text{HCO}_3)_2$ , in solution; when this solution is warmed, carbon dioxide,  $\text{CO}_2$ , is driven off according to the equation:  $\text{Ca}(\text{HCO}_3)_2 \rightarrow \text{CO}_2 + \text{CaCO}_3 + \text{H}_2\text{O}$ . This forms a limy mud, which is very fine grained; and most limestone has this origin. All kinds of limestone bubble when acid is applied.

\*Text in smaller type, marked by a ★, is not essential and may be omitted.

**13. Other sedimentary rocks.** The four types of sedimentary rocks already mentioned, conglomerate, sandstone, shale, and limestone make up the chief portion of the sedimentary rocks of the earth. But some of the rarer sediments are of considerable economic value. We shall say a word here about each of the following sediments: rock salt, gypsum, certain kinds of coal, and some iron ores.

**14. Rock salt.** The largest salt deposit in the world, with an area 650 miles by 200 miles, is found in the rocks of Kansas, Oklahoma, Texas, and New Mexico. It is about 300 feet thick. Much salt is also found in New York and Michigan.

In Europe there are large deposits of rock salt near Cracow, Poland, and the enormous deposit at Stassfurt, Germany, yields the salt, potassium chloride, valuable for fertilizer.

In northern Chile, in the desert of Atacama, we find deposits of Chile saltpeter, sodium nitrate, which is very useful for fertilizer and for the manufacture of explosives and dyes.

Since the salt must have come from the evaporation of sea water, we believe the rock salt was formed while desert conditions prevailed.

The great Salt Lake of Utah and the Dead Sea of Palestine are probably now undergoing evaporation which will, in time, produce salt beds. These lakes are both in semiarid regions so that they do not receive as much water as evaporates, and, as a result, the per cent of salt increases from year to year.

★*Gypsum*, like rock salt, was deposited by evaporation of sea water. It is a soft rock and looks like some kinds of limestone, but it can easily be scratched by the nail and does not effervesce with acid. It occurs usually near the salt deposits in New York, Michigan, and Iowa.

★**15. Sedimentary iron ores.** Two important ores of iron, hematite and limonite, are often sedimentary. Hematite is red and limonite yellow or brown. The sedimentary types are more like red

or yellow earths. In fact the yellow, brown, or red color of many rocks and soils is due to iron compounds and in some places these compounds, dissolved out by water, have been precipitated in lakes or bays by the action of organic material.

**16. Sedimentary coal.** Coal is usually found interbedded with shale and sandstone and sometimes limestone, showing that it is of sedimentary origin. Coal is really carbonized plant remains, trees, roots, and leaves, and we often find fossilized plant remains in the coal.

★When trees fall in the forest, they usually decay or oxidize. The chief elements present in wood are carbon, hydrogen, and oxygen. On oxidation the carbon forms carbon dioxide while the hydrogen changes to water; nothing but a little ash remains. But when the tree is covered by water, so that oxygen cannot get at it, the chemical changes are quite different. Slowly some of the hydrogen and oxygen combine to form water, and some of the carbon unites with the hydrogen to form marsh gas or fire damp,  $\text{CH}_4$ , which is often found in coal mines. Thus gradually the hydrogen and oxygen are eliminated and the carbon is left.

Partially changed roots, leaves, and other matter when consolidated by pressure become *peat*. As the change progresses, brown coal or *lignite* is formed.

**17. Metamorphic rocks.** When any kind of rock is subjected to markedly changed conditions within the earth, usually heat, pressure, water, and motion, it is changed in many ways and we say it has been metamorphosed. In biology we speak of plants and animals adapting themselves to their environment. In geology we find, likewise, that rocks frequently adapt themselves to their environment. For example, under great pressure a rock takes up less room — it becomes denser, if it can; and sometimes if the chemical elements are present to form a new mineral, which is denser than any of those present, that change will take place. For example, graphite is more dense than coal; hence when coal is metamorphosed, graphite is often formed. Again limestone and marble are both calcium carbonate, but marble,

formed by metamorphism, is more dense than limestone. If the limestone contains silica as an impurity, then a new mineral, calcium silicate, is formed, which is denser than calcium carbonate.

Under heat and pressure, a sandstone, which is quite porous, is converted into a quartzite, in which the pores have disappeared; the edges of the grains of sand have been fused together. But it is under heat, pressure, and motion that we get the most profound metamorphism. We get more

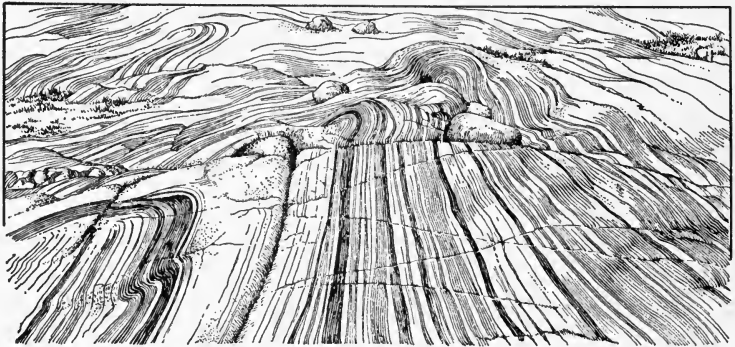

FIG. 14. Banded Metamorphic Rock

dense minerals, as before, but now the crystals arrange themselves in the direction of the movement, giving a banded appearance; those minerals are formed which have flat faces, like mica, and which are smooth, like talc and graphite. Shale becomes slate, which, under the microscope, reveals flakes of mica with their flat faces parallel to each other, producing the characteristic slaty cleavage or *schistosity*. Some minerals, like mica, and some rocks, like slate, break or split readily in one direction, leaving flat, shiny faces. This is called *cleavage*.

Metamorphic rocks often have a banded appearance due to segregation of minerals of one kind in layers, which at first sight give the appearance of strata (Fig. 14). These bands will often show in a small hand specimen. They can easily be distinguished from sedimentary rocks. Their con-



stituents are crystalline and hard, resembling igneous rocks. Igneous rocks, however, show no bands. Schistosity or foliation (Fig. 15) is characteristic of metamorphic rocks, but



*Photo by Keith, U. S. G. S.*

FIG. 15. Metamorphic Rock (Slate) Showing Foliation

there are some, like quartzite and marble, which do not show it at all. In both these cases, schistosity, which is due to segregation of different minerals, could not develop, since each rock consists of only one mineral. Quartzite is made entirely of quartz, and marble entirely of limestone.

**18. Kinds of metamorphic rocks.** The following table shows the sedimentary and igneous rocks from which the metamorphic rocks were formed.

SEDIMENTARY	METAMORPHIC	IGNEOUS	METAMORPHIC
conglomerate	gneiss	coarse granite	gneiss
sandstone	quartzite	fine-grained granite (felsite)	schist and slate
shale	slate and schist		
limestone	marble		hornblende schist
peat	coal	gabbro	and serpentine

A few words about each of these metamorphic rocks will be sufficient to make one acquainted with them.

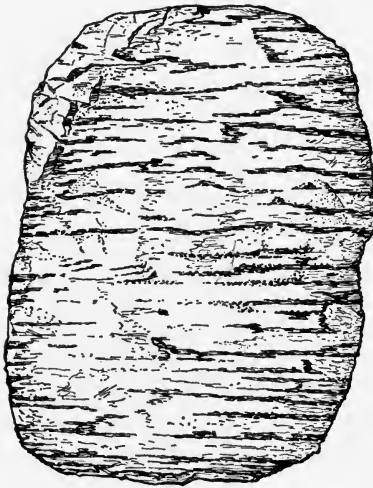

FIG. 16. Gneiss Showing Bands

*Gneiss* (pronounced nice) frequently looks like granite, and consists of quartz, feldspar, and mica with the minerals arranged in bands (Fig. 16).

*Quartzite.* A quartzite differs from a sandstone by being much less porous and much firmer. It looks rather glassy. The magnifying glass reveals the fusion of one grain of sand with the other, and, when broken, it will be found that the grains have fractured rather than separate from each other.

*Slate* is partially metamorphosed shale. It cleaves into thin plates, whence its use for roofing and blackboards.

*Schists* resemble gneisses except that the bands are thinner. They consist chiefly of quartz and mica and these are arranged in bands, producing schistosity.

*Mica schist* consists chiefly of mica. It often contains garnet as secondary mineral. When the amount of garnet is rather noticeable, we call the rock garnet schist. If it contains much talc, it is called *talc schist*. A rather common variety is *horn-*

*blende schist*, dark green or black, with hornblende crystals in parallel layers, imparting a silky appearance to the rock.

*Marble* is formed by metamorphism of limestone. It is crystalline, usually harder than limestone and therefore can be polished, but shows no banding or cleavage when pure. It is often white, but all varieties of colored marbles are found; the color is due to small quantities of impurities, which often are segregated in streaks. It is easily scratched by a knife and therefore is easily worked, which makes it an ideal medium for statuary, ornamental objects, and building stone.

*Coal*. We have mentioned the origin of sedimentary coal on page 19. When this is subjected to heat and pressure, bituminous coals are formed which contain less hydrogen than the brown coals, and more free carbon. They are dull black in color and crumble readily. *Bituminous* coal burns with a smoky flame. When the beds of coal are intensely folded we get a very compact coal called *anthracite*. It is almost free of hydrogen, contains about 90% free carbon, has a high luster, and burns without smoke.

### *Completion Summary*

A natural inorganic substance which is not a mixture is called a ———. Such a ——— must have the same ——— whenever or wherever we find it.

The crust of the earth is made of ———. Some ——— consist of one mineral; most rocks are composed of ———.

There are three classes of rocks: ———, ———, and ———. ——— rocks are formed from ——— material, sedimentary rocks from ———; metamorphic rocks may be ——— either.

The surface rocks are usually ———, while deeper down they are ———. Granite consists of ———.

Dark colored igneous rocks are called ———.

——— rocks are stratified, but the ——— cannot be seen in a hand specimen. Small specimens which seem to show stratification are ———. This arrangement of minerals in parallel layers is called ———.

Three kinds of sedimentary rocks are ———. These sedimentary rocks differ from each other in ———.

Rock salt is a ——— rock. It was formed ———.

Metamorphic rocks are formed from ——— or ———. They ——— igneous rocks, because they often show crystals, but they differ from igneous rocks ———.

The true coals are ——— rocks.

#### CLASSIFICATION OF COMMON ROCKS

KINDS OF ROCKS	ORIGIN	TEXTURE	TYPES
Igneous	Cooled from a molten state	Large crystals	Pegmatite
		Small crystals	Granite, diorite, syenite, gabbro, diabase
		Large and small crystals	Porphyry
		Compact (microscopic crystals)	Felsite, basalt
		Glassy (unformed crystals)	Obsidian, pumice, basalt glass
Sedimentary (stratified)	Deposited in water	Fragmental	Conglomerate, sandstone
		Compact	Shale, limestone, peat, some iron ores
		Crystalline	Salt, gypsum
Metamorphic	Igneous or sedimentary rocks, changed by heat, pressure, water, and movement	Coarsely banded and crystalline	Gneiss, schist
		Very fine bands	Slate
		Compact	Quartzite, anthracite
		Crystalline	Marble

*Exercises*

1. What is a mineral? Why do we consider water a mineral?
2. Name five minerals.
3. Name three rocks.
4. What is a rock? How does it differ from a mineral?
5. Why is not quartz considered a rock?
6. Name a rock which is also a mineral.
7. Name a mineral which is not a rock. Explain.
8. Name a rock which is not a single mineral. Explain.
9. Name the classes of rocks, with one example of each class.
10. How can one distinguish sedimentary rocks, in the field?  
Make a diagram to illustrate.
11. How can one tell an igneous rock in a hand specimen?
12. In what ways are igneous and metamorphic rocks alike?
13. How can one distinguish banding from stratification?
14. Describe a granite, both in composition and appearance.
15. How does a porphyry differ from a pegmatite?
16. Name the classes of sedimentary rocks, with one example of each class.
17. Why is sand usually made of quartz grains?
18. Why are sedimentary rocks stratified?
19. What is a shaly limestone?
20. Name a sedimentary coal. Why do we consider it sedimentary?
21. How are metamorphic rocks formed?
22. How do limestone and marble resemble each other? How do they differ?
23. How do sandstone and quartzite differ?
24. Explain how the banded appearance of some metamorphic rocks has been brought about.
25. What is schistosity? How does it arise?
26. Name three kinds of metamorphic rocks and tell how each was formed.
27. In what way is gneiss like granite? In what is it different?
28. How can one distinguish a schist from a gneiss? from a sedimentary rock?
29. How is bituminous coal formed from peat?
30. How can slate be distinguished from shale?

6  
THE PROPERTY  
AUG 24 1942  
OF THE EDUCATION

*★Optional Exercises*

31. Is air a mineral? Explain.
32. We say the earth is made of rocks. Why can we not say the earth is made of minerals?
33. Why is it that a great part of the cores of mountains is made of metamorphic rocks?
34. How does a felsite differ from a porphyry?
35. How can one distinguish felsite from a fine-grained sandstone?
36. Why are the grains of sedimentary rock usually uniform in size?
37. Why are sedimentary rocks often in horizontal layers? Why are they not always horizontal?
38. Why do we consider salt a sedimentary rock? In what ways does salt differ from the ordinary sedimentary rocks?
39. How does the decay of wood differ from the decomposition that forms coal?
40. Explain why metamorphic rocks are usually denser than others.
41. Explain why some metamorphic minerals, like graphite and talc, are smooth.
42. Explain the metamorphism of wood into the various forms of coal.
43. What is the most common surface rock in the United States? Which is the least common?
44. Coarse-grained granites are now on the surface in New England. What does that prove about the elevation of the surface in those localities?

## CHAPTER III

# ECONOMIC IMPORTANCE OF ROCKS AND MINERALS\*

★19. It is worthy of note that from 1900 to 1925 more mineral products were taken out of the earth than during all of previous history. Modern industry depends to a great extent on power and machinery. Power is chiefly dependent on coal and oil, while machinery is practically all iron and other metals. In other words, modern civilization is dependent on our mineral resources, and those nations that are fortunate enough to be rich in mineral resources, particularly coal and iron, are the wealthy nations. Wars are often caused by the desire of one nation to possess itself of natural resources.

The "Great Powers in World Politics" by Simonds and Emeny, recognizes two groups of world powers. (1) Those richly endowed with natural resources. (2) Those that lack sufficient resources. The second group must either accept material inferiority or seek, by conquest, to expand its territory. The first group seeks to maintain the status quo.

The per cent production of some important industrial minerals by the major countries is shown in the following table:

COUNTRY	ALUMI- NUM	COAL	COPPER	IRON	LEAD	PETRO- LEUM	SUL- PHUR	ZINC
Great Britain and possessions	19	18	25	11.5	35	..	..	25
France and pos- sessions.....	10	4	..	12	..	..	..	..
Germany.....	16	21	3	15	5	..	..	9
Italy.....	8	..	..	..	..	..	20	3
Japan.....	..	3	7	3	..	..	6	..
Spain.....	..	..	3.5	..	6.5	..	..	..
U S S R (Russia)	4.25	6.5	3.5	16	..	12	..	..
United States...	26	30	19	26	21	61	71	29

\*This entire chapter is optional.

It will be noticed in the table that the United States ranks very high in mineral resources and if to these be added its agricultural resources, our prosperity is readily understood.

★20. **Coal.** The world's production of coal from 1900 to 1935 is shown in Fig. 17 and the percentage of this total now being

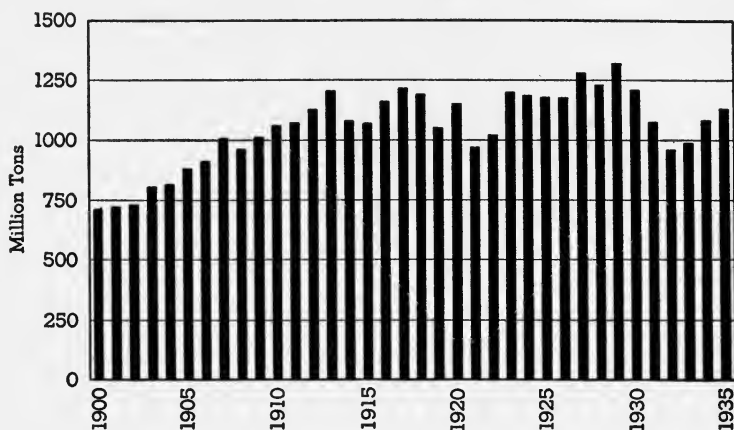

FIG. 17. The World's Production of Coal

produced by the major countries is shown on page 27. The annual value of coal produced in the United States is about one and one half billion dollars. Pennsylvania produces about one third, West Virginia one quarter, Illinois one tenth, and Kentucky one tenth. The estimated coal reserves of the world at the present rate of consumption will last about five thousand years.

Anthracite is rather rare, being found only in Pennsylvania and in Great Britain. The reserves are rather small, and it is estimated that in about one hundred years there will be no more anthracite.

★21. **Petroleum** was first used because kerosene, useful in lamps for illumination, could be extracted from it. The chief product obtained from petroleum today is gasolene for automobile and airplane fuel. Other products include lubricating oils, fuel oil, petroleum jelly, and paraffin.

In this country the annual production is about one billion barrels, worth about one billion dollars. This is about sixty per cent of the total world production, and the estimated reserves in the United States will last less than twenty years.



Other important world producers of oil are Russia, Persia, Venezuela, and Mexico. Germany has recently developed a process of distilling gasoline and other products from bituminous coal and shale, but this gasoline costs much more than that obtained from petroleum.

Texas produces 40% of the total output of the United States, California, 20%, and Oklahoma, 20%.

★22. **Metallic ores.** Of the metallic minerals in the earth's crust, iron makes up about 5% and aluminum 7%, but these are not in the form of metals. The only metals that are found free or *native* are those that are inactive chemically, that do not combine readily with oxygen, water, and carbon dioxide of the earth's atmosphere, and sulphur compounds, found in the depths of the earth. Gold, silver, platinum, and a little copper are found native, while most of the others, including all the useful metals, iron, zinc, lead, aluminum, and most of the copper, are found as compounds. Furthermore, many of these compounds are difficult to work, that is, to extract the metal from them. For example, most of the aluminum of the earth's crust is found in the form of feldspar and clay from which we *can* extract the metal, but only at great cost. Only one compound of aluminum is workable; the mineral *bauxite*. Likewise many minerals like pyrite and hornblende contain iron, but it would not be profitable to extract it from these minerals. On the other hand, it is comparatively easy to extract iron from hematite.

We call *bauxite* an *ore* of aluminum, and hematite, an ore of iron, but clay, feldspar, and hornblende are not called ores.

★23. **Origin of ore bodies.** If we turn back to page 5 where we discussed the nature of the interior of the earth, we shall recall our hypothesis that there is a core of metal at the center of the earth. It is very likely that this consists chiefly of iron, but it is also likely there are other metals in the metallic core. Most of our ore bodies are found in or near a zone of contact between igneous and sedimentary rock; and we believe, therefore, that the metallic compounds were brought from the depths in the molten igneous rock, from which they were diffused into the sedimentary rock by means of hot gases and water under great pressure.

Near the surface, percolating ground waters carrying oxygen and carbon dioxide have usually changed the original ore body

into oxides and carbonates, but deeper down most ores are sulphides. A common way of mining ore bodies is to blast through the rock from the surface until the ore body is penetrated (Fig. 18). This opening is called a shaft, and from the shaft, tunnels may be driven in all directions into the ore body by blasting it out and carrying it to the surface in cars. One of the deepest mines in the world, at Calumet, Michigan, is over a mile deep. It becomes expensive to mine at great depths and it would be impossible to mine at depths of ten miles or more. The deeper we go, the greater the pressure of the overlying rock, and if we get down far enough, the pressure is beyond the breaking point of the rock, so that if a shaft were blasted into the rock, it would collapse and be filled with rock again. There is no known way to solve this problem and we seem confined, for our ore resources, to surface deposits or those less than two miles deep.

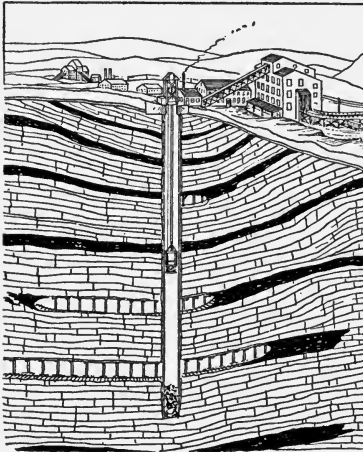

FIG. 18. Cross Section of a Coal Mine

★24. **Iron.** The United States leads in producing more than one quarter of all the world's iron ore. Russia is second, Germany third, Great Britain fourth, and France fifth.

Our production in 1935 was thirty million tons, from which iron worth three hundred sixty million dollars was made. The principal producing states are Minnesota, twenty million tons, Michigan, seven million, and Alabama, three million. There is as yet no sign of exhaustion. The principal ore of iron is hematite. It is dark red in color, but looks black when compact, as in *specular iron ore* (ore with metallic luster). Other ores are magnetite (lodestone) and limonite, a rusty looking mineral.

★25. **Copper.** Copper is used chiefly in electrical transmission because it is a good conductor of electricity. It is also used to make brass, bronze, and other alloys which do not rust.

The United States produces about 20% of the world's copper,

Chile is second with about 17%, Canada about 13%, and Rhodesia about 12%.

In 1935 we produced about seven hundred million pounds of copper, worth sixty million dollars. The chief producing states are Arizona, Montana, Utah, Nevada, and Michigan. Michigan produces native copper in a very pure condition. It is known in the trade as *lake copper*.

The chief ore of copper is chalcopyrite, a complex sulphide of copper and iron. According to estimate, the world's copper ore reserves will be exhausted in about seventy years.

★26. **Zinc.** Zinc is used chiefly to make galvanized iron. The zinc prevents the iron from rusting. Much zinc is also used to make brass, an alloy of copper and zinc. Zinc oxide, an important paint base, is made from zinc.

We produced in the United States in 1935 about one half million tons of zinc worth about forty million dollars.

The principal zinc ore producing states are Oklahoma, Kansas, New Jersey, and Montana, and the reserves are sufficient to last only about twenty years. The chief ore is sphalerite, a sulphide of zinc, called by the miners *rosin jack* or *black jack* because of its luster and color. In the metal market zinc is called *spelter*.

★27. **Lead.** Lead is used chiefly to make white lead, a carbonate of lead, which is the chief paint base. It has a variety of other uses among which are storage batteries, lead pipe, solder, and type metal.

We produce about one fifth of the world's output chiefly in the states of Missouri, Idaho, Utah, and Oklahoma. The chief ore is *galena*, a sulphide of lead which occurs in easily recognized heavy metallic cubes.

★28. **Aluminum.** Aluminum finds its chief use today in the making of alloys combining light weight with strength and resistance to corrosion. These alloys are used very largely in aircraft, automobiles and other vehicles, and innumerable small articles. Cooking utensils of aluminum are light in weight, conduct heat well, and do not tarnish.

As mentioned before, more than seven per cent of the earth's crust is aluminum, and it will at some future time supplant iron; but none of it is native, and most of the compounds are not ores. There is practically only one ore, bauxite, an oxide of aluminum. Practically all of our bauxite is in Arkansas.

During 1935 we produced about one hundred million pounds of aluminum, valued at twenty million dollars.

★29. **Sulphur.** Sulphur is used chiefly to make sulphuric acid, which is necessary in some part of practically every industrial process. Other uses are in making paper, explosives, dyes, and in vulcanizing rubber. Sulphur is usually found around volcanoes, and during an eruption the smell of sulphurous gases is very noticeable.

In Sicily and in Texas and Louisiana the sulphur is found native. In Sicily it occurs in volcanic rock from which it is easily melted out. In Texas it is mined by forcing hot water down to the deposit through a pipe. The melted sulphur mixed with water is forced up through another pipe by air pressure. The sulphur produced in the United States in 1935 was one and one half million tons, worth thirty million dollars. Much of our sulphuric acid is obtained from pyrites or *fool's gold*, a sulphide of iron, and as a by-product of the smelting of copper, lead, and zinc sulphide ores. In each of these smelting operations, the metal cannot be extracted without burning out the sulphur and, since it is illegal to permit the noxious fumes of sulphur to escape into the atmosphere, the smelters are forced to convert it into sulphuric acid.

★30. **Building stones.** In comparatively young countries, like ours, wood is the chief building material; but in older countries, most of the wood has been used up and they have had to look about for more lasting materials. There is nothing so lasting as stone, especially stone taken from a surface outcrop, because, since it has survived exposure to the natural agents of change, air, and water for perhaps millions of years, it will probably last the few score years for which it is needed as a home.

All kinds of rock are used as building stone, but as a general rule, the softer and more porous sedimentary rocks are not so durable as the igneous rocks. If the rock is very porous, as a sandstone is apt to be, it will get soaked with water and in cold weather when the water freezes, the rock will chip off, because the water expands when it changes to ice.

Quartzite, a metamorphosed sandstone, makes a very durable building stone, because it is very compact. In 1935 we used about twenty million dollars' worth of stone for buildings, about fifty

million for roads, etc. In other years we spent about two hundred million dollars for stone.

In quarrying stone, dynamite is used and if there are any joints in the rock these are taken advantage of. Channeling machines are often used before blasting and, in soft stones like slate, wire saws.

The blocks of stone are subsequently cut up by sawing and chiseling and finished by chisels, lathes, rubbing tables, and polishing machines.

★31. **Granite.** This term, in the trade, includes all igneous rocks as well as gneiss. Granites are the most durable building stones but they are much more difficult to quarry and to work. Most of the Egyptian monuments like the Sphinx, and the statues of Egyptian kings and queens are made of granite. At Baalbek, in Asia Minor, the Romans built a temple containing one hundred and fifty granite columns, each seventy feet high and seven feet in diameter. These columns are over two thousand years old, but their surfaces are still smooth and lustrous.

There are many places where granites can be obtained since the chief mass of all continents is granite. But in most places it does not outcrop, that is, it does not appear on the surface, because it is covered by sedimentary rocks. In an old region, however, like the Appalachians, the sedimentary cover has been worn off in many places and reveals the igneous or metamorphic core of the mountains. Granites are quarried in the hilly belt from Maine to Alabama. In the west the chief producing state is California. Traprock (diabase) from New Jersey is used a great deal as crushed stone in building roads. On account of its columnar structure it is easily quarried (Fig. 19).

★32. **Limestone and marble.** Both are forms of calcium carbonate and, as such, they are soft, easily scratched by metal, and slowly dissolved by carbonic acid. For that reason characters engraved on these stones are gradually erased by exposure to air. However, they are not too porous and hence do not chip; and since they are soft stones, they are easy to work up into statues and monuments.

Some of them are streaked with other minerals, pyrite being particularly obnoxious because it rusts badly. Many of the limestones, like the famous Indiana variety, contain fossils which give

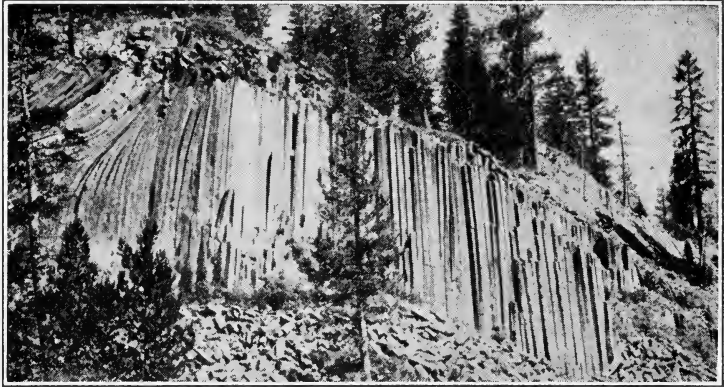

*U. S. G. S.*

FIG. 19. Columnar Structure in Traprock  
Such rock is easily quarried.

the stone a pleasing granular appearance, but at the same time they collect dust and require frequent cleaning.

In the United States, Vermont is the chief source of marble. Indiana produces most of the limestone used in building. Much limestone is used in extracting iron from its ores.

★33. **Sandstones.** These make rather weak building stones; but quartzite, which is often called sandstone, is strong and resistant to weathering.

There are many varieties of sandstone: bluestone, brownstone, flagstone, and freestone. Brownstone from the Connecticut Valley was at one time very popular in New York City, but time has not been very kind to the buildings in which it was used. Flagstone is a clayey sandstone used for sidewalks, because it is thinly bedded and splits into blocks of proper thickness. Freestone is used frequently because it is easily worked.

The famous Berea grit from Ohio is a sandstone much used for fancy work because of the uniformity of its grain. Most whetstones are made of sandstone, because the mineral quartz of which it is composed is harder than steel.

★34. **Slate.** Slate is a metamorphosed shale which has good cleavage, splitting easily into thin, smooth sheets, because of the arrangement of scales of mica parallel to each other. Slate is fairly durable. Its chief use has been for roofing, but of late years

many artificial roofing materials have been developed which are depriving slate of its market.

Most of our slate and sandstone comes from Pennsylvania.

★35. **Clay products.** Bricks, earthenware, porcelain, tile, and some cements are made of clay. The product is decorated after the first baking and before the glaze is applied.

The red color of bricks is due to iron compounds in the clay which, on burning, change to ferric oxide. A pure variety of clay which remains white on burning is called *kaolin*. The value of the clay products of the United States, in 1934, was one hundred and twenty million dollars; in 1927, four hundred million, while cements add another two hundred and fifty million.

Clay is very widely distributed over the earth, since it is a product of the weathering of feldspar, one of the constituents of granite.

★36. **Precious stones.** Gems are minerals which are valued for ornamental purposes because of their color, luster, brilliance, and durability. A piece of glass, for example, might be cut and polished so as to give it considerable brilliance, but it is not durable and therefore has not the value of a diamond or ruby, which are very hard and tough. By the same standard, a diamond with a bad flaw has very little value.

Durability in a gem depends mainly upon its hardness, which is measured by scratching. If a mineral makes a visible scratch on a piece of glass, it is harder than the glass. The standard scale of hardness is:

diamond.....	10	apatite.....	5
ruby.....	9	fluorite.....	4
topaz.....	8	marble.....	3
quartz.....	7	gypsum.....	2
feldspar.....	6	talc.....	1

Diamonds are pure crystalline carbon, the hardest substance in the world. Dark colored, poorly shaped diamonds are called *bortz* and are used for polishing other diamonds. *Carbonadoes* are tough, dark diamonds, used for drilling rock. Diamonds seem to have been formed when an igneous mass under great pressure penetrated a shale or other sedimentary rock containing carbon. It is a metamorphic mineral with a specific gravity of 3.5. At Kimberley,

South Africa, the diamonds occur in volcanic necks or pipes which cut through carboniferous shales.

The chief producing areas are in South Africa and in Brazil. In the United States a few diamonds are found in Arkansas in formations resembling those in South Africa.

*Emerald* is a variety of a mineral called *beryl*, a beryllium aluminum silicate. Its green color is due to chromium. It is harder than glass but seldom without flaws. If without flaws, emeralds are equal to diamonds in value. Brazil and India are the chief sources.

*Ruby* and *sapphire* are both the same mineral, corundum (aluminum oxide). Ruby is red and sapphire is blue; both colors are due to impurities. They are, next to diamond, the hardest substances known. Most sapphires come from Siam, but a few are found in Montana. The best rubies come from Burma, but a few are found in North Carolina.

Rubies are rarer than sapphires and hence more expensive; a large, fine specimen is worth more than a diamond. They are very heavy minerals, even denser than diamond (sp. gr. = 4). Very good rubies are now made artificially. They are in every respect the same as the natural specimens and can be distinguished only by microscopic test.

Rubies must not be confused with garnets, which are not nearly so hard nor so heavy (nor so valuable).

*Topaz* is aluminum fluosilicate. Its color is often yellow, but other colors are frequent. It is as hard as emerald, but not so hard as ruby. It is as dense as diamond (sp. gr. = 3.5) and hence it may be inferred that it is usually found in metamorphic rocks. There is a yellow variety of quartz called false topaz, but this material is light in weight and not so hard as topaz.

The best topazes come from Ceylon and Brazil. In the United States we find some in Maine and Colorado.

*Tourmaline* is a silicate of aluminum and boron, about the same hardness as quartz, but not nearly so heavy as the other gem minerals. It is widely distributed in metamorphic rocks, and it varies in color from brown to black. The red and green varieties are highly prized. The green tourmalines are easily distinguished from emeralds. The tourmalines are very dark green and not so hard as emeralds. The red variety is not so dark as ruby nor so



hard. Brazil, Russia, and Ceylon furnish many good tourmalines. Green tourmalines are found in Maine.

*Turquoise* is a copper aluminum phosphate of waxy luster and bluish green color. It is rather soft, not so hard as quartz, and of no great value. The best variety comes from Persia. In the United States we get turquoise from Arizona and New Mexico.

*Quartz* is silica, a crystalline mineral resembling glass in general appearance. It has a hardness of 7. It is sometimes called *rock crystal* and, when cut, it is known as *rhinestone*. Quartz is common all over the world, but especially good specimens are found in Brazil, Switzerland, and in New York State.

*Amethyst* is blue quartz, *carnelian* is red, and there are other varieties, such as *milky quartz*, *rose quartz*, *bloodstone*, containing red spots in a green background, and *chalcedony*, which has a waxy luster.

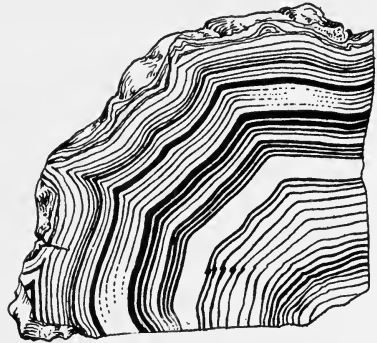

FIG. 20. Agate

*Agate* (Fig. 20) is banded chalcedony, and *onyx* is agate cut in slices which are parallel to the bands.

*False topaz* is yellow quartz, and *chrysoprase* is a green variety, often mistaken for jade.

*Opal* is a variety of quartz, but it is not crystalline. It occurs in all colors and is usually iridescent.

It is often found in silicified wood, which makes it clear that the silica in solution filled the crack or opening and slowly precipitated out in the colloidal condition.

The prettiest specimens, resembling beautiful landscapes, are full of flaws and hence are easily broken. Hungary produces the best opals. In North America, Mexico and Oregon furnish some inferior specimens.

*Jade*. Much of the material sold as jade is chrysoprase, a green variety of quartz. Jade may be either one of two minerals: *jadeite* or *nephrite*, both of them resembling the feldspars. Their hardness varies between 6 and 7, and the specific gravity is about 3.3. The

Chinese make very artistic carvings in jade, which they value above all other gems. The mineral jade, of itself, has no great value. The value of a finished specimen of jade is due to the richness of color, the toughness of the piece, and the artistic nature of the carving. There are many imitations of jade in softer minerals, but these have very little value, because they are easy to make, and do not last long. Jade is found in Burma and China.

### ★Completion Summary

The \_\_\_\_\_ of a nation depends upon its \_\_\_\_\_ resources.

The United States is first in the production of \_\_\_\_\_.

The two states, \_\_\_\_\_ and \_\_\_\_\_ produce more than \_\_\_\_\_ the coal of the United States.

The chief product of \_\_\_\_\_ is gasolene. Nearly half the petroleum comes from \_\_\_\_\_.

Pyrite is not an ore of iron, because \_\_\_\_\_. The chief ore of iron, \_\_\_\_\_, is mined in \_\_\_\_\_.

The chief ore of copper is \_\_\_\_\_.

The chief ore of zinc is \_\_\_\_\_.

The chief ore of lead is \_\_\_\_\_.

Sulphur is mined in \_\_\_\_\_ and in \_\_\_\_\_. It is used in the manufacture of \_\_\_\_\_, \_\_\_\_\_, and \_\_\_\_\_.

Granite is a good building stone, because \_\_\_\_\_.

Marble is \_\_\_\_\_ limestone.

Porcelain and earthenware are made from \_\_\_\_\_.

Precious stones must be durable, \_\_\_\_\_, and \_\_\_\_\_.

### ★Exercises

1. Explain the relation between natural resources and the wealth of a nation.

2. Why is there so little anthracite coal in the world?

3. Which are the chief coal producing states?

4. Name some products of the refining of petroleum.

5. Name three important oil fields in the world.

6. Name three important oil fields in the United States.

7. What two metals make up more than 5% each of the earth's crust?

8. Which metals are found native? Why?

9. What is an ore? How does it differ from a mineral?
10. Explain the probable origin of ore bodies.
11. Name two ores of iron. Where is iron found in the United States?
12. Name one ore of copper. Where is it found?
13. Name one ore of zinc. Where is it found?
14. What is the chief ore of lead? Where is it found?
15. What is the ore of aluminum?
16. Name two important uses of sulphur. What is the source of our sulphur?
17. Name three rocks used as building stone.
18. Why do granite and quartzite make durable building stone?
19. Why does marble take a smoother polish than limestone?
20. Why is most sandstone unsuited for long exposure to weather?
21. What is a whetstone? What is it made of?
22. Of what use is slate in building?
23. What are bricks made of? Name one other product of the same material.
24. What properties should a precious stone have?
25. What is the difference between diamonds, bortz, and carbonadoes?
26. What are the two chief sources of diamonds?
27. In what way do ruby and sapphire differ?
28. Name several gems which are varieties of quartz.
29. In what way does agate differ from ordinary quartz?
30. What is opal?

## CHAPTER IV

### WEATHERING

37. The surface of the earth, as we find it, is covered by loose, unconsolidated material, such as gravel, sand, clay, soil, or earth. The original surface of the earth was everywhere rocky and it has been brought to its present condition by the action of "wind and weather." In physiography this process is called *weathering*. Superficial examination of rocks convinces us that they last forever but more careful examination shows that even rocks change. Rock just taken from the quarry looks quite different from the same rock which has been exposed to weather for a long time. A granite boulder has a dull surface but, if a piece is chipped off, the fresh surface is bright and sparkling.

The chief agents responsible for weathering of rocks are (1) air, (2) water, (3) temperature changes, and (4) plants and animals. The methods by which they cause changes are of two kinds, *mechanical* and *chemical*.

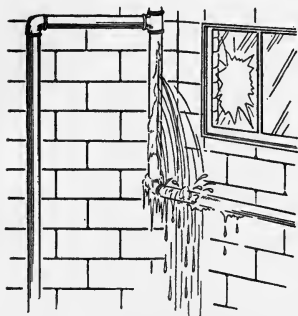

FIG. 21. Iron Pipe Broken by the Expansion of Freezing Water

38. **Frost action.** Most liquids contract in freezing, but water is an exception; it expands, and the force of this expansion is irresistible. When water freezes in iron pipes, the iron is broken by the expansion of the water. Just so, water finds its way into pores, fissures, and joints of rocks and, in winter, as the water freezes, it breaks off pieces of rock.

At the base of every cliff, in humid regions where freezing takes place, we can find accumulations of rough, broken

pieces of rock. This is called *talus*. Igneous and metamorphic rocks are least affected by frost action because they are not highly porous. Sedimentary rocks, particularly sandstone, are most easily attacked because they are very porous. Hence, sandstone used for building purposes in a moist region, where the winters are severe, usually scales off and becomes unsightly.

**39. Weathering due to water and air.** Water alone has practically no effect on rocks. Rock salt and gypsum are soluble in water but such rocks are found only in arid regions. Air alone has no effect on rocks, but air and water together are the chief agents of weathering. Oxygen and carbon dioxide are the gases of the air which, with water, cause important chemical changes in rocks of all kinds.

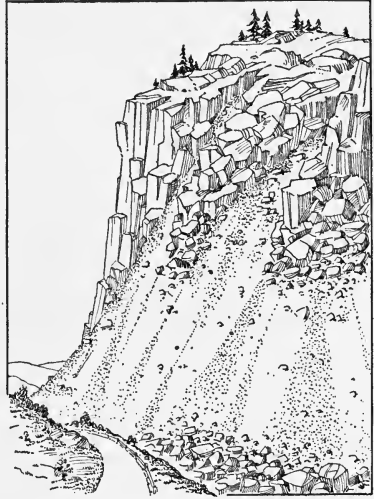

FIG. 22. Talus at the Foot of a Cliff

Oxygen and water attack the iron found as a constituent of many dark colored minerals, changing it to ferric oxide (rust). That accounts for the yellow, brown, or red colors of most rocks and soils.

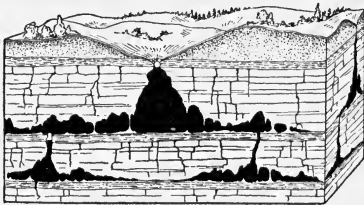

FIG. 23. Caverns in Limestone

Limestone is completely dissolved by water carrying carbon dioxide in solution, although pure water has practically no effect whatever. Dissolved limestone makes

*hard water*. This is carried to the ocean, where animals extract the limestone to build their shells. Limestone in humid

regions is most rapidly eroded, and the solution of great masses of the rock forms caves and other structures.

Most limestones contain some sand or clay and when the limestone is dissolved, the sand or clay remains, unaffected by weathering, as a loose covering or earth. The fertile soils of some limestone regions, as in southern Kentucky, are due to this kind of weathering.

Sandstones whose cementing material is either a calcium compound (limestone) or an iron compound (rust) are rapidly disintegrated by water and carbon dioxide, which dissolve out the calcium or iron compounds and leave a mass of sand. But where the cement is silica, the sandstone is unaffected.

Slate and shale crumble to clay under weathering, but other metamorphic rocks, the gneisses and schists, are as resistant as the igneous rocks.

When granite is weathered, the quartz is unaffected and when the other minerals are removed, the quartz remains as sand. The mica is decomposed very slowly.

★The feldspar,  $KAlSi_3O_8$ , is slowly attacked by water and carbon dioxide; the potassium, K, forms potassium carbonate, which is soluble in water, while the other elements, aluminum, silicon, and oxygen, Al, Si, and O, combine to form clay. The products, then, of the decomposition of granite are potassium carbonate, which helps to fertilize the soil, residual clay, and sand.

As we have seen, the continents were made of granite, and hence the weathering of granite gave us the chief materials which now cover the rocks, clay and sand; and these mixed together are called *earth*. Loose material of any kind which covers the rock is called *rock mantle*. It may consist of boulders, gravel, sand, clay, silt, earth, or soil.

**40. Effect of temperature changes. Exfoliation.** In arid regions, frost action plays no part in weathering, but in those regions the clear atmosphere permits great variation in temperature. During the day the heat of the sun easily penetrates the air and bakes the surface of the rock. Since

most rocks are very poor conductors of heat, only a thin surface skin is baked and expanded. At night, radiation is rapid, because of the clear air, and the rocks cool rapidly. The alternate expansion and contraction splits off pieces of the rock, like the skin of an onion. This process is called *exfoliation*.

Exfoliation occurs also in humid regions where it cannot be accounted for in this way. Some geologists explain the splitting off of shells as due to chemical changes, chiefly absorption of water (hydration) with a consequent increase of volume which causes pressure.

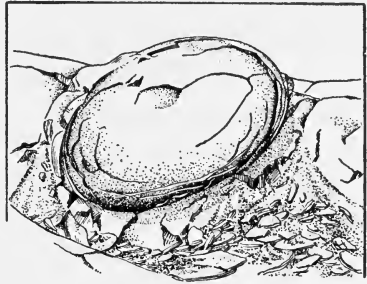

FIG. 24. Exfoliation of a Boulder

Sedimentary rocks under the direct heat of the sun are sometimes found to buckle and break, like cement sidewalks in summer.



FIG. 25. What split the rock?

**41. Weathering due to plants and animals.** Plant roots find their way into openings in rocks and enlarge them. The roots of a tree are often found growing in a rock crevice. In this way as the roots increase in size they split the rock. Animals that burrow in the earth, like ants and worms, increase the extent of surfaces exposed to weathering and therefore hasten the process.

Man assists weathering by clearing the forests and removing the vegetable covering of the soil. This exposes new surfaces to wind and water.

All these processes of plants and animals are mechanical, but plants also help in chemical weathering. Decaying plant material in the soil, called *humus*, is a source of the carbonic acid and the other acids which attack the underlying rock.

The carbonaceous material of plants also causes a change in the color of the soil. The red color is due to oxidized iron (rust) produced by the chemical weathering of some rocks. There are two classes of iron compounds, *ferrous* and *ferric*. The latter are red, yellow, or brown in color. The ferrous compounds are almost colorless. Hence the reduction of ferric to ferrous compounds by the carbonaceous material of the humus results in a change from red soils to colorless and finally to black.

### Completion Summary

The action of natural agents on rocks is called \_\_\_\_\_.

Weathering is of \_\_\_\_\_ kinds: \_\_\_\_\_.

Talus is formed chiefly by \_\_\_\_\_.

\_\_\_\_\_ and \_\_\_\_\_ of the air cause chemical \_\_\_\_\_ in rocks.

Some of the compounds formed are soluble in water and are removed in that way. The other constituents of the rock then \_\_\_\_\_, forming residual rock mantle.

\_\_\_\_\_ is one rock which is completely soluble in water and carbon dioxide.

The cementing material of sandstone is often \_\_\_\_\_. In weathering, this is \_\_\_\_\_, and the material that remains \_\_\_\_\_.

\_\_\_\_\_ and \_\_\_\_\_ are the chief products of the weathering of granite. Granite, therefore, \_\_\_\_\_ soil.

Exfoliation \_\_\_\_\_ arid regions.

Plants and animals \_\_\_\_\_ weathering; the plants \_\_\_\_\_, and the animals \_\_\_\_\_.

Soils are often red because \_\_\_\_\_.



*Exercises*

1. Why do we have the impression that rocks last forever?
2. What are the agents of weathering?
3. Explain the effects of frost action.
4. What is talus?
5. What kind of rock is most easily attacked by frost action?
6. In what rock is solution the most important factor in weathering?
7. How is sandstone affected by weathering?
8. How does weathering attack metamorphic rocks?
9. Why is quartz always a product of the weathering of granite?
10. What are the chief constituents of rock mantle?
11. How does rock mantle differ from earth?
12. What are the chief constituents of earth? Why?
13. What is exfoliation? Where is it an important factor in weathering?
14. What part is played by plants in weathering?
15. What part is played by animals in weathering?
16. Why are soils often brown?

*★Optional Exercises*

17. What part is played by solution in the weathering of igneous rocks?
18. Explain in detail the chemical effects of weathering on granite and show how this process produces the chief constituents of fertile soil.
19. Why do we find deposits of pure clay or almost pure sand in some places, since both are produced together?
20. Explain the changes in the color of soils.

## CHAPTER V

### ROCK MANTLE AND ITS MOVEMENTS; SOIL AND SOIL EROSION

**42. Residual mantle.** The process of weathering breaks down the surface rocks mechanically and chemically into a loose material which *mantles* or covers the rocks. This loose material, including boulders, gravel, sand, clay, earth, soil, etc., is called *rock mantle*. In some places the mantle is still in the position where it was formed and some of the boulders will be found to have the same composition as the underlying bedrock. These are called *residual boulders* and the entire covering is called *residual mantle*.

**43. Movements of the rock mantle.** In time the mantle is removed, transported, and deposited somewhere else, usually at a lower level. The entire process of wearing down the rock and carrying it away is called *erosion*.

The agents responsible for the removal of rock mantle are (1) gravity, (2) wind, (3) streams, (4) the sea, and (5) glaciers.

**44. Movements due to gravity.** When pieces of rock are loosened on a steep slope they fall and slide down until they reach a supporting mass of talus below. This mass comes to rest at its *angle of repose*, which will be steeper for coarser fragments. But any additional force, like the wind, an earthquake, or the falling of a new boulder, may start the delicately balanced mass moving again. This is a *landslide*. A heavy rain soaking through a mass of loose material on a steep slope may initiate a landslide. It is dangerous for a mountain climber to ascend across the talus when it is on a steep slope, because he may loosen one boulder which will start an avalanche.

Sometimes the entire mantle moves slowly down the slope, together with its covering of vegetation. This is called *creep*. It is assisted by frost action, since, in freezing, the expansion lifts some of the loose fragments and, when the thaw takes place, they creep down the slope.

In some cases the mass of boulders is so great and the slope so steep that the entire talus creeps. In this case it is called a *rock glacier*.

**45. Wind erosion.** By itself the wind has little if any effect on solid rock; but when it picks up and carries along



FIG. 26. Wind Abrasion in an Arid Region

dust, sand, and even gravel, it uses these tools, like a file or a sand blast, to wear away hard rocks. This is called *wind abrasion*. In arid regions the telegraph poles are sometimes cut down by the abrasion of wind-blown sand. In humid regions this process is a negligible factor, except on the seashore, since the loose material is protected by a layer of vegetation; but in arid regions wind abrasion is the chief agent of erosion. It polishes hard rocks to a smooth surface; it wears away the softer parts of rocks like granite, thus causing the rest of the mass to crumble into gravel and sand. In the intermediate stages of this process of abrasion, strange and weird forms are developed, especially in rocks as soft as limestone.

**46. Sand dunes.** Wind action is very noticeable in dry regions, like deserts, where the air is frequently full of dust

and sand. Even on the seashore, in humid regions, the sand is blown about when it is thoroughly dry. On the desert, these sand storms often overwhelm travelers. The enormous quantities of sand transported in this way are deposited in places where an obstruction, like a rock, a tree, or a house,

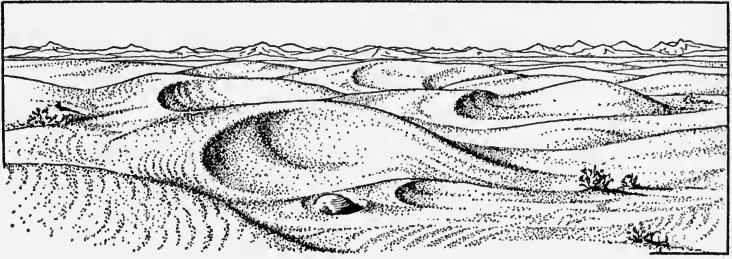

FIG. 27. Sand Dunes

breaks the force of the wind. Houses, forests, and even cities have been buried in sand in this way. The sandy deposit is called a *dune*. Dunes are roughly oval in shape. Many of them are 100 feet high and there are some in Africa as much as 400 feet high.

Inspection of a dune reveals the direction from which the prevailing winds blew, since on the leeward side of the dune

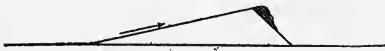

FIG. 28. Diagram of a Sand Dune

Arrow shows wind direction.

the sand assumes its angle of repose which is about  $25^\circ$ , whereas on the windward side the slope is gentle.

Along the shore of the sea or a large lake, dunes are developed by the winds that blow from the water to the land. These dunes are deposited at about the same distance from the shore all along, so that on the map they appear in a line paralleling the shore. See Fig. 29.

Dunes are not stationary in shape or position; the sand that is deposited may be picked up by the very next wind and carried farther away. In this way the entire dune frequently moves about 20 feet a year or even as much as

100 feet a year, as on the west coast of France. This migration of dunes may be prevented in humid regions by covering the windward side, or sometimes the entire dune, by a protective layer of vegetation. In arid regions this cannot be done.

**47. Dust storms.** Dust is more easily carried than sand. Much of the fine surface material from the Great Plains is carried far across the Mississippi. Dust from the Gobi desert is carried across the mountains into China. Volcanic ash, or dust thrown high into the air, is carried far out to sea and sometimes far around the earth. In the great eruption of Krakatoa in 1883, the dust was carried around the earth several times. Dust from the Sahara is found on the decks of ships in the Mediterranean and sometimes even in the countries of southern Europe.

Dry farming in our semiarid Great Plains has removed much of the vegetation which originally covered the soil and has left it almost bare. Every puff of wind now picks up the dry soil and carries it away. H. H. Bennett, of the Soil Conservation Service, says, "On the 11th day of May 1934, the sun was blotted out over a vast area of Northwestern United States by a huge dust storm that originated in the drought stricken wheat and sorghum fields, west of the Mississippi." The effect was disastrous in the region covered by the

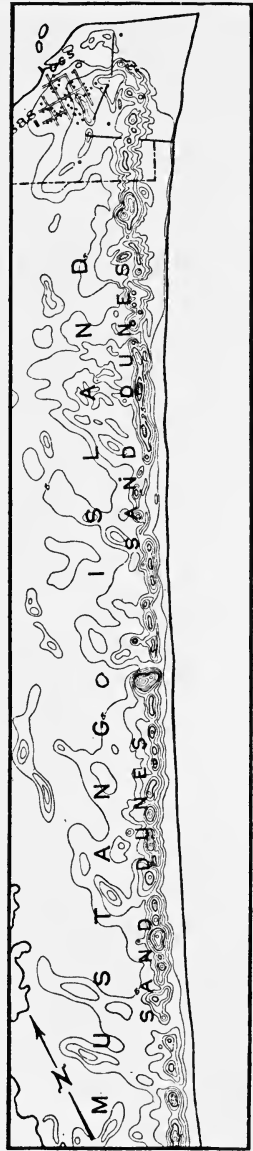

FIG. 29. Sand Dunes near the Shore

dust. Roads were blocked, vegetation ruined, and the life of the entire region was at a standstill. The subject of soil erosion resulting from this and other forces will be taken up in another paragraph.

**48. Loess.** Deposits of fine wind-blown material are called *loess*. When this is deposited in a humid region it makes very fertile soil, because it contains grains of feldspar which has not been acted upon by water (coming as it does from an arid region). Feldspar is rich in the element potassium, an essential for plant growth.

Loess stands up in steep cliffs, in spite of its loose texture. There is a certain amount of clay in the loess and this, no doubt, acts to hold the rest of the loose particles together.

There are enormous deposits of loess in China, where many of the inhabitants live in holes dug in the soft mass. Here also some of the roads have worn deep canyons through the loess. The Yellow River probably owes its name to the loess which is carried down by its tributaries. There are also extensive loess deposits in central Europe and in the Mississippi Valley. In southern Nebraska and western Iowa the loess reaches a thickness of 100 feet. At Council Bluffs, Iowa, we find a characteristic exposure of loess which has been eroded into steep-walled cliffs.

**49. Movement of the rock mantle due to wave action.** Wave action affects the bottom only in very shallow water and here the loose material is dragged along toward the shore and sometimes hurled by the breakers on the shore itself. As the water returns, the undertow carries the fine material back although it may not be able to carry the coarser matter dumped on the shore by the breakers. Since most waves are driven against the shore at an angle, they cause a slow movement of rock mantle parallel to the coast.

**50. Transportation of rock mantle by glaciers.** The accumulated snow on a slope ultimately becomes consolidated into ice and as its weight increases it begins to slide. A moving mass of ice and snow is called a *glacier*. Sometimes

it crashes down a mountain in an avalanche, but usually it moves very slowly, a few feet a day.

Glaciers transport rock mantle in several ways. Some is swept along in front, some is imbedded in the ice and dragged along, and some loose boulders fall on the top of the ice from overhanging cliffs and are carried along.

Some of the mantle transported by a glacier is dropped along its path, some is pushed to the sides, and the rest of

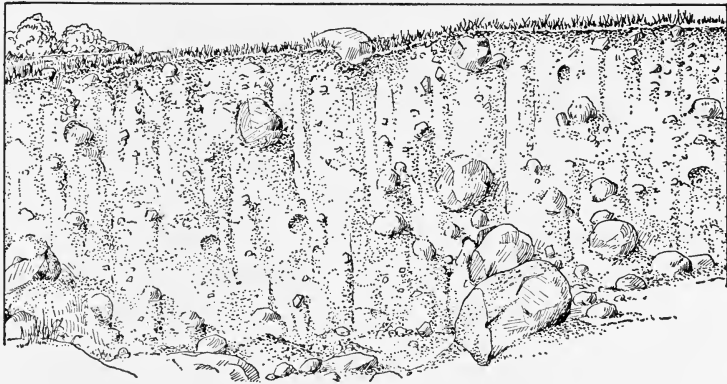

FIG. 30. Glacial Till

it is deposited where the glacier melts, as an unsorted mixture of boulders, sand, and clay, called *glacial till* or *drift*, several feet thick, sometimes almost 100 feet thick (Fig. 30). This material is then reworked by the other agents of erosion, principally water. Most of the soils of northern United States and Europe owe their origin to this process. (See Glaciers, Chapter IX, for details.)

**51. Transportation by streams.** Streams lift up and carry fine material, like mud or sand, and push coarser matter along the bottom. With increased velocity, the carrying capacity increases until the water is capable of moving huge boulders by rolling them over and over. When the slope is greater, the water is able to move larger boulders which are deposited at the foot of the slope.

. In semiarid regions, when it rains, the water rushes down the hills, carrying a mass of rock mantle, but when a level spot is reached the water is suddenly arrested in its progress and the mass of miscellaneous debris is dropped. Since the water comes out of a narrow defile in the hills and spreads out on the more level ground, the deposit takes the shape of a fan. Such deposits are called *alluvial fans* (Fig. 31).

In humid regions, where the water flows continuously, the load carried by the streams is sorted out as it is deposited:

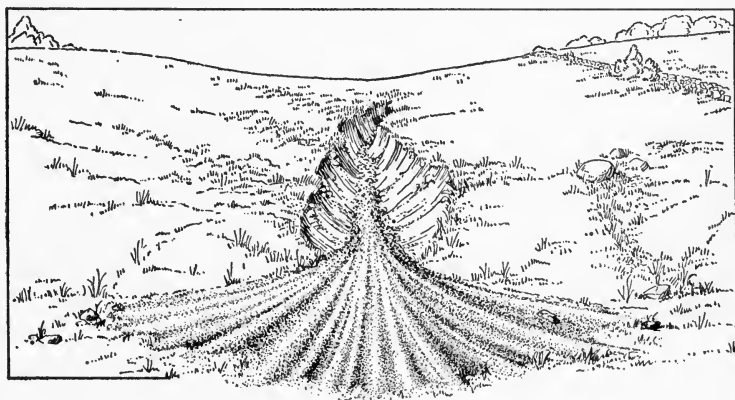

FIG. 31. Small Alluvial Fan

here a mass of boulders, there gravel, somewhere else sand, and in other places mud. When the stream enters a large body of water, at its mouth its velocity is suddenly reduced and it must therefore drop the rest of its load, which usually consists of very fine matter like clay.

When the stream is in flood, it overflows its banks and spreads over the surrounding lowlands. Here also its velocity is reduced and consequently deposition of mud occurs.

The debris deposited by streams is called *alluvium*.

**52. Soil.** We have seen that the bedrock of the earth is covered by a layer of loose material called rock mantle, which in some places is an unsorted mixture of coarse and fine matter, in others carefully graded and sorted, here coarse



and there fine. Any of this rock mantle in which plants will grow is called *soil*. Some of the soil was formed by the weathering of the bedrock on which it rests. This is called *residual soil*. But in most cases soils have been transported and therefore they vary very much in texture and composition.

Texture depends on the size of particles, which varies from large to small as follows:

1. Boulders are very large — about six inches or more in diameter.
2. Gravel has pieces smaller than boulders: down to about  $\frac{1}{8}$  inch.
3. Sand particles are smaller than gravel but not so small that the wet mass will hold together.
4. Very fine particles, which the wind can pick up, are dust. When wet, it sticks together and is called *silt*, if it contains fine quartz particles; but if it contains almost no quartz it is called clay.

We find boulders of all kinds of rocks. Gravel and sand usually consist of quartz, probably because many rocks contain quartz, and when the rocks are mechanically weathered, the constituent minerals are either attacked chemically or are quickly worn because they are not hard. But quartz is not chemically changed by weathering nor is it easily worn because of its hardness.

Clay is not chemically attacked either. Hence the mineral soils consist principally of mixtures of two minerals, clay and quartz. Besides these, all soils also contain organic matter, the product of the decay of leaves and roots, called *humus*.

Each constituent of soil serves some useful purpose in cultivation. The sand acts as the body or bulk of the soil, permitting the plant to penetrate and attach itself so that it can hold its leaves up in the sunlight; but a soil composed entirely of sand has no cohesion and permits every wind to

displace the roots of the plant and often to uproot it altogether.

Furthermore, water and soluble mineral compounds are held by the surfaces of the particles of soil. The smaller the particles, the greater will be the total surface, and the greater the total quantity of water which can wet the surface. For example, one centimeter cube of rock has a total surface of 6 square centimeters, but if it were broken down into coarse sand with a diameter of 0.1 centimeter, there would be one thousand particles with a total area of 60 square centimeters. The result of further subdivision is shown in the following table:

ENORMOUS DEVELOPMENT OF SURFACE BY SUBDIVISION OF ROCK  
INTO SMALL PARTICLES

SUBSTANCE	DIAMETER OF PARTICLE	NUMBER OF PARTICLES	TOTAL SURFACE
1 cm. <sup>3</sup> of rock	1 cm.	1	6 cm. <sup>2</sup>
Coarse sand	0.1 cm.	1000	60 cm. <sup>2</sup>
Silt	0.001 cm.	1 billion	6000 cm. <sup>2</sup>
Clay	0.000001 cm.	1 billion billion	6,000,000 cm. <sup>2</sup>

A consideration of the above table will show how much more effective clay is for retaining water as well as dissolved mineral matter. Clay is, therefore, essential for a good soil, since it furnishes feeding areas for the root hairs. In very fine soils, water may be drawn upward a distance of several feet by *capillary action*.

Clay has plasticity and holds the sand together, but it is difficult to penetrate, and hence both clay and sand are essential for good soils. Too high a clay content causes the soil to hold too much water, which may drive out all the air. Soil which has no air cannot successfully be cultivated.

Besides the mineral content, a fertile soil requires a certain amount of organic matter derived from plants: leaves, roots, fruits, and other plant tissues. These are decomposed by microorganisms until the original plant structure is un-

recognizable and nothing but a jelly-like or colloidal mass remains. This is called *humus*. It furnishes to the growing plants soluble nitrogen, potassium, and phosphorus compounds, in which the soil is otherwise deficient. The humic acids produced by decomposition attack the minerals of the soil chemically, causing them to yield up other elements which are needed by the plant. Humus keeps the soil in colloidal condition, during which it holds water in the proper proportion to air. The water held by the colloidal soil dissolves mineral substances which would otherwise be washed out by rain. Such soil, therefore, has the proper consistency for cultivation. Soil very rich in humus is called *muck*.

★Many soils have a red color due to oxidized iron compounds taken from minerals in the rocks. The red color indicates that the soil has little, if any, humus. The organic compounds of the humus reduce the oxidized ferric compounds, which are highly colored (red, yellow, or brown), to ferrous compounds which have practically no color. Besides, the ferrous compounds are more soluble and are carried away by water containing a little acid, like carbonic acid or any organic acid derived from the humus. For these reasons the red colors fade to grays and finally to black, which is the color of the carbon, some of which is formed from the partial decay of plants.

Red soils are called *laterites* (from the Latin word *later*, a brick). They have very little fertility because they are deficient in humus.

**53. Classification of soils.** For agricultural purposes, soils may be divided into three classes: mineral, calcareous, and organic. Calcareous soils consist chiefly of chalk, and organic soils are chiefly peat with little mineral matter. Most of our soils are mineral soils, and we shall discuss only these.

**54. Mineral soils.** There are three groups of mineral soils: sands, loams, and clays, but these grade into one another imperceptibly, so that we have sandy loams and clay loams of infinite variety. But all of them contain sand, silt, and clay, as can be seen from the following table show-

ing the approximate composition of one sample of each of four kinds of soil.

	SAND	SILT	CLAY
1. Ordinary sand.....	85%	10%	5%
2. Sandy loam.....	60%	30%	10%
3. Clay loam.....	50%	30%	20%
4. Clay.....	10%	35%	55%

Sandy soils are loose, easily penetrated by plant roots, and well supplied with air; but the water runs through rather too easily. They are easy to work and are used in gardens and nurseries.

Loams are not so loose but permit easy penetration by roots and water. The water is held better by loams; hence they are used for all kinds of plants. Clays are difficult to cultivate, hold water too well (to the exclusion of air), and cannot easily be penetrated by roots. When they have sufficient lime and organic matter they lend themselves to the growth of wheat.

### SOIL EROSION

**55. The threat to agriculture.** In its natural state the soil is adequately protected against the destructive effects of wind and running water by the vegetable cover — grass and trees — but when this is stripped off in order to cultivate the soil, every puff of wind carries off some of the fine topsoil when it is dry, and every rain washes some of it away, especially on steep slopes. More than 80% of the agricultural land area of the United States has a slope greater than  $\frac{1}{2}\%$  (a fall of half a foot per 100 feet), which is steep enough to be subject to soil erosion.

Three billion tons of soil a year are being washed into the ocean and this is only a part of the total soil removed. Much more is transported and dropped over rich soils, which are thereby often damaged. Much of the sediment is deposited in reservoirs, irrigation ditches, and harbors, which are thereby silted up. The irrigation systems of the West may soon become useless because of this filling of the storage basins.

Already 100 million acres of agricultural lands have been ruined, and the process is going on at the rate of one half million acres per year. Within 100 years, we shall have only 150 million acres of farm lands left and it has been estimated that this cannot feed our population.

A survey of the corn lands shows that in spite of improved knowledge and use of fertilizers, the average yield has dropped from 27 bushels per acre (1870–1880) to 26 bushels per acre (1920–1930); and we can readily understand that this is the result of the removal of 50 million tons per year of the three principal elements, potassium, nitrogen, and phosphorus, when only one half million tons are returned in the form of artificial fertilizers.

The formation of soil is a slow process, requiring thousands of years. Its removal therefore constitutes for us an irreparable loss.

**56. Causes of soil erosion.** The normal geological processes of erosion are very slow and they cannot be arrested by man, but when man removes the soil cover — trees and grass — by clearing, burning, and excessive grazing, and loosens the soil by cultivation, resistance to the forces of erosion is very much lessened and these forces become excessively destructive.

In an experiment conducted by the Soil Conservation Service at Bethany, Missouri, it was found that the loss of soil and water was much greater from land growing corn than from grass-covered soil; and this was accentuated when the slope was increased. These results are shown in the following table:

SLOPE	SOIL LOSS IN TONS PER ACRE		WATER LOSS IN % OF TOTAL PRECIPITATION	
	CORN	GRASS	CORN	GRASS
8	60	0.3	30	13
4	20	0.3	27	8

Apparently, the grass cover was very effective in preventing soil erosion and loss of water. It is noticeable that the soil loss was the same on both slopes under grass.

The chief forces in soil erosion are the wind and running water, and these produce three types of erosion.

1. Sheet wash
2. Gullying
3. Wind erosion

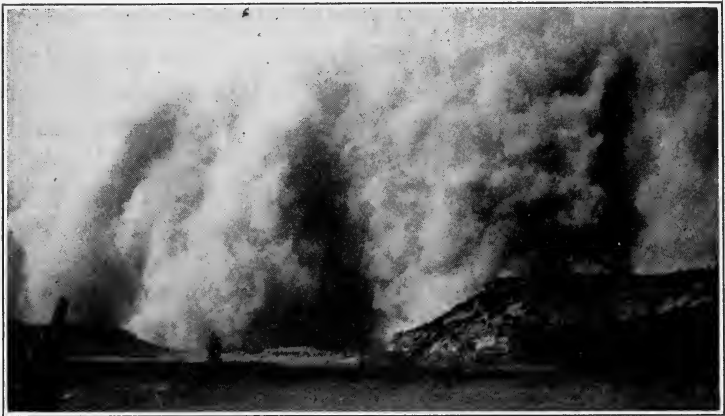

*U. S. Department of Agriculture*

FIG. 32. A Dust Storm

**57. Soil erosion due to wind action. Dust storms.** Wind erosion has already been taken up in paragraph 45. It will be remembered that when cultivated land dries up, as it does under the hot sun, the wind can pick up and blow away not only fine dust, but even sand. The wind is the principal agent of soil erosion in arid and semiarid regions, like our Great Plains, while sheet wash and gullying are responsible for most of the destruction in humid regions.

In the area from Texas to North Dakota, wind erosion has ruined about 4 million acres and has seriously affected about 60 million more. In 1934, a disastrous dust storm, caused by prolonged drought, removed several inches of the

topsoil from much of this region and spread it out over the country to the east, some of it being carried into the Atlantic Ocean.

A passenger on a train in Kansas describes one of these dust storms as follows: "I had read of dust storms, but they were vague in my consciousness. Now I see one, and it is a terrible, an awesome thing. They are clouds of dust-soil; soil blowing away from a ravaged and denuded land.

I have had only one thought in my brain, as I sit on the train and look out at this desert through which we have been passing for two hours. It is a saddening, almost a heart-tearing thought. It is the thought that right here, under my very eyes, I am seeing this country blowing away. Here, in what was once the richest farm and stock land of the Middle West, I see the destruction of that soil which has fed us.

I see death, for there is no life; for miles upon miles, I have seen no life, no human beings, no birds, no animals. Only dull-brown land, with cracks showing; ground that looks like clay. Hills furrowed with eroded gullies. You have seen pictures like that in the ruins of lost civilizations.

Trees once in a while. But their branches, their naked limbs are gray with dust. They look like ghosts of trees, shackled and strangled by this serpent, flinging their naked arms skyward, as if crying for rescue from this encircling, choking thing."

**58. Sheet wash.** When rain falls on the ground, some of it sinks through the surface and some runs off. This surface runoff is at first a sheet but soon it breaks up into tiny streams of muddy water. Every drop of water that fell on the soil has loosened some fine silt, picked it up, and is carrying it along. This process is called *sheet wash*.

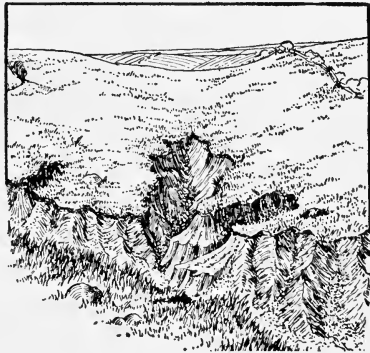

FIG. 33. Gullies

**59. Gullying.** When the runoff finds a depression it takes

that path and if the slope is sufficient, rapid headward erosion sets in. A gully may be started by a natural depression or by an artificial one. Running a wagon or dragging a plow down a slope may be the beginning of a destructive gully.

When the gully cuts down below the water table it drains a much larger area, and the increased velocity and larger volume of the water still further accentuate the soil erosion. The gully will develop branches which ultimately cover the entire area.

**60. Soil erosion and flood control.** Not only is the soil being lost from much of the cultivated upland, but the stream channels are being silted up. The water runs off the uplands much more rapidly for two reasons:

1. Cultivated soil does not hold water so well as soil covered with grass and forest litter.

2. Where the soil has been removed, the runoff is complete.

When this excessive runoff reaches the silted-up streams it overflows the banks and we have a flood. It seems apparent, therefore, that one important factor in any system of flood control must be a proper method of cultivation, since soil conservation will check rapid runoff.

**61. How to control erosion.** The Soil Conservation Service of the United States studies soil erosion, finds remedies and preventives, and educates the public in the use of conservation methods. They recommend the following for the control of soil erosion:

1. Take out of cultivation all steep areas whose slope is greater than 15% and cover them with trees or grass.

2. Protect the cultivated land by strip-cropping; that is, grow clean tilled crops, which lay bare the soil, like corn, tobacco, and cotton, between parallel bands of grass and other untilled crops, planted along contours.

3. Terracing, to stop erosion of water.

4. Plow down stubble, instead of burning it, to protect against wind.



### Completion Summary

Rock mantle is the result of ———. It is called residual soil when ———, and transported soil ———.



FIG. 34. Strip-cropping

Movements of loose mantle are brought about by ———, ———, ———, ———, and ———.

——— is chiefly effective in arid regions.

Dunes are ——— sand ——— migrate ———. Dust is carried ——— sand.

Loess is ———. Loess, dunes, and dust storms are frequent in the interior regions of the great continents, because ———.

Alluvial deposits are made by ———.

Soil supports ———. It consists chiefly of ———.

Soil erosion is brought about chiefly by cultivation, because ———. It can be prevented by ———.

### Exercises

1. What are the chief constituents of residual mantle?
2. Name the factors in the transportation of rock mantle.
3. Describe creep.
4. In what kind of region is wind action an important factor in erosion?
5. Why are sand dunes not often seen in humid regions? Why do we sometimes find sand dunes on the shore?
6. In what kind of region are dust storms common? Why?

7. What is loess? Why is it fertile?
8. Explain how waves move rock mantle.
9. What is glacial drift?
10. What is an alluvial deposit?
11. What is soil? How does it differ from earth?
12. How does a residual soil differ from a transported soil?
13. What is the function of sand in soils?
14. What are the advantages and disadvantages of clay in soils?
15. Why is clay an essential constituent of fertile soil?
16. Make a tabular form showing the essential constituents of soil, together with the function of each constituent in cultivation.
17. What advantage would there be in a soil which was very rich in sand?
18. What advantage would there be in a soil very rich in clay?
19. What does humus furnish to the growing plant?
20. What is loam?
21. What is meant by soil erosion?
22. What are the chief agents of soil erosion?
23. In what way does the cultivation of the soil for corn lay it open to erosion?
24. Explain the relation between wind action, soil erosion, and dust storms.
25. What is sheet wash?
26. How does gullyng hurt farm land?
27. Explain how a gully starts.

#### ★*Optional Exercises*

28. Explain how sand dunes are built up parallel to a shore.
29. Why is the material in an alluvial fan rather heterogeneous, whereas that on the banks of a stream is assorted?
30. Draw a diagram showing a hill on which is a stream flowing down to a plain. Show in the diagram where the following would be deposited: boulders, gravel, sand, silt, clay.
31. Explain the change in the color of soils from red to black, introducing as much of the chemistry of the changes as you can.
32. Explain how dry farming is in great part responsible for the dust storms of the Great Plains.
33. How can gullyng be prevented or remedied?

## CHAPTER VI

### RUNNING WATER

**62. Rainfall.** Rain owes its origin to evaporation, chiefly from the surface of the sea, and to precipitation due to causes which will be discussed later. The amount of rainfall varies from two inches per year in Death Valley to five hundred inches per year in parts of India. In this respect we classify the regions of the United States as follows:

Annual rainfall over 20 in.	Humid region
Annual rainfall, 10–20 in.	Semiarid region
Annual rainfall less than 10 in.	Arid

The rain which falls on the land may be disposed of in four ways:

1. Part evaporates.
2. Some collects in ponds.
3. Some sinks into the ground.
4. The rest runs over the surface to a river. Of that which sinks into the ground, a part finds its way, at lower levels, into the streams and adds to the volume of running water.

**63. How running water moves rock mantle.** Water has two ways of eroding rock: solution and abrasion. It is an old saying that “water will wear away stone,” but pure water, by itself, has little, if any, effect on rocks. Carbonic acid, added to the water as it sinks through decaying vegetation, enables it slowly to attack minerals containing calcium, magnesium, and iron, and to remove these substances in solution. Limestone is the most common mineral subject to this solvent action. Many sandstones, consisting of grains held together by a cement of calcium or iron carbonate, are disintegrated by solution.

It has been estimated that about three billion tons of rock in solution are carried to the sea every year. These dissolved compounds include calcium and magnesium bicarbonates and sulphates, sodium chloride (common salt), and silica.

The process of weathering prepares the rocks for removal by breaking them into smaller pieces which the water can move mechanically. About ten billion tons of sediment are carried by streams and deposited in the sea every year.

The size of particles which can be moved by running water depends on the velocity of the water. A few examples are shown below:

VELOCITY OF WATER	SIZE OF PARTICLES CARRIED
0.2 mile per hr.	Clay
0.5 mile per hr.	Sand
1.0 mile per hr.	Small pebbles
2.0 miles per hr.	Two-inch pebbles
5.0 miles per hr.	Small boulders

When the velocity is doubled, the water can move particles sixty-four times as large! We need no longer be surprised when we see the huge boulders, some of them weighing many tons, which have been moved by running water.

Of course the water does not actually lift the boulder off the bottom, but rolls it along. Lighter masses are picked up and thrown forward in little leaps, while the very fine material remains suspended during the entire course of the river, and settles only when the water comes to rest. In this connection, we must not forget the buoyant effect of water, which makes it appear that rocks lose weight when they are submerged (Archimedes's Principle).

The amount of material carried by running water depends not only upon its velocity but also upon the kind of rock it flows over. Muddy streams usually flow through regions made of shale and other soft sedimentary rocks, whereas streams that are clear flow over metamorphic and igneous rocks.

**64. How a river erodes.** The material carried by water furnishes the tools with which the river can wear away rock and cut a deeper and deeper channel. A moving body of water carrying its load is therefore like a sinuous file, and, in the process, the material hurled against the rock is itself worn ever finer and finer.

A river rises on high ground and ultimately finds its way to the sea. At its source the water flows rapidly because of the steep slope or *gradient*; but this gradient flattens out as the river proceeds on its course and at its mouth the slope may be practically nothing. Where the gradient is steep, the stream cuts rapidly into its bed, deepening its channel and by that very process reducing its gradient.

While the gradient is steep, the water pushes obstacles out of its path or flows over them, maintaining a generally straight course; but as the gradient is reduced it cannot push obstacles away or flow over them: instead, the water is forced to move aside and therefore it begins sidewise cutting. The stream has now developed from *youth* to *maturity*. It begins to widen its channel, cutting into its bed more slowly than during youth.

There comes a time in the life history of a stream when the gradient has been so reduced that the stream is at the level of the body of water into which it empties. It has now reached *base-level*. It cannot cut any lower, for the water will not flow. This is *old age*.

It must be remembered that, during most of its life history, a stream shows all stages of development in different parts. At its source, in the hills, it is youthful; at its mouth, where it enters a lake or sea, it is old; while in the rest of its course it is mature.

One often hears the statement, "A river wears down the mountains," and may be unable to understand how the water in a river can wear down mountains it does not touch. The Colorado River, for example, will ultimately erode the entire mountain system through which it has cut

its gorge. It must not be forgotten that every drop of water that flows into the Colorado has fallen on higher ground and run down into the river below, eroding as it flows. *All these little tributaries are part of the Colorado River*, and it is they that wear down the mountains; the parent stream merely removes the waste.

A river formed on a surface of uniform hardness develops a pattern like that of a branching tree; hence the term, *dendritic drainage* (Fig. 35).



FIG. 35. Map Showing Dendritic Drainage

**65. Deposition by running water.** Whenever the velocity of the water is decreased, it can no longer carry the coarser material and this is dropped. The simplest case of this kind occurs in semi-arid regions where streams are intermittent because of insufficient rainfall. When it rains the water runs rapidly

down the slopes, since the surface is usually bare rock. As the water comes out on the more level ground at the foot of the hill, it spreads out, its velocity is suddenly checked, and it drops its entire load. The larger pieces are dropped right in its path as it emerges from the ravine and tend to choke up the outlet; but the next rush of water sweeps them away or overrides them. In this way the debris is piled up helter-skelter, large and small pieces in a confused heap, but with the coarser material nearer the ravine and the finer material on the valley floor, where for a short while the water spreads out like a lake. The shape of this deposit is roughly like a fan with the handle at the ravine; hence it is called an *alluvial fan*, Fig. 31.

Similar alluvial fans are formed where a swift tributary

emerges on a level valley or enters the parent stream, but these deposits in water are commonly finer material and are easily removed, so that alluvial fans are commonly features of arid regions.

**66. Deposition in rivers.** When a river changes its slope it must drop the coarser particles, and each time its velocity is checked, from any cause, some of the load will be dropped. Each deposit will contain particles of about the same size as shown in Fig. 36. Figure 37 also shows deposits due to

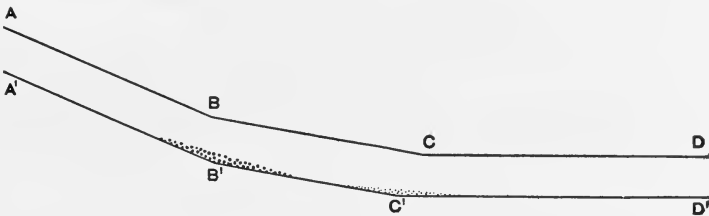

FIG. 36. Deposition Due to Decrease in Velocity

Longitudinal section of a stream. *ABCD* is the water surface, and *A'B'C'D'* the bed of the stream.

change of velocity from other causes, and each deposit is assorted. At times when the river is in flood it will bring down coarser material and we may get a little admixture of the new and the old which will spoil the assortment. In this way we get boulders deposited in the very middle of the stream, mixed with gravel and some sand; on the sides, sandy deposits, and here and there, where the water is very quiet, we find mud. On the inner curve of a stream we always find a sandy deposit because the water's velocity is checked somewhat as it rounds the bend.

*Stratification of deposits.* As long as the velocity of a stream remains the same, the character of the deposit at a given place will remain the same. But when the velocity changes, the coarseness of the deposit will change. Figure 38 shows a finer deposit overlying a coarser one. This is called *stratification*.



FIG. 37. Stream Deposits

At *A*, fine material is deposited behind a boulder where the water is quiet. At *B* we find gravel, because the velocity of the stream is checked by the headland. The boulders were brought down when the stream was in flood.

All river deposits are assorted and stratified, but the result is not nearly so perfect as that produced by wave action on the shore.

**67. Flood plains.** When a river in flood overflows its banks, the velocity of the flood waters is checked and much

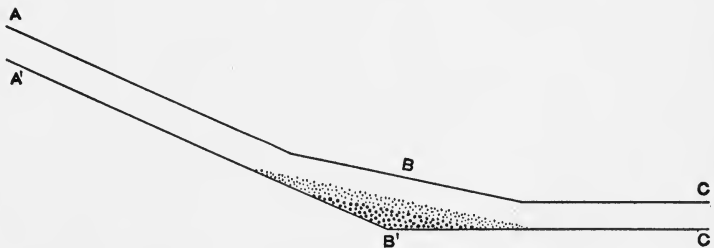

FIG. 38. Stratification of River Deposits Due to Decreasing Velocity

of the load must be dropped. This deposit, being level, forms a flat strip of ground, bordering the river on each side, which is called the *flood plain*, because it is subject to inundation



during floods. An old river like the Mississippi has a wide flood plain, while a young river, like the Colorado, has almost none.

**68. Natural levees.** The greatest loss of velocity, as a river spreads over its flood plain, occurs where the water leaves the channel, that is to say, along the banks of the river; and here the coarsest and the largest deposit is formed. This builds up each bank into a low ridge called a *natural*

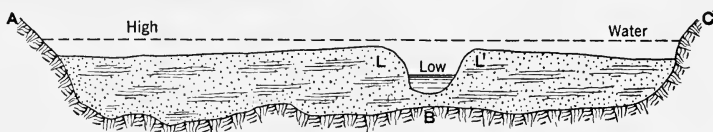

FIG. 39. Cross Section of a Flood Plain

*levee* (*L* and *L'* in Fig. 39). Natural levees are higher than the flood plain, some of them twenty feet high. They furnish good locations for home sites and roads.

Artificial levees are often built to protect the adjacent region from flooding. A break in a levee is called a *crevasse*.

**69. The delta.** When the velocity of the stream is suddenly checked at its mouth as it enters a large body of water, it must drop its entire load. This mass soon builds up and obstructs the path of the river. The river is therefore forced to find a new path on the two sides of the obstruction and sometimes, in flood, it overflows the mass of material. This finally builds up above the surface and assumes the shape of the Greek letter delta,  $\Delta$ ; hence this name is given to the deposit. The name *distributaries* is given to the system of stream channels through which the main stream finds its way into the sea or lake. To prevent the distributaries from being choked by sediment, engineers often build *jetties*. These are obstructions which narrow the river, increasing its velocity, so that it scours out a deep channel.

The material deposited at the delta builds out into the water and extends the length of the river. The Mississippi

is increasing its length about 250 feet a year. Since 400 B.C., the Rhone River has been increasing about 40 feet per year.

The Nile and the Danube increase only about 15 feet per year.

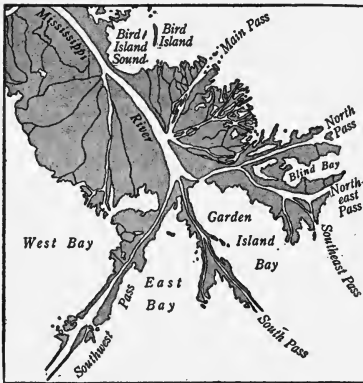

FIG. 40. The Delta of the Mississippi

The delta of the Nile is about 100 miles long and it is about 200 miles wide at the Mediterranean. The Mississippi delta is about 200 miles long but not so broad.

Deltas form at the mouths of all rivers; but sometimes wave action and shore currents spread the alluvium and prevent the formation of

a perfect delta. The St. Lawrence, the Susquehanna, and the Amazon have imperfect deltas for this reason.

### Completion Summary

A region is humid if there is enough rainfall to collect in pools and to run off.

Running water erodes by solution, somewhat, but chiefly by \_\_\_\_\_. Increase of velocity makes it possible for running water \_\_\_\_\_.

A stream cuts into its bed most rapidly at its \_\_\_\_\_. Here it is therefore young. As soon as it begins to \_\_\_\_\_ it is mature; and when it cannot cut any deeper into its bed \_\_\_\_\_. Every stream is old at \_\_\_\_\_, mature \_\_\_\_\_, and young at \_\_\_\_\_.

A river levels its valley with the help of \_\_\_\_\_. The stream pattern \_\_\_\_\_ dendritic.

Whenever a decrease in velocity \_\_\_\_\_, a stream \_\_\_\_\_ load. This deposit \_\_\_\_\_ size. In an arid region, the deposit is not uniform, because \_\_\_\_\_. We call it \_\_\_\_\_.

Rivers in humid regions \_\_\_\_\_ assorted deposits. There

may be some material of a different size in river deposits, because \_\_\_\_\_.

A flood plain is formed \_\_\_\_\_.

On the banks of the river \_\_\_\_\_ a deposit called \_\_\_\_\_.

At the mouth of a river \_\_\_\_\_ deposit, called \_\_\_\_\_.

Such a river enters the sea through its \_\_\_\_\_, which increase their length by deposition.

### *Exercises*

1. What is a humid region?
2. What happens to the rainfall?
3. How does solution aid in erosion?
4. Name two substances carried into the sea in solution.
5. How does weathering help running water in its work of erosion?
6. If a stream moves pebbles, one inch in diameter, when it flows at the rate of two miles per hour, what **size** boulders will it move at four miles per hour?
7. Why are streams muddy when they flow over shale?
8. When does a river erode its bed most rapidly?
9. When does a river become mature?
10. When does a stream become old?
11. Explain the phrase, "a river wears down mountains."
12. What is meant by dendritic drainage?
13. When does running water deposit part of its load?
14. Explain how an alluvial fan is formed.
15. Why are alluvial fans more common in arid regions?
16. Why does a river assort its deposits?
17. Why are river deposits not perfectly assorted?
18. How do deposits become stratified?
19. Explain how a flood plain is formed.
20. What type of river has practically no flood plain?
21. Explain how a natural levee is formed.
22. What is a crevasse?
23. Explain how a delta is formed.
24. What are distributaries?
25. How does a river increase its length at its mouth?
26. Why do some rivers have imperfect deltas? Name one.

**★Optional Exercises**

27. The diameter of a particle moved by running water varies as the square of the velocity. Show that the *size* of particle varies as the sixth power of the velocity.

28. If pebbles two inches in diameter are being moved by a stream whose velocity is two miles per hour, what size boulders could be moved at twenty miles per hour?

29. If a river is young, mature, and old at the same time, at different parts of its course, how can we call a particular river young?

30. What is the meaning of the expression, "the valley of the Hudson"?

31. Why do we not have dendritic drainage, if rocks on the surface are not uniform in hardness?

32. Does a stream deposit all its load when its velocity becomes zero? What kind is not dropped? Why?

## CHAPTER VII

### RIVERS

★70. **Rivers as highways.** As civilization spreads to unknown lands, explorers find great forests covering all humid regions except in the vicinity of the poles. The eastern part of North America, for example, was a dense forest crossed only by trails along which the Indians traveled in single file, because the trails were too narrow to allow them to do otherwise. Some of these trails, doubtless, may have allowed travel on horseback by the earliest settlers, but there were no wagon roads at all.

The principal highway used by the Indian was the river, and the direction of travel, exploration, and settlement by white men was controlled by the locations and the courses of the rivers.

The extent to which river highways expedite exploration is well illustrated by the relative progress of the French and English explorers of North America. The English who settled at Jamestown east of the Appalachian Mountains found only short rivers, and in 150 years extended their domain only as far as these rivers enabled them to travel.

The French, however, settling at the mouth of the St. Lawrence, quickly occupied the whole of the St. Lawrence Basin, including the Great Lakes, and crossed the height of land that separates it from the Mississippi Basin, at various "portages" marked  $x$  in Fig. 41. Each portage led to a tributary of the Mississippi and made it possible to reach any part of the great Mississippi system with its thousands of miles of navigable water.

In 1750 the French claimed most of the territory between the lines  $AB$  and  $CD$  in Fig. 41, although they had only about 80,000 inhabitants in the region, whereas the English, with a population almost 20 times as great, were confined to the smaller area between the line  $AB$  and the coast.

Comparison of the census of 1790 with that of 1820 shows that our population advanced during that interval along the Ohio and

Cumberland rivers to the Mississippi, and thence south to New Orleans and north to Quincy, Illinois; it indicates also that population followed the Missouri River to Kansas City, showing that the settlers used the rivers as highways.

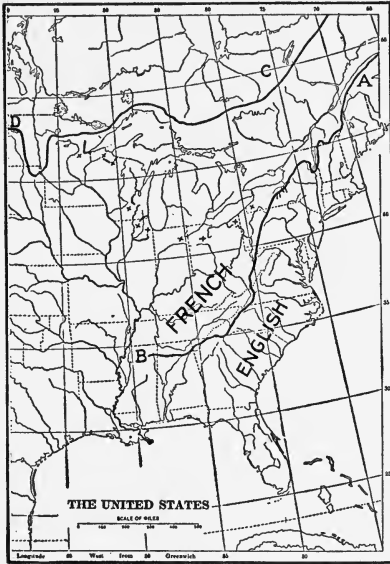

FIG. 41. Illustrating the Influence of Rivers on Exploration

Many explorers, besides the French, used the rivers of North America as highways. The Spanish came up to Santa Fe from Mexico along the Rio Grande; the Frémont Expedition of 1842 followed the South Platte, and the Lewis and Clark expedition followed the Missouri, the Yellowstone, and the Columbia.

Besides the excellent highway for boats which rivers provide, many river valleys furnish a graded location for wagon roads and railroads that engineers find better than any

other location in the region, and hence roads usually follow rivers.

As a rule, roads that cross the stream are located at shallow places that can be forded or narrow places that can be bridged cheaply; and in the case of canyons or steep-sided valleys, the crossings are at gaps in the valley wall. The "Spanish Trail," in western United States, crossed the Green River of Utah where there is a gap in the canyon wall, and our railroads now use the same gap.

Where there is sufficient travel to warrant the expense of a bridge, neither the deep river, the rapids, nor the canyon is an insurmountable barrier.

★71. **Rivers and commerce.** Just as the canoe was the chief means of travel in North America, in the early days, so the flat-boat was the chief means of transporting freight. The river was the first artery of commerce in all countries. Ancient histories tell us of boats propelled by oars, poles, or sails, carrying cargoes on the Nile and on the Euphrates.

The transportation of commodities downstream on the Mississippi became so important in the early days of the last century as to lead to the "Louisiana Purchase." The journey upstream with a flatboat was slow and difficult, sometimes lasting several months; but the boats could carry many tons of freight, required small crews, and traveled downstream without power at the rate of four or five miles an hour.

The appearance of the steamboat on the Ohio River in 1811 decreased the time required for upstream journeys to about 5% of that formerly required, and caused a great increase in the volume of freight carried on the river. As a result, freight charges were reduced to about one fourth of the former rates.

When railroads were built, transportation by boat in America began to decline, because (1) river transportation is slower than rail transportation; (2) it is often obliged to follow roundabout routes; (3) it must be suspended (in the north) in winter; (4) it is suspended during the summer, on many streams, because of low water.

Even with these disadvantages, river transportation has exercised a salutary influence in controlling the average rate per ton-mile for the transportation of freight. In 1837 the average charge made by railroads was seven and one third cents per ton-mile. It had dropped to less than one cent per ton-mile by 1905. Railroads and auto trucks are now carrying most of the passenger and express traffic of this country, including all perishables and all light articles; but they cannot compete with the river transportation companies in handling heavy or bulky freight, especially when carried downstream.

In 1925 the Ohio River and its tributaries carried about 16,000,000 tons of coal, lumber, gravel, and sand, and more than 75 per cent of it was carried downstream. On the Mississippi, coal, lumber, and sand are carried downstream; and some of the products of the delta regions, such as cotton, sugar, rice, and petroleum, are carried upstream.

Exceptionally favorable conditions for transportation on the Great Lakes have enabled the companies operating there to control much of the freight business of the region through the low cost of transportation. In 1909 the through rate for iron ore from Lake Superior was less than one mill per ton-mile, whereas the rate by rail was one cent per ton-mile.

The "Soo Canal" around the falls of St. Mary makes it possible for boats to pass from Lake Superior to Lake Huron; and although the canal is closed for about five months every year, it carries about four times as much freight during its seven months' period as the Suez Canal carries during its twelve months' season. Eastbound freight through the "Soo" is principally iron ore and grains; westbound freight is principally coal. Much lumber, however, comes through the "Soo," and much more is shipped from the shores of Lake Michigan and Lake Huron.

★72. **River transportation in Europe.** The rivers of Europe have been "corrected" and improved at great expense and are of much greater relative importance, in comparison with railroads, than are the rivers of the United States at the present time. This is partly due to the greater relative mileage of railroads in this country, but there is no doubt that business will be greatly stimulated and the cost of manufactured articles greatly diminished when the thousands of miles of navigable rivers and canals in the United States are developed as highly as they are in Europe.

★73. **Rivers and water supply.** Man has always gone to streams for a large part of his water supply, both for household purposes and for irrigation. Practically all rivers furnish water suitable for irrigation, but great care must be exercised to secure water suitable for drinking purposes, for the following reasons:

1. Streams that are safe for drinking at their ordinary stage become unfit for drinking when at flood stage because of filth washed into them from the land.

2. Water that appears and tastes as though it were absolutely pure may be loaded with the germs of certain contagious diseases.

3. Sewage may be discharged into the stream above the point at which the water is used.

Many towns empty their sewage into a river, thus endangering all towns that draw water from the river below them. Notable instances of this practice are found at many points on the Great Lakes and on the Mississippi River. Where most of the cities depend upon the river or the lake for their water supply and empty their sewage into the same body of water at a point some distance below their waterworks intake, such conditions always oblige cities to purify their water before it is safe to use. Most of the cities on the Mississippi go to the river for their water supply, and



so do some of the cities on the Hudson, Connecticut, and other rivers.

New York City derives most of its water supply from streams. The old Croton system depends upon the Croton River Basin, and the new Catskill system upon the upper portion of the Basin of Esopus and Schoharie Creeks and some near-by streams.

It is obvious that densely populated stream basins are more likely to contain impure water than sparsely populated basins, and many states give their cities sanitary control over the basin from which they draw their water. In spite of such control, New York City has found it increasingly necessary to purify the water from the Croton system with chlorine, in order to prevent the recurrence of epidemics of typhoid fever.

★74. **Military advantages.** The feudal castle was surrounded by a deep moat as a means of defence. Modern armies frequently select positions with a natural moat; i.e., with a river between them and the enemy. The degree to which a stream aids an army depends upon the characteristics of the stream. A frozen stream, a dry stream, or a shallow stream with a wide, open valley would only slightly retard the advance of an enemy. A deep river would require bridges, and these might be destroyed by artillery as fast as an enemy could rebuild them.

A canyon like that of the Colorado and a gorge like that of the Niagara, or rapids like those near Niagara Falls, would be practically impassable for an attacking army and would prevent a frontal attack upon an army defending them. Many illustrations of this use of rivers are to be found in history. In the Battle of New Orleans, 1815, the Mississippi, and in the World War, the Marne, the Aisne, the Dnieper, the Tagliamento, and the Piave were thus used.

★75. **Rivers as national boundaries.** The fact that rivers can be easily described in deeds and treaties has led to their wide use as national boundaries. In our own country the Mississippi was once the western boundary; the Rio Grande is our present boundary for some distance on the south and the St. Lawrence on the north. The Missouri River separates Nebraska and Kansas from Missouri and separates Iowa from South Dakota. In none of the instances mentioned, excepting perhaps that of the St. Lawrence, has the river proved to be a satisfactory boundary, because of the tend-

encies of the rivers concerned to shift their channels. There have been controversies between several states bordering the Missouri and Mississippi rivers and between the United States and Mexico because of the shifting channel.

The only satisfactory boundary line for a nation is one possessing military advantages like a canyon or a mountain range. The Niagara River, from the Falls to Lewiston, is an ideal national boundary; its channel does not shift, it prevents smuggling, and in case of war it would need no defence except where the gorge was bridged.

**76. How a river grows.** Every permanent river rises on high land and flows down grade, ultimately joining some large body of water, a lake or an ocean, but it grows or it lengthens in the opposite direction. Every rain forms a few new rills, possibly a gully, through which the runoff finds its way into the river. Each successive rainfall deepens some of these new channels until they become permanent tributaries of the main stream, which has increased its length as outlined above by *headward erosion*.

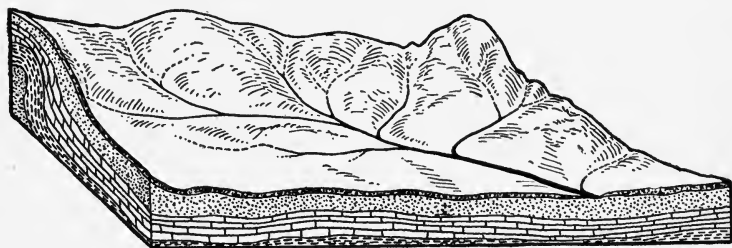

FIG. 42. Headward Erosion

The dotted lines show temporary streams which will become permanent tributaries.

In the meantime, other streams are developing in the same way until they divide up the entire region among them. The ridge which separates two drainage systems is called the *divide* (Fig. 43). The valley of a river is the depression cut out of the land by the river and all its tributaries, but in a broader sense it refers to the entire drainage area of the river.

77. **Stream capture.** As rivers grow headward, one of them may succeed in cutting down faster than another, possibly because its slope is greater or because its bed is

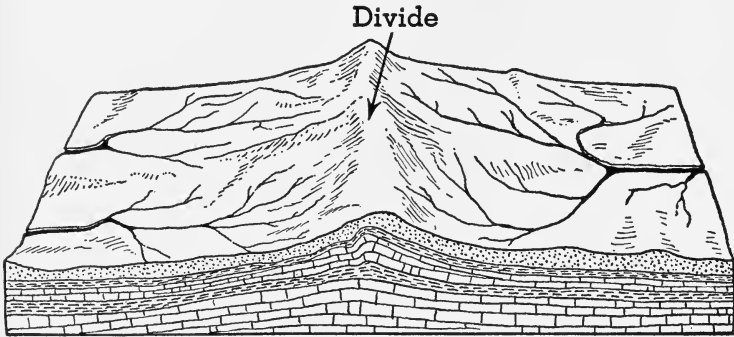

FIG. 43

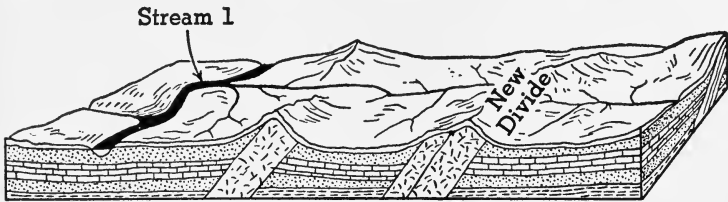
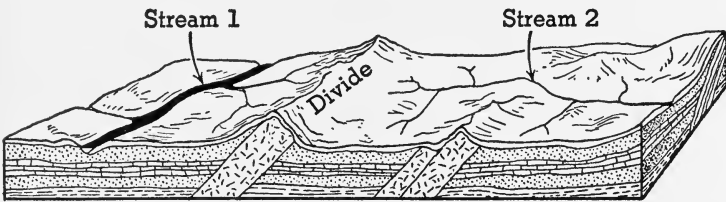
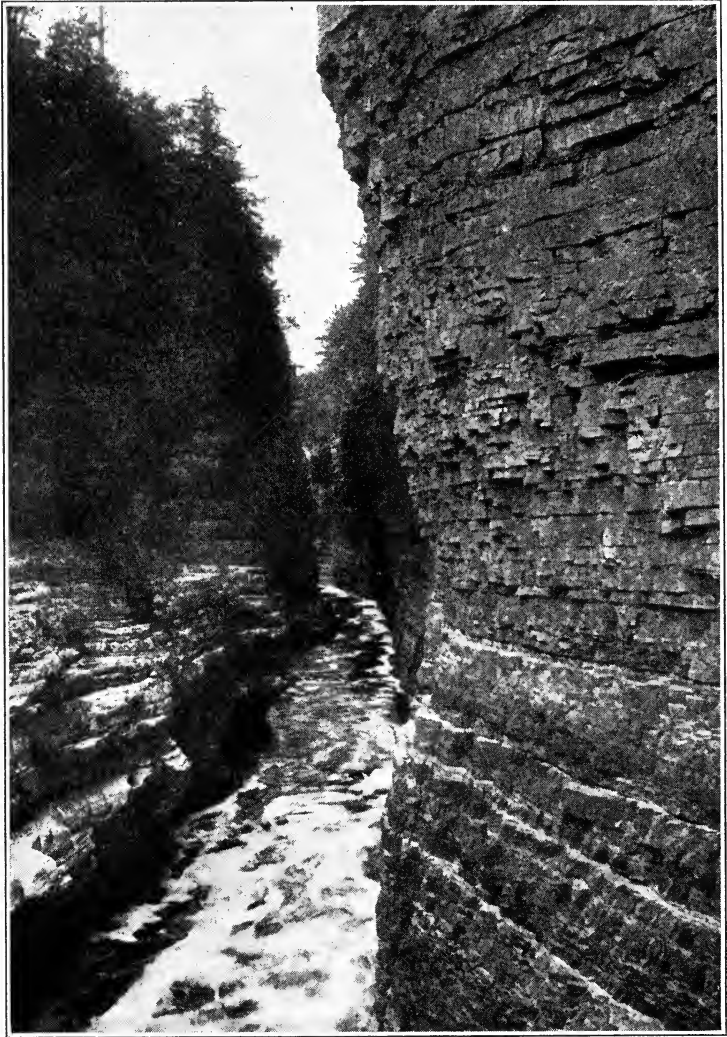

FIG. 44. Stream Capture

Stream 1 has cut through the divide and captured the headwaters of Stream 2, forming a new divide.

softer. Ultimately it may penetrate the divide, diverting the headwaters of a rival stream. This is called *stream capture* or *stream piracy*. It is shown in Fig. 44. Stream 1 has



*Photo by Ewing Galloway*

FIG. 45. The Ausable Chasm

breached the divide, captured Stream 2, and formed a new divide.

**78. A river in youth.** The gradient of a youthful river is

steep. It bites deeply into its bed; it flows in a straight course, overriding obstacles in its path. While the stream cuts down, weathering plays its part on the new surfaces exposed and the loose material thus formed is washed into the stream.

This widens the valley at the top, giving it a V-shaped appearance. If the bedrock is hard and resistant, the weathering process may act much more slowly than the downcutting of the stream. In that case the river will cut a *gorge* with almost vertical sides (Fig. 45).

Young rivers are not deep, because the water runs too

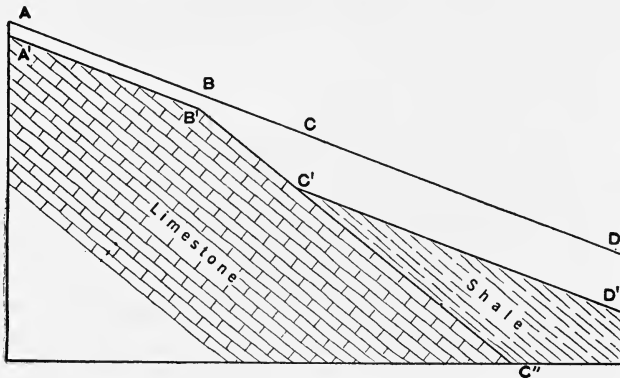

FIG. 46. Diagram of Rapids Due to Erosion

rapidly. In places the bedrock may be visible where the slope is very steep, while in other places, boulders interrupt the movement of the water. Such features are called *rapids*. Rapids are sometimes developed by a stream itself, because of difference in the rates of erosion of two kinds of rock in the stream bed. Figure 46 shows limestone and shale, which were in contact with each other along the line  $B'C'$  when the stream was at the level  $ABCD$ . The shale eroded faster than the limestone, developing the present bed of the stream  $A'B'C'D'$  with rapids from  $B'$  to  $C'$ .

If the strata dip downward toward the mouth of the stream, as in Fig. 46, mentioned above, the rapids will be

quite permanent; but if they dip toward the source of the stream, as in Fig. 47, or if they are horizontal, the rapids will soon develop into a waterfall, unless the stream is a small one.

**79. Waterfalls.** The typical waterfall is one over which the water tumbles vertically as it does at Niagara. Between this and the typical rapid, there are all degrees of slopes, which might be called *cascades*. Falls are due, as a rule, to differences in the resistance of the rocks forming the bed of the stream. Some, like Niagara, St. Anthony, and the

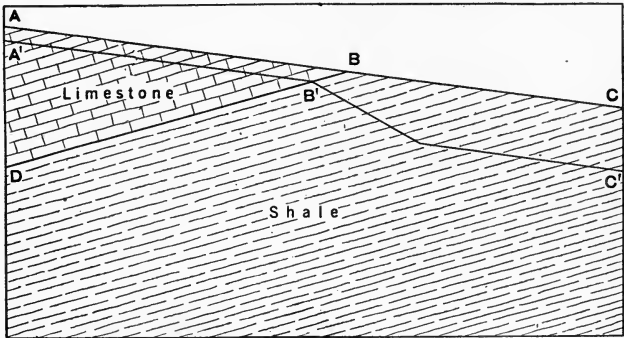

FIG. 47. The shale erodes faster than the limestone, forming a waterfall at B.

Great Falls of the Missouri River, are due to a cap of resistant rock that overlies a mass of weaker rock (Fig. 48).

Others, like the two falls of the Yellowstone, and the Passaic Falls at Paterson, New Jersey, are due to igneous rock, which offers much greater resistance to erosion than the rocks above and below it.

Occasionally, falls are found at the point where a tributary joins the main stream. Such falls have been caused by a deepening of the channel of the main stream by glacial erosion (Fig. 49). The tributary stream which has been left hanging above the main stream is then said to have a *hanging valley*. There are many falls, due to hanging valleys, in the Finger Lakes of New York, like the one at the mouth

of Watkins Glen. These were all formed by the gouging out of the lake beds by a great glacier.

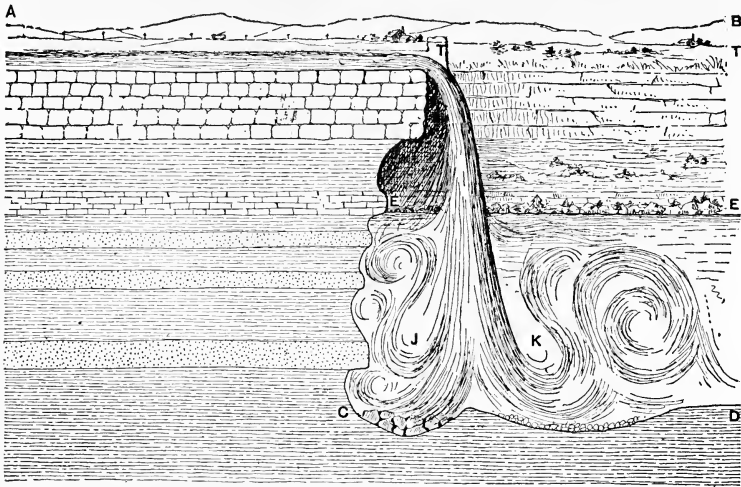

FIG. 48. Niagara Falls, Showing Layer of Limestone Overlying Weaker Rocks

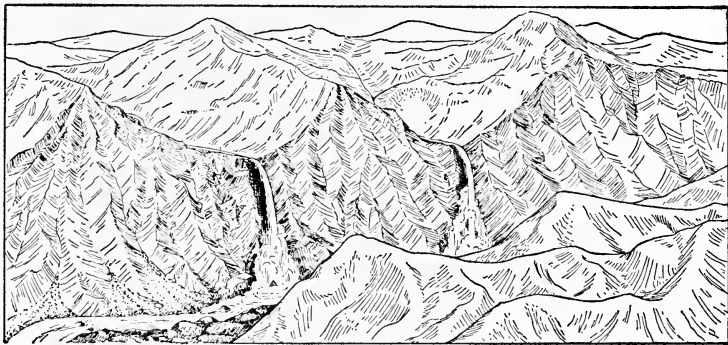

FIG. 49. Hanging Valleys

In many instances, a mass of debris dropped by a glacier in the path of a river has dammed it up and caused the water to overflow the dam.

Along our Atlantic coast, a number of rivers originating on the eastern slope of the Appalachian Mountains form

falls or rapids. This has resulted from an uplift of the entire Atlantic coast region, which increased the gradient of all the rivers. These rivers naturally cut more rapidly in the softer sedimentary rock of the uplifted coastal plain than in the old crystalline rocks in the mountains, and therefore the *fall line* was developed close to the contact between the



FIG. 50. Map of the Fall Line

sedimentary and the crystalline rocks.

At the bottom of falls, *potholes* are frequently formed. They are caused by stones whirled around and around by the water, as at *C* in Fig. 48.

**80. Waterfalls are temporary features of streams.** Erosion at a waterfall is much greater than elsewhere since the gradient is steeper. Hence, falls usually migrate upstream and finally disappear.

Many falls, like Niagara, are situated on the upstream end of a gorge of

considerable length which has been formed by the recession of the fall. It has been shown by careful surveys that the center of the Horseshoe Falls at Niagara is traveling toward Lake Erie at the rate of about five feet a year. Similar though less rapid recession takes place in all falls of this structure.

Examination of Figure 48 will explain why the falls at Niagara recede. The falling water, as it strikes the bedrock, forms two whirlpools, *J* and *K*. These pick up the rock fragments and dash them against the face of the cliff with great force, cutting away the soft underlying shale and undermining the harder limestone cap rock. As the support



is cut away from under the limestone, it finally breaks and falls.

★81. **Locks.** Both falls and rapids interfere with navigation, but the great value of their water power leads engineers to try to prevent their destruction and to build *locks* and canals, so that vessels may pass the falls or rapids safely. Figure 51 shows a vessel in the lock at St. Mary's Canal passing from Lake Superior to

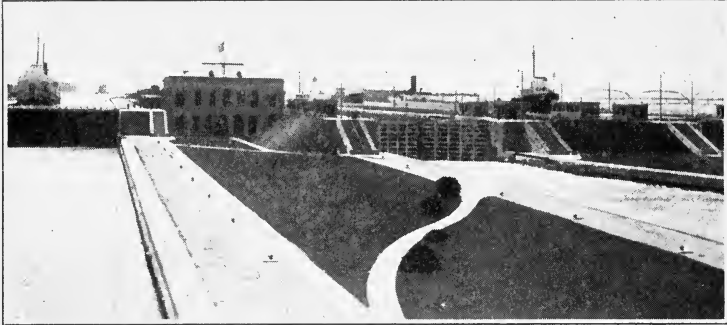

*Courtesy of U. S. War Department*

FIG. 51. Locks of the St. Mary's Canal

Lake Huron. In the illustration one gate is seen, but there is another one at the other end. When the vessel wishes to go from Lake Superior to Lake Huron, the gate at the Lake Superior end is opened, while the other gate remains closed, and the vessel enters the lock. The Lake Superior gate is now closed, and water is permitted to run out of the lock to the Lake Huron side. When the water in the lock is at the level of Lake Huron, the gate is opened and the vessel may leave.

When the difference of elevation is too great, a series of locks is made use of. At Trollhätte, Sweden, three locks are used to overcome a fall of 77 feet. The two Gatun locks on the Panama Canal lift vessels a total of 85 feet.

82. **Water power.** Satisfactory conditions for the development of water power may be obtained on any stream with a steep slope by building a dam across the stream, thus forming an artificial fall and providing a reservoir that will store water for use during a dry season. A dam across

the Mississippi at Keokuk, Iowa, develops 300,000 electrical horsepower which is transmitted to St. Louis, 144 miles away. The Susquehanna River generates 120,000 horsepower which is sold in Baltimore and Philadelphia. But water-power plants are chiefly found on young rivers or in the young section of an older river, that is, nearer the source of the river. This is true for several reasons. Young rivers

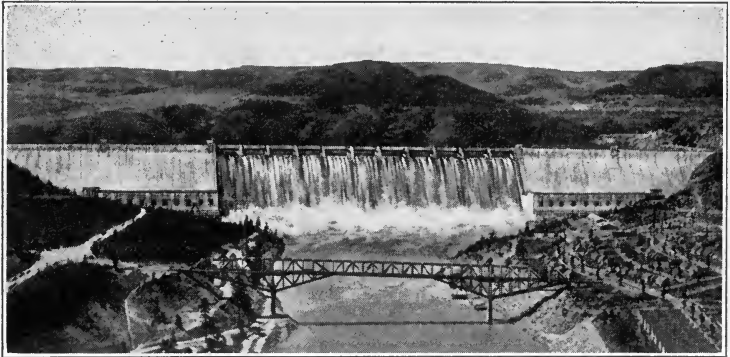

FIG. 52. Developing the Water Power of the Columbia River

are not usually navigable and can therefore be dammed up without obstructing river traffic. Also it is easier to build a dam on a young river, because of its narrow profile. The water flows more rapidly in a young stream, developing more power per unit of volume.

The estimated output of all the water-power sites in the United States is 80 million horsepower, of which about 16 million (about 20%) was being utilized in 1936. Niagara Falls supplies power to a great portion of New York State, as far as Syracuse, 200 miles away. A large section of the South will be supplied by the Muscle Shoals hydroelectric plant on the Tennessee River, aided by the plants on the Coosa and Tallapoosa rivers. The Boulder Dam project on the Colorado River will supply power and water to Los Angeles and the neighboring territory, and the Grand Coulee Dam will develop the resources of the Pacific Northwest.

San Francisco gets power from the Sierra Nevada Mountains at Colgate.

Great Falls, Montana, is one of a number of important falls on the eastern slope of the Rocky Mountains.

Falls that have played an important part in the development of the textile industry of New England and in the growth of the cities near them are located at Fall River, Fitchburg, Lawrence, Lowell, and Taunton, Massachusetts; at Manchester, N. H.; at Lewiston, Maine; at Pawtucket and Woonsocket, R. I.

Other cities, located along the fall line where they can make use of the water power, include Passaic, N. J.; Philadelphia, Pa.; Baltimore, Md.; Washington, D. C.; Richmond, Va; Raleigh, N. C.; Camden and Columbia, S. C.; and Augusta, Ga.

In New York State, water power is obtained from three groups of streams: (1) Streams flowing into Lake Ontario provide power at Niagara Falls, Rochester, Auburn, Oswego, and Watertown; (2) the Hudson and its tributaries at Troy, Glens Falls, and Cohoes; (3) rivers of southern New York at Jamestown, Binghamton, and Elmira.

The city of Minneapolis obtains water power from the falls at Sault Ste Marie in Michigan, while in other parts of the country, power is obtained from rapids, notably those of the St. Lawrence River.

**83. A river in maturity.** A mature stream no longer has steep sides, the slopes having been reduced by downcutting during youth (Fig. 53). Rock mantle produced by weathering is no longer swept down into the valley so rapidly. Instead, it fills in the irregularities of the surface, rounding off the angles of youth into the gentle curves of maturity.

Rapids and falls have largely disappeared and the streams, having lost much of their velocity, can no longer flow over or sweep aside every obstacle in their path. The water now lingers a bit longer at each level and does more sidewise cutting, widening the valley and developing a *flood plain*.

★84. **Influence of mature topography on man.** Agriculture is confined chiefly to flood plains, although it has to contend with spring floods there.

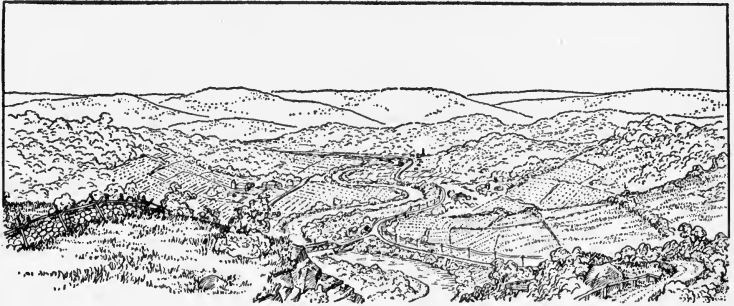

FIG. 53. A Mature Region with Its Gentle Curves

Navigation is interfered with by sand bars and the low water of summer months. Roads and railroads are, as a rule, located in the stream valleys, and flood plains are the only areas for townsites or for farming.

Mining is the most important industry of the interstream spaces in many mature regions, because of the ease with which we may discover valuable minerals which have become exposed by erosion of the bedrock.

Other possible industries are forestry, hunting, and trapping; but in the absence of mining, the inhabitants of these regions usually live a life of poverty, hardship, and ignorance.

**85. Economic importance of flood plains.** The soil of flood plains is often very fertile, and the level ground is easily tilled. The river furnishes water and provides an easily traveled highway on which the farm products can be carried to market. These two characteristics, fertile soil and accessibility, have made flood plains so desirable that they are nearly everywhere densely populated.

The flood plain of the Mississippi, below the mouth of the Ohio, is from 20 to 50 miles wide and about 600 miles long. The region is densely populated and fine crops of corn, cotton, and sugar cane are raised there.

The flood plain of the lower Rhine in Holland is one of the most densely populated and carefully cultivated regions of Europe. The flood plain of the Yellow River, in China, probably has the densest population in the world.

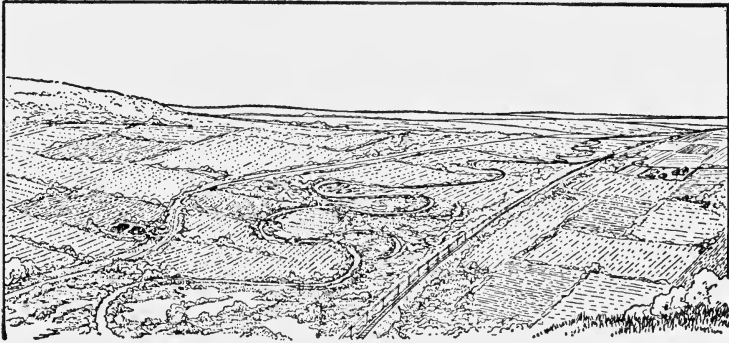

FIG. 54. An Old River, Showing Its Meandering Course and Wide Flood Plain

The advantage derived from living on flood plains is shown in history. Egypt developed on the flood plain of the Nile, and Chaldea and Babylon on the plains of the Euphrates and the Tigris. These rivers were so important among the ancients that the period before 800 B.C. is sometimes referred to as the "fluvial (or river) period" of history.

**86. An old river.** The velocity of a river in old age is so far reduced that it is turned aside by the slightest obstacle. Hence its course becomes very crooked and winding and the flood plain is very much widened. The river is wide, but deposition of material in its channel makes it shallow. Hence in the spring, floods are common, and these deposit alluvium on the banks, forming natural levees. Gradually the stream is built up on a higher level than its flood plain so that rain falling on the flood plain cannot flow into the main river and swamps develop all along the natural levees. For the same reason an old river has very few tributaries.

**87. Meanders.** The winding streams characteristic of old regions are called *meanders* after a small river of that name

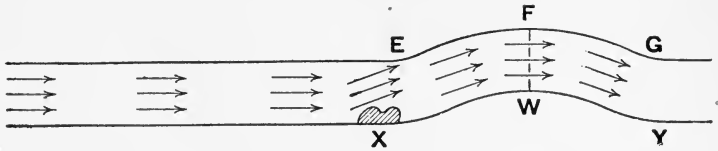

FIG. 55. Development of Curves in a Stream

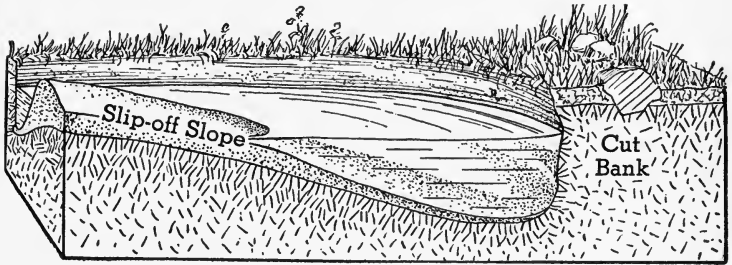

FIG. 56

in Asia Minor. When a stream is moving in a straight course, there is little erosion of the banks. But an obstruction will cause slowly moving water to be deflected as shown in Fig. 55. The water will then be deflected back to the other side and begin undercutting at Y. In this way, once the river has started to curve it continues to do so and becomes more and more curved.

FIG. 57.  
Growth of  
a Meander

On the outside of a river curve, there is usually a vertical wall called the *cut-bank*, because here erosion is greatest. On the opposite side the velocity is least and deposits will be formed. This is called the *slip-off slope* (Fig. 56).



It is evident that as the stream cuts away one bank, as at A and B, Fig. 57, and deposits material on the slip-off slopes at C and D, the course of the river will be more crooked than it was.

**88. Cutoffs and oxbow lakes.** The meander, shown in Fig. 58, has developed to such a point that the two cut-

banks have been worn away, thus providing a shorter, straighter path for the water. The river now follows the new course, called a *cutoff*. Soon the entrances to the old channel will be blocked by deposits, since at those points the velocity of flow is less than in the main channel. This forms an *oxbow lake* (Fig. 59).

**89. Influence of old topography on man.** The area adapted to agriculture is greatest in an old region because flood plains are very wide. Portions of the flood plains may be wet and require draining, but the fertility of the land amply repays the farmer for his labor. Because of the absence of steep slopes, it is easy to build roads and railroads and therefore many towns will be located in old regions. There are no falls or rapids to interfere with navigation, but the deposition of silt is apt to obstruct the channel.

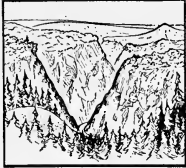
**90. Summary of the cycle of stream erosion.**

	YOUTH	MATURITY	OLD AGE
Profile			
Course	Rather straight	Branching	Meandering
Width	Narrow	Medium	Broad
Topography	Scenic; falls and rapids	Rounded; falls and rapids uncommon	Flat; no falls or rapids
Drainage	Poor; swamps and lakes in uplands	Good; no swamps or lakes	Good, except on flood plain
Vegetation	Sparse	Completely covered	Swampy
Flood plain	None	Developing	Wide. River has natural levees.
Tributaries	Few	Very many	Very few

**91. The interrupted cycle of stream erosion.** Many streams never complete their normal life cycle, from youth

to old age, because of sudden change of slope or change of climate. Change of slope is brought about by raising or lowering of the land.

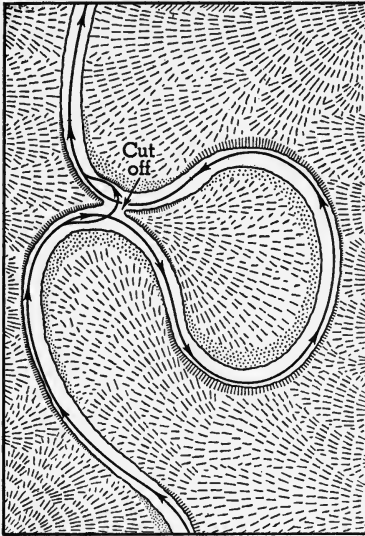

FIG. 58. A Cutoff

**92. Effects of depression.** When the land is lowered, the region increases in age and the cycle of stream erosion is shortened. The chief evidences of depression are to be found at the mouth of the river. Here the entire flood plain is drowned, producing bays, which when narrow are called *estuaries* or *fiords*. Most of the rivers on the Atlantic coast have been drowned, and it is this feature which is responsible for the fine harbors found there.

**93. Effects of elevation.** When the land is raised, the region becomes more youthful since streams begin to cut into their beds once more. Such a region is said to be *rejuvenated*. If the uplift is slow enough to permit the stream to cut down as fast as it is raised, then its course will not be altered by a mountain which rises across its path; instead the river will cut right across the mountains, maintaining its original course. This is an *antecedent* river, so called because it antedated the present topography. An antecedent river cutting across a mountain chain

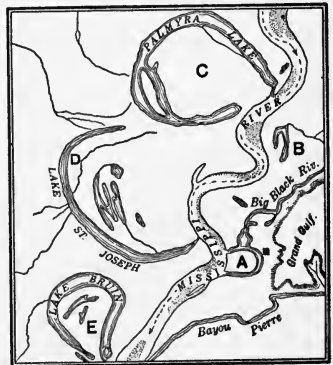

FIG. 59. Oxbow Lakes, Sand Deposits, and Main Channel of the Mississippi River



produces a *water gap*. Thus the Green River passes through the Uinta Mountains and the Hudson River through the

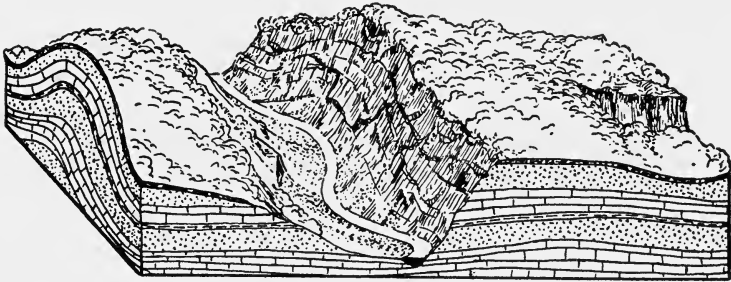

FIG. 60. Water Gap Cut by an Antecedent Stream

Highlands. The Delaware, the Susquehanna, and the Potomac rivers have cut water gaps across the Appalachian Mountains; hence they are antecedent streams.

★The capture of an antecedent river may dry up a water gap, leaving what is then called a *wind gap*. A good illustration of a wind gap is shown in Fig. 61. The greater volume of the Potomac

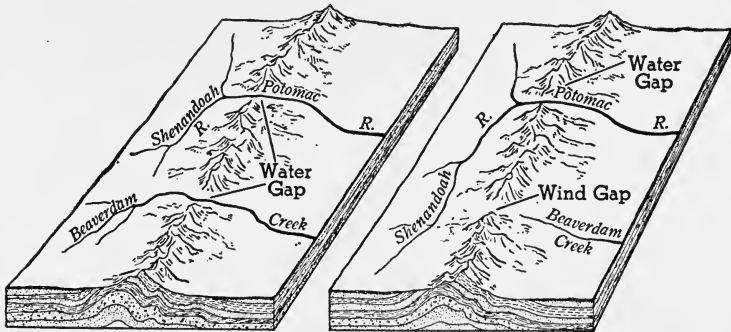

FIG. 61. Showing how a Water Gap Is Changed into a Wind Gap

River enabled it to erode the rock more rapidly than Beaverdam Creek. This increased the gradient of the Shenandoah River so that it captured the head waters of Beaverdam Creek, leaving the wind gap instead of a water gap. The name wind gap is deceptive. Wind action has had nothing to do with its formation.

When a region is uplifted, a stream is made younger and straightens its course, but if the uplift is so rapid that sidewise cutting cannot keep pace with downward erosion, a meandering river will maintain its course, forming a deep meandering gorge, called an *entrenched meander*.

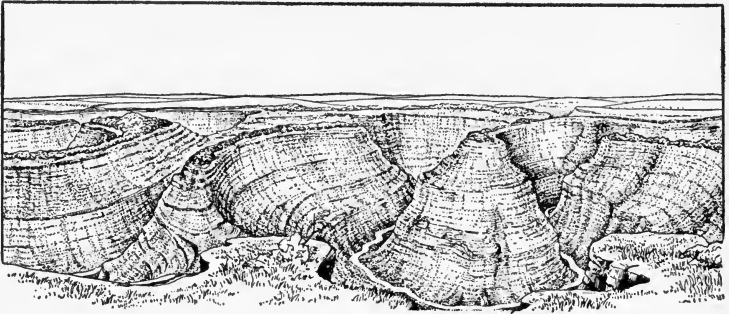

FIG. 62. An Entrenched Meander

Rivers entrenching themselves in flood plains sometimes leave portions of the old flood plain, which remain as *river terraces*. These consist of rather flat beaches, paralleling the river on both

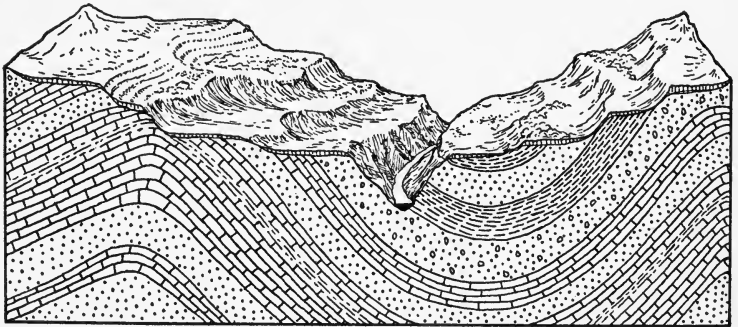

FIG. 63. River Terraces

sides and at the same elevation above the present flood plain. They are often composed of alluvial material or of rock thinly covered by alluvium. Sometimes we find several pairs of terraces at different elevations: good evidence of successive uplifts of the region.

### *Completion Summary*

A river increases its length by \_\_\_\_\_.

The \_\_\_\_\_ may be defined as the line which separates two river systems. When one stream cuts through the divide and drains the area occupied by another, we call that stream a \_\_\_\_\_.

A young stream \_\_\_\_\_ valley, due chiefly to its velocity. It has waterfalls, but \_\_\_\_\_ flood plain. Falls are destroyed \_\_\_\_\_.

★Falls and rapids obstruct \_\_\_\_\_, but this may sometimes be overcome by \_\_\_\_\_.

Water power is usually developed on \_\_\_\_\_ streams, because \_\_\_\_\_.

A mature stream has no \_\_\_\_\_. Its flood plain \_\_\_\_\_, and the region which it drains is \_\_\_\_\_, and \_\_\_\_\_ forests \_\_\_\_\_.

The old river can be started on a \_\_\_\_\_ course by any obstruction, because \_\_\_\_\_. Once started, a meander \_\_\_\_\_ more and more \_\_\_\_\_; until a cutoff \_\_\_\_\_. From the cutoff, an \_\_\_\_\_ is easily developed.

An old river \_\_\_\_\_ flood plain, which is so called because \_\_\_\_\_. The sluggishness of an old stream causes it to deposit \_\_\_\_\_, and the bottom is \_\_\_\_\_ higher than the \_\_\_\_\_. It is therefore not deep and \_\_\_\_\_ floods. During the flood stage, deposits \_\_\_\_\_ and natural levees \_\_\_\_\_. An old river \_\_\_\_\_ tributaries because \_\_\_\_\_. From this, \_\_\_\_\_ swamps \_\_\_\_\_ river.

When a region is depressed in level, it becomes \_\_\_\_\_. An important feature of the rivers of such a region \_\_\_\_\_.

If a region is uplifted, \_\_\_\_\_ youthful. \_\_\_\_\_ rivers may be formed which may \_\_\_\_\_ water gaps.

★If an \_\_\_\_\_ river is captured, the water gap becomes \_\_\_\_\_. Uplift may \_\_\_\_\_ the meandering stream, but if downcutting keeps pace with uplift \_\_\_\_\_ entrenched.

*Exercises*

1. State several reasons why rivers aid in exploration.
2. Why may it be unsafe to use river water for drinking?
3. What difficulty is sometimes met in using a river as a national boundary? What type of river would not have this disadvantage?
4. What is meant by headward erosion?
5. Explain how a river grows.
6. What is the divide? Explain by diagram.
7. Explain stream capture.
8. What are the characteristics of a young stream?
9. Under what condition would a young stream not have a V-shaped profile?
10. Why are young streams shallow?
11. Explain the formation of rapids.
12. Explain with diagram one way in which a waterfall develops.
13. What is a hanging valley?
14. How are potholes formed?
15. Why are waterfalls only temporary?
16. Explain the recession of Niagara Falls.
17. Explain how navigation may be maintained on a river with rapids.
18. Explain the action of locks in river navigation.
19. What type of river is best suited to the development of water power? Why?
20. Name five cities located on the fall line of the Atlantic Coastal Plain. Give reasons for their location.
21. Why do steep slopes disappear in maturity?
22. State the characteristics of a mature river.
23. Why is agriculture confined chiefly to flood plains?
24. What are the characteristics of an old river?
25. Explain the development of a wide flood plain.
26. Show how the bed of an old river is built up above its flood plain.
27. Explain the formation of natural levees. Why are they features only of an old river?
28. For what two reasons are floods common on old rivers?

29. How are swamps developed along the course of an old river?
30. Why has an old stream few tributaries?
31. Show by diagram how an obstruction starts a meander in an old stream.
32. Make a diagram showing cut-bank and slip-off slope.
33. Explain how a cutoff is formed. Why doesn't this happen on a young river?
34. Why does an oxbow lake form on an old river?
35. Why are old regions likely to be densely populated?
36. In what kind of region do we have the best drainage? Why?
37. What is the chief effect of depression on the cycle of stream erosion? Where does it show most?
38. Explain the formation of a water gap.
39. What is an antecedent river? Name one.
40. Explain how a river can be young and old at different parts of its course.
41. What effect would a change of climate, from moist to arid, have on the cycle of stream erosion?

### ★*Optional Exercises*

42. Write a short article on the effect of river transportation on railroad freight rates at the present time.
43. Write a short analysis of the development of the steel industry in this country around the Great Lakes, because of the low rates for transportation.
44. Explain the value of a river in a scheme of military defense.
45. Write up the subject of water power in the United States from the standpoint of power supply, irrigation, flood control, and soil erosion.
46. Explain the development of the flood plain from youth to old age.
47. What would happen to an oxbow lake if the region were uplifted?
48. In paragraph 90, the drainage of a young stream is classed as poor. Explain how that can be so, in spite of the rapidly flowing streams.
49. Explain how a wind gap is formed.

50. How is an entrenched meander formed? What does the presence of an entrenched meander tell about a region?
51. What relation exists between river terraces and uplift?
52. When a river is "born", it is old. As it grows, it becomes younger. Explain the paradox.

## CHAPTER VIII

### FLOODS AND FLOOD CONTROL\*

★94. That the problem of floods is becoming more and more pressing is shown by the increasing property losses. In 1913 the losses in the Mississippi Valley were 162 million dollars while in 1927 they amounted to 284 million dollars. It was in 1927, also,



*Courtesy Army Air Corps*

FIG. 64. A Flood on the Ohio River

that exceptionally severe floods inundated New England. In 1936 the spring floods, swelled by heavy rains, again caused untold suffering and damage and it begins to look as if we may expect frequent, if not annual, repetitions.

★95. Where do we get floods? In young, mountainous regions, the problem of flooding is not very important. The rivers have

\*This entire chapter is optional.

steep sides and therefore little flooding results. In the Rocky Mountain regions, especially along the Missouri River, cloud-bursts cause local flooding which results in washouts on railroads, damage to roads, and silting-up of irrigation ditches. But these floods subside rapidly.

In an old region, on the other hand, a stream builds up natural levees, which confine it except during time of high water, when it breaks through with disastrous results. It is in the Mississippi Valley, therefore, where the streams are old and the flood plain wide, that we get most of our floods.

Wherever the winters are severe, as in northern United States and in mountainous regions, the melting of snow in the spring will cause annual floods. On the Merrimack River at Lawrence, Mass., there have been 153 floods, between 1880 and 1933, in the months of March, April, and May.

In western United States maximum flooding occurs in early summer while on the Pacific coast, late spring or early summer floods are caused by melting snows in the highlands.

**★96. Effect of the rainfall.** If the precipitation of rain is well distributed through the year, as it is in New England, few floods will occur. In semiarid and arid regions, the rainfall is too small; but even there, the steep slopes and lack of soil will permit very rapid runoff which may result in local flooding.

In the West, the maximum precipitation occurs in the late spring, and on the Pacific it is in the winter; hence flooding is common during the spring or early summer.

**★97. Relation of floods and soil.** Porous soils permit very little runoff; most of the rain sinks into the ground. The Atlantic and Gulf coasts, therefore, seldom experience a flood, because of the porosity of the sands of the coastal plains, although the rainfall is fifty inches per year. In the Great Lakes region, the soil is glacial drift, which is likely to be porous.

When the soil consists largely of clay, it is not porous. Hence the runoff is greater, soil erosion is increased, and flooding becomes more and more common.

Needless to say, the surface runoff increases with the degree of slope. On a gentle slope it will be as little as 5% of the rainfall; but this increases up to 50% on the steep slopes of the Tennessee River. These figures are again modified by the nature of the surface



cover. For example, on an 8% slope at Bethany, Missouri, there was about 30% surface runoff from a corn field while it was only 3.5% where the ground was planted in alfalfa.

At the same time, the soil erosion increases with the runoff; and, with the loss of soil, the land has less and less capacity for holding water. Hence the problem of floods is intimately tied up with soil erosion. Flood waters spread coarse deposits on good topsoil in the lowlands and often ruin the land for agriculture, while, by

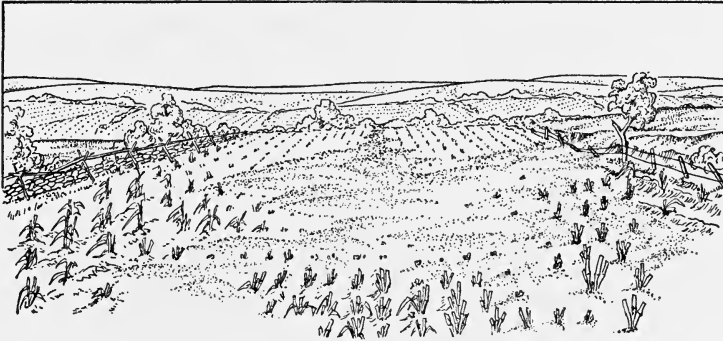

FIG. 65. Cornfield Ruined by Coarse Deposits Spread on It by a Single Rain

removing topsoil from the higher lands, they ruin that too (Fig. 65). Here and there, this topsoil may be deposited on the flood plain, increasing its fertility.

It was this fertility which probably attracted farmers to settle along the rivers. Then communities sprang up along the rivers, because of ease of transportation and water power. With the establishment of industry the railroads followed and they found it easy to build along the rivers, because the grades were gentle. And so the great cities of New Orleans, St. Louis, Louisville, Cincinnati, Nashville, and Pittsburgh sprang up on the flood plain of the Mississippi River and its branches.

## FLOOD CONTROL

★98. **Levees.** Both natural and artificial levees are satisfactory devices for preventing small, local floods. At the same time it must not be forgotten that increasing the height of the river banks in-

creases the height of the water above the flood plain, and if the levee breaks, the rush of water, and hence the damage, will be so much the greater (Fig. 66).

Levees are usually built locally, in connection with straightening of the river, to confine the water to the new channel. They should

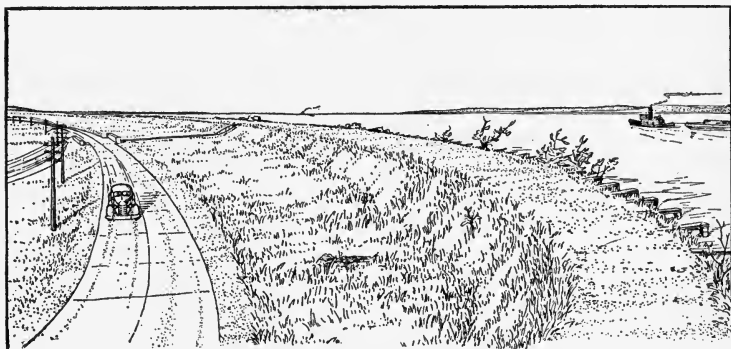

FIG. 66. A Levee on the Mississippi

not be erected too close to the stream, so that, in case of flooding, the capacity of the new channel will be sufficiently large. Local construction of levees is no real protection, for it is plain that, although the water may not overflow the levees, it can overflow where there are no levees and hence the flooding is not prevented. That being true, the false sense of security given by local levees prompts many to settle on the near-by lowlands, which, in times of unusual runoff, will become flooded.

This was well illustrated on the lower Mississippi where levees were built by individual landowners, counties, or other local organizations. Wherever the river banks were not settled, or where they were inhabited by poor or shiftless people, no levees were built and it was soon found that the levees were no protection to their prudent builders. About 1850, the United States Government undertook the control of the lower river, and in 1879, the Mississippi River Commission undertook the control of floods.

★99. **Other measures for local prevention of floods.** The meanders of an old stream have a tendency to become silted up and choked with vegetation. This will hold back the water and when the level rises, the river will overflow at such points. Clearing the

channel of debris permits the water to flow rapidly past such points and prevents local flooding to that extent, especially when the banks are also raised and reinforced.

Straightening out the meander by digging a new, straight channel will increase the velocity of flow, locally, and hence prevent flooding at this point; but it increases the height of the flood farther down the river (Fig. 67).

If to all these measures is added the building of floodways protected by levees, in order to provide an additional channel for the swollen river, the local authorities will have done all they can.

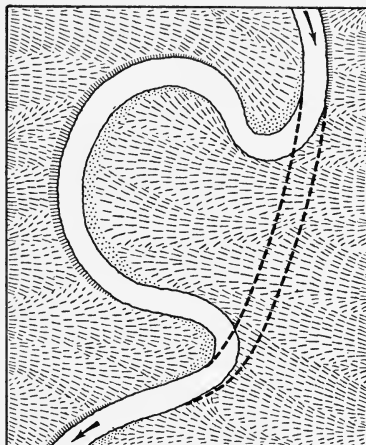

FIG. 67. Straightening a Meander

On the lower Mississippi River, in the Donaldsonville section, the levees are supplemented by spillways into the Atchafalaya River and the Bayou Lafourche to Lake Pontchartrain and the Gulf of Mexico. This outlet is a much shorter course to sea level. It therefore gives adequate protection to the river downstream and, to a limited extent, upstream (Fig. 68).

★100. **Control of floods by a national commission.** It should be apparent that floods cannot be controlled locally, and even where local measures are effective in protecting a particular community, they often increase the damage to others. Hence flood control must be undertaken by the Federal government with the cooperation of all other interested agencies. Only then can really adequate means be taken to protect life and property along a great river, if such protection is at all possible. And since this is intimately connected with soil erosion, the two problems must be placed under the control of one commission. The work of such a commission will include the following:

1. Education of the farmer in methods of soil conservation.
2. Reforestation, to provide adequate cover for the soil, particularly on hilly land.

3. Building of retarding basins or storage reservoirs.
4. Cooperation with local authorities in building and regulating levees, spillways, and floodways and in clearing and straightening channels.

★101. **Reforestation.** Where the land is hilly and the runoff rapid, there is nothing like a forest to hold the water. The ground

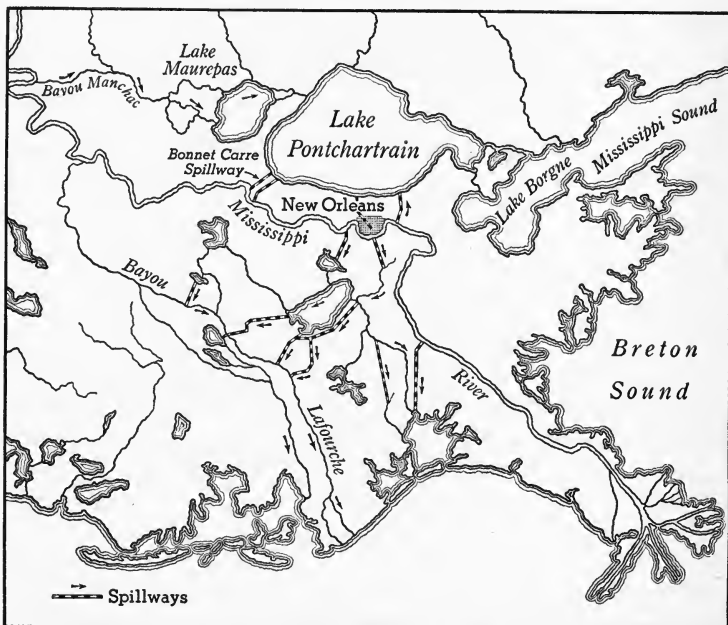

FIG. 68. Spillways on the Lower Mississippi

covered with leaves and decaying vegetation is like a sponge, while the soil is firmly held by the roots of the trees, preventing erosion. However, repeated heavy rains will finally saturate the ground and then the forest no longer retards the runoff.

Reforestation, then, is an excellent auxiliary to other devices for flood control, to say nothing of the additional supply of lumber. Such areas can be made part of our national parks and in that way be made to minister to our recreation and health.

★102. **Retarding basins and reservoirs.** The areas at the source of the river are usually hilly and it is there that reforestation is

most effective. To supplement the forests, retarding basins should be built on the river where its profile permits. A series of dams behind which the flood waters can accumulate can be built so as to retard the flow of water and prevent damage to local flood control devices farther downstream.

And finally, where feasible, large reservoirs must be built, capable of holding all the excess water. Such works are very expensive except where they can be used for other purposes, like water power, irrigation, or recreation. For example, the Wilson Dam on the Tennessee River is used for water power, while it also controls the flow of the river.

These basins tend to become clogged by sediment; but if the uplands are adequately covered by trees or grass, the soil erosion will be a minimum and this will protect the reservoir.

### ★*Completion Summary*

Floods are not very disastrous in ———, because a ——— river has ——— sides, so that the river channel can hold ———.

In ——— regions, on the other hand, where the flood plain is ——— and the population ———, a flood causes untold misery and terrific losses.

Floods are most common in spring, when ———. They are more common in regions whose soil is ———, whose slope ———, and whose surface cover ———.

The problem of floods is tied up with that of soil erosion; for the extraordinary runoff ——— topsoil from ——— and often deposits it in ——— where it benefits no one.

Sometimes coarse deposits from the uplands are ———, ruining the topsoil there, too. Occasionally the fine deposits are laid down on the flood plain, making it ———.

Levees are good ———; but natural and artificial levees may increase the disaster of a flood, because they permit more water ——— and if the levee does break ———.

Other local measures for preventing floods are ———, ———, and ———.

To be effective, flood prevention works must be under the control of ———. Besides measures already mentioned for local control, floods can be prevented by ——— and ———.

★*Exercises*

1. In what kind of region are floods frequent?
2. How does a flood in a young region differ from one in an old region?
3. Why is a flood in a young region more disastrous than one in an older region?
4. Why do most floods come in the spring?
5. Do we ever get floods in semiarid regions? Why?
6. What is the relation between floods and type of soil?
7. Show how artificial levees may be satisfactory for small, local floods, but for unusually high floods may be worse than no levees at all.
8. Discuss the relation of floods to soil erosion.
9. Discuss the protection rendered by artificial levees, touching on their control by local, state, or federal authorities.
10. What effect, on floods, has straightening a meander?
11. What are floodways? How should they be built?
12. What are spillways? In what part of a river can they be built?
13. Discuss the effect of reforestation on soil erosion and floods. On what sort of land is this device particularly needed?
14. What are retarding basins?
15. Discuss the relation between retarding basins, water power, and irrigation.
16. What danger is there to retarding basins when the uplands are not adequately covered by vegetation?

## CHAPTER IX

### GLACIERS

**103. The snow line.** In almost every part of the United States, snow sometimes falls. In the southern lowlands it may last only an hour, whereas, in some northern states, it may last all winter and entirely disappear by summer. If we go far enough to the north, we shall find snow even in the summer.

In any part of the earth, we may find snow on the mountains. Mount Washington has snow fields far into the sum-



*Diller, U.S.G.S.*

FIG. 69. The Snow Line

mer and Mt. Hood is perpetually snow capped. Even under the equatorial sun there is snow on the highest mountains throughout the year.

The lowest line in any region at which snow exists throughout the year is called the *snow line* (Fig. 69). At the equator

it is about 18,000 feet above sea level; in the northern Rockies it is about 10,000 feet; and in Greenland it is about 2,000 feet. The nearer the poles, the lower the snow line. In other words, at high latitudes, the snow line is at low altitudes. In the temperate zone, the snow line is about two miles high.

**104. How a glacier is formed.** Just as a snowball is made by compressing snow in the hands, so also the slight warmth of the sun and the pressure of successive snowfalls change the snow first into granular ice, called *névé* in the Alps, and finally into compact ice. As the weight of the ice increases, it begins to move slowly down the slope. This *moving ice is a glacier*.

The Alpine type glaciers, which move along river valleys, are called *valley glaciers*. The Aletsch and Rhone glaciers are examples of valley glaciers. We find them at the tops of all high mountains.

When several valley glaciers join together and spread out to form one continuous broad ice sheet, we call it a *piedmont glacier*. The Malaspina glacier of Alaska is of this type.

A *continental glacier* covers a great area, of continental dimensions, like the Greenland and Antarctic ice sheets. It is usually thick enough to cover high mountains: 9,000 feet in Greenland. Continental glaciers today exist only in the polar regions and in Iceland. But in the geological past, continental glaciers covered large parts of North America and Europe, and existed also in South America, Australia, and South Africa.

**105. How a glacier moves.** A piece of wax can be easily shaped by the application of pressure. Lead pipe is made by squeezing the hot but solid lead through a die. These illustrations, together with the experiment on "regelation" shown in Fig. 70, will make it easier for us to understand how a glacier moves.

It is well known that if a cake of ice is placed upon another, the two will soon become one. What has happened? When anything is compressed, it must take up less room. When



ice is compressed, it takes up less room by changing to water. If the pressure is released, however, the water will change right back to ice, because its temperature is still below freezing. When one piece of ice is resting upon another, the pressure causes it to melt, but the water formed is squeezed out from between the two pieces of ice, the pressure is diminished and the water freezes again. In the experiment on regelation (Fig. 70) the pressure of the wire causes ice, under it, to melt, and the wire sinks down under the water. Since there is no longer a pressure on the water, it immediately freezes again.

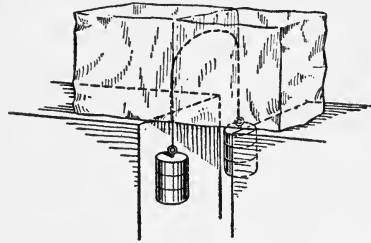

FIG. 70. Regelation

The wire passes through the ice, but the ice remains one piece.

It is by a method similar to the above that we believe a glacier moves. It does not slide downhill like a block of wood. We find it changing its shape to accommodate itself to the land over which it moves. It turns around curves in a valley, almost as if it were a liquid; it engulfs and carries along large and small boulders which it has encountered in its path (Fig. 71).

Like a river, a glacier moves more rapidly in the middle than at its sides. This has been proved by driving stakes in rows across the glacier. In time the stakes at the middle were found to be in advance of those at the sides.

Although ice will bend and twist without breaking *when under pressure*, it will crack, like other solids, when it is subjected to stresses *without pressure*. At the surface of a glacier, therefore, where there is no weight on it, the ice forms *crevasses* (Fig. 72).

As a glacier moves downward, it slowly evaporates and there comes a place where it is warm enough to melt, especially in summer. This marks the front of the glacier. Sometimes the glacier retreats, apparently moving uphill.

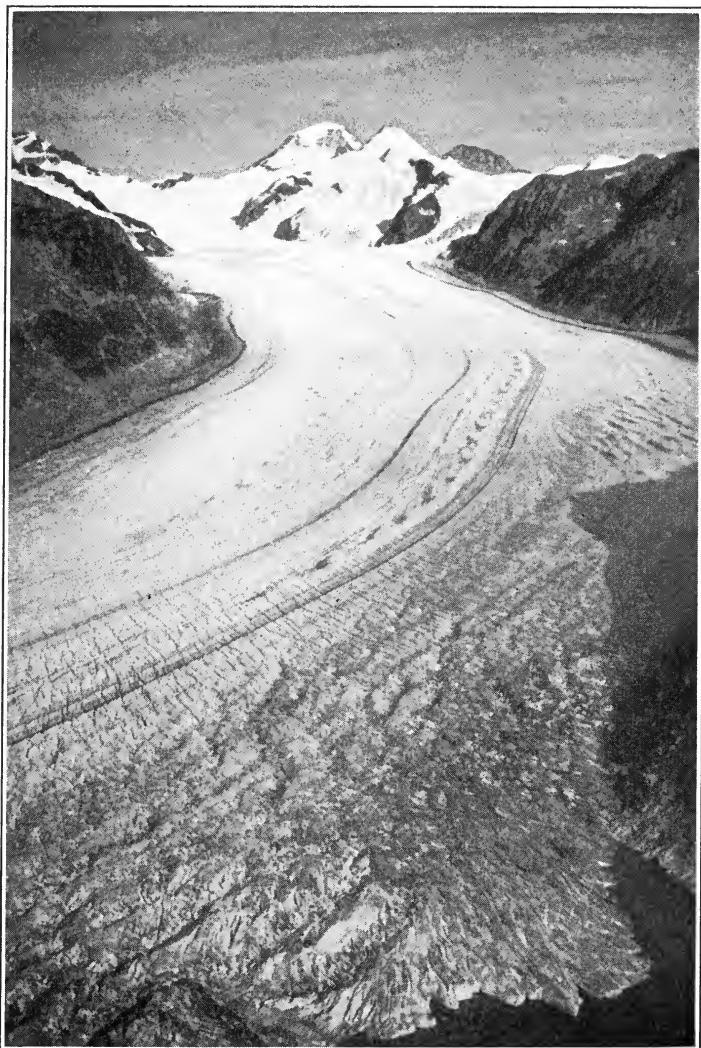

*Photograph by A. Klopfenstein, Adelboden*

FIG. 71. A glacier follows the curves of the valley.

But this is only because it is melting faster than it is moving forward. The rate of forward movement depends upon many factors: the slope, the weight of ice, the temperature, and

the irregularity of the ground. Alpine glaciers have been shown to move about one foot per day, whereas some Alaskan glaciers move about 50 feet a day.

It is easy to comprehend how valley glaciers move down the slope; but the movement of a continental glacier is not



S. R. Capps, U.S.G.S.

FIG. 72. Glacial Crevasses

well explained. One explanation has it that, as the ice accumulates in great thickness, the weight squeezes the ice along the edges at the bottom, turning it to water. The liquid escapes from under the glacier and immediately freezes because of decreased pressure. In this way, the ice front advances. In a similar way, a great mass of thick jelly poured on the middle of a table would pile up and finally begin to flow out from under, until it covered the table. If a glacier reaches the sea, as it usually does in the Arctics, it breaks up into huge floating masses called *icebergs*.

**106. Glacial erosion and transportation.** By itself, ice has very little power to erode; but pieces of rock, which it pushes and drags along, become very effective tools that convert a glacier into a huge rasp (Fig. 73).

A glacier carries its load, which is called *moraine*, in several

ways. Pieces of rock falling from a cliff onto the top of the glacier are carried along and then dropped. Shelter Rock (Fig. 74) was carried about a hundred miles, from the Highlands of the Hudson River to its present resting place

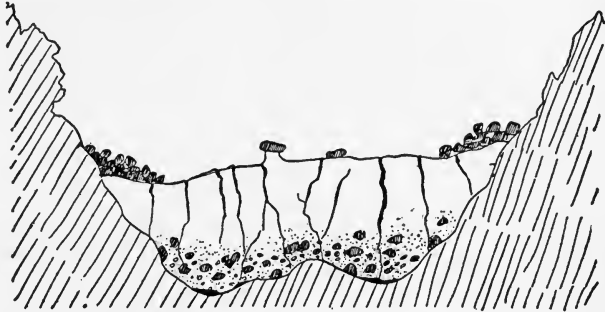

FIG. 73. Cross Section of a Glacier

Showing lateral and ground moraine, crevasses, and ice table. Walther.

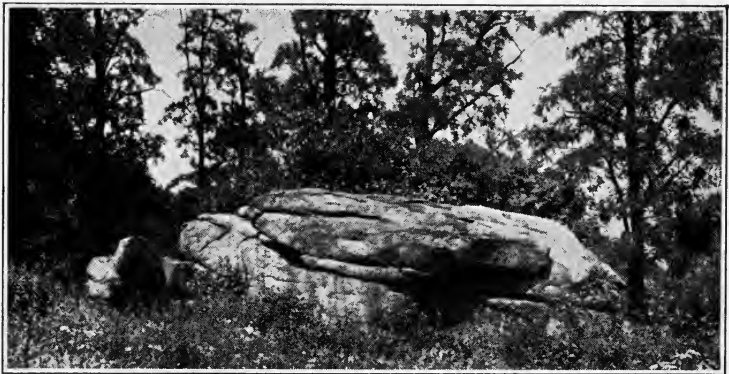

FIG. 74. Shelter Rock, Whitney Estate, Manhasset, Long Island

on Long Island. Some glaciers carry practically a forest on their backs (Fig. 75).

The glacier pushes some of its load ahead, just as a broom would. This is called *terminal moraine*. Some of it is pushed along the sides. This is called *lateral moraine*. That which is dragged along underneath is the *ground moraine*.

Boulders in the ground moraine are the chief tools of glacial erosion; and in the process, the tools themselves are marked and polished. They are not so perfectly rounded as stream-worn boulders, but faceted; that is, they have rather



FIG. 75. Malaspina Glacier in Alaska has a forest growing on it.

flat faces or facets, which are often striated (Fig. 76). These pebbles and boulders, dragged along by the glacier, make grooves in the bedrock, called *glacial striae*, which are parallel to each other because they are all in the direction of motion of the glacier.

At the same time the bedrock is smoothed on its surface and in some cases large blocks of stone are quarried out. A mass of bedrock smoothed in this way is called a *roche moutonné*. This expression means, literally, *muttoned* or *sheep-shaped rock*. In the Dolomite Alps, which have been thoroughly glaciated, glacial striae are often so numerous as to give to some imaginative observer the impression that the white rock, smoothed and rounded and streaked with glacial grooves, is a flock of huge sheep.

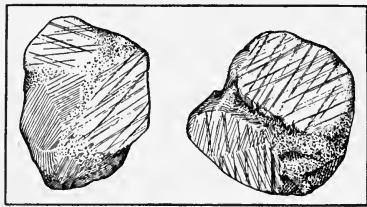

FIG. 76. Faceted Boulders, Showing Striae

If the glacier moves from north to south, then the north side of an outcrop of rock will be smoothed because the ice

rises and rides over the obstruction. But if the south end is free and unsupported, and especially if the strata project above the surface at an angle, huge masses will be broken off. Hence the south end of a *roche moutonné* often shows the effects of quarrying (Fig. 77). The Alps and the Ap-



FIG. 77. Roche Moutonné

The glacier moved from left to right. Note quarrying on the right.

palachians have been planed off by continental glaciers which rounded off the irregularities of their ridges and left many *roches moutonnés*.

*Frost action* is an important factor in quarrying, especially at the source of the glacier. During a time of melting, water runs into the joints of the rock; and then when it freezes, it expands and cracks the rock, which is then removed by the glacier. This erosion forms great amphitheater-like basins, called *cirques*, near the tops of mountains. Some of the *cirques* are afterwards filled with water, forming mountain lakes or *tarns*. The jagged appearance of Matterhorn and other Alpine peaks is due to the development of *cirques* (Fig. 78).

The water melted from a glacier in summer often finds its way into a crevasse. The eddying water whirls about, and, armed with the boulders and finer material it finds

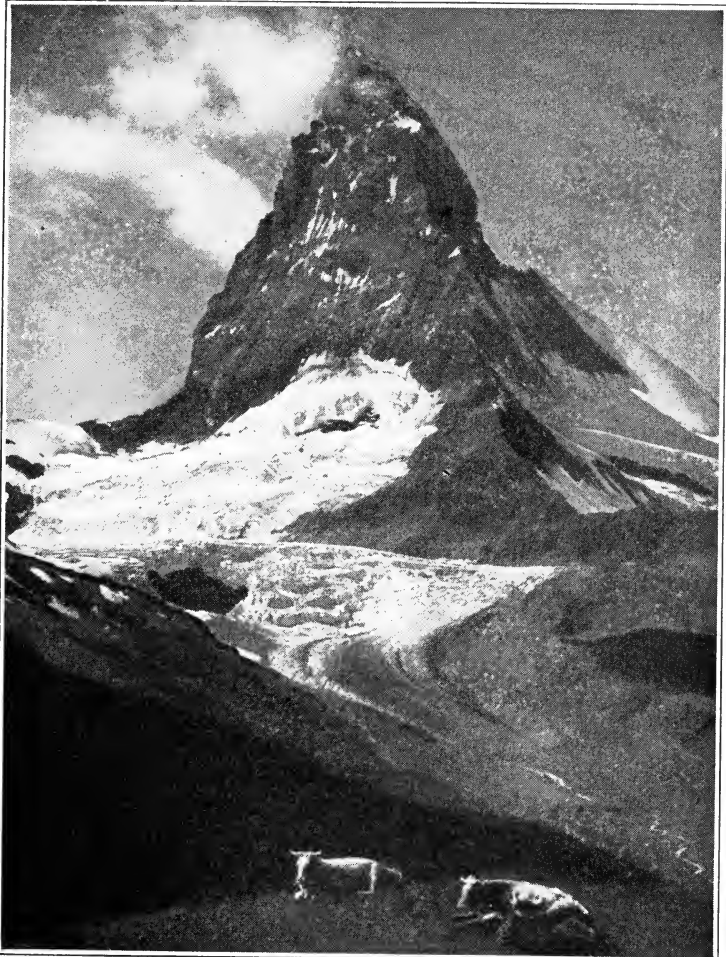

Photograph by Wehrli

FIG. 78. The Matterhorn, Showing Cirques

there, it grinds holes in the surface of the rock under the ice. These are called *potholes* (Fig. 84).

**107. The glaciated valley.** Valley glaciers ream out their valleys, and give them a U-shape. Projecting spurs of bed-rock are ground flat (*faceted spurs*) or entirely cut off, smoothing the walls of the valley and deepening the channel.

When, later, a river again flows in this channel, it is below where it used to be and its tributaries no longer join it on the same level, but remain hanging above it, forming a water-fall. Such a tributary is called a *hanging valley* (Fig. 49). In

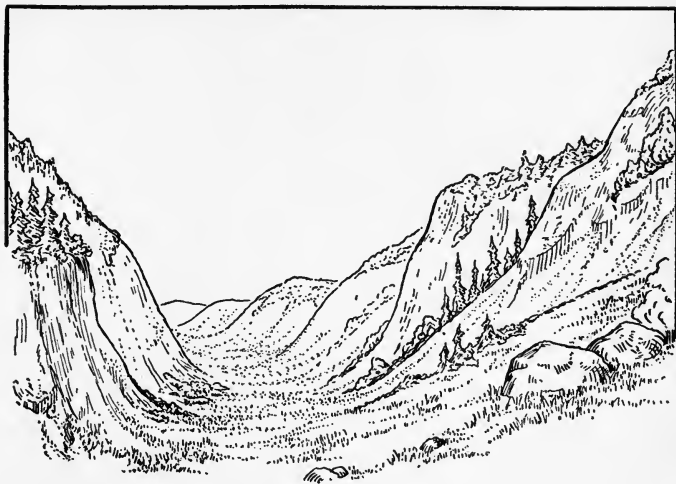

FIG. 79. A Glaciated Valley

the northern regions of the earth, where glaciers are common, most of the valleys are glaciated; hence *fiords* are common in Norway, Alaska, and Labrador.

#### CHARACTERISTICS OF A GLACIATED VALLEY

- |                          |                     |
|--------------------------|---------------------|
| 1. Cirques at its source | 4. Faceted spurs    |
| 2. U-shaped              | 5. Roches moutonnés |
| 3. No sharp turns        | 6. Hanging valleys  |

**108. Glacial deposits.** The load carried by a glacier, the moraine, is dropped wherever the ice melts. This material is not assorted, as is the waste carried by rivers, but is a mixture of large and small pieces of rock, some of them faceted, together with sand and silt — all mixed up. This is called *glacial drift* or *till* (Fig. 30). The drift deposited at the end of the glacier's movement is called *terminal moraine*.



It is easy to recognize a glacial boulder, for besides facets and striae, it is usually a different rock from that on which it rests. It is *erratic*, as we say. That is, it does not belong there. For example, on Long Island we find boulders of gabbro carried over from New Jersey. Here and there a specimen is found that hails from the Catskill Mountains. Pieces of copper ore from Michigan have been found in Missouri.

When a continental glacier melts, the great quantity of water carries away much of the finer till and deposits it elsewhere in strata of gravel, sand, and clay. *Outwash plains* are nearly level areas formed of this stratified till. Northern Long Island is almost entirely covered by a terminal moraine, while central and southern Long Island is an outwash plain, ten to twenty miles wide. Its chief characteristic is indicated by such names as Flatbush, Flatlands, and Hempstead Plains.

When a valley glacier melts, the water that flows from it is known as *glacier milk* because of the *rock flour* it contains. The mass of material soon begins to deposit in an alluvial cone, containing chiefly coarse drift. The finer material is carried farther down the valley. Such a deposit of morainal material is called a *valley train*. The very fine material is often deposited as a delta when the stream enters a lake. Some of these deposits called *varves* show alternate coarse and fine bands: the coarse layer deposited in the spring and summer when the glacier was melting, and the fine layer deposited in the winter when the glacier was frozen and the lake water was quiet. Some of the other

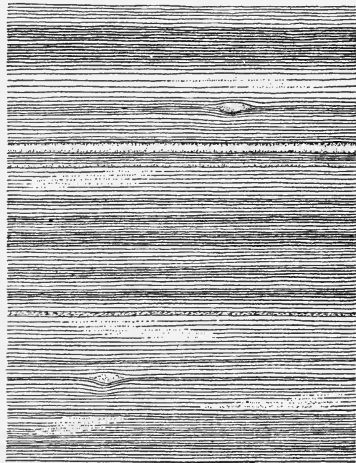

FIG. 80. Varves

forms of deposit produced by running water acting on glacial drift are known as *kames*, *eskers*, and *drumlins*.

*Kames* are more or less conical mounds of partially stratified drift deposited along the ice front by temporary streams

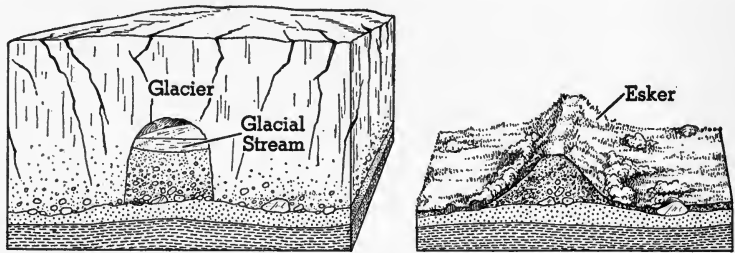

FIG. 81. Formation of an Esker from the Deposits in a Subglacial Stream

issuing from the glacier. *Eskers* are "serpentine kames." They are formed by streams which tunneled the glacier. The more or less stratified material was deposited along the bottom of the stream and when the glacier melted and the supporting walls of ice broke down, the deposit fell down too, forming a serpentine mound that looks like a railroad embankment before the tracks are laid (Fig. 81).

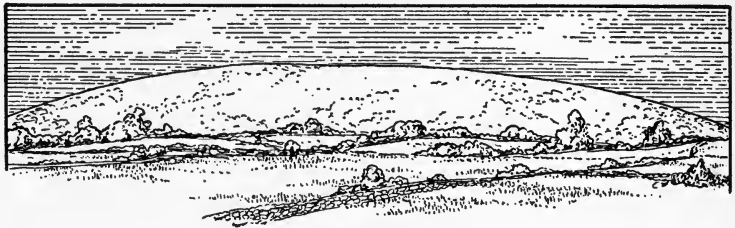

FIG. 82. A Drumlin

*Drumlins* look somewhat like inverted canoes. The axis of a drumlin is always parallel to the direction of ice movement. The word drumlin means *little hill* in Ireland. It is not definitely known how drumlins were formed, but apparently they were given their present shape by the last ice sheet that moved over them (Fig. 83).

Sometimes the morainal deposits are so close together as to give the region an undulating appearance called *knob and basin* topography. The basins or *kettles* are often filled with water. Most of the small lakes and ponds of northern United States and Canada lie in kettles. These features can be explained by assuming that the glacier broke up into blocks of ice, the crevasses were filled up by drift, and when each block of ice, surrounded by its moraine, melted, a lake was left.

Much of the discussion on glacial deposits will be understood by referring to Fig. 84.

**109. Former extension of glaciers.** It is easy to recognize a glaciated region. We observe the work of present glaciers and by those same signs we recognize a region over which a glacier has passed.

Polished and striated surfaces on the valley sides far above the present glaciers in the Alps tell us that those glaciers were once far above where they now are. A U-shaped valley,

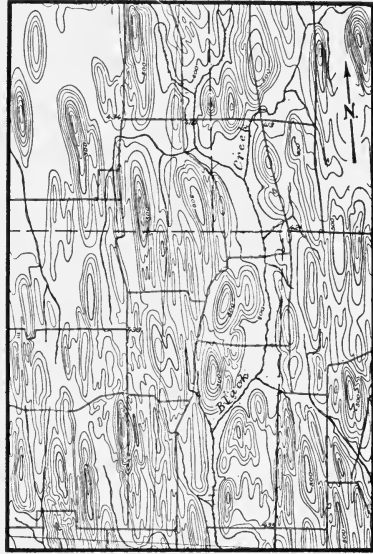

FIG. 83. Drumlins on a Topographic Map

Note how they point in a north-south direction.

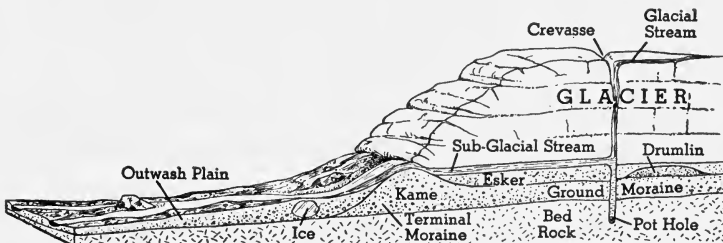

FIG. 84

in a region now far removed from glaciers, can only mean that a glacier once moved through that valley, for we know no other force which could have reamed out the valley.

Of much greater importance is the former existence of continental glaciers. The records tell us that in the not far distant geological past, about 25,000 years ago, much of North America and Europe was covered by continental ice sheets. That epoch is known as the Ice Age or Glacial Period.

**110. The Ice Age in North America.** If we travel across the United States from north to south, we are impressed by the unlikeness of the topography in the north and in the south.

In the north, the rivers are young, often with rapids and falls. Lakes are very numerous — thousands in a single state like Minnesota. The uplands are level, or if uneven, the hills and ridges are covered with a cloak of unassorted and usually coarse rock mantle. Numerous boulders, wholly different from the bedrock, are widely scattered. The mountains have numerous lakes and swamps in their valleys. The soils are all *transported*, being entirely unlike those formed from the bedrock.

In the south, the rivers of the upland are mature, having long ago removed their rapids and falls. There are no lakes or swamps in the mountains or in the uplands; and the uplands are hilly and cloaked with *residual* soils.

The line which separates these two types of topography follows roughly the Missouri and Ohio rivers to their sources in the Rocky Mountains and in southwestern New York; thence westward by an irregular line to Puget Sound and eastward and southeastward to the east end of Long Island, touching approximately these large cities: Boston, New York, Cincinnati, St. Louis, Omaha, and Seattle.

★**111. Causes of the glacial period.** There has been much speculation regarding the causes of glacial epochs, but it seems clear that no single cause is sufficient to account for the facts. Most glacial periods in geological history have occurred when the

continents were elevated. If the land were raised about two miles anywhere in the temperate zone, that region would undergo a glacial epoch. But this hypothesis is insufficient, of itself, to account for the repeated glacial and interglacial epochs of the Pleistocene Period.

Another theory concerns the amount of water vapor and carbon dioxide in the air. These two constituents of the air act like a

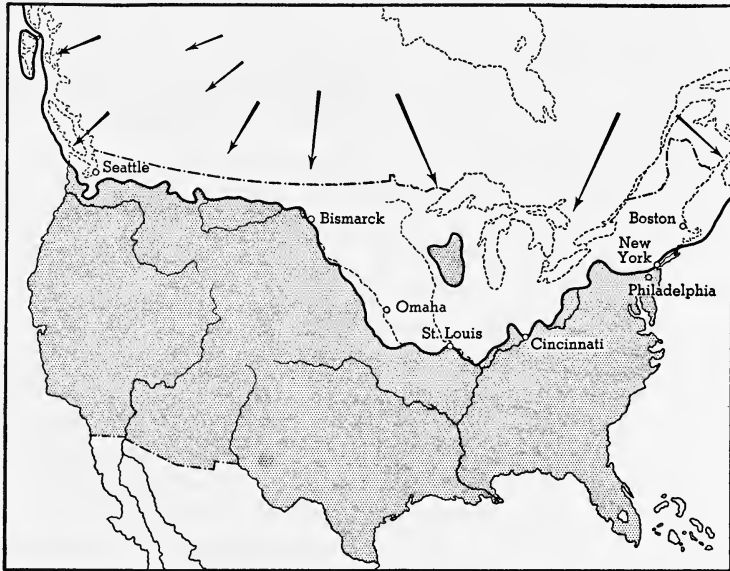

FIG. 85. Southern Limits of the Ice Sheet That Covered Northern North America During the Glacial Epoch in the Pleistocene

The arrows show the directions in which the ice moved.

blanket over the earth, preventing it from losing its heat rapidly. The sea water contains much more carbon dioxide than the air and the colder the water the more gas it will dissolve out of the air.

If, then, the land is uplifted a little, it gets colder; the waters dissolve more carbon dioxide out of the air, making it still colder, and a glacial period develops.

A slight rise in temperature would cause the sea water to give up its carbon dioxide to the air, the earth would be blanketed, it would get warmer, and the *interglacial* epoch would appear.

But how get the increased heat? At present our winter occurs when we are three million miles nearer the sun than we are in summer. The shape of the earth's orbit changes, becoming less nearly a circle, and the position of the earth's axis changes too, so that there comes a time when we are *farthest* from the sun in winter, and hence our winter is longer than our summer. This hypothesis makes our glacial epochs the result of long aphelion winters.

According to this hypothesis, glacial conditions now exist in the southern hemisphere; and the fact that the only extensive land area in the antarctic regions is covered by a thick sheet of ice seems to support this hypothesis.

★112. **Retreat of the ice sheet.** As the ice sheet moved down from the north, it invaded a region probably as maturely dissected as Kentucky and Tennessee now are. River systems were widely branching and lakes had disappeared. When the ice began to melt, the ice front retreated and revealed a land with completely changed surface. Ridges were planed down, the surfaces of bed-rock gouged out to form long parallel grooves (glacial striae) which show the direction of movement, and valleys partially or wholly filled up with drift. Wherever the glacier paused for a time in its retreat, a terminal moraine was formed. If the ice advanced for a season, former moraines were obliterated and new ones deposited when once more the glacier retreated. The ice sheet did not advance and retreat uniformly along its entire front, and records of these irregular movements can be found between the Ohio River and the Great Lakes, where we find many terminal moraines which are roughly parallel to each other (Fig. 86).

In melting, the ice often left great erratic boulders perched in unstable positions (Fig. 87). They are called *perched boulders*, *erratics*, and sometimes *rocking stones*.

By overrunning older ground moraine, long canoe-shaped hills called *drumlins* were fashioned. The formation of drumlins may be likened to the leaving of pointed strips of packed snow, when wet snow is swept from the pavement.

The glacier in its advance swept the loose mantle from the surface wherever it was high and smooth, and filled in the low and irregular places. The effect of this was to flatten out the land, making it gently undulating (Fig. 88).

★113. **Effects of the ice sheet on drainage.** The smoothing and

flattening of the land reduced the gradient and made all streams sluggish. The great masses of morainal material, dumped all over

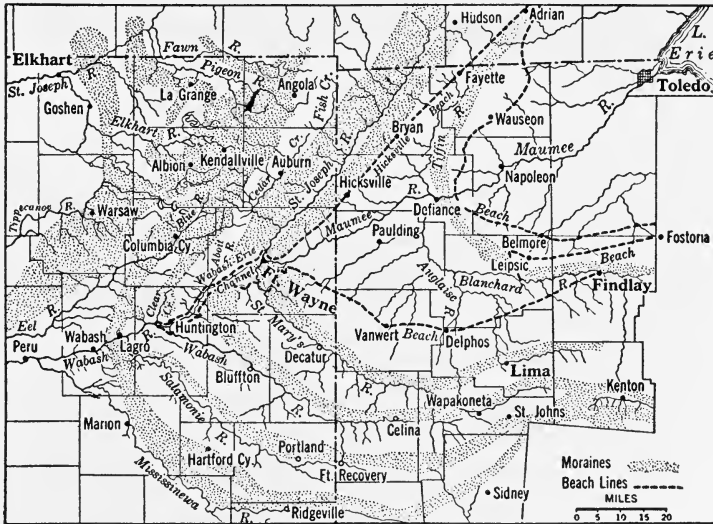

FIG. 86. Map of Erie Moraines

the land, dammed up rivers and formed lakes. Old streams were gouged out, making them deeper, but many new streams were formed on the surface of till. These streams carried large volumes of water from the melting ice — much larger than they have ever had to carry since then; and we find that many of the rivers of the glaciated region occupy valleys apparently too large for them.

As the ice sheet advanced, it smoothed out the surface, but as it receded, the moraines formed an irregular surface called *kettle moraine*. Many of the kettles were filled with water. Those that were very shallow soon became choked up with vegetation. In this way the numerous high-level marshes of northern United States and Canada were formed.

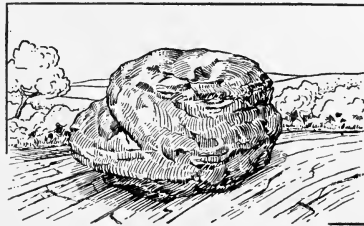

FIG. 87. A Perched Boulder or Rocking Stone

★114. **Formation of the great lakes.** Rivers that flowed north, like the Red River, were dammed by the ice to form lakes, and the volume of water from the melting ice was so great that these lakes

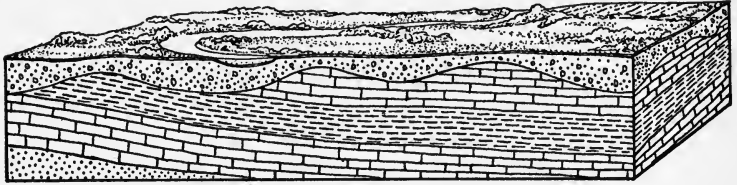

FIG. 88. Glacial Drift Filling Depressions and Making the Surface Flatter

occupied very extensive areas. The one formed in the valley of the Red River, of which the present Lake Winnipeg is a remnant, is called glacial Lake Agassiz. *It was several times the size of our present Lake Superior.* With the passing of the glacial epoch it was drained, and its silt-covered bed is now one of the greatest wheat-

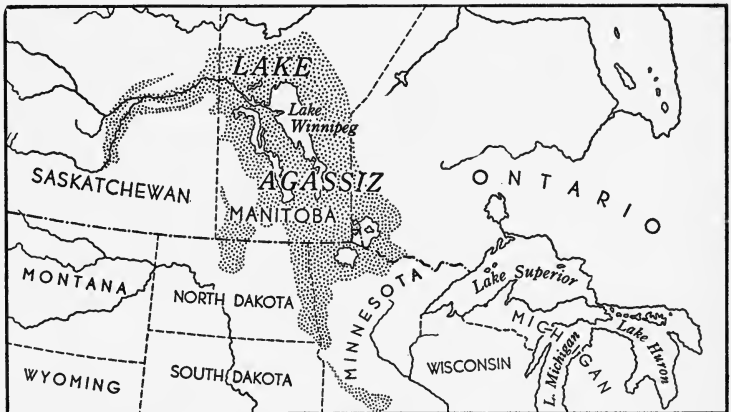

FIG. 89. Glacial Lake Agassiz

producing regions in North America. These lakes drained into the Illinois River, past Chicago, but later they found a lower outlet into the Mohawk River, which emptied into the Hudson River at Little Falls, New York. When, however, the ice-dammed St. Lawrence valley was cleared, the drainage found its present course (Fig. 90).



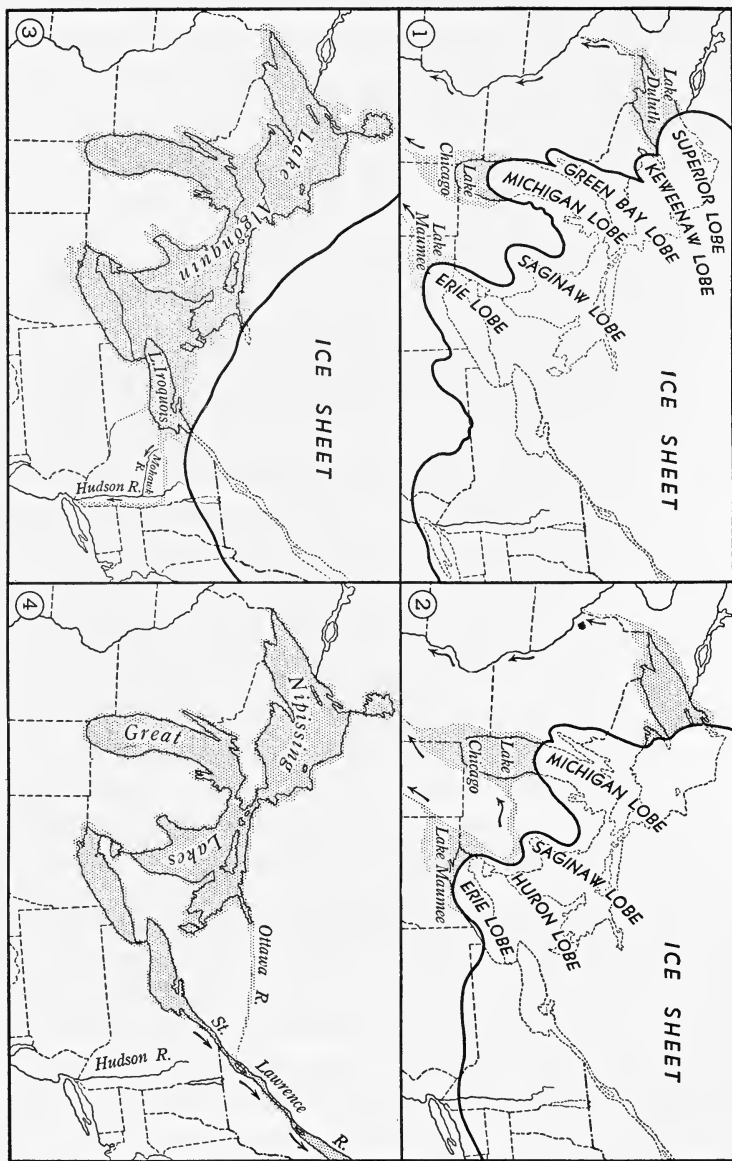

FIG. 90. Formation of the Great Lakes from the Melting Continental Glacier

The Great Lakes, in other words, occupied what were probably preglacial river valleys. At first, the vast amount of water produced by the melting ice flooded the region, and for a time there was one vast lake. Then as the ice-dammed rivers were opened up, this lake was tapped and as its water dropped in height, the several lakes took their present form. The margins of these older lakes have been traced by their beaches and other shore-line features.

Other large lakes, like the Finger Lakes of New York and most of the lakes of northern New York and New England, occupy basins produced by glacial drift, which dammed up ancient river valleys sufficiently to hold back the water formed by the melting glacier.

**115. Economic importance of glacial drift.** The presence of vast deposits of glacial drift in northern United States has played an important part in determining the lines of its economic development. The general result of the deposition was to leave this region more nearly level than before the coming of the glacier. This has favored the building of roads and railroads, which in turn promoted commerce.

A thicker covering of rock mantle is found in the glaciated than in the unglaciated regions, and this favors the more even and constant flow of rivers. The numerous lakes also help to equalize the flow of streams, making transportation by water possible. River transportation in the south is very limited, whereas in the north, the lakes, the rivers, and the canals make carriage by water of importance, because it is very cheap.

The soils of the north and south are very different. In the northeast, the soils are coarse and sandy and the surface is cumbered with glacial boulders. Farther west, the soils are of a finer texture, free from boulders, and very productive. It is probable that the difference in the character of the crops raised in the two sections, north and south, is due rather to difference of climate than to difference of soil.

Clay, sand, and gravel are obtained from glacial deposits. The clays are used in the manufacture of bricks, tile, and

earthenware. Sand is used in making glass, in building, and in many industrial enterprises. Gravel is used to make concrete.

### *Completion Summary*

There is always snow above \_\_\_\_\_.

A valley glacier \_\_\_\_\_ river \_\_\_\_\_; while a continental glacier overrides \_\_\_\_\_.

A glacier moves on a layer of \_\_\_\_\_, formed by pressure of \_\_\_\_\_.

A glacier carries rocks on top, \_\_\_\_\_, and \_\_\_\_\_. The glacial load is called \_\_\_\_\_. The ground \_\_\_\_\_ is the chief tool of erosion. Boulders grind and smooth off surfaces into \_\_\_\_\_. Grooves called \_\_\_\_\_ are worn into the bedrock. The direction of these grooves tells us \_\_\_\_\_ glacier.

When the ice begins to melt, the water \_\_\_\_\_ boulders, and \_\_\_\_\_ potholes.

A glaciated valley has \_\_\_\_\_ walls, has \_\_\_\_\_ shape or profile and its tributaries join \_\_\_\_\_ waterfalls. It is \_\_\_\_\_ hanging valley.

Glacial \_\_\_\_\_ is unassorted. It usually \_\_\_\_\_ erratics, or specimens of rock \_\_\_\_\_.

When the glacier melts, it deposits \_\_\_\_\_ in irregular piles. The end of the ice sheet is marked out by \_\_\_\_\_ moraine.

Running water works over the moraine and forms mounds of various shapes. These are called \_\_\_\_\_, \_\_\_\_\_, and \_\_\_\_\_.

Kames are \_\_\_\_\_ stratified mounds of \_\_\_\_\_, irregularly \_\_\_\_\_ in shape. \_\_\_\_\_ are kames that have been \_\_\_\_\_ by streams in and under the ice. They look like \_\_\_\_\_.

Drumlins are shaped like \_\_\_\_\_, each one with its axis \_\_\_\_\_ in which the glacier moved.

About \_\_\_\_\_ years ago, the northern part of Europe and North America was \_\_\_\_\_ ice sheet. The glacier \_\_\_\_\_

from the north, smoothing off ———, deepening and grinding ———, carrying soil and loose boulders from ——— to ———, where the moraine was deposited.

★The causes of the glacial period are not fully understood. One theory ——— elevation above the snow line. Another theory starts with a slight uplift which makes the temperature ———. Colder water ——— more carbon dioxide, removing it ——— air. Both moisture and carbon dioxide having been removed from the air, the earth loses ——— by radiation and it gets ——— until ——— glacial epoch. This cycle of changes would reverse itself, if the temperature ——— slightly.

The movement of the continental glacier changed ——— northern United States. The surface was left ———, valleys were ———, many new lakes, like ———, were formed.

### *Exercises*

1. What is the snow line? How high is it in the United States?
2. How does a glacier form?
3. What are valley glaciers? Name one.
4. What is a piedmont glacier? Name one.
5. What is a continental glacier? Name one.
6. How does a glacier move around a curve?
7. Where are crevasses formed?
8. What is meant by the retreat of a glacier?
9. How are icebergs formed?
10. What are the tools of glacial erosion?
11. What is moraine?
12. State several ways in which a glacier transports material.
13. What is a terminal moraine?
14. What is a lateral moraine?
15. What is ground moraine?
16. What is a faceted boulder?
17. What are glacial striae?
18. What is a roche moutonné?
19. Explain how frost action produces a cirque.
20. What is a tarn?
21. How are potholes formed?
22. What is the profile of a glaciated valley?

23. What is a hanging valley?
24. Where are fiords commonly found? Why?
25. Explain how faceted spurs are formed.
26. What are the characteristics of a glaciated valley?
27. What is glacial drift?
28. What is an erratic? Give an example.
29. How are outwash plains formed?
30. What is glacial milk?
31. What is a valley train?
32. How are varves formed?
33. What are kames?
34. What is an esker?
35. What is a drumlin?
36. What is meant by knob and basin topography?
37. In what ways does the topography of the north differ from that of the south?
38. Name five cities which are nearly at the southern limit of the great continental ice sheet that covered northern United States in the Glacial Period.
39. What effects has the continental glacier had on commerce in northern United States?
40. In what way do soils of the north differ from those of the south? Why do we find stone walls used to mark out fields in New England and not in Virginia?
41. Why do we find many lakes in Wisconsin, Minnesota, and New England, and none in Kentucky, Tennessee, and the Carolinas?

**★Optional Exercises**

42. Explain regelation and apply it to the movement of a glacier.
43. How does a continental glacier move?
44. Why are cirques formed only near the source of the glacier?
45. Would a glaciated valley look young or mature? Discuss. Does glaciation have any effect on the cycle of stream erosion?
46. How are kettle lakes formed?
47. What evidence have we that glaciers once covered much of Europe and North America?
48. What relation exists between elevation and a glacial period?

49. Discuss the effect of changes in the carbon dioxide and water content of the air on a glacial epoch.

50. What are perched boulders?

51. Why are glaciated valleys in the region of the continental glacier apparently too large for the present streams?

52. How did the continental glacier affect the drainage of northern United States?

53. What was glacial Lake Agassiz?

54. Why were rivers that flowed north dammed by the ice sheet?

55. How were the Great Lakes formed?

56. Where did they drain at first? Why?

57. Why did they change their outlet?

## CHAPTER X

### THE GROUND WATER

**116.** In previous chapters we considered the effects of running water — of that part of the rainfall which runs over the surface into rivers, and finds its way to the sea. Now we shall take up the study of that part of the rainfall which sinks into the ground. The percentage of the rainfall which supplies the ground water depends upon the temperature and dryness of the air, which control the rate of evaporation; upon the slope of the land; upon the nature of the surface cover; and upon the porosity of the mantle and bedrock.

Loose mantle may contain as much as 30% water by volume, sandstone about 15%, shale about 5%, and igneous rock about 1%.

In the study of soil erosion it was shown that the surface runoff from sloping ground planted in corn was much greater than from similar ground covered with grass.

**117. The water table.** In moist regions the rain usually wets the soil as far down as it is porous and then accumulates on the first impervious layer (Fig. 91). Near the surface the soil is not soaked or saturated with water but it is moist or damp because the *surfaces* of the grains of sand and clay are wet. It is important that the *spaces between particles*, in this region of vadose water, are filled with air. If they are filled with water the soil is not fertile. It is this moisture, called *vadose water*, which plant roots absorb; and the capillary action of clay, due to its enormous surface, is continually drawing water up against the force of gravity.

Farther down the water collects over a layer of impervious rock and wets the soil thoroughly so that there are actual *drops of water between the grains*. This is *ground water*. The

line separating the zone of vadose water from that of ground water is called the *water table* (Fig. 91).

In general the water table is more or less parallel to the surface of the ground, but if the ground slopes, or at least,

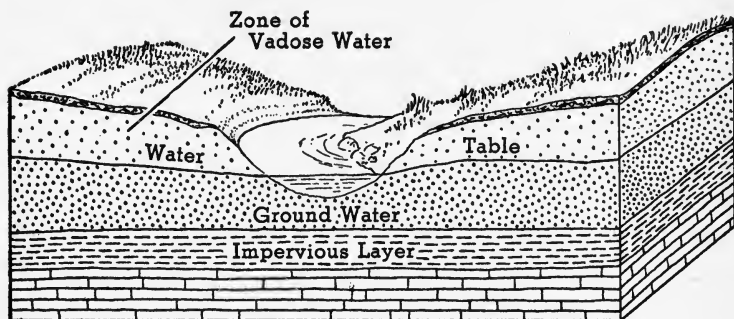

FIG. 91

if the impervious layer slopes, then gravity will cause the water to move down toward lower levels, but it will move very slowly. If there were no movement, the water would be level; if movement were quite free, as it is on the surface,

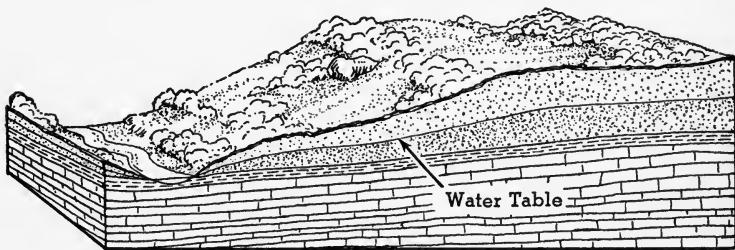

FIG. 92. Water Table on Sloping Ground

the water would be parallel to the surface, but actually it is in between these two positions (Fig. 92). Wherever the water table intersects the surface, a body of water will collect: a spring, a pool, a lake, a swamp, or a river.

Sometimes the impervious rock has unusual shapes, and therefore the water table will be unusually irregular and fan-



tastic. Figure 93 shows a "perched water table" caused by such a condition.

The water table is not fixed in its position but varies greatly. When it rains, the water table rises; during periods of drought, it falls and tends to become level. When a gully cuts into a hill, it frequently taps the ground water and the water table falls. It can, from this cause, fall so low that the piece of ground is made useless for farming.

Surface waters have been found in rocks as far down as two miles; this is due, no doubt, to cracks rather than porosity. But it seems hardly possible that water can pene-

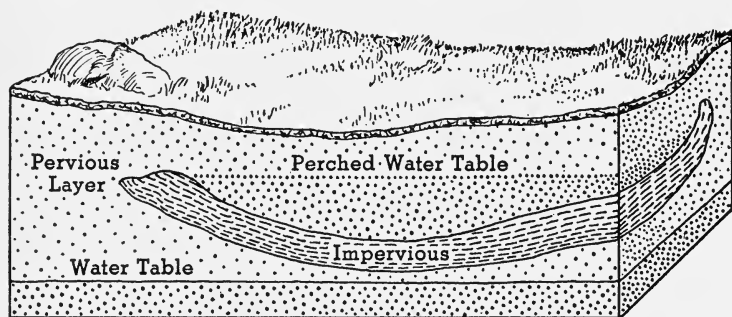

FIG. 93

trate much farther than that, because, with the great pressure of the overlying rocks, it has been calculated there can be no cracks or pores in rocks at those depths.

**118. Relation of water table to agriculture.** The variation in the level of the water table has a marked influence upon the usefulness of the region for agriculture. If the water table is above the surface, ponds and lakes are numerous; if it is at or near the surface, swamps and marshes occur. Some of these wet lands can be reclaimed by draining.

Much of the land now under cultivation is too wet to give a good yield. When the ground is soaked, air cannot penetrate the soil and it becomes infertile.

If the water table is too high, the surface is continually wet. Minnesota is said to have 8,000 lakes, Connecticut has

about 1,500, and in general the northern states, east of the Mississippi, have much of their surface covered with water. Shaler says there are 64 million acres of swampland east of the Appalachians that can be reclaimed. In addition, large areas on the flood plains of old rivers, like the Mississippi, are swampland, at present useless. One sixth of the entire state of Arkansas is in this condition. When these lakes and swamps are drained, the reclaimed land will be very fertile.

In Holland, it is prescribed that on pasture lands, the water table shall be kept  $1\frac{1}{2}$  feet below the surface; and that on land used for general farm crops, it shall be kept  $2\frac{1}{2}$  to  $3\frac{1}{2}$  feet below the surface.

If the water table is low, agriculture is impossible unless water can be obtained for irrigation.

**★119. Irrigation.** There are a few regions where the water table is so near the surface that crops do not depend upon local rainfall.

The sections of Holland that have been reclaimed are probably the most important region of this type. A few other regions situated on flood plains have similar advantages.

For many centuries, man has raised farm crops in arid regions by the aid of irrigation. The early Egyptians pumped water from the Nile as early as 3400 B.C. The ancient civilizations in the valley of the Tigris and Euphrates also depended upon extensive systems of irrigation. In the Americas it was first practiced by the Indians of Arizona and New Mexico and by the ancient Peruvians and Bolivians.

Irrigation systems cost large sums of money, but when completed, they bring two important advantages: an increase in the value of the land and an increase in the number of people who can make a living from the land. In Oregon, some very cheap land was changed, by irrigation, to orchards worth \$1,000 an acre. In some of the well-developed irrigation districts of China and America, as many as 500 people per square mile have been able to live on the land.

There are about 170 million acres under irrigation throughout

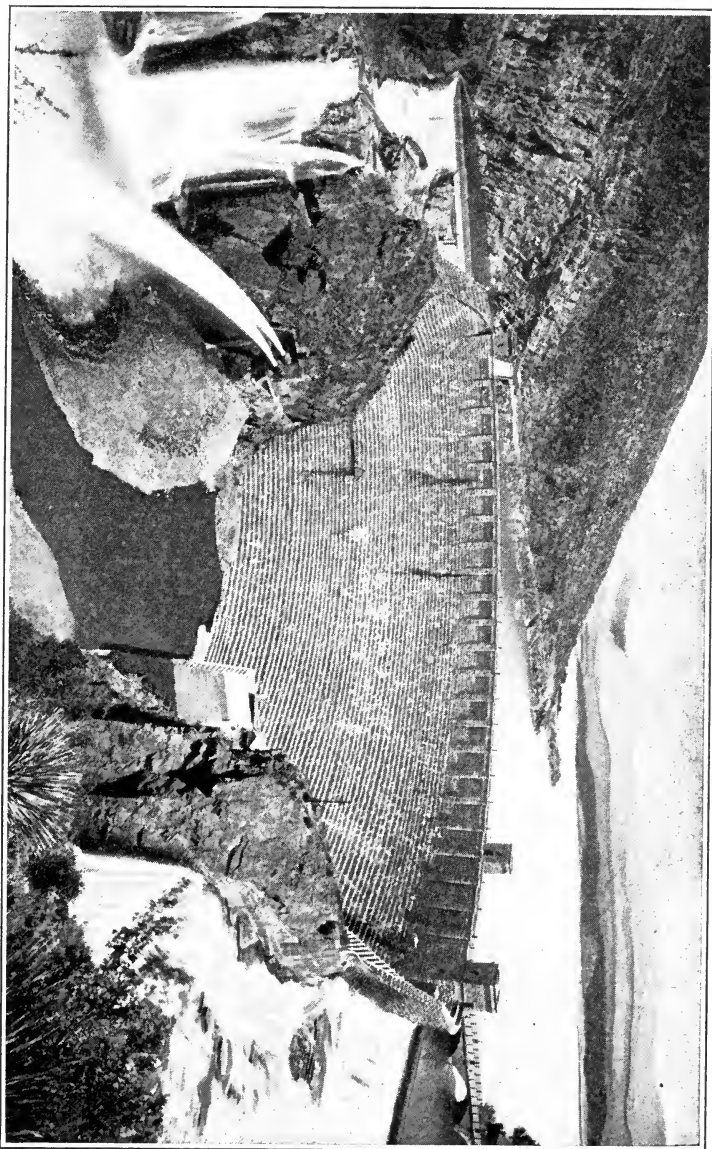

FIG. 94. Roosevelt Dam

*Courtesy of the U. S. Reclamation Service*

the world, the largest area in India, 50 million acres, and the next largest area in the United States, 20 million acres.

The Roosevelt Dam, built across a canyon in the Salt River of Arizona, forms a lake with an area of 25.5 square miles. It is esti-

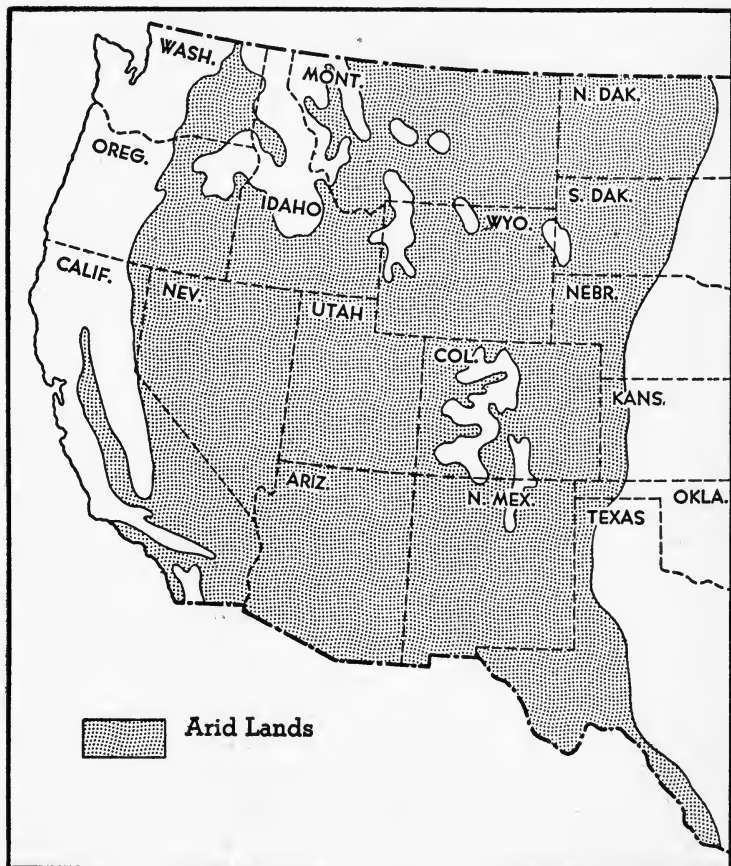

FIG. 95

mated that the water in this great reservoir will irrigate 300 square miles of farm land.

About four tenths of the United States is too dry to produce crops without artificial watering, since the entire annual rainfall is sufficient to irrigate only about 10% of the arid land. Most of these

lands are in the west, but even in the east there is much land that could profit by irrigation. The capital investment is about \$36 per acre, cost of preparing the land \$18 per acre, and the value of the annual crop \$41 per acre.

The program of the United States Reclamation Service contemplates placing about 45 million acres of land under irrigation, an area capable of supporting 45 million inhabitants.

Some of these irrigation projects, like that at Boulder Dam, were undertaken for several purposes — water supply, water power, etc. — and many of them in the near future will be entered upon in connection with flood control.

★120. **Dry farming.** In its literal meaning, dry farming means farming without water, which is absurd. The expression has come to mean farming in arid or semiarid regions without irrigation, by methods that preserve the limited rainfall for use during the growing season. A layer of dry dust called *dust mulch* is formed over the cultivated land in order to prevent evaporation of water, and in this way the water is stored in the soil for a year or more, so that a crop can be produced, perhaps, every other year.

Dry farming has resulted in almost complete depopulation of the lands so cultivated, since most of the enterprises have failed. It has, moreover, resulted in dust storms and soil erosion from wind and water, causing destruction of the agricultural lands on a grand scale.

121. **Wells.** If a hole is dug below the water table, water will run into it and any water drawn out will be replaced as long as the water table remains above the bottom of the hole. Such a hole is an ordinary *well* (Fig. 96). *B* is a permanent well because the water table never drops below its bottom, while *A* is a temporary well, since in dry weather the water table is below it. Since it has become known that typhoid fever, diphtheria, and cholera are transmitted by drinking water, laws have been passed by the legislatures of many states to protect the water supplies of the cities. But about three quarters of the population of the United States depends for its drinking water upon wells, and it seems certain that thousands of deaths and innumerable cases of disease owe their origin to contaminated well water.

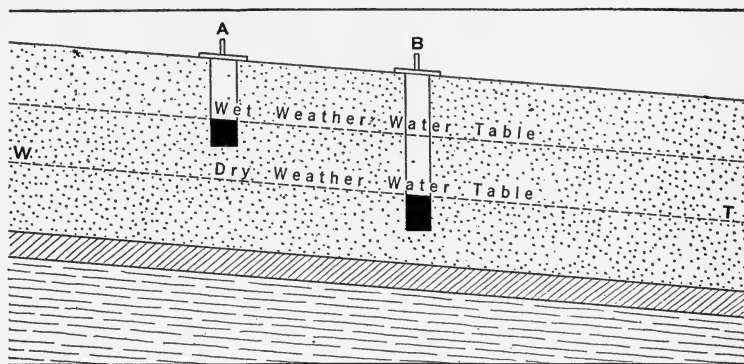

FIG. 96. Temporary and Permanent Wells

An examination of a large number of farm wells in one of our western states showed that about three quarters of all the wells less than 25 feet deep, and half of those between 25 and 50 feet deep, contained germs of one or more of the diseases mentioned, whereas only one eighth of those between 50 and 100 feet deep were contaminated, and every well over 100 feet deep yielded pure water.

The average well is a hole in the ground covered with planks. Chickens and geese walk over these planks and contaminate them. The pumped well water runs over, cleans the planks, and drips back into the well. There is often a trough under the pump spout, where horses, pigs, and cows come to drink. The filth that they leave near the well is often washed into the well by the rain.

The principal sources of contamination of wells are: surface water, manure heaps, sewers, cesspools, barns, chicken coops, hog pens, laundry drains, swamps, gas works, slaughter houses, starch works, and certain other industrial plants.

**122. Proper location of wells.** Wells may be unsanitary because of improper location with respect to the flow of ground water from sources of contamination, or because of improper construction.

In porous soils the flow of ground water is almost parallel

to the slope of the ground. Hence the well should be located *above* all possible sources of pollution (Fig. 97). There are cases where the flow of ground water is not parallel to the

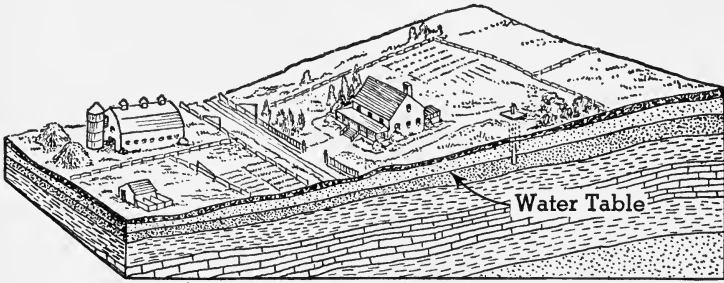

FIG. 97. Wells should be placed above all sources of pollution.

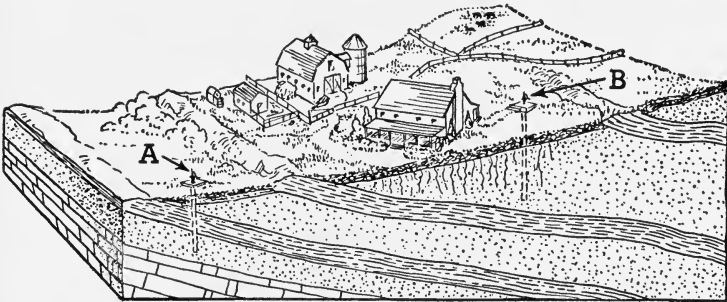

FIG. 98. Where should the well be located: at A or at B?

surface, however (Fig. 98). In such a case the usual rules cannot be followed, and it is essential to get expert advice before locating the well.

**123. Construction of wells.** A type of well that has proved very satisfactory is shown in Fig. 99. It is lined with brick or stone, laid in cement. It has a cement or stone top, with an iron manhole on it. An apron of cement with a radius of about ten feet surrounds the well, and a tile drain carries away the waste water.

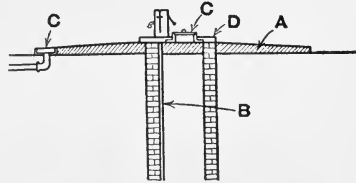

FIG. 99. The Mason Well

The following general laws of sanitation of wells should never be violated:

1. Locate a well so that the natural flow of the ground water cannot bring filth into it from any source whatever.
2. Construct a well so that no water can get into the well at any point above the water table.

**124. Artesian wells.** In some deep wells, the water rises to the surface and overflows or is projected into the air (Fig. 100). The first well of this sort seems to have been located at Artois, France, and all wells like those at Artois are called *artesian*.

The pressure which is responsible for the flow of artesian water owes its origin to the collection of water in a porous layer surrounded by two impervious layers (Fig. 101). Rain-fall over the collecting area sinks into the porous rock, called the *aquifer* (water-bearing rock), in which it is trapped by the impervious layers above and below. If the aquifer is tapped anywhere below the water table, water will flow out under the pressure of the water above it. It should be noted, however, that an artesian well does not depend for its supply of water upon the local water table, but upon a distant water table.

These aquifers are usually sandstone or loose beds of sand. Artesian wells are common on the Atlantic Coastal Plain from New York to Texas because of the presence of underlying loose sands. Underlying the middle western states there are several aquifers which can be tapped for artesian water, but in New England and eastern Canada there is no possibility of artesian wells, because of the presence underneath of metamorphic rocks. Boise City, Idaho, Memphis, Tennessee, San Antonio and Houston, Texas, and Brooklyn, New York, are a few of our great cities that have artesian well-water supply. Some of these wells are as much as 4,000 feet deep.

Artesian well water is usually of exceptional purity, because the impervious layers keep surface impurities out,





*N. H. Darton, U.S.G.S.*

FIG. 100. Artesian Well at Lynch, Nebraska

Flow, 60 barrels a minute.

while the great depth of the well insures thorough filtering of the water.

**125. Springs.** Wherever the water table intersects the

surface, water comes out of the ground (Fig. 91). If the water flows out in a current it is called a *spring*.

*Fissure springs.* Ground water frequently comes to the surface through a fissure in the bedrock, forming a *fissure*

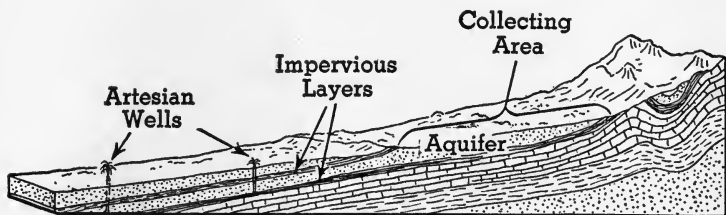

FIG. 101

*spring* (Fig. 102). The structure of such a spring is practically identical with that of an artesian well, except that the spring is natural, while the artesian well has to be drilled.

The water from fissure springs is usually wholesome, like

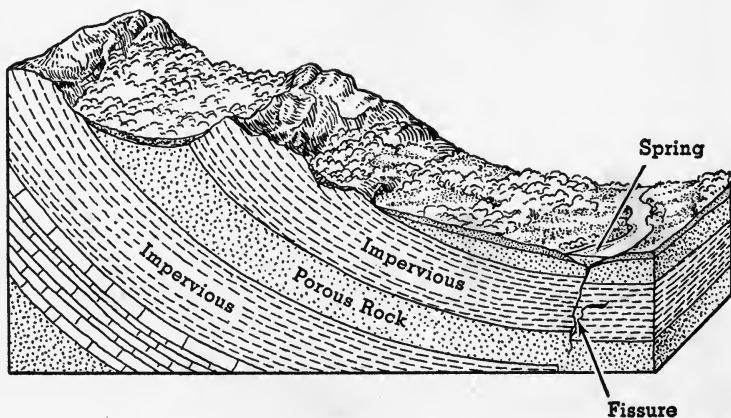

FIG. 102. A Fissure Spring

artesian well water. It is usually rather cold, because it comes from great depths where the sun's heat does not penetrate.

*Mineral springs.* Certain springs, like those at Saratoga, New York, and Vichy, France, contain carbon dioxide in

solution, which causes them to effervesce, or bubble, as the water flows from the spring. Others, like the White Sulphur Springs of Virginia, the Fountain of Youth in Florida, and those near the Finger Lakes in New York State, contain hydrogen sulphide, an ill-smelling gas, in solution.

Nearly all springs, coming from deep sources, contain much dissolved mineral salts which give the water medicinal properties. Among these salts the most common are sodium chloride and sulphate, calcium sulphate and bicarbonate, magnesium sulphate, chloride, and bicarbonate, and iron bicarbonate. These salts have undoubted effects on the body, but their curative properties are very much overrated and they should not be taken in quantity without the advice of a physician.

**Hot springs.** The heat of some spring waters is probably due to their contact with heated rock, since most hot springs occur in volcanic regions, near Fujiyama in Japan, near Vesuvius in Italy, near Lassen Peak in California. There are great springs of boiling water in Yellowstone Park and in Arkansas and other regions showing evidence of volcanic activity in the past.

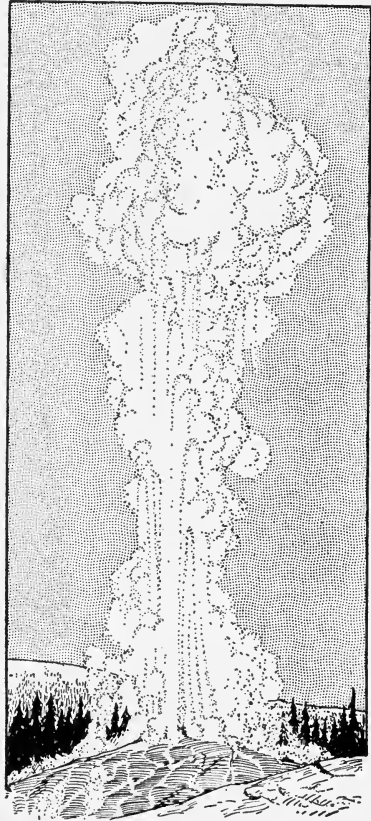

FIG. 103. A Geyser in Action

★126. **Geysers.** A gushing hot spring in Iceland is called a *geysir*. The Giant Geyser of Yellowstone Park throws a column of

hot water 250 feet high and continues for an hour or more. Some geysers are irregular but most of them discharge regularly. Old Faithful in Yellowstone Park erupts every 65 minutes. Geysers occur in Yellowstone Park, Iceland, and New Zealand (Fig. 103).

The action of a geyser depends upon the effect of pressure on the boiling point of water. Water at atmospheric pressure boils at

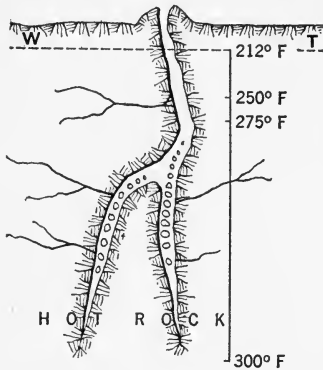

FIG. 104. Diagram of a Geyser

212° F. Increasing the pressure causes water to boil at a temperature higher than 212° F. For example in Fig. 104, the boiling points of water are shown at the different depths, 250° and 275° F., and, where the pressure due to the weight of water is greatest, the boiling point is shown to be 300° F. The temperature actually found at a depth of 406 feet, in Old Faithful, was 338° F.

If the fissure connecting the source of hot water to the surface is large, the water will rise by convection as it gets hot, and we have a hot or boiling spring. But if this fissure is narrow, then we get the effect of a coffee percolator. Convection is prevented in a narrow tube because the overheated water down below cannot rise and mix with the cooler water above; it gets hotter and hotter until it reaches the boiling point (300° F. in Fig. 104). At that temperature it changes to steam which pushes some of the water out of the tube. That reduces the pressure and hence decreases the boiling point to less than 300° F., let us say 250° F. Therefore the entire mass of water which is at or near 300° F. boils instantaneously, changing to steam; that is to say, it explodes, expelling the water above it with violence. The explosion lets the pent-up steam escape, and hence the water settles back into the fissure to be heated over again.

**127. Destructive work of ground water.** Where the underground water is in motion, we get the same results as in stream erosion; but that is rare. The chief processes by which subsurface water acts are oxidation and solution.

Pure water alone has little effect on rocks — the only two which are soluble being rock salt and gypsum. But water containing dissolved oxygen and carbon dioxide readily attacks rocks containing particularly the elements calcium, magnesium, and iron. Water containing dissolved iron wets the soil and the bedrock, and, by oxidation, it is often changed to rust. This accounts for the rusty color



N. H. Darton, U.S.G.S.

FIG. 105. A Large Sink Hole

of most soils and rocks. Water containing dissolved calcium or magnesium salts is called *hard water*. It forms insoluble precipitates with soap and, when used in boilers, it deposits boiler scale. Such water may be softened by boiling or by adding washing soda.

The principal rocks affected by the solvent action of the ground water are limestone and marble, both of which are calcium carbonate. There are few regions on the earth which do not contain some limestone beds either on the surface or along the underlying rock formations.

If the limestone is on the surface, the water charged with carbon dioxide from decaying vegetation slowly dissolves it, aided often by fissures in the rock. These cracks are enlarged until great holes are formed, called *sinks* (Fig. 105). If these sink holes are very numerous, the drainage of the entire region may be underground, and there are no surface streams. This is true in the Karst region, east of the Adriatic Sea, and the term *karst topography* refers to that kind of region.

Many of these sinks are above the water table; hence they are dry. But there are others, like the small lakes of

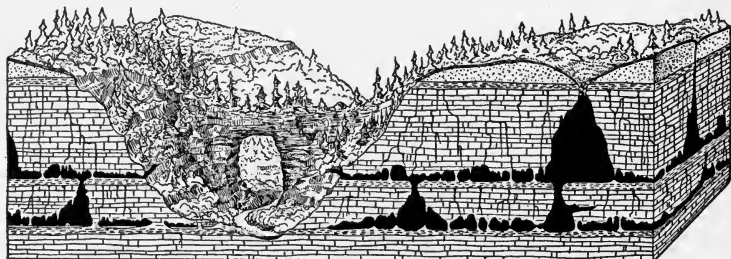

FIG. 106. Sink Hole, Caverns, and Natural Bridge in Limestone

Can you find each of these features in the figure?

northern Florida, which are below the water table and hence filled with water.

**128. Caverns.** When the hole dissolved out by the water and carbon dioxide is entirely below the surface, a *cavern* is the result. This will be permanent if the roof is an insoluble layer of rock, like shale (Fig. 106). If it is all limestone, the roof ultimately falls in and we have a sink. But sometimes part of the roof is left as a *natural bridge* (Fig. 106). Caverns are found in all parts of the world. Examples are: the Mammoth Caves of Kentucky, the Luray Caverns of Virginia, Howe Caverns in New York, Carlsbad Caverns in New Mexico, and others in Florida, Cuba, the Philippines, Indo-China, and Switzerland. The Mammoth Cave has a network of galleries and passages which cross and recross

one another, with a total length of over two hundred miles. It has rivers and lakes. The Carlsbad Cavern is about 1,000 feet deep. One of its rooms is 200 feet wide by a half mile long.

Caverns often contain fossils of animals and men. The best-preserved skeletons of prehistoric man, as well as samples of his handiwork, are found in caverns in France, Belgium, and Spain.

★129. **Calcareous deposits from ground water.** When water containing calcium bicarbonate (formed by the solution of limestone in water and carbon dioxide) finds its way through a fissure to the roof of a cavern, it often hangs there in drops. If the pressure decreases slightly or the temperature rises, the calcium bicarbonate decomposes into its original components: calcium carbonate (limestone), carbon dioxide, and water. This is shown in the following equation:

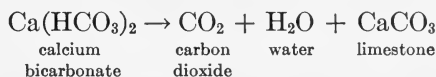

The calcium carbonate collects on the ceiling of the cavern and increases in size, as drop after drop of the liquid undergoes the change. The form of the deposit is like icicles hanging from the roof. They are called *stalactites*.

Some of the drops fall to the floor of the cavern and there build up a deposit of calcium carbonate, called *stalagmites* (Fig. 107).

★*Travertine* is the term applied to limestone deposited from waters, so that stalactites and stalagmites are forms of travertine.

When travertine is deposited rapidly on plants growing near springs, it forms a soft porous mass with holes in it, through which grasses grow; and often it has impressions of leaves and twigs in it. This is called *calcareous tufa* or *petrified moss*.

Several dense varieties of travertine are formed by slow evaporation of hard water (calcium bicarbonate), and show bands of different colors, due to impurities. The so-called Mexican onyx is the most attractive form of banded travertine, and it is much used for ornamental stone work.



*Photo by Russell, U.S.G.S.*

FIG. 107. Stalactites and Stalagmites, Carlsbad Cave, New Mexico

**130. Other deposits from ground water.** Alkali is formed in arid regions by the evaporation of ground water. This material has been dissolved out of the rocks, but since there are no permanent streams, it is not carried into the ocean, as it is in humid regions. Hence it collects in the soil and as the ground water moves to the surface and evaporates, it leaves an incrustation of *alkali*. The chief constituents are sodium chloride, sodium sulphate, and sodium carbonate, the latter having alkaline properties.

If there is not too much of it, the alkali may be removed by flooding the ground; but often this remedy makes the ground worse, by bringing so much alkali to the surface that the land is ruined.

Ground water containing dissolved mineral matter often deposits material in the pores or cracks of rocks. It is in



this way that loose mantle, like sand or gravel, is often consolidated into compact rock like sandstone or conglomerate. The cement is most commonly calcium carbonate; but often it is iron carbonate, and sometimes it is silica.

★Material deposited in a fissure, from solution, is called a vein, and most often veins are made of calcite or quartz (silica); but sometimes gold, silver, copper, and other metallic compounds are deposited in veins, and many of these deposits are worked as valuable ores. It is believed that most sulphide ores owe their concentration to a process called secondary enrichment. The primary ore deposit is often not workable, but as the ground waters take the oxidized surface ores into solution they often precipitate them out in some deeper zone in more concentrated form, making it worth while to extract them.

Silica deposited from solution in rhythmic layers forms agate, in which the colors are due to impurities.

Opal is a kind of silica formed in this way. In some cases, trees have been changed to *petrified wood* by a deposit of silica which has replaced the woody material, as fast as it was removed, cell by cell.

*Geyserite* is another form of silica deposited in and about the crater of a geyser.

Material in solution — silica, calcium carbonate, etc. — sometimes precipitates around a solid like a piece of bone or stone to form a *concretion*. When these are broken open, we may find fossil insects, fern leaves, or the shells of marine animals.

Sometimes quartz, calcite, or other minerals are found in a fissure or cavity with their crystals growing out from the walls. If a cavity is only partially filled by such crystals, we may get a *geode*. These often look like rounded stones which are found to be hollow and lined with crystals.

**131. Summary.** Solution and deposition by ground water tends to

1. Collect metallic minerals that were widely scattered, to form valuable veins of ore.
2. Repair breaks and fill cavities in bedrock.
3. Cement mantle into compact rock.
4. Form sinks and caverns.

## 132. Deposits formed by ground water.

CAUSES	LOCATION	MATERIAL	FORM
Evaporation	a. Surface of soil b. Bottom of lake	Alkali Gypsum, salt, etc.	Incrustation Stratified
Changes in temperature and pressure	a. Cavities and fissures	Ores, silica, calcite, etc.	Veins
	b. Porous rock	Silica, calcite	Cement
	c. Geysers	Geyserite	Craters and cones
Loss of carbon dioxide	a. Ceiling of cavern b. Floor of cavern c. Near springs	Travertine Travertine Calcareous tufa	Stalactite Stalagmite Stratified
Chemical action, precipitation	a. Fissures b. Porous rocks	Sulphide ores Calcite, silica, iron oxide, etc.	Veins Cement

*Completion Summary*

Ground water ——— water table.

A body of water, like a river or lake, is formed wherever the ——— surface.

In humid regions, the water table ———, whereas in arid regions ———.

A well ——— water table. Wells should be located ———.

An artesian well ——— aquifer as well as ——— impervious ———.

If the intersection of the water table with the surface causes a small stream of water ——— spring.

★A geyser owes its intermittent action to water being heated ——— boiling point in tubelike ———. The action resembles that of ———.

Subsurface water containing dissolved ——— limestone. If the limestone ———, sinks are formed. If the limestone is capped by a layer of ———, a cavern ———.

If the water containing dissolved limestone is warmed, the limestone will be redeposited.

The deposits hanging from the roof ——; those growing up from the floor ——.

—— in arid regions, by evaporation of ground water.

### *Exercises*

1. What factors control the amount of rainfall that supplies the ground water?
2. How does vadose water differ from ground water?
3. State the approximate per cent of water contained in different kinds of rock.
4. Draw a diagram, different from the one in the text, to show the water table.
5. Why is the water table not permanent?
6. What is the maximum depth to which ground water can percolate?
7. What effect has the water table on agriculture?
8. How does the water table in a humid region differ from that in a dry region?
9. What is a well? Explain with diagram.
10. Explain how wells become contaminated.
11. Where should a well be located?
12. Show by diagram, different from the text, that a well may not be safe although it is above the source of contamination.
13. State the laws of sanitation for wells.
14. What is an artesian well? Show by diagram.
15. Define aquifer. What kind of rock does it usually consist of?
16. Why is artesian water superior in quality to ordinary well water?
17. What is a spring? Show by diagram.
18. What are mineral springs?
19. What evidence is there that hot springs have some connection with volcanic activity?
20. What elements are dissolved out of rocks by water containing carbon dioxide?
21. Why are most soils brown?
22. What are sink holes? How are they formed?
23. What is karst topography?

24. A great number of small lakes in a limestone region indicates what origin for the lakes?
25. What conditions are necessary for the formation of a cavern?
26. What conditions are necessary for the formation of a natural bridge?
27. How are stalactites formed? stalagmites?
28. What is *alkali*?
29. How is sandstone formed from loose sand?

**★Optional Exercises**

30. Show how each of several conditions determines the amount of ground water.
31. Explain with diagram why the intersection of the water table with the surface produces a swamp, in one case, and a lake in another.
32. What is a perched water table?
33. Show with diagram how a gully can ruin a piece of ground for farming.
34. Discuss irrigation, its relation to the water table and to productivity.
35. What is dry farming? What effect has it had on the land?
36. Explain the impossibility of locating an artesian well in igneous or metamorphic rock.
37. Explain the resemblance between an artesian well and a fissure spring.
38. Explain the action of a geyser.
39. Explain the chemistry of the formation of hard water and its relation to limestone caverns and stalactites.
40. If a topographic map showed no streams in a humid region, what kind of rock would that indicate for the surface?
41. Why is it reasonable to expect to find fossils of men and animals in cavern deposits?
42. What is travertine?
43. How are agate, opal, and petrified wood formed?
44. What relation, if any, exists between the water table and an artesian well?
45. What reasons are there for believing that the water supply of your town is not contaminated?

## CHAPTER XI

### LAKES AND SWAMPS

**133. Origin of lakes.** Lakes are relatively large bodies of water, filling basins or depressions in the land. We have already studied the origin of glacial lakes, sink holes in limestone, and oxbow lakes. Most lakes are above sea level, but some are at sea level — coastal lagoons. The great majority of lakes are a result of glaciation and therefore we find them very numerous in regions that have been glaciated, and these regions are found in high latitudes and altitudes. That being so, if drainage is good, the lake is bound to disappear, and it is only in humid regions, *where drainage has been interfered with*, that a lake is developed.

Lake basins have the following origins:

- |                                   |                                       |
|-----------------------------------|---------------------------------------|
| 1. Movements of the earth's crust | 4. Rivers                             |
| 2. Volcanoes                      | 5. Marine erosion                     |
| 3. Glaciers                       | 6. Sink holes (solution of limestone) |
| 7. Artificial                     |                                       |

**134. Lake basins formed by movements of the earth's crust.** Lakes may be formed by uplift of the land so as to trap an arm of the sea, enclosing it on all sides. This is believed to be the origin of the Caspian Sea, which is salty. Depression of the land surface is an occasional cause of a lake basin. In 1811, a large but shallow basin of this type, known as Reelfoot Lake, was formed in the Mississippi Valley after an earthquake.

Other examples of this type of lake basin are Lake Baikal in Siberia and the thirty or more lakes of the Great Rift Valley, extending 4,000 miles from the Dead Sea to the

African lakes, Tanganyika and Nyassa. Many of these lakes are almost a mile deep.

**135. Lake basins formed by volcanoes.** Lakes sometimes occupy the craters of extinct volcanoes. Crater Lake, Oregon (Fig. 108) and Lake Avernus, near Naples, Italy,



J. S. Diller, U.S.G.S.

FIG. 108. Crater Lake Showing Steep Sides

are fine examples. Such lakes have very steep sides and are often very deep. Crater Lake is 2,000 feet deep. Lava flows from volcanoes sometimes dam up a river and form a lake

in that way. Lake Tahoe in California and several lakes around Mt. Hood and other former volcanoes have this origin. They are called *coulee* lakes.



FIG. 109. A Cirque Lake

**136. Glacial lake basins.** Glaciers quarry out large basins at their source, called *cirques*, and these are some-

times filled with water. They are often called mountain lakes or *tarns*. Iceberg Lake in Glacier National Park has walls almost 3,000 feet high. It is a cirque lake (Fig. 109).

Most glacial lakes are the result of deposits. Ninety per cent of all known lakes are of this type — formed by ob-

struction of drainage by glacial till. Many small glacial lakes are formed in kettle holes by the melting ice (Fig. 110). Such lakes always occur in groups. When a glacier blocks the natural drainage of a region, the water accumulates in the basin, one side of which is the glacier. Such lakes are found only near the polar region; but during the Glacial Period they were large and numerous in the temperate



FIG. 110. How Kettle Lakes Are Formed

The glacier on the right once covered the entire land. As it receded, it left blocks of ice in holes. One of these, on the extreme left, has formed a kettle lake. zone. Glacial Lake Agassiz, one of this kind, was the largest lake that ever existed (Fig. 89).

The Great Lakes, the Finger Lakes of New York, and thousands of lakes in Minnesota and other northern states and in Canada are of glacial origin.

### 137. Lake basins formed by rivers.

*Oxbow lakes.* Figure 59 is a map of the flood plain of the Mississippi River near the mouth of the Big Black River. It shows five oxbow lakes. Lake *A* shows an early stage in the formation of an oxbow basin. A cutoff has been formed recently, but the lake is still connected with the cutoff at both ends. Lakes *C* and *D* have been separated from the river at one end by a deposit of sand. At the other end, water connection with the river is still possible. Lakes *B* and *E* are entirely disconnected from the river by sand deposited in the ends of the former meander.

The three stages in the formation of an oxbow lake basin are:

1. Formation of a meander
2. Formation of a cutoff (*A*)
3. Separation of cutoff from river (*B* and *E*)

*Basins at the mouths of tributaries.* We have seen that the banks of an old meandering river are higher than its flood plain. When the river is in flood, it occupies the depressions on the flood plain, between the natural levees and the valley walls, and forms lakes. As the flood recedes, much of this water will find its way back into the river; but when a tributary enters the main channel it may furnish sufficient water to form a permanent lake, which may collect until it flows over the top of the levee. Lake Maurepas near New Orleans is of this type.

*Delta lakes.* Since tributaries are younger than the parent stream, their gradient is steeper. When, therefore, they join the main stream, their velocity is reduced and deposition takes place. If this change of velocity is sufficient, a delta will be formed, blocking the main channel and forming a lake. In this way the Chippewa River deposited more sediment in the Mississippi than it could carry away, and the delta thus formed dammed up the Mississippi, which expanded into Lake Pepin.

Lake Pontchartrain (Fig. 111) was formed when the delta of the Mississippi, by wave action and shore currents, was distributed so as to cut off an arm of the sea.

The Salton Sea in California is a former arm of the sea, cut off by the delta of the Colorado River. In recent geological time, its basin has sunk so that it is now below sea level.

**138. Lakes formed by marine erosion.** Lake Pontchartrain, mentioned above, is an example of a lake formed by the action of waves and currents on delta deposits.

On irregular shores, marine erosion often traps a small part of the sea by building barriers. The tide usually maintains a connection through such barriers, but the water of the *lagoon*, as such a lake is called, is quiet (Fig. 112). On shore lines of emergence (see page 514), the regular coast soon becomes broken up by these lagoons, formed by wave action. There is a succession of them on the Atlantic Coast from New York to Florida.



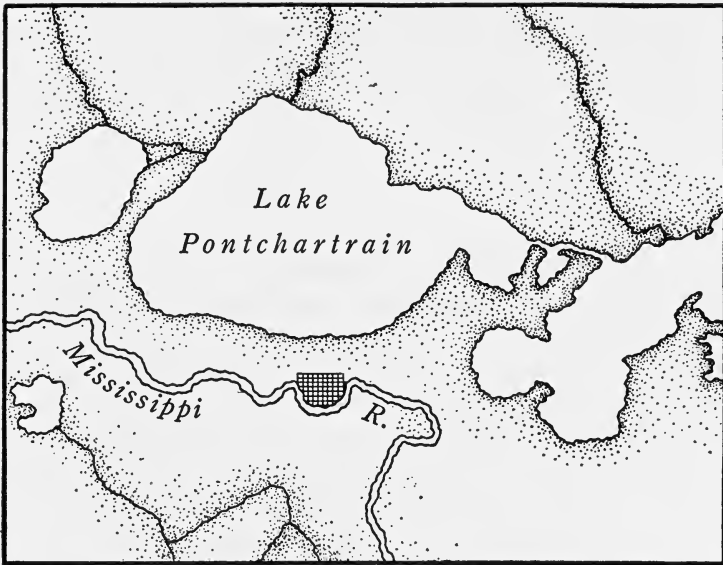

FIG. 111

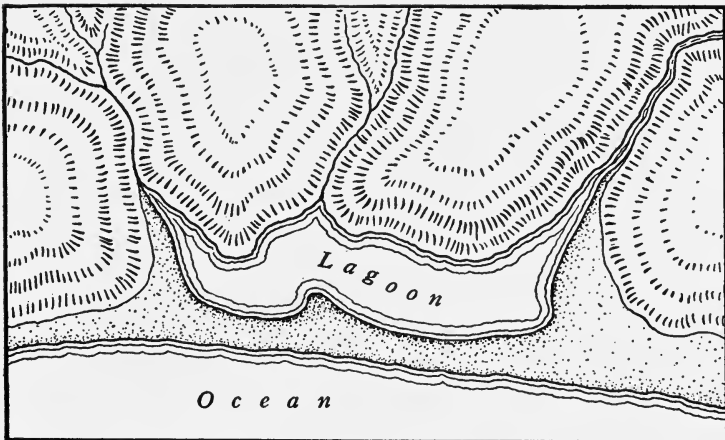

FIG. 112. This lagoon is entirely cut off from the ocean.

**139. Lake basins formed in limestone.** In the study of ground water we mentioned the formation of caverns and sinks in limestone regions. If the bottom of the sink is

below the water table, it will be filled with water; otherwise it will be dry unless the bottom is choked with impervious material. There are hundreds of these small lakes in Kentucky, Indiana, and Florida.

**140. Salt lakes.** Some of the salt lakes, like the Salton Sea, were at one time arms of the sea, but others started as fresh-water lakes. They are all situated in arid regions where evaporation exceeds inflow and there is no outlet to the sea. The volume of water diminishes and evaporation therefore slows down until an equilibrium is established. At this stage the loss by evaporation *equals* the inflow and the lake remains the same size. But since the inflowing waters contain dissolved salts, while the evaporated water is pure, the water of the lake increases in saltiness year by year. This is the history of the Salton Sea, the Dead Sea, the Great Salt Lake, and the Caspian Sea. Lake Champlain, on the other hand, started as a part of the sea, but since it had an outlet and was in a humid region, the salt was gradually washed out until today it is a fresh-water lake.

The Great Salt Lake contains about 20% salt, chiefly sodium chloride (common salt), sodium sulphate (Glauber's salt), and magnesium sulphate (Epsom salts).

Some lakes contain considerable Glauber's salt, soda, borax, or Chile saltpeter. These are called *alkaline lakes*. White deposits of some of these chemicals may be seen on the shores and upon all objects that project above the water of Soda Lake. Searle's Lake contains all of these chemicals, and a number of lakes in the Great Basin are important sources of one or more of them.

The Great Salt Lake is the shrunken remnant of Lake Bonneville, which was at one time as large as Lake Huron. The wave-cut terraces of the ancient lake, showing the different levels of the lake shore in times past, may be seen in Fig. 113.

**141. Playa lakes.** Where rainfall is slight, in arid and semiarid regions, lakes appear with every rain, only to dis-

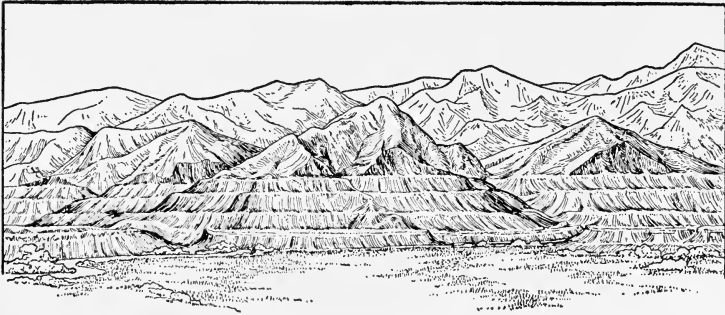

FIG. 113. Terraces of Ancient Lake Bonneville

appear before the next rain. Evaporation is rapid and the water table is so far down that most of the streams are not permanent. Such intermittent lakes are called *playas*. They are common in Nevada, Utah, and Arizona. The soils that make up the basins of playa lakes are usually alkaline.

**142. Destruction of lakes.** Some lakes, like *playas*, disappear by evaporation, but in a humid region the inflow will exceed the evaporation and hence the level of the lake will rise until it overflows its rim. That starts a river which begins erosion and, by this process, the rim of the lake is cut deeper and deeper until the lake is drained. *Rivers are the mortal enemies of lakes.*

At the same time the water entering the lake brings sediment (Fig. 114), which is deposited and helps to fill up the lake. As it becomes more and more shallow, plants begin to grow near the edges and help to fill it up until the lake is nothing but a swamp, and even this is ultimately filled with silt and converted into a plain.

Certain kinds of moss and some other plants sometimes grow on the surface and hold wind-blown sand and dust which gradually spread over the lake, forming a floating bog. A railroad line in Minnesota crossed such a bog. Cattle grazed upon it before the line was built; but the engineers discovered that the floating bog was a mass of vegetable matter and dust, four feet thick, and that beneath it was



*W. H. Jackson, U.S.G.S.*

FIG. 114. Delta Deposits in a Lake



*Acme*

FIG. 115. A Lake Being Destroyed by Vegetation

twenty feet of water. Prairie Tremblant, Louisiana, is a floating bog through holes in which fish may be caught.

Eel grass and wild rice also assist in filling in lakes.

These methods of filling gradually convert a lake into a swamp or marsh, and many of our fresh-water marshes are former lakes which have been destroyed in this way.

**143. Importance of lakes.** Lakes regulate the flow of rivers and so prevent floods. If the Mississippi and its branches had their sources in large lakes, there would be no great floods in the Mississippi Valley, just as there are none in the St. Lawrence Valley. The building of such reservoirs, artificially, has been recommended as one means of preventing the disastrous floods which occur in the Mississippi Valley.

Lakes moderate the climate of the neighboring lands because the water warms up more slowly than the earth and cools the land in summer, while it does not cool out rapidly in winter and therefore warms the land.

Lakes that are high enough furnish water power, while others are used as sources of drinking water for cities and for irrigation in dry regions. New York City has provided an available storage capacity of 150 billion gallons in the Ashokan and Schoharie reservoirs in the Catskill Mountains. These are in addition to the reservoirs at Kensico, Hill View, and Silver Lake.

The Roosevelt Dam forms a lake of more than 16,000 acres, 250 feet deep, and supplies water for irrigation to the inhabitants of that section of Arizona. Boulder Dam will impound the waters of the Colorado, making a large artificial lake of 230 square miles (Fig. 116). It will furnish water for irrigation to the inhabitants of several of our southwestern states and Mexico, and drinking water for the city of Los Angeles.

The Great Lakes are important arteries of commerce over which the products of the middle west—for example iron ore and wheat—find their way to the great commercial centers of the east, New York, Buffalo, Cleveland, and Pittsburgh.

Lakes also have great value as pleasure and health resorts.

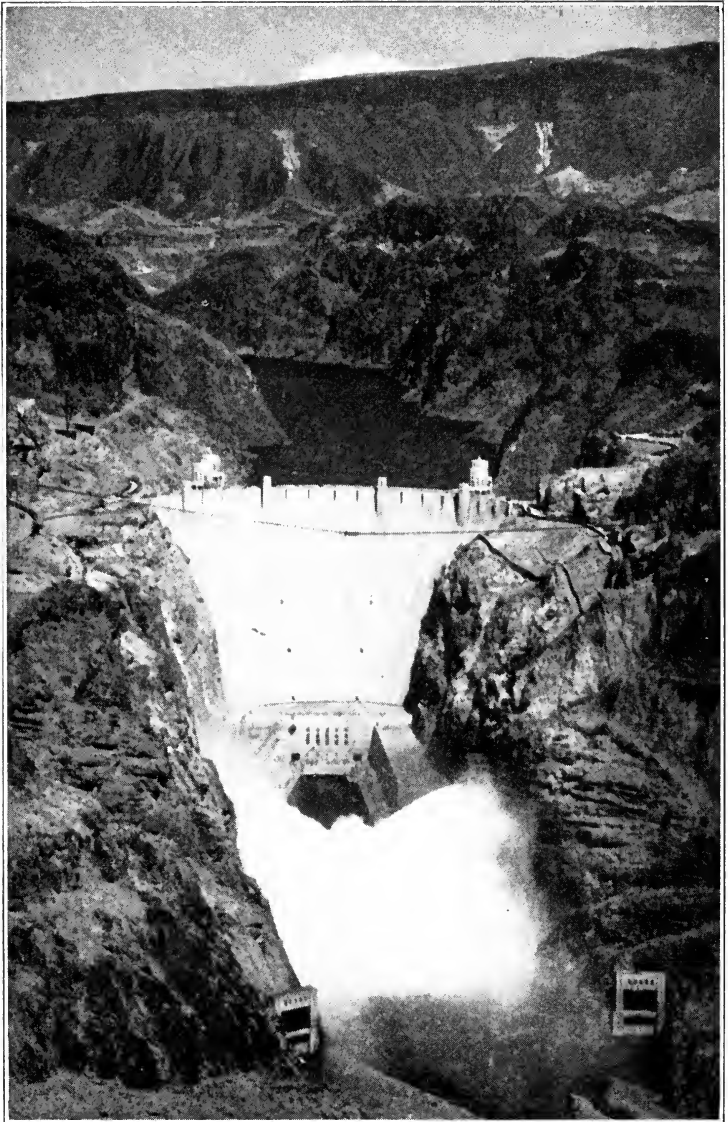

*U. S. Bureau of Reclamation*

FIG. 116. Boulder Dam

★144. **Swamps.** In paragraph 142, it was shown that a lake is destroyed by filling and draining and that near the end of its existence it becomes a swamp. Most swamps are of this origin.

Swampland is saturated with water — that is, the water table intersects the surface — but it is not *covered* with water. If the surface is covered with water, it is either a pond or a lake.

The flood plain of an old river is usually swampy because the rainfall is trapped between the natural levees and the valley wall

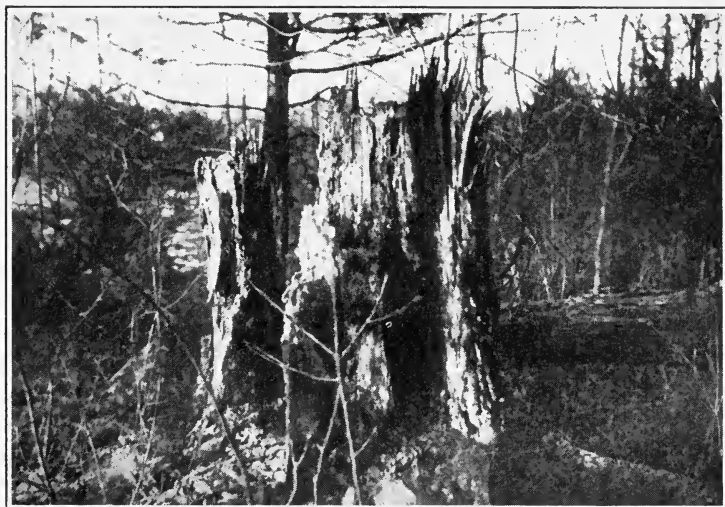

FIG. 117. A Scene in the Dismal Swamp of Virginia

*Acme*

and the land is very flat. There is much swampy ground along the lower reaches of the Mississippi. Glaciated regions are full of lakes and swamps, because of interference by the glacial drift with natural drainage.

Coastal plains, which are very flat, often are swampy. Such is the origin of the Dismal Swamp in Virginia and the Everglades in Florida.

Swamps have a great deal of vegetation, particularly of certain kinds which like saturated soil. In the cooler climates, sphagnum moss is a common swamp growth. It grows out from the sides of a pond along the surface. At the same time, decaying plant material helps fill in the water under the sphagnum, until in time the entire

surface may be covered with a thick mat under which there is a mass of decaying vegetation mixed with water. This is a *quaking bog*. As an animal walks on it the floating mass moves and sometimes breaks through, so that we find fossils in these bogs.

★145. **Formation of peat.** When a lake is destroyed by the encroachment of plants from the shore, the dead plants decay through the activity of microbes, but this very process produces some compounds which are antiseptic and ultimately kill the bacteria. From then on, the partially decayed plant material will be preserved. This is *peat*. It is dark brown in color, and roots and other parts of plants may often be recognized in it. Other plants grow on top of the peat and push it down by their weight, and in time the entire lake becomes a peat bog with the lower layers of peat more and more consolidated. Peat is the first stage in the formation of coal.

In some of the past ages of the earth's history, particularly the Pennsylvanian, large areas of the land were low and swampy and the climate was warm. Conditions were ideal for peat making and as a result most of our coal was laid down during that time. The trees, however, were quite unlike those we know today: no oak, beech, or maple; but gigantic ferns and scale trees. (See page 276 for description of a Pennsylvanian forest.)

Where coal is not found, as in Ireland, the inhabitants often use peat as fuel; and no doubt, when our extensive coal deposits are depleted, we also shall use the enormous amount of peat in our swamps.

★146. **Economic aspects of swamps.** Certain diseases, like malaria and yellow fever, are prevalent in swampy regions and are carried by mosquitoes which breed in swamps. This is particularly true of tropical regions.

Few plants will grow in saturated soil; but when swamps are drained the soil is very fertile. There are 64 million acres of swamp-land east of the Appalachian Mountains that can be reclaimed. This is being done on a small scale in this country, where land is plentiful; but in the Netherlands such reclamation of land has been going on for centuries. About half of the present agricultural lands of the Netherlands (the word means *lowlands*) has been reclaimed from the sea by building dikes and pumping out the water, and pumps are constantly in operation in order to keep these lands drained.



*Completion Summary*

A lake is formed wherever ——— drainage. Most lakes are of ——— origin.

——— lakes are formed on old river basins.

Lagoons are lakes formed by ———, which cuts off ———.

Sink holes in ——— regions become lakes, if their bottoms ——— water table or if ——— choked.

Salt lakes develop in ——— when evaporation ———.

Intermittent lakes, called ———, exist in ——— regions.

Rivers are the mortal enemies of lakes. They ——— sediment, and by cutting down the lip of the lake basin ———.

Lakes ——— floods, are useful as ——— drinking water, ——— irrigation, and some ——— water power. Some lakes ——— navigation.

★Where the water table is just at the ——— swamp. Swamps are therefore common ——— and on the flood plains of ———.

Peat is formed in swamps because decay brought about by microbes produces ——— and preserves ———. Peat is the ——— in the formation of coal.

When swamps ———, ——— very fertile agricultural lands.

*Exercises*

1. Explain why we find lakes only in humid regions, where drainage has been interfered with.

2. Make a table showing the origins of lakes and, for each one, state briefly how drainage was interfered with, to produce the lake.

3. Name a lake which is believed to have been formed by crustal movement.

4. Name a lake of volcanic origin.

5. What is a coulee lake?

6. State three ways in which a glacier may form a lake.

7. Name lakes of glacial origin.

8. How and where is an oxbow lake formed?

9. Show how lakes may be formed where tributaries enter an old parent stream.

10. How is a delta lake formed?

11. What is a lagoon?
12. Under what conditions do sinks become lakes?
13. Explain how a salt lake is formed.
14. What is an alkaline lake?
15. What is a playa lake?
16. In what two ways do rivers destroy lakes?
17. Mention an artificial lake.
18. State several functions performed by lakes.

**★Optional Exercises**

19. Distinguish between a lake and a swamp.
20. Where are swamps very common? Why?
21. What is a quaking bog?
22. How is peat formed?
23. What dangers lurk in swampy regions?
24. Why are reclaimed swamplands fertile?
25. Explain how glaciers form lakes.
26. Name lakes of glacial origin, not mentioned in the text.
27. Trace the life history of an oxbow lake.
28. What is the origin of Lake Pontchartrain?
29. Explain the formation of lagoons on emerging shores.
30. Trace the life history of a lake.

## CHAPTER XII

### PLAINS

**147. What are plains?** The surface of the earth is, in most regions, rather uneven; but here and there we find it relatively flat with few inequalities. Such a region is called a *plain*.

Plains are usually lowlands, some of them as smooth as a table, relatively, while others are slightly rolling. The smooth surface of a plain is due to deposition of sediments

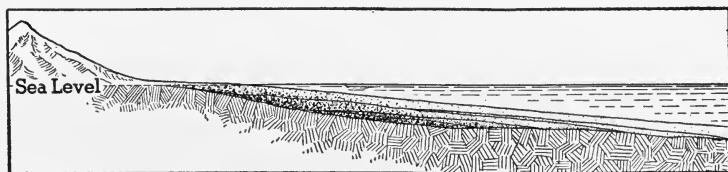

FIG. 118. The layers of sediment deposited in the ocean have a smooth surface.

in water (Fig. 118). In a lake or in the ocean the sediments brought down by rivers are spread out on the bottom, in layers which are practically horizontal. When these underwater layers emerge, by either the drainage of the lake or the uplift of the ocean floor by earth movements, we have a plain, unless, in the uplift, the layers are sharply tilted or folded.

Plains are also formed by erosion. This process gradually wears down the higher places and carries away the material formed, until there remain only a few places higher than the general level. Such a plain is never quite smooth and is therefore called a *penplain*, which means "almost a plain."

**148. Peneplains.** The peneplain is the final stage of the cycle of erosion. In the beginning, erosion increases the re-

lief or unevenness of the land because weaker rocks are worn down faster. Streams soon carve their courses in these weaker rocks and carry away the products of weathering. But as soon as the erosion of the weak rock has reached *base level* it can no longer continue, because *at base level water does not flow*.

While the weaker rocks have been wearing down rapidly, the harder ones have also been weathering, but more slowly; and, in fact, wherever they stand higher than the weaker ones, they will wear rapidly. Both hard and soft rocks will wear down, then, the harder ones always remaining as outstanding features of the land, like ridges.

When the region has reached old age, the rivers have broad flood plains, with here and there an isolated hill, usually composed of very resistant rock. These remains of the former highland are called *monadnocks*, after Mt. Monadnock in New Hampshire (Fig. 119).

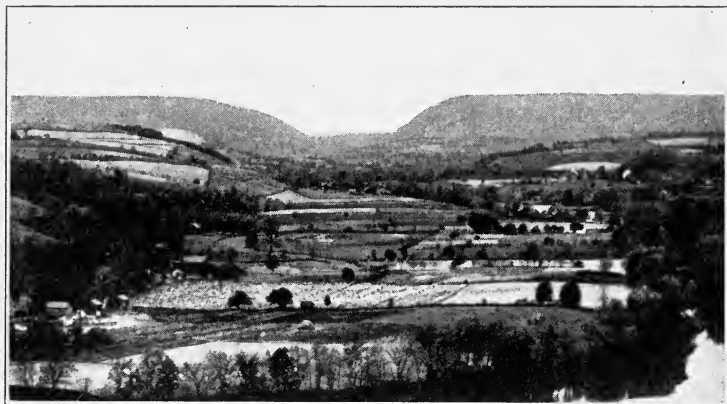

FIG. 119. Mount Monadnock stands out from an otherwise level sky line.

★In sufficient time, monadnocks would also be worn down to base level; but as the region gets closer and closer to base level, the rate of erosion becomes slower and slower and rejuvenation of the region always interrupts the last stage in the erosion of the monadnocks. When a peneplain is uplifted it presents a very even sky line (Fig. 120). Soon the work of erosion begins again to cut up the surface and make it uneven, but there usually remain enough evidences to enable one to detect the former peneplain. The Appalachian Mountains were once peneplaned but they have since been uplifted again and, although deeply dissected, *the highest points are at the same general level*.

The rock mantle of a peneplain may consist of sediments deposited in former lakes and rivers or of drift deposited by a con-

tinental glacier; but these local deposits do not indicate the true history of the region. It is the erosion of the bedrock, rather than the differences in the thickness of the mantle, which gives the region its plainlike character.



*G. W. Stose, U.S.G.S.*

FIG. 120. An Uplifted Peneplain

The sky line is straight, except where a river has cut its valley.

**149. Plains formed by deposition.** Many plains owe their smooth, flat upper surface to deposits of rock mantle.

Most of the agents that transport and deposit rock mantle form flat-topped deposits. The characteristics of these deposits will depend upon (1) the agent transporting the material and (2) the conditions under which it is deposited.

There are four classes of plains of deposition.

1. Marine or coastal plains, formed by uplift of the sea bottom
2. Alluvial plains (formed by rivers)
  - a. Flood plains along the river course
  - b. Deltas at the mouth of the river
  - c. Piedmont alluvial plains
3. Lake plains, left after a lake has been destroyed
4. Glacial plains

**150. Coastal plains.** Coastal plains are composed of rock waste cut from sea cliffs by wave action or carried to the ocean by rivers. The movements of the water spread the loose material out into smooth, gently sloping deposits such as we see on all beaches; but the beach is only the part of the deposit that is above the water, while the rest sometimes extends a hundred miles from shore.

The smooth, gently sloping deposit is called the *continental shelf* and when it is uplifted, it is called a *coastal plain*.

★The surface material of a newly uplifted coastal plain is assorted and stratified into nearly horizontal layers, unless, in the uplift, the strata have been tilted or folded.

Coarser layers of gravel will usually be found underneath, with sand on top of gravel and silt and clay on top of all. This is in perfect agreement with the cycle of erosion, since, when the land near by was high, the streams were capable of carrying gravel, while later, after erosion had reduced the elevation, the streams could carry only fine material.

Frequently the rock mantle is quite loose and unconsolidated. Coastal plains are therefore very porous and permit ground water to flow through them readily. But a layer of clay, which often tops the others, makes an impervious covering and hence the conditions for artesian wells are often found on coastal plains.

When a coastal plain is young, the surface is smooth, drainage is simple, and the shore line is regular. The greatest coastal plain in the world forms the northern and western part of Siberia. It has a maximum width of more than one thousand miles. On the shores of the Bay of Bengal is a narrow coastal plain not more than fifty miles wide. On the western coast of the United States, coastal plains are unimportant, although there are some narrow plains, like that at Los Angeles.

★151. **The Atlantic Coastal Plain.** This interesting plain lies along the Atlantic coast from New York to Florida. An extension

of the Atlantic Coastal Plain called the Gulf Coastal Plain extends from Florida around the Gulf of Mexico. Its width varies from half a mile to five hundred miles.

The rock waste forming this vast deposit, which in places is several hundred feet thick, came mostly from the eastern slope of the folded Appalachian Mountains. During the period of deposition, the region which is now the coastal plain was of course submerged, the ancient shore line being near the present "fall line" (Fig. 121).

As soon as it was uplifted, the streams flowing into the Atlantic cut deep valleys in the soft deposits of the new coastal plain.

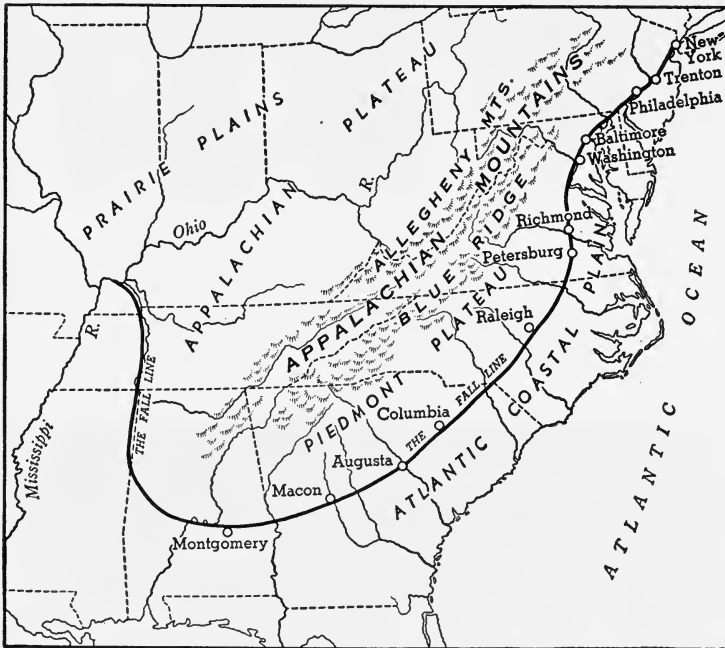

FIG. 121. The Atlantic Coastal Plain, Showing the Fall Line

This period of erosion ended, for the eastern half of the coastal plain, when *it was again submerged*; this moved the shore line to about its present position, drowned the valleys that had been eroded, and gave us New York, Delaware, and Chesapeake bays, as well as the bays and sounds south of them, and many smaller

bays like those of the Navesink, Toms River, and Great Egg River of New Jersey.

The old river valleys, which extended farther east than they do now, can still be traced by soundings. It is said that the old mouth of the Hudson River is more than a hundred miles out to sea.

The shore of the coastal plain is low and marshy, but the land rises gently to the fall line. The strata beneath the soil are similar to those of the continental shelf and contain many marine fossils that prove the former submergence of the region.



*L. W. Stephenson, U.S.G.S.*

FIG. 122. Much of the Atlantic Coastal Plain is sandy.

In the Carolinas, rice is raised in the marshes. Between the marshes are wide areas of sand, of little value for agriculture, which are chiefly occupied by pine forests. Farther inland, the soil is fertile and much cotton is raised, while in some localities gardeners maintain successful truck farms.

At the western border of the Atlantic Coastal Plain, the land rises somewhat abruptly to the Piedmont Plateau. The rivers of this region usually have falls or rapids where they descend from the plateau to the plain. These falls furnish water power.

**152. Ancient coastal plains.** Geikie well says, "Only where the sediment is strewn over the sea floor beyond the limit



of breaker action, is it permitted to accumulate undisturbed. In these quiet depths are now growing the shales, sandstones, and limestones which, by future terrestrial revolution, will be raised into land, as those of the past have been."

The continent of North America has grown to its present size through the emergence of successive continental shelves, each one of which was for a time a coastal plain. Much of the present continent is therefore underlaid by sedimentary rocks.

Some of these former coastal plains still retain enough of their original characteristics to enable us to recognize them as "ancient coastal plains."

Other portions of them are now great mountain ranges, and still others have been great mountain ranges but are now so worn down that we call them plains.

**153. Plains formed by rivers.** Old streams have wide *flood plains*. During floods, when the river overflows its banks, it deposits alluvium on the flood plain. Most of this sediment is deposited near the river, because it is there that the water loses most of its velocity as it leaves its channel. This results in a smooth, nearly level surface that slopes away from the river, and ends in marshy "back swamps" at the outer edge of the flood plain.

★The materials forming flood plains are not arranged in continuous horizontal strata, but are exceedingly irregular, owing to the meandering of the river. As the flood subsides, the depressions, caused by new channels eroded by the river in flood, are filled with sediments which often differ from the others in fineness.

The flood plain of the Mississippi is about 80 miles wide at Greenville, Mississippi; it gradually decreases toward the north until at Helena, Arkansas, it is but 20 miles wide. The total area of the Mississippi flood plain is about 30,000 square miles.

★**154. Delta plains.** At the mouth of a stream, or wherever its velocity drops, an alluvial deposit will be formed, and it will usually have a flat surface. Alluvial deposits therefore form plains. The great delta plains are those of the Mississippi, the Po, the Rhine, the Ganges, and the Hwang Ho.

Delta plains have a fine mud surface, especially near the sea where they are often flooded. No part of the delta is much above sea level; the maximum, at the natural levees, is no more than 50 feet. For this reason, houses, towns, and roads are built on the natural levees.

Delta soils are often very fertile and easily tilled. With the increasing need for farm land, it is not surprising to find many deltas occupied by dense populations.



*U. S. Department of Agriculture*

FIG. 123. Farming on the Delta Plain of the Mississippi

The Dutch have not only taken possession of the deltas of the Rhine, the Meuse, and the Scheldt rivers, but they have built extensive systems of dikes and have pumped out the sea water in order to reclaim wide areas of the delta plains, some of which lie as much as 15 feet below sea level.

**155. Piedmont alluvial plains.** Where tributary streams with steep slopes come out of the mountains to join the main stream, their velocity is suddenly arrested and they drop most of their load, forming alluvial fans (Fig. 124).

In semiarid regions, we find alluvial fans particularly well developed, because the main streams have no water except when it rains. When it does rain, the tributaries, rushing

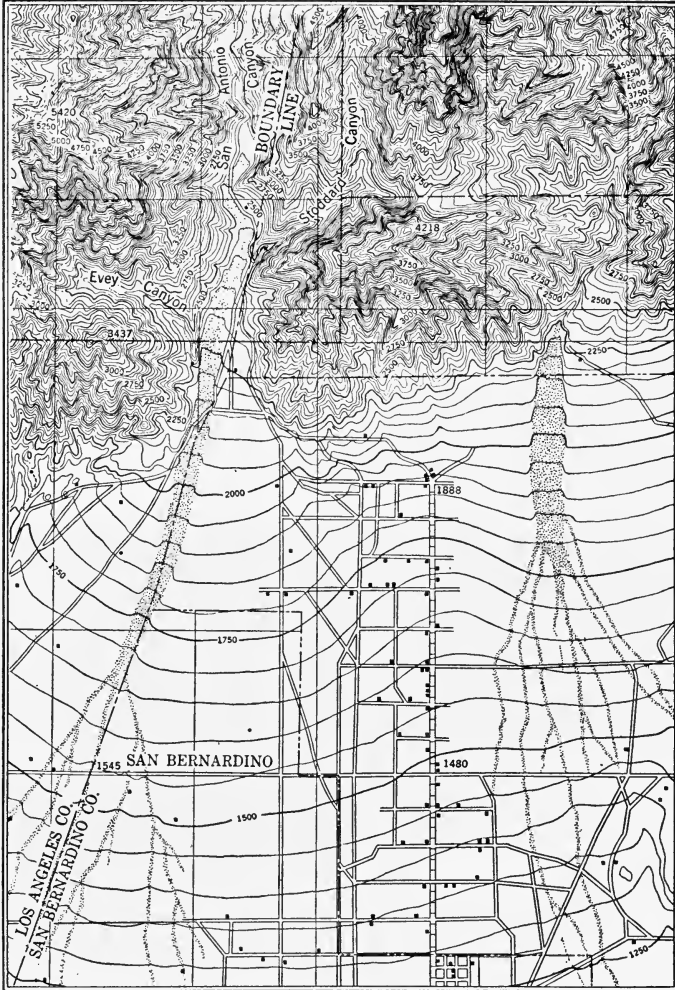

Part of the Cucamonga Sheet, U.S.G.S.

FIG. 124. The lower half shows a piedmont alluvial plain.

down the mountain sides and carrying a heavy load, come out on the main valley floor, where they spread out and drop their entire load. In time, neighboring fans coalesce and form one continuous *piedmont plain*. The name is derived

from a region in northern Italy, called Piedmont (foot of the mountains), where the tributaries of the river Po have formed an alluvial plain of this type. Such plains are usually several hundred miles long and very narrow. Our own San Joaquin and Sacramento rivers in California have formed piedmont plains.

Figure 124 shows the piedmont plain formed by the intermittent streams of the San Bernardino Mountains, in California. Note the fanshape of the contour lines curving outward from the point where each stream comes out of the mountains, and note how neighboring fans have coalesced.

★In arid regions, such plains are usually the sites of villages, because water can be obtained from the mountain streams or from wells. Most of the settlements in Utah are situated on piedmont plains west of the Wasatch Mountains, a range about 200 miles long that borders the Great Basin on the east.

On piedmont plains, there is little slope on a line *parallel* to the mountains, and roads and railroads usually follow such lines.

The surface of piedmont plains is often full of gravel and boulders near the mountains, but farther away it becomes fine and is good for farming wherever water is available. They furnish excellent sites for irrigation projects and some of them are famous for their agricultural produce. Such, for example, are the valleys of the San Joaquin and Sacramento rivers of California, where much of our fruit is grown.

**156. Glaciated plains.** Glaciers have produced plains of two types. In one, the rock surface has been rubbed flat by glacial erosion, while in the other, glacial deposits have filled in irregularities. The latter are known as *till plains* (Fig. 125).

Plains formed by glacial erosion are the Laurentian plain of Canada and those of Sweden and Finland. They are rolling plains, with many lakes, very little soil on the higher places, and swamps in the lower regions. Much of the land is covered by forest.

Glacial drift usually smooths the surface of the land and hence forms plains, especially in front of the glacier, where

streams work over the drift and assort it. These are *out-wash plains*. The plains of northern Ohio and of southern Long Island are good examples.



*Wisconsin Geological Survey*

FIG. 125. A Till Plain

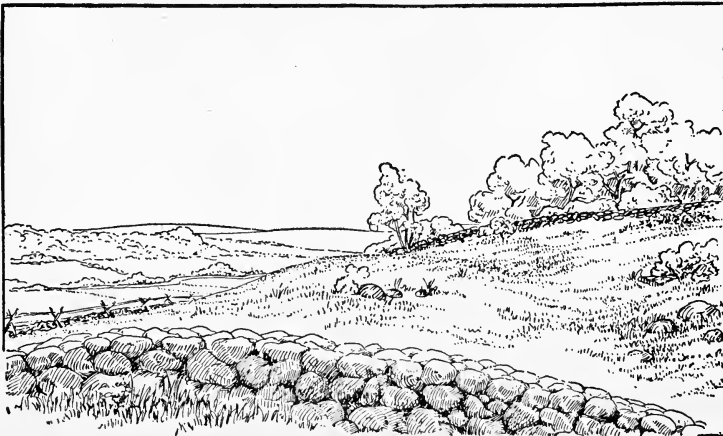

FIG. 126. Stone Wall Built of Glacial Drift

The soil of a glacial plain is composed of glacial till: large boulders mixed with small pebbles and sand. Much of this material is erratic, having been dragged from some distant

region by the glacier. These boulders are often so numerous as to interfere with the cultivation of the soil. In New England, where this condition prevails, stone walls built of these boulders are a common sight (Fig. 126).

**157. Lake plains.** Glacial lakes, some of them of vast area, have been drained naturally, in recent geological history; and others have been artificially filled or drained to form extensive farm lands. These lands are called *lacustrine* or *lake plains* (Fig. 127).



Acme

FIG. 127. Farming on a Lacustrine Plain

The black muck soil of these lake bottoms, in Michigan, New York, and elsewhere in northern United States, is especially good farm land.

Lacustrine plains are usually small, though some of the larger ones, like that of former glacial Lake Agassiz, have an area of thousands of square miles. It is stated that there are about 8,000 glacial lakes in Minnesota and that about

one half of them will become farm land, by natural processes, in about 50 years.

★Michigan, Wisconsin, New York, Connecticut, and other states, once covered by the glacier, have similar lakes which will eventually become rich farm lands.

The floor of ancient Lake Agassiz is one of the levellest regions in the world. It covers the valley of the present Red River of the North, in Minnesota, North Dakota, and Canada. (See page 124.) The soil of this lacustrine plain is fine-grained and rich, so that it produces enormous quantities of excellent wheat.

Ancient Lake Bonneville, which has shrunk to the present Great Salt Lake, once occupied the eastern portion of the Great Basin. The sediments deposited in this lake, which was as large as Lake Huron, filled the valleys between north and south mountain ranges, forming many small lacustrine plains (Fig. 128).

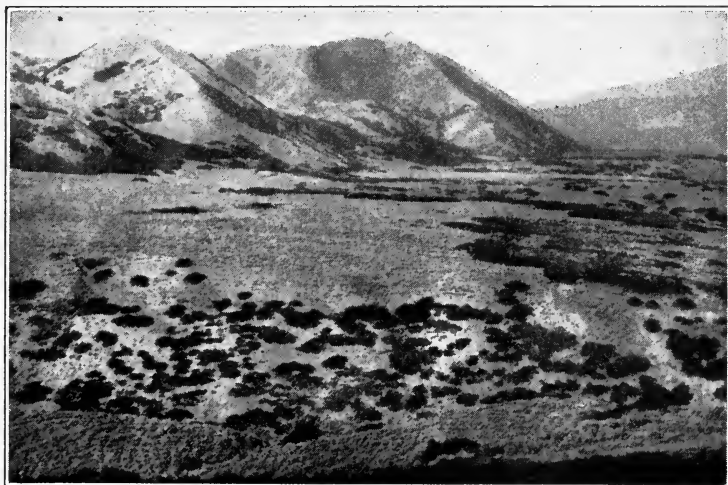

*G. K. Gilbert, U.S.G.S.*

FIG. 128. Plains of Ancient Lake Bonneville, in Utah

During the Glacial Period, the Great Lakes occupied different basins because the ice to the north blocked the natural drainage of that region. In this way, many lacustrine deposits were formed on the margins of the present lakes, which were ultimately exposed when the lakes finally receded to their present basins.

The prairies of northern Illinois are lake plains which were once covered by the waters of ancient Lake Chicago, an extension of Lake Michigan. The city of Chicago is built on this plain.

In New York State, a southern extension of Lake Ontario gave us the lacustrine plain that extends from the Mohawk Valley to Syracuse. This plain provides a favorable location for the Erie Canal and the New York Central Railroad. It was also used by the early settlers of the West as the main highway toward their new homes.

**158. Lake plains in dry regions.** Occasional heavy rains in dry regions cause great torrents to flow over the lower land and to accumulate in large, shallow, temporary lakes, called *playas*. The largest of these is in the Black Rock Desert, Nevada. It has an area of 500 square miles, but it is hardly a foot in depth. When the water evaporates, the basins are covered with fine sand and clay, sometimes mixed with crystals of salt and gypsum.

As a rule these plains are not fertile, but some of them contain valuable deposits of salt, soda, or borax, as in the Great Basin and the Imperial Valley. Sometimes these alkali plains can be made fertile by irrigation.

**159. The Great Plains.** The Great Plains occupy about the middle portion of the United States and Canada, between the Rocky Mountains and the Mississippi. This entire region was, in past geological history, repeatedly submerged by the sea, only to be finally uplifted; therefore it is of the coastal plain type, but very much modified by erosion and, more recently, by glaciation in the north.

The region of plains between the Mississippi and the Appalachians, known as the *prairies*, is characterized by tall, deep-rooted grasses, but is devoid of trees (Fig. 130).

The Great Plains are about 6,000 feet above sea level near the Rocky Mountains, and slope down gradually to the Mississippi, 800 miles away. This slope is so gradual that it is hardly noticeable. The plains east of the Mississippi rise to about 200 feet elevation near the Appalachians.

The surface covering was brought down by streams from the



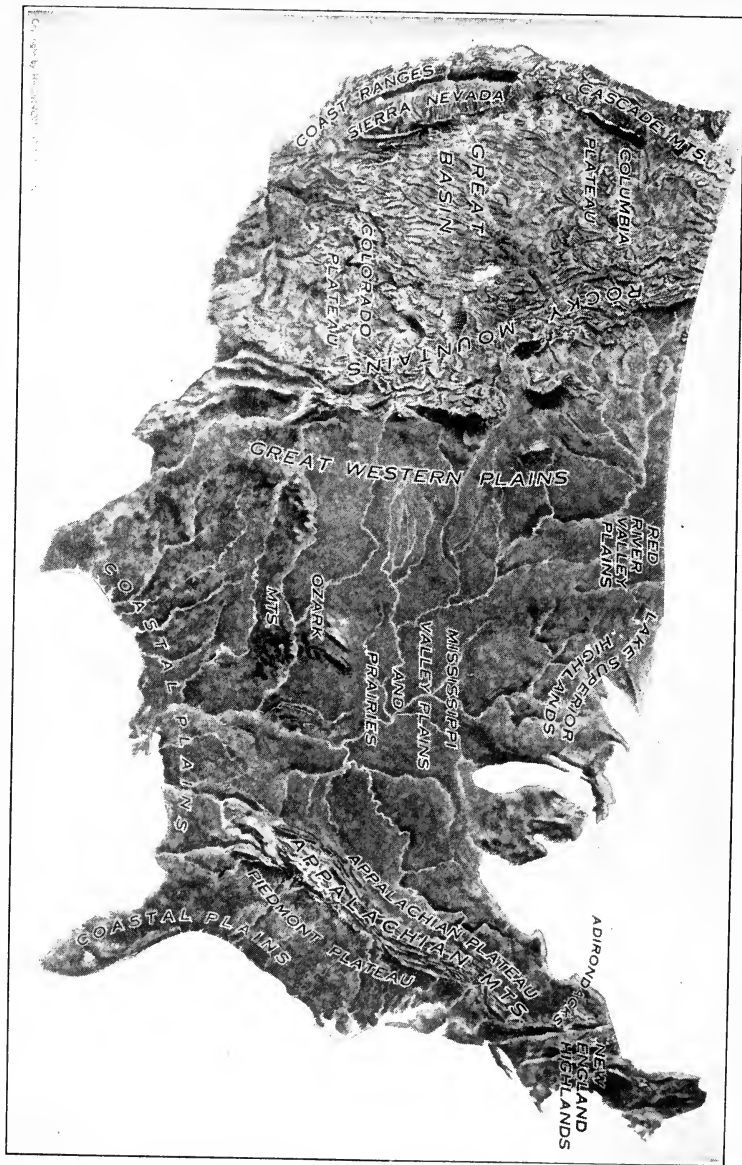

Fig. 129. Physiographic Regions of the United States

mountains on the east and west. Much of it is wind-blown and, in the north, it is to a great degree of glacial origin.

The soil is rich and easily cultivated since there is no forest, but lack of sufficient rainfall, which perhaps accounts for the absence of trees, makes it difficult or impossible to farm portions of the plains.



*Forest Service, U. S. Dept. of Agriculture*

FIG. 130. Scene on the Prairies

★160. **Erosion of the Great Plains.** In parts of the Dakotas and Montana, the soft surface deposits are being gullied so badly as to make travel in these regions extremely difficult. These regions are known as the “Bad Lands” (Fig. 131), “mauvaises terres pour traverser” as the French traders called them. A similar process of soil erosion is taking place in parts of the semiarid plains, where dry farming has removed the natural surface cover or where overgrazing has been practiced. (See *Soil Erosion*, page 57.)

161. **Economic importance of plains.** The comparatively even surface of plains makes the building of roads, railroads, and canals easier than in hilly regions and decreases the labor of the farmer. Airports are practically always established on plains.

The soil of the plain is likely to be finer, deeper, and more fertile than the adjoining higher land, since the rains carry down soluble plant food and fine sediment from the high lands.

The shallow valleys of the plain tend to keep the water table near the surface, thus rendering crops less likely to suffer from drought. It is warmer on plains than in the uplands, and the crops have a longer growing season.

All these conditions favor agriculture and development of trade, and therefore contribute to progress in civilization.



• *N. H. Darton, U.S.G.S.*

FIG. 131. The Bad Lands

Much of the land of the earth is unsuited for large populations. In tropical and subtropical lands, tropical vegetation flourishes on the lowlands, whereas at higher altitudes the crops of the temperate zone, such as wheat and barley, can be grown. Again, a plain on the wrong side of a mountain range may have a fertile soil, yet not be suited to agriculture because of deficient rainfall. Similarly, plains in the trade-wind belts suffer from lack of rainfall; and plains in the polar regions cannot be important agricultural lands because of the cold.

As a rule, the well-watered plains of the temperate zones are the great agricultural regions of the world and we are not surprised to learn, therefore, that the vast majority of the people of the world live on plains in the temperate zones.

### *Completion Summary*

Plains are of two types: plains of \_\_\_\_\_ and plains of \_\_\_\_\_.

★A peneplain is never as even as a plain of \_\_\_\_\_, because erosion \_\_\_\_\_, but leaves monadnocks.

Coastal plains are uplifted \_\_\_\_\_.

★The surfaces of coastal plains are usually fine-grained, because \_\_\_\_\_, while the layers underneath \_\_\_\_\_.

Artesian wells \_\_\_\_\_ coastal plains.

★When the Atlantic Coastal Plain was uplifted, the streams \_\_\_\_\_. Then part of the region was submerged, forming \_\_\_\_\_.

The flood plains of \_\_\_\_\_ are wide.

★The great \_\_\_\_\_ plains of the world have the densest population because \_\_\_\_\_.

Piedmont plains are formed by streams \_\_\_\_\_. Such alluvial deposits are common in semiarid regions.

Outwash plains \_\_\_\_\_ glacial drift, which has been \_\_\_\_\_ running water.

Lake plains are the bottoms of \_\_\_\_\_. Many former glacial lakes have \_\_\_\_\_, leaving the glaciated region \_\_\_\_\_.

★Ancient Lake Agassiz \_\_\_\_\_; ancient Lake Bonneville \_\_\_\_\_ Great Salt Lake.

★The Great Lakes occupied larger basins right after the Glacial Period, \_\_\_\_\_ lacustrine deposits \_\_\_\_\_.

\_\_\_\_\_ are temporary lakes in dry regions. The plains they leave \_\_\_\_\_ fertile.

★The Great Plains are the result of uplift of \_\_\_\_\_. The soil is \_\_\_\_\_, but \_\_\_\_\_. The soft surface has been badly gullied in places, forming \_\_\_\_\_. In other places, dry farming \_\_\_\_\_ and wind action \_\_\_\_\_.

The \_\_\_\_\_ of the temperate zone are the most important agricultural regions of the world.

*Exercises*

1. How are plains formed by deposition?
2. What kind of plain is formed by erosion? How?
3. How do peneplains differ from plains of deposition?
4. Explain the origin of a coastal plain.
5. Why are the rocks of a coastal plain usually horizontal?
6. Why is a layer of clay often found on top of a coastal plain, while underneath we find sandstone and conglomerate?
7. Why are artesian wells frequently found on coastal plains?
8. Explain the presence of marine fossils and wide areas of seashore sand far inland in North Carolina.
9. Why do we find sedimentary rocks in nearly every part of the earth?
10. What kind of flood plains do we find in young, mature, and old river valleys?
11. What is a piedmont plain? Name one.
12. What two types of glacial plains are there?
13. What is an outwash plain? Where is there one?
14. What is a lake plain? Name one.
15. Why are lacustrine plains very fertile?
16. Most of the plains of northern United States are lacustrine. Explain.
17. Why are playa lake basins unfertile?
18. State several reasons why plains are more densely inhabited than is hilly country.

*★Optional Exercises*

19. How can an uplifted peneplain be detected?
20. What kind of rocks are always found on a coastal plain?
21. The shore line of a young coastal plain is very regular. Why?
22. What is the extent of the Atlantic Coastal Plain?
23. What is the origin of the Atlantic Coastal Plain?
24. What is the "fall line"? Explain its significance.
25. What happened to the rivers of the east coast when the Atlantic Coastal Plain was uplifted?
26. What is the history of the Atlantic Coastal Plain?

27. Explain the presence of swamps on flood plains of old rivers.
28. Explain the dense population of delta plains.
29. Why are alluvial fans very common in arid regions?
30. To what class do the Great Plains belong?
31. What is the origin of the Bad Lands?

## CHAPTER XIII

### PLATEAUS

**162. What is a plateau?** Plateaus, like plains, have a broad and relatively even surface, but the plateau is a highland — high in contrast to some near-by lowland.

Sometimes the even surface is due to the horizontal strata underlying the surface, but in other cases, the strata are at



*N. W. Carkhuff, U.S.G.S.*

FIG. 132. Horizontal Strata of the Colorado Plateau

an angle, the flat surface having been peneplaned by erosion before it was uplifted as a plateau.

The sedimentary strata of the Colorado Plateau are horizontal, as shown in Fig. 132, while the Appalachian Plateau has underlying rocks which are tilted, and only the surface is relatively flat because the entire region was peneplaned before it was uplifted.

Although plateaus are, as a rule, higher than plains, it is not possible to distinguish between them on the basis of altitude. For example, the Piedmont Plateau, between the Appalachian Mountains and the Atlantic Coastal Plain, is much lower than the plains of the Mississippi Valley. The Appalachian Plateau has an altitude of about 3,000 feet, whereas the Great Plains, east of the Rockies, reach an altitude of 6,000 feet. They are called plains because they are relatively lower than the Rocky Mountains which are on their west, while the Piedmont Plateau is so called because it is higher than the Atlantic Coastal Plain which borders it on the east. If it were near the Great Plains, it would not be called a plateau. Low plateaus, then, are often called plains, while high plateaus, after erosion has cut them up, resemble mountains.

We may then define a plateau as follows: A plateau is a region of broad summit area that is conspicuously higher than adjoining land or water on at least one side.

The Appalachian Plateau has an elevation of about 3,000 feet, the Colorado Plateau about 8,000 feet, while the Tibetan Plateau is about 15,000 feet above sea level.

**163. Erosion of plateaus.** The cycle of erosion on a plateau is similar to that on a plain, except that the streams at the edges of the plateau are younger than on top, because of the greater slope. These young streams cut gorges into the plateau and these are the most striking features of the topography. The Colorado River has cut the Grand Canyon, which is 125 miles long and, in places, more than a mile deep. This region is still youthful.

The Appalachian Plateau (Fig. 133) is mature. Its hills are rounded, its valleys are no longer V-shaped. Why do we call it a plateau, since it is not flat like the Colorado Plateau? We have evidence that it was once flat and continuous like a plain: the tops of its numerous ridges form a straight and nearly level sky line (Fig. 133). At one time it was an erosion plain. It was uplifted into a plateau, and





M. R. Campbell, U.S.G.S.

FIG. 133. The Appalachian Plateau

Before the valley was formed, the sky line was continuous and almost horizontal.

when its old streams were rejuvenated they cut it up into mountains.

In old age, a plateau would be completely reduced to base level and would become a plain, showing no evidence of its former elevated condition. This can happen only when erosion is quite uniform. Since it is not, we find monadnocks as a feature of old regions. In humid regions these monadnocks have rounded forms like little hills, because weathering tends to wear off the edges first. But in arid regions, where weathering is at a minimum, these monadnocks retain a youthful, angular outline (Fig. 134). Such a feature is called a *mesa* (table) and a small mesa is called a *butte*. The top stratum of a mesa is usually very resistant.

**164. Climate of plateaus.** Because of their elevation, plateaus are usually cold. For example, in Mexico it is tropical in the lowlands near the coast, but temperate on the plateau. In Tibet, even in midsummer it is cold.

Most plateaus are arid. One reason for this condition is that plateaus, situated between mountain ranges, are cut off from moist winds on all sides. The winds precipitate

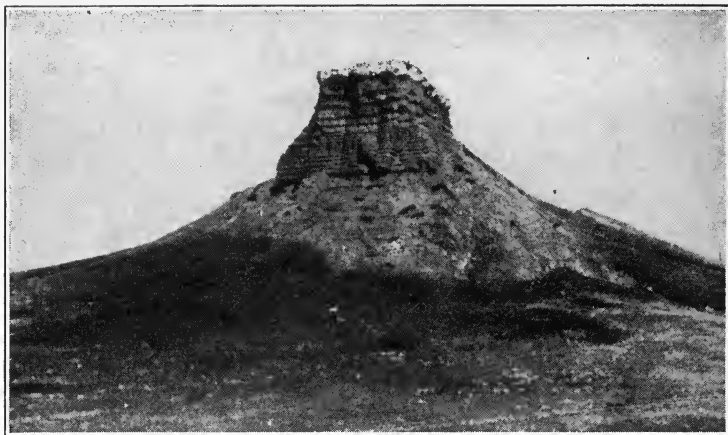

FIG. 134. A Butte

their moisture on one side of the mountains, so that when they pass over the plateau, they are dry.

The depth of the river valleys — gorges — lowers the level of ground water and still further accentuates the aridity of plateaus. Agriculture therefore does not usually flourish in such regions.

**165. Economic importance of plateaus.** The cool, dry climate of plateaus is an advantage in tropical regions. For example, the plateau of Mexico furnishes grains such as are grown in temperate regions, whereas the lowlands furnish only tropical products.

In temperate climates, however, plateaus are arid. In the plateau of Tibet, the climate is almost arctic and much of the region is abandoned to wild animals and the inhabitants are nomads.

In our own southwestern plateau region, there are a few farms near the mountains, where streams may be used for irrigation, and some other sections are fair grazing lands; but, as a whole, the region is almost unoccupied. With the growing threat of soil erosion in other sections of our country, some of these lands may be reclaimed by a more ambitious program of the Soil Conservation Service.

### *Completion Summary*

Plateaus resemble \_\_\_\_\_ in having a flat surface; but they are like mountains because \_\_\_\_\_.

A plateau \_\_\_\_\_ might be called a plain. In youth, it looks exactly like a plain, except that it is elevated \_\_\_\_\_.

Rivers on top of the plateau may be old, but on the edges \_\_\_\_\_. These \_\_\_\_\_ streams dissect \_\_\_\_\_, \_\_\_\_\_ mountains. When these mountains are rounded off and the slopes are reduced \_\_\_\_\_ maturity; and in that stage, the plateau resembles \_\_\_\_\_. The former plateau can be distinguished only by \_\_\_\_\_.

In old age, a plateau \_\_\_\_\_ plain.

In a dry region, \_\_\_\_\_ buttes.

A plateau is usually arid, because \_\_\_\_\_.

### *Exercises*

1. Explain how a plateau can have a flat surface if its bedrock consists of strata which are tilted.
2. Show how a plateau and a plain might have exactly the same elevation.
3. The Appalachian Plateau looks like mountains. Why do we call it a plateau?
4. What are monadnocks?
5. How do monadnocks differ, in humid and in arid regions?
6. What is a butte?
7. What is a mesa?
8. Explain why a plateau is usually arid.
9. Why is a plateau cold?

### ★ *Optional Exercises*

10. Describe the cycle of erosion of a plateau.
11. Explain why monadnocks in humid and in arid regions look different.
12. Show by diagram how a gorge in a plateau lowers the water table.
13. Why is it that a plateau in a tropical region may not be arid?

## CHAPTER XIV

### MOVEMENTS OF THE EARTH'S CRUST\*

★166. **Evidences of crustal movement.** There is much evidence in the hands of geologists that every part of the earth's crust has moved at one time or another, and there is a little evidence presented by history. Pliny tells us that Pompeii was on the seacoast, whereas today the ruins are miles inland. Apparently the land has risen since Pliny's time, or the sea has dropped.

The ancient temple of Jupiter Serapis at Pozzuoli, near Pompeii, is known to have been on dry land A.D. 235. When it was rediscovered in 1749, the bases of its remaining upright columns were buried in marine sediments to a depth of twelve feet above the floor of the temple. For a distance of nine feet, the *lithodomi*, or stonehouse animals, had bored holes in the columns and lived in them, causing the dark bands seen in the columns (Fig. 135).

The double caves shown in Fig. 136 were carved by waves. When the upper cave was cut out, it was in about the same position, with respect to sea level, that the lower one now occupies.

On the island of Crete there are some old docks which are now on dry land. It is evident that these must have been built in the water and that the land has risen recently.

The finding of the skeleton of a whale in the glacial gravels near Lake Champlain and the remains of other marine animals — coral, fishes, and others too numerous to mention — in the sedimentary rocks of our mountains can mean only one thing: these areas were once below sea water.

Some of these changes must have been due to sinking of the ocean bottom, which would permit the water to run off the land; others to the accumulation of vast amounts of sediment, eroded from the land and deposited in the sea, which would cause the water to overflow the land; still others to a glacial epoch, which precipitated the water, evaporated from the ocean, as snow instead

\* This entire chapter is optional.



*Ewing Galloway*

FIG. 135. Ruins of the Temple of Jupiter Serapis  
Note the rough surface of the columns due to the lithodomi.

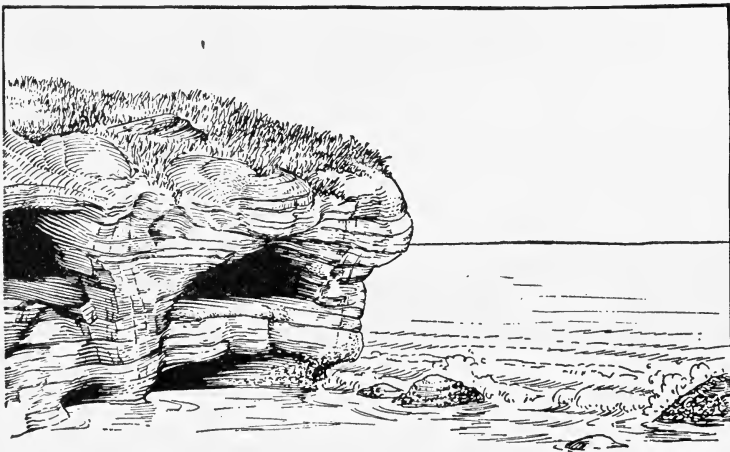

FIG. 136. Double Sea Caves, an Evidence of Crustal Movement

of water. It has been estimated that if the ice sheets of the earth today were all melted, it would raise the level of the oceans about 80 feet. And when we realize that there was much more ice on the continents during the last glacial epoch than there is today, the statement that the sea at that time was 150 to 300 feet lower than it is today is not surprising.

As we have seen in the study of rejuvenated rivers, there have been many times when entire continents were uplifted or depressed.

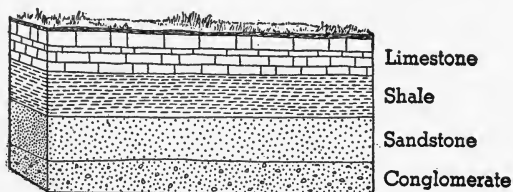

FIG. 137. Normal Succession of Sedimentary Rocks

We have furthermore the following evidence in the succession of sedimentary strata. We know that coarse material like boulders and gravel is carried only by rapidly moving streams. It follows that if we find boulders and gravel in the rocks, conglomerates, their source must have been a near-by highland. Now, the normal succession of sedimentary rocks is conglomerate, sandstone, shale, and limestone, as shown in Fig. 137, because, as the highlands wear down, the streams are unable to carry large particles and therefore the deposits get finer and finer.

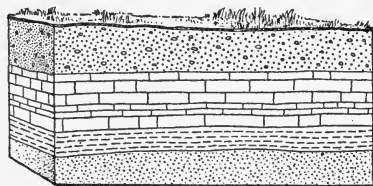

FIG. 138. Conglomerate Resting on Limestone

The limestone, which is made principally of the shells of marine animals, is formed only in clear water; this shows that the streams were so sluggish that they no longer carried even fine particles.

What then can it signify that we find a conglomerate on top of a limestone, as in Fig. 138? It is apparent that the land near by has been raised considerably to enable the rivers to carry the gravel which makes up the conglomerate.

And suppose we have a shale on top of a conglomerate? This

must mean, since the sandstone is missing, that the land was suddenly depressed. And when we examine the succession of sedimentary formations, we find all kinds of relations indicating

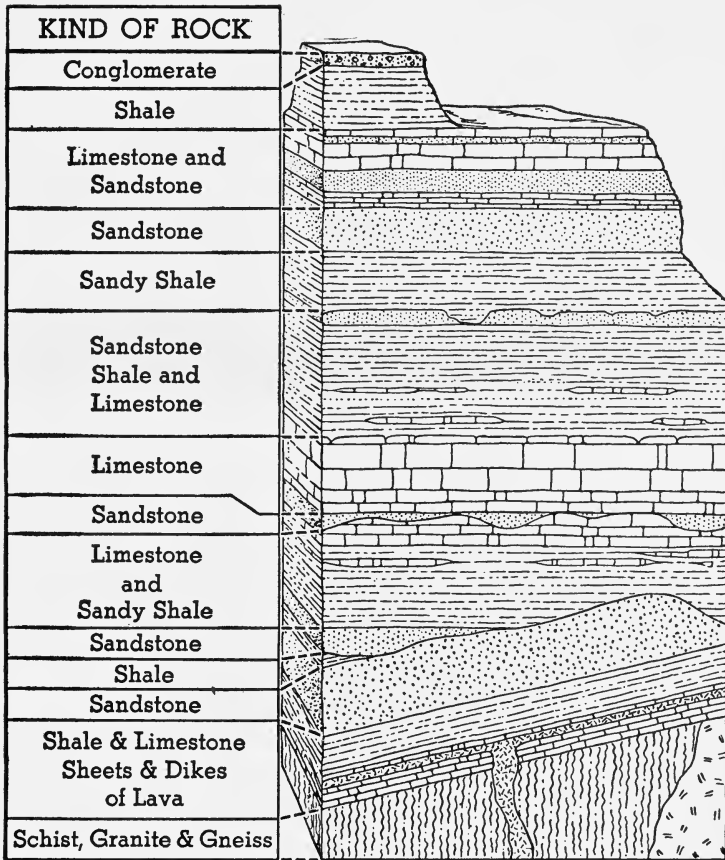

FIG. 139. The succession of strata in the Grand Canyon is evidence of many earth movements.

that the land has moved either up or down many times during the earth's history (Fig. 139).

These are all evidences of *diastrophism*, or movements of the earth's crust. These movements are usually imperceptible, requiring millions of years; but occasionally, during an earthquake, the movement is rather sudden.

★167. What is the cause of earth movements? We find the layers of sedimentary rock in most regions, not horizontal, as they were laid down, but tilted, twisted, and bent. Since the bent layers occupy less area than they did before, it follows that there

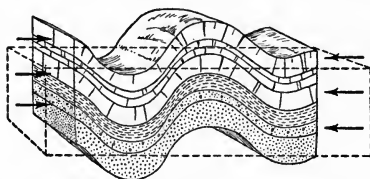
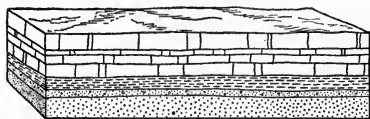

FIG. 140. Folded strata occupy a smaller area of the earth's surface than the original rocks.

has been a shortening and that the earth must have shrunk (Fig. 140). It may be, then, that the folding is due to shrinking brought about by cooling of the earth.

Another theory to account for periodic uplifts is the theory of *isostasy* developed on page 7. The sediments eroded from the mountains are deposited by rivers on the continental shelf. This causes the water to rise and flood the land. At the same time

the removal of the load from the land segment makes it lighter, while the sediments make the ocean segment heavier. Slow ad-

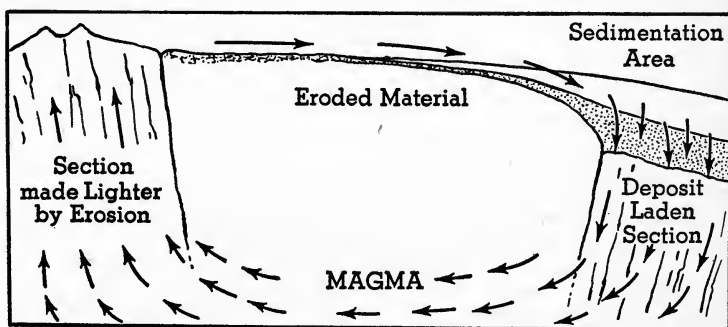

FIG. 141. The Theory of Isostasy

justment takes place, pushing down the oceanic segment and forcing up the granitic land segment.

This theory accounts for the existence of mountains parallel to the continental margins and for their elevation and re-elevation again and again. It also explains the sidewise pressure, which crumples the rocks, as due to the sinking of the oceanic wedges which squeeze the continents.



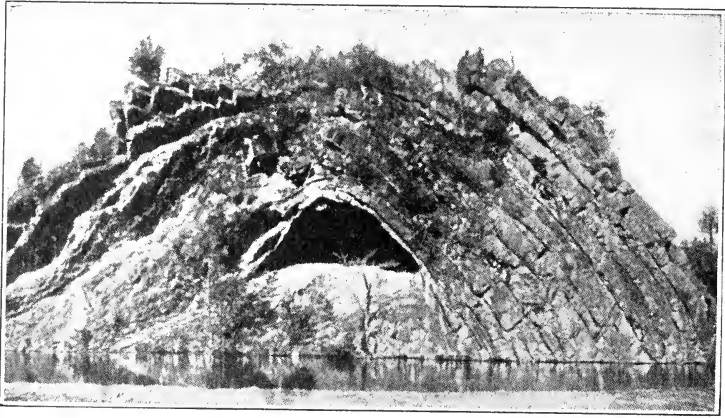

FIG. 142. An Anticline

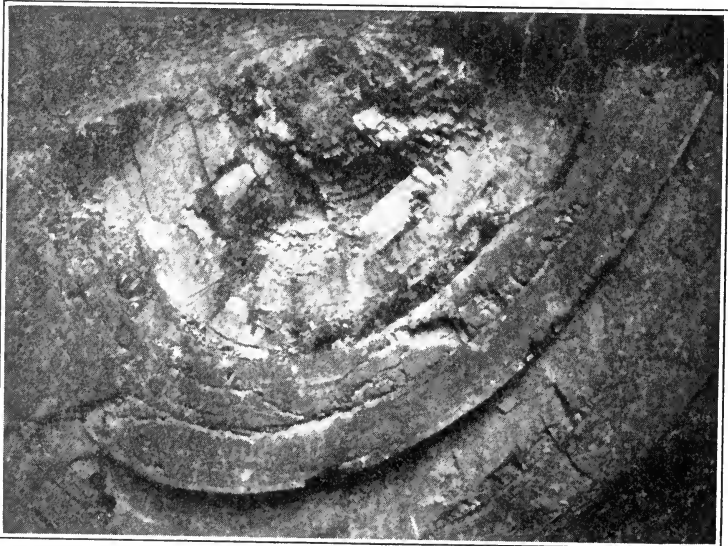

FIG. 143. A Syncline

*G. W. Stose, U.S.G.S.*

★168. **Folds.** It seems apparent that the crust of the earth cannot be elevated without being tilted unless a block is thrust straight up. On the Colorado Plateau we find nearly horizontal strata. At least they seem to be quite horizontal until followed for

miles, when it is found that there are warps or irregularities, but they are rather broad and gentle. The entire region is one *broad warp* or blister on the earth.

But much more often the strata were crumpled into *folds* when earth movements took place. Some of these folds are small enough to notice in a single view (Figs. 142 and 143), but more often one has to map the region, over many miles, before the nature of the folds is revealed.

We distinguish two parts of folded strata, *anticlines* and *synclines* (Figs. 142 and 143). When the region is first folded, the anticlines are the hills, the synclines are the valleys; and even after the region is peneplaned, we still call the structures underneath, anticlines and synclines.

Anticlines of large dimensions

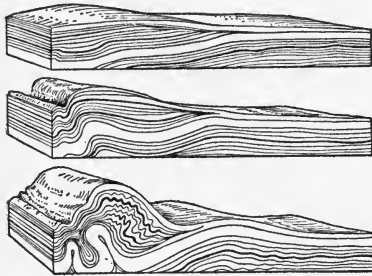

FIG. 144. Folds in Wax

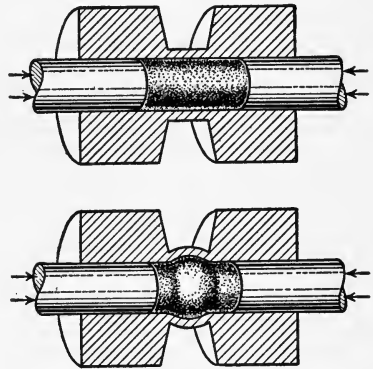

FIG. 145. A cylinder of rock confined in a close-fitting steel jacket changes its shape, without breaking, when subjected to great pressure.

are called *geanticlines*; great downward warps or troughs are called *geosynclines*.

Folds resembling those in nature have been produced in the laboratory by squeezing layers of wax or clay in a vise. Some of these are shown in Fig. 144.

Ordinary rocks are brittle and when subjected to compressional forces they change their shape slightly, but finally break and fly to pieces when the pressure becomes excessive. But when the specimen is confined in a steel jacket, it cannot break but apparently flows (Fig. 145). The conditions of this experiment are much like those in the crust of the earth where the underlying rocks, confined on all sides, are under enormous pressures.

★169. **Joints, fissures, and faults.** Near the surface of the earth, therefore, we have cracks in the rocks just as we should expect, while down below, because of the pressure, cracks become smaller and smaller and finally disappear entirely.

We find fissures developed very often in anticline structures and rarely in synclines. The anticline is under tension, which pulls

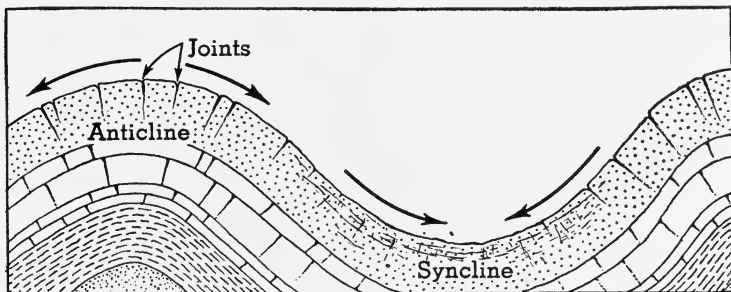

FIG. 146. Joints are formed in anticlines during folding, because of tension.

the rock apart, while the syncline is under pressure, which closes up any joints rather than develops new ones (Fig. 146). During erosion, therefore, the anticlinal structures are more easily breached and worn down, and it follows that mountains are often synclinal in structure.

If the crack is merely a small separation of the walls of rock, it is called a *joint*; if there is a distinct separation (an actual gap), it is called a *fissure*. If besides separating, there has also been motion parallel to the crack, it is called a *fault* (Fig. 147).

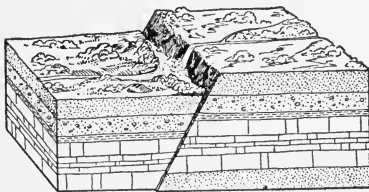

FIG. 147. A Fault

The block on the left has dropped, developing a waterfall.

Many igneous rocks are jointed into large blocks which give the impression of stratification (Fig. 19). The joints were formed by uniform cooling of the mass, and they are always at right angles to the cooling surfaces. Such jointing is called *columnar structure*. It accounts for the Palisades of New Jersey and the Giant's Causeway of Ireland, where the igneous mass was horizontal, making the joints vertical.

Faulting often produces a repetition of strata on the surface (Fig. 148), and when we find such a repetition, we suspect a fault.

Folding also produces a repetition of strata on the surface, but the arrangement is different (Fig. 149). After erosion has planed down the fold structures, the anticline shows a repetition of strata like *ABCBA*; and the syncline, *CBABC* where *A* is the youngest stratum and *C* the oldest.

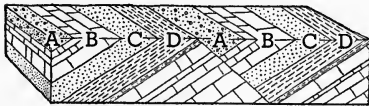
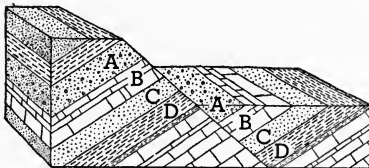
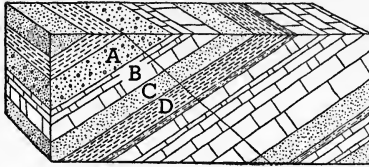

FIG. 148. Repetition of Strata Due to Faulting

The upper block shows the rock before faulting. The middle block shows the result of faulting. Erosion then wears down the fault scarp on the left, leaving the peneplaned surface, as in the lowest block, with a repetition of strata.

When the displacement on a fault is vertical, the one side stands higher than the other, leaving a *fault scarp* or cliff

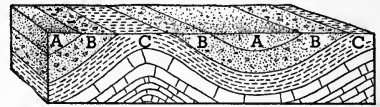
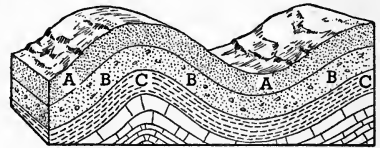

FIG. 149. Repetition of Strata Due to Folding

Compare the order of repeated strata here, *ABCBA*, with that in Fig. 148, *ABCDABCD*.

(Fig. 147). This forms one kind of mountain, called a *block mountain*, examples of which are found in the Great Basin of western United States.

It seems well established that the cause of folding and faulting is sidewise pressure. On the surface the rocks crack and fault, but in depth they fold, especially when the overlying pressure is great and when it is applied very slowly so that the rocks can adjust themselves.

Sudden movements of the earth's crust manifest themselves as earthquakes.

### *Completion Summary*

There is evidence that the land has risen or the sea ——— many times in geological history. There is even ——— human history.

The normal succession of sedimentary strata is conglomerate, ———, ———, with limestone at the top. This is so because, starting with a highland, the streams can carry ———, which ultimately forms ———. As the highland is worn down, the sediments become finer, until at last, when the highland is entirely worn down to a peneplain, ——— sediment is carried, the waters become clear, and ——— is formed on top of all the sediments brought down from the former highland.

We believe earth movements are an ——— adjustment, caused by deposition of great weights of sediment on the continental shelf.

Crustal movements cause ——— of the strata into anticlines and ———. When the forces are too great, the rocks are broken, forming ———.

Joints are ——— in the rocks, whereas ——— are actual separations. Fissures are usually developed in anticlines, while in synclines, ——— because ———.

Uniform cooling of a mass of igneous rock forms joints, at right angles to the cooling surface. This is called ———.

A fault scarp is caused by ———. On a large scale, a fault scarp ——— block mountains.

### *Exercises*

1. What historical evidence is there that the land has changed its elevation?
2. Explain how a glacial epoch would cause a difference in elevation of the land with respect to sea level.
3. Why do we estimate that the sea was over 150 feet lower during the Glacial Period than it is today?
4. How would the deposition of vast amounts of sediment in the sea affect the sea level?
5. What does a rejuvenated river prove about crustal movement?

6. Show how the character of sedimentary strata changes from coarse to fine with the elevation of the source of the sediments.

7. Limestone on top of sandstone is evidence of what crustal movement?

8. Shale on top of sandstone indicates that something has happened to the near-by highland. Explain.

9. What does a limestone stratum indicate regarding the near-by land?

10. What is indicated by a great thickness of limestone?

11. Explain why we have much thicker layers of limestone than of conglomerate.

12. What is diastrophism?

13. State and explain the theory of isostasy.

14. What is a fold? Show by diagram.

15. What is a broad warp? How does it differ from an ordinary fold?

16. What is an anticline? a geanticline?

17. What is a syncline? a geosyncline?

18. Explain how rocks may fold without breaking.

19. Why are joints developed near the surface?

20. Explain why there are often fissures in anticlines but not in synclines.

21. Explain why mountains are often synclinal.

22. How does a fissure differ from a joint?

23. What is a fault?

24. What is columnar structure?

25. How can we tell a fault by repetition of strata on the surface?

26. How can we tell that the underlying strata are folded into an anticline? a syncline?

27. What is a fault scarp?

28. What is believed to be the cause of folding and faulting?

## CHAPTER XV

### MOUNTAINS

**170. What are mountains?** When plateaus are dissected they become mountains. The plateau has a large summit area, while the mountain has a small area at the top, forming a peak. On the one hand, then, plateaus resemble plains in that each has an extended flat top; on the other hand, we find plateaus resemble mountains in that each is at a high altitude.

Some mountains, like Pikes Peak, consist of a single sharp summit or peak; others consist of long ridges. A *ridge* has much greater length than breadth.

A *mountain range* is a ridge or a group of parallel ridges. A *chain of mountains* is a group of parallel ridges. A *cordillera* is a group of mountain chains; for example, the Cordilleras of western United States include the Rocky Mountain chain, the Sierra Nevadas, and the Coast Range.

There is a widespread belief that mountains are very, very steep, with slopes approaching  $90^\circ$ . The average slope is not more than  $20^\circ$  except near the top, where it may be as much as  $40^\circ$ . The impression of steepness is probably given by the fact that the incline is not continuous but is broken up into steps, each of which may have a very steep slope. In climbing up the mountain, one can see only one of these steps at a time and that leaves the impression of  $90^\circ$  slopes.

**171. Distribution of mountains.** As we have already seen (page 196), all great mountain ranges are formed near the borders of the continents, parallel to the oceans, and the highest mountains are near the deepest ocean, the Pacific: for example, the Andes and the Rocky Mountain

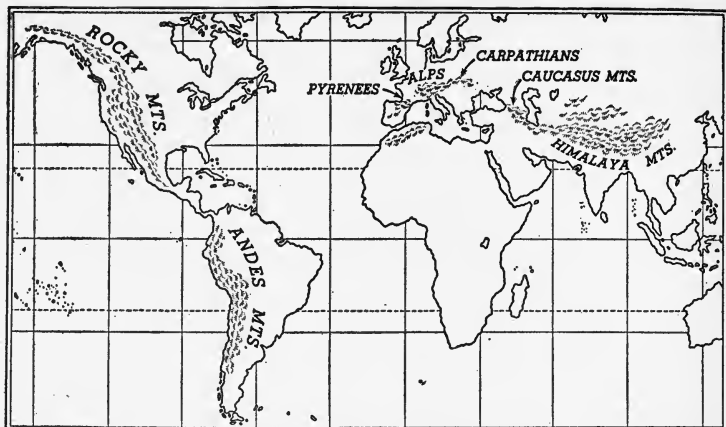

FIG. 150. The Four Great Cordilleran Regions

systems in South and North America, and the Himalayas in Asia.

There are four great cordilleran regions.

1. The North American Cordillera
2. The Andes of western South America
3. The southern European Cordillera
4. The Asiatic Cordillera

The North American Cordillera includes the Rockies, the Sierra Nevadas, the Cascade and Coast Ranges, the Basin Ranges, and the coast ranges of British Columbia and Alaska. The Andes are really the natural continuation of the North American Cordillera.

The cordillera of southern Europe includes the Alps, the Pyrenees, the mountains of Spain and northern Africa, and the Carpathians.

The Asiatic Cordillera includes the Himalayas, the Kunlun and Hindu Kush, and Caucasus Mountains.

**172. Origin of mountains.** The more important processes by which mountains have been formed are shown in the following table.



PROCESS	TYPE OF MOUNTAIN	ARRANGEMENT
1. Eruption	Volcanic cone	Single peak or groups of peaks
2. Intrusion	Dome mountain	
3. Erosion	Dissected plateau Monadnock	
4. Faulting	Block mountains	Mountain ranges
5. Folding	Folded mountains	
6. Combined	Complex mountains	

**173. Volcanic cones.** During the eruption of one type of volcano, a large amount of rock material is hurled into the air, where it cools rapidly and is already solid by the time it falls. This volcanic ash is very irregular in shape and forms a steep conical hill around the crater (Fig. 151). This

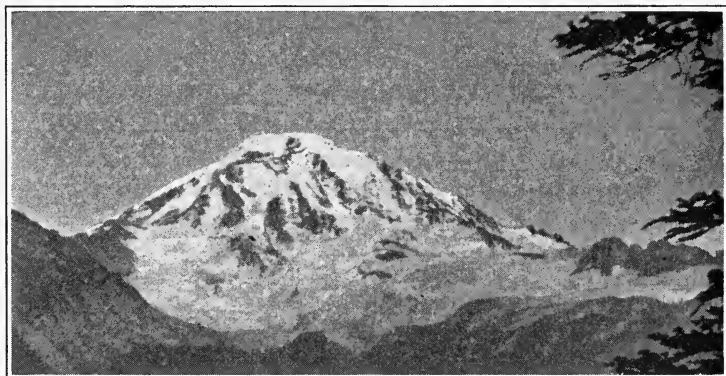

*B. Willis, U.S.G.S.*

FIG. 151. A Steep Volcanic Cone

volcanic cone is gradually built up, higher and higher, by successive eruptions until a mountain is formed. Mt. Rainier in Washington, Lassen Peak in California, Vesuvius in Italy, Fujiyama in Japan, and Aconcagua in Chile are good examples of volcanic cones. Aconcagua is 23,000 feet high.

Some of the Hawaiian volcanoes rise 30,000 feet above the ocean floor, with a circumference of 100 miles at sea level, and are very symmetrical. These volcanic cones, in

other words, are not steep like the former, because they do not hurl their ash into the air; but the lava flows out quietly as a liquid, and therefore spreads out much more before it solidifies.

**174. Dome mountains.** Some igneous intrusions, called laccoliths, never reach the surface but bow up the strata of overlying rocks by reason of the great pressure from beneath. The strata are not folded but simply raised up into a dome.

The Henry Mountains of Utah (Fig. 152), the Black Hills of

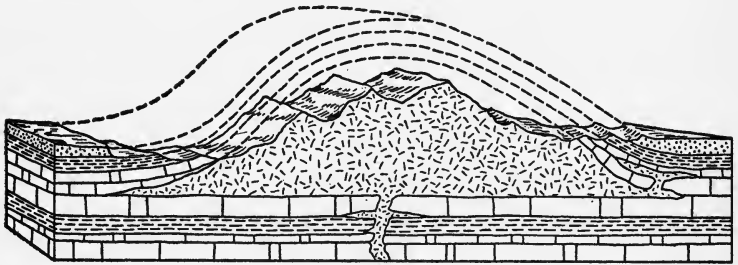

FIG. 152. Section of the Henry Mountains, Showing How the Igneous Intrusion, Forced up from Below, Domed up the Strata

These strata have since been eroded, exposing the igneous mass.

South Dakota, and the Elk Mountains of Colorado are dome mountains.

The surface strata above the dome are usually cracked during the uplift. Since they are sedimentary rocks, which are not very resistant, and because they are at a greater altitude, they are eroded rapidly, exposing the igneous mass — laccolith — underneath (Fig. 152).

**175. The dissected plateau.** We have already considered the cycle of erosion on a plateau, page 188. As the young streams cut gorges into the plateau, weathering of the edges along the tops of the gorges widens them until the region loses its plateaulike appearance and is cut up into mountains (Fig. 153). The Catskill Mountains of New York and the Appalachian Mountains are both dissected plateaus.

The final stage of the dissection of a plateau changes the region into a plain, with monadnocks in humid regions, and buttes and mesas in arid regions.

Lookout Mountain is a remnant of an old plateau and the "temples of the Grand Canyon" (Fig. 9, page 13),

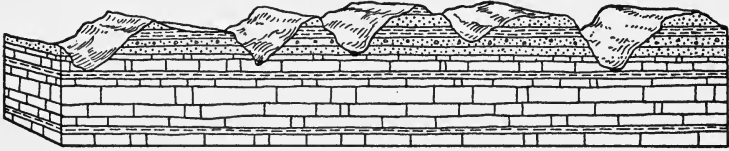

FIG. 153. Mountains Formed by Dissection of a Plateau

some of which are over 5,000 feet high, were formed by dissecting a plateau.

**176. Block mountains.** In the Great Basin there are ranges of such simple structure that their origin is clearly shown. They were formed by a series of great faults. Figure 154 shows the structure of three of the ranges, *A*, *B*, and *D*.

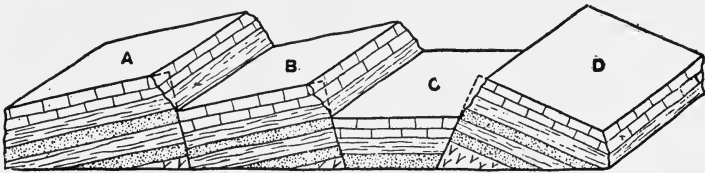

FIG. 154. Diagram of Block Mountains

The bedrock was evidently faulted, perhaps by a stretching force. Since the entire region is bowed up into one broad warp without much folding, the top of the anticlinal structure would be subject to stretching and would therefore crack. This is shown by the dropping down of the wedge-shaped block, *C*.

Block mountains have a short, steep slope on one side and a long, gentler slope on the other side, with the strata parallel to the gentler slope.

In southern Oregon there are many block mountains that

were formed so recently (geologically speaking) that erosion has not yet notched their summit lines; and the frequent earthquakes of the region are further evidence that the faulting which accompanies mountain making is still going on.

The block mountains of Nevada and Utah are older and much eroded. The summits are notched and uneven and the slopes are scarred with deep ravines. Some of the ranges are 80 miles long and 20 miles wide and their summits rise from 2,000 to 7,000 feet above the valleys.

**177. Folded mountains.** The great mountain chains of the world are records of former crustal movement or displacements of the rocks resulting from enormous compressing or uplifting forces, already studied (page 196).

The surfaces of young mountains are always covered by thick layers of sedimentary rocks, indicating that it is always a great trough, filled for a long time by an arm of the sea, which is finally uplifted and folded into mountains.

★Underneath the sedimentary rocks we always find metamorphic and igneous rock, chiefly the former, making up the core of the mountains. This would seem to indicate the enormous forces engaged in the mountain-making process: great pressure and heat, causing violent movements and accompanied by igneous activity from the depths of the earth, are some of the factors that bring about the change of rocks which were originally igneous into rocks which are now metamorphic. Often, too, this igneous activity has brought up, from the depths, metals and their ores, so that mining as an industry is confined chiefly to mountains or areas that were once mountains.

★**178. The Jura Mountains.** One of the best examples of simple folded mountains is the Jura Mountains of France. They consist of a series of ridges of sedimentary rock containing marine fossils. The rocks were originally horizontal, since all sediments are laid down that way; but they are now bent and folded into a series of anticlines and synclines (Fig. 155). Most folded mountains also show faulting.

The Jura Mountains have been only slightly eroded. The upper

layers on the tops of the ridges have been removed and spread over the valley floors; but the mountains are still young.

★179. **The Appalachian Mountains.** The folds of these mountains are not at all like the simple curves of the Juras. In the



FIG. 155. Cross Section of the Jura Mountains

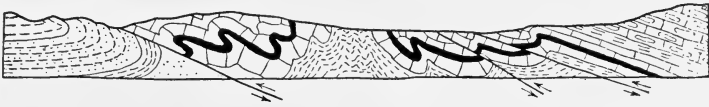

*By the U.S.G.S.*

FIG. 156. Cross Section of the Folds and Faults of the Southern Appalachians

southern Appalachians the folds have been crowded together and faulted. In some of these faults the displacement is several thousand feet (Fig. 156).

Examine Fig. 157, which is a cross section of the Appalachian

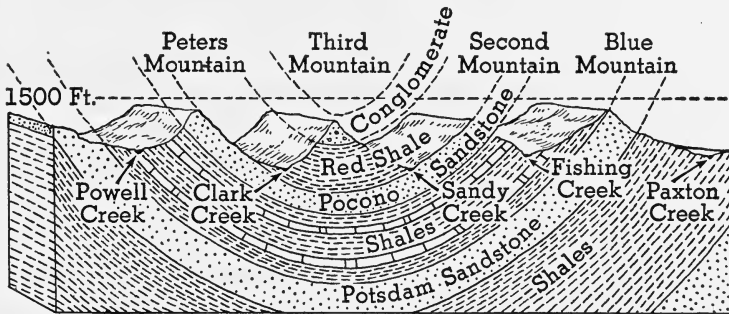

FIG. 157

folds. The Pocono sandstone, a resistant rock, forms the summit of Peters Mountain, and of Second Mountain, and, from the dip or inclination, it is apparent that the Pocono sandstone forms a synclinal fold underneath Third Mountain.

If the strata were continued, as is indicated by the dotted lines, we should have a diagram of the anticlines that formed the ances-

tral Appalachian Mountains, a range which probably resembled the Alps in grandeur and elevation (Fig. 158).

If the continuation of these lines were actually carried out, to scale, it would appear that the ancestral Appalachian mountains were perhaps ten miles high, which is not borne out by other evidence. We must remember that the process of mountain mak-

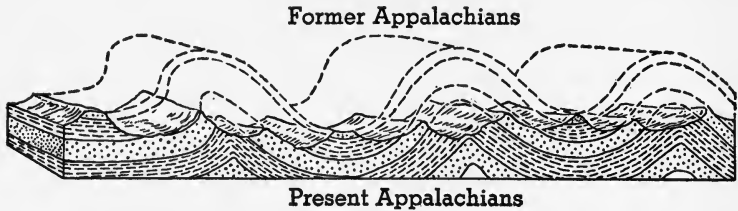

FIG. 158

ing may take many millions of years and while it is going on, *erosion is also going on* and cutting down the highest places. These two processes, working against each other, produce the actual mountains, whereas, if there were no erosion at all, it is possible that some of our mountain ranges would be ten to fifteen miles high.

Although three and one half miles of rock have been eroded from the top of the Uinta Mountains, it is probable that they have never been much higher than they are at present.

It may seem strange that the tops of the present mountains are synclinal in structure rather than anticlinal, because when they are formed, the anticlines form the mountains, while the synclines are the valleys, as is the case with the Jura Mountains (Fig. 155). But we must remember that during the folding the tops of the anticlines are cracked, and hence easily eroded; while the synclines consist of firm, dense rock, because there the strata are compressed and all cracks closed up. Erosion of running water and frost action quickly wear through such anticlines, while the synclines, having few, if any, cracks are worn much more slowly. If this process continues long enough, the synclines will be at the same level as the anticlines, and we shall have a peneplain (Fig. 159).

If this peneplain is elevated, the former anticlines will

again begin to wear more than the synclines, and we shall in time have a dissected plateau in which the synclines are the mountains and the anticlines are in the valleys.

If we were standing on the top of Blue Mountain (Fig. 157), looking west over Second, Third, and Peters Mountains, we should see that these mountain tops are at about the same level. If the valleys between the mountains were filled, a plain would be formed which would slope gently toward the east. (The dotted line in the figure is horizontal.) The evidence shows that the ancestral Appalachian Mountains were originally uplifted in great folds; they were then peneplaned, uplifted as a plateau, and it is this plateau which has since been dissected to form the present mountains.

The ancestral Appalachians were folded mountains, formed by a lateral thrust that acted westward from the Atlantic coast. The present Appalachians were formed by erosion made possible by a vertical force which elevated the region, after it had been peneplaned, into a plateau.

★The ancestral Appalachians were uplifted at the end of the Paleozoic Era, about 180 million years ago, and the peneplaned mountains were re-elevated at the end of the Mesozoic, about 60 million years ago.

The top of Third Mountain was once the bottom of a great valley or syncline; hence it is called a *synclinal mountain*.

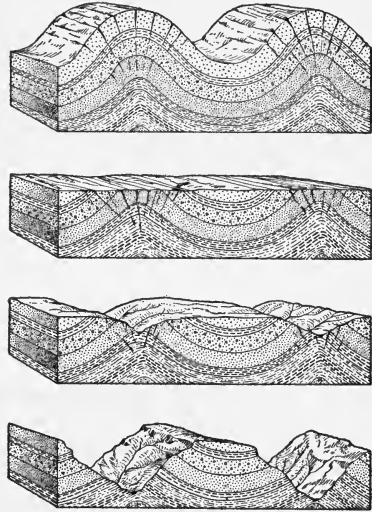
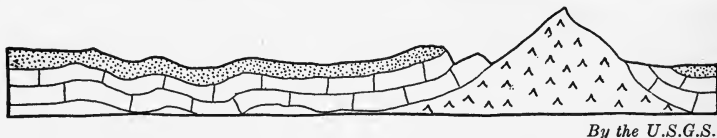

FIG. 159. Development of a Synclinal Mountain

Starting with the uppermost block, the anticlines are eroded rapidly, and even when the region is peneplaned and then re-elevated, the anticlines continue to erode faster than the synclines, until in the lowest block we have a synclinal mountain.

The Appalachians are mature mountains with rounded and well-forested tops.

**180. The Rocky Mountains.** Like all great mountain systems, the Rocky Mountains were formed from thick sediments that accumulated in a great synclinal trough in the bottom of the sea, which then covered interior North America. During the uplift there was some folding, but it was not nearly so intense as in the case of the Appalachians (Fig. 160). Apparently there was some pressure from the



*By the U.S.G.S.*

FIG. 160. Cross Section of the Rocky Mountains

side, but the chief force was vertical, so that the strata are not badly folded and crushed.

The core of the mountains is made of granite and other similar igneous rocks. On either side of this core are layers of sedimentary rocks which have been pushed up by the granite.

★The Rocky Mountain uplift occurred at the end of the Mesozoic Era, about 60 million years ago, and has continued into recent times. It is probably still going on.

The Rocky Mountains are young mountains, with rugged peaks which make a very irregular sky line. The name comes from the rocky tops of the mountains, many of which are above the timber line and therefore bare (Fig. 161).

**181. The life history of mountains.** The life history of mountains follows closely that of rivers; and we may sum up the characteristics of young, mature, and old regions as follows:

CHARACTERISTICS OF MOUNTAINS IN YOUTH

Example: Rocky Mountains

1. Lofty elevation
2. Rugged — irregular sky line. Good scenery



3. Steep slopes with little talus
4. Young streams, often torrential, with deep ravines
5. Avalanches, landslides, and earthquakes occur.



*B. Willis, U.S.G.S.*

FIG. 161. Scene in the Rocky Mountains

#### CHARACTERISTICS OF MATURE MOUNTAINS

Example: Appalachian Mountains

1. Elevation not very high
2. Rounded tops, well covered with vegetation
3. Uniform slopes with much talus
4. Mature streams. Water gaps appear.
5. Avalanches rare. Earthquakes unknown

#### CHARACTERISTICS OF OLD MOUNTAINS

Example: New York City

1. Low elevation, approaching the peneplain
2. Monadnocks stand out.
3. Region rather flat with low, rolling hills
4. Streams old

There is, of course, no sharp line of division between the three stages in the life history of mountains and it is possible to add other subdivisions such as early youth, late youth, early maturity, etc.

The uplift and decline of mountains takes place so slowly that the change produced during one's lifetime passes unnoticed, and men have come to think and speak of mountains as everlasting. History gives us no assistance either. Polybius's description of the Alps as they were when Hannibal crossed them in 218 B.C. is practically a description of the Alps today. They are still young mountains and the lapse of 2,000 years has not changed them noticeably. It is evident, then, that the life history of mountains cannot be expressed even in thousands of years. The Rocky Mountains, which were formed, we believe, about 60 million years ago, are still young.

**182. Climate of mountains.** The snow-capped mountains of the torrid zone exemplify, upon their slopes, all the climatic changes that one would experience in traveling from the torrid zone to the polar regions. As one ascends, the palms and bananas of the torrid zone gradually disappear and are replaced by the deciduous trees and wild flowers of the temperate zone. These, in turn, are replaced by the cone-bearing trees, which, as the ascent is continued, become low and dwarfed; finally all trees disappear farther up, and the snow-clad top is a frigid zone in miniature. In a similar manner the forms of animal life that inhabit the bases of such mountains gradually disappear and are replaced by forms resembling those that characterize the colder parts of the earth.

The great variety in mountain climate is due to the fact that the temperature gradient in air at rest is more than 1,000 times as great as the horizontal temperature gradient. That is to say, the temperature, as one ascends, decreases more than 1,000 times as fast as it does when one travels toward the pole.

The *timber line and snow line* are more or less irregular, being higher on the sunny side than on the shady side. In the equatorial region, the snow line is about 18,000 feet above sea level, but its altitude diminishes as the distance

from the equator increases, reaching sea level at the polar regions.

Many ranges are subject to excessive rainfall or snowfall on the windward side, and where they cross prevailing winds, the climates of the opposite slopes are quite different. For example, on the western slope of the Sierra Nevadas the moist wind is chilled as it rises, and thus it produces abundant rainfall, which supports forests, whereas the same wind on the eastern slope, having lost much of its moisture and being heated as it descends, becomes a drying wind which takes moisture from the land and makes it arid.

**183. Influence of mountains on man and history.** Because of the difficulty of crossing mountain ranges, the difference in climate on the different sides, and the military advantages which they afford, mountain ranges are the natural boundary lines for nations. The Himalayas, which separate different races; the low Pyrenees, crossed by few roads and railroads; the Caucasus, the Alps, and the Andes, all illustrate the tendency of nations to select mountain ranges for their frontiers.

As the Indian and the pioneer gained a measure of security within their stockades, so a nation surrounded by mountain ramparts feels secure from outside interference. Their elevation enables scouts to see an approaching enemy who would be invisible on a plain, and this diminishes the chance of surprise. Narrow passes, well fortified, can be successfully defended against vastly superior numbers because the invading army cannot approach the pass in line of battle and is met in small parties. The famous defence of Thermopylae by the ancient Greeks illustrates this advantage.

The soldier on the mountain meets a tired foe, and in hand-to-hand conflict this is an important aid. Artificial avalanches of boulders have frequently decimated armies attempting to cross mountain passes. When Hannibal crossed the Alps, his losses through this kind of warfare contributed in no small measure to his ultimate defeat.

Because of the security afforded, conquered races usually make their last stand in mountains and have frequently been able to maintain their position through long periods. Some of these peoples have maintained their individuality even to the present day, as the Basques, the Welsh, and the Scotch Highlanders.

With the military advantage comes a degree of isolation which favors the development of a distinct type of civilization and an individual language, or dialect, in the region thus set apart from the rest of the world. This tendency is illustrated in the many small principalities which developed in Europe during the Middle Ages, several of which exist today; and by the fact that, in the California valleys, there were almost as many tribes of Indians having characteristic languages and customs as there were valleys between the mountains.

The same isolation limits commerce and knowledge of the outside world, and compels the residents of mountainous regions to depend upon themselves for their wares and for their progress. If their number is small, as it is apt to be on mountain slopes where the struggle for existence is so strenuous, there is rarely progress in the ways of civilization, but instead there is often a retrograde movement. Mountaineers are proverbially conservative, using the same processes and following the same customs that their ancestors used and followed. In the southern Appalachians we find excellent illustrations of this effect; here are peoples following habits and customs of the eighteenth century. Mining cities in mountains are exceptions. To them, the sudden wealth brings all that is good and all that is bad in our modern civilization.

**184. Mountains as barriers.** Several conditions make it difficult even for man to cross high mountains. (1) The steep slopes at low elevations are hard to climb; those at high elevations are worse because of the thin air. (2) More serious conditions are the low temperature, the penetrating wind, and the driving snowstorms, followed by the blinding

glare of the sun. (3) Avalanches and landslides sometimes bury whole caravans in the Himalayas. In our own Cascades, an avalanche carried away an entire train of Pullman cars. (4) Doubtless the most dangerous mountain road in the world is the caravan route from India into western China. For several days' journey the route is above the timber line, where no grass can grow and where it is so cold that there are no inhabitants. Thousands of horses have been lost in this section through cold and hunger.

Even the minor mountain ranges retard the exploration and settlement of a region.

Mountain ranges are watersheds and rivers rarely cross them. The explorer who wished to cross them was obliged to obtain horses or carry his supplies on his back. This required complete reorganization of a party that was equipped to travel by canoe, and often caused the explorer to turn back.

If an explorer follows rivers, shelter and food for many weeks may be carried in a canoe by one man; if he journeys over plains, he must carry food for his horses and the men who care for them—as well as for himself; if he is to cross mountains, pack animals must be substituted for wagons, with further increase in the size of the party.

There is no better illustration of this retarding action than that found in the early history of this country. Before the year 1600 European explorers had discovered the mouths of the St. Lawrence, the James, the Mississippi, and the Rio Grande, and had visited California. During the next century the English explored and settled the Atlantic Coastal Plain, but made few attempts to cross the low ridges of the Appalachians; the French, during the same period, explored the St. Lawrence and followed the Mississippi to the Gulf. They established settlements along these routes, which grew into towns still bearing French names, such as Detroit, Sault Ste Marie, Fond du Lac, Prairie du Chien, St. Louis, and Baton Rouge. The Spanish settlers on the Gulf of Mexico, during the sixteenth and seventeenth centuries,

extended their missions toward the north as far as Sante Fe, where the Rocky Mountains checked further progress in this direction. They therefore pushed westward to southern California. From there they followed the Pacific coast toward the north, establishing missions in the narrow area between the Coast Range and the Pacific. Their trail is now marked by cities still having Spanish names, such as San Antonio, Sante Fe, and, along the coast, San Diego, Los Angeles, San Francisco, Sacramento, San José, and San Luis Obispo.

The Berkshire Hills, in Massachusetts, exerted an important influence in settling the contest between Boston and New York City for commercial supremacy. Freight brought from the west through the Mohawk Valley to Albany could be brought to New York by boat more cheaply than it could be hauled over the Berkshires by teams, and much of it was naturally deflected to New York. When railroads were built along the Hudson and through the Mohawk Valley, New York City acquired further advantage over Boston because of the Berkshires. Before a railroad line from Albany to Boston was completed, the position of New York as the chief seaport of the United States was fully established.

Mountains are not absolute barriers. They are difficult to cross; but when sufficient incentive is provided, men always succeed in crossing them.

In the case of the English colonists the necessary incentive came in the demand for more room and more virgin soil and in the increased importance of the trans-Appalachian fur trade. During the French and Indian War the possession of the best passes through the mountains was stubbornly contested, as is shown by the large number of battlefields between the Hudson and Lake Champlain, and between the Mohawk and Lake Ontario.

The Rocky Mountains retarded the settlement of California more effectively than the Appalachians confined the

colonists to the Atlantic coast, and for a longer period, because of their greater height and breadth; but the necessary incentive came in the discovery of gold in 1848. Before the close of 1849 there were 100,000 people in California.

**185. Mountain industries.** The excessive cost of transportation in mountainous regions is so serious a handicap as to render manufacturing unprofitable when in competition with manufactories located on plains, unless the mountaineer can find his raw material on the mountain and can convert it into a light finished product of greatly increased value. Thus lumber grown on the mountain is made into carvings and souvenirs and sold to tourists, entirely eliminating all cost of transportation.

In mining regions the handicap is less important than elsewhere, because the product is so valuable. The few dollars' worth of gold obtained from a ton of ore can be carried down the mountain in one's pocket.

**186. Mining.** One of the reasons why mining is so important among mountain industries is that igneous rocks are so often found in the center of the mountain mass as shown in the cross section of the Rocky Mountains (Fig. 160). Certain valuable ores are found in these deposits of igneous rock, others occur in rocks metamorphosed by contact with the igneous rocks, and still others are found in fissure veins or in porous rocks through which ground water has circulated.

A second reason for the importance of mining in mountain regions is the ease with which the kinds of rock forming the mountain are discovered. On plains, the kind of rock underground can be determined only by boring. On the mountain, where streams cut gorges *across* the strata, the structure and the kinds of rock are revealed. In the United States we obtain a large percentage of the supply of gold, silver, copper, iron, lead, zinc, and anthracite coal from mountain mines. Much marble, slate, and granite are quarried in mountains.

Bituminous coal, salt, rock phosphate, and some iron ores occur in sedimentary rocks. These ores are mined in plains as well as in mountains.

Figure 162 shows the location of the gold and silver mines of the United States. Gold mines are found in the Appalachian Mountains, in the Black Hills, and in the western mountains. Silver mines are all located among the ranges of the Western Cordillera. Compare this map with Fig. 150 to determine the position of the mines with respect to mountains.

Can you suggest a reason for the large number of mines along the eastern boundary of California?

**187. Water power.** The water power of mountain streams has long been utilized in cities along the fall line and by the miners of the western mountains, but only a small percentage of mountain streams can be thus utilized. The possibility of electric transmission of power has greatly increased the value of these streams; and the public interest in the "white coal," as water power is called, speaks for its rapid development. It is destined soon to become a second important industry in the mountain regions and a great stimulus to our manufactures.

The amount of power that can be obtained from a given fall depends upon the weight of the water per minute and upon the vertical distance that the water falls. The product of these two numbers gives us the theoretic number of foot-pounds of work that the fall can produce; but this number can never be obtained since no water wheel is 100 per cent efficient.

If the flow of a stream were uniform throughout its course, its best water power would be where the highest fall was located. It is estimated that the total power that could be developed by the Mississippi River between St. Louis and New Orleans, where the slope is gentle, is only about 150,000 horsepower. A smaller quantity of water, flowing in the steep portion of the river near its source, could develop 6,430,000 horsepower.



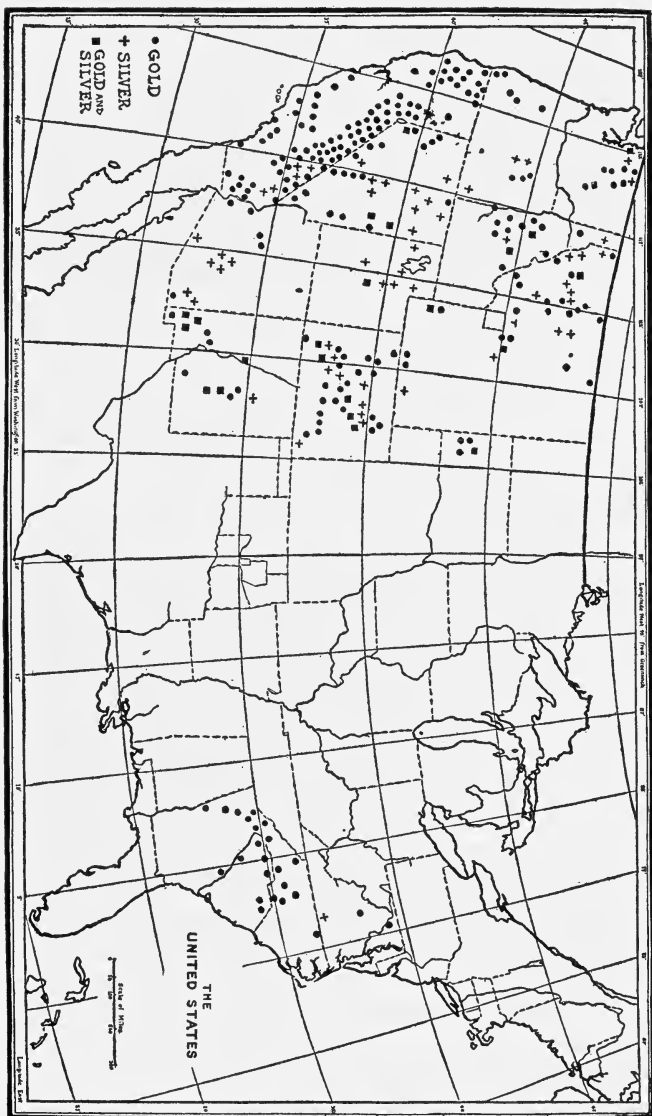

Fig. 162. Distribution of Gold and Silver Mines

After Ransom, U.S.G.S.

Our best water-power opportunities are located in regions of rugged relief, generally at falls or steep rapids. There are numerous falls and rapids on mountain slopes, and the streams often flow in deep canyons that may be converted into great reservoirs for storing water until it is needed. These two advantages have led to an increase in the development of mountain power stations, and it is hoped that the millions of horsepower now being wasted in mountain regions will soon be utilized.

**188. Irrigation.** The high mountains of the United States, like the Sierra Nevadas, the Cascades, and the Rockies, have heavy rainfall on their western slopes, and an arid region east of them, because they lie across the path of the prevailing westerlies.

The mountains are the cause of the arid regions, but they also enable us to restore fertility to the region through irrigation, as artificial watering is called. Through their forests, glaciers, and lakes, mountains are great reservoirs of water which give rivers rising in mountains a much more uniform flow of water than that of rivers rising in plains. Then, too, mountain valleys of such streams can be converted into additional reservoirs of great capacity by building dams across the valleys. From these reservoirs, canals can carry water to each farm in the district.

**★189. Agriculture.** Mountain slopes are not well adapted to agriculture, but there are regions where the number of inhabitants is so great that every foot of land must be made to yield its share of the food supply or someone will go hungry. In China, for example, steep slopes have been terraced by building stone walls, at intervals, on the slopes and by carrying earth up the mountain to fill the space on the upper side of the wall, to produce a nearly level field. This requires labor that doubtless makes the fields thus built much more costly than the same area of level land; but when the work is done, the owner has a field that will furnish food as long as he lives. The Igorots in the Philippines also raise rice on such terraces. In Europe there are many terraced vineyards on mountain slopes (Fig. 163).

Terracing prevents erosion of the soil, which so often destroys slopes as soon as the forests are cleared away. The roots of trees tend to hold the soil in place; and in some places mountain slopes have been slowly converted into orchards of apples, oranges, or olives, by replacing the forest trees with fruit trees. In other sec-

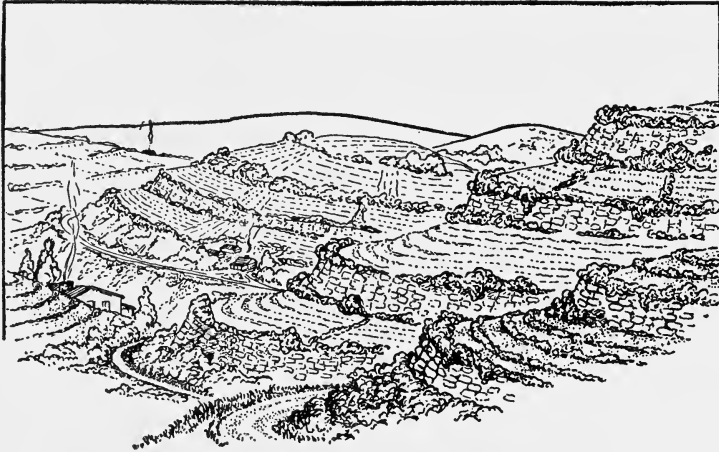

FIG. 163. Farming on Terraces

tions there are groves of nut-bearing trees that yield as great a return per acre as our best wheat land. In all cases of mountainside farming, the cost of raising the crop and of transporting it to market is much greater than it would be if the land were level. The incentive that leads the farmer to incur the extra expense is usually the scarcity of level lands; but occasionally such conditions as the unusual fertility of a certain slope or its favorable exposure to the sun's rays may lead him to cultivate the hillside.

Stock raising is an important industry in the western mountains of both North and South America; also in Switzerland, Germany, and Norway; and in Asia. It is about the only industry that can be carried on at elevations much above a mile; grasses, however, grow nearly up to the snow line, and herds are driven up the mountainside as spring climbs upward, to move down again as autumn climbs downward. The land in the valleys, near the lower limit of the stock-raising belt, are all used to supply hay for winter feeding.

**190. Forest reserves.** The increasing population of the world demands greater and greater supplies of food, leads to the clearing of more and more of the level land each year, and drives the forests to the rugged lands. This increase threatens our supply of lumber and has already used up practically all of the timber that was growing on the plains of Europe. In the United States we still have several large areas of level land, like the pine barrens of the coastal plains, that are forested because of their low fertility, but it is only a matter of time till these will also disappear. As soon as the demand for food has become great enough, these areas will be cleared and fertilized, and then they will be turned to agricultural use.

The United States Forest Service is now developing about 200,000,000 acres of forest land belonging to the government and is employing hundreds of men to patrol the reserves and enforce the rules of the service. It is its policy to prevent loss of trees through forest fires, tree diseases, and wasteful lumbering. It sees that all trees showing signs of deterioration are cut and sold for lumber or firewood, and that every tree that is cut is replaced by a young tree. This plan will eventually permit the sale of six or seven billion board feet of lumber annually without injury to the forests. It builds roads and maintains 1,500 camp grounds that are open to the public.

### *Completion Summary*

A chain of mountains usually includes several ——— ridges.

——— usually has several roughly parallel chains of mountains.

The four great ——— are the North American Cordillera, the Andes, the ———, and the ———.

A single mountain may be either a ———, or a ———.

A ——— cut up by streams becomes a chain of mountains.

Faulting during an uplift ——— mountains.

Most of the great mountain systems owe their origin to ———.

★The great forces engaged in mountain making ——— metamorphosed condition of the cores of the mountains, often exposed by erosion. These rocks ——— metals and their ores.

The ——— mountains show simple folding, while the Appalachians have very complex and faulted ———.

Mountains are often synclinal ——— because ———.

The Appalachians are mature ———.

The Rocky Mountains are not ———, but consist rather of one broad warp, showing vertical ———, rather than ——— pressure. They are ——— mountains.

The life history of mountains corresponds to ——— streams. In youth, ——— grandeur, with ——— forested, and deep ravines. In maturity, the tops ———, waterfalls ———. In old age, ——— with monadnocks.

The climate of mountains is ——— and usually at least one side ———.

Mountains ——— barriers to civilization.

Industries often found in mountainous areas include ———, ———, and ———.

Water power ———, and in connection with water power, irrigation ———. But in spite of all these advantages, agriculture ———.

### *Exercises*

1. How does a mountain or group of mountains differ from a plateau?

2. What is the average slope of mountains? Why do we think it is much steeper?

3. Where do we find the great cordilleras with respect to the oceans?

4. Name the great cordilleras.

5. Name the ranges included in the North American Cordillera.

6. Explain how a volcanic cone is built up.

7. How are dome mountains raised? Name one.

8. Explain why dome mountains are not eroded as fast as volcanic cones.

9. What is a dissected plateau? Name one.

10. How are block mountains formed? Explain.
11. Where are there block mountains in the United States?
12. What are synclinal mountains? Explain how they are formed.
13. What are folded mountains? How do we believe they were formed?
14. Name a range of folded mountains.
15. Why are the Rocky Mountains not badly folded?
16. Choose an appropriate illustration in this chapter and state which of the characteristics of young mountains you find there.
17. Repeat question 16 for mature mountains.
18. Explain the great variation in the climates of a mountain.
19. Select one example to show how mountains prevent the spread of civilization.
20. In a brief outline, show how mountains prevented the spread of colonization in the early history of the United States.
21. Explain how mountains prevented Boston from developing as fast as New York.
22. What are the chief industries of mountains?
23. Why do we discover mines in mountainous areas more readily than elsewhere?
24. Where are the best water-power sites located?
25. Why is irrigation usually necessary on one side of a mountain range?
26. Why is it usually easier to develop irrigation projects near mountains?

#### ★*Optional Exercises*

27. Why is stock raising often followed by mountaineers?
28. Explain the difference between the two types of volcanic cone.
29. In what way does a dome mountain differ from the others? Which type does it most resemble? How could these be distinguished?
30. Describe the cycle of erosion of a plateau.
31. Explain why block mountains have a long, gentle slope on one side, and a short, steep slope on the other.
32. Why are young folded mountains always covered by thick layers of sedimentary rocks?

33. Why are the cores of mountains usually metamorphic? What were they originally?

34. Why do we often find metallic ore bodies in mountainous regions?

35. Show by diagram that the Appalachian Mountains were at one time much higher than they are at present.

36. If there were no erosion, some of our mountains would be fifteen miles high. Explain.

37. Outline briefly the history of the Appalachian Mountains.

38. State features of the topography of New York City which class it as an area of old mountains.

39. State one reason why our water power is not more fully developed.

40. Explain the difficulties of agriculture on mountains. How can some of these difficulties be overcome?

41. Why are the forest reserves confined to mountainous areas?

42. Discuss briefly the work of the Forest Service.

## CHAPTER XVI

# EARTHQUAKES

**191. What is an earthquake?** We often experience a shaking of the earth when a heavy truck rumbles over the pavement. We do not call that an earthquake, but the same intensity of *movement due to natural causes would be called an earthquake*. Our instruments, seismographs, record several thousand earthquakes a year. In 1923 the Tokyo earthquake caused the destruction of 150,000 people and three billion dollars in property. It is estimated that during human history about 15 million people have been killed by earthquakes.

**★192. The Ischian earthquake.** On July 24, 1883, the island of Ischia, near Naples, Italy, was shaken by an earthquake which lasted only 15 seconds. Violent detonations accompanied the tremors, fissures were opened, landslips occurred, 1,200 houses were destroyed, and 2,300 persons were killed. Survivors tell us that the whole town seemed to “jump into the air and fall in ruins.”

On this island is the great crater of Epomeo, a volcano which was in eruption in 1302, after at least 1,000 years of slumber. This earthquake was not accompanied by an eruption but it is believed that the underground explosions which caused the earthquake were of volcanic origin.

**★193. The Charleston earthquake.** In 1886 slight earthquake shocks occurred, at intervals, at Charleston, South Carolina. Their violence gradually increased, culminating in one of the great earthquakes of the century. There was first noticed a distant rumble which increased in intensity as though an enormous railway train were approaching through a tunnel beneath the city. As this rumble became a roar, the ground seemed to rise and fall in visible waves. The disturbance lasted about 70 seconds and was repeated, with the same violence, about 8 minutes later.



During these tremors men could not stand, chimneys were thrown down, and every building in the city was damaged. Great fissures were opened in the earth and both underground and surface drainage were disturbed. Railroad tracks were twisted and bent and 27 persons were killed. The shock was felt as far as Canada.

The earthquake was succeeded by several less severe shocks during the night and slight shocks were observed in the region for several months.

**194. The San Francisco earthquake.** About 5 A.M. on April 18, 1906, an earthquake occurred on the California coast which lasted 67 seconds. During this short interval



*W. C. Mendenhall, U.S.G.S.*

FIG. 164. Building Wrecked in the San Francisco Earthquake of 1906

many buildings in San Francisco were wrecked, gas mains were broken, and the water pipes breached so that the fire which followed destroyed a large part of the city (Fig. 164).

At the same time, landslides occurred in the near-by mountains, fissures were opened in the earth, and some districts settled several feet.

This earthquake was due to slipping along an old fault, the San Andreas Rift, which has been traced 600 miles (Fig. 165). The displacement was entirely horizontal, as is shown in Fig. 166.



*Gilbert, U.S.G.S.*

FIG. 165. The San Andreas Rift

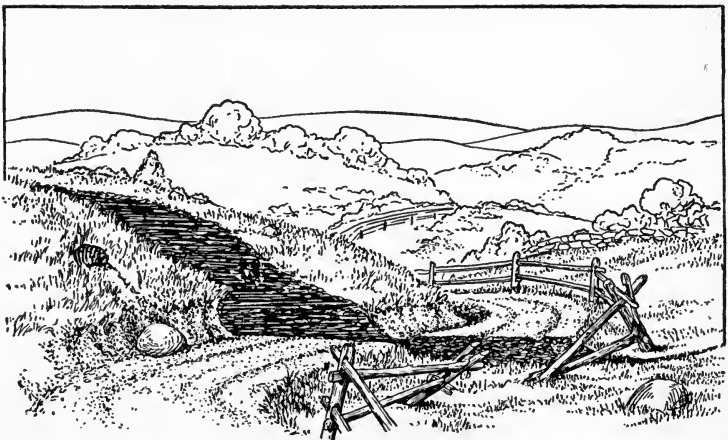

FIG. 166. Displacement of a Road and Fence along the San Andreas Rift

★195. **The Messina earthquake.** At 5:23 A.M., December 18, 1908, the region about the Strait of Messina, in southern Italy, experienced one of the most disastrous earthquakes in the history of the world. The cities of Messina and Reggio were reduced to a shapeless mass of ruins, several smaller towns were more or less damaged, and more than 200,000 persons were instantly killed or imprisoned in the ruins, so that rescue was impossible.

The ground seems to have been suddenly raised and then dropped, causing the buildings to collapse. Great fissures opened. The wharf sank to the level of the sea and a sea wave, from six to ten feet high, swept over the lower portions of the region. The earthquake was preceded by several slight shocks and the seismic activity continued for several weeks. The rupture of telegraph cables indicates a submarine disturbance whose center was a line through the Strait of Messina. It is probable that the earthquake was due to slipping along the old fault plane which runs through the strait. This fault plane has probably been the seat of many earthquakes. The total *vertical* displacement of one side of the fault is known to be several thousand feet.

**196. Distribution of earthquakes.** No portion of the earth is entirely free from earthquakes, although most of them occur either in the vicinity of active volcanoes or near young mountains. The borders of the Pacific Ocean are particularly subject to earthquakes. Another belt crosses Eurasia, beginning at Gibraltar and following the general direction of the Alps, the Caucasus, and the Himalaya Mountains (Fig. 167).

There have been, in recent times, rather few earthquakes among the older mountains which border our eastern coast. Professor Shaler has called attention to the fact that, in New England, there has been no violent earthquake since glacial times; for if there had been one, it would have displaced the numerous balanced rocks, perched boulders (see page 122), which are found there.

It appears from the record, then, that regions of old mountains and wide continental shelves, like those on the Atlantic seaboard, are practically free from earthquakes,

whereas they are very common in regions of young mountains, like those on our western coasts.

Any natural phenomenon which results in a heavy blow to the bedrock might throw a portion of it into a vibration

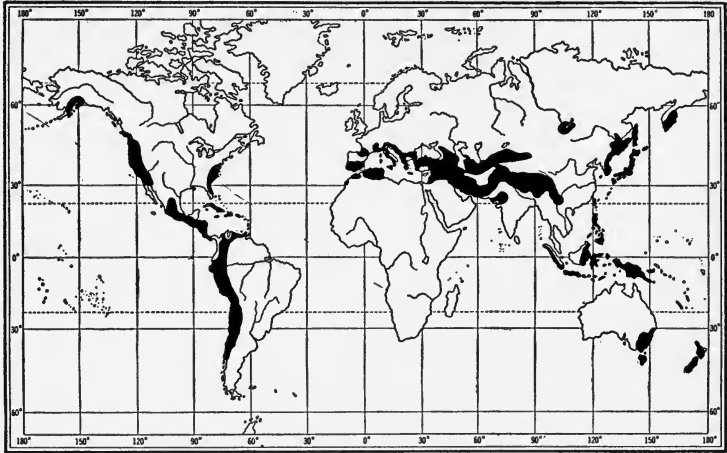

FIG. 167. The earthquake belts are shown in black.

which would be classed as an earthquake. Slight tremors may be caused by great landslides, by the fall of the roof of a large cave, or by similar accidents.

The earthquake belts correspond rather closely to the belts of volcanoes; from which it might be inferred that all earthquakes are caused by volcanoes. But these belts are also the regions in which there are young mountains. We believe that *all major earthquakes are the result of faulting*.

Stresses set up within the crust of the earth by lateral pressure cause deformation of the rocks up to the limit of their elasticity. But when these stresses become too great the rock breaks and slips, making a fault (Fig. 168). After the break the two surfaces are held by friction, and again when this is overcome another slip will occur. The sudden movement jars the rocks, and this sets up an intense vibration.

**197. Seismic sea waves.** When an earthquake occurs in or near the sea, great sea waves are often produced. The water at first recedes from the land, and sometimes leaves vessels stranded on the exposed sea bottom. Then a great wave advances, which has in some instances swept the vessels over the tops of houses and has stranded them far inland. At Lisbon, Portugal, in 1755, some 30,000 people who had sought safety from the earthquake on the wharves were drowned by the sea wave.

These waves have been called tidal waves, but they are obviously not of tidal origin. Most seismologists now call them *tsunamis*, a Japanese word. Some of them are as high as 40 feet, and 200 miles long, and they move with terrific speed — up to about 500 miles per hour.

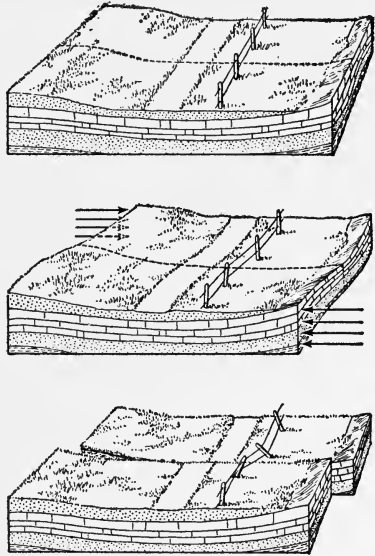

FIG. 168. The upper block, subjected to lateral pressure, as shown in the middle block, may break and slip, as shown in the lowest block. It is the slipping along the fault which causes an earthquake.

★**198. The seismograph** is the instrument used to record earthquake shocks. It operates on the principle of inertia. If one suspends a heavy weight on a spring and then suddenly moves the spring a little, up and down, the weight hardly moves at all, owing to its inertia (Fig. 169).

Now suppose we arrange a framework attached to bedrock, as shown in Fig. 169, and have a suitable drum with a sheet of paper on it — the drum actuated by a clock. If the bedrock shakes, it will move the paper up and down; and the pencil attached to the weight, which remains relatively stationary, will trace the movements of the bedrock on the paper. The time will be recorded by the clock.

Actual seismographs are not so simple as this, but the principle is the same. The record of an earthquake is called a seismogram (Fig. 170).

The primary tremor represents a compressional or sound wave

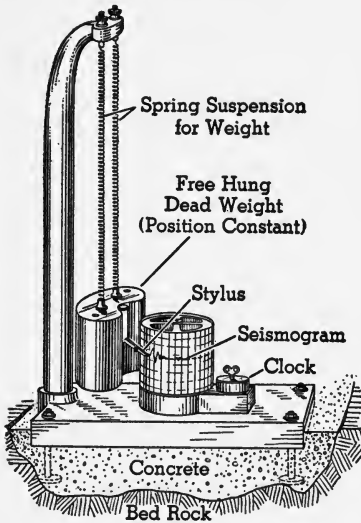

Base Firmly Cemented to Bed Rock

FIG. 169. The Principle of the Seismograph

which travels several miles per second. It is this part of the tremor which makes the rumble, noticed just before the main shock. The secondary travels at about half that speed. The secondary is a transverse wave like a water wave or a wave set up in a long rope. It makes no sound, but shakes the earth. Both are believed to move from the source in the interior directly to the instrument.

The long waves which represent the destructive earthquake waves are transverse. We believe they travel from the seat of the disturbance to the nearest point on the surface, and then through the crust, around the circumference of the earth. Hence they

take longer, but they are more destructive, perhaps because the surface, being free, can vibrate with greater violence.

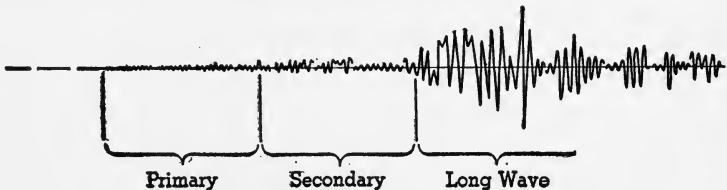

FIG. 170. A Seismogram

**199. Precautions against earthquakes.** For an earthquake whose center is 1,000 miles away the time interval between the primary and the secondary waves will be about two minutes; and in that case, one has a warning of two

minutes before the main shock. This would be sufficient time to run to a place of safety if the primary tremor were recognized.

It has been found by careful study, including accurate surveys of the fault, that it may be possible to predict earthquakes. A careful study of the San Andreas Rift leads one geologist to the conclusion that there will be another major earthquake in California about 1950.

Now, while this prediction may be very inaccurate since it is impossible to collect all the necessary information by surface investigations, it arouses the inhabitants of the region to the necessity of taking all possible precautions against recurrence of an earthquake.

It is found that the destructive effects are much worse on loose material than on solid bedrock. This was noted in the San Francisco earthquake as well as that at Messina. This can be illustrated by placing a small object on a table and giving the table a sharp rap. While the movement of the table is imperceptible, the small loose object will jump into the air.

During the Tokyo earthquake it was noted that buildings with steel frames were not badly damaged, while brick walls, statuary, and other loose objects were toppled down.

Dwellings made of wood stand up much better than those of stone, because of the greater flexibility of wood. However, we must guard against the possibility of fire, which rules out wood, and since the water mains are usually broken, the destruction by fire is often worse than that caused directly by the earthquake.

The loss of life in an earthquake is due usually to the falling of buildings. It is indicated by past events that buildings should be placed on bedrock rather than loose, unconsolidated mantle rock. They should be of steel, with all the trimmings firmly fastened to the framework, so that they cannot fall.

Small buildings in rural districts may be of wood, well

braced, so that they cannot be shaken apart like a house of cards.

### *Completion Summary*

Earthquakes occur in the same regions as volcanoes and young mountains, not because one of these ——— other, but rather because all of them ———.

Major earthquakes ——— faulting. The rocks, under great stress, slip and ———, ——— vibration which is the ——— earthquake.

Earthquake shocks ——— sea ——— tsunamis.

★The seismograph ——— inertia. The ——— sound wave. The secondary ———, while the long waves, which move from the seat of the disturbance to ——— and then travel ———.

The primary tremor may occur ——— minutes before ———. Destruction of buildings built on ——— is much worse than ———. Loss of life is due chiefly to falling ———. Therefore buildings with ——— framework, built on solid rock, with ——— loose ornaments, are safer in earthquake regions.

In country districts, wooden houses ———.

### *Exercises*

1. What is an earthquake?
2. Cite evidence, from the San Francisco earthquake, for our present belief that earthquakes are caused by faulting.
3. What evidence is there that there has been no violent earthquake in New England since the Glacial Period?
4. In what kind of region are earthquakes common?
5. Where are the earthquake belts?
6. What is the cause of major earthquakes?
7. What is a tsunami?
8. What warning does an earthquake give of the main tremor?
9. How does the effect of an earthquake on a structure built on bedrock compare with the effects on a structure erected on loose soil?



10. What precautions should be taken when erecting buildings in regions subject to earthquakes?

11. Where would there be more danger of earthquakes: along a mountainous or along a coastal plain shore?

**★Optional Exercises**

12. Cite evidence of an earthquake caused by volcanic explosions.

13. What characteristics of most earthquakes were shown at the beginning of the Charleston earthquake?

14. Describe the Messina earthquake.

15. Why is it commonly believed that earthquakes are caused by volcanic action? Is there any connection between the two sets of phenomena? Discuss.

16. Explain the relation between earthquakes, volcanoes, and young mountains.

17. How does the seismograph operate? Explain how inertia is used to make the record.

18. What are the primary, the secondary, and the long waves?

## CHAPTER XVII

### VOLCANOES

**200. What is a volcano?** It is commonly thought that a volcano is a burning mountain. A volcano does not begin as a mountain, as is shown by Hobbs in describing the birth of a volcano on the island of Camiguin, north of Mindanao in the Philippines, in 1871. The eruption started with the formation of a fissure in a level plain, continued for four years, and at that time the height of the cone was 1,900 feet. In other words the volcano built its own cone.

There is no burning taking place in a volcano. There is hot material of various kinds expelled, but it is not burning. The cloud that overhangs the crater of Vesuvius is chiefly steam, not smoke, and the glow sometimes seen is a reflection, from the cloud, of the hot lava in the crater.

*A volcano is an opening in the earth through which lava and other heated materials are ejected. This ejection is called an eruption.*

Some of these materials pile up about the opening and form a *cone* which may build up higher and higher until it forms a mountain. In the top of the cone there is a cup-shaped depression called the *crater*.

**201. Phenomena of eruptions.** Eruptions may be classified as *explosive* and *quiet*, although there are some exceptions.

The quiet volcanoes discharge chiefly liquid lava with little gas and no solids. This lava is basaltic in composition; that is, it contains relatively little silica, melts easily, and cools into a very dark rock. The ease with which it melts may explain the absence of explosion.

The explosive type of volcano has highly siliceous lavas

with a high melting point. They usually contain much gas and erupt solid as well as liquid material. All these phenomena can be explained on the basis of the siliceous lava. Since it has a high melting point, it is not so fluid and the gases find it difficult to escape. This causes the pressure to increase until it bursts a way out and hurls lava into the air. With its high melting point, the lava cools at once to a solid while hurtling through the air, and falls to the earth as solid material.

The cone of a quiet volcano is not steep, like the explosive type, because the molten lava continues to flow after the eruption, and tends to seek a level. The cone of the explosive

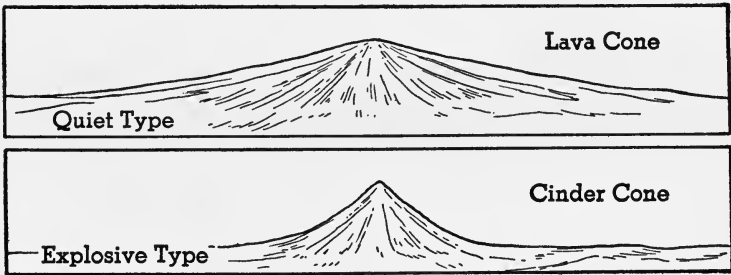

FIG. 171. Two Types of Volcanoes

volcano, on the other hand, is steep, because much of it is built up of solid irregular cinder and ash (Fig. 171).

Mauna Loa, in Hawaii, is quiet, while Fujiyama, in Japan, was explosive (Fig. 172). Vesuvius does not quite belong to either of these types but is more explosive than quiet.

An explosive eruption occurs as follows: A mighty explosion blows off the top of the cone, shattering the lava, and sends steam, mingled with dust and ashes, high into the air, where it spreads out as a peculiar "cauliflower cloud." After that, the eruption may proceed quietly since the crater is now open, permitting lava and gases to flow out. The falling stones and ashes destroy vegetation and may even bury whole cities. The rising steam, cooled by expansion and by mingling with the cold upper air, is con-



FIG. 172. Fujiyama, a Volcano Whose Eruptions Were Explosive

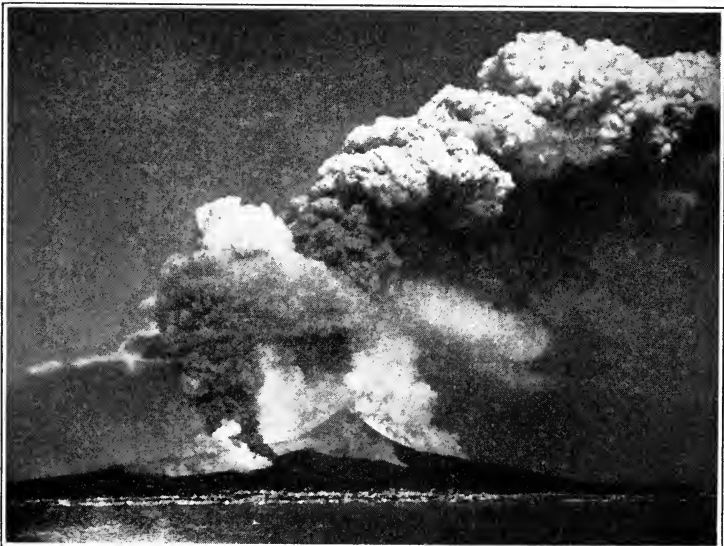

*J. S. Diller, U.S.G.S.*

FIG. 173. Vesuvius, near Naples, Italy

densed and falls as rain accompanied by lightning. The rain brings down volcanic dust and ash, and all together form immense *mud torrents*, capable of burying cities, as, for example, ancient Herculaneum, in Italy.

**202. Products of volcanic eruptions.** It has been estimated that some volcanoes discharge about 5 million gallons of water per day in the form of steam.

Other gases include carbon dioxide, hydrogen, hydrochloric acid, hydrogen sulphide, and sulphur dioxide. Mount Etna must have discharged enormous amounts of sulphurous gases, since we find the porous volcanic rock, scoria, for miles around the volcano, filled with pure sulphur. The sulphur is extracted by the natives and sold.

The lava hurled into the air solidifies before it reaches the earth; but the expanding gas bubbles give it a spongy texture. This is called *pumice*. If the holes are larger, it is called *scoria*. Other volcanic material has various names, depending upon the size of particles: volcanic dust, ashes, lapilli, and bombs.

**203. Economic products.** A British company purchased the cone of Vulcano, a small Mediterranean volcano, because of the alum, boracic acid, and sulphur that could be obtained from it. Pumice and borax are other valuable products.

Traprock, which is volcanic in origin, was used to pave the streets of Rome and the famous Appian Way, while from the Palisades came much of the material to pave the streets of New York City.

Volcanic dust and ash, when consolidated, form *tuff*, a soft stone, easy to work in the quarry, but hardening in air and becoming a very durable building stone, much used in Naples and Rome. Some of the oldest sewers in Rome, built of tuff 2,500 years ago, are still in good condition.

Volcanic dust and ash, exposed to rapid weathering, form a very fertile soil and it is probably for that reason that the farmers on the sides of Vesuvius return to their farms soon

after an eruption, instead of being frightened away permanently.

**204. Distribution of volcanoes.** Active volcanoes are found in the earthquake zones, that is, in the regions of young and growing mountains. There are two such belts. The better-marked belt surrounds the Pacific Ocean. The other belt is an irregular one, passing through the Hawaiian Islands and the Mediterranean Sea, and intersecting the

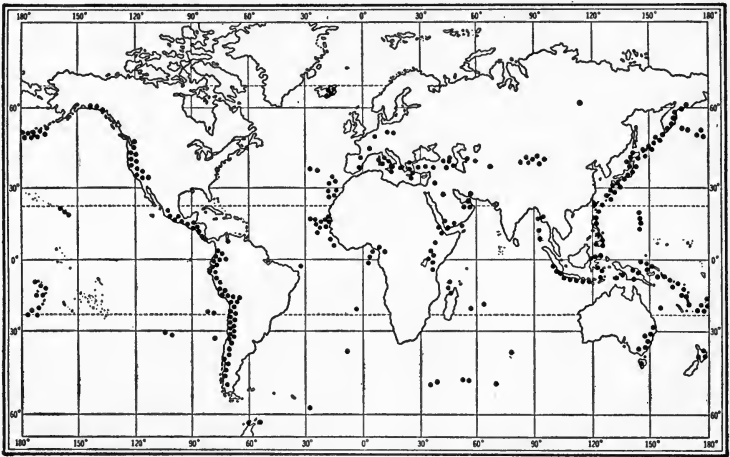

Fig. 174. Distribution of Volcanoes

first belt in the East Indies. Three fifths of all active volcanoes are in the Pacific (Fig. 174).

★**205. Life history of a volcanic cone.** A volcanic cone passes through a cycle of changes, beginning with a period of rapid growth. Cinder cones made of loose material are quickly eroded but cones that consist, at least in part, of lava, resist erosion and it may be a long time before the cone is completely destroyed.

Fujiyama, the famous Japanese volcano, has a perfect cone that shows slight effects of erosion.

The California cinder cone (Fig. 175), although a mass of loose material, shows little effect of erosion. It is a young cone, the result of recent volcanic activity, but there is no record of its eruption.

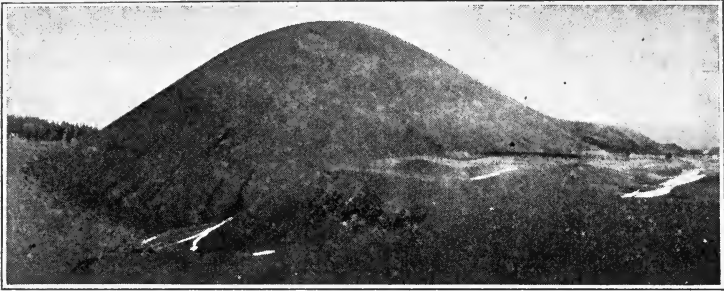

*Photograph by M. E. Dittmar, Redding, California*

FIG. 175. A Young Volcanic Cone



*J. S. Diller, U.S.G.S.*

FIG. 176. Mount Shasta, California, a Volcanic Cone in Late Youth



*G. K. Gilbert, U.S.G.S.*

FIG. 177. San Francisco Mountains of Arizona, a Mature Volcanic Cone

Mount Shasta in California (Fig. 176) is beginning to show the effects of stream and glacial erosion and the San Francisco Mountains of Arizona are in a more advanced stage (Fig. 177). After the cone has been completely eroded the *volcanic neck* usually remains (Fig. 178). Mount Royal, which gives its name to Montreal, is a volcanic neck.

In some of the early periods of the earth's history (page 266) volcanoes were very much more numerous than today. In the Great Lakes Region there are widespread deposits of volcanic ash 15,000 feet thick and there is evidence of thousands of volcanoes in



C. B. Hunt, U.S.G.S.

FIG. 178. A Volcanic Neck

New England alone. These are detected by the remains of volcanic necks still found buried in the sedimentary strata of later periods.

Crater Lake, Oregon (Fig. 108), illustrates another form assumed by some volcanoes in old age. The lake is more than five miles in diameter and the walls rise 2,200 feet above the water. Such large craters are called *calderas*, a Spanish word meaning cauldron. Calderas are formed by an explosion that blows off the entire top of the volcano.

★206. **Etna.** The great cone of Etna was known to the Romans as the "Forge of Vulcan," the god of fire. The word volcano is derived from Vulcan.

Etna is two miles high and 40 miles in diameter at its base. There are some 200 minor cones on its slopes. Its eruptions are preceded by earthquakes and loud explosions. Smoke, ashes, and



cinders are discharged and finally lava flows from the new cone. The large proportion of lava accounts for the gentle slope of the cones.

★207. **Vesuvius.** The ancients knew Vesuvius as a mountain rather than a volcano. At the beginning of the Christian era, its crater, then about three miles in diameter, was covered with vegetation. Its slopes were cultivated, towns were located at its base, and there was no record of previous activity.

During the summer of A.D. 79 a series of earthquakes, of increasing severity, occurred, and a new and strange cloud formed above its summit. Explosion after explosion occurred within the mountain and the black cloud spread, shutting out the light of the sun.

Tacitus gives us two letters from the younger Pliny, who was an eyewitness of this eruption. One of these letters describes the experiences of his uncle, the elder Pliny, who lost his life near the foot of Vesuvius during the eruption. It seems that his party sought shelter from the shower of cinders and stones in a villa which "shook from side to side" from frequent earthquakes. When the accumulation of stones and ash made it apparent that the villa would be buried, the party took to the fields "with pillows tied about their heads" to protect them from falling stones.

The second letter relates the younger Pliny's experiences at Misenum, across the Bay of Naples from Vesuvius. He describes chariots standing on level ground without horses, which "kept running backward and forward" with each earthquake, even though blocked by great stones. "Besides this," he continues, "we saw the sea sucked down and, as it were, driven back again by the earthquake." Across the Bay above Vesuvius "was a dark and dreadful cloud, which was broken by zigzag and rapidly vibrating flashes of fire, and yawning, showed long shapes of flame. These were like lightnings, only of greater extent ———. Soon the cloud began to descend over the earth and cover the sea ——— ashes now fell, yet still in small amount. I looked back. A thick mist was close at our heels, which followed us, spreading over the country like an inundation ———. Hardly had we sat down, when night was upon us — not such a night as when there is no moon, and clouds cover the sky, but such darkness as one finds in close-shut rooms ———. Little by little it grew light again. We did not think

it the light of day, but proof that fire was coming nearer. It was indeed fire, but it stopped afar off; and again a rain of ashes, abundant and heavy; and again we rose and shook them off, else we had been covered, and even crushed by the weight ———. Soon the real daylight appeared; the sun shone out, of a lurid hue, to be sure, as in an eclipse. The whole world which met our frightened eyes was transformed. It was covered with ashes, white as snow.”

Bulwer-Lytton, who lived near Vesuvius for many years, wrote the delightful novel, *The Last Days of Pompeii*, in which he described this eruption of Vesuvius.

No lava flow accompanied this eruption, but the enormous quantity of ash buried Pompeii and, mixed with rain, formed a mud stream which overwhelmed Herculaneum.

Pompeii has since been restored and the ruins furnish us with an excellent idea of the life of the times, since the ash, by covering it, has protected and preserved buildings, streets, paintings, mosaics, tools, and even some of the chemicals used by an apothecary.

There have been frequent eruptions of Vesuvius since that one; those of 1631 and 1906 were especially destructive. In these later eruptions, the explosion has been followed by lava flows.

Unlike Stromboli, which is continuously active but mild, Vesuvius has long periods of rest during which the volcano is said to be *dormant* or sleeping.

★208. **Mount Pelee.** An eruption of this volcano on May 8, 1902, destroyed the city of St. Pierre on the island of Martinique in the West Indies. Previous to this date it had been dormant for 50 years, but for days before the eruption it had shown signs of activity. Great columns of steam and ash were ejected, boiling mud flowed from the sides of the volcano, and repeated explosions occurred in its interior. Lightning flashed from the ascending cloud, and the frequent earthquakes broke all cables leading to the island.

On the morning of May 8 a dull red reflection was seen on the cloud that covered the mountain summit. This became brighter and brighter, and soon red hot stones were ejected from the crater and bowled down the mountain side, giving off glowing sparks. Suddenly a hot blast of gases shot from the crater, and two minutes later engulfed the city of St. Pierre, five miles distant, in an

atmosphere that was fatal to all who breathed it. Thirty thousand persons lost their lives. It wiped out all vegetation and all living creatures in its path. Buildings of the city and ships in the harbor instantly burst into flames.

There was no lava flow, but the neck was forced upward by the pressure from below until it stood 1,200 feet above the crater a

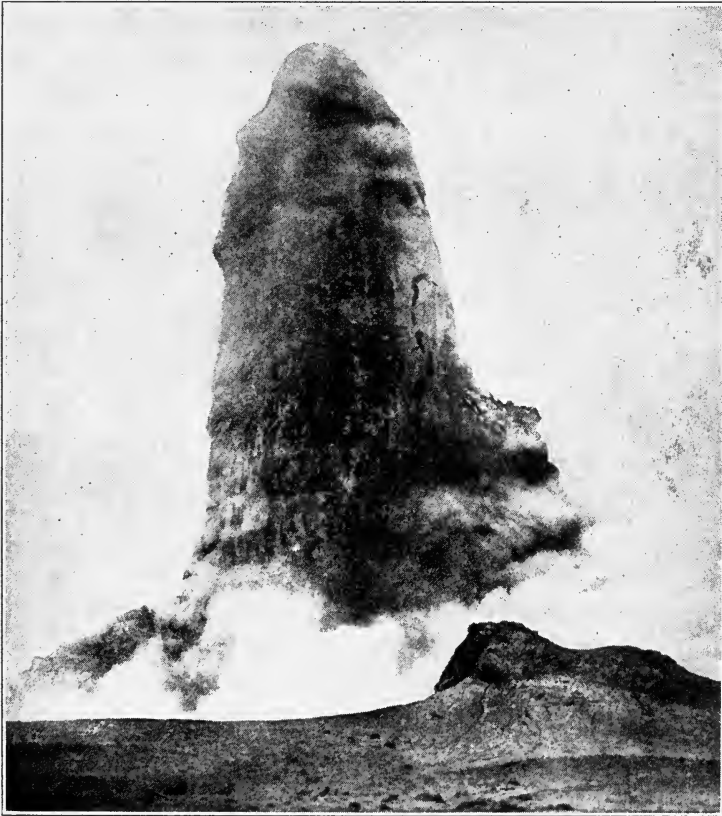

*American Museum of Natural History*

FIG. 179. The Spine of Mount Pelee, a Volcanic Neck

year after the eruption. A series of explosions finally caused this neck to crumble into blocks of stone (Fig. 179).

★209. **Krakatoa.** In 1883 the most violent explosive eruption of history occurred on the island of Krakatoa in the East Indies.

The island was 5 miles long and 3 miles wide, with an altitude of 2,623 feet at its highest point. Nearly the whole of the lower part of the island and half of the peak were blown away. Dust was thrown into the air to a height of about 20 miles and was carried around the earth several times, causing beautiful sunrise and sunset effects for many months. The concussion of the explosion broke windows in Batavia, 100 miles away, and the report of the explosion was heard 2,267 miles away. A mighty seismic wave flooded the surrounding coasts, stranding ocean steamers, causing great loss of property, and drowning more than 36,000 people. For many

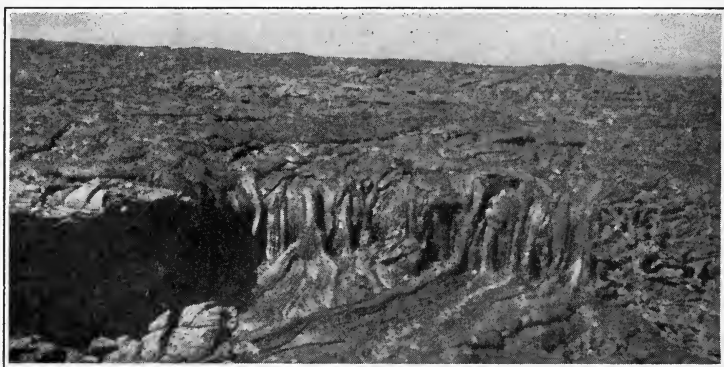

FIG. 180. A Lava Flow

*H. T. Stearns, U.S.G.S.*

weeks navigation was impeded by floating pumice that covered the surface of the sea.

★210. **Hawaiian Islands.** Hawaii is one of a group of islands with many volcanoes which in the main owe their existence to eruptions at the bottom of the ocean. This island is 80 miles long and rises 30,000 feet above the ocean floor. There are four craters on the island, of which Mauna Loa is the highest. The eruptions of the volcanoes in the Hawaiian Islands are in sharp contrast with that of the island of Krakatoa. In these oozing eruptions there are no explosions, no showers of dust or ash; no great volume of steam is ejected, and earthquakes are rare. The lava flows (Fig. 180) sometimes continue for months, whereas eruptions of the explosive type last but a few days. Before an eruption the lava rises quietly in the crater until the great pressure fissures the side

of the mountain, when a river of molten rock flows to the sea. The slopes of the volcano are very gentle, but this must not be understood to mean that the cone is small. Mauna Loa is many times as large as Vesuvius, and its crater is a typical caldera, nearly three miles long, two miles wide, and 1,000 feet deep.

The Icelandic volcanoes are of this type.

**211. Active volcanoes of North America.** Active volcanoes are numerous in Central America and Mexico, and some of the Alaskan volcanoes have recently been in eruption.

*Mount Katmai.* In June, 1912, an eruption of Mount Katmai, in Alaska, occurred, that was remarkable for the large amount of ash ejected. An area 15 miles wide on the south and west sides of the volcano was buried under 50 feet of ash, houses were damaged 100 miles away, the ash was noticeable more than 200 miles away, and total darkness prevailed for more than two days. The sound of the explosions was heard 750 miles down the coast. Fortunately the region around this volcano is sparsely inhabited.

*Lassen Peak.* In May, 1914, the first volcanic eruption in the United States proper to be described by white men occurred at Lassen Peak, California. Lassen Peak is in the Sacramento Valley, about 210 miles northeast of San Francisco.

The eruption began with geyserlike jets or clouds of steam which increased steadily until great bursts of smoke, rising 2,000 feet, formed a "cauliflower cloud." This was followed by pillars of fire visible 100 miles down the Sacramento Valley.

The activity of Lassen Peak has continued intermittently to the present time. Sometimes the material ejected consists chiefly of gases; again cinders and bombs are hurled high in the air; and at other times lava breaks through the sides of the cone and runs quietly down the slope.

The region about the peak is now a national park, containing many other evidences of the recent volcanic activity



Diller, U.S.G.S.

FIG. 181. Lassen Peak, California, an Active Volcano

of the region, such as a lava flow estimated to have been ejected 150 years ago and the large cinder cone 800 feet high, believed to have been formed about the year 1700.

**212. Recently extinct volcanoes of the United States.**

*Mount Hood.* This mountain on the crest of the Cascade Range, in Oregon, is noted for its graceful outlines, and for the fumaroles\* and steaming rifts which still emit sulphurous fumes and indicate comparatively recent activity, although there has been no eruption within the memory of man.

*Mount Rainier.* This stately cone rises from nearly sea level to an altitude of 14,500 feet, and so appears much higher than most of those that reach a greater altitude. It has a bowl-shaped crater, below which, on the sides of the mountain, the rims of former craters may be seen. Jets of steam and gas still issue from small holes or fumaroles in its snow-clad summit, showing that its heat has not entirely disappeared.

*San Francisco Mountain.* This mountain in Arizona is much eroded, and no signs of a crater remain; but it is surrounded by lava flows and beds of cinders, and several hundred cinder cones, formed by volcanic eruptions, are found in the immediate vicinity. Some of these cones were

\* Fumaroles are openings that emit only hot gases.

formed so recently that erosion has not modified the original form of the cone.

*Mount Taylor.* On one of the large mesas or table lands of western New Mexico, Mount Taylor rises to an altitude of 11,000 feet. The mountain is almost entirely composed of lava, and the mesa is covered by a cap of lava. This cone is also much eroded. In the lowland about the mesa are many volcanic necks, each one a mass of lava which cooled in the throat of a volcano that has disappeared.

*Mount Shasta.* This extinct volcano of northern California is in some respects like Etna. It towers 11,000 feet above a base 17 miles in diameter, is snow-clad even in summer, and its eruptions were explosive, followed by great lava flows. There are two great craters; the younger is near the top of one side of the older cone. Some 20 smaller cones are found near the base of the mountain, and from one of these the lava flow may be followed more than 50 miles. The cone is much dissected by glaciers and streams, but it is still in its youth (Fig. 176).

**213. Other indications of volcanic activity.** The Columbia River lava plateau covers a large part of Washington, Oregon, and Idaho with successive layers of lava, which in places reach a total thickness of 5,000 feet. The section of this plateau suggests stratified rock, but the layers represent distinct flows of lava, which are sometimes separated from the next by layers of soil where the roots and trunks of large trees are preserved. This proves that a long interval of time elapsed between the flows. Because of the absence of cones in this region, it is thought that the lava came through fissures. The surface is covered with residual soil of great fertility. This plateau is cut by many deep canyons in which the structure of the plateau is shown.

★In Canada we find two million square miles covered by granitic gneiss. This represents a surface flow of granite, subsequently metamorphosed into gneiss. The earth's crust must have cracked wide open and the lava must have poured out on the

surface. And we have evidence that the earth's crust again and again was broken by the upwelling of enormous masses of molten rock. This was in the early periods of the earth's history, the Archeozoic Era, when we might expect that the crust was still weak. This happened less and less as time went on, but occasionally since then, there have been surface flows through fissures like that of the Columbia River.

**214. Igneous intrusions.** Besides the masses of lava that were evidently poured out on the surface of the land, there are many others that indicate former volcanic activity,

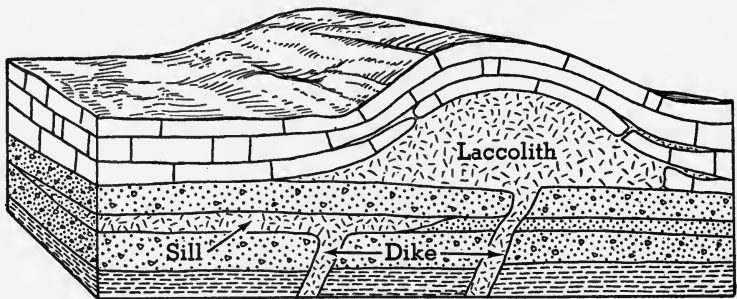

FIG. 182. Igneous Intrusions

although they did not reach the surface of the earth. These are called *igneous intrusions*.

An igneous intrusion that cuts across strata is called a *dike*. Around a volcanic neck there is usually a system of dikes radially arranged. It is by this arrangement that we can recognize an old volcanic neck. An igneous intrusion, parallel to the pre-existing rocks, is called a *sill*. If it bows up the strata (Fig. 182), it is a *laccolith* or lake of rock.

A very large deep-seated igneous intrusion is called a *batholith*. It differs from a laccolith in that the latter rests on a definite floor whereas the batholith has no foundation, extending presumably down into the earth.

The Palisades of the Hudson is a sill, several hundred feet thick and 30 miles long, intruded between layers of sedimentary rocks. The Watchung Mountains of New Jersey are surface flows.



Laccoliths form dome mountains of which the Henry Mountains of Utah are a good example.

There is a great batholith in the Coast Range which is exposed, by erosion of the surface covering, for a length of 1,100 miles and a width of 100 miles. Batholiths, we believe, make the cores of mountain ranges.

★The textures of these igneous rocks show interesting differences. A surface flow is made of very tiny crystals since it cooled rapidly. A dike and a sill will have larger crystals since they cooled between two layers of rock more slowly. If the intrusion is very thick, the crystals near the cooling surfaces will be smaller than those at the center of the intrusion. Batholiths have the largest crystals, because they are the most deep-seated of all intrusions.

**215. Causes of volcanic action.** It used to be thought that the interior of the earth was molten rock, but we now know that it is a solid, although it is very hot — hot enough to be a liquid if the pressure were not so great. The passage of earthquake waves through the interior convinces us that it is more rigid than steel.

The source of the heat is not definitely established. Some believe the earth still has its original heat. But it has been shown that at the present rate of loss the earth would long ago have cooled out.

Some think the contraction of the earth causes the heat; and surely great heat must be generated during movements of the earth's crust, when mountains are being formed.

It is known that granites, in particular, contain radioactive minerals which by their atomic disintegration liberate great amounts of heat; and the granites make up the crust of the earth underlying the continents.

Active volcanoes are in the same region as young growing mountains, and the two are in some way connected with each other and with earthquakes. It may be that the cooling of the earth causes a shrinkage which results in a collapse of the crust. This squeezes the rock underneath and causes it to move. Breaking of the crust causes earthquakes and

squeezing of the interior would cause an eruption wherever liquid was formed.

Kroneis and Crumbein in their very interesting book *Down to Earth* have a very plausible explanation of the cause of volcanic eruptions. The great heat produced by radioactive disintegration, near the surface, may melt the rock locally in spite of the pressure. Hence this liquid rock, exceedingly hot, can now melt some of the rock it passes through, increasing its volume until there is actually a reservoir of liquid. If the liquid reaches the zone of fractured rock at the surface, it will break through in an eruption; if not, we have igneous intrusions.

### *Completion Summary*

A volcano does not \_\_\_\_\_ mountain. It builds \_\_\_\_\_.

There are \_\_\_\_\_ types of volcano, \_\_\_\_\_ and \_\_\_\_\_.

The \_\_\_\_\_ type has a \_\_\_\_\_ cone, due to \_\_\_\_\_.

★An explosive eruption is caused by \_\_\_\_\_.

Volcanoes discharge much \_\_\_\_\_, \_\_\_\_\_, and \_\_\_\_\_; and the \_\_\_\_\_ is often of considerable value.

There are \_\_\_\_\_ volcanic belts: the chief one \_\_\_\_\_, while the other \_\_\_\_\_.

★In the early periods of the earth's history, volcanoes \_\_\_\_\_.

\_\_\_\_\_ is an explosive volcano, as is proved by its \_\_\_\_\_ cone, while \_\_\_\_\_ is quiet. \_\_\_\_\_ is an active volcano in the United States \_\_\_\_\_ and \_\_\_\_\_ are recently extinct.

The Columbia River Plateau was formed by \_\_\_\_\_.

★A great area of Canada is covered by granite gneiss. This is believed to \_\_\_\_\_.

Igneous intrusions \_\_\_\_\_ volcanic \_\_\_\_\_ surface. A dike \_\_\_\_\_; a sill \_\_\_\_\_; a laccolith \_\_\_\_\_; a batholith \_\_\_\_\_.

★The texture of igneous rocks depends \_\_\_\_\_. Fine-grained \_\_\_\_\_, while coarse-grained rocks \_\_\_\_\_. Most batholiths, therefore, \_\_\_\_\_ grained rocks.

The earth's interior is ——— molten, but it is very hot. There are several theories to explain the ——— heat. The collapse of the crust due to ——— may be the cause ———. The disintegration of radioactive material ———.

### *Exercises*

1. Criticize the statement, "A volcano is a burning mountain, belching forth fire, smoke, and lava."
2. Why does a volcano sometimes seem to be burning?
3. What two kinds of volcanoes are there?
4. Explain why one has a steep cone while the other has not.
5. Why is one type of volcano explosive?
6. Name a quiet volcano.
7. Name an explosive volcano.
8. Describe an explosive eruption.
9. Name three gases expelled during volcanic eruptions.
10. How do we know that Mt. Etna has discharged enormous quantities of sulphurous gases?
11. Account for the spongy texture of pumice and scoria.
12. Name three valuable substances obtained from volcanoes.
13. Why do people locate farms on the sides of volcanoes?
14. Locate the two belts of volcanoes.
15. Where are most of the active volcanoes?
16. Name a young volcano.
17. Why are volcanic cones easily eroded?
18. What part of the volcano usually remains after erosion of the cone?
19. What type of volcano is Etna?
20. What is a dormant volcano? Mention one.
21. Mention two active volcanoes in North America.
22. Name an active volcano in the United States. Where is it?
23. Name three recently extinct volcanoes in the United States. Where are they?
24. Why does the Columbia River Plateau seem to be built of sedimentary rocks?
25. In what stage of the cycle of erosion is the Columbia River Plateau? What is the evidence?
26. What is a dike? sill? laccolith? batholith?

27. What is thought to be the cause of volcanic activity? Give one explanation.

28. How can people near a volcano tell that an eruption is probably about to take place?

**★Optional Exercises**

29. Using the theory of isostasy, explain the location of the two belts of volcanoes.

30. At what time in geological history were volcanoes very numerous? Discuss, showing that it is in agreement with the theories of the earth's origin.

31. Since the volcanoes of past geological periods are completely extinct, how do we know of their existence?

32. What is a caldera? Name one.

33. In what way has the burial of Pompeii helped us to understand the life of the ancient Romans?

34. Describe the eruption of Krakatoa.

35. Describe an eruption of Mauna Loa.

36. Cite evidence of volcanic activity in the early history of the earth, showing that it has gradually diminished in severity.

37. Explain the relation between the texture of igneous rocks and rate of cooling, mentioning each kind of igneous intrusion.

38. Explain the theory of volcanism cited from *Down to Earth*.

## CHAPTER XVIII

### STORIES IN STONES\*

#### EARTH HISTORY AS RECORDED IN THE ROCKS

★216. What took place on this earth in the very beginning we have no way of telling, because the igneous rocks, which were formed when the surface cooled, have left no records which we can decipher. We have theories of the earth's origin and of the changes that carried it through a gaseous and then a liquid condition, but not a shred of direct evidence.

★217. **Fossils.** Our history begins with the falling of rain, because at that time the process of erosion started, sediments were carried down to the seas, and some of the remains of plants and animals were buried and thereby preserved. We call such specimens *fossils* (Latin *fossilis*, an object dug up). Casts or moulds of shells, footprints, or anything that indicates the former existence of organisms, we call fossils.

We believe life started in the water, but if there was any on the land, we should not expect to find the traces, because that early life was soft-bodied and there was no way it could have been preserved on land, exposed to the destructive action of the weather.

We believe life started in the shallow marine waters on the continental shelf, where we find it in profusion today; not too near the shore, where wave action keeps churning up the bottom, but in the quiet, warm waters whose depth is less than 100 fathoms. Here the marine plants grow undisturbed, since sufficient sunlight penetrates the water to that depth. Animals, feeding on the plants, lived and died in the same zone. The sediments brought down by the streams (sand, silt, and mud) were deposited on the continental shelf rather near the shore, and gradually covered the remains of the organisms which strewed the bottom. If this burial occurred soon enough, the remains were protected from further destructive action and thereby preserved.

\* This entire chapter is optional.

Farther out from shore, where sediments do not reach and the water is clear, we find abundant vegetation, since more sunlight can penetrate the clear water. Here we find very many animals, too. The bottom becomes covered with the remains of these plants and animals and with the powdery calcium carbonate precipitated by calcareous algae, which buries the entire mass.

In process of time, as we have seen, these sediments (sand, mud, and calcium carbonate) are converted into sandstone, shale, and limestone, which contain the fossilized remains of organisms that existed there in the shallow marine waters.

At first, the deposits laid down in the waters near the shore are very coarse, since the streams flowing down from the high places have considerable velocity. As the highlands are worn down, the stream velocity decreases and the sediments are finer, until, at peneplanation, there are no streams and the waters become clear. Hence we can tell by an examination of the sedimentary rocks of a past age just where the highlands were at that time, since the coarsest sediments, the conglomerates, must have been deposited right at their bases. On top of the conglomerates we shall expect to find sandstones, then shales, formed from mud, and finally limestone covering all, since the highlands were by that time all planed down and the waters were clear.

★218. **How we measure geologic time.** As the highlands are eroded and the sediments piled along the continental shelf, the pressure on the underlying crust of the earth causes an isostatic adjustment, which slowly pushes up the continent once more; erosion begins again with subsequent deposition of conglomerate, sandstone, shale, and limestone. We divide geologic history into periods, each of which starts with an uplift and ends with peneplanation; or, as we read it in the rocks, a period starts normally with a conglomerate and ends with a limestone.

Our history tells us only what happened on the continental shelf and only by inference do we get any history of the continents; for example, when a shale is followed by a conglomerate instead of a limestone, we must infer that the near-by land was rather suddenly elevated.

Each time when the sediments of a period are uplifted and eroded, we have an *erosion interval* during which no history is written since no sediments are deposited. In other words we have

gaps in the story. We can identify the erosion interval in the rocks by the *unconformity* between two sediments. Sediments are laid down smoothly and horizontally but when they are uplifted and erosion sets in they become irregular, and this irregular line between two layers we call an unconformity (Fig. 183).

To figure, in years, just how long ago any geologic event took place, we have several methods. The accuracy of one of these criteria is beyond dispute. Deposits of clay, laid down in a lake, frequently show alternating layers of fine and coarse material; the coarser layer was brought in during the spring flow, while the finer clays settled during the winter, when the waters were quiet.

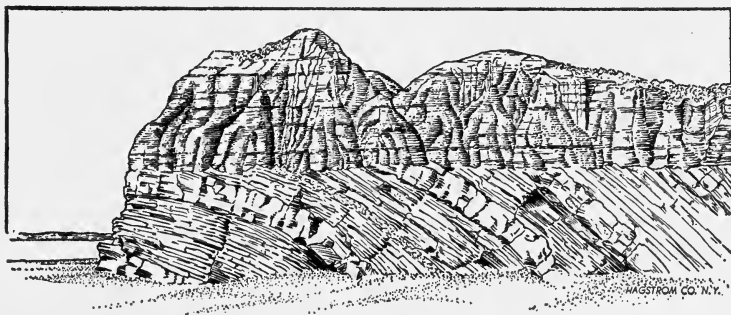

FIG. 183. An Unconformity

Apparently, the tilted and folded strata below were first eroded to a plain and then submerged. The upper, horizontal strata were deposited and finally the entire district was uplifted and eroded as we find it today.

Evidently two *varves*, as they are called, represent one year. We know, for example, that the last glacial period ended 25,000 years ago, because there are varved clays containing 25,000 double layers from the southern limit of the glacier to its present position (Fig. 80); hence it took 25,000 years for the glacier to retreat from New England to its present position.

Another criterion for measuring geologic time is the rate of denudation and deposition of sedimentary rocks. By measuring the deposits brought down by streams, we find a rate of about one foot in 5,000 to 10,000 years over the land. On that basis 50,000 feet of sediment required, roughly, 500 million years to deposit. But this method is subject to much uncertainty.

The latest method of determining the lapse of time depends upon

the radioactive disintegration of uranium and thorium minerals. Chemists have found that the time taken for this change is fixed and unalterable, being unaffected by heat, pressure, or any other force. Hence we may use it as a clock.

On this basis the oldest rocks so far tested are 1,850,000,000 years old, and it seems probable that the earth is at least two billion years old.

★219. **How we read the pages of geologic history.** It is apparent, from what we have just seen, that nearly all the evidence we have of the events of the past is to be found in sedimentary rocks. The

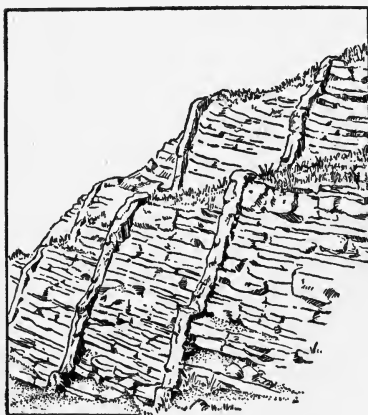

FIG. 184. Igneous Intrusions,  
Almost Vertical

They are younger than the strata they cut across.

a convulsion of nature, changing, as it must have changed, the entire environment, brought about great changes in the life of the time. Hence the fossils of two succeeding periods will show marked differences.

Within each period, changes in the elevation of the near-by lands are marked by the texture of the rock; fine-grained rocks show low elevation and coarse-grained indicate high elevation. At the same time the organisms are changing and samples of many of these will be left in the sediments. Each page of the history, represented by a single layer of rock or a closely related group of layers following one another without unconformity, is called a *formation*.

succession of events will be seen in the relative position of the strata, the youngest lying on top unless there has been a disturbance that has caused the normal succession to be overturned. The age of an igneous intrusion must be related to the sedimentary rocks which it pierces. It is evident that an intrusion must be younger than rocks it cuts across (Fig. 184).

Each period is separated from the rest by an unconformity which marks a gap or erosion interval, caused by an upheaval which re-elevated the land and subjected it to weathering. Such



Each formation is distinguished by the presence of the same or closely related fossils.

The nature of the fossils in a formation is often an index of the climate. For example, we know that coral lives in warm, shallow, marine waters; and we must assume that the corals of the past did likewise. Therefore, if a coral formation is found in the Arctic regions, we infer that the climate there was warm at that time. The chapters of geologic history already worked out are represented by the geologic table which is shown on pages 262 to 265.

It will be noticed that the great divisions or eras of geologic history are separated by revolutions. These are widespread crustal movements which so changed conditions on earth that the life before and after was markedly different.

Each era is divided into *periods*, during each of which the sea inundated the land, and at the end of each period the land again emerged through an uplift, which was not so extensive or long continued as a revolution.

During each period the streams deposited on the submerged land a series of sedimentary rocks. Each stratum is called a *formation* when it contains the same or closely related fossils.

If we compare the rocks to a book, then the eras are chapters, the periods are paragraphs, and the formations are sentences.

★220. **The Archeozoic Era.** The earliest period in which we find any evidence of life at all we call the Archeozoic Era (which means the time of very ancient life). It is represented by a few layers of sedimentary rocks, but most of the rocks of the period are highly metamorphosed and of igneous origin. This agrees with our expectations, since we believe that life started as one-celled plants and animals without any hard parts like shells. Soft-bodied creatures would hardly be preserved as fossils after such an enormous lapse of time.

However, we do find great deposits of graphite in Archeozoic rocks. Now graphite is carbon, formed from coal or other plant material by metamorphosis. There is said to be more carbon in the Archeozoic rocks than in those of the Pennsylvanian, which are our present source of coal. This would seem to indicate the existence, in the Archeozoic Era, of considerable plant life.

It is claimed that fossil algae and even sponges have been found

## GEOLOGIC HISTORY OF NORTH AMERICA

Era	Period	Crustal Movements	Development of Plants and Animals	Rocks
<b>CASCADIAN REVOLUTION.</b> Mountains of the west elevated again, beginning in the Miocene and continuing to the present time.				
<b>CENOZOIC ERA</b> Age of Mammals and Modern Seed Plants				
Recent (25000 yr.)	Elevation of marginal lands (coastal plains) Uplift continues in the west.	Man dominates the scene. <i>Civilization begins.</i>	Loose deposits only	
Pleistocene (2 million yr.)	<i>Glacial periods alternating with warmer intervals</i> Grand Canyon being cut by rejuvenated Colorado River	<i>Man appears in interglacial periods and develops from manlike ape to apelike man, to Heidelberg man, to Neanderthal man, to Cro-Magnon, to modern man.</i>	Loose deposits of glacial origin	
Pliocene (10 million yr.)	Elevation of the continent continues, particularly in the west. (Himalayas uplifted) Erosion in <i>Grand Canyon</i> begins. Climate cool	Appearance of <i>manlike ape</i> in Africa In England, <i>coliths</i> (flints) made by man Primitive cats and dogs	Marls and continental deposits: sands, gravels, etc.	
Miocene (15 million yr.)	<i>Crustal disturbance</i> in the west with extensive surface flows (igneous) Climate cool	Horses and elephants show development. (Tailless apes in Europe and Asia) <i>Birds and trees modern</i>	Sediments of all kinds including phosphate deposits	
Oligocene (10 million yr.)	Marginal seas only Equable climate A time of erosion	Elephants appear. <i>Mammals dominate</i> the lands and seas. Primates have disappeared in N. America.	Consolidated and unconsolidated sediments	
Eocene (20 million yr.)	Only about 6% of continent covered and only on margins Climate mild	Rise of <i>modern mammals</i> , and <i>birds</i> First primates appear. Dominance of modern flowering plants (seed-bearing)	All kinds of sediments, many of them unconsolidated	

LARAMIDE REVOLUTION. Rocky Mts. formed. Great igneous activity from Mexico to Alaska. Appalachians elevated again.

MESOZOIC ERA		Age of Reptiles and Medieval Seed Floras	
Cretaceous (60 million yr.)	Widespread submergence of the continent for the last time	<i>Extinction of dinosaurs at end of period</i> <i>Birds and mammals begin.</i> <i>Modern flowering plants</i> appear with great increase of modern insects.	All kinds of sediments, but very often they are unconsolidated. Chalk present
Jurassic (30 million yr.)	Nevadan Revolution at end of period, forming <i>Sierra Nevada, Coast Range, and other mountains</i> Appalachians peneplaned Pacific waters encroached on land. Climate arid	Giant reptiles ( <i>dinosaurs</i> ) Toothed birds <i>Primitive mammals</i> Modern insects appear. Cycads and conifers dominant Conifers become modern.	Sandstone, shale, and limestone with gypsum
Triassic (30 million yr.)	<i>Palisade disturbance</i> ends period, accompanied by volcanic activity. Continent emergent Submerged only on margins Arid climate	Dominance of reptiles First mammals Cycads and conifers the most common plants	Sediments, but no limestones Igneous intrusions and surface flows

The events of geologic history outlined in this table correspond to the rocks as we find them. The rocks on top give us the history of most recent times. To read geologic history, like human history, beginning with the earliest times, this table must be read from the bottom up, starting on page 265.

**PALAEZOIC ERA**  
Age of Invertebrates and Marine Floras

Era	Period	Crustal Movements	Devel't of Plants and Animals	Rocks
<b>APPALACHIAN REVOLUTION.</b> Uplift of Appalachian region. Pronounced mountain-making epoch, the world over.				
<b>Permian</b> (40 million yr.)	Continent emergent Climate cold Widespread aridity	<i>Extinction of trilobites and many other invertebrates</i> Development of reptiles Disappearance of many old types of plants. Rise of seed floras	Sediments, including much salt	
<b>Pennsylvanian</b> (40 million yr.)	Repeated rise and fall of land Warm and moist climate Much swampland, resulting in <i>great coal deposits</i>	Great forests of scale trees and ferns (spore-bearing) <i>First reptiles</i> <i>Insects numerous</i> and large	Chiefly shales with much coal	
<b>Mississippian</b> (30 million yr.)	Toward end of period, mountains raised in S.E. Canada and southern Appalachians During most of period, land submerged and warm	Crimoids numerous Fishes well developed Amphibians numerous <i>Forests of ferns and conifers</i>	Sandstones, shales, and many limestones	
<b>Devonian</b> (40 million yr.)	<i>Acadian disturbance</i> ends period. Mountains raised in N. Hampshire, Vermont, Maine, and near-by Canada. Volcanic activity	Marine fishes numerous First amphibians Brachiopods prominent <i>First forest</i> (tree ferns)	Chiefly limestones; but other sediments found	
<b>Silurian</b> (30 million yr.)	Widespread submergence in the central continent No mountain making, but local volcanic activity	<i>First land animals</i> (scorpions) appear. Abundance of reef corals <i>First land plants</i>	Conglomerates, sandstones, and shales with many limestones	
<b>Ordovician</b> (60 million yr.)	Taconic and Green Mts. raised at end of period 60% of continent submerged	Invertebrates still dominant, but <i>first vertebrates appear</i> . Beginning of corals and fresh-water fishes	Widespread limestones Slate in Vermont	
<b>Cambrian</b> (100 million yr.)	30% of N. America submerged Climate mild	Fossils very numerous <i>All kinds of marine animals except vertebrates appear</i> . Trilobites dominant	Chiefly sedimentary, some metamorphosed, very little igneous	

<p><b>KILLARNEY-GRAND CANYON REVOLUTION.</b> A long period of uplift in Arizona and in the Lake Superior region. This was followed by the Lupalian Interval, an emergence of the continent of sufficient duration to wear down the mountains to peneplains.</p>	<p>Metamorphic rocks of sedimentary origin</p>
<p><b>PROTEROZOIC ERA</b> 500 million years</p> <p><i>Much volcanic activity</i> Greatest deposits of metallic ores in history. These include the iron, copper, silver, gold, and nickel deposits of U. S. and Canada. Simple marine life: algae and sponges Very few fossils Evidence of a glacial period</p>	
<p><b>LAURENTIAN-ALGOMAN REVOLUTION.</b> Long period of uplift and erosion. Great mountains raised in Canada, the Great Lakes region, and Adirondacks. These mountains were all eroded to peneplains before the opening of the Proterozoic.</p>	<p>Highly metamorphosed rocks of igneous origin Some sedimentary</p>
<p><b>ARCHEOZOIC ERA</b> 500 million years</p> <p><i>Widespread volcanic activity.</i> Great mountain ranges formed Simple plants and animals (one-celled) No actual fossils. Evidence lost by metamorphism</p>	
<p><b>AZOIC ERA</b> (Time unknown)</p> <p><i>Formation of the earth</i> Cooling and hardening of the crust No life</p>	<p>No sedimentary rocks</p>

The events of geologic history outlined in this table correspond to the rocks as we find them. The rocks on top give us the history of most recent times. To read geologic history, like human history, beginning with the earliest times, this table must be read from the bottom up, starting on this page.

in rocks of this era, but these claims are not accepted by most geologists.

What sort of picture, then, can we draw of this Archeozoic Era, which endured for about 500 million years? In Canada we find two million square miles covered by gneiss. This apparently represents a surface flow of igneous rock, subsequently metamorphosed into gneiss. The earth's crust must have cracked wide open and the molten magma of the interior must have been poured out on the surface. We have evidence that the crust again and again was broken by the upwelling of enormous masses of molten rock.

Then came long periods of quiet during which the forces of erosion were at play, laying down great thicknesses of sediment. These sediments are folded, crushed, and injected with igneous intrusions, all of which speak of violent disturbances, terrific earthquakes, far surpassing anything man has ever experienced — mountain formation on a grand scale.

And when such a period of upheaval was over, quiet again reigned over all the earth, quiet unbroken by cry or screech. For there were no birds, no insects, no trees or bushes, only bare rocks, granites. The scene was quite desolate — only here and there a little mass of algae clinging to the rocks in the warm waters (Fig. 185).

The close of the Archeozoic Era was in keeping with the rest. It was ended by the Laurentian-Algoman Revolution, a period of uplift, during which great mountains were raised in Canada, the Great Lakes region, and the Adirondacks. This was followed by a long period of rest, during which these high mountains were eroded down to peneplains.

★221. **The Proterozoic Era.** The second great division of history is called the Proterozoic Era, or time of "earlier life," referring to the fact that geologists at first failed to find any fossils in these rocks, older than the Cambrian. Both the Archeozoic and Proterozoic are classed together as pre-Cambrian.

At the opening of the Proterozoic we find the continent of North America marked out as a very definite land mass, considerably larger than it is today. Greenland was joined to Scandinavia, and the West Indies were attached to Florida and Yucatan (Fig. 186).

Volcanoes must have been very numerous and very active during this time, for we find widespread deposits of volcanic ash, in



Fig. 185. The Archeozoic Era

places 15,000 feet thick, but the earth's crust seems to have become firmer, for we do not find it cracking wide open as often as it did in the Archeozoic.

The great igneous intrusions of this era brought up with them the richest ore deposits ever produced in history. These include the iron and copper ores of the Lake Superior region, and the cobalt, nickel, silver, and gold ores of Canada.

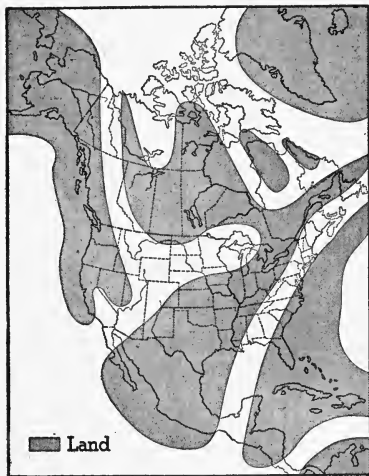

FIG. 186. North America in the Proterozoic Era. (After Schuchert)

The black outline shows the present continent.

There was much more life than that, however, is evidenced by the great thicknesses of black slate, saturated with carbon formed from marine organisms.

The original atmosphere contained possibly as high as 40% of carbon dioxide; but, by this time, much of it had been absorbed by the plants which retained the carbon and set free the oxygen. We find, here and there, strata of red deposits which we know are formed by oxidation of iron compounds; these show that the air already contained considerable oxygen.

The Proterozoic Era closes with the elevation of high mountains in the Great Lakes region (Killarney Mountains) as well as in Arizona (Grand Canyon); hence this period is called the Killarney-Grand Canyon Revolution.

Then follows a period of erosion which we believe was very long,

The climate was mild during most of the time, but now and then it became cold enough to allow glaciers to move over the land, since we find glacial till including faceted boulders.

The life was still confined to the seas — simple, soft-bodied creatures, for the most part algae, sponges, and worms. But among them we find siliceous sponges and radiolaria, which have learned to extract silica from the waters and to build hard structures to protect or support their bodies. That there



because during this time the marine life developed so considerably that by the opening of the next period, the Cambrian, we find every class of animals except vertebrates. Nowhere have we found any direct fossil evidence of this development; hence it has been called the Lipalian (lost) Interval. The Proterozoic Era, including the Lipalian, lasted about 500 million years.

★222. **The Paleozoic Era.** The curtain now rises on a new scene. Instead of the very simple, soft-bodied creatures of the Archeozoic and Proterozoic, the seas are teeming with life: thousands of species of marine invertebrates (many of them in existence today) and hordes of each species jostle each other in their struggle for existence.

It was at first thought that these fossils represented the oldest life of the earth and it was consequently called *paleozoic*, which means "ancient life." The first period of the Paleozoic Era is called the **Cambrian**.

During the Cambrian, much of the continent was submerged and the land was low and uninteresting. The climate was mild, even warm, but no plants clung to the bare rocks and no animals were to be seen on the land (Fig. 187).



FIG. 187. North America in the Cambrian Period. (After Schuchert)

One of the characteristic animals of the Cambrian, now extinct, was the trilobite. Trilobites were numerous and variegated. They had an external bony covering like that of the lobster and horseshoe crab. Some of the early ones seem to have been blind; others had many eyes that could not be moved, but they had many sets of eyes, one for each direction. One species was able to look in ninety-eight different directions at the same time. A few of the Cambrian animals are shown in Fig. 188.

In the **Ordovician** period, following the Cambrian, the greatest inundation of history occurred, flooding about 60% of the conti-

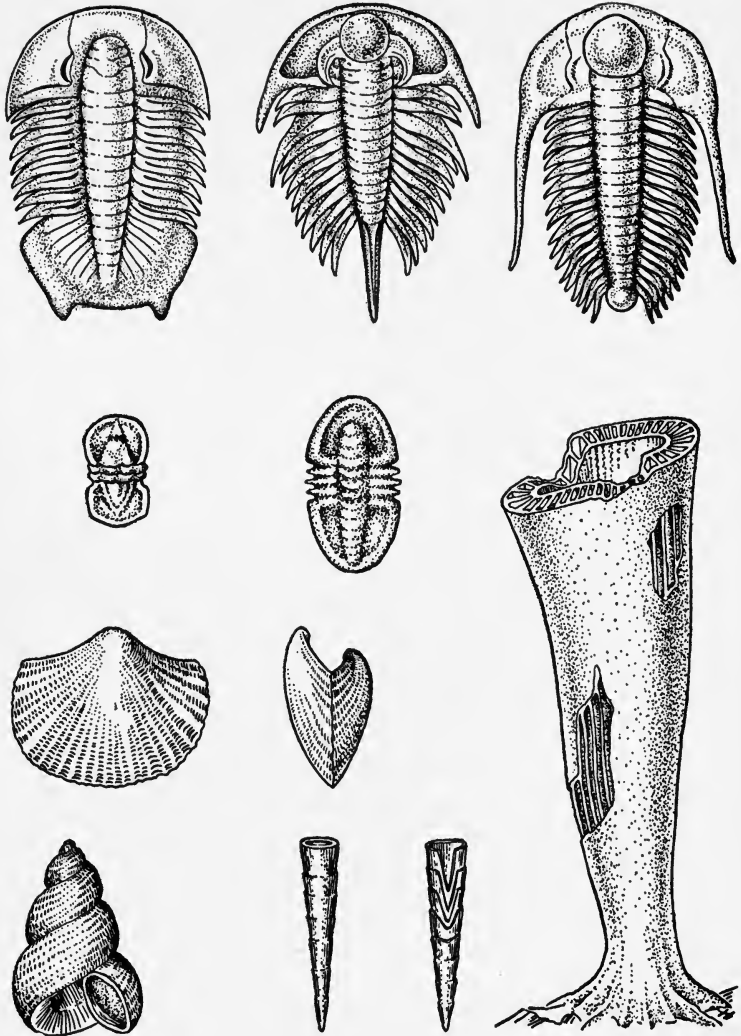

FIG. 188. Cambrian Fossils  
The upper ones are trilobites.

nent. Most of the rocks of this period are limestones, which are laid down in shallow marine waters; and this is evidence of the lowness of the land, for if there were highlands near by, the streams must have carried sand and mud into the seas to form, ultimately, sand-

stones and shales. In this period invertebrates are still dominant, but fresh-water fishes make their appearance. These are the first vertebrates. Trilobites are still numerous but their enemy, the cephalopod, an active, predaceous creature, has begun to develop rapidly (Fig. 189).

The Ordovician was brought to a close by an upheaval which left the Taconic and Green Mountains of New England; and it was followed by the **Silurian**, a period of widespread submergence in the central part of the continent. Now the first land plants make their appearance and the first air-breathing animals, the scorpions (Fig. 190).

Corals, which first came in the Ordovician, have developed so that they form extensive reefs across entire states.

The **Devonian** period presents again a new scene. The land is clothed with vegetation, forests of tree-ferns, and several species of animals are to be seen (Fig. 191). In the sea there is a great increase in the number and variety of fishes (Fig. 192).

“These, the first strong-jawed tyrants of the sea, came all at once, like the rush of the old Norman pirates into the peaceful seas of Great Britain. They made a lively time among the sluggish beings of that olden sea. Creatures that were able to meet feebler enemies were swept away or compelled to undergo great changes, and all the life of the oceans seems to have had a spur given it by these quicker-formed and quicker-willed animals.”

The Acadian disturbance, which raised mountains in New England and near-by Canada, ended the Devonian period.

During most of the two following periods, the **Mississippian** and **Pennsylvanian**, sometimes called the Carboniferous or Age of Coal, the land was low-lying, warm, and moist. There was great abundance of land plants, great swampy forests of scale-trees and ferns. Insects were numerous and large. Eight hundred kinds of cockroaches (some of them four inches long) have been found in the rocks of this age; the Pennsylvanian is sometimes called the Age of Cockroaches. The largest known dragonfly, twenty-nine inches across the wings, is found in these strata.

Amphibians were numerous, some of them as large as alligators; and, in the Pennsylvanian, the first reptiles roamed the forests. We are particularly interested in these because they were the first land vertebrates.



Fig. 189. An Ordovician Scene. Cephalopods are stranded on the beach.



FIG. 190. The Silurian Period. Ancestors of the scorpions are trying to crawl up on the land.

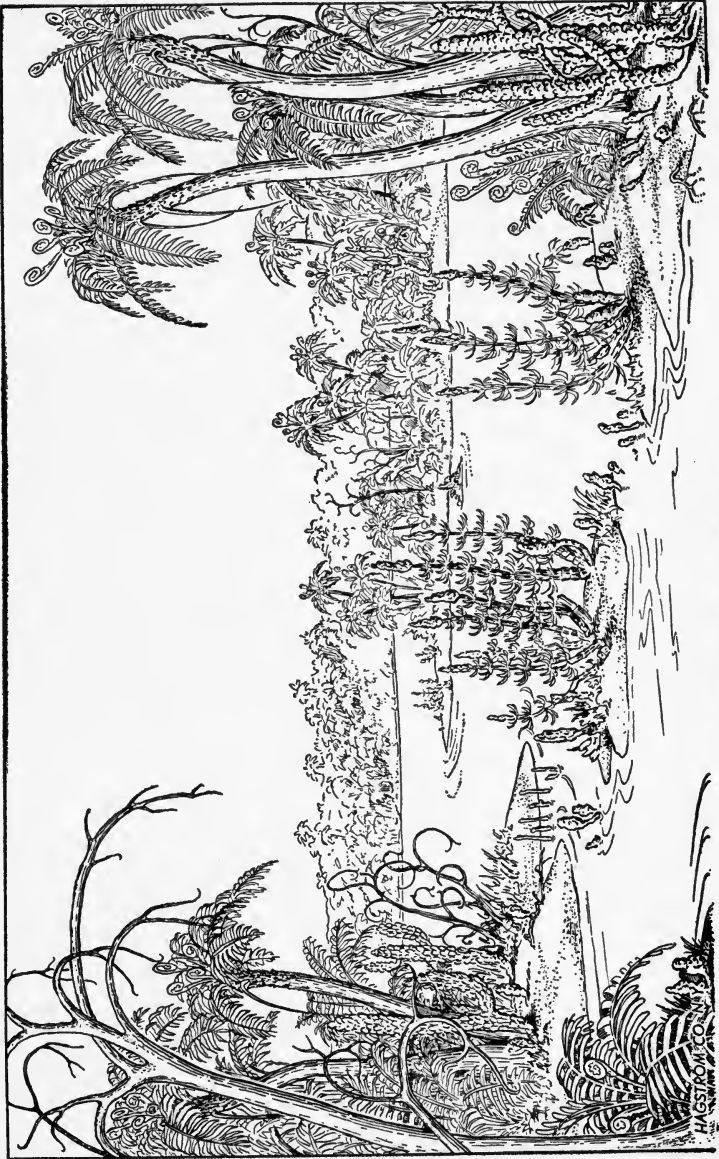

Fig. 191. Devonian Forest  
There were no modern trees.

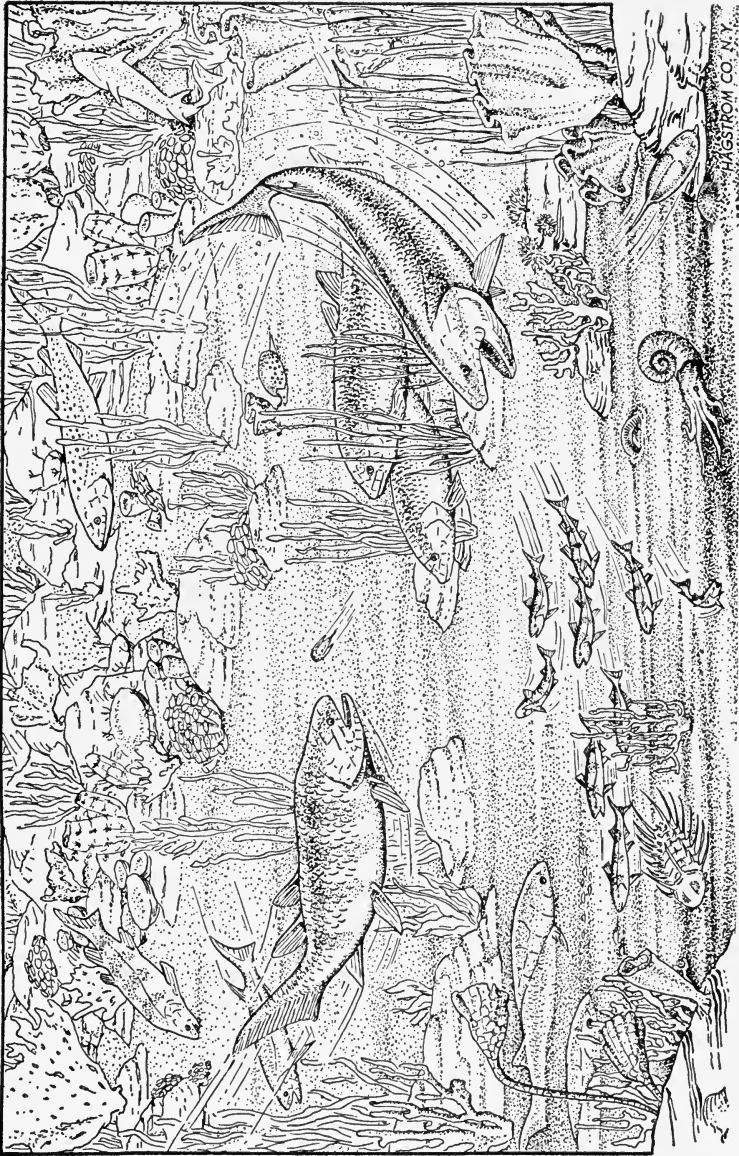

Fig. 192. Devonian Fishes

The forests of this period (Fig. 193) were still quite different from ours today. There were none of the modern trees with the familiar leaves: the oak, maple, beech, and ash. There were still no birds, no mammals, no flowers, no fruits. No sounds broke the somber stillness of the forest, save those of the wind, the thunder, and the babbling brook.

In the following period, the **Permian**, the low-lying lands of the coal-making period began to rise. This brought about a cold climate and widespread aridity. These rather rapid changes in environment seem to have been critical for life, and great changes resulted. The draining of the swamps obliged those plants that had been growing with their feet in the water to adapt themselves to dry land. Most of the trees of the coal-making period disappeared; their place was taken by seed plants, better adapted to the changing climate. The drying up of the swamps was a challenge to the amphibians, which apparently developed into reptiles, animals that live entirely on land. Insects became much smaller and developed a pupal stage, "to tide them over times of climatic stress." But most of the marine invertebrates became extinct, particularly the trilobites.

The drying up of arms of the sea, trapped by the rising land, gave us great deposits of salt and gypsum. In fact, most of the world's salt deposits are Permian in age.

The Permian was the last period of the Paleozoic Era, which was ended by the great Appalachian Revolution, a period of intense mountain making the world over. In the United States, the Appalachian Mountains, five miles high, were formed; and the seas were driven off the lands, never to return again.

★223. The **Mesozoic Era** corresponds to the Middle Ages in world history. It is a transition period between the life of ancient times and that of modern times. The Appalachian Revolution brought with it intensely important physiographic changes. Low-lying lands were raised up into high mountainous areas with correspondingly colder climates, rivers were rejuvenated, and lakes were drained. All of these and many more catastrophes wiped out entire species of plants and animals and introduced new environments, which caused the surviving organisms to undergo vital changes.

During the **Triassic** period, which opened the Mesozoic Era, the



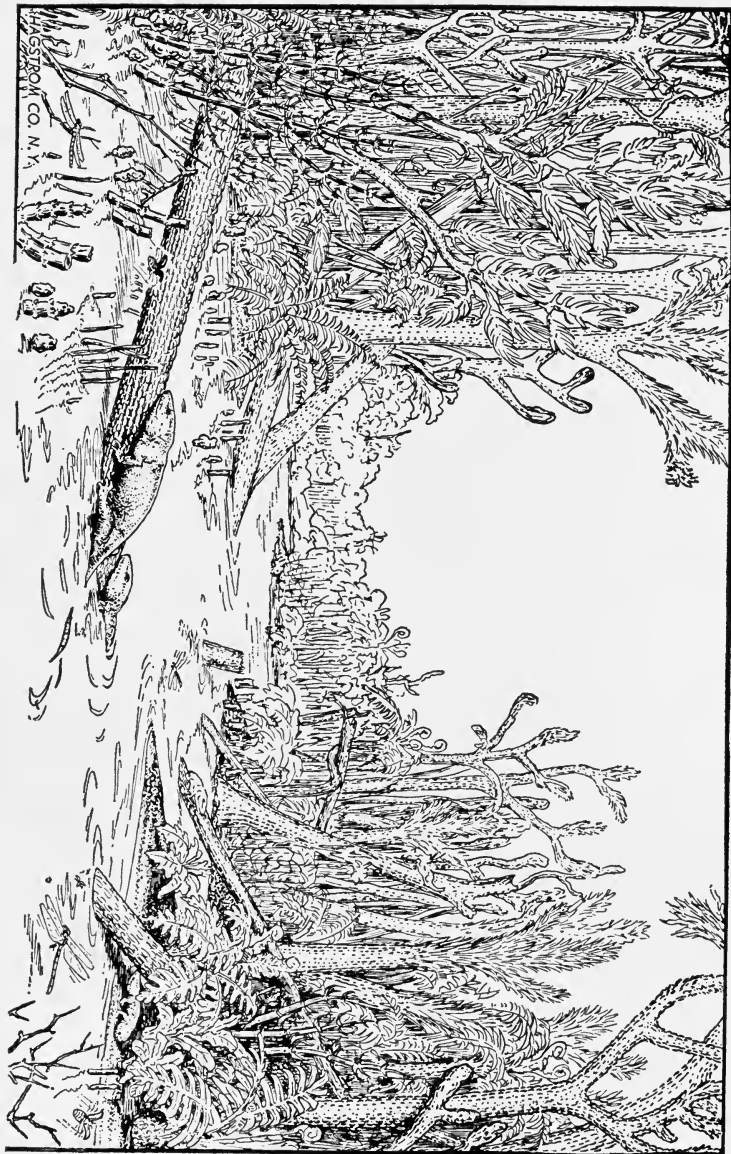

FIG. 193. A Scene in the Pennsylvanian Period

continent of North America looked very much as it does at present, except that the Atlantic and Gulf coastal plains were missing. The prevalence of aridity is shown by the red color of the sedimentary rocks, so strikingly shown in the Painted Desert of Arizona and in Zion Park, Utah. Salt and gypsum deposits in these rocks add further evidence of desert conditions, in marked contrast to the low-lying, moist lands of much of the Paleozoic Era.

A moderate crustal movement, the **Palisade Disturbance**, brought the Triassic to an end. The name is derived from the Palisades on the western bank of the Hudson River, where they form a characteristic feature of the landscape. The Palisades owe their origin to an intrusion of igneous rock into the sedimentary Triassic beds during the Palisade Disturbance. Since that time the overlying softer sedimentary rocks have been worn off, leaving the resistant igneous rock on the surface. The end of the Triassic found the entire continent of North America dry land.

The **Jurassic** period, following the Triassic, resembled it in many respects. The land was high and dry and the Appalachians were eroded down to a peneplain. At the end of the period the **Nevadian Disturbance** lifted up the Sierra Nevada and the coast ranges, giving to western United States something of its present grandeur. Igneous masses injected into the California rocks during this disturbance brought with them the gold deposits which gave us the "Gold Rush of '49."

The life of the Mesozoic Era is quite different from that of the Paleozoic; and while it resembles, or rather foreshadows, the life we know, it is still, in the Jurassic, markedly different.

The forests are made up of cycads and conifers, and while the latter begin to resemble modern evergreen trees, the cycads give to the scene a fantastic appearance (Fig. 194). There are no trees with leaves as we know them: the oak, the maple, the beech, and the ash. The animal world is dominated by monstrous reptiles — not the kinds we know today, but huge, slow-moving creatures. "They filled all the rôles now taken by birds and mammals; they covered the land with gigantic herbivorous and carnivorous forms, they swarmed in the sea, and as literal dragons, they dominated the air."

Brontosaurus attained a length of 65 feet, while diplodocus reached 80 feet. Winged reptiles or pterodactyls gave life to the



Fig. 194. A Scene in the Jurassic Period

air for the first time. Some of them had a 4-foot wing spread. Dinosaurs, known as ichthyosaurs and plesiosaurs, dominated the seas.

The insect world began to take on a modern appearance. Dragonflies, beetles, grasshoppers, cockroaches, cicadas, moths, flies, ants, and others made the air hum.

But what is of greater importance to us is the appearance of a few mammals. They are small and inconspicuous, none of them larger than a modern dog; but already it is evident that they will inherit the earth, because of their adaptation to changing environments. It is thought by some that the necessity to keep its blood warm forced the mammal to move about, and hence arose the necessity for adaptation which brought about rapid development of new characters suited to the changed environment. This increase in complexity gave us the highly developed mammals of modern times.

After the Jurassic came the **Cretaceous**, the *chalk* period, during which there occurred a widespread inundation of the Rocky Mountain area of North America; but by the close of the Cretaceous the land of this region was rising rapidly again, and the continent emerged as it is at present. During this submergence much of the western coal was laid down and the great mid-continent oil field (in Mexico, Texas, and Oklahoma) was formed.

The pterodactyls or toothed birds developed into the feathered variety during this period. Archeopteryx, the first bird, was more reptile than bird. It was about the size of a crow (Fig. 195).

Modern insects, in increasing number, appeared during the Cretaceous, and mammals continued their development. Oysters, lobsters, and other marine forms gave to the seas a slight tinge of the modern.

On the land, magnolia, fig, and poplar trees suddenly appeared and made the forests look distinctly modern. The development of this group of plants, the angiosperms (covered seeds), is of the greatest importance, for they furnish almost all the food of modern mammals. The grasses and cereals, the vegetables, fruits, and nuts are all angiosperms, and it would not be going too far to say that the almost sudden development of birds and mammals followed the appearance of flowering plants. The covered seeds produced by these plants were well adapted to the seasons of cold

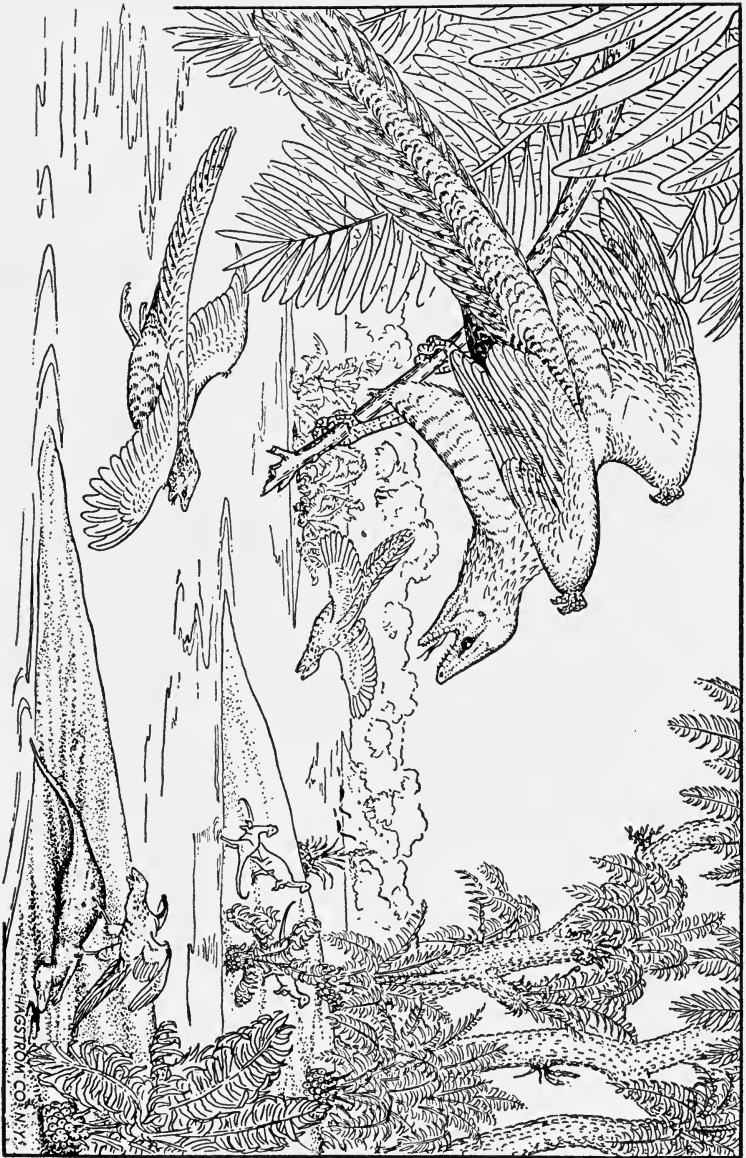

FIG. 195. Archeopteryx, the First Bird

or drought which must have been frequent in the Jurassic, and by the end of the Cretaceous 90% of all plants were angiosperms.

The Mesozoic Era was brought to a close by the Laramide Revolution or "Time of the Great Dying." Not a single dinosaur survived this catastrophe and many of the marine invertebrates disappeared from the seas. The Rocky Mountains were uplifted, with great volcanic activity from Mexico to Alaska, and the Appalachians, which had been worn down to a peneplain, were re-elevated. The continent now assumed its present form and approximately its present topographic features.

**224. The Cenozoic Era.** The last period of earth history is called the Cenozoic, or period of *recent* life. The rocks formed during this period are chiefly loose and unconsolidated sediments and most of them are confined to the continental margins, since seldom did the seas transgress the land. The salt domes of the Gulf states are associated with Cenozoic sands which contain great sulphur deposits, as well as oil and gas. The Monterey formation of California, one of our great oil-bearing rocks, is of Cenozoic age. In the Carolinas and Florida these rocks contain the greatest phosphate deposits of the world; they are formed from animal remains. From about the middle of the era, the Miocene period, intense crustal unrest began in the West and continued with increasing violence to the end, culminating in the **Cascadian Revolution**. In Washington, Oregon, and Idaho, the Columbia and Snake rivers now cut through extensive Cenozoic lava flows which in places are 4,000 feet thick. The Sierra Nevada Mountains were uplifted over a mile, while the Coast Range, in California, was re-elevated and the famous San Andreas Rift developed. It is this break which we believe is responsible for many of the earthquakes experienced in California in recent times. We have evidence that the uplift of the western mountain area is still going on.

The Cenozoic is called the **Age of Mammals**, for although we find mammals in the Mesozoic, they are few and inconspicuous, most of them about the size of a rat. But no sooner has the Laramide Revolution wiped out the dinosaurs, than mammals begin to appear in great number and variety; perhaps because the colder climate suited their warm blood or because their food, the angiosperms, covered the earth.

Early in the era mammals resembling bears, dogs, cats, and



FIG. 196. Early Mammals of the Cenozoic Era

horses, and the first primates are found. During the **Oligocene** the animals begin to look modern; among them are the horse, camel, rhinoceros, peccary, wild dog, and cat. The **Miocene** is the Golden Age of Mammals; herds of horses and camels roamed the

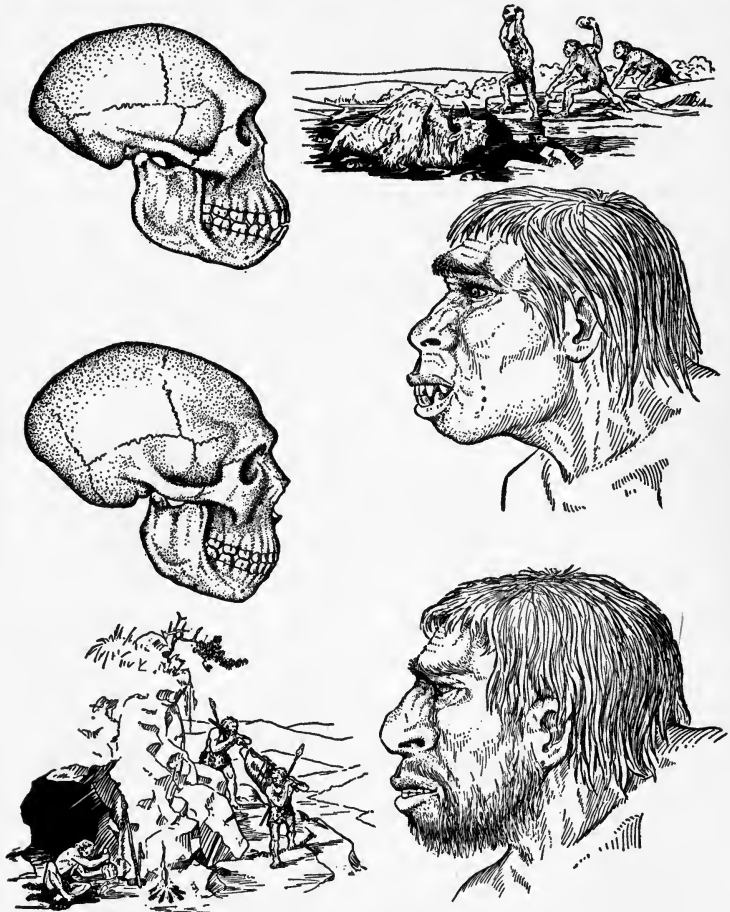

FIG. 197. Early Types of Men

grassy plains, pigs six feet high browsed in the woods, and there were hornless deer, weasels, martens, and raccoons. Mammals now definitely dominate the world.

The primates have disappeared from North America but tailless



apes are found in Europe and Asia. The **Pliocene** is of interest because of the appearance of the first manlike ape in Africa, while in England we find flints (eoliths) evidently made by man (Fig. 197). It is in the **Pleistocene** that man definitely makes his appearance in the warm interglacial periods, about a million and a half years ago; he develops rapidly from manlike ape to apelike man, then to Heidelberg man, to Neanderthal man, and finally to Cro-Magnon man, the beginning of the modern type, about 40,000 years ago.

The most important events of the Pleistocene period were the series of glacial epochs. There were five of them, and the last one ended about 25,000 years ago.

Accumulating in Canada, the ice, several thousand feet thick, moved south in a sheet covering the entire width of the continent. It scoured the surface by removing the rock mantle and planing the bedrock. Deep grooves or striae bear evidence of the great forces at work. Rivers were widened and deepened, and thousands of lakes were formed in Canada and northern United States. The Great Lakes and the Finger Lakes of New York are of glacial origin. The Great Salt Lake is all that is left of the ancient Lake Bonneville, which because of the aridity of the climate has evaporated down to its present size.

The last glacier seems to have reached the line shown on Fig. 85, for we find glacial deposits as far south as that; and the land north of that line shows all the signs characteristic of glaciation. Just why there were five periods of glaciation and whether any more are to follow we cannot say for certain. It may be that we are living in one of the warm periods between glacial epochs; and perhaps there will be other ice sheets advancing from the north, forcing man to take refuge in the warmer parts of the earth.

### ★Completion Summary

Evidence of earth history is preserved in ——— rocks. In these rocks we find fossils, which are ———.

Geologic time is measured in periods and eras, rather than in years. Time in years may sometimes be determined by ———, by ——— denudation and ———, and by ——— of uranium minerals. The oldest rocks are about ——— billion years old.

An unconformity represents an ——— interval during which ——— no history.

During the Archeozoic Era there was life in the warm sea, as shown by ———. The land was ———; volcanic ———.

In the Proterozoic, we find ——— fossils. Volcanic activity ———, but the crust ———, as it did in the Archeozoic. The Archeozoic and ——— together with the ——— lasted about one billion years.

The Paleozoic was a time of great events. The number and variety of fossils ———. The Cambrian opens with ——— life, every class of animal except ——— being represented. Vertebrates appeared in ———. In the ——— the land ——— plants, and the first ———. But the land was not clothed in forest until the ———. Then in the ——— and ——— we had forests which must have been ——— as those of the equatorial regions today. Most of the ——— we use was laid down in those periods. These forests were quite different from ours, since the trees were chiefly ———, with no ——— or ——— or ———. The end of the Paleozoic ——— Appalachian Mountains and wiped out ——— plants and animals of ———.

The Mesozoic Era was dominated by ———. The Palisades of New York and New Jersey were formed at the end of the ———. In the Jurassic, huge ——— roamed the earth, swam ——— and even ——— air. But mammals ———, while a few insects, resembling ———, made their appearance. Modern trees first appeared in ———, together with the ——— and ——— that we know today. The Laramide Revolution ended ———, and destroyed ———.

The Cenozoic Era, known as ———, opened with ——— in great number and variety. In the Oligocene, we have some ——— like those we know today; for example the ——— and ———. The first manlike ape ———, and man-made flints ———. In the ———, man himself ———; first ———, then ———, ———, ———, and finally ———, resembling modern man. In the Pleistocene, occurred five epochs of ———, and it may be that still others are to follow.

**★Exercises**

1. When does earth history begin?
2. What is a fossil?
3. Why are most fossils the remains of marine animals?
4. How can we tell where a highland was in a past age?
5. What kind of rock is deposited at the beginning of a period?
6. What is the normal succession of rocks in a period?
7. What inferences can be drawn from the following succession of rocks: conglomerate followed by sandstone, with limestone on top?
8. Read the history of the near-by land from the following succession of sedimentary rocks: limestone followed by shale, then limestone and shale again.
9. Decipher the meaning of the following strata: conglomerate, sandstone, shale, igneous sill, sandstone.
10. What is an erosion interval?
11. What relation is there between an erosion interval and an unconformity?
12. In what position are sedimentary strata deposited on the continental shelf? Show by diagram.
13. What are varves? How do they help us to determine geologic time?
14. What is the rate of deposition of sediments?
15. What is now considered the most accurate means of determining the time, in years, of past geologic events? On that basis, how old is the oldest rock?
16. Where are the youngest rocks of a series of strata found?
17. How is the age of an igneous intrusion related to that of the sedimentary rocks it pierces?
18. How are periods separated from one another?
19. Why do the fossils of succeeding periods differ?
20. What are formations?
21. How do fossils indicate the climate of a past age?
22. Why are there very few, if any, fossils in the Archeozoic rocks?
23. What indication have we, in Archeozoic rocks, of the existence of considerable plant life?

24. What does the enormous amount of granite gneiss in Canada show about the chief events of the Archeozoic?

25. How do we know that the Archeozoic Era was ended by a period of mountain formation followed by a long period of erosion?

26. What is meant by pre-Cambrian?

27. What evidence might be found in the rocks of Greenland, Scandinavia, and Canada to show that all three were joined in the Proterozoic?

28. What is the evidence of extensive volcanic activity in the Proterozoic?

29. How do we know that the earth's crust did not crack so often in the Proterozoic?

30. What can be inferred from the vast ore deposits laid down in the Proterozoic?

31. Show that the life of the Proterozoic supports the theory of evolution.

32. How do we know there was much more carbon dioxide in the early atmosphere than there is today?

33. What is meant by a revolution, in earth history?

34. Why do we believe the Lipalian Interval lasted a long time?

35. What are trilobites?

36. Describe the land during the Cambrian.

37. Why are most of the Ordovician rocks limestones?

38. What vertebrates appeared first? When?

39. Is there any possible connection between the appearance of the first land plants and the first land animals in the Silurian?

40. What important development in life started in the Devonian?

41. When did insects become common?

42. What is meant by the "age of coal"?

43. How did the Pennsylvanian forest differ from ours?

44. What does the presence of much salt in Permian deposits mean?

45. When were the Appalachian Mountains raised?

46. Why are the animals and plants of the Mesozoic so different from those of the Paleozoic?

47. When did this continent begin to look as it does today?

48. Explain how the Palisades were formed and came to their present condition.

49. Why were the Triassic and Jurassic periods generally arid?
50. When did western United States begin to look mountainous, somewhat as it does today?
51. In what way did the forests of the early Mesozoic differ from those of today?
52. What animals dominated the Mesozoic?
53. What animals of the Jurassic resembled those of today?
54. When did mammals first appear?
55. Why were mammals better adapted to the conditions of the Mesozoic than reptiles?
56. Of what economic importance are Cretaceous rocks in central United States?
57. When did the first bird appear? What is it called?
58. Which of the modern trees appeared first? When?
59. What relation may exist between the rise of angiosperms and of mammals?
60. Why is the Laramide Revolution called "Time of the Great Dying"?
61. When were the Rocky Mountains uplifted?
62. When were the Appalachian Mountains re-elevated?
63. Of what economic value are the Cenozoic deposits of the Gulf States? Florida? California?
64. When was the Columbia River Plateau formed?
65. What is the age of mammals?
66. When did many of our domestic animals appear?
67. When does evidence of man appear in England?
68. When did man appear?
69. Name some of the types of early man.
70. Which type of man do we resemble?
71. About how long ago did Cro-Magnon first appear?
72. What is the outstanding event of the Pleistocene?

## CHAPTER XIX

### THE EARTH IN SPACE

**225.** The earth is a ball nearly 25,000 miles around, and about 8,000 miles in diameter. It is composed of rock, with about three quarters of its surface covered by oceanic waters. Both rock and water are enveloped in air.

The earth has many movements, although it appears to us that it is at rest because of the uniformity of these movements and the fact that we partake of all of them. It sometimes happens that a train begins to pull out of the station very slowly and without the slightest jar. A passenger on that train who happens to be looking at a neighboring train sometimes imagines that *his* train is at rest while the other one is moving. He discovers his error when he sees posts and other objects moving away from him. We are accustomed to being jounced and jarred by a moving vehicle and to seeing objects fly past us. But the earth moves smoothly without the slightest jar and although objects do move past us, we think *they* are in motion — not we. *They are* — everything is — in motion.

We shall study only two of these earth motions: its rotation on its axis, the time of which we call a *day*, and its revolution about the sun, which marks off the *year*.

The earth is only one of a family of rotating and revolving spheres controlled by the sun and called the solar system. A little study of the earth's relation to these other heavenly bodies will make clear many things, particularly with respect to time and seasons.

**226. Form and size of the earth.** The earth's shape is *almost* spherical (Fig. 198). The diameter from pole to pole is *27 miles shorter* than the diameter at the equator. We

believe this is due to the effect of the centrifugal force of the earth's rotation on its plastic interior (Fig. 199).

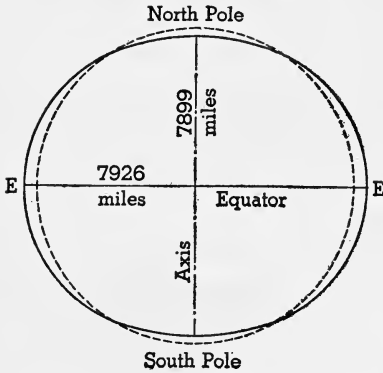

FIG. 198. The Form and Size of the Earth

The dotted line is a circle.

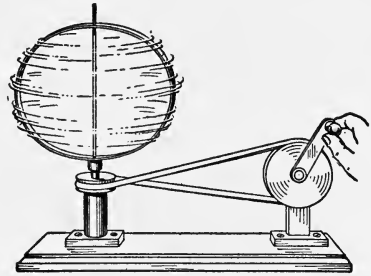

FIG. 199. Centrifugal force causes a hoop to bulge at its equator.

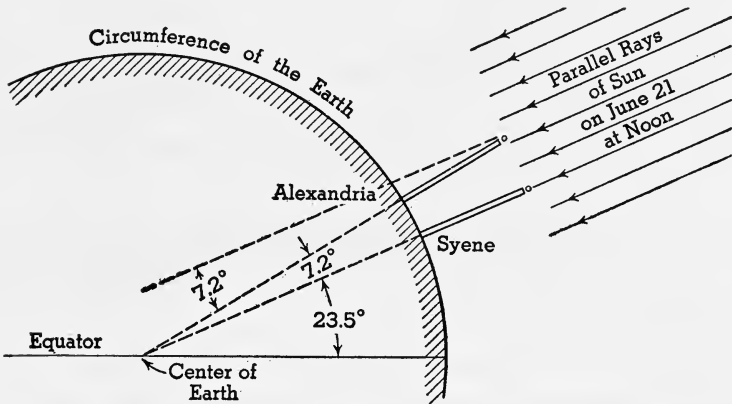

FIG. 200. How Eratosthenes Measured the Circumference of the Earth

The surface area of the earth is nearly 200 million square miles, of which a little more than 50 million square miles are land.

★The first successful attempt to measure the size of the earth was made about 200 B.C. by Eratosthenes, an astronomer and geographer of Alexandria, in Egypt. He learned that, at Syene,

the most southern city of ancient Egypt, a vertical pillar cast no shadow at noon on June 21. At Alexandria, 5000 stadia directly north of Syene, the sun's noon ray, on the same day, made an angle of  $7.2^\circ$  with a vertical pillar (Fig. 200). Assuming the earth to be a sphere, a line through a vertical pillar, anywhere, passes through the center of the earth.

Since the sun's rays are parallel, we have here a simple problem in geometry. The angle at the center of the circle, which subtends the arc from Alexandria to Syene, is  $7.2^\circ$  (alternate interior angles made by parallel lines). Since the entire circumference is  $360^\circ$ , or  $50 \times 7.2^\circ$ , it must be 50 times the distance from Alexandria to

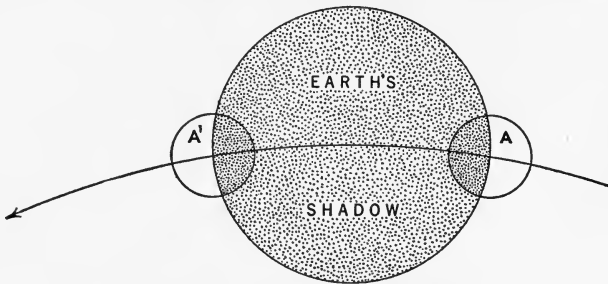

FIG. 201. An Eclipse of the Moon

The earth's shadow is always the arc of a circle.

Syene, or 250,000 stadia. We now know that the distance between these two places is about 500 miles, giving 25,000 miles as the circumference.

### 227. Evidence that the earth is spherical.

1. As ships sail away, their hulls gradually disappear; and as they approach, their tops appear first. Before any part of the approaching vessel is seen, smoke often appears to be coming out of the water; then the smokestack comes in view. This shows that the water surface between the observer and the ship is actually curved so as to hide the distant ship.

This curvature is found to be the same in all directions on water surfaces, and consequently the earth is a sphere.

2. During every eclipse of the moon by the earth, that portion of the shadow of the earth cast on the moon always has a curved edge, apparently the arc of a circle. In Fig. 201



the moon, moving to the left, is entering the earth's shadow at *A* and leaving it at *A'*. The curved edge of the earth's shadow shows that the form of the earth is spherical, because the shadow is *always* circular.

3. Circumnavigation proves the earth to be spherical. By traveling in one direction, a person always returns to

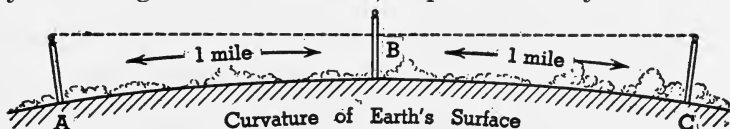

FIG. 202. Evidence of the Earth's Curvature

See paragraph 227. (4).

the same place; and the distance is always the same, in whatever direction he travels.

This has been accomplished many times by ship and by airplane.

4. On the shores of a calm lake, away from tides and swells, the curvature of the earth may be measured directly

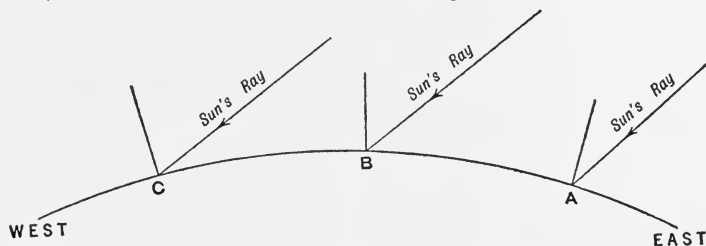

FIG. 203. Effect of the Earth's Curvature on Time

The parallel rays of the sun strike points farther west at smaller angles.

by erecting in a straight line three posts, *A*, *B*, and *C*, a mile apart (Fig. 202), at the same height above the surface of the water. If a telescope is sighted along the top of post *A* to the top of *C*, the line of sight will run 8 inches below the top of post *B*. This can only be because of the earth's curvature.

5. As a result of the curvature of the earth, places on the earth to the east or west have different time.

In Fig. 203, if at *A* it is 10 o'clock, then at *B*, farther west,

it is earlier, perhaps 9 o'clock, and at *C*, 8 o'clock, all, of course, at the same instant. If the earth's surface were flat, all places would have the same time.

★6. The weight of a body at sea level is about the same everywhere on the earth's surface. According to the Law of Gravitation, the weight of a body is a measure of the attraction between the earth and the body. A body farther away from the earth's center, as on a mountain, weighs less, because the attraction is less when the bodies are farther apart.

Since the weight of a body at sea level is about the same everywhere on the earth's surface, it must be the same distance from the center of the earth. Therefore the earth is a sphere.

Actually, a body weighs more near the poles than at the equator, which proves in another way the flattening at the poles.

**228. The rotation of the earth.** The uniform spinning motion of the earth on its shortest diameter is called *rotation*. The shortest diameter, connecting the *poles*, is called the *axis* of rotation. The line around the earth midway between the poles is the *equator*.

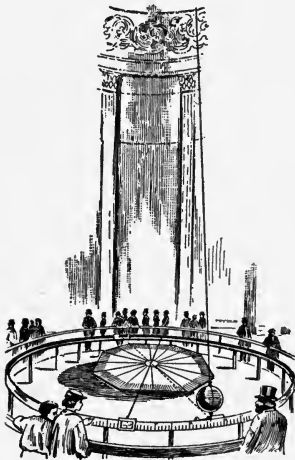

FIG. 204. Foucault's Experiment

As late as 1632, the time of Galileo, there was strong doubt as to the daily turning of the earth on its axis. The first experimental proof that the earth actually rotates was obtained in 1851, and later experiments have proved it conclusively.

★In 1851 the physicist Foucault devised a remarkable proof of the earth's rotation by means of a pendulum.

From the dome of the Pantheon in Paris he hung a heavy iron ball by a steel wire more than 200 feet long. The pendulum was started swinging back and forth in a plane, and, as time went on, it swung over different lines on the floor. Either the pendulum was gradually moving around a circle or *the floor was turning* (Fig. 204).

We know that because of *inertia* the plane of vibration of a pendulum never changes. Hence the conclusion must be that the floor of the Pantheon, in other words, the earth, is turning about an axis.

We find that the sun, the other planets, and some of the satellites are all in rotation. One of them rotates in  $10\frac{1}{2}$  hours, another in about 24 hours, like the earth, and some require months.

**229. Effects of rotation.** We know now that one complete rotation occurs in a day, and that, in consequence, the sun, moon, and stars rise in the east, pass through the sky, and set in the west; or at least they seem to, though actually we know that their apparent movements are due to the *earth's* rotation.

As the earth receives its light from the sun, the side, or half turned toward the sun, is in light and has day. At the same time the opposite side is in shadow and has night (Fig. 205). As the earth rotates from west to east the light moves gradually toward the west; that is, the sun rises

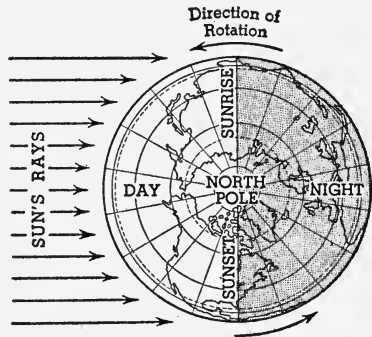

FIG. 205. The rotation of the earth causes day and night.

in the east and sets in the west.

**230. Star trails.** Figure 206 is a sort of moving picture of the northern sky at night. If it were a snapshot, each star, somewhere on a circle, would make a point of light on the picture, but there would be no circles. The photograph was taken by pointing a camera toward the northern sky on a clear moonless night and exposing a plate for  $9\frac{1}{2}$  hours. During that time the earth, turning around, carried the plate along in the arc of a circle while the stars remained fixed. Notice that the trails are not complete circles. For example, the trail at the center was made by the Pole Star itself, which is near but not exactly at the north pole of the sky.

The stars appear to be revolving about this *celestial north pole*, which is the continuation of the earth's axis.

The North Star was focused at the center of the plate. The actual length of any trail will depend upon the distance from the North Star, but the *number of degrees* in the arcs is



FIG. 206. Star Trails

the same for all the trails. Since the earth rotates  $360^\circ$  in 24 hours, in one hour it will move  $15^\circ$  about its axis. Therefore each of these trails should be an arc of  $9\frac{1}{2} \times 15^\circ$  or  $142.5^\circ$ .

The stars appear to be moving about the North Star in an anticlockwise direction; that is, the stars above the North Star appear to move westward, those below eastward.

This apparent motion of the circumpolar stars is caused by the real motion of the earth; hence the apparent anti-

clockwise direction is due to the turning of the earth in a clockwise direction.

The actual number of miles which a point on the earth's surface moves because of rotation depends upon its distance from the equator. At the pole this is zero; at the equator, 25,000 miles in 24 hours. In latitude  $40^\circ$ , near New York City, it is about 800 miles an hour; at  $60^\circ$ , about 500 miles an hour. But the *angular rate of rotation*,  $15^\circ$  per hour, is everywhere the same; and this furnishes us the most accurate timepiece known. All clocks and watches are regulated by it.

**231. The earth's revolution about the sun.** The path of the earth about the sun is called its orbit, and the journey takes a few minutes less than  $365\frac{1}{4}$  days. This period of revolution determines the length of our *year*.

The time it takes the other planets to go round the sun differs greatly. One planet revolves four times while the earth revolves once, whereas other planets require scores of earth years to make one complete journey around the sun. The rate of the earth's revolution is over 66,000 miles an hour.

**232. Change of season.** As the earth moves forward in its orbit its axis remains tipped, or inclined, in the same direction and always the same amount. The inclination of the earth's axis is  $23\frac{1}{2}^\circ$  from the perpendicular to the plane of the earth's orbit (Fig. 207). In other words, the earth's axis is *always* inclined  $23\frac{1}{2}^\circ$  and therefore it is always parallel to itself.

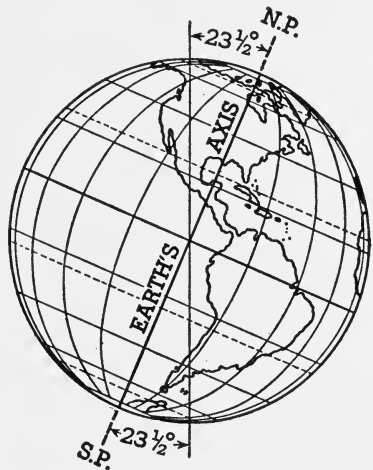

FIG. 207. The earth's axis is inclined  $23\frac{1}{2}^\circ$  from the perpendicular to the plane of the earth's orbit.

The causes of the regular change of season may be stated as due to:

1. Inclination of the earth's axis
2. Its parallelism
3. Revolution about sun

If the earth's axis were perpendicular to the plane of the earth's orbit, the sun would each day pass through the sky in the same path; all our days would be of equal length and we should have no change of season. Any place on the earth would receive the sun's noon rays at a certain angle which would not change from day to day. The sun would rise at the same time each day, and set at the same time; and weather and climate, which depend so much on the amount of heat received from the sun, would be more uniform throughout the year, and year after year.

Or if the axis *were* inclined, and there were no revolution, then, while days and nights would not be 12 hours each, they would remain the same for any particular place, the amount of heat received from the sun would still be the same for each day, and again there would be no change of seasons. *The change of seasons depends then on both inclination and revolution.*

Because of the inclination of the earth's axis, the sun passes through the sky at a much higher elevation in summer than in winter. This higher elevation of the sun causes longer days, and we get the sun's rays at a more nearly vertical angle; hence, we have summer. If the inclination of the earth's axis was more than  $23.5^{\circ}$ , the change of seasons would be more pronounced; that is, our summers would be warmer and our winters colder than they are now.

The regular change of seasons depends upon the earth's axis remaining parallel. The length of each season depends upon the time of revolution. Should the earth require a longer time to go around the sun, the seasons would be correspondingly longer.

The orbit of the earth has the form of an ellipse, but it

is nearly circular because the two foci of the ellipse are near together. The sun is at the north focus, and the earth, about January 1, is about 91,500,000 miles from the sun. This point on the orbit, called *perihelion*, is the nearest to

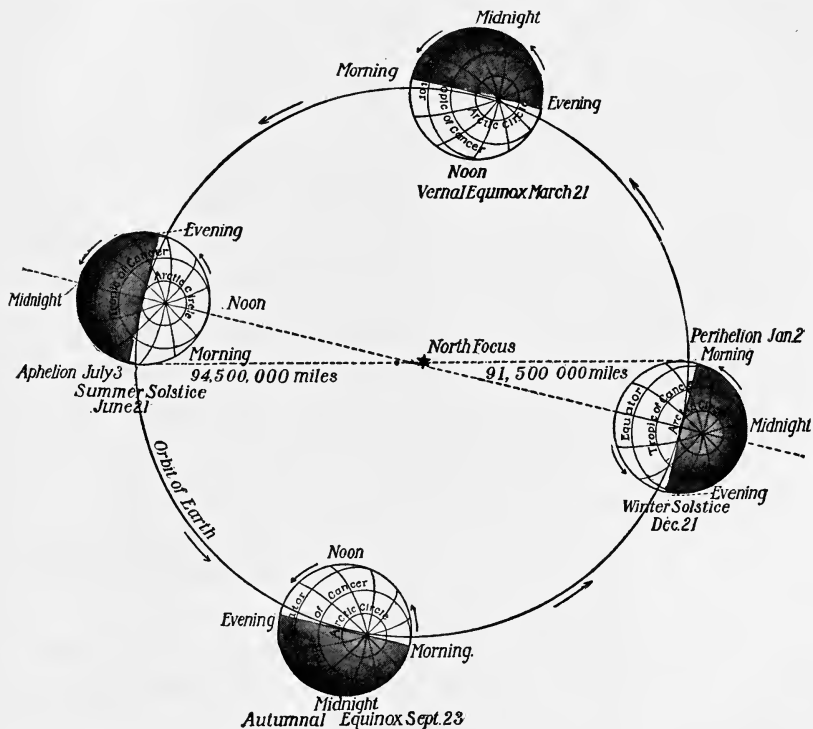

FIG. 208. Four Positions of the Earth in Its Orbit about the Sun Corresponding to the Four Seasons

the sun. On July 1 the earth is farthest from the sun, at *aphelion*, 94,500,000 miles away.

This change in distance has little effect on the seasons. As a matter of fact our northern *winter occurs when the earth is nearest to the sun*, at perihelion, and our summer occurs at aphelion.

In Fig. 208, the earth is shown in four positions, as it makes its annual journey around the sun. Each position

shows the earth at the beginning of a season. On June 21, the North Pole, turned toward the sun (Fig. 209), is in the

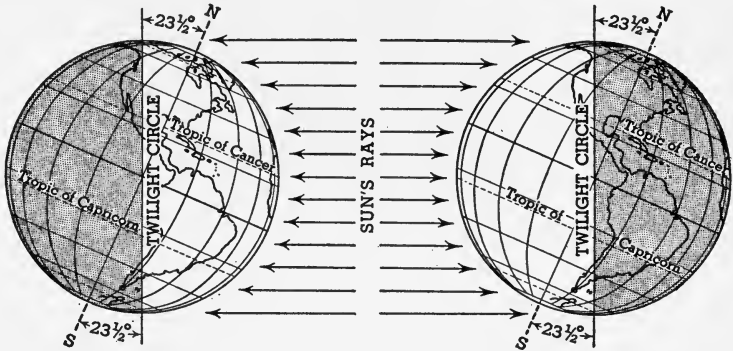

FIG. 209. The Earth on June 21 . . . FIG. 210. The Earth on Dec. 21

middle of a six months' period of sunlight. The South Pole at the same time is turned away from the sun, and it is in the middle of a six months' period of darkness. Summer is beginning in the northern and winter in the southern hemisphere.

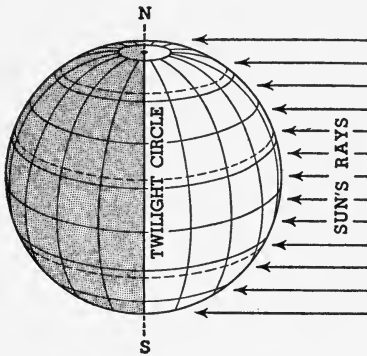

FIG. 211. The Earth on Sep. 23 and Mar. 21

The daylight circle is just touching the polar circles and the sun's vertical ray is at the Tropic of Cancer.

On December 21 (Fig. 210), the South Pole is tipped toward the sun and it is in the middle of six months of daylight. The North Pole is in

darkness for six months. Summer is beginning in the southern and winter in the northern hemisphere.

The daylight circle is just touching the polar circles, and the sun's vertical ray is at the Tropic of Capricorn.

On September 23 (Fig. 211) and on March 21, the sun's rays are perpendicular to the earth's axis. Days and nights



are twelve hours each, all over the earth. On March 21, spring is beginning in the northern and autumn in the southern hemisphere. The daylight circle passes through the poles and the sun is vertical at the equator.

**233. Cause of unequal days and nights.** Figure 212 shows the longest day at different points in the northern hemisphere. At the equator it is 12 hours and increases as we move north, until at the pole it is *6 months*.

The same factors that cause change of seasons are responsible for the changes of the length of day and night.

At the equator the length of days and nights is always equal. The farther we go from the equator, either north or south, the greater is the difference in length between day and night; in summer the days are long and the nights short, and vice versa in winter.

The fundamental cause of this inequality of the length of days at different times of the year is the inclination of the earth's axis. If it were inclined more than  $23\frac{1}{2}^{\circ}$ , our summer days would be longer and our winter days shorter than they are now.

On March 21 and September 23, the sun's vertical ray being at the equator, the sun rises due east and sets due west, and the days are everywhere equal in length to the nights. (See Figs. 213, 214, 215, and 216.) These two dates, March 21 and September 23, are called the *equinoxes* (equal nights). On March 21, the *vernal* or spring equinox, the sun is said "to cross the line," as it passes from the southern to the northern side of the equator. On September 23, at the autumnal equinox, the sun crosses the line again, from the northern to the southern side of the equator.

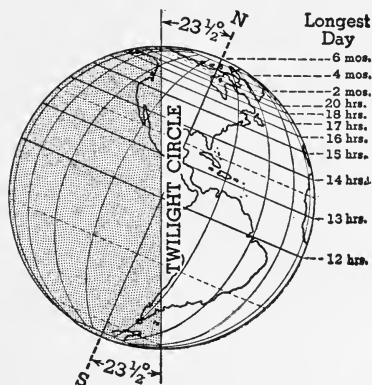

FIG. 212

From the vernal to the autumnal equinox the sun rises north of east (Mar. 21 to June 21 and back to Sept. 23 in Fig. 214) and sets north of west; and in the northern hemisphere the days are longer than the nights, and vice versa in the southern

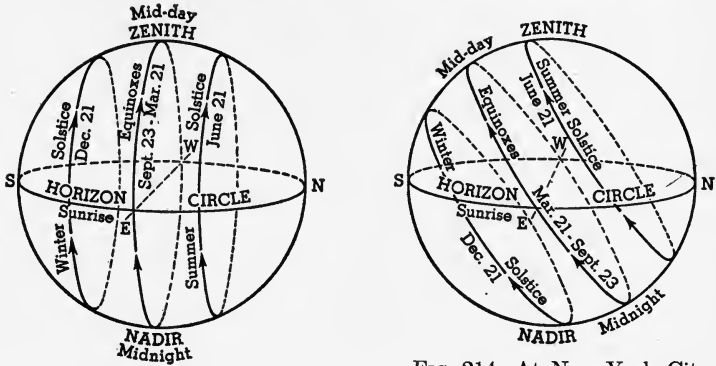

FIG. 213. At the equator the apparent sky path of the sun is always perpendicular to the horizon, and days and nights are equal at all times of the year.

The observer is at the center of the horizon circle.

FIG. 214. At New York City,  $41^{\circ}$  N latitude, the apparent sky path of the sun is tipped toward the south, giving us long days in summer and short days in winter.

The direction of sunrise and sunset may be read from the figure.

hemisphere. From the autumnal to the vernal equinox, the sun rises south of east and sets south of west; and in the northern hemisphere the days are shorter than the nights, and vice versa in the southern hemisphere.

The apparent northward journey of the sun ends on June 21, called the *summer solstice*. The word *solstice*, translated literally from the Latin, means "the sun stands." The southern journey ends on December 21, called the *winter solstice*, when the *sun stands* before starting northward.

As shown in Fig. 213, the daily sun paths at the equator are always perpendicular to the horizon, and all days and nights are equal at all times of the year. The middle sun path is actually the same as the sky equator. It shows that a vertical sun is over the earth's equator only at the equi-

noxes. The sun paths at the time of the solstices are  $23\frac{1}{2}^{\circ}$  from the sky equator.

At the time of the summer solstice the sun is vertical at the Tropic of Cancer; at the winter solstice, at the Tropic of Capricorn; each  $23\frac{1}{2}^{\circ}$  from the equator.

In Fig. 214, at New York City, latitude  $41^{\circ}$  north, the paths are tipped toward the south, an angular distance from the perpendicular equal to that of the latitude. This is true for all latitudes from the equator to the North Pole. South of the equator the same relation holds, but the sun paths are inclined north. Here the long days in summer and short days in winter are shown by relative length of sun paths above the horizon on June 21 and December 21. The departure of sunrise from due east and sunset from due west is considerably more than at the equator.

In Fig. 215, the sun paths are inclined  $66.5^{\circ}$  from the perpendicular, that being the latitude of the Arctic Circle. Here the sun path for June 21 just touches the horizon at one point, due north; in other words, the sun is above the horizon for 24 hours and *there is no night*. From any position on the Arctic Circle on June 21 an observer would have an opportunity to see the sun, due north and on the horizon, *at midnight*; or, at least, it is 12 o'clock of what, farther south, would be called night.

At this latitude on December 21 the sun would just appear on the horizon at midday and then would set again.

In the polar regions, however, where periods of light and darkness may be many days or weeks, the habit of regularity of rest and activity is not generally formed. In the long summer day, when the sun never sets, the opportunity for cultivating fields or harvesting crops must not be missed, and the entire family will work 15 hours a day or even longer, until they are worn out, before they seek repose. One can see boys playing outdoor games at 1 o'clock in the morning.

The earth's rotation furnishes a simple way to find geo-

graphical directions. The sun rises *approximately* in the east and sets in the west. That is exactly true only at the equinoxes. The midday sun shows us which way is south, and the Pole Star at night marks north for those of us who live in the northern hemisphere. (See *North Star*, Fig. 220, next chapter.)

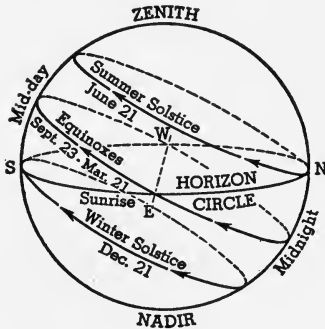

FIG. 215. At the Arctic Circle,  $66.5^\circ$  N latitude, the apparent sky path of the sun on June 21 is above the horizon, and on Dec. 21 it is below the horizon for 24 hours.

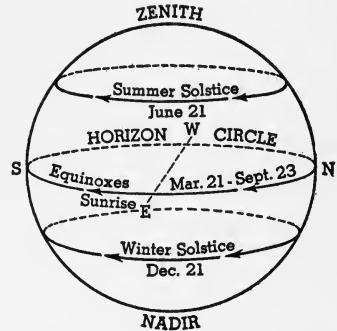
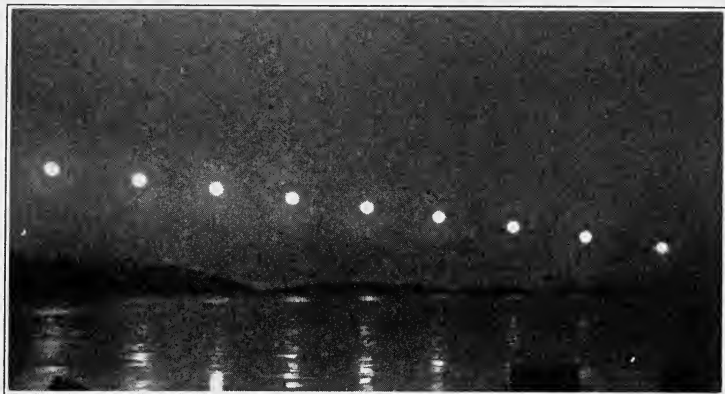

FIG. 216. At the North Pole, the apparent sky paths of the sun are nearly horizontal. The year is divided into two periods: sunlight and darkness.

★In Fig. 216, at the North Pole, the sun paths are parallel to the horizon. The pole is  $90^\circ$  north latitude, and the sun path is inclined  $90^\circ$  from the perpendicular. At the time of the equinoxes the sun paths are at the horizon. The sun is said to rise at the vernal and to set at the autumnal equinox, causing a period of continuous sunlight for six months. During any period of 24 hours, the sun apparently moves through the sky approximately at the same distance above the horizon. Should the altitude of the sun at intervals of 12 hours be found to be about the same, it would be proof that the observer was approximately at the North Pole.

As the sun sinks below the horizon, about September 23, not to appear again until about March 21, there is a period of six months without direct sunlight. This six-month period is not entirely devoid of light. For nearly two months there is a gradual fading twilight, due to refraction, as the sun continues to sink lower below the horizon.

For about two months all light from the sun is cut off, except that reflected by the moon. The dawn begins nearly two months before the sun finally appears again at the horizon on March 21.



*Courtesy of Donald MacMillan*

FIG. 217. The Midnight Sun at Intervals of 20 Minutes  
Its path corresponds to that shown in Fig. 215 for June 21.

### *Completion Summary*

The shape of the earth is almost ———. The equatorial diameter is ——— longer than ———. About ——— of the surface is ———, the rest ———.

★Eratosthenes first ——— about ——— miles.

An approaching vessel at sea appears ——— first, because ———.

The shadow of the earth on the moon is ———, proving ———.

★If the earth were not a sphere, the weight of a body, which is a measure of ———, would be ——— at different places.

Foucault, with a long ———, proved ———.

The sun, moon, and other heavenly bodies apparently rise ——— and set ——— because the earth ———.

The length of the year is caused by the earth's ——— sun.

Change of season is due to \_\_\_\_\_ and \_\_\_\_\_.  
 \_\_\_\_\_ also causes the length of the day \_\_\_\_\_.

At \_\_\_\_\_, the earth is 91,500,000 miles from the sun, while at \_\_\_\_\_, it is \_\_\_\_\_ miles from the sun.

On Sep. 23 and Mar. 21, the sun's rays are \_\_\_\_\_, and therefore \_\_\_\_\_.

At the equator, the length of the day \_\_\_\_\_. Farther north, the days \_\_\_\_\_ in summer, until above the Arctic Circle, they may be \_\_\_\_\_ and at the pole \_\_\_\_\_. The sun \_\_\_\_\_ continuously for more than 24 hours anywhere north of \_\_\_\_\_ on \_\_\_\_\_.

Sep. 23 and Mar. 21 are called \_\_\_\_\_ because \_\_\_\_\_. From Mar. 21 to Sep. 23, the sun \_\_\_\_\_ east and sets \_\_\_\_\_ west. The apparent northward journey of the sun \_\_\_\_\_ on \_\_\_\_\_ at the Tropic \_\_\_\_\_. This date is called \_\_\_\_\_. On Dec. 21, the sun \_\_\_\_\_ southern journey and begins \_\_\_\_\_. This date is called \_\_\_\_\_.

At midday, the sun is exactly on \_\_\_\_\_ line, from which we can get direction.

### *Exercises*

1. Why is the polar diameter of the earth shorter than the equatorial diameter?
2. What part of the earth's surface is covered by water?
3. What evidence that the earth is not flat is furnished by vessels at sea?
4. How does a lunar eclipse prove that the earth is a sphere?
5. How does circumnavigation prove that the earth is spherical?
6. Show by diagram how the earth's curvature might be measured directly.
7. What is meant by rotation of the earth?
8. What is the axis of the earth? Show by diagram.
9. Why do the sun, moon, and stars seem to rise in the east and set in the west?
10. Explain the cause of day and night.
11. How do star trails prove the earth's rotation?

12. Explain how to tell time by the earth's rotation.
13. What determines the length of the year?
14. State, in degrees, the inclination of the earth's axis.
15. If the earth's axis were perpendicular to its orbit, how would that affect the length of the day?
16. How would a perpendicular axis affect the seasons?
17. How would a perpendicular axis affect weather and climate?
18. Explain how change of seasons depends on both inclination and revolution.
19. How would the seasons be affected if the earth revolved about the sun in 730 days?
20. What is the shape of the earth's orbit?
21. What is perihelion? aphelion?
22. Why does our winter occur when the earth is nearest the sun?
23. When does the long polar day begin?
24. When does summer begin? winter?
25. Where is the Tropic of Cancer? Capricorn? What relation have these to the inclination of the earth's axis?
26. Why do we start spring on Mar. 21, and autumn on Sep. 23?
27. What locates the Arctic Circle?
28. When do days and nights have the same length all over the earth? What name is given to these days?
29. Where do we find the greatest variation in the length of day? the smallest?
30. On Dec. 15, about where does the sun rise, in the north temperate zone?
31. What is meant by the summer solstice? the winter solstice?
32. In about what latitude are the noon rays of the sun vertical on Jan. 1? Mar. 1? July 1? Sep. 1?
33. At the dates mentioned in question 32, which is longer here: day or night?
34. At the above dates does the sun here rise north or south of east?
35. When does the sun shine into windows facing north?
36. Where can the midnight sun be seen?
37. Can the day ever be longer than 24 hours? Where?

**★Optional Exercises**

38. Explain, by diagram, Eratosthenes's method of finding the circumference of the earth.

39. How can the approximate shape of the earth be proved by gravitational measurements?

40. Describe Foucault's proof that the earth rotates on an axis. Explain the part played by inertia.

41. How does the rotation of the earth provide us with a means of keeping time?

42. Show that if the inclination of the earth's axis were more than  $23.5^\circ$ , we should have more extreme seasonal changes.

43. Explain why the polar day actually lasts *more* than 6 months.

44. Explain why day and night are always equal at the equator.

45. Explain why day and night are everywhere of equal length at the equinoxes.

46. Would there be any daylight at all on Jan. 1 north of the Arctic Circle? Explain.



## CHAPTER XX

### LATITUDE, LONGITUDE, AND TIME

**234. How do we locate places on the earth?** The intersection of two lines determines a point, and if a house is located by saying it is on the northwest corner of A Street and B Avenue, any person familiar with those streets could locate the house.

In locating points on the earth's surface, which is spherical, we use a system of two sets of lines at right angles to each other, called *parallels of latitude* and *meridians of longitude*.

The equator is the circle drawn around the earth midway between the poles. It has  $0^\circ$  latitude. Other circles drawn around the earth parallel to the equator, in other words equally distant from the equator at all points, are the parallels of latitude. Each circle gets smaller and smaller until, at the North Pole, the circle is a dot.

Since we are dealing with circles, which are conveniently divided into  $360^\circ$ , we call the distance from the equator to the pole, which is one quarter of a circle,  $90^\circ$ . The North Pole is therefore at  $90^\circ$  north latitude and the South Pole at  $90^\circ$  south latitude. When we draw a map, we locate on it as many parallels of latitude as are convenient between  $0^\circ$  and  $90^\circ$  (Fig. 218).

In locating the latitude of a particular place, if it does not fall exactly on a degree of latitude, we divide the degree into 60 parts, called *minutes*, and, for still more precise work, a minute is divided into 60 seconds. The place may be on a parallel of latitude 41 degrees 22 minutes 45 seconds north of the equator; that would be designated  $41^\circ 22' 45''$  N lat. in common practice.

A degree of latitude is roughly 70 miles ( $25000 \div 360$ ).

Because the equatorial bulge makes the curvature of the earth's surface grow gradually less from the equator toward the pole, degrees of latitude increase slightly in length toward the poles.

**235. Finding latitude by night.** The latitude of an observer in the northern hemisphere may be found on any clear night by means of the North Star, Polaris. The number of degrees of a heavenly body above the horizon is called its

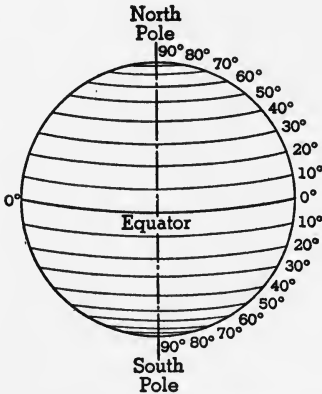

FIG. 218. Parallels of Latitude

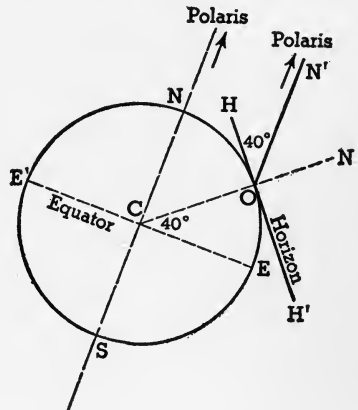

FIG. 219. Finding Latitude by Observation on Polaris

*altitude.* At the equator the North Star appears on the horizon and its altitude is consequently zero. At  $40^\circ$  north of the equator the North Star is  $40^\circ$  above the horizon (altitude  $40^\circ$ ), and at the North Pole of the earth it is directly overhead, or in the *zenith*; hence its altitude is  $90^\circ$ .

The altitude of the North Star in the northern hemisphere equals, therefore, the latitude of the place where the observation is made.

★These relations are shown by simple geometry in Fig. 219. An observer at  $O$  finds the altitude of Polaris, angle  $HON'$ , and that is his latitude, since that angle is equal to angle  $OCE$  (as  $HH'$  is perpendicular to  $CO$ ; and  $N'O$ , which is parallel to  $NS$ , is perpendicular to  $CE$ ). In Fig. 219 the latitude of  $O$  is  $40^\circ N$ .

It may be surprising to find all these lines, toward Polaris, parallel to each other, until we remember that the star is so far away (much farther than the sun) that all lines from it to the earth must be practically parallel.

Since Polaris is not exactly at the north pole of the sky, but describes a small circle about it every day, we must, for precise work, make a small correction (Fig. 220).

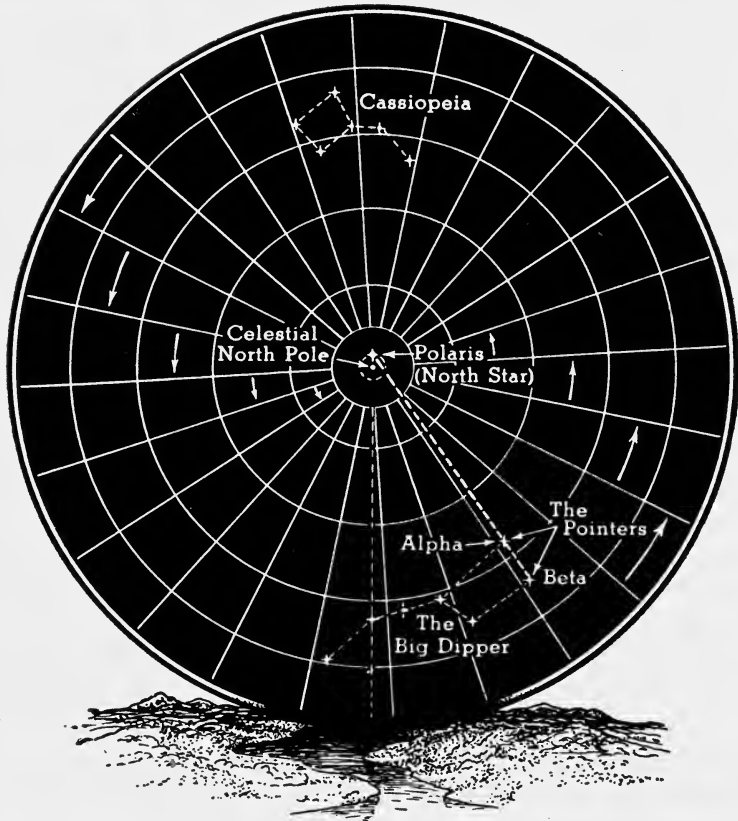

FIG. 220. Rotation of the Heavens about Polaris

Polaris may be found in the sky, at night, by following the *pointers*, alpha and beta, of the Dipper. It is almost on a straight line with the *pointers*.

★236. **Latitude determined by day.** Another method of finding the latitude of a place is to measure, with the sextant, the elevation of the *midday* sun above the

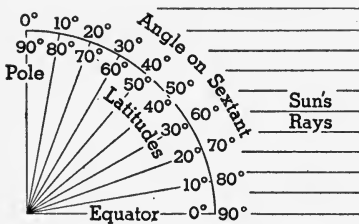

FIG. 221. Finding Latitude by the Sextant

horizon. The complement of this angle is the latitude of the place (Fig. 221). At the time of the equinoxes the sun is directly on the equator, and the sextant angle would be 90°. For other times the latitude is found in a table in the Nautical Almanac which gives the sun's declination for any time of the year.

All we need to do is to read the sextant, look up in the Almanac the date and the sextant angle, and we shall find the corresponding latitude.

**237. Longitude.** To locate the east and west position of a place, circles are drawn through the poles all the way round the earth. These circles are called *meridians* (Fig. 222). They are farthest apart at the equator, where the distance between meridians is about 70 miles ( $25000 \div 360$ ). At the poles the distance is zero. At latitude 40°, near New York City, the degree of longitude, which is  $\frac{1}{360}$  of the parallel of latitude, is a little over 50 miles.

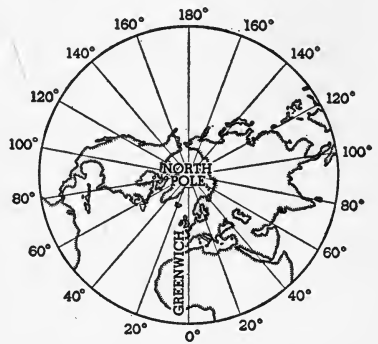

FIG. 222. Meridians of Longitude

Where shall we start 0° longitude? There is no line like the equator and we have had to fix arbitrarily some point through which the 0° or *prime meridian* shall pass. This point is fixed at the Royal Observatory at Greenwich, near London, England. All points east of that are said to have east longitude, and points west to have west longitude, the maximum being 180° in either direction.

The location of any place on the earth's surface is given in latitude and longitude. For example,  $40^{\circ}$  N and  $75^{\circ}$  W would mean that the place was on the parallel  $40^{\circ}$  north of the equator, at the point where the meridian  $75^{\circ}$  west of Greenwich crosses it.

**238. How longitude is determined.** The sun apparently circles the earth from east to west in 24 hours, passing over all the 360 degrees of longitude. In one hour, therefore, it crosses 15 degrees toward the west. If it is 12 o'clock at Greenwich it will be 11 o'clock at every place whose longitude is  $15^{\circ}$  W.

To find the longitude of a place, we must know the time at Greenwich as well as the local time. Accurate time is broadcast by radio from many stations throughout the world. From this information, Greenwich time can be found.

Before the days of radio every vessel carried several marine chronometers, or accurate clocks, set at Greenwich time. An observation on the sun gives local time, since the sun crosses the meridian at 12.00 noon. This will be when the sun crosses the north-south line, or when it is at maximum elevation in the sky. If local time is one hour earlier than Greenwich time, the place is at  $15^{\circ}$  W longitude.

**239. How to find a north-south line.**

1. An observation on Polaris any clear night will give the true north.

2. The gyro-compass points true north.

3. The magnetic needle, when corrected for declination, will give true north; but the declination varies so much that this is by no means accurate.

4. A rough way to find the north-south line is to find the direction of the shortest shadow cast by a vertical rod on a horizontal surface.

When the sun is at its highest point in the sky, shadows are shortest, and that will be at noon, when the sun crosses the meridian, which is a north-south line.

★240. **Navigation.** Finding the position of a ship on the open sea by observing the sun by day or the stars by night is called *navigation by observation*. When this cannot be done because of poor visibility, one of several other methods must be used.

1. *Dead reckoning.* By keeping account of the course at sea and the distance traveled, the officers can chart the vessel's position on a map.

2. *Radio position finder.* The apparatus on the vessel measures the bearing of any transmitting station or requests a known station to send signals. Knowing the positions of two sending stations and the directions from which signals are being received, the position of the ship can be charted by the intersection of the two direction lines.

3. *Echo sounding.* The *fathometer*, an echo sounding instrument, enables the skipper of a vessel to find the depth of water the ship is passing over by the time it takes for the sound of a whistle to go to the bottom, be reflected, and be received by a microphone under the ship. This instrument can also be made to draw the profile of the bottom on a strip of paper.

The Hydrographic Survey has charted the profiles of the bottom of the North Atlantic and is charting other important ocean lanes. If a skipper has the charts prepared by the Survey together with a fathometer, he need only get a profile of the ocean floor and compare it with the charts, to discover his position. This can be done night or day, in fair or foul weather.

241. **How time is determined.** We have determined longitude by means of Greenwich time and it is obvious that we can find the time by knowing the longitude. It is noon at any particular place when the sun crosses the meridian. At that same instant it is 1 o'clock P.M. at a point  $15^\circ$  of longitude east of the place and 11 o'clock A.M.  $15^\circ$  west. The time at a place, as determined by observation, is called *local time* or *sun time*. The apparent motion of the sun is faster, when nearer the earth, than when it is farther away. Since our solar days are not uniform, we take the average length of all the days in the year and call it

the *mean solar day*. Clocks are regulated to keep mean solar time, whereas from a sundial the actual solar time can be read.

**242. Standard time.** If all clocks were to read mean solar time, we should find a different *local time* at every place to which we traveled, east or west. This made little difference until the development of railroads brought confusion and the American railways, in 1883, adopted a system of *standard time*. Its advantage is that neighboring places keep the same time, instead of differing a few minutes or seconds according to their longitude.

The standard time belts are about  $15^{\circ}$  in width, and every point within the belt has the same or standard time. These zones are shown in Fig. 224. This system of standard time has spread over the entire world.

As one travels west, all watches are set back one hour on entering each new standard time belt — three times from the Atlantic coast to the Pacific.

**243. Daylight-saving time.** In summer the days become longer than in winter and especially in the higher latitudes of northern United States. In order to take advantage of the sunlight, for health, and to save electricity used for lighting, it is customary in many cities to advance the clock one hour in spring. A person who ordinarily rises at 7.00 A.M. will, under daylight saving, rise at 6.00 A.M., standard time, but his clock reads 7.00 A.M. In the evening, if his work is over at 5.00 P.M., it will really be 4.00 P.M., standard time, with the sun still high in the sky. People can enjoy several hours of outdoor activity in the sunshine and improve their health. Factories that use artificial light might save an extra hour of electrical energy. In the autumn,

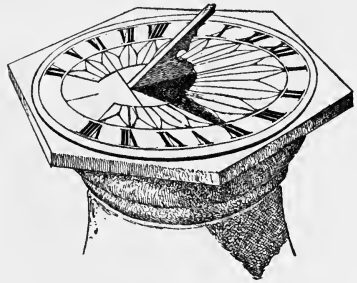

FIG. 223. Sundial

when the days get shorter again, there is no daylight saving, since it is dark at 7.00 A.M. as well as at 6.00 A.M. At that time the clock is set back on standard time.

**244. The civil day.** Our ordinary day, called *the civil day*, begins at midnight and ends on the following midnight.

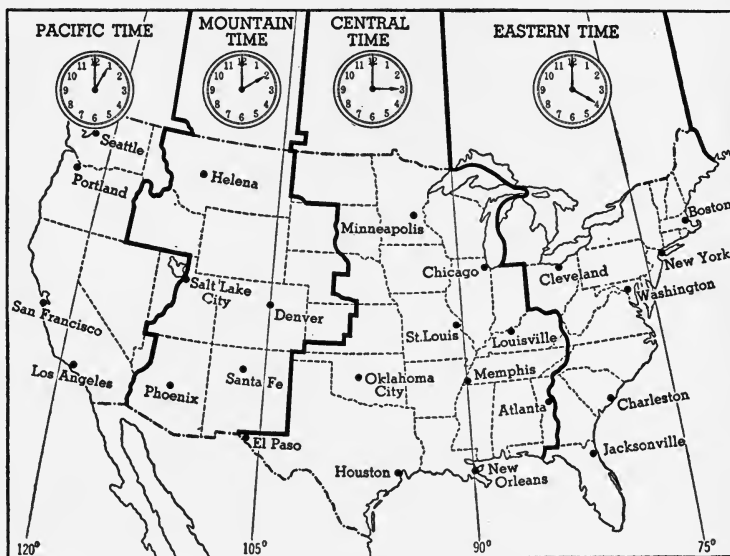

FIG. 224. Standard Time Zones of the United States

Business is generally suspended at midnight, and the change of date can be made then with the least confusion. The first 12 hours are called A.M., *ante meridian*, and the second period of 12 hours is called P.M., *post meridian*; 12 M., means noon, or sun on the meridian.

If a person travels westward around the earth, in the same direction as the sun, then for each 15° of longitude he travels westward he gains an hour, since he must set back his watch by one hour. If that person travels westward all around the earth, he will gain 24 hours; and having set back his watch 24 hours, his day of the week and his date are *one full day behind* what they would be if he had stayed at home. In going eastward this confusion is reversed.



Suppose an airplane were capable of traveling as fast as the sun and let us assume it starts westward at noon on Tuesday, April 15, from New York. Keeping up with the sun, it remains noon April 15 all the way and it arrives back in New York on Tuesday noon, April 15. Meanwhile 24 hours have elapsed and the people in New York are calling it noon of Wednesday, April 16. It seems that the aviator has *lost a day*.

If he had flown east, he would have gained a day, arriving in New York on Thursday, April 17, whereas it is only Wednesday, April 16.

In traveling around the earth westward, then, not only must one's watch be set back one hour for each standard time zone, but his day of the week and his date must be set ahead one full day. But where shall this change of date be made?

To avoid confusion, it has been agreed to make the change of date at the 180th meridian, called the *international date line*, somewhere in the middle of the Pacific Ocean (Fig. 225). Since the 180th meridian crosses several

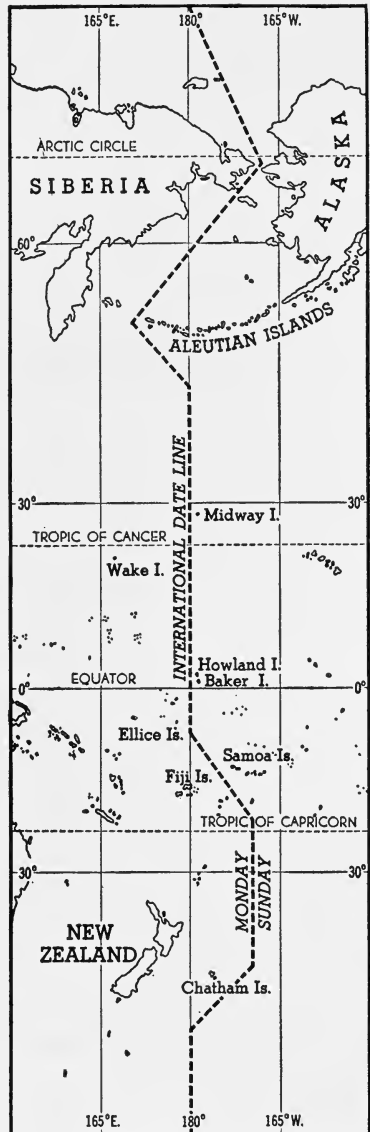

FIG. 225. The International Date Line

Since the 180th meridian crosses several

islands and land areas, notably New Zealand, the date line is shifted so as not to pass through these places. In that way no one has to worry about change of date except travelers, to whom it does not make any difference.

If for example, a traveler going from San Francisco to Japan reached the international date line on Sunday morning, July 16, the day west of the line would be called Monday, July 17; and vice versa, if he were going from Japan to San Francisco, and arrived at the international date line on Sunday, July 16, it would become Saturday, July 15, east of the line.

**245. The conventional day.** By international agreement the current day is called the *conventional day*. It begins at the international date line and moves westward  $15^\circ$  an hour with the sun. In other words, at some places on the earth the conventional day may be Wednesday, July 11, while at other places it is Thursday, July 12.

**★246. The calendar.** The calendar worked out by the Romans was based largely on the motions of the moon. As the yearly number of the revolutions of the moon varies, the Roman seasons and festivals did not keep in place and the calendar fell into a state of great confusion. For example, spring festivals would be celebrated in the winter, if it were not that every so often days were added to the calendar.

The word calendar is derived from the Latin word *Calendae* or "callings," because when the officials in charge saw the new moon, which was to begin the month, announcements or callings would be made from the Capitol regarding the month's calendar.

The Roman year consisted of 12 months, March being the first, and December the tenth. February had 28 days, there were four months of 31 days each, and the rest had 29 days.

**★247. The Julian calendar.** In 46 B.C. Julius Caesar, with the advice of Egyptian astronomers, reformed the Roman calendar. He made three consecutive years of 365 days each and the fourth of 366 days. The extra day was added to February. The length of the Julian year was 365.25 days; and since the true year has 365.24 days, the Julian year was 0.01 day or 11.2 minutes too long.

This amounts to a little more than 3 days in 400 years. As a consequence, the date of the vernal equinox came continually earlier; and in 1582 the *vernal equinox occurred on March 11*.

★248. **The Gregorian calendar.** In 1582 Pope Gregory XIII directed that ten days be stricken from the calendar, so that the spring equinox might occur on March 21. A further reform was introduced at this time in order to prevent a recurrence of the discrepancy. The Pope decreed that the centurial year should be counted as a leap year only when divisible by 400. Thus 1800, 2100, and so forth are not leap years; but 1600, 2000, and 2400 are leap years. The Gregorian calendar is now used in all civilized countries.

In England it was adopted in 1752. Dates and events which had occurred before the Gregorian calendar was adopted are termed *Old Style* (O.S.), and those after the adoption *New Style* (N.S.).

### *Completion Summary*

Parallels of latitude are circles ——— equator. There are ——— of them, equally spaced from ——— pole. The equator is at ——— degrees of latitude, while ——— 90° latitude. In one degree there are ——— minutes and in one minute ——— seconds of latitude. In miles, a degree is about ——— and a minute is a little more than ——— mile.

Latitude may be found at night by measuring the angle of ——— above the ———.

★By day, the latitude is equal to the complement of ———.

Longitude is determined by reference to ———. The prime meridian, through ——— is called 0°. There are ——— meridians, all passing through ———. To determine the longitude, it is necessary to know ———.

True north may be determined by ——— star, the ——— compass, or by finding ——— shadow ———.

★To locate a ship's position at sea, an observation on the sun or ——— may be made, or if these cannot be seen, mariners use ———, ———, or ———.

It is noon at any place when ——— meridian.

Standard time belts avoid the confusion of ———. When daylight-saving time is used, clocks are ——— in the spring and ——— in the autumn.

The civil day is the time between ———.

The international date line passes through the ——— meridian, except where that meridian ———. In traveling westward, the date is ——— at this line.

★The old Roman calendar was based on the ———. Confusion resulted because ——— months in the year is not a ——— number. The Julian calendar was based entirely on the sun, the number of months being fixed at twelve, because there are about twelve ——— in a year. The discrepancy in this calendar is only ——— days in ——— years. This discrepancy was practically eliminated in the Gregorian calendar, by introducing ——— years.

### *Exercises*

1. What are parallels of latitude?
2. How many miles are there in one degree of latitude?
3. How can true north be found at night?
4. Explain how to find the latitude of a place by an observation on Polaris.
5. How is latitude determined from the sun?
6. What are meridians of longitude?
7. What is one degree of longitude at the equator, in miles?
8. Why does the degree of longitude get shorter as we go away from the equator?
9. Where is the prime meridian? Why?
10. How can the longitude of a place be found?
11. When is it noon at a given place?
12. When it is noon at a certain place, it is 5.00 P.M. at Greenwich. What is the longitude of this place?
13. How can a north-south line be found by means of shadows?
14. How can the time be determined if the longitude is known?
15. What is "mean solar time"?
16. What is standard time? Why is it necessary?
17. How many standard time belts are there in the United States? Name at least one large city in each time belt.

18. Explain the advantage of daylight-saving time.
19. Explain the need for an international date line.
20. If it is Thursday just east of the international date line, what day is it west of the line?
21. When it is noon at New York, what time is it at Chicago? at San Francisco? at London?
22. What is meant by the conventional day?

*★Optional Exercises*

23. Explain why the gyro-compass points true north.
24. Explain how to determine the position of a ship by dead reckoning.
25. Explain the use of the radio position finder.
26. How can the fathometer be used to find the position of a ship?
27. Explain the difficulties with the Roman calendar.
28. How did the Julian calendar remedy the defects of the old Roman calendar?
29. Explain how the Gregorian calendar met most of the discrepancies of the old calendar.
30. What is meant by O.S. and N.S.?

## CHAPTER XXI

### THE MOON

**249. Distance and size.** The moon's average distance from the earth is about 240,000 miles. The actual distance during a single month varies about 30,000 miles, causing a corresponding variation in its apparent size.

The diameter of the moon is 2,163 miles or about one quarter of the earth's diameter. The earth has about 50 times the volume of the moon.

**250. Motion of the moon.** The *apparent* motion of the moon and stars, by night, and the sun, by day, is due to the earth's rotation from west to east. There is a *real* eastward motion of the moon, as may be seen by noting from night to night the position of the moon among the stars.

★Since the moon makes one complete revolution about the earth in  $27\frac{1}{3}$  days, the eastward motion is about  $13^\circ$  a day ( $360^\circ \div 27$ ); and as the sun also appears to move eastward among the stars about  $1^\circ$  a day, the eastward daily gain of the moon is about  $12^\circ$ . That is to say, the moon rises about 50 minutes later each day ( $12 \div 360 \times 24$  hours).

★**251. The moon has no atmosphere.** The absence of an atmosphere is shown by the fact that when the moon hides a star, the star disappears *suddenly* and not gradually, as it would if its light passed through an atmosphere.

There seem to be no effects of erosion on the moon, which also goes to show that there is no atmosphere. If the moon ever had an atmosphere at any stage of its development, it has lost it.

Neither is there any water, for if there were, it would evaporate during the long hot day and form an atmosphere of cloud and vapor.

★**252. Surface of the moon.** Moonlight is but reflected sunlight. The surface markings of the moon are known to be due to uneven-

ness. The visible surface has an area about the size of South America and nearly one half of this is covered with dark gray patches which were once supposed to be seas. The rest of the surface consists of mountains, so-called volcanoes, craters, and ringed valleys (Fig. 226). Some of the mountain chains have peaks nearly four miles high.



FIG. 226. The Moon's Surface

**253.** Same face is always toward the earth. Since the same side of the moon is always turned toward the earth, it follows that the period of rotation of the moon on its axis and its period of revolution about the earth are the same, about  $27\frac{1}{3}$  days; but owing to an apparent oscillation, we see, throughout the month, about six tenths of the lunar surface.

We know nothing, therefore, about the other four tenths of the surface of the moon.

The side of the moon that is toward the sun is always brightly illuminated, and the side turned away from the sun is in darkness. As the moon makes its way eastward around the earth, different portions of the illuminated surface are seen. This causes the *phases of the moon*.

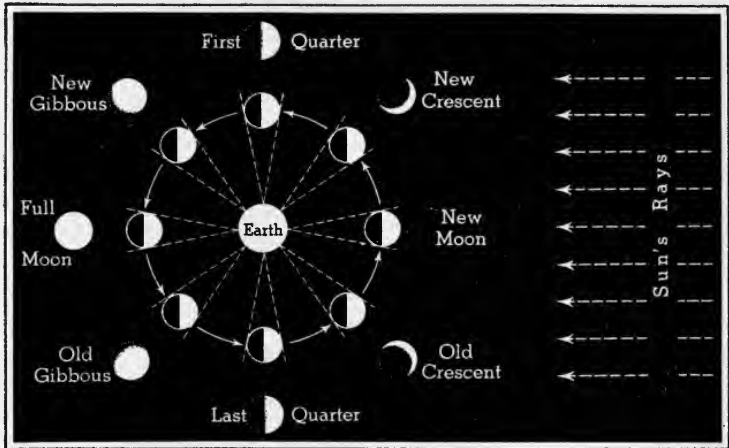

FIG. 227. The Phases of the Moon

The same half of the moon is always illuminated by the sun, but we on the earth can see only the part of this illuminated surface between the dotted lines. These parts, shown next to each position, are called the phases of the moon.

**254. New moon.** When the moon and the sun are on the same side of the earth, the dark side of the moon is turned toward the earth, and we have *new moon* (Fig. 227). New moon occurs, strictly speaking, when none of the bright surface is visible. Popularly, the moon is said to be new when seen as a very thin crescent. A day or two later, when the moon has moved a little eastward of the sun, we may see in the early evening, in the western sky, a small portion of the illuminated half in the form of a *crescent*, convex westward, or toward the sun, with the horns turned eastward, or away from the sun.



**255. First quarter.** A week after new moon, half of the illuminated hemisphere may be seen. The moon has now reached *first quarter*, and its shape is that of a half circle convex to the right. A line connecting it with the earth is at right angles to a line connecting the sun and the earth.

As the moon passes beyond the first quarter, the boundary line between the light and the dark area begins to be convex eastward and the illuminated portion continues to grow larger.

**256. Full moon.** When the moon and the sun are on opposite sides of the earth, the whole lighted half of the moon is turned toward the earth, and we have *full moon*, about a week after the first quarter. The line dividing the light and the dark areas, after full moon, changes from the left side to the right side of the moon's disk.

**257. Third quarter.** The moon reaches the last or *third quarter* about a week after full moon. In this phase the half circle is convex toward the left. After third quarter, the moon being west of the sun, the crescent curves to the left or toward the sun, and the horns point to the right, away from the sun.

**258. Waxing and waning.** In its revolution from new to full moon, the visible illuminated area increases and the moon is said to *wax*.

From full to new moon, the illuminated area decreases and the moon is said to *wane*.

**259. Earthshine.** The dark portion of the moon is sometimes lighted by sunlight reflected from the earth, called *earthshine*. This occurs at the young and old crescent phases, and makes the entire disk of the moon faintly visible.

**260. Eclipses.** All the planets and their satellites are opaque bodies and cast long, cone-shaped shadows, away from the sun (Fig. 228). The moon is eclipsed when it passes into the earth's shadow. The sun is eclipsed when the moon passes between it and the earth. During a lunar eclipse the moon is really darkened, light from the sun

being cut off by the earth. During a solar eclipse the sun is only apparently darkened; the moon cuts off light that would otherwise reach the earth. In reality it is the earth, rather than the sun, that is eclipsed.

**261. Lunar eclipses.** In Fig. 228 the moon is passing through the earth's shadow and is totally eclipsed. The

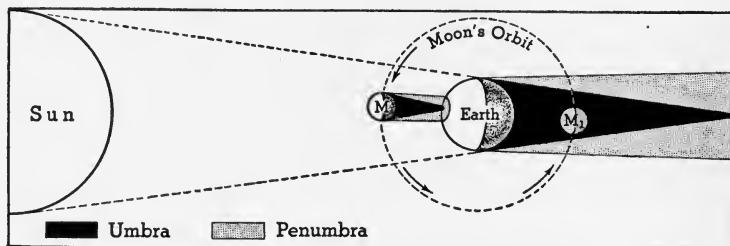

FIG. 228. Eclipses of the Sun and Moon

moon's disk is usually visible at this time, because of sunlight refracted into the earth's shadow by our atmosphere. This gives to the moon, during a total eclipse, a dull, copper-colored appearance.

When the moon passes slightly above or below the center of the earth's shadow, and only a part of the moon's disk enters the shadow, a partial lunar eclipse occurs.

The moon in its monthly revolution about the earth usually escapes the earth's shadow entirely and it is therefore not eclipsed.

**262. Solar eclipse.** The moon, being an opaque body, casts a shadow; and when the moon is between the sun and the earth, this shadow may be long enough to reach the earth and cause a total solar eclipse for those who are in the path of the shadow (Fig. 228). For an observer so located, the moon appears to move across the face of the sun and to cut off the light from the sun (Fig. 229).

The eclipse begins when the black body of the moon appears to cut a notch from the edge of the sun. As the moon moves over its face, the sun appears as a diminishing cres-

cent; and as the moon moves off, an increasing crescent is seen with the horns turned in the opposite direction.

Near the beginning of totality, the pearly white halo of the *corona* of the sun flashes out and this is visible during totality, which is never more than about eight minutes. The time of the entire eclipse is about one hour.



FIG. 229. Solar Eclipse  
The moon is moving to the right.

Should any of the brighter planets happen to be near the sun during totality, they can generally be recognized because the sky is almost as dark as night. Usually a few of the brightest stars also appear.

Several streamers of light, equal in length to the diameter of the sun, and longer, may be seen extending out from the corona. Near the sun, red flames known as prominences appear. As the path of the moon's shadow on the earth is always less than 170 miles wide, it is an event of a lifetime for a person to see a total eclipse of the sun without making a journey to distant places.

In consequence of the eastward motion of the moon about the earth, the shadow moves eastward and with great velocity.

The total eclipse of the sun is of much scientific interest to astronomers, because it enables them by means of the spectroscope to discover new elements in the sun's corona, because they can then obtain more accurate data concerning the moon's motion, and can study light and shadow phenomena.

An observer in the penumbra (the outer part of the shadow from which the light is not entirely cut off) of the moon's shadow would see only a part of the sun's disk. That is called a *partial eclipse*.

★ Sometimes the moon's shadow is not long enough to reach the earth, and the moon passes centrally across the sun's face, leaving a ring of the sun exposed. Such an eclipse is said to be *annular*. The moon appears as a black spot covering the central portion of the sun's disk, surrounded by a ring of light.

★ **263. Number of eclipses in a year.** There are always at least two eclipses of the sun in a year, and there may be as many as four. The largest number of lunar eclipses in a year is three. As every eclipse of the moon is visible at one time from all points on half the earth, and eclipses of the sun can be seen from a narrow area only, many more lunar eclipses are visible at a given place. London during twelve centuries was privileged to see only two total eclipses of the sun.

### *Completion Summary*

We always see ——— moon, because the moon revolves ——— in the same time it takes to ——— on its axis.

When both moon and ——— are on the same side of the earth, we have ———. A week afterward, when half of the surface of the moon turned toward us is ———, we have ———. The illuminated surface increases in area until fully ——— of the moon is seen. This phase is called ———. From then on, less and less of the moon is seen each night, until we get ———. The moon is said to wax and wane as the illuminated portion ———.

An eclipse of the moon is caused when the earth ——— sun. An eclipse of the sun ——— moon ——— sun. When the moon hides only part of the sun, the sun is said to be in ———.

### *Exercises*

1. What is the approximate distance of the moon from the earth? How many times as far away is the sun?

2. What is the approximate diameter of the moon?
3. Why does the moon seem to be moving toward the west?
4. What is the period of revolution of the moon?
5. Why do we always see the same side of the moon?
6. What is meant by the new moon? How long is it visible?
7. What is meant by first quarter?
8. What conditions account for the full moon?
9. What are the phases of the moon?
10. What is meant by third quarter?
11. What is the meaning of the expression "the moon waxes and wanes"?
12. Account for earthshine.
13. What causes a solar eclipse? Why can it not be seen all over the earth?
14. What is meant by a partial eclipse of the sun?

#### ★*Optional Exercises*

15. Explain why the moon rises 50 minutes later each day.
16. What evidence convinces us that the moon has no atmosphere?
17. Explain the difference between a phase of the moon and a lunar eclipse.
18. What is an annular eclipse?
19. Why are more total eclipses of the moon than of the sun seen at any place?
20. The time from full moon to full moon, called a lunar month, is 29.5 days, while the actual time of revolution of the moon about the earth is 27.3 days. To what is this difference due?

## CHAPTER XXII

### THE SOLAR SYSTEM

**264. Solar system defined.** The sun together with the bodies revolving about it is called the *solar system*. The members of the solar system are the sun, the planets and their satellites, some comets, and meteors.

The sun, near the center of the system, is a very large, hot, luminous body, giving heat and light to the other members of the solar system. Its gravitational attraction controls their motions.

The planets, nine in number, upon one of which we live, revolve about the sun in elliptic orbits, in different periods of time, and at different distances from the sun (Fig. 1).

Planets are distinguished from stars by their changing position among the stars, and by their visible disk when seen through a telescope. Stars seem to twinkle; planets do not.

Stars keep their relative position in the sky and through a telescope appear as points of light. The following table gives some information about the planets which is meant to be merely comparative and should not be memorized.

PLANETS	DIAMETER IN MILES	AVERAGE DISTANCE FROM SUN IN MILLIONS OF MILES	PERIOD OF REVOLUTION IN YEARS	NUMBER OF SATELLITES OR MOONS
Mercury	2,700	36	0.24	0
Venus	7,800	67	0.62	0
Earth	7,913	93	1.00	1
Mars	4,300	141	1.88	2
Jupiter	87,000	483	12.00	9
Saturn	72,000	886	29.00	10
Uranus	35,000	1,782	84.00	4
Neptune	32,000	2,792	165.00	1
Pluto	Small	3,845	300.00	..

Reliable information about Pluto, the furthestmost and probably the smallest of the planets, is not yet available.

All except two of the planets have satellites revolving about them. The satellites are very unevenly distributed among six of the planets as seen in the table. Our moon is a satellite.

★The *planetoids* (planetlike bodies), about a thousand in number, are small bodies, the largest being about 500 miles in diameter, that revolve about the sun between the orbits of Mars and Jupiter. The planets between the planetoids and the sun are much denser than the others.

*Comets* are bodies that are temporarily visible, of large dimensions and small mass, unstable in form, usually with long tails and with uncertain orbits. They are believed to be entirely gaseous.



FIG. 230. A Comet

Some comets revolve about the sun in closed orbits, have fairly definite periods of revolution, and are consequently members of the solar system (Fig. 230). Other comets, with open orbits, enter and leave our solar system without seeming to be members of it.

Meteors are comparatively small masses of stone or metal (Fig. 231) that enter the earth's atmosphere from space, and, as they do so, they glow because they get hot from the friction of the atmosphere. Millions of meteors fall on the earth and those which become visible are called *shooting stars*.

★265. **Size of the solar system.** An idea of the size of the solar system may perhaps be gained from Sir Wm. Herschel's apt illustration:

Choose any well-leveled field. On it place a globe two feet in diameter. This will represent the sun. Mercury will be represented

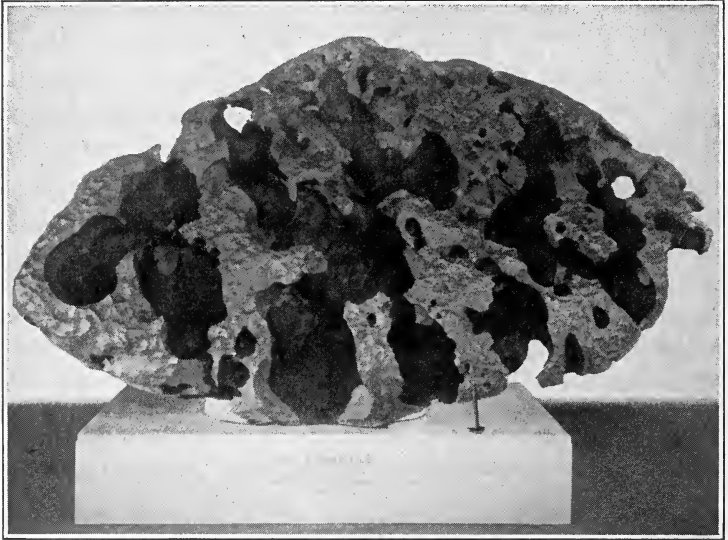

FIG. 231. A Meteor

The hammer shows the comparative size of the meteor.

by a grain of mustard seed on the circumference of a circle 164 feet in diameter, for its orbit; Venus, a pea, on a circle of 284 feet in diameter; the earth, also a pea on a circle of 430 feet; Mars, a rather large pin's head on a circle 654 feet; the asteroids, grains of sand in orbits 1,000 to 2,000 feet; Jupiter, a moderate-sized orange in a circle of nearly half a mile across; Saturn, a small orange on a circle of four fifths of a mile; Uranus, a full-sized cherry or a small plum upon the circumference of a circle more than a mile and a half; and finally Neptune, a good-sized plum, on a circle about two miles and a half in diameter.

**266. Space outside the solar system.** When we look about us in space we find we are rather isolated, the nearest star being 25 *million million* miles away. The stars, which are very numerous, are suns like ours, but whether each one is the center of a system of planets like ours we do not know; but modern astronomers are inclined to believe that our solar system is a freak and does not often occur in the universe. When speaking of the stars we usually refer to



those found in the Milky Way, the *galaxy* to which we belong. It has been estimated that there are about 3,000 million stars in our own galactic system.

The *spiral nebulae* (Fig. 232) are believed to be galaxies like ours. In fact, stars can be seen in some of them.



FIG. 232. Spiral Nebula

The nearest galaxy to ours is one million *light years* distant. Light travels 186,000 miles per second. How far would it travel in a year? That distance is a *light year*. It is about six million million miles. Hence the nearest galaxy is a million times as far as that.

**267. The sun.** Our sun is a rather small star; Antares has a diameter 400 times that of the sun. But the sun is the largest body near us. It has a diameter of 864,000 miles,

about 100 times that of the earth, and it has about one quarter the density of the earth.

The visible surface of the sun is called the *photosphere*. It is cloudlike in appearance and gives forth most of the light and heat which the sun radiates.

**268. Elements in the sun.** By means of an instrument called the spectroscope it is possible to analyze the sun,

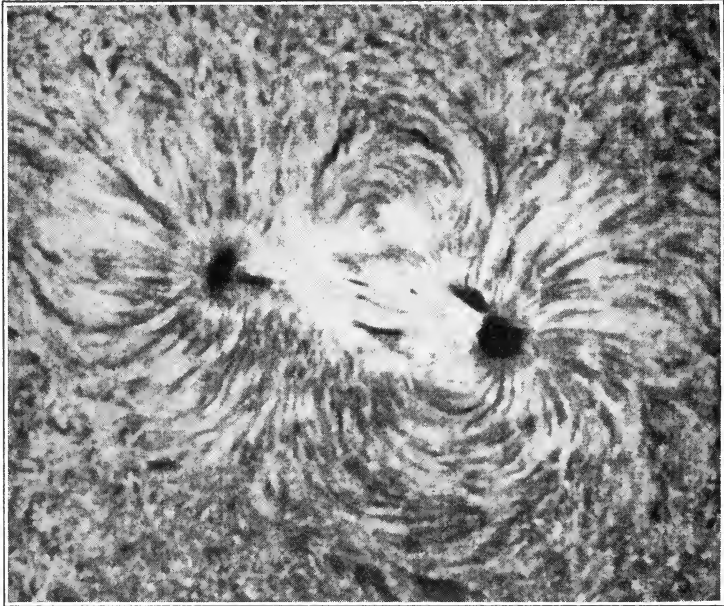

*Photograph by Mt. Wilson Observatory*

FIG. 233. Sunspots

and we find that the same elements which make up the earth, oxygen, hydrogen, carbon, iron, and others, also make up the sun; 66 of them appear in the sun's atmosphere.

★**269. Sunspots.** Dark spots of irregular outline, called *sunspots*, often many thousands of miles in diameter, mar at times the brightness of the photosphere (Fig. 233). These sunspots are believed to be connected with the hidden circulation in the great body of the sun below the photosphere, and are dark only by comparison with it.

Observers of sunspots soon found that the sun turns on its axis from west to east.

The earth's magnetism is disturbed during a period of sunspot activity. A large number of sunspots appear and a greater development of solar prominences occurs most frequently at these times. The period of maximum disturbance occurs on an average about every 11 years.

As the sun rotates on its axis in about 26 days, no spot would remain continuously visible for more than 13 days or half the period of rotation. Some spots last, however, only a few days; others persist for months. They are now believed to be solar storms of great violence.

★270. **The chromosphere.** Outside the photosphere is a deep envelope of gas, mostly hydrogen and helium, called the *chromosphere* or color sphere. Portions of the hydrogen are thrown up in huge tongue-like flames, called *prominences*.

When the moon comes between the earth and the sun, the light from the photosphere is cut off and the sun is said to be eclipsed. During a solar eclipse the chromosphere can be seen as a brilliant scarlet ring, with the prominences shooting out thousands of miles.

★271. **The corona.** The outermost portion of the sun is the *corona* (crown), a halo of pearly light extending out many thousands of miles, with streamers reaching out millions of miles. (See frontispiece.) It is believed that the light of the corona is due to the reflection from dust particles, liquid globules, and small masses of gas.

★272. **The sun's heat.** The temperature of the sun near its surface is at least 10,000° F. and it is radiating energy at such a rate that if the source of the heat were due to ordinary burning, even if the sun were made entirely of coal, oil, and other combustibles, it would have burned out in 5,000 years. But we have evidence that its temperature has not even diminished noticeably within geologic history. What then is the source of its heat? The latest theory, held by Eddington and Jeans, is that, in the sun, atomic disintegration and creation may be going on all the time. If simple atoms were to be built up into complex ones, a certain amount of the mass would be converted into energy and set free.

For example, if hydrogen were to be converted into helium,

4.032 pounds of hydrogen would yield 4.000 pounds of helium and 0.032 pounds would be transformed into energy. And so enormous would be the energy set free that if this change went on every second, it would be equivalent to the generation of 1,800 billion horsepower.

If that is what is going on in the sun, then its matter is being consumed, but at such a slow rate that it can continue to radiate, at its present rate, for 10 million million years.

★273. **Mercury.** So far as is known at present, Mercury is the smallest planet, the nearest to the sun, and the swiftest in its movements about the sun. It can be seen only in the direction of the sun, during early twilight or late dawn.

Mercury has a thin atmosphere, if any. It has surface markings of permanent streaks and a known rotation period equal in length to its year of 88 days. Since the periods of rotation and revolution are the same in length, *Mercury always turns the same side to the sun.* This side has perpetual daylight and summer, while the other side is always cold and in darkness.

274. **Venus.** Venus shines in the sky with peculiar brightness. It is only a little smaller than the earth. The period of rotation is 255 days and also equal to the period of revolution.

Mercury and Venus pass between the earth and the sun and therefore present all the phases similar to those of the moon. The passages are called *transits* and occur at irregular and relatively long intervals of time. During these passages Venus and Mercury look like small, round, black spots passing across the sun.

275. **The earth.** Although we know that the earth is a planet moving about the sun like the other planets, the earth seems to us to be the center about which other heavenly bodies move. The earth has the general form of the other planets, that of a spheroid. It is the third in distance from the sun, and the largest of the four smaller planets whose orbits lie within those of the planetoids. The earth makes  $365\frac{1}{4}$  rotations during one revolution.

276. **Mars.** Mars appears in the sky, shining with a steady, pale-red light. Though having only a little more than half the diameter, Mars resembles the earth in more re-

spects than any of the other planets. Its period of rotation is 24 hours 37 minutes, or a little more than our day. The inclination of its axis is about  $24^\circ$ , ours is  $23.5^\circ$ . Therefore, except for its greater distance from the sun, the days and change of seasons resemble those on the earth.

Surface markings on Mars indicate to some astronomers snow fields and canals. There seems to be little doubt about the white polar caps that appear and disappear according to the season. It is not certain however that they are fields of snow.

Although we have as yet no evidence for a positive statement concerning inhabitants on Mars, it may be said that, if any of the planets, other than earth, is inhabited, it is probably Mars.

★277. **Jupiter.** Jupiter is the largest of all the planets, and with the exception of Venus, often the brightest in the sky. Surface markings on Jupiter are described as parallel belts and spots. Because of the lack of permanency of the markings, they are thought to be due to a deep atmosphere surrounding the planet. From observations of the spots it has been found that Jupiter has a rotation period of about 10 hours, the shortest of any of the planets.

The circumference is about 11 times that of the earth. At its equator it is rotating about 30,000 miles an hour, about 30 times as fast as the earth.

The outer five planets, Jupiter, Saturn, Uranus, Neptune, and Pluto, are supposed to be of a higher temperature, of less density, and in not so advanced a stage of development as the other four planets.

278. **Saturn.** Saturn is distinguished from all other planets by three thin, flat, meteoric rings about 100 miles thick (easily visible through a small telescope), which surround it in the plane of its equator. The rings are together about 40,000 miles wide and the inner edge less than 6,000 miles from the planet (Fig. 234).

At distances ranging from 100,000 miles to nearly 8 million miles from Saturn, are 10 satellites, more than have yet been discovered belonging to any other planet of the solar system.

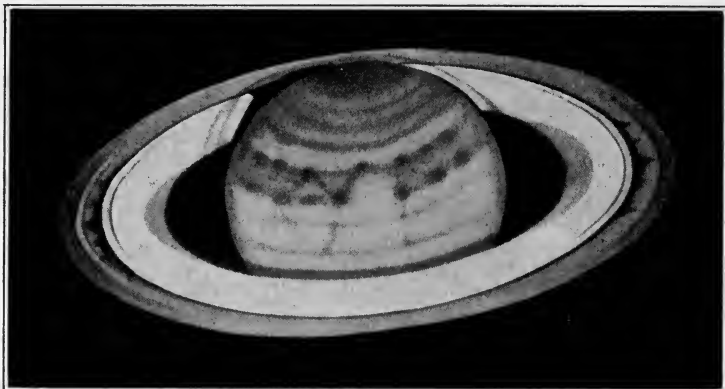

FIG. 234. Saturn

The surface markings on Saturn are not seen nearly so well as those on Jupiter, because Saturn is nearly twice as far from us. There are bright and dark belts, and at times faint spots.

Saturn rotates on its axis in about 10 hours. Because Saturn has a density less than water, it is believed to be largely in a vaporous condition. It may be seen shining in the sky with a steady yellowish light, with about the same degree of brightness as the brightest star.

★279. **Uranus, Neptune, and Pluto.** Uranus was discovered in 1781, Neptune in 1846, and Pluto in 1930. All the other planets were known to the ancients.

Uranus is a very faint object in the sky; Neptune and Pluto are invisible to the naked eye. Pluto has the longest period of revolution, equal to 300 earth years.

It may be inferred that the physical condition of these planets is much the same as that of Jupiter and Saturn. The rotation period of Uranus, as indicated by surface markings, is between 10 and 12 hours.

Since these planets are so far from the sun, they receive very little heat per unit area compared with the earth.

### 280. Characteristics of a planet.

1. The planets move in the same direction about the sun, from west to east. The sun rotates in the same direction, which, as viewed from above the North Pole of the earth, is counterclockwise.

2. The paths, or orbits, of all the planets are ellipses, with the sun at one of the foci.

3. The planets are nonluminous, like the earth; the light coming from them is reflected sunlight.

4. Most of the planets are known to rotate in the same direction as the earth, from west to east.

5. All the planets, as well as the sun, are composed of the same elements.

★281. **The satellites.** Previous to 1610 the only known satellite was our moon. In that year Galileo first pointed his telescope to the sky and saw four large moons of Jupiter.

Our moon is more than 2,000 miles in diameter, but not so large as three of the 8 moons of Jupiter and one of the 10 moons of Saturn. The largest satellite of Jupiter is 3,558 miles in diameter, considerably larger than the planet Mercury. The smallest satellites known are the two belonging to the planet Mars, both of which are probably less than 10 miles in diameter. One of the two is only 5,800 miles distant from Mars and makes a revolution in less than 8 hours, one third of the time it takes Mars to rotate.

The earth's satellite, the moon, is about 240,000 miles distant from the earth and makes a complete revolution in about  $27\frac{1}{3}$  days.

The most distant satellite of Saturn takes considerably more than an earth year to make one revolution.

Our moon is larger compared to the earth than any other satellite compared to its planet. Mercury and Venus have no satellites, Uranus has four, and Neptune one.

★282. **Planetoids.** The planetoids, sometimes called *asteroids*, move about the sun just as the planets do. They are so small that they are invisible to the naked eye. Jeffreys thinks that they may have originated from the explosion of a planet.

Not until the beginning of the nineteenth century were any of these bodies discovered, but a formula for the distances of the planets from the sun called for a planet between Mars and Jupiter. Long and careful search led to the discovery of Ceres, 485 miles in diameter. There are several whose diameters are more than 100 miles, but the majority are much smaller, ranging down to 10 miles in diameter. New ones are being found every year.

Over 1,300 planetoids have been found, all together having about one five hundredth the mass of the earth.

Each one has an orbit and an inclined axis like the planets.

★283. **Comets.** Comets are in strong contrast with planets in appearance and physical condition. Most of them enter the solar system with orbits in the form of open curves, make one turn about the sun, and pass away, probably forever.

Of the few comets that belong permanently to the solar system, all have definite periods of revolution about the sun, varying from 3.3 years (Encke's comet) to about 76 years (Halley's comet). Halley's comet last appeared during May, 1910.

The typical comet is largely self-luminous and is composed of a head and a tail. In the center of the head is a bright, starlike nucleus surrounded by faintly luminous matter, called the *coma*. The tail acts as your shadow does when you walk around a lamp. It always points away from the light. Some astronomers maintain that it is the pressure of sunlight that drives the gaseous particles from the nucleus, and thus forms the comet's tail.

The head may have a diameter greater than that of the sun, with a nucleus as large as the earth, and the tail equal in length to the distance of the earth from the sun. The amount of matter in a comet is very small, in most cases less than one millionth of that of the earth.

The orbits of the planets are slightly elliptical, and all are approximately in one plane; those of the comets are greatly elongated and lie in every possible position. With the unaided eye it is a rare sight to see a comet.

Halley's comet has been pursuing its fixed orbit about the sun since the dawn of history and undoubtedly long before. The accounts of many of its earlier appearances seem to indicate that it has often been a conspicuous object in the sky. The last appearance, during May, 1910, was disappointing. This tends to show that the great comet has for ages been slowly disintegrating.

Under the most favorable conditions the nucleus of Halley's comet was brighter than stars of the first magnitude, the coma was a faint light, and the tail was a band of light about  $8^\circ$  wide at its widest place and  $120^\circ$  long. Stars were plainly visible through the comet's tail. It is believed that the earth passed through the tail on May 18, 1910. At that time there were no unusual manifesta-



tions seen, such as the falling of an unusual number of meteors, a glow of the sky, or the appearance of deadly gases, all of which had been predicted.

★284. **Meteors.** The earth in its path about the sun encounters daily many millions of small bodies which enter its atmosphere from outside space. On a clear, moonless night, one may see several an hour. They often appear at altitudes of 100 miles, move many miles a second, give out light and heat, and are usually consumed before they reach the surface of the earth. These bodies are called *meteors*.

The appearance of a large number of meteors, usually in August and November, is known as a *meteoric shower*. Sometimes bodies weighing from a few pounds up to several tons fall to the earth's surface, unconsumed. Such bodies are known as *meteorites*. Some are composed of nearly pure iron, with a little nickel. Most meteorites are composed of stone, often with traces of iron in them. About thirty of the different elements found in the earth have been found in meteorites.

**285. Nebular hypothesis of Laplace.** Many hypotheses concerning the origin of the solar system have been proposed, but the one that has exercised the greatest influence upon thinking people of the past century is the *nebular hypothesis*, as formulated by Laplace. This hypothesis maintains:

1. That the matter of the solar system was once a highly heated mass of gas called a *nebula*.

2. That the form was a vast spheroid extending beyond the orbit of the farthest planet.

3. That the nebula was in process of cooling, and the cooling caused shrinkage. An effect of shrinkage was to increase the rate of rotation, and this increased the equatorial bulge.

4. That when the rotation increased to a certain speed, the centrifugal force at the equator of the spheroid equaled the attraction due to gravitation. Upon further cooling and contraction, the equatorial portion separated from the great rotating mass, forming a ring resembling the rings of Saturn.

5. That as the cooling and contraction of the spheroid continued, additional rings were separated. The first ring gave rise to the outermost planet, and the later ones to the other planets in turn.

6. That the central body was the sun.

7. That each ring parted at its weakest point as cooling caused contraction, and the matter was ultimately collected into a planet, which was hot and gaseous.

8. That the cooling of the planet caused further contraction, which in turn increased the rate of rotation and consequently the amount of bulging. Some of the planets followed the example of the parent nebula and formed rings which became satellites.

9. That as the cooling and shrinking went on, the gases changed to a liquid and then to a solid state. In the case of the earth, the volume decreased from a rotating mass of gas extending to the orbit of the moon, to its present size.

10. That the more volatile material of the earth remained in a gaseous state and formed our atmosphere, originally much deeper and of a higher temperature than now. As the atmosphere cooled, the water vapor condensed and formed clouds. As cooling continued, rain fell and the oceans formed.

**★286. How well does the nebular hypothesis explain the facts?**  
The nebular hypothesis explains the following facts rather well:

1. All the planets are composed of the same elements because they are all derived from a common nebula.

2. They revolve about the sun in the same plane, in the same direction, and in nearly circular orbits.

If they were split off from the sun as circular rings which were revolving with the sun, they would naturally continue to revolve on that same circle in the same direction and in the same plane, because by the law of inertia they would change only when acted on by an outside force, and there is none.

3. They are at different distances from the sun because, as each

ring was split off, the parent sun became smaller and the next ring was consequently smaller.

4. The sun is hot because it was originally hot.

5. The interior of the earth is hot because it was originally hotter and has cooled only on the surface.

6. The earth has an atmosphere, which is naturally what is left after all the other substances had cooled and changed to solids or liquids.

The nebular hypothesis does *not* explain the following facts satisfactorily:

1. The sun is rotating, but rather slowly.

According to the hypothesis it should be rotating rapidly.

2. The sun has no equatorial bulge.

Since the sun is still gaseous, at least on the outside, it should be showing a bulge at the equator from which a new ring is about to split off.

3. All satellites do not revolve in the same direction and in the same plane.

There are many more objections which need not be mentioned here, but they are so fundamental that it is evident that a solar system could never be evolved by such a process as that described in the nebular hypothesis.

**287. The planetesimal hypothesis.** In 1900 Chamberlin and Moulton, two American scientists, enunciated the planetesimal hypothesis, which attempted to overcome the objections to the nebular hypothesis.

The planetesimal hypothesis starts with a mass of hot gas, like the nebular hypothesis. A star of large magnitude passed near by, and, by gravitation, caused two tidal bulges, like the two high tides on the earth,  $180^\circ$  apart. The spiral nebula, thus formed, revolved as it was drawn out of its original position, and the star passed on its way, leaving the nebula, with two arms curved about the nucleus or sun, to cool rapidly (by *expansion*) into solid particles.

The formation of planets then took place as follows:

1. We started with a cold nebula, spiral in form, which is the most common type now seen.

2. The spiral nebula consisted of a central portion or nucleus, which became our sun, with two arms starting from opposite sides and curved spirally about the nucleus or center.

3. A significant feature of the spiral nebula was the presence of numerous nebulous knots in the arms. These knots were the denser portions of the nebula, and the nuclei of future planets and satellites.

4. The knots or nuclei were surrounded by a nebulous haze, which was composed not only of gaseous particles but also of innumerable solid or liquid particles. These particles revolved about the center of the nebula like little planets. They are called *planetesimals*. The nuclei grew and became planets and satellites by attracting other planetesimals. The earth and moon were two companion nuclei of unequal size.

5. The earth developed from a knot in the arm of a spiral nebula by the capture of outside planetesimals. The increasing gravitational compression of the interior produced the internal heat of the earth.

6. Gases were held in the solid planetesimals as they are held in meteorites that now fall to the earth. As the growing earth became heated by internal compression, the gases were given forth gradually, thus forming an atmosphere about the earth. Until the earth had attained a mass greater than that of the moon ( $\frac{1}{81}$  of the earth), its gravity was probably insufficient to enable it to hold the gases of an atmosphere such as we now know. The gases now issuing from volcanoes were occluded in the original planetesimals which formed the earth.

7. When the earth had reached such size that water vapor was held in the atmosphere in sufficient quantity to reach the saturation point, the water vapor began to condense, and rain fell on the earth. The water ran down from the higher to the lower places, where it collected and ultimately formed the oceans.

**288. The two hypotheses contrasted.**

## NEBULAR HYPOTHESIS

1. Nebula, hot and large, formed rings around central mass or sun.
2. Rings became planets.
3. Smaller rings separated from planets and became satellites.
4. Planets and satellites originally hot and large, gradually cooling and growing smaller.
5. Outermost planet, Pluto, formed first and others at later periods.
6. Earth always had an atmosphere.

## PLANETESIMAL HYPOTHESIS

1. Nebula, cold, formed two arms around central mass or sun.
2. Nuclei or knots became planets and satellites.
3. Smaller knots were captured by larger knots and became satellites.
4. Planets and satellites originally cold and small, gradually heating and growing larger.
5. Planets and satellites formed at same time.
6. Earth, when small, without an atmosphere.

**289. Objections to the planetesimal hypothesis.**

1. We have evidence that the earth has passed through a liquid condition, because of the arrangement of its mass into a dense core surrounded by less and less dense matter.

2. Some of the planets seem still to be gaseous and therefore hot.

3. If the earth were a small solid to begin with, and erosion started to take place at once, the products of the erosion of more than half the earth would produce much more sedimentary material than we have. There would be, for example, much more salt than there is. The salt in the oceans corresponds rather well with erosion of a thin crust.

There are many more objections, chiefly astronomical, and some of these have been overcome by the new tidal theory of Jeans and Jeffreys.

**290. Tidal disruption theory of Jeans and Jeffreys.**

1. We start, as in the planetesimal theory, with a tidal disruption of the hot gas by a passing star.

2. The passing of the star left our sun with two revolving arms or filaments of hot gas, like a spiral nebula.

3. The cooling of each filament broke it up into 5 masses which began to contract toward nuclei, forming 5 planets

from one filament and 5 from the other; but one of them, the planetoids, remained separate, having no definite nucleus.

4. The outer planets would be less dense than those nearer the sun, and this agrees with the facts.

5. Those nearer the sun would lose much of their outer, less dense material to the sun by attraction, making them denser. This also agrees with the facts.

6. The satellites were formed when the star ceased its attraction and the planets were snapped back by the attraction of the sun. As each one passed the sun, a tidal disruption occurred and formed satellites.

7. The gaseous planets and their satellites continued to revolve, as they did after the star passed away.

8. Gradual cooling formed liquids and finally solids, while gases remained outside as an atmosphere.

This theory seems to agree with more of the facts than either of the others.

### *Completion Summary*

The solar system consists of the sun and \_\_\_\_\_ which \_\_\_\_\_ about the sun in \_\_\_\_\_ orbits. Our sun is a luminous body like the \_\_\_\_\_. It is a member of the galaxy called \_\_\_\_\_. The nearest galaxy to ours is one million \_\_\_\_\_ distant.

The sun is composed \_\_\_\_\_ as the earth.

The surface \_\_\_\_\_ photosphere. Outside of that \_\_\_\_\_ chromosphere. The outermost portion or crown is called \_\_\_\_\_.

★The heat of the sun cannot be due to \_\_\_\_\_, or it would have \_\_\_\_\_ in 5,000 years. The latest theory accounts for the enormous heat as due to building up of complex from simple \_\_\_\_\_, with transformation of some of the mass into \_\_\_\_\_.

Many of the characteristics of the planets \_\_\_\_\_ a common origin.

A comet seems to have an orbit, but most of them ———. Halley's comet seems to have an orbit around ———.

★Meteors are ———, which enter the ———. The planetesimal hypothesis would call them ———.

The nebular hypothesis attempts to explain the origin of ———. It all started as a hot ———, extending from the sun out beyond the orbit of the planet ———. It cooled and ———, causing it to increase its rotation. Centrifugal force caused the central ——— to bulge, and finally to throw off a ———. Nine rings in all were thrown off, which formed ———.

The planetesimal hypothesis starts with ——— nebula. The passing of a star near by caused ———. These two arms broke up ———. The planetesimals collected about ——— to form ———. The planets continued to grow by ——— planetesimals.

The tidal disruption theory of Jeans and Jeffreys starts like ———, but instead of cold planetesimals, ———, the two arms or filaments of the nebula remained ———.

### *Exercises*

1. What is meant by the solar system?
2. Name the planets of the solar system.
3. What is the difference between a planet and a star?
4. What is a satellite?
5. What is a galaxy? What is our galaxy called?
6. What is a spiral nebula?
7. What is a light year?
8. How far away is the nearest neighboring galaxy?
9. About what is the diameter of the sun? the earth?
10. How does the composition of the sun compare with that of the earth?
11. What is the shape of a spheroid?
12. In what respects does Mars resemble the earth?
13. In what direction do all the planets revolve?
14. What is the shape of the orbit of each planet?

15. What is the direction of rotation of each planet?
16. How do the planets compare with each other in composition?
17. In what respects does the planetesimal hypothesis differ from the nebular hypothesis?
18. What are the main features of the tidal disruption theory of Jeans and Jeffreys?
19. Name one fact explained by the tidal disruption theory which could not be satisfactorily explained by either of the other theories.

**★Optional Exercises**

20. Where are the planetoids? What is supposed to be their origin?
21. What is a comet?
22. What is a meteor?
23. How do we determine what elements are present in the sun?
24. What are sunspots? How did they help us to discover the sun's rotation?
25. What is the photosphere? the chromosphere?
26. What is the corona?
27. Explain the source of the sun's enormous energy.
28. If the theory is correct, how long can the sun continue to radiate energy at its present rate?
29. Which planet has no change of season? Why?
30. Which of the planets show phases like the moon?
31. Which of the other planets is most likely to be inhabited? Why do we think so?
32. Which is the largest planet? What is its period of rotation?
33. What distinguishes Saturn from the other planets?
34. Which planet has the longest year?
35. Name a planetoid. How large is it?
36. In what ways do the planetoids resemble planets?
37. In what way does a comet differ from a planet? Name a comet.
38. How does the composition of a meteor compare with that of the earth?
39. State one fact not satisfactorily explained by the nebular hypothesis.



## CHAPTER XXIII

### PROPERTIES AND FUNCTIONS OF THE AIR

**291.** No part of his environment is of more immediate concern to man than the air he breathes. If it is pure, he is strong; vitiate it and he sickens. Withdraw it for but a few minutes and he dies.

No other part of his environment has had so great an influence in helping or retarding him in his struggle for existence, or in his effort to improve his condition. How he dresses, what he produces, and what he eats are matters chiefly of weather and climate. Too great heat and too great cold, both of which depend so much on the air, are alike deadening to his striving for better things.

The savages of equatorial Africa and the Eskimos of the frozen North are both low in the scale of civilization; the former, because the enervating climate kills ambition; the latter, because providing for his mere physical needs exhausts his energies and leaves no time or desire for the cultivation of higher things. Both must adapt themselves to their climatic environment; neither can change it.

The sun and the atmosphere are the chief factors in weather and climate.

The atmosphere is the outer or gaseous envelope of the earth. The air fills all mines, caves, and underground passages. As ground air, it penetrates the soil and, in solution, it is carried to the greatest depths of rivers, lakes, and seas.

**292. How high is the atmosphere?** We know from observations made by aviators and by means of trial balloons that the density of the air decreases with distance from the earth; that is, it is rarer, higher up. But how high does the atmosphere extend above the earth? At even two miles above

the earth breathing becomes difficult, and aviators who go higher are supplied with tanks of oxygen. The only direct evidence we have regarding the upper reaches of the atmosphere is based upon the glowing of meteors which fall on the earth. When they enter the earth's atmosphere, air friction finally makes them hot enough to glow, so that they can be seen; and by trigonometric methods, their height can be calculated. The highest observed was at about 200 miles.

But that is not to say that the atmosphere is only 200 miles high. For the meteors must travel far in the rarer atmosphere beyond 200 miles before they become red hot. And so we can say the atmosphere is *much more than 200 miles* high. Theoretically, it gets rarer and rarer and extends indefinitely out into space.

All we can say with assurance is that we live at the bottom of an ocean of air, which extends far beyond 200 miles and becomes less and less dense.

**293. Properties of air.** Pure air is an invisible mixture of gases; colorless, odorless, and tasteless; perfectly elastic and easily compressed. It is very mobile, and, like all matter, it has weight: about one twelfth of a pound per cubic foot. When cooled to a low temperature and compressed, air changes to a liquid.

Compressed air is used to run the drills in deep mines because it furnishes ventilation as well as power.

The inertia of the air causes resistance to motion, retarding the speed of the runner, the automobile, and the airplane. On the other hand, it makes possible the flight of birds and of aircraft.

Moving air produces pressure on surfaces, which is made use of in driving ships and windmills, and which has to be reckoned with in designing tall buildings.

The *buoyancy* of air aids in the distribution of seeds and the sailing of balloons. Just as a piece of wood rises in water because it weighs less than its own volume of water, so also

a balloon rises in air because it weighs *less than its own volume of air*; and it will continue to rise until it reaches a level where it weighs the *same* as its own volume of air.

**294. Composition of air.** The lower air is essentially a mixture of nitrogen, oxygen, carbon dioxide, water vapor, dust, and several rare gases, among which are argon, neon, and helium. The approximate percentages of the gases are practically the same everywhere, while the water vapor varies very much: from 0.2% up to 2.5%.

COMPOSITION OF DRY CLEAN AIR

	APPROXIMATE %
Nitrogen	78
Oxygen	21
Argon and other rare gases	1
Carbon dioxide	0.03

That the air is a uniform mixture is probably due to air movements; otherwise we should expect the carbon dioxide, which is densest, to settle down and form a layer over the earth, as it sometimes does in wells.

Carbon dioxide, since it is one of the gases expelled by volcanoes, is most abundant near active volcanoes. Being likewise a product of combustion and decomposition of organic matter, it is more abundant in cities than in the open country, and more abundant in winter than in summer. Its use by growing plants also decreases its summer percentage.

Water vapor, the most variable component of air and one of the most important, is more abundant over the sea than over the land. Warm air holds much more water vapor than cold air; and therefore equatorial air contains much more water vapor than polar air; air at sea level much more than higher up. When the air ascends it loses its moisture as clouds, rain, snow, etc., and above a few miles there is practically no moisture in the air.

Dust is of two kinds, organic and inorganic. Organic dust includes microscopic animals and plants, pollen, and fibers of cloth and wood. Inorganic dust consists chiefly of smoke

particles, powdered rock (soil or volcanic ash), and bits of metal. Dust is more abundant over the land than over the sea and is confined to the lower air. There is usually more dust in the city than in the country, and more in dry than in rainy weather. Dust storms frequently occur in the central regions of the United States during periods of drought.

Mountain health resorts are sought partly because of the greater dryness of the air and partly because of its freedom from dust and disease germs that constitute part of the air at lower levels. But the process of air-conditioning, which regulates the proper composition of the air, makes traveling unnecessary for that purpose alone.

The invigorating quality of air at sea and after a thunderstorm is due to ozone, a condensed form of oxygen. The percentage of ozone increases with altitude.

The composition of air changes materially as we rise. The dust and water vapor decrease rapidly above a few thousand feet and the oxygen increases slightly. Carbon dioxide decreases; and hydrogen, which at sea level is less than 0.01%, is supposed to rise to 95% at a height of 60 miles.

**295. Functions of the air.** Although the most important uses of the air are those of its individual components, yet the air as a whole has important functions. These are:

1. Its buoyancy helps birds and aircraft.
2. Sound is transmitted by air.
3. Ships and windmills are driven.
4. Seeds, pollen, microbes are carried.
5. Rain is distributed over land.
6. Waves and currents are produced in the sea.
7. Tornadoes and hurricanes are air in violent motion.
8. Wind erosion in arid regions
  - a. Wears down rock.
  - b. Carries away topsoil — dust storms.
  - c. Deposits dunes and loess.
9. Aids in cultivation of crops. (Soil without air is not fertile.)

**296. Functions of oxygen.** The oxygen of the air is the supporter of the chemical action called combustion. Things burn in air because they combine with oxygen. Oxygen also combines with substances without burning. This is *slow oxidation*. In the rusting of metals, oxygen combines with them, producing heat, but the heat is carried away so fast, by the metal, that the metal never gets hot enough to give out light. In the animal, oxygen is essential to life. It combines with carbon and hydrogen of the animal's tissues to produce heat.

The readiness with which oxygen unites with most other substances makes it active in promoting the disintegration of rocks and minerals. It is an important agent in the decomposition of dead animal and plant material.

Oxygen is slightly soluble in water; and it is this dissolved oxygen which is used by marine animals.

**297. Functions of carbon dioxide.** The carbon dioxide of the air, though of no direct use to animals, is essential to the growth of plants. Through the action of sunlight in the presence of chlorophyll, the green coloring matter of plants, carbon is taken from the carbon dioxide and united with other elements obtained from water and other materials absorbed through the roots. The plant in this way makes its own woody tissue, starch, sugar, proteins, and other compounds which it needs in its growth. The oxygen of the carbon dioxide is set free and returned to the air.

Carbon dioxide intercepts long heat waves and prevents radiation of heat from the earth.

When plants decay, or are burned, the carbon stored up in their tissues is returned to the air again as carbon dioxide.

★We have reason to believe that at the formation of the earth's atmosphere, early in its history, the carbon dioxide was a major constituent of the air. Certainly none of the coal and graphite now stored in the rock strata was there at that time, but must have been in the air as carbon dioxide; and an estimate, based on the amount of coal and graphite in the earth, tells us that there was about 40% carbon dioxide in the air at some past time.

Growth of plants on an enormous scale in the early periods of the earth's history (see page 271) extracted most of the carbon dioxide from the air, and formed thick and extensive deposits of coal, some of which have been changed to graphite. The amount of vegetation on the earth today is considerably less than it was in some of the past periods. It may be that we have now attained a balance: the plants extract carbon dioxide from the air, while the animals, together with decaying vegetation and combustion, return that same amount of carbon dioxide to the air. Besides its effects on living things, carbon dioxide has very important effects on rocks, as we have seen. It helps water to dissolve limestone, forming sinks and caverns; and from the solution, limestone is re-deposited as stalactites and other forms. From this solution also, marine animals precipitate the limestone to form their shells and other hard parts. Carbon dioxide helps in the attack on minerals containing iron, giving rocks their rusty appearance.

**298. Functions of nitrogen.** Nitrogen is a necessary element of the food of all plants, since it is a constituent of all protoplasm, present in the nucleus of every living cell. If the soil is lacking in this element, no plant will thrive. But nitrogen is not taken in by the plant directly from the air; it can make no use whatever of that *free nitrogen*. It needs *nitrogen compounds*, soluble in water, which are absorbed through the roots. When lightning passes through air, it unites some of the nitrogen and oxygen into a compound, which is carried down by the rain. Decaying plants and animals give off nitrogen compounds and hence are useful as fertilizers.

The class of plants called legumes — peas, clover, beans, alfalfa, etc. — are nitrogen gatherers. Colonies of bacteria, on their roots, seem to be able to take nitrogen from the air and change it into compounds, so that these plants are useful in cultivating other crops.

Man has learned to make, from air, artificial nitrogen compounds to supplement those in nature; and by this means he has increased many times the yield of the soil.

**299. Functions of water vapor.** The water vapor of the

air is the source of clouds, fogs, rain, snow, and several other forms of precipitation.

Moist air is less dense than dry air. Like carbon dioxide, it absorbs heat rays, and when condensed as clouds it is even more effective.

When it is precipitated as rain, it supplies water for growing plants; and as snow it retards radiation and protects crops from the intense cold of winter. This function of snow is very important in the wheat-growing regions of the northwest.

**300. Functions of dust.** Dust contains so many things, different in different regions, that only a few of its effects can be mentioned. The air carries pollen from one plant to another, and thereby assists in reproduction of these plants. Fermentation and putrefaction are brought about by constituents of dust, and the germs of many diseases are carried through the air.

Every dust particle in the air is a nucleus about which water vapor may condense; consequently, dust in the air promotes cloud formation and rainfall.

Dust scatters the short blue rays of light, making the sky blue; and it is only when the air is laden with dust that we get beautiful sunrise and sunset effects.

**★301. Origin of the atmosphere.** According to the planetesimal hypothesis of the origin of the solar system, this planet earth had no atmosphere when it was first formed, because it was so small that its gravitational influence on gases was too weak to hold them, and they were drawn away by other larger heavenly bodies. But as the earth grew by attracting other planetesimals, the gases expelled from the interior by volcanic emissions were held and ultimately formed the present atmosphere.

According to the nebular hypothesis of Laplace as well as the modern Jeans hypothesis, the present atmosphere is a remnant of a former much denser atmosphere. Before the earth was formed as a solid, it existed as a mixture of gases. As cooling took place, one by one the denser materials have liquefied and solidified; first the rocks and the metals, then the liquids like water, each substance

separating out as the mass cooled below its boiling point. The substances left in the air today will turn to liquids if the earth is cooled sufficiently. We should then have no water but ice; and lakes and seas would be made of liquid air.

### *Completion Summary*

The atmosphere is at least \_\_\_\_\_ high.

Air in motion is called \_\_\_\_\_. It causes \_\_\_\_\_ erosion and dust \_\_\_\_\_.

The important substances in the air, from the standpoint of the physiographer, are \_\_\_\_\_, \_\_\_\_\_, \_\_\_\_\_, and \_\_\_\_\_.

Oxygen is essential to \_\_\_\_\_ on the earth, and attacks, chemically, \_\_\_\_\_, so that it is an important agent \_\_\_\_\_ of rocks.

Carbon dioxide is a very important substance for \_\_\_\_\_.

★In the early history of the earth, we believe \_\_\_\_\_ 40% carbon dioxide, which by growth of plants on an enormous scale \_\_\_\_\_, leaving the air as it is today, with \_\_\_\_\_ 1% carbon dioxide.

Nitrogen is essential for \_\_\_\_\_, and every \_\_\_\_\_ must have \_\_\_\_\_ nitrogen.

The \_\_\_\_\_ of the air is responsible for most of the changes \_\_\_\_\_ weather.

Dust \_\_\_\_\_ clouds and rain.

According to the planetesimal hypothesis, the earth at first \_\_\_\_\_ atmosphere. Our present atmosphere is an accumulation \_\_\_\_\_.

★According to the nebular and tidal disruption theories, our atmosphere \_\_\_\_\_ remnant \_\_\_\_\_, due to gradual \_\_\_\_\_.

### *Exercises*

1. How high is the air, according to observations on meteors? Why is this not conclusive?
2. How can it be shown that air has weight?
3. Compare buoyancy in air and in water by an example.



4. Which constituent of air varies very much?
5. What is the approximate ratio, in whole numbers, of nitrogen to oxygen in the air?
6. Where does the per cent of carbon dioxide increase?
7. Of what value to plants is carbon dioxide?
8. Why does the per cent of water vapor in air vary so much?
9. Name five substances present in dust.
10. In what respects is country air purer than city air?
11. Which constituents of air decrease with elevation?
12. Why do we ventilate our homes?
13. What effect has oxygen in the animal's life?
14. What is the effect of oxygen on metals?
15. How does oxygen affect rocks?
16. How does carbon dioxide indirectly affect the lives of animals?
17. What is the effect of carbon dioxide on rocks?
18. What rocks owe their origin to carbon dioxide?
19. What effect has carbon dioxide on marine animals?
20. Why is nitrogen vitally necessary to plants and animals?
21. In what form is nitrogen used by plants? In what form is it useless?
22. Why is water vapor the most important constituent of the air, in changes of weather?
23. What constituents of the air have an effect on radiation of heat from the earth? What is this effect?
24. What effect has dust on weather?

**★Optional Exercises**

25. Why can we not find the height of the atmosphere from the pressure and density, as we can with water?
26. Why does a balloon rise in air?
27. Explain photosynthesis, mentioning carbon dioxide, water, starch, and oxygen.
28. Why do we believe there was 40% carbon dioxide in the air at some past stage of earth history?
29. What is supposed to be the origin of the atmosphere, according to the planetesimal hypothesis? the nebular hypothesis? the tidal disruption theory?

## CHAPTER XXIV

### THE TEMPERATURE OF THE AIR

**302. Variations of temperature.** The sun is the chief source of our heat. The days are warmer than the nights, and it is warmer when the days are longer. As we move toward the equator, it becomes warmer because the sun's rays are more nearly vertical; the sun is more nearly overhead. The coldest season is that in which the nights are longer than the days and when the sun hangs low in the sky.

There are other sources of heat besides the sun. One of them is the heat of the earth, which warms up deep mines and is important in volcanoes and hot springs.

The surface of the land varies in temperature from day to night and from summer to winter; but if we descend below the surface, the variation is less and less, and we finally reach a level where the temperature from summer to winter, during night and day, is about the same. If we descend farther than this level, it gets warmer and warmer. From these observations we conclude that the interior of the earth is intensely hot.

On the other hand, if we ascend in the air, it grows colder, and at the elevation of only a few miles (beyond the snow line on mountains) freezing temperatures, even in summer, are reached. It has been determined by sounding balloons, sent up with automatic recording instruments but without men, that the temperature decreases up to about 6 miles, after which it remains the same,  $-67^{\circ}$  F. This zone of constant temperature is the *stratosphere*.

**303. Insolation.** The radiant energy that comes to us from the sun is called *insolation*. It travels at the enormously rapid rate of 186,000 miles per second. It includes visible

light waves as well as infrared, or long waves, and ultraviolet, or chemical rays, which are short. Infrared radiation is the chief source of our heat. Ultraviolet rays produce sunburn, cause plants to grow, affect photographic film, and bring about other chemical effects. Heat is energy of molecular motion, and a body that is heated increases its molecular motion.

Heat passes from a hot to a colder body, that is, from a body of higher to one of lower temperature. The sun, being much hotter than the earth, radiates heat energy to us. The distance between us is, however, so great (93 million miles) that we intercept only a very small fraction of the sun's radiation. But still this energy amounts to enough to yield  $1\frac{1}{2}$  horsepower for each square yard of the earth's surface, if it were absorbed at 100% efficiency. It is upon this minute part of the total solar energy that all our life and activities depend.

**304. What happens to insolation?** When insolation is received, it is disposed of in three ways: by reflection, by transmission, and by absorption. It is only absorbed insolation that makes a body hotter.

Some substances are good reflectors, some are good transmitters, and some are good absorbers. In general, gases are the best transmitters, liquids the best reflectors, and solids the best absorbers. This is shown in the table below:

DISPOSAL OF INSOLATION BY LAND, WATER, AND AIR

	BY LAND	BY WATER	BY AIR
Reflected	Some	Much	Very little
Transmitted	Very little	Some	Very much
Absorbed	Very much	Some	Very little

The absorptive power of a body may be materially modified by a change of color or of surface. Dark-colored and irregular surfaces absorb better, while brightly colored and smooth surfaces reflect better. By increasing the reflecting power of a body we decrease its absorption.

A good absorber is a good radiator of heat; hence increasing its reflecting power diminishes its radiation.

**305. Transfer of heat.** There are three modes of heat transfer: *conduction*, *convection*, and *radiation*.

In solids, conduction is the chief means of transferring heat. Heat is molecular motion. When a solid is heated at one end, the motion of the molecules increases, they bombard neighboring molecules and give up some of their motion to them; in this way, the increased molecular motion — heat — is carried from one end to the other. This is conduction. Since increased heat means increased molecular motion, *heat causes substances to expand*.

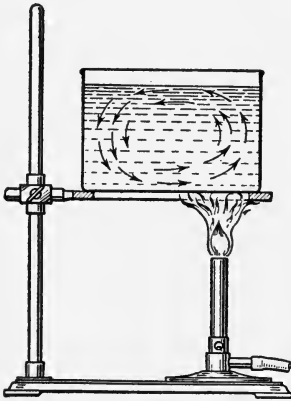

FIG. 235. Convection in a Liquid

Metals are the best conductors; most solids are better than liquids; and liquids are better than gases.

Convection of heat can take place only in liquids and gases. When a vessel of water is heated (Fig. 235), the molecules at the bottom of the vessel move more vigorously. The liquid expands and becomes less dense, so that an equal volume of colder liquid weighs more than the warm liquid. The colder, heavier liquid drops down, therefore, and pushes the warmer liquid up. In this way the colder liquid becomes warm in its turn, until the entire contents are warmed. The continuous movement of the warm and cold portions of the liquid creates a *convection current*. It is apparent that convection cannot take place in solids. Convection in air is analogous to convection in liquids.

Radiation is quite different from convection and conduction. Whereas these can take place only in a material medium, radiation can pass through space itself, entirely devoid of matter. Conduction and convection are slow, but radiation

is instantaneous. The difference can be shown by comparing the heating effect of an open fire with that of a steam radiator. One is *instantly* warmed by radiation from the open fire, whereas the steam-heating system may take an hour or more to warm a room by convection currents in the air. (The steam radiator does not do much radiating.)

A body radiates heat to every other body which is cooler than itself, *whether it is in contact with it or not*, but conduction and convection can take place only between bodies which are in contact.

**306. How the atmosphere is heated.** Dense air absorbs more heat than rare air. Carbon dioxide, water vapor, and dust absorb better than air.

When insolation passes through air, very little is absorbed by the upper layers of air. As it penetrates farther and farther into the denser, dustier, and moister air, more and more is absorbed and the air is more and more heated. The air is heated most at the bottom, not only because of the increased absorbing power of the lower layers, but also because of their contact with the warmer land and water surfaces.

Another very important aid in the heating of the air near the earth is its convectional mixing. The heated lower air expands and the cooler, heavier air above sinks and takes its place. In this way the entire mass of air would ultimately be warmed.

The convectional rise of heated air may be observed above a heated stove or a bonfire. Rooms are ventilated by admitting cool, fresh air at the bottom and permitting the escape of the heated air above.

**★307. The stratosphere.** This process of convection takes place only in the lower layers of air, up to about 6 miles. It has been learned by sounding balloons that the temperature decreases with altitude up to 6 miles, after which it remains the same,  $-67^{\circ}$  F. If there is no difference in temperature, there can be no convection except that due to density. It follows then, that, while the air

below 6 miles has its oxygen, nitrogen, etc., all mixed up by convection, the air above that point is stratified; that is, there is a layer of carbon dioxide, the densest gas, a layer of oxygen, one of nitrogen, then helium, and hydrogen at the top, since hydrogen is the least dense of all gases.

This portion of the atmosphere is called the *stratosphere* because the gases are supposed to be stratified. A recent balloon ascent into the stratosphere has failed to confirm this stratification, but

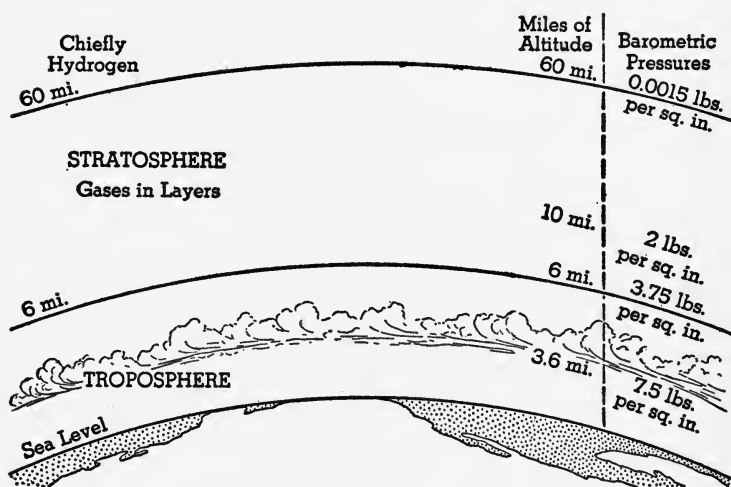

FIG. 236. The Atmosphere

the volume of air brought down was very little, and new tests are being made to determine this point.

But whether or not the gases of the stratosphere are stratified, the evidence that the *temperature is constant* is definitely established. Hence this part of the atmosphere is called, by Humphreys, the *isothermal layer*, which means the layer of constant temperature.

We shall have very little to do with the stratosphere in our study of winds, clouds, and weather, since there is quiet in the stratosphere. All the movement takes place in the region below the stratosphere, called the *troposphere* (Fig. 236).

There is practically no water vapor in the stratosphere because

of the very low temperature, and hence no clouds. The absence of water vapor has an important effect on the amount of ozone, and this, in turn, has important effects on the amount of insolation received by the earth. Ozone is a form of oxygen. When ultraviolet light passes through oxygen, ozone is formed; but it is changed back to oxygen again by water vapor. In the stratosphere, where water vapor is practically nonexistent, there is more ozone. This ozone in the stratosphere has two effects on insolation. It protects the earth from excessive ultraviolet radiation and acts as a blanket, together with the carbon dioxide, water vapor, and dust of the troposphere, to prevent earth radiation — the so-called “greenhouse effect.”

Ozone is believed to have another effect. It has long been noticed that during times of maximum solar radiation, when sunspots face the earth, the earth receives less heat from the sun; in other words, *the hotter the sun, the cooler the earth*.

This may be explained as follows. At sunspot minima there is more ultraviolet radiation. This produces more ozone in the stratosphere, which exerts its blanket effect on the earth to intercept radiation. Ozone is seven times more effective in absorbing *earth* radiation than *solar* radiation.

**308. How air is cooled.** At night, when insolation ceases, the conditions are reversed. Radiation *from* the earth cools it off. Radiation also takes place during the day; but at that time the air gains more than it loses, while at night it loses more.

Since a good absorber is a good radiator, the lower portions of the air are cooled most when insolation ceases. The rare upper portion is little affected, because there will be no convection when the lower layer of air is cooled, since the cool air is heavier. On this account *the lower air warms up faster than it cools down*.

The coldest hours of the day are from 4 to 6 A.M., and the warmest from 1 to 3 P.M., depending on the season. Thus it takes from 7 to 9 hours for the air to warm up, from 15 to 17 hours to cool down.

Water vapor, carbon dioxide, ozone, and dust retard the

earth's radiation. A clear night in winter is cold because of the absence of clouds.

In Florida and California, *smudges* are used to prevent freezing of the buds on fruit trees at night. Smudges are small fires that cover the orchard with a blanket of smoke. The dust and carbon dioxide exert their blanketing effect, and frost is often avoided.

**309. Thermometers** are instruments for measuring the temperature. The ordinary thermometer is a tube of mer-

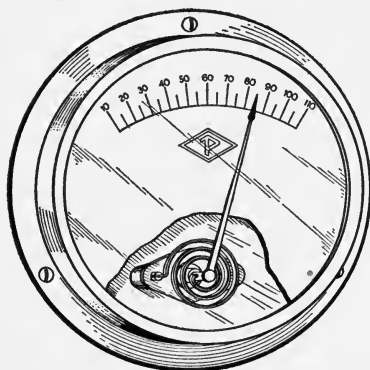

FIG. 237. A Metallic Thermometer

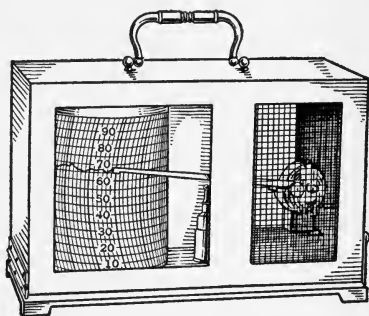

FIG. 238. A Thermograph

cury, which expands when it is heated. Alcohol is used in cold climates, because mercury freezes there.

Some thermometers use the expansion of metals, like brass, to measure temperatures. A coil of the metal unwinds as it is heated, and moves a pointer on a dial (Fig. 237). The *thermograph*, an instrument which automatically records temperatures, is constructed on this principle (Fig. 238). The thermograph gives a daily and hourly record of temperatures.

In the United States and other English-speaking countries, the Fahrenheit thermometer is in common use. The peoples of most European countries, and scientists the world over, use the centigrade thermometer. Both thermometers are alike in construction but differ in the scale of degrees used (Fig. 239).



In making either thermometer, the tube is filled with mercury and sealed. The boiling point is marked by placing the thermometer bulb in the steam from boiling water.

Then the freezing point is determined by placing the bulb in melting, cracked ice. For a centigrade thermometer, these points are marked  $100^{\circ}$  and  $0^{\circ}$ , respectively; and for a Fahrenheit thermometer, the same points are marked  $212^{\circ}$  and  $32^{\circ}$ .

**310. Distribution of insolation.** The amount of insolation received by a given area of land or water in a given time depends mainly upon the following factors:

1. Solar radiation, intensity, and duration
2. Distance from the sun
3. Angle of insolation
4. Absorption by air

**311. Intensity of solar radiation.** The earth receives a very tiny fraction of the sun's radiation, but even that small amount is sufficient, if completely transformed, to yield 1.5 horsepower per square yard of surface, which, from our point of view, is stupendous.

Whether the sun is radiating heat at a uniform rate from year to year we are not certain, because observations are too few to draw a valid conclusion. But it is known that there is a 2% variation due to sunspots. It is found that the average temperature of the earth is *higher when sunspots are at a minimum*, although the sun at such times is radiating with greater intensity. This has already been explained in paragraph 307.

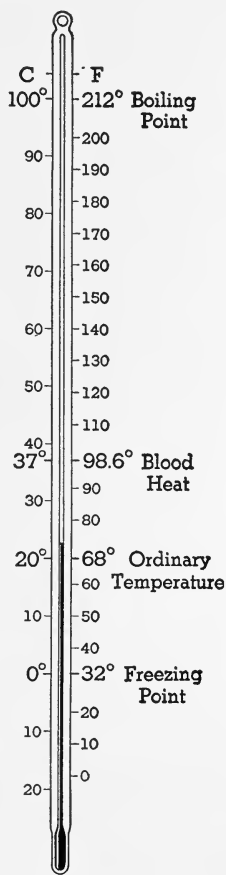

FIG. 239. A Thermometer with Centigrade and Fahrenheit Scales

The chief variation in solar intensity is in the ultraviolet rays; these are at times twice as intense as at others.

Because of the inclination of the earth's axis, the period of insolation, or number of hours of sunshine, is not the same for all places; and it also varies from day to day at any particular place. No place, besides the equator, always has 12 hours of daylight and 12 hours of darkness. In other places that will be true at the equinoxes, twice a year. At other times the period of daylight will be longer than 12 hours when the sun is on the same side of the equator as the observer, and shorter than 12 hours when on the opposite side of the equator.

In the polar circles the period of continuous sunlight is as much as 24 hours or more in midsummer, while in midwinter there is none.

Not considering other factors, the amount of insolation increases with the number of hours of sunlight. In Norway, within the Arctic Circle plants grow at abnormal speeds, and some of them to abnormal size during the short summer, because the period of insolation is at times as much as 24 hours or more.

**312. Effect of distance from the sun on insolation.** The earth is about three million miles nearer the sun at perihelion, about January 1, than at aphelion, about July 1. In consequence, a place receiving vertical insolation around January 1 receives almost 7% more insolation than one receiving vertical insolation around July 1. This makes a difference in temperature of about 7° F.

Since the earth is nearer the sun during the winter of the northern hemisphere, our winter is warmer and our summer cooler than they would be, otherwise.

**313. Effect of angle of insolation.** Increasing obliquity, or slant of the sun's rays, is proportional to decrease of insolation; and actually, the insolation absorbed decreases faster than the angle. It is found that while water reflects only 2% of *vertical* insolation, it reflects about 65% when

the sun is only  $10^{\circ}$  above the horizon. On this account, the early morning and late afternoon rays, as well as the rays received in regions far from the equator, have little effect in increasing temperatures. For this reason alone, the poles could never be warm.

When we consider also the fact that in the polar regions the lands and frozen seas are for much of the year covered with snow and ice, both very poor heat absorbers, and that the heat they receive must *first be used to melt* the snow and ice, before they can be warmed up, we can better understand the low temperatures which prevail there. When ice is melting, it remains at the *same temperature* throughout the process, even though it absorbs a great amount of heat.

The northern hemisphere, where there is much more land area, is warmer in summer and colder in winter than the southern hemisphere, because of the greater area of water there. This is due to the fact that the land is a better absorber and also a better radiator than water; and furthermore it takes more heat to warm up water than land, weight for weight.

The direction and character of winds and ocean currents and the differences in the elevation of land are likewise important factors in the distribution of *heat* over the earth.

All things combine to give the regions along the equator the greatest total amount of heat; and the change in heat during the year is least there.

**314. Absorption of insolation by air.** We have been considering, thus far, the amount of insolation *received* from the sun; but what really counts is not that, but the amount *absorbed* by our air.

Much of it is reflected by clouds and earth, and some is scattered by dust and other constituents of air. It is estimated that about half the sun's insolation is lost in these ways.

Dust scatters some rays, carbon dioxide, ozone, and water vapor absorb heat rays, while oxygen, when dry, takes up ultraviolet rays.

**315. Shifting of the heat equator.** The zone of greatest heat near the equator is known as the *doldrum* belt, or simply the *doldrums*. The irregular line in this belt, passing through places with the highest temperatures, is called the *heat equator* (Fig. 240). Since the sun's vertical rays shift during the year, so also the doldrums and the heat equator shift (Fig. 241).

The temperature of a place continues to increase as long as more heat is received than is lost by radiation. The cooling down begins ordinarily an hour or two past noon, although most heat is received *at* noon; and the highest temperature of the year occurs usually some weeks after the longest day, although most heat is received on that day. The heat equator, therefore, does not attain its extreme position, north and south, at the times when the sun is at its most northerly and most southerly positions, but weeks after. Places in between these extreme positions, having vertical insolation twice annually, have two maximum and two minimum temperatures during the year and experience their highest maximum temperature, shortly after vertical insolation, upon the sun's return toward the equator.

Being a better absorber and better radiator than water, land has a higher temperature in summer and a lower temperature in winter than the sea near it. This excessive warming and cooling is most pronounced in its effects in the northern hemisphere, where the great land areas are; and it is also more pronounced over the relatively narrow Atlantic than over the broader Pacific (Figs. 240 and 241).

**316. Average position of the heat equator.** The heat equator shifts farther and remains for a longer time north of the geographical equator than it does south of it. This is, in part, because the sun is seven days longer north of the equator than south of it, and also because of the shape of the continents and oceans. Owing to the positions and outlines of continents, more of the warm ocean currents are

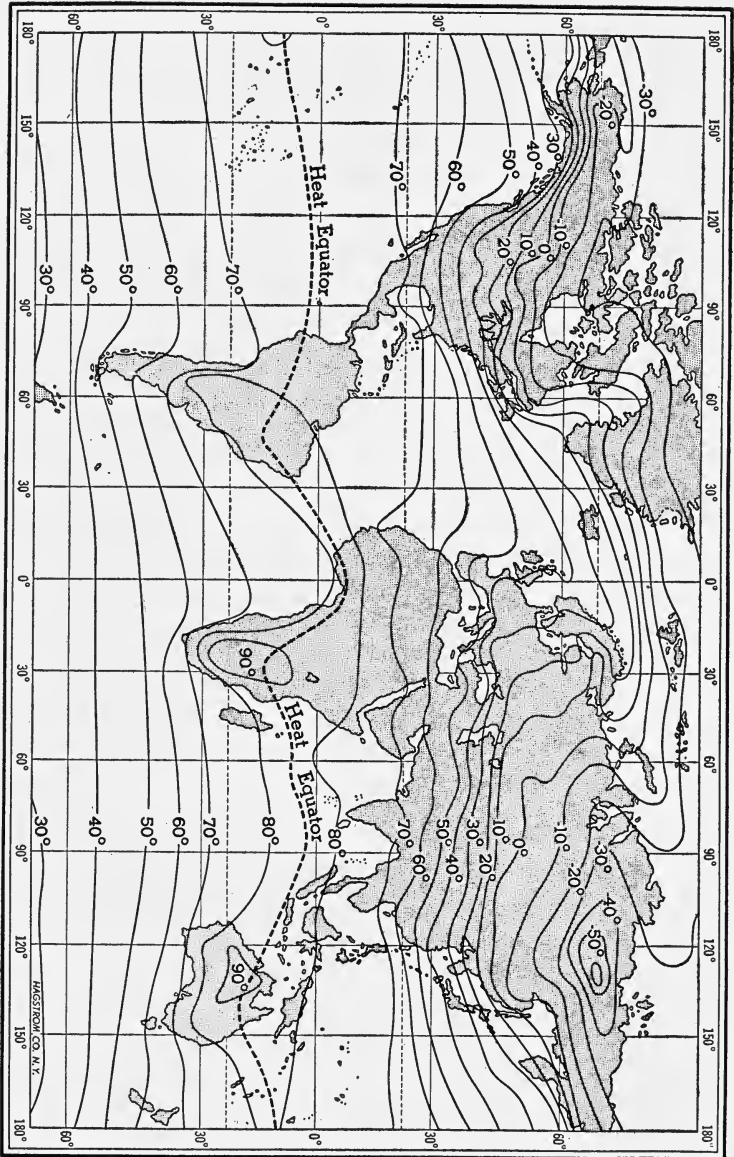

Fig. 240. Isothermal Chart for January, Showing the Heat Equator

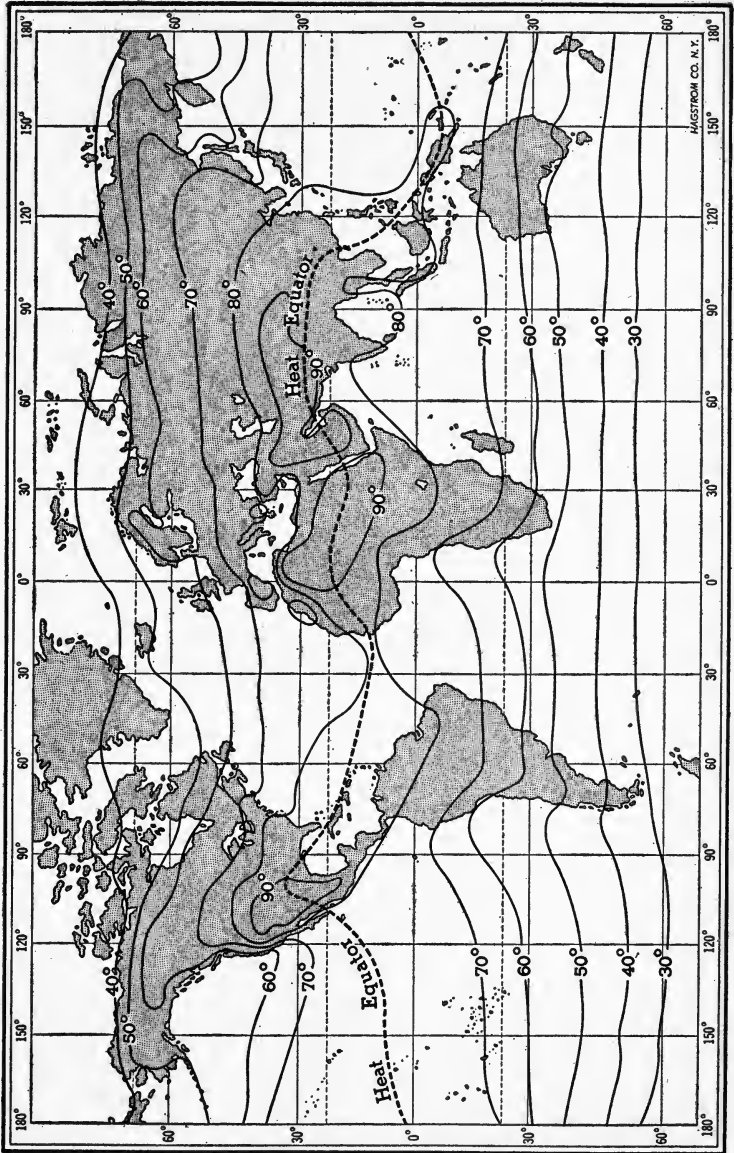

FIG. 241. Isothermal Chart for July, Showing the Heat Equator Farther North than in January. (See Fig. 240)

turned into the northern oceans than into the southern and these make the northern hemisphere somewhat warmer.

Moreover, the Pacific Ocean, being almost closed on the north, shuts out the cold polar currents and remains warmer than the Atlantic, which is open at the north.

**317. Isotherms.** Lines drawn through places having the same temperature at the same time are called *isotherms*. They may represent the temperature at a particular time or the average for any given period — a week, a month, or the entire year.

Such lines, while very irregular, have in general an east-west direction (Figs. 240 and 241). This is what we should expect, since the number of hours of sunlight as well as the angle of insolation depend upon the distance from the equator, and therefore these lines should be parallel to the equator.

Isotherms are continuous lines which for a limited area may appear on the map as closed curves. From the definition, two isotherms cannot intersect. The *heat equator is not an isotherm*, though it extends around the earth in the same general direction as isotherms. It may even cross isotherms.

★**318. Temperature gradient.** If we pass from one isotherm to the next of higher or lower temperature, we must pass through all the intermediate temperatures. There might be many routes by which one could go from a place on one isotherm to a place on the other; but the shortest route would give the greatest rate of change of temperature. This *shortest route* is the direction of the *temperature gradient*.

*Temperature gradient may be defined as the rate of change of temperature between two places.* The closer together the isotherms, the more rapid the change of temperature, or, as we say, *the steeper the gradient*, while widely separated isotherms indicate gentle gradients.

### **Completion Summary**

The temperature of the air ——— as we ascend. At an elevation of about ——— miles, the temperature ———. This is called ——— layer or ———.

The heat received from the sun is called \_\_\_\_\_. Land warms up \_\_\_\_\_, while water \_\_\_\_\_, and air \_\_\_\_\_.

Heat is transferred from a hotter to \_\_\_\_\_ by three methods: \_\_\_\_\_, \_\_\_\_\_, and \_\_\_\_\_. Solids \_\_\_\_\_ heat; in liquids and gases heat is transferred by \_\_\_\_\_; all bodies \_\_\_\_\_ heat to \_\_\_\_\_ bodies.

The air is heated most, near \_\_\_\_\_; this air \_\_\_\_\_ and rises, and the cooler air \_\_\_\_\_ and is warmed, in turn. This is a \_\_\_\_\_ current.

★The atmosphere up to \_\_\_\_\_ miles is called the \_\_\_\_\_; above that, it is called \_\_\_\_\_. Here \_\_\_\_\_ convection, because there is no \_\_\_\_\_, and it is believed the different gases have separated \_\_\_\_\_, with a layer of \_\_\_\_\_ at the top.

There are no clouds in \_\_\_\_\_, and hence ultraviolet radiation transforms oxygen into \_\_\_\_\_. This protects the earth from \_\_\_\_\_ and prevents earth heat from \_\_\_\_\_.

At night, the earth \_\_\_\_\_ heat. This loss \_\_\_\_\_ is modified by the presence in the air of \_\_\_\_\_, \_\_\_\_\_, \_\_\_\_\_, and \_\_\_\_\_.

On the Fahrenheit thermometer, the boiling point of water is \_\_\_\_\_ and the \_\_\_\_\_ is  $32^{\circ}$ . On the centigrade thermometer, the boiling point is \_\_\_\_\_ and \_\_\_\_\_ $0^{\circ}$ . Ordinary room temperature is \_\_\_\_\_ $^{\circ}$ C. or \_\_\_\_\_ $^{\circ}$ F.

The amount of insolation received at any place depends on the number \_\_\_\_\_ sunshine and the angle \_\_\_\_\_.

More heat is absorbed \_\_\_\_\_ than by \_\_\_\_\_. On that account, the northern hemisphere \_\_\_\_\_ than the southern. The heat equator, or line of \_\_\_\_\_ temperature, shifts because \_\_\_\_\_. It remains \_\_\_\_\_ for a longer time.

Isotherms are lines on the \_\_\_\_\_ passing through \_\_\_\_\_.

★The temperature gradient is represented by the \_\_\_\_\_ line that can be drawn between two \_\_\_\_\_.



*Exercises*

1. How does the temperature change as we descend into a mine?
2. What evidence have we that the interior of the earth is very hot?
3. How does the temperature change as we ascend in the air?
4. What happens to the temperature beyond an elevation of seven miles? What do we call this part of the air?
5. If the interior of the earth were the chief source of heat, what part of the earth's surface would be the hottest?
6. How do water and land compare in heat absorption?
7. Which substances conduct heat best?
8. What is the chief method of heat transfer in liquids? in gases?
9. By which method is heat transferred from the sun to the earth?
10. Where is the atmosphere heated most? Why?
11. What is a convection current? How do we use it in ventilation? in heating liquids?
12. Why does the lower air warm up faster than it cools off?
13. What are the coldest and the warmest hours of the day?
14. What constituents of the air retard radiation from the earth?
15. Why is it colder on a clear night, in winter, than on a cloudy night?
16. Explain the use of smudges in Florida orchards.
17. What is a thermograph? What is the actuating device?
18. What are the boiling and freezing points on the centigrade and Fahrenheit thermometers?
19. What are, approximately, the ordinary room temperatures on each scale?
20. What is the variation in solar radiation? To what is it due?
21. What kind of solar radiation shows the greatest variation?
22. Upon what does the amount of sunlight received at any place depend?
23. Explain the rapid growth of vegetation, in Norway, during the short summer.
24. Why do some places north of the equator receive more

insolation than places at the same south latitude? How much more?

25. What effect has the angle of insolation on the heating power of the sun's rays?

26. State several reasons for the low temperatures of the polar regions.

27. Why is the northern hemisphere colder in winter and hotter in summer than the southern hemisphere?

28. In what part of the earth is the variation of temperature least? Why?

29. Where is the heat equator? Why does it shift?

30. Why does the heat equator remain in the northern hemisphere longer than in the southern?

31. What are isotherms?

32. Why cannot two isotherms intersect?

#### ★*Optional Exercises*

33. The higher we ascend in the air, the more intense the insolation, yet the colder it is. Explain.

34. Why are the gases in the isothermal layer thought to be stratified?

35. Why are there no clouds in the stratosphere?

36. Why are all winds confined to the troposphere?

37. Explain the *greenhouse effect* of ozone. Why is this more important in the stratosphere?

38. Why is the earth cooler when sunspot activity is greatest?

39. Explain how oxygen absorbs ultraviolet rays.

40. What is meant by the *temperature gradient*?

## CHAPTER XXV

### AIR PRESSURE

**319. Air has weight.** Many errors are made in regard to air, because it is an invisible mixture of gases. An "empty bottle" is really a bottle *full of air*. "A balloon rises because hydrogen weighs less than nothing" should be "a balloon rises because hydrogen weighs less than its own volume of air." Air has weight. This can be shown by weighing an

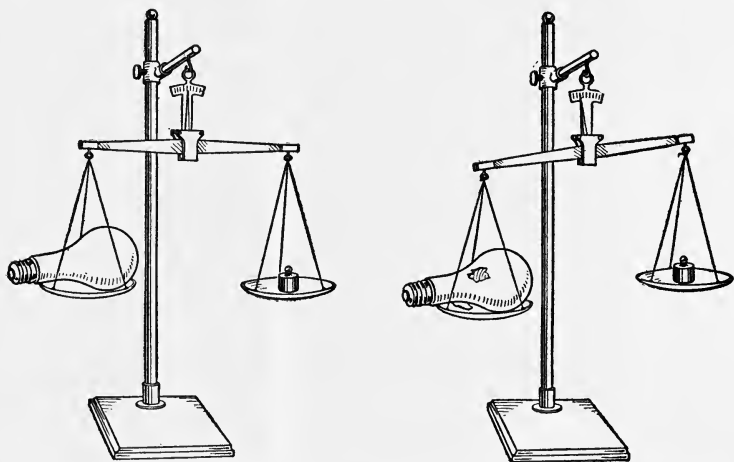

FIG. 242. The lamp weighs more after it is punctured.

evacuated electric lamp, then puncturing it and reweighing. It weighs more when the air is permitted to enter (Fig. 242).

Air weighs 1.3 grams per liter, or about 1 pound for 12 cubic feet. This is called the *density of air*. The air in a room 14 feet long, 12 feet wide, and 10 feet high weighs about 140 pounds.

**320. Air pressure.** We live at the bottom of a sea of air and, since air has weight, it presses down upon everything

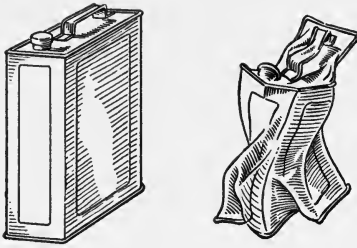

FIG. 243. Effect of Air Pressure on a Tin Can from Which the Air Has Been Exhausted

in it. The air pressure amounts at sea level to 14.7 pounds on every square inch of surface. This is equal to several tons for every human being. How do we sustain it? The heart pumps the blood to every part of the body with a pressure slightly greater than air pressure. In fact, blood pressure is sometimes so much greater than air pressure, on high mountains, that a blood vessel is ruptured. In other words, the

is sometimes so much greater than air pressure, on high mountains, that a blood vessel is ruptured. In other words, the

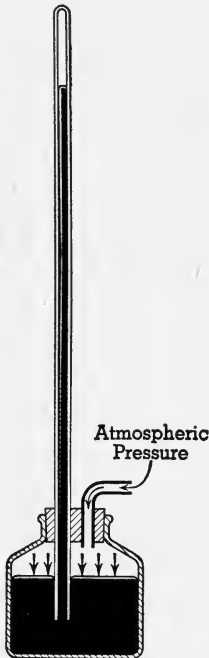

FIG. 244. A Homemade Mercury Barometer

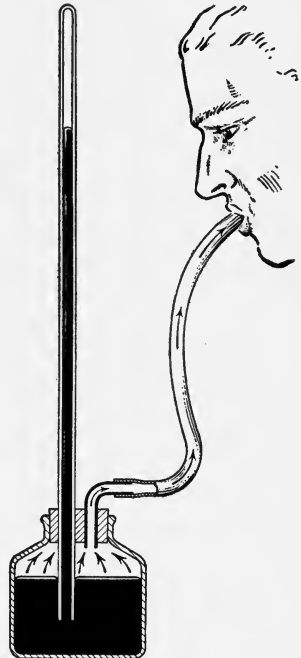

FIG. 245. The mercury column is lower here than in Fig. 244. Why?

air pressure decreases as we go up, so that at an elevation of 6 miles, it is only 4 pounds per square inch, and at 10 miles it

is 2 pounds per square inch. If the air is removed from a tin can, it can be crushed by the external air pressure (Fig. 243).

**321. The barometer.** If we fill a glass tube, 34 inches long, with mercury and invert it in a vessel containing mercury, the mercury does not fall down, but remains at a height of about 30 inches (Fig. 244). Referring to Fig. 245, if some of the air is sucked out of the bottle, the mercury falls. If more air is blown in, the mercury rises. This can be explained as follows: The air itself holds up a mercury column 30 inches high, because the air over a square inch weighs as much as a column of mercury 30 inches high, over a square inch. *Each of them weighs 14.7 pounds.* Remove some of the air and the pressure, being less than 14.7 pounds per square inch, cannot hold the mercury up 30 inches high. Blowing into the bottle increases the air pressure and forces the mercury up more than 30 inches.

We may say then that the mercury column balances the air pressure; hence we use it to measure air pressure, and call it a *mercury barometer*.

The glass tube is usually surrounded by a metal tube for protection and with some device for measuring the height of the mercury column (Fig. 246).

**322. The aneroid barometer.** The mercury barometer is very inconvenient to carry up a mountain or in an airplane. For such purposes we use the *aneroid* barometer. Aneroid means *without liquid*.

In Fig. 243 it was shown that a tin can could be crushed by removing the air from the can. Now suppose we remove only a little of the air. In that case the walls of the can will

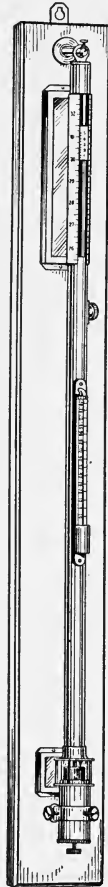

FIG. 246. A Mercury Barometer

be forced in only a little (Fig. 247). If then the air be permitted to return, the can returns to its normal shape and size. Again, if air is blown into the can, its sides bulge outward. *This is the principle of the aneroid barometer.* A small flat metal box is partially exhausted and sealed. One surface of the box is connected to a spring which moves a pointer across the scale (Fig. 248).

**323. Variation in barometer readings.** At sea level the average reading of the barometer is 30 inches. As the instrument is carried up through the air, the "barometer drops"

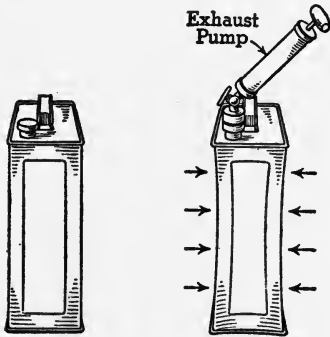

FIG. 247. Principle of the Aneroid Barometer

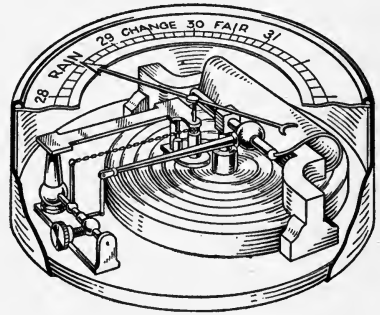

FIG. 248. An Aneroid Barometer

about one inch per thousand feet, because it is the air *above* which causes the pressure. It does not continue to drop at the same rate, however. For example, here are actual figures: at the 910-foot level the barometer dropped 1 inch; at the 1850-foot level, it dropped 2 inches. This is because the density of air decreases with altitude; the air itself is affected by the pressure and *one cubic foot of air at sea level weighs more than anywhere above sea level.*

The barometer reading is never stationary, even at sea level. It changes from day to day and from hour to hour. We can understand these changes if we imagine the air as continually in motion (Fig. 249). Like the sea, there are huge waves on the surface of the sea of air, and the pressure

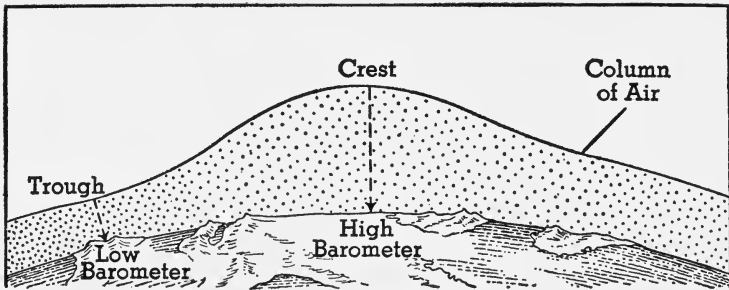

FIG. 249

under the crest of a wave is greater than it is under the trough. Furthermore the sea of air, like the ocean of water, is subject to tides.

Again, moist air is less dense than dry air; hence a column of moist air will weigh less and the barometer will be low. Cold air is more dense, giving us a higher barometer in winter. If a continuous record of air pressures is desired, an instrument called the *barograph* is used. The barograph is an aneroid barometer with a pen attached to the pointer (Fig. 250). The record is attached to the drum which is turned by a clock, giving weekly records of barometer readings.

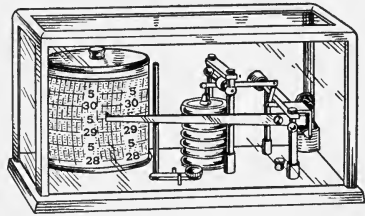

FIG. 250. A Barograph

**324. Isobars.** If a stationary barometer is read from hour to hour, it will be noted that its readings change continually. This seems to be due to a series of surges or waves in the upper atmosphere. These are called *lows* and *highs*. Lows are sometimes called *cyclones*, and highs, *anticyclones*.

If our barometer registers a low, it will be found that as we move away from our position *in any direction*, the barometer will be higher, and vice versa for a high. We may draw lines through places having the *same* barometer read-

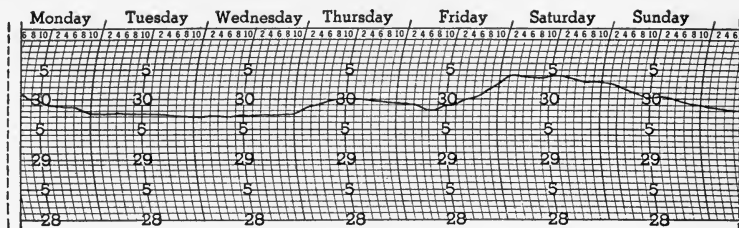

FIG. 251. A Barograph Record

ing. Such lines are called *isobars* (Fig. 252). About strongly developed lows and highs the isobars are closed curves and approximately parallel.

The isobars about a high may be likened to the contours of a hill on a topographic map; those about a low are similar

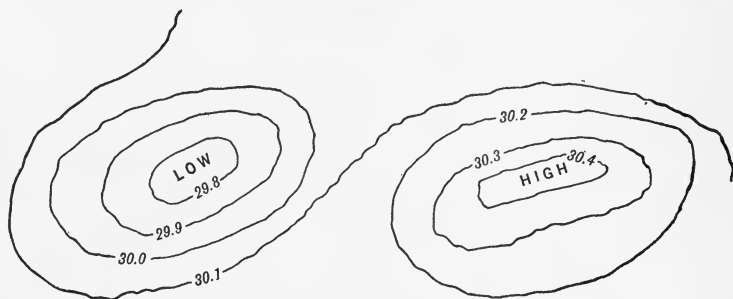

FIG. 252. Isobars about a Low and a High

to the contours of a depression, the low being an atmospheric basin.

**325. Pressure gradient.** Just as the temperature gradient is the shortest distance from one isotherm to the next, so we may get the *pressure gradient* at any place by taking the shortest distance between the isobars at that place.

*The pressure gradient is the rate of change of pressure between two places; and, like the temperature gradient, it is in the direction of the most rapid change.* Crowded isobars, therefore, mean *steep* pressure gradients. We shall see that the direction and strength of the wind are closely related to the pressure gradient.



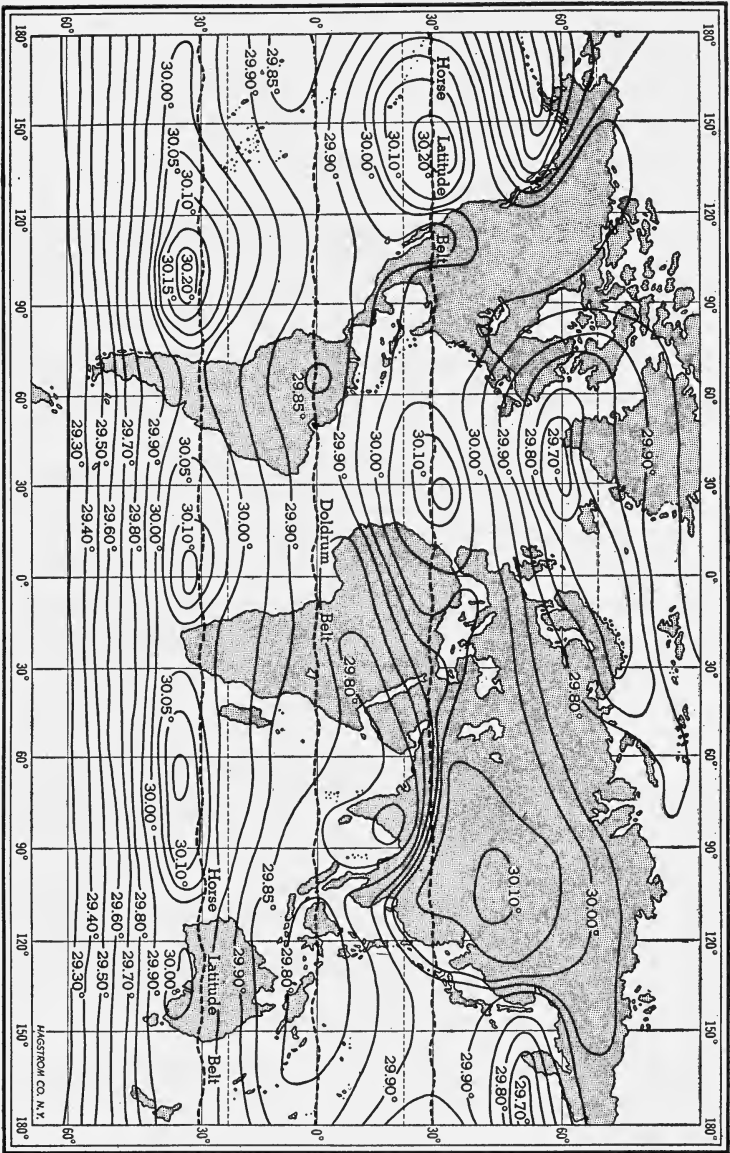

Fig. 253. Annual Isobars, Showing Doldrums and Horse Latitudes

**326. Pressure belts.** The distribution of pressure over the earth depends upon the temperature; high temperature causes low pressure. The equatorial belt is therefore a region of *low pressure*. This region is known as the *doldrums*. North and south of the doldrums, in the two temperate zones of the earth, there are regions or belts of high pressure called the *horse latitudes*. These lie around latitude  $30^{\circ}$  N and  $30^{\circ}$  S.

Toward the poles the pressure decreases. As a result of this arrangement of pressures, the isobars of the world have a general east-west trend, and shift with the heat equator.

**327. Uses of the barometer.** The barometer is used by mountain climbers and aviators to determine altitudes; but the most important use of the barometer is in forecasting weather.

When there is a difference of pressure between two places, there will be a movement of air, a wind, from the place of high to that of low pressure; and the steeper the pressure gradient, the greater the velocity of the wind.

In order to forecast the movements of air, it is necessary to have barometer readings from many places, and the government maintains meteorological stations at numerous points all over the country.

### *Completion Summary*

Air ——— weight, and because of that ——— pressure. The pressure of the atmosphere at ——— is equal to ———. At higher altitudes ——— is less. Air pressure ——— barometer.

The mercury column at sea level ——— inches. The aneroid barometer has no ———, and it is therefore more ——— than the ——— barometer.

A steep pressure gradient is shown, on a map, ———. ——— is a region of low pressure. It is near the ———. The horse latitudes are in the ——— zones. They are regions of ——— pressure.

A barometer is one of the instruments ——— weather.  
Winds ——— region of low pressure.

### *Exercises*

1. What is usually meant by an empty bottle?
2. What is meant by the density of air?
3. State the air pressure, in pounds per square inch, at sea level.
4. How do we know that blood pressure is greater than air pressure?
5. Explain how a tin can is crushed by removing air from the can.
6. What is a barometer?
7. Explain why the mercury column drops when the air pressure diminishes.
8. What is an aneroid barometer? Why is it more convenient than a mercury barometer?
9. Why does the barometer drop as we ascend a mountain?
10. Why is the barometer low in moist weather?
11. Why is the barometer often lower in summer than in winter?
12. What is a cyclone? an anticyclone?
13. What are isobars?
14. How do we find the pressure gradient?
15. What is a barograph?
16. Why is the equatorial belt a region of low pressure?
17. What are the pressure belts?
18. What causes a wind?

### *★Optional Exercises*

19. Show by the use of a funnel, a bottle, and some water that a bottle of air is not empty.
20. How much is the air pressure on a human being? What force would the air exert on a person whose surface area is 10 square feet?
21. Explain how a barograph works.
22. How can the barometer be used to determine altitude?
23. Explain the use of the barometer in weather forecasting.

## CHAPTER XXVI

### WINDS

**328. How are winds started?** The atmosphere is heated most over the equator, and therefore it expands most there. Referring to Fig. 254, the expanding air produces a ridge.

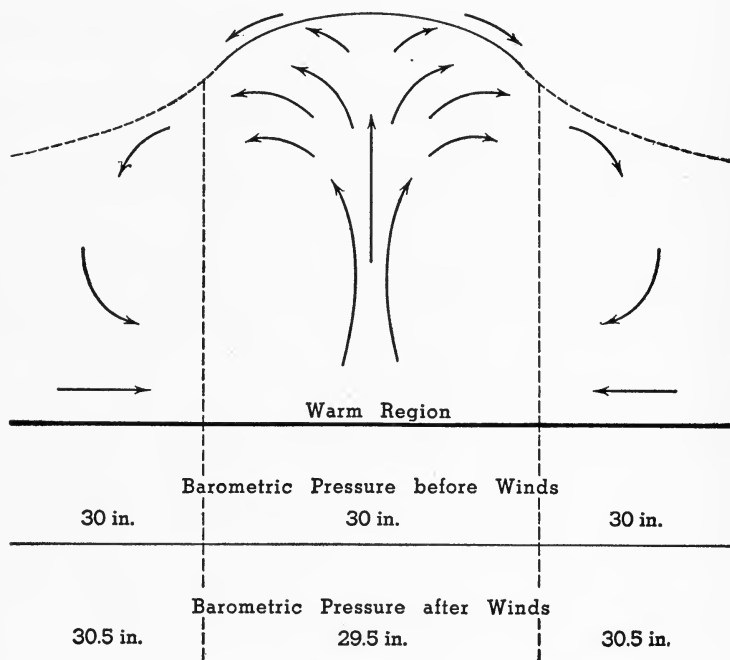

FIG. 254. Cause of Winds

over the equator, like a huge wave, and this ridge tends to flatten out, by a movement of air in the upper regions of the atmosphere, in directions *away* from the heated region, that is, toward the poles. This adds air to these

cooler regions and *increases* their barometric pressure, while it *decreases the pressure over the equator*. The difference in pressure, or pressure gradient, between the cooler and warmer regions causes a movement of air along the earth *toward the equator*. Considering only this one factor, the circulation of air on the earth, like the convection currents in a room, are shown in Fig. 255.

*Winds are horizontal movements of the atmosphere close to the earth*. We distinguish between winds and vertical movements of the air, or movements in the upper layers of the troposphere, both of which are called *currents*.

**329. Terrestrial winds.** The upward movement of the air

in the equatorial regions makes it a belt of *equatorial calms* or light winds, called the *doldrums*. The winds which blow from the horse latitudes, or belts of high pressure, toward the equator are the *trade winds*. Beyond the trade-wind belt in each hemisphere, we have a belt of *prevailing westerlies* (Fig. 256).

This atmospheric circulation for other planets of the solar system must be the same as it is for the earth, since the conditions that bring about our winds are the same on all the planets. On this account those winds are sometimes called *planetary winds*.

**330. Deflection of winds due to earth's rotation.** If the earth did not rotate, the wind system would be very simple, as already shown. But the rotation causes deflection of the trade winds, so that, instead of coming from the north, they seem to come from the northeast, and, in the southern hemisphere, from the southeast.

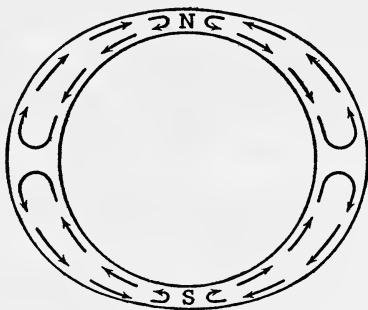

FIG. 255. Circulation of Air in the Earth's Atmosphere As It Would Be if It Were Caused by Convection Alone

Let us try to explain this. These winds arise from the movement of air along the earth toward the equator, so that they ought to be *north and south winds*. The air, as well as the earth, is in rotation around the earth's axis. At the equator the circumference of the earth is about 25,000

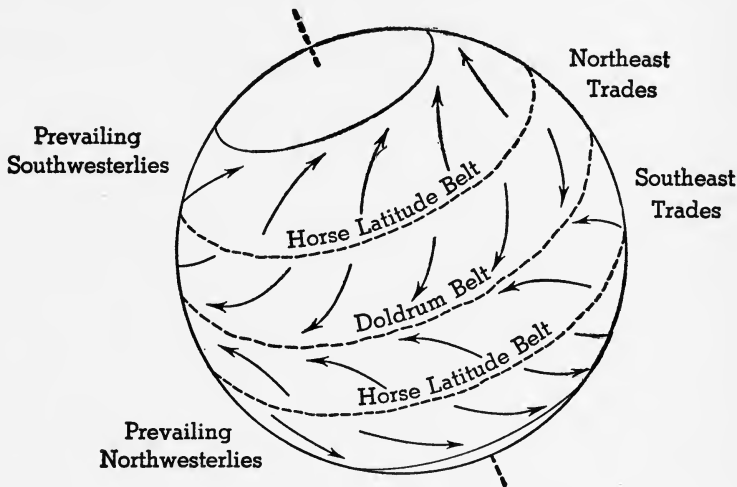

FIG. 256. Terrestrial Wind Belts

miles; and since this rotates once every 24 hours, points on the equator, as well as the air, are moving about 1,000 miles per hour. At the poles this motion is zero; and at intermediate points it is less than 1,000 miles per hour.

Let us follow a trade wind in the northern hemisphere from the horse latitude to the equator. Let us assume that the earth *and the air* move 500 miles per hour. As the air moves south it continues also to rotate 500 miles per hour, *from west to east*. As it moves south it passes over land which is moving *more than 500 miles per hour*, so that the wind falls behind or the earth gets ahead. The result is, as shown in Fig. 257, that a wind starting south from *A* to *B* on the earth's surface will take the apparent direction *A'B'*, because *B* has moved ahead faster than the air. The trade wind, then,

instead of being a north wind, becomes a northeast wind. In the southern hemisphere it is a southeast wind.

This is often stated as follows: in the northern hemisphere a wind will be deflected to the *right of its straight course*, and in the southern hemisphere, to the left. This is known as **Ferrel's Law**.

In the northern hemisphere, then, following the trade wind in its path toward the south we find that it is deflected to the right or west, and hence seems to come from the northeast, which gives it the name: *northeast trades*. The planetary winds are shown in Fig. 256.

The prevailing westerlies which, in the northern hemisphere, are southwesterlies, get their direction as follows. From the horse latitude or region of high pressure, the air moves toward the equator and poles. The air moving south becomes the trade winds, as we have seen. That which moves north toward the pole is rotating from west to east, and as it moves north it moves over land which is not rotating as fast as it is. It therefore gets ahead of the earth, more to the east, and seems to be coming from the southwest. It has been turned to the right of its straight course. Hence they are called the prevailing southwesterlies in the northern hemisphere and the prevailing northwesterlies in the southern.

It therefore gets ahead of the earth, more to the east, and seems to be coming from the southwest. It has been turned to the right of its straight course. Hence they are called the prevailing southwesterlies in the northern hemisphere and the prevailing northwesterlies in the southern.

**331. Description of the wind belts.** The wind belts depend upon the pressure belts; and these in turn are determined by the distribution of temperature. Since the temperature belts shift, in like manner the pressure and wind belts shift.

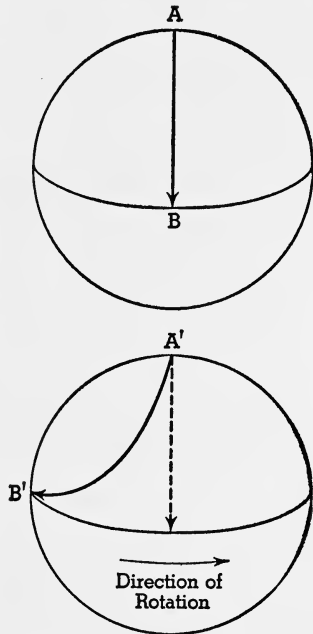

FIG. 257. Ferrel's Law

The doldrums are named because of the light winds and calms that characterize this belt. It is a belt of high temperature and consequently low pressure. The winds move obliquely in toward the doldrums from north and south. Movement of air in the doldrum belt is chiefly upward. Hence it is a belt of calms. The trade winds blow obliquely in from north and south *toward* the doldrums. They derive their name from the fact that sailing vessels in bygone days made use of the regularity of these winds, which blow continuously and always in the same direction. Trade followed these winds.

In the northern hemisphere they are called the northeast trades and in the southern, the southeast trades. They have their origin in the high-pressure belts of the horse latitudes and move toward the low-pressure belt of the doldrums.

Instead of following the steepest gradient directly north and south, as they would do if there were no rotation, they are deflected, in accordance with Ferrel's Law, to the right, in the northern hemisphere, and to the left, in the southern.

The *horse latitudes* are belts of high pressure between the trade-wind belts and the westerlies. It is there that the air, which has risen over the equator, starts to fall toward earth. The horse latitudes are belts of high pressure and air moves away from them toward the equator and also toward the poles. Since the air movement is chiefly downward, the winds along the earth are relatively calm, irregular in direction, and unsteady in duration.

The *prevailing westerlies* flow away from the horse latitudes toward the poles but are deflected to the east by the rotation of the earth. Hence they seem to come from the west and they are called *westerlies*. They are not so constant in their direction nor in their duration as the trades.

★As the prevailing westerlies approach the poles, a *circumpolar whirl* develops. They spiral around the North Pole in a counter-clockwise direction and about the South Pole in a clockwise direction.



As a result of this whirl it is believed the polar regions are areas of low pressure.

Because of excessive cooling of the northern continents in winter, the North Atlantic and North Pacific oceans are warmer than the continents and are therefore *centers of low pressure*. About these centers the winds spiral, like the circumpolar whirl, and from these secondary centers winter cyclones are projected. Those from the Pacific often move southeastward into Canada and the United States.

**332. Shifting of the wind belts.** The pressure belts and wind belts follow the shifting of the heat equator. As a result, places near the borders of the various wind belts lie sometimes in one belt and sometimes in another. Southern Florida, southern California, and northern Mexico are in the horse latitudes in winter and in the northeast trades in summer; and the Panama Canal Zone is in the doldrums in summer and in the northeast trades in winter. The Amazon Valley, usually in the doldrums, is sometimes swept by the trades.

**333. Land and sea breezes.** Since land heats up faster than water, an area of low pressure is developed over the land during the daytime, and a wind will blow from the sea to the land (Fig. 258). This is a *sea breeze*. In the night time this condition is reversed and a *land breeze* blows from the land to the sea.

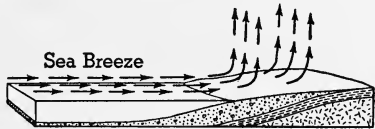

FIG. 258

Advantage is taken of this change of breeze by fishing and pleasure craft that depend upon sails, to carry them away from land at night and bring them back during the day. Similar land and *lake breezes* are felt along the shores of our great lakes and inland seas.

If the land should remain colder than the water throughout the 24 hours, there would be a continuous land breeze. This often happens in winter, especially when the land is covered with snow.

On the other hand, in midsummer it sometimes happens that the land does not cool down, during the night, below the temperature of the neighboring body of water. Then the sea breeze continues throughout the night.

**334. Mountain and valley breezes.** Winds similar to land and sea breezes develop on mountains, particularly at night. The mountain mass cools rapidly at night, and the air in contact with it becomes cool and flows down the slope into the valley. This is a *mountain breeze*.

In the daytime the reverse holds good. The mountain is heated first and a convection current starts *up* the slope. But this current is not so noticeable as the mountain breeze, which is aided by gravity.

**335. Continental air drifts.** Land and sea breezes on a continental scale are called *continental winds*. They are usually so easily obscured by the prevailing winds as to be scarcely noticeable except by their effects on the prevailing winds.

Thus, on our western coast the westerlies are weakened in winter because the land is colder than the water, causing a land breeze, which moves *toward* the west and hence weakens the westerlies, which move toward the east. In summer the continental wind *strengthens the prevailing westerlies*.

On our eastern coast these conditions are reversed, and the winds are *strengthened in winter* and *weakened in summer*.

**336. Monsoons.** Some continental winds are strong enough to reverse the *prevailing winds* at some season of the year. Such winds are called *monsoons*. While many regions have monsoon winds, they are best developed over the northern Indian Ocean and the adjacent lands to the north and east.

During the winter the winds move from the cold mountainous area out over the Indian Ocean, strengthening the prevailing northeast trades (Fig. 259). This is the winter monsoon. During the summer, on the other hand, the sea

breeze off the Indian Ocean *reverses the prevailing northeast trades* into a southwest wind. This is the summer monsoon (Fig. 260).

All continents show some tendency to develop monsoons

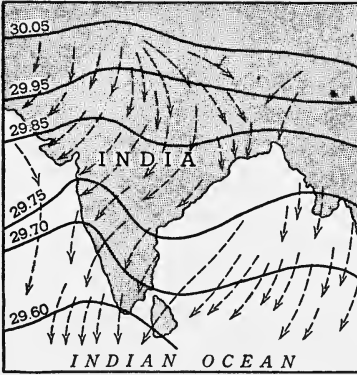

FIG. 259. Winter Monsoon over the Indian Ocean, Showing Isobars

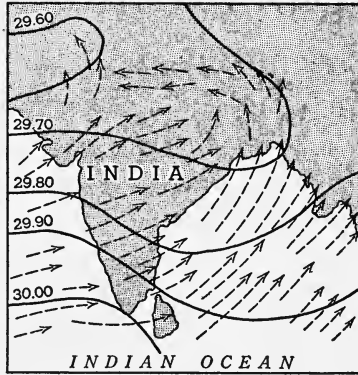

FIG. 260. Summer Monsoon over the Indian Ocean, Showing Isobars

— China for example; but in most cases the effect on the prevailing winds is not sufficient to reverse their direction.

**337. Cyclonic winds.** In temperate latitudes, by far the most important winds are those which are *not regular*, and

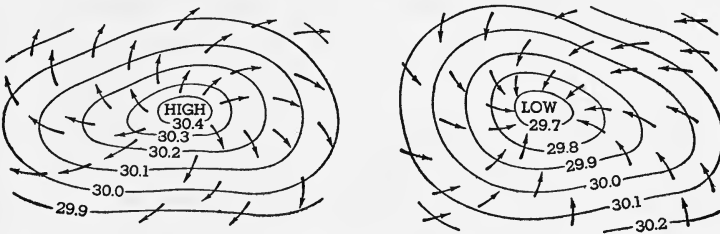

FIG. 261. Isobars about a High and a Low in the Northern Hemisphere

The arrows show the direction of the wind — from high- to low-pressure areas. This direction is clockwise for the high and counterclockwise for the low.

which are caused by the irregular distribution of pressure in *lows* and *highs* (Fig. 261). These are known as *cyclonic winds*. More particularly, the low-pressure area develops a *cyclone*; the high, an *anticyclone*.

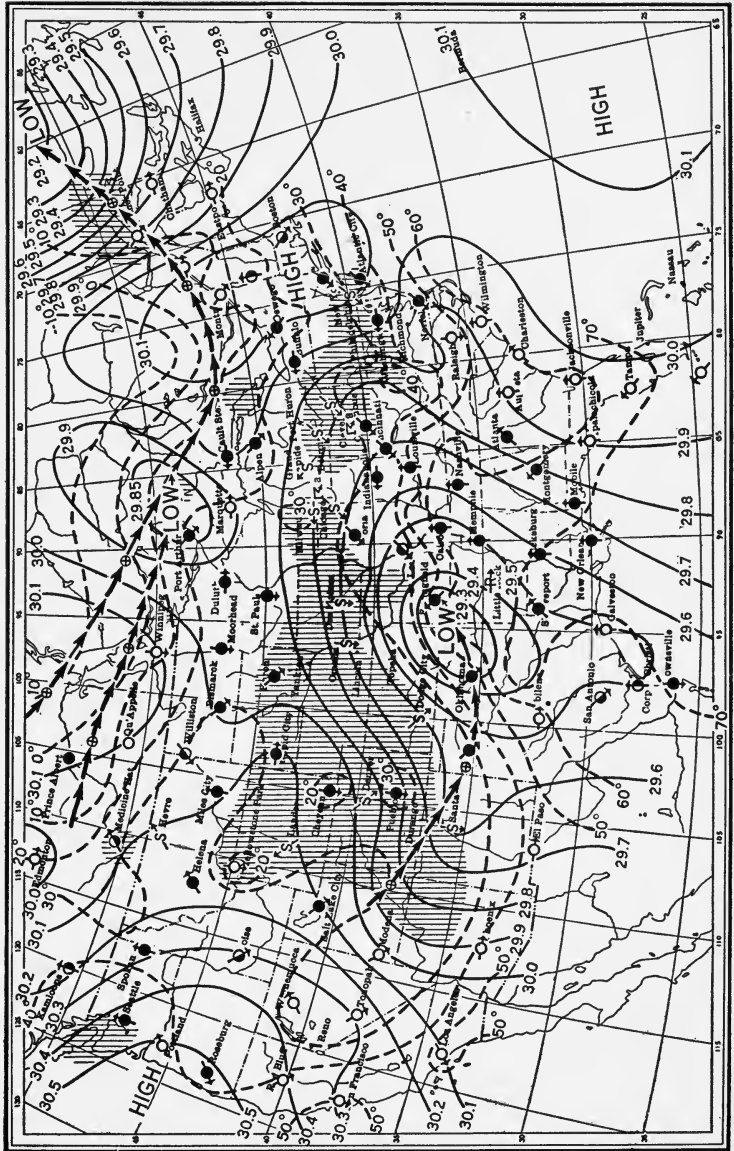

Fig. 262. A Weather Map, Showing the Succession of Highs and Lows

The wind in a cyclone, or low, moves obliquely in toward the center of the low, spiralling about the center in a counter-clockwise direction in the northern hemisphere. In anticyclones, or highs, the winds move spirally out from the center in a clockwise direction.

★Although their origin is not well understood, these cyclonic whirls are now believed to be the result of friction between the

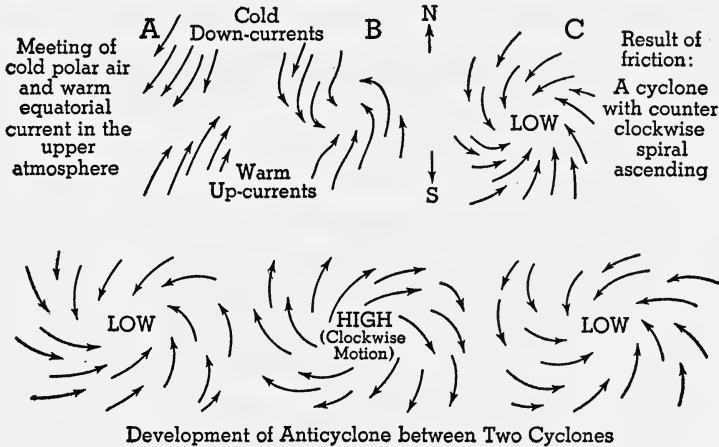

FIG. 263. The Bjerknes Theory of the Origin of Cyclones

great masses of cold air moving from the poles toward the equator, and the warm air moving toward the poles. Somewhere these must pass each other and as they do, the whirls are started.

Referring to Fig. 263A, the cold polar air is deflected to the west as it moves south, while the warm equatorial current, moving north in the upper atmosphere, is deflected to the east as shown, according to Ferrel's Law. Somewhere in the upper atmosphere these must come into contact and the friction between the two, on their edges, causes the whirl shown in B. The warm air ascends inward and we have a cyclone, as shown in C.

Between two lows there must be a high-pressure area developed, as shown in the lower part of Fig. 263, with the down moving cooler air, or high, at the center.

These anticyclones may originate in the higher currents and sink to the bottom of the air fully developed.

**338. Movements of cyclones.** Four distinct movements of air in lows must be noted.

1. Oblique movement toward center
2. Upward movement near center
3. Spiral outflow above
4. Eastward movement of the low itself

Most cyclones follow the general direction of the westerlies. In the United States there are three general paths.

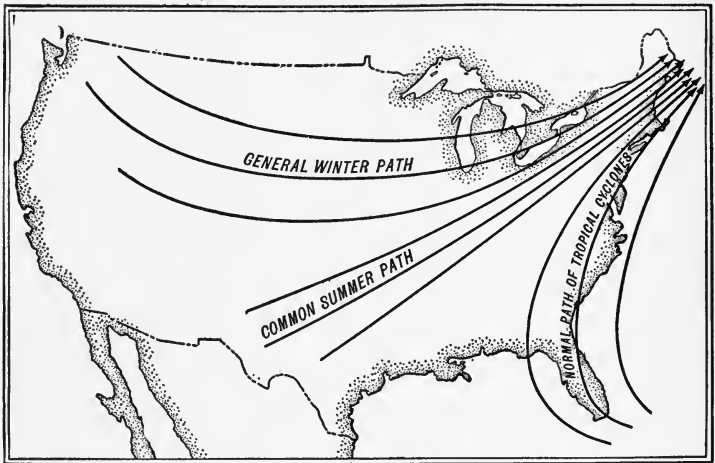

FIG. 264. Paths of Lows in the United States

Those originating in the northwest move southeast until they reach the Mississippi and then move northeast (Fig. 264). Those having their origin in the southwest move systematically northeastward across the continent.

Tropical cyclones having their origin in the region of the West Indies move first northwestward until they reach the horse latitudes or region of high-pressure calms, then northeastward in the westerlies. They usually cross the high-pressure belt near the land, where the high pressures are not so well developed.

All cyclones sooner or later conform to the course of the prevailing westerlies.

**339. Velocity of cyclonic winds.** The velocity of cyclonic winds averages about 10 miles per hour, being a little more in winter than in summer. In the higher layers of air it may be as high as 45 miles per hour. The velocity increases near the center of the low; and if a strong spiral movement is developed, the velocity is greatly increased.

In the anticyclone, the wind velocity is least at the center. Consequently the strength of the wind increases with the approach of a low and decreases with the approach of a high.

When the low-pressure area is very small, often less than 100 feet, the spiralling winds may attain a velocity as great as 100 miles per hour and become destructive. Such wind storms, with velocities more than 100 miles per hour, are known as *tornadoes*. Similar but larger storms in the West Indies are called *hurricanes*, and in the East Indies, *typhoons*.

Hurricanes often attain a velocity of 60 miles an hour, with diameters of 100 miles or more. The smaller the area of the storm, the stronger the wind, because the pressure gradient is steeper.

The term cyclone is often incorrectly used for especially strong winds; but in reality it may be a gentle breeze of four miles per hour, or a driving gale of 40 miles per hour. A cyclone is simply a low-pressure area, and the winds circulating around it may have *any* velocity.

★Cyclones of wide extent, within the tropics, sometimes have an area of clear skies within the whirl of destructive winds. This area, called the *eye of the storm*, may have as much as one tenth of the diameter of the cyclonic area. Vessels passing through the eye of the storm experience equally strong winds in the front and in the rear of the cyclone, though from opposite directions.

**340. Thunderstorms and tornadoes.** In summer, after a day or so of excessive heat, the rapid convectional ascent of the air about a low may set up locally a more limited, though more intense, cyclonic whirl. The rapid condensation of vapor in the rising and cooling air may give rise to,

or be accompanied by, brilliant displays of lightning and heavy thunder. Such storms are known as *thunderstorms*. Torrential downpour of rain may follow quickly after the most brilliant discharges of lightning, but it is a notable fact that the lightning flashes become rapidly less frequent after the rain begins to fall.

Thunderstorms are usually summer and daytime phenomena and they seldom occur in winter or at night. They

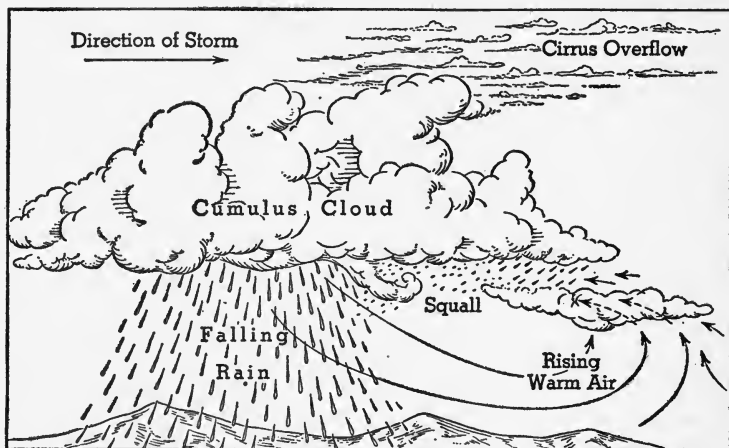
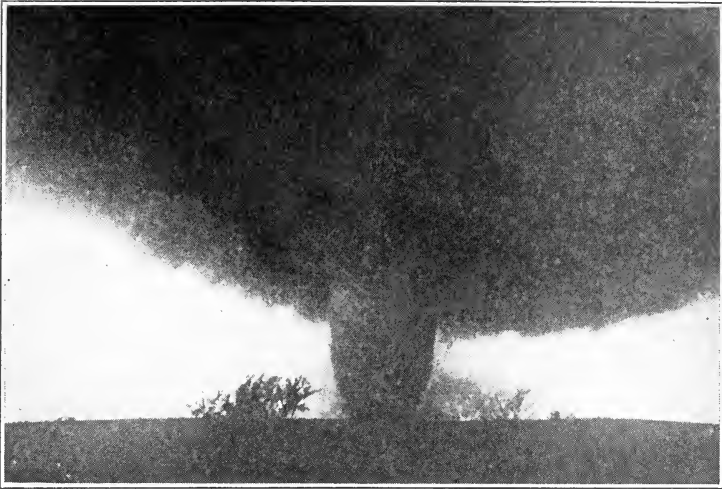

FIG. 265. A Thunderstorm in Front of a Low

are much more common in front of lows than behind them. In the United States they occur most frequently in the southeastern quadrant of the low-pressure area (Fig. 265).

If the local whirl thus developed is destructive in violence, it is called a *tornado*. The destructive path of a tornado is rarely a mile in width and usually but a few miles in length; more commonly it is but a hundred yards in width (Fig. 266). Within that narrow path, the violence of the wind is such that few structures above ground are strong enough to withstand it. In those states in the Middle West where tornadoes are most frequent, underground structures called "cyclone cellars" are built. These seem to offer the greatest security from danger.





*Wide World*

FIG. 266. Photograph of a Tornado near Oklahoma City, Oklahoma

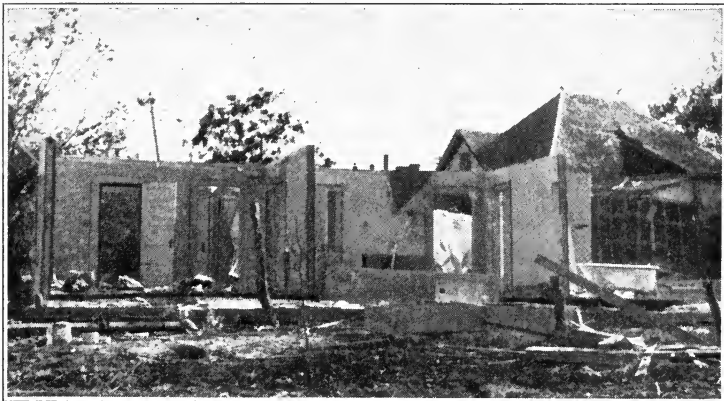

*Underwood & Underwood*

FIG. 267. What the Same Tornado Did in Texas

★The destructive effect of the tornado on buildings seems to be the result of the exceedingly low pressure at the center of the cyclone. The air inside the house is at normal atmospheric pressure; and this is so much greater than the low pressure in the tornado that it pushes the roof and walls out (Fig. 267).

If we assume the pressure in the whirling air to be only 1 lb. per square inch less than that in the house, and the house to be a box 20 ft.  $\times$  30 ft.  $\times$  25 ft., a force of about *half a million pounds outward* would be developed.

★341. **Shifting of winds.** When a place lies near the path of a low or high, the winds at that place will shift in a systematic way as the barometric disturbance passes. In the westerlies of the northern hemisphere, where cyclones and anticyclones follow each other across the continent from west to east, the shifting of the winds is shown in Fig. 268.

If a low passes *directly* over a place, the winds will start as an east wind as the low approaches and change suddenly to a west wind as the low passes off to the east. It is just the reverse for a high.

★342. **Special winds.** In every part of the world, winds of special character and of exceptional occurrence are known, and local names given to them.

Among *warm winds* may be mentioned:

1. *The hot wave.* This blows from the west or southwest over western central United States, sometimes continuing for days and withering all vegetation.

2. *The sirocco.* A south wind from the Sahara Desert, felt as far as the north shore of the Mediterranean Sea. It is usually dry and dust-laden.

3. *The simoon.* An intensely hot, dry, sand-laden wind of the Arabian Desert. It is probably a convectional whirlwind, similar to the dust-laden whirlwinds of all dry, hot climates. It lasts usually less than 10 minutes, and often forms sand spouts.

4. *The chinook.* An American wind, which moves down the slopes of mountains toward a low-pressure area at their base. Though starting as a cold wind, it gets warmer by compression in its descent, and if the mountain is high, it may reach the base as a warm or even a hot wind.

In all cases, because of its dryness, it evaporates or melts the snow fields over which it blows and often causes destructive avalanches by melting the snow on the steep slopes.

It is of frequent occurrence along the eastern bases of the Sierra Nevada and Rocky Mountains. Many valleys here are kept practically free of snow, and their temperatures are so mild as to make

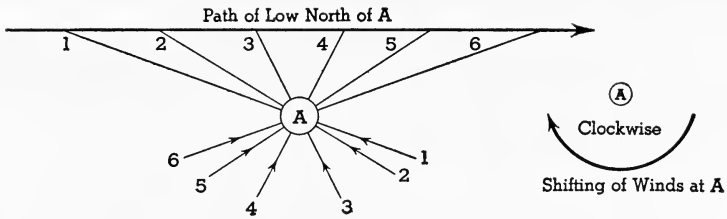

A. When the low is at 1, the wind blows from the southeast toward A. As the low moves east, the winds shift, as shown, to the southwest.

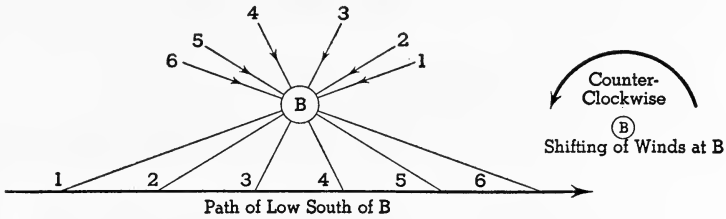

B. In this case, the wind starts from the northeast and shifts to the northwest.

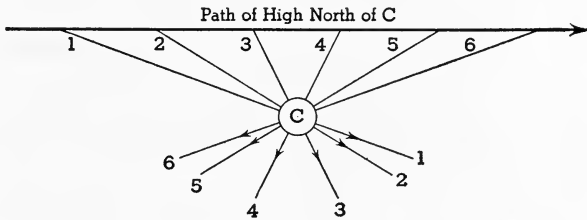

C. By means of a curved arrow, show how the winds shift in this case.

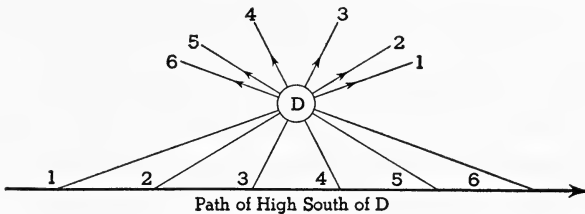

D. By means of a curved arrow, show how the winds shift in this case.

FIG. 268. Shifting of Winds in Cyclonic Storms

shelter for stock, in winter, unnecessary and to permit grazing throughout the year.

The chinook is scarcely noticeable in summer.

5. *The foehn*. This is the European chinook, common on the northern slopes of the Alps, where in the north-south valleys it hastens the ripening of grapes in the fall, and in winter rapidly melts the snows in its path. This has earned for it the name *snow-eater*.

To the class of *cold winds* belong:

1. *The norther* of southwestern United States. It is the cold inflow of winds from the north at the rear of the winter cyclone. A fall of temperature of  $50^{\circ}$  in two hours has been noted. These winds

often cause great suffering, loss of livestock, and even loss of human life.

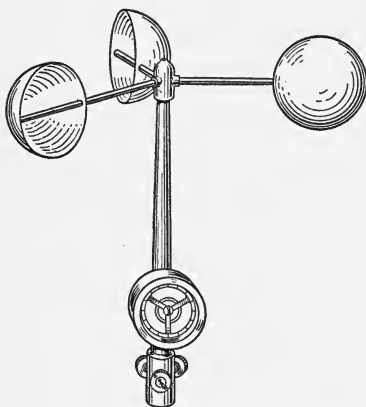

FIG. 269. An Anemometer

2. *The blizzard*. The American name for a cold wind of high velocity, accompanied by snow. Winds of 50 miles an hour have been noted in blizzards with temperatures below zero. The blizzard begins with a cyclonic storm during which snow falls. This is followed by an anticyclone which brings rapidly falling temperatures from the northwest. It may not actually be snowing at the time, but the wind blows up

the snow from the ground, producing what seems to be a blinding snowstorm.

3. *The bora*. A cold wind in the territories of Istria and Dalmatia.

4. *The mistral* comes from the northwest and cools the coast of southern France, particularly around Marseilles.

**343. Velocity of winds.** Wind velocity is measured by an instrument called the *anemometer* (Fig. 269).

Approximate estimates of wind velocity may be made by means of the following table:

WIND	DISTINCTIVE CHARACTERS	VELOCITY IN MILES PER HOUR
Calm	Flags limp; leaves unmoved.	0
Light breeze	Moves leaves on trees.	1-5
Fresh wind	Moves branches of trees; blows up dust.	5-15
Brisk to strong	Sways branches of trees; makes whitecaps.	15-25
High wind	Sways trees; moves twigs on ground.	25-35
Gale	Breaks branches; dangerous sailing.	35-75
Hurricane	Destroys houses; uproots trees.	75-100

### *Completion Summary*

Winds move from \_\_\_\_\_ to \_\_\_\_\_ pressure areas, \_\_\_\_\_ earth. Movements of air \_\_\_\_\_ or \_\_\_\_\_ are called currents.

The doldrum belt is a region of \_\_\_\_\_ winds. The winds that blow from the region of high pressure or \_\_\_\_\_, toward \_\_\_\_\_ are called \_\_\_\_\_. Between these and the poles are \_\_\_\_\_. Instead of moving north and south, these winds are turned \_\_\_\_\_ in the \_\_\_\_\_ and \_\_\_\_\_ in the southern hemisphere. This is known as \_\_\_\_\_ Law.

\*In winter the land masses in the northern hemisphere are \_\_\_\_\_, and the oceans \_\_\_\_\_ cyclones, which move \_\_\_\_\_ into the United States.

The apparent movement of the sun, north and south of the equator, causes a corresponding movement of \_\_\_\_\_ equator, which changes somewhat \_\_\_\_\_ belts. These changes affect the \_\_\_\_\_ in the United States.

A sea breeze is developed when the land \_\_\_\_\_ and the air pressure, there, \_\_\_\_\_ than that over the water. This is usually \_\_\_\_\_ at night, starting \_\_\_\_\_ breeze. For the same reason, \_\_\_\_\_ and valley breezes are started.

On a continental scale, these breezes become \_\_\_\_\_ and if they are strong enough \_\_\_\_\_ prevailing winds, \_\_\_\_\_ monsoons.

In the temperate zone, the most important winds are \_\_\_\_\_. The spiral movement of air, in a low, is turned

———, in a —— direction. In a high, called an ——, the winds move in —— direction.

★One theory of cyclones explains them as follows: friction between —— and —— starts the whirl.

A succession of highs and lows moves across the United States from —— to ——.

Cyclonic winds —— velocity; but it is always —— at the center. Anticyclones have —— at the center. When velocities are high, they are called —— or ——.

In summer a cyclonic wind may develop into a ——, in which —— is accompanied by —— and ——.

★The destructive effect of tornadoes on buildings is due to —— pressure —— . The difference of pressure —— great force which pushes ——.

When a low or a high passes near a place, there is a regular shifting of ——, in every case due to movement of the air from —— pressure to ——.

A hot wave, in the United States, blows —— and —— for days.

The chinook is a —— breeze which becomes —— as it descends and has a beneficial effect on the climate of the valley.

A norther is —— wind, met in winter in —— United States.

A blizzard —— high wind with ——.

### *Exercises*

1. Show by diagram the relation between barometric pressure and temperature.
2. What is a wind?
3. How is a wind started?
4. How do air currents differ from winds? In what way are they alike?
5. Where are the doldrums? Why are they situated there?
6. Where are the horse latitudes?
7. What are the trade winds? Explain how they arise.
8. Where are the prevailing westerlies?
9. Why are these winds called planetary winds?

10. Explain the direction of the northeast trade winds.
11. Explain Ferrel's Law.
12. Explain the direction of the prevailing southwesterlies.
13. Explain the connection between high temperature and low pressure.
14. Explain the calm winds of the doldrum belt.
15. Why are the trade winds so called?
16. Explain the direction of the prevailing westerlies.
17. Why do the wind belts shift? What effect has this on the United States?
18. What is a sea breeze? a land breeze? What causes them?
19. Why does a sea breeze sometimes continue to blow throughout day and night?
20. How does a mountain breeze develop? Why is it stronger than a valley breeze?
21. What are continental winds?
22. What effects have the continental winds of the United States on the prevailing westerlies?
23. What are monsoons? Where are they well developed?
24. Do we have monsoons here? Explain.
25. How do the winds move in a cyclone? an anticyclone?
26. What is the general direction of movement of cyclones in the United States? Why?
27. What is the average velocity of a cyclonic wind? In what part of the low is the velocity greatest?
28. Why does the wind velocity decrease with the approach of a high?
29. What are tornadoes? Why are they destructive?
30. What are hurricanes?
31. What are typhoons?
32. Why is the wind stronger when the area is smaller?
33. What is a thunderstorm?
34. What are cyclone cellars?
35. What is an anemometer?

**★Optional Exercises**

36. Explain the irregularity of winds in the horse latitudes.
37. Why are summer days more apt to be windy than summer nights? than winter days?

38. Why are winter winds stronger than summer winds?
39. What is the source of winter cyclones in the United States?
40. Explain how cyclones develop their counterclockwise rotation.
41. What is the source of tropical cyclones? What path do they follow?
42. Why do thunderstorms rarely occur at night or in winter?
43. How do the winds shift as a low approaches and passes north of a given place?
44. How do the winds shift as a low passes south of a given place?
45. How do the winds shift as a high passes north of a given place?
46. How do the winds shift as a high passes south of a given place?
47. What is a hot wave? a blizzard?
48. What is a norther? the chinook?



## CHAPTER XXVII

### MOISTURE OF THE AIR

#### CLOUDS, SNOW, AND RAIN

**344. Humidity.** There is always a certain amount of water vapor in the air, which we call *humidity*. When it is small, we say the air is *dry*; when there is much humidity, we say the air is *moist* or *muggy* or *close*, particularly in summer. The water vapor manifests itself in various ways: by collecting as dew or frost on grass, by fog, clouds, rain, and snow. Very many of the changes involved in *weather* are a result of humidity.

The amount of water vapor per cubic foot of air is called the *absolute humidity*. This might be 10 grains per cubic foot. In that case, the water in a moderate-sized room would weigh about 3 pounds.

If more moisture is evaporated, the absolute humidity will increase, but finally the air will take no more; it *has enough*, it is satisfied or *saturated*, as we say.

Suppose, again, the absolute humidity is 10 grains per cubic foot and that the same air *could hold at saturation*, 20 grains per cubic foot. It is therefore half, or 50%, saturated. Usually we express this by saying: *the relative humidity is 50%*. For human comfort, about 50% relative humidity at 68° F. is best. Plants thrive at about 75% relative humidity. We call the air *dry* when it has 25% or less relative humidity, and *moist* above 75%.

If the temperature is raised, the air can hold more moisture. If, then, the absolute humidity at 68° F. is 3 grains per cubic foot, and the air at that temperature could hold 6 grains per cubic foot, it has 50% relative humidity. If the temperature of that same air is raised to 86° F., it *could* hold

12 grains per cubic foot, but only holds 3, and its relative humidity, therefore, has dropped to 25%.

Raising the temperature, then, decreases the *relative humidity* (not the absolute humidity), and lowering the temperature increases the relative humidity.

**345. Dew point.** We have just seen, in the last paragraph, that *cooling the air will increase its relative humidity*. Could the relative humidity be increased to 100% by cooling? The best way to answer that would be by a simple experiment (Fig. 270). Place some water in a metal container, add small pieces of ice, and stir gently with a thermometer. As soon as dew forms on the outside of the metal, read the thermometer. *This is the dew point.* It is 40° F. in the figure.

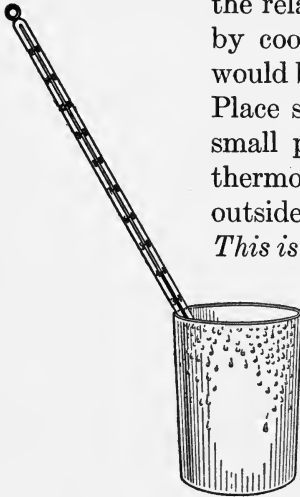

FIG. 270. Finding the Dew Point

What has happened in this experiment? The air contained moisture; and as the temperature of the metal was lowered, it cooled the air immediately about it, increasing its relative humidity. When the relative humidity reached 100%, the *air could hold no more moisture*. From that point any

further cooling would squeeze moisture out of the air, since the air could hold no more. This is the dew point.

*The dew point is that temperature to which the air must be cooled in order to cause moisture to settle out.* If the entire air were cooled to the dew point, it would rain.

If the dew point is below 32° F., then we have *frost* instead of dew; and if the entire air is cooled to that point, we get snow.

The dew on objects out of doors, at night, is formed because they radiate heat and drop in temperature. At the dew point, water or dew is precipitated on them. It does not rain, because the temperature of the *entire* air, while it may drop at night, does not fall below the dew point.

**346. Evaporation and condensation.** Evaporation takes place from all moist surfaces and is increased by heat. Even ice evaporates, but much more slowly than water. It requires much heat to cause water to evaporate, and therefore, in evaporating, water absorbs heat from the surface. Swimmers sometimes say that it is warmer *in the water* than in the air. This is true when a wind, especially a dry wind, is blowing, because the evaporation caused by the dry wind takes much heat from the wet skin. Moving air causes more rapid evaporation than still air, because the air above the wet surface may become saturated and prevent further evaporation; but when this saturated air is removed, more water can evaporate. Evaporation is more rapid when the relative humidity is low.

All animals and plants evaporate water. It is estimated that a tree gives off 500 pounds of water on a hot day.

All the moisture of the air comes ultimately from the oceans, to which it again returns, so that there is a great *cycle of water in nature*.

*Condensation* is the opposite of evaporation. It is increased by lowering the temperature. When the air is saturated, 100% relative humidity, any further lowering of the temperature causes *condensation* to a liquid or solid; liquid if the air is above 32° F., and solid if it is below.

The cooling which causes condensation may result from:

1. *Loss of heat by radiation from air to land or water.* In the lower air, fogs are caused in this way.

2. *Contact of air with cold surfaces.* Dew and frost are formed in this way.

3. *Mixing of cold and warm currents of air.* Clouds, fogs, or rain may be caused in this way.

4. *Cooling by expansion.* This is true of ascending air currents and is *the chief cause of cloud formation and rain*.

We all know that cold contracts and heat expands. It takes heat to expand air, just as it does to evaporate water,

since that is a kind of expansion, too. And if the air is forced to expand *without* adding heat, its temperature will drop.

When air currents are rising, then, they are expanding because of lower pressure aloft, and therefore cooling; and when the dew point is reached, condensation takes place.

When air *descends*, it is compressed and becomes warmer; hence its relative humidity drops.

The doldrum belt, the region of lows, and the windward slopes of

mountains, where air currents are rising, are apt to be rainy, while the region of highs and the leeward slopes of mountains, where air currents are descending, have clear skies.

**347. How to find relative humidity.** Women often complain that their hair straightens out in moist air. This principle is made use of in the hair *hygrometer*, an instrument in which a hair increases its length when the air is moist. The dial of the hygrometer reads *the per cent of relative humidity* (Fig. 271).

Another method is by use of the *sling psychrometer* (Fig. 272). This consists essentially of two thermometers, mounted so that they can be swung around. One thermometer has a piece of wet cloth around its bulb, while the other is dry. Since evaporation takes up heat, the wet thermometer will register a lower temperature than the dry one; and if it is moved rapidly by swinging it, the evaporation

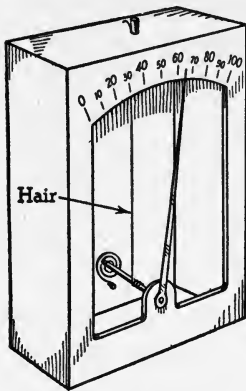

FIG. 271. A Hair Hygrometer

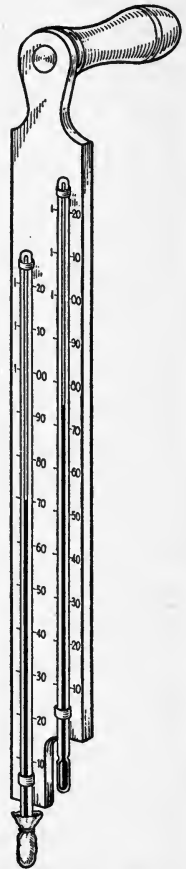

FIG. 272. Sling Psychrometer

will be rapid. If the air is saturated, 100% relative humidity, there will be no evaporation and both thermometers will read alike. If the air is very dry, low relative humidity, there will be rapid evaporation, and the wet bulb thermometer will drop many degrees below the dry. The dry thermometer remains the same in every case — it merely registers the temperature of the air. A large difference between the two thermometers, then, means *low* relative humidity, and a small difference means *high* relative humidity.

By means of a table furnished with the instrument, the relative humidity at any temperature can be determined by the *difference* in the readings of the two thermometers.

**348. Distribution of water vapor.** Since most evaporation takes place at sea level, the lower air is of higher absolute humidity; that is, it contains more moisture. The moist air from the sea areas is distributed by winds and currents throughout the lower air or troposphere. Water vapor, and therefore clouds, are practically confined to the lower six miles of air: the troposphere.

Although there is more water vapor in the lower air, the *relative humidity* is higher at greater altitudes, because of the cooling of the air as it rises and expands. It is this change, then, which causes condensation in the upper air, resulting in clouds and rain.

Relative humidity varies with change of place and also in the same place, from hour to hour. It is highest at the coolest part of the day, usually in the morning, and decreases as the day advances and the air warms up. It is lowest at the warmest hour of the day, from 1.00 to 3.00 P.M., after which it slowly rises.

**349. Dew and frost.** When air is cooled below the dew point by contact with a cold object, condensation takes place upon the cold object. Dew is formed, if the dew point is above 32° F., and frost if below 32° F. Dew and frost *form*; they do not fall. Frost is not frozen dew. Frozen dew becomes transparent beads of ice.

Anything that checks the cooling of the ground and lower air tends to prevent the formation of dew and frost. The ground beneath trees and shrubs is often protected from dew, although it forms freely on exposed ground. A cloudy sky checks radiation and prevents the excessive cooling that forms dew and frost. Likewise wind, by carrying away the saturated air, prevents the deposition of dew or frost, but the cooling is even greater. It is rare to have dew or frost on cloudy or windy nights.

Dew is usually formed on grass, because the grass is giving off much moisture and the relative humidity near the grass is very high.

Fruit trees are often protected from frost by *smudges*. The smoke thus produced hangs over the orchard, checks radiation as a blanket would, and often prevents frost.

When condensation begins, heat is set free, which checks further cooling; so if saturation occurs much above freezing, that is, when the relative humidity is high, frost is unlikely. Housewives often protect their flowers from frost on cold nights by exposing shallow pans of water in the room, in order to increase the relative humidity. As the room cools, condensation takes place and the heat set free may keep the temperature above freezing.

This principle has been applied on a large scale for the protection of orchards, when there is no wind. By spraying water into the air, in and about the orchard, the relative humidity is increased and the dew point raised.

**350. Fog.** When a volume of air is cooled below the dew point, condensation takes place on particles of dust, forming tiny droplets of water or crystals of ice. Without dust, condensation will not take place.

When droplets of water are so small that they float, we have a *cloud*. If it is low enough to reach the land or water, it is called *fog*; that is, *a fog is a cloud at the surface of the earth*.

London fogs, sometimes called "pea soup," are caused by

condensation of moisture from humid air on particles of carbon thrown into the air by the use of soft coal. These fogs are sometimes so thick that traffic must be stopped.

Fogs usually result from warm, humid air passing over cold surfaces. In winter, winds blowing from the sea are likely to produce fogs.

Fogs are more frequent in valleys than on mountains. The cooler, heavier air accumulates in the valley, where there is more moisture, and condensation sets in.

The fogs of the Grand Banks, off the east coast of Newfoundland, are known to all navigators of the North Atlantic. They are caused by easterly winds, moisture-laden, passing over the cold Labrador current. Another cause of much of the Newfoundland fog is the ice brought down from the Arctic by the Labrador current. These icebergs are apt to be centers of dense fogs, especially in summer. These fogs seriously delay and endanger ships passing through them; the ships must reduce speed and often completely stop, with continuous warning signals. They also interfere with transatlantic airplane travel.

Traffic in many harbors is frequently interrupted by dense fogs. Infrared radiation penetrates fog and cloud, and airplane photographs of the earth can be taken by the use of infrared film. A device for transforming infrared into visible light has just been invented, and this will enable the skipper of a vessel to see through the fog.

**351. Clouds** are fogs formed high in the air, but this never happens above 6 miles, because of the absence of water in the stratosphere. As the warm current of air rises from the earth, it expands and cools, and an elevation is reached where the dew point is passed and condensation begins. The dew point at high elevations is often below freezing, so that clouds often contain ice or snow crystals.

Clouds are classified chiefly by their form. The thin, feathery white clouds high in the air, frequently seen on fair days, are *cirrus* clouds. *Cirrus* means curls or ringlets.



U. S. Weather Bureau

FIG. 273. Cirrus Clouds

These filmy clouds are composed of slender crystals of ice called spicules. Their average summer altitude is about 6 miles and they generally move eastward (in the westerlies) at the rate of 60 miles an hour. In winter they move eastward at a height of 5 miles, at about 100 miles an hour.

*Cirrus* clouds are often forerunners of storms. They are due to upward air currents in a cyclone extending nearly to the stratosphere. As the warm air rises, it expands and cools below the dew point, which at that high elevation is about 40° F. Rapid crystallization from the rarefied air produces the tiny crystals of the cirrus cloud and accounts for their being feathery and often transparent. The winds at the high elevation help to draw the cloud out into long wisps.

*Cumulus* clouds are massive piles of clouds with an even base, resembling piled-up fleeces of wool or volumes of condensing steam from a locomotive. They are the result of rising currents of air, and are therefore storm clouds. These clouds, which sometimes are called *thunderheads*, are land clouds, formed by day, and are more commonly in motion than at rest.

The average summer height of cumulus clouds is about a mile and a half, and in winter they are about a mile high.



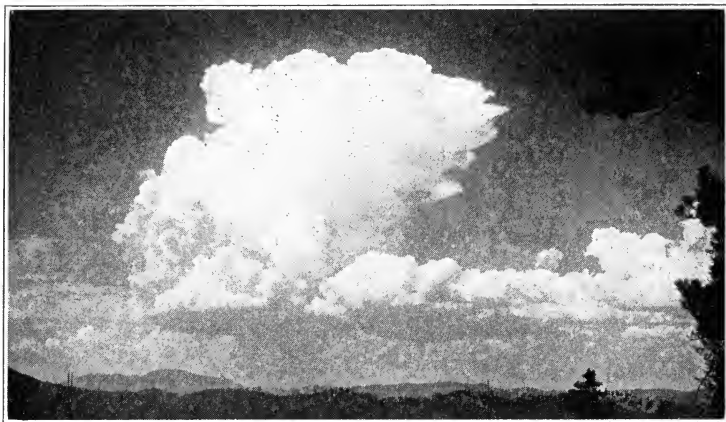

FIG. 274. Cumulus Clouds

*U. S. Weather Bureau*

FIG. 275. Nimbus Clouds

*U. S. Weather Bureau*

Their velocities are from 6 to 9 miles an hour. Their even bases are from a quarter to a half mile above the earth.

*Nimbus* is the name given to any cloud from which rain or snow is falling or may be expected to fall. They are of variable height, usually less than a mile, sometimes only a few hundred feet above the surface (Fig. 275). Nimbus clouds are of an even grayish tint, sometimes completely overcasting the skies for hours and even for days.

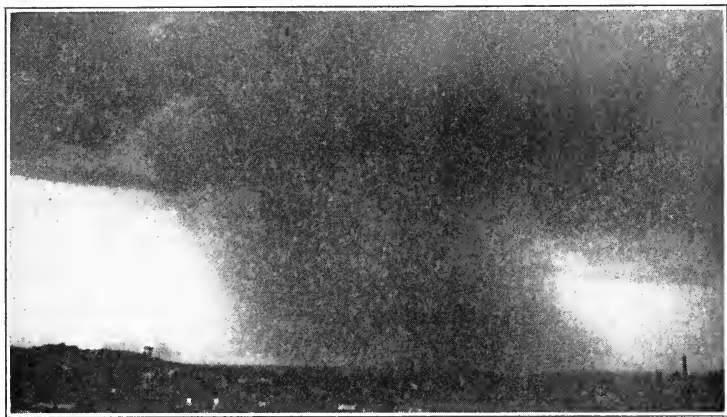
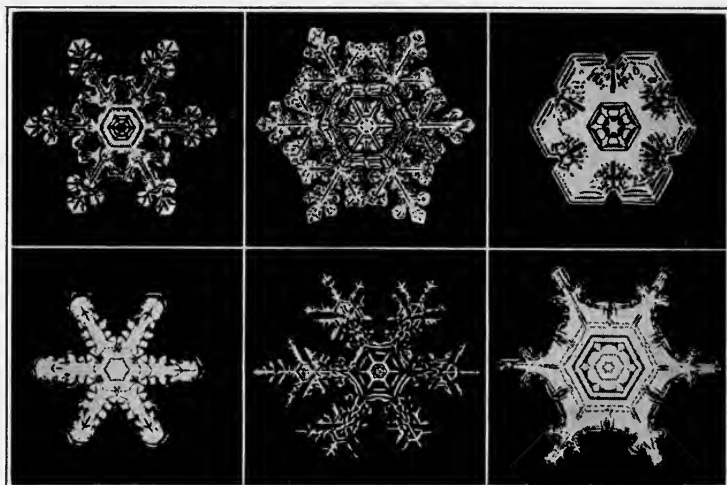

FIG. 276. Snow Crystals

U. S. Weather Bureau

*Stratus* is any cloud, about half a mile high, spread out in parallel layers. It is a night cloud, common over the sea and in valleys. It includes fogs.

Many clouds which do not assume quite one shape or the other of those mentioned are given combination names, like cirro-stratus, alto-cumulus, and cirro-cumulus.

**352. Rain and snow.** We have seen how cloud is formed below the dew point, and we know that from the ordinary cloud we do not get rain. In order to get rain, the cloud particles must grow to such size (called drizzle size) that they will fall in air, and ordinary droplets do not unite on collision, but rebound like rubber balls.

When vertical convection is going on, cloud particles are first formed about dust and other nuclei. This process soon removes the dust and the ascending air is clean, so that no further condensation can take place on such nuclei. There remains nothing but a few *smaller cloud particles*, to rise with the moist air; and further condensation must take place on these, until raindrops are formed. Condensation on fewer particles produces *larger drops*, heavy enough to fall.

This process is called *precipitation*. If it occurs above 32° F., we have rain; if below 32° F., we get snow.

*Snow is not frozen rain.* The water vapor passes at once from vapor to the solid condition. Rain and snow bear the same relation to each other as dew and frost. Snowflakes are crystallized water vapor, built upon patterns resembling beautiful six-rayed stars. Above a certain elevation, called the *snow line*, there is always snow on the ground. In the temperate zone the snow line is about two miles high. In the polar regions it is at sea level.

**353. Hail and sleet.** If raindrops in their fall pass through a layer of air sufficiently cold, they are frozen into bits of ice called *sleet*. As the conditions described are most likely to occur in winter, when the land is colder than the air above it, sleet is a winter phenomenon. *Sleet is frozen rain.*

In summer, especially on a hot afternoon and near the center of a cyclonic storm, large pellets of ice called *hail* often fall. Upon examination, hailstones prove to be made of concentric layers of ice. This structure, together with their often great size, suggests that they are frozen raindrops, enlarged by successive condensations and freezings upon the surfaces. This occurs as follows: In the rising current of air some of the droplets may be carried up to an elevation where the temperature is below freezing. The raindrop is frozen. In the irregular, whirling current, some of these will be thrown to the side, where convection is not strong, and they fall into the lower layers, where condensation on their surfaces wets them. Carried up again by strong air currents, the water is frozen and the process repeated until their size is so great that they can no longer be kept from falling. The velocity of the upward current for one-inch hailstones is about 50 miles per hour, so that such storms are very dangerous for aircraft (Fig. 277).

Hailstorms are sometimes very destructive. Their paths are only a few miles in width and fortunately not of great length; for often, growing crops, orchards, and even forests

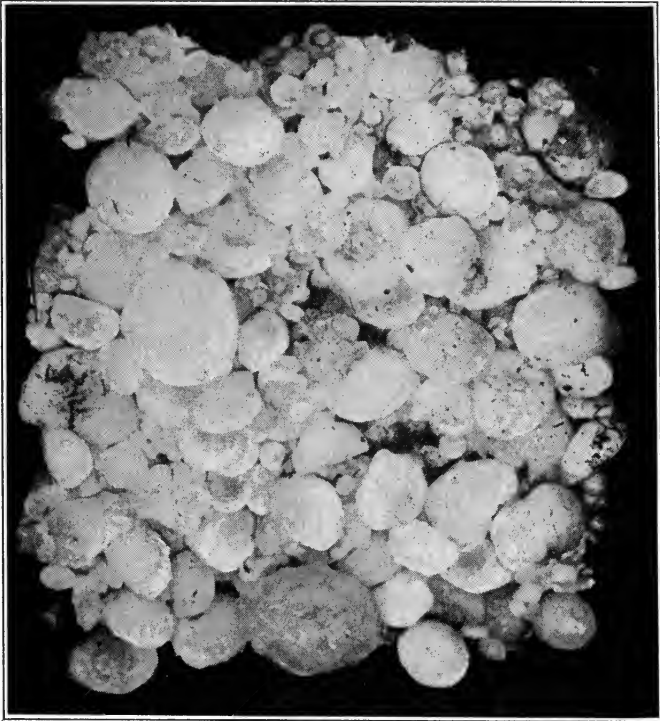

*U. S. Weather Survey*

FIG. 277. Hailstones from Emporia, Kansas

are destroyed. Leaves, bark, and branches are stripped from trees; young animals are killed, and windows and roofs broken by the hailstones, which have been known to be larger than baseballs and even large oranges.

**354. Sheet ice.** Sometimes rain falls in winter, but immediately, upon touching the ground or trees, it is frozen. This occurs when the lower air is just above the freezing point, while the ground and all solid objects near it, being better radiators, have cooled below freezing. This is *sheet ice*. It is popularly though erroneously called sleet.

Sometimes the weight of ice on twigs and boughs is sufficient to break the branches. Telephone and telegraph wires are often broken down by sheet ice.

### *Completion Summary*

Absolute humidity is measured in \_\_\_\_\_ per \_\_\_\_\_. Relative humidity is \_\_\_\_\_% when the air is saturated; is \_\_\_\_\_% when the air is half saturated; and is \_\_\_\_\_% when the air contains one quarter of the moisture it could contain at \_\_\_\_\_. If the temperature is raised without adding more moisture, the relative humidity \_\_\_\_\_. If the temperature is lowered, the relative humidity \_\_\_\_\_ until it reaches \_\_\_\_\_%, after which \_\_\_\_\_ takes place. This temperature is called \_\_\_\_\_. If the dew point is below \_\_\_\_\_, we get \_\_\_\_\_.

It requires heat to \_\_\_\_\_ water. If no heat is added, evaporation will absorb \_\_\_\_\_ and cause a drop in \_\_\_\_\_. Conversely, condensation gives out \_\_\_\_\_.

Fog is condensation on \_\_\_\_\_ in droplets \_\_\_\_\_ settle. Fog in the upper air is called \_\_\_\_\_. Clouds formed very high consist of \_\_\_\_\_ because \_\_\_\_\_ temperature. These are called \_\_\_\_\_ clouds. Cumulus clouds or thunderheads are due to \_\_\_\_\_. Nimbus clouds are \_\_\_\_\_. When cloud particles \_\_\_\_\_, we get rain. If the temperature is below \_\_\_\_\_, we get snow.

Sleet consists of \_\_\_\_\_ rain. Hail is sleet which \_\_\_\_\_.

### *Exercises*

1. What is absolute humidity?
2. Name as many words as you can which mean, or are caused by, moisture in the air.
3. What is meant by saturated air?
4. What is meant by 90% relative humidity?
5. What conditions of temperature and relative humidity are ideal for human beings? for plants?
6. Why is the absolute humidity greater over and near the sea than inland?
7. The relative humidity decreases, usually, as the day advances. Explain. Does the absolute humidity decrease also?
8. What is the dew point?

9. What must be the condition of the air in order that it start to rain? to snow?
10. Why is one much more quickly chilled in a wet garment than in a dry one?
11. Why is one cooled by a fan?
12. What is meant by the cycle of water in nature?
13. What conditions are necessary for condensation?
14. How are fogs formed?
15. What is the principal cause of cloud formation? Explain.
16. Why are the skies clear in a region of high pressure?
17. Why are the skies cloudy in the doldrums?
18. What is the principle of the hair hygrometer?
19. Explain how to find relative humidity by the sling psychrometer.
20. If the difference between the wet and dry bulb thermometers is very small, what does that tell about the relative humidity?
21. What portion of the atmosphere has the highest absolute humidity?
22. What part of the troposphere has the highest relative humidity? Why?
23. At what part of the day is the relative humidity highest? lowest? Why?
24. What is the difference between frost and frozen dew?
25. Why is dew or frost seldom formed on cloudy nights?
26. Why is dew usually formed on grass?

### ★*Optional Exercises*

27. Explain, using figures different from the text, how relative humidity decreases with increase of temperature, while absolute humidity may remain the same.
28. In what way does dew resemble rain? In what way is it different?
29. Frost often forms on the windows of a house that is occupied. Why does it not form when the same house is unoccupied?
30. What part of the atmosphere has practically no moisture? Why?
31. Why are London fogs particularly frequent?

## CHAPTER XXVIII

### LIGHT AND ELECTRICITY OF THE AIR

**355.** We see the sun at rising as a golden sphere, at mid-day a globe of dazzling white, and at setting, if the air is dusty, it may disappear below the horizon as a ball of fiery red.

As we ascend the mountain slope, the noonday sun takes a bluish tinge, and if we were to ascend far above the earth, we should find the sky black and the sun a brilliant white.

The ever-changing color of the sun, as it mounts in the sky or shines through clear or cloudy air, is the result of selective reflection of light.

White light is composed of many colors, each having its own wave length, and if one or more of these is taken away, the resulting light will have a different color (Fig. 278). A colored cloth often seems to have a different color during

the day and night, because during the day it reflects light received from the sun, whereas the artificial light used in the evening contains colors not present in the sun.

The shortest waves of light are the blue; and, like the small waves or ripples on water, they are easily turned aside by obstacles in their path, such as particles of dust. The longest visible rays are red; and these, like the great waves of the sea, pass by obstacles which scatter shorter waves.

An object may appear one color by reflected light (that

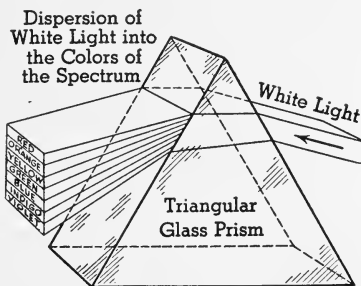

FIG. 278. White light is a mixture of many colors. These may be separated by a glass prism.

is, when we look *at* it), and a different color by transmitted light (that is, when we look *through* it). A thin gold leaf is yellow by reflected light but green by transmitted light. A glass of soapy water, viewed from above, looks bluish white, but when the sun is seen *through* the soapy water, it appears *red* or *reddish yellow*. The short blue waves are

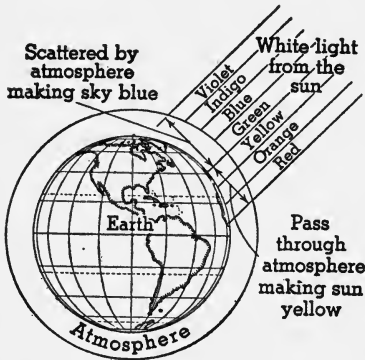

FIG. 279. Why the Sky Is Blue

scattered by the small soap particles, whereas the longer red ones pass by them.

**356. Colors of the sky.** The sky appears to us blue, and the sun yellow. This is due to the scattering of the blue rays by tiny particles of dust and moisture; only the longer waves, reds and yellows, can get through. The color of an object is due to the light it sends to our eyes. Since the

dust and cloud particles, present everywhere in the lower air, send blue waves of light to our eyes, this air, or as we call it, the sky, seems to be blue (Fig. 279). Near sunrise and sunset the light from the sun passes obliquely through much more air and therefore much more dust, which scatters more and more of the blue end of the spectrum and thus makes the sun appear less and less blue; that is, more and more red.

After a volcanic eruption the sun is always deeper red because of the quantities of volcanic dust in the air.

The beautiful colors of clouds are obtained by a combination of transmitted and reflected light effects. When the sunlight comes *through* a cloud, the reds and yellows get through. Other clouds, looked *at*, appear blue or green because the cloud scatters or reflects blue and green, while the reds and yellows are permitted to pass through.

★**357. Refraction.** When a ray of light passes obliquely from one optical medium to another of different density, it is *bent*



or *refracted* (Fig. 280). Inasmuch as the lower air is denser than the upper, every heavenly body that is not directly overhead seems to be higher in the heavens than it really is (Fig. 281). The nearer

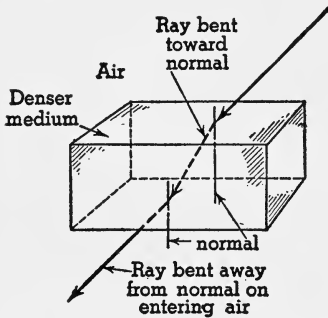

FIG. 280. Refraction of Light

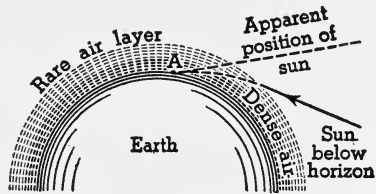

FIG. 281. Near sunrise and sunset the sun appears to be higher in the sky than it really is.

to the horizon the body is, the greater the displacement because of the greater thickness of air.

We must remember that we think we see an object in a straight line along the path of the rays of light from that object to our eyes. At sunrise and sunset the sun is seen above the horizon, when it actually is below. In that way refraction increases the length of the day. At the equator this increase amounts to a few minutes, but at the poles the long summer day is increased by about 100 hours, and the polar night is shortened by the same amount.

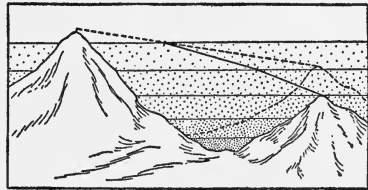

FIG. 282. An observer on the mountain at the left sees a lower mountain higher than it is because rays of light from the mountain to his eye are refracted away from the normal as they enter less dense air.

It is because of refraction, away from the normal, that an observer on a mountain top sees other, lower mountains *higher* than they really are (Fig. 282).

★358. **Looming.** The air nearest the earth is densest. If it is abnormally denser than the air ten or twenty feet higher, we get the illusion called *looming* (Fig. 283). The ray  $ZP$  bends as it strikes the denser layer of air; and by the time it reaches the observer at  $E$ , it is moving along a path  $EZ'$ . The observer at  $E$  therefore

thinks that  $Z$  is at  $Z'$ . Looming is an early morning or winter phenomenon, due to rapid radiation of the land at night and the cooling of the air near it. Ships at sea are often discovered, while yet below the horizon, by looming.

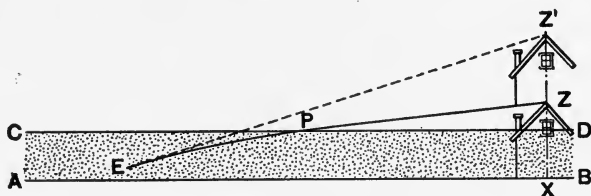

FIG. 283. Looming

★359. **Mirage** is an interesting case of refraction through air of varying density (Fig. 284). On a flat stretch of desert, it often happens that the air nearer the sand is hotter, and therefore *less dense*, than the air directly above it. Oblique rays from distant

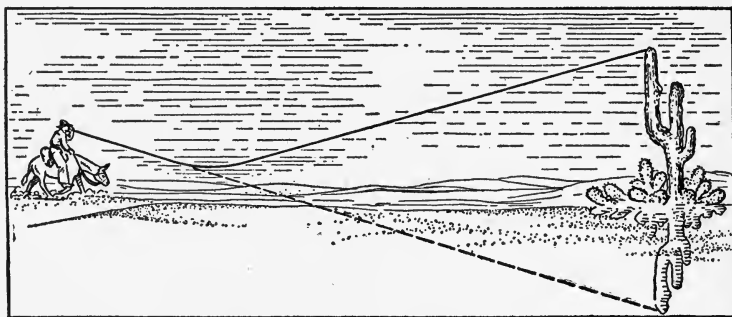

FIG. 284. Mirage on the Desert

The horseman thinks he sees a body of water in the distance.

objects are refracted by the air as it changes its density, and an illusion of a distant object inverted is obtained, as if it were a reflection from a surface of water. Caravans are deceived by mirage into the belief that they are approaching water.

★360. **Dispersion of light.** White light is a mixture of innumerable wave lengths of light of all colors. We usually distinguish seven colors, violet, indigo, blue, green, yellow, orange, and red, but there are many more than seven wave lengths. When white

light is refracted, each color is refracted differently, so that the colors separate from each other. We call this *dispersion*. The red is bent least, the violet most. (See Fig. 278.)

Dispersion of white light gives us a spectrum containing the colors mentioned above. Sometimes in front of a cyclone, cirrus clouds, that outrun and foretell the coming storm, stretch across the sky, and light or colored rings encircle the sun or moon. These are called *halos* and result from dispersion of light by ice crystals in the cirrus cloud. The red, since it is least bent, will occupy the inside of the ring and the blue the outside. As the cloud thickens with approach of the storm, the ring becomes smaller. This corroborates the very general belief that the greater the number of stars to be seen inside the ring, the greater the number of days before the arrival of the storm center.

The colored rings seen about the street light, when one views it through a frost-covered windowpane, are similar to the halos seen around the sun and moon.

The tiny water particles that constitute a fog also cause dispersion; but the nearness of these particles to the observer causes the rings to be very near the light, and these are generally called *coronas*.

**361. The rainbow** is produced by dispersion of the light of the sun by raindrops. We shall understand how this is brought about if we analyze what happens when the light passes through a single drop (Fig. 285).

A ray of white light entering a drop at any angle but normal is refracted, the blue being bent more than the other colors, the red least. Besides being refracted, some of the light is also reflected by the curve of the drop as shown. The eye, following along the line of the rays, projects their source as shown, so that we get the red on the outside and the blue on the inside. From each drop only one color will enter the eye unless the eye is moved. But other drops, in slightly different positions, will send other colors and so we get the entire rainbow. This is the *primary bow*.

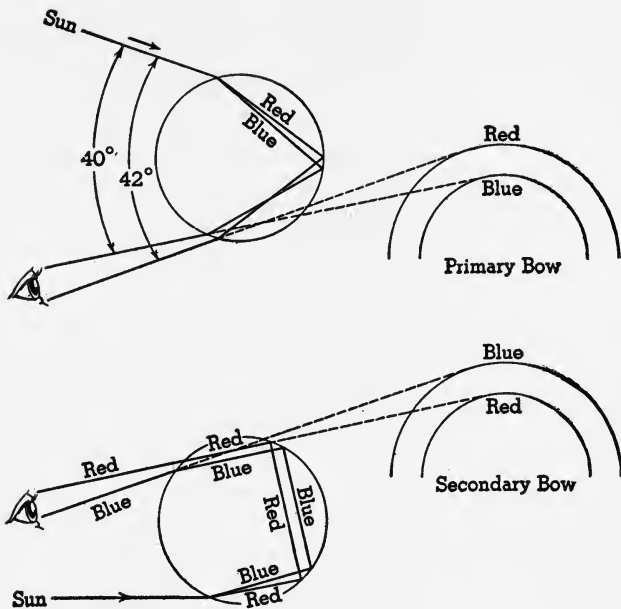

FIG. 285. The Rainbow

In order to see a rainbow, the sun must be at the observer's back and its elevation must not be too great, for if it is, the rays will pass over the observer's head, because the average angle between the sun's rays and the rays entering the eye is about  $40^\circ$ .

Similar bows are sometimes seen in the spray of waterfalls and fountains.

A less distinct *secondary bow*, outside the primary and with colors reversed, is sometimes seen. It is formed by raindrops so situated that light is twice reflected within the drop before passing out to the eye (Fig. 285). The secondary bow is less distinct because some light is always lost every time it is refracted or reflected, and the secondary is reflected twice.

A tertiary rainbow is sometimes, but seldom, seen outside the other two, with colors the same as the primary. It is

caused by light three times reflected within drops, and hence it is very faint and seldom seen.

The reason why one does not *always* see the three rainbows is that the light is not strong enough. The primary bow, being most intense, is often seen, whereas the tertiary, being least intense, is seldom seen, but it is always there just the same.

**362. Lightning.** Whenever a substance is broken up or torn apart, electrical charges are left on the two surfaces, positive on the one, negative on the other. During the up-rush of air in a thunderstorm, the raindrops are torn apart, the larger bits of drops being positively charged, the smaller, negatively. The rain that falls, consisting of the larger drops, is usually positive. The voltage, or electrical pressure, increases as the

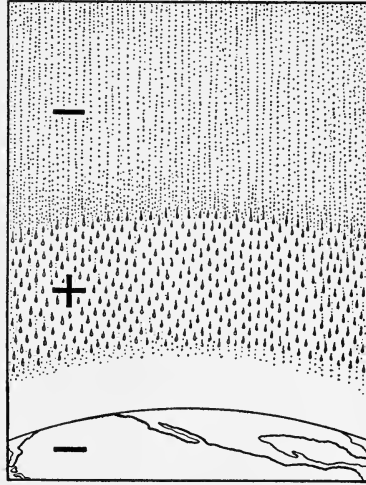

FIG. 286. The Air Just Before a Lightning Discharge

drops increase in size. The small negative drops are carried up, forming thereby three electrical layers: high up, a negatively charged mass of droplets, then a positively charged mass, and the earth itself with an induced negative charge (Fig. 286). As the voltage builds up, it finally overcomes the high resistance of the air and a spark passes, usually between the positive and negative clouds. This ionizes the air in between, making it a better conductor, and a rush of electricity follows again and again, until the electrical pressure is too low to push across the gap.

The lightning flash may be, and usually is, between the two parts of a cloud, or between a cloud and the earth, or, rarely, between two totally different clouds. Tropical

thunderstorms, which often have the most violent electrical displays, always take place in a cumulus cloud, in which we have the uprushing current of air. Hence the discharge is between one part of the cloud and another part of the cloud, and there is no danger whatsoever.



FIG. 287. A Tree Struck by Lightning

All the freak effects of lightning are due to heating. Houses are set on fire. Metal objects are melted. Trees are stripped of their bark, or entirely shattered, by the heating and expansion of water in the layer carrying the sap (Fig. 287). Objects are thrown down when their supports are melted, or broken by expansion.

★The discharge of electricity through air causes several chemical changes to take place. One important reaction is the fixation of nitrogen, causing it to combine with oxygen. The compound formed is soluble in

water and furnishes nitrogen to plants. This is one of the few sources of fixed nitrogen, which is one of the substances essential to fertility of the soil.

*The belief that lightning does not strike twice in the same place is a dangerous error.* The fact that lightning strikes in any place argues the existence there of favorable conditions, and it is more likely to happen again if a thunderstorm passes near enough.

**363. Dangers from lightning.** In the days of the ancients, lightning was regarded as a javelin hurled by the king of the gods, and it is likely that the popular idea today is somewhat similar; that some sort of long, sharp object is

being hurled from the sky toward the earth, and that if by chance a person is in its path, he will be struck. This is a superstition that ought to be destroyed. But aside from that, if the real situation were known, much of the fear of lightning that people have would be dispelled, and most of the dangers easily averted.

An atmosphere charged with electricity is like a boiler full of steam under pressure — the electrical particles repel each other because they are all alike. Now, in the case of the boiler there is no danger until a leak develops; or suppose someone on the outside of the boiler starts to bore a hole in it. As soon as the metal is weak enough, the pressure of the steam bursts the thin piece of metal and forces it out of the boiler with explosive violence. The person who has been boring the hole will be struck by the steam and badly burned. No person can be hurt except the one who bored the hole. His injury is not due to chance, but to something he did.

Similarly with the electrically charged atmosphere, the whole atmosphere from clouds to earth is charged under electrical pressure. It discharges whenever and wherever it can overcome the electrical resistance between cloud and cloud, or cloud and earth. Metals are good electrical conductors; they have very little resistance, and when a piece of metal is near the cloud and joined to the moist earth, it furnishes a path whose resistance can be easily overcome, and the cloud discharges that way. It is likely that lightning rods discharge passing clouds and prevent electrical displays by relieving the pressure quietly.

A tall tree with its roots in contact with moist earth is a conductor, but not so good as metal. Its resistance is greater; not so great, however, but that sufficient electrical pressure can overcome it, and in the process great friction develops, heat is generated, and the tree is burned. Standing under the tree one is not likely to be struck by *lightning* because the electricity is passing *through the tree*; but a branch may

be burned off and fall, or the rending of the tree by expansion may cause injury to anyone near by.

How can the discharge strike a person? That person must be a conductor with resistance less than that of the air. Suppose he holds on to a water pipe which is well grounded in moist earth, and is therefore an excellent conductor. The electricity may discharge that way, if the total resistance of person and metal is not too great; hence, the person would be *struck*; that is, the electricity would pass through him. But if the person were standing right next to the pipe and the pipe alone were struck, the person would be unaffected.

Wet objects are often better conductors than dry ones. One should, during a thunderstorm, keep dry and *not in contact with metallic objects which are grounded*, and he is perfectly safe. Wire clotheslines are a particular source of danger; posts and leaders outdoors, radiators and water pipes indoors. Do not grasp wires of radios and telephones. Open windows are not more dangerous than a closed room, since electricity penetrates every material.

As a general thing it is safer indoors during a lightning storm, especially if the building has lightning rods or grounded metal leaders.

If one must be outdoors, it is safer in a valley than on a mountain, but not under a tree. However, if there are trees, the single, isolated, high tree is the most dangerous.

**364. Protection from lightning.** The fear of lightning and the desire for protection have led to the adoption of many measures, the most common of which is the *lightning rod*.

All solids are better conductors of electricity than air; hence buildings and trees are more often struck by lightning than the open ground near them. The greater the number of trees or buildings, the greater the number of paths for the electricity and the smaller the discharge through each one. On this account, a house in the city is safer than the isolated farmhouse, and a tree in the forest is safer than a "lone tree." It is rare indeed for a modern steel building to



be struck. In fact it is highly probable that each grounded steel building acts, like a lightning rod, to carry off the electrical discharge quietly, so that it never accumulates to lightning pressure at all.

The lightning rod usually consists of a metal ribbon, or flattened tube of copper, laid over the roof of a building,

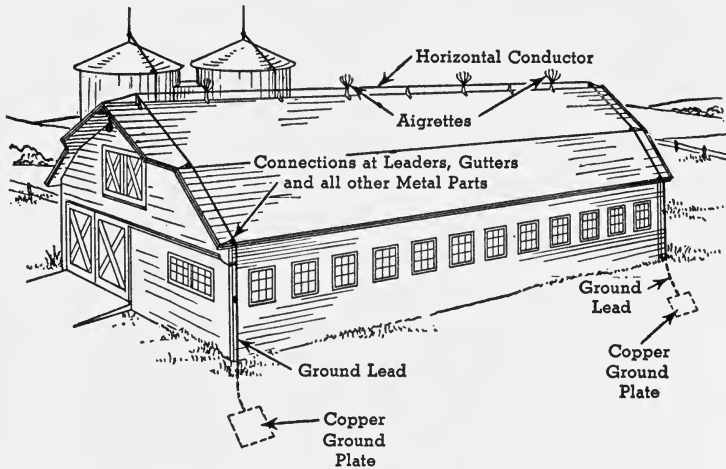

FIG. 288. Connections for Lightning Rods

with frequent pointed branches rising into the air. Electrical discharges occur on points rather than on surfaces. There must be sufficient metal to conduct the heavy current; otherwise the heating of the wire will be excessive and it may melt. It must be out of contact with combustible material like wood, which might be set afire by the heat. The lightning rod must be buried sufficiently deep in the ground to reach moist earth (Fig. 288). In the case of a petroleum tank, the safest protection is a grounded wire cage entirely surrounding the tank.

**365. Thunder.** Thunder may be likened to the noise made by an explosion. The lightning flash heats the air along its path, and the sudden push caused by the expansion starts a compressional wave or sound. Echoes cause

*rolling* thunder. Sound travels about a mile in five seconds, whereas light is instantaneous. When the lightning, therefore, is very near, the thunder clap quickly follows the flash. If the storm is a mile away, it will take five seconds, after the flash, to hear the thunder.

**366. The aurora**, sometimes called the *aurora borealis*, the *aurora polaris*, and *northern lights*, is a beautiful electrical display common in regions near the pole, but often seen in northern United States. It is believed to be due to the discharge of electricity into the upper air, at heights of 50 to 150 miles, where the air is very rare. These discharges increase with sunspot maxima, and they are now believed to be sometimes alpha particles, but more often electrons, shot from the sun toward the earth. The aurora, then, is similar to electrical discharges in rarefied gases, like the neon lamps used for signs. As seen in the United States, northern lights usually consist of a more or less distinct arch of light, extending east and west, and crossed by streamers of white or colored light, like a number of searchlights coming from a far northern point. These streamers change their length and position so rapidly that they are called "the merry dancers." They radiate from the north magnetic pole.

Brilliant auroral displays are often accompanied by severe electrical and magnetic disturbances throughout the country. Telegraph and telephone services are interrupted, radio communication is bad, and the magnetic compass becomes so variable as to be useless.

### *Completion Summary*

The sky is blue because of the scattering of blue rays of light by ———. The sun is red at sunrise and sunset because the thicker layer of air ——— blue rays, and the light that gets through the air is lacking in ——— rays.

The sun is seen above the horizon after sunset and before sunrise, because of ———.

Looming and mirage are also ——— phenomena.

★Dispersion of white light breaks it up into the —— colors because each color is —— at —— angle.

Halo is caused by —— in a —— cloud.

The rainbow is due to dispersion by —— . The secondary, with —— reversed, is fainter than the primary; and the tertiary is so faint —— .

When raindrops are —— by a —— of air, both —— are electrically charged, the smaller drops —— and the larger —— . The smaller —— carried up, form a layer above the —— . The charge finally becomes —— and a spark —— . This is lightning. Lightning causes damage because it —— , not because —— bolt or other solid missile. It does not *strike* by chance. It passes through the best —— it can find. Moist earth is a good conductor. A tall tree, with its roots —— will, therefore, —— . A tall building —— ; but if it has metallic —— in contact —— , it will carry —— to earth. If there is enough metal, so that the resistance is not too great, there will be no excessive heating, and nothing —— . This is the principle of the —— . It is likely that the large number of —— in a big city discharges passing —— quietly and prevents —— .

Thunder is the —— caused by the push of —— .

The aurora is believed to be an electrical —— from the sun into the —— .

### Exercises

1. Explain the ease with which blue rays are scattered.
2. Why is the sky blue?
3. Why is the sky red at sunset and sunrise?
4. How does a volcanic eruption affect the colors of the sky?
5. Why do some clouds look red, while, at a different time, the same clouds might be yellow?
6. What is a halo?
7. What is the cause of a rainbow?
8. Why is the secondary rainbow less distinct than the primary?

9. Why do we so seldom see a tertiary rainbow?
10. Explain how a tree is shattered by lightning, and show that the lightning does not act like a huge axe.
11. Under what conditions would a person be struck by lightning? Explain, showing that the person is not *struck*, but that the injury is due to the passing of a current of electricity.
12. State rules for safety from lightning in a storm.
13. Why is a city house much safer from lightning than one in the country?
14. Explain how to construct a lightning rod.
15. What is the cause of thunder?
16. How far away is the storm, if the thunder is heard ten seconds after the flash?
17. What is the aurora borealis or northern lights?
18. What effects has the aurora on scientific instruments?

#### ★*Optional Exercises*

19. Explain how the sun can be seen after it has dropped below the horizon. What effect has this on the length of the day? What effect has it on the length of time the sun is seen above the Arctic Circle?
20. Explain mirage with the aid of a diagram.
21. Explain the relation between refraction and dispersion of light.
22. Explain the colors of a halo.
23. Why do we not always see a rainbow when the sun shines through a shower?
24. How is lightning produced?
25. What are the chemical effects of lightning?
26. Explain why standing under a single, tall tree during a thunderstorm is more dangerous than being in a forest.

## CHAPTER XXIX

### WEATHER AND CLIMATE

**367. Weather and climate defined.** Weather is the condition of the air at a given time and place, with reference to temperature, pressure, moisture, state of the sky, and winds. These conditions, called the *elements of the weather*, are constantly changing, and as a consequence the weather is proverbially fickle.

After sunrise, as the day advances, the temperature normally rises, reaching its maximum between 1 and 3 P.M., after which it falls till near sunrise the following day. With these changes in temperature come changes in relative humidity, which drops as the temperature rises, and also changes in barometric pressure, wind direction, and wind velocity.

Climate is often defined as "average weather" over a long period; but in reality, not only the average but important extremes must be taken into account. For example, if it were 100° F. in the daytime and 30° F. at night, the average would be 65° F.; and, over a period of time, we might think of the climate as mild in that respect, whereas with extremes of 30° F. and 100° F. it is not at all mild.

We use the term *weather* in referring to atmospheric conditions at a given instant or for a short period, as a day, a week, or a month. We even speak of summer or winter weather; but when we wish to know what the climate is, we seek information about every atmospheric factor that is likely to affect our comfort and health, or our business, throughout the year, and year after year.

**368. Weather changes.** Although the fickleness of the weather is proverbial, there are important *controls*, which,

acting with different intensities and in different combinations, give us the different kinds of weather; and it is knowledge of these which enables weather forecasts to be made.

The most important weather controls are:

1. The alternation of day and night
2. The succession of winter and summer
3. The more or less systematic passage of lows and highs

The first two are fairly regular at any place, though differing widely for different places, whereas the third varies in period and intensity.

The daily and annual changes of the weather are more pronounced near sea level than at higher altitudes; in the interior of the continent than at the coast; in the polar regions than near the equator.

Convictional cyclones are more frequent over land, more vigorous in the daytime and in summer, whereas nonconvictional cyclones are more frequent and intense in winter. Both types are of longer duration over the sea, because of the greater humidity there, which makes the air less dense and starts the rising current necessary for the cyclone.

In the United States during March and April, when the land is warming up most rapidly, it is a common occurrence to have days of blustering winds succeeded by nights of calm. This is due to the rapid warming of the lower air during the day, which causes convection, whereas at night, when the lower air becomes cooler than the upper, convection ceases and the winds die down.

**369. Weather in the tropics.** Night has been called the "winter of the tropics," because the variation in weather from day to night is greater than from summer to winter.

In the doldrum belt the days are uniformly warm, owing to the nearly vertical rays of the sun. The rapid convectional ascent of the air in the morning is followed late in the afternoon by torrential downpours of rain, followed in turn by cloudless nights. The nearly equal day and night, combined with the low percentage of cloudiness, accounts

for the great daily range of temperature. Cyclonic interruptions are of secondary importance.

In the trade-wind belts, over the sea, there is a constancy of weather conditions not found elsewhere. The extreme range of temperature scarcely exceeds  $10^{\circ}$ ; and the wind blows continuously from the same direction and with about the same strength day and night. On land the range of temperatures increases, and over both land and sea there is little rainfall, except where the winds are compelled to rise over ascending land.

Though there is some variability of wind direction and some precipitation in the trade-wind belts, owing to the cyclones which develop there, the constancy of the wind and the deficiency in rainfall are the marked characteristics of this belt. However, continents and islands and, to a more marked extent, mountain ranges that lie across the path of the trade winds are usually well supplied with rain. As illustrations of this, note the abundant rainfall of eastern Australia, eastern Africa, and eastern Brazil; the northern slopes of the West Indies and the Hawaiian Islands; and the eastern slopes of the Andes and the mountains of Mexico. In all these cases, the winds blow over the water just before they are *forced to rise* over the land, which in all these cases is high. As the air rises, it expands and cools until it reaches the dew point, and then precipitation takes place.

Regions on the borders of the trades have monsoon changes of weather. If these regions are near the doldrums, there is the alternation of the light winds and abundant rains of the doldrums and the constant winds and light rains of the trades. If they lie near the high-pressure calms of the horse latitudes, then the characteristic conditions of the trades alternate with those of the horse latitudes.

**370. Weather outside the tropics.** In the zone of *prevailing westerlies* weather changes are irregular and mainly of cyclonic control, with marked differences in the two hemispheres. In the southern hemisphere, where there is

little land to interrupt them, the westerlies attain a constancy approaching that of the trades, and so high a velocity that they are called the "roaring forties." In winter the cyclones are more frequent and succeed each other with almost periodic regularity.

In the northern hemisphere, where the land is massed, there is a strong contrast between the weather of the land and the water areas of the prevailing westerlies; the land areas have much greater extremes of weather conditions, both daily and seasonal. The greatest seasonal ranges of temperature are found in the interiors of the northern continents. In northern Siberia there is a range of about 200 °F. In central United States a range of 130° F. is not uncommon.

★As a result of the massing of the continents in the northern hemisphere, the North Atlantic and North Pacific oceans are *low-pressure centers* during the northern winter, and *high-pressure centers* during the northern summer. Over northern America and Eurasia the pressure is low in summer and high in winter. It is from these seasonally permanent pressure centers that the cyclones of lower latitudes are projected.

In the *frigid* regions, although temperature changes are determined chiefly by the appearance and disappearance of the sun, the other weather elements are controlled mainly by the passage of cyclones. The precipitation, though less abundant, is mostly in the form of snow which accumulates upon the land. If more snow falls than disappears by melting and evaporation, its accumulation results in the formation of an ice sheet, like that which covers Greenland and the Antarctic continent.

**371. Weather prediction.** After a thorough understanding of the relative values of the factors determining weather in any region, it is possible to predict, with a high degree of accuracy, the changes of weather likely to occur. The degree of accuracy attainable varies with the season and with geographic position. Under the doldrums and trade winds, where the daily change is dominant, weather prediction



may be made with an assurance almost amounting to a certainty that it will be fulfilled. Indeed, the weather changes there are so regular and certain that the weather is not a topic of conversation.

In regions where the weather is due mainly to cyclones, it is not possible to predict with nearly so high a degree of accuracy. Yet even here the relative values of the factors are so well known and the systematic movement of cyclonic disturbances so well understood that predictions may be made with the reasonable expectation that a large percentage of them will be fulfilled. These predictions for any station must take account of: (1) the systematic movement of cyclonic disturbances, their strength of development and place of origin, and direction and rate of movement; (2) the season; and (3) local topography.

**372. Weather in the cyclone.** To understand the weather conditions which prevail about lows and highs, it is necessary to remember the directions of the winds about these disturbances and the effect upon the humidity resulting from a change of temperature.

In the United States, cyclones, as we have seen, move eastward, and the winds blow in toward the cyclonic center in counterclockwise spirals. At any station the wind will not, as a rule, be blowing *directly toward* the center, but a little to the *right of it* (Fig. 289). Therefore, in front of the cyclone, the winds are blowing from a *warmer* to a *cooler* region (south to north) and their relative humidity is increased. As they approach the center of the low, the air rises, and its humidity is further increased by *cooling from expansion*. This may be sufficient to bring the air to saturation. As a result of these conditions, *a rising temperature with cloudiness or precipitation* generally characterizes the front of the low and may be predicted as a well-developed cyclone approaches.

In the rear of the cyclone the winds are moving from colder to warmer regions, north to south; and as a result,

the relative humidity of the winds is lowered and the skies are therefore clear.

As a result of this difference in conditions behind and in front of the cyclone, the increase in humidity, due to ascent, may bring the air in front of the cyclone's center to the saturation point, and yet not saturate the less humid air in its rear. Consequently, *falling temperatures and clearing skies*

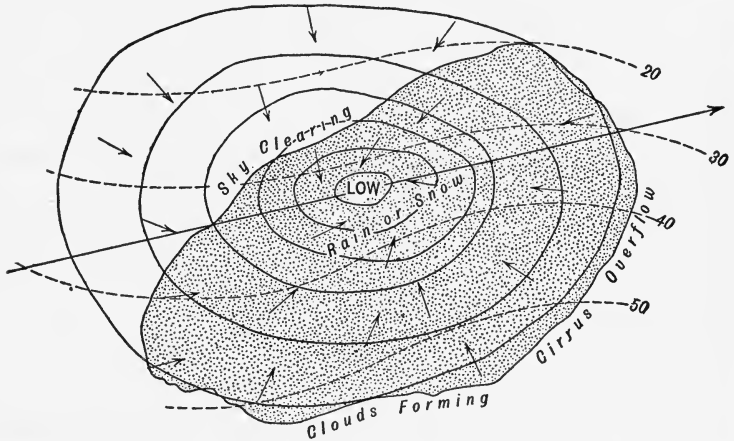

FIG. 289. An Ideal Low

The heavy arrow indicates the movement of the low toward the northeast.

Note cloudiness with rain or snow in front of low. In the rear of the low note clearing skies.

may be expected after the center of a well-developed cyclone passes.

The direction of the shifting of the wind depends, as we have seen, upon the position of the path of the cyclone's center, whether north or south of the station. (See p. 399.) Ordinarily the *strength* of the wind *increases* as the cyclone *approaches*, and *decreases* as the cyclone *recedes*.

In winter the strong indraft of cold air in the rear of a cyclone, if accompanied by snow, is known in the United States as a *blizzard*.

**373. Weather in the anticyclone.** Since the movements of the air about a high are the reverse of its movements about

a low, it follows that the conditions in respect to temperature and humidity which prevail about a high are likewise the reverse of those which prevail about a low. In front of a high the winds are northerly, and behind a high the winds are from a southerly quarter, while at the center of the high the air is sinking. Consequently, fair and cooler weather is usually predicted as the high approaches, and rising tempera-

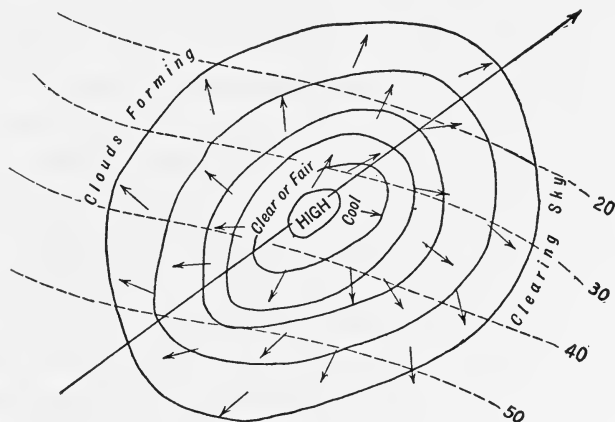

FIG. 290. An Ideal High

The heavy arrow indicates the movement of the high toward the northeast. Clear, cold weather characterizes the front of the high and warmer, cloudy weather appears at the rear.

tures with possible cloudiness or even precipitation as the high recedes.

Since the winds *start* from the center of the high, unlike the low, the winds *weaken* as the high approaches and *strengthen* as it recedes. For example, a person directly in the middle of a high would feel very little wind, since air is moving *away* from him. As with the low, the direction of the shifting of the wind is determined by the position of the station with reference to the path of the center of the high.

In winter, if a high follows closely in the wake of a well-developed low, the fall in temperature may be abnormal. If it is as much as 20° F. in 24 hours, reaching a temperature of

freezing or lower, it is called a *cold wave*. In southern United States the term is applied to changes somewhat less than 20° F., even if it does not drop below freezing.

**374. Weather service.** The United States Government has established a weather service extending to all settled parts of the country. This service, which is the work of the *Weather Bureau*, a division of the Department of Agriculture, has its central office in Washington, D.C. Its corps of observers to the number of more than three thousand, paid and voluntary, are distributed throughout the country. Regular observations of the weather are made at more than two hundred stations, as nearly as possible at the same instant, 8 A.M. and 8 P.M., 75th meridian time, and are reported by telegraph to the central office at Washington and to each other. The most important observations are: *pressure; temperatures, current, maximum, and minimum; direction and strength of wind; amount and kind of precipitation during the past 24 hours; and percentage of cloudiness.*

**375. Weather maps.** When these data are collected and plotted on a map of the United States, the result is a *weather map*. (See Fig. 262.) The daily map is published at the central office in Washington, and also at one or more substations in every state. It not only sets forth the weather conditions existing at the time of observation, but also serves as a basis for prediction of the weather for the 24 or 36 hours following.

Each local map supplements the general prediction for the entire country with a forecast for the particular locality. To be of value for purposes of forecasting, weather maps must be distributed the day issued, since weather conditions are constantly changing.

Since our weather is mainly of cyclonic control and since the cyclonic disturbances move eastward across the country, the weather map as a basis of weather prediction is of more value to the eastern than to the western part of the country. On the Pacific coast it is of little value, since there are few stations farther west to report coming changes. With further

extension of wireless telegraphic service and the radio, the value of the weather service to the western coast will be correspondingly enhanced, because information will be obtained from vessels on the Pacific.

**376. Value of weather predictions.** Every observer is familiar with the daily and seasonal changes of temperature, also with the fact that there are other important changes that are irregular in their occurrence. More and more people are learning to appreciate the relation of these unperiodic changes of the weather to the eastward march of cyclonic disturbances, and to appreciate the great value of our weather predictions. Each year brings a wider use of these predictions and the more general rejection of the predictions of charlatans who make year-long forecasts.

Among the first to realize the benefits of our weather forecasts were the shipping interests of our southern and eastern coasts and of the Great Lakes. Not infrequently censuses have shown that marine property to the amount of more than \$25,000,000 has been held in port because of storm warnings issued. Few masters of vessels now leave port without knowing the latest forecast of the weather.

Shippers of perishable goods are also interested in weather predictions. Estimates from shippers place the value of property saved by the warning of the *cold wave* of January 1, 1898, at nearly \$5,000,000. Aviators, skippers, farmers, planters, truck growers, and fruit growers are interested in being forewarned of the changes in the weather, especially when these changes mean destructive winds, floods, or frosts.

It is our confident belief that, with a more extended field of observation and a better knowledge of upper air conditions, the present practical limit for safe predictions (36 hours) may be considerably increased.

**★377. Weather signs and proverbs.** There are two distinct classes of weather signs. The first is based on century-long observations by those whose occupations have led them to observe weather

changes closely; the second class includes a mass of superstitions that have been strangely preserved and transmitted. The signs of the first class have usually found expression in trite sayings that have come to be known as *weather proverbs*. As an aid to memory these proverbs are commonly expressed in rhyme.

“Rainbow in the morning, sailors’ warning; rainbow at night, sailors’ delight” is a proverb that is true only in those regions where cyclonic storms move eastward. If the rainbow is seen in the morning, the storm center is apt to be westward, and its further progress will bring it nearer.

“Mackerel scales and mares’ tails make lofty ships carry low sails” is applicable the world over. The long, wispy clouds called “mares’ tails,” and the sky flecked with cirro-cumulus clouds known as a “mackerel sky,” are the result of the high-level overflow of air in front of a cyclone. Consequently they presage a *coming* storm. “Mist rising o’er the hill brings more water to the mill” the world over.

Weather proverbs are usually of only local application, though many are worldwide. When local, in order to appreciate them one must be acquainted with the local conditions.

**378. Climatic controls.** Since climate is but average weather, those conditions which control weather likewise control climate. The most obvious, and perhaps the most important, climatic controls are:

1. Latitude
2. Height above sea level
3. Distance from the sea
4. Position with reference to mountain ranges
5. Position with reference to prevailing cyclonic paths

Although climate is defined as the *average* condition of the air with reference to the various climatic elements, *it does not follow that when these averages are the same, the climates are alike or even similar.*

New York City and San Francisco have about the same *average* temperature for the year, but New York has *hot summers* and *cold winters*, whereas San Francisco has *equable* temperatures throughout the year. The central Mississippi

Valley has about the same *annual rainfall* as the coast of California; yet in the interior the rains are *distributed through the year*, whereas on the western coast they are *confined to the winter months*.

Of vastly greater importance than *averages* are the *extremes* of climatic conditions, and the distribution of these conditions through the year.

**379. Climatic zones.** Temperature being the most important climatic element, and depending, as it does, mainly upon latitude, the earth may be divided into east-west zones, each of which furnishes a distinct type of climate. Within any zone there may be considerable variation from the type, yet there is sufficient similarity to justify the division into zones (Fig. 291).

The customary division, whereby the zones are bounded by parallels, gives us zones of light rather than climatic zones; therefore the tropics and polar circles are not boundaries for torrid, temperate, and frigid climates. A more reasonable boundary is the *isotherm*. It has been suggested that the *average annual isotherm* of 68° F. be taken as the poleward boundary of the torrid zone, and the *summer isotherm* of 50° F. as the poleward boundary of the temperate zones.

The temperature of 68° F. is about the temperature we desire for our houses in winter, and the temperature necessary for so-called tropical plants; a temperature of 50° F. is necessary for trees and for the maturing of the hardier cereals.

The temperate zone is the widest zone, and wider in the northern than in the southern hemisphere. This is due to the excess of land north of the equator, as land is a better absorber of insolation than the sea. The frigid zones or, more accurately, the *polar cold caps* have an average temperature, even in the hottest month, below 50° F.

In classifying climates, the separation into temperature zones does not take into account the very important element

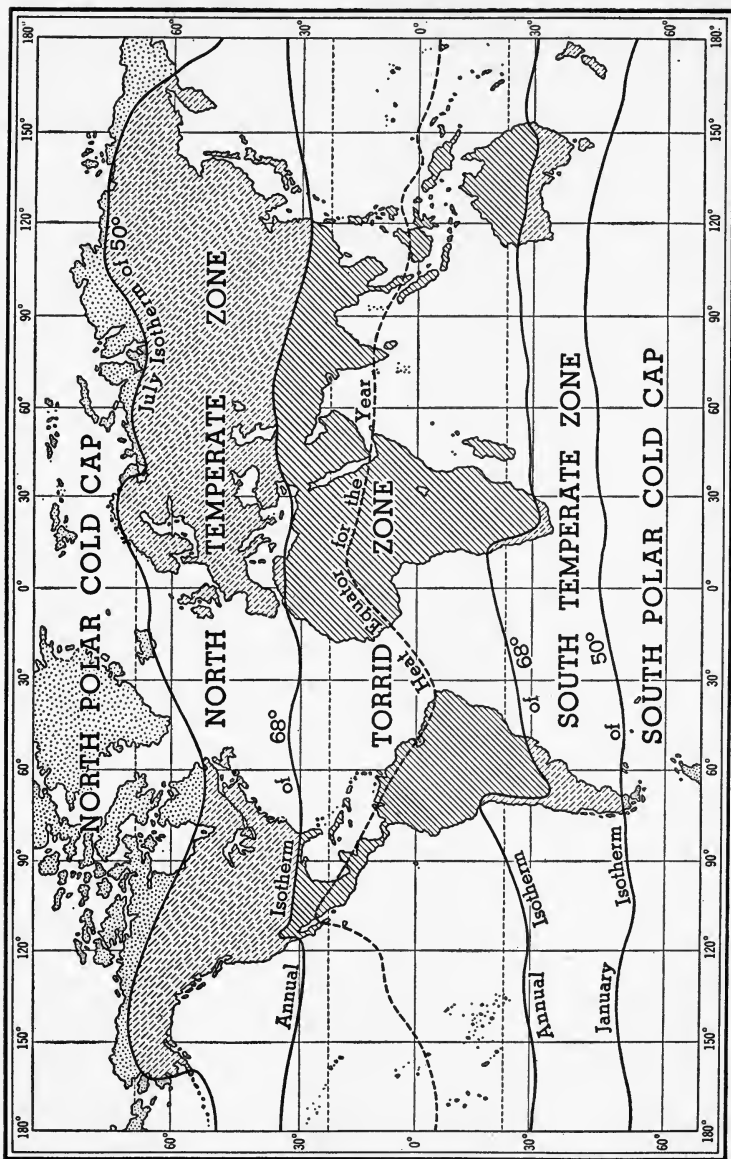

Fig. 291. The Climatic Zones. There is much more land in the north temperate than in the other zones.



of rain, and we shall therefore have to subdivide each zone into climatic types.

**380. Tropical rainy climates.** The temperature of all climates of the torrid zone is high, 75° F. to 100° F., except where mountains rise into cold altitudes.

The almost vertical rays of the sun heat up the lower air in the early forenoon and cause rapid convectional currents. These rise by noon to such altitudes that their cooling by expansion produces condensation of their vapor, the formation of clouds, and rain in the early afternoon. The rains are of almost daily occurrence throughout the year.

The other climate elements call for a subdivision into these types:

1. Constantly wet forest
2. Savannas with wet and dry seasons
3. Monsoon savannas, with a short dry season

1. *Tropical rain forest climate.* Besides the high temperature, which continues into the night and from day to day, the air is charged with moisture which comes down every afternoon in a heavy cyclonic storm. The total annual rainfall in this climate is 100 inches or more, and dense forests are common.

Man finds this climate oppressive and enervating because of the combination of temperature and humidity. Tropical rain forest regions include the Amazon Valley in South America; and, in Africa, the valley of the Congo River and part of the west coast. Southern Asia and the East Indies are tropical rain forest.

2. *Tropical savanna climate* has a definitely separated wet and dry season, giving fewer and less dense forests and more extensive regions of tall grass like the prairies. Temperatures are high, although part of the dry season is slightly cooler. Rainfall is extreme: very much during the wet season, and very little during the dry season. The total rainfall may reach 50 inches. The rainy season occurs during periods of high altitude of the sun. The savannas of the northern hemisphere are having a rainy season while those of the southern are undergoing a dry season.

Savannas are situated farther from the equator than the rain forest areas, between the doldrums and the trades; and it is the

shifting of these belts which causes the dry and wet seasons; the trade wind causes a dry and the doldrums a wet season. Representative regions are the Llanos of the valley of the Orinoco River in Colombia and Venezuela, the Campos of Brazil, the Sudan in Africa, and the grasslands of northern Australia.

3. *Monsoon savanna climate.* Wherever the monsoon winds blow, a modified savanna climate prevails. During the dry period the land breezes are very strong because they strengthen the trade winds. In India the season starts in October. The climate is clear and cool. By February it gets warm and dry, but this season is short and is soon followed by the rainy season, when the sea breezes blow from the ocean. Because the winds are forced to ascend high mountains, the rainfall here is the heaviest in the world, *500 inches per year* at the foot of the Himalayas. Monsoon savannas differ from the tropical savannas in that the rains are not the doldrum variety, but are of sea-breeze origin.

**381. The dry climates.** A climate is considered dry when evaporation is greater than rainfall; there is no permanent ground water nor are there permanent streams, except such as merely flow through the region, their source being in some more humid area.

There is often a region of semiaridity separating the dry from the humid regions. These semiarid areas are called *steppes*. But there is no sharp line of separation between them. In the United States a region is considered dry if the annual rainfall is less than 10 inches, and semiarid if it is between 10 and 20 inches; but such a criterion does not hold throughout the world; for while a 25-inch rainfall in Nebraska might leave the region humid, the same rainfall in equatorial Africa still leaves the region parched, because of the rapid evaporation due to heat. We have to consider then, *two types of dry climate: the equatorial and temperate.*

The temperatures of the dry climates are extreme, high in the daytime and low at night. The relative humidity is very low, from 10% to 30% during the day, permitting the

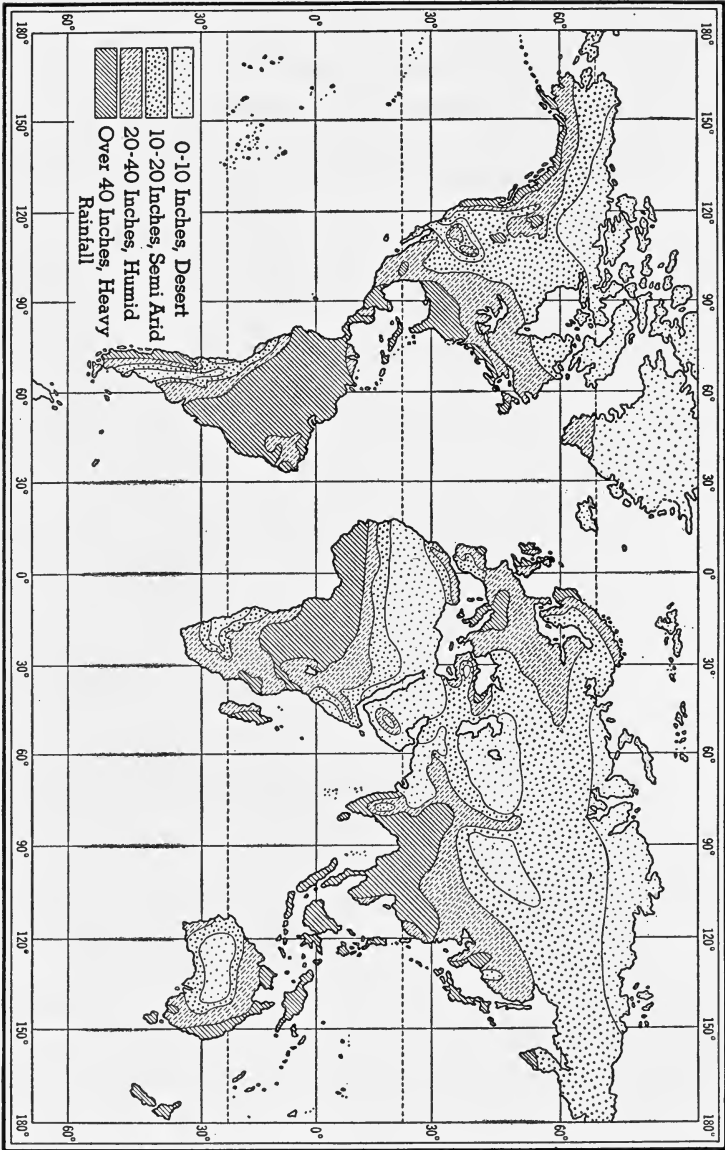

Fig. 292. Rainfall Map

sun's heat to penetrate the clear, cloudless atmosphere. Conversely, at night radiation is rapid and the land cools. It is not uncommon in Arizona to have a temperature of 130° F. during the day, followed by freezing temperature at night.

The air is often filled with fine dust, since it is in such regions that wind action is at a maximum.

**382. Equatorial deserts.** The trade winds that pass over land areas are drying winds; and they are the chief source of equatorial deserts. Such a belt is found in Australia, Africa, South America, and in our own southwest, where the rainfall is under two inches a year. In northern Chile the average rainfall for a 20-year period was less than one tenth of one inch per year. On the Sahara Desert, the rainfall is less than five inches. But not only is the rainfall on deserts very small but it is very uncertain. In the Chilean desert it may not rain for five years at a stretch. In some of the desert areas rain may come in sudden downpours, which, because of the sparse vegetable cover, becomes a torrent, destructive in its velocity. Much of the water evaporates rapidly, the rest sinks into the ground and forms springs and playa lakes which, however, soon dry up.

The skies are clear although occasionally a cloud develops and even a thunderstorm; but the rain may evaporate without reaching the ground.

Relative humidity as low as 2% with temperatures over 100° F. are known on the Sahara. Temperatures in summer run up to 110° F., and the highest ever recorded was 136° F.

**383. Deserts of the temperate zone** are not situated there because of their latitude, but rather because they are far inland on the continents, or separated from the ocean by highlands. Hence the great deserts of the temperate zone are in the central areas of Asia and North America, the two largest continents.

The chief difference between these deserts and those of the torrid zone is the temperature. In the temperate zone, deserts have a severe cold season.

384. **Steppes or semiarid climates.** On the margins of the deserts in both the torrid and temperate zones, there are semiarid areas in which the rainfall is about twice as great as in the desert. But farming is almost impossible, because

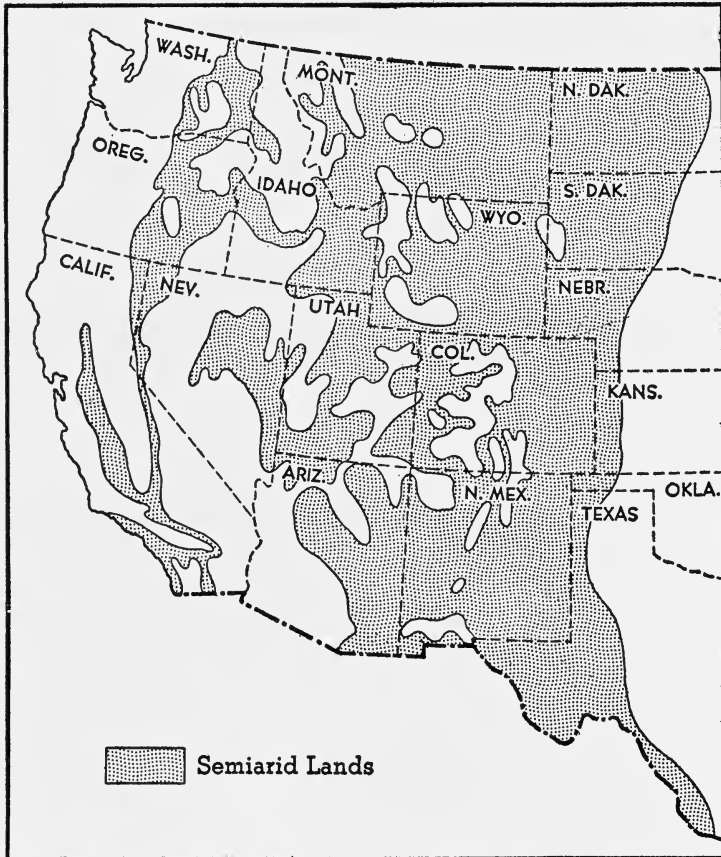

FIG. 293. The Steppes of Western United States

the rainfall is not dependable unless supplemented by irrigation. Such regions are more often given over to grazing, because grass will grow when it rains and turn to hay when it becomes dry and warm. A large section of western United States is steppe land (Fig. 293). It is there that great irriga-

tion projects, such as those at Roosevelt and Boulder Dams, are reclaiming vast areas of our country.

**385. Moist temperate climates.** In the equatorial climates the important factor is the rain; hence climates there are classified as rainy or dry. But in the temperate zone the temperature becomes more important, and the seasons, instead of wet and dry, are summer and winter. In the torrid zone there is always enough heat, and the important need, then, for plant growth is water. In the temperate zone the most important factor in growth of plants is the amount of sunshine, and farming is done chiefly in summer.

The succession of cyclones and anticyclones which causes important changes in the weather is an important feature of these regions.

**★386. Mediterranean climate** has dry summers and moist, mild winters. Skies are clear and, in general, the climate is considered almost ideal for a winter resort. The Mediterranean lands, southern California, South Africa, and South Australia have Mediterranean climate.

It will be noticed that these areas are all located near the edges of the tropical climates or on the western coasts. They are in the paths of the prevailing westerlies, which are moist, and on the shifting of the wind belts they lie in the tropics; this gives them dry summers with clear weather and mild winters with cyclonic changes, but these are not so common as farther north. But even in winter the weather is good; rains are few but heavy, and the sky is not often overcast.

Nearness to large bodies of water makes for mild temperature changes: 40° F. to 50° F. in the winter and 70° F. to 80° F. in the summer. But humidity is low in the summer, and the heat, even when it is 95° F. as in some places in California, is not oppressive; and then, these hot days are followed by cool nights, around 60° F., and day after day this same good weather is repeated.

**★387. Moist subtropical climates** have more rain than the Mediterranean climate, and the rain is spread over the entire year or is concentrated in the summer, rather than in the winter. South-eastern United States (Gulf States), part of the Argentine, eastern

China, and Japan are representative regions. In general these lands lie on the eastern sides of continents, where they are bathed by warm ocean currents.

Temperatures are like those of Mediterranean regions. Summer temperatures are high and the air is moist, 70% to 80% relative humidity. The nights as well as the days are hot and uncomfortable because radiation is prevented by clouds.

In winter the temperature is mild, about 60° F. in the daytime and 40° F. at night. The growing season is long and well suited to oranges, pineapples, and other crops requiring a long time to mature. But frost is not unknown; in southern United States it is quite common, and it results in great loss to the fruit growers.

**388. Marine west coast climate.** The western coasts have the benefit of the *tempered westerlies* coming from the ocean. This gives throughout the year an evenness of temperature not found on the eastern coasts of the temperate zone. There is more rain, sometimes up to 100 inches, and it is concentrated in the winter months, because in winter the colder land chills the moist winds from the ocean; and that brings winter fogs as well.

The northern and southern hemispheres differ widely in the climates of their western coasts, as a result of ocean currents. Alaska and northwestern Europe are warmed many degrees above normal by winds from the great warm currents in the Pacific and Atlantic oceans, while Chile, western Africa, and Western Australia are cooled as a result of the branches, along these coasts, of the cold Antarctic current.

The climatic influence of warm and cold currents is much greater on windward than on leeward coasts. In the westerlies the windward coasts are the western coasts, whereas in the trade belts the windward coasts are the eastern coasts.

**389. Continental and marine climates.** Continental humid climates are found in central and eastern United States and Europe and in eastern Asia. The interiors of all continents are marked by great variability of temperature, which decreases as we approach the coast.

Winters and summers are severe. In the summer the temperature may exceed 100° F., while winters may drop to 30° below zero. Chicago, in this area, experiences these extremes. Rainfall is small inland and there are frequent periods of drought, but the low temperature makes drought less disastrous.

Temperatures at the seacoast are not subject to these extremes for the following reasons:

1. Water rises in temperature much less than land for the same insolation.
2. Water radiates much less than land.
3. Ocean currents distribute the heat more uniformly.
4. There is more cloudiness over the ocean.

★390. **Mountain climates.** As we ascend a mountain in any latitude, all the climatic elements change from those prevailing at the base of the mountain. It gets colder, absolute humidity decreases, and relative humidity increases until the dew point is reached, and then decreases. Precipitation increases for a time as we ascend, and then gradually fails; and winds increase in strength and constancy.

On the whole, all of the climatic elements become more constant with altitude; and this sameness is the most marked characteristic of mountain climates.

The windward and leeward sides of mountains, and particularly of mountain ranges, are likely to present very different types of climate. The windward side, owing to ascending currents, which expand and cool, has an excess of rainfall, while the leeward side with descending currents, which get warmer, is likely to be dry. In the trades the eastern slopes receive the rainfall, whereas in the westerlies the eastern slopes are dry.

The arid regions of Nevada and western Argentina are examples of arid regions to leeward of mountains in the westerlies; and the arid western coasts of Mexico and Peru lie to leeward of mountains in the trade-wind belts.

The southern slopes of the Himalayas receive most of their rainfall while the southwest monsoon blows; and the northern



slopes of the Atlas Mountains of northern Africa are the windward and therefore the rainy slopes.

★391. **Polar climates** are characterized by freezing temperatures most of the year, day and night. But nearer the polar circles, in summer, when there are 24 hours of daylight, it may reach 75° F., and plants grow for a short period.

Precipitation is less than 10 inches over most of the area; but this does not make for desert conditions everywhere, since the precipitation is snow and little evaporation takes place. In fact, much of the area is covered by an ice cap.

The polar cold cap is much more extensive in the southern than in the northern hemisphere, possibly because of the aphelian winter.

An important factor in the polar climates is the long polar day and night. For about 6 months it is day; and for the following 6 months it is night.

★392. **Climates of the past.** It is now known that there have been great changes of climate during past geological ages. Evidences of these changes are found in the character of the rocks and in the fossils found in them. Glacial climates have existed in the United States as far south as New York (page 120), Cincinnati, and St. Louis, as well as in northern Europe, South America, Africa, and Australia. Evidences of warm climates have been found in Alaska, Greenland, and Spitzbergen.

393. **Glacial climates.** Evidences of former glacial climates are recognized chiefly in the character of the deposits left by the ice sheet. These deposits, known as glacial drift, are unsorted, angular, faceted (rubbed flat), and striated (scratched and grooved). The deposit of the last glacial period is a confused mixture of clay, sand, gravel, and boulders. Since it was so recently formed, it is the surface deposit of much of northern United States and Europe. It is loose and unconsolidated.

Similar deposits have been found, in various countries, in rocks laid down during past geological periods and now covered by great thicknesses of other rock. These deposits, now consolidated, are known as *tillite*; and, wherever found, they are recognized as unquestioned evidence of glacial climates of the past. Such deposits are made only by glacial action.

★394. **Warm climates.** All theories concerning the evolution of

the earth agree in the belief that the sea was originally hot, even boiling.

Reef-making corals thrive only in waters that are warm — seldom below 68° F. In the present seas they are found mostly in the tropics, no farther north than the Bermuda Islands. This is due to the great, warm Gulf Stream, that flows past these islands.

It is not surprising then to find that vast masses of rock of the early periods of the Paleozoic Era are made of coral. We find such rock in New York, Tennessee, Alaska, and Spitzbergen, indicating that in the distant past these regions were bathed by warm waters.

It is worthy of note, too, that the cold periods of the earth's history coincided rather well with mountain formation, while there were warm periods, more often, during times of widespread submergence.

For example, toward the end of the Permian period, when the Appalachian Mountains were uplifted, continental glaciers were common in many parts of the earth. On the other hand, the Pennsylvanian was a time of low, swampy land; and it was at that time that there were great tropical forests covering the land.

The evidence of this is that the fossil trees of the Pennsylvanian coal do not show rings of growth as do the trees of temperate climates. In our modern tropical forests we also have trees which do not show these rings, because their growth is not suspended by a season of cold. Hence we can assume that the climate of the Pennsylvanian was of the tropical rain forest type.

Some of these fossil trees have been found north of the Arctic Circle.

**★395. Aridity of past ages.** In arid regions evaporation exceeds rainfall, and lakes in such regions are salt. At the same time, beds of salt and gypsum are deposited on the borders, as at our Great Salt Lake and the Caspian and Dead seas. No such deposits form in humid regions.

In the distant past these regions were humid. We find evidence of the existence of a much larger fresh-water lake, ancient Lake Bonneville, which has now shrunk to the Great Salt Lake, because of a change in climate from humid to arid.

Similar changes must have occurred in all regions where we find deposits of salt and gypsum in the rocks of past ages. Such

deposits are found underlying much of the area of New York, Ohio, Michigan, Kansas, Oklahoma, and Louisiana; and it is worthy of note that the greatest salt deposits of the world, particularly at Stassfurt, Germany, are of the Permian period. During the Permian, the land was rising rapidly and this may have been responsible for the world-wide aridity. These regions are today humid, indicating another change in climate since ancient geological times.

### *Completion Summary*

Weather depends upon \_\_\_\_\_ air.

Climate is \_\_\_\_\_ weather, together with \_\_\_\_\_ extremes.

In the tropics, weather is \_\_\_\_\_. Every day there are \_\_\_\_\_, while nights \_\_\_\_\_.

In the trade-wind belt, weather is \_\_\_\_\_. Rainfall is \_\_\_\_\_ except \_\_\_\_\_.

In the regions of prevailing westerlies, \_\_\_\_\_ cyclones.

Weather prediction is \_\_\_\_\_ necessary in most regions except where \_\_\_\_\_ cyclonic storms.

As a cyclone approaches, the weather will be \_\_\_\_\_ with probable \_\_\_\_\_, and as it passes, \_\_\_\_\_ and \_\_\_\_\_.

The United States Weather Bureau prepares \_\_\_\_\_ day, a weather map and \_\_\_\_\_ prediction for \_\_\_\_\_. These are of much \_\_\_\_\_ value for \_\_\_\_\_ eastern \_\_\_\_\_ country.

Climatic zones based on \_\_\_\_\_ may be established by using isotherms instead of parallels. In such zones will be found several climates, controlled chiefly by \_\_\_\_\_.

In the tropics we find several kinds of rainy \_\_\_\_\_, and several kinds of \_\_\_\_\_ climate.

★The tropical rainy climates include \_\_\_\_\_; \_\_\_\_\_ wet and dry \_\_\_\_\_ and \_\_\_\_\_ savannas.

The dry climates include \_\_\_\_\_ and \_\_\_\_\_.

In the temperate zone we also have \_\_\_\_\_ and \_\_\_\_\_, whose situation has no relation to their \_\_\_\_\_, but rather because they are \_\_\_\_\_ continent, or \_\_\_\_\_ sea by \_\_\_\_\_.

★Mediterranean climate is ideal. It is usually found on —— coasts, whereas on the eastern coasts we often find —— climate, not very comfortable, but good for ——.

In marine west-coast climates we find —— temperature and —— rain. These climates are modified by —— which, in the —— hemisphere, are different ——.

Continental humid climates are usually found in the temperate zone, in the —— and eastern —— . In the central sections temperatures —— . Near the coast temperatures —— and rainfall —— .

★On mountains climatic conditions are —— . On the windward side —— .

The important factors in polar regions are —— and the —— day.

In past geological periods climates —— . Glacial conditions are shown by —— . Warm climates are indicated by —— , which we find even in —— . Tropical rain forest —— must have prevailed in the —— when —— coal —— . In the Permian it must have been —— , which gave us the extensive salt —— .

### *Exercises*

1. Climate is average weather. Why is that statement not quite true?
2. Distinguish between weather and climate.
3. What are the important weather controls? Which are regular?
4. Why are spring days windy, while the nights are often calm?
5. What is meant by "night is the winter of the tropics"?
6. Describe the weather of the doldrum belt.
7. Why are weather predictions in the trade-wind belt unnecessary?
8. Why are weather changes more pronounced near sea level than at higher altitudes?
9. Why are weather changes more pronounced inland than near the coast?

10. Why is weather more variable in polar than in equatorial regions?

11. Where do we find monsoon changes of weather?

12. What is the chief weather control in the regions of prevailing westerlies?

13. Where do we find the greatest temperature range in the United States? How do you account for it?

14. What is the chief weather control in the polar regions?

15. Why is weather a common topic of conversation in the temperate zone?

16. What is the direction of the wind in front of a cyclone in the westerlies?

17. Why is the front of a cyclone apt to have cloudy or rainy weather?

18. Why does relative humidity decrease in the rear of a cyclonic storm?

19. How does the velocity of the wind change as a cyclone approaches?

20. What weather prediction should be made as a high approaches?

21. What weather prediction should be made as a high recedes?

22. Why does the wind weaken as a high approaches?

23. How does a *cold wave* develop?

24. Why is the weather map of more value to eastern than to western United States?

25. How far ahead can the weather be predicted?

26. Of what commercial value is the weather forecast?

27. Name the climatic controls.

28. Cite an example to show that two places with the same average for one of the climatic factors may not have the same weather.

29. Upon which one of the climatic factors does the usual division into zones depend?

30. Along what isotherms would it be advisable to separate the temperature zones?

31. What are the chief conditions prevalent in the tropical rainy climates?

32. What is a dry climate? Why cannot the amount of rainfall be used as an index of a dry climate?

33. What are steppes?
34. Why are the temperatures in a dry climate extreme?
35. What is the chief cause of equatorial deserts?
36. What is the smallest rainfall in the world? Where?
37. Why are the skies clear in deserts?
38. What is the cause of deserts in temperate zones?
39. How do temperate-zone deserts differ in temperature from tropical deserts?
40. Where are the steppes of the United States? What can they be used for?
41. Which climatic factor is of paramount importance in the temperate zone? How does that affect agriculture?
42. What other important factor is the chief determinant of weather in the temperate zone?
43. Account for the even climate of western Washington and Oregon.
44. Why are the rains of the west coast concentrated in the winter?
45. Explain the difference in marine west-coast climates of the British Isles and Chile.
46. What is the climate of New York State?

#### *★Optional Exercises*

47. Why are northern North America and Eurasia low-pressure centers during the summer, and high-pressure centers during the winter?
48. Explain why we get falling temperatures and clearing skies after a cyclone passes.
49. Why is the weather prediction not always correct?
50. Discuss weather proverbs, and show that they usually have only local application.
51. Why is the subdivision of the earth into temperature zones inadequate for climates?
52. Name a characteristic tropical rain forest region. What is the rainfall in this region?
53. In what way does the tropical savanna differ from the tropical rain forest? What is the rainfall? Name a typical savanna region.

54. What is the cause of the excessive rainfall in northern India?

55. Why is Mediterranean climate ideal for tourists? What regions have this climate?

56. How does a moist subtropical climate differ from the Mediterranean type? Name a region in the United States that has this climate. What crops are well suited to the climate?

57. What is the chief characteristic of mountain climate? What differences are found on windward and leeward sides?

58. How do mountain climates differ in the westerlies and in the trades?

59. How does it happen that anything at all will grow in a polar climate?

60. What is the evidence of glacial climates of the past?

61. How can the presence of enormous masses of coral in early Paleozoic formations be explained?

62. What relation do we find between times of uplift and climate?

63. Present evidence to prove that the regions of the United States in which we find our chief coal deposits had a tropical rain forest climate at some past time.

64. What evidence convinces us that the climate of the Great Salt Lake region was at one time humid?

## CHAPTER XXX

### CLIMATES OF THE UNITED STATES \*

★396. **Climatic regions.** Situated in the zone of prevailing westerlies, the climate of the United States is chiefly under cyclonic control. But its wide range in latitude, its variation in distance from the sea, and the difference of altitude of various sections result in climates of all varieties, except savannas and the polar types. Minnesota and Maine have lower temperatures than Florida and Louisiana because they are farther north. Kansas and

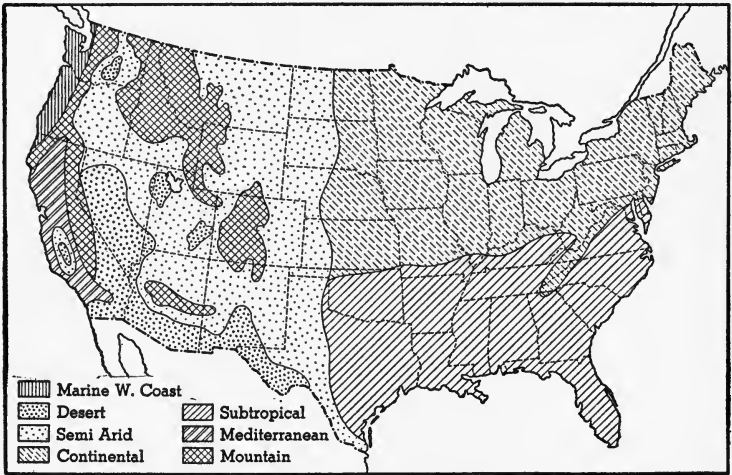

FIG. 294. Climates of the United States

Nebraska, lying in the interior of the continent, have greater ranges of temperature and less rainfall than Oregon and Maryland. Denver, in the foothills of the mountains, has a more equable climate than St. Louis, which is at about the same latitude but at a lower elevation.

The distribution of types of climate can be seen at a glance by inspecting Fig. 294. The Pacific coast region has a marine west-

\* This entire chapter is optional.



coast climate in the north; California is chiefly Mediterranean, with desert here and there, especially in the south.

The Great Basin is chiefly desert and semiarid land.

The rest of the country from the Rocky Mountains to the Atlantic may be divided into two climatic zones: the southern half is humid subtropical, and the northern half, humid continental.

These regions will now be taken up in greater detail.

★397. **The Pacific coast region.** This zone extends inland from the Pacific coast about 200 miles, to the backbone of the Sierra Nevada and Cascade Mountains. Like all regions situated near the sea, it is characterized throughout by an equable temperature. The isotherms, instead of running east-west as they usually do, run almost parallel to the coast (Fig. 295).

The continuation of the Japan Current, the North Pacific Drift, cooled by its long journey through North Pacific waters, washes the entire length of our Pacific coast. The winds passing over this current increase slightly the temperature of the northern coast and lower decidedly the temperature of the southern part, but there is seldom a frost in the lowlands of the southern part of California.

But there is a wide difference in rainfall between north and south. The westerly winds come from the Pacific, laden with moisture at all seasons. In summer they blow upon lowlands warmer than themselves, and therefore yield no rain until they begin to rise up the mountain slopes. In winter the cooler land induces rainfall, even over the lowlands, thus making *winter rains* the most marked characteristic of the Pacific coast. On the coast of Washington, where high mountains are near the sea, we have the greatest rainfall of the United States, more than 100 inches, whereas in southern California, with its coastal plain and its nearness to the high-pressure calms, it is less than 10 inches. The climate of the north, including a little of northern California together with all of Oregon and Washington, is of the marine west-coast type, marked by evenness of temperature throughout the year and by heavy rains concentrated in the winter.

Much of California has a Mediterranean climate, with dry summers and moist, mild winters. Temperatures may drop to 40° F. in the winter, but that is extreme. In the summer 70° F. to 80° F. is the rule; and even if it does reach 95° F., the heat is not oppressive,

owing to the low relative humidity, and the hot days are followed by cool nights, around 60° F. Skies are clear in the summer and one fair day follows another, making this region ideal as a resort.

The cultivated lowlands of the south are parched during the growing season, but, fortunately, their nearness to the mountains makes irrigation possible, and as a result of the unbroken succession of sunshiny days, they are the most valuable fruit lands in the United States.

More and more of the arid lands of California are being reclaimed by irrigation; and, with the completion of the Boulder Dam Project, more than a million acres of the Imperial and Coachella valleys will be under cultivation.

Along the coast fogs are common, especially in winter. Severe storms are almost unknown. Thunder is rarely heard upon the coast; on the mountain slopes thunderstorms break and lightning flashes are seen, but at distances from the coast too great for the sound of the thunder to be heard.

**★398. The arid regions.** This region embraces the Great Basin, the highlands lying between the Sierra Nevada and Cascade Mountains on the west and the Rocky Mountains on the east, as well as the western portion of the Great Plains. Its most marked characteristic is its dryness. It lies on the leeward or western side of the mountains, and the winds from the Pacific, which are forced to rise over these mountains, lose their moisture on the western side and have little rain left for the eastern slopes. Furthermore, as these winds come down from the mountains, they are compressed and therefore warmed, which lowers their relative humidity, and they become drying winds. It is only after they have crossed the greater part of the region and begin their ascent of the western slopes of the Rockies that any rain falls. Occasional cyclonic storms yield some rain, but over much of the region the rainfall is insufficient for agriculture, without irrigation. It varies from 20 inches in Washington to 3 inches in Arizona. Much of the Great Basin is distant from sources of water and must therefore remain arid and uncultivated.

Some of the semiarid lands have been cultivated by "dry-farming," a process which has caused extensive soil erosion and destructive "dust storms," which, it is said, will reduce the land ultimately to a desert. Some of it has been overgrazed by cattle;

in other places the surface cover of grass has been ripped off, to attempt cultivation, and in some cases the unwise use of irrigation has brought alkali to the surface.

The whole process of the utilization of these waste lands has come to the fore again, in connection with dust storms, soil erosion, flood control, irrigation, and water power; and it is being borne in upon us that all these problems are closely connected.

Skies over the Great Basin are prevailingly clear, and the daily range of temperature is great. Winters are cold and summers extremely hot. Cold winter cyclones sweep down from the northwest.

Rainfall is nowhere in the region sufficient to support heavy forests. In the north, where there is rain, it falls mostly in winter, the growing season being almost without rain; but owing to the deep and retentive soil, in which capillary action brings water up from unusual depths, this part of the region yields abundant wheat harvests. Where irrigation is available, apples and other fruits of temperate latitudes are grown.

The chinook winds coming down the mountain slopes, warming as they drop, keep the narrow mountain valleys free of snow. On this account these valleys are much sought by wild and domestic animals for winter grazing.

★399. **The humid subtropical south** includes the south Atlantic and Gulf States as well as Arkansas, Oklahoma, Kentucky, and Tennessee. Winters are temperate and summers are oppressive, because of high humidity rather than heat. The coastal states are bathed by the Gulf Stream, giving them a climate resembling that of the Amazon, which is hot and humid. Temperatures during the day run up to 100° F. Montgomery, Alabama, has a maximum of 107° F. in August; and Savannah, Georgia, 105° F. in July.

The nights are oppressive because of the humidity, and the overhanging clouds prevent the land from cooling off by radiation, in strong contrast to California, where the nights are cool.

Winters are mild, averaging around 50° F., though there are extremes that may bring frost, due to the winter-monsoon effect of the north and northwest winds. In the daytime the temperature may reach 60° F. or even 70° F., and the day is bright and sunshiny, only to be followed by a cloudy day or a cold one, as the wind shifts to the northwest.

Late summer and fall brings possible hurricanes from the south-east, which, fortunately, are not numerous.

Rainfall near the coast is as high as 60 inches, well distributed throughout the season. It is often accompanied by lightning storms of local origin. Florida has over 60 lightning storms a year.

**★400. The humid continental climate of the north.** This region includes the so-called northern states, from the semiarid lands of the Great Plains east to the Atlantic (Fig. 294). It therefore includes the northern part of the Great Plains and Prairies, the Appalachian Plateau, the Piedmont Plateau, and the north and middle Atlantic States.

Most of the region is characterized by cold winters and hot summers, much more extreme in the interior than on the Atlantic seaboard and near the Great Lakes, although the tempering effect of the ocean is not nearly so great as it is on the Pacific. On the Pacific coast the westerly winds blow *from the sea*, whereas on the Atlantic coast the same westerly winds blow from the land to the sea. There is a temperature range of 160° F. in North Dakota, while on the coast it is only half that.

In the west, near the semiarid regions, there are abundant grasslands; but the rainfall, which on the western fringe is only 20 inches, increases to the east, and is everywhere sufficient for agriculture. Most of our farm lands are in this region.

There is a strange and unexplained absence of forest in the prairie lands of the central states, in spite of the sufficiency of rainfall.

Rains and winds are under cyclonic control. In the central regions winds are variable and attain high velocity where unchecked by forest. Winter cyclones come from the northwest. They bring snow rather than rain, especially in the lake region.

Rains are more frequent in the early summer, when the sun's heat starts convectional storms. This is very important for crops requiring maximum water in the early stages of growth.

Winter cold is more extreme than summer heat, and the weather is very changeable, because it is under control of the cyclones sweeping down from the northwest.

The *blizzard* and the *cold wave* are characteristic of the humid continental climate. The blizzard is a high, cold wind, filled to

blinding with a mass of fine snow. It is common enough in the interior and not unknown on the coast.

In a *cold wave* there is a rapid drop in temperature, as much as 20° F. in 24 hours, ending close to 32° F. It is developed at the front of an anticyclone advancing from the northwest.

Weather in the summer is more regular than in the winter. Cumulus clouds are common, and thunderstorms in the afternoon may be frequent, somewhat like weather in the tropics.

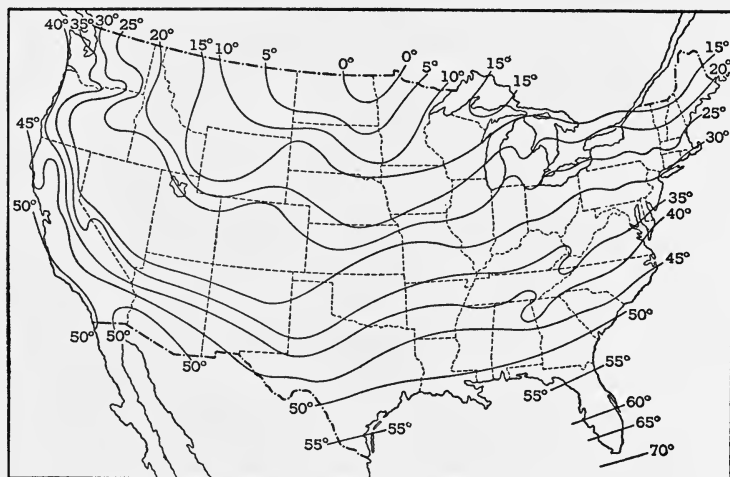

FIG. 295. Isotherms of the United States for January

*Hot waves* result from southerly winds, and the heat wave is broken when the wind shifts to the northwest.

Spring and fall show fickle alternations of summer and winter weather, as cyclones are followed by anticyclones with their low temperature. Fall presents fine clear days and freezing nights. Then come warm spells with a hazy atmosphere, known as *Indian summer*.

These seasons are more characteristic of the northern portions of the continental climate belt than of the southern. The chief difference is the greater length of summer in the corn belt to the south.

★401. **Exceptional climatic conditions.** In defining climate as average weather, it was noted that while that may be true in general, it often happens that the *exceptional* characters of the

weather, rather than the average, are of greater importance. For example, our buildings must be constructed to withstand the *strongest* wind, and our heating systems to provide against the *lowest* temperature rather than the average.

As we have seen, profitable agriculture is dependent not so much upon annual rainfall as upon rainfall during the growing season.

In order to obtain a clear understanding of the climates of the United States, it is necessary to examine maps showing averages

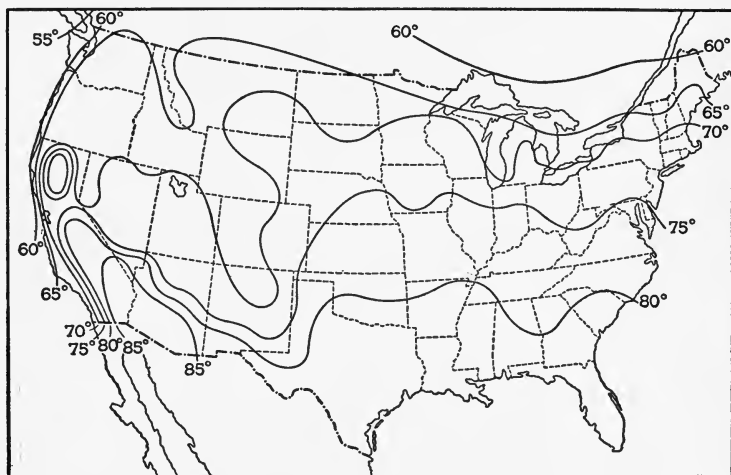

FIG. 296. Isotherms of the United States for July

for given periods as well as maps showing departures from the averages.

From the January chart of temperatures (Fig. 295) one can see the wide difference in the winter temperature of Key West, 70° F., and of North Dakota, 0° F. This difference, while in part due to difference of latitude, is to a much greater extent due to the difference between coast and continental conditions. Along the Atlantic coast the change of temperatures is from 70° F. at Key West to 15° F. in Maine, while along the Pacific coast it runs from 50° F. to 40° F., showing the influence of the marine west-coast climate.

The July temperature chart (Fig. 296) tells a different story. No longer is the highest temperature found at Key West, on the

coast, but in Arizona, which is farther north. This is due to the clear skies of the arid land.

From Florida to Maine, on the Atlantic coast the difference is about 25° F. as compared to 55° F. in January, while on the Pacific coast the difference for July is about the same as for January, the isotherms in both cases running almost parallel to the coast. The interior of the continent, which is colder than the coast in January, is warmer in July.

The lowest temperature in the United States, - 63° F., is reached in the interior of the continent near the Canadian border. Low temperatures on the Atlantic coast are about 25° lower than those on the Pacific coast.

The tempering influence of the sea is again well shown by a comparison of the average of the highest temperatures of the coasts, 95° F., with that of the interior, 105° F. The highest temperature, 125° F., is recorded in the interior desert regions of Southern California and Arizona. Temperatures of 105° and over are common over the Great Plains, but the dry heat is not so oppressive as that of the Gulf and Atlantic coasts, where it is very humid.

The range of temperature is the difference between the summer maximum and the winter minimum. The greatest range is found in the northern interior continental climate, whereas the lowest range occurs at Key West, in a tropical climate. In general, range of temperature increases with increase of latitude and with distance from the sea.

The range of temperature along the Pacific coast varies little, being only 15° F. greater in the extreme north than in the extreme south, while the Atlantic coast varies in range from 50° F. in the south to 110° F. in Maine. The range of temperature for most of the Gulf coast is about 85° F., whereas that for Montana is twice as great.

★402. **Freezing temperatures.** The number of days with average temperatures below freezing varies from none in the Pacific, Gulf, and South Atlantic coast regions, to 165 days in Minnesota and North Dakota. Of much greater interest to farmers and fruit growers, however, are the dates of occurrence of earliest and latest killing frosts.

In the fall, with the lengthening night and increasing slant of

the sun's rays, there comes a time when the daily minimum temperature falls almost to freezing. The passage of a low across the continent is then likely to be followed by frost. This is due to the cold indraft of north winds at the rear of the low, where the sky is clear and the winds light.

The date of the *first* killing frost in the extreme north central part of the United States is about the first of September (Fig. 297). As the winter season marches southward and toward the coasts, the first killing frost occurs later and later in these directions — as

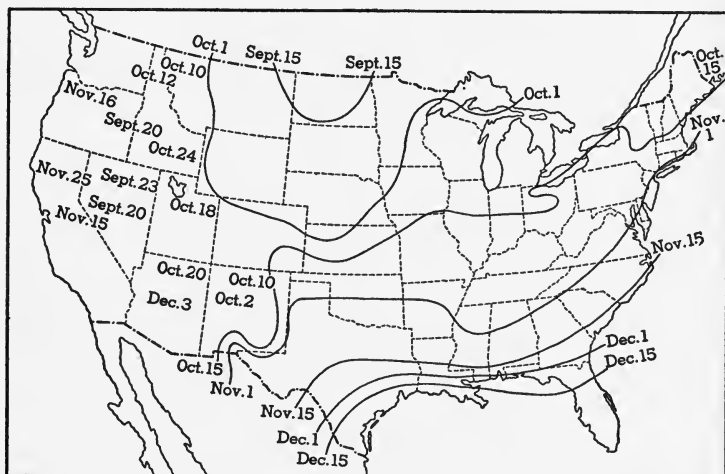

FIG. 297. Date of First Killing Frost

Note its southeast movement.

late as December 15th in central Florida. In spring, when the noon altitude of the sun is increasing and the days are lengthening, there comes a time when it ordinarily does not get below freezing. But for weeks after this, a passing low, with its cold indraft of northern winds behind, may bring freezing temperatures. At such times falling temperatures and clearing skies forewarn of frost.

Since spring moves northward and landward from the coasts, the average time of *latest* killing frost is earliest at the south, and earlier at the coast than inland (Fig. 298). Along the Gulf coast it occurs before February 15, and it is delayed in the extreme north part of central United States until June 1.

The absolute date of latest killing frost is considerably later



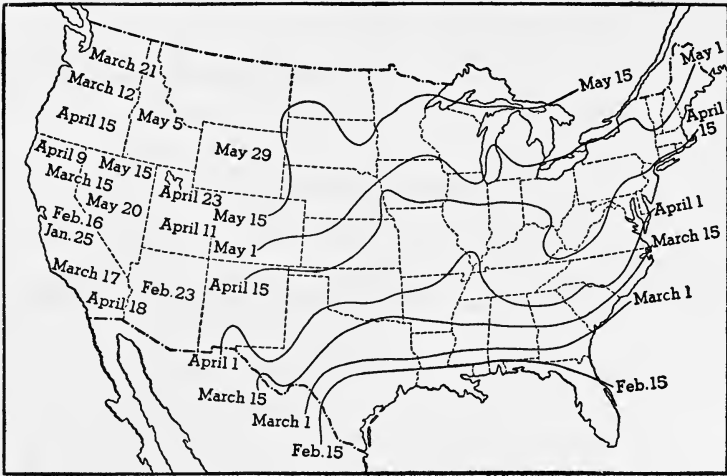

FIG. 298. Date of Latest Killing Frost in Spring  
Note its northwest movement.

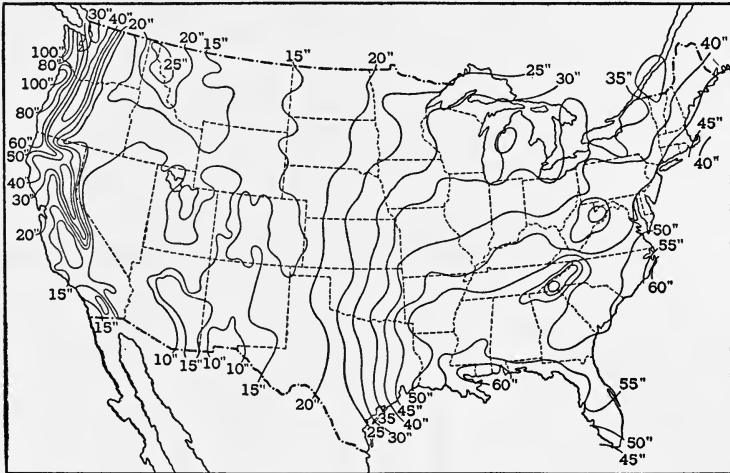

FIG. 299. Average Annual Rainfall in the United States, in Inches  
than the average date in all sections, being much nearer March 1 on the Gulf coast, and July 1 in Minnesota.

★403. **Distribution of rainfall in the United States.** From the rainfall chart (Fig. 299) we are able to locate the regions of greatest and least rainfall during the year.

The least rainfall, 3 inches, occurs in southwestern Arizona. Most of this amount may fall in a single day, or indeed, in a few hours during a single thunderstorm.

The greatest annual rainfall in the United States, more than 100 inches, occurs in northwest Washington, and while most abundant in winter, is fairly well distributed throughout the year. The annual rainfall on the Pacific coast decreases southward; in central California it is less than half that in Washington. On the Atlantic coast the maximum rainfall is near Cape Hatteras, decreasing northward and southward.

For agriculture, a rainfall of two to four inches per month is desirable during the growing season. Sometimes it rains more than that in a single day. Such torrential downpours are injurious to crops and to the land. The soil is washed away, and streams are flooded and overflow their banks, causing destruction of life and property. Such heavy downpours are known as *cloudbursts*.

The recorded rainfall includes snowfall; 10 inches of snowfall is estimated as equivalent to one inch of rain.

**404. Distribution of snow.** Every part of the United States, except southern Florida and southern California, receives some snowfall. It is least at the south, although occasional heavy snowfalls occur there. It is more than 40 inches in the region of the Great Lakes and in the Rocky Mountains. A fall of 13 inches occurred at Baton Rouge, Louisiana, during a single storm in February, but such snows usually melt within a day or two after falling.

The greatest annual snowfall in the *lowlands* of the United States, 130 inches, occurs in the northern peninsula of Michigan; the moisture is supplied from the adjacent lakes. The greatest average annual snowfall of the entire country, not including Alaska, occurs in the Sierra Nevada Mountains. The moist westerlies from the Pacific, compelled to rise in passing over the mountains, precipitate, on an average, 378 inches of snow at Summit, California.

The Rocky Mountain region has a heavy annual snowfall, though less than the Sierra Nevada and Coast ranges. It is mainly the melting of these snows in the Rockies that furnishes the great irrigation projects with their supply of water. The floods in the Missouri, and other eastward-flowing streams with sources in these

mountains, occur in May and June, when the normal rainfall is augmented by the melting snow.

The snowfall in the northern plains and prairie regions is variable. Some winters it is excessive; others, light. When abundant in the wheat-growing sections, a good crop is expected, since the snow serves as a protection from the cold, and also leaves the soil in good condition.

In the lumbering sections of the north, from Minnesota to Maine, the profits of the season are directly related to the snowfall, because the lumber is moved on sledges over the snow.

★405. **Number of days with precipitation.** The number of rainy or snowy days during the year varies widely in different sections of the country. In general, it is least in the interior and increases toward the coasts, and is greater in the north than in the south. The greatest number, 180, occurs in northwest Washington; then follows the Great Lakes region with 170 days. In the southwest desert region the number falls to 13. For most of the agricultural sections the number varies from 100 to 140. Forty consecutive rainy days are reported in northwestern United States, and 150 days of consecutive drought in the arid region of the southwest.

★406. **Humidity.** The absolute humidity of the air is greater in southern United States than in northern; it is greater in summer than in winter, and greater near the coast than in the interior.

The relative humidity is, on an average, lowest on the Colorado plateau, where it is about 40%, and highest on the eastern and western coasts, about latitude 40° N., where it is about 80%. In the Gulf region it is about 75%, and approximately the same in the region of the Great Lakes, although, as a rule, continental interiors favor low relative humidities.

The percentage of cloudiness agrees well in winter with the relative humidity, but in summer one of the areas of greatest cloudiness is over the Colorado plateau, where the average relative humidity is low. This is probably due to the strong convectional currents set up during the summer season when the air rises to heights sufficient for saturation.

★407. **Winds.** As before stated, the winds are stronger on the coast and over the prairie regions than over forests and mountainous regions. For most of the country the season of strongest winds is spring, and the month of weakest winds is August.

Aside from tornadoes and hurricanes, during which, for a few seconds, the velocity of the wind may exceed 100 miles per hour, the strongest winds are about 70 miles an hour inland, and 90 miles an hour on the coast.

Though the direction of the wind is variable in all parts of the United States, in valleys, there is a decided up or down the valley tendency in wind direction. On the coasts, in winter there is a predominance of land winds. This is especially true of the Gulf and Atlantic coasts. On the Pacific coast the meeting of the land winds and the prevailing westerlies produces "along shore" winds. In summer the conditions upon the Atlantic and Pacific coasts are reversed. The Pacific then has strong ocean winds, while the in-blowing winds upon the Atlantic coast are met by the westerlies, and "along shore" winds from the southwest are produced.

The winds which bring cloudy weather and precipitation vary with the section. They are generally winds blowing from the nearest great body of water. On the Atlantic and Gulf coasts, and over most of the interior of the United States, they are east and southeast winds, while on the Pacific coast they are generally southwest winds. In winter, in the northern section of the United States snow often accompanies winds from a northerly direction. Winds from southerly directions, in front of the low, bring higher temperatures and yield rain, while the colder winds in the rear yield snow.

### *Completion Summary*

The chief climatic control of the United States is ———. The Pacific coast has ——— climates: in the north ———, and in the south ———.

In the Great Basin the climate is ———, practically all over. The country to the east of the ——— is ——— in the north; and along the southern coasts ———.

The prevailing westerlies give the west coast an ——— climate. In the north it is of marine west-coast type, with winters ———; in the south the climate is Mediterranean, with ——— summers and ——— winters. The prevailing westerlies, rising over the mountains, drop ——— on the western side of ——— and as they descend on the eastern slopes, they are dry; hence the arid region ———. These chinook winds provide ——— good for grazing.

The coast regions of our southern states have \_\_\_\_\_ climate. Humidity \_\_\_\_\_ and the summers are therefore \_\_\_\_\_ for human beings. Lightning storms \_\_\_\_\_, and hurricanes \_\_\_\_\_.

Most of the northern and eastern states have \_\_\_\_\_ climate. The winters \_\_\_\_\_ and the summers \_\_\_\_\_. Weather is \_\_\_\_\_ because under \_\_\_\_\_ control. Blizzards, cold waves, hot waves, and thunderstorms are phenomena of \_\_\_\_\_.

In studying the climate of a region, exceptions from the averages are sometimes more important than the averages themselves. Variations in the interior are great, especially in temperature. On the coasts it is much less, but the Atlantic coast varies \_\_\_\_\_ than the Pacific, because of the \_\_\_\_\_.

The greatest annual rainfall, amounting to \_\_\_\_\_, is \_\_\_\_\_; the least, \_\_\_\_\_, is \_\_\_\_\_.

Snowfall is heavy in \_\_\_\_\_ regions as well as \_\_\_\_\_.

### *Exercises*

1. What is the chief climatic control in the United States?
2. What factors cause variations in the climate of the United States?
3. What are the climates of the Pacific coast?
4. Why is the Great Basin chiefly arid?
5. What are the climates of eastern United States?
6. Why do the isotherms of the west coast run parallel to the coast?
7. What effect has the North Pacific Drift on our west coast climates?
8. Why does the west coast have most of its rains in winter?
9. Explain the difference in rainfall between Washington and southern California.
10. Describe the climate of California.
11. Why is southern California so well suited to fruit growing?
12. What advantages does the Boulder Dam Project bring to California?
13. Follow the prevailing westerlies from the ocean across the west coast and over the Great Basin, and explain the rainfall of the regions over which these winds blow.

14. Describe the destructive effects of dry farming on the semi-arid lands.

15. Describe the climate of the Great Basin.

16. Why is it said that the problems of dust storms, soil erosion, flood control, irrigation, and water power are closely connected?

17. How do chinook winds affect the climate of the valleys in western mountains?

18. How does the Gulf Stream affect the climate of the south Atlantic and Gulf States?

19. Why are summer nights hot in the Gulf States and cool in California, at about the same latitude?

20. How do the winter monsoons affect the climate of the southern states?

21. What is the cause of the prevalence of lightning storms in Florida?

22. What is the climate of the south?

23. What is the climate of the north?

24. Why is the humid continental climate more extreme in the interior than on the Atlantic coast?

25. Why is it that the Atlantic Ocean has not nearly so much effect on the climate of the coast as the Pacific?

26. Where is the greatest temperature range in the United States? Explain.

27. What is the range of rainfall in the northern states?

28. Why are the northern states our chief agricultural lands?

29. Account for the changeable weather of the northern states.

30. What is a blizzard? In what regions is it common? Why?

31. What is a cold wave? Where is it common? Why?

32. What is Indian summer? When and where do we get it?

33. How does the southern part of the continental humid climate belt of the United States differ from the northern part?

34. How do you account for the greater range of temperatures on the Atlantic than on the Pacific coast?

35. Where do we find the highest temperatures in the United States? the lowest?

36. What is the date of the first killing frost in the northern states? in Florida?

37. How may a cyclone produce a frost in spring?

38. Where do we find the greatest rainfall in the United States?  
Why?
39. Where do we find the least rainfall in the United States?  
Why?
40. What is a cloudburst?
41. What rainfall is ideal for agriculture?
42. Where is the greatest annual snowfall? How much?
43. Why does abundant snowfall presage good wheat crops?
44. In what region do they have the greatest number of days  
of precipitation?
45. What is the reason for the cloudiness on the Colorado  
Plateau in summer, although the relative humidity is low?
46. Why are thunderstorms practically unknown on the west  
coast?
47. From what direction do storms in your region usually  
come?
48. What direction of wind is most likely to bring snow in  
winter?
49. What is the yearly rainfall in your region?
50. What is the yearly range of temperature in your section?

## CHAPTER XXXI

# GENERAL CHARACTERISTICS OF THE SEA

**408. The relation of the sea to the land.** The sea wears away the land, at its margins, by wave action; and indirectly the erosion of the land depends upon the sea in two ways. (1) The water which falls as rain is derived from the sea by evaporation; and (2) the level of the sea determines the velocity of the running water which brings about erosion of the land.

The sea is a great international highway and plays an important part in the trade of the world. It is no longer a barrier between nations, since great steamships are little affected by storms. Equipped with radio, ships communicate with each other and with stations on land, and this removes the isolation that was formerly experienced in crossing great oceans.

The digging of canals across isthmuses tends to change routes of travel and commerce at sea. The Suez Canal shortened the route from Europe to India and China, and the Panama Canal has cut by thousands of miles the sea distance between New York and San Francisco.

The surface of the sea is commonly regarded as having a very nearly uniform level, known as "sea level," from which land elevations and sea depressions are measured. When large mountain masses are situated near the coast, their gravitational attraction draws the sea up on the land and thereby upsets the uniform level of the sea. This change in level may amount to several hundred feet in different parts of the earth. On the coast of India near the Himalaya Mountains, the water stands much higher than water in mid-



ocean or water along a lowland coast like western Europe or eastern United States.

★The area of the earth's surface covered by the sea has changed constantly during past ages, but since the Rocky Mountain Uplift at the end of the Mesozoic Era, about 60 million years ago, the continents have assumed practically their present outlines.

Most of the land is covered by sedimentary rocks, which proves that it was at some time covered by the sea, and some of the present sea bottom has at one time been land.

The Mississippi Valley and central Canada have several times been drowned, all the way from the Gulf of Mexico to the Arctic. On the other hand, the east coast of North America extended several hundred miles farther out than it does now, being occupied, in fact, by an extensive range of mountains; and again, recently the present coast has been drowned.

**409. Divisions of the sea.** The continuous body of salt water called the *sea*, covering about three fourths of the earth's surface, has five divisions called *oceans*.

The *Pacific* is the largest ocean, comprising three eighths of the sea area. Its greatest width is about 10,000 miles at the equator. On its Asiatic shores it is characterized by numerous border seas, islands, and many rivers; and on its American shores, by high mountain ranges parallel to the shore, but by few rivers.

The *Atlantic* is second in size, with an area about one quarter of the sea area. Its average width is 3,600 miles. The North Atlantic (north of the equator), on both the American and European shores, has many bays which give it an irregular shore line with many good harbors. The coasts slope gradually toward the sea and there are many rivers. The South Atlantic has a more regular shore line with few good harbors.

The *Indian Ocean* has an outline that is roughly circular. It has one eighth of the total sea area and a diameter of about 6,000 miles. The Indian Ocean is bordered by large bays, and has a northern and western boundary of very high mountains.

The *Arctic Ocean* is an extension of the Atlantic. It has a width of about 2,500 miles. It occupies about one thirtieth of the sea area; the greater part of it is covered most of the year with drifting ice. The water at the center of the Arctic Ocean, near the North Pole, is nearly two miles deep.

The *Antarctic Ocean* lies within the Antarctic Circle. In this region there is a continent covered by an ice cap thousands of feet thick; in other words, *there is a glacial epoch in the Antarctic.*

The South Pole is located on land with an elevation of two miles. The continental glacier, thousands of feet thick, is the source of the icebergs of the southern seas, just as the glacier covering Greenland furnishes the icebergs of the North Atlantic.

**410. Distribution of the ocean waters.** The greatest expanse of water is in the Southern Hemisphere; the island of New Zealand is at the center of the water hemisphere. London, England, almost exactly opposite New Zealand on the globe, is the center of the great land area of the earth.

**411. Deep sea basins.** Before the seas existed, the continents must have been formed of huge masses of granitic rock, which, being of lower density than the basaltic rocks, floated higher in the dense liquid earth mass. The basalt was of larger quantity, and therefore the sea bottom, which seems to be basalt, is of greater area than the land mass.

The continents must at one time, then, have existed as great plateaus, three miles above the ocean floor.

The average depth of the sea is 2.5 miles, with a maximum depth of almost 7 miles in the Swire Deep, east of the Philippine Islands.

The sea bottom is much more regular than the land surface, owing, no doubt, to the fact that the land surface is being continually eroded, while there is no such process on the sea bottom; quite the contrary, deposition is going on there. Here and there we find mountain peaks, most of which are volcanic cones. In other places are corresponding *deeps*,

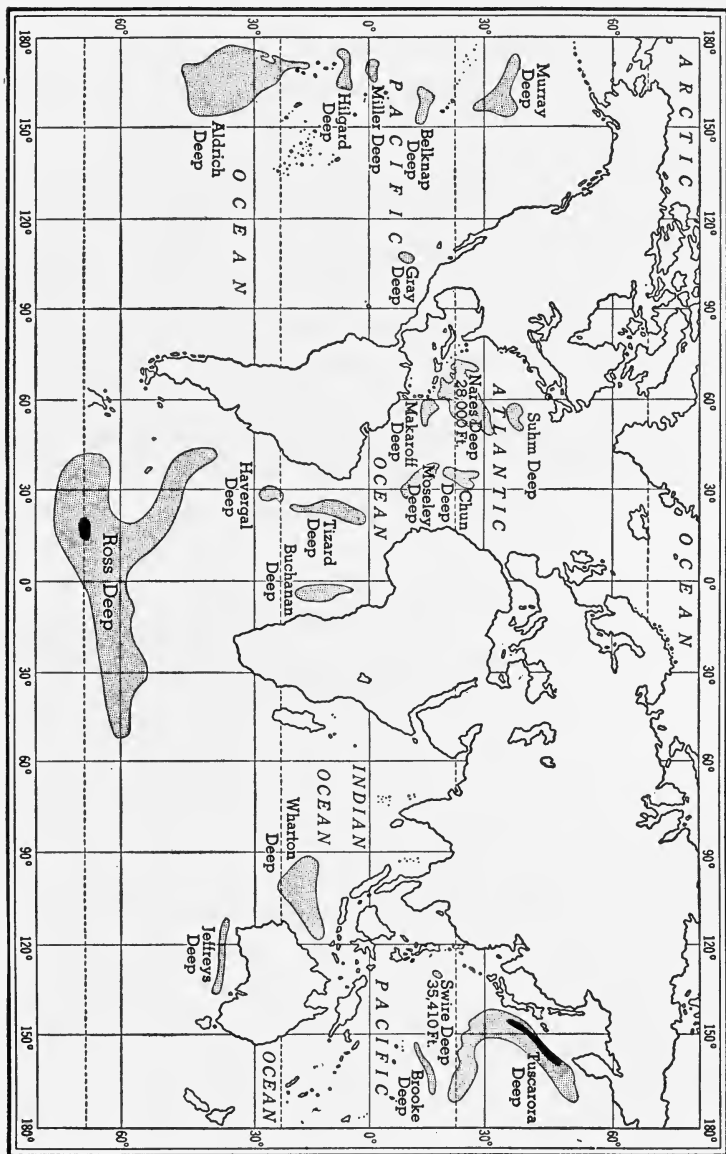

Fig. 300. The Ocean Depths

many of them parallel to mountain ranges on the continents, and possibly complementary to them. Such, for example, is the Tuscarora Deep, about 28,000 feet deep, parallel to the Japanese Mountains.

In the Atlantic Ocean we have the Nares Deep, off Porto Rico, about 28,000 feet deep. Over 50 of these deeps are known (Fig. 300).

**412. The continental shelf.** The seas in many places are overflowing their basins and flooding a portion of the continental mass, called the *continental shelf* (Fig. 301). This slopes gently toward the deep ocean so that the water on the shelf is shallow, not more than 600 feet. It is here that the sediments brought down by the rivers are de-

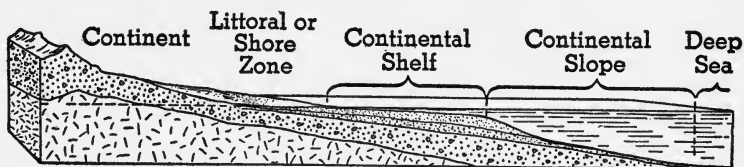

FIG. 301. The Marine Zones

posited and smoothed out in horizontal layers, which, when they become consolidated, form sedimentary rocks. It is the continental shelf which is sometimes uplifted to form a coastal plain. Continental shelves are well developed along the eastern coasts of North and South America, in places more than 100 miles wide. On the western coast they are much narrower. The British Isles are on the continental shelf of northern Europe. There is evidence that much of the continental shelf has been above the sea level. Several of the valleys of large rivers flowing into the Atlantic may be traced seaward, across the continental shelf, by valleys or canyons which were formed by the river when the continental shelf was dry land.

**413. Composition of the sea water.** About 3.5% of the sea water consists of dissolved salts. About three fourths of this is common salt (sodium chloride). The bitterness of sea

water is due to magnesium chloride and sulphate (known as Epsom Salts) and calcium sulphate, called gypsum. Beside these, there is a little magnesium bromide, potassium iodide, and calcium bicarbonate. From the last, marine animals fashion their shells of calcium carbonate; and it is this which ultimately accumulates and forms limestone.

There are about 30,000 million million tons of salts in the ocean, enough to cover the entire earth with a layer 150 feet thick. The Mediterranean and other inland seas have a higher salinity than the oceans, especially where the evaporation is greater in the trade-wind belts.

The sea is getting more salty as time goes on, because the rivers constantly bring more salt from the land, while evaporation carries away only pure water.

★Attempts have been made to estimate the age of the oceans by calculations based on the amount of salt and on the rate at which rivers deliver salt to the sea. The following equation will show how this is done.

$$\text{Age of seas} = \frac{\text{total salt in seas}}{\text{salt in rivers per year}}.$$

On this basis the age of the ocean turns out to be something less than 100 million years. But the assumption is here made that the amount of salt carried to the sea has been the same, year by year, whereas it is more than likely that this is not true; that in the beginning much salt was dissolved out of the rocks and it is becoming less and less. On that basis the age of the seas is much greater than 100 million years.

**414. Sedimentary deposits in the sea.** The rivers are constantly bringing vast quantities of sediment and dissolved salts to the sea. Waves cut into the land and add more, and some is contributed by the wind. The solid matter thus received is assorted, transported, and deposited in beds which ultimately become sedimentary rocks. These deposits, consisting of gravel, sand, and mud, are dropped on the continental shelf.

Gravel beds are found at the mouth of a swift river, since

the river must drop the heavier pieces as soon as its velocity is checked by the sea. Gravel may also be found where wave action is violent. Sand may extend out many miles from shore. Mud beds made of the finest particles are located beyond the sands in the open sea or in the quiet water of bays; for only there can the finer matter settle.

★A large part of the dissolved calcium bicarbonate of sea water is taken up by plants and animals. The plants, particularly calcareous algae, extract the carbon dioxide from the bicarbonate in the water. Animals decompose the bicarbonate and use the calcium carbonate thus formed in constructing their shells. These processes take place only in warm, clear, shallow waters, because sunlight does not penetrate muddy water or very deep water; hence plants cannot grow, and if there are no plants, animals cannot thrive.

It is therefore on the continental shelf, in water less than 600 feet deep but not very near the shore, that most marine life thrives. In this zone, therefore, limestones are formed from the precipitated calcium carbonate of plants and the shells of animals.

There is no sharp line of division between gravel, sand, mud, and shells, but these grade into one another, and, of course, the same gradation will be found in the sedimentary rocks formed from those deposits, which will be conglomerate, sandstone, shale, and limestone.

None of these sediments reach the deep sea unless they are carried by the wind. Wind-blown deposits include some surface soil from the land, pumice and other volcanic ash, and particles of meteoric iron; but most of the deposits of the deep sea are skeletons of tiny floating animals; all of the deposits make up a fine mud, called *ooze*. Much of it is *globigerina ooze* because of the preponderance of microscopic globigerina. Much of this ooze is red from the iron compounds.

**415. Temperature of sea water.** The surface water of the sea is warmest; and since warm water is less dense than cold water, it remains on the surface. In polar regions the cold

air cools the surface water, which sinks. The bottom water may be as low as 29° F. in the sea, while in a lake made of fresh water it can never get below 39° F., at which the fresh water reaches its maximum density. At the equator the temperature of the surface is about 80° F., while in enclosed seas it may rise as high as 95° F.

At New York the winter temperature is about 55° F. and the summer temperature about 65° F.

With increasing depth the water gets colder. Even near the equator the temperature, at less than half a mile, is below 40° F., while at the bottom of the sea the temperature is about 35° F. Ocean currents cause irregularities in temperature: the cold water from the poles creeps along the bottom toward the equator.

**416. Ice in the sea.** When sea water is cooled, the ice that first forms, at 32° F., is pure and free from salt. Then the salt water freezes at about 27° F., the temperature depending upon the per cent of salt.

In the colder regions ice forms along the shores and also on the deep sea, often to a thickness of 8 or 10 feet.

The ice formed in the winter is usually broken in pieces in the summer. These floating pieces, called *field* or *floe ice*, are often crowded and jammed together into an *ice pack*, which, because of lateral pressure, is raised considerably above the water. This sea ice may be driven upon the land by waves and tides and become 20 feet thick by accumulation of snow. Rock fragments from overlying cliffs and from the shore are picked up by this ice, which is known as an *ice foot*. In winter the grinding of this ice foot, up and down the shores, smooths and rounds the rocks of these coasts. In the summer it melts, breaks up, and scatters the rocky material, often over long distances.

Glaciers entering the sea from the land in polar regions break off at the shore and send off large masses of ice, known as *icebergs*. Some icebergs are a mile or more in length and 500 feet above water. As ice is about nine tenths as dense as

water, nine tenths of the mass of the iceberg is below the surface of the water.

These icebergs transport boulders and pebbles and drop them on the sea bottom in the warmer and more open seas. Some geologists have regarded the Grand Banks, off Newfoundland, as due to deposits from icebergs.

In the Southern Hemisphere icebergs have been encountered north of the Falkland Islands and also near Cape Horn.

In the Northern Hemisphere icebergs are frequently seen near the Newfoundland Banks and reach farthest south, near New England, in May and June. They are dangerous because the most frequented ocean lane passes through this region. Since 1912, when the Titanic sank after collision with an iceberg, the United States Coast Guard has maintained a patrol in the dangerous zone. The patrol has been so effective that not another life has been lost in this way. From September to January there is no ice to be seen in these waters.

### *Completion Summary*

The sea is divided into five oceans: \_\_\_\_\_, \_\_\_\_\_, \_\_\_\_\_, \_\_\_\_\_, and \_\_\_\_\_.

The edge of the continent covered by the sea is called \_\_\_\_\_. The important part of the shelf, where \_\_\_\_\_ rocks are formed, is not deeper than \_\_\_\_\_.

The rest of the sea bottom consists of the \_\_\_\_\_, on which no sedimentary rocks are formed.

Sea water contains about \_\_\_\_\_% of dissolved \_\_\_\_\_, including \_\_\_\_\_ salt, \_\_\_\_\_, and \_\_\_\_\_. These were formed from weathering and solution of \_\_\_\_\_ of the land and brought down to the sea by \_\_\_\_\_. The sediments brought to the sea are deposited in \_\_\_\_\_ near \_\_\_\_\_, the coarse \_\_\_\_\_, the sands \_\_\_\_\_, and the muds \_\_\_\_\_. Farther out, where the water \_\_\_\_\_, limestone is formed.

The surface waters of the sea have \_\_\_\_\_ temperature.



Farther down the temperature ———. At latitude 41° N, near New York, the temperature in winter is ——— and in summer ———.

Where Arctic glaciers ——— sea, they ——— icebergs. These are ——— to shipping.

### *Exercises*

1. In what two ways does erosion of the land depend upon the sea?

2. What evidence is there that the land was ever submerged by the sea?

3. What is the relation between the sea and the oceans?

4. What part of the earth's surface is at present submerged?

5. Name the oceans.

6. How does the Pacific differ from the Atlantic in shore lines?

7. State a theory to account for the sea basins with the continental masses at higher elevations.

8. How does the sea bottom differ in profile from the surface of the land?

9. What is a *deep*? Name one, giving its depth and location.

10. What is the relation of the continental shelf to the sea and to the land?

11. What evidence is there that the continental shelf was dry land at some past time?

12. Name three salts present in sea water. Which one is the source of an important rock?

13. Why is the sea becoming more salty?

14. Where are sedimentary rocks formed?

15. In what relation to the shore and to each other do we find the different sediments? Why is this so?

16. What is the chief deposit of the deep sea?

17. Compare the surface temperature of sea water with that at the bottom, near the equator and in polar regions.

18. What is the variation in temperature of the surface of the sea in temperate regions?

19. Why is the temperature of the sea so low at the bottom?

20. How could pure water be obtained from the sea in cold regions?

21. What is an ice foot?
22. How are icebergs formed?
23. How has the danger from icebergs been overcome?

**★Optional Exercises**

24. Give evidence to support the statement that the sea has time and again flooded the land.
25. Show how the age of the earth might be calculated from the amount of salt in the sea. Is this really the age of the earth?
26. Why is limestone always found rather far offshore; at least farther out than shale?
27. Why do we never find sandstone, conglomerate, or limestone in deep sea deposits?
28. Discuss marine erosion due to ice in the polar regions. What deposits may result from this erosion?

## CHAPTER XXXII

### MOVEMENTS OF THE SEA

**417. Waves.** A gentle breeze causes ripples to form on the surface of the water over which it blows; a strong wind changes these ripples into great waves. But it is not the mass of water which moves forward, only the wave motion; just as the up and down movement of the hand holding one end of a loose rope, the other end being fastened to a wall, causes a wave to travel along the rope. The rope does not move forward, only the wave motion. So with a water wave: the water particles move chiefly up and down, while they pass their motion on to neighboring particles of water, and

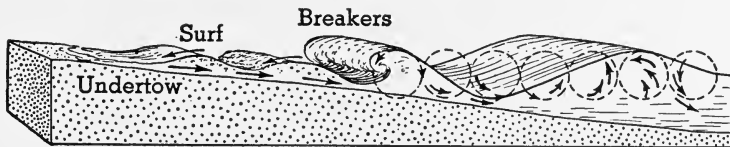

FIG. 302. Movement of Water Particles in a Wave Advancing on the Shore

return to their former positions. Since water is not so rigid as rope, however, there is some forward motion of the particles. This may be observed by examining a small boat as a wave approaches and passes. The boat merely rises and falls while the wave moves by. This is illustrated in Fig. 302.

The forward motion of the water is most rapid in the crest of the wave, and the backward motion is most rapid in the trough. The forward motion is slightly in excess of the backward motion and because of this, when winds are steady in the same direction, currents are produced which flow in the same direction as the wind.

On the front of the wave the water rises and on the back

of the wave the water falls. As the wave moves, new water enters in front and leaves on the back of the wave.

**418. Size of waves.** During a storm, waves may be as much as 500 feet long, measured from the crest of one wave to the crest of the next; and up to 50 feet high, from the crest to the trough of one wave. The height and force of the waves depend upon the force of the wind, the length of time it continues to blow, the depth and breadth of the water, and the form and direction of the coast line. In small bays the waves can never be so high as on the open sea.

**419. Groundswell.** High waves are often driven from an area of storm winds into a region of gentle winds, hundreds of miles away. They diminish in height but keep their velocity and length. They are known as *groundswells*.

**420. Breakers.** When a wave approaches a gently sloping shore, the wave length is diminished and the wave height is increased. The front of the wave, because of lack of water, becomes steeper than the back; and as the wave continues to move into water of less depth, the crest curls, falls forward, and forms a line of *breakers*. The water now moves forward. The loose material of the bottom is churned up and piled higher and higher, forming a sand bar at the line of breakers.

Rocks or bars near the surface of the water may be located by the breakers, which therefore are a warning of danger.

The height of the wave determines the place where it will break, since a wave extends as much below the surface as it does above. A high wave will break farther out than a low one.

**421. Surf and undertow.** When the waves break on the shore, the water is thrown forward and runs up on the beach as surf; and it returns along the bottom as a current called the *undertow*. When the waves reach the shore obliquely, a *longshore current* is formed (Fig. 303).

**422. Pounding of the waves.** Waves are agents of erosion, that is, they break and grind material along the shore and

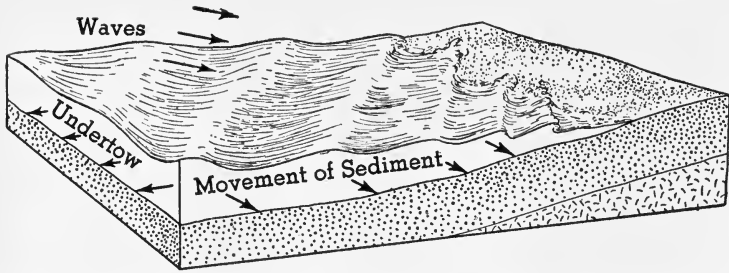

FIG. 303. When the waves advance on the shore obliquely, longshore currents are formed which move sediments parallel to the shore.

transport it small distances. The work of breaking and grinding is done by the impact of the breakers along the shores. In summer, in the Atlantic the average blow of a breaker is about 600 pounds on every square foot of surface. In winter this rises very much, ranging from 2,000 to 6,000 pounds per square foot.

The impact of the water alone accomplishes some erosion, but the chief work of the waves is accomplished with the aid of rock fragments, sand, pebbles, and boulders, which the waves move along or pick up and dash against the cliff. The mixture of water and rock acts like a hammer and sometimes like a file, breaking and grinding the cliff as well as rounding off the pieces of rock used as tools.

Weak rocks exposed along the shores are broken down and removed. The more resistant rocks are loosened by undercutting and, because of the joints in the rock, fall as angular blocks (Fig. 304). These in time become rounded and reduced in size. Large masses of rock, too large at first to be moved by the waves, are reduced by the pounding of smaller fragments, which the water drives against them, until they, too, are shattered. Then the waves use these new fragments as tools. Thus, huge masses of rock are reduced in turn to boulders, pebbles, sand, and finally to silt, which can be carried by the undertow.

**423. Features developed by wave erosion.** The work of the waves at the cutting level may be compared to that

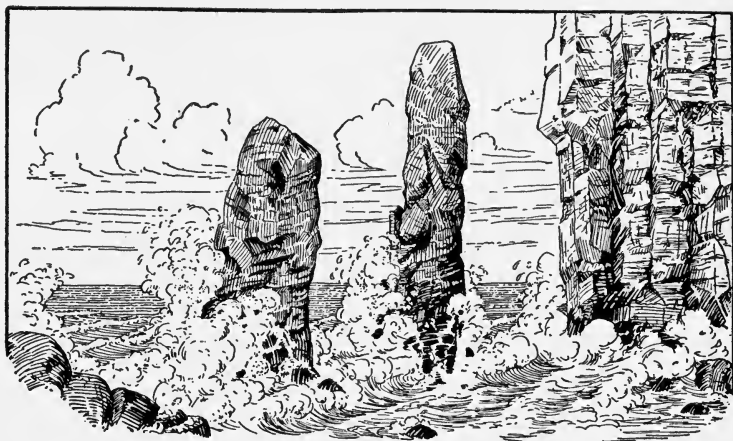

FIG. 304. Chimney Rocks or Stacks

of a horizontal saw. They cut a notch in the cliff and the unsupported rock finally falls, leaving a steep face known as a *sea cliff*. As the blocks are reduced in size to finer and finer material, a *beach* is formed at the foot of the cliff.

If there are vertical joints, the waves will widen them, removing blocks and leaving here and there isolated columns called *chimney rocks* or *stacks* (Fig. 304). The "Old Man of Hoy" on the coast of the Orkney Islands is an example. If the joints are irregular, sea caves and arches may be formed (Fig. 305).

As the waves do their work of erosion, like a horizontal saw, a tablelike surface of rock is left behind, called a *wave-cut bench* (Fig. 306). Pieces of rock dragged back and forth along the wave-cut bench continue to cut it down and smooth it off (Fig. 306). The fine matter covers the bench to produce a beach between the high- and low-water marks. This debris is finally dragged so far out that it is no longer subject to wave action, and there it is piled up into a *wave-built terrace* (Fig. 306).

This terrace is finally built up high enough for waves to

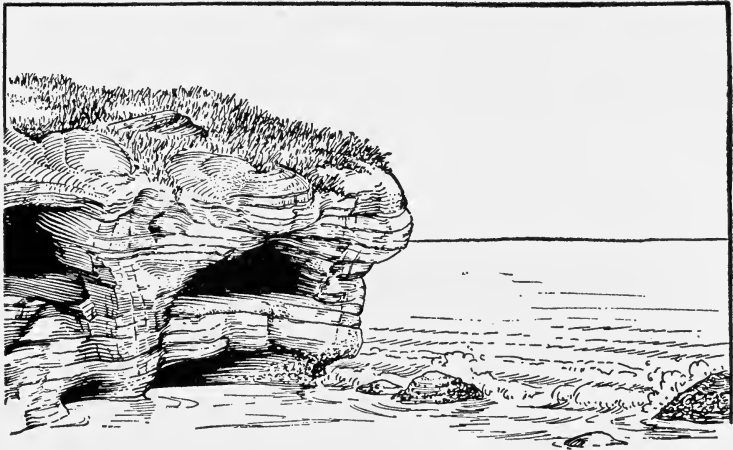

FIG. 305. Sea Caves

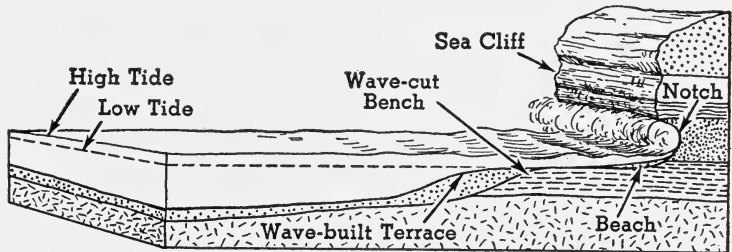

FIG. 306. Some of the Features Developed by Wave Erosion on the Shore

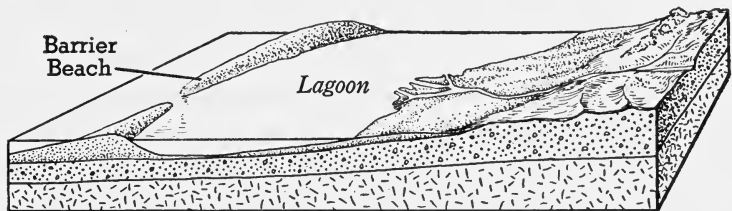

FIG. 307. A Barrier Beach Built by Wave Action

churn it up and pile it higher into a low ridge at the line of breakers. This feature is a *barrier beach*, which may be built up above the surface, parallel to the shore, by storm waves (Fig. 307). Between the barrier and the shore a body

of quiet water, called a *lagoon*, is trapped. Rockaway Beach, on the south shore of Long Island, is a barrier beach. It is growing westward because of longshore currents.

The free end of a barrier beach is called a *spit*. It is often curved inward by currents, and often built across a bay, entirely closing it and interfering with navigation. Sandy Hook, near the entrance to New York Harbor, is a spit. Deposits brought down by streams help to fill up the bay or lagoon.

At the entrance to New York Harbor, for example, dredging is necessary at all times, to deepen the channels through which large boats pass. A fleet of dredges is constantly at work, not only in the bay but also in the narrow arm of the sea called the East River.

Small irregularities in the shore line develop because of differences in the resistance of the rocks and in their exposure to the attacks of the waves; but, as a rule, the shore line becomes more regular, since the more exposed headlands are worn away, and bay heads and lagoons are filled in by rock waste from the shore and also by deposits brought by streams and emptied into the lagoon (Fig. 308).

**424. Tides.** Along the shores of the ocean and its gulfs and bays, the water rises slowly for about 6 hours and 13 minutes, and then falls slowly for about the same time, making an average of 12 hours and 26 minutes from high water to next high water, or from low water to next low water. *This periodic rise and fall of the level of the sea, twice in every 24 hours and 52 minutes, constitutes the tides.*

This makes the hour of high water at any particular place vary from day to day. If it is high water at the ocean shore this afternoon at 4 o'clock, the next high water will occur at 4:26 tomorrow morning, again at 4:52 tomorrow afternoon, and so on.

**425. Variation in tidal range.** The amount of rise and fall is greater along most continental coasts than in mid-ocean, and is greatest in bays which have broad openings to



the sea and are narrow toward their heads. The *tidal range* at Key West, Florida, is usually not more than 2 feet, while in the Bay of Fundy it is often more than 50 feet.

The amount of the rise and the fall of the sea, at any particular place, also varies. The tidal range may increase from day to day for about a week and then decrease for the same period, making a maximum and minimum range twice a month. At Governor's Island, in New York Harbor, the tidal range may be as small as 3.4 feet and as great as 5.3 feet, during a single week.

#### 426. Flood and ebb tides.

The change of level of the sea is accompanied by tidal currents called the *running of the tides*. When the tide is running from the open ocean into bays, it is *flood*, or incoming, *tide*; when the tide runs to the open ocean again, it is the *ebb*, or outgoing, *tide*. During the few minutes when the flood tide changes to ebb tide, or ebb to flood, *slack water* occurs.

**427. Tidal races.** When the tidal currents pass through a strait, such as a narrow inlet into a bay, or between an island and the mainland, the currents often run many miles an hour. Such currents are called *tidal races*, and are often so strong as to interfere with navigation. The tidal currents "race" through Hell Gate, the narrow passage from the



a

A barrier beach has been built up by the waves.



b

Storm waves erode the outer edge of the barrier beach and hurl the sediment over into the lagoon. Streams are filling the lagoon with delta deposits, while vegetation encroaches from all sides.



c

The waves have deepened the water offshore, dragging the sediment farther out and destroying the barrier beach. The shore line is regular.

Once more the waves begin their attack on the cliff.

FIG. 308. Straightening of the Shore Line by the Waves

East River into Long Island Sound, at the rate of 5 or 6 miles an hour.

**428. Tides in rivers.** The tidal wave often runs up rivers to a point many feet above sea level. The tide runs 150 miles up the Hudson River to Troy, 5 feet above sea level, where the tidal range is more than 2 feet. The tide is felt 70 miles up the St. John River, in New Brunswick, where the elevation is 14 feet above sea level; and at Montreal, 280 miles up the St. Lawrence River.

★The action of tidal currents in narrow rivers is very different from the action of tidal currents on open seacoasts. In rivers, when the water stands above the average level, the tidal current flows upstream along with the tidal wave; when the water stands below the average level, the tidal current flows downstream, opposite to the direction of the tidal wave. Since the rate of flow depends upon the difference in level, the flow is most rapid at high and low water, instead of being slack water at these times, as on open coasts. Hence the tidal current flows upstream for some time after high water has passed and the water level is falling; and the tidal current flows downstream for some time after low water is reached and the water level is rising. In broad, deep mouths of rivers, slack water does not occur at high and low water as on open coasts, nor at average level, as in narrow, shallow rivers, but at some intermediate level.

**429. Tidal bore.** In the estuaries of many rivers, broad flats of mud or sand are nearly exposed at low water. The tidal wave, when entering these rivers, often rises so rapidly that it assumes the form of a wall of water. Such a wave is called a *bore*. Tidal bores occur in some of the rivers of China, where in one case the water travels up the river at every high tide, often reaching a height of 12 feet. After the bore has passed, an after-rush often carries the water up several feet higher.

Bores have been observed on the Severn in England, on the Seine in France, on the Amazon in South America, and on a few other rivers.

★430. **Causes of the tides.** To understand the causes of the tides with all the factors involved requires a very complicated piece of mathematics, entirely unsuited to a book of this kind; but, if most of the details are omitted, it is possible for us to get at least a superficial understanding of the subject.

According to Newton's Law of Gravitation, and the Laws of Motion, the tides are due to the gravitational effects of the sun and moon on the sea, together with the effects of centrifugal force. Now let us see what these statements mean. The Law of Gravitation tells us that the sun and moon attract the earth and the water on it and tend to draw it toward them.

The attraction depends upon the mass of the bodies, and also on their distance apart. A larger body has a greater attraction: if it is twice as large, it will exert twice the attractive force; and on this basis the sun has the greater gravitational effect. But, if the body is twice as far away, it exerts *less* attraction: not one half, but one quarter; or, in other words, distance is more important than mass. For this reason, the moon, although much smaller than the sun, has more attraction for the earth, *because it is much nearer.*

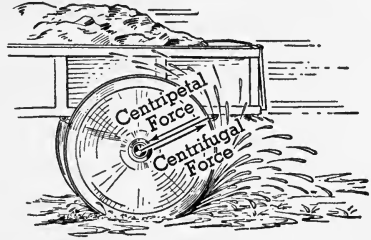

FIG. 309

When a body is revolving about a point, it has a tendency to *fly away from the point*. This is called *centrifugal force*. It is illustrated by mud flying from a wagon wheel because the centrifugal force is greater than the force which holds the mud on the rim (Fig. 309). The greater the distance from the center, the greater the centrifugal force, because the velocity is almost zero at the center of rotation and increases as we get farther away from the center. If we understand these two things, gravitational attraction and centrifugal force, we are ready to investigate the causes of tides.

Let us first summarize the principles we need to know.

1. Gravitational attraction between two bodies increases in proportion to their masses.
2. Gravitation decreases with the *square of the distance*.
3. Principle (2) is more important than (1).

4. Centrifugal force is developed on a rotating body.
5. It increases with the distance from the center of rotation.

The direct tide is simple to understand; but there is another high tide directly opposite on the other side of the earth, at the same time. To understand this indirect tide we need to understand one more point.

The moon does not revolve about the earth, as is commonly

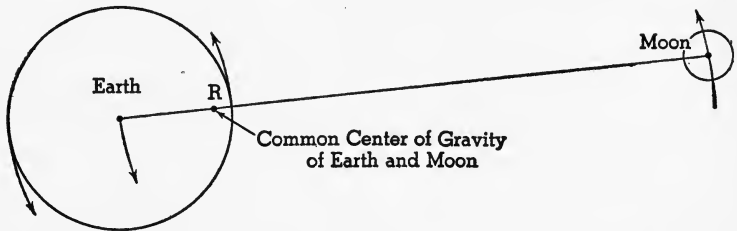

FIG. 310. The moon and the earth revolve about the axis,  $R$ .

thought, but *both earth and moon revolve about a common axis*, as if they were attached to a rigid rod (Fig. 310) just like two weights, one very large, the earth, and one small, the moon. The earth is about 80 times the mass of the moon; so the axis of Revolution, which is at the common center of gravity,  $R$ , is much nearer the

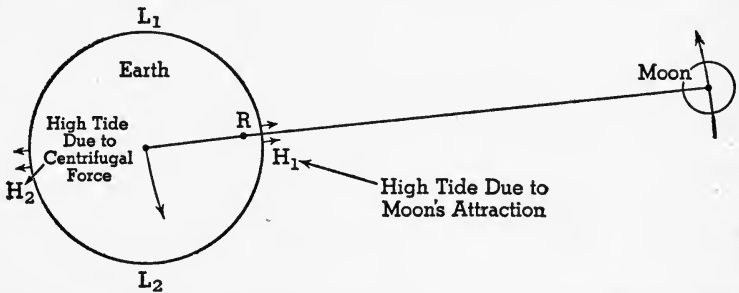

FIG. 311. High tides are developed at  $H_1$  and  $H_2$ , while there are low tides at  $L_1$  and  $L_2$ .

center of the earth than it is to the moon. In fact, the point is about 100 miles within the earth itself. This rotary movement produces centrifugal force and tends to throw the water off the earth; but, of course, the attraction of the earth itself holds on to the water:

In Fig. 311 the high tide at  $H_1$  will be due to the attraction of

the moon on the water. At this point we need not consider the centrifugal force, because  $H_1$  is very near  $R$  and the force is small.

At  $H_2$  there is another high tide, because there the moon's attraction, which would help hold the water *toward* the earth, is small because of the great distance from the moon. But the *centrifugal force is much greater*, because  $H_2$  is much farther from  $R$  than  $H_1$ .

To sum up, the high tide at  $H_1$  is due principally to the moon's attraction; and at  $H_2$  it is due principally to the centrifugal force. At  $L_1$  and  $L_2$  we have low tides, since these places are farther from the moon than  $H_1$ , but not so far as  $H_2$ .

**431. Effects of the earth's rotation.** So far, we have been assuming that the earth and the moon have no other motions, except

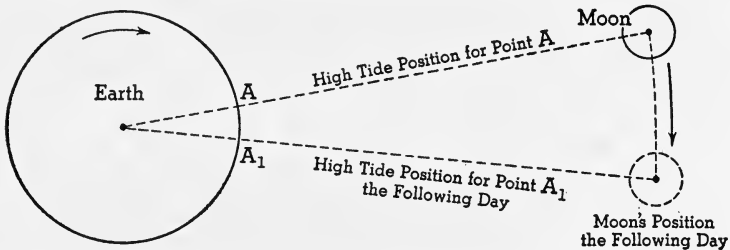

FIG. 312. Successive direct high tides are 24 hours and 52 minutes apart, because it takes 52 minutes for point  $A$  to travel to position  $A_1$ .

around their common center of gravity. If that were so, the high tides would remain at the same places. But actually the earth's rotation on its own axis has an effect on the tides.

Supposing the moon stood still, while the earth rotated. Then, as a place came directly under the moon there would be a direct high tide and twelve hours later that place would have an indirect high tide. But the moon revolves about the earth-moon center of gravity, and in the same direction as the earth rotates. In other words, the moon is moving away from a given point on its orbit, and in order to catch up, the earth will have to turn *more* than one complete circumference; and it takes just 52 minutes to accomplish that. Therefore successive direct high tides are 24 hours and 52 minutes apart (Fig. 312).

Tidal movements are interfered with by the continents, by shallow water, by strong winds, and by atmospheric pressure. This

explains in some measure why the actual local tides in so many places fail to agree with the theory.

**432. Establishment of the port.** The earth rotates rapidly on its own axis, carrying the tidal wave with it; but the moon holds it back, and this causes the tidal wave to lag. The interval of time between the passage of the moon across the meridian, which should produce high tide, and the actual time of the high tide, which comes late, is called the "establishment of the port." This has a different value for every port. At New York it is 8 hours and 13 minutes.

**433. How solar tides affect lunar tides.** The explanation of solar tides is similar to that of lunar tides. The sun's

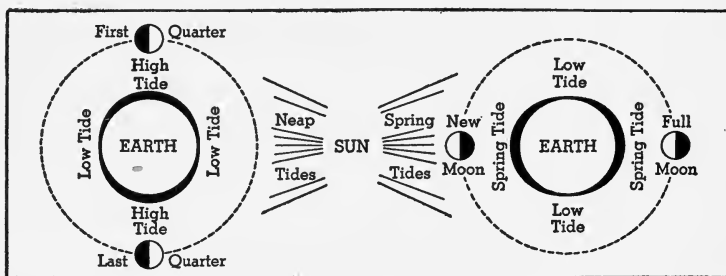

FIG. 313. Spring and Neap Tides

At spring tide, when both sun and moon act together, the high tides are higher and the low tides lower than at neap tide.

effect is about half that of the moon. When sun and moon act together, the tides are stronger; when they oppose each other, the tides are weaker (Fig. 313).

Twice a month, at times of new moon and full moon, the lunar and solar tides fall together and so produce a higher tide than usual, called *spring tide*. It must be noted that this tide has nothing whatever to do with the spring season. At first and last quarters of the moon, the solar high tide falls at lunar low tide, and solar low tide falls at lunar high tide. The effect of this is to lessen the tidal range; that is, the high tides are not so high and the low tides are not so low as usual. This condition of least range is called *neap tide* (Fig. 313).

★434. **Inequality of tides.** The two successive high tides of a given place are usually of unequal height. They are of equal height only when the moon is over the equator and as this happens on only two days of the month, two weeks apart, the two successive high tides are usually unequal. The maximum inequality of the successive high tides occurs when the moon is farthest north or south of the equator, and amounts to several feet at some places.

435. **Effects of tides.** Tides have an important effect on navigation. Ocean liners must take them into account; for in some harbors there is not enough water to float a large vessel over a bar or other obstruction at low tide, and therefore it is necessary to wait for high tide, to enter and leave the harbor.

The erosion caused by tidal currents is known as *tidal scour*. It keeps inlets in barrier beaches open, as may be seen along the shore of New Jersey, and often maintains deep waterways in bays, to the advantage of navigation. In other places the tidal currents may deposit material and hinder navigation.

Tidal currents maintain circulation and remove sewage drained into bays by neighboring cities. Vessels are aided or hindered in their movement by tidal currents and sometimes they are brought to danger on rocks and shoals, especially in fogs.

Tidal currents transport material along shore from more exposed positions, headlands, to quiet water at the heads of bays, and this tends to straighten the shore line.

436. **Ocean currents.** Every continent is washed by ocean currents, and every ocean has its distinct circulation. Currents from equatorial regions carry warm water into polar regions, and other currents carry the cold polar waters toward the equator.

While each ocean has its separate circulation, yet the separate schemes of circulation fit into the general scheme as cogwheels in a vast machine.

The Pacific Ocean, which for most purposes is considered

as one ocean, is, by reason of its circulation, divided into two distinct parts, the North Pacific and the South Pacific. The Atlantic and Indian oceans, lying, like the Pacific, on both sides of the equator, are also divided into northern and southern oceans, by reason of their distinct circulation.

**437. Systematic movement.** Ocean currents, like air currents, obey Ferrel's Law, in that they turn to the right of a straight course in the northern hemisphere, and to the left in the southern. This results in a distinct eastward drift toward the margin of the south polar ocean, and a less distinct eastward movement about the Arctic Ocean. In other oceans the northern divisions have a clockwise circulation, whereas the southern divisions have their circulation counterclockwise (Fig. 314).

The movement of the waters in all oceans is chiefly about the margins, leaving the great central areas undisturbed. In these areas of quiet water, seaweed and other floating matter accumulate, thus producing what are known as *Sargasso seas* (Fig. 317). These seas are avoided by masters of sailing vessels, who find it difficult to get out of the drift-covered waters when driven into them by storms. Columbus thought, when he came to the Sargasso Sea in the Atlantic, that he had come upon land.

**438. Cause of currents.** All winds, however fitful, brush the surface water along with them. If they constantly vary in direction, no systematic or continuous currents can result. When the same direction is held for several days, a distinct drift *with the wind* is observed.

Continued east winds over Lake Erie have at times so heaped up the water toward the west end of the lake that Niagara Falls has practically run dry, whereas a continued west wind brings an unusual volume of water over the falls. We are told, too, that strong east winds sometimes drive the waters back from one of the arms of the Red Sea and make it possible to cross this basin "dry shod."

Other minor causes may operate to produce locally cur-



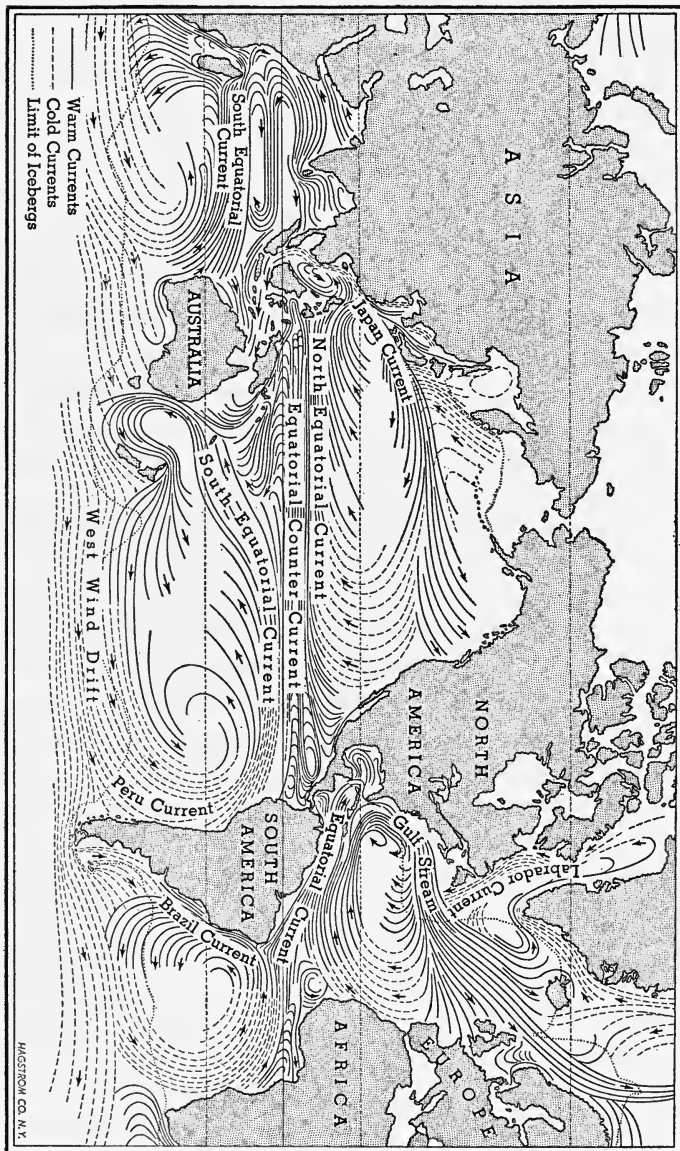

Fig. 314. Ocean Currents

rentlike movements by causing differences of level in the ocean surface. The excessive rainfall in the doldrum belt, combined with excessive evaporation in the trade-wind belts, tends to cause northward and southward movements of the surface waters; and great storms, like the Galveston storm, pile the water up against the land, to be returned as local currents. Differences of temperature produce *vertical* currents when the surface water is colder than the water below, but horizontal variations in temperature can scarcely cause perceptible motion.

**439. Ocean currents caused by the trade winds.** Since continuous wind from a given direction sets the water drifting with it, the *trade winds*, blowing, as they do, always from the same direction, would seem the logical *cause* of those world-wide movements found in all oceans, known as ocean currents.

Near the eastern sides of the oceans, where the trade winds are not well established, the currents are weak and somewhat irregular, but farther west, away from the disturbing influence of the continents, the currents both north and south of the equator are pronounced and continuous.

The current under the northeast trades is known as the *north equatorial current*, and that under the southeast trades the *south equatorial current*. These are found in the three oceans that lie athwart the equator; and between them is found an *eastward-moving* current known as the *equatorial countercurrent*, to be explained later. The north and south equatorial currents may be considered the *birthplaces* of the world-wide system of ocean circulation.

**440. Poleward currents.** The equatorial currents are barred in their westward movements by islands and continents across their paths. They are thus forced to turn poleward along the western shores of the oceans. Whether they turn northward or southward is determined by the outline of the coast.

While the currents are moving along and near the equator,

the earth's rotation has but slight deflecting influence; and it is probable that, if not interrupted by land barriers, the equatorial currents would continue their westward course around the earth.

As soon, however, as they begin to flow into other latitudes, the rotation of the earth is effective in turning them from a straight course, to the right in the northern hemisphere and to the left in the southern.

These poleward currents are *warm* currents and carry the warm water from equatorial regions into colder latitudes. At the same time they spread out, lose their velocity, and are then known as *drifts*, which move to the margins of the polar oceans, then eastward to the eastern shore of the ocean in which they have their origin.

**441. Equatorward currents.** By continued deflection these eastward moving currents, now cooled by loitering in high latitudes, are in part turned toward the equator along the western coasts of the continents. Returning thus to the trade-wind belts, in which they assume their westward direction, the circulation about the nonpolar oceans is complete. Other branches of the eastward-moving currents are, by the configuration of the land or sea bottom, made to take other courses.

The equatorward currents are *cold* or *cool* currents and bring lower temperatures toward, or even to, the equator, and so cause the *eastern* sides of all oceans in the lower latitudes to be cooler than the western sides.

**★442. Circumpolar currents.** Under the winds of the circumpolar whirl, the waters of the polar oceans move with them, *counterclockwise* in the Arctic Ocean and *clockwise* in the Antarctic. The movement of the currents about the Arctic Ocean is not so well developed, and not so strong, as that about the Antarctic, because of the numerous islands in the north that interrupt them. Branches from the circumpolar movement in the north are sent off southward into the Pacific and the Atlantic. These *cold* currents, deflected to the right, follow closely the eastern coasts of Asia and

North America, until they sink beneath the warm currents between the parallels of  $40^{\circ}$  and  $50^{\circ}$  N. Because of the unobstructed course of the Antarctic Drift, it flows eastward along the border of the Antarctic continent with a greater velocity than the Arctic Drift has. The "brave northwesterlies," that blow in this high southern latitude, are likewise responsible for the greater velocity of the currents there.

**443. Creep.** The movement of the deep polar waters toward the equator is known as *creep*. In this way the cold polar waters are carried even to the equator, and the low tempera-

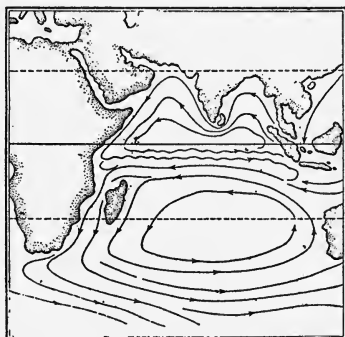

FIG. 315. Currents of the Indian Ocean in January

Note the counterclockwise current near India.

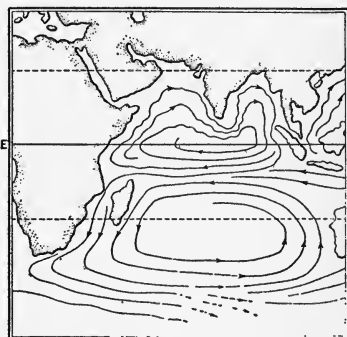

FIG. 316. Currents of the Indian Ocean in July

Note the clockwise current near India.

tures of deep equatorial seas are accounted for. We cannot observe the creep; but, as *more surface water is carried into polar regions than returns as surface currents*, the excess must be equalized by under-surface return currents.

**★444. Monsoon currents.** If any doubt existed as to the sufficiency of the winds to produce ocean currents, that doubt would be removed by a study of those currents which change their direction with the change of direction of the monsoons.

While there are monsoons at the horse latitudes, the winds there are neither of sufficient strength nor constancy to be effective in producing ocean currents. It is in the monsoon belt, over which

the heat equator migrates, that we find conditions favorable for the production of ocean currents.

★445. **Currents of the northern Indian Ocean.** About the northern Indian Ocean, when the southwest monsoon blows, the water is set drifting in a clockwise direction. As these winds weaken, the drift slackens; and soon after the northeast monsoon begins, the direction of the drift is reversed. It continues as a counterclockwise circulation while the northeast monsoon continues, changing again to the clockwise direction with the return of the southwest monsoon. These changes of direction of the ocean currents can be accounted for only by the reversal of the winds.

★446. **Equatorial countercurrents.** In the Pacific Ocean, where the heat equator lies prevailingly north of the terrestrial equator, the southeast trades, changed to southwest winds north of the equator, *set up an ocean drift to eastward.*

This is the *equatorial countercurrent*. It is fairly distinct throughout the year, though better developed during the northern summer. Its explanation is the same as that of the clockwise movement about the northern Indian Ocean during the southwest monsoon.

Because of the narrowness of the Atlantic Ocean at the equator, the countercurrent is not so well developed as in the Pacific.

447. **Currents and navigation.** Sailing vessels lay their courses to suit the winds and oceans currents, and even steamships do not scorn to take advantage of the great ocean circulation.

Sailing vessels from New York to English ports take advantage of the northeast Atlantic Drift; on their return they use the trades. Those bound from New York to Rio de Janeiro must lay their courses far to eastward of the eastern cape of South America, lest the equatorial currents carry them northward again while in the doldrums, where winds are apt to fail.

Ships sailing from Atlantic ports for Australia sail eastward around the Cape of Good Hope, to take advantage of the Antarctic Drift, while those returning also sail eastward past Cape Horn, to have the advantage of the same drift.

Vessels bound from Honolulu to San Francisco sail north-

ward beyond the trades and equatorial current, then east; returning, they take a more southerly route.

**448. Currents and life.** The distribution of many marine forms is determined by the temperature of the water, which in turn is in part determined by ocean currents. Corals serve well to illustrate. The waters of the Galápagos Islands, west of South America, are too cold for corals, although these islands lie under the equator. The Peruvian Current, bringing water from the Antarctic regions, makes these waters cold. Contrasted with these islands are the Bermudas, in the Atlantic, in latitude about  $35^{\circ}$  N, which are chiefly coral rock and are bordered by reefs of living coral. The warm waters are brought to these islands by the Gulf Stream.

The seeds of many plants are distributed by means of ocean currents, and insects and the smaller animals are carried upon drifting material in these currents.

**449. Currents and climate.** The *direct* climatic influence of ocean currents is confined to the ocean and immediately bordering lands. Indirectly their influence may be felt hundreds of miles inland. This is markedly true of lands lying to leeward of currents that are abnormally cold or warm.

*The North Atlantic Drift.* The most pronounced and far-reaching of all ocean currents, in its climatic influence, is perhaps the **Gulf Stream**. The winds from over this broad sheet of warm water not only bring abundant rainfall to the British Isles and Norway, but so temper the cold of these high latitudes as to make them comparable in temperature to our own eastern coasts,  $20^{\circ}$  farther south.

*The North Pacific Drift.* The continuation of the Japan Current tempers the climate of Alaska and British Columbia in like fashion.

These great drifts, in both oceans, send branches southward along the western coasts of the continents; and when they reach the latitude of northern Mexico and Africa, their effect is to *temper the heat of these coasts*.

The cold currents that follow closely the eastern coasts of North America and Asia, being to leeward of those continents, do not affect the climate so far inland. However, the bleakness of Labrador and Kamchatka is in some degree traceable to these currents.

In the southern hemisphere the *western* coasts are *cooled* and the *eastern* coasts are *warmed* by the ocean currents, but their influence is less pronounced than in the northern hemisphere.

**450. Currents and harbors.** The harbor of Hammerfest, at the north of Norway, and well within the Arctic Circle, is about as free from ice as that of Boston, 30° farther south. In the one case, we see the effect of the warm Gulf Stream; in the other, of the cold Labrador Current.

In the Pacific Ocean, the barrier of the Aleutian Islands, together with the narrowness of Bering Strait, prevents the North Pacific Drift from entering the Arctic Ocean. As a result, the bays on the north coast of Alaska, in the same latitude as Hammerfest, are practically closed by ice throughout the year.

The Russo-Japanese War had for one of its objects the securing for Russia of the open harbor of Port Arthur. The harbor of Vladivostock, Russia's chief port on the Pacific, in about the latitude of New York, is for a long time every year closed by ice, owing to the cold current coming down through Bering Strait.

**451. The Gulf Stream.** This greatest and most important of all ocean currents derives its name from the Gulf of Mexico, from which it issues. It is, in fact, a continuation of the combined equatorial currents.

The North Equatorial Current in the Atlantic is turned, by the land masses in its path, wholly into the northern division of this ocean. Much of its waters passes among the islands of the West Indian group, while the remainder passes to the eastward.

The eastern cape of South America is so situated that it

divides the South Equatorial Current in two; part of it turns southwest along the coast of Brazil, as the Brazilian Current, while the other part enters the Gulf of Mexico between the West Indies and the mainland of South America. This water issues through the Strait of Florida as the *Gulf Stream*. It is truly a *stream*, flowing between banks of water. At that point it is deep and narrow, scouring the bottom of

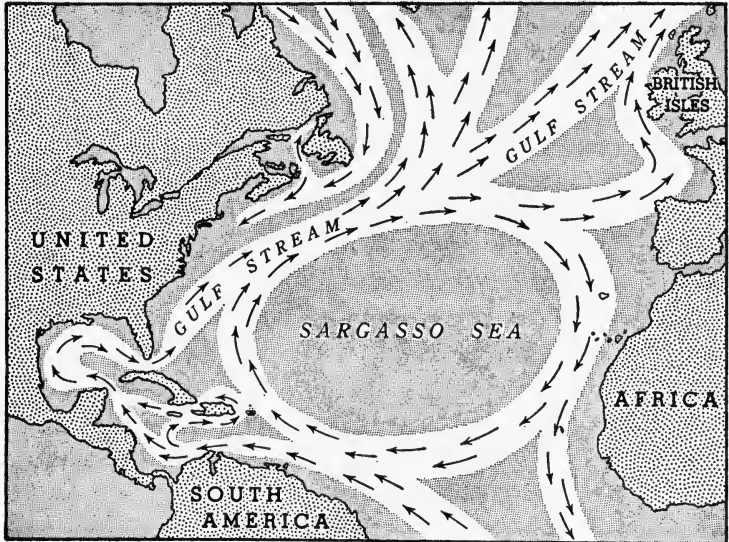

FIG. 317. The Gulf Stream

the strait, and it flows with a velocity greater than that of the lower Mississippi River.

Joined by the waters that come through the West Indian group of islands and the waters which pass outside, the Gulf Stream is greatly increased in volume. It passes parallel to the Carolina coasts and near enough to send off return eddies, which build the Carolina capes. Spreading and decreasing in velocity, the Gulf Stream becomes the North Atlantic Drift.

The frequent and dense fogs off Newfoundland are produced by warm winds from the North Atlantic Drift blow-



ing over the cold Labrador Current. The line of meeting of the cold and warm water is known as the *cold wall*.

### Completion Summary

Wave action undercuts ——— and causes the collapse ———. This ——— sea cliff, and the ——— forms a beach. Vertical joints ——— stacks, and ——— sea caves. The land in this way is cut down below ———, and roughly smoothed off into a ———. The fine material is dragged out ——— and wave-built terrace. The bottom is worked over by waves and piled up into ———. Behind the ——— lagoon.

★This lagoon is gradually ——— by ——— from the land, by the growth of ——— and by the action of the waves on the barrier beach.

There are ——— high tides every day; at ——— 12 hours and 26 minutes. Tidal range varies, on the shore, from a few ——— up to ——— feet. Flood tide is the ——— incoming ———; ebb ———. Slack water ———. The currents become ——— in narrow channels. The tidal current entering rivers with ——— becomes a wall of water, called a ———.

★Tides are caused principally by the ——— together with ———. The direct tide is due chiefly to ——— moon. The indirect tide,  $180^\circ$  ———, is caused chiefly by ———, which is a greater force than ——— moon. For, since the water there is farther away from the center of rotation, the ——— is greater than it is on the side near the moon; and at the same time the moon's ——— on the water is less ——— than ———.

If the earth did not rotate, or the moon did not ———, high tides would come at the ——— time every day. The ——— of the moon in the same ——— earth causes the tides to be ——— later each day.

The sun ——— tides, but ——— moon. When, however, both sun and moon ——— straight line with ———, the

high tide is ——— and the low tide is ———. It is then called ——— tide. This happens at times of ——— and ——— moon. At ——— and ——— of the moon, the tidal range ———. These are called neap tides.

Ocean currents are caused by ———, and like ———, they are deflected in accordance with ——— Law. The trade winds, being continuous, ——— currents.

The north equatorial current starts in the warm ——— seas, moving ———, is turned ——— by ———, then east by ———, and finally ——— by the ———. This circulation has ——— direction.

Cold polar water seems to *creep* toward ———, along ———.

★Wherever there are strong monsoon winds, currents are ———.

The climate of many coasts ——— by ———. The Gulf Stream flows ——— near the ——— coast of the United States, then turns ——— and bathes the shores of ———, making the climate of ——— Europe distinctly ———.

### *Exercises*

1. Describe wave motion in water.
2. What produces waves?
3. How high are the largest waves?
4. What is the groundswell?
5. What are breakers? Where do the waves break?
6. What causes the undertow?
7. What is the relation of the undertow to a longshore current?
8. Describe the work of wave erosion.
9. Describe the formation of a sea cliff.
10. How is a beach formed?
11. Why are stacks not always formed by wave erosion?
12. Describe the formation of a sea cave.
13. Why do the waves cut like a horizontal saw?
14. What is a wave-cut bench?
15. What is a wave-built terrace?

16. How is a barrier beach formed?
  17. What is a spit? Why is it often curved?
  18. How is a lagoon formed? What finally happens to it?
  19. What is the time interval between tides?
  20. If it is high tide at 3.10 A.M. today, when will the next high tide occur today? tomorrow?
  21. Why is the tidal range small at some places and great at others? Where is the greatest tidal range in the United States?
  22. What is flood tide? ebb tide? slack water?
  23. What is a tidal race?
  24. How far up a river does the tide extend?
  25. What is a tidal bore?
  26. How do the sun and moon together affect the tides?
  27. What is spring tide?
  28. What is neap tide?
  29. How would an observant person, living at the seashore, connect the rise and fall of the tide with the moon?
  30. How does the tide affect navigation?
  31. When do we get the lowest water, at spring or at neap tide?
- Explain.
32. What is tidal scour?
  33. What is the effect of tidal currents on the shore?
  34. What effect has the earth's rotation on ocean currents?
  35. What is a Sargasso sea?
  36. What is the cause of ocean currents?
  37. What causes the north and south equatorial currents?
  38. Why do the equatorial currents turn toward the poles?
  39. Explain how the earth's rotation affects the equatorial currents.
  40. Describe in detail the course of an ocean current.
  41. Why are the eastern sides of the oceans, in low latitudes, cooler than the western?
  42. What is *creep*?
  43. How do currents affect marine life?
  44. What effect has the Gulf Stream on the western coasts of Europe?
  45. What effect has the Japan Current on our western coast?
  46. Show by example the effect of currents on harbors.
  47. What is the cause of Newfoundland fogs?

**★Optional Exercises**

48. How can a tidal current flow upstream, after high water?
49. Why has the moon greater gravitational effect on the earth than the sun has?
50. What is centrifugal force? On what part of a rotating body is it greatest?
51. Explain how there can be two high tides on the earth at the same time.
52. Is there any tidal effect on the rock portion of the earth? Discuss.
53. Why do we not have high tides at exact intervals of 12 hours?
54. Explain by diagram spring tide and neap tide.
55. Show by example the effect of monsoon winds on an ocean current.
56. What is the cause of the equatorial countercurrent?
57. What is meant by *establishment of the port*?

## CHAPTER XXXIII

### SHORE LINES AND HARBORS

**452. Kinds of shore lines.** An examination of the shores of the continents reveals two kinds of shore lines: *regular* and *irregular*. These are represented in Fig. 318, showing part of the coast of Alaska, and Fig. 320, showing part of

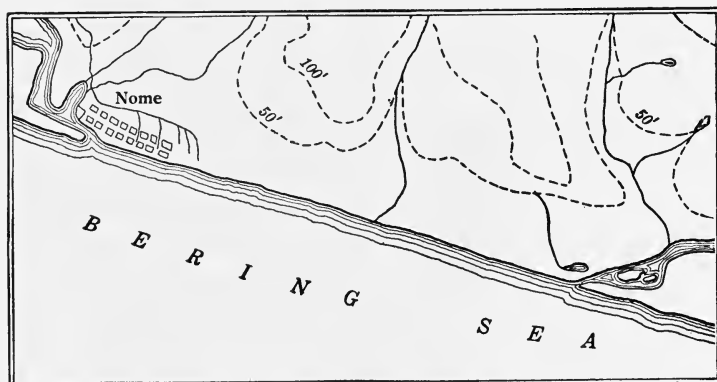

FIG. 318. A Regular Shore Line Due to Recent Emergence of the Land, at Nome, Alaska

the coast of Maine. These two shore lines have a different origin, and we shall now try to study the features of each kind of shore line, and how it is developed.

**453. Emerging continental shelf.** The continental shelf, as we have seen, is composed of loose sediments, for the most part, which are almost horizontal and quite flat. When it is uplifted slowly, it forms a coastal plain and the shore line will be quite regular (Fig. 318).

The water is very shallow for quite a distance from shore, and waves churn up the bottom and pile some of the loose material at the line of breakers. This builds up higher and

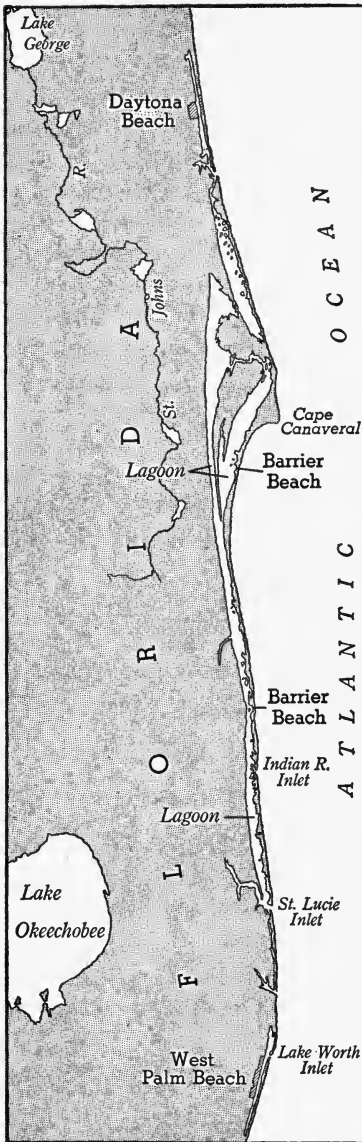
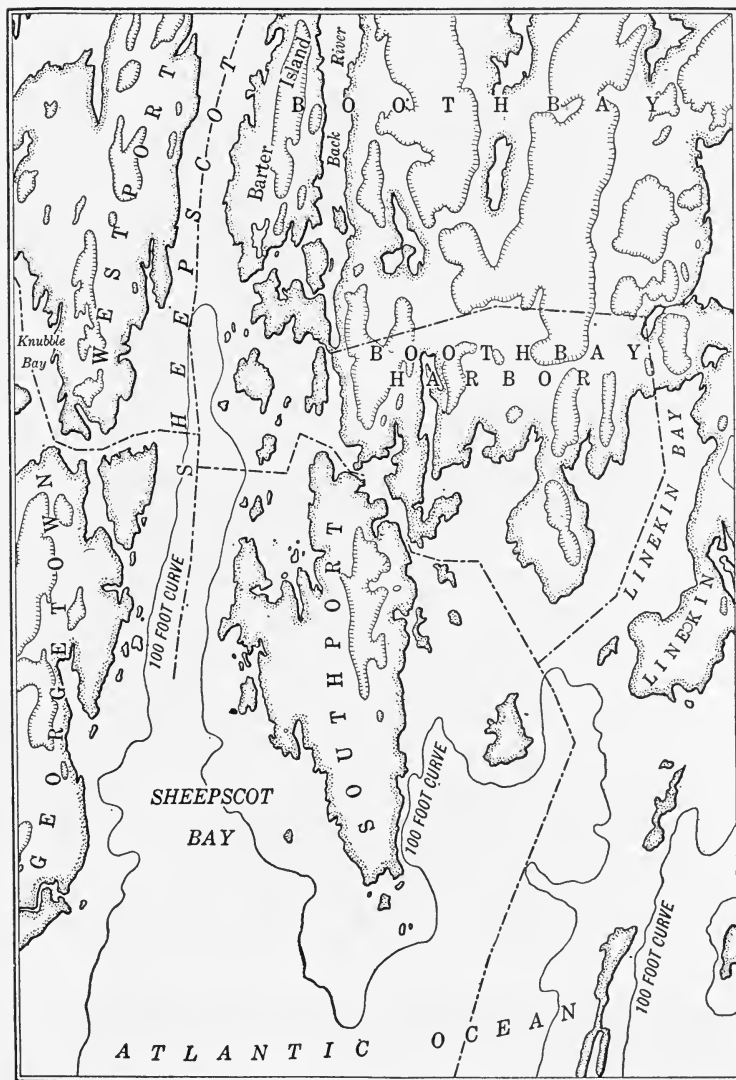

FIG. 319. An Emerging Continental Shelf, with Barrier Beaches Parallel to the Shore

higher, especially in stormy weather, until it is above sea level. It finally takes the form of a long, sandy island parallel to the shore, called an *off-shore bar* or *barrier beach*. The body of quiet water between the bar and the shore is called a lagoon (Fig. 307). The lagoon is usually about a mile across; but occasionally it may be 10 miles or more if the continental shelf slopes very gently. It is seldom more than 20 feet deep. The shore line, which *started* very regular, is now somewhat *irregular*.

Soon the waves have done all they could to the bottom outside of the bar, and they are free to break against the bar itself. They cut down the seaward side of the bar, carrying some of it out, and, during storms, hurl some of it up, over the bar into the lagoon beyond. By this process the bar is eroded and gradually moved toward the shore, filling in the lagoon. At the same time streams from the land carry their deposits into the lagoon, and help fill it up. Vegetation begins to encroach from the landward side, converting the lagoon into a *tidal*



*Boothbay topographic sheet, U. S. G. S.*

FIG. 320. The Irregular Coast of Maine

*marsh*. Finally the waves remove the bar and the sediments in the lagoon entirely, and the shore is once more regular.

The east coast of the United States from New York to Florida has recently emerged and therefore is faced by a series of barrier beaches. Atlantic City and Miami Beach are situated there (Fig. 319). The lagoon at Miami is called Biscayne Bay.

**454. The submerged coast.** When a coast is submerged, it is very irregular, because the sea enters into all the river mouths and fills in the depressions of the river valleys. This produces long narrow bays called *estuaries*, long narrow peninsulas and headlands, and numerous islands near shore (Fig. 320).

The projecting ends of the peninsulas and the islands are first attacked by waves, giving us wave-cut cliffs with long blocks hidden in the deep water. Caves and stacks may develop later, and then the blocks are broken up to form the beach. Loose material is carried into the quieter water of the bays or estuaries and deposited right across the mouth as *spits*. Such a spit is Sandy Hook at the entrance to New York Harbor. As the spit increases in length, it closes the bay, sometimes entirely, forming a *bay bar* (Fig. 321). The tidal current usually maintains an opening in the bar (Fig. 322).

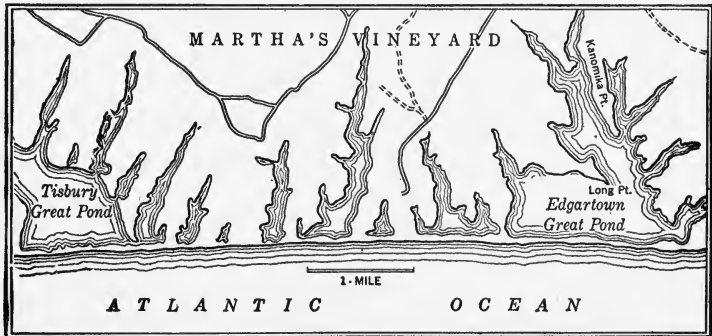

FIG. 321. Bay-Mouth Bars, Martha's Vineyard, Massachusetts

Behind the bar a body of sheltered water, a lagoon, forms. This is filled by sediments from streams, while the bay bars are extended between islands to form a barrier beach all



along the coast, giving it a more regular shore line. The lagoons develop into marshes and are gradually filled up. The indentations of the shore have now been eliminated, and the waves continue their work on the more or less straight line of cliffs (Fig. 323). If there is more than one kind of rock on the shore, the weaker rock will be worn more rapidly and the

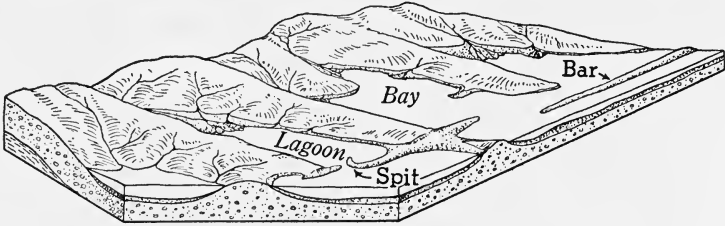

FIG. 322. Drowned Shore, Showing Spits, Bay Bars and Lagoons

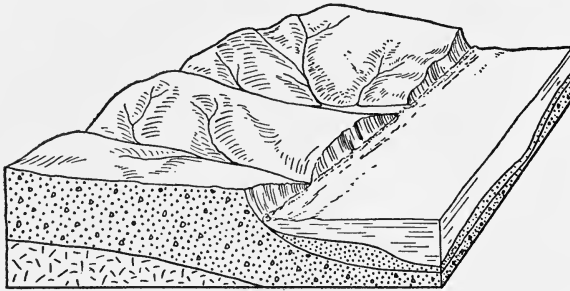

FIG. 323. Drowned Shore in Maturity

harder one will still form promontories, so that the development of a regular shore line will be indefinitely postponed.

Irregular shores, particularly those due to recent drowning, have good harbors because the water is deep and the surrounding hills form a haven.

★455. **Fault-plane shores.** In many parts of the world a fault in the bedrock is the cause of the submergence. The seaward side of the fault is submerged, and the landward side forms a long row of rocky cliffs that make a very regular shore line. Harbors on such a coast are likely to be small, shallow, and far apart. Such shores make commerce even more difficult than the offshore bars do, be-

cause there is the added difficulty of moving freight up and down the face of the cliffs.

Figure 324 is a block diagram of such a coast. The fault plane, or the plane of the break, is marked 1, 2, 3, 4. The unshaded portion is water, standing at the level 5, 6, 7, 8, and submerging one

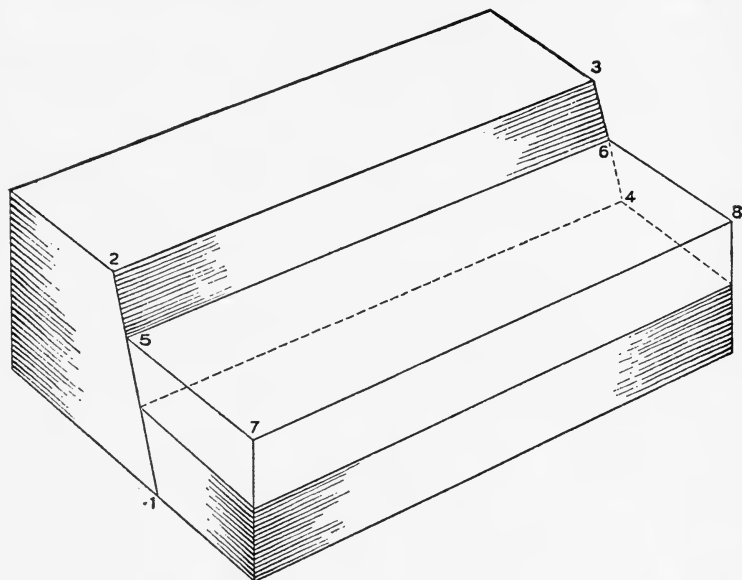

FIG. 324. Diagram of a Fault Plane Shore

*After Cotton*

side of the fault. The surface of the fault plane, marked 2, 3, 6, 5, forms the row of cliffs above water.

Beaches and continental shelves on such fault-plane coasts are rare, except on those that are approaching old age, but they will be built, in time, as the cliffs are weathered and eroded and as sediment brought in by streams accumulates. Drowned valleys are absent. Fault-plane shores occur in New Zealand, on the shores of the Red Sea, and on the west coast of Africa.

**456. Mountainous shores.** Young, folded mountains, parallel to and near a shore, would form a very regular shore line if they had emerged enough to raise the passes well above the sea. The western coast of the United States has the Coast Range quite near the shore, and the shore line re-

sembles the smooth curves of the offshore bars much more than it does the irregular coast of Maine. It is also like a regular shore in the scarcity of good harbors. Figure 325 shows about 125 miles of the California coast, without an important harbor. There are but two large rivers that have eroded channels through the mountains and formed important harbors on the western coast of the United States. They are the Columbia and the Sacramento. The scarcity of good harbors is a characteristic of many mountainous coasts. When, however, the mountains are submerged so that the passes are drowned, the valleys will also be drowned, forming an irregular shore line like that shown in Fig. 326.

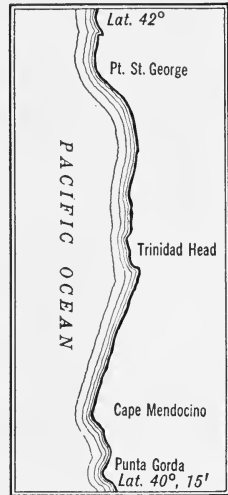

FIG. 325. Shore Line in California

★457. **Fiord shore lines.** In cold regions where ice is of enormous thickness, valley glaciers sometimes gouge out the river valleys far below sea level.

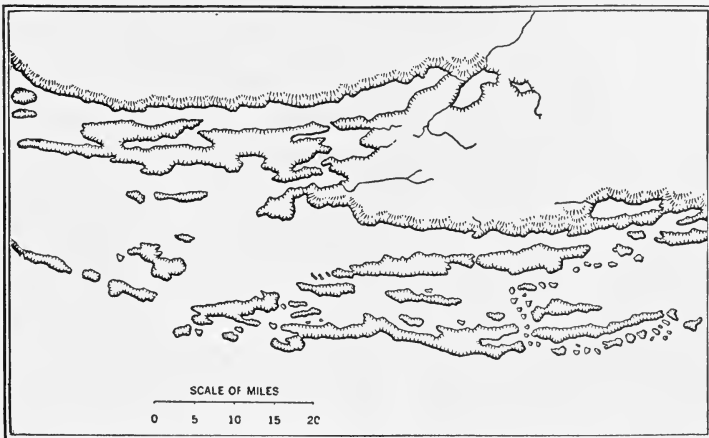

FIG. 326. Submerged Mountain Ranges

The east coast of the Adriatic south of Istria. The ranges run parallel with the shore.

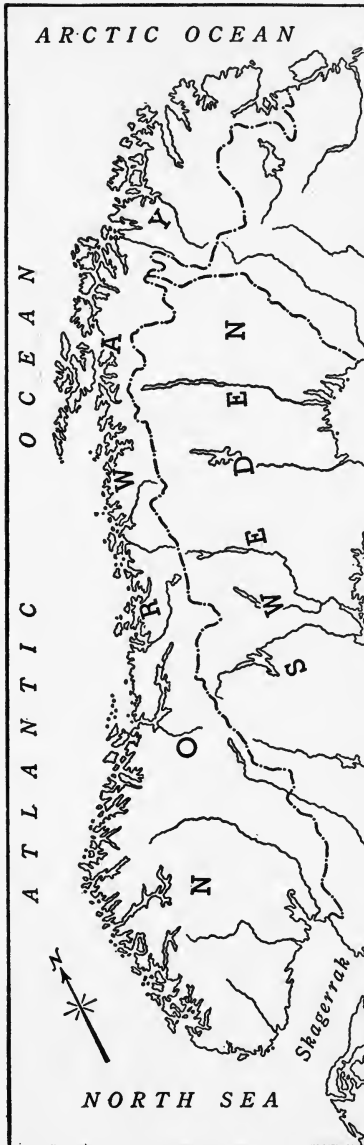

FIG. 327. The irregular coast of Norway has innumerable fiords.

When the ice recedes, the lower ends of these troughs will be submerged by the sea. These are *fiords*. They are long, narrow, branching bays of great depth, with U-shaped cross section and steep sides. The lower Hudson River is a fiord without steep sides. The coasts of Norway and Alaska are full of fiords, which make a very irregular coast line (Fig. 327).

**458. Coral reefs.** Southern Florida, the Hawaiian Islands, and the shores of all oceans of the torrid zone, except the eastern shores of the Atlantic and the Pacific, are fringed with jagged coral reefs.

The *reef-building coral* is a small animal living in colonies attached to the ocean floor. It requires clear, warm, salt-water currents to bring it food, and it requires light, which it cannot get much below a depth of 120 feet. It extracts limestone from sea water and deposits it in the lower part of its body. By the growth and decay of countless corals, the rocky base may be built up nearly to the surface of the sea. The waves break off branches of the coral

and grind them to coral sand, which finally consolidates to a granular limestone. The waves and the wind may build up a low reef, not more than 20 feet above the level of the sea.

Where the reef is close to the shore, as along eastern equatorial Africa, Brazil, Cuba, and the Hawaiian Islands, it is called a *fringing reef*. The outer border, better supplied

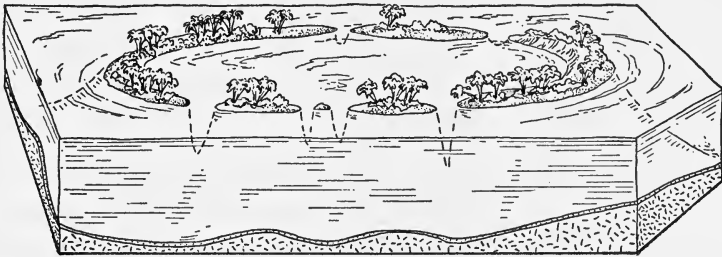

FIG. 328. An Atoll

with food, grows more rapidly than the inner. Within, the corals die and the rock is dissolved, until a lagoon may develop inside the *barrier reef*, as it is now called. The Great Barrier Reef of the northeast coast of Australia is about 1,200 miles long.

An *atoll*, or ring of coral around a central lagoon, may be formed where the coral has grown on the top of a shoal that came to within 120 feet of the surface (Fig. 328). Or, according to Darwin's theory, the atoll is a coral reef around a *sunken* island, as for example, a volcano. The growth of the coral equaled the rate of sinking. When the rate of sinking, or rise of water, exceeds the rate of growth, the coral are drowned. The Chagos Islands in the Indian Ocean are the unsubmerged portions of a very extensive coral region.

Coral islands are naturally very low, though some few show that they have been elevated. Plant life may be abundant, though of few varieties. The coconut palm furnishes food, clothing, and utensils to the unambitious natives.

**459. The submerged Atlantic Coastal Plain.** The Atlantic coast of the United States shows features of uplift as

well as submergence. It was first uplifted, giving us the Coastal Plain with the long barrier beach, extending all along the coast and around Florida; and then recently it has been partly submerged and this has developed irregularity in the shore line by forming deep bays and blocking them up with bay bars (Fig. 329).

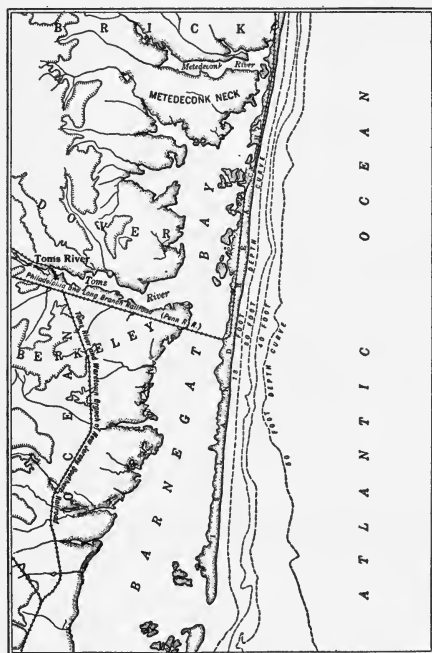

*Barnegat sheet, U.S.G.S. and coast chart (reduced)*

FIG. 329. Part of the Submerged Atlantic Coastal Plain

The shore is low and marshy from New York south, but the land rises gently to the fall line. The strata beneath the soil are the same as those of the continental shelf and contain many marine fossils, which prove the former submergence of the region.

Although the shore is irregular, it has very few good harbors, because of the offshore bars and shallow lagoons which have developed.

The major irregularities of the coast, such as New York Bay, Delaware Bay, Chesapeake Bay, and several others, are among the most important harbors of eastern United States (Fig. 330). In these protected bays we find the great cities of Boston, New York, Philadelphia, Baltimore, Norfolk, and Charleston.

The drowned valleys of the Atlantic coast were eroded, as a rule, in the unconsolidated sediments of the uplifted coastal plain, which accounts for their V-shaped cross section and the general narrowing of the submerged portion as we

follow them inland. The drowned valley of the Hudson River, above the Harlem, was eroded out of bedrock by stream and glacier.

**460. The Maine coast.** Figure 320 shows a part of the Maine coast. There are many offshore islands and rocky promontories, and many *estuaries*. Estuaries, as you recall, are wide-mouthed, drowned rivers and therefore subject to tides. Ordinary rivers have no tides.

The islands are rocky, but there is much good farm land. Beaches are few, showing that wave erosion has not gone far, but harbors are numerous. There are many lighthouses to warn shipping of the numerous rocky headlands and submerged rocks, but wrecks have been comparatively few, because of the numerous harbors.

**461. What is a harbor?** The terms *haven*, *harbor*, and *port* are each defined as a *sheltered recess in the shore line*. It is true that each of the three requires safety for the vessels, but the harbor is more than a haven; it requires means for loading and unloading vessels and for landing passengers.



FIG. 330. Harbors of the Submerged Atlantic Coastal Plain

A port is really a gateway or entrance and is defined, in law, as a place where persons and merchandise may legally enter or leave a country, i.e., where customs officials are stationed, to see that the laws of the nation concerning such entry or departure are carried out. In this sense, a port may be far from any body of water.

The location of a harbor is necessarily limited to places where it is convenient to transfer passengers and merchandise from vessels to land or vice versa.

**462. Historic importance of harbors.** There has been a close relation between harbors, trade, and the spread of civilization, ever since the Phoenicians carried their alphabet and the products of Egyptian and Asiatic civilizations from Tyre and Sidon to Greece, Carthage, and the western Mediterranean world. Rome was situated near the most convenient harbor on the borderland between Greek and Etruscan civilizations. Although on the surface the Punic wars, between Rome and Carthage, had other causes, the real underlying cause was the trade rivalry between two nations, each of which had a good harbor. After Carthage was destroyed, Rome became mistress of the Mediterranean world.

During the Middle Ages and the Renaissance the products of the civilizations of the East and West were distributed largely by those cities that had good harbors, the Italian cities, Venice and Genoa, and the German cities, Hamburg and Bremen.

In modern times the United States, England, Holland, and Germany owe no small part of their rapid advance in power and wealth to their numerous harbors.

**463. What makes a good harbor?** A short description of the landing of passengers or freight from ocean vessels in a good harbor and a poor one will make it clear why nations with good harbors monopolize the trade of the world, why people prefer to land at those ports, and why its merchants can undersell their rivals in other countries.



When a large vessel approaches Cherbourg, France, a rather poor harbor, it must anchor miles offshore and transfer its passengers and freight to small boats, which then steam into the harbor and tie up against the wharf. Passengers can then walk down gangplanks and freight can be transferred by derricks or other mechanical devices. There are harbors even more open than Cherbourg, and if the weather is stormy, the transfer at sea is dangerous and very slow, because the lighter bobs up and down, and it becomes difficult to step into it. It is not unusual for a person to fall into the water in the process.

Contrast this with landing at New York, Southampton, London, Liverpool, or Hamburg, which are fine harbors. In the first place, a storm has practically no effect on the landing, because the docks are situated in places protected from the winds, and each dock is covered so that one is practically in a building. Gangplanks are lowered, and passengers walk onto the dock. Freight is handled by derricks and traveling cranes, which sometimes load material directly into waiting cars on tracks parallel to the shore (Fig. 331).

It does not cost much to ship goods through a good harbor, because it is not transferred and handled several times, and therefore the merchants of that city and those shipping that way can undersell others.

#### CHARACTERISTICS OF A GOOD HARBOR

1. Protected from wind and wave
2. Sufficient anchorage without rock bottom
3. Deep water at entrance and alongside docks
4. Docks must be long enough.
5. There must be numerous docks.
6. Adequate facilities: elevators for grain; pumps for tankers; clamshell buckets for coal; derricks and traveling cranes for heavy freight
7. Open throughout the year. No ice in winter
8. Access to a rich hinterland

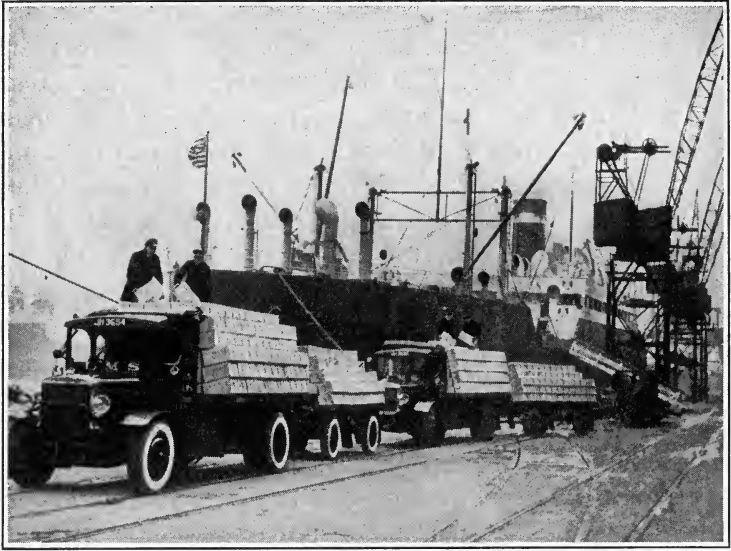

Acme

FIG. 331. London Dock, Showing Facilities for Handling Freight and Passengers

The importance of (7) became one of the causes of the Russo-Japanese War. The Russians had no ice-free harbor, and their desire to acquire one brought them into conflict with Japan. During the war important units of the Russian Navy were icebound in the harbor of Vladivostock, which perhaps brought about the defeat of the rest of the navy at the hands of the Japanese fleet.

**464. New York Harbor.** "The City of New York has become the metropolis of North America because of the natural advantages of its geographical location, rather than because of the acumen of its business men."

Let us see whether the facts justify this statement (Fig. 332).

New York is situated at a corner in the shore line. The shores of Long Island have an easterly trend, as indicated by Coney Island and Rockaway Beach; and the adjacent shore of New Jersey has a southerly trend, as indicated by

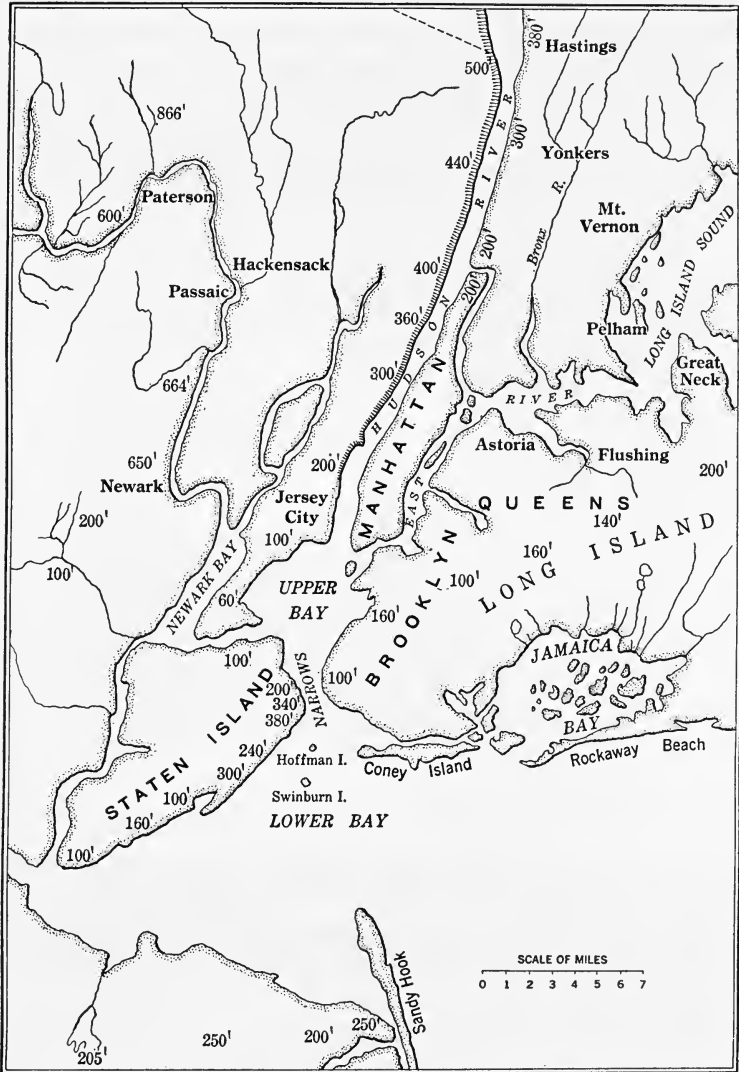

FIG. 332. New York Harbor

Sandy Hook. The harbor, which comprises the Upper Bay, the East River, and the lower Hudson River, is practically surrounded by land more than 100 feet high on all points of

the compass, and is therefore protected from wind and wave. The water is deep enough to accommodate the largest ocean liners, right alongside the docks, although dredging is constantly carried on in the Narrows. There are scores of docks longer than the biggest vessels.

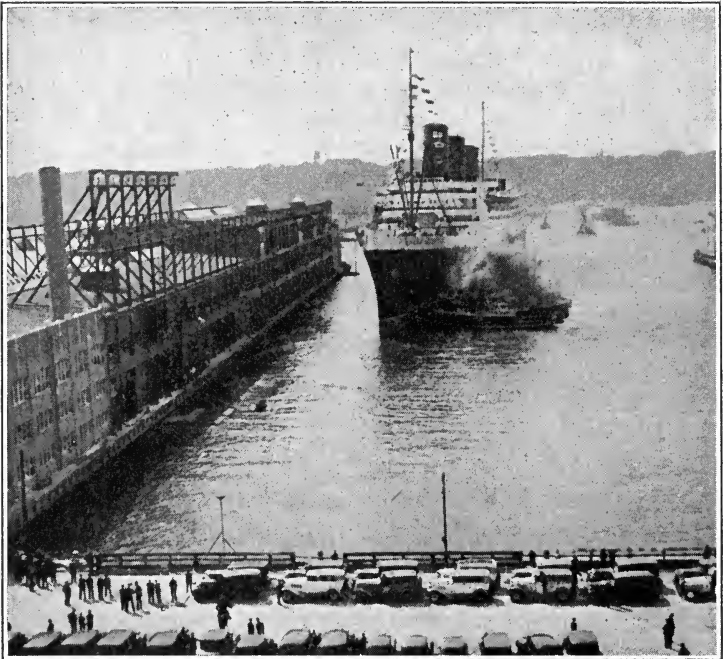

FIG. 333. The largest transatlantic vessels can be accommodated in New York Harbor. *Acme*

The facilities at the docks are unexampled; mechanical devices of all kinds are found, and storage facilities are near at hand (Fig. 333).

The harbor is never frozen over.

Add to all that its nearness and accessibility to eastern and central United States via the Hudson River, the Erie Canal, the Great Lakes, and the innumerable railroads, and it is easy to understand why New York Harbor is the best

in the world, and why it has become the center of the trade of the United States and the wealthiest and most populous city of the world.

**465. Submerged valley harbors.** The harbors of New York, Philadelphia, San Francisco, Seattle, Montreal, Quebec, Liverpool, Bristol, London, Shanghai, Hamburg, and scores more of the important harbors of the world belong to this class. The submerged valleys were formed by stream erosion. Even the great harbor of San Francisco, sometimes classed as a mountain-range harbor, is really the submerged valley of the Sacramento-San Joaquin River, which reaches the ocean through the "Golden Gate" that the river cut through the Coast Range.

*Advantages.* As a rule these harbors are *large, deep, and well protected*. Many of them have connecting waterways that extend far inland. For example, the St. Lawrence connects the harbors of Quebec and Montreal with the Great Lakes and more than 1,500 miles of navigable water. Hamburg receives freight from the Austrian frontier, and Shanghai from far across China. The *large volume of water that flows into and out of some of these harbors at each change of tide keeps the entrance to the harbor open*.

*Disadvantages.* Some drowned valley harbors have to contend with a *shallow entrance*, as at Liverpool, where a bar across the mouth of the Mersey prevents the passage of large vessels except at high tide. Some of them have a *crooked entrance*, as was formerly the case with New York Harbor. The modern ocean liner, 1,000 or more feet long, could not steer through the crooked entrance; so the old Ambrose Channel, which was only 16 feet deep at low tide, had to be widened, deepened, and straightened.

This was done at a cost of about \$6,000,000, and we now have a channel 2,000 feet wide, 40 feet deep at low tide, and seven miles long, with but one curve.

*Some submerged valley harbors have excessively high tides.* At Liverpool they formerly had considerable difficulty in

loading and unloading vessels that were raised or lowered 20 feet between tides. The difficulty was partially overcome by building an immense floating raft or "landing stage" with drawbridgelike approaches, similar to the hinged approaches that enable us to drive motor cars onto ferry boats.

**466. Crater harbors.** The harbor of Ischia, in the Bay of Naples, occupies the crater of a dormant volcano. Such harbors are usually well protected, but they frequently have a rocky bottom, which causes the loss of many anchors. The island of St. Paul, near Ischia, also has a crater harbor, and so has the island of St. Thomas in the West Indies. The depression is due to the shrinkage of the cooling lava that formed the crater.

**467. Delta harbors.** Among the important delta harbors are those at Pará, in the mouths of the Amazon; New Orleans, on the Mississippi; Calcutta, on the Ganges; and those on the Yellow River of China. They have the advantage of a large area of navigable water in the distributaries and of long, connecting inland waterways, but are subject to two disadvantages: (1) the shifting of the principal mouth, and (2) the formation of bars at the mouths of the distributaries. The latter was overcome, in the Mississippi delta, by building *jetties*, which narrowed the channel, and so caused the river to scour out the sediment between them and to carry the river's load out into deeper water. In time a bar across the entrance will be formed in this deeper water, and then the jetties will have to be lengthened again.

**468. Fiord harbors.** The water in fiords is usually very deep, close to shore, because of the U-shaped cross section. This enables ships to lie close to shore. These harbors are well protected and often have a wide, deep, and fairly straight entrance.

Their high, steep sides tend to make loading and unloading vessels difficult and to make the harbor inaccessible. Mountains sometimes surround fiords, increasing the difficulty of access. Few fiord harbors are important.

This is partly because of the disadvantages mentioned and partly because the demands of commerce are not great in these high latitudes. The harbors at Oslo and Bergen, Norway, are the most important of the kind, since they have the advantages, but not the usual disadvantages, of fiord harbors.

**469. Lagoon harbors.** Some lagoon harbors are located behind barrier beaches, others behind sand spits, and still others behind coral reefs. In each case the harbor is well protected from all ordinary storm waves but not from landward storm winds. The entrance to lagoon harbors is sometimes shallow, narrow, crooked, and dangerous, particularly when the barrier is a coral reef. Harbors behind sand reefs are usually very shallow, and, if the area of the harbor is large, may have strong tidal currents through the inlet. Some inlets to harbors behind such barriers are often being filled by sediments, while others are being opened. It is believed that there was an inlet through Sandy Hook, near Atlantic Highlands, in Revolutionary times.

Jamaica Bay (Fig. 332) is a sand-spit harbor, as is also that at Erie, Pennsylvania, on Lake Erie. The harbor at Atlantic City, New Jersey, is enclosed by offshore bars.

Biscayne Bay, at Miami, Florida, is an example of a coral barrier reef harbor. That of Hamilton, Bermuda, is an atoll harbor. Pearl Harbor, Hawaii, and the island of Guam are the most important coral-reef harbors belonging to the United States.

**470. Island harbors.** Many harbors are protected from wind and wave by islands. The harbor of Vancouver is behind a large island that protects it from the prevailing northwest wind.

The harbor of Callao, Peru, is behind an offshore island. The latitude of Callao is  $15^{\circ}$  south, and therefore the region is subject to the southeast trades most of the year and to the northwest hooked trades for the remaining months.

Many of the piers of Boston Harbor lie along the sub-

merged valleys of the Charles and the Mystic rivers, but a larger area is protected by an island of glacial origin.

**471. Artificial harbors.** Harbors have been built at both ends of the Panama Canal and on the Pacific side of the Isthmus of Tehuantepec. A well-protected harbor has been devised at La Plata, near Buenos Aires, by building great breakwaters in the open roadstead of the Plata River. The naval harbor at Dover, England, is one of the best artificial harbors in the world. Here, great concrete breakwaters enclose a deep area of about a square mile. The harbor of Hilo, Hawaii, has a breakwater two miles long; and one of about the same length at San Pedro, California, makes a harbor for Los Angeles. Breakwaters have also been built at Naples, Italy, and at Haifa, in Palestine.

### *Completion Summary*

When \_\_\_\_\_ is uplifted, it makes a \_\_\_\_\_ shore line. Wave action then churns up \_\_\_\_\_ and deposits \_\_\_\_\_ at the line of breakers. Finally the waves \_\_\_\_\_ the barrier beach, pushing it toward \_\_\_\_\_, the \_\_\_\_\_ becomes narrower until it is \_\_\_\_\_ and the shore is regular again.

A drowned shore is \_\_\_\_\_ at first. Wave erosion undercuts \_\_\_\_\_, producing \_\_\_\_\_ and \_\_\_\_\_. Right under the surface of the water, a \_\_\_\_\_ is developed. The rock waste is \_\_\_\_\_ into a \_\_\_\_\_ and \_\_\_\_\_. Sand bars are formed across \_\_\_\_\_, which are ultimately \_\_\_\_\_ by deposits from land and \_\_\_\_\_, straightening \_\_\_\_\_.

Uplifted mountains may produce a regular \_\_\_\_\_ if \_\_\_\_\_.

In warm, shallow water, corals build \_\_\_\_\_. An atoll seems to be built around \_\_\_\_\_.

The Atlantic Coastal Plain has been \_\_\_\_\_ submerged in part, so that we find features of the emergent \_\_\_\_\_, like \_\_\_\_\_, as well as features of the submergence, like \_\_\_\_\_. Estuaries were formed by \_\_\_\_\_.

A good harbor must be \_\_\_\_\_, \_\_\_\_\_ deep water \_\_\_\_\_,



and must have facilities ———; it must ——— ice ———, and have access ———.

Submerged shores ——— harbors.

———, ———, and ——— owe their good harbors to drowned shore lines.

Lagoons on uplifted ——— sometimes make harbors, but these have many disadvantages. They are not ———, ———, and the entrance ———.

Artificial harbors are often formed by building ———.

### *Exercises*

1. Why does a newly uplifted coastal plain have a regular shore line?

2. How is a barrier beach formed? Why is it parallel to the shore?

3. What determines the width of a lagoon?

4. Describe the action of the waves on a barrier beach.

5. Why is a lagoon only a temporary shore feature? How is it finally destroyed?

6. Which shore of the United States is emergent? Cite features to prove it.

7. Why is a newly submerged coast irregular?

8. What is a spit? Why does it often curve?

9. What is a bay bar? Where is it formed?

10. How does a drowned shore finally become regular?

11. When is an emergent mountainous shore irregular? regular? Cite an example of each.

12. Considering the answer to question 11, when will there be good harbors on a mountainous coast? poor harbors?

13. What is a barrier reef? Where is the Great Barrier Reef?

14. What is an atoll?

15. Was the Atlantic Coastal Plain uplifted before or after it was submerged?

16. What features were developed by the uplift and by the submergence?

17. What is an estuary?

18. What is a harbor?

19. What makes a good harbor? Name three good harbors.

20. Compare the facilities and advantages of New York Harbor with the characteristics of a good harbor and rate it on the basis of 100%.

21. Name 5 of the best harbors in the world.

22. State at least two advantages of each harbor mentioned in the answer to question 21.

23. State two disadvantages of drowned valley harbors.

24. What are the advantages of a delta harbor? the disadvantages?

25. Name two delta harbors.

26. Name a fiord harbor. What are its advantages?

27. Why do lagoons usually make poor harbors? Name a lagoon harbor.

28. Mention an island harbor.

29. Mention two artificial harbors.

#### ★*Optional Exercises*

30. Give a short life history of an emergent shore line.

31. Why are bars formed *between* headlands on a drowned shore, while they are parallel to the shore on an emergent coast?

32. How is a barrier beach formed on a drowned shore?

33. Under what two conditions would a shore be irregular?

34. What kind of shore line is formed by a fault? What kind of harbors does this produce?

35. How are fiords formed? What kind of shore line do they make? What kind of harbors?

36. Show the historic relation between good harbors and civilization.

37. What is a crater harbor? What disadvantage has it?

## APPENDIX

### Maps and Map Projections

A map is a representation of a portion of the earth's surface on a plane or flat surface. Every great nation employs a body of men engaged in surveying and map making. In the United States the General Land Office has mapped most of the country in order to allot and sell the public domain. The United States Geological Survey is making an accurate large-scale map to show geological and relief features, rivers, lakes, and coasts. The portion of the earth represented on a map is indicated by latitude and longitude.

The *scale* of a map is the ratio between the length of a line on the map and the actual distance the line represents. A scale of 1 : 63,360 is equivalent to 1 inch to the mile, since 1 mile = 63,360 inches. On the United States topographic maps, the scale most frequently used is 1 : 62,500, which is about 1 inch to the mile.

The mapping of large areas presents peculiar difficulties because of the curvature of the surface, which is negligible for a small area, and the converging meridians. These difficulties are met, in part, by map *projections*.

**Map projections.** A projection is a flat picture, or representation, of what the observer sees in three dimensions, as far as that is possible. If light were made to shine on an object of which certain points only were opaque, the shadows of these points on a sheet of paper would be a projection. Some projections represent the *shapes* of different parts, others the *areas*, but none can accomplish both of these things at the same time. If the areas are equivalent, the shapes must be distorted.

**The orthographic projection.** In this type of map, points are determined by drawing lines from the object at right angles to the paper. These lines are parallel to each other, just as rays of sunlight would be (Fig. 334). An orthographic projection of the block 123456 is to be made on the sheet *ABCD*. The parallel dotted lines are the projection lines and 1'2'3'4' is the *projection*.

It is a view of the upper surface of the block as seen from a point far enough above, so that the lines of sight would be parallel to each other. This makes the projection the exact size of the upper surface of the block.

In similar manner, a side view may be projected on a vertical surface, like a wall, *ADEF*. By using horizontal projection lines we get figure 3''4''5''6'', which is the orthographic vertical projection of the block.

Figure 335 shows how to draw polar and equatorial projections of the earth by the orthographic method. In each of these projections we notice that distances are foreshortened near the edges. No scale of distances can apply to all parts of the map, but the projection is use-

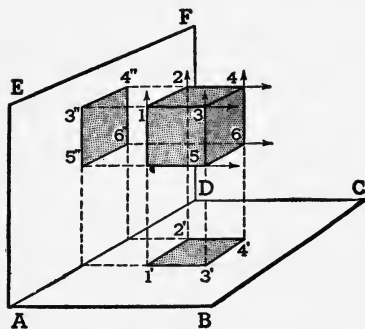

FIG. 334. Orthographic Projection

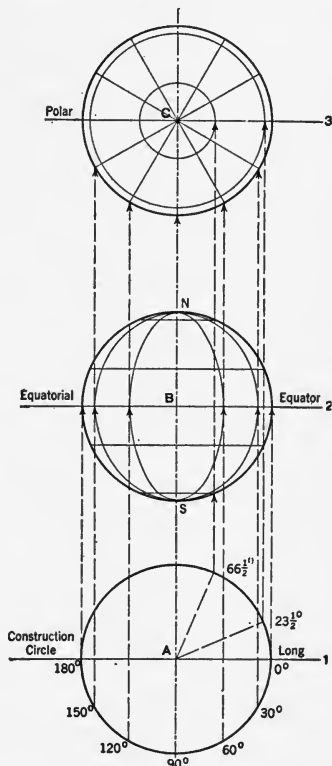

FIG. 335. Orthographic Projections of the Earth

ful because it shows the appearance of a hemisphere just as a globe does.

Figure 336 shows an orthographic projection of the western hemisphere. Notice the contraction of areas around the edges.

**Mercator's projection.** Figure 337 is a Mercator's projection of the entire earth. We begin its construction with a horizontal line that represents the length of the circumference of the earth ac-

cording to a given scale. If we divide this line into eighteen equal parts, each part will represent  $20^\circ$  of longitude and vertical lines through these points will represent meridians.

The meridians of the earth converge toward the poles, so that  $1^\circ$  at the equator is about 70 miles, whereas, at the poles,  $1^\circ$  is zero. At latitude  $60^\circ$ ,  $1^\circ$  of longitude is about 35 miles.

On Mercator's projection, the meridians are the same distance apart all over. Hence if  $1^\circ$  represents 70 miles at the equator, it should be only half that at latitude  $60^\circ$ , and much less as we approach the poles. Hence it is apparent there is great exaggeration of areas in high latitudes.

Mercator corrected the distortion that would occur in the shapes of land areas by making a degree of *latitude* twice as long at  $60^\circ$  as it is at the equator. This makes areas at  $60^\circ$  four times too large, but it preserves the true *shape* of the land, and *directions are correctly shown*. Because of this, Mercator's projection is much used for mariners' charts.

Degrees of latitude are correctly shown at the equator, but at other points the length of the degree is *increased* in exact proportion that a degree of longitude is decreased on the earth at the point in question. Note, in Fig. 337, the gradually increasing distance used to represent  $20^\circ$  of latitude. For example, the distance from  $60^\circ$  to  $80^\circ$  is twice as great as from  $40^\circ$  to  $60^\circ$ .

Compare the size and shape of Greenland in Fig. 337 with its shape in Fig. 338, in which the Mercator plan is not used.

**Mollweide projection.** In the Mollweide projection (Fig. 338) the equator is represented twice as long as the earth's axis, which will give correct areas. Meridians and parallels are equally spaced; the meridians are ellipses, and the parallels are straight parallel lines.

Shapes of land are distorted especially near margins and in high latitudes; but the map is pleasing to the eye and shows the entire earth.

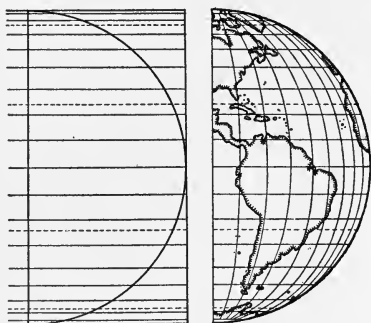

FIG. 336. Orthographic Projection of the Western Hemisphere

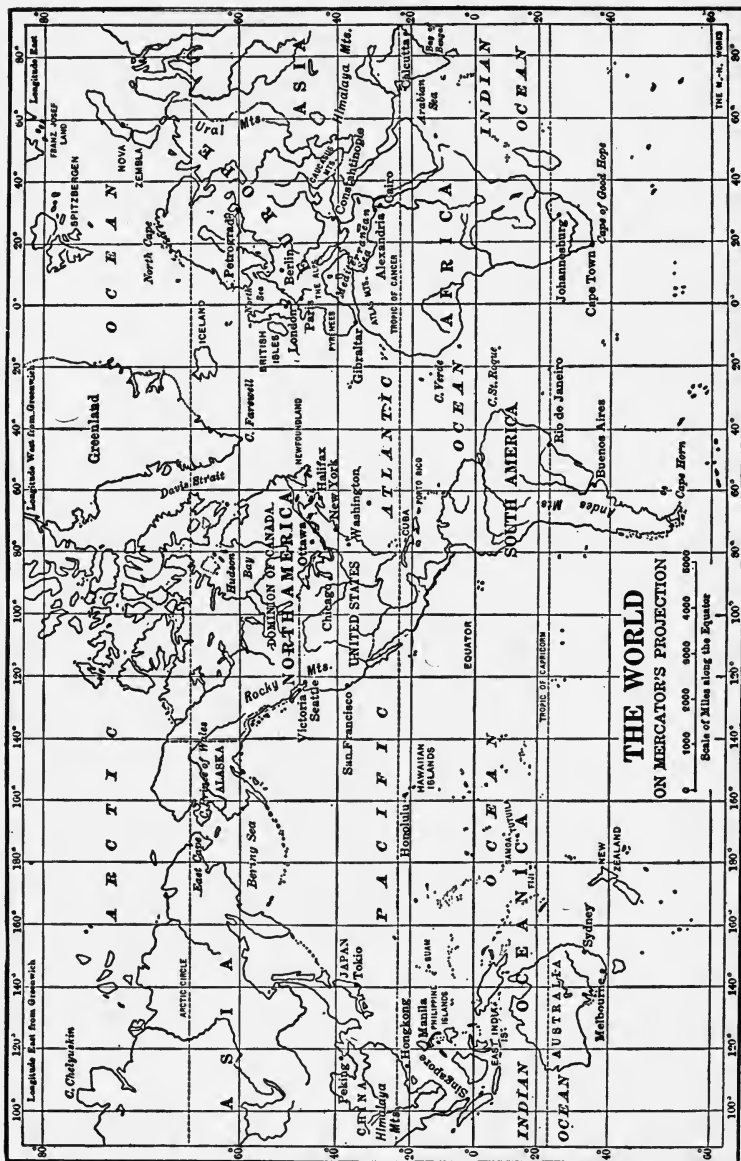

FIG. 337

A modification of the Mollweide projection is **Aitoff's projection** (Fig. 339). The meridians are farther apart at the center than at the margins and the parallels are slightly curved. This maintains equality of area while improving the shapes somewhat.

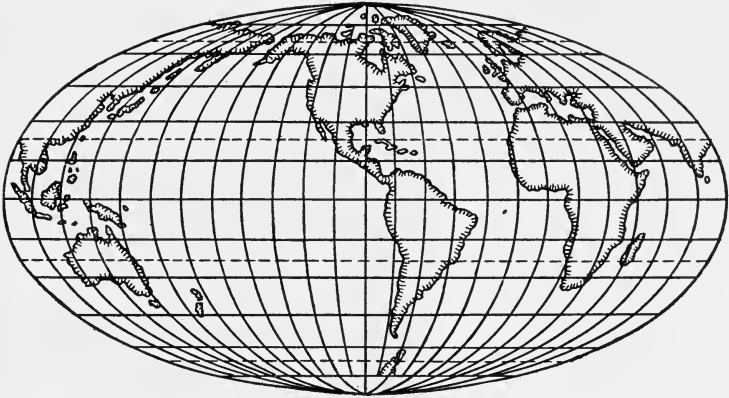

FIG. 338. Mollweide Projection

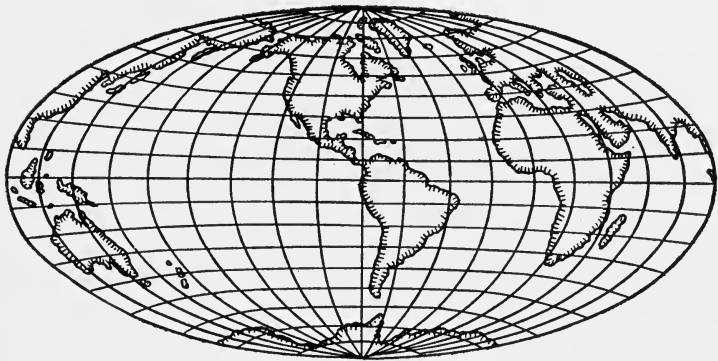

FIG. 339. Aitoff's Projection

**Globes.** Globes represent the whole earth. They show relative sizes of the land masses and their relative positions correctly, and directions are correctly indicated on them. It is not possible to make them large enough to show the amount of detail necessary for many purposes, although sections of globes have been made that show limited areas with sufficient detail for most purposes.

**Relief.** The elevations and depressions of the earth's surface constitute what is technically known as the *relief of the earth*. It is best represented by models in which a greater scale is used for the elevations and depressions than for horizontal distances. Models are expensive, cumbersome to handle, and limited to the representation of small areas.

Figure 340 shows one way of representing the relief of a region on a flat surface. Lines called *hachures* are drawn to indicate the paths that water would fol-

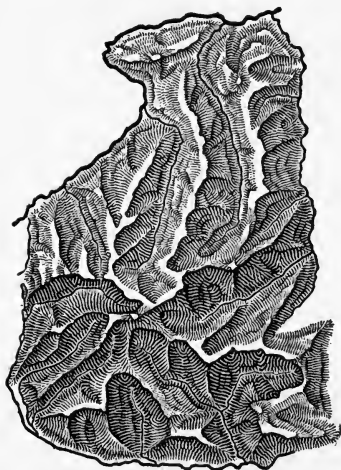

FIG. 340. Hachure Map of a Portion of the Austrian Alps

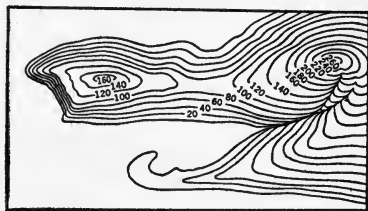

FIG. 341. A Contour Map of the Land Shown Above

low in flowing down the slopes. Sometimes *steep slopes* are indicated by short wide lines and gentle slopes by narrow lines farther apart.

Hachure maps give us a general idea of the relief of a region, but we cannot tell whether the ridges are a hundred feet high or thousands of feet high. This method was formerly used by the United States Coast Survey, but has been abandoned in favor of contour lines.

**Contours.** Lines connecting all points of equal elevation above sea level are called *contour lines* (Fig. 341). Each contour line represents what the shore line would look like if the sea rose to that elevation.

In a flat region there are few contours, while in a hilly region there will be many contours close together. When these become



too close to distinguish, a greater *contour interval* is used. A contour interval of five feet may be used for a flat region, because there are no great differences of elevation and contour lines will be far apart. In a hilly region, a five-foot interval may bring lines so close together that they cannot be distinguished; but a twenty-foot interval would require only one quarter the number of lines.

While contour maps do not represent relief to the eye as well as hachures, they are of far greater value, and by practice one soon learns to see the relief and to interpret the features shown in terms of physiography.

**Interpretation of topographic maps.** United States topographic maps are printed in colors to represent various features: black for everything built by man, like roads, houses, and bridges; blue for water, including man-made canals; and brown for contour lines.

If a map has a small contour interval, like five feet, and its general color is white, because the contour lines are far apart, the slope of the land is very gentle and the region is flat. If the contour interval is large and the map is rather brown in color, owing to a large number of contour lines, the region is elevated, probably mountainous, and slopes are steep. Whenever the contour lines are close together, the slope is steep. The top of a hill will be shown by closed contours.

Where contours bend convex to the highland, we find a river valley (Fig. 342). Where contours bend convex to the lowlands, we find a ridge. A young region will have young rivers with the contours massed along the courses of the rivers, whereas an old region will have few contours.

Details of topography are best studied on the maps themselves in the laboratory.

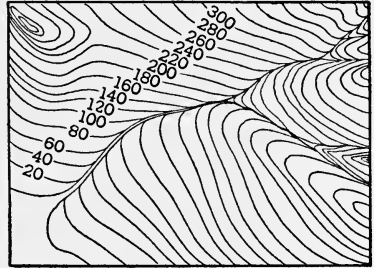

FIG. 342. Where contours form angles pointed uphill, we find a river valley.

## Terrestrial Magnetism and the Compass

The earth acts as if a huge magnet were buried in it. One pole of this magnet is found north of Hudson Bay, at latitude  $70^{\circ}$  N and longitude  $97^{\circ}$  W. The south magnetic pole is at latitude  $72^{\circ}$  S and longitude  $150^{\circ}$  E.

The mariner's compass consists of a light magnetized needle or rod, suspended on a pivot, so that it can swing in a horizontal plane. One end of this needle points toward the north magnetic pole of the earth, and it is this property which makes the compass a valuable instrument.

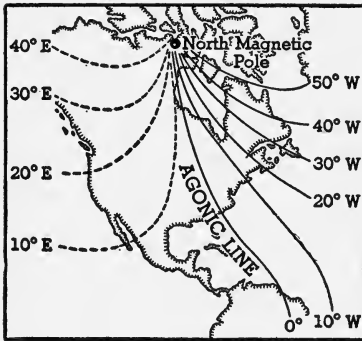

FIG. 343. Isogonic Lines

The direction of the compass needle is *nearly* north and south. In some places, however, this direction varies considerably from true north and south. This variation is called *magnetic declination*. If, for example, the compass needle points  $10^{\circ}$  west of the

north-south line at a given place, that place is said to have a  $10^{\circ}$  W declination.

Lines connecting places with the same declination are called *isogonic lines*; and lines connecting places of no declination are called *agonic lines* (Fig. 343). In attempting to determine direction by the compass, it is therefore necessary to know the magnetic declination for the particular place. One agonic line crosses the United States from Lake Superior through Ohio and Kentucky to South Carolina. On this line the compass needle points true north. At all places in the United States east of this line, the needle points west of north; that is, there is a west declination. At all places west of the agonic line there is an east declination. In Maine the declination is about  $20^{\circ}$  W, and in the state of Washington it is about  $20^{\circ}$  E.

If the magnetic declination were constant, the compass would be a more dependable instrument than it is. In 1500, when the great explorations were being made, an agonic line lay in the

middle of the Atlantic Ocean. In 1600, it ran from Finland to Egypt. In 1700, it returned to the Atlantic and now it runs through the United States.

The compass needle is abnormally deflected by masses of iron ore buried in the earth, by steel buildings, electric generators and other electrical machines, and by sun spots, which produce magnetic storms that completely upset compass readings.

On a steel boat where compass deflections are abnormal, the **gyrocompass** is used. *The gyrocompass points true north*, since its pointer is in no way influenced by the earth's magnetism, but rather by the earth's rotation.\*

The **earth inductor compass** depends upon the earth's magnetism, but is unaffected by magnetic declination. It consists essentially of a small electric generator turned by a wind motor, since it is used chiefly on airplanes. The armature of the generator cuts the earth's magnetic lines of force and generates a small current which is delivered to a sensitive galvanometer on the dashboard.

If the pilot wishes to go due west, he turns an indicator on the dashboard until it reads *West*. This moves the brushes of the generator so that no current is delivered as long as the plane is going west. The galvanometer will therefore register zero as long as the plane is headed west. But as soon as the direction is changed, the earth's magnetic lines of force will be cut at a different angle and the generator will deliver a current to the galvanometer. As soon as he is aware of the deviation of his galvanometer needle, the pilot changes his direction until the needle again reads zero.†

\* For a simple explanation of the action of the gyrocompass, see p. 364 of *Unified Physics* by Fletcher, Mosbacher and Lehman. McGraw-Hill.

† For a more complete explanation of the earth inductor compass, see p. 474 of *Unified Physics*.

## GENERAL REVIEW QUESTIONS\*

1. While streams are lowering their beds toward sea level, areas between streams are also being lowered. (a) Distinguish between weathering and erosion. (b) Name *three* agents of weathering that aid in lowering interstream areas. (c) Why are some interstream areas lowered more rapidly than others? (d) Would weathering be more rapid in mountain or plain areas? (e) What physiographic feature would finally be produced if this lowering of the surface continued long enough? (f) Explain why this physiographic feature is seldom produced.

2. In May, 1934, there was a heavy "dust storm" in southern New York State. (a) From what part of the United States did the dust come? (b) How was the dust transported? (c) How was the place of origin affected by the removal of this dust material? (d) State *two* possible reasons why such dust storms were not common in the past. (e) How does the origin of the loess in China compare with that of these dust deposits? (f) Name an area not previously mentioned where dust storms are frequent.

3. Transatlantic cables frequently have to be mended after earthquakes originating in the Atlantic. By experience the cable companies know where to look for the breaks. (a) What causes the earthquakes? (b) Why do the breaks in the cable usually occur in the same locality? (c) Name the instrument by which people in New York know when an earthquake is taking place in the Atlantic. (d) What ocean phenomenon frequently accompanies a submarine earthquake? (e) Name *two* great earthquake belts of the earth. (f) Name a locality in the United States, not included in the major earthquake belts, where a destructive earthquake has occurred. (g) Why are there many volcanoes in the major earthquake belts?

4. Give a physiographic reason for each of the following: (a) Fogs occur off the coast of Newfoundland. (b) Coal has been found in the Antarctic. (c) The return of Halley's comet, unlike that of most comets, can be predicted. (d) Deltas are more common in lakes than along the seacoast. (e) Relative humidity usually decreases as the air becomes warmer. (f) Limestone frequently forms ridges in arid regions, although it forms valleys in humid regions. (g) The port of Hammerfest, Norway, although situated within the Arctic Circle, is open throughout the year.

5. (a) How are igneous rocks formed? (b) Name an igneous rock. (c) Give a definite locality where the igneous rock named in answer to b

\* Adapted from New York State Regents Examinations.

may be found. (d) Name (1) a sedimentary rock of chemical origin, (2) a sedimentary rock of mechanical origin, (3) a sedimentary rock of organic origin. (e) Explain how *one* of the sedimentary rocks named in answer to *d* was formed. (f) To what class of rocks does marble belong?

6. The elements of which the earth is composed are also found in the sun. (a) Name a theory that attempts to prove that the material of the earth came from the sun. (b) Who was the author of the theory named in answer to *a*? (c) What is meant by sun spots? (d) Name *three* types of bodies other than planets in the solar system. (e) State *two* important characteristics of the planet Saturn.

7. Some of the statements below are true and some are false. Copy the letters *a, b, c, etc.*, and write the letter *T* next to each true statement. If the statement is false, write the word or phrase that should be substituted for the italicized word or phrase to make the statement correct. (a) Longitude is measured from the *international date line*. (b) *Neap* tides occur at the time of new and full moon. (c) If the angular elevation of the North Star is 60 degrees, the latitude of the place is 43 *degrees N*. (d) The steeper the slope, the faster the rain will *sink in*. (e) Vegetation helps to prevent *wind erosion*. (f) If the velocity of a stream is doubled, it can carry *more* sediment. (g) The ocean currents in the South Atlantic move in a *clockwise* direction. (h) The valley of a stream is lengthened by *headward erosion*. (i) The Delaware River at the water gap is narrow because the rock is *resistant*. (j) Ocean waves are caused by the *wind*.

8. Which of the words or expressions in parentheses makes each of the following statements true? (a) An iceberg breaks off from (floe ice, névé, glacier front). (b) A healthful relative humidity for indoor work is (80%, 20%, 50%, 35%). (c) The stars around the North Star (appear to revolve, actually revolve, appear to remain fixed). (d) The largest planet is (Venus, Mercury, Jupiter, Saturn). (e) On March 21, in our latitude the sun appears to rise in (the southeast, the northeast, the east, the northwest). (f) Some sandstones are coarser than others because (they were deposited by swifter streams, they have not been weathered, they were deposited far from land).

9. Which of the following statements is true? (a) The rotation of the earth causes the tidal bulge to pass around the earth. (b) Different constellations of stars are visible at different seasons because of the revolution of the earth. (c) If the earth's axis were inclined 30 degrees, New York State would have more hours of sunlight on June 21. (d) On June 21, at the Tropic of Capricorn the noon sun casts no shadow. (e) The rotation of the moon causes its phases. (f) All places on the same meridian see the noon sun at the same elevation. (g) A mineral common in granite is feldspar. (h) Elevations on a topographic map are shown by lines called isobars.

10. Copy the following, filling the blanks with the correct words or expressions.

As the center of a "low" approaches Albany, N. Y., the winds shift to a \_\_\_\_\_ quarter, the barometer moves \_\_\_\_\_, and the mercury in the thermometer moves \_\_\_\_\_. These things indicate that (fair, stormy) \_\_\_\_\_ weather is approaching. If the center of the low passes to the south, the wind will shift to a \_\_\_\_\_ quarter. After the low has passed, the barometer moves \_\_\_\_\_, the thermometer \_\_\_\_\_, and we have \_\_\_\_\_ weather. Weather conditions may be read on weather maps from lines called \_\_\_\_\_, which connect places having equal air pressure, and from lines called \_\_\_\_\_, which connect places having equal temperature.

11. Give a physiographic reason for each of the following statements: (a) A corked bottle thrown into the Pacific Ocean off the coast of Japan was picked up near San Francisco. (b) Early on a clear morning the grass in a field was found to be very wet although no rain had fallen for several days. (c) During a tornado the walls of a building fell outward. (d) In some sections of the tropics people frequently make appointments by saying, "I will meet you after the rain next Tuesday." (e) An eclipse of the sun which was visible on the Pacific Ocean began on Wednesday, February 14, 1934, and ended on Tuesday, February 13, 1934. (f) The ocean floor is smoother than the land areas. (g) The shape of the earth is an oblate spheroid.

12. Account for the rainfall or the lack of rainfall in each of the following places: (a) eastern coast of Central America, (b) Central Australia, (c) northwest coast of the United States, (d) Amazon valley of Brazil, (e) Great Basin of the United States, (f) British Isles, (g) New York City.

13. The plains regions of the United States, Europe, and Asia are better adapted to living conditions than the level areas of plateaus. (a) Explain why this is true with regard to (1) climate, (2) ground-water conditions, (3) soil conditions, (4) location of roads and railroads. (b) What is the essential difference between a plain and a plateau? (c) How do the river valleys of plateaus differ from those of plains?

14. The Grand Canyon in Arizona is noted for its size and grandeur. It is over 200 miles long and 6,000 feet deep. (a) Is the Grand Canyon located in a plain, a plateau, or a mountain area? (b) What is the rock structure of this region? (c) How did the Canyon reach its great depth? (d) Why is the Canyon wider at the top than at the bottom? (e) Why do the walls of the Canyon show alternate steep and gentle slopes? (f) Account for the fact that rocks of marine origin are found near the top of the Grand Canyon.

15. The ocean waters cover nearly three fourths of the earth's surface. (a) What is the average depth of the ocean? (b) Mention *one* mineral other

than common salt that is found in sea water. (c) Mention *two* gases found in sea water. (d) Explain why sea water is salty. (e) Explain why some parts of the sea are more salty or less salty than others. (f) How does the topography of the ocean floor compare with the topography of land areas?

16. Venus is observed through a telescope to have phases like those of the moon. (a) To what class of heavenly bodies does Venus belong? (b) To what class does the moon belong? (c) Why is Venus visible? (d) Compare Venus with the earth as to size and relative distance from the sun. (e) Name in order *four* phases of the moon.

17. Rearrange the words in column A so that each one is on the same line with the word or expression in B that is most closely related to it.

<i>Column A</i>	<i>Column B</i>
1 seismograph	elements in the sun
2 barograph	wind gauge
3 spectroscope	altitude of the sun
4 anemometer	continuous temperature record
5 rain gauge	humidity
6 planetarium	longitude
7 thermograph	earth tremors
8 sextant	movements of heavenly bodies
9 hygrometer	atmospheric pressure
10 chronometer	precipitation

18. Below are the names of several cities with the meridians from which their standard time is determined. Suppose that it is 10 A.M. Saturday in our eastern standard time belt; what is the time and the day in each of the following cities? (a) Philadelphia, Pa.,  $75^{\circ}$  W, (b) London, England,  $0^{\circ}$ , (c) Sydney, Australia,  $150^{\circ}$  E, (d) Manila, Philippine Islands,  $120^{\circ}$  E, (e) Calcutta, India,  $90^{\circ}$  E.

19. Some of the statements below are true and some are false. If the statement is true, write nothing; but if it is false, write the word or phrase that should be substituted for the italicized word or phrase to make the statement true. (a) Rain occurs principally in the *northeast* quadrant of a low-pressure area. (b) The summer monsoon over India blows from the *southwest*. (c) Tornadoes occur *more frequently* over tracts of level land than in mountains. (d) Tidal range in the Bay of Fundy is 50 feet.

20. Copy the following, filling each of the blanks with the correct word or expression.

As the earth moves in its orbit during its period of ———, the axis is inclined ——— degrees away from a line perpendicular to the orbit. Since the ——— pole of the axis always points to ———, every position of the axis is always ——— to every other position of the axis. This causes the shifting of the ——— ray of the sun over a belt ——— degrees wide,

between the dates of the solstices on ——— and ———. The northern limit of this belt is the ———.

21. Copy the following table and fill in columns *A* and *B*.

	<i>Column A</i> Cause	<i>Column B</i> Example
Waterfall	.....	.....
Irregular shore line	.....	.....
Block mountains	.....	.....
Lacustrine plain	.....	.....
Valley glaciers	.....	.....
Geysers	.....	.....

22. (a) Make a labeled diagram to show the umbra and penumbra of the moon's shadow during an eclipse of the sun. (b) What phase of the moon is indicated in this diagram? (c) Name the tide that will occur when the moon is in this position. (d) What part of the shadow produces a total eclipse?

23. (a) Explain the process by which residual granite boulders are rounded by exfoliation (the peeling off of the outer surface). (b) Distinguish between mechanical and chemical weathering. (c) Mention *one* factor that determines the rate of weathering. (d) What is meant by residual mantle rock? (e) Name *three* agents that form residual mantle rock.

24. Explain the difference in the meaning of the terms in each of the following pairs: (a) weathering — erosion, (b) ocean creep — ocean current, (c) river system — river basin, (d) pothole — sinkhole, (e) denudation — diastrophism, (f) igneous — metamorphic, (g) fringing reef — spit.

25. After a rain some of the water sinks into the ground, forming ground water. (a) Explain what is meant by the water table. (b) Show by a labeled diagram the relation of the water table to (1) a permanent well, (2) a temporary well. (c) Give *three* conditions necessary to form an artesian well. (d) Mention *one* way in which ground water is destructive. (e) Mention *one* way in which ground water is constructive.

26. Rearrange the items of column *A* so that each one is on the same line with the word or expression in *B* that is most closely related to it.

<i>Column A</i>	<i>Column B</i>
1 anticline	gravity deposit
2 pervious	eclipses
3 igneous	equatorial diameter
4 zenith	lets water seep through
5 7,926 miles	condensation
6 offshore bar	point overhead
7 dew point	river deposit
8 talus	lava flow



9 umbra shadow	wave deposit
10 natural levee	upfold of rock

27. Rearrange the items of column *A* so that each one is on the same line with the word or expression in *B* that is most closely related to it.

<i>Column A</i>	<i>Column B</i>
1 Mars	largest planet
2 Neptune	a satellite
3 Venus	eighth in distance from the sun
4 Earth	most distant planet
5 Saturn	orbits between Mars and Jupiter
6 Jupiter	nearest the sun
7 Asteroids	shows "canals" and white polar caps
8 Moon	size most like earth
9 Pluto	average period of rotation 24 hours
10 Mercury	rings around equatorial region

28. Account for the formation of each of the following physiographic features in New York State: (a) the ridge of hills along the north shore of Long Island, (b) the Finger Lakes, (c) the plain bordering the southern shore of Lake Ontario, (d) the Palisades of the Hudson, (e) the Niagara gorge, (f) Rockaway beach, (g) New York Harbor.

29. Give the difference in the meaning of the terms in each of *five* of the following pairs: (a) perihelion — aphelion, (b) weather — climate, (c) lava — volcanic ash, (d) planets — planetoids, (e) civil day — conventional day, (f) tributaries — distributaries, (g) alluvial — lacustrine.

30. Give a physiographic explanation for *each* of the following statements: (a) Drills used in cutting into certain types of rock are often tipped with pieces of diamond. (b) A thermogram for a period of 24 hours showed the lowest temperature shortly before sunrise. (c) During a certain summer the farmers near a town had to get water from the town well because their own wells were dry. (d) Offshore bars may become bay-mouth bars. (e) The Mohawk-Hudson Valley was once an outlet for the Great Lakes.

31. The bed of Great Salt Lake is covered with a layer of pure salt. (a) What caused the layer of salt to form? (b) What is the source of the salt in the water of the lake? (c) Give a brief history of Great Salt Lake, including *one* evidence which scientists have found to indicate that the lake has not always been the same. (d) Explain *two* ways in which lakes in the eastern part of the United States may be destroyed or disappear. (e) Name an extinct lake.

32. (a) State *four* conditions that control the climate of a region. (b) For *each* of the following, state how a climatic control has caused the climate of the two places to differ: (1) St. Paul, Minn., and Boston, Mass.,

(2) San Francisco and New York City, (3) Mexico City and the eastern coast of Mexico, (4) Panama and Chicago. (c) Explain why winters in the northern hemisphere are not so cold as winters in the southern hemisphere.

**33.** Give a physiographic explanation for each of *five* of the following statements: (a) A layer of shale was changed to slate near a granite intrusion. (b) It is calculated that the reservoir of Boulder Dam will be filled with silt in 200 years. (c) Western Oregon has more rainfall than North Dakota. (d) A cloudy sky hinders the formation of dew or frost. (e) It is often impossible to read the inscriptions on very old tombstones. (f) The great deserts of Africa and Australia are situated in the trade-wind belts.

**34.** The effect of erosion is opposed by forces in the earth's interior. (a) State *two* methods by which forces in the earth's interior change the earth's surface. (b) Name *two* surface features formed by forces from the earth's interior. (c) Name *two* agents of erosion. (d) State *two* evidences to show that the work of erosion is opposed to the forces of the earth's interior. (e) How does weathering aid the work of erosion?

**35.** During the period when most of the northern part of North America was covered by glaciation, the Rocky Mountains were being eroded by extensive valley glaciers.

Compare glaciation in these two regions, using the following topics: (a) The place where the ice originated in each region. (b) The general direction of the movement of the ice in each region. (c) The names of *two* types of deposits common to each region. (d) The name of *one* feature due to destructive action of the valley glacier but not produced by the continental glacier.

**36.** Give a physiographic reason for each of *five* of the following: (a) Beach grass has been planted along the boulevard at the Jones Beach State Park on the southern shore of Long Island. (b) During a windstorm the windshield of an automobile became etched so that it was no longer transparent. (c) Large forested areas along the headwaters of streams are preserved by state governments. (d) The water is deepest at the outside of the curves of the lower Mississippi. (e) A man in St. Louis hears on the radio at 8 o'clock a program broadcast from New York City at 9 o'clock. (f) Astronomers have seen only one side of the moon.

**37.** In August, 1933, a destructive hurricane affected Norfolk, Va. (a) What causes the wind to reach hurricane force? (b) What was the approximate barometer reading in Norfolk when the center of the hurricane was over the city? (c) Why does the direction of the wind change as the hurricane passes? (d) Where is the probable origin of hurricanes that affect the Atlantic coast? (e) What is the usual path of these Atlantic hurricanes? (f) What caused clear weather in Canada at the time when the Atlantic coast was swept with heavy rains?

38. Copy the following table and classify the following terms by placing *each* in the proper space in the table under the agent to which it is chiefly due, and indicating whether it is formed by the constructive (building-up) action or the destructive (wearing-away) action of that agent: sinkholes, drumlins, sand dunes, hanging valleys, flood plain, loess of China, wind gap, stalagmite, peneplain, Carlsbad caverns.

	<i>Streams</i>	<i>Wind</i>	<i>Glaciers</i>	<i>Ground water</i>
Constructive action				
Destructive action				

39. Show by means of a labeled diagram the nature of each of the following: synclinal ridge, young river valley, geologic fault, stalactite, eroded plateau, dome mountain, oxbow lake.

40. Copy column *B* and after *each* item write the number of the word or phrase in *A* that is most closely related to it.

<i>Column A</i>	<i>Column B</i>
1 dust	Venus
2 constellation	oxbow lake
3 young river	folded mountains
4 parallel scratches on rock	humidity
5 mineral	calcite
6 angle of elevation of North Star	glaciers
7 igneous rock	latitude
8 diastrophism	color of sunset
9 hygrometer	spring tide
10 planet	granite
11 old river	
12 new moon	

41. Make a drawing indicating the relation of the earth to the sun on June 21. Indicate by *lines* and *labels* the following: the earth's axis, the daylight circle, the equator, the Arctic Circle, the Antarctic Circle, the tropics of Cancer and Capricorn, the point of vertical ray (direct ray), the number of degrees of inclination of the axis. In your drawing indicate by shading the half of the earth that is out of the sunlight.

42. (a) What is meant by dew point? (b) Describe an experiment by means of which dew point may be found.

43. (a) Name *five* weather conditions indicated on a weather map. (b) Give for each of *three* of the conditions mentioned the instrument used in recording it. (c) State *two* ways in which weather information is important in aviation.

44. Give a brief explanation of each of the following situations: (a) A person digging into a sand dune discovers the remains of a building. (b) The valley of the Hudson River continues out under the Atlantic Ocean for many miles. (c) A huge boulder of granite weighing about 50 tons is found resting on a hill of sandstone in New York State. (d) The shells of marine animals are found embedded in solid rock near a mountain top. (e) Winter in the northern hemisphere occurs when the earth is closest to the sun. (f) Although the British Isles are at about the same distance north of the equator as Labrador, they have a much milder climate. (g) Although the ice in a glacier moves slowly forward, sometimes the front of the glacier recedes.

45. Give *four* evidences that a great ice sheet once covered nearly all of what is now New York State. Explain how the direction of the movement of this continental glacier is determined. How may the soil left behind when a glacier has receded be distinguished from ordinary residual soil? Why do regions that have been glaciated usually contain many more lakes than nonglaciated regions?

46. Give a reason why each of the following statements is true or not true: (a) Coal is an igneous rock because it burns. (b) Streams deposit material where the current flows most swiftly. (c) A degree of longitude is shorter near the north pole than near the equator. (d) People and objects are kept on the earth by the force of the earth's magnetism. (e) Large caves are frequently found in limestone. (f) The tides are highest when the moon is in first or last quarter.

47. The Panama Canal Zone has a wet and a dry season caused by the shifting of the planetary winds. (a) Why do the wind belts shift? (b) Give *three* conditions that produce the wet season at Panama. (c) Name the planetary winds that cause the dry season. (d) Explain why the winds mentioned in answer to *c* are drying winds. (e) Name another region that has a climate similar to that of Panama.

48. Copy the statements in *each* of the following groups, arranging the events in the order of their logical sequence:

(a) The Palisades of the Hudson

The igneous rock solidified with columnar structure.

Talus slopes were formed.

The igneous rock was affected by weathering.

Molten igneous rock flowed between sedimentary layers.

Erosion removed the overlying rock.

## (b) The Yellowstone geysers

The geyser shoots into the air.

Ground water dissolves part of the surrounding rock.

The overflow deposits geyserite (mineral matter) in the geyser basin.

Decreased pressure suddenly changes the heated water to steam.

Rain water sinks into the ground and becomes heated.

49. Copy the following, filling the blanks with the correct word or expression:

Rain water seeps into the ground and becomes what is known as \_\_\_\_\_ water. As this water moves through decaying organic matter in the soil, it takes into solution the gas \_\_\_\_\_. In limestone regions this solution reacts chemically on the calcium carbonate or limestone and removes it as calcium bicarbonate. This causes cracks in the rocks to \_\_\_\_\_ and leaves \_\_\_\_\_ in the limestone. Changes of temperature or pressure or sudden shock cause the soluble calcium bicarbonate to give off \_\_\_\_\_ and \_\_\_\_\_. The residue builds formations known as \_\_\_\_\_ and \_\_\_\_\_. Two states famous for these limestone formations are \_\_\_\_\_ and \_\_\_\_\_.

50. Which of the following statements are true? Explain. (a) Ocean currents have a clockwise motion in the northern hemisphere. (b) Sea water freezes at the same temperature as fresh water. (c) Tidal range is the same for every day in the year. (d) Currents are formed in the Indian Ocean by the monsoon winds. (e) The horse latitudes are regions of abundant rainfall. (f) All places on the same parallel of latitude have the same climate. (g) Climate in the past was always the same as climate of today. (h) In the temperate zones, daily weather changes are due to pressure changes. (i) Rising air currents during a thunderstorm are caused by local high pressure. (j) The rotation period of the moon is  $27\frac{1}{3}$  days.

51. Copy column B and at the left of each item write the number of the word or expression in A that is most closely related to it.

<i>Column A</i>	<i>Column B</i>
1 halo	asteroids
2 186,000,000	rainfall
3 time belt	diameter of earth's orbit
4 freezing point	lunar eclipse
5 windward slopes	proof of earth's rotation
6 no longitude	refraction of light
7 full moon	solar time
8 sundial	15 degrees wide
9 star trails	north and south poles
10 planetoids	0° Centigrade

52. Which of the words or expressions in parentheses makes each statement true? (a) A fleecy mass of ice particles at a high altitude is called a (cirrus, cumulus, stratus) cloud. (b) If one is traveling westward and it is Tuesday just east of the international date line, it is (Monday, Tuesday, Wednesday) just west of the line. (c) Morainal material tends to accumulate on a valley glacier chiefly (at the head, evenly over the surface, near the sides). (d) On March 21, an Eskimo living in northern Alaska would have (24 hours, 12 hours, 6 hours, 0 hours) of sunlight. (e) A mineral which has a shell-like fracture is (quartz, mica, calcite). (f) A violent circular windstorm of small area is a (chinook, tornado, anticyclone). (g) An instrument used in determining latitude is the (sextant, spectroscope, chronometer).

53. Select *five* of the following names and write a statement that will show that you are familiar with the work of each man selected: Chamberlin, Pope Gregory, Fahrenheit, Foucault, Laplace, Mercator, Byrd, Ferrel, Piccard.

54. (a) What is meant by the geographic cycle of a mountain? (b) Copy the table below and complete it by writing the following characteristics in the proper columns: mesas, slightly uplifted sea bottom, low relief and deep residual soil, avalanches and landslides, high flat-topped divides, rounded peaks, ruggedly dissected surface in horizontal rock, monadnocks.

	<i>Plateau</i>	<i>Mountain</i>	<i>Plain</i>
Young			
Mature			
Old			

55. Give a physiographic reason for each of *five* of the following statements: (a) Anthracite coal is found only in regions of folded and disturbed strata. (b) There are no valley glaciers in Australia. (c) If time belts and stops are disregarded, the flying time of a westbound plane across the United States is longer than that of an eastbound plane. (d) Earthquakes occur frequently in California. (e) There are fossil coral reefs in New York State. (f) Isotherms follow the parallels of latitude more closely over the ocean than over the land.

56. Every stream is engaged in the three processes of (1) vertical downcutting or degrading, (2) upbuilding or aggrading, and (3) lateral cutting or planation. (a) Explain *one* effect of each of these processes on the stream valley. (b) State *one* cause of upbuilding by rivers. (c) Make a

labeled diagram of a mature stream to show a condition under which up-bulding and cutting may take place at the same time.

57. Three regions in the United States having swampy areas are (1) Minnesota, (2) Florida, and (3) the Mississippi Valley section of Louisiana. (a) Give the origin of the swampy regions in each of these three localities. (b) What is the relationship of the water table to swamps? (c) Explain how a lake may become a swamp. (d) What is the economic importance of the swamps that existed millions of years ago in Pennsylvania?

58. Assume that you are guiding a group of people on an automobile trip through your state. Mention *four* physiographic features, no two of the same origin, that you would point out to them and give a brief explanation of the formation of each feature.

59. In each of the following groups there is *one* word or phrase that includes all the others in the group. What is this word or phrase in each case?

- (a) mesa, butte, monadnock, resistant rock, tableland
- (b) monsoons, polar whirls, southeast trades, terrestrial winds, prevailing northwesterlies
- (c) soil creep, action of gravitation, air pressure, glacial movement, talus
- (d) intrusion, vulcanism, eruption, lava flow, igneous rock
- (e) natural levees, alluvium, fans and cones, flood plains, deltas
- (f) barrier reef, atoll, Bermuda coral, fringing reef
- (g) sandstone beds, lake deposits, strata, plateau structure, deposits on continental shelf
- (h) solar eclipse, moon's shadow, penumbra, new-moon phase, corona
- (i) iceberg, rock flour, névé, crevasse, glacier
- (j) quartz, mica, granite, feldspar, hornblende

60. Which of the following statements is true? (a) The moon has an atmosphere. (b) Earthquakes are characteristic of old mountains. (c) The line representing the earth's axis in December is parallel to the line representing the earth's axis in June. (d) If the inclination of the earth's axis were increased to  $30^\circ$ , winters in the northern hemisphere would be colder. (e) Bodies weigh slightly more in the equatorial region than at the poles. (f) Observation of sun spots proves that the sun rotates. (g) Places west of a given meridian have later time than places on the meridian. (h) A region of high relief should be mapped with a large contour interval. (i) Streams deposit material where the current flows swiftly. (j) Wind erosion is active in humid regions.

## HELPFUL REFERENCE BOOKS

GIVEN BY CHAPTERS

1. Hobbs. *Earth Evolution and Its Facial Expression*. Macmillan.  
Barrell. *Origin of the Earth and Man*. Yale Univ. Press.  
Jeffreys. *The Earth*. Cambridge Univ. Press.  
Pirsson and Longwell. *Outlines of Physical Geology*. Wiley.  
Jeans. *The Universe Around Us*. Macmillan.  
Wegener. *Origin of Continents and Oceans*. Dutton.
2. Hawkins. *Book of Minerals*. Wiley.  
Loomis. *Field Book of Common Rocks and Minerals*. Putnam.  
Pirsson and Knopf. *Rocks and Rock Minerals*. Wiley.  
Clarke. *Data of Geochemistry*. Bull. 695, U.S.G.S.
3. Tarr. *Introductory Economic Geology*. McGraw-Hill.  
*Minerals Yearbooks* U. S. Dep't of the Interior.
4. Croneis and Krumbein. *Down to Earth*. Univ. of Chicago Press.  
Merrill. *Rocks, Rock Weathering and Soils*. Macmillan.  
Ramann. *Evolution and Classification of Soils*. Heffer & Sons.  
Cambridge.
5. Free. *Movement of Soil Material by the Wind*. Bull. 68, U. S. Bureau of Soils. 1911.  
Reports of the Soil Conservation Service. Washington, D. C.  
Merrill. *Rocks, Rock Weathering and Soils*. Macmillan.  
Ramann. *Evolution and Classification of Soils*. Heffer & Sons.  
Cambridge.  
Whitney. *Soil and Civilization*. Van Nostrand.
6. Gilbert. *Rate of Recession of Niagara Falls*. Bull. 306, U.S.G.S.  
Powell. *Exploration of the Colorado River of the West and Its Tributaries*. Washington, 1875.
7. Russell. *Rivers of North America*. Putnam.  
Gilbert. *Report on the Geology of the Henry Mts*. U.S.G.S.  
Hobbs. *Earth Features and Their Meaning*. Macmillan.
8. Beman. *Flood Control*. N. Y., 1928.  
Cline. *Floods in the Lower Mississippi Valley*. New Orleans, 1927.  
Mississippi River Commission, Annual Reports.



9. Tutton. *The Natural History of Ice and Snow*. Kegan Paul. London.  
Hobbs. *Characteristics of Existing Glaciers*. Macmillan.  
Tarr and Martin. *Alaskan Glacier Studies*. Nat. Geog. Soc., Washington. 1914.  
Coleman. *Ice Ages, Recent and Ancient*. Macmillan.  
Wright. *The Ice Age in North America*. Oberlin, Ohio. 1911.  
U. S. Coast Guard. *International Ice Observation and Ice Patrol Service in the North Atlantic Ocean*. Bull. of the Navy Dep't.  
Gilbert. *Glaciers and Glaciation of Alaska*. Harriman Alaska Expedition. Vol. 3, 1904.  
Leverett and Taylor. *The Pleistocene of Indiana and Michigan, and the History of the Great Lakes*. U.S.G.S. 1915.
10. Meinzer. *The Occurrence of Ground Water in the U. S.* Water Supply, Paper 489, U.S.G.S.  
Lee. "Discoveries in Carlsbad Cavern." *Nat. Geog. Mag.*, Vol. 48, 1925.  
Davis. *Origin of Limestone Caverns*. Bull. Geol. Soc. Am. Vol. 41, 1930.  
Hovey. *Celebrated American Caverns*. Rob't Clarke & Co. Cincinnati.  
Clarke. *Data of Geochemistry*. Bull. 695, U.S.G.S.
11. Russell. *Lakes of North America*. Boston. 1895.  
Salisbury. *Physiography*. Holt.  
Fenneman. *The Lakes of Southeastern Wisconsin*. Wis. Geol. Survey. Bull. 8. 1910.  
Gilbert. *Lake Bonneville*. U.S.G.S. Monograph 1. 1890.  
Leverett and Taylor. *The Pleistocene of Indiana and Michigan, and the History of the Great Lakes*. U.S.G.S. 1915.
- 12 and 13. Finch and Trewartha. *Elements of Geography*. McGraw-Hill.  
Hobbs. *Earth Features and Their Meaning*. Macmillan.  
Croneis and Krumbein. *Down to Earth*. Univ. of Chicago Press.
14. Gilbert. *Earth Movements in the Great Lakes Region*. U.S.G.S. 18th Annual Rep., Part II, pp. 601-647.  
Lahee. *Field Geology*. McGraw-Hill.  
Tarr and Martin. *Recent Changes of Level in the Yakutat Bay Region, Alaska*. Bull. Geol. Soc. Am. Vol. 17, 1906.

15. Hobbs. *Earth Evolution and Its Facial Expression*. Macmillan.  
 Geikie. *Mountains, Their Origin, Growth and Decay*. Van Nostrand.  
 Gilbert. *Report on the Geology of the Henry Mts.* U.S.G.S. 1877.  
 Hobbs. *Earth Features and Their Meaning*. Macmillan.  
 Joly. *Surface History of the Earth*. Oxford Univ. Press.
16. Hobbs. *Earthquakes*. Appleton.  
 Hobbs. *Earth Features and Their Meaning*. Macmillan.  
 Daly. *Our Mobile Earth*. Scribner.  
 Lawson and Others. *Report on the California Earthquakes of  
 Apr. 18, 1906*. Pub. No. 87, Carnegie Inst. of Washington.  
 Vol. 1, 1908.
17. Russell. *Volcanoes of North America*. Macmillan.  
 Croneis and Krumbein. *Down to Earth*. Univ. of Chicago Press.  
 Hitchcock. "Hawaii and Its Volcanoes." *Hawaiian Gazette*.  
 Honolulu, 1909.  
 Tyrrell. *Volcanoes*. Butterworth. London. 1931.  
 Iddings. *Problem of Volcanism*. Yale Univ. Press.  
 Hobbs. *Earth Evolution and Its Facial Expression*. Macmillan.  
 Day. *Physics of the Earth. Volcanology*. Bull. 77, Nat. Research  
 Council, Washington.
18. Croneis and Krumbein. *Down to Earth*. Univ. of Chicago Press.  
 "How Old Is the Earth?" *Sci. American*, Feb. 1930, pp. 110-113.  
 Holmes. *Age of the Earth*. Benn's Sixpenny Library. London.  
 1927.  
 Barrell. *Rhythms and Measurements of Geologic Time*. Bull. Geol.  
 Soc. Am. Vol. 28, 1917, pp. 745-904.  
 Barrell. *Evolution of Earth and Man*, pp. 1-46. Yale Univ. Press.  
 Schuchert. *Outlines of Historical Geology*. Wiley.  
 Shimer. *Introduction to the Study of Fossils*. Macmillan.  
 Miller. *Introduction to Historical Geology*. Van Nostrand.
19. Johnson. *Mathematical Geography*. American Book.  
 Unstead and Taylor. *General and Regional Geography*. Philip  
 and Son. London.  
 Jeans. *The Universe Around Us*. Macmillan.  
 McCready. *A Beginner's Star Book*. Putnam.  
 Mitchell and Abbot. *The Fundamentals of Astronomy*. Van  
 Nostrand.
20. Harrison. *Daylight, Twilight, Darkness and Time*. Silver, Bur-  
 dett.  
 Johnson. *Mathematical Geography*. American Book.

21. Jones. *General Astronomy*. Longmans, Green.  
Todd. *New Astronomy*. American Book.
22. Abbot. *The Sun*. Appleton.  
Shapley. *The Universe of Stars*. Harvard Observatory.  
Todd. *New Astronomy*. American Book.  
Jones. *General Astronomy*. Longmans, Green.
23. Finch and Trewartha. *Elements of Geography*. McGraw-Hill.  
Mill. *The Realm of Nature*. Murray. London.  
Humphreys. *Physics of the Air*. McGraw-Hill.
24. Finch and Trewartha. *Elements of Geography*. McGraw-Hill.  
Davis. *Elements of Meteorology*. Ginn.  
Humphreys. *Physics of the Air*. McGraw-Hill.
25. Finch and Trewartha. *Elements of Geography*. McGraw-Hill.  
Humphreys. *Physics of the Air*. McGraw-Hill.
26. Ferrel. *Popular Treatise on the Winds*. Wiley.  
Finch and Trewartha. *Elements of Geography*. McGraw-Hill.  
Milham. *Meteorology*. Macmillan.  
Humphreys. *Physics of the Air*. McGraw-Hill.
27. Finch and Trewartha. *Elements of Geography*. McGraw-Hill.  
Tyndall. *The Forms of Water*. Appleton.  
Illustrative Cloud Forms. U. S. Hydrographic Office. Wash-  
ington.  
Humphreys. *Physics of the Air*. McGraw-Hill.
28. Harrison. *Daylight, Twilight, Darkness and Time*. Silver, Bur-  
dett.  
Humphreys. *Physics of the Air*. McGraw-Hill.
29. Finch and Trewartha. *Elements of Geography*. McGraw-Hill.  
Milham. *Meteorology*. Macmillan.  
Kendrew. *Climates of the Continents*. Oxford Univ. Press.
30. Finch and Trewartha. *Elements of Geography*. McGraw-Hill.  
Ward. *Climates of the U. S.* Ginn.  
Russell. *Dry Climates of the U. S.* Univ. of California Publ. in  
Geography, Vol. 5, 1930, No. 1.
31. Shaler. *Sea and Land*. Scribner.  
Johnstone. *A Study of the Oceans*. Longmans, Green.  
Mill. *Realm of Nature*. Murray. London.  
Murray. *The Ocean*. Holt.  
Murray and Hjort. *Depths of the Ocean*. Macmillan.  
Johnson. *Shore Processes and Shoreline Development*. Wiley.

- Cornish. *Waves of the Sea, and Other Water Waves*. Univ. of Chicago Press.
- Bigelow. *Oceanography, Its Scope, Problems and Economic Importance*. Houghton Mifflin.
- Clarke. *Data of Geochemistry*. Bull. 695, U.S.G.S.
- 32.** Shaler. *Sea and Land*. Scribner.
- Croneis and Krumbein. *Down to Earth*. Univ. of Chicago Press.
- Mill. *Realm of Nature*. Murray. London.
- Murray. *The Ocean*. Holt.
- Johnstone. *A Study of the Oceans*. Longmans, Green.
- Johnson. *Shore Processes and Shoreline Development*. Wiley.
- Cornish. *Waves of the Sea and Other Water Waves*. Univ. of Chicago Press.
- Encyclopedia Britannica*. "The Tides."
- 33.** Shaler. *Sea and Land*. Scribner.
- Johnson. *Shore Processes and Shoreline Development*. Wiley.
- Davis. *The Coral Reef Problem*. Am. Geog. Soc. N. Y. Spec. Publ. No. 9, 1928.

## INDEX

- Agassiz, Lake, 124.  
Agate, 37.  
Agonic line, 542.  
Agriculture, on flood plains, 88; on mountains, 222; on plains, 174, 178, 183; and soil erosion, 56; and water table, 133.  
Air, 349; composition of, 351; conditioning of, 352; functions of, 352; height of, 349; origin of, 355; pressure of, 375; properties of, 350; saturated, 405; temperature of, 358; weathering due to, 41.  
Alkali, 148.  
Alluvial fans, 52, 66.  
Alluvial plains, 174.  
Altitude of a star, 310.  
Aluminum production, 31.  
Amazon River, 70.  
Amethyst, 37.  
Anemometer, 400.  
Angle of repose, 46, 48.  
Animals of past ages, 262, 263, 264, 265.  
Anthracite coal, 24.  
Anticline, 197.  
Anticyclone, 379, 391; velocity of, 395.  
Aphelion, 299.  
Appalachian Revolution, 276.  
Aquifer, 140.  
Archeopteryx, 280.  
Archeozoic Era, 261.  
Arctic Circle, 303.  
Arid lands, 136, 462.  
Artesian wells, 140; on coastal plains, 170.  
Asteroid, 339.  
Atlantic Coastal Plain, 521.  
Atmosphere, height of, 349; how heated, 361; origin of, 355. *See also* Air  
Atoll, 521.  
Aurora, 430.  
Ausable Chasm, 80.  
Avalanche, 46, 51.  
Bad Lands, 183.  
Bar, bay, 516; offshore, 514.  
Barograph, 379.  
Barometer, aneroid, 377; mercury, 376, 377.  
Barrier reef, 521; beach, 514.  
Basalt, 5, 6, 14.  
Base level, 65, 168.  
Batholith, 253.  
Bayou Lafourche, 103, 104.  
Beach, 490; barrier, 491, 514.  
Beryl, 36.  
Bituminous coal, 24.  
Bjerknes theory of cyclones, 393.  
Blizzard, 400, 438, 464.  
Bloodstone, 37.  
Bog, floating, 159.  
Bonneville, Lake, 159, 179.  
Bortz, 35.  
Boulder, 53; perched, 122.  
Boulder Dam, 86, 162.  
Breakers, 488.  
Breeze, land, 389; mountain, 390; sea, 389; valley, 390.  
Brontosaurus, 278.  
Building stones, 32.  
Butte, 189.  
Calcareous tufa, 147.  
Calendar, 318; Gregorian, 319; Julian, 318.  
Cambrian Period, 269.  
Canyon, Grand, 195, 262.  
Carbonados, 35.  
Carbon dioxide in air, 353, 363.  
Cascades, 82.  
Cascadian Revolution, 282.  
Caverns, 41, 146.  
Cenozoic Era, 282.  
Chalcedony, 37.  
Chalcopyrite, 31.

- Chalk, 17.  
 Chesapeake Bay, 522.  
 Chimney rocks, 490.  
 Chinook winds, 399, 463.  
 Chromosphere, 335.  
 Cirque, 114, 154.  
 Clay in soil, 54.  
 Clay products, 35.  
 Cleavage, 20.  
 Cliff, sea, 490.  
 Climate, continental, 451; dry, 446, 446; equatorial desert, 448; glacial, 453; humid continental, 464; humid subtropical, 450, 463; marine west-coast, 451; Mediterranean, 450; moist temperate, 450; monsoon savanna, 446; mountain, 452; of the Pacific coast, 461; of the past, 453, 454; polar, 453; tropical rainy, 445; tropical savanna, 445; warm, 453.  
 Climatic, controls, 442; regions, 460; zones, 443.  
 Cloud, 411; cirrus, 411, 412; cumulus, 412, 413; formation, 407, 410; nimbus, 413; stratus, 414.  
 Coal, anthracite, 24; bituminous, 24; origin of, 164; production of, 28; sedimentary, 19.  
 Coast Range, 204, 278, 282.  
 Coasts. *See* Shore lines  
 Cold wave, 465.  
 Colorado River, 86, 188, 262.  
 Columbia River, 86; lava flow, 251.  
 Columnar structure, 34, 199.  
 Comet, 340.  
 Compass, 542; earth inductor, 543; gyro-, 543.  
 Condensation, 407.  
 Conglomerate, 16.  
 Continental shelf, 7, 480; emerging of, 513.  
 Continents, origin of, 5.  
 Contours, 540.  
 Copper ores, Lake Superior, 268; production, 30.  
 Coquina, 16.  
 Coral reef, 520.  
 Cordillera, 203.  
 Corona, 335.  
 Crater, 238.  
 Crater Lake, 154, 244.  
 Creep, 47, 504.  
 Cretaceous Period, 280.  
 Crevasse, 69; in glacier, 109.  
 Currents, cause of, 500, 502; circumpolar, 505; and climate, 506; equatorial, 505; equatorward, 503; longshore, 489; monsoon, 504; ocean, 499, 501; poleward, 502.  
 Cut-bank, 90.  
 Cutoff, 90.  
 Cycle of stream erosion, 91.  
 Cyclone, 379, 391; cellar, 396; movements of, 394; origin of, 393; velocity of, 395; weather in the, 437.  
 Danube River, 70.  
 Date line, international, 317.  
 Day, civil, 316; conventional, 318; and night, 295, 301.  
 Dead reckoning, 314.  
 Delaware Bay, 522.  
 Delta, 69.  
 Dendritic drainage, 66.  
 Deposition, by glaciers, 50, 116; by ground water, 147-150; by rivers, 67; in the sea, 481; by waves, 50; by wind, 47-50.  
 Deserts, 448.  
 Devonian Period, 271.  
 Dew, 409; point, 406.  
 Diabase, 15.  
 Diamonds, 35.  
 Diastrophism, 195.  
 Dike, 252.  
 Dinosaurs, 280.  
 Diorite, 15.  
 Dipper, 311.  
 Distributaries, 69.  
 Divide, 78.  
 Doldrums, 381, 382, 388.  
 Drumlin, 118.  
 Dry farming, 49, 137, 462.  
 Dune, sand, 47.  
 Dust, in air, 355, 363; mulch, 137; storms, 49, 58.  
 Earth, 42; axis of, 294, 297; composition of, 11; curvature, 292; diameter, 291; equator, 294; in space, 290; origin of, 4; rotation, 294; the planet, 336.

- Earthquake, 228; belts, 232; cause of, 232; Charleston, 228; distribution of, 231; Ischian, 228; Messina, 231; precautions against, 234; San Francisco, 229; Tokyo, 235.
- Earthshine, 325.
- Eclipse, annular, 328; of moon, 326; partial, 328; of sun, 326.
- Ecliptic, 4.
- Emerald, 36.
- Equinox, autumnal, 302; vernal, 301.
- Eratosthenes, 291.
- Erosion, 7; by ground water, 144-147; headward, 78; interval, 258; by river, 65, 91; by waves, 489-492.
- Erratic, 117.
- Esker, 118.
- Establishment of the port, 498.
- Estuary, 92, 516, 523.
- Etna, 244.
- Evaporation, 407.
- Exfoliation, 42.
- Faceted boulder, 113.
- Faceted spur, 115.
- Fall line, 84, 171.
- Falls, 82-84; Glens, 87; Niagara, 83; Trollhätte, 85.
- Farming, dry, 49, 137, 462.
- Fathometer, 314.
- Fault, 199; scarp, 200.
- Feldspar, 14.
- Felsite, 15.
- Ferrel's Law, 387.
- Finger Lakes, 82.
- Fiord, 519.
- Fire damp, 19.
- Fissure, 199.
- Flood control, 101.
- Flood plain, 68, 87; importance of, 88.
- Floods, 99; and soil, 100.
- Foehn, 400.
- Fog, 410.
- Fold, 197.
- Fool's gold, 32.
- Forest reserves, 224.
- Formations, 260.
- Fossil, 257.
- Foucault, 294.
- Freestone, 34.
- Frost, 406, 409; action, 40, 114; killing, 468.
- Fujiyama, 239.
- Gabbro, 14.
- Ganges River, 173.
- Geanticline, 198.
- Gems, 35.
- Geological history, 257.
- Geosyncline, 198.
- Geyser, 143.
- Geysers, 149.
- Giant's Causeway, 15, 199.
- Glacial, drift, 116, 126; milk, 117; period, causes of, 120; striae, 113; till, 51, 116.
- Glaciated valley, 115.
- Glacier, 107; Alpine, 108; continental, 108; piedmont, 108; transportation by, 50; valley, 108.
- Gneiss, 22.
- Gorge, 81.
- Gradient, pressure, 380; stream, 65; temperature, 371.
- Grand Canyon, 188, 195, 207, 262.
- Grande Coulee, 86.
- Granite, 5, 6, 12, 14; production, 33.
- Graphite, 261.
- Gravel, 53.
- Great Barrier Reef, 521.
- Great Basin, 179, 181, 207.
- Great Lakes, 179, 285; origin of, 124.
- Great Salt Lake, 179, 285.
- Greenhouse effect, 363.
- Greenwich, 312.
- Groundswell, 488.
- Ground water, 131; and agriculture, 133; destructive work of, 144; deposits from, 147-149.
- Gulf Stream, 506, 507.
- Gullying, 59.
- Gypsum, 18.
- Hachures, 540.
- Hail, 415, 416.
- Halo, 423.
- Hanging valley, 82.
- Harbor, 523; artificial, 532; crater, 530; delta, 530; fiord, 530; good, 524; island, 531; lagoon, 531; New York, 526; submerged valley, 529.

- Hardness, table of, 35.  
 Hard water, 41.  
 Hawaiian Islands, 248.  
 Heat, conduction of, 360; convection of, 360; equator, 368; radiation of, 360; transfer of, 360.  
 Hematite, 18, 30.  
 Henry Mountains, 206.  
 High, a, 391.  
 History of the earth, 257.  
 Hood, Mt., 250.  
 Hornblende schist, 23.  
 Horse latitudes, 381, 382, 386, 388.  
 Hot wave, 398, 465.  
 Hudson River, 93, 124, 520, 523.  
 Humidity, 405, 471; absolute, 405; relative, 405, 408, 409.  
 Humus, 44, 53, 55.  
 Hurricane, 395.  
 Hygrometer, 408.  
  
 Ice Age, 120.  
 Iceberg, 111.  
 Ice, sheet, 416.  
 Igneous rocks, 13-16; texture, 253.  
 Insolation, 358, 366, 367; absorption by air, 367.  
 Interglacial Period, 121.  
 International date line, 317.  
 Intrusions, igneous, 252.  
 Iron ores, 18, 268.  
 Iron, production of, 30.  
 Irrigation, 134, 222.  
 Isobar, 379, 380.  
 Isogonic lines, 542.  
 Isostasy, 7, 8, 196.  
 Isotherm, 371, 466.  
 Isothermal Layer, 362.  
  
 Jade, 37.  
 Jetties, 69.  
 Joint, 199.  
 Jupiter, 337.  
 Jupiter Serapis, Temple of, 193.  
 Jura Mountains, 208-209.  
 Jurassic Period, 278.  
  
 Kame, 118.  
 Kaolin, 35.  
 Karst topography, 146.  
 Katmai, Mt., 249.  
 Kettle, 119, 155.  
  
 Knob and basin topography, 119.  
 Krakatoa, 247.  
  
 Laccolith, 252.  
 Lagoon, 156, 491, 514, 517.  
 Lake, Agassiz, 179; Algonquin, 125; artificial, 161; Bonneville, 179, 285; Champlain, 158; delta, 156; glacial, 154; Great Salt, 179; in limestone, 158; kettle, 154; Nipissing, 125; Ontario, 180; ox-bow, 155; playa, 158; Pontchartrain, 157.  
 Lakes, alkaline, 158; destruction of, 159; Finger, 126; Great, 179, 285; origin of, 153.  
 Landslide, 46.  
 Lassen Peak, 249.  
 Latitude, finding, 310, 312; parallels of, 309.  
 Lava, Columbia River, 251; surface flow, 252.  
 Lead, production, 31.  
 Levees, artificial, 69; natural, 69.  
 Light, white, dispersion of, 419, 422; refraction of, 420.  
 Lightning, 425; dangers from, 426; protection from, 428; rod, 429.  
 Light year, 333.  
 Limestone, 17; production, 33.  
 Limonite, 18.  
 Lipalian Interval, 269.  
 Loam, clay, 56.  
 Locks, 85.  
 Loess, 50.  
 Long waves, 234.  
 Longitude, finding, 313; meridians of, 309, 312.  
 Looming, 421.  
 Low, a, 391. *See* Cyclone  
  
 Magma, 15.  
 Magnetic declination, 542.  
 Magnetism, terrestrial, 542.  
 Magnetite, 30.  
 Maine, coast of, 523.  
 Mammals, age of, 282.  
 Mantle, rock, 42; transportation of, 50-51.  
 Maps, 535; contour, 540; hachure, 540; topographic, 541; weather, 392.



- Marble, 21, 24, 33.  
 Marine zones, 480.  
 Mars, 336.  
 Maturity of stream, 65.  
 Mauna Loa, 239.  
 Meander, 89, 90; entrenched, 94;  
   straightening of a, 103.  
 Mercury, 336.  
 Meridian, ante, 316; post, 316;  
   prime, 312.  
 Mesa, 189.  
 Mesozoic Era, 276.  
 Metals in the earth, 11, 29.  
 Metamorphic rocks, 19; kinds of, 22.  
 Meteors, 331, 341.  
 Mica, 14.  
 Mica schist, 23.  
 Midnight sun, 305.  
 Mineral, 12; production of, 27;  
   veins, 149.  
 Mining, 219.  
 Miocene Period, 284.  
 Mirage, 422.  
 Mississippi River, 70, 77, 101, 103,  
   166, 173.  
 Mississippian Period, 271.  
 Moisture in air, 405; condensation,  
   407; distribution, 409.  
 Monadnock, 168.  
 Monsoons, 390.  
 Moon, crescent, 324; eclipse of, 325,  
   326; full, 325; motion of, 322;  
   new, 324; phases of, 324; surface  
   of, 323; waxing and waning, 325.  
 Moraine, 111; ground, 112; kettle,  
   123; lateral, 112; terminal, 112,  
   116.  
 Mountains, and agriculture, 222; and  
   history, 215; Appalachian, 206,  
   209, 282; as barriers, 216; block,  
   200; Catskill, 206; climate of,  
   214; Coast Range, 204, 278, 282;  
   dome, 206; Elk, 206; folded, 208;  
   Henry, 206; industries in, 219;  
   Jura, 208; mature, 213; old, 213;  
   Rocky, 212, 282; Sierra Nevada,  
   204, 278, 282; synclinal, 210, 211;  
   young, 212.  
 Mountain ranges, origin of, 8.  
 Movements of earth's crust, 192.  
 Mudstone, 17.  
 Muscle Shoals, 86.  
 Nadir, 302.  
 Nares Deep, 479.  
 Natural bridge, 146.  
 Navigation, 314.  
 Nebula, spiral, 333, 344.  
 Nebular hypothesis, 341.  
 Neptune, 338.  
 Nevadian disturbance, 278.  
 Névé, 108.  
 New York Bay, 522.  
 New York Harbor, 526.  
 Niagara Falls, 83.  
 Nile River, 70, 89.  
 Nitrogen in the air, 354.  
 North Pole, celestial, 296.  
 North Star, 296, 310.  
 Norther, 400.  
 Northern lights, 430.  
 Obsidian, 16.  
 Ocean, 477; currents, 499; deeps,  
   479; origin of, 6.  
 Ohio River, 75, 99.  
 Old age of stream, 65.  
 Oligocene Period, 284.  
 Ooze, 482.  
 Opal, 37.  
 Ordovician Period, 269.  
 Ore, definition, 29; origin of, 29;  
   production of, 29-32.  
 Oxbow lake, 90.  
 Oxygen, in air, 353.  
 Ozone, 363.  
 Paleozoic Era, 269.  
 Palisade disturbance, 278.  
 Palisades, 15, 199, 252.  
 Panama Canal locks, 85.  
 Parallels, 309.  
 Passaic Falls, 82.  
 Peat, formation, 164.  
 Pegmatite, 15.  
 Pelee, Mt., 246.  
 Penepains, 167.  
 Pennsylvanian Period, 271.  
 Perihelion, 299.  
 Period, 261.  
 Permian Period, 276; salt deposits,  
   276.  
 Petrified moss, 147.  
 Petrified wood, 149.  
 Petroleum, production, 28.

- Physiographic regions, 181.  
 Physiography, 3.  
 Piedmont plateau, 172, 188.  
 Piracy, stream, 79.  
 Plain, flood, 68, 87; lacustrine, 178;  
   lake, 178, 180; outwash, 117, 178;  
   piedmont, 174.  
 Plains, Great, 180.  
 Planet, 4, 330, 338.  
 Planetesimal hypothesis, 343.  
 Planetoids, 331, 339.  
 Plateau, 187; Appalachian, 189;  
   climate of, 189; Colorado, 187;  
   dissected, 206; erosion of, 188;  
   Tibetan, 188.  
 Playa, 158.  
 Pleistocene Period, 285.  
 Pliocene Period, 285.  
 Pluto, 331, 338.  
 Polaris, 310, 313.  
 Poles, 291, 304, 309, 310.  
 Pompeii, 246.  
 Pontchartrain, Lake, 157.  
 Porphyry, 15.  
 Potholes, 84, 115.  
 Potomac River, 93.  
 Precious stones, 35.  
 Pressure belts, 382; barometric,  
   376-379.  
 Pressure gradient, 380.  
 Prevailing westerlies, 386, 387, 388,  
   435.  
 Projection, Aitoff's, 539; map, 535;  
   Mercator's, 536; Mollweide, 537.  
 Proterozoic Era, 266.  
 Psychrometer, 408.  
 Pterodactyls, 278.  
 Pumice, 241.  
  
 Quartz, 11, 37.  
 Quartzite, 20, 22.  
  
 Radiation, solar, 365.  
 Radio position finder, 314.  
 Radioactivity, 253, 254.  
 Rain, 414.  
 Rainbow, 423.  
 Rainfall, 63; map of, 447; in U. S.,  
   469.  
 Rainier, Mt., 250.  
 Rapids, 81, 84, 87, 91.  
 Red River, 179.  
 Reforestation, 104.  
 Refraction, 420-422.  
 Regelation, 108.  
 Rejuvenation of region, 92.  
 Residual mantle, 44.  
 Retarding basins, 104.  
 Revolution of earth about sun, 297.  
 Rhine River, 89, 173, 174.  
 Rhinestone, 37.  
 Rhone River, 70.  
 Rio Grande River, 77.  
 River, antecedent, 92; rejuvenated,  
   92; terraces, 94.  
 Rivers, Amazon, 70; Colorado, 65,  
   86, 188; Columbia, 86; Danube,  
   70; Delaware, 93; Ganges, 173;  
   Green, 93; Hudson, 93, 520, 523;  
   Hwang Ho, 173; Mississippi, 70,  
   77, 101, 103, 156, 173; Missouri,  
   77; Nile, 70, 89; Ohio, 75, 99;  
   Po, 173; Potomac, 93; Red, 179;  
   Rhine, 89, 173, 174; Rhone, 70;  
   Rio Grande, 77; St. Lawrence, 70;  
   Susquehanna, 70, 86, 93; Tennes-  
   see, 86; Yellow, 89.  
 Rivers, and commerce, 74; as high-  
   ways, 73; in maturity, 87; as  
   national boundaries, 77; and water  
   supply, 76; in youth, 80.  
 Roche moutonné, 113-114.  
 Rock glacier, 47.  
 Rock mantle, 42, 44; movements of,  
   46.  
 Rocking stone, 122.  
 Rocks, 12; classification of, 23;  
   igneous, 12; metamorphic, 12;  
   sedimentary, 12, 16.  
 Rocky Mountains, origin of, 282.  
 Roosevelt Dam, 135.  
 Rubies, 36.  
 Running water, 63; deposition, 66,  
   68; transportation by, 63; velocity,  
   64.  
  
 Salt, 18; lakes, 158.  
 San Andreas Rift, 230, 282.  
 San Francisco, Mt., 250.  
 Sand dune, 47.  
 Sandstone, 16; production, 34.  
 Sandy Hook, 516.  
 Sandy loam, 56.  
 Sapphire, 36.

- Sargasso sea, 508.  
 Satellite, 339.  
 Saturn, 337.  
 Savanna climate, 445.  
 Schist, 22.  
 Schistosity, 20.  
 Scoria, 241.  
 Sea, 476; basins, 478; cave, 193, 491; cliff, 490; divisions of, 477; ice in the, 483; movements of, 487; temperature of, 482; water, 480.  
 Seasons, 297.  
 Sedimentary rocks, 16; deposits, 481.  
 Seismic sea waves, 233.  
 Seismograph, 233.  
 Sextant, 312.  
 Shale, 16.  
 Shasta, Mt., 244, 251.  
 Sheet wash, 59.  
 Shore, fault-plane, 517; mountainous, 518.  
 Shore lines, 513; drowned, 517; emergent, 513; fiord, 519; irregular, 515; regular, 514.  
 Sierra Nevada Mts., 278.  
 Sill, 252.  
 Silt, 53.  
 Silurian Period, 271.  
 Simoom, 398.  
 Sinkhole, 145.  
 Sirocco, 398.  
 Sky, color of, 420.  
 Slack water, 493.  
 Slate, 20, 22; production, 34.  
 Sleet, 415.  
 Slip-off slope, 90.  
 Smudges, 364, 410.  
 Snow, 414; line, 107; in U. S., 470.  
 Soil, 52; black, 44; classification, 55; fertility, 54; mineral, 55; red color of, 55; residual, 53; sand in, 53.  
 Soil erosion, 56; causes of, 57; control of, 60; and flood control, 60.  
 Solar prominences, 335.  
 Solar system, 4, 330; size of, 331.  
 Solstice, summer, 302; winter, 302  
 Solution of rock, 63, 144-146.  
 Soo Canal, 76.  
 Sounding, echo, 314.  
 Spectrum colors, 419, 422.  
 Spillways, 103.  
 Spit, 492, 516, 517.  
 Springs, 141; fissure, 142; hot, 143; mineral, 142.  
 St. Lawrence River, 70, 124-125.  
 St. Mary's Canal, 85.  
 Stacks, 490.  
 Stalactites, 147.  
 Stalagmites, 147.  
 Standard time, 315-316.  
 Star trails, 296.  
 Steppes, 446, 449.  
 Stone quarrying, 33.  
 Storms, 391-395.  
 Strata, 17.  
 Stratification, 67.  
 Stratosphere, 358, 361.  
 Stream capture, 79.  
 Stream deposits, 68.  
 Stream, erosion, cycle, 91; effect of depression, 92; effect of elevation, 92. *See also* River  
 Streams, transportation by, 51.  
 Striae, glacial, 113.  
 Stromboli, 246.  
 Submerged coast, 516, 521.  
 Sulphur, production, 32.  
 Sun, 333; elements in, 334; heat of, 335.  
 Sunrise, 302, 304.  
 Sunset, 302, 304.  
 Sunspots, 334, 363, 365.  
 Superior, Lake, 124.  
 Surf, 488.  
 Susquehanna River, 70, 86, 93.  
 Swamps, 90, 163.  
 Syenite, 15.  
 Syncline, 197.  
 Tale schist, 23.  
 Talus, 41.  
 Tarn, 114, 154.  
 Taylor, Mt., 251.  
 Temperature gradient, 371.  
 Terrace, wave-built, 490.  
 Terracing, 223.  
 Thermograph, 364.  
 Thermometer, 364; centigrade, 365; Fahrenheit, 365.  
 Thunder, 429.  
 Thunderhead, 411.  
 Thunderstorm, 395, 396.  
 Tidal bore, 494.  
 Tidal disruption theory, 345.

- Tidal races, 493.  
 Tides, cause of, 495; ebb, 493; effects of, 499; flood, 493; neap, 498; range of, 493; in rivers, 494; running of, 493; solar and lunar, 498; spring, 498.  
 Till, glacial, 116.  
 Till plains, 176.  
 Time, daylight-saving, 315; geologic, 258; local, 314; solar, 315; standard, 315; sun, 314.  
 Topaz, 36.  
 Topography, karst, 146.  
 Tornado, 395, 396, 397.  
 Tourmaline, 36.  
 Trap, 15.  
 Travertine, 147.  
 Tremor, primary, 234; secondary, 234.  
 Triassic Period, 276.  
 Trilobite, 269, 270.  
 Tropic of Cancer, 303.  
 Tropic of Capricorn, 303.  
 Tropics, 434.  
 Troposphere, 362.  
 Tsunami, 233.  
 Turquoise, 37.  
 Typhoon, 395.  
  
 Ultraviolet rays, 367.  
 Unconformity, 259.  
 Undertow, 488.  
 Uranus, 338.  
  
 Vadose water, 131.  
 Valley, glacier, 108, 519; hanging, 116; river, 78; train, 117; U-shaped, 115; V-shaped, 91.  
 Varves, 117, 259.  
 Veins of mineral, 149.  
 Velocity of river, 67, 68.  
 Venus, 336.  
 Vesuvius, 240; eruption of, 245.  
 Volcanic cones, 205; life history of, 242; young, 243.  
 Volcanoes, 238, 266; active, 249; craters of, 238; distribution of, 242; explosive, 238; extinct, 250; Hawaiian, 205; origin of, 253; quiet, 238.  
 Warp, broad, 198.  
 Watchung surface flow, 252.  
 Water, hard, 145.  
 Waterfalls, 82; recession of, 84.  
 Water gap, 93.  
 Water power, 85, 220.  
 Water table, 131; perched, 133.  
 Water vapor in air, 354.  
 Wave-built terrace, 490.  
 Wave-cut bench, 490.  
 Wave erosion, 489.  
 Waves, 487; pounding of, 488; seismic, 233.  
 Weather, 433; in the anticyclone, 438; in the cyclone, 437; in the tropics, 434; maps, 392, 440; outside the tropics, 435; prediction, 436, 441; signs and proverbs, 441.  
 Weather Bureau, 440.  
 Weathering, 40; chemical, 40; exfoliation, 42; frost action, 40; gravity, 46; mechanical, 40; oxygen, 41; plants and animals, 43; temperature, 42; water, 41; wind, 47.  
 Wells, 137; artesian, 140; construction, 139; location, 138.  
 Whetstone, 34.  
 Wilson Dam, 105.  
 Wind abrasion, 47.  
 Wind belts, 387; shifting of, 389.  
 Wind erosion, 47.  
 Wind gap, 93.  
 Winds, 384-401, 471; cause of, 384; continental, 390; cyclonic, 391, 395; deflection of, 385; monsoon, 390; shifting of, 398, 399; special, 399; velocity, 400.  
 Youth of stream, 65.  
 Zenith, 302.  
 Zones, climatic, 443, 444.





