

630.7

I 2 6b

no.555

cop.8



UNIVERSITY OF  
ILLINOIS LIBRARY  
AT URBANA-CHAMPAIGN  
~~BOOKSTACKS~~



630.7  
IL66  
no. 555  
cop. 8

C8

# ELECTRICAL CONTROL SYSTEM

for

## Automatic Feed Grinding

CIRCULATING COPY  
AGRICULTURE LIBRARY



AGRICULTURE LIBRARY

SEP 26 1990

Bulletin 555 UNIVERSITY OF ILLINOIS  
UNIVERSITY OF ILLINOIS  
AGRICULTURAL EXPERIMENT STATION

## FOREWORD

The electrical control unit described here was originated as part of a design for an automatic feed handling, mixing, and grinding installation. With suitable modification, the unit can be used for automatic and safety controls on other farm electrical equipment. This report is concerned only with the control unit and does not attempt to discuss conditions of the installation with which it will be used.

This unit was developed as a phase of a larger research study, "The Application of Electricity to Farm Operations," a cooperative project between the Illinois Station and the U. S. Department of Agriculture. It is an example of a development that should be reported at once instead of waiting for the completion of the entire study. Project leaders are E. W. Lehmann, R. W. Mowery, M. W. Forth, and G. F. Sauer of the Illinois Station, and L. S. Foote of the Bureau of Plant Industry, Soils, and Agricultural Engineering of the U. S. Department of Agriculture. A substantial part of the financial support is from trust funds provided by the Public Service Company of Northern Illinois.

With this publication the control system is released for unrestricted use.

*Cover photograph shows the control box. All operations necessary for automatic grinding are controlled by the push buttons, timer dial, and switches shown on the face of the box.*

# ELECTRICAL CONTROL SYSTEM

## For Automatic Feed Grinding

By R. W. MOWERY, First Assistant in Agricultural Engineering

**T**HE ELECTRICAL UNIT described in this bulletin was designed to control automatically the operation of equipment used in a farm feed-grinding installation.<sup>1</sup> The general problem was to combine ear corn, oats, and other ingredients of feed, regulate their flow uniformly to a grinder, remove the ground feed, and deliver it to storage bins, wagons, or animal feeders.

The principal item of the installation was a 5-horsepower grinder. A conveyor system removed the separate ingredients in the desired proportions from crib, bins, or containers, and the combined materials were then fed into the grinder. In some experimental installations, an auxiliary blower removed the ground feed from the grinder to a storage bin, but such a blower is a device which may or may not be included in a farm installation. (This auxiliary blower is not the same as the blower which is an integral part of a hammermill.)

### The design problem

The design of the electrical control system was based on the following requirements, conditions, and limitations:

1. Grinding had to be fully automatic so that an attendant was not required except to start the operation.
2. Machines were to shut off either after a predetermined length of grinding period or after a certain amount of feed had been ground.
3. Individual protection had to be provided for both the motors and the solenoids which operated the clutches in the conveyor system. Devices necessary for this purpose should be

<sup>1</sup>Forth, M. W., Mowery, R. W., and Foote, L. S. Automatic feed grinding and handling. *Agricultural Engineering* 32, 601-605. November, 1951.



arranged so the operator can select the ingredients of the feeding ration by means of switches on the control box.

4. Operations were to stop automatically under any one of the following conditions: (a) line voltage dropped below a safe value; (b) dangerous overloading was imminent on the blower, grinder, or conveyor motors; (c) the drive between the grinder and its motor failed; or (d) the supply of any one of the feed ingredients failed because of clogging, arching, or being used up.

5. It was advisable to avoid starting two or more motors at the same time because of the heavy initial current requirement.

6. For economy and efficiency, it was desirable that the grinder operate at or near its full capacity. This presented a major difficulty because in a typical feeding ration ingredients range in size from fine materials to oats and shelled corn and ear



Equipment used in automatic feed grinding consists primarily of a grinder, a system of conveyors, and usually a blower to handle the ground feed. (Fig. 1)



corn. An excess of the smaller particles or sometimes a single ear of corn fed into the grinder creates a momentary overload on the motor. When this happens, it is necessary that the conveyor system stop until the overload is relieved and then start again to keep the grinder going at near capacity.

7. The design called for optional inclusion of blower control. A blower is not always a part of the installation, but when it is included it has to be controlled.

8. The prescribed sequence of operations was as follows: (a) Set timer or other control device to fix either the length of time machines are to operate or the amount of feed to be ground. (b) Press "start" button to begin automatic grinding. (c) Blower to start first in order to clear the delivery pipes and remove moisture that may have condensed inside. (d) Grinder to start 15 to 30 seconds later. (e) Conveyors to start after grinder reaches operating speed. (f) Conveyors to stop with each brief overload on the grinder motor and then to start automatically in order to maintain grinder capacity.

9. At the end of the operating period, the conveyors were to stop first to allow the grinder to empty, and the blower was to run until the last of the feed was delivered to storage.

10. The electrical control devices were to be assembled in a compact unit, enclosed in a single safe dust-tight box, and designed as a complete electrical system.

How these requirements were met is explained in the rest of this report, which deals with the design and assembly of the unit and defines the type and use of each element.

## **Design of the primary operating control**

The principal problem was to devise an on-off control for the conveyors so as to supply feeds to the grinder at near maximum capacity and yet permit only brief overloads caused by ears of corn or quantities of small grain. This required that the conveyor controls be actuated by the grinder motor.

Among the several characteristics of a single-phase motor that reflect the load upon it, the *input current* appeared to be

the most feasible for obtaining the desired control. Input current varies almost directly with motor load within the range of half load to 150 percent of full load. Also its use permits a relatively simple low-cost control, desirable for a farm installation. For these reasons, the on-off control of the conveyor was provided by a current-sensitive solenoid relay, essentially an overload relay. It was connected in such a way that the current to the grinder motor flowed through the coil of the solenoid while the motor was running. When the current reached a prescribed value (because of brief overloading), the plunger inside the solenoid coil rose to open the circuit and stop the conveyor. When the current to the motor decreased (that is, the overload condition was relieved), the solenoid plunger dropped and the conveyor started. This on-off cycle continued throughout the grinding period.

Ideally the conveyor should operate at a continuously variable speed, conforming in indirect ratio to the load on the grinder motor. The possibility of achieving this condition was rejected both because of cost and complexity and because of the abrupt changes in loads.

Other factors besides input current vary either directly or indirectly with the motor load when voltage is constant. Among those considered, but rejected because of cost, complexity, or difficulty of application were: power factor, power input, torque, and speed change with load.

### **Underload stop control**

In addition to the on-off control of the conveyors, it was also necessary to provide controls to stop operations (1) when the interval timer indicated the end of the grinding period, (2) when the supply of any of the feed ingredients failed, or (3) if the drive between motor and grinder failed. These requirements were met by the use of a motor-driven time-delay relay. This relay operated normally as long as the conveyors were cycled by the overload (solenoid) relay. But when either the interval timer stopped or the grinder motor was underloaded for a fixed delay period, the relay stopped the grinder.

## Blower control

A manually operated transfer switch of the double-pole, double-throw type was provided so that the blower-motor circuit might be made a part of the automatic control system, or cut off entirely. With the switch on, a time-delay relay in the circuit delayed the start of the grinder motor for 15 to 30 seconds after the blower motor had started. A thermal relay was used because of its relatively low cost. It does not have to reset itself quickly and functions only once each time the grinder is used.

## Control unit

The simplicity of the unit in use is indicated by the photograph of the control box on the front cover. The switching levers and buttons on the face of the box permit "push-button" operation. Switches, relays, timer, and other devices are assembled and fully enclosed for protection from dust, moisture, and damage. Power is obtained simply by plugging the cable into a 3-wire 110-220 volt a-c line. Receptacles on the side of the control box provide a convenient means for making connections to the control system.

## Parts of the control unit

The parts that make up the complete electrical control unit are illustrated in Figs. 2, 3, 4, and 5. Parts can be identified by the following key.

**A, B. Magnetic starting switches.** **A** starts grinder automatically, **B** starts blower. These are standard switches which have both undervoltage and overload protection.

**C. Magnetic contactor.** Actuated by the solenoid (overload) relay to open and close circuit to the conveyor mechanism.

**D. Overload relay.** The basic control device for the conveyor system. It is wired into a normally closed circuit in such a way that it breaks the circuit to the magnetic contactor (C) when the grinder motor is overloaded.

**E. Interval timer.** Is set manually to fix the length of grinding time each time the grinder is started. It closes the circuit

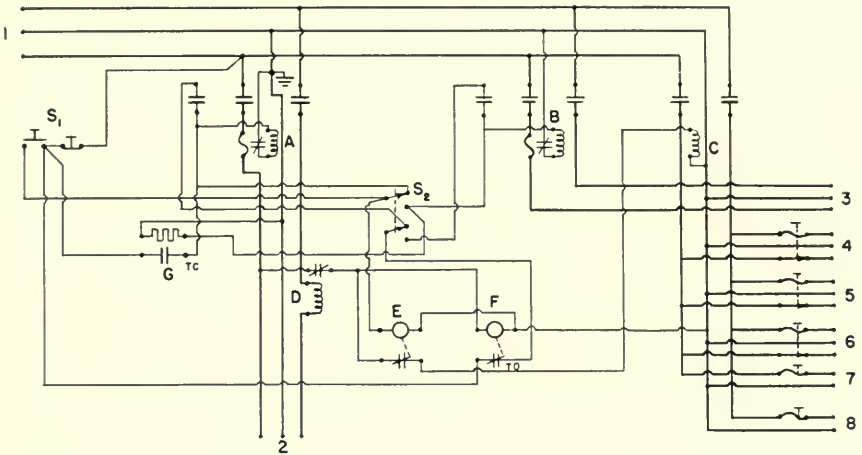

Diagram of the electrical control unit. For identification of the parts, see the accompanying text. (Fig. 2)

between the overload relay and the magnetic contactor until the period is ended. (When a device for determining the amount of feed to be ground, such as a vane switch or scale switch, is used, it can be connected at this point in the circuit.)

**F. Motor-driven time-delay relay.** Instantaneous-resetting type which starts anew each time the conveyors stop because of an overload of the grinder motor. Its time-delay interval is such that it will not break the circuit in normal operation. It will, however, stop the grinder motor either when the interval timer stops or when the grinder motor is underloaded for a fixed delay period.

**G. Thermal time-delay relay.** Provides for an interval between the starting of the blower motor and of the grinder motor.

**$S_1$ . Push-button station.** To start the automatic operation or to stop all machines at once in an emergency.

**$S_2$ . Transfer switch.** A double-pole, double-throw toggle switch to include the blower or to cut it out of the system. If the blower is not included, the thermal relay does not operate and the push-button control is transferred to the grinder-motor starting switch.

**1. Connection to power supply.**

**2, 3, 4. Outlets for grinder, blower, and crib-conveyor motors respectively.**

**5. Outlet for bin-conveyor motor** (not necessary for grinding ear corn only).

**6. Outlet for solenoid** which operates the clutch on the feed-in to the grinder.

**7, 8. Outlets for solenoids** which operate clutches on individual bin-conveyor devices (not necessary for grinding ear corn only).

## Operation

Manual operations at the start of automatic grinding include setting the interval timer, throwing the transfer switch accord-

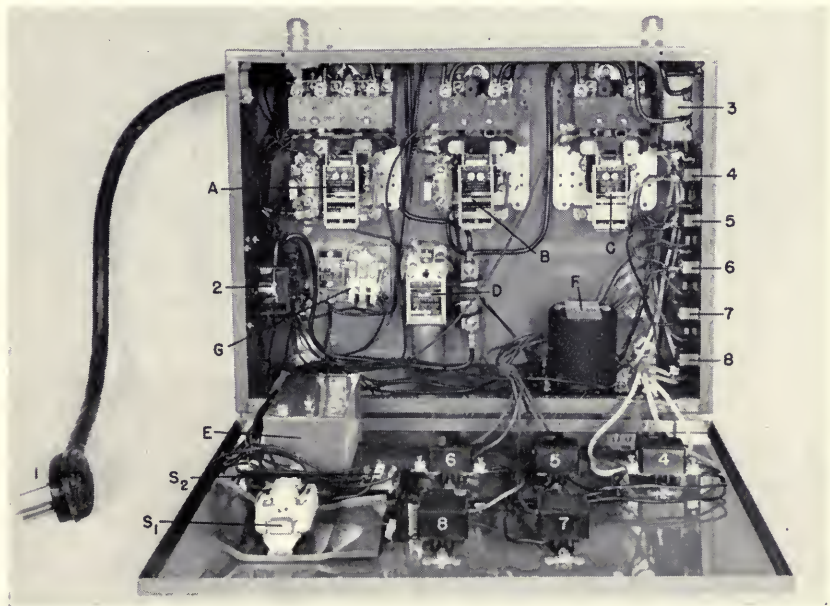

The complete control unit made according to the diagram in Fig. 2. See text for identification of parts. (Fig. 3)



ing to whether or not the blower is to be used, and turning on the switches controlling the crib- and bin-conveyor motors depending upon the feeding ration desired.

At this stage, the conveyor-overload relay circuit is closed, since it will be actuated only when the grinder motor is operating. The other circuits—to motor-starting switches, time-delay relays, and magnetic contactor—are open; each will be closed automatically and in proper order after the equipment is set in operation. The attendant then sets the sequence in motion by pressing the “start” button.

### Control unit without blower

The design of this electrical control unit is based on the assumption that a blower will be a part of the automatic system.

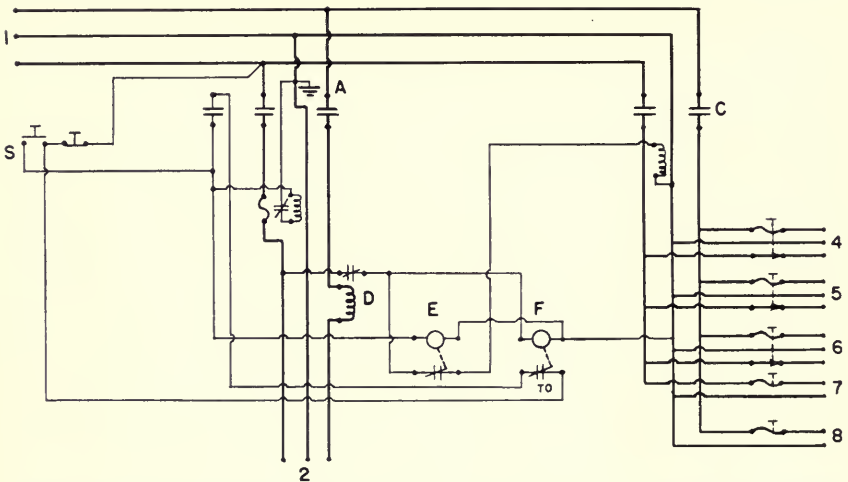

Modification of the control system pictured in Fig. 2, without the blower motor switches and controls. (Fig. 4)

Thus the complete unit includes the starting switch for the blower motor, the thermal time-delay relay, and the outlet for connecting the motor. The transfer switch provides for optional operation of the blower.

In an installation without a blower, these parts may be omitted or they may be added later within the same control box. The unit without the blower circuit is shown in Figs. 4 and 5.

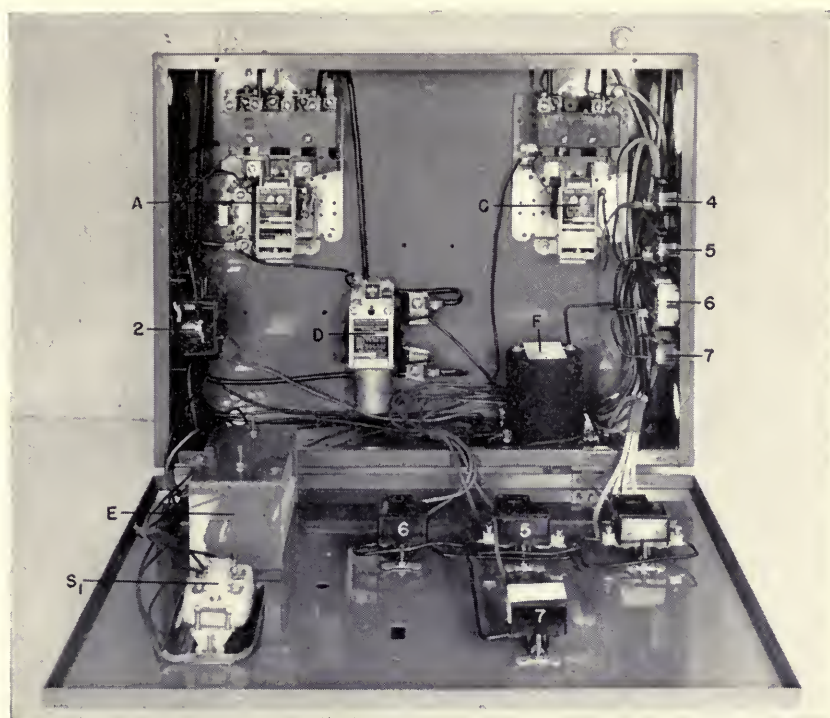

Control box without the blower-motor sockets and controls. These could be added by a modification of the wiring. (Fig. 5)











UNIVERSITY OF ILLINOIS-URBANA



3 0112 018395878