





green

THE ELECTRIC FURNACE

ITS EVOLUTION, THEORY AND
PRACTICE

BY

ALFRED STANSFIELD, D.Sc.

ASSOCIATE OF THE ROYAL SCHOOL OF MINES
PROFESSOR OF METALLURGY IN MCGILL UNIVERSITY
MONTREAL

WITH FIFTY-THREE ILLUSTRATIONS



THE CANADIAN ENGINEER
TORONTO

HILL PUBLISHING COMPANY

NEW YORK AND LONDON

1907

TK-4601
CS

GENERAL

Entered according to Act of the Parliament of Canada, in the year one thousand nine hundred and eight, by ALFRED STANSFIELD, D.Sc., at the Department of Agriculture.

P R E F A C E .

On my first visit to Canada, in 1897, I constructed an electric furnace and showed it in operation at a lecture on Canada's metals, which was delivered by the late Sir William Roberts-Austen. The application of electrical heat to Metallurgy has always interested me greatly and I hope that this little book may serve to instil this interest in others, and to help forward the application of electric smelting in a country which is so rich in water-powers and mineral resources.

This book originated in a series of papers, written about a year ago for the "Canadian Engineer," in which I endeavoured to present, as simply as possible, the principles on which the construction and use of the electric furnace depend, and to give an account of its history and present development.

The original papers were written at a time when the experiments of Dr. Haanel, at Sault Ste. Marie, were attracting public attention, and a large section of the book has been devoted to the consideration of these and other advances in the electro-metallurgy of iron and steel.

I wish to thank all who have helped me in the preparation of this book, including Dr. Haanel, whose valuable monographs have formed the basis of my chapter on iron and steel, and to whom I am indebted for additional information on this branch of the subject: Prof. J. W. Richards, who has taken an interest in my work, and whose book on "Metallurgical Calculations" has been of considerable assistance in writing the chapter on furnace efficiencies; Mr. E. A. Colby, who gave me information in regard to his induction steel furnace and a sketch for Fig. 25; Mr. Francis A. J. Fitzgerald, who supplied me with the data for Table X.; the editor of the "Electrochemical and Metallurgical Industry," who loaned the block for the frontispiece, and the International Acheson Graphite Company, who gave me information about their furnaces and lent the block for Fig. 40. I also wish to thank those of my personal friends who assisted me in the tedious work of proof-reading.

ALFRED STANSFIELD.

November, 1907.
McGill University, Montreal,



CONTENTS.

CHAPTER I.

History of the Electric Furnace.

	Page.
The electric arc	1
W. Siemens' electric furnaces	3
Cowles brothers' electric furnaces	5
Hall and Heroult aluminium processes	6
H. Moissan's researches	7
Production of the diamond	9
Willson's carbide furnace	9
Carborundum	10
Ferro-alloys	12
Iron and steel	12

CHAPTER II.

Description and Classification of Electric Furnaces.

Definition of electric furnace	15
Heat produced by electric current	16
Essential parts of electric furnace	17
Classification of electric furnaces'	18
Arc furnaces	19
Resistance furnaces	21
with special resistor	21
without special resistor	26
electrolytic	30

CHAPTER III.

Efficiency of Electric and other Furnaces, and Relative Cost of Electrical and Fuel Heat.

	Page.
Cost of electrical energy	33
Efficiency of furnaces	34
Calculation of furnace efficiencies	37
Heat units	38
Melting temperatures of metals, and amounts of heat required to melt them	40
Calorific power of fuel	41
Table of calorific powers	43
Calculation of efficiency of electric steel furnace	45

CHAPTER IV.

Electric Furnace Design, Construction and Operation.

General considerations	48
Materials of furnace construction	49
Fireclay bricks	49
Silica bricks	50
Lime	50
Magnesia	51
Dolomite	52
Alumina	52
Carbon	53
Carborundum	54
Siloxicon	54
Table of refractory materials	55
Heat insulation	50
Table of heat conductivities	57
Furnace walls without refractory materials	58
Production of heat in electric furnaces	60
Voltage required for electric furnaces	66
Voltage of arc furnaces	67
Voltage of resistance furnaces	69
Regulation of electric smelting	71
Resistors	73
Electrical resistivity	75
Resistivity of powdered coke	75
Resistivity of carbon rods	76
Resistivity of molten slags and iron	78
Electrodes.	79
Electrode holders	80
Measurement of furnace temperatures	82
Conclusion	83

CHAPTER V.

Production of Iron and Steel in the Electric Furnace.

Varieties of Iron and Steel	85
I. Production of steel from scrap, pig-iron and iron ore.....	86
Heroult steel furnace	86
Keller steel furnace	92
Kjellin steel furnace	93
Colby steel furnace	96
Gronwall steel furnace	101
Gin steel furnace	105
Girod steel furnace	106
II. Production of pig-iron from iron ore, carbon and fluxes....	107
Heroult ore-smelting furnace	108
Keller ore-smelting furnace	111
Harmet ore-smelting furnace	113
Haanel-Heroult furnace	115
Turnbull-Heroult furnace	117
Plants for the electric smelting of iron ores	120
Possibilities in the electric smelting of iron ores.....	121
III. Direct production of steel from iron ore	120
Stassano steel furnace	120
Elimination of sulphur and phosphorus	132
Conclusion	135

CHAPTER VI.

Other Uses of the Electric Furnace.

I. The ferro-alloys	136
Analyses of ferro-alloys	139
II. Graphite and the carbides	142
Graphite	142
Kryptol	149
Carborundum	149
Siloxicon	153
Calcium carbide	154
III. Electrothermic production of zinc	155
Cowles zinc furnace	157
Johnson zinc furnace	157
Laval zinc furnace	159
Salgues zinc furnace	160
Conditions for obtaining liquid zinc	162
Experimental zinc furnace	164
Snyder zinc process	165
Snyder zinc furnaces	167
Electrical energy required for zinc smelting	170
IV. Miscellaneous uses of the electric furnace	171
Silicon	171
Fused quartz	172
Glass	172
Alundum	173
Nitric acid	173
Phosphorus	174
Carbon bisulphide	174
V. Electrolytic processes	174
Electrolysis	174
Acker caustic soda process	177
Castner sodium process	179
Ashcroft sodium process	181
Swinburne and Ashcroft chlorine-smelting process	184
Aluminium	185

CHAPTER VII.

Future Developments of the Electric Furnace.

General considerations	189
Exhaustion of coal supplies	190
Utilization of water-powers	191
Achievements of the electric furnace	191
Probable uses of the electric furnace in the future	192
Other sources of electric power	194

Index	195
--------------------	-----

LIST OF ILLUSTRATIONS.

Fig.	Frontispiece: Colby Induction Steel Furnace.	Page.
1.	Electric arc	1
2.	Siemens' vertical arc furnace	4
3.	Siemens' horizontal arc furnace	5
4.	Cowles furnace for aluminium alloys	6
5.	Aluminium furnace	7
6.	Moissan furnace	8
7.	Willson carbide furnace	10
8.	Acheson carborundum furnace	11
9.	Electric circuit	15
10.	Independent arc furnace	19
11.	Direct-heating arc furnace	20
12.	Electrical tube furnace	21
13.	Electric crucible furnace	22
14.	Borchers' resistance furnace	24
15.	Tone resistance furnace	25
16.	Shaft furnace with lateral electrodes	27
17.	Shaft furnace with central electrodes	28
18.	De Laval ore-smelting furnace	29
19.	Electrolytic furnace	30
20.	Losses of heat in melting metals	35
21.	Ideal electric furnace	48
22.	Electrode Holder of Heroult Steel Furnace	81
23.	Heroult steel furnace	87
24.	Kjellin Steel furnace	93
25.	Colby induction furnace	97
26.	8-ton induction steel furnace	100
27.	Induction furnace with shielded core	103
28.	Gin steel furnace	104
29.	Heroult ore-smelting furnace	108
30.	Keller furnace	112
31.	Harmet furnace	114
32.	Haanel-Heroult furnace	116
33.	Turnbull-Heroult furnace	118
34.	and 35. Connections for electric furnace	119
36.	Ideal furnace (for smelting iron ores)	122
37.	Stassano furnace	130
38.	Acheson graphite furnace	145
39.	Acheson electrode furnace	145
40.	Carborundum furnace burning	151
41.	Multiple core furnace	154
42.	Cowles electric zinc furnace	157
43.	Johnson electric zinc furnace	158
44.	Laval electric zinc furnace	159
45.	Salgues electric zinc furnace	160
46.	Experimental zinc furnace	163
47.	Snyder induction furnace	166
48.	Snyder furnace for obtaining liquid zinc	168
49.	Acker caustic soda furnace	178
50.	Castner sodium furnace	180
51.	Ashcroft sodium furnace	182
52.	Aluminium furnace	186

LIST OF TABLES.

Table.		Page.
I.	Classification of electric furnaces	32
II.	Net efficiencies of furnaces used for melting metals	34
III.	Melting temperatures of metals, and amounts of heat required to melt them	40
IV.	Calorific powers	43
V.	Refractory materials	55
VI.	Heat conductivities of furnace materials	57
VII.	Voltage of Moissan's arc furnace	68
VIII.	Resistivity of graphitized coke powder	76
IX.	Resistivity of solid carbon	77
X.	Resistivity of amorphous and graphitic carbon	78
XI.	Operation of 5-ton Heroult furnace	89
XII.	Induction furnaces in operation or in course of construc- tion	99
XIII.	Steel and slag analyses	134
XIV.	Analyses of ferro-alloys	139 & 140

INTRODUCTION.

The rapid growth of the electric furnace makes it increasingly difficult for the metallurgist to keep in touch with its recent developments. A few years ago it was a scientific curiosity; now it threatens to rival the Bessemer converter, the open-hearth steel furnace, and even the blast furnace itself.

The halo of romance, that has always surrounded electricity in all its forms, has caused the wildest schemes to be originated, and has given them a hearing; while, on the other hand, practicable electric smelting processes have been considered visionary.

In this book, it has been the author's purpose to trace the evolution of the electric furnace from its simplest beginnings, and to set forth, as briefly as is consistent with clearness, the more important facts relating to its theory and practice.

No attempt has been made to give a description of all the electric furnaces that have been invented, but rather to set forth clearly the fundamental principles of this form of furnace; to show its various uses; to indicate its limitations; and, if possible, to be of some assistance to those who wish to design electric furnaces, or to judge of the feasibility of schemes involving their use.

The scope of the book can be gathered from the titles of the seven chapters of which it is composed. The first is historical, the next three relate to the classification, efficiency and design of electric furnaces, while Chapters V. and VI. are devoted to the manufacture of iron and steel, and other products of the electric furnace. Chapter VII. is an attempt to look into the future and to note the directions in which electrical heating may be expected to develop.



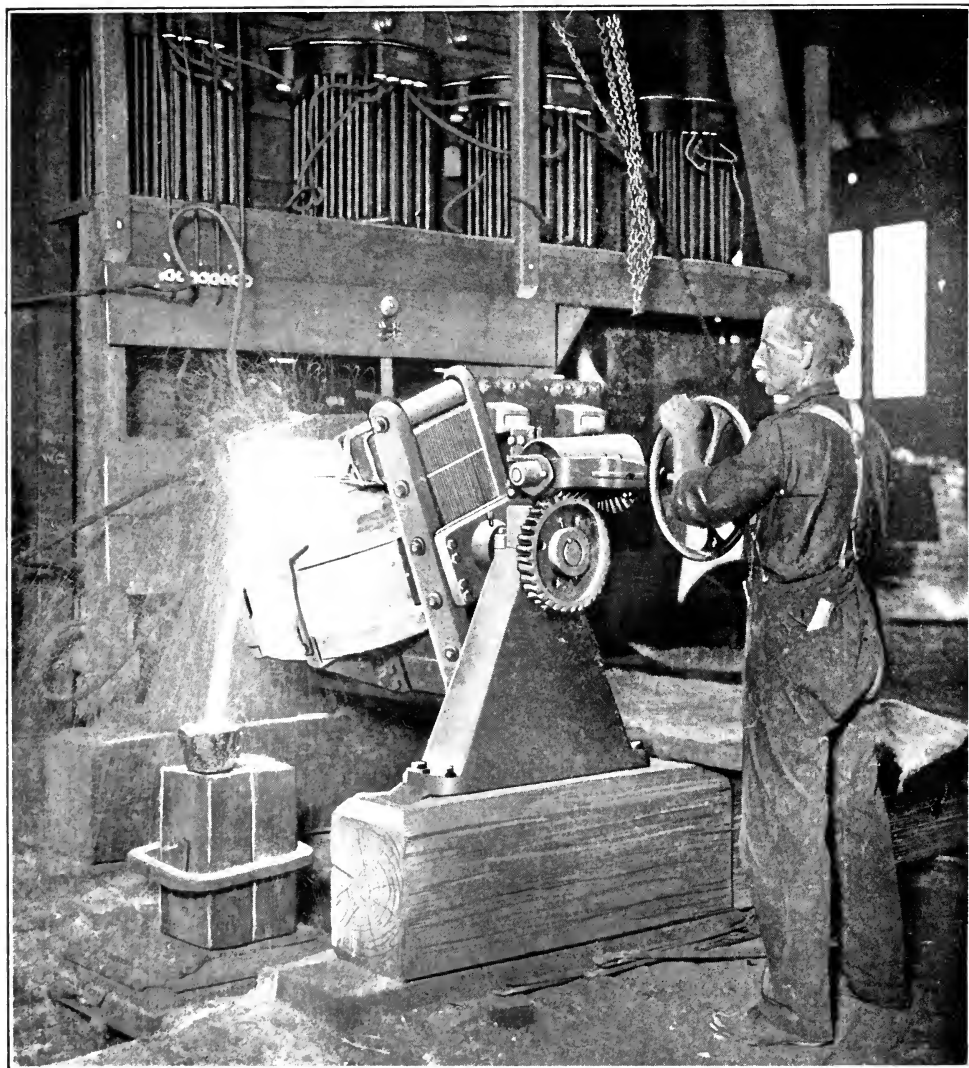

COLBY ELECTRIC STEEL FURNACE

OF
CALIFORNIA

THE ELECTRIC FURNACE.

Its Evolution, Theory and Practice.

CHAPTER I.

History of the Electric Furnace.

The electric furnace is of comparatively recent origin. The first of any practical importance, was constructed by Sir W. Siemens in 1878*, and in 1882† he melted in an electric furnace

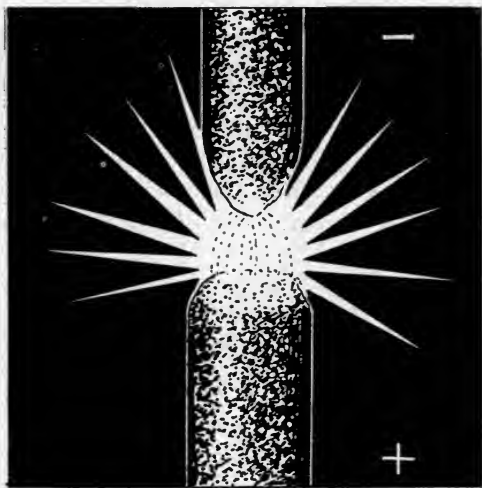

Fig. 1.—The Electric Arc.

some twenty pounds of steel and eight pounds of platinum. Since that time the development has been rapid.

The beginning of the electric furnace may, however, be traced much farther back than this. In 1800—only a few months after Volta's discovery of the electric battery—Sir Humphry Davy, experimenting with the new battery, produced the first arc light between carbon points,‡ and, as the electric arc is the source of heat in an important class of electric furnaces, its discovery was the first step in their evolution.

*Siemens' Electric Furnace, Journ. Soc. of Telegraph Engineers, June, 1880.

†Siemens and Huntingdon, British Assoc. for the Adv. of Science, 1882, p. 496.

‡Davy, S. P. Thompson's Electricity and Magnetism, Phil. Trans. Roy Soc., vol. xcvii. (1809), p. 71, and vol. cxi. (1821), p. 427.

The electric arc, as shown in Fig. 1, may be produced by passing an electric current through two carbon rods which touch each other and then drawing them apart. The arc consists of a flame of vaporized carbon, extending from one carbon pole to the other. When an electric current meets with resistance, it is transformed into heat, and, as the carbonaceous vapour offers a considerable resistance to the electric current, a very high temperature is produced; high enough to melt or vaporize any known substance.

In the direct current arc the positive carbon, which is marked + in the figure, is hollowed out by the current, and becomes intensely white hot, presenting the dazzling bright light with which all are acquainted. The arc light is, in fact, a miniature electric furnace of the arc type; and produces a temperature not much inferior to that in any modern electric furnace. It has been supposed that the hollowing out of the positive carbon is due to an electrolytic conveyance of carbon from the positive to the negative electrode; but recent experiments show that any electrical transfer of carbon is in the other direction, being a stream of electrons from the negative electrode, like the cathode discharge in a vacuum tube. The bombardment of the positive carbon by this stream of electrons, generates so much heat that the electrode becomes white hot and rapidly evaporates, thus producing the characteristic crater-like form.

This explanation appears to fit in well with the appearance of an arc that has been drawn out to a little more than its normal length. The arc (which should only be observed through a dark-colored glass screen) will be noticed to stream freely from the tip of the negative electrode, and its starting-point on this electrode is unaffected by drafts or magnetic influences. The current passes with difficulty on to the positive electrode, and does not always select the point nearest to the negative electrode, but is blown about and wanders over a considerable area of the electrode. The temperature of the hottest part of the positive carbon in the electric arc has been measured, and is considered to be about $3,700^{\circ}\text{C}$. ($6,700^{\circ}\text{F}$.), which is twice the temperature of melting platinum or melting quartz, and more than twice the temperature of the open-hearth steel furnace.

In the use of a direct current arc for lighting, it is usual to make the upper carbon the positive electrode, in order to throw the greatest illumination downwards. In Fig. 1 this arrangement has been reversed, and in this position the positive carbon serves

as a miniature cup in which any substance can be placed in order to study its behavior at these high temperatures.

The writer has placed a small cylinder of refractory material around the lower carbon of such an arc, and, with this simple apparatus, was able to repeat some of Moissan's well-known experiments on the production of the diamond.

In another form of electric furnace, the heat is produced by the passage of the electric current through a solid or liquid conductor. This method of producing electrical heat is typified in the common incandescent lamp. The earliest use of this method of heating was in 1815, when W. H. Pepys* solved an important question in regard to the nature of steel by means of a miniature resistance furnace operated by a battery. He placed some diamond dust (a pure form of carbon) in a cut in a piece of wrought iron wire, and passed an electric current through the wire, thus heating it to redness. The iron absorbed the diamond dust and became converted into steel.

Although the principle of electric heating had thus been discovered early in the century, very little progress was made with the practical application of this source of heat until the discovery of the dynamo. Among those who attempted to utilize electrical heat in small furnaces, with the aid only of powerful electric batteries, may be mentioned—Napier, who, in 1845, produced a small arc in a plumbago crucible, intending to reduce certain metals from their ores; Despretz†, who, in 1849, made a small tube of charcoal, about an inch long, and heated it by passing through it an electric current from a battery of 600 Bunsen cells; and Pichou,‡ who described, in 1853, a furnace, heated by a series of electric arcs. The furnace, which was probably never constructed, was intended for the reduction of metallic ores. Joule and Thompson also attempted to utilize the high temperature of the electric arc.

Until the invention of the dynamo, in 1867, experiments requiring any considerable amount of electrical power could only be conducted at great trouble and expense by means of electric batteries. Sir W. Siemens, with the aid of the dynamo, began, in 1878, to experiment on the electric furnace, which he used mainly for melting metals. The form of furnace usually associated

*Phil. Trans. Roy. Soc., 1815, vol. cv., p. 371.

†Despretz, *Comptes Rendus de l'Acad. des Sciences*, vol. xxviii., p. 755, and vol. xxix., pp. 48, 545, 712, (1849).

‡Mentioned by Andreoli, *Industries*, 1893, see Borchers' *Electric Smelting*.

with his name* is shown in Fig. 2, and consists of a crucible A of graphite or similar refractory material, and of two rods, B and C, for leading in the current. The lower rod was made of metal, and fitted into the base of the crucible, while the upper was of carbon, and was actuated by an automatic regulating device to maintain the arc E of a constant length. The metal to be melted was placed in the crucible, making electrical contact with the lower pole C; then the rod B was lowered until an arc was started between this rod and the metal in the crucible.

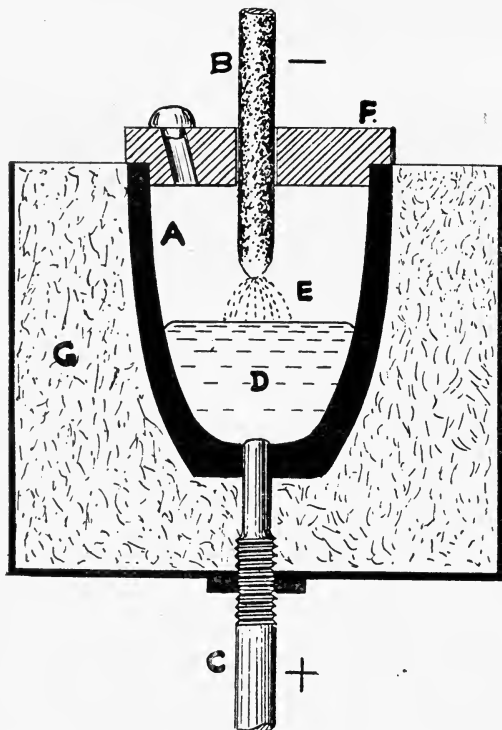

Fig. 2.—Siemens' Vertical Arc Furnace.

In the illustration the metal is shown melted, at D, as it would be at the end of the operation.

The positive pole is always hotter than the negative pole, and for this reason the metal to be melted is made the positive pole of the arc. A lid, F, was provided with a hole for observing the operation, or making additions to the charge, and a protecting

*W. Siemens' English patent, 2,110, 1879, see Borchers' Electric Smelting.

covering, G, was arranged to reduce as far as possible the radiation of heat from the crucible.

In this furnace he was not only able to melt several pounds of steel and platinum, but even to vaporize copper which had been packed with carbon in the crucible.*

Siemens also invented a furnace having horizontal electrodes, as shown in Fig 3.† In this furnace the arc passes between the two electrodes B and C, and heats, by radiation, the material contained in the crucible. In both furnaces he provided water-cooled copper electrodes for the negative pole of the arc, to avoid the wasting that takes place when carbon electrodes are used. In Fig. 3, the negative electrode, C, consists of a copper tube, closed at one end, and cooled by water, which is introduced by a smaller

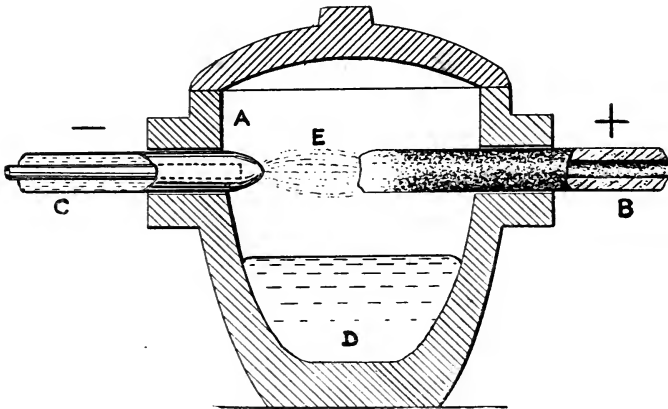

Fig. 3.—Siemens' Horizontal Arc Furnace.

pipe inside it. The positive electrode, B, is a hollow carbon rod, and through it a neutral or reducing gas, can be introduced into the furnace.

In 1883, Faure patented an electric furnace of the resistance type, the heat being generated by the passage of the current through solid conducting rods imbedded in the hearth of the furnace, on the same principle as the electric cooking stove.

The resistance type of electric furnace was made a commercial success by the brothers, E. H. and A. H. Cowles, whose

*Siemens and Huntingdon, *British Assoc. for the Adv. of Science*, 1882, pp. 496-8.

†W. Siemens' English patent, 4,208, 1878, see Borchers' *Electric Smelting*.

inventions were described in 1885.* Their furnace was heated by passing an electric current through coarsely powdered charcoal or gas carbon. This new method was used for a variety of purposes, one of these being the production of aluminium alloys by heating a mixture of alumina and carbon with copper or some other alloying metal.

Fig. 4 represents the Cowles furnace for aluminium alloys. It consists of a rectangular brick chamber fitted with inclined carbon electrodes, A and B, and filled with the mixture of alumina, carbon and copper. The electric current flows between the electrodes through some pieces of retort carbon, C, and thus heats the charge, which, when heated, carries part of the current. The gases resulting from the chemical reaction escape and burn at D, and the molten alloy collects at the bottom of the furnace.

In 1886, Hall,† and Heroult‡ patented processes for the production of aluminium, and their processes, as now used, consist

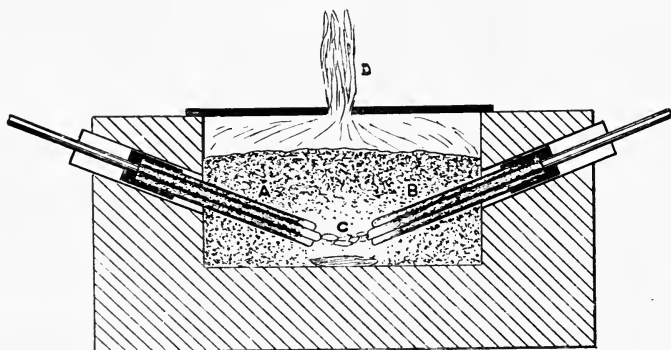

Fig. 4.—Cowles' Furnace for Aluminum Alloys.

keeps the material fused.

in passing an electric current through fused compounds of aluminium; the electrolytic action of the current liberates the aluminium from these compounds, and the heat of the current

Fig. 5 may be considered to represent either the Hall or the Heroult furnace. Each of these consists of an iron tank, A, lined with carbon, B, and provided with a number of carbon rods, C,

*Dr. T. Sterry Hunt, *Amer. Inst. Min. Eng.* (Sept. 16, 1885), vol. xiv., p. 492. Prof. C. F. Mabery, *Amer. Assoc. for the Adv. of Science*; Aug. 28, 1885, vol. xxxiv., p. 136. E. H. and A. H. Cowles, U.S. patents, 319,795 (1884), see *Borchers' Electric Smelting*; and 324,658 and 324,659 (1885), see *Richards' Aluminium*.

†C. M. Hall, U.S. patents 400,766 and 400,664, April 2, 1889 (applied for July 9 1886), see *Richards' Aluminium*.

‡Paul Heroult, French patents, 175, 711, April 23, 1886, and 170,003, April 15, 1887, see *Richards' Aluminium*.

which dip into the fused electrolyte, E, contained in the tank. The carbon rods are made the positive and the tank the negative electrode. The electrolyte consists chiefly of cryolite, and alumina—the purified ore of aluminium—is added at intervals. The electrolytic action of the current splits up the alumina into aluminium and oxygen; the former collects in the fused state at the bottom of the tank, while the latter is liberated in contact with the carbon rods, and consumes them, the loss of carbon being about equal in weight to the aluminium produced.

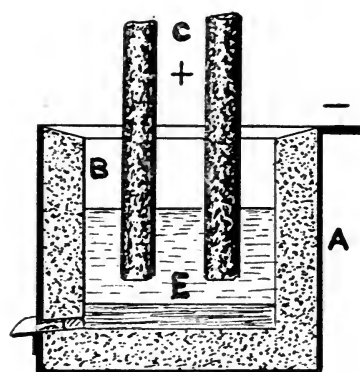

Fig. 5.—Aluminium Furnace.

It will be noticed that, while the apparatus resembles Siemens' vertical arc furnace in general appearance, no arc is formed in this case. The current flows through the electrolyte from the carbon rods to the melted aluminium, and in doing so produces enough heat to keep the cryolite in a state of fusion, at a temperature of nearly 900°C . ($1,600^{\circ}\text{F}$.).

All the aluminum at present produced comes from the electric furnace. During the year 1905 the output of aluminium in the United States alone amounted to 10,000,000 pounds,* whereas, in 1885—before the electrical process was invented—it was only 283 pounds.

The next stage in the history of the electric furnace is marked by the classical experiments and researches of Henri Moissan.† These researches were commenced in 1892, and had for their objective the manufacture of artificial diamonds. Moissan worked in accordance with scientific method, and, although his researches were not conducted with a view to technical results, his unique experiments have given a great impetus to the commercial use of the electrical furnace, as well as establishing on a scientific basis our knowledge of chemistry at the high temperatures used in the electric furnace.

*Mineral Industry, vol. xiv., p. 11.

†H. Moissan, Description d'un nouveau four électrique, Comptes Rendus de l'Acad. des Sciences, vol. cxv., p. 1031, Dec., 1892.

H. Moissan, Le Four Électrique, Paris, 1897.

H. Moissan, The Electric Furnace; trans. by Victor Lenher, 1904.

Fig. 6 indicates the type of furnace he usually employed. It consists of two blocks of limestone, A and B, and two carbon rods, C and D, to which the electrical connections are made. A cavity is hollowed out in these blocks, and the material to be heated is placed in a crucible, E, of carbon or magnesia. As even lime melts and volatilizes at the temperature of this furnace, a lining of alternate layers of carbon and magnesia was arranged as shown in the figure, in order to withstand, as far as possible, the heat of the arc.

In some of these experiments Moissan converted two or three hundred electrical horse-power into heat in a furnace of only a few

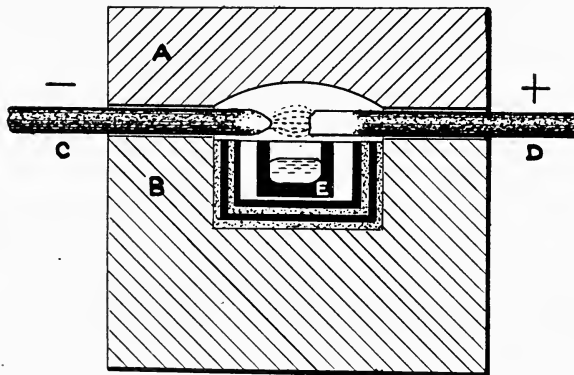

Fig. 6.—Moissan's Furnace.

inches internal dimensions. At the enormously high temperature of his furnace everything melts or turns to vapor. Carbon is the most refractory substance known, and even that turns to graphite and volatilizes; magnesia, another very refractory substance, melts at the highest temperature of the furnace and vaporizes. Lime, quartz, and alumina all melt and boil in the furnace. Gold, copper, iron, and, in fact, all the metals can also be melted and boiled in the electric furnace.

An improved form of the Moissan furnace* has recently been described, in which an electric current of 1,000 amperes at from 50 to 150 volts is employed. In the case of direct current this would mean 70 to 200 horse-power, and, while this is not quite as

*Engineering, March 23, 1906, vol. lxxxi., p. 381.

much as Moissan sometimes used, it is more than is often available for scientific experimental work. In such a furnace it is easy to produce a temperature more than double that usually obtainable by the combustion of fuel, and it is, therefore, an invaluable apparatus in the hands of the metallurgist and the chemist.

Moissan also experimented on the reduction of metals from their oxides, and found, as had, indeed, been stated by C. F. Mabery* in 1885, and by Dr. W. Borchers, in 1891, that carbon will reduce any metal from its oxide at the temperature of the electric furnace. Not only will carbon reduce any metal from its oxide, but at this high temperature carbon will also combine with the metal itself to form a carbide. The production and properties of many of these carbides were studied by Moissan.

One of the most spectacular of his experiments was the production of the diamond. This is a crystallized form of carbon, and if a suitable solvent were available it should be possible to crystallize carbon as diamonds. Moissan found such a solvent in iron and certain other metals. In the electric furnace these metals dissolve notable quantities of carbon, and by cooling them under suitable conditions Moissan was able to obtain some of the carbon as microscopical diamonds, which he isolated by dissolving the metal in acids. The present writer, in common with other experimenters, has repeated this production of the diamond, and has also seen what appeared to be a diamond, which had been found imbedded in a piece of iron or steel produced by ordinary smelting methods.

Although diamonds are not yet manufactured in ton lots, Moissan's researches on the conversion of carbon into graphite, and on the production of calcium carbide, have been followed by important commercial developments. The formation of calcium carbide in the electric furnace was independently achieved in 1893 by T. L. Willson, who developed the manufacture of the carbide on commercial lines.†

Fig. 7 illustrates the Willson carbide furnace, consisting of an iron crucible, A, the base of which has a carbon lining, D. The crucible is connected to one cable from the dynamo or transformer, while the other cable is connected to a large carbon electrode, B C, suspended within the crucible. The arc being started between C and D, the charge of powdered lime and coke is fed in

*C. F. Mabery, (loc. cit.).

†Industries and Iron, 1896, vol. xx., p. 322.

around C, and in the heat of the arc the lime is reduced by means of the coke to the metal calcium, and this in turn reacts with more coke to form a carbide.

These reactions may be represented by the following chemical equations, which also indicate the relative amounts of lime and coke to use in the charge:—

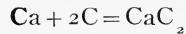
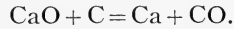

The calcium carbide, when formed, is fusible at the temperature of this furnace, and forms a pool beneath the electrode, B C, and by gradually raising this electrode, a mass of carbide is built up. When the crucible is nearly filled, the operation is stopped and the crucible allowed to cool before turning out the block of carbide.

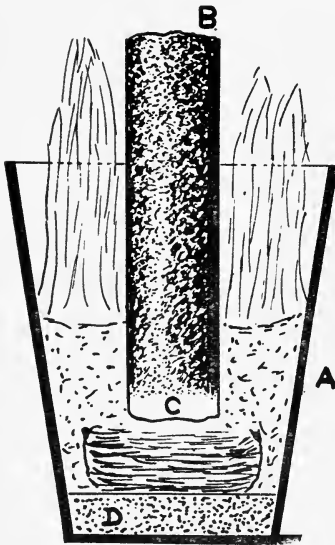

Fig. 7.—Willson's Carbide Furnace.

The carbonic oxide produced by the reaction escapes and burns in the upper part of the crucible, as is indicated in Fig. 7. Many other forms of carbide furnaces have been devised, and are now being operated on a large scale, some of these being intermittent, like the Willson furnace, whilst others are continuous in action. The world's production of calcium carbide in 1904 amounted to 90,000 tons. The value of calcium carbide depends, as is well known, upon the ease with which it acts upon water to form the valuable illuminating gas, acetylene.

Another important carbide, produced in the electric furnace, is carborundum, a carbide of silicon, SiC. The discovery of carborundum by E. G. Acheson in 1891 is described by himself in an interesting lecture on "Discovery and Invention."* Mr. Acheson was attempting to harden clay by impregnating it with carbon in an improvised electric furnace. After the experiment he noticed a few bright specks at the end of the carbon electrode. These specks were found to be hard enough to cut not only glass, but

*The Electric Journal, Pittsburgh, 1906.

even the diamond itself, and were the origin of the important carborundum industry.

Carborundum is made by placing a mixture of sand and coke with smaller amounts of sawdust and salt in a firebrick chamber, and passing an electric current through a core of carbon placed in the middle of the charge. The sand, in the charge, becomes reduced to silicon, and combines with carbon to form carborundum, which, at the high temperature (over $2,000^{\circ}\text{C}.$) of the furnace, assumes a beautiful, iridescent, crystalline form, and is of such extreme hardness that it has proved to be a very valuable abrasive. It is now widely used as a grinding agent in the metal trades and other industries, and it is also useful as a refractory lining for electric and other furnaces, and as a deoxidizing addition in the manufacture of steel.

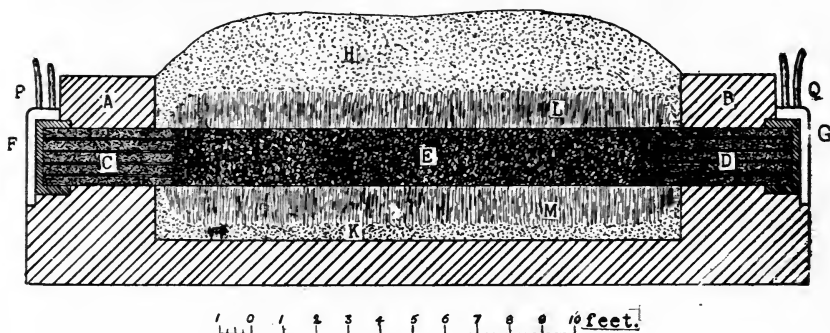

Fig. 8.—Acheson's Carborundum Furnace.

The furnace employed* is shown in Fig. 8, and consists of two permanent end walls, A and B, which support large bundles of carbon rods, C and D, in heavy bronze holders. The current is carried between C and D by a core of broken carbon, E, and as the charge does not fuse, this core remains in position until the end of the operation. A layer of brilliant graphite was usually found between the core and the crystalline carborundum. This graphite resulted from the decomposition of the carbide in the hottest part of the furnace. From this observation Acheson evolved the artificial production of graphite, which he patented in 1896.† It consists in heating coke, anthracite or other form of carbon containing a small amount of iron oxide or certain other substances.

*The Carborundum Furnace, F. A. J. FitzGerald. *Electrochemical Industry*, vol. iv., p. 53, 1906.

†The Conversation of Amorphous Carbon to Graphite, F. A. J. FitzGerald, *Journal of the Franklin Institute*, Nov., 1902.

The iron and other impurities in the carbon are volatilized at the high temperature of the electric furnace and leave the carbon very pure and converted into graphite. As much as 1,000 electrical horse-power is consumed in one of these furnaces, producing a temperature of over 2,200°C.

The manufacture of carborundum, graphite, siloxicon and other products of the Acheson electric furnaces at Niagara is more fully described in Chapter vi.

Calcium carbide has been one of the most important products of the electric furnace, and its manufacture still consumes more electrical power than that of any other product. It was a financial crisis in the carbide industry that led to the electric smelting of iron, steel, and the other iron alloys.*

A few years ago the production of calcium carbide became larger than the demand, and this forced some manufacturers to turn their attention to other methods of utilizing their electric furnaces. With this object experiments were made in France and elsewhere about the year 1900 on the production of ferro-chrome,† ferro-silicon, and the other ferro alloys; and these experiments were so successful that not only have the new processes been able to compete with existing methods, but, in the case of ferro-chrome at any rate, the electric product has captured the market.

The ferros are alloys of iron, with manganese, chromium, silicon, or some other metal, and they usually contain a notable amount of carbon, being, in fact, cast iron, in which part of the iron has been replaced by another metal. Some of these are used in the production of open-hearth and Bessemer steel, and others for the production of special alloy steels. Ferro-nickel, ferro-tungsten, ferro-titanium and ferro-molybdenum have also been employed in steel making.

The carbide furnaces, which were lined with carbon, were satisfactory for the production of these carburized materials, but certain changes were necessary before they could be used for the manufacture of steel. In France, Heroult,‡ and in Sweden, Kjellin§ succeeded in adapting the furnace to the production of

*Albert Keller, *The Application of the Electric Furnace in Metallurgy*, Journ. Iron and Steel Inst., 1903, No. I., p. 161.

†Ibid, pp. 162 and 166-169.

‡Heroult Steel Furnace. *Electrochemist and Metallurgist*, vol. i. (1901), p. 196, *Electrochemical Industry*, vol. 1, (1902-3), pp. 63, 287, 449.

§Kjellin Steel Furnace. *Electrochemist and Metallurgist*, vol. i. (1901), p. 90; *Electrochemical Industry*, vol. i. (1902-3), pp. 141, 376, 462, 576.

good quality steel from scrap steel, pig iron, etc.; and good crucible and special alloy steels have for some years been produced commercially in the electric furnace. The original patents of these pioneers of electric steel-making were taken out about the year 1900,* just one hundred years after the discovery of the voltaic battery.

The origin of the electric smelting of iron ores was, however, somewhat earlier than this. In the year 1898 Captain Stassano,† in Italy, patented his electrical furnace for smelting iron ores, and in the following year demonstrated the working of his process. Quite a sensation was produced by his experiments, as although it was not surprising to learn that iron ores could be smelted by electricity, the ordinary price of electric power was so high that it appeared preposterous to attempt to use it in competition with coke in the blast furnace.

It is a matter of general knowledge that the retail price of any commodity is higher, and sometimes even several times as high as the wholesale price, or the cost of production; but it was probably not generally realized until quite recently that the small consumer of electric light pays about one hundred times as much for electricity as the actual cost of producing it from a good water-power. This enormous difference had given an exaggerated idea of the costliness of electrical power, and was, no doubt, largely responsible for the skepticism with which Stassano's early experiments were received. These experiments of Stassano, although not as yet commercially successful, have, no doubt, impressed on many minds the financial possibility of electric smelting in general, and a large crop of such processes has followed.

Some other furnaces suitable for smelting iron ores are those of Keller, Heroult and Harmet, which are described and illustrated in Chapter v.

In view of the great importance to Canada of developing the electric smelting of iron ores, the Canadian Government appointed in 1903 a Commission under Dr. Haanel to report on the electrothermic processes for the smelting of iron ores and the making of steel in operation in Europe. The Commission visited Europe in 1904 and saw the Heroult, Keller and Kjellin furnaces in commercial operation making steel and ferro alloys. At Dr. Haanel's

*The Colby induction steel furnace was patented in 1890. See *Electrochemical Industry*, vol. iii. (1905), p. 299, and vol. v. (1907), p. 232.

†Stassano Steel Furnace. *Electrochemist and Metallurgist*, vol. i. (1901), p. 230; *Electrochemical Industry*, vol. i (1902-3), pp. 247, 363.

request the production of pig iron from the ore was also demonstrated in the Heroult and Keller furnaces. A voluminous report* was published after the return of the Commission, and Dr. Haanel was so well satisfied with the possibility of smelting iron ores electrically in countries where coal was scarce and water-power was abundant that he obtained a further grant from the Government, and with the help of Paul Heroult carried out a series of experiments during the spring of 1906 at Sault Ste. Marie on the electric smelting of Canadian iron ores.† As a result of these experiments plants for the commercial smelting of iron ores in electric furnaces are being erected at Welland, Ont., and at Baird California.

*Report of the Commission appointed to investigate the different electrothermic processes for the smelting of iron ores and the making of steel in operation in Europe. Ottawa, 1904

†Report on the experiments made at Sault Ste. Marie, Ont., under Government auspices in the smelting of Canadian iron ores by the electro-thermic process. Ottawa, 1907.

CHAPTER II.

DESCRIPTION AND CLASSIFICATION OF ELECTRIC FURNACES.

The Electric Furnace may be described as an appliance in which materials can be submitted to a high temperature by the dissipation of electrical energy. This definition does not include all cases of electrical heating; and with advantage might be limited to the production of temperatures above a red heat. In a number of instances such as the production of sodium and aluminium, the electric current is required mainly for isolating the metal by electrolysis, and only incidentally for producing heat. These processes are usually considered to be furnace operations, because a high temperature is produced; and it has been suggested, by Mr. J. Wright,* that electrolysis should be classed as a furnace process, when fused anhydrous salts are employed; excluding the more familiar electrolytic processes in which aqueous electrolytes are used.

Heat is produced whenever an electric current encounters any resistance to its flow; the energy, producing the current, being transformed into heat.† Even the best electrical conductors oppose some resistance to the flow of an electric current, and work must consequently be done in maintaining the current. If an electric circuit is made, in part, of a good conductor (such as a short, stout copper cable) and, in part, of a poor conductor (such

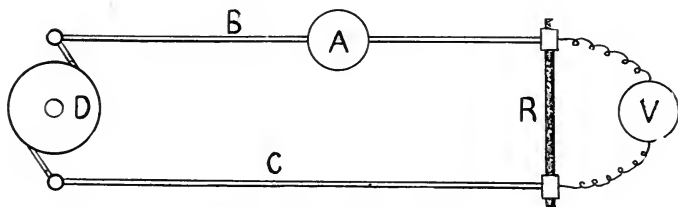

Fig. 9.—Electric Circuit.

as a thin rod of carbon) the greater part of the heat will be produced in the poor conductor, which may even become red hot, while the remainder of the circuit remains cool.

*Author of "Electric Furnaces and Their Industrial Application."

†A part of the energy is sometimes changed into chemical energy or into other forms of electrical energy.

Fig. 9 represents such a circuit: D is a dynamo; B and C are stout copper wires or cables, and R is a carbon "Resistance" or "Resistor;" that is to say, an electrical conductor made of carbon that offers a considerable resistance to the flow of the current. The windings in the dynamo are of copper, and these and the cables B and C are so stout, that the resistance they offer to the flow of the current is only small. In this circuit, mechanical work is constantly required to turn the dynamo, and this work is converted into heat mainly in the resistor R; and to a less extent in the conductors B and C, and the dynamo D. Such an arrangement may represent an electric **resistance** furnace operated by a dynamo. The work spent in driving the dynamo, is converted into heat, and by giving to the furnace a far higher resistance than that of the remainder of the circuit, we can obtain nearly all the heat in the furnace; only a small proportion being wasted in the dynamo and conducting cables. The amount of heat developed depends upon the strength of the electric current, as well as on the amount of resistance it meets. By increasing the furnace resistance, the current is decreased; consequently, beyond a certain point, less heat will be developed in the furnace.

An electric current is measured in "amperes," the electrical pressure producing the current is measured in "volts," and the electrical resistance of a conductor is measured in "ohms." Using these units, the electric current flowing around a circuit is equal to the electrical pressure or E.M.F. (electro-motive-force) driving it, divided by the electrical resistance of the circuit.

When an electric current flows through a resistor, as in Fig. 9, the amount of heat produced is proportional to the resistance, and to the square of the current; or, to the E.M.F. and the current. Taking as a unit the heat that would raise the temperature of one gram of water from 0°C. to 1°C., it is found that—

$$H = 0.24C^2 R t = 0.24 E C t,$$

where,—

H = heat produced in gram centigrade units,

C = current in amperes,

R = resistance in ohms

E = electro-motive-force in volts,

t = time in seconds.

In the circuit shown in Fig. 9 the current C would be measured in amperes by means of an ammeter, A, placed in one of the cables; the E.M.F., E., in volts by means of a voltmeter,

V, connected to the terminals of the resistor; and the resistance R, in ohms, would be deduced from the relation— $CR=E$. The above considerations are only exact in the case of an electric current flowing steadily in one direction; in the case of alternating currents a sort of electrical inertia is observed which modifies these results.

In the **arc** furnace, the electric current encounters not only an inert resistance, but also, an opposing electrical force. Both the resistance and the opposing electrical force cause the energy of the current to be turned into heat, and to contribute to the heating of the furnace. A similar opposing electrical force is present in an electrolytic furnace, such as is used for the production of aluminium. In the latter case, however, the work done in overcoming this force, is turned into chemical energy (the isolating of aluminium from alumina) instead of into heat. In most furnace operations, chemical and physical changes are produced, and these increase or diminish the amount of heat liberated in the furnace.

An electric furnace consists of the following essential parts and accessories:—

(1) **Some conducting material heated by the passage of the current.** This may be a vapor, as in the electric arc; or a solid, such as coke; or a liquid, such as molten slag or molten steel.

(2) **An envelope of refractory material.** The walls, floor and roof of a furnace are needed to conserve the heat, to retain the charge, to exclude the air and to support the electrodes and the charging and discharging apparatus.

(3) **Electrodes, or conductors for bringing the current into the furnace,** carbon rods are usually employed for this purpose. They are subjected to the heat of the furnace at one end, and at the other end must be sufficiently cool to permit of making electrical contact by means of special holders with the cables bringing the current to the furnace. In some furnaces electrodes are not needed, the current being generated by induction in the furnace itself.

(4) **Electrode holders.**—These are usually metal clamps for holding and making electrical contact with the carbon electrodes; provision being made for preventing the excessive heating of the holder.

(5) **Charging and discharging facilities.**—Some furnaces are intermittent in action, the charge being added, heated in the furnace and then removed, before the fresh charge can be introduced. Other furnaces are continuous in action, involving the

periodic, or continuous additions of the raw material, and removal of the products.

Apart from the furnace itself, the following operating factors have to be considered:—

(6) **Source of electric current.**—The electric current is produced by means of a dynamo, and as it is usually supplied at a higher voltage than is suitable for the furnace, a transformer may be required to reduce the voltage; the amount of current being simultaneously increased almost proportionately to the reduction in the voltage. The current may be alternating, or direct, but an alternating current is usually preferred, as it can be transformed more readily from one voltage to another. In cases where electrolysis is required, as in the production of aluminium or sodium, the direct current can alone be used.

(7) **Cables, measuring instruments, and regulating devices.** Cables are used for bringing the electric current from the transformer or dynamo to the furnace. Measuring instruments, such as ammeters, voltmeters and wattmeters are used for measuring and recording the current, electro-motive-force and electrical power supplied to the furnace. Regulating devices are required for advancing the electrodes as they are consumed in the furnace, and for regulating by this means, or in some other way, the amount of current flowing through the furnace.

Classification.

The usual classification of electric furnaces depends primarily upon the nature of the resistor used to develop the heat. Thus there are arc furnaces, in which the heat is developed in the electric arc; and resistance furnaces, in which the heat is developed by the passage of the current through a solid or liquid resistor. The classification may depend, also upon the manner in which the heat is transmitted to the charge; thus in arc furnaces the heating may be direct, as in Siemens' vertical arc furnace, in which the metal to be melted forms one pole of the arc; or indirect, as in his horizontal arc furnace, where independent electrodes are employed, and in which the heat is transmitted from the arc to the charge by radiation and conduction.

In resistance furnaces the charge to be heated may itself constitute the resistor, or else an independent resistor may be employed. The latter nearly always consists of a solid core, usually of carbon, and it may be surrounded by the charge that is to be heated, or imbedded in the walls of the furnace. A charge that

is to be heated directly by the passage of the current, may be either solid or liquid, and in the case of a liquid charge, the electric current may produce heat merely, or may also produce electrolysis.

The following classification is based on these considerations, and includes examples of each class.

Arc Furnaces.

The heat is produced by one or more electric arcs.

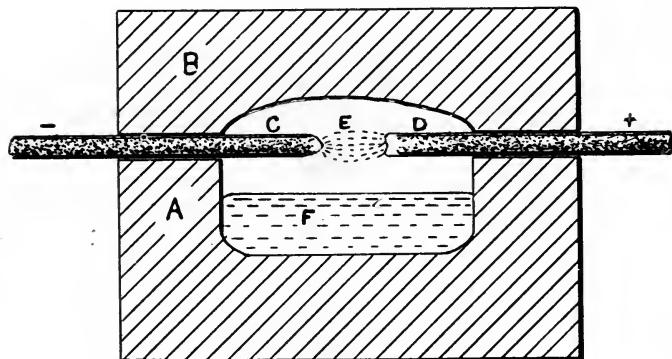

Fig. 10.—Independent Arc Furnace.

(1) **Independent arc furnaces.**—The arc is independent of the charge to be heated; being formed between two or more movable electrodes. The charge is heated by radiation from the arc, which is usually horizontal.

Fig. 10 shows such a furnace, consisting of a refractory chamber, A.B., in which an arc, E, is formed between the movable carbon electrodes C and D; the material to be heated being shown melted at F.

Moissan's furnace, Fig. 6, Siemens' horizontal arc furnace, Fig. 3, and Stassano's steel-making furnace are examples of this class. The Stassano furnace, Fig. 37, p. 130, consists of a chamber lined with magnesia bricks, and provided with three carbon electrodes, between which a three phase arc plays. The ore or other material is placed in the chamber below the level of the arc, and is heated by radiation.

(2) **Direct heating arc furnaces.**—The charge in the furnace forms one pole of the arc and is thus heated directly as well as by radiation. The arc is usually vertical.

Fig. 11 represents an arc furnace in which the material D, to be heated, forms one pole of the arc. A is a chamber lined with refractory material, and B and C are the two electrodes: the upper one, B, is movable; the lower, C, is fixed, forming part of the bottom of the furnace, and making electrical contact with the charge D. The furnace is started by lowering B until it touches D, thus allowing the current to pass. B is then raised, forming an electric arc between B and D.

Siemens' vertical arc furnace, Fig. 2, Willson's carbide furnace, Fig. 7, and Heroult's steel furnace, are examples of this

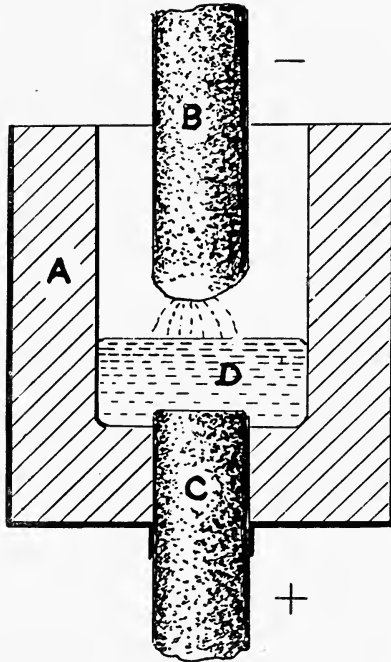

Fig. 11.—Direct Heating Arc Furnace.

class. The Heroult steel furnace, Fig. 23, p. 87, consists of a chamber for containing the molten steel, with two vertical carbon rods dipping through holes in the roof. An arc is formed between each carbon rod and the fused charge; the current entering through one rod, passing through the melted steel and slag, and returning through the other rod. Furnaces of this class are rather less convenient for scientific investigations than the independent arc furnace; because the temperature is less easy to regulate, the

arc is more difficult to control (when the charge consists of cold metal), and the carbon of the electrodes is apt to affect the chemical composition of the charge. On the other hand, the heat is transmitted more directly, thus obtaining a greater economy, and only one movable electrode is needed for each arc.

Resistance Furnaces.

In these, the heat is produced by the passage of the electrical current through some solid or liquid resistor. They may be divided into two main classes, in one of which a special resistor is provided, and in the other the charge itself constitutes the resistor. The second class may be subdivided into two classes; in one of these the current is used merely to heat the charge, while in the other it also produces electrolysis of the fused contents of the furnace. These will be treated, for convenience, as three independent classes.

I.—Furnaces With Special Resistor.

The resistor is a solid, and is imbedded in the walls of the furnace, or in the charge itself.

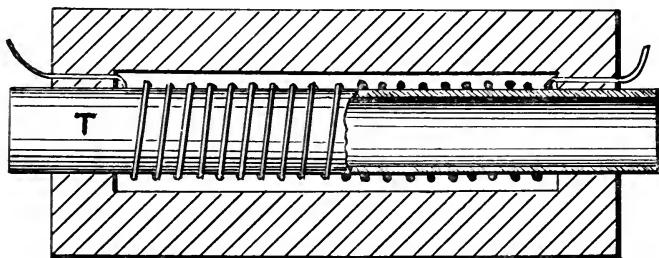

Fig. 12.—Electrical Tube Furnace.

(1) **Furnaces with the resistor imbedded in the walls.** The furnace shown in Fig. 12 may be taken as an example, it consists of a tube T, often of porcelain, a spiral of platinum wire, and a heat retaining envelope or covering. An electric current passes through the wire and heats it to any desired temperature below its melting point, 1775°C. , or 3227°F. , and ultimately the tube and its contents may be heated nearly to the same temperature. The substance to be heated is placed in the tube T. This arrangement is convenient for heating a material in any particular gas, and for observing the operation; as this can be done through glass,

or mica windows at the ends of the tube. Provision must be made for preventing the displacement and short circuiting of the coils of wire when expanded by the heat. The temperature that can be attained in this furnace depends upon the refractory qualities of the tube, and envelope, as well as on the melting point of the platinum itself, and in practice, the temperature attained would be far short of the melting point of the platinum wire.*

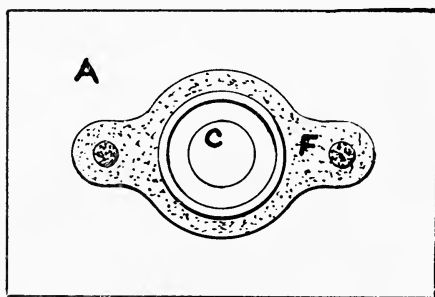
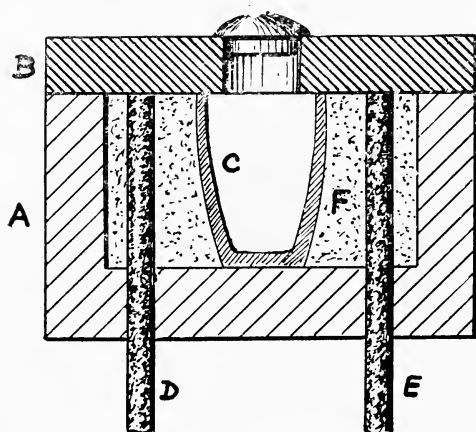

Fig. 13.—Electric Crucible Furnace. a crucible C, and carbon electrodes D and E. A receptacle is formed

This furnace is very convenient for laboratory experiments on a small scale, and at moderate temperatures, but its use is restricted by the high price of platinum.† A somewhat similar furnace in which the use of platinum has been avoided is shown in Fig. 13, which represents in sectional elevation, and in plan with the cover, B, removed—a small electrical crucible furnace, constructed at McGill University, and intended for melting small quantities of metals. It could, however, be made considerably larger, and be used for brass or steel melting. The furnace consists of two fire clay

*A furnace, in which a crucible of fused quartz is surrounded by heating coils of platinum strip, has been patented by W. H. Bristol, Electrochem, Ind., vol. v., p. 55.

†These furnaces can be obtained in several forms from dealers in chemical apparatus. A furnace suitable for heating a small crucible is described by Prof. H. M. Howe in his "Metallurgical Laboratory Notes," p. 37.

in the block A to contain the crucible and electrodes, and broken coke, F, is packed around them. The current passes from D to E through the coke, which becomes hot and heats the crucible and its contents. The temperature can be regulated by a rheostat in series with the furnace. The whole furnace is enclosed in a metal box with a thick asbestos lining to prevent loss of heat.*

Furnaces of this type can now be made more satisfactorily by the use of a special resisting material called kryptol† which would replace the coke in the above description.

The Conley‡ ore smelting furnace is a large scale example of this class. One form of the Conley furnace consists of a shaft down which the ore passes and of carbon resistors imbedded in the walls of the furnace. The resistors are heated by the passage of a current, and communicate their heat to the ore passing over them.

Small tube furnaces heated by spirals of platinum wire, are very useful for experimental purposes, but commercial furnaces on these lines have been less successful. This is mainly on account of the difficulty of maintaining resistors and adjacent parts of the furnace, and because, of the slow conduction of heat to the charge, and the large loss of heat through the furnace walls.

A rotary electric furnace, the inner walls of which serve as resistors, being sufficiently conducting when heated, has been patented by B. von Ischewsky.¶

Tube furnaces for experimental work, in which the tube is composed of graphite, amorphous carbon, or other conducting material which is heated by the passage of the electric current, have been employed by Potter,§ Harker,* Hutton,† Tucker,‡ and others.

(2) **Furnaces with the resistor imbedded in the charge.**—The resistor is usually of carbon and horizontal.

*Similar furnaces have been described by FitzGerald, *Electrochemical Industry*, vol. iii., pp. 55 and 135.

†Kryptol, see p. 149.

‡Conley furnaces, *Electrochemical Industry*, vol. i., p. 426, and vol. ii., p. 424.

¶Ischewsky furnace, *Electrochemical Industry*, vol. v., p. 141.

§H. N. Potter, *Electrochemical Industry*, vol. i., pp. 187, 188 and 250; vol. ii., p. 203; vol. iii., p. 346, and vol. iv., p. 191.

*J. A. Harker, *Electrochemical Industry*, vol. iii., p. 273.

†R. S. Hutton and W. H. Patterson, *Electrochemical Industry*, vol. iii., p. 455, (1905).

‡S. A. Tucker, *Electrochemical Industry*, vol. v., p. 227, (1907).

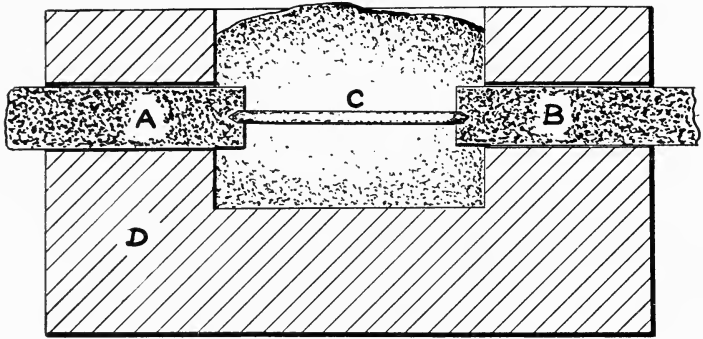

Fig. 14.—Borchers' Resistance Furnace.

The simplest example is Borchers' experimental resistance furnace, Fig. 14,* in which a thin pencil of carbon C is supported between stout carbon rods A and B, and the charge to be heated surrounds C. The current flows between A and B through C, and may raise the latter to a white heat. The charge serves in part as an envelope to retain the heat.

Acheson's carborundum furnace, Fig. 8, is the most important example of this class. In this furnace the conducting core is composed of granular carbon, and is supported and surrounded by the material to be heated. The furnace is efficient, because the heat is developed in the midst of the charge, which serves to retain it. The temperature can also be exactly regulated by varying the current, while by using a number of cores, as in the siloxicon furnace, Fig. 41, page 154, it is possible to obtain a fairly uniform temperature throughout a large portion of the charge. On the other hand, when the furnace is in operation, it is impossible to regulate the resistance of the core,† and since this decreases considerably as the furnace becomes hotter, the current, if supplied at a constant voltage, may increase during the work of the furnace until it becomes too great for the dynamo, or transformer from which it is supplied; thus involving the use of special apparatus for regulating the voltage. As the material to be heated acts as an envelope to retain the heat, and as the charge does not become fused, the outer walls can be of the simplest de-

*Borchers' *Electric Smelting and Refining*, 1897 Ed., Figs. 54, 55, 172. and *Electrochemical Industry*, vol. iii., p. 215.

†In small furnaces of this type the resistance of the core can be regulated, within moderate limits, by placing weights on the charge.

scription; merely serving to retain the charge in position. This furnace would not be directly applicable in case the charge were to fuse, since the core would become broken. The furnace is also essentially intermittent in action, as the charge cannot pass continuously through it, and on that account it is less efficient, since it must be allowed to cool between successive operations. Although a core is provided in this furnace to carry the current, a portion of the latter is undoubtedly carried by the charge itself.

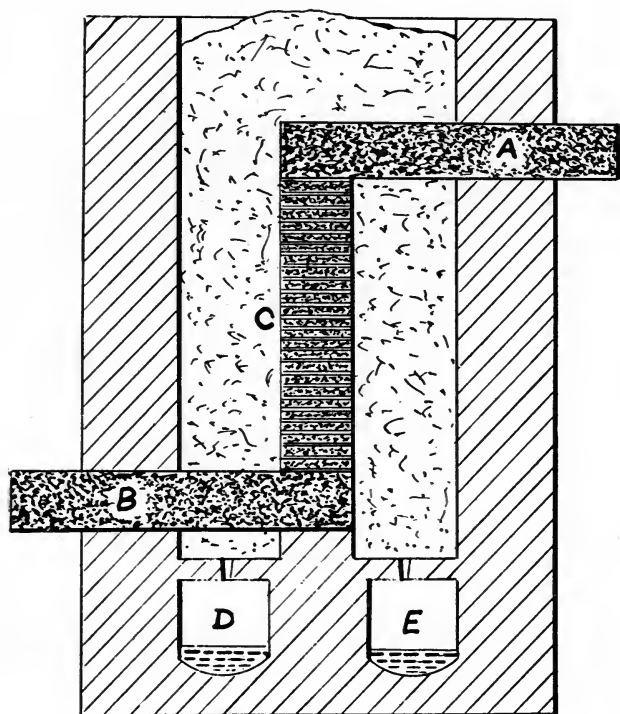

Fig. 15.—Tone's Resistance Furnace.

In the Cowles furnace for aluminium alloys, Fig. 4, the charge becomes partly fused, and no doubt serves to carry the current, but at the beginning of the operation the current is carried by a carbon core and so the furnace may be included in this class.

Tone's resistance furnace,* for the reduction of metals is shown in Fig. 15. The central resisting core C is placed vertically

*U. S. patent 754,122, see *Electrochemical Industry*, vol. ii., (1904), p. 111, and Wright's "Electric Furnace," p. 144.

in order to permit of continuous charging, which would break down a horizontal core. It is constructed of carbon blocks, piled upon each other in such a way* as to obtain a high electrical resistance. A and B are carbon electrodes for making electrical connection with the core. The charge is fed in around C, and the reduced and melted metal flows through small holes at the base of the furnace into the receptacles, D and E.

II.—Furnaces without Special Resistor and without Electrolytic Action.

In these furnaces the material to be heated forms the resistor, and may be solid or liquid, or may become molten during the operation. They may accordingly be divided into three classes:—

(1) **Furnaces with solid resisting contents.** The material to be heated in these furnaces is sufficiently conducting to serve as a resistor, and remains solid during the operation of the furnace. Such furnaces are in consequence usually intermittent in action, the charge being heated and allowed to cool before it can be removed from the furnace.

The Acheson graphite furnaces, for the manufacture of graphite from anthracite coal, Fig. 38, p. 145, and for graphitizing carbon electrodes, Fig. 39, p. 145, are the most important members of this class. The material of the charge is a sufficiently good electrical conductor to permit the current to pass without needing any special conducting core, and the resulting graphite, being quite infusible, remains in position in the furnace, which must therefore be allowed to cool before the charge can be removed. Other examples are the Cowles zinc furnace, Fig. 42, p. 157, the Johnson zinc furnace, Fig. 43, p. 158, and the Thomson electric welding apparatus.

(2) **Furnaces with melting resisting contents.** The great majority of electric smelting furnaces are in this class. The current passes between electrodes through the contents of the furnace, and these contents melt and run down in the furnace. Such furnaces are almost invariably continuous in action, fresh material being supplied at intervals, and the molten products being tapped off while the furnace is running. Almost all materials, when in a melting condition, are sufficiently conducting to carry the current, although they may scarcely conduct at all when cold.

In these furnaces the current may pass between a pair of lateral electrodes as in Fig. 16, or it may pass from one or more

*The figure does not show the arrangement very clearly. The blocks are laid across each other so as to form a hollow square tower with openings in the sides.

movable electrodes to a fixed electrode forming part of the bottom of the furnace as in Fig. 17. The furnace illustrated in Fig. 16, consists of a chamber provided with lateral carbon electrodes and one or more tapping holes. It has a striking resemblance to a blast furnace, the electrodes representing the tuyeres. The ore becomes heated and reduced to the metallic state in the upper

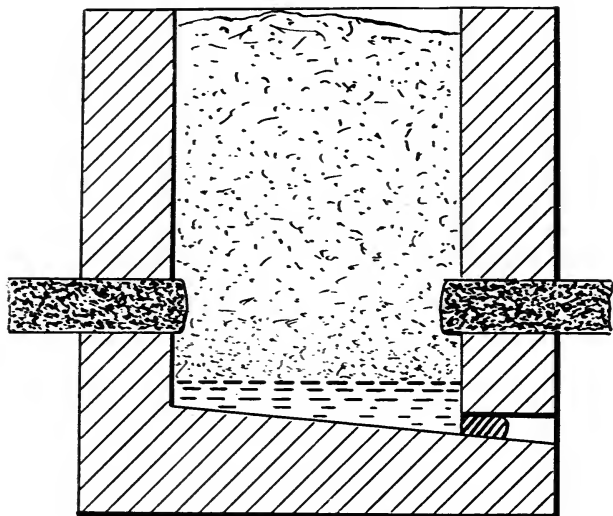

Fig. 16.—Shaft Furnace with Lateral Electrodes.

part of the furnace, and the whole charge melts in the zone between the electrodes, and can be tapped out at the bottom. The current passes in part through the molten slag and metal in the bottom of the furnace, as well as directly through the melting ore between the two electrodes. An objection to this type of furnace is that the current cannot be effectively regulated by moving the electrodes.

The Harmet furnace, Fig. 31, p. 114, is an example of this class.

Fig. 17 represents a furnace with one large electrode hung in the middle, surrounded by the material to be heated. The other electrode, B, is fixed, forming part of the bottom of the furnace; and merely serves to make electrical contact with the fused material in the furnace. An advantage in this furnace is that the current can be easily regulated by raising or lowering the upper electrode. Moreover, the hottest part of the charge is in the middle of the furnace, thus leading to a greater economy of heat and to a longer life of the furnace walls.

The Heroult ore smelting furnace, Fig. 29, p. 108; the Haanel-Heroult furnace, Fig. 32, p. 116, and the Salgues zinc furnace, Fig. 45, p. 160, are in this class.

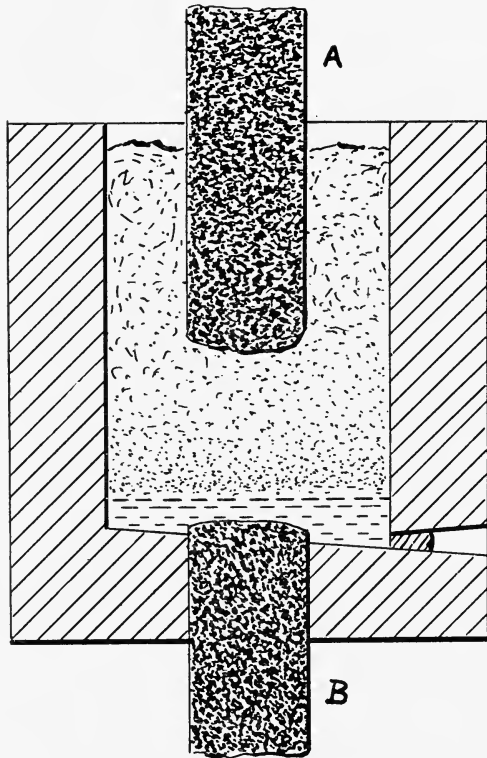

Fig. 17.—Shaft Furnace with Central Electrode.

(4) **Furnaces with liquid resisting contents.** These consist of a refractory reservoir, containing fused slag, or metal, through which the electric current passes. The liquid becomes superheated by the passage of the current, and is able to melt the fresh material, which can be added at intervals or continuously. The current is introduced by carbon electrodes, by water-cooled metal electrodes, or by induction.

The De Laval furnace, Fig. 18, is in this class; it consists of a chamber, A, the lower part of which is divided into two troughs, B and C, containing molten metal, with which electrical contact is made by metal terminals. A molten slag, E, fills the furnace

above the dividing wall, and the electric current flows between B and C through the molten slag. The slag becomes superheated and dissolves the ore, F, which is added through a hole, K, in the top of the furnace. Alternating current should be employed to avoid electrolysis. The slags fills the furnace up to the hole, F, at which it overflows. The metal in the troughs overflows at the spouts, G and H, as fast as it is formed. In order to prevent the current melting away the wall between the troughs a water-cooled metal block, J, is inserted. Even with this precaution

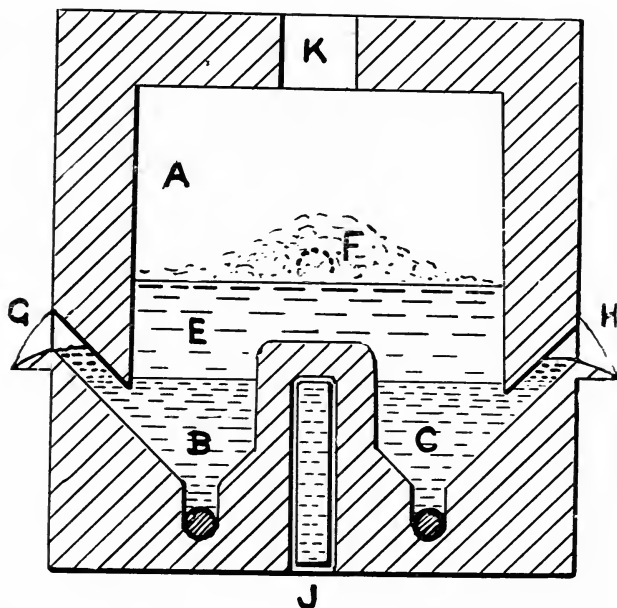

Fig. 18.—De Laval Ore-smelting Furnace.

there is danger of short-circuiting, because the metal in B and C may penetrate to the water jacket, J, thus forming a complete metallic connection between the furnace terminals.

The Snyder induction smelting furnace, Fig. 47, p. 166, resembles the Laval furnace, but the electric current is generated in the Snyder furnace by induction, instead of being led in by metal terminals or electrodes.

Furnaces having resistors of liquid metal are used in electric steel making. Such furnaces consist of a long canal containing the molten steel which becomes heated by the passage of the

electric current. The canal is usually folded backwards and forwards for compactness, and to reduce the loss of heat. The current may be led in through water-cooled metal terminals, as in the Gilchrist furnace, Fig. 28, p. 104; but it is preferably generated directly in the molten metal by induction, the canal forming the short-circuited secondary winding of a transformer, as in the Kjellin steel furnace, Fig. 24, p. 93; the Gronwall steel furnace, Fig. 26, p. 100, and the Colby steel furnace, Fig. 25, p. 97, and Frontispiece.

III.—Electrolytic Furnaces.

In these furnaces the power of a continuous current to divide a fused chemical compound into two component parts is utilized, while the heating effect of the current is also needed to keep the contents of the furnace in a state of fusion. Most chemical compounds can be decomposed in this way, but some behave like the metals and alloys, and carry the current without suffering decomposition. Mixtures of two or more compounds are often employed, as this facilitates the passage of the current and renders the charge more fusible.

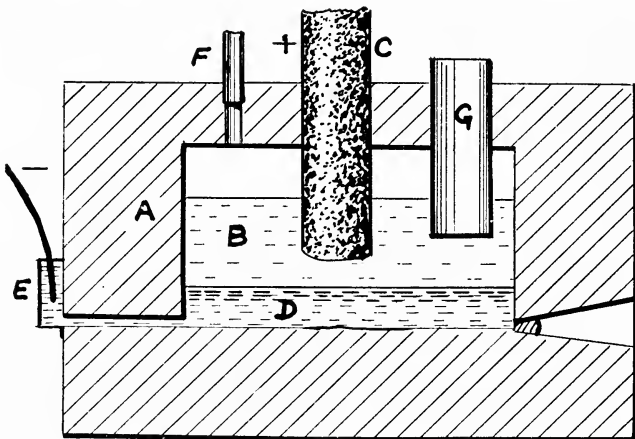

Fig. 19.—Electrolytic Furnace.

Fig. 19, represents a furnace for the electrolysis of fused zinc chloride, it consists of a chamber, A, containing the fused chloride, B. The positive electrode, C, is made of carbon, and dips into

the electrolyte, while the fused zinc, D, resulting from the operation, forms the negative electrode; electrical connection being made with it at E. The passage of the current splits the zinc chloride into zinc, which collects at D, and chlorine, which is liberated at the electrode, C, and is withdrawn from the furnace by the pipe, F. A cylinder, G, passes through the roof of the furnace and dips into the fused electrolyte, to enable fresh chloride to be added without allowing the chlorine to escape.

Furnaces for the production of aluminium (Figs. 5 and 52) are also electrolytic.

The classification adopted in this chapter is shown diagrammatically on the next page; an example of each type being given.

TABLE I.

Classification of Electric Furnaces.

Arc Furnaces	{	Independent Arc (Moissan's furnace) Direct Heating Arc (Siemens' vertical arc furnace).												
Resistance Furnaces	{	<table style="border-collapse: collapse; margin-left: 10px;"> <tr> <td style="padding-right: 10px;">With special Resistor</td> <td style="font-size: 2em; vertical-align: middle;">{</td> <td style="padding-left: 10px;"> Resistor in Walls (electrical tube furnace). Resistor in Charge (carborundum furnace). </td> </tr> <tr> <td style="padding-right: 10px;">Without special Resistor</td> <td style="font-size: 2em; vertical-align: middle;">{</td> <td style="padding-left: 10px;"> <table style="border-collapse: collapse; margin-left: 10px;"> <tr> <td style="padding-right: 10px;">Without Electrolysis</td> <td style="font-size: 2em; vertical-align: middle;">{</td> <td style="padding-left: 10px;"> Resisting contents of furnace (Solid (Graphite furnace). Melting (Héroult ore smelting furnace). Liquid (Kjellin's steel furnace). </td> </tr> <tr> <td colspan="2"></td> <td style="padding-left: 10px;">Electrolytic (aluminium furnace).</td> </tr> </table> </td> </tr> </table>	With special Resistor	{	Resistor in Walls (electrical tube furnace). Resistor in Charge (carborundum furnace).	Without special Resistor	{	<table style="border-collapse: collapse; margin-left: 10px;"> <tr> <td style="padding-right: 10px;">Without Electrolysis</td> <td style="font-size: 2em; vertical-align: middle;">{</td> <td style="padding-left: 10px;"> Resisting contents of furnace (Solid (Graphite furnace). Melting (Héroult ore smelting furnace). Liquid (Kjellin's steel furnace). </td> </tr> <tr> <td colspan="2"></td> <td style="padding-left: 10px;">Electrolytic (aluminium furnace).</td> </tr> </table>	Without Electrolysis	{	Resisting contents of furnace (Solid (Graphite furnace). Melting (Héroult ore smelting furnace). Liquid (Kjellin's steel furnace).			Electrolytic (aluminium furnace).
With special Resistor	{	Resistor in Walls (electrical tube furnace). Resistor in Charge (carborundum furnace).												
Without special Resistor	{	<table style="border-collapse: collapse; margin-left: 10px;"> <tr> <td style="padding-right: 10px;">Without Electrolysis</td> <td style="font-size: 2em; vertical-align: middle;">{</td> <td style="padding-left: 10px;"> Resisting contents of furnace (Solid (Graphite furnace). Melting (Héroult ore smelting furnace). Liquid (Kjellin's steel furnace). </td> </tr> <tr> <td colspan="2"></td> <td style="padding-left: 10px;">Electrolytic (aluminium furnace).</td> </tr> </table>	Without Electrolysis	{	Resisting contents of furnace (Solid (Graphite furnace). Melting (Héroult ore smelting furnace). Liquid (Kjellin's steel furnace).			Electrolytic (aluminium furnace).						
Without Electrolysis	{	Resisting contents of furnace (Solid (Graphite furnace). Melting (Héroult ore smelting furnace). Liquid (Kjellin's steel furnace).												
		Electrolytic (aluminium furnace).												

CHAPTER III.

**EFFICIENCY OF ELECTRIC AND OTHER FURNACES,
AND RELATIVE COST OF ELECTRICAL AND
FUEL HEAT.**

Electricity would generally be preferable to fuel for producing heat, if it were not that the cost of electrical energy is almost invariably greater, and usually many times greater than that of an equivalent amount of fuel. In certain operations, such as the production of carborundum or graphite, electricity must be employed, because a sufficiently high temperature cannot be obtained by the combustion of fuel. In other operations, such as the production of aluminium, the electrolytic action of the electric current is essential to the process. A large number of metallurgical operations, however, were carried on successfully before electric smelting was thought of; and for such purposes electricity is only employed when its greater efficiency and convenience outweigh the usually greater cost. It has recently been realized that electricity can sometimes economically replace coal or coke as a heating agent in operations such as the smelting of zinc or even iron ores, or in the production of steel.

In comparing electricity and coal, we may consider how much heat each will produce, or how much electrical energy will be needed to produce as much heat as one pound of coal would yield on burning. One unit or kilowatt hour of electrical energy will produce 3,415 B. T. U. (British Thermal Units), of heat, and one pound of good quality coal will produce about 14,000 B. T. U. Thus four kilowatt hours are needed to produce as much heat as one pound of coal.

For small consumers, buying electrical energy for lighting at 10 or 15 cents a unit, and coal at \$6 or \$7 a ton, the cost of electrical heat would be one or two hundred times that of coal heat.

As a year consists of 8,766 hours, one kilowatt would yield, if operated continuously for that time, nearly 30,000,000 B. T. U., or one electrical H.P. year would yield 22,320,000 B. T. U.; and as one ton of coal will produce about 31,000,000 B. T. U., it will be seen that an electrical H.P. year produces about 25 per cent. less heat than a ton of good coal; or one ton of coal would produce as much heat as $1\frac{1}{3}$ E. H. P. years. If an electrical H.P. year could be purchased for \$30 and a ton of coal for \$4, the cost of electrical heat, per B. T. U. would be ten times the cost of coal heat.

In localities where water-power can be cheaply developed, and where transportation charges for coal and coke are high, it may be possible to produce electrical power at \$10 or less per E. H. P. year, in large amounts as would be necessary for electric furnace work,* and coal may cost \$6 or \$8, while furnace coke might cost even more than that. Under such conditions the cost of electrical heat would be less than twice that of coal heat, and would approximate to the cost of heat furnished by good furnace coke.

It might appear from these figures, that electrical heating could not be profitably employed, except under the most extreme conditions of cheap power and dear fuel, but it should be remembered that in an electric furnace, a large proportion of the heat supplied is actually utilized in heating the materials in the furnace, while in a coal-fired furnace this is not always the case, and often, particularly in high temperature furnaces, the greater part of the heat is wasted, and only a small proportion is actually utilized.

The **efficiency** of a furnace may be determined by finding what proportion of the heat value of the coal or the electrical energy supplied, is actually utilized in heating the contents of the furnace. The following table† gives typical efficiencies for a number of furnaces.

TABLE II.

Net Efficiencies of Furnaces used for Melting Metals.

	Per Cent.
Crucible steel furnaces, fired with coke	2-3
Reverberatory furnaces for melting metals	10-15
Regenerative open-hearth steel furnaces	20-30
Shaft furnaces (foundry cupolas, etc.).	30-50
Large electrical furnaces	60-85

*Prof. C. E. Lucke, (Electrochemical Industry, vol. v., p. 230, June, 1907), gives the cost of water-power as \$8.50 to \$25 per K.W. year. Dr. R. S. Hutton, (Electrochemical Industry, vol. v., p. 24, January, 1907), gives figures for cheap water-power, varying from \$20 per H.P. year at Niagara, to \$3 per H.P. year in Norway. Dr. Haanel, (European Report, 1904, p. 32), says he is "credibly informed that the water-power at Chats Falls can be developed at a cost to produce an E.H.P. year at the rate of \$4.50."

†The figures are taken from Prof. J. W. Richards' "Metallurgical Calculations," Part. 1, p. 89.

These efficiencies relate to the melting of metals, but similar figures would be obtained for the same furnaces employed in smelting ores. In the crucible steel furnace and the reverberatory furnace, the greater part of the heat is carried away in the escaping gases, which are necessarily extremely hot; and in the crucible furnace the loss is additionally high on account of the slow transmission of the heat to the steel inside the crucible. In the open-hearth furnace, the loss of heat due to the escaping gases is very much less because the heat they contain is given to the brickwork in the regenerators or checker chambers, and returned from these to the furnace by the incoming gas and air. In shaft furnaces the heat of the furnace gases is largely absorbed by the solid materials in the upper part of the furnace, and by them returned to the zone of fusion. When metals are melted in the electric furnace, no gases need be produced, and thus a large waste of heat is entirely avoided; while the furnace gases produced in the electric smelting of ores are very much less in amount than those from similar coal or gas-fired furnaces. The amount of air that passes through most furnaces, in excess of that required to burn the fuel, increases the loss of heat by the furnace gases; and the incomplete combustion of the fuel is another serious source of loss in some furnaces. The large loss of heat by conduction and radiation from the furnace, is common to fuel and electric furnaces, and depends mainly upon the size and temperature of the furnace; the larger furnaces having, of course, a smaller relative loss.

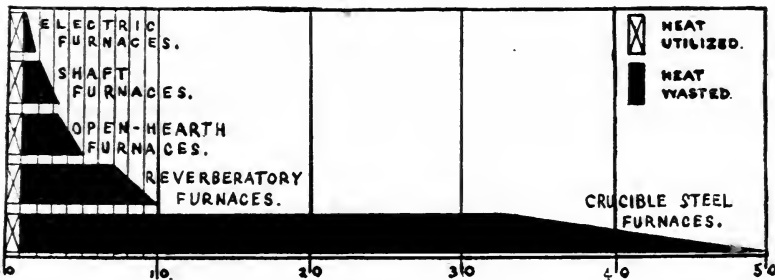

Fig. 20.—Losses of Heat in Melting Metals.

Fig. 20 has been arranged to show, for each class of furnace, the heat equivalent of fuel or electrical energy needed to impart unit quantity of heat to the metal to be melted. The black areas

indicate the loss of heat, the upper edge of each area showing the minimum, and the lower edge, the maximum loss for each class of furnace. The diagram also shows that for one heat equivalent supplied to an electric furnace; a shaft furnace would require nearly two; an open-hearth furnace three; a reverberatory furnace six; and a crucible steel furnace thirty heat equivalents of fuel, in order to melt the same amount of metal.

If these numbers are used to multiply the cost of a ton of the coal or coke used, assuming it to be of about 14,000 B.T.U., the resulting prices may be compared with the cost of $1\frac{1}{3}$ E. H. P. years, and will give an idea whether coal or electrical heating would be cheaper in any particular case. Thus in making crucible steel with furnace coke at \$5 and the E. H. P. year at \$30, the coke used would cost $\$5 \times 30 = \150 , and the electrical energy would cost $\$30 \times 1\frac{1}{3} = \40 , thus making a good case for the electrical production of crucible steel. In the case of the open-hearth furnace, electrical energy at \$10 an E.H.P. year would cost a little more than coal at \$4 a ton, while it would correspond with coke at \$6 to \$7 a ton in a shaft furnace.*

These numbers are based on the mean of the figures given by Prof. Richards for the usual efficiencies of certain classes of furnaces; and in any selected case it would be desirable to have the efficiencies of the particular electrical and fuel furnaces to be compared. The incidental expenses connected with each method of smelting should also be considered.

The results do, nevertheless, give a fair idea of the conditions under which electrical heat could commercially replace fuel heat. They show clearly, that in the production of crucible steel, electrical power should be able to replace coke as a source of heat. The writer pointed out, more than three years ago,† that the production of crucible steel in the electric furnace was technically and financially possible, and plants are now in operation or construction in Sweden, Germany, England, the United States, Canada, and elsewhere.

In comparing the cost of electrical and fuel heating, it has been assumed that the full heat value was obtained from the electrical horse-power year. To obtain this, it would be necessary for the furnaces to be operated at their full load for every

*See also editorial "Electric Heat versus Heat from Fuel," *Electrochemical Industry*, vol. v., p. 298.

†Stansfield, *The Electrothermic Production of Iron and Steel*, *Trans. Can. Soc. of Civil Engineers*, vol. xviii., Part 1, (1910), p. 72.

minute of the year, and any shut-down, or any period during which a smaller amount of power was being utilized, would lessen the useful effect, without any corresponding reduction in the amount paid for the power; as it is bought by the year, and not by the total kilowatt-hours consumed. In the case of fuel-fired furnaces, a shut-down, or a period of reduced output, will increase the working cost per ton of product; but not to the same extent, as the fuel is usually bought by the ton, and not on some assumed standard of maximum consumption. The time during which a single electric furnace is shut down for repairs will necessarily increase decidedly the working cost of electrical energy; but when electric smelting has become well established, the losses in this way will not be heavy. In the regular operation of an electric smelting plant, there will be few accidental shut-downs, all working furnaces will be kept at a steady load, and, by means of spare furnaces, the full load will be maintained during the periodical lay-off of each furnace for repairs.

Having now considered, in a general manner, the efficiency of furnaces and the relative costs of electrical and fuel heating, the method of calculating these efficiencies may be discussed.

The Calculation of Furnace Efficiencies.*

The word heat is used popularly in two senses; thus "the heat of a furnace," meaning how hot the furnace is, is quite distinct from the amount of heat produced in the furnace per minute, or the amount of heat needed to turn a pound of ice into a pound of water. The first use is really a quality of the hot body, and to avoid confusion the word temperature should be used in such cases, while the word heat should be restricted to the second case, in which the quantity of heat is referred to. A definite quantity of heat can be supplied at a high or a low temperature, just as a definite quantity of air can be supplied at a high or a low pressure; and the addition of heat to a body raises the temperature, just in the same way that pumping air into a receiver raises the pressure.

Temperatures are measured, as is well known, by thermometers or pyrometers (the latter for high temperatures), and the scales of these instruments are based upon the temperatures of melting ice and boiling water, these being 0° and 100° on the Centigrade scale, and 32° and 212° on the Fahrenheit scale. The use of these two scales complicates technical literature, since the

*For a full account, with examples, of the calculation of furnace efficiencies, see Prof. J. W. Richards' "Metallurgical Calculations," Parts I., II., and III.

Centigrade is mainly used for scientific purposes, while the Fahrenheit is mainly used for ordinary affairs, and it is often necessary to state temperatures on both scales in order to be generally understood. The conversion from one scale to the other is simple if it is remembered that the temperatures 0°C . and 100°C . are the same as 32°F . and 212°F ., and that 5° difference of temperature on the Centigrade scale correspond to 9° difference of temperature on the Fahrenheit scale; whence $\text{F.}^{\circ} = 1.8\text{C}^{\circ} + 32$; and $\text{C.}^{\circ} = \frac{5}{9}(\text{F.}^{\circ} - 32)$.

Heat is measured in several different units, thus further complicating technical writings, most of these units representing the amount of heat needed to raise the temperature of unit weight of water through 1° . By selecting different weights of water, as the pound, gram, or kilogram, and different temperature scales, it is easy to get six or eight different units of heat, thus entailing a large amount of trouble, both in the statement of amounts of heat and in changing these from one system of units to another.

The following heat units are usually used:—

The Gram-calorie.—(1 cal.)—The amount of heat needed to raise the temperature of one gram of water 1°C . (from 0°C . to 1°C .)*

The Kilogram-Calorie.—(1 Cal.)—The amount of heat needed to raise the temperature of one kilogram of water 1°C .

The Pound-Calorie.—(1 Calb.)—The amount of heat needed to raise the temperature of one pound of water 1°C .

The British Thermal Unit.—(1 B. T. U.)—The amount of heat needed to raise the temperature of one pound of water 1°F . (from 60°F . to 61°F .)*

The Evaporative Unit.—The amount of heat needed to convert one pound of water at 212°F . into steam at the same temperature (at normal atmospheric pressure).

*The value of the gram calorie depends upon the specific heat of water between 0°C . and 1°C ., and that of the B.T.U. on its specific heat between 60°F . and 61°F . Recent determinations, (H. T. Barnes. The mechanical equivalent of heat measured by electrical means, Int. Elect. Congress, St. Louis, 1904, p. 65), show that the specific heat at 0°C . is about 1 per cent. greater than at 60°F . This would mean that in converting pound calories into B.T. Units by the factor $9/5$ an error of about 1 per cent. would be made. Also as the measurement of heat is usually conducted between 15°C and 20°C ., a considerable correction will have to be made to reduce the results to calories as measured at 0°C . For these and other reasons it has been suggested that the calorie should be based on the mean specific heat of water from 0°C . to 100°C . This value is practically the same as if measured at 15°C ., or at 60°F . The mechanical equivalent of one gram calorie of heat measured at 15°C . is about 4.184 joules, making the heat value of 1 kilowatt second, 0.239 Cals., or 0.527 Calb.

The following are the relations between these different units:

1 Kilogram-Calorie*	= 1,000 Gram-calories.
1 Pound-Calorie	= 453.6 Gram-calories.
1 British Thermal Unit	= 5/9 of a Pound-Calorie.
1 " " "	= 252 Gram-calories.
1 Evaporative Unit	= 967 British Thermal Units.

The gram and kilogram-calories are the most convenient for scientific investigations, but in cases where the weights are given in pounds the pound-calorie or the B.T.U. must usually be employed.

* **The efficiency of a furnace** is the ratio between the amount of heat usefully employed in the furnace and the heat value of the fuel or electrical energy supplied: thus, if 100 pounds of steel can be melted in a crucible furnace by the use of 150 pounds of coke, and if 300 pound-calories are needed to melt one pound of steel (this having been determined by experiment), and if one pound of coke can furnish 7,200 pound-calories (found by experiment), the efficiency of the furnace can at once be obtained.

$$\text{Efficiency} = \frac{\text{Weight of steel} \times \text{heat needed to melt 1 lb. steel.}}{\text{Weight of coke} \times \text{heat furnished by 1 lb. coke.}}$$

$$\text{Efficiency} = \frac{100 \text{ lbs.} \times 300 \text{ Calb.}}{150 \text{ lbs.} \times 7,200 \text{ Calb.}} = 0.028 = 2.8\%$$

The statement that 300 pound-calories are needed to melt one pound of steel, means, that if to one pound of cold steel there could be added 300 pound-calories of heat, without any of the heat being lost, the steel would be heated to its melting point and melted. It is, of course, impossible to do this, but by pouring

*In order to distinguish between the kilogram calorie and the gram calorie it is usual to use a C for the first, and a c for the second, thus 100 kilogram calories would be written 100 Cal., and 100 gram calories would be 100 cal. Prof. Richards suggests (private communication) that the same rule should be followed with pound calories and ounce calories (if such should ever be needed). These would be written 100 lb. Cal. and 100 oz. cal. As long as the lb. or oz. is specified the large or small c are only useful for analogy, and the lb. could not be omitted without confusion with kilo Cal. The author suggests the contraction Calb., for pound-calories.

some molten steel into a vessel of water, and noting the rise of temperature of the water, the number of calories given out by the steel in cooling can be determined, and this is obviously the same as the amount of heat needed to melt the steel. The number of calories being equal to the product of the weight of water and its rise of temperature, corrections being made for the heat absorbed by the vessel and otherwise lost during the experiment.

The amount of heat needed to melt one pound of each of the common metals, and the temperature at which they melt, are given in the following table; the figures have all been obtained by experiment, with the exception of the heat of fusion of wrought iron, which has been calculated:—

TABLE III.

Melting Temperatures of Metals, and Amounts of Heat Required to Melt Them.

Metal.	Melting Temperature		Heat to melt 1 lb.	
	C.*	F.	Calb.†	B.T.U.
Tin	232°	450°	28	51
Lead	327°	620°	16	28
Zinc	419°	786°	68	122
Aluminium	657°	1214°	258	465
Brass (65% copper).....	920°	1688°	130	234
Copper	1084°	1983°	162	292
Cast iron † (white).....	1027°-1135°	1880°-2075°		
“ “ (gray)	1100°-1275°	2012°-2327°	245	441
Tool steel (1% carbon)...	1425°	2600°	300	540
Wrought iron or “dead soft” steel	1503°	2737°	343	617

The figures in the last two columns really represent the amount of heat given out by one pound of the metal in cooling

*Melting temperatures of pure metals as given by Dr. J. A. Harker. The figure for copper, 1,084°C., is its melting temperature when protected from oxidation, by a cover of charcoal for example. Oxidized copper melts at 1,062°C.

†These figures are mainly from Richards' "Metallurgical Calculations."

‡Melting temperatures of Cast Iron were determined by Prof. H. M. Howe, see his Metallurgical Laboratory Notes, p. 125.

from the molten state to 32°F . In heating the metal from 60° or 70°F . rather less heat will be needed, but on the other hand, some additional heat will be required in order that the metal shall be thoroughly melted, and the heat actually needed to heat the metal to a casting temperature will be a little more than the figures in the table.

The amount of heat that can be produced from one pound of coke, can be determined by burning a small weighed quantity of the coke in a calorimeter; which is an instrument for measuring the amount of heat that is produced. The amount of heat produced by unit weight of a fuel, is known as its calorific power, and is usually measured in the corresponding heat units; that is, heat units containing the same unit of weight; as, for example, the number of gram calories produced by one gram of fuel; the number of pound calories produced by one pound of fuel, or the number of B.T.U. produced by one pound of fuel. The first two of these results will obviously be identical, and may be called the Centigrade calorific power, while the last result will be $9/5$ times as large, and may be called the Fahrenheit calorific power. Thus the calorific power of carbon is 8,100 on the Centigrade scale, and 14,580 on the Fahrenheit scale, meaning that one part by weight of carbon would give out as much heat, if completely burnt, as would raise the temperature of 8,100 parts of water 1°C ., or 14,580 parts of water 1°F ., so the result is the same, whatever unit of weight is selected. When, however, the fuel is measured by volume, as in the case of a gas, it will be necessary to state the calorific power as so many B.T.U. per cubic foot, or calories per cubic foot, or per cubic meter. Calorific powers are also sometimes stated in evaporative units, thus avoiding the use of either scale of temperature.

In many furnaces the carbon in the fuel is not burnt completely, and it then has a smaller effective calorific power. The complete combustion of carbon produces the gas CO_2 , containing two atoms of oxygen, while its incomplete combustion produces the gas CO , containing only one atom of oxygen. The calorific power in the latter case being only 2,430C., or 4,374F., which is less than one-third of its calorific power when burnt completely. The iron blast-furnace furnishes a good example of this loss of heat through the imperfect combustion of the coke. In order to thoroughly reduce the iron ore to metal a large amount of coke must be present in the furnace, and this can only be burnt to CO in the lower part of the furnace, thus obtaining far less heat from the same weight of coke than if it could be burnt completely to

CO₂. The CO produced in the lower part of the furnace is, however, partly utilized, higher up, for the reduction of the iron ore, and the CO that finally escapes from the furnace is employed as a fuel for heating the blast and for raising steam.

In determining the calorific power of a fuel in a calorimeter, the aqueous vapor resulting from the burning of any hydrogen in the fuel, and any moisture and "combined water" in the fuel, will be condensed to water; and its latent heat of condensation will be included in the resulting calorific power. When the fuel is burnt in any metallurgical furnace, the furnace gases escape at too high a temperature to allow of the condensation of the vapor, and in calculating furnace efficiencies a calorific power should be used which does not include the heat of condensation of the water vapour, since this heat can never be obtained in the furnace. The observed calorific power should, therefore, be corrected by subtracting from it the heat of condensation of all the water vapor that is present in the fuel, or is produced by its combustion. The corrected value has been called the Metallurgical or Practical Calorific Power,* and should be used in the case of all furnaces from which the water, contained in the furnace gases, escapes in the form of vapour.

The following table contains the Metallurgical Calorific Powers of some of the commoner fuels, and some pure substances. The calorific powers of fuels cannot, however, be stated exactly, as they vary considerably.

The figures in this table are, in many cases lower than the calorific powers obtained experimentally in a calorimeter, the difference being the correction of 606.5 pound-calories per pound of water in the products of combustion; this amount of heat being needed to evaporate a pound of water at 0°C. In calculating furnace efficiencies by means of this table, the furnace will thus be debited with the sensible heat carried by the water vapour as well as with that carried by the other furnace gases, but the heat of condensation of the water vapour will have been removed from the balance sheet.

*Prof. J. W. Richards' loc. cit.

TABLE IV.

Calorific Powers.

(All water remaining uncondensed.)

	C. Calb.*	F. B.T.U.†
Carbon (burnt to CO ₂), per lb.	8,100	14,580
“ “ “ CO “ “	2,430	4,374
Carbon monoxide “ “	2,430	4,374
Carbon monoxide . . . per cu. ft.	191	344
Hydrogen per lb.	29,030	52,254
“ “ “ “ per cu. ft.	163	293.5
Methane (Marsh gas, CH ₄ .) “ “ “	537	966
Ethylene (Olefiant gas, C ₂ H ₄ .) “ “ “	904	1,627
Wood (air dried), per lb.	about 3,000	about 5,400
Peat “ “ “ “ “ “	3,000- 4,000	5,400- 7,200
Charcoal (5 to 10 per cent. moisture) per lb.	7,000- 7,500	12,500-13,500
Oven coke “ “	6,900- 7,400	12,400-13,300
Anthracite “ “	6,500- 7,500	11,500-13,500
Bituminous coal	7,000- 8,000	12,500-14,500
Fuel oil “ “	9,500-11,000	17,000-20,000
Natural gas per cu. ft.	460- 540	830- 970
Coal gas “ “ “	300- 360	550- 650
Water gas “ “ “	140- 180	250- 320
Producer gas “ “ “	55- 90	100- 160
Electrical energy, per kilowatt hour‡	1,897	3,415
Electrical energy, per E.H.P. hour	1,415	2,547
Electrical energy, per E.H.P. year of 8,766 hours	12,400,000	22,320,000

*The values for pure substances in this column are those adopted by Prof. Richards.

†These values are obtained by multiplying the figures in the previous column by the factor 9/5.

‡The values for electrical energy have been calculated in terms of the specific heat of water at 15°C., 1 kilowatt-second being 0.239 Cal., or 0.527 Calb.

The calorific powers of the pure substances, forming the first part of the table, will serve as data for calculating the calorific power of a gaseous fuel of known composition, and will enable approximate figures to be obtained for solid and liquid fuels. The coal and other solid fuels in the lower part of the table are supposed to be in the condition in which they would naturally occur: the wood being air dried, and containing some 20 to 25 per cent. of moisture, the peat also air dried and retaining 20 to 30 per cent. of moisture; the charcoal, coke and coal have the usual amounts of ash and moisture. The figures given for coal and other fuels will not cover all cases, but are intended to represent the ordinary run of fuels. The calorific powers of gases, per cubic foot, correspond to dry gas at 32°F. , and would be about 5 per cent. less at 60°F. , and 7 per cent. less at 70°F. on account of the increase in volume of the gas: the presence of moisture would still further decrease the calorific power.

By the aid of Tables III. and IV. it will be easy to obtain, approximately, the percentage efficiency of any furnace, whether fired by solid, liquid, or gaseous fuel, or heated electrically—if it is employed for heating and melting metals, and if the amount of fuel or electrical energy corresponding to the melting of a certain weight of metal is known. It will not be possible, however, to calculate in the same manner the efficiency of a furnace, such as an open-hearth steel furnace, in which the metal is kept molten for some hours in order to allow of certain changes being made in its composition. In such a furnace the efficiency can only be calculated in reference to the time during which the charge was being heated. During the remainder of the “heat” the furnace may remain for considerable periods without any marked rise of temperature, although fuel is constantly being used; thus making the calculated efficiency zero during such periods.

The efficiencies of metal-melting furnaces were first considered on account of the simplicity of the calculation. But it is equally possible to calculate the efficiency of a blast furnace, or an electrical ore-smelting furnace, in which the heat is used, not merely in melting a metal, but also in effecting the chemical work of reducing the ore to a metallic condition. The amounts of heat necessary for the formation of a large number of chemical compounds are known, and by means of these, it is possible to draw up a balance sheet showing what amount of heat is needed for the chemical reactions, as well as for melting the metal and slag in the furnace. The efficiency can then be calculated as in the simpler cases.

It may be of interest, and practical value, to conclude this chapter by calculating the efficiency of a Heroult electrical steel

furnace, operated at La Praz, France, for the Haanel commission in March, 1904.* The furnace—basic lined, was making steel by melting scrap with ore and lime.

The charge selected for calculation (number 660) consisted of:—

	Lbs.
Steel scrap	5,733
Iron ore	43 ⁰
Lime	34 ⁶

Other additions were made after the charge was melted, but for obtaining the melting efficiency it will only be necessary to consider the operation of melting this charge in the furnace.

The scrap charged had the following composition:—

Carbon	0.110
Silicon	0.152
Sulphur	0.055
Phosphorus	0.220
Manganese	0.130
Arsenic	0.089

Supposing that the iron ore in the charge contained 400 pounds of ferric oxide, it may be assumed, that during the melting of the charge, this was reduced to ferrous oxide by the oxidation of most of the metalloids and some of the iron in the original scrap. A rough calculation shows that the melted charge would consist of about 5,660 pounds of "dead soft" steel, and 850 pounds of slag rich in ferrous oxide and lime, and that the reaction would produce some 24,000 pound-calories, which makes a small addition to the heat furnished by the electric current.

Assuming that a temperature of 1,520°C. is necessary for a complete fusion of the charge (see Table III.), about 344 Calb. will be needed to melt each pound of soft steel, or, in all, $344 \times 5,660 = 1,947,000$ Calb.

The slag will need about 600 Calb. per pound in order to melt and heat it to the same temperature, or, in all, $600 \times 850 = 510,000$ Calb.

The electrical power employed was 215 kilowatts during the first hour, and 342 during the remainder of the run; the current being supplied at about 110 volts. The time occupied in melting

*Report of the Commission appointed to investigate the different electro-thermic processes for the smelting of iron ores and the making of steel in Europe, pp. 54, 55, 71 and 72.

the charge was $5\frac{1}{3}$ hours, and the electrical energy supplied to the furnace during this time was 1,680 kilowatt hours.

The heat supplied by the electric current was:—

$$1,680 \times 1,897 = 3,187,000 \text{ Calb. (See Table IV.)}$$

In the operation of melting the charge the heat utilized may be taken as that needed to melt the steel and the slag, while the heat supplied to the furnace is supplied in part by the electric current, and in part by the reaction between the scrap and the iron ore.

Balance Sheet of Heat.

Heat supplied to the furnace :	Calb.
1,680 kilowatt hours of electrical energy	3,187,000
Reaction between steel scrap and iron ore	24,000
	<hr/>
	<hr/>
Total	3,211,000
	<hr/>
Heat utilized in the furnace:—	
To melt 5,660 lbs. of soft steel	1,947,000
To melt 850 lbs. of basic slag	510,000
	<hr/>
Total	2,457,000
	<hr/>
	2,457,000
Efficiency of furnace = $\frac{2,457,000}{3,211,000}$ = 0.765 = 76.5%.	

In making this calculation it has been assumed that no oxidation of the steel scrap took place except by reaction with the iron ore in the charge. Such an assumption would be quite wrong in regard to an open-hearth furnace, where the flame of burning gases constantly plays over the charge, but in the electric furnace the charge is largely protected from the air, and there is consequently less oxidation. If any considerable amount of iron were burnt in this way, the heat produced by its oxidation should have been added, in the balance sheet, to the heat supplied to the furnace; and this would lower the resulting figure for the efficiency.

After the charge was completely melted, the slag was poured off, and the steel further purified by the addition of fresh slags, made of lime, sand and fluor spar. After these were removed, the steel was recarburized in the furnace by additions of "carburite" (a mixture of iron and carbon) and ferro-silicon; some ferro-manganese was also added, and a little aluminium in the ladle.

The yield of ingots was 5,161 lbs. of tool steel of the following composition:—

Carbon	1.016
Silicon	0.103
Sulphur	0.020
Phosphorus	0.009
Manganese	0.150
Arsenic	0.060

Three hours were required for the purification and carburization of the steel, making a total of $8\frac{1}{3}$ hours, and a total consumption of 2,580 kilowatt hours, or 0.171 E.H.P. years per ton of steel ingots. At \$10 per E.H.P. year, the cost of electrical energy for the ton (2,240 lbs.) of tool steel would be \$1.71.

CHAPTER IV.

Electric Furnace Design, Construction and Operation.

An electric furnace consists essentially of some substance R, (Fig. 21), through which an electric current flows, and of an envelope C, which retains the heat and the contents of the furnace. Carbon electrodes, A and B, are usually needed to convey the current in and out of the furnace. If the envelope could be made perfectly heat tight, and if no fresh charge were introduced during the operation, it would be possible to obtain any temperature in R up to the volatilizing point of the contents of the furnace,

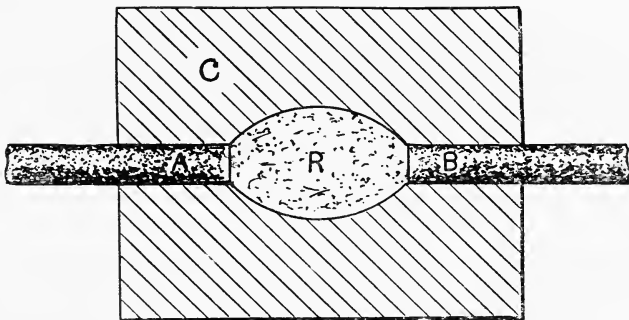

Fig. 21.—Ideal Electric Furnace.

with the smallest electric current, provided it were allowed to pass for a sufficient length of time. With the materials actually available for furnace construction this is not possible. For a definite size and construction of furnace, a definite rate of heat production will be needed in order to attain any particular temperature.

The rate of production of heat is measured by the number of Watts of electrical power supplied to the furnace, and may conveniently be stated in Watts per cubic inch, or Kilowatts per cubic foot of the interior volume of the furnace. The rate of heat production which is necessary to enable a certain temperature to be attained, may be calculated from a consideration of the area, thickness and conductivity for heat of the walls of the furnace; but it is more easily obtained by reference to furnaces of similar construction which have attained definite temperatures with definite consumption of electric power.

The above considerations apply more particularly to an intermittent furnace such as the Moissan, or Stassano furnaces, in which a charge of ore or metal is submitted to the heat of the electric current until it has all been reduced or melted, and the

whole of the furnace and its contents has been heated to a uniform high temperature. In the case of a continuous furnace, such as the Heroult furnace recently employed to smelt iron ores at Sault Ste. Marie, Fig. 29, p. 108, a constant stream of cold material enters the furnace, and after reduction and fusion, is tapped out as molten pig and slag; only a portion of the contents of the furnace being heated at any one time to the smelting temperature. In such a furnace the temperature attainable is limited by the melting temperature of the charge; any increase in the rate of heat supply will serve mainly to increase the rate of smelting, without materially increasing the temperature of the furnace. It is like melting ice in a pail, the ice melts faster on a hot day than on a cool one, but the water surrounding the ice will not become warm as long as there is any ice left to melt. Even in such a furnace each portion of the charge must ultimately be heated to the smelting temperature, and a definite rate of heat supply is needed if the furnace is to smelt at all.

Materials of Furnace Construction.

The materials for constructing the interior of electric and other furnaces, should be infusible at the temperature of the furnace; should resist the action of the metallic slags or other contents of the furnace; should retain the heat of the furnace as far as possible, and should be capable of being formed into bricks, or coherent linings which will resist the mechanical action of the charge in the furnace. The following are a number of the more important materials that can be employed.

Fireclay Bricks.* The clay from which these are made consists of pure clay, or kaolin, Al_2O_3 , $2SiO_2$, $2H_2O$, with a variable proportion of silica in addition to the amount present in the kaolin, and as little as possible of fluxing materials such as iron oxide, lime, magnesia, potash or soda. Even silica lowers the melting point, and should be present only in moderate amount. These bricks are largely used for lining ordinary metallurgical furnaces, but are not usually sufficiently refractory for electric furnaces; they

*Notes on the New Jersey Fire-Brick Industry, H. Ries. Amer. Inst. Mining Engineers, vol. xxxiv., (1904), p. 254.

Refractoriness of Some American Fire-Brick. R. F. Weber, Amer. Inst. Mining Engineers, vol. xxxv., p. 637.

The Fire-Clays of Missouri. H. A. Wheeler, Amer. Inst. Mining Engineers, vol. xxxv., p. 720.

Determination of the Refractoriness of Fire-Clays. H. O. Hofman & C. D. Demond, Amer. Inst. Mining Engineers, vol. xxiv., p. 42; vol. xxv., p. 3; vol. xxviii., p. 435.

A. H. Sexton, "Fuel and Refractory Materials," (textbook).

can, however, be used as a backing for more refractory material. Being silicious in composition, they are easily fluxed by slags containing metallic oxides. When not exposed to such slags they will stand temperatures up to $1,400^{\circ}\text{C}$.— $1,800^{\circ}\text{C}$., or $2,500^{\circ}\text{F}$.— $3,300^{\circ}\text{F}$. They should be laid in fireclay mud, instead of lime mortar, as the latter would crumble away if strongly heated. Fireclay bricks are subject to a considerable shrinkage when fired. This shrinkage is permanent and varies in amount with the temperature to which the bricks have been heated. Subsequent heating and cooling, at lower temperatures, causes a small temporary expansion and contraction of the brick.

Silica Bricks.* These should contain about 95% to 97% of silica, SiO_2 . The melting temperature of silica is a little above that of platinum, being about $1,830^{\circ}\text{C}$., or $3,330^{\circ}\text{F}$.,† and the silica brick should stand up to about $1,750^{\circ}\text{C}$., or $3,180^{\circ}\text{F}$. They are useful for the roof and other parts of open-hearth steel furnaces, that are exposed to a very high temperature, but not subjected to the action of metallic slags which would soon flux them away. They have the property of expanding when fired, and their expansion and contraction when subsequently heated and cooled is greater than that of fireclay bricks. Silica bricks should be laid in a silicious mud for mortar, and in general, all refractory bricks should be laid in mortar of the same composition as the brick, to avoid fluxing; thus it would not do to lay basic brick in silicious mortar, as the mortar would combine with and flux part of the brick.

Lime, CaO .‡ This is an extremely refractory material, and is useful for lining small electric furnaces. Its melting temperature is not exactly known, but may be about $2,050^{\circ}\text{C}$., or $3,700^{\circ}\text{F}$.§ Lime is obtained by burning limestone, (CaO , CO_2), thus driving off the carbon dioxide which it contains. Burnt lime absorbs moisture from the air and slakes, forming the hydroxide CaO , H_2O . Lime mortar contains water and carbon dioxide, and

*A. H. Sexton. "Fuel and Refractory Materials," p. 323.

†O. Boudouard, finds the melting temperature of pure silica to be $1,830^{\circ}\text{C}$. Journ. Iron & Steel Inst., vol. 1905, No. 1, p. 350.

A. Lampen, finds the melting temperature of pure quartz to be $1,700^{\circ}\text{C}$. Journ. Amer. Chem. Soc., vol. xxviii., p. 852.

A. Stansfield found pure silica to be rather less fusible than platinum, say, $1,800^{\circ}\text{C}$., (determination about 1892, unpublished).

‡A. H. Sexton. "Fuel and Refractory Materials," p. 317.

§O. Boudouard, "The Electric Furnace."

§O. Boudouard, loc. cit. apparently assumes the melting temperature of lime to be about $2,050^{\circ}\text{C}$.

when it is heated in a furnace, these are driven off, and the mortar crumbles away. Lime cannot be made into fire bricks by mixing it with water, as the bricks would crumble in the furnace, and it is difficult to render lime coherent by the use of any other material. This difficulty of binding and liability to slake has prevented the general use of lime for furnace linings. Small electric and oxy-hydrogen furnaces may be constructed of blocks of quick-lime or of the natural limestone which becomes converted internally into lime during the operation of the furnace. Being basic or non-silicious in character, lime will resist the action of metallic slags, and it would form a valuable material for lining electric and other furnaces if it were not for the objections already mentioned. The use of lime in the electric furnace is also limited by its property of forming a fusible carbide when heated with carbon.

Magnesia.* Burnt Magnesite, Magnesite Bricks, MgO. Magnesia is even more refractory than lime, melting at perhaps $2,100^{\circ}\text{C.}$, or $3,800^{\circ}\text{F.}$ It is produced by burning magnesite (MgO, CO_2), thus driving off the carbon dioxide, in the same way that lime is produced from limestone. Although it resembles lime chemically, magnesia does not slake very easily, and when strongly burned it shrinks considerably, forming a heavy material very different from the light, chemically prepared magnesia which is used as a medicine. The shrunk magnesia can be cemented together to form a moderately strong fire-brick, which is extremely valuable for lining basic open-hearth furnaces and electric furnaces.† It is not easily fluxed by metallic slags, since it is basic in composition. On account of their great compactness (a brick weighs about $8\frac{1}{2}$ lbs.), they are very good conductors of heat, being about twice as good as fire-clay bricks, and in constructing electric furnaces of magnesite bricks an outer coating of some other material should be used to diminish the loss of heat, except when this cooling is desired to prevent the fluxing of the walls. Magnesite bricks are liable to crack under the influence of heat unless it is gradually applied. Their property of contracting when heated renders them unsuitable for building the arched roofs of furnaces, and silica bricks would be used for this purpose except in furnaces where the roof was exposed to a temperature at which they would melt. Furnace linings may also be constructed of burnt magnesite in the form of a powder; it is mixed with tar or pitch to make it

*A. H. Sexton. "Fuel and Refractory Materials," p. 325.

†A. Lampen, loc. cit. gives the melting temperature of fused magnesia as $2,000^{\circ}\text{C.}$, and that of magnesia brick with high percentage iron as $1,900^{\circ}\text{C.}$ to $2,000^{\circ}\text{C.}$

bind, and rammed into place around a core by means of a hot iron rod. Magnesia does not combine with carbon to form a carbide, and on this account its use in the electric furnace is preferable to that of lime. Electrically fused magnesia has recently been obtained, and forms a very compact and refractory material for lining electric furnaces, or it may be applied as a paste mixed with silicate of soda to render ordinary fire-clay bricks more refractory.*

Dolomite. This is a limestone containing a considerable proportion of magnesite, and when burnt it forms a valuable refractory material, which, like burnt magnesite, may be employed as a powder, or in the form of bricks. It resembles magnesite, but is not quite so good.

In furnaces constructed partly of silica bricks, and partly of dolomite, or magnesite bricks, it would be expected that they would flux one another at the line of contact. On this account, a course of chromite brick is sometimes introduced as a parting layer between the two, as this brick, itself very refractory, does not easily flux with either acid (siliceous) or basic materials. When magnesite bricks are used, however, it is found that this precaution is unnecessary.

Alumina, Al_2O_3 .† This is prepared from the mineral bauxite ($Al_2O_3, 2H_2O$), which is also the source of the metal aluminium. Bauxite has long been used as a lining for furnaces and recent attempts at purification with a view to improving it for use as a refractory material, have been successful; and the purified, calcined bauxite bonded with a little fire clay, sodium silicate, or lime, makes an excellent brick; which appears to be as good as magnesite brick for use in the basic open-hearth furnace. It is also said to be a good lining for rotary Portland cement kilns, and for lining lead refining furnaces, where they are exposed to the fluxing action of corrosive lead slags. Alumina is classed as a basic material, like magnesia or dolomite, and its melting temperature is about $2,100^{\circ}C$.‡

Carbon. (Coke, Charcoal, Graphite). Carbon is the most refractory substance known; it has never been melted, but softens and volatilizes at the temperature of the electric arc, that is about

*Electrically-shrunk magnesia, see paper by E. K. Scott, quoted *Electrochemical Industry*, vol. iii. (1905), p. 140.

†A. H. Sexton. "Fuel and Refractory Materials," p. 319.

‡J. W. Richards, "Metallurgical Calculations," vol. i., p. 95, gives the melting point of alumina as about $2,200^{\circ}C$.

O. Boudouard, loc. cit. gives data which point to about $2,100^{\circ}C$. as the melting temperature of alumina.

3,700°C., or 6,700°F.* In its more compact forms it is a fair conductor of electricity and of heat, the former quality together with its infusibility enabling it to be used for electrodes to lead the current into electric furnaces. Being combustible it is liable to waste away when exposed to the air at a red heat, and for the same reason it is corroded when exposed to slags that contain easily reducible metallic oxides. Carbon exists in the three different forms of amorphous carbon, graphite and diamond; charcoal, coke and the other common forms of carbon being of the amorphous variety. When amorphous carbon, or the diamond are heated to the temperature of the electric arc, they are changed into graphite. Carbon blocks composed of coke or graphite can be used for lining furnaces, provided they are not exposed to air or to oxidising slags, but carbon has not been much used for metallurgical furnace linings. In the electric furnace it is often employed, forming a lining which also serves as an electrode, as in the Heroult iron smelting furnace, (Fig. 29, p. 108), the aluminium furnace, (Fig. 5, p. 7), and the Willson carbide furnace, (Fig. 7, p. 10); but it cannot usually be employed for the entire lining, because it is so good a conductor of electricity that the current would tend to be short-circuited by the lining instead of passing through the charge or resistor in the furnace. Coke powder can be used for lining parts of furnaces, using pitch or tar as a binder, and such linings will conduct the electric current and may be used as electrodes. In experimental work a lining of charcoal powder cemented with molasses and water may sometimes be used, and has the advantage that it retains the heat of the furnace very well, and being a poor electrical conductor, it can be used for the entire lining without fear of short-circuiting the current. If exposed to the air, however, it will burn up completely if it once reaches a red heat. Graphite is a better conductor of electricity and of heat than amorphous carbon, and is less easily oxidised by air or metallic slags; hence, electrodes are often composed of it. Graphite is often used in the construction of crucibles, the graphite being mixed with its own weight of fire-clay. The graphite renders the fire-clay refractory, and the

*The temperature of the positive carbon of the electric arc was determined by Violle to be 3,500°C., and he modified this figure later to 3,600°C. (Wright, *Electric Furnaces*, p. 9). Le Chatelier obtained the figure 4,100°C. by his optical pyrometer (Le Chatelier & Boudouard *High Temperature Measurements*, p. 155). Lummer, by a radiation method gives the temperature as between 3,500°C. and 3,900°C. (Le Chatelier & Boudouard, p. 212). Fery has obtained the values 3,490°C., 3,869°C., and 3,897°C. by different optical methods, (Wright, p. 277). The value 3,700°C. is adopted by Richards (*Metallurgical Calculations*, vol. i, p. 62), as the "boiling point" of carbon.

fire-clay protects the graphite from oxidation. These crucibles are not so refractory as the graphite alone would be, and for electric furnace experiments, crucibles may be cut out of a block of graphite or retort carbon.

For lining electric furnaces, when carbon is undesirable, some products of the electric furnace itself are very suitable. They are not so refractory as carbon, but are more refractory than the other furnace materials such as magnesia, silica, lime or alumina.

Carborundum.* This is produced by heating silica and carbon to a very high temperature in the electric furnace. It is a crystallized compound of silicon and carbon having the formula SiC , and besides being valuable as an abrasive, it forms a very refractory furnace lining. The carborundum powder can be made to cohere by the use of fire-clay (6 parts of the powder to 1 of fire-clay), or, by a solution of silicate of soda, or water glass, which should be very dilute if the highest temperatures are to be reached, as the silicate of soda makes the carborundum less refractory. Tar or glue can also be used as binding materials, and a very strong brick can be obtained by using glue as a temporary cement and exposing the moulded article to an oxidizing atmosphere at a high temperature for some hours, when the partial oxidation of the carborundum furnishes silica which acts as a permanent bond.

Carborundum Fire-Sand. This is a name applied to the uncrystallized variety of carborundum, which is found in the cooler parts of the carborundum furnace. It only differs from carborundum in not being crystallized, and can be used in the same manner as a refractory material.

Siloxicon.† This is made in the same manner as carborundum, but less carbon is used in the charge, with the result that the silica is not completely reduced, and the resulting substance retains some oxygen. The composition is not constant, as a series of compounds are formed, but a typical formula is $\text{Si}_2\text{C}_2\text{O}$. This

*The Carborundum Furnace, F. A. J. FitzGerald, *Electrochemical Industry*, vol. iv., (1906), p. 53.

The Electrochemical Industries of Niagara Falls, F. A. J. FitzGerald, *Electrochemical Industry*, vol. iii., p. 253.

Refractory Materials in Electrical Resistance Furnaces, F. A. J. FitzGerald, *Electrochemical Industry*, vol. ii., (1904), p. 439.

Refractory Materials for Furnace Linings, E. K. Scott, *Electrochemical Industry*, vol. iii., (1905), p. 140.

†Oxidation of Siloxicon, E. G. Acheson, *Electrochemical Industry*, vol. i., p. 373.
Siloxicon Brick, *Electrochemical Industry*, vol. i., pp. 287 and 373; vol. ii., p. 442; vol. iii., p. 445; vol. iv., p. 40.

forms a refractory material for lining furnaces, and may be made to cohere by grinding it to powder, moistening the powder with water, pressing it into a mould, and strongly firing the moulded material. The firing probably oxidizes the siloxicon grains superficially, forming silica which acts as a bond. Siloxicon is said to be unaffected by acid or basic slags, and to be undissolved by molten iron, but although this may be true at moderate furnace temperatures it can scarcely hold at the higher temperatures of the electric furnace.

The silicon carbides, although very refractory, are slowly oxidized at high temperatures in the presence of air; siloxicon oxidizing when heated above $1,470^{\circ}\text{C}$., or $2,674^{\circ}\text{F}$. Carborundum was, for a long time thought to be unoxidizable, but it has been found to oxidize slowly at high temperatures.

These substances are far less refractory than carbon, being dissociated into graphite and silicon vapour at high electric furnace temperatures.* They can be used in some forms of electric furnace as a layer protecting some less refractory material such as fire-clay or magnesite bricks, and applied as a paint mixed with silicate of soda they improve very materially the lasting qualities of fire-clay bricks in ordinary metallurgical furnaces.

TABLE V.
Refractory Materials.

Material.	Melting Temperature.	
Fire-clay brick. Kaolin with additional silica	$1,400^{\circ}\text{C}$.	$2,550^{\circ}\text{F}$.
	to	to
	$1,800^{\circ}\text{C}$.	$3,270^{\circ}\text{F}$.
Silica brick. Silica with binding material..	$1,700^{\circ}\text{C}$.	$3,100^{\circ}\text{F}$.
	to	to
	$1,800^{\circ}\text{C}$.	$3,270^{\circ}\text{F}$.
Silica (pure)	$1,830^{\circ}\text{C}$.	$3,330^{\circ}\text{F}$.
Lime (pure)	about $2,040^{\circ}\text{C}$.	$3,700^{\circ}\text{F}$.
Magnesia brick	" $2,000^{\circ}\text{C}$.	$3,600^{\circ}\text{F}$.
Bauxite brick	" $2,000^{\circ}\text{C}$.	$3,600^{\circ}\text{F}$.
Magnesia (pure)	" $2,100^{\circ}\text{C}$.	$3,800^{\circ}\text{F}$.
Alumina (pure)	" $2,100^{\circ}\text{C}$.	$3,800^{\circ}\text{F}$.
Carborundum , SiC.	decomposes $2,220^{\circ}\text{C}$.	$4,000^{\circ}\text{F}$.
Carbon	boils $3,700^{\circ}\text{C}$.	$6,700^{\circ}\text{F}$.

*S. A. Tucker and A. Lampen, Amer. Chem. Soc., vol. xxviii, p. 858, find the dissociation temperature of carborundum to be $2,220^{\circ}\text{C}$.

Note.—Very little reliable information with regard to the melting temperatures of refractory materials is available and the above table must be regarded as an attempt to combine what little there is, in the hope that experimenters may be induced to supply the missing information. With regard to silica, the writer, a number of years ago, found the chemically pure material to be a little more refractory than platinum, say $1,800^{\circ}\text{C}$., while Boudouard has recently stated it to be $1,830^{\circ}\text{C}$.. The data for alumina, lime and magnesia are very confusing; Moissan states that alumina is more fusible than lime, and magnesia less fusible than lime, but other figures given for their melting points give magnesia as $2,000^{\circ}\text{C}$., and alumina as about $2,200^{\circ}\text{C}$., thus completely reversing the order. The figures stated in the table are based upon the conflicting information available. It should be remembered, however, that the melting points of some of these refractory materials, and still more the dissociating points of the silicon carbides may not be sharply defined like the melting points of pure metals, but have, in the former case, a range of increasing softness before true melting occurs, and that this melting temperature is largely affected by the oxidizing or reducing atmosphere in the furnace. Siloxicon has been said to turn into carborundum at $5,000^{\circ}\text{F}$., or $2,760^{\circ}\text{C}$., corborundum fire-sand to crystallize into carborundum at $7,000^{\circ}\text{F}$., or $3,870^{\circ}\text{C}$., and carborundum to be infusible at the same temperature, while it is admitted that these substances are less refractory than carbon, whose boiling point is taken to be $3,700^{\circ}\text{C}$., or $6,700^{\circ}\text{F}$. Recent experiments, however, place the formation temperature of carbide of silicon at $1,600^{\circ}\text{C}$., its crystallization at $1,950^{\circ}\text{C}$., and its decomposition into graphite and silicon vapor at $2,220^{\circ}$.*

In addition to its ability to resist high temperatures and corrosive slags, the power of a furnace lining to retain the heat which is produced in the furnace must be considered. It is rare that good refractory and heat retaining qualities are combined in the same material, and to get the best effect it is usually necessary to adopt a stratified construction, placing refractory materials on the inside, and heat retaining materials outside. Generally speaking the light porous substances are good retainers of heat, while heavy compact bodies are poor heat insulators. Comparatively little information is available with regard to the conductivity of furnace materials for heat, particularly at high temperatures. The following figures are taken from Prof. Richards "Metallurgical Calculations," (vol. 1, p. 183),† to which the reader is referred for further information:—

*S. A. Tucker and A. Lampen, loc. cit.

†See also a paper by Hutton and Beard on Heat Insulation. *Electrical Rev.*, N.Y., July 22nd, 1905, and *Eng. Record*, Nov. 25th, 1905.

TABLE VI.

Heat Conductivities of Furnace Materials.

In Centimeter, Gram, Second, Units.

Fire-clay bricks(0°C.— 500°C.)	0.00140
Fire-clay bricks(0°C.—1,300°C.)	0.00310
Alumina bricks(0°C.— 700°C.)	0.00204
Magnesia bricks(0°C.—1,300°C.)	0.00620
Lime(20°C.— 98°C.)	0.00029
Quartz sand(18°C.— 98°C.)	0.00060
Carborundum sand(18°C.— 98°C.)	0.00050
Fire brick dust(20°C.— 98°C.)	0.00028
Infusorial earth(17°C.— 98°C.)	0.00013
Infusorial earth(0°C.— 650°C.)	0.00038

The figures indicate the number of gram calories of heat that would pass in one second through a centimeter cube of the material, if the hot and cold sides differed in temperature by 1°C. The best conductivity varies with the temperature, being greater at high temperatures, as is shown by the first two and the last two items in the list. The figures represent the mean conductivity for the range of temperature indicated, and were probably obtained by measuring the flow of heat through a wall of definite thickness and area, the two sides of which were maintained at the temperatures mentioned. It will be understood that a material having a high conductivity for heat, as shown in the table, would, if used in the construction of a furnace wall, allow a considerable amount of heat to escape and be wasted. Light powders like infusorial earth are good for retaining the heat in a furnace, but these do not retain their heat insulating qualities at high temperatures and should only be used as an outer jacket to the furnace. Undoubtedly much could be gained in ordinary furnaces by a more careful attention to the heat conducting qualities of the materials of which the walls are composed, and in electric furnaces, where the cost of the heat is usually considerably greater, it is even more important to guard as far as possible against loss. On the other hand cases are common in large fuel-fired furnaces, and occur even in electric heating, where the importance of preserving some portion of the furnace that is exposed to corrosive slags or very high temperatures is greater than the need to save the heat, and in such cases, air cooling, and even water-cooling of the furnace walls may be adopted. It should be remembered that the rate

of loss of heat from a furnace will be proportional to the area of its walls, that is, to the square of the linear dimensions. The ratio of heat loss per unit volume will, therefore, be inversely proportional to the dimensions of the furnace, or a furnace that is twice as large as another (in linear dimensions) will only have half as large a heat loss, for a given volume of the interior of the furnace. This supposes the furnace walls to be of equal thickness in the two furnaces, but in small experimental furnaces the walls are usually thinner than they are in full-sized furnaces, and under these conditions the small furnace fares even worse in proportion; and in the extreme case of a small furnace constructed as an exact model on a scale of one inch to the foot of a large furnace, the heat loss for each cubic inch of the model would be 144 times as great as from the large furnace, provided, of course, that both attained the same temperature. In other words if the furnaces were merely being kept hot, no work being done in them, the small furnace would need 144 times as much heat per cubic inch as the large furnace in order to keep it heated to the same temperature.

In Table VI. the figures in brackets show the temperatures between which the experimental determinations were made, thus in the first line of the table one side of a fire brick may have been kept at 500°C ., and the other side at 0°C ., while the rate at which heat passed through it was determined. The conductivity in the last column is consequently a mean value for the given temperature range, and the actual conductivity of fire-bricks at high temperatures will be even higher than the figure given on the second line. In applying these figures to calculate the losses of heat through furnace walls, it should be remembered that the heat transmitted is proportional to the cross section, that is, the area of the piece of wall considered, inversely proportional to its thickness, and proportional to the difference of temperature between the two sides of the wall. The conditions are in fact just the same as in the flow of electricity in a conductor. By way of comparison with the figures in the table, it may be mentioned that the conductivity for heat of silver is 1.1, of copper 0.9, and of iron 0.2 when cold.*

Furnace walls without refractory materials. The properties of a number of refractory materials have been considered, but it not infrequently happens, in electric furnace construction, that the heat can be developed in the midst of a large mass of the material to be heated; and although a very high temperature may

*Richards' Metallurgical Calculations, vol. i., p. 175.

be reached internally, the exterior never becomes strongly heated, and mere retaining walls, which need not be extremely refractory, can be used. The best known example of this is the Acheson furnace for the production of carborundum (Fig. 8, p. 11). The Willson carbide furnace, (Fig. 7, p. 10), also depends for its preservation upon the unacted on, and relatively cool portions of the charge, as the walls of the crucible are only made of iron. The same principle can be applied in the case of continuous electric smelting furnaces, by constructing the furnace in such a way that the heat is developed within the mass of ore descending in the shaft of the furnace, and by regulating the current so that a portion of the ore will remain unfused around the sides of the furnace. When this can be done, no trouble will be experienced in maintaining the walls for an indefinite period, even when corrosive slags are produced; but this method does not lend itself readily to processes in which the charge must be heated considerably above its melting point, as the hot central portion, being liquid, will mix with the cooler parts round the sides, and will eventually fuse the whole of the protecting layer of ore. The device of restricting the zone of highest temperature to the middle of a furnace depends upon a constant abstraction of heat around the sides. This is usually the result of the air-cooling of the outer walls, but it would be more ideal if the cooling of the walls could be effected by a continual supply of fresh ore, so that the heat would not really be wasted, but would be used in heating the fresh ore. In some cases, however, it is even necessary to water-cool parts of furnaces in order to preserve the walls. As an example of this may be mentioned the De Laval smelting furnace, (Fig. 18, p. 29). This has a dividing partition between the two troughs, B and C, which contain molten metal and serve as electrodes. The partition being entirely within the furnace, will experience very little air-cooling, and the arrangement of the electrodes tends to make the current flow most strongly against it in passing through the slag. The partition will consequently, become very hot at this point, and would certainly dissolve away, if it were not for the cooling effect of the water-jacket J placed within it. As further examples of water-cooling, may be mentioned the water-cooled electrodes in Heroult's electric steel furnace. The electrode is cooled, by a water-jacket, at the point where it passes through the furnace roof, and the part exposed to the air is consequently below a red heat, and does not oxidize as it otherwise would. With this arrangement, a closer joint is maintained around the electrode, the roof is protected from cutting

by the flame issuing from the furnace, and less loss of heat occurs. Another use of water-cooling is in electrolytic furnaces, when the molten electrolyte is contained in an iron vessel, which is required to be gas-tight. Since both the electrodes pass through the walls of the vessel, or the vessel itself may be one electrode, it is necessary to introduce an insulating joint at some point, and this joint must be unaffected by heat, by the electrolyte, or by the gases given off in the operation. A satisfactory method of effecting this, is to make the vessel in two parts, one of which may be the lid, and to maintain, by water-cooling, a layer of solidified electrolyte between the two parts, which are slightly separated. This method is employed in Borchers' appliances for the electrolysis of fused zinc chloride, and for the electrolysis of fused salts of lead.* Electrode holders are sometimes water-cooled, to prevent them from becoming unduly heated, and occasionally even the electrodes themselves are water-cooled, as the metal tube electrode in Siemens' arc furnace, (Fig. 3, p. 5), or the water-cooled iron electrode in Borchers' aluminium furnace,† or in Gin's steel furnace, (Fig. 28, p. 104).

Production of Heat in Electric Furnaces.

As already mentioned, the rate at which heat is produced in an electric furnace may be measured by the number of watts of electrical power supplied to the furnace, allowance being made when necessary for any electrolysis that takes place. A certain rate of heating is necessary for the attainment of a definite temperature; this rate depending on the thickness and heat retaining qualities of the furnace walls, upon the size of the furnace, and upon any cooling influence, such as the introduction of fresh ore to the furnace. A few examples will now be given of the rate of heat production in typical electric furnaces, the rate being given in watts per cubic inch, or in kilowatts per cubic foot.‡

In Moissan's small furnace, (Fig. 6, p. 8), which was composed of blocks of quicklime, he employed 35 to 40 amperes at 55 volts, direct current; or 1,925 to 2,200 watts.§ The interior cavity of the furnace was about 1.75 inches in diameter, and about 1.7 inches in height, corresponding to a volume of 4.1 cubic inches. The watts per cubic inch will, therefore, be 470 to 538, or say 500

*Borchers' *Electric Smelting and Refining*, (1897 Ed.). Figs. 157, 158, and 165.

†Borchers' *Electric Smelting and Refining*, (1897 Ed.). Fig. 86.

‡1 Watt per cubic inch = 1.728 Kilowatts per cubic foot.

§H. Moissan, *The Electric Furnace*, p. 5.

as a round figure. Some allowance should be made for the heat produced in the electrodes themselves, and this would leave perhaps 400 or 450 watts per cubic inch for the interior of the furnace. This figure, as will be seen directly, is about one hundred times as great as the usual rate of heating in a fair-sized electric furnace, as used for steel making, for instance.

Moissan's electric tube furnace, contained a carbon tube in which the material to be heated was placed, and the furnace itself was composed of limestone, and was lined with alternate layers of carbon and magnesia. In this furnace he employed 300 amperes at 70 volts (= 21,000 watts), or 1,000 amperes at 60 volts, (= 60,000 watts).* The dimensions of the interior of the furnace, assuming that his perspective drawings are to scale, would be 4.4 inches long, 3.2 inches wide, and 4 inches high; corresponding to a volume of 56 cubic inches. The watts per cubic inch would vary from 380 to 1,100. A deduction for the heat produced in the electrodes themselves would reduce these figures by 10% or 20%.

An even more intense rate of heating is mentioned, in which he employs 1,200 to 2,000 amperes at 100 volts in an unlined limestone furnace.† The internal diameter is stated to be 4 inches, and assuming the height to be the same, the volume of the cavity would be 50 cubic inches. The watts supplied would be 120,000 to 200,000, or 2,400 to 4,000 watts per cubic inch. The operation of this furnace is only of short duration, the lime, produced by heating the interior of the limestone blocks, soon melting, and running like water, while vaporized lime roars out around the electrodes, and the furnace is soon destroyed. The temperature produced was limited by the rapid melting and vaporizing of the lime, but by supplying the heat at such an enormous rate, the greater part of the cavity might well be considerably hotter than the boiling temperature of melted lime.

The small furnace, first mentioned, could be used for longer periods, as the rate of heat production was so much less, and the furnace was therefore less rapidly destroyed; while the tube furnace, lined with carbon and magnesia, could be run continuously.

The Stassano steel furnace, (Fig. 37, p. 130), resembles the Moissan furnace, as the ore to be smelted is heated by radiation from an arc. The furnace described by Dr. Goldschmidt in 1903,‡ which is somewhat larger than the one figured in Dr.

*H. Moissan, *The Electric Furnace*, p. 17.

†H. Moissan, *The Electric Furnace*, p. 14.

‡*Electrochemical Industry*, vol. i., p. 247.

Haanel's Report,* took an alternating current of 2,000 amperes at 170 volts, and used about 450 horse-power. The horse-power corresponds to 336 kilo-watts, but part of this would be wasted outside the furnace. The volt-amperes are 340,000, and assuming a power-factor of 0.75 this would give 255 kilowatts consumed in the furnace. The interior of the furnace was about 40 inches cube, or 64,000 cubic inches, giving 4 watts per cubic inch, or 6.9 kilowatts per cubic foot. The difference between this rate of heating and that employed by Moissan, depends in part upon the lower temperature required, in part, upon the great loss of heat in the Moissan furnace, produced by the vaporizing of the materials of the furnace, and in part upon the larger size and better heat retaining construction of the Stassano furnace.

The Heroult steel furnace at La Praz, (Fig. 23, p. 87), figured by Dr. Haanel,† is about 7 feet long, 4 feet wide, and 2 feet high inside, giving a volume of 56 cubic feet. The power employed was 353 kilowatts,‡ or 6.3 kilowatts per cubic foot, which agrees well with the Stassano furnace.

The furnace recently employed at Sault Ste. Marie, for smelting Canadian iron ores, (Fig. 29, p. 108), had an interior volume of 18.4 cubic feet, and consumed about 166 kilowatts of electrical power, or 9 kilowatts per cubic foot.§ This is only a little larger than the figures for the Heroult steel furnace:—6.3 kilowatts per cubic foot, and the Stassano furnace,—6.9 kilowatts per cubic foot; but the meaning of the figure is not quite the same. The whole interior of the Stassano and Heroult steel furnaces is heated to about the melting temperature of the steel, and the rate of heat production for each cubic foot of the furnace is of the first importance in determining the temperature to which the furnace can be heated. In the Heroult ore-smelting furnace, however, the temperature is far from uniform throughout the interior, only the lower part being heated to a smelting temperature; and the volume of the upper part of the furnace, where the ore is gradually heated during its descent to the smelting zone, could be very much greater without the change having any material effect upon the temperature in the smelting zone of the furnace. In such a furnace it is consequently of little importance to consider the total volume in relation to the electrical power, a more significant figure being obtained by dividing the kilowatts by the

*European Commission Report, p. 11 and Figs. 9 and 10

†European Commission Report, p. 5 and Figs. 3 and 4.

‡European Commission Report, p. 53.

§Dr. Haanel, Report on Experiments at Sault Ste. Marie, 1907, p. 46, and plate vii. (Also in the "Canadian Engineer," vol. xiii., pp. 221 and 254).

volume in cubic feet of the fusion or smelting zone of the furnace. This zone is necessarily difficult to define, but assuming that the electrode, C, in Fig. 29, is in its normal working position, the smelting zone would occupy about 7 cubic feet, making the electrical power 24 kilowatts per cubic foot of the zone.

The rate of heating, in the smelting zone of this furnace, is very much greater than in a steel furnace, and this is explained by the constant supply of cooler material which absorbs most of the heat. The efficiency will tend to increase as the furnace is driven faster; but, with the more rapid smelting, the zone of fusion will become enlarged, thus corroding the walls of the furnace. There is consequently a limit beyond which it is not desirable to increase the rate of heating in electric furnaces.

The Keller furnace, (Fig. 30, p. 112), consists of two smelting shafts, with a common reservoir for the molten products. Taking the dimensions from Figs. 11 and 12 of Dr. Haanel's European report, the smelting zone, AB, of each shaft, omitting the connecting passage, CC¹, which acts as a reservoir for the fused iron and slag, will occupy about 19 cubic feet. The power used, in the first run of furnaces, Nos. 11 and 12, was 613 kilowatts,* or 306 kilowatts for each of the two shafts. This is equal to 16 kilowatts for each cubic foot of the fusion zone. If the whole volume of the shaft were considered, the power would correspond to 5 kilowatts per cubic foot, or to 6 kilowatts per cubic foot of the shaft up to the level, FG, at which the gases escape from the furnace.

These figures are less than were obtained from the Heroult furnace, the difference being due mainly to the larger size of the Keller furnace, in which the smelting zone was three times as large as in the Heroult furnace. The larger size of the Keller furnace occasioned a smaller loss by radiation and conduction per cubic foot, and a correspondingly smaller rate of heat production was required. In this connection it should be mentioned, that the rate of smelting, per cubic foot of smelting zone, in the Keller furnace, was less than one-third of the rate of smelting in the Heroult furnace, while the consumption of electrical energy per ton of pig-iron was twice as great in the Keller furnace as in the Heroult furnace. This seems to indicate that the supply of power in the Keller furnace was not quite sufficient, but as this furnace was working badly as a result of a shut-down, it is unsafe to draw deductions from its rate of smelting.

*Dr. Haanel's European Report, 1904, p. 40.

Better results were obtained in the second run, with the Keller furnaces Nos. 1 and 2.* These were stated to be identical with Nos. 11 and 12, with the exception of the connecting channel, which was absent in Nos. 1 and 2. Assuming the smelting zone to be of the same size, the rate of heat production would be only 6 kilowatts per cubic foot of this part of the furnace. The energy consumption per ton of pig-iron, in these furnaces, was a little less than in the Heroult furnace.

In the Kjellin steel furnace, (Fig. 24, p. 93), no electrodes are employed; the steel is contained in a ring-shaped trough, and is melted by an electric current which is induced in the steel just as it is in the secondary windings of a transformer.

The furnace shown in Dr. Haanel's report,† has a trough of 13 cubic feet capacity. The power delivered to the primary of the transformer was 150 kilowatts. Assuming the transformer losses to be 10% of this, 135 kilowatts would be supplied to the molten steel, or 10 kilowatts per cubic foot of the furnace.

This figure is larger than in the Heroult steel furnace, and the difference may be partly accounted for by the larger amount of waste space in the latter furnace. The efficiency of the Kjellin furnace is low, on account of the small cross section (6" by 18") of the trough containing the molten steel; and a somewhat small cross section appears to be necessary in this type of furnace.

The Gin steel furnace, (Fig. 28, p. 104), resembles the Kjellin furnace in consisting of a long trough or canal, of small cross section, containing the molten steel; but the electric current is introduced at the ends of the trough through water-cooled steel terminals. In order to reduce the loss of heat, the canal is folded upon itself like the filament of an incandescent lamp.

Mr. Gin calculates the dimensions for a number of furnaces, in a paper that has been printed in Dr. Haanel's report.‡ For a 700 kilowatt furnace, the volume of the steel in the trough would be 19.5 cubic feet, and assuming the trough to be half filled by the molten steel, its capacity would be 39 cubic feet, corresponding to 18 kilowatts per cubic foot of the trough. The trough would be nearly 30 feet long, $9\frac{3}{4}$ " wide, $19\frac{1}{2}$ " deep, and half full of molten steel.

In the Acheson furnaces, Figs. 8, and 38-41, the heat is produced by the passage of an electric current through a central

*Dr. Haanel's European Report, 1904, p. 44.

†Dr. Haanel's European Report, 1904, p. 2 and Fig. 1.

‡Dr. Haanel's European Report, 1904, p. 173.

core or through the charge itself. The charge does not melt, and remains nearly in the same position until the end of the operation. Very little data is available with regard to the actual working of these furnaces. The following examples may be given:—

In a patent by E. G. Acheson* for a method of making carbon articles of a high density and conductivity by heating them in an electric furnace without reaching the point of graphitization, the furnace is stated to be 30 feet long, 30 inches wide, and 10 inches deep inside. The power used was about 750 kilo-volt-amperes. Assuming the power factor to be 0.9 this would correspond to 10 or 11 kilowatts per cubic foot of the furnace.

The Acheson graphite and electrode furnaces are described by F. A. J. FitzGerald† who takes the data in part from Acheson's patents. The graphite furnace is said to be 30 feet long, 14 inches wide, and 18 inches deep, thus having a volume of $52\frac{1}{2}$ cubic feet.‡ The current at the beginning of the run is stated to be 300 amperes at 200 volts, and FitzGerald assumes that when the furnace has become heated it absorbs 750 kilowatts. The latter figure would correspond to 14 kilowatts per cubic foot. In the electrode furnace, the length between terminals is 30 feet, and the cross section of the piles of electrodes under treatment is 24 inches by 17 inches. Allowing a few inches of granular carbon around the electrodes, the volume of the furnace would be 150 cubic feet, 700 kilowatts were employed, corresponding to less than 5 kilowatts per cubic foot. If no allowance were made for the granular carbon, the rate of heating would be 8 kilowatts per cubic foot of the charge.

A drawing of the carborundum furnace§ shows it to be $16\frac{1}{2}$ feet long, 6 feet wide, and $5\frac{1}{2}$ feet high inside. The power used is 750 kilowatts, which is only $1\frac{1}{2}$ kilowatts per cubic foot. If, however, it is considered that part of the charge in the furnace serves as a heat retaining wall, and the calculation is limited to that portion of the charge which is converted into carborundum, the rate of heating is found to be 3 kilowatts per cubic foot.

*E. G. Acheson, U.S. patent 749,418, see *Electrochemical Industry*, vol. ii., p. 108.

†The Ruthenburg and Acheson Furnaces, F. A. J. FitzGerald, *Electrochemical Industry*, vol. iii., p. 416.

‡E. G. Acheson, U.S. patent 711,031, see *Electrochemical Industry*, vol. i., p. 130. The author has been informed by the Acheson Graphite Company that these dimensions are incorrect. If as seems reasonable to suppose the cross section for a 750 kilowatt furnace is somewhat larger than stated above, the rate of heating would be proportionately reduced, and would agree more nearly with the other figures for this class of furnace.

§The Carborundum Furnace, F. A. J. FitzGerald, *Electrochemical Industry*, vol. iv., p. 53.

Collecting the results obtained above for the power required per cubic foot of electric furnace, the following general figures may be given for moderate or large sized furnaces, using from 200 to 1,000 horse-power:—Steel melting furnaces, such as the Heroult and Stassano furnaces, employ 5 to 8 kilowatts; steel melting furnaces such as the Gin or Kjellin furnaces employ 10 to 20 kilowatts; ore smelting furnaces, such as those of Keller and Heroult, employ about 10 to 20 kilowatts per cubic foot of the zone of fusion; and the power used in furnaces of the Acheson type varies from about 3 kilowatts in the carborundum furnace to about 10 kilowatts in the graphite furnace. Small sized furnaces for electric smelting may employ as much as 30 to 100 kilowatts per cubic foot, and Moissan used no less than 500 to 5,000 kilowatts of electrical power per cubic foot of his furnaces.

Voltage Required for Electric Furnaces.

Having determined how many **watts** should be supplied to the furnace, the **voltage** of the supply must next be considered. The watts supplied are, for direct current, the product of the amperes and the volts, while for alternating current they are somewhat less; the product of volts and amperes being multiplied by a factor—the power factor—which varies from about 0.7 to 0.9 in different forms of furnace, in order to obtain the watts. The heat produced depends simply upon the product of volts, amperes and power factor,* so that it would appear possible to use either a high or low voltage, provided the watts were sufficient. If a moderate current at a high voltage could be employed, it would be a great convenience, but this is usually impracticable, because it is not generally feasible to construct a furnace having a sufficiently high electrical resistance.

The whole problem turns upon the electrical resistance of the resistor R , (Fig. 21). Suppose that a furnace needs 250 kilowatts to heat it, then, taking direct current for simplicity, in illustration, if the furnace resistance were 1 ohm, a 500 volt supply would drive a current of 500 amperes through the furnace and would develop the necessary 250 kilowatts. If, however, the furnace had a resistance of only 0.01 ohm, the current, in amperes, would be one hundred times the volts, and 5,000 amperes at 50 volts would be needed. The latter case is approximately that of

*Assuming that all the energy is converted into heat, and none of it spent in chemical work, such as electrolysis.

the experimental Heroult furnace used by Dr. Haanel, and shows what enormous currents will have to be supplied to electric-smelting furnaces, if constructed on any considerable scale, since the amperes increase with the size of the furnace far more rapidly than the volts. The use of such enormous currents is inconvenient and increases considerably the cost of cables, transformers, electrodes and electrode-holders.

Voltage of Arc Furnaces.—The voltage of a resistance furnace is nearly proportional to the current flowing through it. To double the current, nearly twice the voltage would be needed, but in the arc furnace (except perhaps in the Moissan furnace, which is so small that the arc fills the furnace) the voltage does not increase considerably with increase of current, and the voltage of the arc itself is often less as the current increases. This sounds impossible but it is a well established fact, and points to the instability of the arc unless a steadying resistor is placed in series with it. In a large furnace the resistance of the cables, electrodes and transformer or dynamo is usually sufficient for the purpose, but the writer has frequently extinguished the arc in an experimental furnace by turning on too much current, that is by cutting out too much of the regulating rheostat, and so applying too high a voltage to the arc. The resistance of an arc is not constant, but as the current increases the arc becomes larger in cross section and its resistance decreases in about the same proportion, or even faster than the current increases; the voltage in consequence remains constant or decreases.

A certain minimum voltage, which varies from about 25 to 35, is needed in order to start an arc at all; beyond this the voltage increases with the length of the arc, on account of the additional resistance that is introduced as the carbons are drawn farther apart. The voltage of an ordinary lighting arc may be obtained by the formula:—

$$E = m + nl.$$

E is the voltage, l is the length of the arc in inches, and m and n are constants, which for good pure carbons have the values 40.6 and 40 respectively.* The constants would be smaller for arcs between cored carbons, for arcs enclosed in a furnace, so that the heat of the arc was retained, and for alternating current arcs. The following figures, may be given as examples of direct current arcs in small furnaces; they have been selected from the work of Henri Moissan, whose furnace is shown in Fig. 6, page 8.

*Electric Lighting, by F. B. Crocker, vol. ii., p. 308.

TABLE VII.

Voltage of Moissan's Arc Furnace.

Amperes.	Volts.	Amperes.	Volts.
35-40.....	55	800.....	110
100.....	45	900.....	45
250.....	70, 75	1,000.....	50, 60, 70, 80, 110
300.....	60, 70, 85	1,200.....	70, 100, 110
400.....	80	2,000.....	60, 80, 100
450.....	60, 75	2,200.....	60, 70
600.....	60		

This table indicates that the voltage of the arc is not determined by the amount of current flowing through the furnace, but depends mainly upon the length of arc and the kind of vapour present in the furnace. The length of arc is unfortunately not given, but probably varied from about half an inch to two inches or three inches; aluminium vapour is mentioned as giving a long arc of two inches to two and a half inches, and the 2,000 and 2,200 ampere arcs at 60 volts were obtained in the presence of iron vapour. The actual volts across the arc will be somewhat less than the figures given, on account of the drop of volts along the electrodes as well as in the connections. This drop is quite considerable in the case of heavy currents, and would vary from about 5 to 20 or even 30 volts depending on the current and the size of carbon employed.

The alternating current is generally used in arc furnaces intended for industrial use and the Heroult and Stassano steel furnaces may be taken as examples.

The Stassano furnace, (Fig 37), resembles the Moissan furnace in general construction. A long arc, GH, is maintained between the ends of somewhat slender electrodes, and when the furnace becomes thoroughly hot, the arc may be drawn out until it traverses the whole width of the furnace. In one furnace* the width was 39", and an alternating current arc of 2,000 amperes at 170 volts was used. It will be seen that this voltage is very much lower than would be required by the formula given above; the high temperature of the furnace, the presence of metallic and

*Electrochemical Industry, vol. i., (1903), p 247.

other vapours, and the use of alternating instead of direct current all contribute to this effect.

The Heroult furnace, as shown in Fig. 23, resembles a Wellman tilting open-hearth furnace from which the gas and air ports have been removed, and two large carbon electrodes, C, C, enter through holes in the roof. The furnace is basic lined, but it would be possible to employ an acid lining. The arc does not play from one carbon to the other, as in the Moissan and Stassano furnaces, but there is an arc between each electrode and the slag and metal immediately beneath it. In this way the heat of the arc is directly communicated to the metal, and as two arcs are produced in series, the voltage of the furnace will be twice as great as that of a single arc. The furnace seen by the Commission at Kortfors took 4,000 amperes at 125 volts, the power supplied being about 450 kilowatts,* while the smaller furnace at La Praz took about 4,000 amperes at 108 volts. The power supplied was 350 kilowatts, but the current was not measured.† The voltage of each arc in these furnaces will be about 45 or 55, and the arc will be quite short, the carbons being kept just clear of the slag.

Voltage of Resistance Furnaces.—Resistance furnaces have usually a lower voltage than arc furnaces of the same size. The Heroult Ore-Smelting Furnace (Fig. 29) is of the resistance type, as no arc is formed; the current flowing between the movable electrode C, and the carbon lining at the bottom of the furnace, through the solid and liquid materials in the smelting zone. The electrical resistance of these materials causes the energy of the current to be converted into heat and largely determines the voltage of the furnace; the voltage being higher for a given current, if the contents of the furnace have a higher electrical resistance. In the recent experiments with this furnace, only 36 volts were required to maintain an alternating current of 5,000 amperes.‡

The Keller Ore-Smelting Furnace (Fig. 30) is equivalent to two Heroult furnaces, with a connecting passage between the crucibles of the two furnaces. This passage serves as a reservoir for the molten slag and iron, and also serves to connect electrically the molten metal at the bottom of each furnace; an alternative passage for the current, in case the reservoir were emptied at any time, is provided through the carbon plugs BE, B'E', and copper connector EE'. Electrically, the two furnaces are arranged in

*Dr. Haanel, European Report, 1904, p. 52.

†Dr. Haanel, European Report, 1904, p. 54.

‡Dr. Haanel, Report on Experiments at Sault Ste. Marie, 1907, p. 52.

series, the current being supplied through the two movable electrodes DA, D'A', and passing in series through the two smelting zones, AB, A'B'; and the voltage is in consequence twice as great as it would be in a single furnace of the Heroult type. In the experiments made by Dr. Haanel at Livet,* the double shaft furnace, Nos. 11 and 12, took a current of 11,000 amperes at 59 volts, and the double furnace, Nos. 1 and 2, took 7,250 amperes at 55.3 volts.

For a given size and shape of furnace, and distance between the electrodes and the molten iron in the bottom of the furnace, the voltage of the furnace will increase with the current that is passed through it. The voltage will increase less rapidly than the current, however, because at the higher temperatures produced by the increased current, the electrical resistance of the furnace contents will be less than it was with the smaller current, and so the ratio of voltage to current will be reduced. If the cross section of the furnace were increased, so that the current density remained constant, i.e., the number of amperes for each square foot of cross section of the furnace was the same as before, the voltage would remain constant; and if the height of the furnace and the distance between the movable electrode and the bottom of the shaft were increased proportionately, the voltage would increase in the same ratio. That is to say, in furnaces of similar shapes, but of different dimensions and for constant current densities, the voltage will be proportional to the linear dimensions, and the current will be proportional to the square of these dimensions. It follows from this, that the voltage is proportional to the square root of the current, and as the size of electric furnaces is increased, the voltage necessary to operate them will also increase; but with far less rapidity than the electrical current which must be supplied. In practice, the voltage will tend to increase less rapidly than the dimensions of the furnace; because in large furnaces the same current density would produce a rather higher temperature, and so would make the charge a better electrical conductor, or smaller current densities could be employed which would need a lower voltage.

The voltage of an ore-smelting furnace of the Keller or Heroult type, depends mostly upon the height to which the electrode is raised from the bottom of the furnace, and this can be easily changed during the smelting operation, thus affording a convenient means of regulating the electric current. If the current were supplied to such a furnace at an absolutely constant voltage,

*Dr. Haanel, European Report, 1904, p. 36.

any change in the resistance of the furnace would lead to a change in the amount of current, the voltage remaining constant; and in running a furnace under such conditions, the electrode would be lowered to increase the current, and raised to decrease it. In practice, the voltage at the furnace terminals is not absolutely constant, but decreases with an increase of current, on account of the resistance of cables, transformers, etc.; and, in consequence, the volts and amperes supplied to a furnace will usually vary in opposite directions. This refers, of course, to changes in the current produced by changes in the furnace itself; external changes such as a change in the speed of the dynamo supplying the current would reduce or increase both the volts and the amperes. The drop of voltage that accompanies an increase of current is not objectionable in electric smelting, and it serves to some extent as an automatic regulator of the current.

Regulation of Electric Smelting.

This is usually effected by electric motors which raise or lower the movable electrodes. The motors are started, stopped, and reversed, by instruments operated by the voltage of the furnace, in such a manner as to keep this constant. In the Keller furnace, Fig. 30, and the Heroult steel furnace, Fig. 23, there are two movable electrodes; each of these being independently regulated so as to keep a constant voltage between itself and the molten metal in the furnace. The automatic regulating apparatus for the Heroult furnace is described in Dr. Haanel's report.*

The change in electrical resistance due to a change in the height at which the electrode is kept in a smelting furnace, affords a means of adapting the furnace to a variety of voltages. Electrically, it is advantageous to operate the furnace at as high a voltage as it will take, and it is, therefore, important to ascertain how high the electrode can be raised without causing trouble in the furnace. The exact height that is most desirable will depend upon a number of factors, such as the shape of furnace, size of electrode, nature of the charge, and amount of current, but the distance between the electrode and the molten slag in shaft smelting furnaces should probably be less than the width of the crucible of the furnace.

In other types of resistance smelting furnaces, the current passes through the molten slag and metal, instead of through the melting ore, the current entering by means of two or more carbon

*Dr. Haanel, European Report, 1904, p. 6.

electrodes which dip into the fused slag, as in the Harmet furnace, (Fig. 31); by electrodes of fused metal lying beneath the slag, as in the Laval furnace, (Fig. 18); or by induction, without the use of electrodes, as in the Snyder furnace, (Fig. 47). In such furnaces, the slag becomes heated above its melting temperature, by the passage of the current, and melts or dissolves the ore which rests upon it. The voltage depends upon the shape and size of the furnace, but on account of the low specific resistance of molten slags it will usually be lower than in furnaces in which the current passes through the melting ore, as well as through the fused slag. The molten metal accumulating in the bottom of the furnace will also tend to lower the voltage, by carrying, on account of its greater conductivity, a large part of the current. Furnaces, in which the electrodes dip into the fused slag, are also less easily regulated, and changes in the amount of molten slag and metal affect very greatly the amount of current that flows through such furnaces.

In the Kjellin and Gin furnaces, the electrical resistance of the steel itself is relied upon for converting the energy of the current into heat. The specific resistance, or resistivity, of steel, even when molten, is so small that the metal must be contained in a trough or canal of considerable length and moderate cross section, in order to obtain any appreciable electrical resistance, and even then, the voltage is very small, and enormous currents must be supplied, in order to heat the furnaces. In the Kjellin furnace, already referred to, a current of 30,000 amperes is supposed to circulate around the ring of molten steel, the voltage required to drive such a current being only 7. In the Gin furnace, the voltage is also very small, the calculations already referred to being for an electrical supply at 15 volts, the currents ranging from 10,000 to 100,000 amperes. Furnaces of such low resistance are very unsatisfactory electrically; but the absence of carbon electrodes, and the production of the heat directly in the molten steel, render them very suitable for steel-making.

In the Acheson furnaces, the resistor consists of a special core of carbon, surrounded by the charge, or the charge itself is the resistor. In either case, the resistor remains solid during the operation, and cannot be lengthened or shortened in order to regulate the current. Moreover, as the furnace is intermittent in action, the temperature of the resistor is not constant, as in a smelting furnace, but rises continuously during the run. This rise of temperature reduces very considerably the resistance of the furnace, and hence, the relation between the volts and the amperes.

For example, supposing the furnace had a core of coke, the resistance would fall to about one-half its original value when the furnace became thoroughly hot, and if the heat were sufficient to graphitize the coke, the resistance would fall still further, the resistance of the heated graphite being only about $\frac{1}{8}$ of that of the cold coke from which it was originally produced. Such a furnace would be very difficult to operate with a constant voltage supply; because if it were proportioned so as to draw a suitable current when heated, the current that would flow through the cold furnace would be so small (only $\frac{1}{8}$ of the final current), that the furnace would heat up very slowly, and the consumption of power would change very considerably during the run. The price paid for electrical energy is usually based upon the maximum rate at which it will be used, and a furnace which only used 15 to 25 per cent. of its maximum power for a large proportion of the run, would be very inefficient financially. It is necessary, therefore, to change the voltage of the supply during the run, and for this purpose a special induction regulator has been devised, which will change the voltage from about 200 volts at the beginning of the run to 80 volts at the end of the run, maintaining the same power (about 1,000 H.P.) all the time.*

It will be noticed that the change in the voltage is less than the change in the resistance of the furnace. This follows directly from the relationship between volts, amperes, and watts, because (omitting any consideration of inductance), the voltage must vary, for constant power, as the square root of the resistance of the furnace. Thus, if P is the power in watts, E the voltage, C the current in amperes, and R the resistance in ohms:—

$$P = EC, \text{ and } C = \frac{E}{R}, \text{ therefore } P = \frac{E^2}{R}$$

or, for constant power, E must vary as the square root of R .

Resistors.†

The materials employed as resistors determine very largely the voltage of electric furnaces, and have been referred to under

*F. A. J. FitzGerald, *Miscellaneous Accessories of Resistance Furnaces*, Electrochem. Industry, vol. iii., p. 11.

†This convenient term for "a substance used because of its property of offering resistance to the passage of an electric current," was suggested by F. A. J. FitzGerald, *Electrochemical Industry*, vol. ii., p. 490, to avoid attaching two meanings to the word "resistance."

that heading; but it will be convenient to consider them particularly at this point.

Three cases present themselves: (1) Arc furnaces—in which the resistor consists of the intensely heated gases and vapours in the arc. (2) Furnaces having a special resisting core, in which the heat is developed. (3) Furnaces in which the current passes through, and directly heats, the charge itself.

The arc furnaces need not be specially considered, as any gases or vapours that are ordinarily present in electric furnaces, will serve to carry the current. More furnaces belong to class (3) than to class (2); and it will obviously be more satisfactory, when possible, to pass the current through the material of the charge, instead of providing a special resistor for this purpose. The electrical conductivity of the charge will usually determine whether it can be used as a resistor. Of the ordinary materials found in nature, only the metals and carbon are sufficiently conductive to carry large electrical currents; but, when heated to their melting temperature, most of the rock-forming minerals will carry an electric current; and when mixed in suitable proportions for a melting charge, and fused, they always form sufficiently good electrical conductors.

The conductivity of molten slags, enables continuous smelting furnaces to be operated electrically, although the ore fed into the furnace may be non-conducting. The furnace may be started in the first place by means of an arc between the electrodes; the heat of the arc melting some of the surrounding material, which ultimately fills the space between the electrodes with a molten conducting slag. Heat is then generated by the passage of the current through the slag, more ore becomes heated and melted, and after a time the whole crucible of the furnace becomes thoroughly heated and filled with molten slag and metal. Another way of starting such a furnace is by placing some coke between the electrodes. The coke, being a moderately good conductor, soon becomes heated by the passage of the current, and melts the surrounding ore charge. The electrodes are then pulled further apart and the operation goes on as described above. A third method consists in pouring into the furnace a potful of molten slag, when the current may be at once switched on, and the furnace will soon be in regular operation.

Although the ordinary rocks and ore minerals are very poor electrical conductors, when cold, the coke, which is often added to the charge as a reducing reagent, is a fair conductor, and, if

present in sufficient quantity, will render the charge somewhat conducting.

Electrical Resistivity.—In order to design a furnace that will carry a certain electrical current at a given voltage, it is necessary to know the numerical value of the electrical resistivity of the materials through which the current will pass in the furnace. The Resistivity, or Specific Resistance of a substance, is the resistance, in ohms, between two opposite faces of a unit cube of the material. A cube of one centimeter edge is usually referred to, but it is sometimes more convenient to know the resistance of an inch cube. If the resistivity, or resistance of an inch cube of a substance, were **R** ohms, the resistance, between the ends of a cylinder of this material, **L** inches long, and **C** square inches in

cross section, would be $R \frac{L}{C}$. The electrical resistance, in

ohms, of any conductor, shows the voltage that would be needed to maintain a steady current of one ampere, through the conductor. Electrical conductivity is the inverse of resistivity, and shows the number of amperes that would flow through a unit cube if an electrical pressure, or electro-motive force of one volt, were maintained between two opposite faces of the cube. The unit of electrical conductance is the **Mho**; that is, **ohm** written the wrong way round.

Furnaces having Special Resisting Cores.—The cores or resistors in such furnaces are usually composed of carbon, which, in the form of coke powder, for example, is of moderate conductivity, thus allowing large currents to flow, and at the same time having a sufficient electrical resistivity to allow fairly high voltages to be employed—even when the cores are of considerable cross section and moderate length. The resistivity of powdered carbon depends upon the fineness of grain, as well as upon the resistivity of the solid material from which the powder was produced. In order to obtain uniform heating, it is advisable to sort the powder, only using particles that are of a uniform size; under such conditions the resistivity increases with the fineness of the powder. The following resistivities for graphitized coke powder have been calculated from experiments by FitzGerald.* The resistivity of ordinary coke powder would probably be about four times as large.

*Francis A. T. FitzGerald. *Electrochemical Industry*, vol. ii., (1904), p. 490.

TABLE VIII.

Resistivity of Graphitized Coke Powder.

(Ohms for one cubic inch).

Size of Grains.	Cold.	Red hot.	Red hot & weighted.
Between 5 meshes and 6 meshes to the inch	0.36	0.24	0.15
Between 3 meshes and 4 meshes to the inch	0.29	0.19	0.11

The first powder had been passed through a sieve having 5 meshes to the linear inch, and had been passed over a sieve of 6 meshes to the inch. The second powder had been passed through a 3 mesh sieve and over a 4 mesh sieve. The resistivities are given for the cold powder, and at a red heat. The third column shows the resistivity of the red hot powder when a weight was laid upon it, thus making a better electrical contact between the adjacent grains. The powder was placed in an open trough, and was only four inches in depth; it would, therefore, be more lightly packed than in the core of a full-sized furnace. The figures in the last column would consequently more nearly represent regular furnace conditions. The figures are given for one cubic inch, as inches are still more frequently used, in this country, than centimeters; to convert to centimeter resistivities, multiply by 2.54—the number of centimeters in one inch.

For many purposes ordinary coke powder would form a better resistor than the graphitized material, on account of its higher resistivity; but it has this serious disadvantage, that if very strongly heated in the furnace the coke will become graphitized, and its resistivity will fall to about a quarter of its original value for corresponding temperatures. It will consequently be better, in high temperature furnaces, to use a core that has previously been graphitized, thus obtaining a more nearly constant material for the resistor.

Solid rods of carbon (amorphous or graphitized) are sometimes used as resistors, as in Borchers' resistance furnace, (Fig. 14, page 24), or in Acheson's siloxicon furnace, (Fig. 41, page 154). The resistivity of rods of carbon, such as are used for electric lighting and furnace electrodes, and of the graphitized electrodes, is very much less than that of the same material in the form of a powder. The following are approximate values:—

TABLE IX.

Resistivity of Solid Carbon.

(Ohms for one cubic inch).

	Cold.	Hot.
Amorphous00124—.00163	.0006—.0008
Graphitic00032—.00042	.00016—.0002

In this table, "amorphous" refers to the ordinary carbon electrode, or arc light carbon; while "graphitic" refers to the graphitized electrodes. The word "hot" refers to electric furnace temperatures, such as 2,000°C., or 3,000°C., and it will be obvious that only approximate values can be given.

The smaller values under the heading "cold" were determined by Mr. P. M. Lincoln, of the Niagara Falls Power Co., on rods of about 1.6 square inches cross section, and about 12 inches long. They are published by the Acheson Graphite Company in their pamphlet on Acheson Graphite Electrodes. The larger values are taken from a paper by Messrs. FitzGerald and Forssell and represent a large number of experiments on electrodes of 4 x 4 inches section, and from 40 inches to 93 inches in length. The values under the heading "hot" do not represent actual experiments, but depend on the assumption that at furnace temperatures the resistivity of carbon is one-half of its resistivity when cold. Mr. Francis F. J. FitzGerald has kindly furnished the author (before publication), with the results of his experiments,* from which the following table has been summarized. Unfortunately the experiments were not continued to sufficiently high temperatures to give much information about the resistivity at electric furnace temperatures, but as far as they go they indicate a more rapid decrease of resistivity with temperature in the graphite than in the amorphous carbon. The experiments were made at the works of the National Carbon Company.

The results quoted are from an amorphous carbon electrode, 4 x 4 inches section and 73 inches long, and from an Acheson graphitized electrode 4 x 4 inches section and 40 inches long.

*FitzGerald and Forssell, Trans. Amer. Electrochem. Soc., vol. xi.

TABLE X.

Resistivity of Amorphous and Graphitic Carbon.

Experiments by FitzGerald and Forssell.

Temperature.	Resistivity, ohms for 1 inch cube.	
	Amorphous.	Graphitic.
10°C.	.00163	.000416
61°C.	.00160	.000387
109°C.000356
185°C.000338
282°C.	.00158
390°C.	.00153
466°C.	.00150

Furnaces in which the Current Passes through the Charge.—

The writer has attempted to calculate the resistivity of the melting materials in the fusion zones of the Heroult and Keller ore-smelting furnaces, and also of molten slags themselves. The data available were very unsatisfactory, and the results obtained can only be taken as representing in the roughest way the resistivities of these materials. The Heroult and Keller smelting zones appear to have a resistivity of about 0.1 ohm for one cubic inch, varying perhaps from about 0.05 to 0.15 ohm.* The resistivity of molten slag is less than this, being in the order of 0.01 to 0.05 ohm for one cubic inch.† In the Gin and Kjellin steel furnaces, the resistivity of molten iron is an important factor; and this is very small, being about 0.00007 ohm for one cubic inch.‡

With very few exceptions, the electrodes, which serve to lead the electric current into the furnace, are composed of carbon.

*Calculated from the published drawings and electrical measurements for these furnaces, assuming that the resistivity is uniform throughout the volume between the bottom of the electrode and the surface of the melted charge.

†The resistivity of fused salts is of about this order, see J. W. Richards, Conduction in fused and solid electrolytes. Trans. Amer. Electrochem. Soc., vol. vii, p. 71.

‡G. Gin (Haanel's European Report, 1904, p. 172), gives the resistivity of molten pig-iron as 216×10^{-6} per centimeter cube ($=.000,485$ ohm per inch cube). He has also measured the resistivity of molten pig-iron at 1,300°C. (Trans. Electrochem. Soc., vol. viii, p. 289), and finds it to be 16×10^{-6} ($=.000,063$ ohm per inch cube).

Electrodes.

They are made from retort carbon, petroleum coke and coal tar; the pulverized carbon being mixed with tar and pressed through a die of the required shape and size. The electrodes are then subjected to a baking process, which drives off the volatile part of the tar, and leaves a hard, compact mass of carbon. Graphitized electrodes are made in like manner from petroleum, coke, and tar, with the addition of $1\frac{1}{2}\%$ or 2% of hæmatite; being heated in an Acheson furnace to a very high temperature. The iron which is contained in the hæmatite, effects the conversion of the carbon into graphite, and is finally expelled, by volatilization, at the extremely high temperature of the furnace; leaving the electrodes composed of compact graphite. Molten iron has the property of dissolving carbon, which separates from the iron as graphite on cooling; but it is difficult to understand how so small a proportion of iron can change the whole electrode into graphite.

Graphitized electrodes have the advantage of purity, good conductivity, and great resistance to oxidation.

Their purity renders them very advantageous in operations like the production of aluminium, in which the electrode ash enters the electrolyte, and contaminates the resulting metal. The characteristic resistance of these electrodes to oxidation, reduces their consumption, and their good conductivity has a similar effect, since smaller electrodes can be employed. Graphitized electrodes are largely used for electrolysis, but, in electric smelting furnaces, cheaper ones made of coke and tar have usually been employed; while in some cases the coke forming part of the furnace charge has been utilized for leading in the current; electrical contact being made through the charging hoppers. The kind of electrode to be employed will depend largely upon the oxidizing or reducing character of the furnace. In the former case the graphitized electrodes would be preferable, while in the latter, the ordinary kind would serve the purpose.

Approximate figures, for the resistivity of carbon and graphite electrodes, have already been given. By means of these, it is easy to calculate the drop of voltage that would be produced in electrodes of a certain length and cross section, by any particular current. The cross section of an electrode is usually determined by the amount of current to be carried. The current density or the number of amperes per square inch of cross section of the electrode, differs considerably in different types of furnaces and for different kinds of electrodes, being much higher in

graphitized electrodes than in the ordinary variety. The large electrodes used in the Heroult and Keller furnaces carry about 20 amperes per square inch, while small round electrodes and graphite electrodes carry more, up to about 100 amperes per square inch. Moissan used currents up to 200 or even 700 amperes per square inch, in small, ungraphitized electrodes, but this would be far too high for commercial work, as the carbons would become red hot and would rapidly waste away, and the consumption of electrical energy, in the electrode, would be too high to be tolerated. The loss by oxidation, of the exposed part of an electrode, can sometimes be prevented by a system of water jackets, as in the Heroult steel furnace, Fig. 23.*

The only furnaces in which some form of carbon electrode is not employed, are the electrodeless furnaces, such as the Kjellin furnace, and furnaces in which metallic electrodes, usually water cooled, are employed, such as the Gin steel furnace, the Laval ore-smelting furnace, and Borchers' aluminium furnace.

Electrode holders are employed for making electrical connection between the electrode and the cable which supplies the electric current. They are also used for supporting and manipulating movable electrodes. The holders are made of copper or bronze, which are preferable on account of their good electrical conductivity, or of iron or steel, which are cheaper and do not melt so easily if over-heated. It is not easy to maintain a thoroughly good electrical contact between the holder and the carbon electrode, because the electrodes and their holders become heated, and the expansion of the metal loosens its hold on the carbon. The relatively poor conductivity of carbon makes a large area of perfect contact desirable, while its small mechanical strength renders it difficult to clamp the holder sufficiently tightly without breaking the electrode. In addition to this, the heat of the furnace tends to render unworkable any bolts and nuts or similar mechanical devices.

Graphitized electrodes can be easily machined or threaded, and attached in this way to the holder; but for electric smelting furnaces, electrodes of rectangular cross section are more usually employed, and these are secured in their holders by bolting or clamping. The electrodes, in smelting furnaces, are usually

*F. M. Becket proposes to prevent the oxidation and destruction of carbon or graphite electrodes, by surrounding them with water-cooled jackets at the point where they enter the furnace. U.S. patent 855,441, see *Electrochemical Industry*, vol. 5., p. 279.

vertical, in order to be more easily manipulated, and are suspended by a chain, so as to be easily raised or lowered; the electric cable being attached directly to the electrode holder. The holder used in the Heroult ore-smelting furnace, Fig. 29,* may be taken as an example. The part A is made of steel, and the descending jaws JJ fit into the sides of the electrode and are prevented from spreading by the two bolts. The electrode is driven downward by wedges, thus making good contact with the jaws. The upper part B is made of sheet copper, and enables the electric cable, and the pulley and chain by which the electrode is suspended, to be placed so far above the furnace, that they will not be over-heated, while the lower part A can be cooled by air or water introduced from above. The electrodes of the Heroult steel furnace† are supported by arms from the back of the furnace, instead of by chains; this construction being better adapted to a tilting furnace. The electrode is square in section, and is surrounded by four contact pieces, one for each side. One of these pieces is attached to the arm and the other three are tightened against the electrode by a steel strap, which encircles them, and is drawn tight by a screw contained within the arm.

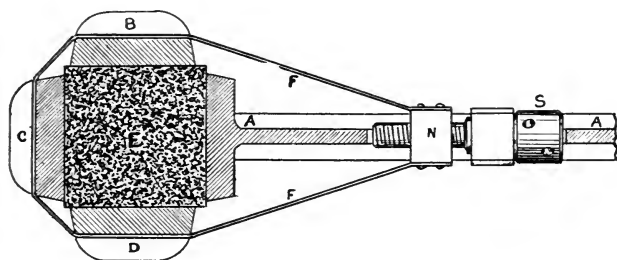

Fig. 22.—Electrode Holder of Heroult Steel Furnace.

The holder is shown in outline in Fig. 22. AA is the arm with tightening screw, S and nut N, to which is attached the strap F, which draws the contact pieces B, C and D against the electrode E, and the latter against the arm A. A cable, not shown in the sketch, is bolted to A, B, C, and D, thus distributing the current to the movable electrodes. A shield is provided to protect the holder from the heat and smoke of the furnace.

*Dr. Haanel, Report on Experiments at Sault Ste. Marie, 1907, plate vii.

†Dr. Haanel, European Report, 1904, Figs. 3-7.

Measurement of Furnace Temperatures.

In many furnace operations it is very important to be able to measure the temperature attained, and pyrometry, or the measurement of high temperatures, has developed rapidly during recent years.

For the measurement of ordinary or fuel-fired furnaces many satisfactory instruments exist,* among which may be mentioned; the Seger cones, the electrical pyrometers such as the Callendar resistance pyrometer, and the thermo-electric pyrometer, and various optical pyrometers. The Seger cones† are a series of small pyramids, consisting of clay and other materials, carefully proportioned so that each has a definite melting temperature. By placing several of these in a furnace and noting which of them are melted during the operation, it is possible to state approximately what temperature was attained. The Callendar resistance pyrometer‡ contains a coil of platinum wire carefully insulated and protected from the furnace gases, and so arranged that its electrical resistance can be accurately measured. The resistivity of pure metals increases very regularly with the temperature, and accurate temperature measurements can be made in this manner up to 1,000°C., or 1,100°C. The thermo-electric pyrometer§ consists of two wires of different metals. These are fused or twisted together at one end which is placed in the furnace, while the other ends of the wires are connected to a galvanometer or instrument for measuring a very small electric current. When the junction of the wires is heated, a small electric current is generated and in this way the temperature of the furnace can be measured. The indications of this instrument are somewhat less accurate than those of the platinum resistance pyrometer, but the thermocouple can be used up to 1,700°C., and in many ways is more convenient than the resistance pyrometer. For very high temperatures the wires are composed of platinum and an alloy of

*"High-temperature Measurements," by Le Chatelier and Boudouard, trans. by C. K. Burgess.

Pyrometers suitable for Metallurgical Work. *Journ. Iron and Steel Inst. I.*, 1904. *Methods of Pyrometry*, C. L. Waidner, *Proc. Journ. Soc. of Western Pa.*, 1904, p. 98.

†Seger Cones, Le Chatelier and Boudouard, p. 170. Hofman and Demond. *Trans. Amer. Inst. of Mining Engineers*, vol. xxiv., p. 42, and xxix., p. 682.

‡*Technical Thermometry*, a pamphlet issued by the Cambridge Scientific Instrument Co., 1906.

Callendar, *Phil. Mag.*, vol. xlvii., 1899, pp. 191 and 519.

Chappuis and Harker, *Phil. Trans. Roy. Soc. A.*, vol. 194, 1900, pp. 37-134.

§Barus, *Bull. U.S. Geol. Survey*, No. 54, Washington, 1889.

Roberts-Austen, *Trans. Amer. Inst. of Mining Engineers*, 1893.

Stansfield, *Phil. Mag.*, xlvii., 1898, p. 59.

platinum with rhodium or iridium, but for lower temperatures cheaper metals can be used as in the Bristol electric pyrometers.* Optical or radiation pyrometers depend on the measurement of the amount or the color of the light emitted by a heated substance, or of the amount of heat which is radiated.†

Far greater difficulties are met with in attempting to measure the temperatures of electric furnaces and comparatively little advance has been made in this direction. The optical pyrometers are suitable for this purpose, because, being used from outside the furnace, their use is not limited, like that of other pyrometers, by the melting of the instrument itself when used to measure a very high temperature. Some careful measurements in an electric tube furnace have been made by Messrs. Tucker and Lampen by means of a Wanner optical pyrometer.‡ Other methods of measuring electric furnace temperatures consist in placing in the furnace a piece of carbon or of some other refractory material and noting at the end of the operation what change has taken place in the material used.§ In the case of carbon the specific gravity increases with the temperature to which it has been exposed, but the change depends upon the time during which it has been heated as well as upon the highest temperature attained, and the indications of such a test are difficult to convert into degrees of temperature. In some cases the temperature of an electric furnace can be determined from the amount of electrical energy supplied to it. Thus Mr. W. C. Arsem, in working with a small vacuum electric furnace, observed how much power was needed to maintain the furnace at three lower temperatures, which could be measured, and then deduced by means of a curve the temperature that should be produced by any other amount of electric power.||

Conclusion.

A chapter on "Electric Furnace Design, Construction and Operation" would include, if the subject were fully treated, a vast

*W. H. Bristol, 45 Vesey St., New York. See *Electrochemical Industry*, vol. iv., p. 115, and F. F. Schuetz. A thermo-electric pyrometer for general industrial applications, *Trans. Amer. Electrochem. Soc.*, vol. x., p. 81.

†Optical Pyrometry, by C. W. Waidner and G. K. Burgess. Bull. No. 2, Bureau of Standards, Washington, 1905.

‡S. A. Tucker and A. Lampen, *Journ. Amer. Chem. Soc.*, vol. xxviii., pp. 846 and 853. *Trans. Amer. Electrochem. Soc.*, vol. xi., and *Electrochemical Industry*, vol. v., p. 227.

§F. A. J. FitzGerald. *Trans. Amer. Electrochem. Soc.*, vol. vi., p. 31.

||W. C. Arsem, The Electric Vacuum Furnace. *Trans. Amer. Electrochem. Soc.*, vol. ix., p. 153.

amount of very varied information. Certain branches, such as the details of electrical measurement and construction have been omitted, as being too large for inclusion, and as having been fully treated in standard works. Reference should be made to the following papers on Electric Furnace Design by Francis A. J. FitzGerald, and by C. L. Collens:—

F. A. J. FitzGerald.—Note on Some Theoretical Considerations in the Construction of Resistance Furnaces. *Tran. Amer. Electrochem. Industry*, vol. iv., p. 9. Some first principles of Electrical Resistance Furnaces, *Electrochem. Industry*, vol. ii., p. 342. *Miscellaneous Accessories of Resistance Furnaces*, vol. iii., p. 9. *Resistance Furnace for Crucibles*, p. 55. *Experiments with an Electro-Thermic Muffle Furnace*, p. 135. *The Borchers' Furnace*, p. 215. *The Ruthenburg and Acheson Furnaces*, p. 416. *The Carborundum Furnace*, vol. iv., p. 53.

C. L. Collens.—Some Principles of the Resistor Furnace Design. *Trans. Amer. Electrochem. Soc.*, vol. ix., p. 31.

CHAPTER V.

PRODUCTION OF IRON AND STEEL IN THE
ELECTRIC FURNACE.

Iron is employed in the mechanic arts in combination with variable amounts of carbon and other metalloids and metals, as wrought iron, cast iron, or steel. These terms cover a wide range of different materials.*

Cast iron, or pig iron, is the form in which the metal is usually obtained from the ore; it contains from 2% to 4½% of carbon, from ½% to 4% of silicon, and small but variable amounts of manganese, sulphur and phosphorus; the remainder being iron. The carbon and other elements are absorbed by the iron during its production in the blast-furnace, and make it more easily fusible than if it were pure; the melting temperature of pure iron being 1505°C., or 2740°F., while that of cast iron varies from about 1027°C. to 1275°C., or from 1880°F. to 2327°F., depending upon its composition. The fusibility of cast iron makes it suitable for use in the foundry, but the presence of a large amount of carbon and other metalloids renders it far less valuable mechanically than the purer forms of wrought iron and steel.

Wrought iron consists of nearly pure iron, retaining only small amounts of carbon and other metalloids, together with a small amount of admixed slag. It is made by melting pig iron in the "puddling" furnace in contact with a cinder or slag rich in oxides of iron. The carbon and other metalloids in the pig iron are largely removed by reaction with this slag, and the nearly pure forms in grains in the furnace, being too infusible to be melted. These grains of iron are welded together, but still retain some of the slag from the furnace. The puddled iron, after being rolled into bars, is cut into short pieces which are made into bundles or "piles," which are reheated and rolled into bars or other shapes. The operation of "piling" removes some of the slag, and improves the quality of the iron. A large amount of so-called wrought iron is made by piling pieces of mild steel.

Steel is a very comprehensive term, and includes:—

(a) Crucible Steel, which is made from carefully selected varieties of wrought iron or steel, has been melted in crucibles, and contains from about ¾% to 1½% of carbon, together with enough manganese and silicon to produce a sound casting.

*The different varieties of iron and steel have been defined by the International Association for Testing Materials. Journ. Iron and Steel Inst., 1907, I.

(b) Bessemer and Open-hearth Steels include all the products of these furnaces, and may range from the hardest of tool steel to a material which is practically pure iron, and only differs from wrought iron in having been fused, and being in consequence nearly free from slag, and in the presence of a little manganese, added to ensure a sound casting.

The production of iron and steel in the electric furnace may be considered under three heads:—

I. The production of steel by melting steel scrap, either alone or with the addition of pig iron, iron ore, etc., in an electric furnace.

II. The production of pig iron by heating iron ore with carbon and fluxes in an electric furnace.

III. The production of steel by heating iron ore with carbon and fluxes in an electric furnace.

The first is in commercial operation, the second is now being tried on a commercial scale, and will probably be employed to a limited extent, while the third has been experimented with by Stassano and others, but appears less promising than the other two.

I.—Production of Steel From Scrap, Pig Iron and Iron Ore.

The furnaces used are electrically heated melting furnaces, in which the scrap, pig iron, etc., can be melted, and the resulting steel can be kept molten until its composition has been adjusted. The metal is then tapped or poured and cast into moulds. A steel corresponding to any product of the crucible, Bessemer, or Siemens furnaces can be produced in this way.

The operation may be merely a melting one, in which pure steel scrap is melted and cast into ingots after small additions of pure pig iron, ferro-manganese, etc., or the charge may consist largely of pig iron, in which case considerable additions of iron ore are needed to remove excess of carbon and other constituents of the pig iron. The presence of phosphorus or sulphur in steel is objectionable, and when these are found in more than traces in the charge, they must be removed before the steel can be cast, thus prolonging the operation.

Three types of electric furnace have been employed for this kind of steel making, the Heroult furnace, Fig. 23, the Kjellin furnace, Fig. 24, and the Gin furnace, Fig. 28.

The Heroult Steel Furnace, Fig. 23,* resembles a Wellman tilting, open-hearth furnace, from which the gas and air ports have been removed, and with the addition of two vertical carbon

*European Commission Report, 1904, Fig. 4.

electrodes, CC. The furnace is heated by two electric arcs, one between each electrode and the slag or melted metal beneath it. The current passes down one electrode, through the metal and up the other electrode.

The lining of the furnace is constructed of dolomite bricks, B, and crushed dolomite, L. A is the roof, and M is the molten

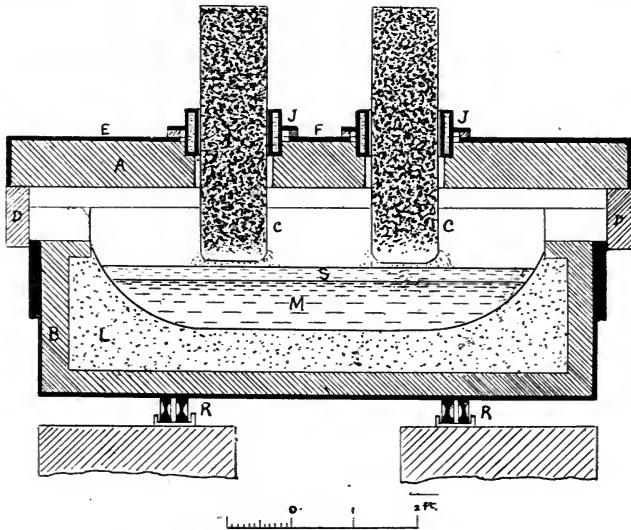

Fig. 23.—Heroult Steel Furnace.

steel, which is covered with a layer of slag S, as in the ordinary gas-fired furnace. The furnace is built in a steel case or jacket, and, unlike the open-hearth furnace, the roof, A, is also covered with steel plates, E, and is provided with eyes, not shown in the figure, by which it may be lifted off the furnace. The weakest part of the roof is around each electrode, and this part has been strengthened by water jackets, J, which enable a closer fit to be maintained round the electrode, and so reduce the loss of heat and prevent the exposed parts of the electrodes from becoming red hot, and wasting in the air. As an alternating current is used, it is not desirable to have iron or steel plates on the part of the roof between the electrodes CC, as this would increase the inductance of the electric circuit and lower the power factor of the furnace; bronze plates, F, are therefore used to cover this part of the roof. The charging doors, DD, in this furnace are placed at the ends. The electrodes are square in cross section, and are vertical when the furnace is upright, but on account of the tilting

motion of the latter, they cannot be suspended as in the ore-smelting furnaces, but are held in adjustable holders, Fig. 22, which are supported by the furnace, so that the height of each electrode in the furnace is unaffected by the tilting movement. The lower end of each is kept a short distance above the slag, leaving a space for the electric arc, and the current is regulated by raising or lowering the electrodes. This adjustment is effected by automatic machinery controlled by the voltage of the furnace; and in order that the two arcs may be kept equal, each electrode is operated separately, being controlled by the voltage between itself and the metal in the furnace. The hearth is lined with dolomite or magnesite, either of which has the advantage of being more refractory than silica brick, and of allowing strongly basic slags to be used, for the purpose of removing phosphorus and sulphur from the steel.

The Heroult furnace is very much smaller than the usual open-hearth furnace, the one at La Praz being about 7 ft. by 4 ft., internally, and taking a charge of only 3 tons, while the furnace at Kortfors was a little larger than this. For products like crucible steel the small size of the electric furnace may be no disadvantage, but if it is desired to turn out structural or rail steel, larger furnaces will have to be employed to compete with the 50-ton open-hearth furnaces.

The Haanel Commission saw the process of making both low and high carbon steel in the furnace at La Praz,* by melting miscellaneous steel scrap, purifying it by repeated additions of iron ore and lime, and then making suitable additions to obtain the required percentage of carbon, manganese and silicon. The scrap contained 0.055% of sulphur and 0.22% of phosphorus, while the final steel contained only 0.02% of sulphur and 0.009% of phosphorus, the carbon being 0.08% and 1.0% in the two steels. The scrap was melted with some ore and lime, and when fusion was complete the slag was poured off and a second slag was made by adding lime with a little sand and fluor spar as fluxes. The second slag was poured off and a third slag made in the same way before the final additions were made to the steel. The steel is more completely purified in this way, by the repeated addition of fresh slag-forming materials, than if the whole amount were added at once. In making the low carbon steel some ferromanganese was added in the furnace and a little aluminium in the ladle, while in making the high carbon steel there was also added

*European Commission Report, pp. 70-72, charges 658 and 660.

in the furnace some "carburite," which is a mixture of iron and carbon, and some ferro-silicon.

The electrical power employed* was about 350 kilowatts in each operation; the voltage was 110, and the current, which was not measured, would probably be about 4,000 amperes. The electrical energy per ton of steel was 0.17 horse-power years.† The time required was 5 hours for a small charge of 1¼ tons of low carbon steel, and eight hours for 2⅓ tons of high carbon steel. During the first part of the operation before the steel scrap is melted, the current fluctuates violently, and is regulated by hand; but after the steel has melted around the electrodes the current becomes more steady, heating by an arc beneath each electrode, and automatic regulation can be employed. The full power was not applied until about an hour after the start. Mr. Harbord states‡ that the high carbon steel is as good as corresponding grades of crucible steel, and there appears to be no reason why, in localities where water power is cheap, this furnace should not replace the crucible furnace and open-hearth furnace for the manufacture of tool steels and other special varieties of steels in which quality rather than quantity or cheapness is aimed at.

More recent data with regard to the operation of the Heroult steel furnace are given by Professor Eichhoff, of Charlottenburg.§ He furnishes a number of figures for the output and power consumption of Heroult furnaces, from which the following may be quoted:—

TABLE XI.

Operation of 5-ton Heroult Furnace.

Generator capacity.		Length of heat.		K.W. hrs. per ton.
With cold charge	} 750-K.W.	Drawing } slag. }	once..6.05 hrs.	725
			twice..6.63 "	795
			thrice..7.22 "	868
With hot charge	} 643-K.W.	With only one slag } Drawing } slag. }	..2.08 "	219
			once..2.57 "	265
			twice..3.15 "	324

*European Commission Report, pp. 53-55, charges 658 and 660.

†Better results have been obtained more recently, see Table XI.

The long ton of 2,240 lbs. is employed in this chapter.

‡European Report, pp. 85-89, and p. 115.

§Stahl und Eisen, 1907, No. 2, pp. 50-58, and Dr. Haanel's 1907 Report, pp. 139-146.

|| Molten steel from the open-hearth furnace.

With regard to the possibility of making structural steel in the Heroult furnace, it should be remembered that the material of the charge would be largely pig iron and ore, as there would not be sufficient scrap available, and this would increase the time and electrical energy required for the operation. On the other hand the pig iron could be charged molten, and the purification of the metal need not be carried so far as was necessary for tool steel, while the larger scale of the furnace would also reduce the consumption of electrical energy per ton of product. A 50-ton furnace might be expected to require, with a cold charge, about 5,000 kilowatts, or about 50,000 amperes at 110 volts; while 40,000 amperes might be sufficient if molten pig iron were used.

The cost of making structural steel in a 50-ton Heroult furnace, if a furnace of this size could be successfully operated, would probably, with electrical energy at \$10.00 a horse-power year, be about the same as in a gas-fired open-hearth furnace using coal at \$3.00 a ton. Assuming that the general cost of operating the two furnaces was the same, there remains for the Heroult electric furnace the cost of electric energy, which, at 0.10 horse-power years per ton would be \$1.00 per ton, and the cost of electrodes, which are stated to cost 20 cents per ton; while for the open-hearth furnace there is the cost of coal, which at 700 lbs. per ton would be \$1.00 and the cost of operating the gas producers and checker chambers, which would more than balance the cost of electrodes. Until larger furnaces have been built, it is not worth while to attempt to estimate in detail the cost of operating them, but the figures given are enough to show that under favorable conditions, large electric furnaces might be expected to compete with gas-fired furnaces for the manufacture of structural steel.

A Heroult furnace for the production of 50 tons of steel a day has been installed in the plant of the Halcomb Steel Co., in Syracuse, and it is likely that this will lead to further developments in size and efficiency. The furnace is being used in conjunction with gas-fired furnaces, and is charged with molten superoxidized steel from a Wellman furnace, the operation of refining being finished in the electric furnace.

An illustrated description of such a plant appeared in the *Electrochemical Industry*, vol. v., p. 272, from which the following particulars are taken:—The steel is made from scrap, etc., in a Wellman open-hearth furnace holding 25 tons. The operation is carried further than in ordinary open-hearth practice, until the carbon and phosphorus have been almost entirely eliminated;

the removal of the sulphur and oxygen and the recarburization of the steel being effected in the Heroult furnace. 4 tons of highly oxidized metal from the open-hearth furnace are transferred to the electric furnace, which requires $1\frac{1}{2}$ hours to finish this charge of steel, and has a daily output of 60 tons. At the high temperature of the electric furnace very basic slags can be used which will remove very thoroughly any sulphur remaining in the steel, and in the neutral atmosphere of this furnace the steel can be deoxidized far more completely than is possible in open-hearth practice, the slag on the molten steel becoming quite neutral or free from iron oxide. Such steel will be more sound than the usual open-hearth product. The location of the plant is not specified, and no figures are given for the amount of power employed.

The Heroult Electric Steel Plant at Remscheid, Germany, has been in operation for a year,* and was turning out, a few months ago, 25 tons of steel per day. A new plant of four times this capacity will shortly be in operation.

The uses of the Heroult steel furnace may be stated as follows:—

(a) The production of tool steel and other high grade steels by melting pure materials just as in the crucible process. Electric furnace steel is less expensive than crucible steel, and is also sounder and more tough.

(b) The production of high grade steel from less pure materials by keeping them in a molten condition beneath oxidizing slags, which are repeatedly changed until all the impurities are removed. In this process the pig iron which forms a part of the charge will preferably be supplied from the blast furnace, in the molten state.

(c) The electric furnace may be used for finishing steel which has been practically freed from carbon and phosphorus in the Bessemer or open-hearth furnace.†

The following special features of this electric furnace may be noticed:—

(a) The high temperature of the furnace which enables very basic slags to be used.

(b) The ability to exclude the air, and to finish the charge under slags which are practically free from oxide of iron, thus obtaining a sounder product.

*Electrochemical Industry, vol. v., pp. 25, 58, and 198.

†See P. L. T. Heroult, U. S. Patent 807,026, Electrochem. Industry, vol. iv., p. 31, for converting cast iron into high-grade steel by the Bessemer converter followed by the electric furnace.

(c) The slag is considerably hotter than the metal and will therefore be fluid enough to act freely on the metal without the latter being overheated. With regard to the possible overheating of the steel in electric furnaces nothing definite appears to be known, but it is considered that if steel is overheated in the presence of basic slags it will absorb nitrogen and become less tough in consequence.* In the electric furnace, however, even nitrogen is largely excluded by the gases arising from the operation, as no air or other gas need be introduced from without.

(d) In the final or recarburizing stage in the electric furnace, the conditions are so strongly reducing and the temperature is so high that even calcium carbide is formed in the slag. There is therefore practically no waste of the ferro-manganese or other metallic additions, which are of course made in the furnace itself and not in the ladle.

(e) The cost of the electric process is decidedly less than that of the crucible process, and special varieties of steel can be made commercially in the electric furnace, in places where cheap power can be obtained. The largest furnace which has been operated up to the present holds about 5 tons, and the number of kilowatt hours per ton of steel produced in such a furnace varies from 800 or 900, when cold stock is employed and is purified by repeated treatments with fresh slags, to about 200 when it is merely required to finish a charge of steel from the open-hearth furnace.

Mr. Heroult† has proposed an electrically heated steel mixer of 300 or 400 tons capacity, to receive the steel from a number of open-hearth or Bessemer furnaces, thus ensuring a uniform product, and allowing a more perfect deoxidation of the steel and separation from the slag than by the usual process of casting. Prof. Richards has suggested the use of electrical heating as an auxiliary in an ordinary open-hearth furnace, for raising the temperature of the steel through the last 100° or 200°C. before tapping, as a little electrical heat for reaching the highest temperature would sometimes save a good deal of time and fuel.

Keller Steel Furnace.‡ This is substantially the same as the Heroult steel furnace and need not be further described.

*Journ. Iron and Steel Inst., 1905, No. II., p. 777, and 1906, No. IV., p. 923.

†P. L. T. Heroult, U. S. patent 807,027, see *Electrochem. Industry*, vol. iv., 1906, p. 30.

‡European Report, p. 77, and *Electrochemical Industry*, vol. i., 1903, p. 162.

Albert Keller, *Journ. Iron and Steel Inst.*, 1903, I., p. 178.

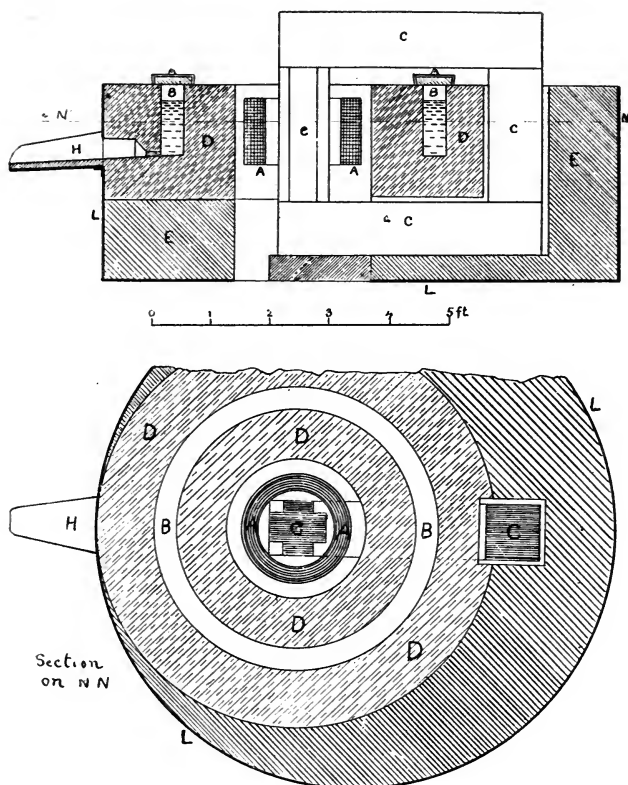

Fig. 24.—The Kjellin Steel Furnace.

The **Kjellin Furnace**, is of the induction type, and resembles a step-down transformer. In Fig. 24,* which represents a 225 horse-power furnace at Gysinge, Sweden, A is the primary winding to which an alternating current of 90 amperes at 3,000 volts is supplied. B is a circular trough containing the molten steel, and corresponding electrically to a secondary winding of one turn. C is the magnetic circuit which passes through both the primary and the secondary windings. The alternating current in the primary windings induces an alternating current in the ring of molten steel; this secondary current being estimated at 30,000 amperes and 7 volts. This furnace has the great advantage of requiring no electrodes, which is not only a gain as regards

*European Report, Figs. 1 and 2, and pp. 1-4.

trouble and expense, but avoids any contamination of the steel by the material of the electrode. The heat is generated uniformly throughout the steel, which is contained in a closed receptacle, under conditions which resemble those of the crucible steel furnace. The electrical furnace has, however, the advantage of holding as much steel as many crucibles, and of being quite free from the furnace gases which are liable to enter even a closed crucible.

Compared with the Heroult furnace, the Kjellin furnace has the objection that the annular groove containing the steel is very long in comparison with its cross section, which will cause the loss of heat to be excessive and the weight of steel to be small for a furnace of a given size. The furnace does not form a very efficient transformer, and it appears to be limited in size, the power factor becoming smaller as the furnace becomes larger, unless the frequency of the current is correspondingly reduced.* On the other hand the current can be used at high voltages, such as 3,000 or even 5,000 or 6,000 volts, which would permit of the generation of the current and its transmission over moderate distances without the use of a step-down transformer at the furnace.

The Kjellin furnace was in operation at Gysinge, Sweden, when visited by the Commission in 1904, and was usually making a high class of tool steel from pure pig iron, steel scrap and bar iron, for which purpose it seems particularly adapted. In operating the furnace the molten steel from one run is not tapped out completely, but about one-third of it is left in the groove to act as a conductor to carry the current at the beginning of the next run; the fresh charge of charcoal pig iron and pure iron or steel scrap is added to the superheated steel as fast as it can take it without chilling. No refining is attempted in this furnace, the operation being merely one of melting a metallic charge, made up in correct proportions to give a steel of the right composition.

The furnace is built in a circular iron casing, LL, which is lined with fire brick at EE. The trough B is surrounded with more refractory material, DD, for which either magnesite or dolomite bricks can be employed. The open space in the middle of the brick work, serves to cool the primary winding, by the current of air passing through it. Water jackets are also employed to protect the winding from the heat of the furnace. The groove B is covered by a series of movable lids to retain the heat as far as possible, and any of these can be removed for charging the

*In more recent furnaces this difficulty has been partly overcome.

furnace. At the end of the operation the steel is tapped from the furnace by the spout H.

In one run* the furnace contained about 1,500 lbs. of steel from the previous charge, and the fresh charge of best Swedish pig iron, steel scrap and Walloon bar iron weighed about 2,300 lbs. Small amounts of silicon-pig and ferro-manganese were added in the furnace, and 2,271 lbs. of good quality tool steel were obtained. Samples of this steel were tested chemically and mechanically by Mr. Harbord with satisfactory results. The power employed was nearly 150 kilowatts and the run lasted 6 hours. The energy consumed amounted to 0.13 horse-power years, or 850 K.W. hours per ton of steel ingots. The power factor at full load was only 0.635 with a current frequency of $13\frac{1}{2}$ cycles per second.† It will be seen that the consumption of energy for a ton of tool steel is less than in the Heroult furnace; but it must be remembered that in the latter, miscellaneous scrap was employed and washed with basic slags until free from phosphorus and sulphur, after which it had to be recarburized to obtain tool steel, while in the Kjellin furnace only the purest materials were employed, and they merely needed to be melted together in order to produce steel. On account of its smaller capacity, the Kjellin furnace will, no doubt, use more electrical energy than the Heroult for the same amount of useful work, but this difference in efficiency does not appear to be very great and may be more than offset by the absence of electrodes with their regulating appliances, heavy cables, and low voltage transformers. In other words, the Kjellin furnace may be expected to hold its own for certain classes of work, in competition with the Heroult furnace.

The Kjellin furnace has been used for high carbon steel making, but attempts were made, for the Commission, to make medium and low carbon steel in this furnace; and while the attempts were not very successful, mainly because there was not sufficient electrical power to melt the more refractory mild steel, it appeared probable that with a little more power any variety of steel could be produced in the Kjellin furnace.

During the year ending May 31st, 1906, a furnace at Gysinge, giving 1 ton of steel per tap, has produced 950 tons of steel and special steel ingots.‡

*European Report, Charge No. 546, pp. 59-61, and 47-48.

†E. C. Ibbotson, Journ. Iron and Steel Inst., 1906, No. III., p. 397. *Electrochemical Industry*, vol. iv., p. 350.

‡Further particulars of the furnaces at Gysinge are contained in a report by V. Engelhardt, *Stahl u. Eisen*, 1905, and *Electrochemical Industry*, vol. iii., (1905), p.

More recent data with regard to the furnace at Gysinge are given by the American Electric Furnace Co.* They state that the furnace requires for its operation 165 to 170 kilowatts, and has a capacity of 3,000 lbs. of metal, of which about 1,850 lbs. are tapped out at the end of each heat. The length of a heat is four hours, and the consumption of energy, when all the charge is added cold, is 800 kilowatt hours per ton. Working with hot metal from the blast furnace a larger output and greater economy is obtained. This is partly because the furnace can be completely emptied after each heat, as it can easily be restarted by pouring in a charge of molten pig iron. Thus a charge of 1,430 lbs. of molten pig iron was poured into the empty furnace, and 2,860 lbs. of cold pig and scrap were added. In six and three-quarter hours with 182 K.W. the charge was finished, the consumption of energy being 650 kilowatt hours per ton of steel ingots. The waste of material during the melting operation is found to be 2%, and the furnace lining will last for twelve weeks, costing about sixty cents per ton of steel. Purchasing electrical energy at $\frac{1}{2}$ cent per kilowatt hour, and using cold material in the furnace, the electrical energy will cost a little more than the fuel in the crucible process, but a great economy is effected by avoiding the use of crucibles. The cost for labor is also much less in the electrical method.

The Colby Steel Furnace. More than ten years before the invention of the Kjellin furnace, Mr. Edward Allen Colby had patented an induction furnace for melting metals.† In one of his first patents,‡ the primary winding is shown surrounding the circular channel, instead of being within it as in the Kjellin furnace; the furnace tilts in order to pour the charge, and is covered with a hood for the purpose of excluding the air; the hood being arranged so that the molten metal could be poured into a mould without being exposed to the air.

In his later furnaces, however, the primary winding has been placed within the secondary as in the Kjellin furnace, and the covering hood has been discarded, but the arrangement for tilting the furnace in order to pour its contents is still employed.

About two years ago Mr. Colby and Dr. Leonard Waldo§ produced the first steel made in the induction furnace in the United

*American Electric Furnace Co., 45 Wall Street, New York. Bulletin No. 1, June, 1907.

†U. S. patents 428,378, 428,379, and 428,552, of May 20th, 1890. See *Electrochemical Industry* vol. iii., p. 134.

‡U. S. patent 428,552, see *Electrochemical Industry*, vol. iii., (1905); Fig. 3, p. 299.

§*Electrochemical Industry*, vol. iii., (1905), p. 185.

States, and at the present time a Colby furnace holding 190 lbs. of crucible steel is in operation at the works of Henry Disston & Sons, near Philadelphia,* and several much larger furnaces are in process of construction.

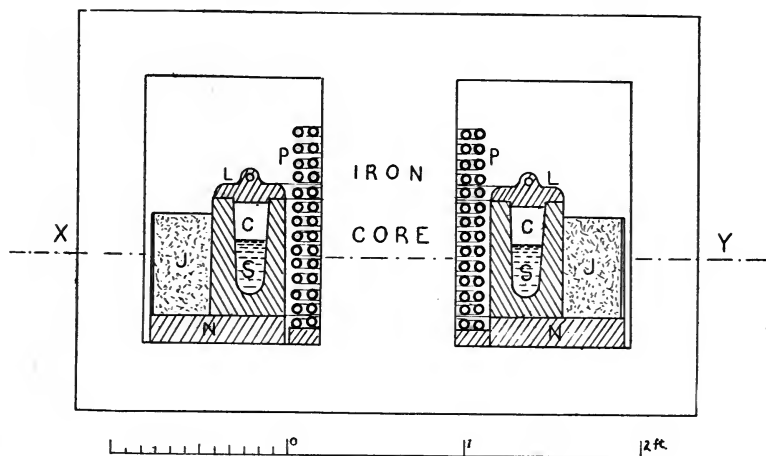

Fig. 25.—Colby Induction Furnace.

The small furnace in use at the Disston steel plant is shown in the frontispiece, and diagrammatically in Fig. 25.† It consists of a laminated iron core, around which is a primary winding of 28 turns of thick walled copper tube, P, and an annular crucible, C, containing the steel, S, which forms the secondary circuit of the transformer. The whole furnace tilts to pour the molten steel, rotating about an axis indicated by the line XY. The primary winding can be cooled very efficiently by water circulating through the copper tube, of which it is composed, and can therefore be placed in close proximity to the secondary circuit without any danger of becoming overheated. The arrangement of the coils, as shown in the figure, gives far less opportunity for magnetic leakage than in the Kjellin furnace shown in Fig. 24, and it is not surprising to find that a much higher power factor has been obtained; although this may be due in part to the small size of the Colby furnace. Mr. Colby gives the power factor as .93, and states that the average power factor after the charge of

*Trans. Amer. Electrochem. Soc., vol. xi., (1907).

Electrochemical Industry, vol. v., (1907), p. 232.

†From a sketch by Mr. Colby.

metal is fused is never below .90. The use of copper tube for the primary involves, however, the employment of relatively low voltage current, and its proximity to the crucible must cause considerable losses of heat, although this will be guarded against as far as possible by a packing of asbestos or other heat insulating substance between the crucible and the copper pipes. The crucible itself is made of graphite and clay, being similar in composition to the graphite crucibles usually employed for crucible steel making.* Such crucibles are moderately good conductors of electricity, and a portion of the secondary current will no doubt pass through the crucible itself, thus producing heat in the walls of the crucible as well as in the steel. The crucible rests upon a slab of soapstone, N, and is jacketed by some heat insulating material, J.

The following data in regard to this furnace are taken in part from the account issued to the American Electrochemical Society,† and in part from a private communication from Mr. Colby to the author:—

- Crucible capacity, 200 lbs. of steel.
- Working capacity, 100 lbs. of cast steel ingots per hour.
- Kilowatt hours per 100 lbs. of cast steel ingots, 35.
- Power factor, 0.93.
- Maximum kilowatts with 100 lbs. steel seldom exceeds 43.
- Rated size of furnace for crucible steel making, 60 K.W.
- Primary current is single phase, 240 volt, frequency 60, less than 200 amperes.
- Secondary current about 9 volts and about 5,000 amperes.
- Length of operation, 1 hour; half of which is required for fusion and the other half for refining and "killing."
- Ingots of about 90 lbs. are poured every hour, the remainder of the steel being left in the crucible for starting the next operation.
- Primary winding, 28 turns of copper tube of $\frac{3}{8}$ -inch internal, and $\frac{5}{8}$ -inch external diameter.

Induction furnaces under the patents of Colby and Kjellin are now constructed in the United States by the American Electric Furnace Company who supply furnaces from 10 K.W. upwards, and of the stationary or tilting variety. They publish‡ the following list of furnaces in operation or in course of construction:—

*For construction of the Colby crucible see U. S. patents 840,825 and 840,826, described in *Electrochem. Industry*, vol. v., p. 55.

†*Trans. Amer. Electrochem. Soc.*, vol. xi., (1907), and *Electrochemical Industry*, vol. v., (1907), p. 232.

‡*American Electric Furnace Co.*, Bulletin No. 1, June, 1907.

TABLE XII.

Induction Furnaces in Operation or in Course of Construction.

	No.	Amount	Capacity	Power
	of	of	per	for
	furnace.	charge.	24 hrs.	operation
		lbs.	lbs.	kw.
Disston Steel Works, Philadelphia, Pa.	1	150	2,100	40
Gysinge, Sweden	1	3,000	11,000	170
International Calcium Co., Gurtellen, Switzerland ..	1	7,500	22,400	320
Roehling Iron Works, Voelklingen, Germany	1	130	480	75
Roehling Iron Works, Voelklingen, Germany	1	660	2,500	110
Roehling Iron Works, Voelklingen, Germany	1	18,480	80,000	736
Roehling Iron Works, Voelklingen, Germany	1	300,000
Krupp Works, Essen, Germany	1	18,480	80,000	736
Vickers' Sons & Maxim, Eng.	1	1,500	7,500	130
Araya, Spain	1	7,500	22,400	320
Poldihutte Co., Austria	1	7,500	22,400	320
Guldsmedshyttan, Sweden ..	1	7,500	22,400	320

Note.—With regard to the apparent discrepancy between some of the figures in this table, the author is informed by the American Electric Furnace Company that some of the furnaces do not conform to their present practice, having been built before exact knowledge was available for the most efficient design, and that the varying conditions under which the furnaces are working, account for some of the seeming discrepancies. The 300,000-lb. furnace does not make steel, but is an electrically-heated mixer for holding molten pig-iron from the blast furnace. All the furnaces are of the Kjellin type with the exception of the Colby furnace at the Disston plant. In an article in the *Electrochemical Industry*, (vol. v., p. 172), the following somewhat different figures are given for some of the above-mentioned furnaces. Gysingen, Sweden: 150 kw., 955 kg., (2,100 lbs.), Voelklingen, Germany. The 736 kw. furnace has a capacity of 24 tons, pouring 15 tons at the end of each heat. The Vickers' Sons and Maxim works, Sheffield, are stated to have a 200 kg. (? kw.) furnace, and the furnace at Araya, Spain, is stated to be of 200 kw., no capacity being given. In regard to the Gysinge furnace, the 3,000 lbs. in the table is the capacity of the furnace, while the 2,100 lbs. just mentioned is the amount poured after each run. When molten pig iron is available, the whole charge of steel can be poured into ingots after each heat, but in other cases part of the steel must be left in the furnace to start the next operation.

The induction furnace is an extremely convenient and reasonably economical appliance for melting crucible steel and other metals and alloys, and there can be no doubt that when mere melting is required, as in the production of crucible steel from pure varieties of iron and steel, it is the best form of electric furnace; and that when electric power can be obtained at reasonable rates, it is both better and cheaper in operation than the crucible process.

The larger sizes of induction furnace, such as would be used in the production of structural steel, appear to have a reasonably good efficiency. A furnace of 636 K.W. is stated to have an output of 30 tons per day if charged with cold material, and 36 tons when charged with hot metal. These figures refer to the production of steel from "pig and scrap," that is by a simple melting

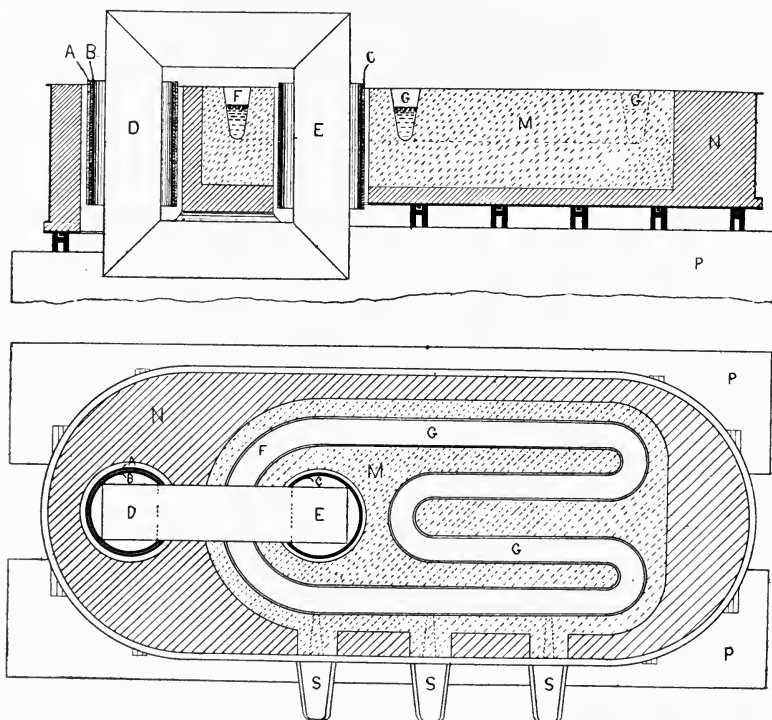

Fig. 26.—8-Ton Induction Steel Furnace.

operation, and correspond to expenditures of 590 and 490 K.W. hours respectively per ton of steel. It should be noted that these figures are apparently the results of calculations by Mr. Engelhardt,* and not the result of actual operations. About the same

*Electrochemical Industry, vol. iii., p. 295.

amount of electrical energy would probably be needed for the simple melting of pig and scrap in the Heroult furnace, but as this furnace is generally employed for purifying as well as merely melting the steel, it is not easy to make an exact comparison.

The Gronwall Furnace. A new form of induction steel furnace, invented by Messrs. A. Gronwall, A. Lindblad and O. Stalhane, is illustrated in Fig. 26, and is being erected in Sweden.* This furnace embodies certain new features which enable it to be built on a larger scale than was previously possible, without having an excessively low power factor, and without requiring current at unusually low frequencies.

The first point to notice is the trough containing the steel. Instead of being circular as in the Kjellin and Colby furnaces, this trough has a semicircular portion, F, passing around the core, E, and a folded portion, G, extending to the right of the core. This form of channel has the advantage of being more compact than a circular channel of the same length, and of having a smaller inductance. The gridiron-like construction of steel channel had been employed previously by G. Gin, Fig. 28, but its application to an induction furnace is new and appears to be a decided improvement.

Another new feature in the furnace is the position of the primary coil, which is placed, not at C, as in the earlier forms, but at A, around the outer limb, D, of the transformer core. B and C are compensator coils for reducing the magnetic leakage of the core.

In the earlier forms of induction steel furnace a serious difficulty was the very low power factor, which appeared to limit the utility of this type of furnace. Lindblad gives the following formula for the power factor of an induction furnace:—

$$\tan Y = \frac{cna}{ls} \left\{ \frac{1}{W^s} + \frac{1}{Wp} \right\}$$

where,

Y=angle of phase displacement.

n=frequency.

a=area of cross section of steel in the channel.

l=length of channel.

s=specific resistance of the steel.

c=a constant.

W^s=magnetic resistance around secondary circuit.

W^p=magnetic resistance around primary circuit.

The power factor, cos Y, is highest when tan Y is lowest, that is when the magnetic resistances are high, the frequency low,

*Dr. Haanel's 1907 Report, p. 101-104, and plates x.-xii.

and the electrical resistance of the secondary is high. The very low power factors of the earlier furnaces were caused by the excessively low electrical resistance of the secondary circuit, and the necessarily large space within the circular steel channel, which afforded an easy leakage for the lines of magnetic force. It became necessary therefore to use currents of very low frequency such as 12 or 15 for small furnaces, while even 3 or 5 alternations were proposed for larger furnaces; thus requiring special electrical machinery, and making it impossible to draw the current from ordinary power plants.

In the new furnace the steel channel turns as closely as possible around the transformer core, and yet has a considerably greater length, thus obtaining an increased electrical resistance of the secondary circuit and a greater resistance to the magnetic leakage through that circuit. The primary coil, A, is placed on the outer limb of the core, in order to have it further from the hot metal, and so to protect the insulation of the coil from the heat of the furnace. This arrangement allows of the use of higher voltage current in the primary than would be possible in the old position.

The compensator coils, B, and C, are two equal coils connected together in such a way, that if the magnetic flux in D and E were equal, no current would flow in B or C. If, however, leakage occurs, and there is a greater flux in D than in E, a current will flow in the coils in such a way as to oppose and partly prevent the leakage. An external source of electromotive force may also be used to maintain a current in the coil, C, which then becomes an auxiliary of the main primary coil, A.

The electrical deficiencies of the transformer or induction furnace may be made clearer as follows:—In an ordinary transformer the electric current flowing in the primary coil sets up a magnetic force in the core, and this force passes through both the primary and the secondary circuits. The alternating current in the primary is constantly changing in amount, and corresponding changes take place in the magnetic force in the core. The changes in the magnetic force produce an electric current around the secondary circuit. In the ordinary transformer the primary and secondary windings are close together and the magnetic force set up by the primary must pass through the secondary also, but in the induction furnace the secondary winding is a ring of molten steel and cannot be placed close to the primary winding without destroying it. The magnetic force produced by the primary has therefore a chance of escaping its work by doubling back between

the primary and the secondary coils. The arrangement shown in the figure, of one coil on each limb of the core, makes it more difficult for the magnetic force to escape without doing its work and driving an electric current around the ring of molten steel. Another deficiency of the induction furnace arises from the low electrical resistance of the secondary circuit. In an ordinary transformer the secondary winding is connected to some external resistance or other load, but in the furnace the secondary winding is shortcircuited, and having a very low resistance, its self-inductance will be high as compared with its ohmic resistance; and the current produced in the steel will consequently be far less than it would be if the secondary circuit were non-inductive, or the heat produced will be less than it would be if the ohmic resistance of the secondary formed a larger proportion of the whole resistance of that circuit. The gridiron portion of the steel channel has a smaller inductance in proportion to its length than the circular part of the channel and consequently increases the non-inductive part of the resistance and hence the effectiveness of the transformer.

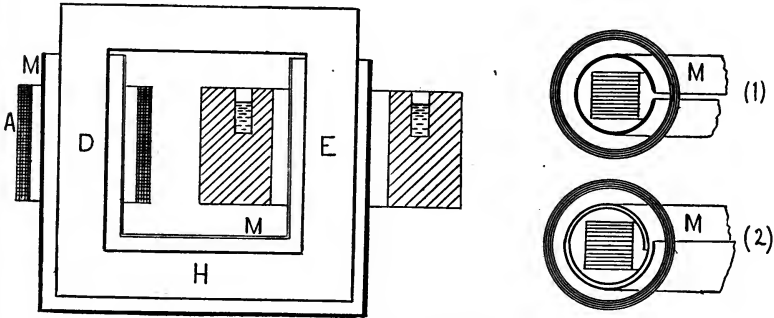
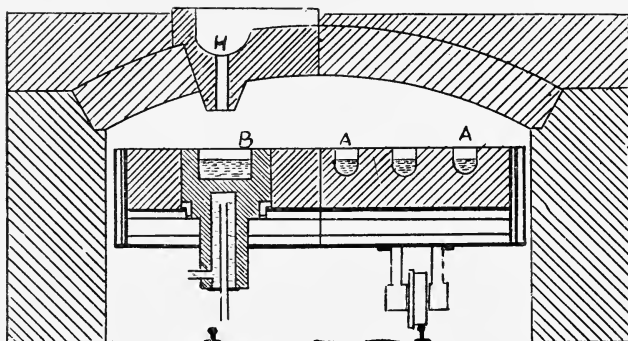

Fig. 27.—Induction Furnace with Shielded Core.

An alternative device for preventing magnetic leakage consists of a copper shield or mantle around the core, as shown at M in Fig. 27, where A is the primary coil and DEH the iron core. The lines of magnetic force cannot pass easily through this shield, as in so doing they would produce eddy currents in the metal of the shield, and these eddy currents would oppose the magnetic forces which started them. The shield must not, however, form a complete ring around the core, as it would then act as a choking coil on the primary current. It must therefore be made in the form of an incomplete cylinder, as at (1) or a spiral, as at (2).

The furnace in Fig. 26 is constructed of brickwork, N, in a metal container, and the groove containing the molten steel is



Section at X. Y.

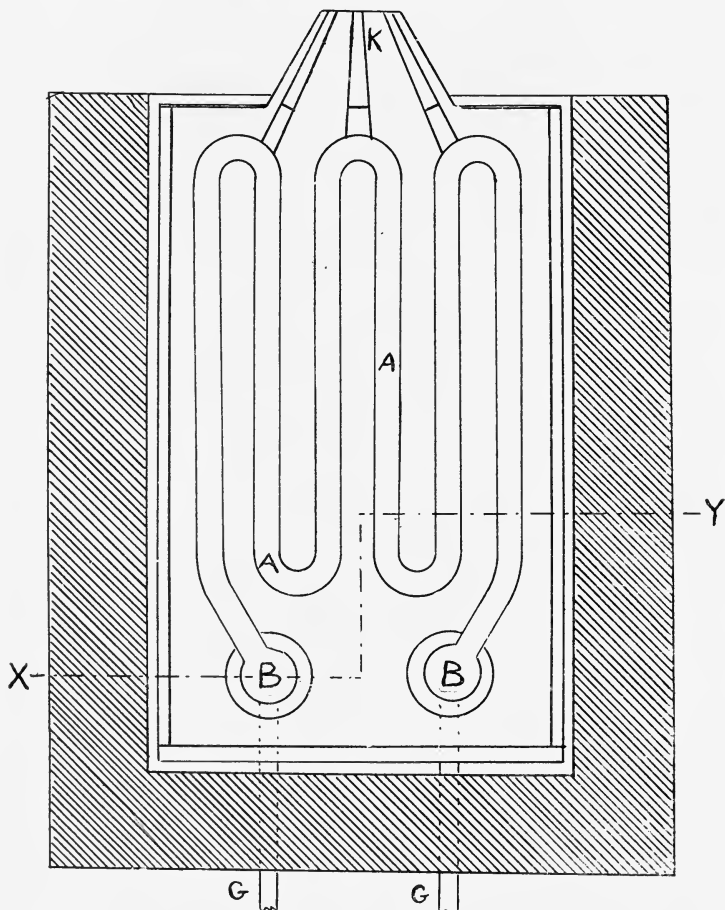

Fig. 28.—The Gin Steel Furnace.

constructed in some more refractory material, M, such as magnesite. The furnace is supported on two piers, P P, between which space is left for the transformer core D E. Three spouts, S S S, are provided at different levels; the upper spout serving to remove the slag, the middle spout to tap off the usual amount of steel, leaving a quantity in the furnace for keeping the secondary circuit unbroken, and the lower spout for emptying the furnace when necessary.

The Gin Steel Furnace.* Mr. G. Gin invented in 1897,† a furnace in which the heat is generated by the passage of a large electric current through a groove containing molten steel. In the Gin furnace the induction method is not used, but the current is led into the ends of the canal by water-cooled steel electrodes, which enter from below and form part of the furnace lining. In Fig. 28,‡ A is the groove or canal containing the molten steel, a portion of which, as in the Kjellin furnace, may be left in the furnace after each operation to start the current for the next run, and B B are the water-cooled steel terminals. On account of the low resistivity of molten steel, the trough or canal containing it should be of great length and small cross section, in order to avoid the use of excessively large currents. This was advisable in the Kjellin furnace, but it is even more necessary in the Gin furnace, because the current must be developed in a transformer and led to the furnace by cables, all of which are more expensive, for equal power, as the current is larger in amount; and the transformer and cable losses are also very large when enormous currents are employed at low voltages. In the Gin furnace the trough A is therefore made long and narrow, and in order to secure compactness, with attendant economy of heat, it is folded backwards and forwards, like the filament in an incandescent lamp, the ends, BB, being brought to the same end of the furnace.

For convenience in repairing the hearth, it is mounted on a carriage which stands in a furnace consisting of three walls and an arched roof; the fourth side being closed during the working of the furnace by a movable door. H is one of the two spouts through the roof for introducing molten pig iron. The pig iron can be converted into steel by dilution with steel scrap, as in the

*A full account by the inventor is given in an appendix to Dr. Haanel's *European Report*, pp. 165-177. Also see translation by P. McN. Bennie, *Electrochemical Industry*, vol. ii., p. 20.

†French patent, No. 263,783, Feb. 6th, 1897; see *European Report*, p. 166.

‡Modified from figures in above Report.

Kjellin furnace, or by additions of iron ore, as in the Heroult furnace. When molten pig-iron is employed there is no need to leave any steel in the furnace from the previous run. The steel is tapped from the furnace by means of the spout, K; three channels, one from each loop of the canal, leading the steel to the spout. The cables for leading in the current are connected electrically by the bars GG, to the lower part of the water-cooled terminals BB. A 700 kilowatt furnace would have a canal nearly 30 feet long, $9\frac{3}{4}$ inches wide and $19\frac{1}{2}$ inches deep,* and it would contain 8,550 lbs. of steel, which would about half fill the groove, and would require a current of about 50,000 amperes at 15 volts.

The construction and maintenance of the furnace hearth will probably be a matter of considerable difficulty; the adjacent branches of the canal being near together any leak of metal from one to the next would lead to a shortcircuiting of the current and a rapid enlargement of the leak, while the addition of iron ore in the channels will lead to a corrosion of the walls. The best material for the construction of the hearth would probably be chromite, as this is very refractory and only slightly affected by either silicious or irony slags.

The Gin process was not inspected by Dr. Haanel, as the experimental furnace was then dismantled. Mr. Gin gives a full account of his process in Dr. Haanel's Report, and a modified furnace is described in the *Electrochemical and Metallurgical Industry*, Vol. III., p. 298, but no experimental results are given, so it will be well to suspend judgment. Mr. Gin has also described an entirely new form of furnace in which vertical carbon electrodes are used.† The Gin furnace has been installed at the Plattenberg Works, Westphalia,‡ the Krupp Works, at Essen, in Germany, and the Roechling Iron Works at Volklingen.§

The Girod Steel Furnace, recently described by Dr. R. S. Hutton,|| resembles the Heroult steel furnace in general construction and operation, but only one movable electrode is employed; the return connection from the molten steel being made by means of water-cooled steel bars embedded in the hearth of the furnace. For a small furnace the single electrode may be simpler as regards construction and operation, but the water-cooled steel bars in the base of the furnace introduce an additional

*European Report, p. 173.

†Trans. Amer. Electrochem. Soc., vol. viii., p. 105.

‡Electrochemical Industry, vol. ii., p. 120, and vol. iii., p. 434.

§Dr. Haanel, 1907 Report, p. 149.

||The Girod Ferro-Alloy Works and the New Girod Steel Furnace, *Electrochem. Industry*, vol. v., p. 9. See also vol. iii., p. 434.

complication, and as only one arc is employed, instead of two arcs in series, the voltage of the furnace would probably be lower, and a larger current would be required to supply the same amount of heat. The author employed a small furnace of this type (described at the end of this chapter) for the production of steel directly from the ore, in order to avoid the use of the carbon lining which is usual in electric ore smelting furnaces. The Girod crucible furnace,* is not employed at the present time for the manufacture of steel.

Dr. Haanel gives a list in his 1907 report of twenty-two electrical furnaces in operation or in course of construction. Of these seven are Heroult furnaces, five are Kjellin or other induction furnaces, two are Gin furnaces, two Stassano, one Keller, and one Girod furnace; beside four furnaces of unspecified design (possibly Heroult) at Alleverd. That this list by no means represents all the steel furnaces that are now in operation or construction will be evident if reference is made to Table XII., in which no fewer than twelve steel furnaces of the induction type alone are listed. It is intended to employ Heroult steel furnaces at the new electric smelting works at Welland and Baird, to treat the pig iron produced by the ore-smelting furnaces.

II.—Production of Pig Iron from Iron Ore, Carbon and Fluxes.

The production of pig iron from iron ore in the electric furnace is a proposition of greater commercial importance than the manufacture of tool steel, or even structural steel; but the process is in a less advanced condition. The electrical smelting of iron ores is simple in principle; the ore being mixed with suitable fluxes, as in the blast furnace, and with sufficient carbon to reduce the iron and other materials, and to supply carbon to the pig iron. The electric current is made to pass through the mixed charge, which becomes heated; the iron being reduced and carburized, and the earthy portions of the ore melted into a slag. Less carbon is needed than in the blast furnace, where the combustion of carbon supplies the heat. This saving in carbon will offset a part, and in some cases the whole, of the cost of the electrical energy.

Several furnaces have been constructed for the electric smelting of iron ores, the most important of these being the Heroult and the Keller ore smelting furnaces, and modifications of these.

*See *Electrochemical Industry*, vol. ii., p. 309, and vol. iii., p. 434.

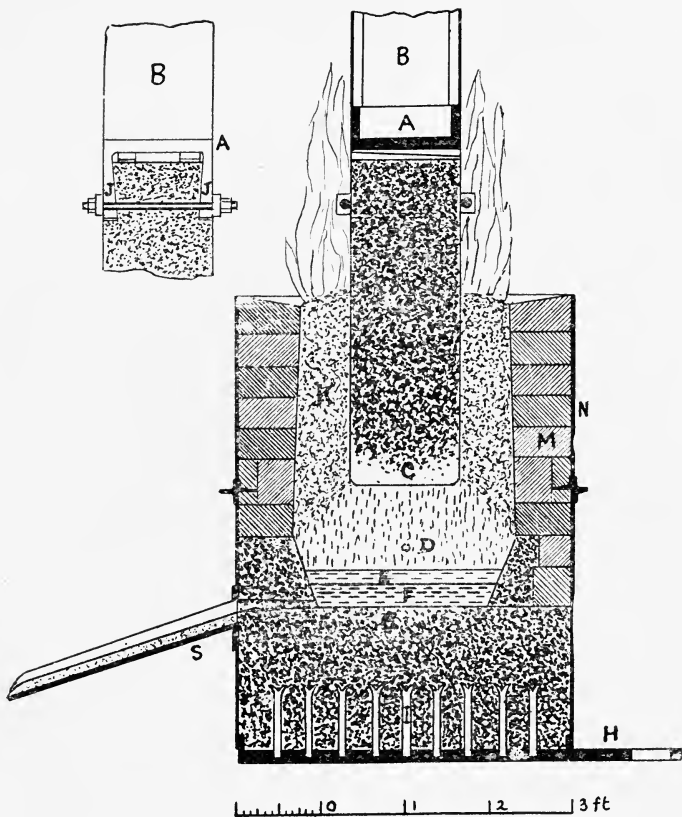

Fig. 29.—Heroult Ore-smelting Furnace.

The Heroult Furnace. The experimental Heroult furnace,* (Fig. 29), as used at Sault Ste. Marie in the spring of 1906, consisted of a nearly cylindrical shaft in which a carbon electrode, C, was suspended. The furnace was built inside an iron casing, N, 4 feet in diameter, bolted to a cast iron bottom plate, H. The lower part of the furnace was lined with carbon, put in as a paste, and this carbon lining formed the lower electrode of the furnace, the current passing between C and G through the melting charge. One cable from the transformer was connected to H, and a number of iron rods, I, served to make better contact between the

*Dr. Haanel, Report on Experiments at Sault Ste. Marie, 1907, pp. 3 and 46, and plate vii., Paul L. T. Heroult, U. S. patent 858,718; see *Electrochem. Industry*, vol. v., p. 325.

bottom plate and the carbon lining. The upper part of the furnace was lined with common fire bricks, but the carbon lining was continued to a point a little above the slag level, as it resists the solvent action of the slag much better than firebrick. The interior of the furnace tapered a little, upwards and downwards from the point at which the brick and carbon linings met. Two tapping holes were provided, the lower one which leads to the spout, S, for the pig iron, and the upper one, D, for the slag. The upper electrode was supported by the holder, AB, which has already been described (Chap. IV.), and which was suspended by a chain so that it could be raised or lowered; the regulation of the electrode would normally be automatic. The electric current was led to the carbon through the holder AB.

An iron casing is very convenient in the construction of any kind of furnace, but for an electric furnace using an alternating current, the complete iron ring, N, through which the current has to pass, would be very objectionable, as it would increase the inductance of the circuit; thus opposing the passage of the current, and lowering the power factor. On this account, a vertical strip of the iron case, 10 inches wide, was replaced by a copper plate.

In operating the furnace, the current is started between the electrode, C, and the bottom of the furnace (a little coke could be placed in the furnace, if necessary, to prevent too large a rush of current on making contact), and the ore, mixed with charcoal and fluxes, is fed in around the electrode. The heat generated by the electric current will heat the charge around the end of the electrode, and as the charge becomes partly reduced and melted it will carry the current more readily, and the electrode can be gradually raised until it reaches its normal position. The part of the furnace between C and G may be considered the zone of fusion, and contains molten pig iron, F, molten slag, E, and a mixture, D, of charcoal and melting slag and metal.

The ore charged into the furnace contains iron in an oxidized condition, and this oxide of iron is reduced by the charcoal, forming metallic iron and carbon monoxide. This direct reduction by charcoal probably takes place mainly in the lower and hotter part of the furnace, but the carbon monoxide, so formed, is itself a good reducing reagent and reacts with the oxides in the upper part of the furnace, partly reducing these and liberating carbon dioxide, which is again reduced, in part, to carbon monoxide by the charcoal in the charge. The reactions may be represented as follows:—



It will be seen that the gas escaping from the furnace must be rich in carbon monoxide, and is therefore more valuable than the gas from an ordinary blast furnace which is largely diluted with nitrogen from the blast. In the illustration this gas is represented as burning around the electrode, above the charge, but in regular practice it would be employed to preheat the charge. The carbon monoxide will not reduce the iron ore until the latter has become somewhat heated, and in electric smelting the heat will not penetrate so far up the descending column of ore as it does in the blast furnace, as there is a much smaller flow of gas to carry the heat. The shafts of electric smelting furnaces will therefore not need to be so high, in proportion, as the shafts of blast furnaces. In figures 29 and 30 the arrangement of the electrodes would also prevent a high furnace from being used, but this has been modified in later forms of the furnace, and the volume of the upper part of the furnace may be effectively increased if the ore charge is preheated by the combustion of the carbon monoxide.

Turning now to the results obtained in this furnace, Dr. Haanel reports* that, in the experimental runs, which were begun about the middle of January, 1906, and continued until the 5th of March, some 55 tons of pig iron were electrically smelted from hematite, magnetite, roasted pyrrhotite, and titaniferous ores. The furnace worked satisfactorily with all these ores, and pig iron, low in sulphur, was obtained from the roasted pyrrhotite, and other ores of high sulphur content. Charcoal forms a perfectly satisfactory reducing agent, and this is important, since in Ontario and Quebec charcoal can often be produced cheaply from mill refuse, wood or even peat, while coke, suitable for blast furnaces, must be imported. In this connection, it should be remembered that the coke or charcoal used in a blast furnace should be of good quality, and able to stand the weight of the heavy column of ore without crushing; while in the electric furnace the quality of the reducing reagent is less important, and broken charcoal and partly charred wood was found to serve the purpose. The electric furnace differs from the blast furnace in the absence of a blast of air, and in the possibility of attaining a higher temperature. Both of these differences are in favor of the

*Preliminary Report, 1906, p. 8.

electric furnace, and cause it to be a more powerful reducing and melting appliance than the blast furnace. The strong reduction helps to drive the sulphur into the slag, as calcium sulphide, and the high temperature that is attainable allows a very limey slag to be used for the removal of the sulphur. Strong reducing conditions, although desirable as removing the sulphur, have the effect of increasing the amount of silicon in the pig iron, and iron containing as much as 5% or 6% of silicon was obtained, with only 0.06% of sulphur when smelting the roasted pyrrhotite.* Dr. Haanel reports, however, that by increasing the limestone in the charge, the silicon in ferronickel pig has recently been lowered to 2%. With less sulphurous ores the iron could be obtained high or low in silicon as desired, as the degree of reduction in the furnace is quite under control.

The consumption of electrical energy, in horse-power years per ton of pig iron, varied from 0.268 to 0.333 in the later runs on iron ores.† If the carbon monoxide escaping from the furnace were utilized for preheating the ore and flux, these figures would be materially reduced and somewhat better results may be expected from furnaces of larger dimensions, and when the conditions for smelting have been more completely ascertained. The amount of charcoal used varied from 30% to 34% of the weight of the ore, or about 1,100 to 1,200 lbs. of very poor charcoal per ton of pig.

After the conclusion of Dr. Haanel's experiments at Sault Ste. Marie, the plant was purchased by the Lake Superior Power Company, and has been used for the production of ferro-nickel pig from roasted pyrrhotite.‡

The Keller Furnace, (Fig. 30),§ differs from the Heroult in having two vertical shafts, NN', communicating below by a passage, CC'. Each shaft contains a carbon electrode, D, and the current from these electrodes flows, normally, through the molten metal K in CC', but permanent carbon electrodes, BB', connected electrically by a copper bar, EE', serve to carry the current from one shaft to the other whenever the furnace is empty. H, is an auxiliary electrode which may be employed for heating the metal in K if it should ever become chilled.

This furnace has the advantage of providing a receptacle, K, for the molten metal and slag; the metal being tapped through the hole, K, and the slag through the hole, J. The receptacle,

*1907 Report, p. 84.

†1907 Report, runs 12 to 17 in which charcoal was used.

‡1907 Report, pp. 93-95

§Dr. Haanel's European Report, 1904.

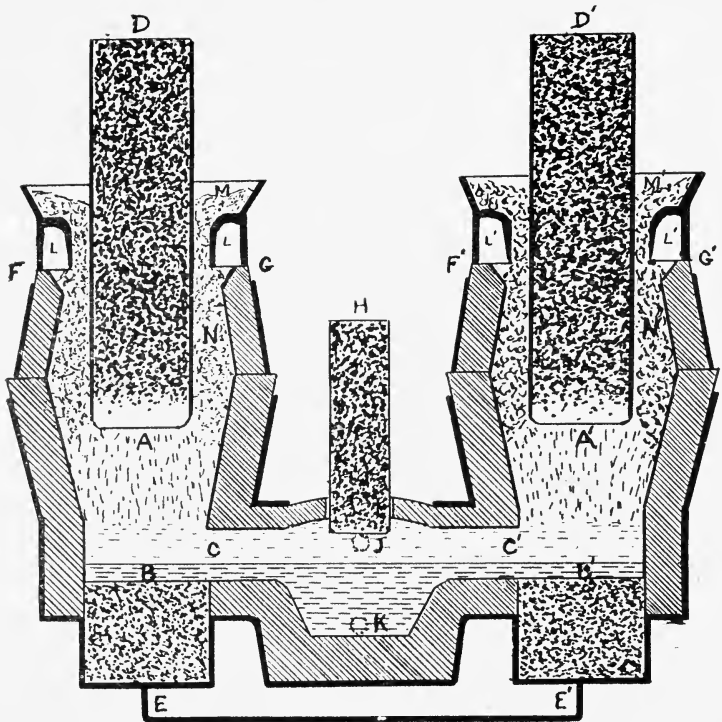

Fig. 30.—The Keller Furnace.

K, corresponding to the fore-hearth or settler of a copper furnace, receives the molten products of two, or even four shafts, thus reducing the labor of tapping; and the use of two shafts, connected electrically in series, enables the current to be employed at a higher voltage than in the case of a single shaft furnace. The working lining of the furnace is made by ramming a mixture of burnt dolomite and tar around a mould, and has been found to stand very well. As the heat is produced in the centre of the shaft, it should be possible, by suitably proportioning the furnace to keep the walls at so moderate a temperature that they might be built of ordinary fire brick, as in the blast furnace. Fire bricks are, however, rapidly corroded, even at moderate temperatures, by slags containing oxide of iron, and would only stand if the conditions were so strongly reducing as to convert the whole of this oxide to metal. It will be remembered that the working lining of the Heroult furnace was carbon, which is in-

fusible and does not corrode unless exposed to oxygen or metallic oxides, such as iron oxide. Such a lining will last if the furnace conditions are strongly reducing, and cast iron is being made, but would not last if it were attempted to produce steel in the furnace, as there would be a considerable amount of iron oxide in the slag. A basic lining, such as dolomite, would then have to be used.

The ore enters the furnace through iron hoppers, MM', which are provided with an annular space, L, into which the gases from N can easily escape instead of passing up through the ore in M. From L the gases are withdrawn in pipes and utilized in any suitable manner, such as running a gas engine or preheating the ore. The iron casing, round the furnace inspected by Dr. Haanel, was the cause of a very low power factor being obtained, and it will be omitted or modified in the future.

The Haanel Commission visited the works of Messrs. Keller, Leleux & Co., at Livet, France, in March, 1904, and during their visit some 30 tons of ore were smelted electrically.* The ore was hematite and contained 48.7% of iron and 10% of moisture. Coke, containing 7.6% of ash and 91.1% of fixed carbon, was used for reducing the ore, and the amount required varied from about 18% to 20% of the ore, from 17% to 19% of the ore and fluxes, or from 800 to 900 lbs. per ton of pig iron. The energy used, per ton of pig, was .532 E.H.P. years in the first experiment, and .253 E.H.P. years in the second experiment. In the first experiment the furnace was working badly, and the experiments at Sault Ste. Marie tend to show that the smaller of these figures may be considered reliable.

The Harmet Furnace (Fig. 31),† differs from the Heroult and Keller furnaces in having the electrodes inserted laterally into the lower part of the shaft instead of passing vertically down the furnace. The shaft, S, is enlarged below to allow of the insertion of the electrodes, EE, and the current passes between these through the melting charge, the slag, C, and the molten metal, B. The inclined lateral electrodes will probably be less satisfactory in actual use than a central electrode, because it will not be easy to regulate the current by raising or lowering them as is done in the other furnaces; supporting the electrodes in this position will also be less easy, and the walls will be apt to melt around the electrodes. On the other hand the height of the shaft, S, is

*European Report, pp. 90-109.

†Treatise on Electro Metallurgy of Iron, by Henri Harmet, European Report, 1904, pp. 124-164. Electrochemical Industry, vol. i., (1903), p. 422.

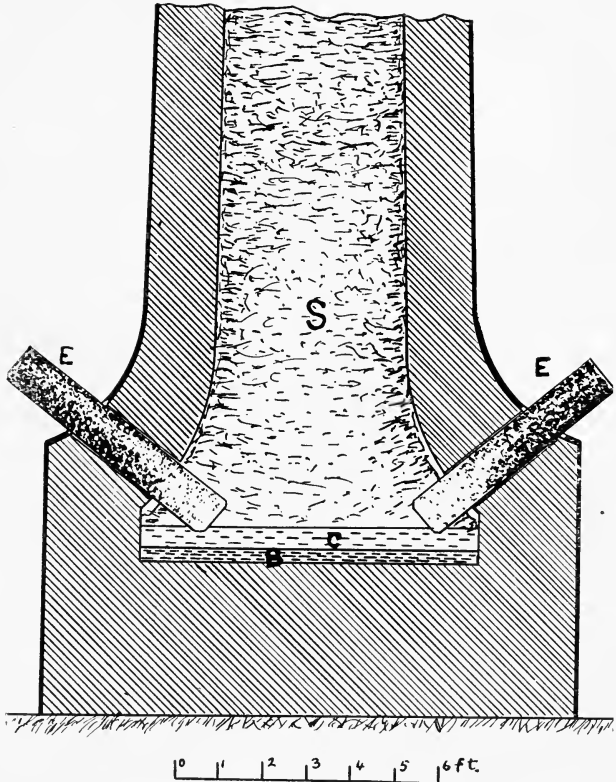

Fig. 31.—The Harmet Furnace.

not limited as in the Heroult furnace, by the length of the electrode; and better provision can be made for the preheating and reduction of the ore. Harmet utilizes the combustible gases escaping from the top of the shaft, for burning, in a separate furnace or calciner, in which the ore is calcined and preheated before charging into the main furnace. Some of the gas is returned to the foot of the shaft, being blown in at this point to supply a reducing gas for converting the iron oxide to metal, and to carry some of the heat from the crucible up the shaft, so as to preheat and reduce the descending ore. The use of the gas to preheat the ore before charging into the furnace is very desirable, but there will be no need to blow gases through the smelting shaft, because reducing gases are always formed here in large amount, and because the combustion of the gas in the calciner would heat the ore to a temperature at which it

would begin to be reduced to the metallic state directly it was introduced into the smelting shaft.

Mr. Henri Harmet has written a treatise on the electro-metallurgy of iron, which is printed in Dr. Haanel's European Report, and in this he considers every conceivable way in which iron ores can be reduced by the joint use of carbon and electrical heat, but no mention is made of any actual furnace embodying his views—even on the experimental scale.

Since the preceding pages were written, furnaces have been devised on a larger scale and with important improvements in construction and design.

The Haanel-Heroult Furnace, shown in Fig. 32,* is an improvement on Heroult's earlier furnace. The upper electrode no longer descends through the same shaft as the ore, but a separate opening is provided for it into the smelting zone of the furnace; while two lateral shafts are provided for the heating and reduction of the ore. The ore shafts, A and B, can thus be made of any desirable height, not being limited by the length of the electrode; and hoppers, K K, can be used for charging the ore, thus allowing the combustible gases to be led away through pipes, L L, for preheating the ore or other purposes. The electrode, C D, also, is protected from heat and wear except at the working end, C.

The stuffing-box, F, through which the electrode enters the furnace, is needed to prevent the escape of gases. It is made of copper, is water-cooled, and is packed with wedge-shaped rings of graphite. The graphite packing not only makes a gas-tight joint, but also ensures, an electrical contact between the electrode and the stuffing-box, so that the electric current can be led to the electrode by the arm, G. It should be noted that this use of the stuffing-box for electrode holder, not only makes it serve a double purpose, but, by leading the current into the electrode as near as possible to its working end, does away with all needless production of heat by the passage of the current through the electrode. The furnace is cased with steel plates, but the top, O, and a strip at one side, P, as well as the stuffing-box, are made of copper, so as to avoid a complete ring of iron around the path of the current.

The furnace is shown filled with ore, flux and charcoal, as it would be during operation, and with molten slag and metal at S, and M. These are drawn off through three tapping holes and spouts, of which the middle and lowest spout is for metal,

*Dr. Haanel's Sault Ste. Marie Report, 1907, plate ix., and pp. 92-93.

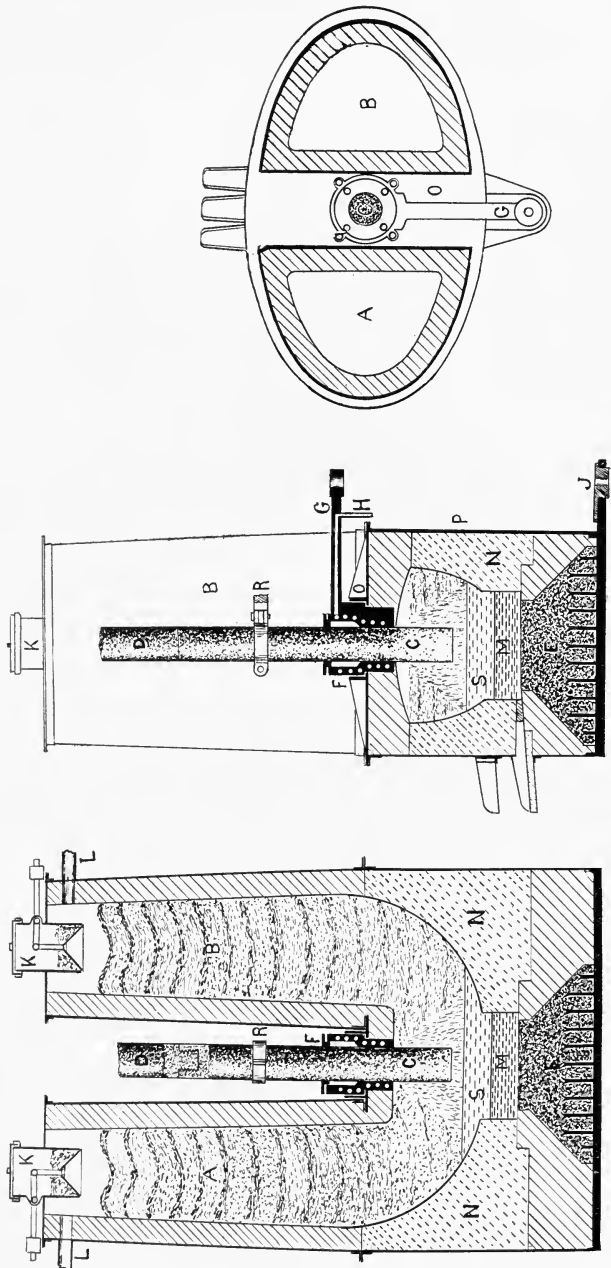

Fig. 32.—Haanel-Heroult Furnace.

while the other two are for slag. The shafts and other parts of the furnace are lined with fire-bricks, but the part, N, which is exposed to the action of melting ore, slag and metal, is composed of specially refractory material, such as magnesite. The arch across the middle of the furnace will also be particularly liable to corrosion and wear, but will be somewhat protected by the cooling effect of the stuffing-box.

The lower electrode, E, consists, as in the earlier furnace, of a rammed carbon plug, making contact with the aid of iron spikes to the heavy cast iron bottom plate and so to the contact piece, J. The upper electrode is made cylindrical, to allow of its passage through the stuffing-box. Additional lengths, D, are attached by threaded joints as shown in section in the figure, thus avoiding any interruption in operation or waste of electrode. The piece R, clamped on the electrode, serves to hold it while a new piece is being screwed on, and also for raising or lowering the electrode.

No scale is given in the original drawing, which is merely intended to show the principles on which the furnace would be constructed.

The Turnbull-Heroult Furnace, Fig. 33,* is a modification of Heroult's original furnace which has been devised by his Canadian representative, Mr. R. Turnbull. As shown in the figure there are six movable electrodes, descending into a smelting groove or canal, which forms a closed rectangle. The ore descends in a central shaft, and is distributed to the smelting groove by six inclined shoots, one descending between each adjacent pair of electrodes. The number of electrodes is preferably some multiple of three, so as to permit the use of three-phase current.

The three electrical connections, a, b, and c, on the bottom of the furnace, appear to indicate that the secondary windings of the three transformers are not connected together, but that the cables from one end of each are connected to A A, B B, and C C, respectively, while the return cables are all connected to the common terminal a b c, on the bottom plate of the furnace. The wiring for this arrangement is shown in Fig. 34, in which Xd, Yd, and Zd are the secondary windings of the transformers, each of which is connected to the furnace by two cables, one leading to a pair of movable electrodes and the other to the bottom of the furnace. It will be evident that by connecting the secondary windings in Y form as in Fig. 35, the return cables from a b c to

*Dr. Haanel's Sault Ste. Marie Report, 1907, plate xviii., and p. 147.

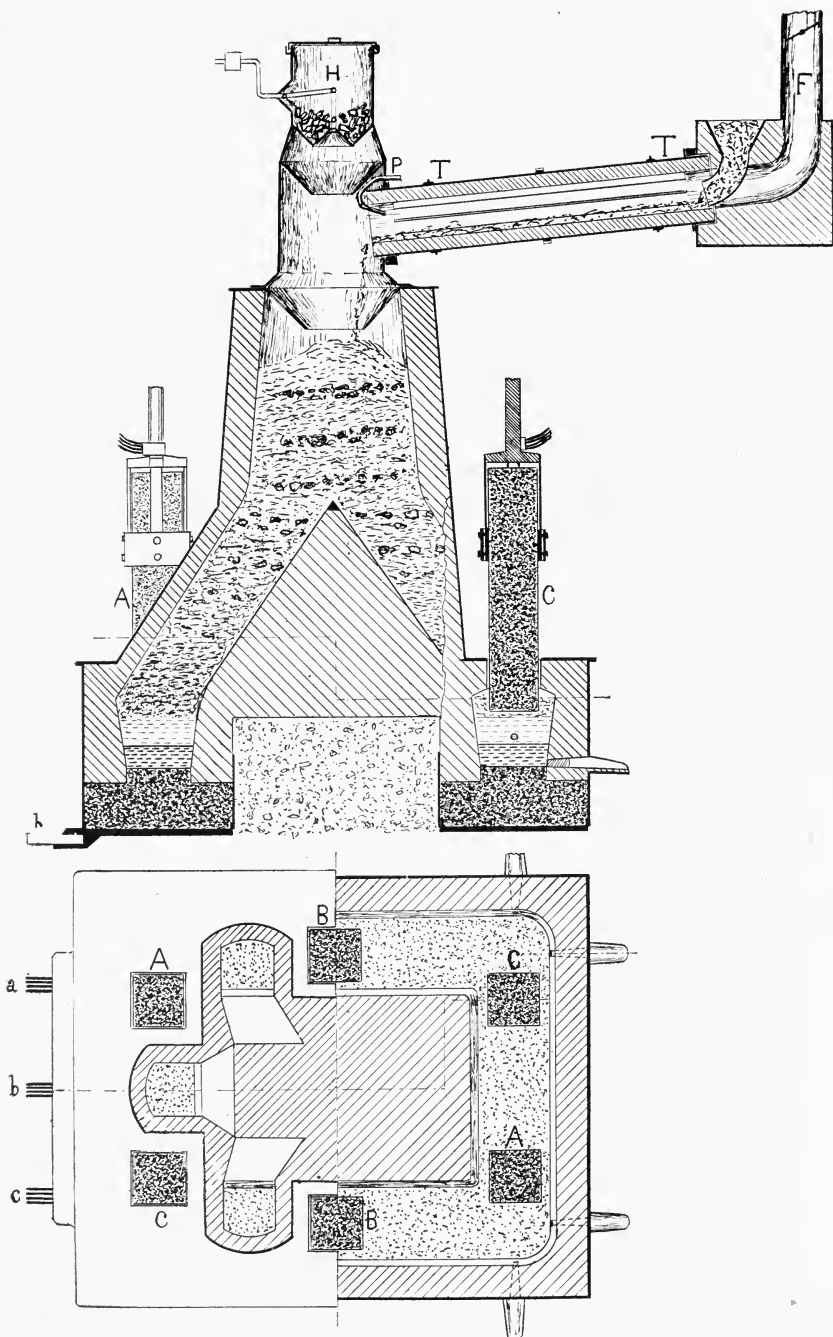

Fig. 33.—The Turnbull-Heroult Furnace.

D will be unnecessary, as each cable and pair of electrodes will serve as a return for the other cables and electrodes. Thus the current entering the furnace by the electrodes AA, will pass down to the bottom of the furnace and pass up again by the electrodes BB and CC. This arrangement will save both the cost of the return cables and the electrical energy wasted in them. It might, however, be desirable to use a single return cable between abc and D to provide for any unbalanced current, as in the

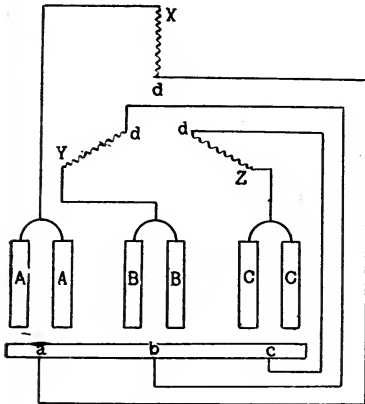

Fig. 34.

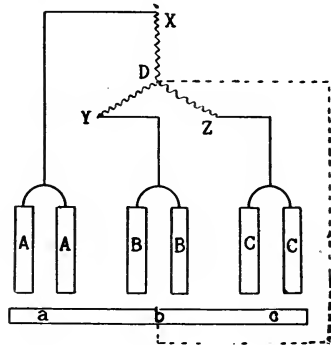

Fig. 35.

operation of replacing one of the electrodes. When the furnace is once in regular operation the current will be carried from one electrode to another through the molten iron in the smelting channel, without needing to pass into the carbon bottom of this channel, and the carbon bottom might therefore be omitted. In a furnace using three-phase current, as represented in Figs. 34 or 35, a small proportion of the current will pass from A to B, or from B to C, directly through the charge without passing through the molten metal or the bottom of the furnace. In these furnaces the voltage between A and B, or between B and C, will be 1.73 times the voltage between A and a, or between B and b; and if the moveable electrodes were near together, surrounded by a deep layer of charge, and raised considerably above the bottom of the furnace, the bulk of the current might pass directly between them, and the metal in the bottom of the furnace might become too cold or even solidify. In the Turnbull furnace, Fig. 33, there would be no danger of this as the electrodes are widely separated from each

other, and are not raised very high above the metal in the furnace.

The upper part of the furnace, Fig. 33, is designed to utilize the combustible furnace gases for preheating the ore and limestone. This cannot be done in the main shaft of the furnace, for if air were introduced there to burn the gas, it would also burn the charcoal or other fuel in the ore mixture. A lateral rotating tube, T T, is therefore provided, down which the ore gradually passes. The combustible gases from the furnace burn in this tube, air being introduced through the bent pipe P; and the products of combustion escape by the flue F. The charcoal or other fuel is introduced through the hopper H, and is thus protected from the burning gas and air.

The preheating of the ore and limestone in the tube T T, has several advantages. It calcines the limestone, removing the carbon dioxide which would otherwise rob carbon from the fuel; it roasts the ore, removing a part of any sulphur it may contain and leaving it in a better condition for the smelting operation; and the ore, by being heated, is fitted for immediate reduction to the metallic state when it enters the reducing atmosphere of the furnace, as well as gaining an amount of heat which would otherwise have to be furnished by the electric current. This preheating of the ore, is not of great importance in a blast furnace, where an ample supply of heat is carried up by the blast and serves to preheat an immense volume of ore to an increasingly high temperature as it descends in the furnace; but in the electric furnace only a small amount of heated gas rises from the smelting zone to heat the descending ore, and the preheating of the ore is therefore very desirable.

In the figure, the electrodes are shown hanging freely in the furnace, but it is intended to have some form of stuffing-box to prevent the escape of gas. Each electrode would also need to be insulated from the metal casing of the furnace. The necessary supports and gearing for the tube, T T, are omitted in the drawing. The metal and slag are drawn off through suitable spouts which are shown.

A 3,000 horse-power furnace* of this type is in course of erection at Welland, Ontario, on a piece of ground facing the Welland Canal. It is expected to produce 35 tons of pig iron per day when the ore is charged cold, or 40 tons when the preheating arrangement is used. Three 750 K.W. transformers will be employed

*Haanel Report, 1907, pp. 147-148.

to change the current from the 12,000 volts of the supply to the 30 or 40 volts required by the furnace. Regulation within these limits can be effected by taps on the secondary windings.

The furnace is intended to demonstrate the commercial possibility of the electric smelting of Canadian iron ores, even at a place where the cost of power is not very low, and where the ore has to be carried at least 150 miles. Ores from Port Arthur containing $1\frac{1}{2}\%$ of sulphur, and other refractory Canadian ores will be used in order to demonstrate the possibility of electric smelting under these conditions. A second, larger furnace, and a Heroult furnace for the manufacture of high grade steel castings, are also contemplated.

A 2,000 horse-power furnace* of similar type has been erected at Baird, California, for smelting a rich magnetite ore with charcoal. The furnace has a guaranteed output of 20 tons a day, and if successful the plant is to be enlarged to a capacity of 600-800 tons per day. The location is favorable for electric smelting on account of the abundant water power and the high price of pig iron, and of fuel suitable for use in the blast-furnace. The furnace was formally started on the 4th of July before the electrical equipment was thoroughly completed. It has made iron, seven tons being drawn on the 17th July,† but for steady work more electric power is required and will soon be supplied. Information with regard to the furnace is given in the Mining and Scientific Press of July 20th, and in the Electrochemical Industry, vol. v., p. 318, from which the following particulars are taken:—The ore is a magnetite containing about 70.2% Fe., 0.012% S., 0.01% P., 2.4% SiO₂, and insoluble. Good limestone for flux is also available. The ore is expected to cost \$1.50 per ton delivered to the smelter, and the electric power will cost \$12 per horse-power-year. The best pig iron sells at \$30 or \$32 per ton in San Francisco, and it is expected that the electric pig iron can be made and delivered there at a cost of from \$15 to \$18 per ton. In this furnace there are three electrodes which are supplied with three-phase, 60-cycle current at 50 volts; the amount of current used being stated as 30,000 amperes.

Possibilities in electric smelting. Many experiments on the electric smelting of iron ores have been made at Sault Ste. Marie and elsewhere, but they have all been hampered by inadequate electrical equipment, by the small scale of the furnace, and by

*Dr. Haanel, Report, 1907, p. 148.

†Engineering and Mining Journal, August 10th, 1907, p. 278.

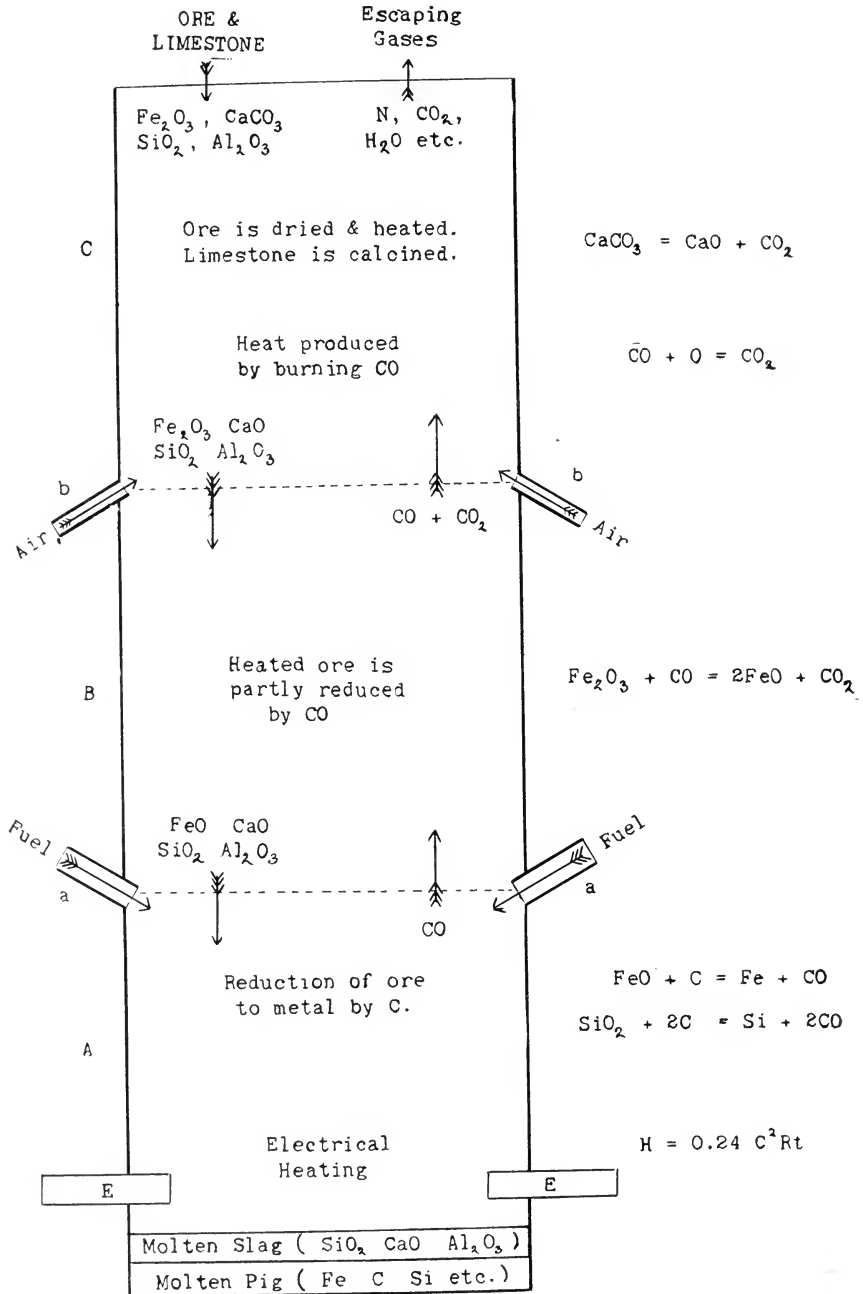

Fig. 36.—Ideal Furnace.

the fact that no use was made of the escaping furnace gases. It is very desirable to know what improvement in efficiency may be expected when all possible improvements have been made in the design and construction of the electric smelting furnace, and what is the minimum amount of fuel and electrical energy that will then be needed. For this purpose the operation of an ideal furnace may be studied, omitting for the present any consideration of how such a furnace could actually be constructed.

The ideal furnace shown in Fig. 36, consists of a smelting shaft divided by imaginary planes, aa, and bb, into three distinct zones, A, B, and C. The ore and limestone are introduced at the top of the shaft and are roasted and preheated by the gases leaving the zone, B, which are burned in C, by air introduced at bb. In the zone B, the roasted and preheated ore is partly reduced by the reducing gases leaving the zone, A, enough combustible gas being left to preheat the ore in C. In the lowest zone, C, carbonaceous fuel introduced at aa, serves to complete the reduction of the ore to the metallic state, generating at the same time reducing gases which pass up the furnace, and to carburize the resulting iron; while the necessary heat is produced by electrical energy introduced for example by the electrodes, E E. The figure merely serves to show the principles of an ideal furnace as clearly as possible, any actual furnace embodying these principles would be constructed quite differently.

It is well known that in the iron blast furnace the efficiency is limited by the composition of the escaping gases, at least half the carbon that is burnt in the furnace escaping in the half-consumed form of carbon monoxide. The same is true of any simple electric smelting furnace, such as Heroult's experimental furnace in which the charcoal was introduced with the ore at the top of the furnace. If now the carbon monoxide escaping from such a furnace is burnt and used to preheat the ore, a certain saving of electrical energy would be obtained, but there would be no saving of fuel, and the burning of the waste gases would sometimes furnish more heat than was needed for preheating the ore, thus leading to waste and overheating of the top of the furnace. In the ideal furnace of Fig. 36, part of the waste gases are used for a partial reduction of the ore in zone B, and the remainder is employed for preheating in zone C. In this way the greatest possible economy in both fuel and electrical energy can be obtained. As the fuel is used in this furnace both for reduction and for heating, it will be possible, within certain limits, to use rather more fuel and less electrical energy, or less fuel and

more electrical energy, obtaining in both cases perfect combustion and economy, and the relative price of the two commodities would decide which to employ.

A simple example will demonstrate the action of the furnace. Suppose that pure hematite ore, Fe_2O_3 is charged in at the top of the furnace and that pure carbon equal to 15% of the weight of the ore, (two atoms of carbon to each molecule of ferric oxide), is charged at aa, together with as much additional carbon as is needed to carburize the iron. The ore, preheated in C, will be reduced to FeO in B, and in A, the FeO will be reduced to metallic iron. The equations show how this works out, and that on entering C, half of the carbon will have been fully burnt, and half will be in the form of carbon monoxide.

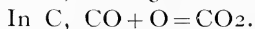
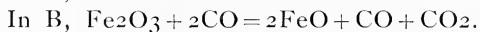
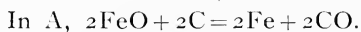

The heat value of the carbon monoxide burning in C, is 35% of the original heat value of the carbon, and this, with the heat carried up by the furnace gases would heat the ore to about $1,500^\circ\text{C.}$, which would be needlessly high. If on the other hand the carbon were reduced to about 11% of the ore (three atoms of carbon to two molecules of ferric oxide) the whole of the carbon would be required for reduction, leaving nothing for pre-heating. Deciding on some proportion of carbon between 11% and 15% of the ore, it would be possible to calculate how much electrical energy would be needed to supply the remainder of the heat for smelting.

In the experiments that have been made in electric smelting, non-volatile fuel such as coke or charcoal has been employed, because the volatile matter arising from a fuel like soft coal would not only be wasted but would have made the operation of the furnace decidedly unpleasant. In the ideal furnace, ample provision is made for the use of carbonaceous gases in the zones B and C, and any kind of fuel, even oil or natural gas, could be used effectively if introduced at the point aa.

The fuel entering the ideal furnace is completely burnt before it leaves the furnace, and the whole value of it and of the electrical energy may be communicated to the charge. The fuel is used in part for the chemical work of reducing the oxides to metal and carburizing the resulting iron, and the heat from the remainder of the fuel and from the electrical energy is used in part to furnish heat for the chemical changes that must be

effected in the ore, and in part leaves the furnace in the molten metal and slag, in the gases escaping from the top of the furnace, and by conduction through the walls of the furnace. The heat consumed in chemical reactions is an essential part of the operation, the heat carried out by the molten slag and metal is usually considered to be an unavoidable loss, though some of this might be recovered if it were worth while, the heat escaping in the gases at the furnace top may be reduced to a very small proportion of the whole, and the loss by conduction through the walls can be reduced to a moderate proportion in well built furnaces of large dimensions.

A few examples will now be given to show what will be the minimum amount of fuel and electrical energy needed for smelting an iron ore in such a furnace.

The first example is one given by Prof. Richards* and shows how much electrical energy and good charcoal would be needed to smelt a magnetite ore, obtaining a gray pig iron.

The magnetite ore contains:—

	Per Cent.		Per Cent.
Fe ₂ O ₃	60.74	MgO	5.50
FeO	17.18	P ₂ O ₅	0.04
SiO ₂	6.60	S	0.57
Al ₂ O ₃	1.48	CO ₂	2.05
CaO	2.84	H ₂ O	3.00

It is to be mixed with a good variety of charcoal, assumed 90% carbon and 10% moisture, and with enough pure silica sand to make a slag with 33% silica. The pig iron is to contain 4% carbon, 3.5% silicon, and 92.4% of iron. One ton of pig iron will require 1.654 tons of iron ore for its production. Taking first the case in which the gases entering zone C, contain two volumes of CO₂ to one volume of CO. The carbon needed for one metric ton of pig will be 224 kilograms; that is 249 kilograms, or 550 lbs. of charcoal. The electrical energy required will depend upon how much heat is lost by conduction and radiation from the furnace, and in the escaping gases. Supposing first that the gases are quite cold, and that no heat is lost by radiation, etc., the electrical energy needed would be about 0.13 horse-power-years per metric ton of pig, while if the more reasonable assumption were made that the gases escaped at 300°C., and that the losses by conduction and radiation from the

*Richards Metallurgical Calculations, vol. ii., Problem 76, p. 404.

furnace were 20% of the heat generated, (that is of the electrical heat and of the heat produced by the gases burning in the zone C), 0.20 horse-power-years of electrical energy would be needed. In this case the heat produced in C by burning gases was about 30% of the heat produced electrically. It would be possible to use rather less charcoal and more electrical energy, or less electrical energy and more charcoal than indicated in this example, but taking these figures as fairly typical of the amount of good charcoal and of electrical energy actually employed in the furnace, it will be necessary to make certain additions if the results are to represent working conditions. Thus to the electrical energy must be added the losses in transformers, cables and connections, say 10%, raising the figure to 0.22 horse-power-years, and a further addition must be made to allow for the fact that the furnace will not be operated continuously during the year, and that even when it is running it will not always draw the full power for which payment is made. In this connection it will not be necessary to consider the time when the furnace may be out of work for long periods for repairs, as provision would be made by having a spare furnace, to employ the power as regularly as possible. A certain loss of charcoal will occur through mechanical losses, and it will probably be safe to allow 600 lbs. of charcoal and 0.25 E.H.P. years per ton of pig iron as the final solution of the above problem.

As another example may be taken the 13th experimental run with the Heroult furnace at Sault Ste. Marie in February, 1906.* The run lasted 61½ hours, the mean current was 5,000 amperes at 35.7 volts, with a power factor of 0.919, giving 164 as the mean kilowatts during the run. 12,858 lbs. of pig iron were obtained with a consumption of 1,140 lbs. of charcoal and 0.268 E.H.P. years per ton of pig.

The ore was magnetite from Wilbur mine, containing:—

SiO ₂ — 6.20%	Al ₂ O ₃ —2.56%	P ₂ O ₅ —0.023%
Fe ₂ O ₃ —55.42%	CaO—2.00%	(P—0.01%)
FeO—23.04%	MgO—6.84%	S—0.05%
(Fe—56.69%)	MnO—0.26%	CO ₂ , etc.—3.61%

The charcoal contained, 14.0% moisture, 27.56% volatile matter, 55.9% fixed carbon, 2.54% ash, and 0.058% sulphur.

*Dr. Haanel, 1907 Report, p. 46. The figures in the Report refer to the 2,000 lb. ton of pig iron. In this book the author has adopted the long ton of pig iron, and occasionally the metric ton which is almost identical, as agreeing more generally with commercial practice.

During the run 21,150 lbs. of ore were smelted with 6,555 lbs. of charcoal, and 1,191 lbs. of sand for flux. The sand contained 81.71% of silica, and 14.27% of alumina, with 1.6% of lime and 1.11% of magnesia.

The mean analysis of the pig iron was:—

Si, 1.75%; S, 0.029%; P, 0.022%; Mn, 0.23%; C, 4.58%.

Supposing that the ore were smelted in a simple furnace such as was actually used, in which the ore, flux and charcoal are all charged into the furnace at the top, and no use is made of the escaping gases, it will be necessary to make some assumption in regard to the composition of these gases as no information is given. Assuming that they consisted of equal volumes of CO and CO₂, it will be found that the carbon required to reduce the ore and carburize the pig iron will be 14% of the ore, which will correspond to 25% of charcoal, or 930 lbs. of charcoal per ton of pig. In the actual case 1,140 lbs. were used, part of which was, however, burned on the top of the charge. Assuming further that the gases escape at 400°C, and that 20% of the electrical heat is wasted by radiation and conduction from the furnace, a calculation showed that 0.267 E.H.P. years per ton of iron would be needed, a figure which agrees better than could be expected with the amount actually used, which was 0.268.

If now the same charge were smelted in the ideal furnace, so that the escaping gases were utilized to preheat the charge, and allowing for the loss of 20% of the electrical heat and 20% of the heat produced by the burning gases, it will be found that only 0.216 E.H.P. years would be needed.

In this calculation only the fixed carbon in the charcoal has been considered, but with the ideal furnace the volatile matter in the charcoal would also be of use for reducing and preheating the ore in the upper zones of the furnace. A smaller amount of charcoal and electrical energy would therefore be sufficient.

In conclusion it may be stated that in an electric furnace of good construction, one ton of pig iron should be obtained with the use of 600 to 800 lbs. of charcoal and about 0.20 to 0.22 E.H.P. years, and that in order to allow for delays the amount of electrical energy should be raised to about 0.25 E.H.P. years.*

The only furnace illustrated in these pages in which the escaping gases are used to preheat the charge is the Turnbull furnace, Fig. 33. The main part of this furnace corresponds to

*These figures apply to ores of 50 per cent. or 60 per cent. of iron. For poorer ores a larger amount of electrical energy would be needed, but the amount of charcoal per ton of pig would not be much increased.

zone A of the ideal furnace and the preheating tube to zone C. There is thus nothing corresponding to zone, B, in which the gases from the lower part of the furnace can exercise their reducing action on the preheated ore. It remains to be seen whether this zone will be required in practice.

After devising the ideal furnace of Fig. 36, in which the greatest advantage is taken of the fuel and of the electrical power, the author found that it had already been invented and patented by Paul Heroult,* who introduces the air by tuyeres at bb, and supplies the fuel by a vertical tube down the centre of the furnace to the level aa.

Collecting the results that have been obtained in the electrical production of pig iron from the ore, it may be stated that the process is technically successful, and gives better results than the blast furnace in regard to the use of sulphurous ores, titaniferous and similar refractory ores and ores in a state of powder, such as iron sand or ores which have been concentrated by magnetic or similar processes. The process also allows of the use of inferior and, therefore, cheaper fuel. The power required is about $\frac{1}{4}$ of a horse-power year, depending on the richness of the ore. The fuel used for reducing and carburizing the iron is 600 or 800 lbs. of coke or charcoal, which need not be of good quality.

Comparing the cost of smelting by the two processes, apart from considerations of scale working, which will at first greatly hamper any electric smelting project, the main items of cost to compare are the fuel and the electric power. Thus in the electric furnace the ton of pig iron would require, at present, $\frac{1}{4}$ horse-power year, and 600 or 800 lbs. of coke or charcoal, while the blast furnace would require some 1,900 or 2,000 lbs. of coke for pure and easily reducible ores, and as much as 2,500 lbs. or 3,000 lbs. when poor ores and coke are used. Balancing the cost of $\frac{1}{4}$ horse-power year against the cost of the coke that is saved, will give a general idea of the prices of coke and power which would permit of electric smelting. Of the other expenses of the two methods, the electric furnace, receiving high voltage current at a certain price, would require transformers and heavy cables from these to the furnace. The carbon electrodes must also be supplied. The blast furnace, on the other hand, has the expense of the blowing engines with their attendant boilers, and of the enormous hot blast stoves for preheating the blast.

*P. L. T. Heroult. Apparatus for smelting iron ore. U. S. patent 815,293, March, 1906. *Electrochemical Industry*, vol. iv., 1906, p. 152.

The furnaces constructed by Heroult and by Keller are so very small in comparison with a modern blast furnace that the general expenses would tell very much more heavily on the electric process. These furnaces moreover need a number of improvements before they reach their most satisfactory and economical design. These improvements will, no doubt, accompany a gradual increase in size, and the electric smelting of iron ores will probably become a commercial fact in localities favorable to its operation.

III.—The Direct Production of Steel from Iron Ore.

It is quite possible to produce malleable iron or steel directly from the ore, by heating the ore with a limited amount of carbon; enough carbon being provided to reduce the oxide of iron to the metallic state, but not enough to leave any excess of carbon, which would unite with the reduced metal to make pig iron. The primitive metallurgists obtained wrought iron and steel in this manner, by reducing the ore in small furnaces, instead of first making pig iron and then turning the pig iron into wrought iron or steel as is the present practice. Iron, nearly free from carbon, is, however, very difficult to melt, and in the little forge or furnace of the savage the iron was not melted, but obtained in the form of a solid lump, which was then cut up and hammered into shape; it being often necessary to pull the furnace down in order to extract the bloom of reduced iron or steel. With larger blast furnaces it is possible to melt even pure iron, but the melted iron will rapidly absorb carbon from the fuel employed, and so will become pig iron. It follows from this and other reasons, that wrought iron and steel cannot be made in a blast furnace. In the electric smelting furnace, however, the conditions are different, because, as the heat is supplied electrically and is not dependent upon the burning of fuel, the amount of carbon supplied can be adjusted exactly to suit the chemical needs of the ore, so as to make a carbon-free iron, or any desired grade of steel.

Captain Stassano has effected this in his electric arc furnace* (Fig. 37), which resembles an open-hearth steel furnace, in which the flame of burning gas has been replaced by the flame of the electric arc. The furnace consists of an iron casing lined with fire-brick, E, and with an inner lining of magnesite bricks,

*Electrochem. Industry, vol. i., pp. 247, 363, and 461; vol. iii., p. 391.
Engineering and Mining Journal, June 15th, 1907, p. 1135.

D. An arc is maintained between the ends G and H of two, nearly horizontal carbon electrodes, the holders of which work through air-tight stuffing boxes in water-cooled casings, J and K. This arrangement prevents the escape of the furnace gases, cools the electrode holders and prevents the oxidation of the external portions of the electrodes. The necessary amount of

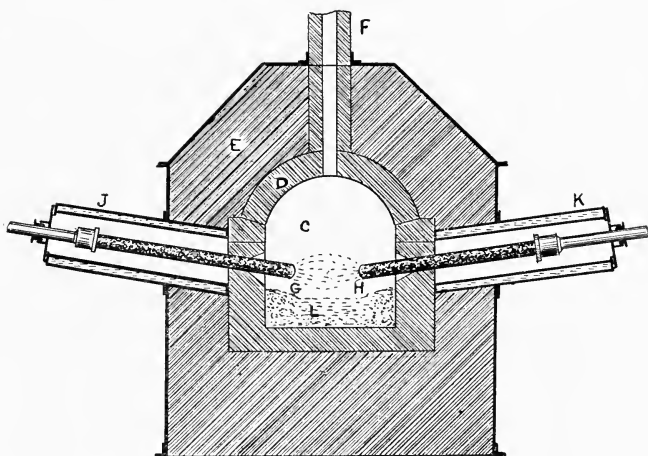

Fig. 37.—Stassano Furnace.

carbon for making iron or steel is incorporated with the ore in the form of briquettes, which are introduced into the furnace, and heated until the chemical reactions have taken place and the reduced metal has melted. The metal and slag are then tapped out and the operation is repeated. The carbon monoxide, resulting from the reaction of the carbon and the ore, escapes from the furnace by the hole F. This waste gas might be employed for drying and preheating the ore.

Dr. Haanel was unable to see Stassano's furnace at Turin, in operation, as it was out of repair at the time of his visit, but he gives a description of the furnace and prints an account of the process written by the inventor.* The newer forms of furnace are inclined about 7° from the vertical and rotate slowly round this inclined axis, with a view to stirring up the charge and allowing the heat of the arc to act more freely on the ore. In some furnaces three electrodes are used, with three-phase current, while in other furnaces four electrodes are employed. Stassano gives the following particulars with regard to a furnace

*Haanel, European Report, 1904, pp. 178-214.

of 1,000 horse-power.* The cost of the furnace is \$5,000, the output per day is 4 or 5 tons, a current of 4,900 amperes at 150 volts is distributed to four electrodes (2,450 amperes to each electrode). The electrodes are 6 inches in diameter and 4 feet to 5 feet long. A five foot electrode weighs 130 lbs., and costs 7 cents a lb. The consumption of electrodes is 22 to 33 lbs. per ton of product, that is 70 cents to \$1 per ton of steel. The lining is of magnesite bricks, and two days are required for repairing the furnace. The lining will last at least 40 days. One man is needed per furnace to regulate the arc; one man for charging two furnaces, and five men for tapping six furnaces. Taking the above figures of 1,000 E.H.P. days for 4 or 5 tons of iron or steel, each ton would need 0.55 to 0.69 horse-power years for its production. Dr. Goldschmidt† investigated the process in 1903 on behalf of the German patent office, and found that it was technically successful, making workably ductile iron with less than 0.2% of carbon directly from pure Italian ores. The energy used was 0.46 to 0.49 horse-power years per metric ton of iron. The process was reported as too expensive to compete with existing methods in Germany.

Comparing the direct process of Stassano with the more usual plan of smelting first to pig iron, and then refining the iron and making steel; it will be seen that the electrical energy needed to smelt ore directly to steel in the Stassano furnace is greater than the energy needed for the other two processes, and that his process was only used with pure ores; while the indirect method allows of the use of any kind of iron ore. The Stassano furnace is intermittent in action, as each charge of ore must be reduced, melted and tapped before a fresh one can be introduced. Moreover the economy of heat is poor because the heat of the escaping gas is not utilized, and its chemical energy is not employed, as it might be, for the reduction or pre-heating of the ore.

The shaft furnace must always be more efficient than a furnace like Stassano's; but if it were found possible to produce good structural steel from impure ores, in an electric furnace of this type, there might be some hope of its commercial success under favorable geographical conditions. Stassano has apparently always used pure ores, and has therefore thrown no light on this point.

*Haanel, European Report, 1904, p. 12.

†Electrochemical Industry, vol. i., 1903, p. 247.

With regard to the possibility of producing pure steel in a single operation from impure ores, the conditions under which the hurtful elements sulphur and phosphorus are removed from iron and steel may be considered. In the blast furnace, sulphur is removed from the iron and passes into the slag as calcium sulphide, its removal in this way being more complete as the furnace is more strongly reducing, and the slag is richer in lime; that is when the conditions are favorable for the formation of calcium to combine with the sulphur. The electric furnace making pig iron has more strongly reducing conditions, and can carry more lime in the slag than is possible in the blast furnace; this explains its superior ability to eliminate sulphur. When, however, the ore is smelted directly to steel in the electric furnace, the conditions are far less reducing, and there is no reason for expecting the removal of sulphur as calcium sulphide, even in the presence of a limey slag. In the open-hearth furnace sulphur can be removed from steel by the action of a basic or limey slag, but not very easily. The conditions in the open-hearth furnace are oxidizing instead of reducing, and the sulphur will be removed as calcium sulphate. In the electric steel furnace the same difficulty may be expected in the removal of the sulphur.

With regard to the elimination of phosphorus the conditions are quite the reverse, as this element can only be removed by oxidation. In the blast furnace any phosphorus in the charge finds its way into the pig-iron, and the same takes place in the electric furnace making pig iron; but in the open-hearth furnace with a strongly basic slag, the removal of phosphorus can be satisfactorily accomplished, and the same will hold good in the production of steel directly from the ore in the electric furnace, if the slag is limey and sufficiently oxidizing.

In this connection some laboratory experiments by Mr. J. W. Evans on the direct production of steel from sulphurous and titaniferous ores possess more interest than would otherwise attach to smelting experiments on so small a scale. From ore containing 1% of sulphur, Mr. Evans obtained samples of steel containing 0.12%, 0.17%, and 0.08% of sulphur. These steels, while not sufficiently free from sulphur for commercial use, show a considerable removal of that element, but as the results were obtained in a small electric crucible holding only an ounce of ore, it seemed doubtful whether they could be depended on to be repeated on a larger scale. There can be little doubt that in an electric steel-making furnace such as the

Heroult or the Stassano in which the molten steel can be washed by the repeated addition and removal of limey slags, any sulphur and phosphorus can ultimately be removed; but as the production of steel directly from the ore can be accomplished most economically in some form of shaft furnace, that is a furnace resembling the Heroult ore-smelting furnace, which is operated continuously, instead of intermittently like the steel furnaces. It was therefore a question of the greatest importance in regard to the possible production of steel directly from the ore, to determine whether in a continuous smelting furnace, steel free from sulphur and phosphorus could be produced from ores carrying the usual proportions of these elements. The experiments of Mr. Evans could not be taken as an answer to this question as his furnace did not operate continuously, and the conditions were decidedly different from those in a continuous furnace. The author accordingly proposed the problem to two of his students, Messrs. W. G. Brown and F. E. Lathe, and embodied the results of their work in a paper read before the Canadian Mining Institute in March, 1907. The experiments were made in a small shaft furnace resembling the furnace used at Sault Ste. Marie, but lined with burnt magnesite. As no carbon could be used as a lining for the crucible of the furnace, electrical connection was made by means of an iron rod passing through the bottom of the furnace. The power available was rather small, but it was found possible to run the furnace regularly for a few hours at a time, producing low-carbon steel of which some two or three pounds were tapped at intervals of about half an hour.

The ore used was a pure hematite from Lake Superior, containing 97% Fe_2O_3 , 2.23% of silica, and 0.68% of alumina. Clay, sand, and lime were added to make a slag equal to about half the weight of the resulting metal, and 1% each of sulphur and phosphorus was added in the form of monosulphide of iron and calcium phosphate.

Analyses of the steel and slag from a number of the taps are given in table xiii., and show very clearly the effect of lowering the carbon in the charge, and so producing steel instead of pig iron. If sufficient carbon had been added in the charge, a pig iron would have been produced rich in carbon and silicon, low in sulphur, and with more than 1% of phosphorus. With the smaller amount of carbon which was charged in these experiments, the resulting iron contained less carbon and silicon and more sulphur, (see No. 1 in the table). As the carbon in

the charge was diminished, the resulting metal contained still less carbon and silicon, and at the same time the phosphorus in the steel was progressively reduced, until in the lowest carbon steels the phosphorus became low enough for structural purposes. The sulphur, on the other hand, which would have been nearly eliminated in the production of pig iron, increased with the decrease of carbon, no doubt because there was less opportunity for its removal as calcium sulphide; but further decrease of carbon, resulting in a highly oxidised slag, served to remove a portion of the sulphur, probably a calcium sulphate, in the same way that it is removed in the basic open-hearth furnace.

TABLE XIII.
Steel and Slag Analyses.

	%	%	%	%	%	%	%
Steel.	1	2	3	4	5	6	7
C	2.09	1.16	.54	.088	.088	.088	.091
Si20	.15	.24
S75	.91	1.04	.54	.65	.68	.47
P49	.24	.20	.039	.046	.081	.031
Slag.	%	%	%	%	%	%	%
FeO	4.5	7.1	3.6	20.54	20.64	26.94	33.46
SiO ₂	31.7	30.3	32.2	16.77	18.92	15.66	15.42
CaO	30.7	30.8	36.0	27.07	35.17	35.17	32.54
MgO	15.8	21.3	17.6	22.34	13.90	13.84	11.34
Al ₂ O ₃ . . .	13.2	9.3	11.7	7.48	5.30	3.53	2.13

The first three analyses are taken from one run of the furnace, while the last four are from another run, in which less carbon was charged. The second run appears to show that the carbon in the steel could be lowered to about 0.09 per cent., but that any further reduction in the amount of carbon charged, merely increased the already large percentage of iron oxide in the slag, without lowering any further the carbon in the steel. Mr. Evans appears to have had still more oxidising conditions, reducing the carbon in his steel to 0.06 per cent., with a corresponding reduction in the sulphur, which he succeeded in lowering to 0.08 per cent. in one experiment. The lowest sulphur in the present series of experiments was 0.34 per cent.

While these analyses only represent the result of smelting an iron ore in an electric furnace with particular conditions of charge, shape of furnace, current density, etc., and changes in

any of these conditions might influence the composition of the resulting steel, they indicate pretty clearly that in the electrothermic production of steel directly from a sulphurous ore, it will not be easy to remove the sulphur in an electric furnace, operating continuously like a blast furnace; although it may be possible with intermittent operation, as in an electric open-hearth furnace. Phosphorus, on the other hand, can be satisfactorily removed when low carbon steel is produced.

At present the most satisfactory process for making steel electrically from iron ore, is to smelt electrically to pig iron in a shaft furnace, thus eliminating the sulphur; transfer the molten pig to an electric open-hearth furnace and there remove the excess of carbon, silicon, etc., and the phosphorus. If the shaft furnace could produce a nearly pure iron directly, so that the second furnace would be little more than a ladle for adjusting the composition, a decided economy should be effected. A combination of electric shaft furnace for making pig iron, and electric refining furnace for converting this into steel has been described by Keller.*

In smelting iron ores to obtain a low carbon product, the carbon electrodes, if in contact with the slag or melting ore, will be liable to more rapid corrosion than when smelting for pig iron; on account of the scarcity of carbon in the charge. This difficulty, if it were found to be serious, might be overcome by the use of a furnace like that of De Laval (Fig 18, p. 29), in which the reduced and melted metal, collecting in two troughs, serves as the electrodes; electrical contact being made with the molten metal by solid rods of the same material. Another plan for avoiding the use of carbon electrodes, is to employ the induction principle, as in the Snyder Induction furnace, Fig. 47, or in some Swedish ore-smelting furnaces† which have a shaft for the reduction of the ore, while the molten pig iron, resulting from the operation, collects in an annular channel where it is heated by an induced electric current. The cost of producing low carbon steel direct from pure Italian ore, in the Stassano furnace, has been estimated by Dr. Goldschmidt, who sets the cost of a ton of such steel at \$18.80. The furnace does not utilize the heat of the current very perfectly, and with improved furnaces and better conditions for the purchase of general supplies, a lower figure might be expected.

*Electrochemical Industry, vol. i., 1903, p. 162, and Journal of Iron and Steel Institute, 1903, No. 1, p. 161.

†Dr. Haanel, 1907 Report, p. 104.

CHAPTER VI.

Other Uses of the Electric Furnace.

The production of iron and steel in the electric furnace is still in its infancy; and will be limited by the price of electrical energy. But there are many other uses to which this source of heat has long been profitably applied, as has been indicated in the first two chapters. In some of these processes, electrical heat is alone able to produce the required result, while in others the value of the product and the greater economy of the electrical method has enabled it to supplant the older processes, even though the latter employed cheap fuel as the source of heat. Some of these uses of the electric furnace will now be considered, and they have been placed for convenience under the following heads:—

1. The Ferro-Alloys.
2. Graphite and the Carbides.
3. Electrothermic Production of Zinc.
4. Miscellaneous uses of the Electric Furnace.
5. Electrolytic Furnace Operations.

I.—The Ferro-Alloys.

The Ferro-Alloys.—The alloys of iron with certain metals, such as manganese, chromium, tungsten and titanium, or with the metalloid silicon, are often known as the ferros, and are usually equivalent to cast iron, that is iron with a large percentage of carbon, in which part of the iron has been replaced by one of the above metals or metalloids. In some cases, however, carbon is present only in small amounts or not at all, and, on the other hand, more than one of the alloying metals may be present in the same ferro. The ferros are used in the production of steel as convenient means for introducing into the steel the manganese or other metal which they contain; it being usually less costly to obtain these metals as ferro alloys than in the pure state, and the presence of the iron is not objectionable in additions made to steel; although the carbon, which is also usually present, is sometimes undesirable.

The metal manganese resembles iron in many particulars, but is more difficult to reduce from its ores, and when this is effected in the blast furnace, with iron ore to furnish enough

iron to collect and alloy with the manganese, some $2\frac{1}{2}$ or 3 tons of coke are required to produce one ton of the 80 per cent. ferro-manganese, and about 20 per cent. of the manganese is lost in the slag owing to the imperfect reduction of the ore. Such an operation is very wasteful, both in fuel and in the valuable manganese ore, and the electric furnace is so much more economical in both these particulars, that it can be used in competition with the blast furnace method. Silicon-eisen, that is low-grade ferro-silicon containing some 10 or 15 per cent. of silicon, can be made in the blast furnace by using silicious charges and a great excess of fuel, the silicon being derived from the silica in the charge. In the electric furnace, however, using quartz as the source of silicon, with coke to reduce the quartz to the metallic state, and some iron ore or scrap iron to alloy with the silicon, an alloy containing as much as 80 per cent. of silicon may be obtained; and the electric furnace ferro-silicon has largely displaced the blast furnace product, as the cost of the former, per unit of silicon, is so much less. Some other ferro-alloys are also made more cheaply in the electric furnace.

The ferro-alloys may be produced in electric crucible furnaces, such as the Siemens vertical arc furnace, Fig. 2, p. 4, or the Heroult ore-smelting furnace, Fig. 29, p. 108, in which a carbon electrode dips into a carbon-lined receptacle, which forms the other electrode. In such a furnace the alloy will usually absorb a considerable amount of carbon from the lining, and if a carbonless alloy is required, a furnace like the Heroult steel furnace, Fig. 23, p. 87, should be used, in which two carbon electrodes are employed, which need not touch the molten metal, and the lining of the furnace is not made of carbon.

The electro-metallurgy of silicon is described by Albert Keller,* who states that at Livet, with 4,000 H.P., he was able to turn out 20 tons of 30 per cent. ferro-silicon per day, and that one ton of the alloy requires 3,500 kilowatt hours for its production from quartz, scrap iron and coke, the furnaces being each of 650 H.P.

The production and probable uses of ferro-titanium are discussed by Auguste J. Rossi,† who reduces tinfiferous iron ores in the electric furnace, either with carbon or with the as-

*Keller, Journ. Iron and Steel Inst., 1903, vol. i., p. 106.

†Rossi, Mineral Industry, vol. ix., 1903, p. 715, and Trans. Am. Inst. Min. Engs., vol. xxxiii., 1903, p. 191.

sistance of molten aluminium, which serves to reduce the metal from its ore. He has obtained alloys with from 10 to 75 per cent. of titanium, which, when aluminium was used as the reducing reagent, only contained a few tenths of one per cent. of carbon. Rossi states that titanium is not really such a bugbear to the iron metallurgist as is usually supposed, but that on the contrary ferro-titanium, added to either pig iron or steel, markedly improves the mechanical properties of the metal. In the case of steel he suggests that the well-known property of titanium of combining with nitrogen may enable it to remove this gas from the molten metal, and in this way to improve its quality. A company has recently been formed to manufacture ferro-titanium in the electric furnace, and is building a plant at Niagara Falls.*

The manufacture of ferro-nickel, ferro-chrome and other alloys of iron that are used in the production of steel are described by O. J. Steinhart.† Ferro-chrome, containing from 50 to 60 per cent. of chromium, was made at one time by heating chromite with charcoal in crucibles, and later in small blast furnaces, but is now made, almost entirely, in the electric furnace. The Willson Aluminium Company employed 4,000 E.H.P., and turned out 200 to 250 tons per month of ferro-chrome having 5 to 6 per cent. carbon and over 70 per cent. chromium. Their works at Kanawha Falls, W. Va., and their business and patents relating to the manufacture of the ferro-alloys have been acquired by the Electrical Metallurgical Company,‡ who also have works at Niagara Falls.§

The Girod Ferro-Alloy Works have been described by Dr. R. S. Hutton,|| who draws attention to the wonderful development of the hydro-electrical installations in the French Alps and the application of this power to electro-metallurgy. The three works of the Societe anonyme Electrometallurgique. Precedes Paul Girod, have the following annual output:—

- 5,000 tons of 50% ferro-silicon.
- 1,000 tons of 30% ferro-silicon.
- 2,000 tons of ferro-chromium.
- 800 to 900 tons of ferro-tungsten.
- About 50 tons of ferro-molybdenum.
- 5 to 10 tons of ferro-vanadium.

*Electrochemical Industry, vol. v., p. 69.

†Steinhart, Trans. Inst. Min. and Met., vol. xv., 1906, p. 228.

‡Electrochemical Industry, vol. v., p. 248.

§Electrochemical Industry, vol. v., p. 69.

||R. S. Hutton, Electrochemical Industry, vol. v., p. 9.

The value of the alloys sold is more than \$1,800,000 per annum. Two grades of ferro-tungsten are produced, "The one containing about 85% tungsten, and a maximum of 0.5% carbon, is chiefly employed in the manufacture of crucible tool steels. The other quality containing 60%-70% tungsten, and 2%-3% carbon is largely used for the manufacture by the open-hearth process of steels containing less than 2.5% tungsten, which are used for the manufacture of springs, etc." Analyses of typical products of these works are contained in Table XIV.

TABLE XIV.

Analyses of Ferro-Alloys.

	Ferro-manganese (blast furnace).		Spiegel-eisen (blast furnace).		Silicon-spiegel (blast furnace).
	%	%	%	%	%
Manganese	82.00 ²	80.00 ³	20.40 ²	15.00 ³	19.00 ³
Iron	9.90	12.03	73.20	79.93	66.17
Carbon	6.58	6.80	5.00	4.30	1.65
Silicon	1.00	0.90	1.10	0.50	13.00
Sulphur	Trace	0.02	Trace	0.02	0.08
Phosphorus	0.12	0.25	0.06	0.25	0.10
Arsenic	0.10		0.10		

	Ferro-silicon, Blast-furnace.		Electric-furnace.	
	%	%	%	%
Silicon	14.85 ³	78.80 ⁴	59.40 ⁵	31.90 ⁴
Iron	82.95	12.64	36.85	61.30
Manganese	0.34	0.30	0.08	3.92
Aluminium		4.76	2.73	0.22
Calcium		2.32	0.14	0.79
Magnesium		0.22	0.17	0.26
Carbon	1.66	0.55	0.218	0.50
Sulphur	0.08	0.008	Trace	0.055
Phosphorus	0.12	0.051	0.056	0.027
Chromium		0.16		1.02
Copper		0.04		0.01
Tungsten		0.00		0.25

2. F. W. Harbord, *The Metallurgy of Steel*, p. 53
 3. P. Longmuir, *Elementary Practical Metallurgy, Iron and Steel*, p. 81.
 4. G. W. Gray, *Journ. Iron and Steel Institute*, 1901, No. 2, p. 144.
 5. G. W. Gray, *Journ. Iron and Steel Institute*, 1904, No. 1, p. 32.

Ferro-chromium.

	Crucible furnace.		Electric furnace. ¹			
	%	%	%	%	%	%
Chromium	45.0	60.00	67.20	64.17	67.05	65.90
Iron	45.0	30.00	31.35	32.47	27.05	23.44
Carbon	8.6	9.1	0.90	2.34	4.25	8.58
Silicon	0.6	0.5	0.19	0.38	0.60	1.26
Manganese	0.4	0.3	0.12	0.21	0.46	0.44
Aluminium	0.0	0.0	0.00	0.13	0.22	0.18
Magnesium	0.0	0.0	0.19	0.23	0.31	0.14
Sulphur	0.05	0.05	0.006	0.023	0.02	0.02
Phosphorus	0.05	0.05	0.021	0.02	0.02	0.02

Ferro-tungsten,
(Electric furnace).¹

	%	%
Tungsten	85.15	71.80
Iron	14.12	24.35
Carbon	0.45	2.58
Silicon	0.13	0.36
Manganese	0.085	0.78
Sulphur	0.021	0.02
Phosphorus	0.018	0.008

Ferro-vanadium,
(Electric furnace).¹

	%	%
Vanadium	52.80	34.10
Iron	45.84	64.22
Carbon	1.04	1.42
Silicon	0.09	0.12
Aluminium	0.00	0.00
Sulphur	0.025	0.03
Phosphorus	0.02	0.009

Ferro-molybdenum,
(Electric furnace).¹

	%	%
Molybdenum	79.15	83.80
Iron	17.52	12.72
Carbon	3.24	3.27
Sulphur	0.021	0.02
Phosphorus	0.028	0.027

In dealing with these and other products of the electric furnace, it should be remembered that they will sometimes evolve explosive gases if allowed to come in contact with water. This may be due in some cases to small quantities of calcium carbide formed at the high temperature of the electric furnace, but in one case, that of some ferro-silicon, which produced a number

1. R. S. Hutton, *Electrochemical Industry*, vol. v., p. 10.

of explosions in Liverpool a few years ago,* the explosive gas was found to be phosphoretted hydrogen. The alloy was very pure, containing nearly 60 per cent .of silicon, with 2.7 per cent. of aluminium, 0.2 per cent. of carbon, 0.14 per cent of calcium, 0.17 per cent. of magnesium, and 0.56 per cent of phosphorus.

Manganese, nickel, chromium, tungsten and other metals can also be obtained in a carbon-free and nearly pure state, suitable for use in the manufacture of special varieties of steel, by the Goldschmidt process of mixing the oxide of the metal with powdered aluminium and igniting the charge by means of a small primer, which starts the reaction between the oxide and the aluminium. The reaction once started continues throughout the mass, producing an intense heat, which is sufficient to melt the reduced metal and the resulting alumina.

The metalloïd silicon, on account of its strong affinity for oxygen, can be used instead of aluminium for the reduction of such metals as chromium, tungsten and molybdenum from their oxides, and for obtaining alloys of these metals with iron or nickel. Mr. F. M. Becket† has patented this process, and describes the production of ferro-chrome, low in carbon and silicon, by feeding a mixture of chromite and metallic silicon into an electric furnace. The oxides of iron and chromium, contained in the chromite, are reduced to the metallic state by reacting with the silicon according to the following equations:—

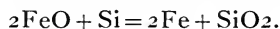
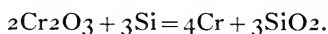

The silica resulting from the reaction is slagged off by the basic impurities present in the chromite. An excess of the chromite is used to prevent any of the silicon remaining unoxidized and alloying with the ferro-chrome.

Mr. Becket‡ also patents the use of silicon or ferro-silicon for reducing metals, particularly the metals molybdenum and vanadium, from their sulphide ores. The following equation shows the action when silicon and molybdenite are used:—

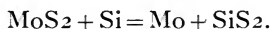

*A. Dupre and M. B. Lloyd, Journ. Iron and Steel Inst., 1904, No. 1, p. 30.

†F. M. Becket, U.S. patent 854,018, Electrochemical Industry, vol. v., p. 237.

‡F. M. Becket, U.S. patent 855,157, Electrochemical Industry, vol. v., p. 237.

Mr. E. F. Price* has also secured a patent for the production of low-carbon ferro-chromium, etc., by the use of ferro-silicon. He obtains ferro-silicon in an electric furnace and then taps it into a second electric furnace, where it is made to react with the chromite, for the production of ferro-chrome.

II.—Graphite and the Carbides.

Graphite :—The elementary substance carbon exists in nature in three distinct forms:—Amorphous Carbon, Graphite and the Diamond. Amorphous carbon exists in a nearly pure state in such substances as charcoal, lampblack, petroleum-coke, and the ordinary electric light carbons. Graphite derives its name from its property of writing on paper, and is largely used for this purpose in the common “lead pencil.” Plumbago and black-lead are other names for graphite, which date from a time before the true nature of graphite had been discovered, and when it was supposed to be closely related to lead and certain of its ores.† Natural graphite is classified as crystalline and amorphous, the former occurs in flakes or flakey masses and can easily be freed from associated earthy matter, while the latter, which must not be confused with amorphous carbon, mentioned above, does not occur in flakes, and is therefore not so easily separated from the clayey and other impurities with which it is frequently intimately associated.‡ Crystalline graphite is largely used in the manufacture of pencils, crucibles and lubricants, while the less valuable amorphous graphite is utilized for paints and foundry facings. The graphite from the Borrowdale mines in Cumberland, although amorphous, was famous for many years as the best for making pencils; being of great purity.

The diamond, the remaining form of carbon, is remarkable for its great hardness, its crystalline form, and its transparency when pure. It has been produced artificially by crystallization under pressure from a solution of carbon in molten iron, but the process has not attained any commercial success.§

Graphite differs from amorphous carbon in the following particulars:—It has a somewhat higher specific gravity, it is a

*E. F. Price, U.S. patent, 852,347, *Electrochemical Industry*, vol. v., p. 278.

†Graphite: its formation and manufacture, by E. G. Acheson, *Journ. Franklin Institute*, 1899.

‡Graphite, by E. K. Judd, *Mineral Industry*, vol. xiv., p. 309.

§Artificial diamonds, *Electrochemical Industry*, vol. iv., p. 343.

better electrical conductor, and is less easily oxidized by air at a red heat or by certain chemical reagents. Its greater resistance to oxidation enables it to be used in the manufacture of crucibles, and this and its good electrical conductivity render it valuable as a material for electrodes for various electro-chemical and electric-furnace operations.

It has been known for a long time that amorphous carbon and the diamond could be converted into graphite by exposure to very high temperatures and in other ways. The conversion of amorphous carbon into graphite by the action of heat is only accomplished at the highest temperatures of the electric furnace, and even then not readily.* When, however, some metal like iron or nickel, which has the property of dissolving carbon when in the molten state, is saturated with that substance, and then allowed to cool slowly, the carbon will crystallize or separate from the cooling metal as flakes of graphite. The separation of graphite from molten pig-iron can be very easily noticed in a blast-furnace casting house. The method by which large amounts of graphite are now artificially produced depends on the formation of carbides of iron, silicon, etc., and the subsequent decomposition of these carbides at a still higher temperature, the iron, etc., being driven off in the state of vapor, leaving the carbon in the form of graphite and of a high degree of purity.

The decomposition of carbide of silicon yielding graphite in the hottest part of the carborundum furnace had been noticed by Mr. Acheson who investigated the matter and found that pure forms of carbon were only slightly changed into graphite in the electric furnace, but that impure carbon such as ordinary coke, or carbon to which certain substances such as iron oxide, silica, or alumina had been added, were largely converted into graphite. Mr. Acheson patented the electric-furnace production of graphite in 1896† and its commercial development has been so rapid that in 1905 the production of artificial graphite was greater than the whole output of natural crystalline graphite in the United States.

*F. J. FitzGerald. The conversion of amorphous carbon to graphite, Journ. Franklin Institute, 1902.

†E. G. Acheson, U.S. patent 568,323, Sept. 29, 1896. Converts carbonaceous materials such as mineral coal, coke, charcoal, gas-carbon and carbides into practically pure graphite, by employing a material containing a considerable proportion of mineral matter, or mixing it with an oxide or oxides, such as silica, clay, alumina, magnesia, lime or iron oxide, and heating the mixture in an electric furnace, *Electrochemical Industry*, vol. iii., p. 482.

The electric-furnace production of graphite* is illustrated in Figs. 38 and 39. The former showing a furnace for the conversion of anthracite into bulk graphite, while the latter illustrates the graphitization of electrodes or other articles of amorphous carbon.

Anthracite has been selected as the most suitable material for the production of graphite in bulk. The impurities which are disseminated through it serving as carbide-forming materials which render possible its conversion into graphite. The graphite furnace consists, as is shown in Fig. 38, of a long trough which contains the anthracite, and of two electrodes which are situated at the ends of the furnace. As the cold anthracite is a very poor conductor of electricity, a core, C, of carbon rods is needed to carry the current, until the charge becomes heated. The furnace consists of a permanent base, B, and end walls, AA, which support the electrodes. The side walls, DD, are not permanent but can be pulled down after a run. The base of the furnace is shown supported on bricks so as to allow of air-cooling, but this precaution is not always taken. The electrodes are made of a number of graphite rods, E, which are set in a block of carbon as shown in the sketch; electric contact being made by a terminal plate, L, which may be water-cooled. Above the charge of anthracite, H, is placed a cover, K, of some good heat-insulating material, which should also be a very poor conductor of electricity.

In an account of this furnace written in 1902 by Prof. J. W. Richards,† it is said to be 30 feet long and formed of a trough 2 feet square, lined on bottom and sides with blocks of compact carborundum 6 inches thick. Such a furnace held a charge of about 6 tons of anthracite coal, ground to the size of rice, and this was graphitized in twenty hours. The author is informed by the Acheson Graphite Company that no refractory lining is now employed. As the temperature of formation of graphite in this furnace is almost certainly over 2,000°C., it must be well above the melting point of ordinary fire-clay bricks, and a furnace such

*E. G. Acheson, U.S. patent 645,285, March 13, 1900, Producing graphite by heating anthracite, etc., *Electrochemical Industry*, vol. iv., p. 42.

Manufacturing graphite, British patent 2,116, of 1901, by O. Imray, of the International Acheson Graphite Company, *Electrochemist and Metallurgist*, vol. i., p. 131.

Manufacturing of artificial graphite from charcoal, J. Weckbecker, illustrated account, *Electrochemical Industry*, vol. ii., p. 244.

Process of Making Graphite, E. G. Acheson, U.S. Patent, 711,031, *Electrochemical Industry*, vol. i., p. 130.

†The Electrochemical Industries of Niagara Falls, J. W. Richards, *Electrochem. Industry*, vol. i., p. 52.

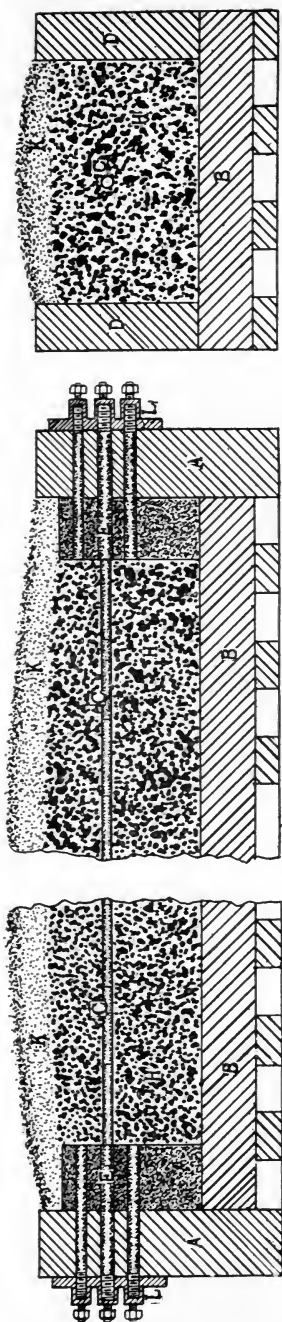

Fig. 38. Acheson's Graphite Furnace.

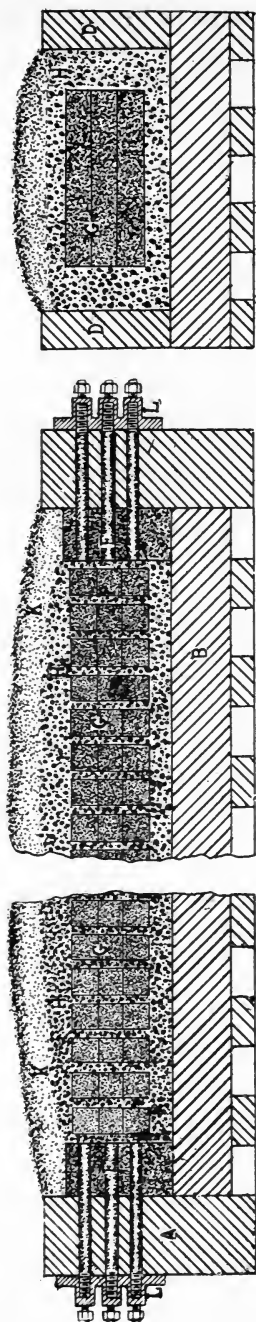

Fig. 39. Acheson's Electrode Furnace.

as is shown in Fig. 38 could only be operated if the bottom and walls were composed of or lined with some specially refractory material, or if it were possible to leave a layer of unconverted anthracite between the furnace walls and the remainder of the charge.

By increasing the cross section of the charge there would be less danger of the walls becoming overheated and the graphitization of the central portion of the anthracite might still be effected provided the electric current could be concentrated on this portion instead of spreading over the whole of the cross section. At the beginning of the run the current will pass almost entirely through the core of carbon rods, and when this conducting core is augmented by the conversion of the surrounding anthracite into graphite, its electrical resistance will become so low that there will be little tendency for the current to pass through the outer portions of the charge.*

The electrode furnace,† Fig. 39, resembles the graphite furnace in construction. The electrodes or other articles to be graphitized are placed in piles with their length across the length of the furnace, in order to keep the electrical resistance as high as possible. They are surrounded by broken coke, which has a moderately high resistance, so that most of the heat is developed in the parting layers of coke, and the current will tend to pass through the electrodes in the middle of the furnace, rather than through the outer parts of the furnace which are filled with the broken coke. The coke will consequently serve as a jacket to retain the heat and prevent the overheating of the walls of the furnace. The dimensions of the furnace depend upon the size of the electrodes, which can be as much as 4 feet in length. A cover of some heat-insulating substance is employed, but there is no refractory lining of carborundum, etc., such as was described in the patents and earlier accounts.

In the plant of the International Acheson Graphite Company at Niagara Falls there are 6 furnaces of 750 or 800 K.W., and 10 furnaces of 1,600 K.W. The total power employed is

*Compare the account of the manufacture of soft graphite, where an outer portion or jacket of poorly conducting material is provided.

†Graphitizing electrodes and other carbonaceous articles. Patent application, November 23rd, 1900, with illustration of electrode furnace. *Electrochemist and Metallurgist*, vol. i., 1901, p. 54.

The Ruthenburg and Acheson Furnaces, F. A. J. FitzGerald, *Electrochemical Industry*, vol. iii., p. 417.

E. G. Acheson U.S. patent 617,979, January 17th, 1899, and 702,758; June 17th, 1902, Graphite electrodes, etc. Mentions current and size of furnace, *Electrochemical Industry*, vol. iv., p. 42.

2,400 K.W., operating one furnace of each size; the other furnaces being in process of cooling, emptying or recharging. Each furnace takes about half a day to heat, and four or five days to cool. The total output of the plant in 1906 being nearly 6,000,000 lbs. of graphite. The electrical current is supplied at a voltage of 2,200. This is transformed to a current at 200 volts, and the voltage is further lowered by a special regulator as the resistance of the charge decreases during the run, so that all the available power can be applied during the whole period. J. W. Richards states that for the electrode furnaces the current is 3,000 amperes at 220 volts to begin with, and 9,000 amperes at 80 volts at the end of the operation. The current flowing through the 1,600 K.W. furnaces must be about twice as large as this.

The conversion of amorphous carbon into graphite in the Acheson furnace is supposed to be due to the formation and subsequent decomposition of carbides of the iron and other metals contained in the charge. It should be noted, however, that the amount of iron, aluminium, calcium, etc., contained in the anthracite, or specially added to the electrodes, is not nearly enough to combine with all the carbon to form carbides, as the ash or impurity in anthracite varies from about 5% to about 15%. and the amount of iron ore, etc., which is added to the electrode material in order to enable the manufactured electrode to be graphitized is only 2% or 3%. These metals may be expected to serve for more than one equivalent of carbon, because when the central part of the furnace has become hot enough to dissociate the carbides that had formed there, the volatilized metals will escape to cooler zones, and will again form carbides with the carbon at that point; but this explanation hardly accounts for all the carbon that is graphitized through the agency of a very small amount of added metal, although it undoubtedly explains in part the great effect of these added bodies. Another factor will be found in the consideration that dissociation and reformation of the carbides is always taking place at temperatures below that of the final splitting up of these bodies, and that in this way the small amount of metal can eventually form carbides with all the carbon in the furnace. From this point of view, time would appear to be an essential element in the conversion of carbon into graphite, and this is probably the case, although at the high temperature of the graphite furnace these molecular combinations and dissociations will, no doubt, take place with great rapidity.

The character and uses of Acheson graphite are fully described in a series of pamphlets issued by the International

Acheson Graphite Company,* and in other published papers,† from which the following points may be summarized. The real density of natural graphite, and of the Acheson graphite electrodes is 2.25, while the real density of amorphous carbon varies from 1.5 to 1.9. The graphite electrodes are very pure containing certainly less than 1%, and often only 0.1% of impurity.‡ The electrical conductivity of the graphite electrodes is about four times that of amorphous carbon electrodes, and the cross section of an electrode can be proportionately decreased when the graphite variety is employed. Graphite electrodes are found to have a far longer life than those of amorphous carbon when used in a variety of electrolytic processes; the rate of corrosion and disintegration being very much less.§ The graphite electrodes have another valuable property, namely, that of easy cutting or machining.|| Electrodes of amorphous carbon are very difficult to cut, and must usually be moulded into any required shape, while the Acheson graphite electrodes can be cut with a saw, drilled, threaded, etc., so that all kinds of shapes can readily be prepared from rods or slabs of the graphite. In particular, it is possible to avoid wasting the ends of electrodes, by the use of threaded connections, as in Fig. 32, so that when an electrode becomes too short for further use, another is attached to its outer end, and the lengthened electrode can be fed steadily forward into the furnace or electrolytic tank without interruption of the process or waste of electrode. In electrolytic work, composite electrodes are often used; a slab of graphite serves as the working electrode, being immersed in the electrolyte, and one or more graphite rods which are threaded into the slab, serve to support it and lead in the electrode current.

*Acheson Graphite Electrodes. Pamphlet by The International Acheson Graphite Company.

†Graphite Electrodes in Electrometallurgical Processes. C. L. Collins, Amer. Electrochem. Soc., vol. i., p. 53.

‡Uses of Acheson Graphite in Metallurgical Research, W. McA. Johnson, Electrochemical Industry, vol. ii., p. 345.

§Graphite electrodes for electric furnace work, Electrochemical Industry, vol. iv., p. 513. The Acheson Graphite Company supplied 2,404,171 pounds of graphitized electrodes during the year ending July 1st, 1906.

||The pamphlet on Acheson Graphite Electrodes, dated 1902, states that the percentage of impurities averages about 1 part in 1,000, and quotes an experiment in which their electrodes yielded 0.8 per cent. of ash. A later leaflet on Acheson Graphite states that the electrodes contain 99.5 per cent. of pure graphitic carbon.

§Graphite Electrodes in Electrolytic Work, by C. L. Collins, Electrochemical Industry, vol. i., p. 26.

||Adaptability of Acheson Graphite Articles, or Ease of Machining. Acheson Graphite Company, 1904, and paper by C. L. Collins, Electrochemical Industry, vol. ii., p. 277.

Mr. Acheson has recently succeeded in producing a specially soft variety of graphite which is found to be a very efficient lubricant.*

It is made in the electric furnace from anthracite or other form of amorphous carbon to which a larger amount than usual of carbide forming material has been added. Silica is preferred as an addition, because it does not form a fusible carbide. The amount added being far greater than is added in the manufacture of graphite electrodes, or is present in the conversion of anthracite into bulk graphite, but it is less than would be required for making a carbide with the whole of the carbon. The following specific case is contained in the patent application :†—

“An electric furnace, having a length of 18 feet between terminal electrodes, was provided with a starting core consisting of a graphite rod $\frac{7}{8}$ -inch in diameter. The active zone, 18 inches in diameter, surrounding this core was filled with a mixture of carbonaceous material and carbide-forming oxide. The materials used in this specific instance were anthracite coal, ground to pass through a $\frac{1}{2}$ -inch mesh, mixed with sand, in the proportion of 65 per cent. coal and 35 per cent. sand, the ash contained in the coal being calculated as a part of the sand content of the mixture. Completely surrounding the active zone above referred to was disposed a mixture of anthracite coal and sand in the proportion of 1 part coal to 2 parts of sand, this mixture having a much higher resistance than that in the active zone, and serving as an effective heat retainer. The furnace being charged in this manner the electric current was turned on, and at the beginning registered 79 volts and 75 kilowatts. After 2 hours, the register showed 203 volts and 200 kilowatts, and after $9\frac{1}{2}$ hours showed 135 volts and 800 kilowatts. The register at the end of 15 hours still showed 800 kilowatts, while the volts had dropped to 70, as the result of decreased internal resistance, due to the formation of graphite. When cold the furnace was opened and 962 pounds of soft, unctuous and non-coalescing graphite were removed from the active zone.”

Kryptol,‡ a specially prepared material for use as a resistor in electric heaters and furnaces, appears to consist of a mixture of graphite and amorphous carbon, in grains of nearly uniform size. This material can be given a higher or lower electrical conductivity by varying the proportion of graphite and amorphous carbon, and by changing the size of the grains of which the material is formed.

Carborundum. The discovery of this carbide by E. G. Acheson in 1891,§ was the first step leading to the considerable industries at Niagara Falls, with which he is now associated.

*Soft Graphite, *Electrochemical Industry*, vol. iv., pp. 343, and 502.

†Soft Graphite. E. G. Acheson, U.S. Patent 836,355, *Electrochemical Industry*, vol. iv., p. 502.

‡Kryptol, *Electrochemical Industry*, vol. ii., pp. 333, and 463, vol. iii., pp. 5, 127, and 157, and vol. iv., pp. 148, 210, 250, 296, and 344.

§See page 10.

The metal silicon is perhaps the most abundant metal in the world, forming nearly 50% of the widely spread substance silica, which is the oxide of silicon. Its affinity for oxygen is so great, however, that until the advent of the electric furnace it could only be isolated with the greatest difficulty. In the higher ranges of temperature afforded by the electric current, the metal is not only readily reduced from its oxide by means of carbon, but the reduced metal combines with carbon to form a carbide having the formula SiC. This carbide is amorphous when it is first formed, but on being more strongly heated it crystallizes and is then known as carborundum. The formation of the carbide may be represented by the following equation:—



Carborundum is produced by heating a mixture of coke, silicious sand, sawdust and salt in an electric furnace such as is shown in operation in Fig. 40, and diagrammatically in Fig. 8, p. 11. The charge is made approximately in the following proportions:—Coke, 34.2%; sand, 54.2%; sawdust, 9.9%; and salt, 1.7%; the sand and the carbon in the coke and sawdust being nearly in the proportion indicated by the equation. The sawdust contained in the charge has the effect of rendering it more porous and of allowing the gases to escape more freely, while the salt is found to facilitate the running of the furnace.

Later accounts show a larger proportion of salt and a smaller amount of sawdust in the charge. J. W. Richards,* writing in 1902, and describing a furnace of 750 K.W., says, "The total contents of the furnace are about 1,000 pounds of carbon core, and the mixture reduced represents 3.5 tons of carbon mixed with 6 tons of silica sand and 1.5 tons of salt, producing in a thirty-six-hour run between 3 and 4 tons of commercial carborundum, in crystals, outside of which is a quantity of light-green amorphous carborundum, fully reduced, but uncrystallized, and outside of this the unchanged mixture." E. G. Acheson's United States patent No. 560,291, May 19th, 1896,† for a carborundum furnace of 1,000 K.W. specifies a mixture of "20 parts (by weight) of finely divided coal or coke, 29 parts of sand, 5 parts of common salt, and 2 parts of sawdust."

*The Electrochemical Industries of Niagara Falls, J. W. Richards, *Electrochemical Industry*, vol. i., p. 50.

†E. G. Acheson, U.S. patent 560,291, *Electrochemical Industry*, vol. v., p. 79
An earlier patent, 492,767, February 28th, 1893, is abstracted in vol. v., p. 36.

The mixture of coke, sand, etc., is not a good conductor of electricity, and the heating must therefore be effected by means of a core of broken coke, marked E in Fig. 8, which extends between the two electrodes, C and D, and serves as a resistor, carrying the electric current and heating the surrounding charge.

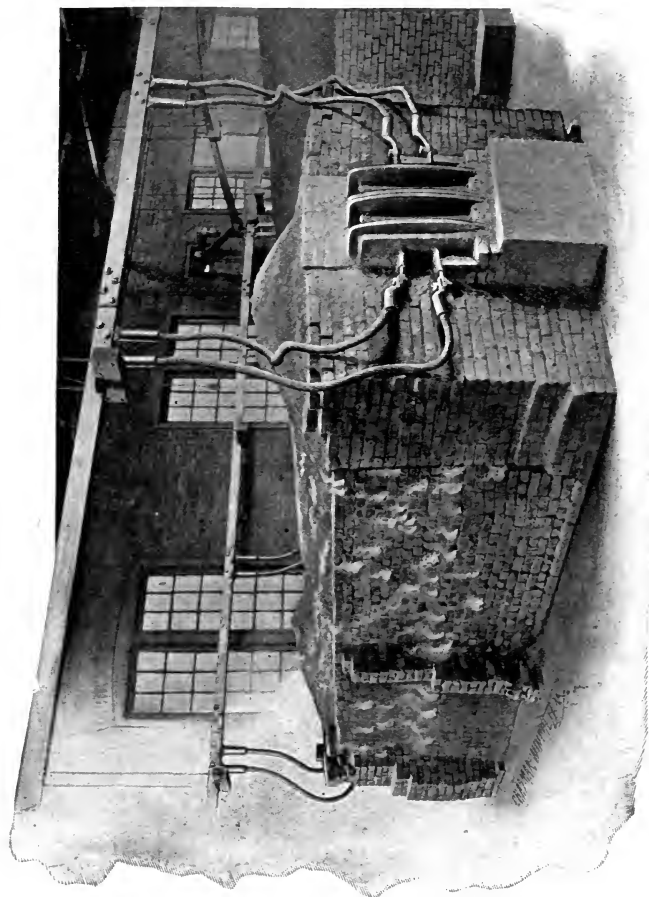

Fig. 40.—Carborundum Furnace Burning.

The coke for making up the charge is ground to a powder, but the coke for the resisting core is in small pieces about $\frac{1}{4}$ or $\frac{3}{8}$ inch in size, from which the dust has been removed. The core is circular in section and is built up by hand after the furnace has been half filled, a packing of fine carbon powder serves to make good electrical contact between the core and the carbon electrodes.

The electrodes consist of a number of square rods of carbon or graphite, which are held by heavy bronze holders F and G. Electrical contact with the carbon rods being rendered more perfect by means of a series of copper strips, indicated by black lines in Fig. 8, which are laid between the rows of carbon rods and are connected to the bronze holders or directly to the cables from the bus bars. The general construction of the furnace is similar to that of the graphite furnaces, the end walls and bottom of the furnace being permanent, while the side walls are loosely built, allowing the carbonaceous gases to escape and burn as shown in Fig. 40, and are taken down between the operations to allow of emptying and refilling the furnace. The electrical equipment is similar to that of the graphite furnaces, but there are more electrical units provided, as 3, 750 K.W. furnaces and 1, 1,000 K.W. furnace can be operated at once.

The Carborundum furnace has been described by F. A. J. FitzGerald* who gives a scale drawing of a 750 K.W. furnace. The furnace was $16\frac{1}{2}$ feet long, 6 feet wide, and $5\frac{1}{2}$ feet high inside, and has a core of coke, 16 feet long and 20 inches in diameter. In the patent just referred to a furnace of 1,000 K.W. was stated to have a core 8 feet long and 10 inches in diameter, composed of grains $\frac{3}{16}$ of an inch in diameter, of coked bituminous coal.

At the end of the operation the carborundum is found in a cylindrical crystallized mass surrounding the core, and around the carborundum is a layer of uncrystallized carbide which has been called carborundum fire-sand. In the furnace figured by FitzGerald the carborundum cylinder is 50 inches in diameter. The layer of fire-sand is often 1 inch or $1\frac{1}{2}$ inches in thickness. The grains of coke composing the core have become partly graphitized. They can be used again, and their use will be better in general than that of fresh coke as the resistance of the core will be less variable when they are used. The temperature of the furnace is highest in the middle, that is just around the core, and the inner part of the carborundum may be heated above its dissociation temperature and be converted into graphite, the silicon being volatilized and driven into the cooler parts of the furnace. The accidental formation of graphite in this way led to its regular manufacture in the Acheson furnace. The temperature of the carborundum furnace has never been measured and has been supposed to be as high as $3,000^{\circ}\text{C}$. Measurements by Messrs.

*The Carborundum Furnace, F. A. J. FitzGerald, *Electrochemical Industry*, vol. iv., p. 53.

Tucker and Lampen put the dissociation temperature of carborundum, and therefore the hottest part of the furnace as $2,220^{\circ}\text{C}$.

The consumption of energy per pound of carborundum was given by J. W. Richards as 3.8 K.W. hours. The output in 1905 was 5,596,000 lbs. Its main use is as an abrasive, being used instead of emery, it is made into wheels, sticks, hones, etc., the masses of carborundum being crushed, washed and graded into powders of varying degrees of fineness. These powders are usually cemented together to form the carborundum articles by moulding with kaolin and feldspar and firing in a kiln, but a method has been devised* for making solid blocks of carborundum by cementing the grains together with thin glue, and then heating in the electric furnace to the temperature of the formation of carborundum. The grains become firmly cemented together. The uses of carborundum and carborundum fire-sand as refractory materials have been referred to in Chapter IV. The Carborundum Company are now erecting a plant at Duesseldorf in Germany for the manufacture of carborundum for the European market.†

Siloxicon. This term covers a series of compounds of silicon, carbon and oxygen, having the general formula $\text{Si}_x\text{C}_x\text{O}$, which are produced in the electric furnace by heating a mixture of carbon and silica, in which there is not enough carbon to form carbide of silicon with the whole of the silica. This material was patented by Mr. Acheson in 1902.‡ The proportions indicated in the patent are one part of powdered carbon to two parts of powdered silica. The mixture must not be heated to the temperature of the formation of carborundum, because at that temperature siloxicon dissociates into carborundum, silicon and carbon monoxide. On account of the danger of overheating, it is desirable to employ a furnace with a number of cores, moderately heated; this arrangement enabling a large volume of the charge to be heated to a nearly uniform temperature, and thus giving a better yield of the siloxicon. Such a furnace is shown diagrammatically in Fig. 41, the core consisting of a large number of rods of graphitized carbon connected together by being fitted into blocks of graphite. In the furnace shown the rods are arranged partly in series and partly in parallel, $\frac{1}{3}$ of the entire current passing through each rod. The graphite blocks are shown supported on

*F. A. J. FitzGerald, U.S. patent 650,234, *Electrochemical Industry*, vol. v., p. 70.

†*Electrochemical Industry*, vol. iv., p. 348.

‡*Refractory Material*, E. G. Acheson, U.S. patent 722,793. *Electrochemical Industry*, vol. i., p. 287.

a layer of some refractory material on the bottom of the furnace. Siloxicon, the most usual formula for which is $\text{Si}_2\text{C}_2\text{O}$, is a loose powdery gray-green amorphous material, and can readily be removed from the furnace after taking down the side walls, by raking it out from between the cores. Such a furnace might be employed for the manufacture of amorphous silicon carbide, but could not be used for the production of the crystallized carborundum, as the system of cores would be destroyed after each opera-

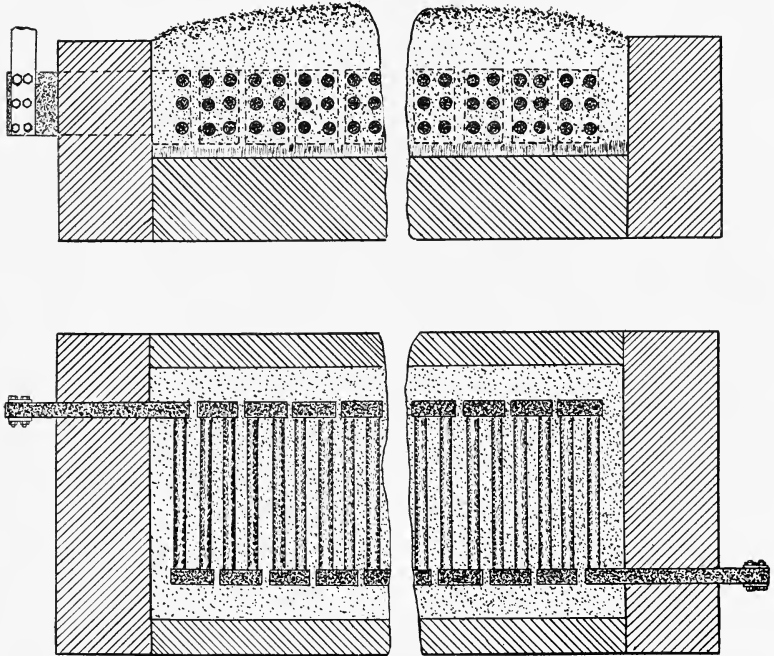
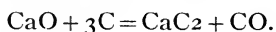

Fig. 41.—Multiple Core Furnace.

tion. Siloxicon forms a valuable refractory material, and its properties and uses have been described in Chapter IV.

Calcium Carbide. This carbide is universally known on account of the ease with which it reacts with water, liberating the valuable illuminant acetylene. The possibilities suggested by the discovery of this portable gas-producing substance naturally led to a very rapid development of its manufacture. Very many different forms of electric furnaces have been devised for its production, and whole books have been devoted to a description of its manufacture and uses.

The carbide is produced by heating lime and coke or anthracite in an electric furnace to a temperature which has been stated by Moissan to be $3,000^{\circ}\text{C}$. The lime and carbon react forming the carbide which is fluid at this temperature, and may be tapped from the furnace or allowed to solidify into a block and broken up when cool. The following reaction takes place:—



When the carbide comes in contact with water, acetylene is formed as follows:—

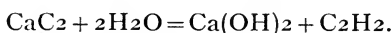

Calcium carbide has usually been made in arc furnaces, such as the Willson furnace, Fig. 7, p. 10, but recently resistance furnaces have been employed,* furnaces of 500 horse-power and 1,200 horse-power having been installed in French plants. The voltage of these resistance furnaces is only about 30 or 40 volts instead of 60 which was the usual figure with arc furnaces.

The inventor, T. L. Willson, in his patents gives 35% of coke and 65% of quicklime as the best proportions for the mixture, and states that 1 pound of the carbide will yield about $5\frac{1}{2}$ cubic feet of acetylene.

Digests of a number of calcium carbide patents will be found in volume v., of the Electrochemical Industry. A large number of electric furnaces for the production of calcium carbide are described and figured in V. B. Lewes' Acetylene, and Borchers' and other books on electric smelting.

III.—Electrothermic Production of Zinc.

Although zinc is one of the common metals, and has long been produced in furnaces fired by coal or gas, its volatility and the ease with which it becomes oxidized present serious difficulties in the treatment of its ores, and many attempts have been made to overcome these difficulties by smelting ores of zinc in the electric furnace.

In the usual process of zinc smelting, the ores are first roasted to remove the sulphur in the case of sulphide ores, or the carbonic acid in the case of carbonate ores, and the resulting oxide of zinc is mixed with about one-half its weight of coal and heated in re-torts or muffles made of fire-clay. In order to complete the reduction of the oxide to the metallic state it must be heated to a

*Electrochemical Industry, vol. iv., p. 27.

temperature above the boiling point of the zinc, which is consequently given off as vapor, passing in that form out of the retort, and is condensed to the liquid metal in a condenser, from which it can be removed and poured into moulds.

The residue is then removed from the retort and the operation repeated. The retorts are heated externally by coal or gas firing, and as the ore must be heated to about $1,200^{\circ}\text{C}$., or $2,200^{\circ}\text{F}$., the retorts cannot usually be made very large, and frequently only hold about 100 pounds of the ore mixture, from which it will be seen that the cost of labor in zinc smelting is likely to be high. The utilization of heat in these furnaces is also very poor on account of its slow transmission through the walls of the retorts, the heat efficiency of such a furnace being given by Prof. Richards* as under 7 per cent. At the high temperature of zinc distillation the retorts only last about a month, and their renewal forms a considerable item of expense. Other difficulties are met in the condensation of the zinc vapor, as this does not all collect in the liquid state, but in part as a powder, which cannot be melted together, while a part of the vapor escapes altogether.

Most of the difficulties that have been referred to are caused by the necessity of heating the ore in a number of small retorts, heated externally, instead of in a large furnace in which the heat could be produced in close contact with the ore. Attempts have been made to reduce the ore in some form of blast furnace, but the zinc was too easily oxidized by the furnace gases, and it was not possible to condense the zinc to the liquid state, as the vaporized metal was in a very diluted condition in the gases leaving the furnace. Zinc oxide suitable for making paint is, however, produced by means of small blast furnaces, and is filtered out of the gases by passing them through woolen bags.

In the electric furnace, heat can be produced without the necessity of blowing air into the charge; the atmosphere in the furnace can be made thoroughly reducing, so that no zinc will be oxidized, and the gases leaving the furnace are no more than leave the zinc retort in the usual process, so that the condensation of the zinc should be satisfactory. The production of heat electrically, in the midst of the ore mixture, enables the furnace to be made of any convenient size, and thus reduces greatly the expense of labor, while, as the heat has not to be transmitted through the furnace walls, these will be far more permanent and a great source of expense will thus be removed.

*J. W. Richards' Metallurgical Calculations, Part I., p. 80

Although the advantages that could be gained by smelting zinc ores electrically were very obvious, the practical application of electrical heating to this process has not been easy. The first electrical furnace for distilling zinc ores was patented by the Cowles brothers in 1885, and consisted, Fig. 42, of a fire-clay tube, A, closed at one end by a carbon plug, B, and at the other end by a carbon crucible, C, and lid, D. The charge of roasted ore and coal was contained in the tube, and electrical connections were made to the carbon plate and crucible so that an electric current flowed through and heated the ore in the tube. The tube was surrounded with some suitable material to reduce the loss of heat. The vaporized zinc and other gaseous products of the process escaped through a hole into the crucible, where the zinc condensed to a liquid at Z, while the remaining gases passed away by the pipe E. The furnace was practically an electrically heated zinc retort, and, as shown in the figure, the process was intended to be intermittent in action, one charge being exhausted and then

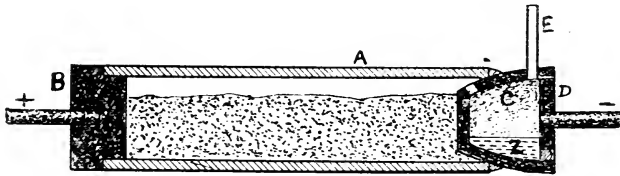

Fig. 42.—Cowles' Electric Zinc Furnace.

discharged before another could be introduced. Provision could, however, have been made for the continuous charging and discharging of such a furnace, but the process was never completed.

A furnace recently patented by W. McA. Johnson,* of the Lanyon Zinc Co., Fig. 43, is practically the same as the Cowles' furnace, but it is designed on a larger scale, and care has been taken to prevent the overheating of the walls of the furnace. It consists of an arched chamber, A, with end walls, B and C, and a flue, D, through which the zinc and other gaseous products of the operation can pass. The whole furnace is supported upon I beams, thus enabling the air to pass underneath and prevent overheating. The furnace is constructed of fire-clay bricks, but as additional protection, a layer, M, of refractory material, such as silica, high-grade fire-clay or bauxite, is placed on the hearth. The ore mixture consists of roasted ore mixed with enough coke to

*W. McA. Johnson, Electric Zinc Furnace, U.S. patent 814,050, filed May 24th, 1904, *Electrochemical Industry*, vol. iv., p. 152.

reduce the zinc and to carry the electric current. Some of the ore to be treated contains considerable amounts of iron, lime, lead and copper, and would be likely to flux the walls of the furnace. This low-grade ore is, therefore, placed in the middle and upper part of the furnace at K, being separated from the floor and walls by a layer of purer ore, J. All the ore is mixed with enough coke to reduce the zinc it contains, but in order to prevent the overheating of the walls care is taken that the mixture K shall be a better electrical conductor than the mixture J, so that the current will pass mainly through the middle of the furnace. E and F are heaps of coke serving as electrodes, the

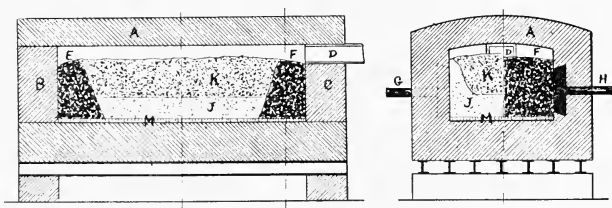

Fig. 43.—Johnson's Electric Zinc Furnace.

current flowing between E and F through the ore mixture. Electrical contact is made with the coke by means of graphite or carbon blocks and rods passing through the front and back of the furnace. G and H are connected to one cable bringing the current, and make contact with the coke F, while two similar terminals connect the other cable to the coke E. This furnace is the same in principle as an ordinary zinc retort, but the production of the necessary heat within the retort, which can only be effected electrically, enables the dimensions of the retort to be increased to any desirable extent, and the walls, instead of being thin, as was necessary when the heat had to pass through them, can be made of any suitable thickness. The furnace is necessarily intermittent in action, and would be allowed to cool somewhat to allow of the spent ore being removed through some convenient opening and a fresh charge being carefully arranged in the furnace before it could be again heated. The zinc vapors passing through the flue D would enter a system of condensing chambers, the first section of which would be kept at a temperature above the melting point of zinc in order to obtain that metal in the molten condition.

The electric zinc furnace of C. P. G. de Laval, Fig. 44, was patented some years ago, and has this advantage over the John-

son furnace, that the ore mixture can be continually charged into the furnace, and that the residues are fused and can be tapped out at intervals without interrupting the operation of the furnace. The heating is effected by an arc which is maintained between two carbon electrodes, one of which is shown at E. The ore mixture is introduced continuously by means of a charging shaft, A, or by a hopper and screw feed through the wall, F,* and forms a heap, C, in the furnace, where it is gradually heated, the zinc reduced to the metallic state and distilled, and the residues finally

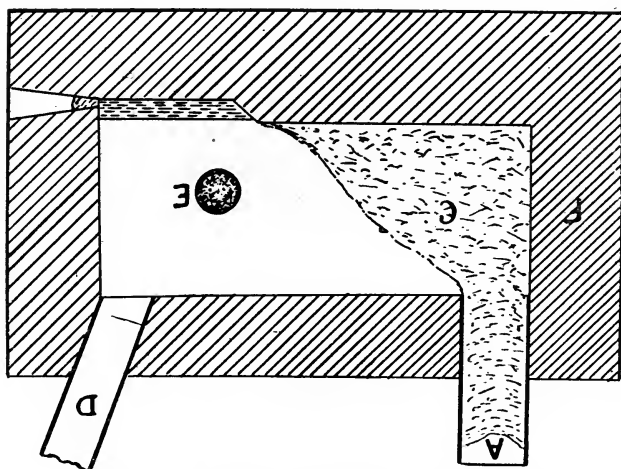

Fig. 44.—Laval's Electric Zinc Furnace.

melted by the heat of the arc. The vaporized zinc and the gases produced by the action of the coal on the ore, escape by a passage, D, to condensing chambers, where the zinc is obtained in the liquid state. The heaping up of the ore in the furnace serves to protect the charging aperture and the gradual heating of the ore is probably an important feature of the process, as it allows the zinc oxide to be reduced to the metallic state, and the resulting zinc to escape from the ore before fusion sets in, as it is difficult to liberate the metal from its ore when in a pasty or fused state. The utilization of the electrical heat in this furnace is not perfect, but the operation is simple, and, therefore, not likely to give trouble. Information with regard to the actual working of the furnace is not available, so that it is impossible

*C. G. P. De Laval, U.S. patent 768,054, *Electrochemical Industry*, vol. ii., p. 423.

to say exactly how much power is needed to reduce the zinc, how perfectly the zinc is extracted from the ores, or how completely the distilled zinc condenses to the liquid state. The process has been in operation commercially for several years in Europe, where three plants are now in operation. Three thousand horse-power is employed at Trollhattan (Sweden) in the reduction of ore and zinc ashes (galvanizers' waste), 4,000 horse-power at Sarpsborg

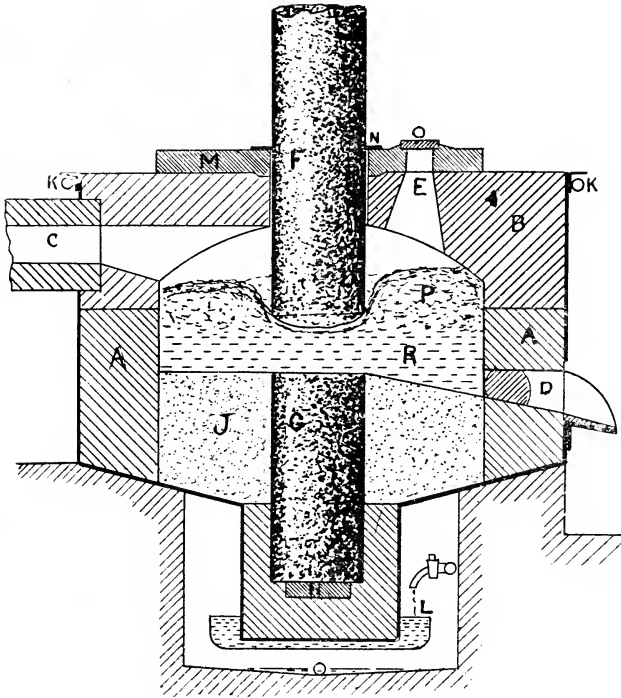

Fig. 45.—Salgues' Electric Zinc Furnace.

(Norway) in the reduction of zinc ashes, and 1,800 horse-power at Hallsthammar in the smelting of ore.*

M. A. Salgues† wrote an account of the electro-metallurgy of zinc, and figured two or three furnaces, one of which, intended for use with 100 kilowatts, is illustrated in Fig. 45. It consists of a chamber, built in two parts, A and B, to facilitate cleaning

*Report of the Commission to investigate the zinc resources of British Columbia and the conditions affecting their exploitation, Ottawa, 1906.

†Salgues, Bull. Soc. Ing. Civ., 1903, p. 174.

and repairing, an off-take, C, for the passage of the zinc and other gases, a tap-hole, D, and two charging and poking holes, one of which is shown at E. Heat is produced in the charge of ore by the passage of a current between the carbon electrodes, F and G, F being movable and supported by a suitable carbon holder, while G is set in the base of the furnace, and electrical contact is made with it by the bar of metal, H. The furnace is built of firebricks inside an iron jacket, which is cooled by sprinklers shown at K, the lower carbon holder having a special water-cooling device, shown at L. The hearth of the furnace is, however, lined with sand, J, as is common in many smelting furnaces.

Salgues draws special attention to the means by which he keeps the furnace air-tight around the upper carbon and at the poking and charging holes. For this purpose he provides a heavy cast iron plate, M, in which are holes for the electrode and for charging, the latter being closed by lids, O. The gases in the furnace, being under a slight pressure, rush out through any opening, such as the crack around the electrode, but a ring of asbestos, N, delays the gases a little, and the zinc vapor will then condense on the iron plate (which is cooled by a jet of water), and immediately closes the crack. In the same way, after charging or poking, the crack between the lid, O, and its seat is immediately sealed by the zinc, which condenses there.

The charge, consisting of roasted ore and the necessary carbon for its reduction, being introduced at E, from time to time, lies around the carbon, F, and as it becomes heated the zinc is reduced and volatilized, passing through C to condensing chambers; while the residue of the ore, which would need to be fusible, collects in the molten state at R, and is tapped out at intervals. This furnace is continuous in operation, and incidentally allows of the smelting of associated metals, such as lead, which will collect in the furnace and be tapped out with the slag. The heat may be produced in this furnace by the passage of the current through the molten slag, R, but if the electrode, F, were raised higher an arc would be produced. Salgues experimented at Champagne (Ariege), France, with a modified carbide furnace of 100 kilowatts, and using ores carrying 40 to 45 per cent. of zinc, fed cold into the furnace, he obtained a yield of 5 kg. of zinc (probably zinc dust) per kilowatt day.

A notable defect in the electric smelting of zinc ores is the difficulty experienced in attempting to obtain the distilled zinc in the liquid state. In the older processes a large proportion of the zinc condenses as a liquid in the clay condensers, which are

fitted to the end of each retort, and are hot enough to keep the metal liquid, a small portion passing on to the cooler "prolong" and condensing in this as a metallic powder; but the electric furnace makes very little liquid zinc, nearly all being in the state of powder. The explanation of this is probably that in the older process the ore was heated very gradually in the retort, and the reduction of oxide to metal was partly completed before the zinc began to distil from the retort. In this way the carbon monoxide, moisture and other products of the ore and the coal had been partly driven off before the distillation began, and the zinc vapors were in consequence more concentrated, and condensed more readily to the liquid state.

The conditions for the production of liquid or powdery zinc will be seen at once when it is remembered that the former corresponds to rain and the latter to hoar-frost or snow. A hot, moist wind being cooled to some temperature above the freezing point will form rain, while, if the air is so dry, that is, the water vapor is so dilute, that the air must be cooled below the freezing point before saturation occurs, hoar-frost or snow will result. Besides this general consideration there is the need of time, and points on which the precipitation may occur; the slow distillation in the older retorts would, therefore, be more favorable to the condensation of zinc than the rapid work of an electric furnace, with a rush of gas carrying the zinc vapor into the colder parts of the condenser before the metal has had time to condense into drops. Salgues describes an arrangement for condensing the zinc in the powdery form in a series of tubes, the zinc being protected from oxidation and re-distilled in an auxiliary furnace, in which, as the vapor is quite concentrated, liquid zinc can be obtained.

It is in the smelting of mixed ores containing both zinc and lead, usually associated with silver, that the greatest advantage of electrical smelting may be expected. Such ores are very difficult to treat by ordinary furnace methods, because, if smelted as a lead ore in the blast furnace, the zinc makes infusible slags and chokes up the furnace with deposits of fume, and none of the zinc is recovered. If treated as a zinc ore, the lead makes the ore fusible so that it corrodes the retorts, besides yielding an impure zinc containing some lead. When treated as a zinc ore, the lead and silver can be recovered by smelting the residues from the zinc retorts.

The Broken Hill ores are notable examples of a mixed sulphide of lead and zinc which cannot be separated at all com-

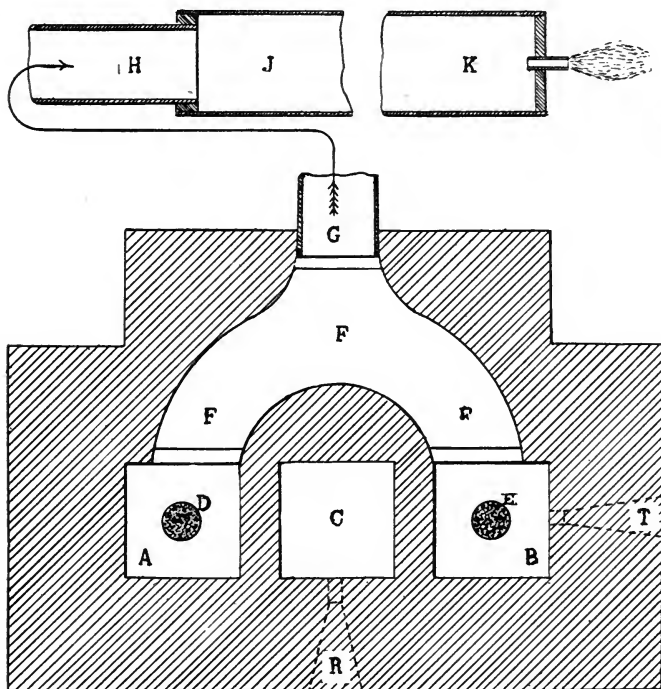
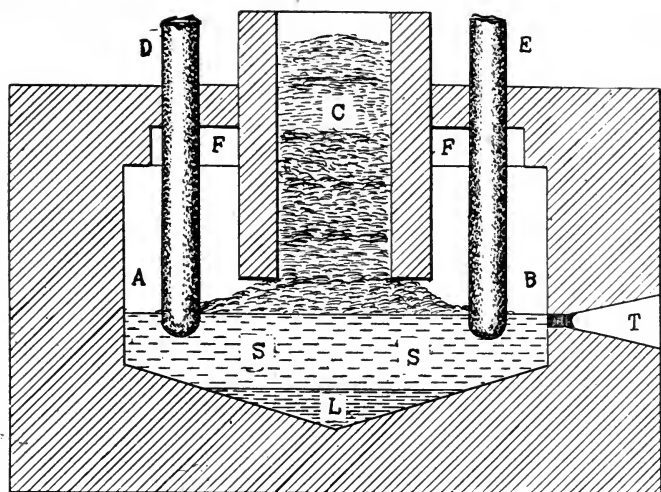

Fig. 46.—Experimental Zinc Furnace.

pletely by mechanical means and must be treated as a whole by smelting or chemical methods. It occurred to the writer several years ago that such ores could be smelted electrically so as to recover at one operation the zinc, lead and silver from the ore; the zinc being distilled and condensed, while the lead carrying the silver from the ore, would collect in the molten condition as in ordinary blast furnace practice. Numerous experiments on a laboratory scale showed that this could be accomplished, and that the extraction of the lead was particularly good, only traces of that metal remaining in the slag.

The furnace in which these experiments were made is shown in Fig. 46.* It consisted of a rectangular chamber, AB, in which the ore was smelted, a charging shaft, C, for introducing the ore, and chambers, F to K, for condensing and collecting the zinc. The electric current was introduced by means of the carbon electrodes, D and E, which dipped into the molten slag in the furnace. In starting, a quantity of slag was melted and poured into the furnace which had previously been heated. The electrodes were then introduced, and the current switched on. The mixture of roasted ore, carbon and fluxes was poured into the shaft, C, which was kept nearly full during the operation of the furnace. The furnace was essentially a resistance furnace, the heating being accomplished by the passage of the current through the molten slag, and the furnace was made long and narrow in order that the electrical resistance might not be too low. Occasionally, however, the electrodes would become too short to reach the slag, and an arc was then formed. The products of the operation were lead, which collected at L, and was tapped out by the spout, R, slag which is shown at S, and was tapped out by the spout, T, and zinc vapor and other gases which left the furnace by the openings FF. The condensing system consisted of the chamber, F, in which a small amount of molten zinc collected, and an extensive system of iron pipes, GH, and JK, in which the greater part of the zinc collected in the form of zinc powder. The gases escaping with the zinc vapor were mostly carbon monoxide which burned at the end of the condensing system.

The cost of smelting sulphide ores of zinc is materially increased by the necessity of a very complete roasting operation

*This furnace was devised by the author and Mr. L. B. Reynolds, who did most of the experimental work. They have obtained the following patents on the electrical smelting of lead-zinc ores:—Canadian 102,231, Australian 1,681, German 18,3470, Mexican, 4,710.

before the distillation of the zinc. Any sulphur left in the ore to be treated by the ordinary process holds, as a rule, about twice its weight of zinc in the residues, and it is, therefore, the practice to leave no more than about one per cent. of sulphur in the roasted ore. So complete a removal of sulphur involves a prolonged roasting at a very high temperature, thus largely increasing the cost as well as the loss by volatilization of the lead and silver in the ore. Some inventors have tried to avoid this by smelting the ore, unroasted, in the electric furnace, with the addition of some reagent for absorbing the sulphur; iron, iron ore, alkaline salts and lime being suitable for this purpose.

F. T. Snyder, of the American Zinc Extraction Co., has patented* a process for obtaining zinc from a sulphide ore of this metal without roasting. The ore is mixed with carbon and fluxes (iron and lime), and smelted upon a bath of molten slag in an electric furnace from which the air is excluded. The inventor claims that the carbon reacts with the sulphur of the ore and forms carbon bisulphide, which is volatilized, liberating the zinc. It is not stated whether the iron and lime used as fluxes played any part in absorbing the sulphur and liberating the zinc. Direct current is used, and some electrolytic effect takes place, as the zinc is liberated at one electrode and the carbon bisulphide at the other electrode. The two vapors can, therefore, be kept apart and the zinc vapor, being undiluted, should be easily condensed. Even if the two vapors could not be kept separate, the amount of carbon bisulphide formed would only be about half as much as the carbon monoxide that would have been formed if the ore had first been roasted, and, therefore, the zinc vapor would be more concentrated and likely to condense better.

In an experiment, ore containing 20 per cent. zinc, 20 per cent. iron, 5 per cent. lead, 35 per cent. sulphur, and 20 per cent. of silica and alumina was mixed with iron and lime (and carbon) and fed into an electric furnace provided with carbon electrodes, between which scrap lead had been placed for starting the furnace. A direct current of 1,500 to 1,800 amperes at 7 to 15 volts was employed, heating the furnace to about 1,200°C. The ore melted and was reduced, zinc being liberated in the form of vapor near one electrode, while carbon bisulphide was formed near the other electrode. It is claimed that at least 94 per cent. of the zinc in the charge can be recovered by this process.

*F. T. Snyder, U.S. patent 814,810, filed June 23rd, 1905, Electrochemical Industry, vol. iv., p. 152.

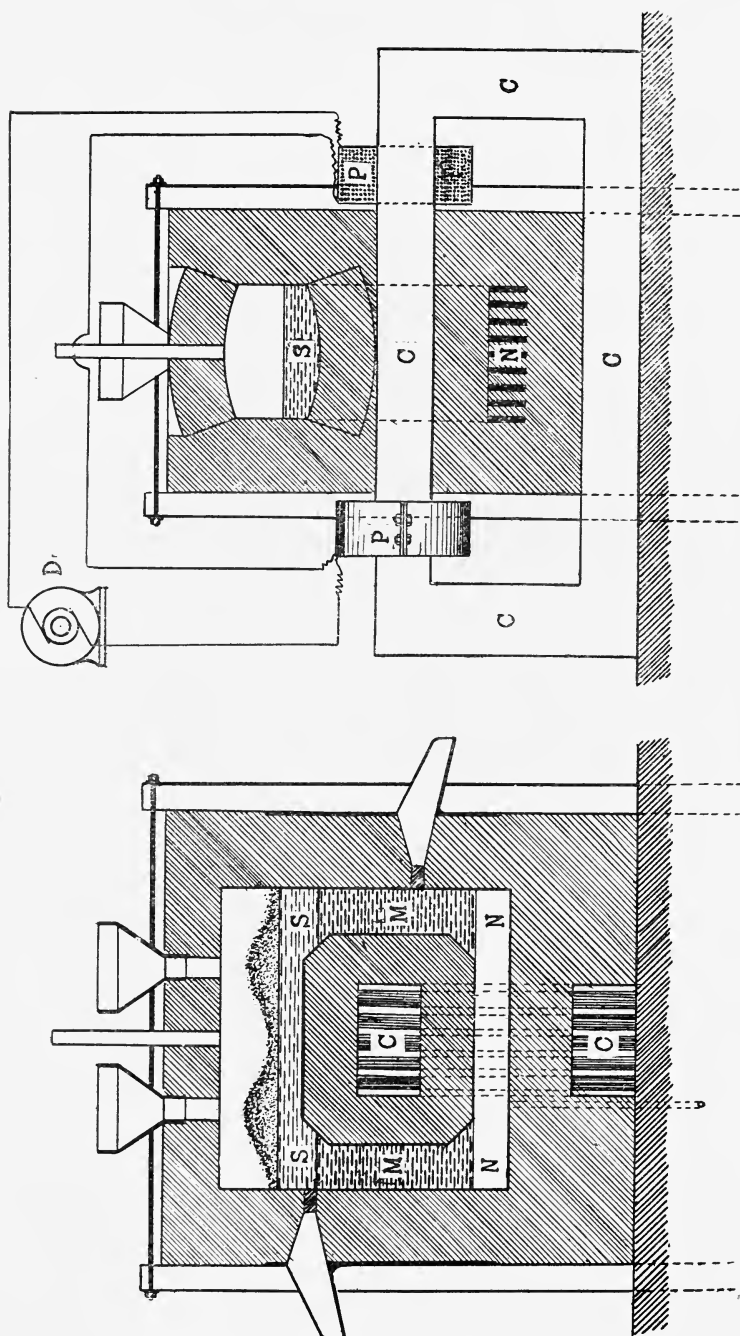

Fig. 47.—Snyder's Induction Furnace.

Mr. Snyder has experimented with induction furnaces for smelting zinc and other ores. The furnace represented in Fig. 47* being intended for ores in general, while a zinc-smelting furnace† would be provided with chambers for condensing the zinc. The furnace shown in Fig. 47, which could be used for smelting lead ores, has a laminated iron core, CC, a pair of primary coils, PP, and a secondary circuit made up of the molten slag, S, the molten metal, MM, and bars, N, of copper or some other metal which should not be attacked by the molten metal, M. The alternating current in PP, supplied by the dynamo, D, causes a much larger low-voltage current to flow around the secondary circuit, N M S M N, composed of the copper bars, N, the molten metal, M, and the molten slag, S. As the slag has a higher electrical resistance than the other parts of this circuit, the greater part of the heat will be developed in it, and the ore introduced through the hoppers will be heated, reduced and melted by contact with the super-heated slag. The iron core, CC, passes through the middle of the furnace, and is therefore provided with water-cooling devices, not shown in the drawing, to avoid overheating.

Mr. Snyder's latest zinc furnace‡ is shown in Fig. 48. It is designed for the treatment of lead-zinc ores, with the special intention of obtaining the resulting zinc in a coherent liquid state, instead of in the form of a powder. The furnace is constructed on the lines of a lead blast-furnace, having a water-jacketed smelting shaft, bb, and a crucible aa, holding the molten lead and molten slag produced in the operation. A siphon tap, O, enables the molten lead to flow out of the furnace, and the slag and matte formed are tapped out through the hole, l. The special feature for obtaining liquid zinc is the provision of the water-jackets, bb, and of channels, gg, at the bottom of the water-jackets. The charge contains partly roasted ore, carbon and fluxes, and as it descends in the furnace, the zinc and other metals are reduced to the metallic state, and gases such as carbon monoxide are liberated. A part of these gases is liberated in the upper and cooler part of the shaft, so that the zinc vapor, which is not formed until the ore reaches the hotter part near the bottom

*Induction furnace, F. T. Snyder, U.S. patent 825,359. Application filed July 15th, 1904. See *Electrochemical Industry*, vol. iv., p. 319.

†Induction Furnace for Zinc, F. T. Snyder, U.S. patent 859,134. See *Electrochemical Industry*, vol. v., p. 323.

‡Drawing and description sent to the author by Mr. Snyder. Compare F. T. Snyder U.S. patent 859,133. See *Electrochemical Industry*, vol. v., p. 323.

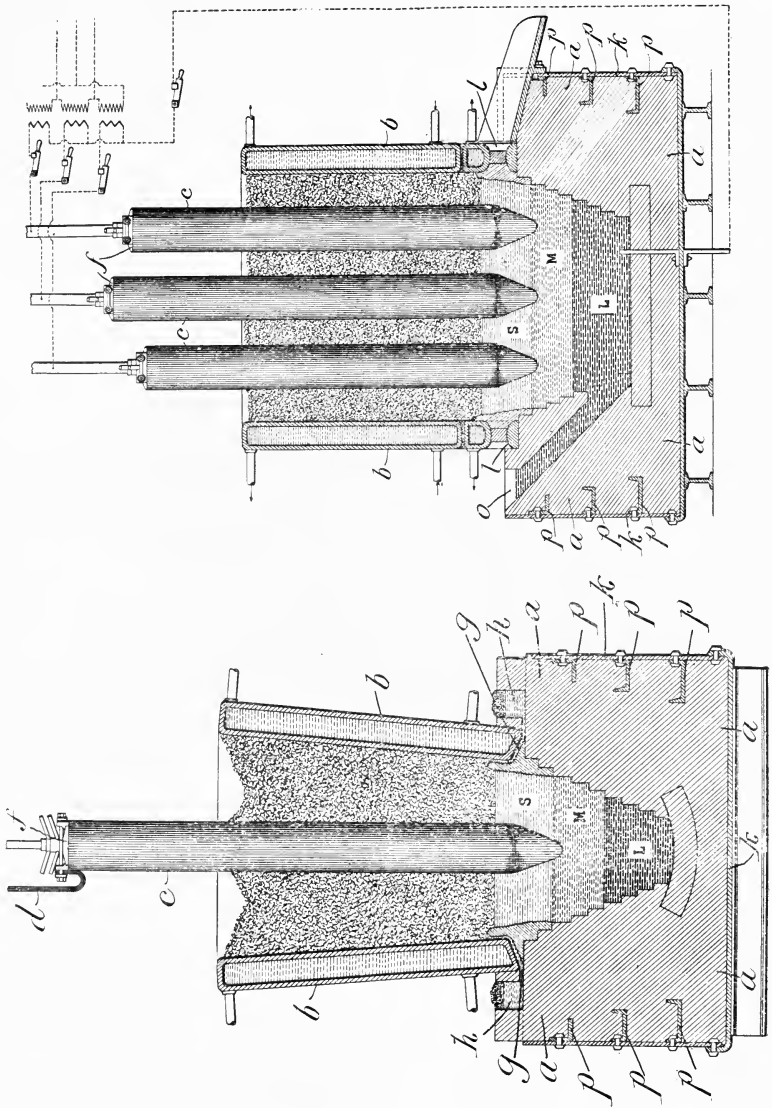

Fig. 48.—Snyder's Furnace for Obtaining Liquid Zinc.

of the shaft, is less diluted by permanent gases than it would be if the zinc and the gases were all liberated in a common chamber as would be the case in Fig. 47. The zinc vapor passes up the shaft, with the other gases, but on reaching the cooler parts of the ore, it is largely condensed in the ore, and passes down again with the descending ore to the hotter parts of the furnace. The result of this process is that the zinc vapor becomes concentrated in the lower part of the furnace, and finally begins to condense in the liquid state in the vicinity of the water-cooled walls, bb. The condensation of the zinc vapor occurs more freely at the sides of the furnace than at the ends, since the former are further from the carbon electrodes, and are therefore cooler. The condensed zinc flows out of the furnace through the channels, gg, beneath the sides of the furnace, and collects at hh. The molten materials in the bottom of the furnace are lead, L, matte, M, and slag, S. The slag becomes congealed around the sides and ends of the furnace, and in this way maintains the channel through which the zinc flows. This is possible because zinc melts at 419°C . whilst the slag will remain solid up to at least $1,000^{\circ}\text{C}$. The solidified slag also serves to prevent any leakage of the current by passing through the molten slag into the metal of the water-jacket. Such leakage could take place, however, higher up in the furnace where there is no slag to form a crust on the iron.

Another feature of interest is the arrangement for using three-phase current. The inventor has adopted the system explained in chapter v., Fig. 35, in which three electrodes, or some multiple of this, are employed and are connected to the transformers in such a way that the current entering by any electrode returns through the other two, thus rendering unnecessary the three return cables shown in Fig. 33 and Fig. 34. A single return cable from the molten lead in the furnace is provided to carry any unbalanced current. This arrangement avoids the difficulty that would arise from the inductive effect of the iron jackets if the current passed completely through them, entering the furnace by the electrodes, cc, and leaving by a connection from the crucible, aa, as in the Heroult furnace, Fig. 29.

In smelting a sulphide ore of lead and zinc in this furnace, it is first roasted until it contains about 8% of sulphur and then smelted in admixture with coke or charcoal and fluxes. The charge is proportioned so that the resulting slag will be high in lime and silica, (at least 50% of the latter), as such a slag will not retain any considerable quantity of zinc, on account of its

high melting temperature, and will have a high electrical resistance. A considerable amount of matte is preferred, enough iron being present in the charge to prevent much of the zinc-entering the matte.

This furnace has been described at length, as being the first electrical zinc furnace in which any rational attempt has been made to obtain the zinc in the liquid state. The author would anticipate certain difficulties in the operation of such a furnace, such as the formation of crusts of zinc in the shaft, which would prevent the regular descent of the charge and the passage of the furnace gases.

With regard to the amount of electrical energy required to smelt a ton of roasted zinc ore the following data may be given. Salgues states that from a 40 or 45 per cent. ore he extracted 5 kg. of zinc per kilowatt day. This would correspond to 1,660 kilowatt hours per 2,000 pounds of zinc ore if the zinc obtained amounted to 38 per cent. of the ore. Casaretti and Bertani* produced at Bergamo, Italy, 9 kg. of zinc per kilowatt day, which, on a zinc extraction of 38 per cent. of the ore, would mean 920 kilowatt hours per 2,000 pounds of ore. The author, using a mixed lead zinc ore carrying about 25 per cent. of each metal, was able to extract both metals with an expenditure of from 800 to 850 kilowatt hours per 2,000 pounds of ore, using the ore cold, and in a small furnace of only 15 kilowatts. Snyder† has made a calculation based partly on the fuel needed in blast furnace lead smelting and partly on the heat theoretically needed to reduce and distil zinc from its ores, and gives the formula, $623 + 5.4$ times the percentage of zinc, for the kilowatt hours needed per 2,000 pounds of a lead zinc ore. From the above data it may be fairly inferred that smelting mixed lead zinc ores in large electrical furnaces would take less than 800 kilowatt hours, while for ores running higher in zinc, say 40 to 50 per cent., about 900 kilowatt hours would be needed. These figures correspond to the treatment of the cold ore which had previously been roasted to remove the sulphur; if the ore could be charged hot from the roasting furnace, or if the carbon monoxide resulting from the smelting operation could be used to pre-heat the ore, a decidedly lower figure should be sufficient.

*Casaretti and Bertani, Report of Commission on zinc resources of British Columbia, 1906, p. 131.

†Snyder, Journ. Can. Min. Inst., vol. viii., 1905, p. 130.

IV.—Miscellaneous Uses of the Electric Furnace.

Silicon.—It has been estimated by Dr. F. W. Clarke* that silicon forms 27.4% of the contents of the solid crust of the earth. It exists in combination with oxygen, as silica which constitutes, according to this estimate, 58.3% of the earth's crust. Although so widely distributed, silicon has so strong an affinity for oxygen that until recently it could only be obtained in small amounts.

Alloyed with certain metals, silicon has long been of metallurgical importance. Ferro-silicon, already referred to, has been employed in the manufacture of steel as a deoxidizer and to prevent the formation of blow-holes in steel ingots. Cast iron contains a small amount of silicon, which has a very great effect on the properties of the iron.

Silicon has been obtained in the electric furnace by the action of carbon on silica, but it is not easy to obtain silicon in this manner because it is volatile at the temperature of the reaction. Mr. F. J. Tone has overcome this difficulty and has produced considerable quantities of silicon using at first the furnace shown in Fig. 15, p. 25. More recently he has employed a furnace like the Heroult steel furnace for the production of silicon and its alloys.† The production of silicon in the electric furnace has been described by F. J. Tone,‡ who also gives an account of its properties and uses. Silicon produced in the electric furnace is a brittle crystalline body with a dark silver luster. Its specific gravity is 2.34 and it melts at 1,430°C. It is not pure, however, but contains about 1% of iron, 1½% of aluminium, and 2% of carbon.

The heat of oxidation of silicon has been determined by Dr. H. N. Potter,§ who gives 215,692 calories as the heat formation of one gram molecule of silica. Using this figure it can be shown that the oxidation of silicon affords more heat per unit weight of oxygen than the oxidation of any of the metals except aluminium and the alkaline earth metals such as magnesium and

*Dr. F. W. Clarke, of the United States Geological Survey. Quoted in *Electrochemical Industry*, vol. iii., p. 409.

†Production of Silicides and Silicon Alloys. F. J. Tone, U.S. patent 842,273; see *Electrochemical Industry*, vol. v., p. 141.

‡Production of Silicon in the Electric Furnace. F. J. Tone, *Trans. Amer. Electrochem. Soc.*, vol. vii., 1905, p. 243.

§H. N. Potter, *Trans. Amer. Electrochem. Soc.*, vol. xi., abstracted in *Electrochemical Industry*, vol. v., p. 229.

calcium. The great affinity of silicon for oxygen has enabled it to be used for the reduction of metals such as chromium and tungsten in the electric furnace.* Dr. Goldschmidt has stated that silicon cannot be used instead of aluminium in the thermit mixtures for welding and the production of carbon-free metals, as the reaction between silicon and iron oxides is not sufficiently rapid. It is claimed, however, that Mr. Albro has succeeded in using silicon in this manner;† the mixture of silicon and oxygen-supplying compound which he uses being called Calorite.

Silicon-copper, an alloy of silicon, is used as a deoxidizer in making castings of copper and copper alloys, in the same way that the ferro-alloy of silicon is used in making steel castings. Copper-silicon is made in the electric furnace by the Cowles Electric Smelting and Aluminium Company, at Lockport, N. Y.‡

Fused Quartz.—Silica, the oxide of silicon, is a valuable refractory material for lining metallurgical furnaces. Its uses as a refractory material have been described in Chapter IV. Although very refractory, silica or quartz can be fused, and it then possesses valuable properties, and has been used for some time in the construction of scientific apparatus. As an example, the well-known quartz filaments of C. V. Boys may be mentioned. These are made by melting the quartz in the oxyhydrogen blow-pipe. Recently it has been found possible to fuse quartz in the electric furnace and to make tubes, crucibles, dishes and other articles out of the fused quartz. This material scarcely expands at all when heated, its coefficient of expansion being only one-twentieth of that of glass. In consequence of this it is possible to plunge a red-hot article made of fused quartz into cold water without cracking it. Fused quartz is a transparent glass, but "Electroquartz" or silica melted in the electric furnace has a milky white color. Articles of this material can be obtained from the Wilson-Maeulen Co., 110 Liberty Street, New York.§

Information with regard to the manufacture of fused quartz articles in the electric furnace can be found in the *Electrochemical Industry*, vol. iii., p. 53, and vol. iv., pp. 369 and 502.

Glass.—Although glass can easily be melted in furnaces fired by gas, the cleanliness and convenience of electrical heating have

*F. M. Becket, patents described in *Electrochemical Industry*, vol. v., p. 237.

†*Trans. Amer. Electrochem. Soc.*, vol. vii., p. 249.

‡Silicon-copper in the Brass Foundry, *Electrochemical Industry*, vol. ii., p. 121. ¶

§*Electrochemical Industry*, vol. v., pp. 67 and 107.

led to the use of the electric furnace in the manufacture of glass. A large number of furnaces have been devised for this purpose and particulars of some of these will be found in Wright's book on Electric Furnaces, and in volumes i., ii., and iii., of the Electrochemical Industry.

Alundum.—This is an artificial corundum or emery made by fusing bauxite in an electric furnace, and allowing it to cool slowly, thus forming a hard and tough crystalline mass which is broken up and used as an abrasive. The process was invented by C. B. Jacobs,* and the material is manufactured at Niagara Falls by the Norton Company.† An electric furnace suitable for the manufacture of alundum has been patented by A. C. Higgins.‡

Nitric Acid.—An interesting application of the electric furnace is found in the production of nitric acid from air. It has been known for a long time that an electric discharge has the property of causing the oxygen and nitrogen of the air to combine together, forming nitric oxide, and the method was used a number of years ago for removing nitrogen from air and so isolating the small amount of argon which it contained. Many inventors have tried to find a method of producing nitric acid or other compounds of nitrogen from the air on a commercial scale, and by one process, that of Birkeland and Eyde,§ calcium nitrate is now produced on a considerable scale. The apparatus consists of a disc-shaped furnace, lined with fire-brick, in which an electric arc is maintained between two water-cooled copper electrodes which are held about one centimeter apart. An alternating current, at about 5,000 volts, is employed to produce the arc, which is spread out, by means of a strong electro-magnet, into a disc of flame as much as $6\frac{1}{2}$ feet in diameter. This immense arc consumes no less than 500 kilowatts, and even larger furnaces are contemplated. Air is passed through the furnace, traversing the arc, and a portion of the nitrogen combines with oxygen to form nitric oxide, of which about 2% is present in the issuing air. After leaving the furnace the gases pass through

*C. B. Jacobs, U.S. patent 659,926, *Electrochemical Industry*, vol. iii., p. 406.

†*Electrochemical Industry*, vol. i., p. 15.

‡A. C. Higgins, U.S. patent 775,654, *Electrochemical Industry*, vol. iii., p. 30.

§The manufacture of Nitrates from Air, by A. J. Lotka, *Chem. Ind.*, 1905, p. 695, abstracted in *Engineering and Mining Journal*, 1907, p. 848.

Electrical Extraction of Nitrogen from the Air, by J. S. Edstrom, *Trans. Internat. Electrical Congress, St. Louis, 1904*, vol. ii., p. 17, abstracted *Electrochemical Industry*, vol. ii., p. 392.

Electrochemical Industry, vol. iv., pp. 126, 295, and 360; vol. v., p. 358.

reaction towers in which the nitric oxide combines with more oxygen to form nitric peroxide and this unites with water to form nitric acid. The acid is not sold in that form but is neutralized with limestone yielding calcium nitrate which is found to be an excellent fertilizer as well as forming a raw material for certain chemical processes. The yield of this material corresponds to 500 or 600 kilograms of pure nitric acid per kilowatt-year. The industry is carried on at Notodden in Norway, where the operating company controls water falls with an aggregate of 350,000 horse-power which can furnish electrical energy at a cost of about \$3 per horse-power-year.

Phosphorus.—This is largely made in the electric furnace. It is obtained by heating a phosphate with carbon and sand. The phosphorus is reduced and volatilized while the remainder of the charge melts to a slag. As the charge must be heated in the absence of air, the electric furnace is particularly suitable for its treatment. Both arc and resistance methods of heating are employed.

Carbon Bisulphide.—This is another electric furnace product, and is made by heating carbon and sulphur. The electric current passes through a mass of broken carbon, which becomes strongly heated. The sulphur, melted by the waste heat of the furnace, flows down into the hot portion of the furnace, where it reacts with the carbon, forming carbon bisulphide, which passes off as a gas, and is condensed outside the furnace. The production of phosphorus and carbon bisulphide in the electric furnace is described in Wright's "Electric Furnaces and their Industrial Application," and in the volumes of the Electrochemical Industry.

V.—Electrolytic Processes.

Electrolysis.—The use of a "direct" current for dividing a chemical compound into two component parts has already been mentioned, see "Electrolytic Furnaces," p. 30, but a few words may be added here. When a direct or continuous current flows through a fused salt, or a solution of a salt in water, the salt, or the water, is broken up by the current into two parts. One of these parts is hydrogen, or a metal, which is liberated at the cathode or electrode through which the current leaves the liquid, while the remainder of the salt, or of the water, is liberated at the anode or electrode by which the current enters the liquid. Thus:—

2NaCl (electrolysed) = 2Na (at cathode) + Cl_2 (at anode). That is to say, when fused common salt is electrolysed, sodium is set free at the cathode and chlorine at the anode.

CuSO_4 (electrolysed in aqueous solution) = Cu (at cathode) + SO_4 (at anode). That is to say, the electrolysis of a solution of copper sulphate in water liberates copper at the cathode while SO_4 is set free at the anode. The final result of the operation will depend, however, upon the nature of the anode. If this is of platinum, or carbon, and is not attacked by the SO_4 , the latter will react with the water of the solution and will form sulphuric acid and oxygen, thus:—

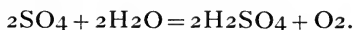

and the end products of the electrolysis will be copper at the cathode and oxygen at the anode. If, however, the anode were made of copper or some other metal that would be acted on by the SO_4 , this reaction would take place:—

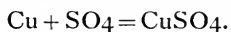

The copper sulphate solution would thus be regenerated, no oxygen would be liberated, and the only result of the operation would be a transfer of copper from the anode to the cathode.

The latter case is exemplified in the electrolytic refining of copper, the anode consisting of impure copper, which constantly dissolves under the action of the current, while pure copper is deposited on the cathode. When it is desired to extract a metal from the fused salt or solution in which it is contained, the anode should, if possible, be insoluble in whatever is set free at its surface; or, if this is impossible, it should be inexpensive, as it will be dissolved in proportion as the other metal is recovered.

In the equation given above for the electrolysis of fused common salt, chlorine and sodium are the end products. An aqueous solution could not be used for the production of sodium, as the water would react with the sodium, forming caustic soda and hydrogen.

In the electrolysis of a fused mixture of two salts or of a solution of a salt in water, the current breaks up the compound which is the least stable; thus in a solution of copper sulphate in water, the current separates the copper sulphate into its components, and not the water; but in a solution of aluminium sulphate, the water and not the aluminium salt is decomposed. It is necessary, therefore, to employ a solvent that is more stable than the salt it is desired to decompose, or, failing this, to use the pure salt in a state of fusion. This is why the extraction of aluminium from its ore is carried out in a fused mixture of fluorides instead of in an aqueous solution.

In the electrolysis of solutions a definite amount of electricity in passing through the solution will always produce a definite amount of decomposition. This amount is always the same for the same solution, and in different solutions chemically equivalent amounts of decomposition are effected. A current of one ampere flowing through acidulated water for one second will liberate 0.0104 milligrams of hydrogen, and in any other solution the weight of the metal liberated will be 0.0104 milligrams, multiplied by the atomic weight of the metal and divided by the valency of the metal in the particular solution. Thus, the amount of the monovalent metal sodium that would be set free per second would be $0.0104 \text{ mg.} \times 23$, the atomic weight of sodium, or 0.239 mg.; while the weight of copper deposited would be $0.0104 \text{ mg.} \times 63.2$, the atomic weight of copper, or 0.657 mg. in cuprous salts, such as Cu_2Cl_2 , in which copper is monovalent, while in the more usual cupric salts, such as CuSO_4 , in which the metal is divalent, only half that amount would be deposited by the current. The amount of metal actually obtained as the result of electrolysis is frequently less than the calculated weight on account of secondary reactions, such as the metal redissolving in the electrolyte, hydrogen being liberated instead of the metal, leakage of the current, etc., and the ratio of the metal actually deposited to the theoretical quantity is known as the current efficiency, as it shows what proportion of the current is effective in liberating the metal.

The electrical energy necessary to produce a definite weight of a metal, by the electrolysis of a chemical compound of the metal, depends not only on the number of ampere hours needed to liberate the weight of metal, but also on the voltage of the operation; that is on the electrical pressure needed to drive the electric current through the electrolyte so as to produce the decomposition. Each solution has a definite electrical pressure which must be exceeded before electrolysis will take place, and the working voltage must be decidedly above the minimum in order to drive a rapid current of electricity through the solution. The passage of the current also produces heat, the amount being proportional to the square of the current and to the resistance of the electrolytic cell, while, as has been noted, the amount of metal deposited is proportional to the current alone. For a given amount of chemical work accomplished, the heat generated will be less if the current is small, than if a large current is employed, and therefore the efficiency of the operation will be greater with

the smaller current. In electrolysis at furnace temperatures, however, it is often convenient to heat the electrolyte electrically instead of by the external application of fuel heat, and in such cases the production of heat by the current cannot be regarded as waste.

The nature of the anode has a great effect upon the voltage needed for electrolysis. Thus, electrolysing a solution of copper sulphate with an anode that does not dissolve, copper and oxygen would be liberated, the electric current would have to do the work of separating these elements, and a pressure of more than one volt would be needed; but if the anode were made of copper, this would dissolve as fast as the copper deposited on the cathode, no chemical work would be done, and the smallest voltage would suffice to produce electrolysis. It is possible to calculate, from available data, the amount of energy needed to separate a definite weight of a compound into its elements, and the relation of this to the electrical energy actually required to produce this decomposition is the energy efficiency of the process.

When an anhydrous salt or mixture of salts is used as an electrolyte it must be heated, usually to a red heat, to render it fluid, and its electrolysis may be classed as a furnace operation. Some examples of these electrolytic furnace processes will now be given.

The Acker Process for Caustic Soda and Chlorine.—In this process fused common salt or sodium chloride is electrolysed, using carbon anodes by which the current enters the liquid, and molten lead for the cathode by which the current leaves. The salt is broken up into chlorine, which is liberated at the anode and is led away and used for making bleaching powder, and sodium, which is liberated at the cathode and alloys with the lead. The lead containing the sodium is then treated with steam, which combines with the sodium to form caustic soda.

The following reactions take place:—

2NaCl (electrolysed) = Cl_2 (liberated at the anode) + 2Na
(alloying with the lead cathode).

2Na (alloyed with the lead) + $2\text{H}_2\text{O}$ (the jet of steam) =
 $2\text{NaOH} + \text{H}_2$.

The ingenious arrangement by which this is accomplished is illustrated in Fig. 49. The apparatus consists of an irregular shaped cast iron vessel, about 5 feet long, which is divided into three compartments, A, B, and C, with the connecting channel, R. The larger compartment, A, contains melted salt, S, resting

on a thin layer of molten lead which is caused to circulate as shown by the arrows. Four electrodes, E, of graphitized carbon are immersed in the fused salt and form the anode of the electrolytic cell, being connected to the positive cable from a dynamo. The iron tank is connected at the point H to the negative cable, thus making the molten lead, the cathode. The electric current passes from the carbon electrodes through the melted salt to the fused lead on which the salt rests. In passing through the salt, chlorine is liberated at the carbon electrodes and escapes, being drawn away by a fan, while the sodium is liberated at the surface of the lead and alloys with it. In the small compartment, B, a jet of steam introduced by the pipe, F, serves to blow the lead up the vertical pipe, P, and over into the third compartment, C, from which the lead returns by the passage, R, to the first compartment. The lead entering B is charged with sodium, and when it meets the steam in the pipe, P, the sodium

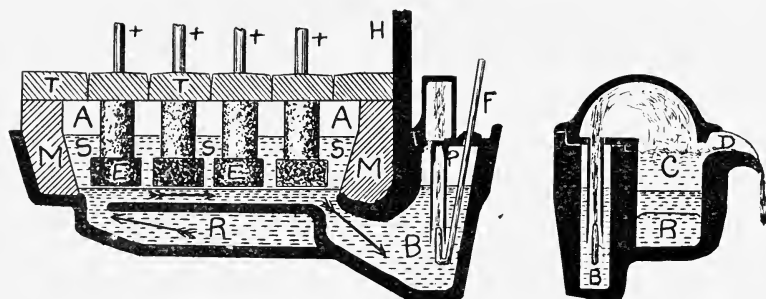

Fig. 49.—Acker's Caustic Soda Furnace.

combines with the steam, forming anhydrous caustic soda, which floats on the lead in C and overflows by the spout, D, and hydrogen, which escapes at D and burns. The compartment A is lined, above the level of the lead, with magnesite bricks, M, and the cover is formed of fire-brick tiles, T. The salt to be used in the process is warmed on the top of the furnace and then introduced through charging holes in the roof. Each anode consists of a block of graphitized carbon 14 inches long, $7\frac{1}{2}$ inches wide, and 3 inches thick, which is supported by two five-inch carbon rods passing through the top of the furnace. The carbon blocks are lowered until within $\frac{3}{4}$ -inch of the molten lead. The current used is 8,200 amperes, the voltage of each furnace or pot being only 6 or 7. From 40 to 45 pots are used at once, being connected in series, so that the same current passes through them all, and the total voltage necessary is 275; about

3,000 horse-power being supplied at the generating station, which is 1,500 feet away. The current density at the anodes is about 2,750 amperes per square foot, and this is sufficient to keep the salt at a temperature of 850°C., which is a bright red heat, and 75°C. above the melting point of the salt, while it is far above the melting point of lead. The cast-iron vessel which forms the furnace is set in brick-work which reduces the loss of heat by radiation and conduction. The output of each furnace is 25 pounds of caustic per hour, which is 93 per cent. of the amount which should theoretically be produced by the current, but the voltage is considerably higher than is required by theory, as nearly half of the energy of the current is needed to keep the furnace at the high temperature of fused salt. The caustic soda in C is fused and practically anhydrous, so that it is ready for market without any boiling down, such as is required when aqueous solutions are used for electrolysis. The Acker process has been described by C. E. Acker in the Transactions of the American Electrochemical Society, vol. i., 1902, and by Prof. Richards, Electrochemical Industry, vol. i., 1902, p. 54. The works of the Acker Process Company at Niagara Falls was burned down early in the year 1907, causing a loss of \$800,000.

The Castner Sodium Process.—This is the standard method of making that metal, and no less than 3,500 tons per annum are now made in this manner. In this process, fused anhydrous caustic soda is electrolysed, using nickel for the anode, and carbon, or some metal such as iron, for the cathode. The products of the operation are sodium and hydrogen at the cathode, and oxygen at the anode, all in equal atomic proportions.

The following reactions probably take place:—

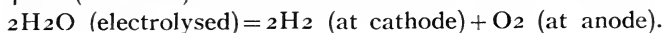
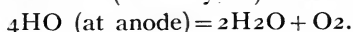
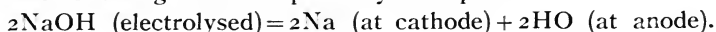

Or, put into one equation:—

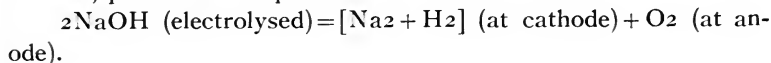

As the sodium is lighter than the fused caustic, it floats to the top, and great difficulty is experienced in preventing it from burning in the air or in the oxygen liberated at the anode, which also rises to the surface. In the Castner apparatus, Fig. 50, this is accomplished by the metal cylinder E, from the lower edge of which a cylinder of nickel gauze is continued down between the nickel anode C and the cathode D. The sodium rises within this

cylinder and collects at F, from which it may be ladled, or may overflow through a spout, while the oxygen rises outside the gauze cylinder, and is, therefore, unable to attack the sodium. The hydrogen rises with the sodium inside the cylinder and escapes through the holes in the cover. The use of the gauze cylinder allows the anode and cathode to be brought very close to each other, being only one inch apart, without danger of the sodium meeting the oxygen, and in this way the resistance of the apparatus is kept low, and a high electrical efficiency can be obtained.

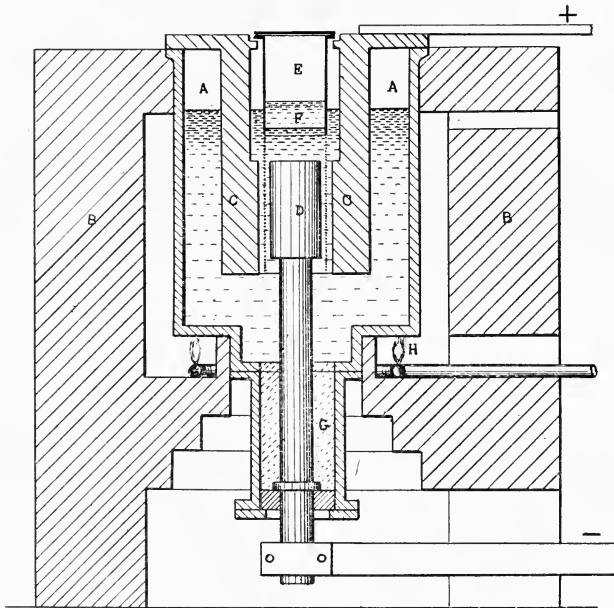

Fig. 50.—Castner's Sodium Furnace.

The apparatus consists of a cast-iron pot A, set in brickwork, B, and heated if necessary by a ring of gas burners, H, to a temperature very little above the melting point of the caustic soda. The cathode, D, is supported in position and insulated from the iron pot by means of the tube, G, which, being closed at the bottom by a ring of insulating material, such as porcelain, is filled with the fused caustic soda, which is then allowed to solidify. The tube is kept a little cooler than the rest of the apparatus, and the caustic in G, therefore, remains solid, and supports and insulates the cathode. It is very important that the

fused caustic should not be heated far above its melting point, because the sodium would then rapidly redissolve in it. The caustic melts at about 300°C., and should be kept not more than 10° above this; 90 per cent. of the theoretical quantity of sodium being then obtained. If heated 20° above its melting point no sodium would be produced, as it would dissolve as rapidly as it formed. A pot 18 inches in diameter and two feet deep will hold 250 pounds of melted caustic, and takes a current of 1,200 amperes at five volts. The current density is 2,000 amperes per square foot at the cathode and 1,500 at the anode. At the Niagara Electrochemical Company's plant in 1902* there were 120 such pots, employing, in all, 1,000 horse-power, and producing about 50 pounds each per day, or 6,000 pounds for the whole plant. The consumption of power was about four horse-power hours per pound of sodium.

Of the total annual production of sodium, about 1,500 tons are used for cyanide making, 1,500 tons for making sodium peroxide, and 500 tons are sold in the metallic state.

The Ashcroft Sodium Process.†—This is an attempt to produce sodium from common salt instead of from the more expensive caustic soda. Common salt has so high a fusing temperature that it cannot be electrolysed directly for the metal sodium, as this would be volatilized. In the Acker process sodium is produced, but only as an alloy with molten lead, from which it is recovered as caustic soda. The Ashcroft process, illustrated in Fig. 51, consists in electrolysing fused salt in a tank, A, using lead as the cathode to retain the resulting sodium, and then carrying the sodium lead alloy to a second tank, B, where it becomes the anode, in a bath of fused caustic soda kept just above its melting point. In this tank metallic sodium is liberated at the cathode, C, and floating upward is caught within the hood D, and overflows through the pipe E.

The reactions that take place can be made clear by the following equations:—

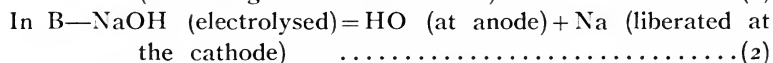
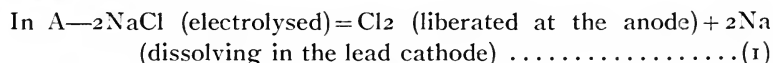

*Richards, *Electrochem. Ind.*, vol. i., 1902, p. 15.

†Ashcroft, *Trans. Am. Electrochem. Soc.*, vol. ix., 1906, p. 123; *Electrochem. and Met. Ind.*, vol. iv., 1906, p. 218.

In A, with an insoluble anode, the salt, which forms the electrolyte, is broken up into chlorine and sodium. In B, the caustic soda electrolyte is re-formed by reaction (3) as fast as it is destroyed by reaction (2).

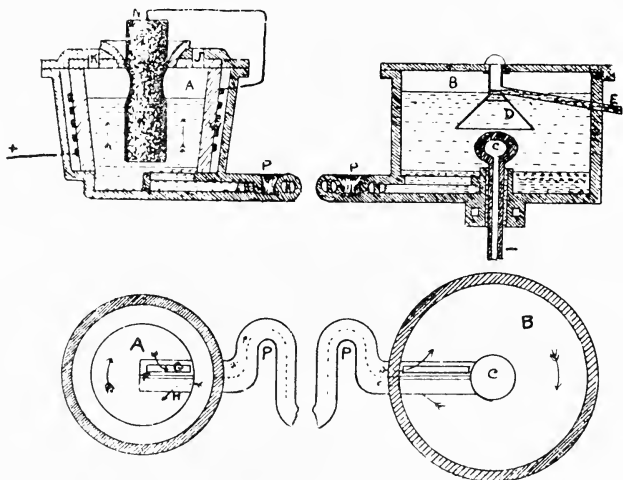

Fig. 51.—Ashcroft's Sodium Furnace.

The products of the first tank are chlorine, which is piped away and utilized, and sodium as an alloy with lead; while common salt is consumed. The second tank yields sodium only, which it takes from the lead alloy. The fused caustic, which serves as electrolyte, is not destroyed, but merely serves as a carrier for the sodium. The electric current will liberate twice as much sodium as in the Castner process, because only sodium is set free at the cathode, while in the older process equal equivalents of sodium and hydrogen were set free.

As the tank A must be hot enough to fuse salt, that is nearly 800°C ., while the tank B is little more than 300°C ., the lead sodium alloy must be cooled during its passage from A to B, and the lead returning from B to A must be reheated. This is accomplished by a twin pipe P of considerable length connecting the two vessels, so that the alloy flowing from A to B gives up its heat to the lead flowing from B to A. The pipe is folded on itself for compactness, only a part being shown in the drawing. The method of producing a continuous circulation of the lead is

also very ingenious, and consists in producing electromagnetically, a rotation of the lead alloy in A, and in providing a suitable baffle F, and openings G and H in the end of the twin pipe which enters A, so that the rotating alloy is forced to pass from A to B, circulate in B, and after giving up its sodium return to A. The openings at both ends of the twin pipe are so arranged that the richest of the alloy in A is skimmed off and passes to B, where it passes to the surface, and so gives up its sodium before returning to A. The rotation of the metal is shown by arrows in the figure. The rotation in A is caused by a coil of wire W within the cast iron tank, but separated from the molten salt by the lining of magnesite or similar material. The whole current used in the process passes through this coil and produces a strong magnetic field within A, the lines of magnetic force pointing upward as shown by the arrows. After leaving the coil the current passes to the carbon anode N, and then through the fused salt to the molten lead. The anode being small and central, and the lead cathode being more extended, the direction of the current though mainly vertical, will be partly horizontal, and so will cut the lines of magnetic force. The result will be horizontal rotation of the molten contents of A, and, as has been explained, this leads to the desired circulation of lead from A to B and back again. The tanks A and B are made of cast iron, and heated externally by fuel as well as internally by the passage of the current. A is provided with two openings, J and K, one of which has a hopper for charging in the salt, while the other serves to remove the chlorine. In B, the cathode C is globular in form, allowing the sodium which deposits around it to pass easily upwards into the hood D. The cathode is insulated from the bottom by a layer of solidified caustic as in the Castner apparatus, and is hollow, thus allowing of cooling by air or other substances if the temperature becomes too high. The hood D is connected to the iron cover of B, and thus with the sodium-lead anode, so that there is no tendency for sodium to form on any part of the tank except the cathode C. The method for producing a circulation of the lead does not sound very efficient, but it is stated to work well in a furnace using some 2,000 or 3,000 amperes, and the whole operation is reported to be working satisfactorily. The voltage needed will be about 7 volts in A, that is, the same as in the Acker process, and about 2 volts in B, or, in all, 9 volts. The process should show marked economies in comparison with the Castner method.

The alkali metal potassium strongly resembles sodium, and is obtained by electrolysis of its fused salts in practically the same manner. Magnesium, largely used for flash-lights, and the alkaline earth metals, barium, calcium and strontium, which until recently were quite rare in the metallic form, although lime, the oxide of calcium, is so common, are all obtained by the electrolysis of the fused chlorides of these metals. Calcium has also been obtained by heating calcium carbide to a very high temperature in the electric furnace. The carbide dissociates, yielding calcium vapor which can be condensed. Calcium is less violent in its reactions than sodium and will form a valuable reducing reagent in certain metallurgical operations. When calcium is added to molten steel, it is said to remove very completely not only the oxygen, but also any nitrogen that may be contained in the steel, forming a nitride of calcium. Another compound, calcium hydride, is formed by heating calcium in an atmosphere of hydrogen. It is called "hydrolith" (hydrogen stone), because, when placed in water, it liberates a large quantity of hydrogen. The hydrogen is supplied in part by the calcium, which reacts with water forming lime and hydrogen, and in part from the hydrogen contained in the calcium hydride, as shown in the equation:—

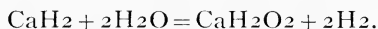

One kilogram of the hydrolith is found to yield as much as one cubic meter of hydrogen, so that it should be very valuable for inflating balloons and for other purposes.

The Swinburne and Ashcroft chlorine smelting process.—This is a method for the treatment of mixed sulphide ores such as those of zinc and lead. Although largely a chemical process, the final stage is carried out in an electric furnace, and a short account may, therefore, be given here.

The ore, consisting of sulphides of lead, zinc, iron, and manganese, with some silver, is decomposed by the action of dry chlorine at a temperature of 600°C., or 700°C., in a special vessel called a transformer, forming a fused mixture of chlorides of the metals. The sulphur comes off in the free state, and can be condensed and saved, whilst the earthy matter or gangue, from the ore, remains suspended in the fused chlorides. Enough heat is produced by the reaction to keep the transformer at the right temperature, which can be regulated by passing the chlorine more or less rapidly. When the vessel is full of chlorides they are tapped out, leaving enough behind to serve as a molten bath into

which more ore can be charged, and through which the chlorine can be passed. The molten chlorides are treated with molten lead, which serves to remove the silver, and with zinc to remove the lead. The remaining chlorides are dissolved in water, separated from the gangue by filtration, and the iron and manganese precipitated chemically by the addition of chlorine and zinc oxide, leaving a solution of zinc chloride only. This solution is evaporated, and then fused and electrolysed in a furnace shown in outline in Fig. 19, p. 30. The products are molten zinc, which is tapped off at intervals, and chlorine, which is compressed and used again for the treatment of fresh quantities of ore. The process is one of great interest, and is applicable to very many complex ores which are difficult to treat by other methods. It is self-contained, and does not require any expensive reagents, as the chlorine for the transformer is produced in the electrolysis of the zinc chloride, but the operations are somewhat complicated, and would need very careful attention. At present the only commercial installation is at a plant of the Castner-Kellner Co., which has a supply of chlorine from other processes, and uses it for the treatment of complex ores as described above, but omits the final electrolysis, obtaining the zinc in the form of chloride. Accounts of this process can be found in the "Electrochemical Industry," vol. i., p. 412; vol. ii., p. 404; vol. iii., p. 63, the transactions of the Institution of Mining and Metallurgy for 1901, and the Mineral Industry, vols. x. and xi.

Aluminium.—This is the most important metal that is produced solely in the electric furnace. Originally it was obtained by complicated chemical methods involving the use of metallic sodium as a reducing agent, but the electrical method, described on page 7, entirely supplanted the older processes. The common metals—iron, copper, lead, tin, zinc, etc.—occur in their ores as oxides, or can easily be converted into oxides by a roasting operation, and these oxides are readily reduced to the metallic state by the action of carbon in an ordinary furnace, because, at such temperatures, oxygen has a greater affinity for carbon than it has for the metal. Other metals, however, such as aluminium, calcium, and sodium, have a greater affinity for oxygen than those already mentioned, and it is very difficult, and in some cases impossible, to reduce the oxides of these metals by means of carbon at ordinary furnace temperatures. With the aid of electricity, however, any metal can be reduced, either by heating the oxide to a very high temperature, at which the affinity between the metal and

oxygen is lessened, so that the latter can be removed by means of carbon, or by dissolving the oxide or other ore of the metal in a suitable solvent, and applying an electrical force to tear the compound into two parts by electrolysis, thus liberating the metal. Aluminium, calcium, and other metals can be reduced by carbon at the high temperature of the electric furnace, but immediately combine with a further quantity of carbon, forming carbides. It is, therefore, necessary, when the pure metal is desired, to employ electrolysis instead of the direct reduction with carbon.

Aluminium has been termed "Silver from Clay" as it forms some 15 or 20 per cent. of ordinary clay, but the expense of extracting aluminium from clay would be so great that the richer

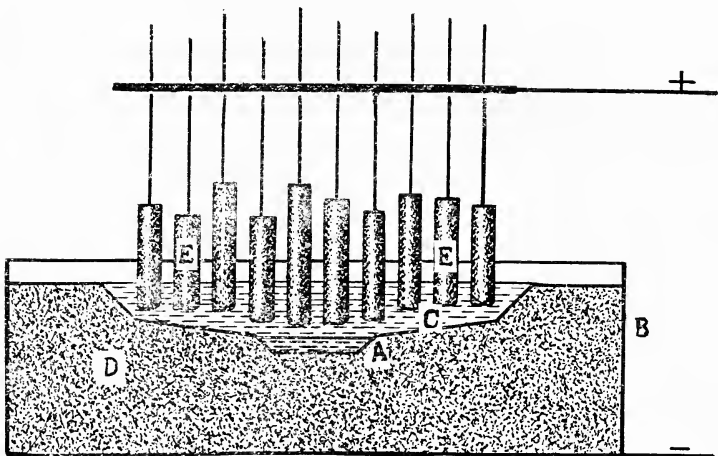
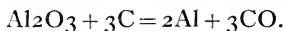

Fig. 52.—Aluminium Furnace.

ore, bauxite, is always employed as a source of this metal. Bauxite consists of alumina, the oxide of aluminium, combined with some water and associated with silica, oxide of iron, etc. If the natural bauxite were merely calcined to remove the water and then electrolysed in the electric furnace, the iron and silicon would be reduced more readily than the aluminium. The resulting metal would therefore be impure and would be almost useless for most of the purposes to which aluminium is applied, though an impure metal, obtained in this way, would serve for the production of high temperatures by Dr. Goldschmidt's Thermit process. For the production of the pure metal the bauxite must be purified before being introduced into the electrolytic furnace.

One method of effecting this was to digest the calcined bauxite in a solution of caustic soda. This dissolved the alumina which was subsequently precipitated from the solution. A more recent process, that of Hall, consists in mixing the calcined bauxite with a sufficient proportion of carbon or aluminium to reduce the whole of the impurities to the metallic state. The mixture is then charged into a carbon lined electric furnace and melted. The iron, silicon and other impurities are reduced to the metallic state and collect at the bottom of the melted mass, leaving a pure fused alumina suitable for use in the electrolytic furnace.

The production of aluminium from alumina is effected by electrolysis as described in outline on page 7, Fig. 52* represents diagrammatically a furnace used by the Pittsburg Reduction Company. The furnace consists of an iron casing, B, thickly lined with carbon, D, and containing the fused electrolyte, C, and aluminium, A. A number of electrodes of specially pure carbon E E, form the anode, while the carbon lining, D, and aluminium, A, form the cathode of the furnace. The carbon lining is very thick, thus reducing the loss of heat, and is provided with a sump for holding the aluminium when it is formed. A tapping hole and spout, leading from this sump, are also provided though not shown in the figure. The electrolyte consists of alumina dissolved in the fluorides of sodium, aluminium, and possibly calcium. The fluorides are not decomposed but merely serve as a solvent for the alumina. Electrolysis of the alumina yields aluminium at the cathode and oxygen at the anode. The oxygen combines with the carbon of the anodes as shown in this equation:—



Only a small proportion of alumina can be dissolved by the fluorides, without unduly raising the temperature of the furnace, but a quantity of alumina is placed on the top of the electrolyte and stirred in from time to time as required. It is desirable that the furnace should be worked at a low temperature and with a low current density, as a high temperature leads to the resolution of the deposited metal in the electrolyte, and a high current density causes the fluorides to be decomposed liberating sodium and fluorine. The melting temperature of the most fusible mixture of cryolite, the natural fluoride of aluminium and sodium, and alumina has been found to be $915^\circ\text{C}.$,† but it has

*From a drawing by Prof. J. W. Richards in the Journal of the Franklin Institute, May, 1896.

†F. R. Pyne, Trans. Amer. Electrochem. Soc., vol. x., p. 63.

been stated that in recent practice the aluminium furnace is worked at 750°C . or 800°C .

The aluminium industry is growing rapidly at the present time, and an extended use of the metal will no doubt follow the larger supply. Prof. Richards* gives the total production of aluminium in 1906 as not far short of 19,000 metric tons, valued at \$12,500,000, and says that the output in 1907 will probably be twice as great as in 1906, and that in 1908 the production of aluminium will probably be twice as great as in 1907.

*J. W. Richards, *Engineering and Mining Journal*, vol. lxxxiii, p. 1083, and the *Mineral Industry*, vol. xv.

CHAPTER VII.

Future Developments of the Electric Furnace.

In this concluding chapter, an attempt may be made to indicate in what directions future developments of the electric furnace may be expected, and to what extent this development is likely to proceed. Such an attempt can hardly fail to prove incorrect, however, on account of the great changes that take place in the economic conditions of the world, as well as on account of the discoveries and improvements which are made with increasing frequency.

The following questions may be asked:—

1. How far will the electric current replace fuel in furnaces for the smelting and refining of metals?
2. What untouched fields of usefulness are waiting for the electric furnace?
3. What limits are there to the commercial development of the electric furnace?

Electric furnace operations may be roughly divided into two classes, first, those which can scarcely be effected in any other way, and in which electrical heating must always hold the field, such as the production of calcium carbide, carborundum, and aluminium. Second, those in which either fuel or electrical heat may be used with a fair measure of efficiency, and in which the price of the two sources of heat must be compared, in addition to the efficiency of each, before deciding which to employ.

The relative prices of coal and electrical energy, and the amount of electrical power that will be available, are considerations of the first importance in determining the future of the electric furnace.

Until a few years ago the electric current was a wonderful and expensive commodity, and the idea of using it for heating on a commercial scale was preposterous. About 13 tons of coal were needed to produce one electrical horse-power for a year, and this electrical energy, would furnish less heat than one ton of the original coal. Such a method of using coal was evidently extremely wasteful. The greater efficiency of electrical heating somewhat reduces this difference, and together with the smaller cost of water-power has made it cheaper in some cases to use "white coal" instead of black, in the furnace.

In comparing the supplies and prices of coal and electrical energy, it should be remembered that one ton of good coal produces as much heat as $1\frac{1}{3}$ horse-power years of electrical energy, but that the efficiency of the electrical furnace is from 2 to 30 times as great as the efficiency of ordinary metallurgical furnaces, so that an electrical horse-power year will produce as much effective heat as several tons of coal. The figures for different operations are given in Chapter III., page 34.

The world's production of coal at the present time is about 1,000 million tons a year, and is steadily increasing. The electric furnace draws its energy mainly from water-powers. The water-powers of the world that have already been utilized are very small in comparison with the present coal output, having in all only about 1 per cent. of the heating power of the latter.

In view of the fact that coal mining is a long-established industry, while the electrification of water-powers is only of recent growth, it is reasonable to suppose that the latter will increase more quickly in proportion than the former. In both cases there are limits, however; the coal mines will ultimately all be discovered and worked out to a depth at which the cost becomes almost prohibitory, while on the other hand the water-powers will all be developed, leaving only those that are too expensive to utilize. When these limits are reached the coal supply will have sunk to a small proportion of the amount needed for heating and power, but the water-powers will continue to give a steady supply of power for all time with only maintenance and interest charges.

The exhaustion of coal supplies may not be reached for hundreds or thousands of years, but if the development of the mines proceeds, as at present, at increasing rates like compound interest, their practical depletion may be less distant than now appears probable. In any case it seems likely that as coal can only be used once, while water-powers are not deteriorated by use, the latter may be expected ultimately to largely replace the former for motive power and to some extent for furnace work.

The present age, especially on this continent, is one of the barbaric use of the mineral assets such as coal and ore. As the population increases and the development of mines is pushed to its limit, the increasing scarcity both of the ore and of the fuel to smelt it, will make it necessary to spend more money in utilizing these to the very best advantage, using the coal with the greatest economy and extracting every possible product from the ore. It has been suggested that the present enormous production of iron and steel for example can only represent a temporary

condition, that of extracting the iron from its ore. When most of the iron ores have been converted into iron or steel our descendants will have to be content to use over again the metal so produced, merely making good the deficiency caused by rusting and the increase in population. Iron is, however, a very plentiful metal, forming perhaps 4 or 5 per cent. of the earth's crust, and the coal will last for a large number of years, but the time must come when it would be extravagant to use coal, mined at great expense, for the mere production of heat. As coal becomes more scarce it will be used for its chemical properties of reducing iron and other metals from their ores, while the necessary heat would be produced electrically. At that time Canadians may have to heat their houses electrically, or if, on account of the large population in Canada at that time, such method of heating were too expensive, they may have to live underground during the winter.

In the more immediate future there will no doubt be a great development of electrical power, which may in consequence replace coal to some extent in furnace operations such as the production of steel and iron from certain ores, and in certain localities; on the other hand the rapidly increasing market for electrical power will tend to keep the price from falling, relatively to the price of coal, and it is therefore unlikely that coal and coke will be at all largely replaced for smelting purposes by the electric current for many years to come.

When the possibilities of the electric furnace have been more fully ascertained it is likely that some large water-powers that are situated conveniently with regard to metallic ores may be utilized for their reduction, the electric plant being available for other purposes after the exhaustion of the ore supply. At the present time such a large return can be obtained from capital in Canadian industries that only the most easily developed water-powers are considered. When the country becomes more thickly settled and when capital is more abundant, a smaller return will be expected and the interest charges on permanent developments such as hydro-electric plants will be less; thus enabling powers to be utilized that would be too costly under present conditions.

With regard to the probable future developments of the electric furnace it will be instructive to review shortly the progress that has already been made:—

I. The electric furnace has rendered available a range of temperature from about $1,800^{\circ}\text{C.}$ to about $3,700^{\circ}\text{C.}$, which could

not previously be reached, or in other words it has doubled the available range of temperatures above the freezing point.

II. In the electric furnace substances can be heated to any temperature within this increased range with the complete exclusion of air or furnace gases, while with other furnaces it was very difficult and sometimes impossible to exclude the furnace gases from the substance to be heated.

III. The greater efficiency of the electric furnace, over the fuel furnace, which is particularly noticeable at high temperatures, has enabled the electric current, although more expensive, to replace fuel for certain purposes.

IV. The electrolytic furnace enables a direct electric tension to be applied to break up compounds that cannot be dealt with by the ordinary chemical reactions at high temperatures.

The increased range of temperature that is now available has resulted in a complete new chemistry of high temperatures. At these temperatures all metals are reduced from their oxides by carbon, and many of them unite with more carbon to form carbides, some of which have valuable properties. Other compounds such as silicides and borides have also been obtained and studied. No doubt in the future many other compounds will be obtained, from the elements silicon, carbon, calcium, oxygen, and aluminium, which form such a large proportion of the earth's crust, as the work that has already been done in this direction can only be considered to have scratched lightly in the virgin soil that has been placed at our disposal. Counting in the other elements, it will be seen what an immense field for discovery lies open to those who are working with the electric furnace. Another power furnished by the electric furnace is the ability to separate and purify substances by fractional distillation at these high temperatures. What could formerly be done by the chemist in the separation of organic liquids by distillation in glass vessels can now be effected in the electric furnace in the case of such bodies as iron, lime and silica, not to mention the more fusible metals such as gold and silver. The removal by distillation in the electric furnace of the ash forming matters from anthracite, during its conversion into graphite, is one commercial example of a process which will no doubt be largely employed in the future.

The high temperatures that can be obtained, together with the ease with which air can be excluded, and the high efficiency even at high temperatures, has made it economical to smelt

electrically such metals as chromium, manganese, tungsten, titanium, and the element silicon, whose reduction had been difficult, expensive, and incomplete in ordinary furnaces. Other elements will, no doubt, be added to this list, and a large number of alloys and compounds of these will certainly be discovered.

The electrolytic furnace has already enabled aluminium, sodium, potassium, magnesium, calcium, barium, strontium, and other metals to be obtained from their fused salts, together with chlorine and other substances. Although most of the ordinary metals that are amenable to this treatment must have been experimented with already, there are no doubt many new processes of this character waiting to be discovered, and it seems likely that a far greater use can be made of the alkali and alkaline earth metals that have been made available in quantity by this means.

The very high temperature of the electric furnace has enabled it to be used for melting refractory metals and still more refractory substances such as silica, lime, magnesia and alumina. The possibility of fusing these substances in quantity will lead to fresh uses of these and other materials. The conversion of amorphous carbon into graphite is an example of a physical change in an elementary substance at a high temperature, that may not soon be duplicated, though the problem of its conversion into the diamond is still unsolved commercially.

One very important use of the electric furnace is for experimental work in the laboratory. Here the item of cost is not a matter of great importance as the operations are usually small and occasional. The results of such experimental work are frequently very important and far-reaching. For such purposes the electric furnace will be increasingly employed, and standard forms will be devised for heating substances, and carrying out reactions with the complete absence of oxygen, carbon, or other objectionable substance. Vacuum and pressure furnaces will also be constructed and employed.

One probable development of the electric furnace in the near future is made possible by the intermittent use that is made of electric power for lighting and motor purposes. When electric power is produced hydraulically, large quantities could be sold for electric furnace work at moderate prices provided it were only used between certain hours. Although the smelting of ores could hardly be carried on in this intermittent fashion, there are many purposes for which electrical heat could be applied in this way. One of these has been suggested by Richard

Moldenke in an article entitled "Electric Smelting for the Foundry,"* in which he suggests that foundrymen should make their own steel castings by means of the electric furnace, preferably the induction furnace; that even iron castings would be made better in this way than in the cupola, and that the electric furnace would be ideal for brass melting. Such operations could, of course, be conducted continuously, or as has been suggested above, intermittently so as to obtain the power more cheaply.

In conclusion it should be remembered that water-powers are not the only available source of electrical power for furnace work. One other important source of such power is the waste gas from the iron blast furnace. This if used in large gas engines will frequently furnish a considerable amount of power in excess of what is needed for running the plant, and this excess could be used for the electric smelting of steel or similar purposes. Prof. J. W. Richards† has stated that there is as much as 1,000,000 horse-power available from this source in the United States alone.

For some electric furnace processes even coal burned in steam boilers may be used to generate power, but a considerable saving can now be effected by the use of coal, which need not even be of very good quality, in gas producers for running large gas engines.

Other sources of electric power, which may be used in the future, when the price of coal is getting higher, are the immense movements of water known as the tides. Attempts have also been made to harness the ocean waves whose great power is attested by many rock bound coasts, and although their irregularity renders them unsuitable for electric lighting and other uses of electricity where constancy is an essential factor, it would seem possible that certain smelting operations could be conducted in this way.

The strides of physical science in recent years have been so enormous that there seems to be no limit to what may ultimately be possible, and if in the future we are able, as suggested by Lord Kelvin, to draw endless supplies of power from the ether itself, we can await with quiet minds the exhaustion of the coal supplies of the world.

*Electro-chemical and Metallurgical Industry, vol. v., 1907, p. 42.

†Trans. Am. Electrochem. Soc., vol. iii., 1903, p. 67.

INDEX.

A

- Acetylene, 10, 154-155.
- Acheson, E. G., 10, 11, 54, 65, 143, 144, 146, 149, 153.
furnaces, 11, 12, 24, 26, 64, 65, 72, 76, 79, 145, 149, 150.
graphite, 148, 149.
graphite company, 77, 144, 146, 148.
(see also carborundum, electrodes, graphite and siloxicon).
- Achievements of electric furnaces, 191.
- Acker, caustic soda process, 177-179, 181, 183.
- Air-cooling of furnaces, 35, 57, 58, 59, 157-158.
in furnaces, 193.
nitrates and nitric acid from air, 173-174.
- Albro, use of silicon for heating, 172.
- Allevard, electric steel furnace at, 107.
- Alloys, aluminium, 6, 186.
copper, 6, 172.
ferro-, 12, 136-142.
silicon, 172.
- Alternating current, 29, 68, 69, 93-103, 109, 167, 173.
- Alumina, ore of aluminium, 6, 7, 52, 186-187.
refractory material, 52, 55, 56, 57.
- Aluminium, 40, 52.
alloys, 6, 186.
furnaces, 53, 186-188.
Hall and Heroult processes, 6, 7.
heat from, 172, 186.
production of, 7, 185-188.
uses of, 138.
- Alundum, 173.
- American Electric Furnace Company, induction furnaces, 96, 98.
- American Electrochemical Society Transactions, 50, 77, 78, 83, 84,
106, 148, 172, 181, 187, 194.
- American fire-brick, 49.
- Ammeter, 15, 16.
- Amorphous carbon, 53, 76, 77, 78, 79, 80, 142, 143, 147, 148, 149.
graphite, 142.
- Amperes, 16, 60-66, 67, 72, 79-80, (see also the individual furnaces).
- Analyses, ferro-alloys, 139-140.
iron ores, 121, 125, 126, 133.
pig iron, 127.
silicon, 171.
slag, 134.
steel, 45, 47, 132, 134.
zinc ores, 165, 170.
- Andreoli, quotation from, 3.
- Anode, 174-187.
- Anthracite, calorific power of, 43.
- Araya, Spain, induction steel furnace at, 99.

A.

- Arc, electric, 1, 2, 3, 19, 21, 32, 53, 61, 67, 173.
 furnaces, 1, 3, 4, 5, 8, 10, 19, 20, 60-62, 66-69, 71, 74, 87-92, 129-131, 159, 173.
 furnaces, direct-heating, 19-20, 32, (see Girod, Heroult, Higgins, Salgues, Siemens, and Willson).
 furnaces, independent, 19, 32, see Birkeland and Eyde, Moissan, Siemens, and Stassano.
 light, 1, 2.
 resistance of, 67.
 voltage of, 60-62, 67-69, 173.
- Arsem, vacuum electric furnace, 83.
- Ashcroft, sodium process, 181-183.
- Ashcroft and Swinburne, chlorine smelting process, 184-185.

B

- Baird, California, electric smelting of iron ores, 14, 107, 121.
- Balance sheet of heat, 46.
- Barium, 193.
- Barnes, Dr. H. T., specific heat of water, 38.
- Barus, thermo-electric pyrometry, 82.
- Battery, electric, 1, 3.
- Bauxite, ore of aluminium, 52, 186-187.
 refractory material, 52, 55, 56.
- Beard, heat insulation, 56.
- Becket, F. M., use of silicon for reducing metals, 141, 172.
 water-jackets for electrodes, 80.
- Bennie, P. McN., Gin steel furnace, 105.
- Bergamo, Italy, zinc in electric furnace at, 170.
- Bertani, and Casaretti, zinc in electric furnace, 170.
- Bessemer furnace, 86, 91, 92.
 steel, 12, 85, 86.
- Birkeland and Eyde, nitric acid in electric furnace, 173.
- Bisulphide of carbon, production in electric furnace, 174.
- Bituminous coal, calorific power of, 43-44.
 use of in electric furnace, 124.
- Blast furnace, coke used in, 13, 41, 110.
 efficiency, 41, 123, 128.
 elimination of sulphur and phosphorus, 132.
- Boiling temperature of carbon, 53, 55.
- Borchers, Dr. W., 9.
 electric furnaces, 24, 60, 76, 80.
 "Electric Smelting and Refining," 3, 4, 5, 6, 24, 155.
- Boudouard, O., temperature measurements, 50, 52, 53, 56, 82.
- Boys, C. V., quartz filaments, 172.
- Brass, 40.
- Bricks, refractory, 49-58, (see also alumina, bauxite, carbon, dolomite, fire-clay, magnesia, and silica).
- Bristol, W. H., electric furnace, 22.
 thermo-electric pyrometer, 83.
- British thermal unit, 33, 38-39, 40, 43.
- Bronze, aluminium, 6.
 in construction of electric furnaces, 80, 87, 152.
- Brown, W. G., steel from ore in electric furnace, 133.
- Bunsen battery, 3.
- Burgess, G. K., pyrometry, 82, 83.

B

- Burning gases from electric furnace, 6, 10, 110, 113, 115, 120, 122-128, 131, 164.
 heat from burning fuel, 33, 36, 39, 41-44.

C

- Cables, electric, 15-18, 67, 80, 81, 105, 106, 108, 117, 119.
 Calcium, 10, 99, 184, 193.
 carbide, 9, 10, 12, 51, 154-155.
 hydride, 184.
 nitrate, 173-174.
 California, electric smelting in, 14, 121.
 Callender, resistance pyrometer, 82.
 Calorie, 38, 46.
 Calorific power of fuels, and electrical energy, 33, 36, 39, 41-44.
 Calorimeter, 41, 42.
 Calorite, substitute for thermit, 172.
 Canada, electric heat in, 191.
 electric smelting in, 13, 14, 36.
 Canadian iron ores, 121.
 Government Commission, 13, etc., (see Haanel).
 Capacity of electric furnaces, 45, 88, 90, 91, 92, 95, 96, 99, 100, 106, 132, 144.
 Carbide of calcium, 9, 10, 12, 53, 154-155.
 silicon, (see carborundum).
 Carbides, 9-12, 136, 149-155.
 Carbon, amorphous, 53, 76, 77, 78, 79, 80, 142, 143, 147, 148, 149.
 blocks, 25, 26, 53.
 boiling point of, 53, 55.
 calorific power of, 43.
 crucibles, 8.
 diamond, 3, 53, 142.
 electrodes, 1, 2, 4, 5, 6, 17, 23, 48, 53, 77, 78, 79, 80, 81, 131.
 furnace linings, 8, 12, 53, 54, 108, 112, 117, 119.
 graphitic, (see also graphite), 53.
 for reducing ores, 86, 107-135, 137, 138, 155-170, 191.
 in iron and steel, 12, 85, 125, 127, 129, 134.
 National carbon company, 77.
 pole or point, 1, 2.
 refractory material, 8, 53, 55, 108.
 resistivity, 53.
 retort carbon, 6, 54, 79.
 rods, 2, 24, 144, 146, 149, 152, 153.
 tubes, 23.
 vapour, 2.
 Carbon bisulphide, 174.
 Carbon monoxide, calorific power of, 43.
 Carborundum, 10-12, 54-57, 150-153.
 discovery of, 10, 149.
 furnace, 11, 12, 24, 150-153, (see Acheson).
 uses, 11, 54, 55, 56, 153.
 fire-sand, 54, 55, 56, 57, 152.
 Carburite, 46.
 Casaretti and Bertani, electric zinc smelting, 170.
 Casing of furnaces, 17, 23, 48, 59, 87, 94, 98, 103, 108, 109, 113, 115, 120, 129, 130, 161, 169.

C.

- Casting of metals, frontispiece, 96, 194.
- Cast iron, 40, 85.
- Castner, sodium process and furnace, 179-181, 182.
- Castner Kellner Company, chlorine smelting process, 185.
- Cathode, 2, 174-187.
- Caustic soda, Acker's process and furnace, 177-179.
electrolysis, 179-183.
- Champagne (Ariege) France, electric zinc smelting at, 161.
- Chappuis, thermo-electric pyrometry, 82.
- Charcoal, calorific power of, 43-44.
for reduction of ores, 109, 110, 111, 115, 120, 124, 125, 126,
127, 128.
furnace lining, 3, 6, 53.
- Charging and discharging furnaces, 17, (see also individual furnaces).
- Chats Falls, cost of electric power from, 34.
- Chemical energy, 16, 176.
- Chlorine, 30-31, 177-179, 184-185.
- Chromite, 52, 106.
- Chromium, 12, 136-141.
- Clarke, Dr. F. W., Silicon in earth's crust, 171.
- Classification of electric furnaces, 18-32.
- Clay, (see fire-clay), 49-50, 54, 55, 57, 58, 98.
- Coal, calorific power of, 33, 43-44.
supplies of, 189-191.
use of in electric furnace, 124.
- Coal gas, calorific power of, 43, 44.
- Coke, calorific power of, 43, 44.
for cores of electric furnaces, 74, 75, 76.
for crucible steel furnaces, 34, 36, 39.
for iron blast-furnace, 13, 41, 110.
for lining electric furnaces, 53.
for reduction of ores, 124, 128.
graphitized, 76.
resistivity of, 53.
- Colby, induction steel furnace, 13, 30, 96-99, 101.
- Collins, (or Collens), C. L., Uses of Acheson Graphite, 148.
- Conclusions, 83-84.
- Conduction of heat, 57, 58.
- Conductivity of molten metals, 72, 78, 101, 105.
molten slags, 74, 78.
- Conley, electric furnace, 23.
- Construction of electric furnaces, 17, 48-84.
- Consumption of electrical energy in electric furnaces, 46, 47, 48, 49,
58, 89, 90, 92, 96, 98, 100, 111, 113, 125, 126, 127, 128,
131, 137, 153, 170.
of electrodes, 80, 131.
- Contents of electric furnaces, solid, 26, 32, (see also individual
furnaces).
melting, 26-28, 32, 66, 69, (see also
individual furnaces).
liquid, 28-32, 72, (see also individual
furnaces).
- Continuous electric furnaces, 10, 17, 49.
- Cooling of electrodes by water, 4, 5, 59, 60, 80, 81, 87, 105, 130, 173.
furnaces, by air, 35, 57, 58, 59, 157-158.
by water, 29, 57, 58-60, 94, 97, 161.

C.

- Copper, aluminium alloys, 6.
 cables, 15-18, 67, 80, 81, 105, 106, 108, 117, 119.
 construction of electric furnaces, 80, 97, 98, 103, 109, 115,
 152, 167.
 melting temperature and heat required to melt, 40.
 silicon alloys, 172.
 vaporized, 5.
- Cores of resistance furnaces, 18, 24, 25, 26, 74, 75, 144, 146, 149, 150, 151.
 broken coke, 74, 75, 76, 151, 152.
 carbon blocks, 25, 26.
 carbon rods, 24, 144, 146, 149.
 construction of, 25, 151, 153.
 multiple cores, 153-154.
 resistance of, 24, 75-78, 144-152.
 retort carbon, 6.
- Corundum, artificial, 173.
- Cost of fuel and electrical power, 13, 33, 34, 36, 37, 47, 90, 96, 121,
 189, 190, 191, 193, 194.
 electrical smelting, 73, 92, 128.
 electrodes, 90, 131.
 pig-iron, 121.
 steel, 47, 90, 135.
- Cowles, E. H. and A. H., 5, 6, 26, 157.
 aluminium furnace, 10.
 electric zinc furnace, 157.
- Crocker, F. B., "Electric lighting," 67.
- Crucible, 8, 54, 94, 96, 97, 98, 142, 143.
 electric furnace, 3, 4, 5, 22, (see Bristol, Colby, Evans, Girod,
 Howe, McGill, Napier, Siemens).
 steel furnace, 34, 35, 36, 86, 94.
 steel, 85, 86, 88, 89, 91, 97.
- Cryolite, 7, 187.
- Crystalline graphite, 142.
- Current, alternating, 29, 68, 69, 87, 93-103, 109, 173.
 continuous or direct, 30, 165, 174.
 electric, 2, 3, 15-18, (and under other headings).

D.

- Davy, Sir Humphry, 1.
 Definition of electric furnace, 15.
- De Laval electric furnaces, 28, 29, 59, 72, 80, 135, 158, 159.
- Demond, C. D., temperature measurements, 49, 82.
- Design of electric furnaces, 48-84.
- Despretz, electric furnace, 3.
- Development of electric furnaces, 1, 3, 189-194.
- Diamond, a form of carbon, 3, 53, 142.
 production of, in electric furnace, 3, 7, 9, 142.
- Direct current arc, 2.
- Direct-heating arc furnace, 19-20, 32, (see Girod, Heroult, Higgins,
 Salgues, Siemens, Willson).
- Direct or continuous current, 30, 165, 174.
- Direct production of steel from the ore, 129-135.
- Disc of flame, 173.
 shaped furnace, 173.

D.

- Discovery of carborundum, 10, 149.
 electric arc, 1.
 electric battery, 1.
 electric furnace graphite, 11, 143.
 principle of electrical heating, 3.
- Dissociation of silicon carbides, 55, 56, 143, 147, 149, 152, 153.
- Distillation of metals in electric furnace, 5, 8, 147, 192.
 zinc, 157-170.
- Diston, Henry and Sons, Colby induction steel furnace, frontispiece,
 97, 99.
- Dolomite, refractory material, 52, 87, 94, 113.
 lining for electric furnace, 87, 88, 94, 112, 113.
- Duesseldorf, carborundum plant at, 153.
- Dupre, A., explosive gas from ferro-silicon, 141.
- Dynamo electric, 3, 15, 16, 18, 167.

E

- Edstrom, J. S., electrical extraction of nitrogen from the air, 173.
- Efficiency of furnaces, 33-47, 123-128, 192.
 calculation of, 37-46.
 used for melting metals, 34, 36.
- Eichhoff, Prof., operation of Heroult steel furnace, 89.
- Electric arc, 1, 2, 3, 53.
 arc furnace, (see arc furnaces).
 battery, 1, 3.
 cables, 15, 16, 17, 18, 80, 81, 105, 106, 108, 117, 119.
 circuit, 15, 16.
 current, 2, 3, 15-18, (see also other headings).
 dynamo, 3, 15, 16, 18.
 energy, amount used in furnaces, 46, 47, 48, 49, 58, 80, 90, 92,
 96, 98, 100, 111, 113, 125, 126, 127, 128, 131, 137,
 153, 170.
 heating power of, 15-17, 33, 43, 46, 189-194.
- furnaces, (see arc continuous, crucible, electrolytic, experi-
 mental, ideal, induction, intermittent, pressure, resistance,
 smelting, tube, vacuum).
 see aluminium, alundum, barium, calcium, calcium
 carbide, calcium nitrate, caustic soda, carbon bisulphide,
 carborundum, chlorine, copper, diamond, ferro-alloys,
 fused-quartz, glass, graphite, graphite electrodes, iron,
 nitrates and nitric acid, phosphorus, platinum, potassium,
 siloxicon, sodium, steel, strontium, zinc.
 see Acheson, Acker, Arsem, Ashcroft, Birkeland,
 Borchers, Bristol, Castner, Colby, Conley, Cowles, Des-
 pretz, Evans, Eyde, Faure, Gin, Girod, Gronwall, Haanel,
 Hall, Harmet, Harker, Heroult, Higgins, Howe, Imray,
 Ischewsky, Jacobs, Johnson, Keller, Kjellin, Laval, Lind-
 blad, McGill, Moissan, Napier, Patterson, Pepys, Pichou,
 Potter, Reynolds, Ruthenburg, Salgues, Siemens, Snyder,
 Stansfield, Stassano, Swinburne, Tone, Tucker, Turnbull,
 Willson.
 see achievements, air-cooling, classification, construc-
 tion, cores, costs, current, current-density, definition, de-
 sign, development, dimensions, discovery, distillation,

E.

Electric furnaces, continued.

- efficiency, electrodes, envelope, future, heat, history, linings, materials of construction, measurements, operation, output, production, regulation, resistance, resisting-contents, resistors, tapping, temperature, uses, voltage, walls, water-cooling.
- furnace company, American, induction furnaces, 96, 98.
- heat, 2, 6, 15, 16, 33, 43, 189-194.
- horse-power-year, heating value of, 33, 43, 190
- inductance, 17, 101, 103.
- inertia, 17.
- light, 1, 2.
- power used in furnaces, 3, 8, 12, 45, 46, 60-66, 68, 69, 70, 72, 73, 89, 90, 93, 95, 96, 98, 99, 100, 106, 120, 121, 131, 137, 138, 146, 150, 152, 155, 160, 161, 165, 170, 173, 178, 181, 183, 190.
- resistance, 15-17.
- resistivity, 76-78.
- transformers, 18, 67, 93, 94, 97, 101, 102, 105, 108, 117, 119.
- voltage, 66-71, (see also individual furnaces).
- Electrical Metallurgical Company, ferro-alloys in electric furnaces, 138.
- Electrochemical and Metallurgical Industry, frequent references.
- Electrochemical Society, American, transactions of, (see American).
- Electrodes, 1, 2, 4, 5, 17, 53, 59, 60, 67, 71, 77, 78, 79, 80, 81, 113, (see also individual furnaces).
 - central, 27, 28.
 - copper, 5, 175, 177.
 - holders, 11, 17, 80-81.
 - lateral, 26, 27.
 - positive, 4, 5.
 - water-cooled, 4, 5, 59, 60, 80, 81, 130, 173.
- Electrolysis, 2, 6, 30-31, 32, 165, 174-177.
- Electrolytic furnaces, 7, 15, 30-31, 32, 177-183, 187, 192, (see also, Acker, Ashcroft, Castner, Hall, Heroult, Swinburne).
- Electro-magnet, 173.
- Electrons, 2.
- Electro-quartz, 172.
- Energy used in electric furnaces, (see electric energy).
- Engelhardt, V., operation of induction furnace, 95, 100.
- England, steel in electric furnace in, 36, 99.
- Envelope refractory of electric furnace, 17, 48.
- Essen, Germany, electric steel furnaces at, 99, 106.
- Essential parts of electric furnace, 17.
- Ethylene, C_2H_4 , calorific power of, 43.
- European Commission Report, (see Haanel).
- Europe, electric smelting of iron and steel, in, 13.
 - electric zinc smelting in, 160.
- Evans, J. W., steel from ore in electric furnace, 132-134.
- Evaporative heat unit, 38-39.
- Expansion and contraction of refractory materials, 50, 51.
- Experimental electric furnaces, 21, 22, 23, 163-164, 193.
- Experiments at Sault Ste. Marie, (see Haanel).
- Eyde and Birkeland, nitric acid from air, in electric furnace, 173.

F

- Faure, electric resistance furnace, 5.
- Ferro-alloys, 12, 136-142.
 chromium, 12, 136-142.
 manganese, 12, 136-141.
 molybdenum, 12, 138, 140, 141.
 nickel, 12.
 silicon, 12, 136-142.
 titanium, 12, 136-141.
 tungsten, 12, 136-141.
 vanadium, 138, 140, 141.
- Ferro-alloy works, Girod, 138-139.
- Fery, optical measurement of temperature of arc, 53.
- Fire-clay, 49-50, 54, 55, 57, 58, 98, 157.
- FitzGerald, F. A. J., electric furnace design and Acheson furnaces and furnace products, 11, 23, 54, 65, 73, 75, 77, 83, 143, 146, 152, 153.
- Forssell and FitzGerald, resistivity of carbon, 77.
- France, electric furnaces in, 12, 45, 113, 160.
- "Fuel and Refractory Materials," A. H. Sexton, 49, 50, 51, 52.
- Fuel, calorific power of, 33, 36, 39, 41, 42, 43, 44.
 oil, calorific power of, 43.
- Furnaces, Bessemer, 86, 91.
 blast, 13, 85, 107, 110, 111, 112, 121, 128, 129.
 charging and discharging, 17, (see also individual furnaces).
 construction, 17, 48-84.
 continuous, 10, 17, 49
 crucible furnace, 34, 35, 36.
 design, 48-84.
 electric, (see electric furnaces).
 efficiency, 33-46, 123-128, 192.
 intermittent, 7, 10, 48.
 linings, (see linings of furnaces).
 operation, 48-84.
 open-hearth, 34-35, 36, 50, 86, 88, 90, 92, 132, 135.
 reverberatory, 34-35, 36.
 shaft, 34-35, 135.
- Fused-quartz, 22, 172.
 magnesia, 52.
- Future developments of electric furnace, 189-194.

G

- Gas carbon, 6.
 coal gas, calorific power of, 43-44.
 from electric furnaces, 6, 10, 35, 110, 113, 115, 120, 122-128, 130,
 131, 156, 157, 164.
 in furnaces, 5, 167, 173.
- Germany, electric steel furnaces in, 36, 91, 99, 106, 131.
- Gin, steel furnaces, 30, 60, 64, 66, 72, 78, 80, 86, 101, 104, 105, 106, 107.
- Girod, electric furnaces and ferro-alloys, 106, 107, 138.
- Glass in electric furnace, 172-173.
- Goldschmidt, Dr., Stassano steel furnace, 61, 131, 135.
 thermit process, 141, 172, 186.
- Gram-calorie, 38, 39.

G.

- Graphite, 142-149.
 Acheson, 11, 12, 143-149.
 amorphous, 142.
 Company, Acheson, 77, 144, 146, 148.
 crucibles, 97-98, 142, 143.
 crystalline, 142.
 electric, 9, 11, 12, 143-149.
 electrodes, 53, 144-148
 furnace, 26, 144-149, (see Acheson).
 packing, 115.
 refractory material, 53, 54, 98, 142, 143.
 soft, 149.
- Gray, G. W., analysis of ferro-alloys, 139.
- Gronwall furnace, 30, 101.
- Guldsmeshyttan, Sweden, induction steel furnace at, 99.
- Gysinge, Sweden, induction steel furnace at, 93-96, 99.

H

- Haanel, Dr. E., 13, 14, 67.
 Report of European Commission, 14, 34, 45, 62, 63,
 64, 69, 70, 71, 78, 81, 86, 88, 89, 92, 93, 95, 105,
 106, 111, 113, 130, 131.
 Report of experiments at Sault Ste. Marie, 69, 81, 101,
 107, 108, 110, 115, 117, 120, 121, 126, 135.
- Haanel-Heroult, electric furnace, 28, 115-117.
- Halcomb Steel Company, Syracuse, Heroult steel furnace, 90.
- Hall aluminium process and furnace, 6, 187.
- Hallstahammar, electric zinc smelting at, 160.
- Harbord, F. W., electric furnace steel, 89, 95.
 "The Metallurgy of Steel," 139.
- Harker, J. A., electrical tube furnace, 23.
 melting temperatures of metals, 40.
 thermo-electric pyrometry, 82.
- Harmet, electric furnace for iron ores, 13, 27, 72, 113-115.
- Heat, balance sheets, 46.
 calories, 38, 46.
 cost, 13, 33, 34, 36, 37, 47, 90, 96, 121, 189-194.
 efficiency, 33, 47, 123-128, 192.
 from burning fuel, (calorific powers), 33, 36, 39, 41-44.
 from electric current, 2, 6, 15, 16, 33, 43, 46, 189-194.
 from silicon, 172.
 insulation, 56.
 losses of, 35, 36, 37.
 meaning of, 37.
 production of in electric furnace, 48, 60-66.
 specific heat of water, 38.
 to melt metals, 40.
 units, 38, 39.
- Heroult, Paul T., aluminium furnace, 6.
 electric steel furnaces, 12, 13, 20, 44-47, 59, 62, 66,
 68, 69, 71, 80, 81, 86-92, 94, 95, 101, 106, 107, 171.
 electric ore-smelting furnaces, 13, 14, 28, 49, 53, 62,
 63, 64, 66, 67, 70, 78, 81, 107, 108-111, 112, 113,
 126, 128, 129, 133, 137, 169.
- Heroult-Haanel, electric furnace, 28, 115-117.

H.

- Heroult-Turnbull, electric furnace, 117-121, 127.
 Higgins, A. C., electric furnace, 173.
 Hofman, H. O., melting temperatures of clays, 49, Seger cones, 82.
 Horse-power used in electric furnaces, 12, 33, 34, 36, 43, (see also electric power used in furnaces).
 Howe, Prof. H. M., electrical crucible furnace, 22.
 melting temperatures of cast-iron, 40
 Hunt, Dr. T. Sterry, Cowles' electric furnace, 6.
 Huntingdon and Siemens, electric furnace, 1, 5.
 Hutton, Dr. R. S., cost of water-power, 34.
 electrical tube furnace, 23.
 ferro-alloys, 138, 140.
 Girod steel furnace, 106.
 heat insulation, 56.
 Hydrogen, calorific power of, 43.
 Hydrolith, 184.

I

- Ibbotson, E. C., Kjellin steel furnace, 95.
 Ideal electric furnace, 48, 122-128.
 Imray, O., electric furnace graphite, 144.
 Independent arc furnaces, 19, 32, (see Birkeland and Eyde, Laval, Moissan, Siemens, Stassano).
 Inductance, 17, 101, 103.
 Induction furnaces, 29, 30, 80, 93-105, 166-167, (see Colby, Gronwall, Kjellin, Snyder).
 Inertia electrical, 17.
 Insulation, electrical, 120.
 of heat, 56, 57, 58.
 Intermittent electric furnaces, 10, 17, 48, (see also Acheson, Borchers, Colby, Cowles, Gin, Gronwall, Johnson, Kjellin, etc).
 International Acheson Graphite Company, 77, 144, 146, 148.
 International Calcium Company, Switzerland, induction steel furnaces, 99.
 Iron, alloys, 12, 136-142.
 blast-furnace, 13, 85, 107, 110, 111, 112, 121, 128, 129.
 casing of electric furnaces, 59, 87, 94, 103, 108, 109, 113, 115, 120, 129, 161, 169.
 cast, 40, 85.
 cost of, 121.
 pig, 49, 85, 86, 107-129.
 reduction from ore, 49, 86, 107-135.
 smelting, electric, 13, 14, 107-129, (see Girod, Haanel, Harmet, Heroult, Keller, Turnbull).
 volatilized, 12.
 wrought, 40, 85.
 Ischewsky, B. Von, rotary electric furnace, 23.
 Italy, electric zinc smelting, 170.
 Stassano steel furnace, 13, 130.

J.

- Jacobs, C. B., production of alundum in electric furnace, 173.
 Johnson, W. McA., electric zinc furnace, 26, 157-158.
 uses of Acheson graphite, 148
 Joule, 3.
 Judd, E. K., graphite, 142.

K

- Kaolin, 49.
 Kathode (or cathode), 2, 174-187.
 Keller, electric smelting of iron, steel, and ferro-alloys, 12, 129, 135, 137.
 electric steel furnaces, 92, 107, 135.
 ore-smelting furnace, 13, 14, 63, 64, 69, 70, 71, 78, 80, 111, 113.
 Kelvin, Lord, energy from the ether, 194.
 Kilogram calorie, 38-39.
 Kjellin, induction steel furnace, 12, 13, 30, 32, 64, 66, 72, 78, 80, 86,
 93-96, 97, 98, 99, 101, 105, 106, 107.
 Kortfors, Heroult steel furnace at, 69, 88.
 Krupp works, Essen, electric steel furnaces, 99, 106.
 Kryptol, 23, 149.

L

- Lake Superior Power Company, 111.
 Lampen, A., high temperature measurements, 50, 51, 55, 56, 83, 153.
 Lanyon Zinc Company, 157.
 La Praz, Heroult steel furnace, 45, 62, 69, 88.
 Lathe, F. E., steel from ore in electric furnaces, 133.
 Laval De, electric furnaces, 28, 29, 59, 72, 80, 135, 158, 159.
 Lead, 40, 161-170.
 Le Chatelier, high temperature measurements, 53, 82.
 Le Leux Keller and Co., electric smelting, 113.
 Lenher, V., H. Moissan, "The electric furnace," trans. by, 7.
 Lewes, F. B., "Acetylene," 155.
 Light electric, 1, 2.
 Lime, refractory material, 50-51, 55, 56, 57, 60, 61.
 Limestone, refractory material, 8, 61.
 Lincoln, P. M., resistivity of carbon, 77.
 Lindblad, electric induction furnace, 101.
 Linings of furnaces, 8, 12, 23, 45, 53, 49-60, 96, 112, 113, 132, (see also individual furnaces).
 Livet, France, Keller ore-smelting furnace at, 70, 113, 137.
 Lloyd, M. B., and Dupre, explosive gas from ferro-silicon, 141.
 Longmuir, P., analysis of ferro-alloys, 139.
 Lotka, A. J., nitrates from air, 173.
 Lucke, Prof. C. E., cost of water-power, 34.
 Lummer, temperature of arc, 53.

M

- Mabery, Prof. C. F., Cowles' furnace, 6.
 reduction of metals by carbon, 9.
 Maeulen-Wilson Company, articles of fused quartz, 172.
 Magnesia (magnesite) refractory material, 8, 19, 51, 52, 55, 56, 57,
 88, 94, 105, 112, 113, 117, 129, 131.
 Magnesium, 184.
 Manganese, 12, 136-141.
 Materials of construction of furnaces, 49-60, (see also alumina, bauxite,
 carbon, carborundum, dolomite, fire-clay, lime, magnesia,
 silica, siloxicon).
 McGill University, electric crucible furnace at, 22.
 Measurements of furnace temperatures, 82, 83.
 Measuring instruments, electrical, 18.
 Melted metals as resistors, 29-30, 72, 93-106.
 Melting contents of furnaces, 26-28, 32, 66, 69.

M.

- Melting metals, furnaces for, 22, (see Colby, Gin, Girod, Harker, Heroult, Howe, Kjellin, McGill, Moissan, Siemens).
- Melting metals, 3, 34, 35, 36, 39, 40, 41, 44-47.
- Melting temperatures of metals, 40, 56.
refractory materials, 49-56.
- Metals, melting temperatures and heat required to melt, 40.
- Metallurgical calorific power, 42-43.
- Methane (marsh gas), CH_4 , 43.
- Miscellaneous uses of electric furnaces, 171-174.
- Missouri, fire-clay, 49.
- Moissan Henri, electric arc furnace, 8, 9, 19, 48, 60, 61, 62, 66, 67, 68, 69, 80.
production of diamond, 3, 7, 9.
researches, 7, 9, 56, 155.
"The electric furnace," 7, 50, 61.
- Moldenke, R., use of electric furnace in foundry, 194.
- Molybdenum, 138, 140, 141.
- Mortar for fire-bricks, 50, 51.
- Multiple core furnace, 153-154.

N.

- Napier, electric arc furnace, 3.
- National Carbon Company, experiments on the resistivity of carbon, 77.
- Natural gas, 43.
- New Jersey fire-bricks, 49.
- Niagara Falls, cost of electric power at, 34.
electric furnace operations at, 12, 54, 138, 146, 173, 179, 181.
- Nickel, 12, 138, 141.
- Nitrates and nitric acid from the air, 173-174.
- Norton Company, manufacture of alundum, 173.
- Norway, cost of water-power in, 34, 174.
electric zinc smelting in, 160.
manufacture of nitric acid from the air in, 174.
- Notodden, manufacture of nitric acid from the air at, 174.

O

- Ohms, 16, 17, 66, 73, 75, 76, 77, 78.
- Oil (fuel), 43.
- Ontario, electric iron-smelting in, 110, 120.
- Open-hearth furnace, 2, 34, 35, 36, 46, 86, 87, 88, 90, 92, 132, 135, steel, 12, 86, 91, 92.
- Operation of electric furnaces, 48-84, (and see individual furnaces).
Heroult steel furnace, 89.
- Optical pyrometry, 82-83.
- Ores, aluminium, 6, 7, 52, 186-187.
iron, 13, 14, 45, 85-135, 147, 191.
zinc, 155-170.
- Ore-smelting, (see aluminium, iron, zinc, etc.).
furnaces, see Conley, Cowles, Evans, Girod, Haanel, Harmet, Heroult, Higgins, Ischewsky, Jacobs, Johnson, Keller, Pichou, Reynolds, Snyder, Stansfield, Stassano, Tone, Turnbull, Willson.

O

- Origin of electric furnaces, 1.
 Output of electric furnaces, 1, 49.
 aluminium, 7, 188.
 calcium carbide, 10.
 carborundum, 150, 153.
 ferro-alloys, 137, 138.
 graphite, 143, 147.
 iron, 110, 120, 121.
 nitric acid, 174.
 sodium, 181.
 steel, 47, 98, 99, 100.
- Oven, coke, 43.

P

- Patterson, W. H., and Hutton, electric tube furnace, 23.
 Peat, fuel, 43.
 Pepys, W. H., electrical heating of iron wire, 3.
 Phosphorus, in electrical furnaces, 174.
 in iron and steel, 88, 132-135.
 Pichou, electric arc furnace, 3.
 Pig iron, 85, 86, 107-120.
 Pittsburgh Reduction Company, aluminium furnace, 187.
 Platinum, melted in electric furnace, 1, 5.
 wire furnace, 21-23.
 Plattenberg works, Westphalia, Gin furnace at, 106.
 Poldihutte Company, Austria, induction steel furnace, 99.
 Porcelain, 21.
 Port Arthur, iron ores from, 121.
 Potassium, 184, 193.
 Potter, Dr. H. N., electric tube furnace, 23.
 heat of oxidation of silicon, 171.
 Pound calorie, 38, 39, 40, 41, 43.
 Power, electric, used in electric furnaces, (see electric power used in furnaces).
 cost of, (see cost of fuel and electrical power).
 Power factor of furnaces, 66, 97, 98, 101-103.
 Pressure furnaces, 193.
 Price, E. F., use of ferro-silicon, 142.
 Processes, (see the subject or the inventor).
 Producer, gas, 43.
 Production of heat in electric furnaces, 48, 60-66.
 coal, 190.
 Pyne, F. R., Melting temperature of cryolite, 187.
 Pyrometry, 53, 56, 82, 83.

Q

- Quartz, fused, 22, 172.
 Quebec, Canada, Charcoal for electric iron smelting in, 110.

R

- Reduction of metals, 9, 191, 192, 193, (see also aluminium, iron and zinc).
 Regulation of electric furnaces and regulating devices, 18, 71-73, 88, 89, 109, 113.

R.

- Refining of steel in electric furnace, 46, 47, 86-94, 132-135.
- Refractory materials, 17, 49-58.
 alumina, 52, 55, 56, 57.
 bauxite, 52, 55, 56.
 carbon, 8, 53, 55, 108.
 carborundum, 11, 54, 55, 56, 153.
 carborundum-fire-sand, 54, 55, 56, 57, 152.
 dolomite, 52, 87, 94, 113.
 expansion and contraction of, 50, 51.
 fire-clay, 49-50, 54, 55, 57, 98.
 graphite, 53, 54, 98, 142, 143.
 heat conductivities, 56-58.
 lime, 50-51, 55, 56, 57, 60, 61.
 limestone, 8, 61.
 magnesia, 8, 19, 51, 52, 55, 56, 57, 88, 94, 105,
 112, 113, 117, 129, 131.
 melting temperatures of, 49-56.
 porcelain, 21.
 silica, 50, 55, 56, 57, 171, 172.
 siloxicon, 54, 55, 56.
- Remscheid, Heroult electric steel plant at, 91.
- Report of European Commission, (see Haanel).
 experiments at Sault Ste. Marie, (see Haanel).
- Resistance electrical, 2, 15, 16.
 furnaces, 3, 16, 21-32, 75-78, (see also individual furnaces).
 pyrometry, 82.
- Resisting contents of furnaces, solid, 26, 32.
 liquid, 28-32, 72, 78.
 melting, 26-28, 32, 66, 69.
- Resistivity, electrical, 75.
 amorphous carbon, 77, 78.
 coke, 76.
 furnace cores, 24, 75-78, 144-152.
 graphite, 77, 78.
 molten metals 72, 78, 101, 105.
 slags, 74, 78.
- Resistors of electric furnaces, 6, 16, 18, 21-26, 32, 73-78.
- Reverberatory furnace, 34-35.
- Reynolds, L. B., electric zinc furnace, 164.
- Richards, Prof. J. W., 39, 78, 92, 144, 147, 150, 153, 180, 194.
 aluminium, 6, 187, 188.
 furnace efficiencies, 36, 37, 156.
 metallurgical calculations, 34, 37, 40, 42, 43, 52,
 53, 56, 58, 125.
- Ries, H., New Jersey, fire-bricks, 49.
- Roberts-Austen, Sir W. C., thermo-electric pyrometry, 82.
- Rods, carbon, 2, 24, 144, 146, 149, 152, 153.
- Roechling, iron works, electric steel furnaces at, 99, 106.
- Rossi Auguste, J., ferro-titanium, 137, 138.
- Ruthenburg, electric furnace, 65, 145.

S

- Salgues, electric zinc furnace and smelting, 28, 160, 161, 162, 170
- Salt, electrolysis of, 170-179, 182-183.
- San Francisco, price of pig iron in, 121.

S.

- Sarpsborg, Norway, electric zinc-smelting at, 160.
- Sault Ste. Marie, electric iron-smelting at, 49, 62, 69, 81, 108, 111, 113, 117, 121, 126, 133.
- Scott, E. K., refractory materials, 52, 54.
- Seger cones, pyrometer, 82.
- Sexton, A. H., refractory materials, 49, 50, 51, 52.
- Shaft furnaces, 34-35, (see also Conley, Haanel, Harmet, Heroult, Keller, Stansfield, Tone, Turnbull).
- Sheffield, induction steel furnaces in, 99.
- Siemens, Sir W., electric arc furnace, 1, 3, 4, 5, 7, 18, 19, 20, 60, 137-
open-hearth, steel, 86.
- Silica (refractory material), 50, 55-56, 57, 171, 172.
- Silicon, 12, 136-142, 150, 171-172.
- Siloxicon, furnace and manufacture, 12, 153-154, (see Acheson).
uses of, 54, 55, 56.
- Silver from clay, 186.
- Smelting and refining, electric, (see Borchers).
- Smelting, electric, cost, 73, 92, 128.
iron and steel, 12.
iron ores, 13, 14, 107-129, (see iron).
regulation of, 18, 71-73, 109, 113.
- Smelting furnace, electric, for ores, Conley, Evans, Girod, Haanel, Harmet, Heroult, Higgins, Ischewsky, Jacobs, Johnson, Keller, Pichou, Reynolds, Snyder, Stansfield, Stassano, Tone, Turnbull, Willson.
- Snyder, induction smelting furnace, 29, 135, 166, 167.
electric zinc smelting, 165, 167, 168, 170.
- Soda (caustic), Acker process, 177-179.
- Sodium, Ashcroft process, 181-183.
Castner process, 179-181.
- Sodium chloride, electrolysis of, 177-179, 181-183.
- Source of electric current, 18.
- Spain, induction steel furnace in, 99.
- Spiegel, 139.
- Stalhane, O., induction steel furnace, 101.
- Stansfield, Dr. A., electric crucible furnace, 22.
electric zinc furnace, 164.
electro-thermic production of iron and steel, 36, 133.
Ideal electric furnace, 121-128.
melting temperature of silica, 50.
thermo-electric pyrometry, 82.
- Stassano, Capt., electric steel furnace, 13, 19, 48, 61, 62, 66, 68, 69, 107, 129-131, 133, 135.
- Steel, 85.
Bessemer, 11, 12, 85, 86.
cost of, 90, 135.
crucible, 36, 85, 86, 88, 89, 91.
melted in electric furnace, 1, 5, 86-107.
open-hearth, 12, 86, 91.
production direct from ore in electric furnace, 129-135.
production of, in electric furnace, 3, 12, 13, 44-47, 86-107, 120-135, (see also Colby, Evans, Gin, Girod, Gronwall, Heroult, Keller, Kjellin, Pepys, Stassano).
structural, 90, 100, 107, 131.
tool, 40, 47, 89, 91, 107.

S

- Steinhart, O. J., ferro-alloys, 138.
 Strontium, 193.
 Sulphur in blast-furnace pig-iron, 132.
 electric-furnace pig-iron, 110, 111, 128, 132.
 electric-furnace steel, 88, 99, 132, 135.
 Sweden, electric zinc-smelting in, 160.
 electric steel-making, 12, 36, 93, 94, 101.
 Syracuse, Heroult steel-furnace in, 90.

T

- Temperature, aluminium furnace, 7.
 definition, 37, 38.
 high of electric furnaces, 2, 3, 7, 15, 24, 33, 55, 143, 144,
 147, 150, 152, 153, 155, 156, 171, 186, 191.
 measurements of, 82-83.
 of arc, 2, 53, 56.
 of electric furnaces, 12, 48, 49, 56, 77, 82-83, 187, 191-
 193, (see also temperatures, high, etc.).
 of melting metals, 40.
 of melting platinum, 2, 21, 50.
 of melting quartz, 2, 50, 55, 56.
 of melting refractory materials, 49-56.
 Thermit, 141, 172, 186.
 Thermo-electric pyrometry, 82-83.
 Thompson, S. P., "Electricity and Magnetism," 1.
 Thomson, 3.
 Thomson, electric welding, 26.
 Tides, electric power from, 194.
 Tilting furnaces, 87-88, 96-98, (see also Colby, Heroult, Wellman)
 Tin, 40.
 Titanium, 12, 132, 136-141.
 Tone, F. J., electric furnaces, 25, 171.
 Tool-steel, 40, 47, 89, 91, 107.
 Transformer, electric, 18, 67, 93, 94, 97, 101, 102, 103, 105, 108, 117,
 119.
 Trollhattan, electric zinc-smelting at, 160.
 Tube-furnaces, 3, 21-23, (see also Despretz, Harker, Hutton, Potter,
 Tucker).
 Tucker, S. A., electric tube furnace, 23.
 high temperature measurements, 55, 56, 83, 153.
 Tungsten, 136-141.
 Turin, Stassano furnace at, 140.
 Turnbull-Heroult, electric ore-smelting furnace, 117-121.

U

- United States, output of aluminium in, 7.
 production of electric steel in, 36, 97, 98.
 production of graphite in, 143.
 Uses of electric furnace, 86, 136-188, 191-194.

V

- Vacuum electric furnace, 83, 193.
 Vanadium, 138, 140, 141.
 Vancouver, electric zinc smelting at, 170.

V

- Vapour of carbon, 2.
 Vaporized substances, in electric furnace, 2, 5, 8, 12, 147, 157-170, 192.
 Vickers, Sons' and Maxim, electric steel furnace, 99.
 Violle, temperature of electric arc, 53.
 Volta, discovery of electric battery, 1.
 Voltage, of arc, 67.
 arc furnaces, 67-69.
 electric furnaces, 66-71, (see also individual furnaces).
 electric supply, 18.
 resistance furnaces, 69-71, (see also individual furnaces).
 smelting furnaces, 69-71, (see also individual furnaces).
 Voltmeter, 16.
 Volts, 16.

W

- Waidner, C. L., methods of pyrometry, 82, 83.
 Waldo, Dr. Leonard, production of electric furnace steel, 96.
 Walls of electric furnace, 21, (see also individual furnaces).
 Wanner, optical pyrometer, 83.
 Water-cooling, electrodes, 4, 5, 59, 60, 80, 81, 87, 105, 130, 173.
 furnaces, 29, 57, 58-60, 94, 97, 161, 167.
 Water-gas, 43.
 Water-powers, 14, 189, 190, 191.
 Watts, 48, 60-66, 73, (see individual furnaces).
 Waves, electric power from, 194.
 Webber, R. F., melting temperatures of fire-clays, 49.
 Weckbecker, J., electric-furnace graphite from charcoal, 144.
 Welland, Ontario, electric iron-smelting at, 14, 107, 120.
 Wellman, tilting open-hearth furnace, 69, 86, 90.
 Westphalia, Gin steel furnace in, 106.
 Wheeler, H. A., melting temperatures of fire-clays, 49.
 White-coal, 189.
 Wilbur mine, electric smelting of ore from, 126.
 Willson Aluminium Company, production of ferro-chromium, 138.
 Willson, T. L., calcium carbide furnace, 9-10, 20, 53, 59, 155.
 Wilson-Maeulen Company, articles of electro-quartz, 172.
 Wood, (fuel), 43.
 Wright, J., "Electric furnaces and their industrial applications," 15,
 25, 53, 173, 174.
 Wrought-iron, 40, 85.

Z

- Zinc, 40.
 electric furnaces, 30-31, 155-170, (see Cowles, Johnson, Laval,
 Reynolds, Salgues, Stansfield, Snyder.
 electro-thermic production of, 155-170.
 Extraction Company, American, 165.







YC 19533

THE UNIVERSITY OF CALIFORNIA LIBRARY

