

ELECTRICITY IN MINING

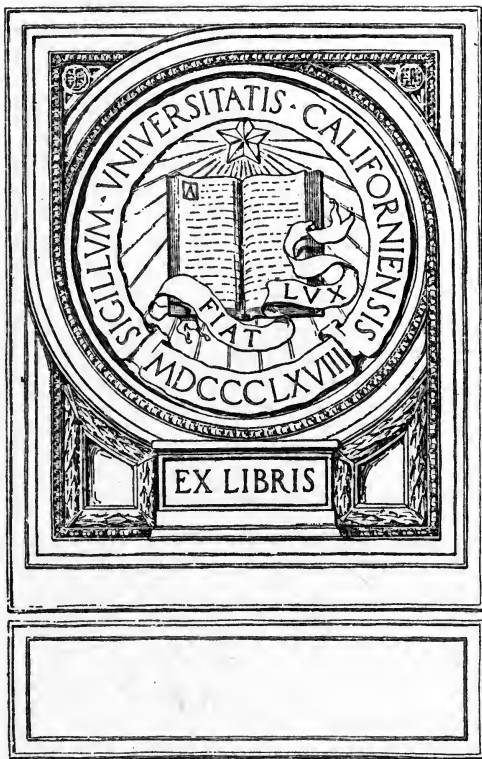

EX LIBRIS

The D. Van Nostrand Company
intend this book to be sold to the Public
at the advertised price, and supply it to
the Trade on terms which will not allow
of reduction.

ELECTRICITY IN MINING

Day of
California

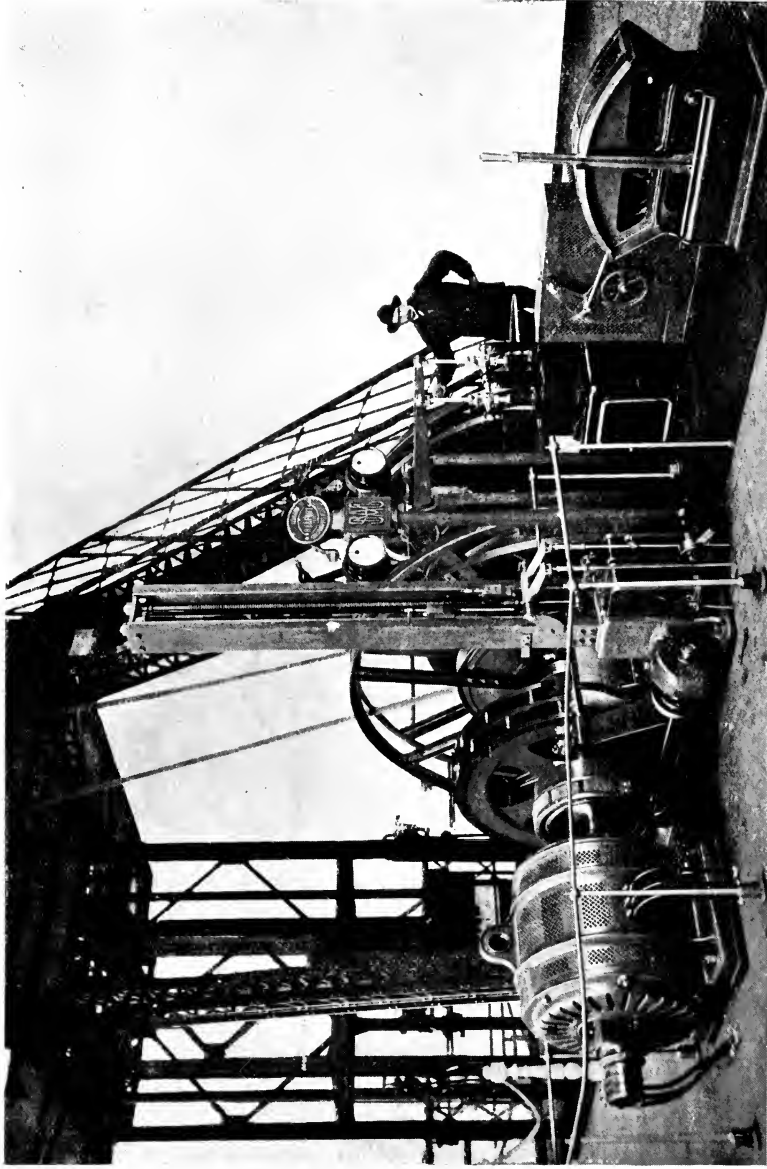

Electrical Winding Apparatus, at the Lens Coal Mines, consisting of a Three Phase Motor, shown on the Left, directly connected to the Winding Drum, Speed being controlled by the Controller shown on the Right, by the Aid of Metallic Resistances connected to the Slip Rings of the Motor. The Cables leading from the Slip Rings are seen on the Left. A Brake Wheel is fixed on the Driving Shaft, between the Motor and Winding Drum, the Brakes being pulled off by Solenoids, when the Wind commences. This Illustration is reproduced by permission of the Editor of *L'Éclairage Electrique*.

ELECTRICITY IN MINING

BY

SYDNEY F. WALKER

M.I.E.E., M.I.Min.E., Assoc.M.I.C.E., &c.



CALIFORNIA

NEW YORK
D. VAN NOSTRAND COMPANY
23 MURRAY AND 27 WARREN STREETS

1907

T 11243
112-

TO MIBU
AMBROGLAD

PREFACE

THE Author has been engaged during the last thirty years in the practical application of electricity to mining work. For a long period he was the apostle of electricity to the mining world, preaching the advantages of electricity for mining, in season and out of season. For a large portion of the thirty years, he conducted a very uphill battle against the natural conservatism of mining engineers and mine managers, who have to think before all things of getting their mineral out, and who could not afford to instal new apparatus, however good it might seem, unless they were quite sure that it would not interfere, even temporarily, with the output; and against the many difficulties inherent in the development of a new industry. He claims to have had a very large share in making the position held by electricity in mining work at the present time; and in the following pages he has endeavoured to give mining engineers, mine managers, and all who are interested in mining work, or who have to do with mines, the full benefit of the experience acquired, often very painfully, during the last thirty years. He has also endeavoured to give as full particulars, and to explain the working as fully as possible, of the very latest up-to-date apparatus employed both in this country, in America, and on the Continent.

In Chapter I. he has given the usual *résumé*, made as full as possible, and to meet the greater knowledge of the subject possessed at the present day by mining engineers, than was possessed thirty years ago, of the underlying principles of electricity, with the terms, etc., in general use. In Chapters II. and III. he has given short descriptions of signals, telephones, and electric-lighting apparatus in use about mines, that in his opinion can be employed with advantage. In Chapter IV. he has gone very fully indeed into the question of the generation of electricity economically. It has appeared to him that if electricity is to be, as he believes it must be,

the agent employed about mines for distributing energy, it is absolutely necessary that the electricity itself should be generated in the most economical way possible, and he has therefore discussed every possible source of power that may be available, and every possible source of economy.

In Chapter V. he has discussed the principles and practice of the distribution of electricity, as it is applicable to mining work, giving descriptions of every method of distribution, even some of those that in his opinion will not often be applied, because it has come to his knowledge that they have been applied in a few cases.

In Chapter VI. he has dealt very fully with the application of electricity to the different machinery about a mine. In writing this chapter, the Author has had before his mind the fact that there are a large and increasing number of engineers who are engaged in the application of electricity to mining work, and who necessarily are not familiar with the working of mines, when they first come to them. In the past there have been a very large number of failures, and a very large amount of money wasted, owing to the fact that those who have been engaged in applying electricity to some mining problem, have not been acquainted with mines, and have been far too sanguine as to the amount of power required for performing a given amount of work. Pathetic complaints have been made at the Mining Institute, by those who have been advising mining engineers in the application of electricity, that motors supposed to deliver a great many horse-power would not perform the work, say in hauling trams, that was easily performed by one horse in the flesh. It has been the Author's endeavour, in writing Chapter VI., to provide information that will enable whoever may be engaged in mining work, to form a very safe idea of the power he must provide in each case, while on the other hand he has endeavoured to show mining engineers and mine managers how that power is to be delivered, and how they are to know when they have the proper amount.

In Chapter VII. the Author has given a few simple rules for the discovery of "Faults," or causes of failure. In this chapter also he has had in his mind the man engaged about a mine, and not a man who is accustomed to the use of delicate laboratory instruments, and who has a well-constructed laboratory, with solid foundations for his instruments, to make his tests in. He has endeavoured to give a few simple rules that can be applied by any engineer who has acquired a

certain knowledge of electricity, with apparatus that can be employed in any mine in any part of the world. He has in view the possibility that a mine may be situated hundreds of miles from everywhere, and that the engineer in charge of the apparatus may have only himself to depend upon, may be obliged to depend upon rough and ready apparatus, but will be obliged to keep things going.

The Author hopes that the book will be of use to mining engineers, mine managers, and every one employed about a mine in every capacity.

SYDNEY F. WALKER.

1, BLOOMFIELD CRESCENT, BATH,

January 18, 1907.

CONTENTS

CHAPTER I

DEFINITIONS, UNITS, ETC.

	PAGE
What Electricity is	1
Electrical Pressure and Electrical Current	4
The Volt, the Ohm, and the Ampère	5
The Electric Circuit	6
Work done in Electric Circuits	8
Heating Effect of Electric Currents	9
Methods of producing Electrical Pressure	10
Magnetism and the Magnetic Circuit	11
Difference between Alternating and Continuous Currents	14
Two-phase and Three-phase Currents	16
Electrostatic Induction and the Capacity of Cables	17
Electro-magnetic Induction	19
Electrolysis	20

CHAPTER II

ELECTRIC MINING SIGNALS AND TELEPHONES

Electric Mining Signals	22
Sources of Current for Mining Signals	27
Forms of Galvanic Battery	28
Shaft Signals	33
Bells for Mining Signals	35
Relays for Mining Signals	36
Telephones for Mines	37
Telephonic Communication on Engine Roads	39
Wireless Telegraphy for Mines	40
Shot Firing by Electricity	41
Frictional Electrical Firing Apparatus	43

CHAPTER III

ELECTRIC LIGHTING FOR MINES

Arc Lamps	45
The Mechanism of Arc Lamps	47
Alternating-current Arc Lamps	54

	PAGE
Flame Arc Lamps	54
Difference in the Working of Continuous and Alternating Current Arc Lamps .	61
Supporting Arc Lamps	65
Incandescent Lamps	68
The Gem Carbon Filament Incandescent Lamp	70
Metallic Filament Lamps	70
High C.P. Incandescent Lamps	71
The Nernst Lamp	76
Delivering the Current to Incandescent and Nernst Lamps	79
Portable Electric Lamps	80

CHAPTER IV

THE GENERATION OF ELECTRICITY

The Electricity Generating Station	83
The Possibility of using Water Power	83
How the Water Power is measured	85
Forms of Water Engines	86
Short Description of Pelton Wheel	88
Steam Plant	88
Forms of Water-tube Boilers	91
What Combustion is	98
The British Thermal Unit	99
Apparatus for Economizing in Coal and Labour	108
Natural, Induced, and Forced Draught	104
Methods of Burning Low-grade Fuel	106
The Boiler-feed Problem	108
Injectors	112
Economizers	113
Feed-water Heaters	114
Water Softeners	116
Grease Extractors	117
Coal Conveyers	118
Reciprocating Steam Engines	119
Working Steam Engines Expansively	120
The Government of Steam Engines	126
Difficulties in the Way of working Expansively	126
Overcoming Condensation Troubles	128
Superheating	129
Condensers	134
Forms of Condenser	135
Steam Turbines	141
The Willans-Parsons Steam Turbine	142
The De Laval Turbine	143
The Curtis Turbine	144
The Westinghouse Turbine	145
Turbines using Exhaust Steam	145
Steam Turbines and Condensing	146
Cooling Towers and Ponds	146
Forms of Cooling Towers	149
Gas and Oil Power. Producer and Kindred Gas	152
Producer Gas	153
The Suction Gas Producer	154
The Internal Combustion Engine	157
Governing the Internal Combustion Engine	159
Cooling the Engine Cylinder	160

CONTENTS

xi

	PAGE
Gas Engines for Large Powers	161
Oil Engines	163
Governing the Oil Engine	165
The Ignition Problem	165
The Diesel Engine	166
A Coal-dust Burning Engine on Similar Lines to the Diesel	168
Generators of Electricity	169
The Armature	170
The Commutator	174
The Excitation of Continuous-current Machines	175
The Alternating Current Generator	185
Single, Two, and Three Phase Alternators	189
The Output and Number of Poles of Single, Two, and Three Phase Alternators	191
The Inductor Alternator	192
Secondary Batteries or Accumulators	193
Boosters	196
Motor Generators	198
Balancers	200
Continuous-current Machines with Two Armature Windings	200
Stationary Transformers	200
Transformers for Single, Two, and Three Phase Currents	205
Cooling Stationary Transformers	205
Arrangement of Apparatus in the Generating Station	206
The Size of the Units	207

CHAPTER V

DISTRIBUTION OF POWER BY ELECTRICITY

Distribution of Power by Electricity	209
Conductors for Electric Light and Power Distribution	211
Overhead Conductors	212
Insulated Conductors	215
Bitument-covered Cables	218
Paper and Yarn-covered Cables	219
Fire-proof Covering for Cables	220
The Formation of Stranded Conductors	221
Concentric Cables	221
Three-core Cables	224
Sizes of Cables for Lighting and Power	224
Heating of Cables	226
Wires and Cables for Connecting to Lamps, etc.	228
Cables for Coal-cutting Machines and Moving Motors	229
Fixing Cables in Mines	229
Fixing Wires on Engine Roads, etc.	234
Methods of Distribution	235
The Two-wire System	236
The Three-wire System	238
The Use of the Accumulator as a Balancer	241
Distribution by Two and Three Phase Currents	241
Distribution by Two and Three Phase Currents at High Tension and at Extra High Tension	243
The Main Switchboard	245
The Parallel or Bus Bar System	246
Synchronizing Apparatus	249
Paralleling Compound Continuous-current Machines	250
The Independent System	251
Switchboard Gear for High Tensions and Extra High Tensions	253

	PAGE
Sub-station Switchboards	254
Measuring Instruments for use on Main and Sub-station Switchboards	259
Moving Coil Instruments	260
Gravity Instruments	261
Hot Wire Instruments	261
The Electrostatic Voltmeter	262
Switches, Fuses, and Circuit Breakers	262
Fuses	266
Circuit Breakers	268
Time Limit Circuit Breakers	269
The Ferranti Alternating Current Time Limit Relay for Circuit Breakers	269
Atkinson's Time Limit Circuit Breaker	270

CHAPTER VI

THE APPLICATION OF ELECTRICITY TO DRIVING MACHINES, ETC., IN MINES

The Electric Motor	272
Methods of varying the Speed of Electric Motors	282
The Motor with Commutating Poles	285
Varying the Speed of the Three-phase Motor	286
Electrically driven Pumps	286
Forms of Pumps	287
Ram Pumps	292
The Bucket Pump	296
Power required for driving Pumps	297
Haulage	300
Power required for Endless Rope Haulage	302
Power required for Single Drum Haulage	305
Main and Tail Haulage	306
Power required for Main and Tail Haulage	307
Transmitting the Power from the Electric Motor to the Haulage Gear	308
Overhead Rope Railways	309
Winding by Electricity	309
The Sources of Waste in Winding	310
The Siemens-Ilgner Winding Arrangement	314
Westinghouse System of Electrical Winding	317
Winding in Metalliferous Mines	322
Coal-cutting by Electricity	324
The Process of Holing or Kirving	324
Longwall Coal-cutting Machines	325
Heading Machines	327
The Rotary Heading Machine	328
Motors employed with Coal-cutting Machines	329
Delivering the Current to Coal-cutting Machines	329
Drilling by Electricity	330
Coal Cutting by means of Drilling Machines	335
Electrically driven Fans	336
Description of Different Forms of Fans	336
The Sirocco Fan	338
Power required for driving Fans	340
Driving Air Compressors	341
Power required for driving Air Compressors Underground	345
Electric Locomotives	346
The Electric Driving of other Machinery about the Mines	347
Estimating the Power given out by Steam or Compressed Air Engines that are to be displaced by Electric Motors	348

CHAPTER VII

FAULTS IN ELECTRICAL APPARATUS

	PAGE
Faults in Electrical Apparatus	350
Rules for Testing	351
Faults in Mine Signals	352
Faults in Telephones	355
Faults in Dynamo Machines	357
Faults in Continuous-current Armatures	357
Testing for Disconnection in Continuous-current Armatures	359
Turning up Commutators	360
Testing for Disconnection in an Alternating-current Armature	361
Conductivity and Insulation Tests in Dynamos	362
Testing for Insulation	364
Trouble with the Brush Holders	365
Faults in Cables	366
Finding a Short Circuit between Cables	368
Testing Cables for Disconnection	369
Tests by Electrostatic Capacity	370
Faults in Switch Gear	371
 INDEX	 373

LIST OF ILLUSTRATIONS

FIG.	PAGE
1. Diagram of Series Connections	7
2. Ditto, Parallel Connections	7
3. Ditto, Parallel Series Connections	8
4. Ditto, Two-wire Engine Road Signal, with One Bell	22
5. Ditto, ditto, Two Bells	23
6. Ditto, Three-wire Engine Road Signal, with Two Bells	24
7. Ditto, ditto, with several Bells in Series	25
8. Ditto, ditto, in Parallel	25
9. Reel Insulators for Engine Road Signals	30
10. Vulcanized Rubber Insulators for Engine Road Signals	31
11. Shackle Insulators for Engine Road Signals	31
12. Diagram of Shaft Signals	32
13. Ringing Key for Shaft Signal	33
14. Ditto, ditto, worked by Long Lever	34
15. Sectional Drawing of Ringing Key for Shaft Signal	34
16. Gas Proof Trembler Bell, for Mining Signals	35
17. Ditto, Single Stroke, for Mining Signals	35
18. Diagram of Relay for Engine Road Signals	36
19. Iron-cased Relay for Mining Signals	37
20. Special Telephone Set for Mining Work	40
21, 22. Sections of Johnson and Phillips' Single-carbon, Brake Mechanism Arc Lamp	47
23. Mechanism of Union Co.'s Open Arc Lamp	49
24. Sectional Drawing of "Jandus" Enclosed Arc Lamp	50
25. Ditto, Johnson and Phillips' "Ark" Enclosed Arc Lamp	50
26. Diagram of the B. T. H. Co.'s Enclosed Arc Lamp	51
27. "Angold" Enclosed Arc Lamp, showing Mechanism and Resistance	51
28. Mechanism of Union Co.'s Enclosed Arc Lamp	52
29. Ditto, "Angold" Double Carbon, Open Type Arc Lamp	53
30. Ditto, ditto, ditto, for Rectified Currents	55
31. Sectional Drawings of "Excello" Flame Arc Lamp	56
32. Curves showing Light given by "Excello" and ordinary Arc Lamps	57
33. Sectional Drawings of "Juno" Flame Arc Lamp	58
34. Diagram of Connections for Two and Four Arc Lamps to Service Mains	59
35. Diagram of Arrangement for Working Lamps from a Motor Generator	60
36. Ditto, ditto, for Arc Lamps in Parallel across a 65 or 100 volt service	61
37. Automatic Cutout for Continuous-current Arc Lamp	62
38. Diagram of Alternate-current Arc Lamps, in Series, with Balancing Coils	63
39. Diagram of Connections for Two Arcs with Compensator on an Alternate- current Service	64
40. "Economy" Coil, or Compensator	64
41. Lattice-work Iron Lamp Post for Arc Lamp	66
42, 43. Sectional Drawings of Schaeffer's Suspension Apparatus for Arc Lamps	67
44. Parts of Incandescent Lamp Holder	73

FIG.	PAGE
45. Forms of Incandescent Lamp Holders	74
46, 47, 48. "Glower" and Compensating Resistance of Nernst Lamp	76
49, 50. Complete Nernst Lamps, with Shades, etc.	77
51. Diagram of Connections of Nernst Lamp	78
52. Curves showing Light given by Nernst Lamp	79
53. Sectional Drawings of Davy Paxman's "Economic" Boiler	90
54. Ditto, "Stirling" Boiler	93
55. Ditto, "Climax" Boiler	97
56. Sectional Drawing showing Arrangement for Burning Coal-dust in Lancashire Boiler	107
57. Ditto, Worthington Plunger and Ring Pump	110
58. Ditto, Showing Connection of Injector to Lancashire Boiler	112
59. Ditto, Ditto, Water-tube Boiler	113
60. Ditto, Ditto, Feed Water Heater	114
61, 62. Royle's Feed Water Heater	115
63. One Form of Wells' Oil Filter	117
64. Sectional Drawings of Bellis' Compound Engine	123
65. Ditto, Ditto, Triple-expansion Engine	125
66. Tinker's Superheater, fixed in a Lancashire Boiler	130
67. Longitudinal Section of Davy & Paxman's Superheater	131
68. Transverse Section and Diagram of Ditto	132
69. Curves showing the Advantages of Superheating	133
70. Electrically-driven Edwards' Triple Air Pump	134
71. Sectional Drawing of Edwards' Air Pump	135
72. Ledward's Evaporative Condenser	136
73. Sectional Drawing of Worthington Jet Condenser	137
74. Ditto, Ledward's Ejector Condenser	138
75. Sectional Diagram of Worthington Central Condenser	139
76. Ditto, ditto, Central Condensing Station	140
77. Ditto, ditto, Cooling Tower	150
78. Ditto, Campbell's Suction Gas Producer	156
79. Ditto, Oechelhausen Two Cycle Gas Engine	162
80. Sectional Drawings of Diesel Oil Engine	167
81. Commutator of Continuous Current Generator	175
82. Diagram of Connections of Continuous Current Separately Excited Generator	176
83. Ditto, Series-wound Generator	177
84. Ditto, Shunt-wound Generator	178
85. Ditto, ditto, with Adjustable Field Current	179
86. Ditto, Compound-wound Generator	180
87. Messrs. Santoni's Brush Holder	184
88, 89. Diagram of Connections of Two and Three Phase Armatures	190
90. High-tension Insulators	213
91. A Special Form of High-tension Insulator	214
92, 93. Diagrams of Mavor and Coulson's Concentric Cables and Methods of Jointing them	222
94. Diagram showing Method of connecting a Branch to Mavor and Coulson's Concentric Cables	223
95. Messrs. Callender's Single Cable Cleat for Mine Shafts	230
96. Ditto, Two Cable Cleat for Ditto	231
97. Ditto, Single Cable Cleat, supported by Chains	232
98. Messrs. Glover's Method of jointing Cables in a Shaft	233
99. Diagram of Two-wire System of Distribution	237
100. Ditto, Three-wire System, with Two Generators	239
101, 102. Diagrams of Three-wire System, with one Generator	240
103. Ditto, Connections for Three-phase High Tension Distribution	243
104. Ditto, ditto, Three-phase Extra High Tension Distribution	244
105. Ditto, ditto, Two Shunt-wound Generators to Bus Bars	247
106. Ditto, ditto, Two Separately Excited Machines to Bus Bars	247
107. Ditto, ditto, Three-phase Generators to Bus Bars	248

LIST OF ILLUSTRATIONS

xvii

FIG.	PAGE
108. Diagram of Connections of Two Compound Machines to Bus Bars . . .	250
109. Ditto, ditto, a Sub-station at a Colliery, to take Current from a Power Service . . .	255
110. Sectional Diagram of the Back of the Switchboard shown in previous Figure . . .	256
111, 112. Diagrams of Berry, Skinner and Co.'s Distributing Boards . . .	257
113. Sectional Diagram of Mavor and Coulson's Distributing Fuse Box . . .	258
114. Double-pole Switch in Iron Case . . .	264
115. Iron-cased Fuses for Mining Work . . .	268
116. Diagram of Connections for Starting a Series-wound Motor . . .	273
117. Ditto, ditto, ditto, a Shunt-wound Motor . . .	273
118. Ditto, ditto, Johnson and Phillips' Motor Starting Box . . .	274
119, 120. Ditto, ditto, the B. T. H. Co.'s Form A Starting Box . . .	276
121, 122. Ditto, ditto, ditto, Form B . . .	277
123. Sectional Drawing of Messrs. Reyrolle's Packing Ring for Gas-tight Motor Starters . . .	278
124. Diagram of Connections for Starting Three-phase Motors . . .	280
125. Ditto, Westinghouse Three-phase Motor Starting Boxes . . .	281
126. Ditto, Connections for regulating Speed of Series-wound Motor by Variation of Pressure . . .	282
127. Ditto, ditto, for varying Speed of Series-wound Motor by Varying Field Current . . .	284
128. Ditto, ditto, for Varying Speed of Shunt-wound Motor . . .	285
129. Sectional Diagram of Worthington Multistage Centrifugal Pump . . .	289
130. Efficiency Curve of Centrifugal Pump, with Constant Quantity . . .	290
131. Ditto, ditto, with Constant Speed . . .	291
132. Sectional Diagram of Riedler Differential Pump . . .	294
133, 134. Gutermuth Valves . . .	295
135. Sectional Drawing of David Bridge's Friction Clutch . . .	300
136, 137. Friction Clutches, and Arrangement for Endless Rope Driving . . .	301
138. Diagram of Connections of Three-phase Winding Plant at Preussen II. Colliery . . .	311
139. Side Elevation of Electric Winding Plant at Zollern II. Colliery . . .	312
140. Plan of Winding Gear at Zollern II. Colliery . . .	313
141. Diagram of Siemens-Ilgner System of Electric Winding . . .	316
142. Ditto, Westinghouse System of Winding from a Three-phase Supply Service . . .	318
143. Diagram of Westinghouse Converter-Equalizer System . . .	320
144. Diagram of Control Gear of Westinghouse Electric Winding Plant . . .	321
145. Plan of Whiting System of Winding from Deep Metalliferous Mines . . .	323
146. Sectional Drawing showing Operation of Disc Coal-cutting Machine . . .	326
147. Vertical Sectional Drawing of Machine shown in previous Figure . . .	327
148, 149. Sectional Drawings of Siemens' Rotary Electric Drill . . .	331
150. Ditto, ditto, of Siemens' Percussion Drill . . .	332
151, 152. Sectional Drawings of Motor Cases for Siemens' Drills, where the Motors are separate . . .	333
153, 154. Ditto, Denver Electric Air Drill . . .	334
155. Ditto, Marvin Electric Drill . . .	334
156. Diagram showing Relative Efficiencies of Compressed Air when Compressor is driven at Bank and in-Bye . . .	344
157. Lineman's Detector Galvanometer . . .	353
158. Diagram of Connections for testing a Telephone Set . . .	356
159. Ditto, ditto, for a Break in an Armature . . .	359
160. Ditto, ditto, for a Break in a Field Coil . . .	363
161. Ditto, ditto, Insulation Resistance of an Armature . . .	364
162. Ditto, ditto, ditto, Armoured Cable . . .	366
163. Ditto, ditto, ditto, Unarmoured Cable . . .	367

LIST OF PLATES

PLATE	TO FACE PAGE
Electric Winding Plant at Lens Colliery	<i>Frontispiece</i>
1A. Babcock and Wilcox Water-tube Boiler	88
1B. Climax Water-tube Boiler	88
2A, B, and C. Hodgkinson's Mechanical Stoker	104
2D. Carter's Economizer	104
3A. Green's Economizer	112
3B. Royle's Water Softener	112
4A. Bellis' Triple Expansion Engine, with Generator	128
4B. Willans-Parsons' Steam Turbine	128
5. Oechelhausen Gas Engine, driving Dynamo	144
6A. Korting Gas Engine	152
6B. Mather and Platt's Multipolar Dynamo	152
7A. Field Magnet Ring, with Magnets and Brush Holders	160
7B. A Motor Generator	160
8A, B, and C. Dick-Kerr & Co.'s Turbo Alternator	168
9A. A Sub-station of Rotary Convertors	184
9B. A Water-power driven Generating Station	184
10. An Oechelhausen Gas-engine driven Generating Station	192
11. A Suction Gas Producer Generating Station	208
12A and B. Reyrolle's Switchboard	216
13A. A Siemens Switchboard	224
13B. A Westinghouse Sub-station Board, for underground	224
13C. Ferranti Triple-pole Circuit Breaker	224
14A and B. Ferranti Oil Enclosed, 10,000 Volts for Switches	232
14C and D. Ferranti Enclosed Three-phase Mining Switches	232
15A and B. Siemens' Motor Generator Switchboard	240
15C. Dorman and Smith's Gas and Fool Proof Switch	240
16A and B. Westinghouse Distributing Boxes for Mines	248
16C and D. Ferranti Circuit Breakers	248
17A and B. Current and Pressure Transformers for Switchboard Instruments	256
17C. Ferranti Gas-proof Switch	256
17D. Reyrolle's Oil Enclosed Three-phase Switch	256
18A. Handle Fuses	264
18B, C, and D. Ferranti Circuit Breakers	264
19A. Parts of Continuous-current Motor	272
19B, C, and D. Three-phase Motor, and parts of ditto	272
20A and B. Reyrolle's Motor Starting Switch	280
20C. The International Electrical Co. Reversing Apparatus, for Electric Winding, as used at Waihi Junction Mine, New Zealand	280
21A. Dorman and Smith's Liquid Starting Resistance	288
21B. Motor Starting Panel	288
21C. Reyrolle's Enclosed Mining Switch	288
22A and B. Siemens' Motor Switchboard	296
22C. Wound Rotor for Two-phase Motor	296
22D. Diamond Coal Cutting Co.'s Electric Rotary Drill	296

PLATE	TO FACE	PAGE
23A. High Lift Centrifugal Pump, driven by Electric Motor		304
23B. Mather and Platt's Variable Speed Three-throw Ram Pump Electrically Driven		304
24A. Worthington Centrifugal Pump, Electrically Driven, arranged for Sinking		312
24B. Electrically Driven Three-throw Sinking Pump		312
25A. Electrically Driven Centrifugal Pump, suspended over Shaft, ready for Sinking		320
25B. Dick-Kerr & Co.'s Electric Loco, with Bow Trolley.		320
26A. Electrically Driven Three-throw Dip Pump		328
26B. Electric Mine Loco, coming out of a level		328
27A. Electrically Driven Endless Rope Haulage Plant		336
27B. Electrically Driven Dip Haulage Plant		336
27C. Electrically Driven Main and Tail Haulage Plant		336
28A. Electrically Driven Winding Plant		344
28B. Electric Winding Motor and Brake used at Waihi		344
29A. Clarke-Stevenson's Disc Coal-cutting Machine, with Worm Gearing		352
29B. Diamond Coal Cutting Co.'s Disc Machine		352
29C. Pickquick Bar Coal-cutting Machine		352
29D. Electrically Driven Chain Coal-cutting Machine		352
30A. Heenan and Froude's Fan, without case.		360
30B. Heenan and Froude's Fan, in case, electrically driven		360
30C. Fan House, Electrically Driven Fan for Three-phase Service		360
31A and B. Reavell's Electrically Driven Air Compressors		368
31C and D. Blakett's Underground Coal Conveyer, Electrically Driven		368

ELECTRICITY IN MINING

CHAPTER I

DEFINITIONS, UNITS, ETC.

What Electricity is

At the present time there are two theories of electricity, one held by the advanced section of the professors led by Professor J. J. Thompson, of Cambridge, and known as the *corpuscular* or electrotonic theory; and the other held by those practical engineers who have thought about the matter, and, the author believes, by a section of the professors led by Sir Arthur Rucker, the Principal of the London University, known as the wave or molecular theory. In order to understand the corpuscular theory, it is necessary to briefly explain the atomic theory, which those mining engineers who have studied chemistry will already have met with. In the atomic theory there are a certain limited number of substances which are indivisible into other substances, so far as any means at the disposal of the laboratories is able to accomplish at present, these substances being known as the chemical elements. The elements combine with each other to form compounds, the compounds possessing different properties from those of the elements out of which they are formed, and having a different appearance. The elements always combine in certain fixed proportions, these being the atoms. One or more atoms of any element may combine with one or more atoms of other elements to form one or more molecules of a compound. The atom was supposed to be the smallest body that could exist, and it could not exist alone. Two or more atoms of an element might exist together as a molecule of that element. The molecules are supposed to be all the same size, but the atoms are of different weights, and the atomic weight is that quantity by weight of each element that enters into combination with one or more atoms of other elements. In the corpuscular theory, the atom is again supposed to be divided into an enormous number of smaller bodies known as *corpuscles* or

electrons. There are an equal number of positively electrified and negatively electrified corpuscles in every atom in its normal condition. The negatively electrified corpuscles or electrons are supposed to completely surround and enclose the positively electrified electrons. The negative electrons are thrown off from the surface of the atom with great velocity, and when an atom has lost one or more negative electrons, it becomes positively electrified, and exercises an attraction for any body which is short of positive electrons. On this theory an electric current is supposed to be a procession of electrons in the space surrounding the conductor through which a current is supposed to pass. The corpuscular theory has been led up to from the laboratory, and mainly from the researches that have been made on the Crookes' tubes used with X-ray apparatus. The *cathode*, the negative electrode in the Crookes' tube, has been found to give off a large number of negative corpuscles at a very high velocity.

The wave, or molecular, or mechanical theory of electricity has been led up to from the principles that have been gradually evolved—since the wave theory of light enunciated by Dr. Thomas Young took the place of the corpuscular theory of light previously held by Sir Isaac Newton and others. Sir Isaac Newton believed that light came to us from the sun, very much in the same way as the enunciators of the corpuscular theory of electricity believe that electric currents are formed. The wave theory took its place, however, among scientific men, even in Newton's lifetime, for reasons there is not space to detail here. Dr. Young propounded the theory that light comes to us in waves, somewhat similar, but different in form, to the waves that had already been shown to be the method of the propagation of sound, and that we are familiar with in water.

The Ether.—In order that light should come to us in waves, it was necessary that there should be a medium for the passage of the waves, hence the invention of the ether by the scientific men of those days. It is now recognized that our sun, his planets, and the whole of the heavenly bodies float in an elastic fluid, whose properties are not yet fully understood, and which goes by the name of the Ether. White light, as we know, is made up of a number of coloured lights, the beautiful colours of the rainbow or *spectrum*, red being at one end of the spectrum and violet at the other. It is also now known that the different colours are due to differences in the lengths of the waves by which the different colours are transmitted. The length of the wave in the red is approximately $\frac{1}{33,000}$ of an inch, while that of the wave in the violet is about half that length. But it is also well known now that the different colours and the different wave-lengths correspond to different properties; thus, red rays have greater heating property, while violet rays have greater actinic or chemical properties, and the yellow rays, which are near the middle of the

spectrum, have the greatest lighting value. Further, there are dark rays beyond the red, known as the infra red, the wave-length of which is longer than that of the red; and there are also dark rays beyond the violet, known as the ultra violet, which have greater chemical power than the violet rays, and whose wave-length is shorter than the violet. It will be evident that there is a long range of wave-lengths below the infra red and above the ultra violet that have not yet been located, and whose properties are not yet known, but that are being gradually investigated. Further, when an electric current is caused to heat a conductor, if the current is sufficiently powerful, and is allowed to pass for a sufficient length of time, first, invisible heat rays are produced; next, visible red; then yellow; and finally white rays. Hence it was but a natural sequence of the acceptance of the wave theory of light, that the wave or mechanical theory of heat should follow, and then that the wave or mechanical theory of electricity should follow the wave theory of heat. It has also been proved, by the researches of Hertz and others, that electric waves are created, and they are used in wireless apparatus, of which Marconi's is the best known.

The View for the Practical Engineer.—The above has been detailed, though it is not absolutely necessary, because the author believes that the engineer of the present day takes a great and increasing interest in every development of every science that he has to handle, and most engineers have to handle several sciences. The practical engineer has to remember, however, that by the law of the conservation of energy, electricity, no matter what may be its form, is only obtained by transformation from some other form of energy.

The Law of the Conservation of Energy.—In these days when researches upon radium and helium are supposed to have upset some of the laws that were supposed to govern the universe, it is wise for the practical engineer to remember what the law of the conservation of energy is, and to keep close to it. This law states that the quantity of matter and the quantity of energy in the universe are fixed and unchangeable, and that neither matter nor energy can be lost or created. Hence, when we talk of creating or generating, say, electricity, we really mean—we can only mean—that we have transformed energy from some other form into electricity, and that in whatever form electricity is generated, to use the convenient expression, work must have been done, or, as we say, some other form of energy must have been expended.

Electrical Pressure and Electrical Current

The term **pressure** is used by electrical engineers in the same way as it is employed by mechanical and civil engineers. It implies the presence of a force that will give rise to an electrical current when the other electrical conditions are favourable. Put in another way, an electrical current will pass between any two points where there is a sufficient electrical pressure between these two points to overcome the resistance opposed to the passage of the current. Further, the electrical current that will pass between the two points will be directly proportional to the pressure existing between them, and inversely proportional to the resistance opposed to the passage of electricity.

Ohm's Law.—The above law, which governs so much of the action of electric currents, is known by the name of the celebrated German professor who discovered it. It must be understood, however, that the pressure employed in applying Ohm's law is the net pressure present between the two points. It happens in many cases, as in primary and secondary galvanic batteries, and in apparatus where magneto-electric induction takes place, that opposing pressures exist between the two points in question. When this is the case, the pressure to be employed is the algebraical sum of all the pressures existing between the two points. A good illustration of this is where accumulators are being charged. The charging dynamo furnishes a current of a certain pressure; the accumulator, being charged, furnishes an opposing pressure nearly equal to it; and the resultant current, passing through the accumulator, the cables, etc., is found by applying Ohm's law, but using the difference between the charging and opposing pressures as the pressure for calculation.

Ohm's law is written—

$$C = \frac{E}{R}$$

also—

$$E = CR,$$

and—

$$R = \frac{E}{C}.$$

The second and third formulæ will be recognized as merely algebraical transpositions of the first. Also, when E is in volts, and R is in ohms, C is in amperes.

The Volt, the Ohm, and the Ampère

The Volt is the unit of electrical pressure. It is used by electrical engineers in very much the same way as the pound is used by mechanical engineers. It is a definite multiple of the standard electrostatic unit, the force exerted by a body of unit volume, charged to unit electrical potential upon another body similarly charged at unit distance. The practical engineer need not trouble himself very seriously about the standard units. The volt is about equal to two-thirds the pressure that the Leclanché cell, so much employed in electric signals, telephones, etc., should have when giving no current. It is also about equal to two-thirds the pressure of the standard Clark cell that is employed in laboratory work, and in delicate tests of electrical apparatus.

The Ohm is the unit of electrical resistance. All bodies resist the passage of electricity through them, the metals less than other bodies, and silver and copper the least of the metals, while substances such as dry cotton, dry silk, indiarubber, bitumen, porcelain, and others, offer a very high resistance indeed to the passage of electricity. Substances are roughly divided into conductors and insulators, the conductors being mainly the metals, and the insulators the substances mentioned above, and some others. The standard unit of resistance is a column of mercury of certain dimensions kept at Paris. For practical purposes it is perhaps more important to know that 1 mile of No. 4 copper wire, $\frac{1}{2}$ mile of No. 8, and other lengths of other wires have approximately a resistance of one ohm.

Specific Resistance.—What is known as the specific resistance of any substance is the ratio which the resistance offered by a cubic centimeter, or cubic inch of the substance between two opposing faces, bears to that offered by a cubic centimeter or cubic inch of silver. The specific resistance of iron and steel are from six to seven times that of silver and copper. The specific resistance of the insulators are some of them many million times that of silver and copper. The resistance of every body of any substance is proportional, directly to the length of the body in the direction in which the current will pass, and inversely to its sectional area in the same direction. Thus the resistance of a copper conductor, intended to carry a lighting or power current, varies directly as its length, and inversely as its size, while the resistance of the indiarubber or other insulating envelope varies directly as the thickness of the envelope, and inversely as the length of the conductor it envelops. The resistance of all substances also varies with the temperature. The resistance of all the metals increases as the temperature rises, by a definite fraction, that of carbon and some other substances decrease.

The **Ampère** is the unit of current, and it is that which flows through any conductor under a pressure of one volt when opposed by a resistance of one ohm, or any multiples of these numbers. Thus one ampère will pass under a pressure of 100 volts, opposed by a resistance of 100 ohms.

The Electric Circuit

The electric circuit is the path of the current that is intended to perform useful work, and it must include the generator, the apparatus that is to be worked, the apparatus that controls the passage of the current through the circuit, such as the switch or the push, and the wires or cables connecting all together. There may be, and usually are, several circuits having the generator common to all of them, but the same remark applies to each of the branch circuits, as they are termed. The terms **open circuit** and **closed circuit** are expressions meaning that, in the first place, the circuit is not complete, and therefore the apparatus that is to be worked by the passage of a current through it does not work, and in the other case that it is complete, and that the apparatus should work. The term **breaking circuit** is also employed, and means opening the circuit, destroying its continuity, as when a switch is thrown back, or when a wire or cable is parted. Ohm's law applies to the working of all electric circuits, whether single or composed of several branches. The current which passes in any circuit or in any branch circuit is determined by Ohm's law, but in the whole circuit the whole of the resistance, including that of the generator, must be taken into account in calculating the current that will pass, and in any branch circuit the pressure that exists between the ends of each branch and the resistance of the branch. For a main circuit the formula usually stands thus—

$$C = \frac{E}{R_a + R_b + R_c}$$

where C is the current passing in the whole circuit, R_a is the resistance of the generator, R_b that of the apparatus to be worked, and R_c that of the cables or wires connecting them together.

It would, perhaps, be more correct to say that the above describes the useful circuit. A circuit exists wherever a path for the current exists. There is a leakage circuit, for instance, through the insulating substances surrounding the conductors in the useful circuit, and the leakage and other non-useful circuits follow the same laws as the useful circuit. It must not be forgotten, also, that the algebraical sum of all the pressures in the circuit must be used in applying the laws.

Series and Parallel Circuits.—These are terms that will be met with very frequently in discussing electrical apparatus. They mean that in series the same current of the same strength passes through

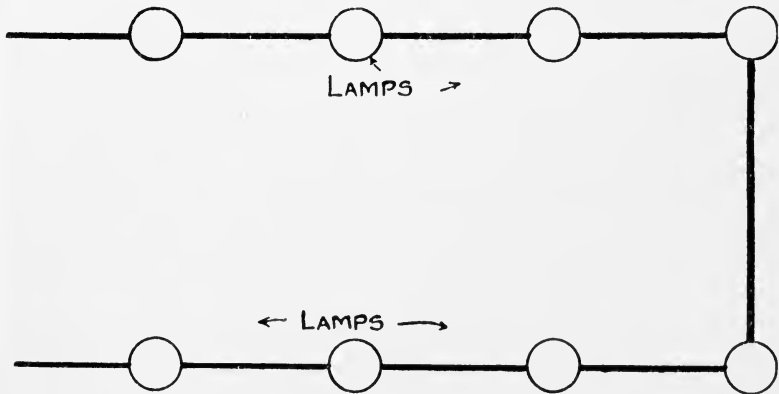

FIG. 1.—Diagram showing Series-connections. The Lamps shown are connected in Series, the Current passing through them in succession.

each apparatus in succession. Each apparatus modifies the strength of the current to the extent of its own resistance, its own pressure if it brings any, and its own back pressure if it creates any; but whatever the working of Ohm's law says shall be the current strength, that flows through the whole of the apparatus, the

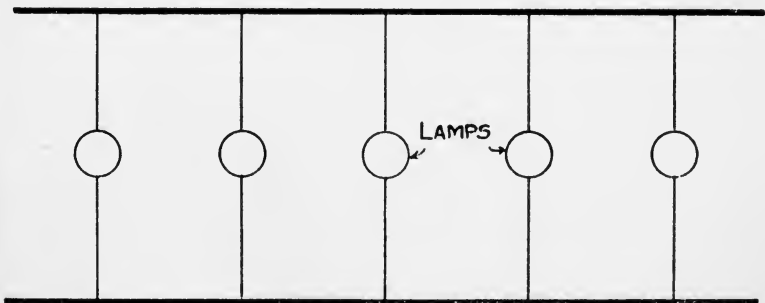

FIG. 2.—Diagram showing Parallel-connections. The Lamps shown are connected in Parallel, the Current passing through all of them together.

cables, etc., connected in the series. Thus, battery cells are always connected in series, the zinc pole of one cell being connected to the carbon pole of its neighbour, its zinc pole to the carbon of the

next, and so on, the same current strength passing through all the batteries, and all the wires and apparatus connected to them.

In parallel working the current is divided between two or more branch circuits, which are said to be connected in parallel. It is very rare that a number of branch circuits, or parallels, or derivations are connected to the same point, as, say, the terminals of a generator; but it is very common for a number of parallels to be connected to a pair of conductors, such as a pair of cables that are connected to the terminals of a generator. A familiar instance of this is a two-wire distribution service of incandescent lamps, where each lamp is bridged between the cables, the separate lamp circuits being in parallel with each other.

Modifications of the above that are occasionally employed are

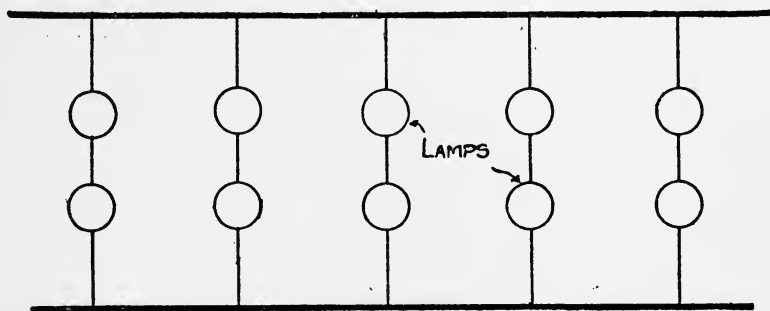

FIG. 3.—Diagram showing Series-parallel or Parallel-series Connections. The two Lamps in each Parallel are connected in Series, and the Current passes through all the Parallels together, and through the two Lamps in each Parallel in succession.

series-parallel, and parallel-series. The terms mean almost the same thing—two or more apparatus connected together in series, so that the same current passes through all of them, and the different series connected in parallel. An instance of this is the case of two incandescent lamps connected in series across a two-wire service of double the pressure the lamps are designed for. Each individual branch has its lamps in series, while all the branches are in parallel with each other. Figs. 1, 2, and 3 are diagrams of the connections of series, parallel, and series-parallel services.

Work done in Electric Circuits

The work done, or the rate of doing work in electric circuits, is measured by the product of the pressure between the ends of any conductor or group of conductors, through which a current is passing,

multiplied by the strength of the current passing. It is important to remember that the pressure must be taken when the current is actually passing, as it is less than when it is not passing. The formula for the rate of doing work is—

$$W = E \times C$$

or—

$$W = C^2 \times R$$

or again—

$$W = \frac{E^2}{R}$$

the second and third equations being found by applying the value of C in Ohm's law to the first. In the above, W is the rate of doing work, C is the current strength, E the pressure, and R the resistance; and when C is measured in ampères, R in ohms, and E in volts, W is measured in watts. The watt is the unit of the rate of doing work, and is equal to 44.22 ft.-lbs., 746 watts representing 1 H.P. For alternating currents, as explained on p. 20, the formulæ are modified by the addition of $\cos \phi$, and become—

$$W = E \times C \times \cos \phi$$

$$W = C^2 R \times \cos \phi$$

and—

$$W = \frac{E^2 \cos \phi}{R}$$

Heating Effect of Electric Currents

The heating effect, or the heat liberated by electric currents, is measured by the same formulæ as for work, heat being one form of work, but H is used in place of W .

Thus—

$$H = ECt$$

$$H = C^2 R t$$

$$H = \frac{E^2 E t}{R}$$

and H is again in watts, when C is in ampères, E in volts, and R in ohms; and 17.58 watts equal one British Thermal Heat Unit, t being the time.

The Heat Unit, or, as it is written, the B.Th. Unit, is that quantity of heat that will raise the temperature of 1 lb. of pure water 1° Fahr., the water being at 32°.

Specific heat is somewhat similar to specific resistance; it is the ratio between the quantity of heat required to raise 1 lb. of the

substance 1° Fahr. to that required to raise 1 lb. of water 1°. Most substances, and particularly the metals, have a low specific heat, this meaning that it takes a smaller quantity of heat to raise their temperatures. It will be seen that it is perfectly practicable to calculate the probable increase of temperature of any given cable, with a given current or pressure applied to it, for a given time. This is dealt with more fully in Chapter V.

Methods of producing Electrical Pressure

There are four methods of producing or, as it is usually termed, creating electrical pressure, all of which are of interest to the mining engineer.

1. By friction, as in frictional machines, some of which still survive for shot firing, in which a glass disc is rubbed against pads of silk or other substances. Electricity is also generated by the friction of steam through a pipe, that of a belt over a pulley, and generally wherever two substances are rubbed together, and the conditions are such that the electricity generated does not immediately get away. It is more than probable that the enormous pressures that exist between different clouds, and between certain clouds and the earth, during or before thunderstorms, is created to a large extent by the friction of the body of the cloud against the remainder of the atmosphere.

2. By chemical action, as in the primary, and secondary galvanic batteries, or accumulators, as the latter are called. An electrical pressure is created whenever two dissimilar substances come into contact with each other, such as two metals, and more particularly when two dissimilar metals, or a metal and carbon, are present in a liquid, an electric current following when there is a path open for it. It should be understood that it is by no means necessary that the path for the current should be external to the liquid. In the very old well-known lecture experiment, where a zinc and copper or carbon plate are immersed in dilute sulphuric acid, and it is shown that such action as does take place is at the surface of the zinc plate when no connection exists between the plates, while when the plates are connected by a wire outside of the cell, a vigorous evolution of gas takes place at the carbon or copper plate, the evolution of gas will take place equally as well if the plates are made to touch each other under the surface of the liquid. This is a very important point to remember, when dealing with the stray currents that are often met with from electric light or power services, and that are set up where iron and copper, or copper and lead, or other metals, are together in the presence of a liquid. It is supposed

that a certain pressure must exist before action of this kind can take place, and before the electrolysis which follows, and which is often so troublesome, can go on. As a matter of fact, it is difficult to have a difference of pressure so small that galvanic action, and all that it means, will not take place if the conditions mentioned above are present.

3. By magneto-electric induction, as in the dynamo machine, or, as it may be perhaps better understood, by the passage of conductors through a magnetic field. In the modern dynamo one or more powerful magnetic fields are arranged within a cylindrical space forming the centre of the machine, and the conductors are caused to cut the lines of force within this space, either by themselves being forced through the magnetic field by mechanical power, or by the electro-magnets, as will be explained in Chapter IV., that create the magnetic fields, being themselves driven through the cylindrical space in such a manner as to change the strength of the field at the points where the conductors are placed. Whenever a conductor passes through a magnetic field, it creates an electrical pressure exactly in proportion to the rate at which it is driven through the field, and to the strength of the field.

4. By creating a difference in temperature between two sets of junctions of a group of pairs of dissimilar metals, connected in one series or chain. This method, known as thermo-electricity, is only of use for measuring temperatures; but with the advance of science in connection with mining, and particularly with the greater depths and the higher temperatures that are being met with, and the importance of obtaining accurate information of temperatures, sometimes at a distance from the points where the temperatures exist, the apparatus will probably be of service. Certain metals, bismuth and antimony notably, if plates of them be joined together, and the junction be exposed to an increase of temperature, will have a difference of electrical pressure at the free ends of the two plates. In practice a number of pairs of plates are connected together in such a manner, that one set of junctions are exposed to the temperature it is desired to measure, and the other set to the ordinary temperature of the atmosphere, or any temperature that can be maintained uniform and as low as possible, and the difference of temperature is read off as a difference of pressure upon the scale of a galvanometer.

Magnetism and the Magnetic Circuit

Modern science has practically accepted Professor Ewing's theory of magnetism. Iron and steel, and, to a very much smaller extent, nickel and cobalt, are conceived to have their molecules, when they

are not in the condition we call magnetized, forming closed figures. Ewing supposes that each molecule is a tiny needle magnet, having its north and south seeking poles, and that these little magnets are arranged in groups of four or more, in such a manner that they satisfy each other's attractions, north-seeking poles and south-seeking poles lying together. When what we call a source of magnetism arrives, such as an electric current, or another iron or steel body in the state we know as magnetized, the closed figures open under the impelling force, the little needle molecule magnets turning all in one direction, and the attractions which were previously satisfied by the arrangement of the closed figures are all delivered at two points or surfaces, known respectively as the north and south poles. The piece of iron or steel that has been subject to this process has now acquired certain properties.

1. If freely suspended it will endeavour to lie in the earth's magnetic meridian, one pole turning to the earth's magnetic north, and the other to the earth's magnetic south; and if moved over the earth's surface it will tend to dip towards either the north magnetic or the south magnetic pole, according as it is in the neighbourhood of either.

2. The north-seeking pole of every magnetized body attracts the south-seeking pole of every other magnetized body, and repels the north-seeking pole, south-seeking poles repelling south-seeking and attracting north-seeking.

3. When a magnetized piece of iron or steel is brought near a piece of iron or steel not previously magnetized, it induces in the latter a state of magnetization, such that the nearer portions become magnetized in the opposite sense to the poles of the inducing body, this leading to the attraction we are familiar with in the case of electro-magnets or steel magnets for iron.

4. When the condition of magnetization has been created in any iron or in any mass of iron or steel, what are termed magnetic **lines of force** are sent out in space from the north-seeking to the south-seeking pole of the body. The lines of force assume various forms, according to the body from which they emanate. Where the two poles of the magnetized body are arranged very close together with a small space between them, the great majority of the lines of force pass in straight lines from one pole to the other. Where other masses of iron lie in the path of the lines of force, they modify the curves the latter take, the lines passing preferably through the iron, and resuming curves of various forms after leaving it. In the dynamo the lines of force pass in straight lines from the poles of the field magnets across the air space between them and the armature, and in more or less curved lines, according to the number of poles present, as will be explained in Chapter IV. in the iron of the

armature. The lines of magnetic force behave in many respects like the electric current.

There is a **magnetic resistance**, or **reluctance**, as it is sometimes called by preference; that is, all bodies offer a certain resistance to the passage of the lines of force through them. Iron and steel offer very much less resistance than any other substances. Air and the insulating materials that are used in connection with electrical apparatus offer practically the same magnetic resistance, and, according to Professor Kapp's measurements, 1400 times that of the resistance offered by wrought iron or mild steel. The different qualities of iron and steel offer different resistances, cast iron having a resistance about twice that of the best wrought iron at the point of saturation usually adopted. The mild steel that has been introduced for so many purposes within the last twenty-five years, has practically the same magnetic resistance as the best Swedish wrought iron. A special form of steel made at Sheffield by Messrs. Hadfield and others has a rather lower magnetic reluctance than even the best Swedish iron, while alloys of iron and nickel, and of iron and manganese, have very high reluctance. For nearly the whole work for which magnetism is used, excitation is by means of electric currents passing in wires, coiled round the mass of iron to be magnetized; and there is a definite relation between the strength of the current passing in the wires, the number of times they pass round the body to be magnetized, or the number of ampère turns, as it is usual to express it, and the number of lines of force created in any electro-magnetic system with any given magnetic reluctance. The number of ampère turns is sometimes called the magneto-motive force, and it bears the same relation to the magnetic reluctance, made up of the resistance offered by the iron of the field magnets, etc., of the system, and the air spaces, as the electrical pressure does to the resistance offered by conductors and insulators to the passage of electricity.

What is known as magnetic permeability is the ratio between the magnetic flux density, the number of lines of magnetic force per square inch, or per square centimetre, when a metal is present, and that when only air is present, and this ratio is expressed by the Greek letter μ . It is usual to express a flux density that would be produced in air with a given number of ampère turns by the letter H , the number that is produced in a given specimen of iron by the letter B , and the ratio between B and H , which expresses the relative permeability of the specimen, by the Greek letter μ . The permeability varies from 0.999 for bismuth up to 4000 for special qualities of Swedish iron and magnetic steel.

In the dynamo, and in every electro-magnetic apparatus, there is a magnetic circuit, built up of the iron cores of the electro-magnets, the iron yoke connecting them at the back, and the

iron armature which, with the air space between the magnetic pole and the armature, completes the circuit. The simplest case, and one which shows the magnetic circuit in its simplest form, is that commonly employed for electric bells and similar apparatus. Commencing from the north-seeking pole of the electro-magnet, the lines of force pass across the air space to the iron armature in front of the poles, through the iron armature to the air space opposite the south-seeking pole, across the air space to the south-seeking pole, through the iron core to the yoke, through the yoke to the other leg of the magnet, down the other leg to the north-seeking pole. In the dynamo there may be, and in the modern dynamo usually are, several magnetic circuits, but the lines of force pass in exactly the same manner, from the north-seeking pole across the air space to the armature, through a portion of the armature, across the air space, and through the magnet and its yoke.

The larger the cross-section of the magnet cores and the shorter their length, the lower is the magnetic reluctance of that part of the magnetic circuit; and the shorter the distance between their magnetic pole and the armature, and the larger the area of the armature embraced by the magnetic pole, the lower is the resistance of the important portion, the air space.

Difference between Alternating and Continuous Currents

The apparatus that have been described uses what have been termed, in contra-distinction to the alternating form, continuous currents. The continuous current passes always in the same direction. Whether it be a wave motion or a procession of charged corpuscles, it commences from one pole of the generator called the positive, passes through the wires, cables, etc., connecting the generator with the apparatus to be worked, through the apparatus to be worked, the cables, etc., completing the circuit, back to the generator, and *through* the generator to the positive pole from which it set out. Alternating currents are constantly changing in direction and in value. Thus, a current will set out from one pole of the generator which for the moment is the positive, will pass through the cables and the apparatus to be worked, back to the other pole of the generator which for the moment is the negative pole, and through the generator to the pole it set out from. Then a current in the opposite direction sets out from the pole which was the negative with the first current, and passes through the circuit and the generator in the opposite direction to the first. This is succeeded by another current in the first direction, and so on, these

opposite currents succeeding each other at from fifty times a second upwards. In addition to this, the currents are constantly changing in value. The first current which commences is at first very weak, it gradually increases to a maximum, then gradually falls to zero, and it is when it has fallen to zero that it is succeeded by the second current in the opposite direction, which also commences from nothing, rises gradually to a maximum, falls to zero, and is again succeeded by a reverse current. The laws governing the working of circuits in which alternating currents are used are the same as the laws governing those in which continuous currents are used, but certain additions have to be made to the equations employed, and certain values have to be taken for the pressures and currents.

Virtual or Effective Volts and Ampères.—For the calculations that are employed with alternating currents for Ohm's law, etc., what are termed virtual or effective pressures, and currents are used. They are the pressures and currents which would perform the equivalent heating, if continuous currents were employed. What is required is a certain average pressure and average current, but the ordinary rule of averages will not apply, because the currents and pressures do not increase in the regular proportion, but in that in which the values of the sine of an angle ranging between 0 and 90° increase, and it is an average obtained from the changes in the value of the sines. Stated accurately, the effective or virtual pressure or current is the square root of the mean of all the values of the pressures and currents throughout a half-period. A complete cycle or period consists of the increase from zero to maximum in one direction, the fall to zero, the increase to the maximum in the opposite direction, and the fall to zero again. The rule for the effective values is based upon the fact that the heating value of any current, and of any pressure, with the resistance of the conductor constant, varies as the square of the current, and as the square of the pressure delivered to the conductor. The mean required is the mean of the heating effects of all the values assumed by the pressure and the current, and obviously the square root of this sum, whatever it may be, will be the effective working or virtual pressure and current to be used in calculations. Put in another way, the effective pressure is that which enables makers of incandescent lamps to label their lamps for any pressure, which is applicable to continuous or alternating current supply. The effective pressure and the effective current are both 0·707 of the maximum pressure and current reached in either the positive or negative direction; or, put the other way, the maximum pressure and the maximum current in either direction are 1·414 times the effective or working pressure and current. One important effect of this will be seen from the fact that when we talk of an alternating current of 100 or 1000 volts, we actually have

pressures at different instants, 141.4 volts in the one case, and 1414 volts in the other case of opposite name; or a difference of pressures at successive instants, half a period apart, of 282.8 and 2828 volts respectively.

Two-Phase and Three-Phase Circuits

The alternating current described on p. 14 is known as the single-phase current. In France it is usually called the simple alternating current. Both terms are employed to distinguish it from two, three, and poly phase currents. Two-phase currents are merely two single-phase currents, usually generated in one machine, which follow each other, separated in time by a quarter of a period. The currents of the two phases have the same periodicity. If fifty periods is the frequency, each current completes its cycle, rising and falling and reversing in one-fiftieth part of a second. But the second current does not commence to rise on its positive side until the first current has passed through a quarter of its cycle. That is to say, the second current is at its zero, commencing its ascent to its positive maximum when the first current has reached its positive maximum. When the second current reaches its positive maximum, the first current has reached its second zero. When the second current reaches its second zero, the first current has reached its negative maximum, and so on, the two currents being always separated by a quarter of a period, or by an angle of 90° ; or, as it is often expressed, they are in quadrature.

Three-phase currents are merely single-phase currents succeeding each other in the same manner as the two currents of a two-phase service do, but the currents are separated by an interval in time of one-third of the total period of the single-phase current. That is to say, with three-phase currents the second current commences to rise when the first current has completed one-third of its cycle; that is, when it has reached its maximum, and accomplished one-third of its descent to its second zero. When the second current reaches its positive maximum, the first current has passed through its second zero, and is one-third on its way to its negative maximum, and so on, the two currents being always one-third of a period or 120° apart. The third current commences when the second current has accomplished one-third of its cycle, and when the first current has accomplished two-thirds of its cycle. When the third current is at its first zero, and about to commence its first ascent to its positive maximum, the second current will be passed through its positive maximum, and be one-third the way down to its second zero, while the first current will be passed through its second zero, and be two-thirds on its way

to its negative maximum. The third current follows the second current in the same manner as the second current follows the first, the three currents always being separated by one-third of a period in time and 120° .

In America, four-phase and six-phase currents are sometimes employed, particularly six-phase, though they have not hitherto been used in this country.

With four-phase currents there are merely four single-phase currents, separated in time by a quarter of a period, and succeeding each other at the different maxima and zeroes by this amount. With six-phase currents there are six single-phase currents, succeeding each other at intervals of one-sixth of a period of the cycle, and being always separated by that amount and by 60° .

Electrostatic Induction and the Capacity of Cables

The electrostatic capacity of cables has only recently become of importance in mining work, and only owing to the fact that difficulty arose in measuring the leakage currents on three phase services, because the capacity currents apparently masked the leakage current.

When an electrical pressure is applied to any cable, and more particularly when the cable is either lead covered or armoured, before the current which the pressure causes to pass through the cable can reach the end of the cable, an electrostatic charge has to be delivered to the insulating envelope of the cable. The insulating envelope, whether it be indiarubber, bitumen, paper, or fibre, has what is termed an electrostatic capacity; that is to say, a capacity for absorbing a certain quantity of electricity in the same manner as the Leyden jars, with which we are so familiar on lecture tables, do. The insulating envelope may be likened to a sponge into which the electricity soaks, and the current that is to perform work at the end of the cable cannot pass on until each length of the insulator—each foot, inch, yard, etc.—has soaked to its full capacity.

The quantity of electricity the insulator will absorb depends directly upon the pressure between the conductor and the lead covering or armour, or whatever the outside of the cable may be in contact with; it depends also directly upon what is termed the specific inductive capacity of the material itself, that of indiarubber being 2.34 to 2.94, and of the impregnated paper used for the insulation of paper-covered cables 2.5.

It also depends directly upon the extent of the surfaces of the conductor, and of the armour or lead covering, or other substance on

the outside of the cables, that are opposed to each other, and inversely upon the thickness of the insulating envelope. It will be seen that it is an advantage in this matter to have a thick insulating envelope, and that paper-covered cables have an advantage over both india-rubber and bitumen covered. It will be seen, also, that long cables, such as are often used in mines, may have a comparatively large electrostatic charge; and, further, that the cables employed with three phase work are under the best conditions for absorbing a comparatively large charge. When the pressure is removed, as when the circuit is opened, the charge which is held in the cable is released, and immediately commences to flow back into the conductor from which it was received. A decrease of pressure operates in the same manner, though to a smaller degree than a complete cessation of the pressure. Also, an increase of pressure operates exactly as a newly arrived pressure. With alternating currents, the pressures are continually rising and falling and reversing, and therefore in cables that are employed for alternating current services, the condenser, as it is called, formed by the conductor, its insulating envelope and the external conductors, is being continually charged, discharged, and recharged in the opposite direction, the result being that there is an absorption of a certain quantity of electrical energy by the insulator of the cables.

The returning current from the condenser gives rise to an electrical pressure in the conductor, not actually in opposition to the pressure creating the current from which the original condenser charge is obtained, but in quadrature with it. That is to say, the pressure created by the condenser action occupies the same position with reference to the pressure creating the current normally in the conductor, as the two currents in a two phase service do to each other. The pressure created by the condenser action has what is known as a *lead*. After the service has been in operation a sufficient time to charge the condenser, and to allow it to discharge, the pressure created by the condenser is in the position that would be represented by a current 90° in advance.

The condenser pressure opposes that created by electro-magnetic induction, as described on p. 19, and if the two can be made to balance, the primary pressure is less than it otherwise would be. If it is not balanced, an additional pressure has to be added to the ordinary pressure than would be necessary to drive a given current through the system of conductors forming the service. The condenser pressure is, however, usually of very little importance.

Electro-Magnetic Induction

In addition to charging the electrical condenser, of which the conductor of a cable forms a part, the current which passes through any conductor under the influence of an electrical pressure has to create an electro-magnetic field around each unit, each inch or yard of the conductor, before it can pass on to the next inch, yard, etc. With continuous currents this phenomena, as also that of the condenser charge, merely delays for a very inappreciable time the first passage of the current through the conductors, and the apparatus they are connected with. But with alternating currents, which are rising and falling and reversing constantly, there is a constant creation of an electro-magnetic field round the conductor, and a constant delivery of the energy which created the field, to the conductor from which it was taken, a constant recreation of the field in the opposite sense, followed by a redelivery to the conductor, and so on. This leads to what is called the *lag* of the current behind the pressure which creates it.

Even with alternating currents the lag is not of importance with a straight cable, unless the cable is very long, and the periodicity of the current is very high. But in all dynamo machines, whether constructed for generating current, or for converting current into mechanical power, the conductors which create the magnetic fields in the machines are coiled on themselves a very large number of times, and the variation of the current in each coil acts upon all the turns of the conductor, the result being that the total inductive effect, the self-induction as it is termed, is multiplied very considerably, and with alternating current dynamos and motors, the lag caused by the electro-magnetic induction is often very considerable.

The reduction creates a pressure acting at right angles to the pressure of the service. The pressure created by electro-magnetic self-induction is in direct opposition to the pressure created by the electrostatic induction. The electro-magnetic induction is, however, by far the most important of the two, and it usually leads to the necessity of modifying the formula for calculating the power expended in any electrical circuit, by the addition of a factor allowing for the current not acting at the same instant as the pressure. With the great majority of alternating current circuits, especially where there are a number of motors in use, the current lags considerably behind the pressure that creates it, owing to the electro-magnetic induction referred to, and only a certain portion of the current can be taken as acting at the same instant as the pressure. This factor is proportional to the cosine of the angle by which the current lags behind the pressure. If the pressure be represented by a radius sweeping

out an angle round a centre, the current is represented by a second radius a certain number of degrees behind the first, and it is the cosine of the angle between the two that represents the additional factor that has to be applied to the ordinary power formula. The angle is termed ϕ , and cosine ϕ is called the power factor. Reference to a table of cosines will show that when the angle is 0, the cosine = 1, and when the angle is 90, the cosine = 0.

In practice it is usual to take the value of cosine ϕ for calculations as 0·8, but it may have as low a value as 0·5, and with what are termed non-inductive circuits, circuits in which only incandescent lamps are employed, and in which there are no electro-magnets or other arrangements of wires coiled on each other, it is usually 1, or nearly so.

The Impressed Pressure in Inductive Circuits.—The presence of electro-magnetic and electrostatic induction obliges a higher pressure to be maintained by the generator than would otherwise be necessary, unless the two inductive actions neutralize each other. The additional pressure required, or the total impressed pressure or impressed voltage, as it is termed, is found by a simple adaptation of the parallelogram of forces employed in mechanics. The pressure creating the current and the induced pressures are at right angles to each other, as explained. If, then, the two are set out in the manner of the parallelogram of forces, the original pressure demanded by the ohmic resistance of the circuit forming one side of the parallelogram, the net induced pressure forming another side, and the parallelogram be completed, the diagonal of the parallelogram, which is also the hypotenuse of the triangle formed by the original current pressure—the C^2R pressure, as it is often expressed—and the induced pressure, gives the value of the impressed pressure, and it may be measured graphically by scale, or calculated by using the 47th proposition of the first book of Euclid, the square root of the impressed pressure = the square root of the sum of the square of the current and induced pressures; or, put into a formula—

$$E_i^2 = E_c^2 + E_a^2$$

$$\text{or } E_i = \sqrt{E_c^2 + E_a^2},$$

where E_i is the impressed pressure, E_c that due to the current, and E_a that due to induction.

Electrolysis

Electrolysis is the phenomena which operates in galvanic batteries, both primary and secondary, causing the liquid electrolyte to be split up into its components, one body of the components, the

non-metals, appearing at the **anode**, the plate where the current enters the liquid, and the other the metals and hydrogen gas, which behaves as a metal in this case, appearing at the **cathode**, the plate where the current leaves the liquid. In the Leclanché battery the electrolytic action splits up the water and the chloride of ammonium (sal ammoniac) into its components, the oxygen and chlorine gases appearing at the zinc plate, and the hydrogen and ammonia gases appearing at the carbon plate. In this case the hypothetical metal ammonium is delivered at the carbon plate, and is split up into ammonia gas and hydrogen gas. It is the hydrogen gas which gives so much trouble in the primary galvanic battery. When it is delivered at the carbon plate it sets up a pressure opposing that of the primary current which created it. In the secondary battery or accumulator, the solution of sulphuric acid is split up into the acid radicle SO_4 and hydrogen, the acid radicle being again split up, and this being the source of the oxygen on the one hand, which oxidizes the active material on the positive plate to a higher oxide, and of the hydrogen, which reduces the active material on the negative plate to the metallic state. But electrolysis has a very much more important bearing upon the use of electricity in mining, than merely the part it plays in batteries. Wherever a current passes through a liquid, no matter how small the pressure may be, and no matter how small the surfaces of the metals from and to which it passes, nor, again, how small the quantity of liquid through which it passes may be, electrolysis takes place, the liquid being split up as explained; and as all liquids contain oxygen and hydrogen, oxidation of the surface of the metal from which the current passes also always takes place. This leads in many cases to metals about the mine being eaten away, sometimes in a mysterious manner. Under the very best conditions leakage always takes place from the lighting and power service, and the leakage current finds its way by every path that is open to it back to the machine; and it often happens that the path includes metals, such as iron rails, ropes, pulleys, and so on, and wherever the current passes from a metal, it invariably attacks the metal. The current may be small, but it is always acting, and the results may be serious.

CHAPTER II

ELECTRIC MINING SIGNALS AND TELEPHONES

Electric Mining Signals

THERE are only two forms of signal employed now in mines, those for signalling from any part of engine roads to the engine-man and to the hooking-on stations, and those for working the cages in the shaft. Shaft signals have not even yet been much adopted in English mines, but engine-road signals are almost universal.

The Engine-road Signal.—In the engine-road signal there are two or three naked galvanized iron wires stretched tight to the full

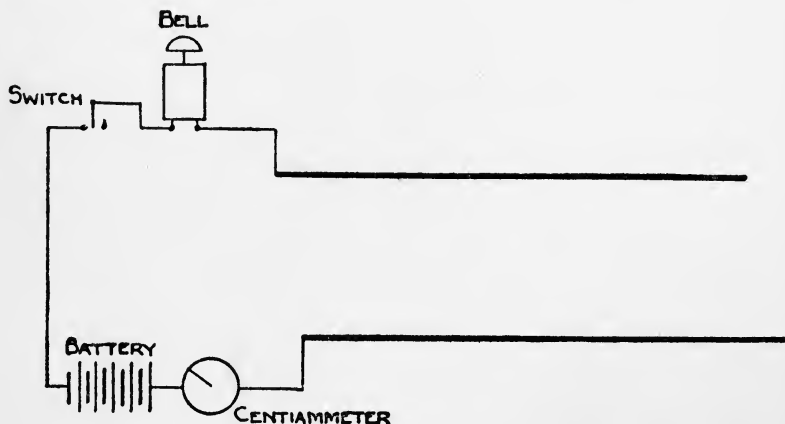

FIG. 4.—Diagram of Two-wire Engine-road Signal, with one Bell, Battery, Switch, and Centiammeter.

length of the engine road, and secured to insulators which are held by the props on the side of the road, or, where that is not convenient,

by the beams, or again by stout plugs driven into holes drilled in the coal or rock. In the simplest form of signal there are two wires, one bell, and a battery in the engine-house, and a circuit is formed, as shown in Fig. 4, so that when connection is made between the two naked iron wires at any part of the engine-road, the circuit is completed, and the bell rings. An extension of this is the signal working to an engine-house at bank, with a repeating bell at the pit bottom. In this case the bell and battery are in the engine house at bank. There are two insulated copper wires in the shaft, and they are connected to the naked iron wires in the engine road in such a

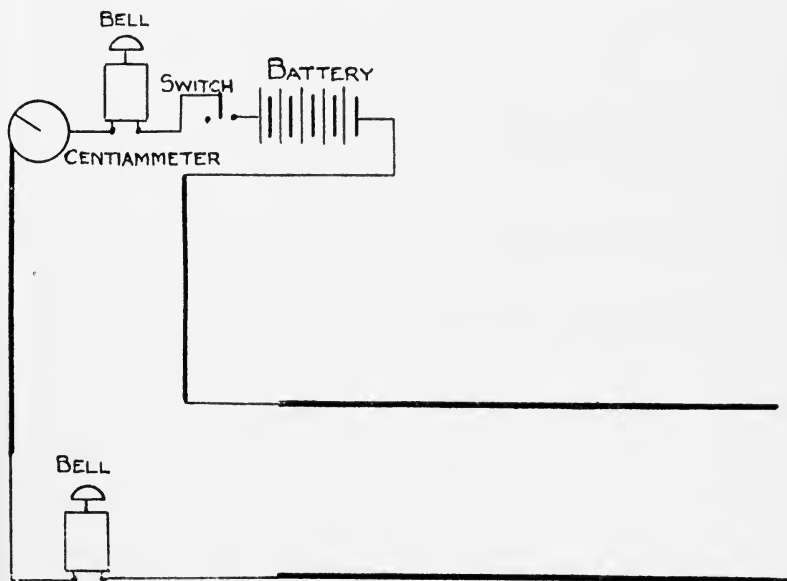

FIG. 5.—Diagram of Two-wire Engine-road Signal, as arranged for signalling to the Shaft-bottom and Engine-house simultaneously, with two Bells, one Battery, Switch, and Centiammeter.

manner that, as shown in Fig. 5, the two bells are included in the circuit when connection is made between the iron wires. Another extension of the signal is shown in Fig. 6, where there is a bell and battery in the engine-house, and a second bell at the end of the engine road with three wires, connection between two of which completes the circuit and rings both bells. A further extension, and one that has come very much into use since the general adoption of the endless rope system, is, there is a bell in the engine-house and a battery as before, a bell at the end of the road, and one at each of

the hooking-on stations. There are three wires, and connection between two of them causes all of the bells to ring together. The bells may be connected either in series or in parallel, as shown in Figs. 7 and 8. The series system requires the largest number of cells in the battery; the parallel system requires that there shall be the largest individual cells in the battery, if the signal is to keep up to its work, as it makes the largest drain. The parallel system also requires that the bells shall be exactly alike in construction, and especially that the resistance of the bell coils shall be exactly alike. The resistance of the bell coils is higher than would be necessary with the series system so as to allow for the difference in the pressure at the bells farthest from the battery. If one of the bells

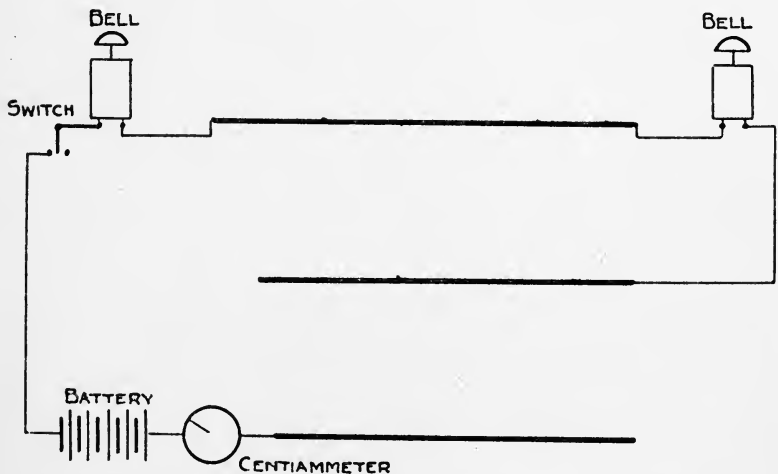

FIG. 6.—Diagram of Three-wire Engine-road Signal, with Bells at each end of the Road, one Battery, Switch, and Centiammeter.

has a lower resistance than the others, it will take more current than they do, and may lead to the others not working, especially when the battery works down.

The Willis Engine-road Indicator Signal.—This is a further development of the engine-road signal that has been worked out by Mr. Willis, of the Lycett Collieries in North Staffordshire, and applied there with success. A difficulty is sometimes met with in letting the engine-man know what portion of the road has stopped him. The usual practice is one rap on the bell is given for "stop," two or three raps for "go on." With the endless rope system trams are being hooked on at all parts of the road at all times, and the rope is

required to be stopped only when the hooker-on has trouble with his tram. It may and does often happen that two or more

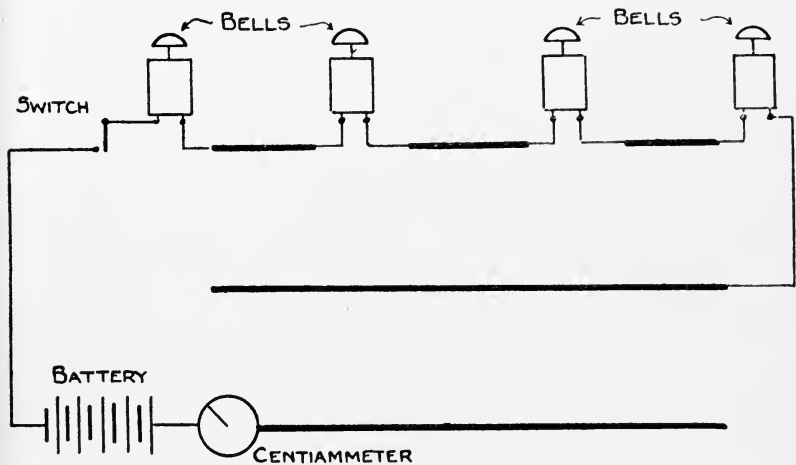

FIG. 7.—Diagram of a Three-wire Engine-road Signal for Endless Rope Haulage, with Bells at each Branch Road, the Bells being connected in Series, with one Battery, Switch, and Centiammeter.

hookers-on rap for "stop" at the same time, or in immediate succession, and the man who gets his tub clear first will rap "go on,"

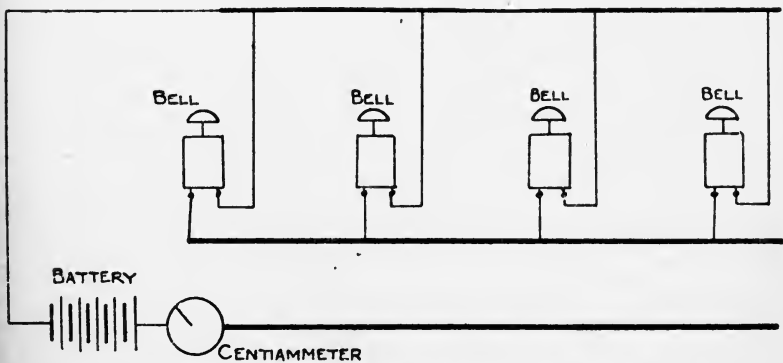

FIG. 8.—Diagram of Three-wire Endless Rope Haulage Signal, similar to Fig. 7, but with the Bells connected in Parallel.

not knowing that the other man is not ready. If the engine-man goes on he may cause damage to the tram, and possibly to the man

who is handling it. The Willis system is intended to prevent this by showing the engine-man which section has stopped him, and then he will not go on again, no matter who else signals him, until he receives the signal from each one that has signalled "stop." Mr. Willis divides the road into a certain number of sections, presumably according to its length. A road is divided into six sections, as arranged in a set of signals in practical use at Lycett. The naked iron wires that were described in connection with engine-road signals generally are employed; but one of them is broken at each junction between successive sections, and at the break an electrical resistance is inserted, which is also made to do duty as a relay, as will be explained. It will be seen that in the first section of the road, that nearest to the engine-house, the only resistance in the circuit, when a signal is given, is that of the two naked iron wires, and that of the apparatus in the engine-house. In the second section there will be the resistance of the iron wires of the first section, that of the resistance interposed between the two sections, and whatever portion of the iron wires in the second section may be included up to the signalling point. In the third section there will be two additional resistances besides the iron wires, and so on. In the engine-house there are as many relays as there are sections. The relay is described on p. 36. It is, shortly, an electro-magnet, through which a small current is intended to pass, and whose armature is intended to close a second circuit, bringing into operation a larger current with bell and battery, or whatever may be arranged. In addition to this usual arrangement, Mr. Willis causes the armatures of his relays in the engine-house to perform a double office. The relays are all connected in series, the current passing directly to the coils of the first relay, thence to the armature of its relay, and from the back stop of the first relay to the coils of the second relay, from thence to its armature, and from its back stop to the coils of the third relay, the back stop of the third relay to the coils of the fourth relay, and so on. So that if the armature of any relay of the series is pulled up to its electro-magnet, the circuits of all the relays behind it are broken, and no current passes to them. Thus, if the first relay is actuated, the second, third, fourth, fifth, and sixth relays are all dead. There is a separate relay for the bell, actuated at the same time as each one of the other relays, and working with them. The different relays are arranged to respond to the current from the different sections of the road, No. 1 relay to No. 1 section, No. 2 relay to No. 2 section, and so on. The armatures of the relays are opposed by springs. Mr. Willis occasionally uses weights of gradually decreasing tension or leverage. The tension of the spring, or the leverage of the weight opposing the pull of the electro-magnet of No. 1 relay for its armature is stronger than

that of No. 2; the spring of No. 2 is stronger than that of No. 3, and so on. The currents arriving from the different sections are weaker as the section is further from the engine-house, the current from No. 1 section being stronger than that from No. 2; the current from No. 2 stronger than that from No. 3, and so on. Hence it follows, if everything is in order, that the relay of No. 1 will only respond to the stronger current sent from No. 1 section; the relay of No. 2 will respond to the current sent from No. 2 section; but not that from Nos. 3, 4, and so on. The current from any section passes through its own relay, pulls up its armature, cutting off the weaker relays behind it, closes its own local circuit with the battery provided for it, and shows, either by means of a disc in front of a glass, or by a lamp behind a glass, the section which has signalled. The bell, which is common to all the sections, has its own relay, which is actuated by the smallest current and rings from any section. The resistances which are interposed between the sections of the iron wires are made to do duty as relays to work the return signal bells. On the endless rope-engine road it is usual to have a bell at each hooking-on place, and in this case the engine-man will ring all the bells from a key in the engine-house when he is going to start, so that all the hookers-on will know. The principal difficulty in connection with this apparatus is, maintaining the tensions of the springs at their proper figure. Some years ago, when electric signals were first being introduced into coal mines, this would have been serious. At the present time, when electricity is so largely employed about coal and metalliferous mines, it ought to present no difficulty whatever. The electrician who can look after a dynamo, a motor, starting-gear, etc., can, if he will, easily look after an apparatus of this kind, and it appears to the author that the application of the apparatus is capable of very considerable extension.

Sources of Current for Mining Signals

As is explained on p. 28, open-type Leclanché, open-type mercury bichromate, and dry batteries are usually employed for electric signalling, the last gradually displacing the others. In the early days of electric light in mines, however, several signals were worked by means of current taken from the lighting service; but this is very dangerous, and is absolutely forbidden by the Home Office regulations for the use of electricity in coal mines. There is no reason, however, that in those mines where there is a power service, no matter what it may be, whether 500 volt continuous, 440, 500, or 3000 three-phase alternating, that it, or the lighting service, should not be used to work the signals, by the aid of motor

generators. As will be explained in Chapter IV., the motor generator consists of two distinct machines, the axles of the revolving portions of the two being mechanically connected. One machine receives current from the supply service, transformed down if necessary by stationary transformers, as will be explained, to any convenient pressure. It runs as a motor, and drives the other machine as a generator. The second machine generates current at whatever pressure may be desired. In the present instance it might be a pressure of 10 or 20 volts, and the current might be any that was convenient. If the motor generator is properly constructed, there should be no connection whatever between the supply service and the electric signal service, while the latter would be worked very much more conveniently, and indicating lamps might be added to the present bell signals with great advantage. One of the difficulties in connection with Mr. Willis' indicating signal, and for which he has felt obliged to provide an adjustable rheostat, viz. the difference in the current strength delivered to the signal, owing to the different condition of the battery at different times as its life increases, would be completely overcome. With reasonable attention the current delivered to the signals should be practically the same at all times, and Mr. Willis' or any similar apparatus should easily be able to be worked. Further, motor generators could be placed in any convenient position where it would be handy to have an electric signal, the attention they require being very small, if properly arranged. A battery of accumulators may also be used for working any individual signal, or for working all the signals about the mine. Mr. Willis informs the author that he has adopted the latter method at Leycett. A similar method, but with large Leclanché open-type cells, was adopted at Annesley Colliery many years since.

Forms of Galvanic Battery

At the present time there are only three forms of primary galvanic battery that are of any use for mining work, and two of them are giving way rapidly to the third.

The forms are the open-type or wet Leclanché, the mercury bichromate, and the dry cell. The Leclanché battery hardly requires description. It consists of an outer glass or earthenware jar, containing a solution of sal ammoniac, in which are immersed a zinc rod, having a copper wire attached to it for the purpose of connecting to the next cell, or to the service, and a cylindrical porous cell holding a lead-capped carbon plate standing in a mass of carbon and oxide of manganese, crushed to about the size of a pea, the porous cell being sealed over with pitch, and the lead cap having a brass

terminal screw for action. There are several chemical actions going on in the Leclanché cell when it is furnishing current, the principal of them being, the zinc is dissolved in the solution, and the oxide of manganese is gradually deprived of a portion of its oxygen. In addition, the sal ammoniac is gradually used up, and the pores of the cylindrical jar are also gradually filled up, so that a large increased resistance is offered to the passage of the current.

In the mercury bichromate cell there is the same outer containing jar, usually of glazed earthenware, holding a solution of either bichromate of potash and sulphuric acid, or of the commercial chromic acid, which contains a large percentage of sulphuric acid; a cylindrical porous cell standing in the solution, and having inside it a zinc, made in the form of a truncated cone with a stout cylinder above, into which a copper wire is cast. The zinc stands in a bath of mercury in the porous cell, the latter being filled at first either with plain water, or water to which a small quantity of sulphuric acid has been added. There are also many complicated actions taking place in the mercury bichromate cell, the principal of which are the gradual dissolving of the zinc in the solution in which it stands, and the gradual using up of the bichromate of potash, or the chromic acid, the porous cell also having its pores gradually filled up as in the Leclanché. The mercury bichromate cell has much better staying power than the Leclanché, but it is sometimes more difficult to look after, and the acid is more unpleasant to handle than sal ammoniac.

The dry cell is really an enclosed Leclanché cell. It consists, in nearly every form, of a thin hollow cylinder of zinc, and a carbon rod with a mass of crushed carbon and manganese compressed round it, the rod with its manganese standing in the middle of the zinc cylinder, and the space between it and the zinc being filled with a pasty mass, consisting either of plaster of Paris, gypsum, or other substance, mixed with a solution of sal ammoniac. The top of the zinc cylinder is sealed over with pitch, and in the best forms the whole is placed inside a glazed porcelain cylinder. The action of the dry cell is exactly the same as that of the open Leclanché, and its useful life, its ability to do work, depends upon the quantity of oxide of manganese that can be usefully exposed to the current, and upon the quantity of the solution of sal ammoniac that can be held in the pasty mass of plaster of Paris, etc. The dry cell is making headway because it is so clean and so convenient. The battery man can easily take a few dry cells down the pit in his bag, or can keep a few in a cool place near the battery, and it is a very simple matter to change any cells that are run down. They are not so economical in material as either the open-type Leclanché or the mercury bichromate, but in the great majority of cases they are very much

more economical in attendance, and the labour saved more than pays for the additional material used. Unfortunately there are only a few forms of dry cell that are really reliable, though improvements in manufacture are gradually bringing more and more into the market.

Fitting up Engine-road Signals.—Engine-road signals are usually fitted with No. 8 galvanized iron wire, stretched tightly along one side of the road, and fixed to small reel insulators of glazed earthenware. The insulators are about $1\frac{1}{2}$ inches in diameter. They have a hole through the centre large enough to take a No. 20 iron-wood screw, and they have a groove on the edge in which the galvanized iron



FIG. 9.—Reel Insulators used with Engine-road Signals.

wire. They are shown in Fig. 9.

Note.—In binding wires to insulators, whether the wires are covered or not, be sure always to use the same kind of wire for the binding as the conductor is made of. Use galvanized wire for binding in galvanized iron or steel, and copper wire for binding copper conductors, never the reverse of these, or galvanic action will be set up that will inevitably lead to trouble.

Another form of insulator that has been employed is one—a modification of that which is used for fixing covered electric light wires in buildings—where the wires are not laid in wood boxing or conduits. The insulator is made in two halves, that is to say, two discs, each having a hole for the screw in the centre, and each having a groove cut along the face of the parts of the insulator which come together, in which the wire can lie and be held tight by screwing the two parts of the insulator together. Another form of insulator that has been employed is a reel made of vulcanized indiarubber. It is rather less expensive than the glazed earthenware, does not break so easily, but is not as strong. It is shown in Fig. 10. For straining iron wires, too, at the ends of the roads, a very much stronger insulator is employed, known as the shackle or shackle insulator. It is 3 inches in diameter, about 2 inches thick, with a hole in its centre large enough to take a $\frac{3}{4}$ -inch bolt, and a groove about its edge large enough for two thicknesses of the iron wire to lie in. It is shown in Fig. 11. The shackle insulator is held between two galvanized iron straps by means of a galvanized iron bolt or nut, the other ends of the straps being secured to a prop or any convenient position by an iron-wood screw. The end of the iron wire is taken twice round the groove in the body of the

insulator, and is secured by being twisted several times round its own part. The iron wire is then stretched out to the full length of the road by means of a telegraph wire-man's straining vice. The straining vice consists of a hand-vice attached to a small drum

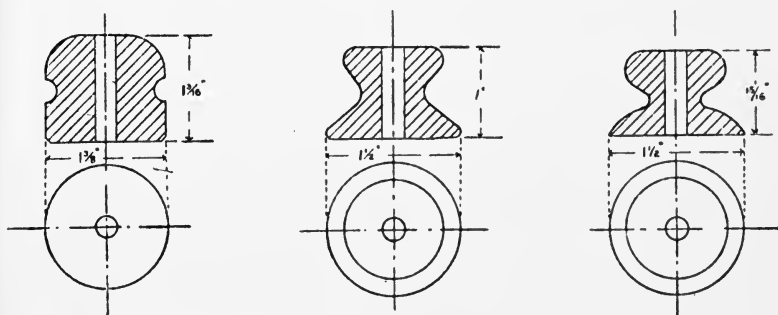

FIG. 10.—Forms of Vulcanized Rubber Insulators made by the Avon Rubber Co.

with a ratchet and paul, the connection between the two being by means of a swivel. The vice is clipped on the wire, a small length of another wire is attached to the small drum, and the wire is tightened up to a prop ahead, another vice tightening up in front

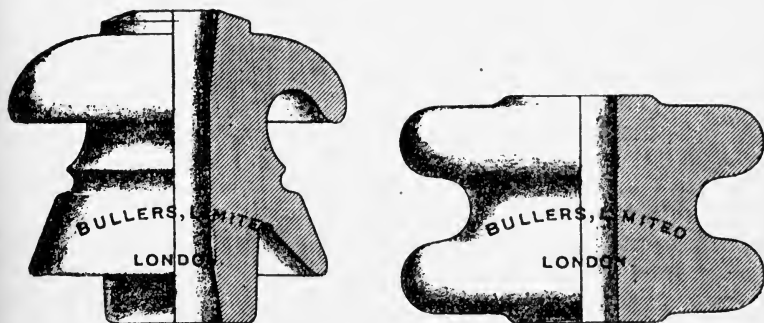

FIG. 11.—Forms of Shackle Insulators used for terminating Engine-road Signal Wires.

to another prop, the whole being secured to the insulators after tightening. The wires should be "shackled off," as it is termed, on each side of each junction of the engine road—say at each hitching-on place—the connection between the different sections being made

by means of insulated wire. It will be seen that it is easy to insert Mr. Willis' relays at the different junctions by this method. In the engine-house the usual circuit is formed of a battery, now nearly always consisting of dry cells; a bell, which may be single stroke or trembling, but is more frequently the latter; and a switch, which may be of the plug or lever form, to disconnect the battery when the signal is not required to be used. The author would very strongly advise the addition to the above of a low-reading ampère meter. It should be made to read in one-hundredth parts of an ampère. Instruments are now made for all ranges. Milliampère meters are quite common, and there should be no difficulty in making centiampère meters. The reason the author so strongly recommends this is, the

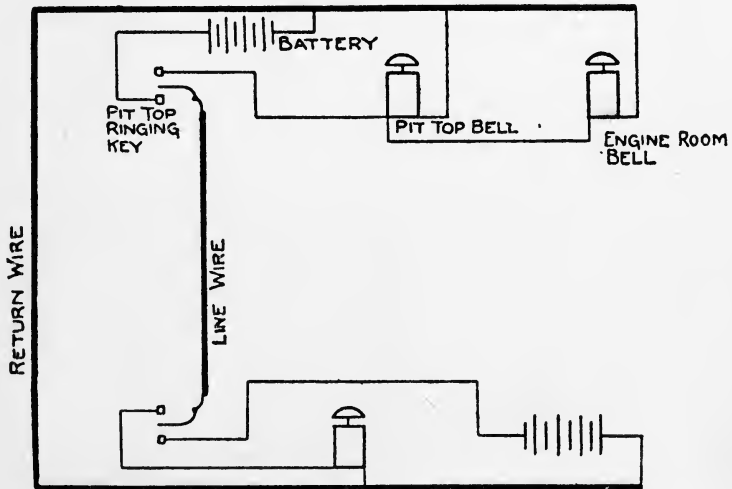

FIG. 12.—Diagram of Connections of a Shaft Signal with three Bells, two Batteries, and two Ringing-keys.

great difficulty with engine-road signals is leakage of the current. Where roads are wet, and where especially insulators are allowed to be broken and not replaced, insulation of the wires steadily goes down, with the result that faulty signals are given after a time. The presence of the centiampère meter would show the electrician in charge, the gradual increase of his leakage current, and it would also be an additional guide to the engine-man when a signal was given. When there is a large leakage, the single-stroke bell is apt to keep its armature up to its magnet, while the trembler bell is apt to maintain a continuous chattering, the result being in either case that the engine-man has to judge by his experience when a signal has

been given. With a centiampère meter in the circuit, the throw of the needle when a signal was given would be a very useful additional indication.

Very Important Note.—The wires for engine-road signals should be kept, under all circumstances, well away from cables carrying currents for the electric light or power service, no matter whether the latter are armoured or unarmoured. Where it is possible, signal wires should be on the opposite side of the road to the cables, and, in any case, should be so fixed that falls of roof, or falls of the wires or cables themselves, should not bring the two into contact. In the author's opinion, some of the accidents that have taken place where men have received shocks from touching signal wires are due to a want of this precaution.

Shaft Signals

Shaft signals are used for signalling from the bottom to the bank and to the engine-house, from the engine-house and the bank to the bottom, and from the bank to the engine-house. The usual arrangement is, a powerful single stroke bell is fixed at each pit bottom, one on the bank for each pit bottom, and one in the engine-house for each pit bottom. Covered copper wires, which are sometimes as small as No. 18, but which should never be less than No. 16, and would be better if No. 14, connect the bells with the batteries, and with the arrangements for completing the circuit. There may be one or two batteries. The author prefers two, one to furnish current for the up signals, this battery being fixed at each pit bottom, and the other to furnish current for the down signals and those between the bank and engine-house, this being fixed on the surface. His reason is that the covered wires in the shaft are the most difficult to maintain, and the

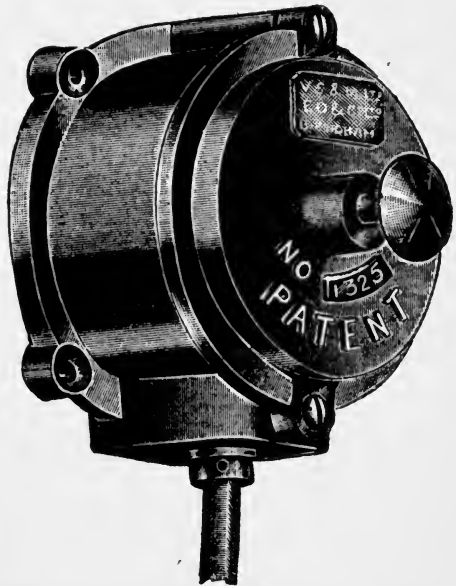

FIG. 13.—Iron-cased Ringing-key for Shaft Signals made by the Electric Ordnance Co.

wire carrying the current from the surface to the pit bottom is always very much more difficult to maintain, very much more liable to electrolytic action, than those in which the current only passes when a signal is given. The connections for this are shown in Fig. 12. The ringing apparatus, or "pushers," as mining men term them, are

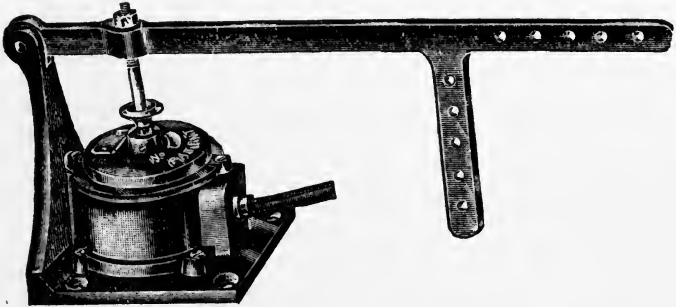

FIG. 14.—Ringing-key, shown in Fig. 13, arranged to be worked by a Lever and Rope instead of by the Band.

now nearly always of the plunger form. A lever or spring is enclosed inside an iron dome-shaped box, fitted so as to be perfectly water-tight, and from the top of the dome a short cylinder projects, carrying a plunger, ending in a substantial wooden or vulcanized knob, the plunger being kept out of contact with the lever or spring by a stout spiral spring surrounding it. The circuit is completed by pushing the plunger inwards, and bringing the spring with its contact piece, or the lever, into connection with the contact piece provided for it. A form of ringing-key is shown in Fig. 13, to be worked by hand, in Fig. 14

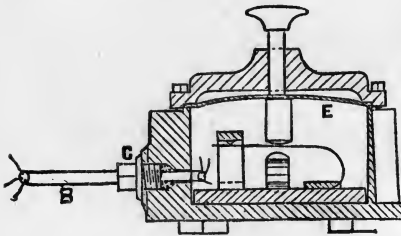

FIG. 15.—Section of the Ringing-key shown in Figs. 13 and 14. *B* is a Triple Wire; *C* a Gland through which it passes; *E* the Case.

to be worked by a lever, and a section is shown in Fig. 15. Even with the very best fitting, there is considerable difficulty in preventing water, which is nearly always present at pit bottoms, in the positions where the ringing-keys have to be fixed, from creeping into the contact-box. The author prefers to have the terminals to which the wires leading to the battery and the bell are to be connected outside of the contact-box, so that any electrolytic

or electro-chemical action may be seen, and the oxide and copper which is formed cleaned off periodically.

If the author's suggestion is adopted, and motor generators are employed to furnish current for the signals, the current for the up signal can be taken from a motor-generator at the pit bottom, and that for the down signals from one on the bank, or the same arrangement can be made with accumulators.

Bells for Mining Signals

Bells for mining signals are of two forms, those that are intended to be used in explosive atmospheres, and those that are to be used in ordinary atmosphere. The author has made a good many experiments to determine whether it is possible for the spark which passes between the contacts in a trembler-bell to ignite an explosive mixture, and the conclusion he came to was that it was not. He understands, however, that others have succeeded in igniting an explosive mixture by means of the

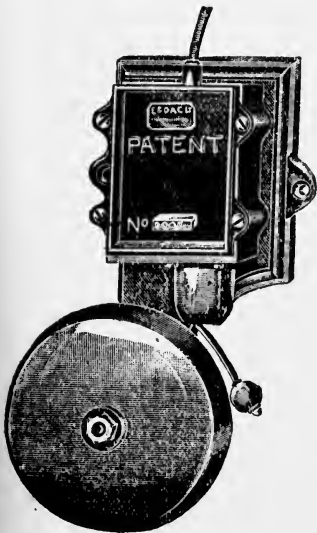

FIG. 16.—Gas-proof Iron-cased Trembler-bell, for Mining Signals, made by the Electric Ordnance Co.

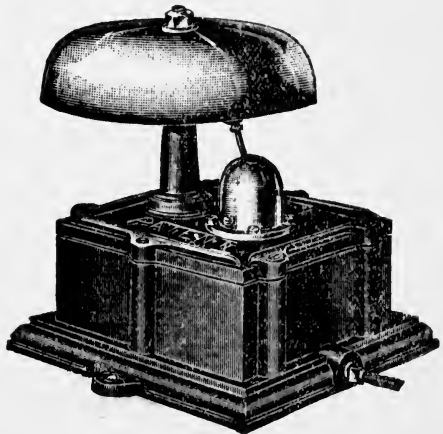

FIG. 17.—Single-stroke Iron-cased Damp and Gas-proof Mining Bell, made by the Electric Ordnance Co.

spark mentioned, and as one positive experiment of this kind is of more importance than a thousand negative ones, he proposes to describe what has been done to meet the case. Briefly, what has been done is to enclose the trembling contact of the trembler-bell inside a gas-proof case, and to cause the armature of the bell to

transmit the trembling action to the hammer-rod which strikes the bell, by means of a mechanical arrangement, acting through a metallic diaphragm. One of these arrangements is shown in Fig. 16. The construction of bells for mining work should be very strong. The electro-magnets should be very powerful, and the whole thing should be so arranged that the bell will go on working, though the battery has run down to a certain extent. Further, bells which are intended for mining work, and particularly those for metalliferous mines, should have their electro-magnetic apparatus enclosed inside of damp-proof cases, the motion of the hammer-shaft being delivered to it in such a manner that the damp-proof arrangement will not be broken. Fig. 17 shows a single-stroke bell, embodying this.

Relays for Mining Signals

The relay is a well-known device used by telegraph and telephone engineers, and its office is to enable a very weak current arriving, say,

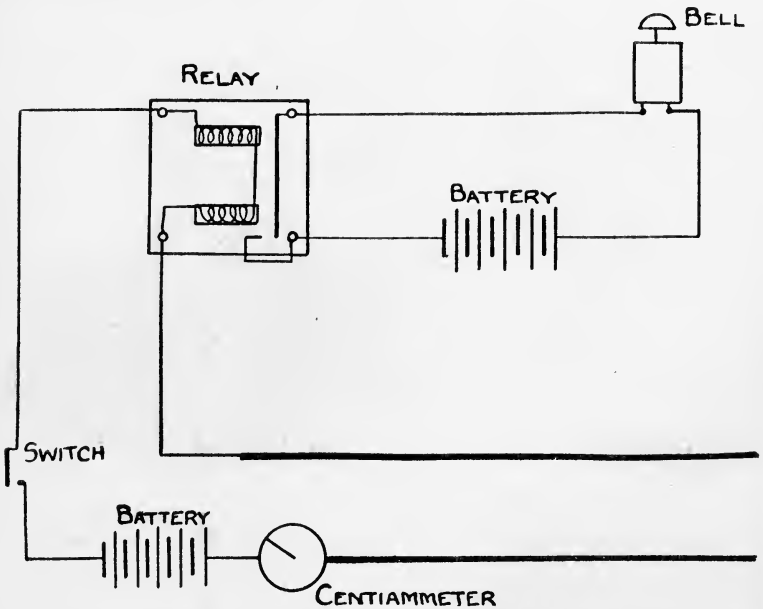

FIG. 18.—Diagram of the Connections of a Two-wire Engine-road Signal, with Relay, two Batteries, Switch, and Centiammeter.

from a distant station over a badly insulated line, to actuate a battery of sufficient power to operate an apparatus that will give strong, clear

signals. The device is employed in some forms of wireless telegraphy, the electric waves causing a circuit in which a very weak current is passing to be completed, and to operate a relay which actuates a circuit containing a powerful battery and printing apparatus. The relay was introduced into mining signal work by the author some twenty-five years ago, to meet a case where he was obliged to use very weak currents, owing to the fact that the long engine road upon which the signals were working was very wet, and it was impossible to maintain the insulation. The only method of keeping the signals going was by using a very weak battery, and causing it to actuate a relay which brought a powerful battery into operation, completing a circuit in which the bell to be worked was included, the latter giving a loud, clear sound. The connections for this are shown in Fig. 18. The relay has since been employed for other similar work, as, for instance, for ringing each bell of a number of bells on an endless rope engine road by means of its own battery, fixed locally; and, as explained, it has been made the base of Mr. Willis's ingenious apparatus for indicating signals on endless rope engine roads. The remarks made in connection with electric bells for mining signalling generally apply to relays. The relay is a very much smaller apparatus than either the signal stroke or trembler-bell, but its electro-magnet should be made fairly powerful for the work it is intended to do, and it should be enclosed in a damp-proof and gas-proof case. One form is shown in Fig. 19.

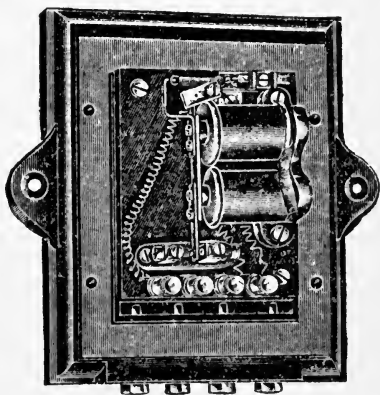

FIG. 19.—Relay enclosed in Iron Case, for Mining Work.

Telephones for Mines

For communicating between different mines and works under the same management, and between the different parts of the same works, perhaps the simplest method, when the establishment is large enough, is that of the telephone exchange. At each mine wires are brought from each point between which it is required to communicate, to sub-centres, wires are taken from the sub-centres to centres, and wires again connect the centres at the different mines. At each sub-centre there is a simple telephone switchboard, consisting of a

number of electro-magnets, each having its own shutter, which drops and discloses its number when a call is made, and a system of connecting arrangements, either by plugs arranged to connect any one of a number of vertical bars to any one of a number of horizontal bars, or by what are termed "jacks," consisting of vulcanite plugs with connecting pieces, the plugs being forced into certain holes under the indicating electro-magnets, making connection between the ends of the coils of the electro-magnets and wires concealed in a cord attached to the "jack." At the other end of the cord there is another "jack," and when connection is required between any two numbers of the sub-centre, one "jack" is inserted under the indicator of the calling number, and the other "jack" is pushed in under the indicator of the number wanted. The wire leading to the centre has its own indicator, similar to those of the numbers of the sub-centre, and when connection is required with a number in another sub-centre, the centre is called, connection is made with it, the centre calls the sub-centre where the number wanted is, the second sub-centre calls its number, makes connection with it, signals the centre, which signals the first sub-centre, and connection is complete. Arrangements are made by ringing a bell, or in other ways, to advise the sub-centre and the centre when communication is finished. This arrangement can be carried almost as far as the management choose. The only point in connection with it that has to be considered is, each switchboard requires attention, but as one sub-centre might be in the weigh cabin at the pit top, the weigher might easily attend to it, and one of the clerks in the central office could easily attend to the centre switchboard. Automatic exchanges are on the market, and are said to be doing good work in America; but, so far, they do not appear to have made any headway in this country, and the author fears that the apparatus would be too delicate for use about coal mines. In the automatic apparatus each telephone station has its number, and the user signals his number to the sub-centre or the centre by turning a lever to certain numbers in succession, and a succession of electro-magnets perform the operation of making successive connections, just as the attendants of a telephone exchange would.

Telephone exchanges about mines are conveniently worked by batteries of dry cells, but they also might be worked by means of motor generators, giving low pressure currents, or from accumulators.

Intercommunication Telephone Apparatus.—Where the number of telephone stations is not large, and there is no convenience for sub-centres, the intercommunication telephonic system is very convenient. By this arrangement each station has its own telephone set, consisting of transmitter, receiver, switches, etc., and in addition, it has a multiple switch, the number of contacts on which are as

many as the number of stations that can be connected on the system. Each station has its own number, and communicates with any other station by turning a switch handle to the number of the station it wishes to speak to, calling and talking then in the usual way. Some trouble arises in intercommunication sets if the switch handle is not returned to 0, which is the receiving number for all the stations. When the station is not receiving a message, the switch handle should be in the position for calling. With some systems the difficulty has been overcome by the switch handle being automatically brought back to the calling position when the telephone receiver is replaced on its hook. In other cases, as with the Ericsson and the Berliner, special arrangements are made, so that, notwithstanding a switch may be left, say, on No. 6 at No. 10 station, if any other station calls No. 10, the call will reach No. 10's bell, and communication can be entered into. Another difficulty which arises in some cases in connection with the intercommunication system is, if one wire is used as a common return, all of the stations can, if they choose, hear any message that is being sent between any two stations. This has been overcome in the case of the two firms mentioned, by using complete metallic circuits, and by doubling the switching arrangement. With one common return wire there must be the same number of wires leading to all the stations as there are stations, plus two, the wires for the battery and return. That is to say, if there are twenty stations, there must be twenty-two wires leading into each station. This was a little formidable at first, but the difficulty has been overcome by making up cables with the required number of wires, each properly insulated, and the whole being inside an outer braid, the complete cable not being larger than an electric light cable, for a comparatively small number of lamps. For junctions with the intercommunication system, junction boxes have been devised which simplify the matter very much. The wires enter the boxes, and are connected to terminals from which the wires leading to the station are also taken, or from smaller terminals connected to the first terminals, the whole being enclosed in a wood or iron case.

Telephonic Communication on Engine Roads

This is perhaps the most useful application of the telephone about a mine, and it is applied in a very simple manner. The usual arrangement is, an ordinary telephone transmitter and receiver is fixed in the engine-house, and is connected to the engine-road signal, a switch being provided to reduce the battery power passing in the microphone when the telephone is in use, this being necessary, and the regular telephone switch keeping the apparatus disconnected

from the engine-road wires when not in use. The equipment for the engine road is merely one or two watch telephones with their cords, and clips, to enable them to be hooked on the signal wires. One difficulty in connection with this arrangement is, the man who uses the telephone on the engine road has no means of knowing that he



FIG. 20.—Simple Telephonic Apparatus for Use in Mines, consisting of Microphone Transmitter, Telephone Receiver, and Switch, the Telephone Cord and the Receiver being protected by a wrapping of Brass Tubes.

has been heard, except by keeping a telephone to his ear, and listening to what is taking place at the instrument in the engine-house. If the engine-man is busy, and he cannot attend to the call, which is made by rapping a certain number of times on the signal-bell, it becomes very tedious and tiring for the road-man to hold the telephone at his ear. The author suggests that a simple apparatus, consisting of a couple of small dry cells, a small bell, switches, etc., made up in a convenient form, and carried in a leather case, might be used by the road men, and when they wished to communicate they might signal the number of raps, and in place of

keeping the telephone to their ear, hook their apparatus and the wires and wait till the engine-man signalled. The apparatus would not be expensive, and it would be very convenient. A handy form of telephonic apparatus for use in mines is shown in Fig. 16.

Wireless Telegraphy for Mines

Wireless telegraphy cannot be used for communicating with the underground workings, and it is very doubtful whether much advantage would be gained by its use for communicating between mines situated at a distance, though the author has been informed

that a manufacturer in Yorkshire communicated with the works from his house by wireless telegraphy. Wireless apparatus is all very delicate, and it writes Morse characters, while the telephone can be used by any one, and speaks the language of whoever is using it. In addition, the Government have claimed a monopoly of its use.

Shot Firing by Electricity

By shot firing is meant the ignition of the charges of explosives employed to force the mineral down clear of the other strata, as will be explained in connection with coal cutting and drilling in Chapter VI. Every explosive, and in fact every substance, has a certain ignition temperature, and to ignite the explosive a small portion of it has to be raised to the ignition temperature, the heat generated in the burning of this portion being sufficient to ignite the rest, rapid combustion and what we call explosion, very rapid expansion of the gases formed by the combustion of the explosive, following. With electric ignition the required increase of temperature is produced by the ignition of a small quantity of a specially sensitive substance, fulminate of mercury being the one most commonly employed, which is itself raised to its ignition temperature by the heat liberated either in a small platinum wire, or by a spark. Electric fuses, as they are called, consist of small quantities of one of the substances mentioned, in which is embedded either a small platinum wire, as described, or the ends of two copper wires. In either case the fuse and wires are enclosed inside a copper cap, for protection, and the ends of the wires are brought down to insulated connecting wires, which are sometimes fixed in grooves in a stick, to one end of which the fuse is attached, the stick being of the length of the shot hole. The connecting wires in any case must be long enough to allow the fuse to be pushed right up against the end of the charge of explosive, to extend to the mouth of the shot hole, and to leave sufficient length for connecting to the source of current. The fuses in which the small platinum wire is embedded, are known as low tension fuses, and the source of current required to raise them to the temperature necessary to fire the fuse, is provided from a source of electricity of low tension, but that will furnish a comparatively large current, the current being 0.3 amperes for each fuse, while the pressure need only be a few volts. The current for low tension fuses is generally supplied by a battery of either dry cells, or accumulators. The latter are more reliable, providing that care is taken before carrying them down the pit, to see that they are properly charged. They require recharging from time to time, and it must be remembered that if the firing accumulator battery is not used for some time, it

must still be charged as often as the pressure falls to 1·8 volts per cell. It is a good plan to give them a charge every day.

The fuses in which the heat is generated by the passage of a spark are known as high tension fuses, and the pressure required may vary considerably, though in modern fuses the results are much more uniform than in those of twenty years ago. The lengths of the wires protruding into the detonator, their distance apart, and other conditions alter the pressure necessary to drive a spark across the gap between them. It may be taken, however, that a pressure of 50 volts should be available, and it is all the better if the available pressure is 100 volts. The source of current with high tension fuses is usually a magneto-generator, a small dynamo machine fitted with permanent steel magnets, and with what is known as a shuttle armature; an armature something of the shuttle form, a long coil of wire being wound in the space where the thread would be wound in weaving, the ends of the coil of wire being connected, usually, one to the mass of the shuttle itself, and the other to an insulated contact on the end of the spindle to which the shuttle is attached, and on which it revolves, the contact bearing against a spring carried inside the case for the purpose. In some forms of apparatus a small condenser, consisting of leaves of tinfoil, separated by paraffin paper, and enclosed between two metal plates, is added to increase the pressure of the firing current. In any case the whole is enclosed inside a mahogany or teak box, with a leather strap for carrying, and with a handle arranged to fit on the axle of the armature, the latter projecting through a hole in the case provided for the purpose. There is usually also a push fixed on the side of the case, convenient to the hand of the shot firer, which breaks the connection between two springs, arranged to short circuit the coils. A pair of terminals for the wires to connect the apparatus to the fuses completes the equipment. When shots are to be fired, the charges are placed in the shot holes, the fuses placed in the shot holes, and tamping put in to fill up the hole, this last being preferably formed of wet grass or some material that will extinguish the flame if the shot blows outwards, instead of expending its energy in bringing down the mineral. Wires are then taken from the fuses from the neighbourhood of the firing battery, using the term to mean the battery of cells for the low tension fuses, or the small dynamo machine. The cable is preferably made up as a twin cable, two wires separately insulated laid up together and insulated overall, as it is more convenient to handle, the cable being coiled on a drum provided for the purpose, and placed on the ground in the neighbourhood of the firing battery. Both wires of the cable should be well insulated. The firing battery should be placed well out of the range of the effects of a possible blown-out shot, and of all accidents. The cable should never on any account be connected to the firing battery,

until it has first been connected to the fuses, and it has been ascertained that it is clear of everything between the drum and the fuses, and that everybody is out of the way. When this has been ascertained, the inner ends of the two wires on the drum are connected to the terminals of the firing battery, and if it is a low tension battery, a push or contact key is pressed, this completing the circuit between the battery and the fuses. If it is a magneto-exploder, the handle is fixed on the armature, the shuttle is turned rapidly until it has got up a good speed, and the push is then pressed.

The fuses may be either in series or in parallel. Series means the same thing as is shown in Fig. 1, p. 7, one end of the connecting wire being connected to one wire of the end fuse, the other end of the connecting wire to one wire of the fuse at the other end of the row, and the circuit being completed by connecting adjacent wires of the intermediate fuses together, the current in this case passing through the fuses in succession. This arrangement has the disadvantage that the pressure furnished by the firing battery must be sufficient for the whole number of fuses. That is to say, if each fuse takes as much as 50 volts, and there are six shots to be fired, the firing battery must furnish 300 volts. It also has the disadvantage that if one of the fuses, as sometimes happens, fires slightly before the others, it breaks the circuit, and no current can pass to the remainder.

The parallel system is the same as shown in Fig. 2, p. 7, each fuse being connected between the two connecting wires, and the current passing simultaneously to all of them. With this arrangement it is necessary that the current furnished shall be sufficient for the whole number of the fuses. Thus, if each fuse takes 0.3 ampères, the battery must furnish 1.8 ampères for six fuses. It is also necessary that the resistance of the individual fuses should be very nearly alike. If the resistance of one fuse is appreciably lower than the rest, the current passing through that fuse may lower the pressure delivered to the others so much that sufficient current does not pass through them to ignite them. *Per contra*, if one of the fuses is of very much higher resistance than the remainder, it may not obtain sufficient current.

In practice it is usual to fire high tension fuses in series, and low tension fuses in parallel, though in the author's opinion the reverse arrangement would be more satisfactory.

Frictional Electrical Firing Apparatus

There is another apparatus that is still used occasionally for shot firing, but which is gradually going out, as the magneto-exploder and the accumulator and dry cell become more perfect, viz. the frictional

electrical apparatus. In the latest form of this apparatus an ebonite disc is rapidly revolved, either between rubbing pads of silk covered with an amalgam of mercury, in which case a high electrical pressure is generated directly by the friction, or in what is known as an electrostatic induction machine, in which there are two ebonite discs, to one of which a small charge is communicated by touching it with the finger, the other then commencing to generate a pressure which gradually increases as the speed increases, and which may be of very considerable voltage. The frictional electrical exploder furnishes sufficient pressure to explode a comparatively large number of high tension fuses, and is therefore still rather a favourite where a large number of shots are fired together, as in sinking, and where a large quantity of mineral is got down at one operation in one place. The great objection to frictional apparatus is its great sensitiveness to the presence of moisture and dust. If the ebonite discs become covered with a very thin layer of moisture, as they are almost sure to do anywhere in a coal mine, and if, as would naturally follow, a deposit of coal dust takes place upon the discs, the apparatus is rendered useless. For surface work, however, where the apparatus can be kept dry and clean, and where it is in the hands of a man who does not mind taking a considerable amount of trouble to keep it so, the apparatus will do good service.

CHAPTER III

ELECTRIC LIGHTING FOR MINES

THERE are three kinds of electric lamps that are applicable for use in mines, the arc lamp, the incandescent lamp, and the Nernst lamp, the latter occupying a position between the arc and the incandescent lamps.

Arc Lamps

There are, again, three forms of arc lamps in use, all of which can be made to do good service in and about both coal and metalliferous mines, viz. the Open Arc, the Enclosed Arc, and the Flame Arc. All three lamps are made also for use with both continuous and alternating currents, though the light furnished by the arc lamp, when used with alternating currents, as will be explained, is different to that when using continuous currents.

The enclosed arc lamp is, perhaps, the best all-round arc lamp for use in and about mines, principally because it is simpler in construction, and because it burns longer without attention. All arc lamps, except the flame lamps, and some even of those, are arranged upon the same general lines. There are in nearly every case two carbons arranged vertically one above the other, the upper carbon being always the positive, or the carbon from which the current passes into the arc. In all forms of arc lamps except those known as shunt lamps, and the majority of the flame lamps, the upper carbon rests upon the lower carbon when no current is passing, and the lamp is not burning. When current is switched on, the mechanism of the lamp separates the carbons by a very small distance, $\frac{3}{32}$ inch in the case of the open arc, and from $\frac{3}{8}$ inch upwards in the case of the enclosed arc, the current then jumping the space between the carbons and "striking the arc," as it is termed. If the pressure of the current is sufficient to maintain the arc between the ends of the carbon rods, the lamp continues to burn, and it burns as long as these conditions rule. As the lamp burns, the carbons waste

away, partly by oxidation in the intense heat produced by the arc, about 5000° C., but more by the conversion of the positive carbon into vapour. As the carbons waste, they must either be fed towards each other, the pressure must be increased in proportion to the increased distance between the carbons, or the lamps must go out. In practical arc lamps the method adopted is, when a certain portion of carbon has wasted, and the arc is therefore longer by a certain amount, a very small fraction of an inch in the case of a well-constructed and well-regulated open arc lamp, the mechanism of the lamp causes either the upper carbon to approach the lower one by a small fraction of an inch, making up the amount that has been wasted, and possibly a little more, or both carbons slightly approach each other. A wink may easily be seen when the lamp feeds, as it is termed, even with the best forms of lamp, and for that reason, when very good illumination is required, many more arc lamps should be provided than would be necessary to furnish the light required, in order that the winking of the individual lamps may be masked. For colliery sidings, pit heaps, even pit bottoms, where arc lamps can be employed, the matter of the wink when the lamp feeds is of very little consequence, providing it burns continuously. In the enclosed lamp, as already indicated, the arc is very much longer than with the open lamp. In addition, the carbons burn in a different form. In the open arc with continuous current, the negative carbon burns to a sharp point, with some bubbles of incandescent carbon usually visible at different parts. The positive carbon burns also almost to a point, but right at the end the point is blunted, and there is a small depression known as the crater. It is in the crater where the conversion of the positive carbon into vapour takes place, and where the largest part of the current employed in the arc lamp is converted into heat. The crater also performs the very useful office of reflector. When the lamp is burning, the little area of the surface of the crater is at an intense white heat, and with the continuous current lamp the rays emitted are thrown directly downwards. In the enclosed arc lamp the carbons burn, both of them, almost flat. In addition, the carbons waste very much more slowly than in the open arc, the principal reason being, as explained below, that oxidation is almost entirely suppressed within a few minutes of the lamp being switched on. The result of burning the longer arc, which may be even as long as an inch or more, though it then assumes a very distinctly violet hue, and the slow wastage of the carbons, is that the feeding of the lamp is very much less frequent than with the open arc, and, further, it is not so noticeable. With the open arc the light rays are very much confined, owing to the closeness of the carbons together, and therefore the feed is very apparent.

The Mechanism of Arc Lamps

The mechanism of the enclosed arc lamp is simpler, as already explained, than the open arc lamp, for the reasons given, because the wastage of the carbon is less and because the arc is longer. It is always easier to maintain a long arc when there is sufficient pressure, and the other conditions are suitable, than a short arc, because there is

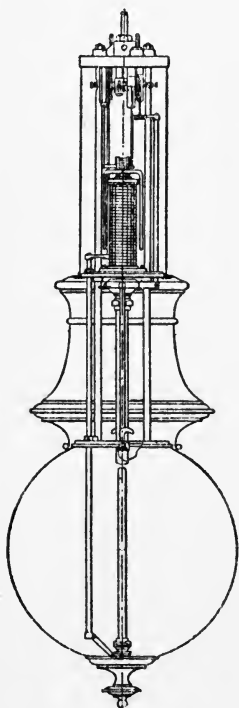

FIG. 21.—Section of the Brockie-Pell Single-carbon Arc Lamp, as made by Messrs. Johnson & Phillips, showing the Mechanism.

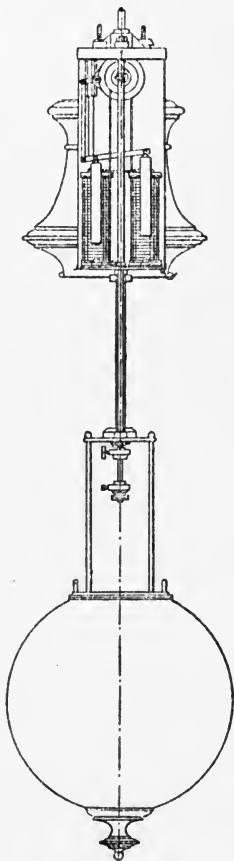

FIG. 22.—A Section of the Lamp shown in Fig. 21, but from a Point of View at Right Angles. The two Solenoids are shown and their Cores, with the Brake-wheel above. The Globe is lowered for Recarboning.

more room to play with. The mechanism of open arc lamps runs on a few lines, the brake mechanism first introduced in the Brockie-Pell

lamp a good many years back being the favourite. In this mechanism, one form of which is shown in Figs. 21 and 22, which is applied only to continuous current open arcs, the upper carbon, and sometimes both carbons, are suspended from a band, chain, or cord. It is a very common practice in this form of lamp to make the lamp focussing, by raising or lowering the lower carbon holder at the same time as the upper carbon holder is lowered or raised, the arc remaining in practically the same position with reference to the outer globe. The cord, or chain, or band passes round a wheel supported above the platform upon which the remainder of the mechanism of the lamp is fixed, and when it only supports the upper carbon, the end of the chain or cord is attached to the upper carbon holder. When both carbons move, the other end of the chain or cord is taken round a pulley at the bottom of the lamp, and is then attached to the lower carbon holder. When the carbons are placed in the lamp the cord or chain is wound up on its pulley, and as the carbons waste away, the cord or chain is gradually unwound, the upper carbon being gradually allowed to move towards the lower carbon, or the two carbons being allowed to move towards each other. The wheel upon which the cord or chain is wound is controlled by various methods, by a second wheel, by a sector and ratchet, by a lever, and other arrangements; the controlling apparatus is worked usually by the cores of two solenoids, one of which has its coils in series with the arc, and is termed the main magnet, the other having its coils in parallel, or, as it is termed, in shunt with the arc. The coils of the main solenoid must be of sufficient sized copper wire to accommodate the largest current the lamp can be called upon to burn with. The shunt magnet is wound with very fine wire. In some forms the shunt is merely bridged across the arc. That is to say, one end of the shunt coils would be connected to the positive carbon holder, and the other end to the negative carbon holder; but in the great majority of cases the shunt coils are bridged across the terminals of the lamp, and have the benefit of the pressure across the main solenoid coils as well as across the arc. When the current is switched on to the lamp, the main magnet turns the wheel in one direction, separating the carbons to a given definite distance, regulated by screws provided for the purpose. Before the arc commences to burn, the shunt coil has practically no current. When the arc has been struck, the shunt coil has a current passing through it, exactly in proportion to Ohm's law. Taking the pressure across the terminals of a lamp as 50 volts, the resistance of the shunt coil will be from 750 ohms upwards, and the current passing through its coils will then be one-fifteenth of an ohm. As the arc increases by the wastage of the carbons, the current passing through the shunt coils gradually increases, the pull of the shunt solenoid upon its core

gradually increases, while the current in the series coils being gradually lessened by the lengthening of the arc, the pull of the series solenoid upon its core gradually weakens, and at a certain point the pull of the shunt overcomes that of the series, and the brake-wheel is allowed to revolve a small distance, the carbons moving that distance towards each other, and this takes place at every feed. In the Luna arc lamp, made by the Electrical Company, the carbon holders are supported by a chain passing over a sprocket wheel which runs between two plates, which are hinged at their lower end, and have an armature attached to the upper end. The sprocket wheel is connected by spur gearing with a train of wheels, the last of which is a star-escape wheel that engages with a steel pallet fixed on the frame of the lamp. When the star wheel is locked by the steel pallet, the lamp cannot feed, and the office of the shunt magnet in this lamp is to release the wheel train, the weight of the carbons then causing the wheels to run, the carbons to approach each other, until the shunt again loses its power and the train is locked. The Luna lamp is one of the few that is made either as a purely shunt lamp, or as a series and shunt, or differential lamp, as it is usual to term them. In the purely shunt lamp there is no main magnet, its place being taken by a spring which opposes the pull of the shunt magnet. When the lamp is not burning, the carbons are separated by what will be the length of the arc when burning, and the first effect of the current is, the shunt being of sufficient power, the arc being open, to overcome the pull of the spiral spring. The wheel train is unlocked, the carbons run together, the shunt magnet then loses its current entirely, the spiral spring separates the carbons, striking the arc, and the shunt comes into operation again when the arc is sufficiently long to require a feed. The office of the series magnet in the Luna and other differential lamps is to separate the carbons, which are together when the lamp is not burning, in the same manner as the spiral spring does.

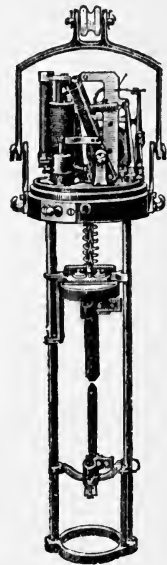

FIG. 23.—Showing the Mechanism of one of the Union Electrical Co.'s Open Arc Lamps.

The Krieg and Methiessen Lamps.—Fig. 23 shows an open arc lamp of this firm's make. In these lamps, which are supplied by the Union Electrical Co., a train of wheels is also employed, something on the same lines as the Luna. The lamps are made for shunt and differential, just as the Luna are, the shunt being opposed by a spring which strikes the arc when the lamp is first turned on. In some forms of this lamp

there is a heat compensator, which, it is claimed, prevents the arc increasing beyond a certain amount, by increasing the resistance of the coils. The open arc lamp is made to burn as much as twenty hours with single carbons, and as much as forty hours with double carbons.

The Enclosed Arc Lamps.—

The principal feature of the enclosed arc lamp is the fact that its carbons burn in an enclosure consisting of

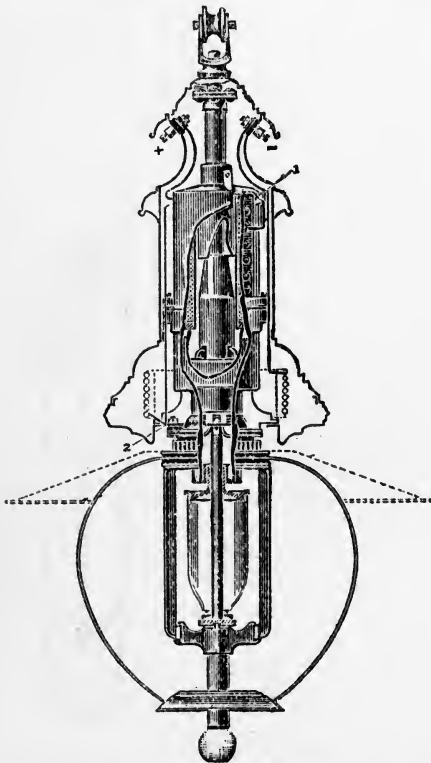

FIG. 24.—Showing the Mechanism of the "Jandus" Enclosed Arc Lamp, with its Special Form of Electro-magnet.

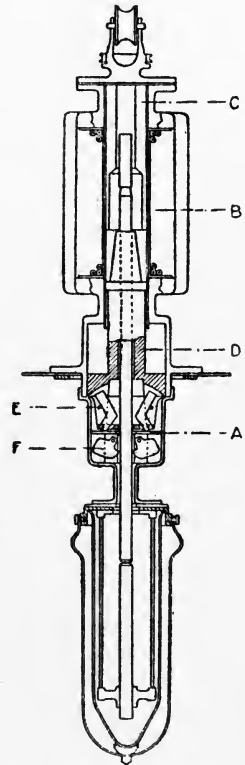

FIG. 25.—Messrs. Johnson & Phillips' "Ark" Enclosed Arc Lamp. *A* is the Contact Frame for the Upper Carbon Rod, *B* is the Solenoid Electro-magnet, *C* is a Stationary Portion of the Iron Core of the Solenoid, *D* is the Moving Portion of the Iron Core, *E* are Pins connecting it to the Clutch Cams, which grip the Upper Carbon, *F* are the Contact Pieces through which the Current passes.

a globe, so arranged that when the lamp is started, the heat liberated by the arc drives the air out of the enclosing globe through a valve provided for the purpose, the remainder of the

burning taking place in an atmosphere consisting almost entirely of carbonic oxide gas. It is this atmosphere which lessens the waste of the carbons by reducing the oxidation almost to *nil*. As explained, also, it enables the arc to be very much longer. The carbons employed must be very pure, otherwise chemical actions will be set up that will practically neutralize a large portion of the effect produced by enclosing the arc. It will not do, for instance, to use the ordinary carbons made for open arc lamps in enclosed lamps. The mechanism of the enclosed lamp

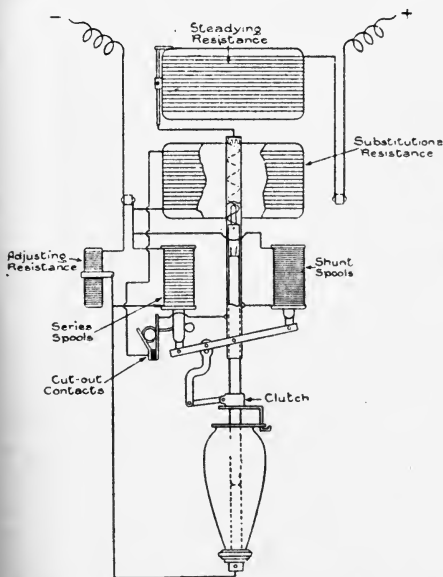

FIG. 26.—Diagram of Arrangement of B. T. H. Co.'s Enclosed Arc Lamp, showing the Mechanism, Cut-out, Steadying and Adjusting, and Substitutional Resistance.

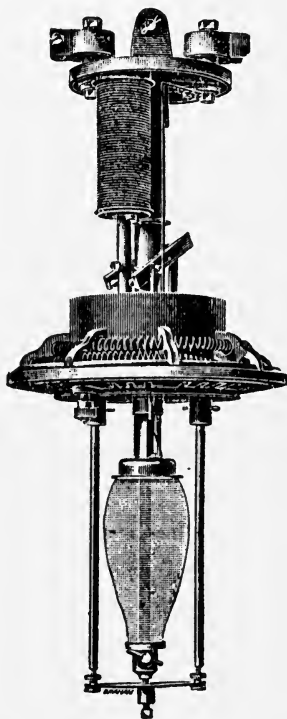

FIG. 27.—View of "Angold" Single-carbon Enclosed Arc Lamp, showing the Mechanism and Adjustable Resistance.

consists, in the simplest forms of lamp, of a solenoid in series with the arc, the pull of the solenoid being opposed by a spring, and actuating some simple form of clutch. The pressure absorbed by the enclosed arc lamp is from 80 volts upwards, and a resistance is usually enclosed in the lamp case, enabling the lamp to be run directly on services of as high as 260 volts.

Two forms of enclosed arc lamps demand attention, the Jandus, shown in Fig. 24, in which there is a compound solenoid, and the

Johnson and Phillips' enclosed arc lamp, shown in Fig. 25, in which there is also a special form of electro-magnet. In the "Ark" lamp, which is the name given by Messrs. Johnson and Phillips to their enclosed lamp, the upper carbon holder is dispensed with, the arc-striking mechanism and the feed mechanism acting directly upon the upper carbon itself. The upper carbon is gripped, when the current is switched on to the lamp, by four clutch cams contained in a box, through the centre of which the upper carbon passes, the cams being actuated by a solenoid of a special form in the lamp case above. In addition to this, there are four contact pieces, which are also pulled into contact with the upper carbon holder when the arc is struck, and it is therefore through these that the connection is made to the upper carbon. Figs. 26, 27, and 28 show other forms of enclosed arc lamps.



FIG. 28. — The Union Electrical Co.'s Differential Enclosed Arc Lamp.

The Lower Carbon Holder.—In all forms of arc lamp the lower carbon is carried in a holder, either held at the bottom of a rectangular frame depending from the box in which the lamp mechanism is carried, or it is held in the bottom member of the frame supporting the gallery below, and also the globe. The gallery supporting the globes is sometimes made to lower, leaving the carbon holder in position so that the lamp can be trimmed; and in other cases other arrangements are made.

Double Carbon Arc Lamps.—Both open and enclosed arc lamps are made by some firms to burn two carbons, the object being to give a long period without changing the carbons. The early Brush arc lamps, it will be remembered, were double-carbon lamps, and the arrangement employed to-day is very similar to that employed in the Brush lamp of twenty-five years ago. In the double-carbon lamp the two sets of carbons are held vertically, as in the single-carbon lamp, the positive carbons resting upon the negatives.

The arc is struck by the same mechanism between each pair of carbons, and the feeding mechanism is also the same; that is to say, there is one main solenoid, one shunt solenoid, and so on. It is in the clutch that the double action is usually arranged. When the two pairs of carbons are both in contact, there are two paths for the current, but if one pair is separated, there remains only one path for the current. When the current is switched on, the arc-striking mechanism first separates one pair of carbons, and then strikes the arc between the other pair. If the carbons that are burning stick,

or burn too long an arc, the second pair come into service, the arc being formed between them until the first pair right themselves. The usual arrangement for substituting the second pair of carbons when the first pair is burned out is, the first pair are prevented from feeding onwards after the carbons have burned to a certain length by a stop provided for the purpose, and the current then ceases to pass through them, and is automatically switched on to the other pair.

Figs. 29 and 30 show double-carbon arc lamps.

Dash-Pots.—In all arc lamps dash-pots play an important part. They are practically buffers, and are intended to reduce the sometimes quick action of the feeding mechanism. A favourite form of dash-pot is a brass cylinder with a piston moving inside it; and it is arranged that when the arc is to feed, the mechanism has to compress the air in the cylinder before it can do so, this tending to make the feed a little less quick, and to give a better regulation to the lamp, a more steady feed.

Twin Arc Lamps.—This is a form of double arc lamp which has been introduced since the supply pressures in most towns has been increased to 200 volts and upwards. It consists of two separate sets of carbons through which the current passes in series, so that the whole of the double pressure is used up. The twin arc lamps are more commonly employed with enclosed lamps than with open arcs, as the pressure of the enclosed lamp with two arcs practically uses up the pressure of the service.

Small Arc Lamps.—Nearly all the makers of arc lamps now make very small lamps under various names, such as the "Midget," that may be of service in certain parts of a mine, such as the engine-house, the heapstead, fitting shops, large pumping-houses, etc. They are made to take very small currents, but with the same pressure as with the larger forms of arc lamps, and they give very much less light in proportion to the larger lamps. They are made in various forms for currents from 1 ampère to 3 ampères, and for open and enclosed arcs.

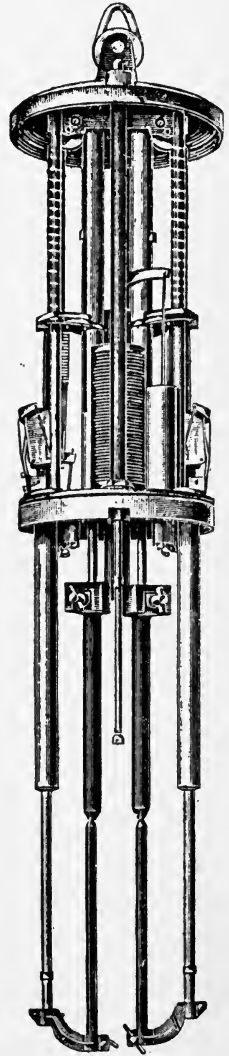

FIG. 29.—"Angold"
Open-type Double-
carbon Arc Lamp.

Alternating Current Arc Lamps

The alternating current arc lamp is similar in a great many respects to the continuous current lamp, but the light given in the case of all but the flame arc lamps with converging carbons is different. In all alternating current arc lamps with carbons arranged vertically one above the other, both carbons are partially pointed, both have their points partly blunted, and both have small craters, approximately half the size of the crater formed in the positive carbon with continuous current lamps. The reason is, both carbons are alternately positive and negative. The result is that in place of, as in the continuous current arc, the light being thrown downwards from a line 30° from the vertical line passing through the arc, part of the light is thrown upwards, and part downwards. The carbon holder and frame, etc., below the arc stop the light immediately below, and the case containing the lamp mechanism stops it above, and the result is that there are two lighted areas with the enclosed arc lamp, extending approximately from a line about 15° from the horizontal to 30° from the vertical above and below the arc, while with a continuous current the light only extends over that area below the arc. The arc lamp mechanism is specially constructed for working with alternating currents, the important feature being the cores of the electro-magnets, and any moving iron that takes part in the action of the lamp, which are very carefully laminated; that is, they are split up into a number of thin plates, and, where possible, of wires. The alternate current arc lamp burns with a much lower pressure than the continuous current. It is usual to allow 50 volts per lamp for continuous current lamps, where about 38 volts is sufficient with alternating current lamps.

Flame Arc Lamps

The flame arc lamp is a recent introduction, and its special feature is the colour of the light furnished by the lamp, and the peculiar flame with which it burns. In the great majority of cases, also, the lamp is made with its carbons suspended from the case containing the lamp mechanism, the two carbons being slightly inclined to the vertical and to each other. The Electrical Co., however, make a flame arc lamp in which the carbons are suspended vertically one above the other, as in the ordinary lamp, as well as the type with converging carbons. The colour of the light is due to the carbons, in the course of preparation, having been impregnated with salts of sodium, calcium, and strontium. Carbon rods for use in arc lamps are made by grinding up charcoal and the purest forms of carbon

obtainable to a very fine powder, kneading the powder into a paste with a glutinous substance, and forming the carbons by pressing them through dies, the carbons being afterwards baked in retorts. In the carbons employed in flame arc lamps, the salts of sodium, calcium, and strontium are introduced with the glutinous material. In one form also, those used in the "Excello," made by the Union Electrical Co., a thin wire is also introduced into the carbon to lessen its resistance. In several of the flame arc lamps the ends of the two carbons project downwards into an inverted basin of lime or a similar substance, which performs the office of a reflector and condenser. When the lamp is not burning, the ends of the two carbons either rest against each other, or the two ends rest against a piece of iron which completes the circuit. When the current is switched on, either an electro-magnet, or some equivalent apparatus, either pulls one carbon away from the other, pulls the two carbons in opposite directions, or pulls the piece of iron away from the ends of the carbon. In either case the arc is then struck between the ends of the carbon rods in the usual way, but it is a horizontal and not a vertical arc, as in the ordinary form of lamp. In addition to this, in all forms of flame arc lamp there is an electro-magnet, whose office is to repel the arc formed between the carbons. One important property of the electro-magnet which has received very little attention, and very little use previously to the introduction of the flame arc, is its ability to repel the arc. In the flame arc lamp the repulsion by the electro-magnet spreads the flame out in the form of a fan, and this, aided by the reflector above, gives the lamp itself the appearance of a globe of orange-coloured flame. It will be noticed that there are, in the majority of flame arc lamps, no objects below the arc, as there are in the other forms of arc lamps, to cast shadows, and therefore a very much better lighting effect is produced.

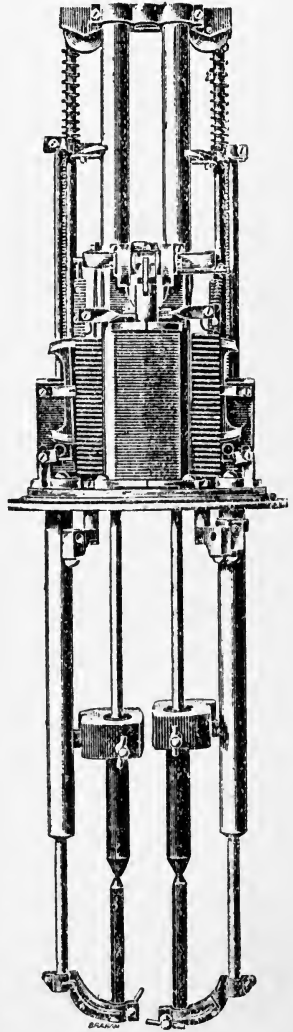

FIG. 30.—"Angold" Double-carbon Open-type Arc Lamp for Rectified Current.

It is also claimed that the flame arc gives a larger quantity of light for a given expenditure of electrical energy than either of the other forms of arc lamps. Fig. 31 shows the "Excello" flame arc lamp. Fig. 32 shows the larger light claimed for a flame arc.

The Juno Flame Arc Lamp.—As explained, in the great majority of flame arc lamps, the striking mechanism is an electro-magnet acting either directly or through the mechanism common to the particular type of lamp. Thus, in the Excello flame lamp, the Krieger and Mathiessen form of mechanism has been maintained

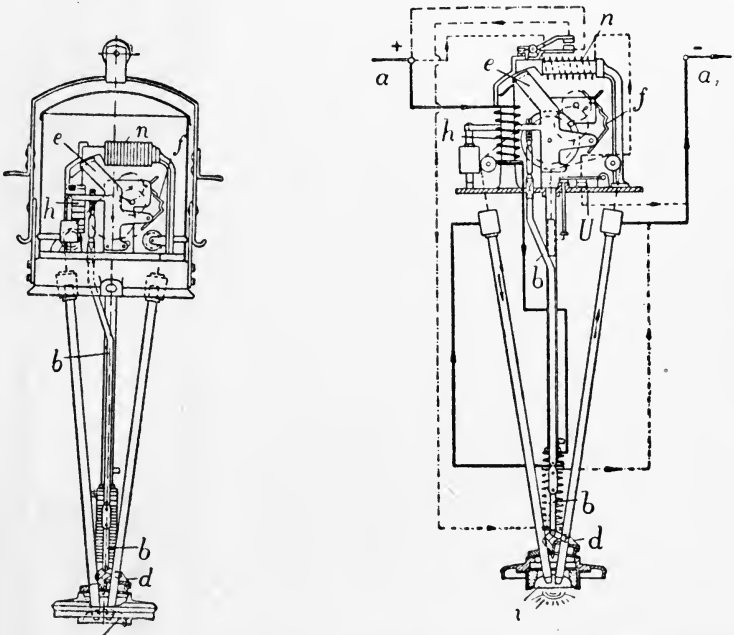

FIG. 31.—Sections of the "Excello" Flame Arc Lamp. *h* is the Main Electro magnet, *n* the Shunt-magnet, *b* and *d* are the Arc Mechanism.

for striking the arc; also, in the Luna flame arc lamp the mechanism employed in the ordinary Luna lamps has also been used. Messrs. Johnson & Phillips, however, have introduced a distinctly novel form of mechanism for striking the arc, and in doing so they have been enabled to simplify the apparatus. In the Juno flame lamp the striking mechanism is operated by the expansion of a nickel steel wire, when the current passing to the arc goes through it. The arrangement is a very simple one. One carbon lies against the other when the current is not switched on. When the current passes,

the nickel steel wire expands, and in expanding operates a trip lever which pulls the movable carbon away from its fellow, the length of the arc being regulated by screws provided for the purpose. The spreading electro-magnets are two iron rods, which are used to support the lower part of the lamp where the reflector is placed, with insulated wires wound round them, the current passing through these wires on its way to the arc. The feeding mechanism is also very simple, one carbon simply slides down against a projection arranged for it, and the other carbon slides through a tube as far as it is allowed by the arc-striking mechanism. The arrangement and con-

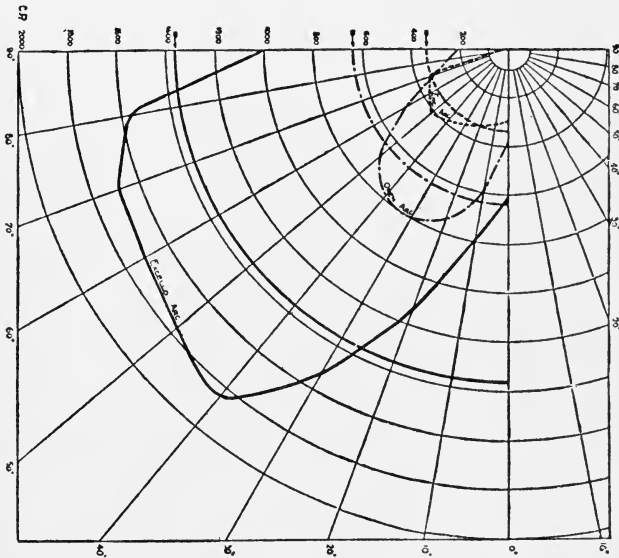

FIG. 32.—Showing the larger Quantity of Light given by Flame Arcs, as claimed for the "Excello" Lamp. The Dotted Line shows the Light given by an Ordinary Arc, the Thick Line that claimed for the "Excello" Lamp. The Candle-powers are shown by the Figures at the Ends of the Curves, and the Angles by the Radii.

nections are shown in Fig. 33. The author has introduced the description of the flame arc lamp, though he is not aware that it has yet been employed in mining work, because it appears to him that it would be of great service in coal screening at night. One of the difficulties of properly cleaning the coal by artificial light, as he understands, is that some kinds of shale and dirt have very much the same appearance as coal, when viewed by artificial light. All forms of artificial light, in the author's experience, are rich in the red rays

of the spectrum, and it is for this reason that the difficulty arises on the picking belts. The flame arc lamp, providing that proper salts

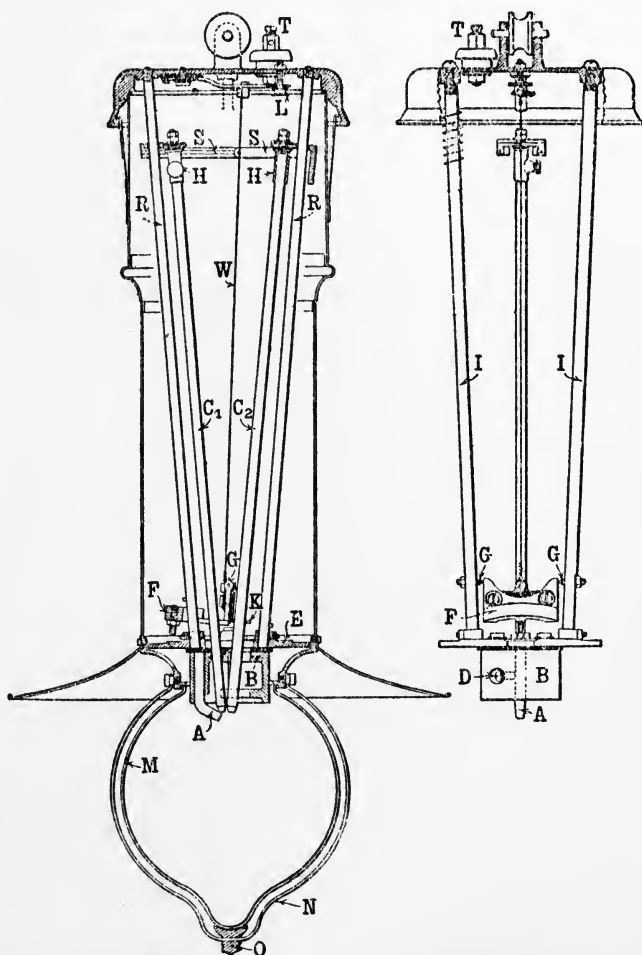

FIG. 33.—“Juno” Flame Arc Lamp. *A* is a Copper Rest for the Stationary Carbon, *B* is a Metal Cap shielding the Arc, *C₁* *C₂* are the Carbons, *D* is a Screw holding *A* to *B*, *E* is an Insulated Brass Plate, *F*, *G*, and *K* is the Apparatus for striking the Arc, *W* is the Nickel Steel Wire which heats, *RR* are the Electro-magnetic Rods which spread the Arc.

are used in impregnating the carbons, is, in his experience, the only exception. The light given by the flame arc, in which the salts of

sodium are predominant, gives light practically the same for colour purposes as sunlight. The author has tested every form of artificial light for colour.

Delivering Current to the Arc Lamps.—The simplest arrangement for delivering continuous current to arc lamps where the service is either 110, 220, or 500 volts is by connecting two or more lamps in series, the series being connected between the supply cables. Fig. 34 shows a diagram for lamps from 2 upwards. As explained, two open arc lamps work from 110 volt services, and may, by careful regulation, be made to work from a 100 volt service. Four open arc lamps work in series across a 220 volt service, eight across a 440 volt service, and from nine to ten across a 500-volt

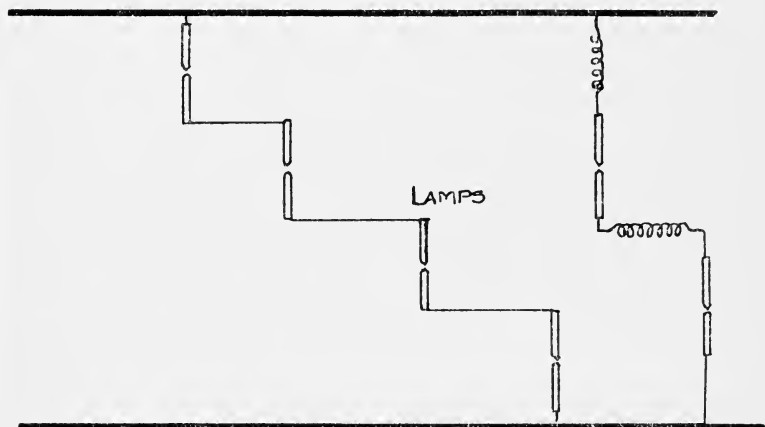

FIG. 34.—Diagram of Connections for Two and for Four Arc Lamps, between 200 to 220 Volt Service Mains.

service. A simpler arrangement, however, and one that will probably prove more economical where a varying number of lamps are required to be in use together, would be the employment of a motor generator, in the same manner as described in connection with electric signals, the generator of the motor generator being constructed to furnish 65 or 110 volts, as convenient. Where there are a number of arc lamps in use, if some of them are not required at certain times, as may very frequently happen, the current that would be employed in them must be wasted, or the carbons in the lamp must be burned uselessly. By the arrangement of the motor generator, one or two lamps can be arranged to be taken off the service at any point required, and each lamp may be switched in and out as and when convenient. Fig. 35 shows the arrangement

for this. The arrangement has also the great advantage that where the service is three-phase alternating, the arc lamp and incandescent lamp service also, if required, may be kept quite independent of the power service, while full advantage is taken of the three-phase distribution.

Delivering Alternating Current to Arc Lamps.—Arc lamps employing alternating currents may be connected across a 100, 110, 220, 440, 500, or practically any alternating current service in series, just as continuous-current lamps are, but with the advantage explained above, that the pressure taken by the lamps is smaller, three lamps being sometimes worked on 110 volt service,

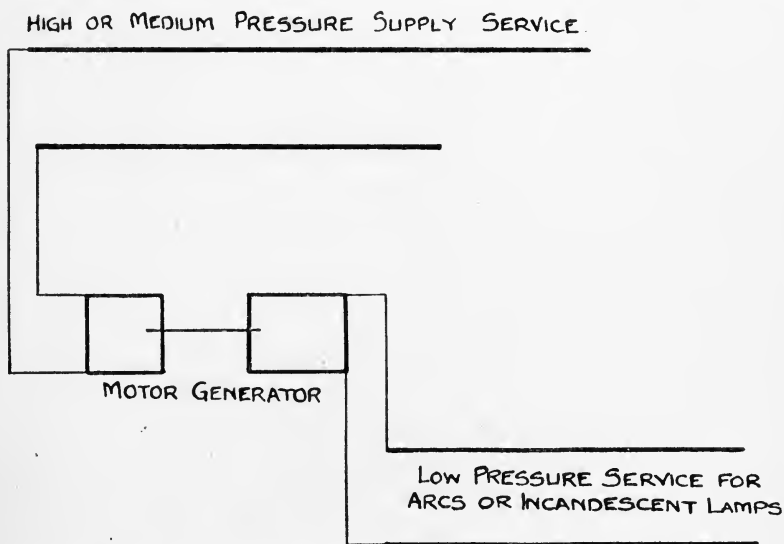

FIG. 35.—Diagram of Arrangement for running Arcs, or Incandescent Lamps, from a high-pressure Service, by the Aid of a Motor Generator.

and with the advantage also that the choking coil or compensator arrangement enables one or more lamps of a series to be in use without very much waste of current in the compensating apparatus. Arc lamps may also be worked individually from a single-phase, alternating current service by fixing a transformer to each lamp, the transformer being connected across the supply service. Alternating current lamps may also be worked on two-phase and three-phase systems, the lamps being either bridged in series between the pairs of cables in the two-phase system, and between any two cables in the three-phase system, or being supplied by transformers taking current

from two of the cables in either system. The alternating current lamp, it will be understood, only works with single-phase currents, and can therefore only be used on two and three phase services by connecting them either singly or in series in each of the phases. Where many arc lamps are employed, taking current from a two or three phase service, they should be distributed equally, as far as possible, between the phases, whether they are supplied directly from the two or three cables, or through transformers. It is important,

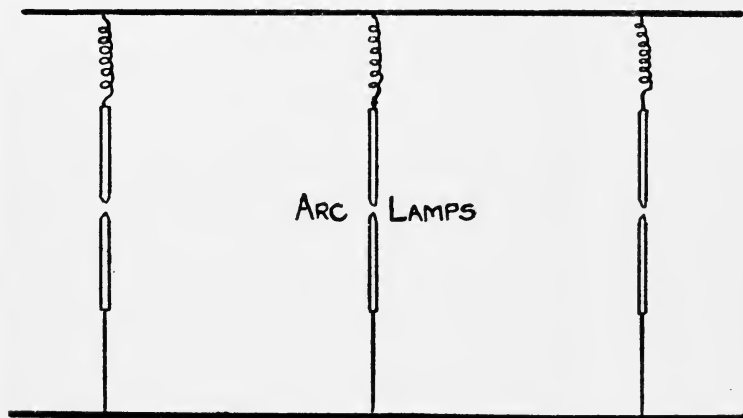

FIG. 36.—Diagram of Connections of Arcs in Parallel across a 65 or 100 Volt Service. Each Arc has its own Resistance as shown. This is the Arrangement that would be employed where Current was taken for the Lighting Service, from the Power Service, through a Motor Generator.

with two and three phase working, that the same current strength shall be passing in the two and three phases. Apparently a small difference in one phase does not make any difference in the working of a well-designed and well-made two or three phase generator, but it must lower the whole efficiency of the system. Where several arc lamps are to be run in series, rectified alternate currents are sometimes employed with success.

Difference in the Working of Continuous and Alternating Current Arc Lamps

The important difference between the working of arc lamps supplied with continuous current and with alternating currents, apart from the distribution of the light, is, it is necessary with continuous current lamps usually to insert a resistance in the circuit,

in order that the lamp may strike its arc. With continuous current lamps, also, it is usual to provide automatic cutouts to bridge the lamp over, in case the carbons stick. With alternating currents both of these offices are performed by what are variously termed choking coils, compensators, and by other names.

With the continuous current arc lamp, except in the case where the armature controlling the striking mechanism moves through a short distance, and is then locked by contact with the poles of the electro-magnet, if the full current is allowed to pass into the lamp when it is switched on, it will not strike its arc, but the upper carbon, or the two carbons where both move, will perform the operation known as pumping. The carbons will be separated by a distance too great for the arc to form. They will then return into contact, be again separated, return to contract, and so on. The reason is, the solenoids which are so generally employed with arc lamps have a very long stroke, and the pull of a solenoid coil upon its iron core increases very rapidly as the core passes into the coil. The pressure required in an arc lamp is made up, partly of the pressure required to drive the current through the solenoid coils, the carbons, and the resistance of the arc, but the greater portion is required to overcome the back pressure created in the arc itself, at the crater. When the current is first switched on, the back pressure is absent, and therefore a very powerful current passes through the solenoid coils, producing a very quick action upon the solenoid core, separating the carbons very quickly, but producing no arc. The remedy for this is, if the lamp is burning directly from a supply service, as was common in the early days of lighting, a resistance is inserted in the circuit sufficient to reduce the current, and an additional pressure is provided to overcome this resistance, the figures for a 10 ampère lamp being a resistance of 15 ohms,

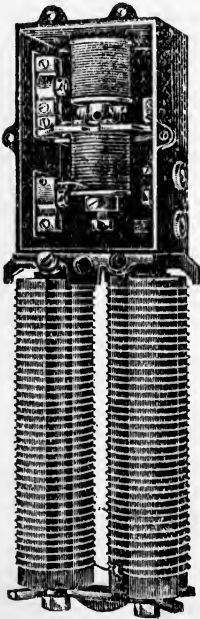

FIG. 37. — Automatic Cutout for Continuous Current Arc Lamp, with the Resistance that is to take the Place of the Arc, as made by the General Electric Co., London.

and the increase of the pressure from 50 to 65 volts. This would be the arrangement where current is taken from a motor-generator, and is shown in Fig. 36. With modern arrangements two open arc lamps are usually run in series on a 110 volt service, a resistance absorbing the 10 volts, or four open arc lamps are run on a 220 volt service or upwards, the arrangement of the resistance being suited to meet the

pressure of the service. With enclosed arc lamps one lamp can be run directly on a 110 volt service, or two on a 220 volt service, an adjustable resistance being included in the lamp-case to absorb the pressure over and above that required for the arc. As explained, the enclosed arc absorbs from 70 to 80 volts. The arrangement of two lamps in series with open arcs, together with a resistance, and one lamp with a resistance with enclosed arcs, meets the case of the necessary reduction of the current when the lamp is started.

Continuous Current Automatic Lamp Cutouts.—Where either open or enclosed arc lamps are run in series some provision is necessary in case one of the lamps refuses to burn, either by its carbons remaining in contact, and the back pressure of its arc being entirely absent, or, as is more common, the feed mechanism not acting properly, and the arc being extinguished through the carbons being allowed to burn too far apart. The usual arrangement with

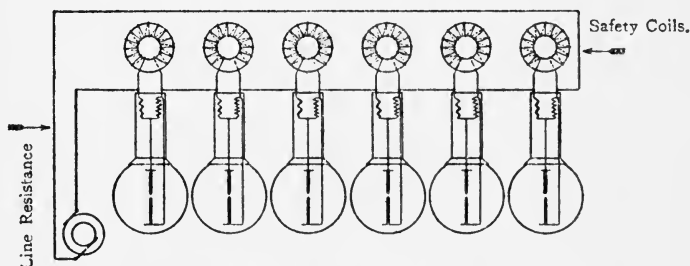

FIG. 38.—Diagram of Alternate Current Arc Lamps, connected in Series, with Choking or Balancing Coils, as arranged by the Electric Co.

continuous current arcs is, an auxiliary electro-magnet, of which one form is shown in Fig. 37, and is fixed either in the lamp-case itself, or in some convenient position in the neighbourhood, the coils of the magnet being wound with two wires, one a very fine wire, usually in series with the shunt coils of the lamp and receiving the same current as they do, the other a thick wire sufficiently large to carry the whole current. The armature of the electro-magnet carries a contact which, when the shunt coils of electro-magnet have acquired sufficient power to overcome the tension of the opposing spring, makes connection with a contact piece to which is connected a resistance sufficient to absorb the whole of the pressure taken by the lamp when burning.

Choking Coils and Compensators.—With arc lamps employing alternating currents, what are termed choking coils take the place of the adjustable resistances mentioned in connection with continuous

current arcs, and the automatic cutout is replaced by some form of what are known as compensators. The choking coil is merely a

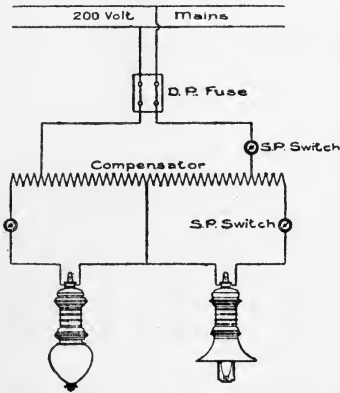

FIG. 39.—Diagram of Connections for Working One or Two Arc Lamps from a 200 Volt Alternate Current Service without Appreciable Waste, as arranged by the British Thomson-Houston Co.

short coil of wire of sufficient thickness to carry the current for the arc, coiled round a laminated iron core. Choking coils are made in various forms. They are really electro-magnets, and they are made sometimes with one leg, sometimes with two, and with the magnetic circuit of the coil completed. In either case the self-induction of the current in the coils surrounding the iron, due to the variations and reversals of the alternating current, create an opposing pressure, and "choke" back the current, using up the surplus pressure in the same manner as the resistance coils use up the surplus pressure with continuous currents. The choking coils are made adjustable either by connecting different lengths of coil in the circuit, or by adjusting the position of the iron coil. The choking coil is

inserted in the main circuit of the lamp it is to regulate, and it absorbs

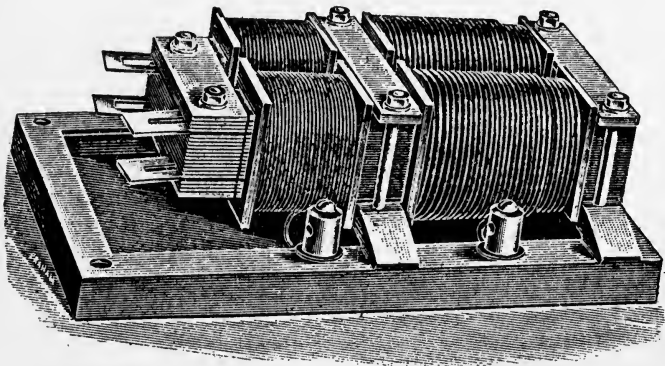

FIG. 40.—"Economy Coil," or "Compensator," made by the General Electric Co., for Use with Alternate Current Circuits. It is regulated by moving the Coils on the Left.

a very small quantity of energy. Some energy is absorbed, but it is only a fraction of that which would be absorbed by another lamp. The

arrangement is extended to enable two or more lamps to be worked from 100 or 200 volt service, but so that any individual lamp can be burned by itself with only a small expenditure of electrical energy outside of the lamp in the balancing coil or compensator, as they are called. Diagrams of the arrangement for working with compensators or balancing coils are shown in Figs. 38 and 39. Fig. 40 shows one form of a "choking coil."

Supporting Arc Lamps

The mechanism of all arc lamps is carried by a brass platform, usually circular, and is also usually covered by a brass disc above, and is protected by copper or iron or brass cylinders, made to slide one over the other, and to completely enclose the mechanism. The lamp is always suspended by a glazed earthenware or, preferably, a porcelain reel insulator, held in a small bracket, secured to the top of the lamp so that the arrangement is insulated from all the lamp connections, as shown in Figs. 23, 24, and others. The lamp may be supported from any convenient position by any convenient method, using the reel insulator for the purpose. A convenient method is, a flexible galvanized stranded rope is used for a support, one end being secured to the reel insulator, and the other end taken over a pulley in the position to which the lamp is to be hoisted, and from there, if necessary, over other pulleys to a small winch fixed in any convenient place. For pit-heaps, the first pulley round which the galvanized strand is taken may be secured to one of the longitudinal members of the pit-heap cover, the strand being then taken down over other pulleys secured, to other parts of the structure to a winch at the side. A similar arrangement is suitable for engine-houses where arc lamps are employed, and for pit bottoms if an arc is employed there. For sidings and open spaces about the mine, poles may be employed. If they are of wood they should be creosoted, as a creosoted pole lasts from five to six times as long as one not creosoted. Un-creosoted poles are attacked at the surface of the ground, and in the course of four or five years will become so rotten there that a storm will blow them down, with damage to the lamp and other trouble. A good strong creosoted pole with creosoted arms bolted to its top, to which pulleys are fixed, forms a very convenient arrangement, the winch for the galvanized rope being fixed near the bottom of the pole. The pole should be stayed, and the wires leading to the lamp should be fixed to insulators carried on arms, also bolted to the top of the pole above, and well clear of the hoisting mechanism. Iron lamp-posts are better than wooden posts, and are not very much more expensive. The base of the iron lamp-post is made hollow, usually square, and the winch for the hoisting

rope is fixed inside the base, but can be arranged to be worked from the outside by allowing the axle of the winch to project through a hole in the side. It is better, however, to enclose the whole thing. The base of the iron lamp-post also provides a convenient place to fix automatic cutouts, choking coils, compensators, etc. Where a lamp-post is used, the galvanized iron rope is carried up inside the post, the upper part of which is made of a straight tube, and the actual support of the lamp is also a tube bent to any convenient form. Lattice-work poles are also used, as shown in Fig. 41. They are light and strong.

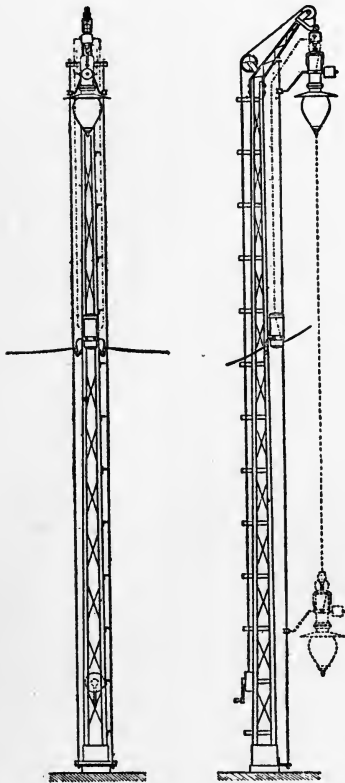

FIG. 41.—Lattice-work Iron Lamp-post for Arc Lamp, with Winch, Galvanized Rope, etc.

Contact Supports for Arc Lamps.—The problem involved in trimming and cleaning arc lamps is a more or less troublesome one, principally because of the leads. If the cables leading to the lamp are made sufficiently long, to allow the lamp to be lowered to within reach of the ground, they sag about when the lamp is in its position for lighting, particularly when there is much wind, and the insulation is liable to be damaged. These considerations have led to the development of a series of contact arrangements for arc lamps, which avoid the necessity of providing the dangerous lengths of loose leads. The bracket which supports the lamp carries a hood, in which contact springs or equivalent arrangements are fixed, the ends of the cables from the supply service being connected to these springs. On the top of the lamp-case are also springs or plates forming the terminals, and when hoisted into its place, the top of the lamp passes into the hood mentioned

above, the terminal plates or springs making connection with the terminal springs or plates in the hood. Several devices have also been introduced complementary to these, designed to relieve the hoisting mechanism of the weight of the lamp after it is hoisted into position. In the apparatus made by the General Electric

Co., the weight of the lamp assists in making good connection between the lamp terminals and those under the hood. After the lamp is hoisted into its place, the springs on the lamp-case spread out and engage with the contact pieces on the hood. In the

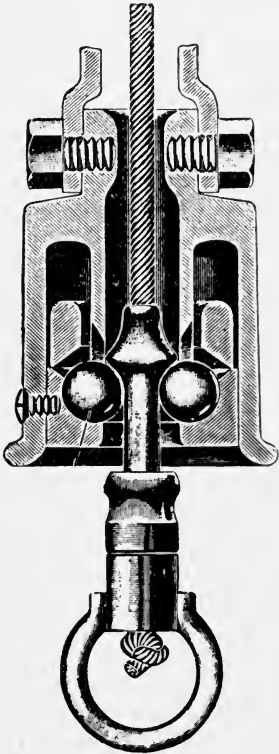

FIG. 42.—Section of Shaeffer Safety Hook for Arc Lamps. The Ring shown at the Bottom is fixed round the Insulator on Top of the Lamp. This Apparatus is only designed to support the Lamp so that it can be easily lowered. It has no Contact Arrangements.

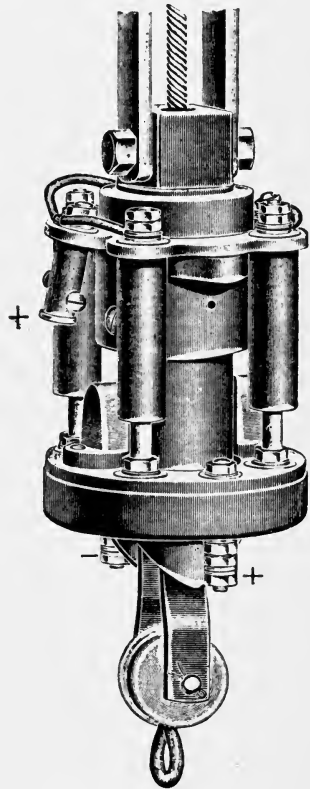

FIG. 43.—Another Form of Shaeffer Contact Support for Arc Lamps. In this Apparatus the Lamp is supported and Contacts made as well.

Shaeffer apparatus, shown in Figs. 42 and 43, there is a steel tube and three steel balls, the tube pushing the balls out of the way as it rises when the lamp is being hoisted into position, and afterwards resting on them. In the L.E.F. apparatus, a pin on the

apparatus attached to the lamp slips into a socket, in which it is locked, the weight of the lamp then being taken. In either case, a half turn or so of the winch raises the lamp a little off its support, and enables it to be lowered.

Incandescent Lamps

There are three types of incandescent lamp that are now available for use in mines, and that should do good work there. The ordinary carbon filament lamp, giving a light up to 50 C.P., the high C.P. carbon filament lamp, giving a light from 100 up to 500 C.P., and the metallic filament lamp. The small carbon filament lamp is too well known to require description. Its filament is made from cellulose, squirted through a dye, and formed in that manner into a long thread, which is cut into lengths, baked in retorts, fixed in the familiar pear-shaped globes, from which the air is exhausted, and built up into the steel-looking filament we know, by the precipitation of carbon from coal gas, the lamp globe being filled with the gas during what is called the flashing process. The ends of the filament are connected to small platinum wires, by different methods of jointing; a favourite one being, a small sleeve is made in the end of the platinum wire, the end of the carbon filament is inserted in the sleeve, a special paste is put in with it, and the whole is welded together by heat. Platinum is employed because it has the same coefficient of expansion as glass, and the platinum wires are sealed into the base of the pear-shaped globe before the filament is connected to them. The base of the pear-shaped globe is now almost universally enclosed in a brass cap, consisting of a cylinder of thin brass surrounding the neck of the lamp, the space being filled with a cement that does not absorb moisture, and in which one or two plates are embedded for the lamp connections. In the B.C. lamp (bottom cap) there are two semicircular brass plates on the bottom of the cap, bedded in the cement, and having the ends of the platinum wires connected to them. In the C.C. (central contact) lamp there is one circular brass plate, fixed centrally in the cement enclosed by the cylinder of the cap, having one of the platinum wires connected to it, the other being connected to the cylinder of the cap itself. The outside of the cylinder of the cap is fitted with two pins which engage in the bayonet joint holder, so universally employed. The small carbon filament lamp is sometimes fitted with a cap of a substance called "vitrite," a substance that is an insulator, and which is claimed not to readily absorb moisture, and which can also be moulded into any form required. The "vitrite" cap is of the same shape as the brass cylindrical cap, the "vitrite" filling up the whole space, the brass contact plates lying on its surface at the bottom of the cap, the platinum

wires passing through, and being embedded in it, and the brass pins for holding the lamp in the lamp-holder being also embedded in it. For central contact lamps, the "vitrite" has a brass cylinder outside, to which one end of the filament is connected through its platinum wire.

The light given by the carbon filament depends upon its length and its surface, and the temperature to which it is raised. What are known as high efficiency lamps are raised to a higher temperature than the low efficiency lamps, a more powerful current being allowed to pass through them.

The small carbon filament lamps are made for 5, 8, 12, 16, 25, 32, and 50 C.P. The 16, 25, 32, and 50 C.P. lamps are all made for pressures from 60 to 120, and from 150 to 250 volts. As the light given by a carbon filament depends upon its length, and surface, and temperature, it will be understood that a filament that gives 8 C.P. with 50 volts, if its length is doubled will give, approximately, 16 C.P. with 100 volts; and if its length can again be doubled, it will give 32 C.P., approximately, with 200 volts. The length, however, of the filament of a lamp giving 16 C.P., say, with 200 volts, is more than twice the length of the filament of a lamp giving the same candle-power with 100 volts, the reason being the smaller surface of the smaller filament, per inch. In order that the filament may give a certain light with double the pressure, a longer and thinner filament is employed, having a higher resistance, taking a smaller current, but the length is more than doubled for double the pressure. Hence, for this and for other reasons, the high voltage small carbon lamps, as they are called, those burning at from 200 volts, and upwards, are not so efficient; they require a larger expenditure of electrical energy per C.P. than the lower voltage lamps. A common standard 16 C.P. lamp, with 100 volts, takes 60 watts. The 16 C.P. lamp, to burn with 200 volts, takes 70 watts. The life of the higher voltage lamps is also less than that of the lower voltage. About a mine there is no advantage whatever in using high voltage lamps, except where current is taken directly from the power service, as where two 220 volt lamps are connected across a 440 volt service, or two 250 volt lamps across a 500 volt service. Wherever it can be arranged, it will be found more economical in every way to run the lighting service at the lower voltage. The small carbon incandescent lamps are made to burn at $2\frac{1}{2}$ watts per candle, 3 watts per candle, $3\frac{1}{2}$ watts per candle, $3\frac{3}{4}$ and 4 watts. With a 100 volt service a 16 candle lamp, at $2\frac{1}{2}$ watts per candle, takes 0.4 of an ampère; with an efficiency of 3 watts it takes 0.48 amp.; with $4\frac{1}{2}$ watts it takes 0.56, and with $3\frac{3}{4}$, the usual standard lamp, 0.6. Higher voltage lamps and higher candle lamps take current in the same proportion. Thus, the 200 volt lamp, burning at $2\frac{1}{2}$ watts efficiency, takes 0.2 amp.; at 3 watts

it takes 0.24 amp., and so on. The 100 volt 32 C.P. 3 watts efficiency lamp takes 0.96 amp., and the 200 volt lamp burning at a similar efficiency, 0.48, and so on.

The Gem Carbon Filament Incandescent Lamp

There is another newly developed incandescent lamp, which it is hoped will compete with the metallic filament lamps. It has been worked out by the General Electric Co. of America, and, the author understands, is constructed from the ordinary carbon filament by subjecting the filament to a very high temperature in an electrical furnace of the resistance type, the furnace in which heat is imparted by raising the temperature of some low conducting body, either surrounding or in the furnace, but without any arc being formed. It is called a metallized filament, and it has the property, also possessed by metallic filament lamps, that its resistance increases with increasing temperature, instead of falling as in the ordinary carbon filament lamp. This change is a most important one, and tends to lessen the winking of incandescent lamps with changes of pressure. With the ordinary carbon filament lamp, when the pressure increases, the current passing through the lamp increases, and this lowering of the resistance causes a further increase of current, with a further increase of temperature, and so on, till the limit is reached, the result being that comparatively small increases and decreases in pressure are visible. This has led also to the necessity of alternating currents being worked at the comparatively high frequency of 25 periods per second. Below 25 periods, and even with 25, with some very thin filament lamps, there is a distinct difference in the light given by the lamp at different parts of the cycle. A wink is distinctly noticeable. On the other hand, for efficient power distribution, the frequency should be as low as possible. The efficiency of the Gem filament lamp is given as $2\frac{1}{2}$ watts per candle, the life being then the same as that of the 3 watts per candle ordinary carbon filament lamp. The efficiency and the life will probably be improved as time goes on.

Metallic Filament Lamps

There are two metallic filament lamps on the market, and others are coming apparently very fast. Those on the market are made of very fine wires of the rare metals, tantalum and osmium. The filaments, as they are termed, are very much longer in the tantalum lamp than in the carbon filament lamp, and they are formed into a kind of cat's cradle inside the lamp globe, which is of the same form as that of the small carbon filament lamp, the wire being wound up and

down round glass hooks on a glass bridge fixed in the middle of the lamp. Platinum wires, as before, are employed for connecting the ends of the metallic filament lamps with the plates on the lamp cap, which is of the same form as used with the carbon filament lamp. The lamps are only made at present for pressures of 50 to 125 volts, and C.P.'s of $6\frac{1}{2}$ to 26, so that the lamp must be connected in series on a 220 volt service, unless some arrangement is made for supplying current at a pressure suitable for these lamps, as by a motor generator. The tantalum lamp is made for efficiencies of from 1·7 and 2·2 watts per candle; this meaning that approximately half the current is required with any given lamps. The life of the tantalum lamp is claimed to be 1000 hours, and 600 hours before the light is reduced by 20 per cent. As usual with a new apparatus, the metallic filament lamps are more expensive to purchase than the carbon filament, but as they consume so much less current, the difference is soon paid. The success of the tantalum and osmium lamps has led to other metals—wolfram, tungsten, and others—being employed for the same purpose.

The osmium lamp has developed into one called the "Osram," which is made for C.P.'s of 0·4 up to 16, and in the case of lamps of 8 C.P. upwards, is made for pressures from 8 volts upwards. The efficiency claimed is 1 watt per candle.

High C.P. Incandescent Lamps

The high C.P. incandescent lamp is similar in construction to the small carbon incandescent lamp, except that its filament, to use the term usually employed, is a stick of carbon, generally bent into a U form. Its ends are connected to platinum wires, as the small carbon filament lamps are, but there are several platinum wires to each carbon end, the number depending upon the size of the filament, and the current it is to accommodate. The filament is enclosed in a globe of varying size, according to the light given.

There are two distinct forms of high C.P. incandescent lamps. Those made by The Sunbeam Co., of which the efficiency is 2 and $2\frac{1}{2}$ watts per candle, and those made by other firms, of which the efficiency is more nearly 4 watts per candle. The 2 watt efficiency lamp is, in the author's experience, a very economical lamp, and in many cases would be preferable to arc lamps.

The Efficiency and Life of Incandescent Lamps.—The question of the efficiency at which carbon incandescent lamps should be run is one that depends upon the cost of the current. Where current is dear, as in some town supply services, it is cheaper to burn lamps at high efficiency, and to replace them when they begin to give less

light. Where the current is cheaper, as will be the case in the great majority of mines generating their own current, it is more economical in every way to burn lower efficiency lamps, and in the author's experience it has been found better to burn even low efficiency lamps at something below their marked pressure. From the moment that the lamp is put into service, a disintegrating action commences. The carbon filament is gradually broken up, and a bombardment of very minute carbon particles takes place, from the filament on to the glass, the result being that the filament takes less current, emits less light, and the glass gradually becomes blackened, and transmits less light. This action increases very rapidly with the temperature, and so high efficiency lamps begin to blacken very much more quickly than low efficiency. In addition, as explained, if the low efficiency lamp is burned with a pressure five per cent. or so below its marked pressure, though it gives less light, about twelve to fourteen candles with a 16 C.P. lamp, there is usually plenty of light for a great many situations, and the life of the lamp is very much increased. Only a very small percentage of the energy delivered to the carbon filament, some three to five per cent., appears as light, even in the very high efficiency lamps, the remainder, so far as is known at present, being radiated as heat.

HOLDERS and Fittings for Incandescent Lamps.—For small carbon filament lamps, the familiar bayonet-joint holder is the almost universally employed holder. It consists of a short tube of stout brass, of sufficient length to allow the lamp-holder to enter nearly up to the neck of the lamp. The tube is slotted at opposite ends of a diameter, with the straight and curved slots known under the name of the bayonet joint. The brass pins, which are fixed on opposite ends of a diameter of the cap of the lamp, are pushed into the straight part of the slot in the holder, and when they arrive at the curved portion, the lamp is given a small twist to the right, the pins then passing projections in the slots, and on the lamp being released from the hand, the springs of the plungers described below, force the pins behind the projections in the bayonet slot, and lock the lamp in position. At the back of the tube forming the lamp-holder, is a disc of highly glazed and special porcelain, or other material specially arranged to withstand comparatively high temperatures. In this disc are fixed two little plunger contact pieces. The contact pieces are arranged to receive the connecting wires from the supply service through holes in the porcelain disc, the wires being held in position by screws provided for the purpose. On each contact piece is a small hollow cylinder, with a small solid plunger in it, a small steel spring being placed in the tube behind the plunger, the result being that the plungers are forced outwards, and therefore make good connection with the plates on the bottom of the cap of the lamp,

when the latter is forced into position. The slotted tube and the porcelain disc, and its plungers are held in a hollow brass fitting, the two portions being connected together by brass rings, so that the whole can be taken apart, when the lamp-holder is connected to the service. The different parts of the lamp-holder are shown in Fig. 44. The fitting which holds the tube and the disc, has sometimes merely a female thread at the end, sometimes it has another screw with what is termed a cord grip, two pieces of wood or other insulating material forming together a cylinder, with grooves for the flexible cord by which the lamp is suspended, to lie in, and arranged to be tightened up by means of a small ring, so as to take the weight of the lamp off the connecting screws in the

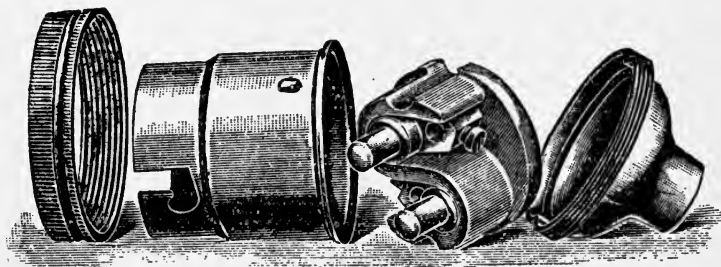

FIG. 44.—Showing the Different Parts of an Incandescent Lamp-holder. To the Left is the Ring with Female Thread which holds all together. Next to it is the Tube with Bayonet Joint into which the Cap of the Lamp enters. Next to it is the Porcelain Disc with the Plunger Contacts, and on the Right the Piece forming the Back of the Holder through which the Wires enter.

plunger contacts. Fig. 45 shows different forms of lamp-holders. The lamp-holder and its lamp may be held by merely screwing the lamp-holder on the end of a piece of brass or iron tube, forming a bracket, the other end of the brass or iron tube either having a brass back for fixing against a wall, or being screwed into a boss forming part of a fitting, to which two or more other tubes are attached. The brass or iron bracket may also carry a gallery, on which a shade is held, very much as in the case of a gas fitting. The above arrangement is that common for houses, offices, etc., and is suitable for the offices about a colliery, for engine-houses on the surface, for weigh-cabins, and many other places where there is no danger of gas, or of the lamp being broken by objects being thrown, or flying against it. For a large portion of mining work, however, for the pit top, the screens, the pit bottoms, engine-houses underground, roads underground, pump-houses, etc., some protection is necessary

for the lamp and for the connections, both from gas and from moisture. There are many different arrangements, but they are all on the same lines. Usually for mining work the wires which bring the current to

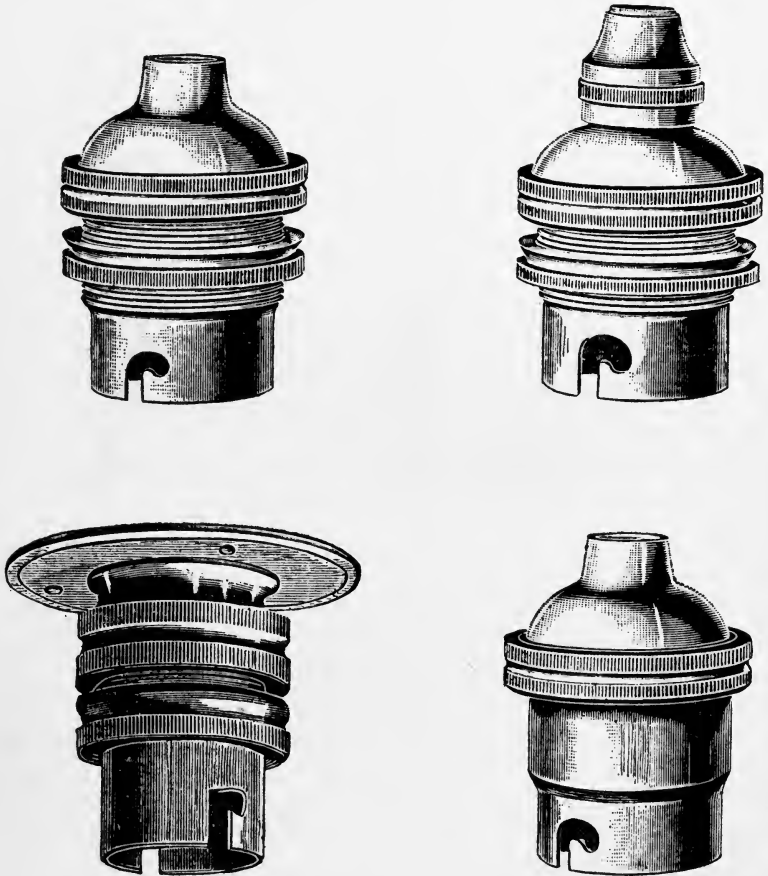

FIG. 45.—Forms of Lamp-holders. The Upper One on the Left is for screwing to a Bracket, and has a Ring to hold a Conical Shade. That on its Right is for Pendant Lamps. It has the Cord Grip described, and a Ring for holding a Shade. That on the Left below is for screwing against a Beam or Wall. It has a Ring for holding a Shade. The Holder on its Right is for screwing to a Bracket without a Shade-carrying Ring.

the lamp or lamps, are enclosed inside a substantial iron tube; the lamp end of the tube has a reflector screwed to it, and to the reflector some arrangement is added that will hold a glass shade. In addition

a wire guard is also sometimes fixed outside of the glass shade. The end of the iron tube, away from the lamp, has a flanged back, or some arrangement enabling it to be fixed against a wall, a beam, prop, or wherever it may be required. In fitting up, the connecting wires are brought to the lamp-holder, the lamp-holder is screwed into the end of the iron tube, the reflector being in its place, the bracket, or whatever form the fitting may have taken, is fixed to the wall, or wherever it is to stand, a substantial hard wood block being employed for the purpose, grooved to take the wires leading from the supply service to the lamp. The lamp is then pushed into its place in the lamp-holder, the glass shade with its wire guard is put into position, the latter being held sometimes by a bayonet-joint arrangement, and sometimes by screws. In some forms of fittings the reflector and the tube are cast in one, this making a more watertight and gastight joint, but with careful fitting this should not be necessary, and by having the reflector separate, enamelled iron, which answers remarkably well, can be employed, and the size of the reflector can be made such as will be convenient. For a great many situations the ordinary enamelled steel reflector, blue on the outside, and white on the inside, held by means of a screw ring on the lamp-holder will answer very well. Places where there is no damp, and where there is no danger of gas, can be supplied in this way. The enclosed fitting with the glass shade and its wire guard make a much better protection for the lamp where there is danger from mechanical injury, but it has the very serious disadvantage that coal-dust invariably works its way inside the protecting glass, depositing sometimes on the lamp globe and sometimes on the inner surface of the shade, but in all cases obscuring the light, and very often to a serious extent, with the result that the fittings have to be frequently taken to pieces for the purpose of cleaning the lamps, and fittings of this kind do not last as well when they are frequently taken to pieces. For some positions, as in confined pit bottoms, some pit heaps, some junctions of roads, a very useful fitting is one that is variously known as an oyster fitting, and a bulk-head fitting, the latter name being taken from the fact that it was designed principally for use on board ship. This fitting consists sometimes of a perfectly flat disc, either enamelled or painted white, arranged with a lamp-holder inside, the connections being brought to the holder, either through a hole at the back, or at the side, and the lamp being arranged to stand as near the centre of the disc as possible. Sometimes the disc is recessed or "dished," as it is called, the object being to give more room for the lamp, and to better utilize the back rays from the lamp filament. In either case the fitting lies close to the wall, and may be partially embedded in it. It may be fixed in a recess in a wooden headstock, where these are in use. Outside the lamp, and held by a ring at the circumference

of the disc, is a semi-cylindrical glass globe, or one forming a smaller portion of a sphere, the glass being protected in some cases by guard wires crossing it, and held by the ring which holds the glass in position.

Fittings for High C.P. Incandescent Lamps.—The high C.P. incandescent lamp is treated very much in the same manner as the small incandescent lamp with reference to brackets, shades, guards, etc., except that the tubes carrying the wires, the reflectors, the shades, and the guards must be larger in proportion. The lamp-holders, however, have to be of a different design. The lamp is made with a recess below the neck, and the holder most commonly employed consists of two porcelain discs held together by bolts and by the lamp terminals, and carrying three substantial brass springs which clasp the neck of the lamp, and are held to it by the spiral spring shown. The platinum wires forming the terminals of the filament are brought to clips held under the lower of the two discs, to which they are connected, and the lamp and holder are suspended by any convenient attachment, held by the porcelain discs.

The Nernst Lamp

The Nernst lamp, as explained, occupies a position midway between the arc and the incandescent lamp. It burns in the atmosphere, very much as the arc does, merely protected from the weather by an outer globe, for the same reason as the arc. The light, however, is given out by a glowing pellet of the substances

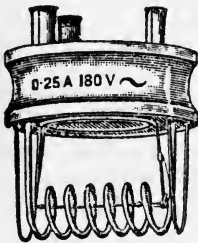

FIG. 46.—"Glower" and Heating-coil of Nernst Lamp, with the Porcelain Supporting Disc. The "Glower" is the Straight Portion inside the Coil.

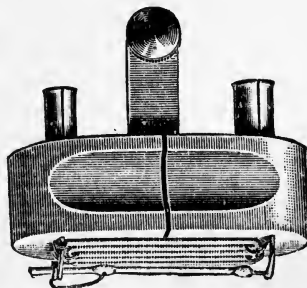

FIG. 47.—Another Form of Heating-coil for Nernst Lamp. It is seen above the "Glower."

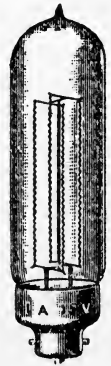

FIG. 48.—One Form of Resistance used with Nernst Lamp. The Thin Iron Wire is enclosed in a Small Tube similar to a Small Lamp.

employed in the Welsbach incandescent gas mantle, made from the very refractory rare earths—zirconium, yttrium, erbium, and others. The

pellet is called a "glower." It will not glow, however, and it will not allow a current to pass that will cause it to glow, unless it is first raised to a certain temperature. When cold, the glower has such a high resistance that practically no appreciable current passes through it. When raised to a certain critical temperature, current

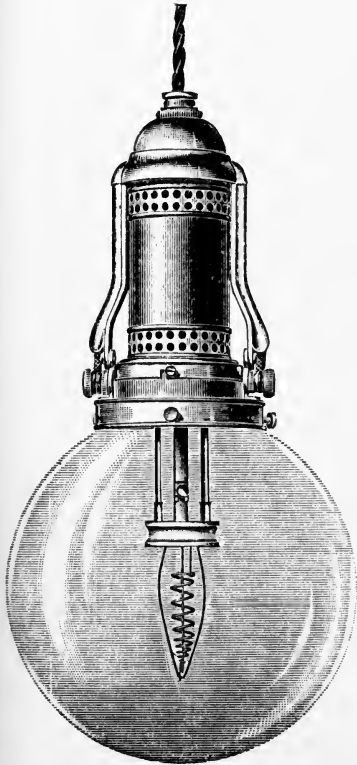

Fig. 49.—"A" Type Nernst Lamp with "Glower" vertical. The Heating-coil is seen surrounding the "Glower." The Lamp-holder is above the Lamp. The Terminals are seen on the Outside.



Fig. 50.—"B" Form of Nernst Lamp with Horizontal "Glower" and Heating-coil and Globe. The Holder, with the Electro-magnetic Cutout and Resistance, are inside the Metal Case forming the Upper Part of the Apparatus.

commences to pass through it in an appreciable quantity, raising its temperature, and causing it to give out an intensely bright white light. The heat required is delivered to the glower by a small coil of platinum wire, through which the current is passed when the lamp is

first switched on, as shown in Figs. 46 and 47, as well as passing through the glower itself. The glower takes from $\frac{1}{2}$ to $1\frac{1}{2}$ minute to acquire the necessary temperature, and when the lamp is burning normally, the platinum heating coil is switched out by a small electro-magnetic switch, which then comes into operation. In addition to the above, it is necessary to have a resistance in circuit

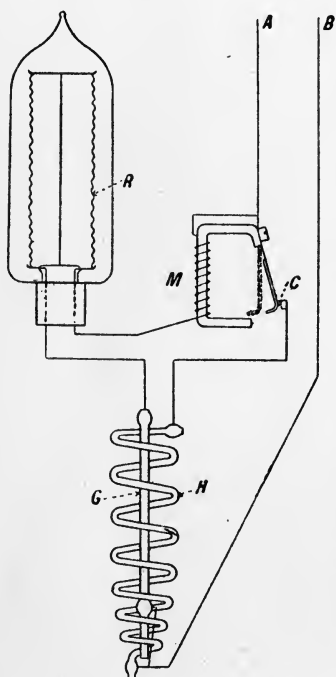

FIG. 51.—Connections of Nernst Lamp. *A* and *B* are the Service-wires, *C* is the Contact, which is broken when the "Glower" is heated, *G* is the "Glower," *H* the Heating-coil, *M* the Electro-magnet which cuts the Heating-coil out of Circuit, *R* the Balancing Resistance.

with the glower, very much in the same way as a resistance is fixed in circuit with an arc lamp, though for not quite the same reason. If the pressure at the terminals of the glower could be depended upon not to vary under any circumstances, the resistance would not be required; but as this is often difficult to arrange, and is never attained in the ordinary town supply service, for which the Nernst lamp has been principally worked out, a small piece of thin iron wire, contained in a small glass tube from which the air has largely been exhausted, is inserted in the circuit. It has a very critical temperature, just as the glower pellet has. If the iron wire, when at this temperature, is subject to further heating, its resistance rises very considerably for a comparatively small increase of heat, and therefore for a comparatively small increase of current. On the other hand, if it is deprived of a small quantity of heat, and therefore of current at this temperature, its resistance falls considerably. The result of this is, if the pressure of supply increases, the increased resistance of the iron wire, the compensating resistance, as it is called, uses up the increased pressure, the pressure at the terminals of the glower remaining practically constant, and if the

pressure falls, the lower resistance of the iron wire compensator frees a certain pressure, which again maintains the pressure at the terminals of the glower practically constant. The resistance is shown in Fig. 48. The whole of the above apparatus is contained in the lamp-holders shown in Figs. 49 and 50, to which the wires

connected to the supply service are brought, and which also is arranged to carry a globe or shade, as may be required. The connections of the lamp are shown in Fig. 51. The Nernst lamp is claimed to work with an efficiency of 1.5 watts per candle, and it should be of service for engine-houses, pit banks, pit bottoms with high roofs, and many other places where a good light is required. Fig. 52 shows the distribution of the light with different globes. The lamp is made for both continuous and alternating currents; but those made for alternating currents must not be used for continuous, and *vice versa*.

Further, the lamp must always be connected exactly as shown, the plus wire of a continuous current service being connected to the

terminal of the lamp marked plus. The reason of this is, there is apparently a transference of material from the positive to the negative terminal of the glower.

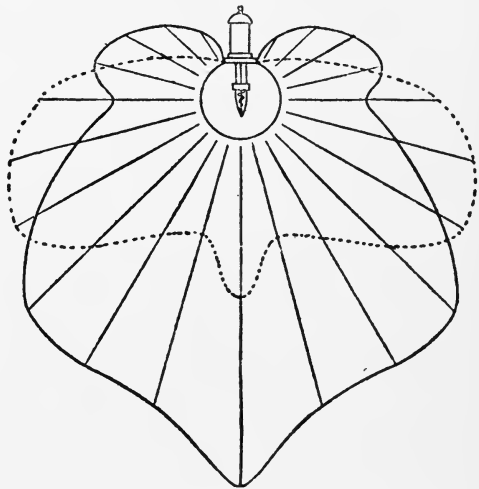

FIG. 52.—Curves showing the Distribution of Light with Nernst Lamp when enclosed in Pointed and Round Holophone Globes. The Full Curve is with the Pointed Globe, and the Dotted Curve with the Round. It will be noticed that the Light is more distributed with the Pointed than the other. The Lengths of the Lines meeting the Curves give the Proportional Intensity of Light at the Different Points.

Delivering the Current to Incandescent and Nernst Lamps

Incandescent lamps and Nernst lamps may be fixed anywhere, and may take their current from any cables where the pressure for which they are made is available, with the reservation mentioned in the case of the Nernst lamp, that only lamps made for alternating currents are to be used on alternating current services. As explained in Chapter I., the ordinary carbon filament lamp, and the metallic filament lamp, are marked for pressures which are applicable to either continuous or alternating currents, and they will burn upon any circuit, continuous, single, two or three phase, upon which this

pressure exists. Only single-phase currents must, of course, be used for incandescent lamps, but the lamps may be connected in each phase of a two-phase service, and between each pair of the three wires of a three-phase service. They may also be connected between each of the three wires of a three-phase service, and the wire connected to the neutral point of the service with star connection, as will be explained, always providing that the pressures are those for which the lamps are made. Incandescent lamps may be run two or more in series where convenient, as two 220 volt or two 250 volt lamps in series between the cables of a 440 or 500 volt service, no matter whether the pressure is that of a continuous current power service, or a two or three phase service. It is, however, unwise to run incandescent lamps in series as a general thing. Near the face where only a 440 or 500 volt service exists, the inconvenience to be mentioned, is more than outweighed by the convenience of obtaining a supply of current for light at the face. The inconvenience is, it is found, that when incandescent lamps are run in series, leakage occurs at each connection between the lamps, with the result that the positive lamp of the series receives more current than it should do, while each successive lamp receives less and less current, and gives less and less light, the positive lamp giving a much brighter light than the others, and burning out much more quickly. There is against this the solid advantage, at a pit bottom, for instance, of making only one break in the insulation of the cable for several lamps. The author's view is, that incandescent lamps at the pit bottom, in large engine-houses underground, and almost everywhere where a certain number of lamps are required, will be economically and conveniently run from motor generators, generating current at 100 or 110 volts. As explained, the lamps are stronger and more efficient, and the lighting service is kept quite independent of the power service, no matter what the pressure of the latter may be, while motor generators are made of any size, and can be fixed practically anywhere about the pit. There is no more difficulty in arranging a 100 volt lighting service off a 3000 volt three-phase service with a motor generator, than from a 500 volt continuous current service.

Portable Electric Lamps

From the moment the incandescent lamp became practicable, it was the dream of mining engineers and electrical engineers to adapt it for portable lamps, to take the place of the ordinary Davy or Clanny lamps. In the very early days an attempt was made to use lamps at the face of the coal, the lamps being rendered portable by connecting them to flexible wires leading to supply cables, but it was

soon seen that this was impracticable. There was too much danger of wires being broken and causing sparks that might fire gas. With the development of the flexible cables for coal-cutting machines, portable lamps on these lines might be arranged but for the difficulty that the motors of coal-cutting machines are run at pressures of 500 volts or thereabouts, and this necessitates at least two incandescent lamps in series, with the additional danger of breakage of the cable and additional complication.

Very early, also, after the invention of the incandescent lamps, attempts were made by Sir Joseph Swan and others, to construct small self-contained lamps with small batteries of accumulators carrying a small incandescent lamp, either on the side or at the top. The great objection was, if they were made sufficiently strong, and with a sufficient capacity for a working shift and something over, they were too heavy. The latest form of Davy lamp weighs a little over 2 lbs., and lamps giving a very good light indeed weigh only $3\frac{1}{2}$ lbs., while the electric lamps with their accumulators weighed 7 or 8 lbs. One lamp, however, has survived, known as the Sussman. In this lamp there are two small accumulator cells of the lead-oxide type, held inside a thin iron case, and with a small 4-volt lamp carried on the top inside a glass cylinder, and held by two porcelain reflectors, very much on the lines of the ordinary miner's lamp. The difficulty of the slopping of the acid has been overcome by filling the space between the plates with a substance, such as finely divided cork, that will absorb the dilute acid, just as a sponge does, without adding very much to the resistance. The lamp gives about 1 C.P. when the battery is first charged, and it will go on giving a light, gradually decreasing, for about 15 hours, so that if a man should be left in the pit, he has several hours' light in his lamp. A small switch is attached to the lamp, which, in the author's opinion, is its weak point, inasmuch as there is not space to make it sufficiently strong for mining work. On the other hand, there is no doubt that the use of the switch enables the capacity of the accumulator to be very economically employed. Lamps are charged, and are got ready for the miners, but need not be switched on until the individual miner presents himself at the lamp cabin; and therefore the storage battery is only losing by leakage, and not by actual current.

The lamps are arranged to be easily taken to pieces, the accumulators being charged apart from the lamps, and the usual method is, a number of them are arranged in a series, and connected across the lighting service with a lamp in series with them, to show that the current is passing. In the author's opinion this method is not really economical. A much better plan would be to fix a motor generator in the lamp cabin, the motor taking its current from the supply

service, whatever it may be, and the generator furnishing current at about 6 volts to a pair of bus bars, between which connections would be made for individual pairs of cells, so that the lampman would merely have to take the lamp apart, put the cells into position, and leave them to charge. There should be some arrangement for indicating that each battery was being properly charged, and this could either be one of the lamp globes employed with the lamp itself, or preferably a small low-reading ampère meter, showing exactly the current that was going into the battery. The portable electric lamp suffers still, however, from one want. The ordinary miner's lamp performs two offices. It gives light, and it indicates the presence of gas, the latter being accomplished by the elongation of the flame when gas is present, experienced miners being able to tell by the condition of the flame, approximately the percentage of gas present. Several attempts have been made to add gas-detecting apparatus to the portable electric lamp. The Sussmann Co. introduced an apparatus of the kind, which lighted a small red lamp attached to the lamp-case, in the presence of gas. And this was shown, and worked apparently quite satisfactorily with ordinary town's gas. Ordinary town's gas, however, consists very largely of hydrogen, and it was shown that it was the hydrogen gas which was operating the gas indicator. Mr. H. J. Prested worked out an apparatus which was free from this objection, in which the properties of a porous diaphragm were made use of, the gas in an explosive atmosphere passing through a porous diaphragm into a closed chamber, and, operating a contact, closing an electric circuit in which was an incandescent lamp coloured red, connected to the accumulator. The author believes that though this was very successful, not much has yet been done with it.

CHAPTER IV

THE GENERATION OF ELECTRICITY

The Electricity Generating Station

It is now acknowledged that the most economical method of distributing power about a mine, or to any group of mines, or in fact to any works occupying a large area is, by generating electricity at some convenient point, as central as possible, where a plentiful supply of water is available, and where coal can be delivered cheaply and conveniently, the energy being transmitted by means of cables to the different points where power is required, and then employed to drive motors of different sizes and types. The same generating station, but usually a different set of plant in the station, can be employed for generating current for the lighting service all over the works. In order, however, that power shall be distributed economically to the different points of consumption, it is necessary that the electric current shall be generated economically. That is to say, the minimum quantity of fuel, or, to put it in another way, the minimum generating cost that is possible, must rule, and in order to accomplish this, every part of the generating plant must be of the very highest possible efficiency, and every advantage must be taken of the appliances now on the market for economizing fuel consumption. It will be understood, also, that any source of power, wind, water, coal, or oil that can be arranged to drive a dynamo, can be made use of.

The Possibility of using Water Power

One of the most important matters in connection with economical generation of electricity is the position of the generating station. For nearly all coal and iron works, coal will naturally be employed as fuel, but there will be a few cases, very few in the United Kingdom, where it will pay to employ water power that may exist in the neighbourhood, to generate electric currents for lighting the mine

and for the power service, the whole of the coal raised being sold. There is at least one case on the Continent of Europe where this is done, though the conditions are very different from anything that exists in this country. Still, as the author hopes that this book may be of use to mining engineers in other countries, where water power is more abundant than in this country, it may be of interest to discuss the question. In every case of this kind, in fact, in every engineering problem, there is one rule which should govern the use of apparatus of different kinds, viz. the balance sheet. In the present instance, even in the most favourably situated collieries, there will be a certain residue of coal which can be used to fire the boilers, unless it can be sold for more than the power which is to take the place of the steam it would generate will cost. It is often supposed that water power costs nothing. Mining engineers will know very much better than this, because they frequently have to pay high prices for water for their boilers. The reason for the high price of water for colliery boilers is not exactly the same as the reason that water power costs something, but part of the reasons for one are the reasons for the other. Water power can only be employed when it can be stored in sufficient quantity, in reservoirs or ponds, to insure that there is a supply of water for driving the water-engines at all seasons; unless some river can be tapped at a high level, and the water allowed to run through the water-engine to a lower level, as is done so frequently in those parts of America where there is no coal. In either case there is the cost of making the reservoir, the canal or pipe line which is to lead the water to the water-engine, and there is frequently the cost of the electrical transmission line to the point where the power is required. The cost, then, of water power which has to be reckoned in the balance sheet is the interest on the cost of making the reservoir, the canal, pipe line, shafts where they are required, as at Niagara, together with that on the water engines and power house and transmission line. On the other side of the balance sheet would be placed the cost of fuel and water which has to be paid for, together with the interest and up-keep of the boilers, engines, and accessories, or, as explained, the value of the coal that would have been employed for raising steam. In striking the balance sheet where water power is to be employed, when it costs less than the coal it is to displace, the balance sheet will include on the water side the interest and up-keep on the water engine and accessories, and the interest on the transmission line, less the interest on the steam plant. If the difference between these is less than the fuel displaced can be sold for, and there is a market for it all the year round, while water power is sure all the year round, it is economical to employ the water power. Unless this can be insured it is not economical.

How the Water Power is measured

Before it is decided to employ water power, however, it is always as well to know that there is sufficient energy in the water available. There is very often a very hazy idea as to what is required. Water power follows the same laws as every other source of energy. 33,000 lbs. of water falling through 1 foot in one minute, or any equivalent numbers, say 33 lbs. of water falling through 1000 feet in one minute, will furnish 1 H.P. A gallon of water weighs 10 lbs., therefore 100 gallons of water falling through 33 feet in one minute will furnish 1 H.P. The first thing, therefore, to be done is to measure the quantity of water available, and the measurement must be taken at the most unfavourable time of the year, when the quantity of water is least. Full instructions are given for the measurement of the water passing in any stream, or available at any point, in the books on Hydraulics. The measurement is a somewhat troublesome process, requiring a certain amount of skill to perform accurately. It depends upon the actual measurement of a certain cubical content of water passing over a certain space in a certain time. But this is only the commencement of the problem. Having obtained the quantity of water that can be depended upon at all seasons of the year, the weight of the quantity passing per minute multiplied by the distance through which it falls, gives the total possible energy available from that source. But care must be exercised in seeing that the distance through which the water falls is measured, or estimated on practical lines. That is to say, that distance only that can be used in the water engines must be taken as the fall. In the case of a waterfall such as Niagara, or the Victoria Falls on the Zambesi, where Nature has thrown a dam across the rivers which those falls intercept, the total height of the fall cannot be used in the calculation, because some portion of the height must be left for the water which has passed through the water engine, and that has done its work, to get away freely, without forming eddies, as these may set up back pressures in the water engine itself. Similarly, where the river is dammed, and a canal or a pipe line is taken from the side of the dam to some convenient point, and there connected to the water engine, the water being allowed, after passing through the water engine, to find its way into the river below, or into some other river, as in the case of the St. Lawrence and its tributary the River Grasse, the total height, the total distance that can be employed in the calculation referred to above, is the difference between the vertical height of the dam at most *unfavourable* seasons and that of the water in the tail race, as the conduit or passage which carries away the water which has done its work in the engine is called. And there

is another thing to be looked out for in this matter. In times of drought the water will be low in the reservoir, or the upper part of the river from which it is taken, and the available fall will be smaller from this cause than when the river is full. On the other hand, in times of flood, while the rise of the river at first will increase the available fall; after a certain time, if the flood goes on, the water in the lower part of the river and in the tail race also rises, and the available fall is again reduced from that cause. Having, however, obtained the available quantity of water passing per minute under the most unfavourable conditions, and the available height through which its fall can be taken, also under the most unfavourable conditions, the power obtainable is a certain fraction of this, depending upon the efficiency of the water engine. The efficiencies of water engines vary from 40 per cent. to 87 per cent. In addition to this, there will be the charge made by the electrical generators for converting the mechanical power of the water engine into the electrical power; there will be the charge made by the electrical conductors for transmitting the power from the place where it is generated to the place where it is to be consumed, say to the mine; and in nearly every case there will also be a charge at the point of consumption, made by some apparatus for converting the current from a high to lower pressure. In the great majority of cases it will be necessary to generate current at the water-power station at a comparatively high pressure, in many cases to transform it up to a very high pressure, 10,000 volts or more, in order to keep the size of the transmission conductors down, and it will then be necessary to retransform the high-pressure current to lower pressures for use at the mines, etc.

Forms of Water Engines

The author does not propose to enter very much into the details of water engines in this book. As explained, the water must be stored unless Nature has done the work, as in the great lakes above Niagara, or in the great rivers from which power is taken in America, India, and elsewhere. The water must be taken by iron or wood pipes, troughs, conduits, canals, or any other convenient method to the water engine, and provision must be made for delivering the water to the engines, for regulating the quantity passing into each particular engine, and for allowing the water to run away freely after it has done its work. There are practically three forms of water engine: the water wheel proper, which was so much used by the sides of the old mill streams in the United Kingdom before the advent of coal; the turbine, which came into being for the purpose of utilizing small quantities of water falling from great heights, as in Switzerland and

elsewhere; and the water engines of the type of the Pelton water wheel, which may be considered as something between the large water wheel and the turbine. The large water wheel and the water turbine correspond roughly to the slow speed and high speed steam engines. The large water wheel has usually a very large diameter, and it revolves at a very slow rate, sometimes only a few revolutions per minute. Power is obtained in one form of wheel by allowing the water which has been brought down by the pipe line, or canal, to fill buckets which are carried at intervals on the periphery of the wheel. The weight of the water in the bucket falling through a vertical height, corresponding to a portion of the diameter of the wheel, delivers the energy liberated by its fall to the periphery of the wheel, causing the wheel itself to revolve in the process. As there is always a bucket coming under the mouth of the pipe line, and one or more buckets always falling from that position to the bottom of the wheel pit, the motion is continuous, and the useful energy the wheel is able to deliver is made up of the sum of the energies delivered by the active buckets during any revolution, less the charge made by friction, and by the eddies in the tail race. In another form of wheel, the pressure of the water, that is to say, the weight of the water column above that which is actually impinging on the wheel, is made to act upon successive projections of the wheel and to force it round. As there is always one of these projections, either actually in front of the stream of water or coming to it, the action of the water upon the wheel is continuous, and the motion of the wheel itself is continuous. The energy available at the wheel shaft is that of the pressure of the water column, that is to say, the weight of the column of water above the wheel, multiplied into the actual quantity of water passing per minute, less any water that may be wasted, less also the friction of the wheel and any back pressure created by eddies. In the turbines, of which there are various forms, there are always a number of curved blades surrounding a central shaft, and the column of water is made to impinge upon each of the blades in succession. The water sometimes flows outwards from the centre, and sometimes inwards, the latter giving the highest efficiency. A portion of the force of the water acts in the direction of rotation of the shaft, and as there is always a blade receiving the force of the water, the motion is continuous, and the energy available at the shaft of the turbine is that portion of the energy of the water which is resolved in the direction of the rotation of the shaft, less the friction of the shaft and of the blades, and less any back pressure created by eddies, etc. This is hardly the place to go into the question of the construction of turbines, but it may be mentioned that the efficiency of the turbines depends very much upon the form of the blades. What is required is, that the blade

shall be of such a form as to convert the largest possible portion of the force delivered to it into rotary motion of its shaft, and to deliver the water which has done its work upon the blades in such a condition that, on the one hand, as much of the available energy as possible has been taken out of it in passing through the turbine, and, on the other hand, that the water escaping from the apparatus shall not be able to set up eddy currents which would reduce the efficiency of the apparatus.

Short Description of Pelton Wheel

In the Pelton water wheel there are a number of buckets, arranged round the periphery of the wheel in the usual way, but the buckets are of a peculiar form. Practically, each bucket consists of two, connected at the middle, and the water is delivered against the buckets in the form of jets, from nozzles, something after the manner of the nozzles of the De Laval and other steam turbines. The jet of water divides between the two halves of the bucket, and is deflected to both sides out of the way of the wheel, the result being a very high efficiency. It is known as the tangential wheel. Any one of the water engines described may be used to drive electricity generators, either by coupling the axles of the water engines with the axles of the dynamos, or by driving the latter by belts or ropes.

Steam Plant

As already mentioned, coal will in the great majority of cases be the source of energy for lighting and power in mines. There are two methods of obtaining the energy of the coal—by burning it in the furnace of a boiler to generate steam, and by using it to generate gas in a producer. There are two principal forms of boilers, known respectively as the Water Tube and Fire Tube, the latter being more generally known as Lancashire, or Cornish, or marine type boilers. The Lancashire type of fire-tube boilers is more generally used than the others. The principal distinction between the two forms of boiler is, in the water-tube boiler the water which is to be converted into steam circulates inside of tubes arranged for the purpose, connected with drums for steam, and for water, as will be explained, the gases from the boiler furnace playing around the outside of the tubes. In the fire-tube boiler the gases from the furnace are made to pass through tubes or flues while the water circulates in the containing vessel around them. In the Lancashire boiler, which is long in comparison with its diameter, and cylindrical in section, there are two tubes or flues extending the whole length of the

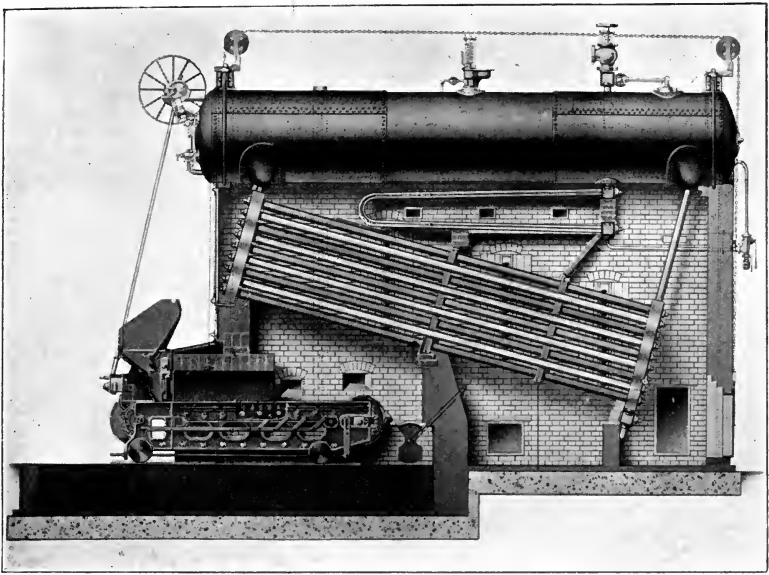

PLATE 1A.—Section of Babcock & Wilcox's Water Tube Boiler, with Chain Grate Stoker and Superheater. The Superheater is the Coil of Pipes above the Boiler Tubes.

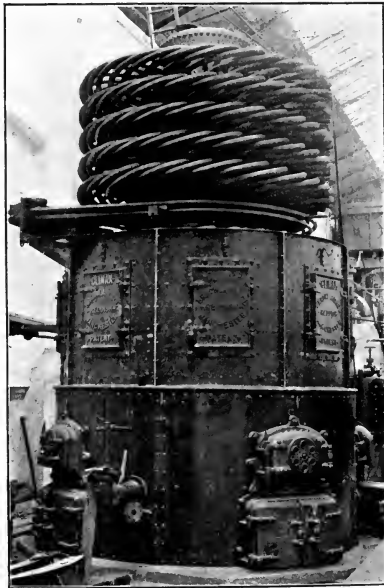

PLATE 1B.—“Climax” Boiler as made by Messrs. B. Rowlands. The Coil at the Top is a Portion of the Boiler Tubes.

boiler, and occupying a large portion of the available space, and the gases which are generated by the combustion of the coal pass through these flues on their way to the chimney. In Messrs. Galloway's modification of the Lancashire boiler, the long tubes described above are broken up by cross tubes. The object of this arrangement is to increase the heating surface, where the hot gases and the water are brought close to each other. In a later form of Lancashire boiler, the main flues have a number of small tubes arranged vertically, breaking up the space. In the Cornish boiler, also cylindrical in section, there is usually one large cylindrical flue in the centre of the containing vessel, through which the hot gases pass, and around which the water circulates, as in the Lancashire boiler. In both forms of boiler, external flues are formed between the outside of the boiler and the brickwork in which it is set, the hot gases passing through them on the way to the chimney. The Cornish boiler has gradually given way to the Lancashire boiler, principally because of the greater heating surface the Lancashire boiler is able to expose, and also from the fact that the Lancashire boiler more readily lends itself to the storage of heat by reason of the larger quantity of water it holds. In the marine boiler, which is another type of fire-tube boiler, designed originally, as its name implies, for marine work, there are a number of small tubes through which the hot gases pass, the water occupying the space between the tubes. The tubes form more or less of a nest. Messrs. Davey & Paxman make a form of this boiler, shown in Fig. 53, for use on land. It is used in electricity generating stations. In all types of steam boilers there is some form of furnace which may either be completely outside of the vessel forming the boiler, or which may form part of it. The furnace is simply a long grate consisting of fire bars, upon which the coal or other fuel that is to be consumed rests, with an ashpit below, into which the ashes fall, and having at its inner end, the end removed from the entrance to the furnace, a bridge usually formed of firebricks, over which the hot gases pass, the bridge itself being raised to a white heat, and performing an important part in the work of combustion. At the front or entrance to the furnace are doors, usually arranged in pairs, sliding together and meeting in the centre. In all types of boilers, one of the most important things is to make the hot gases deliver up as much of their heat as possible to the water from which steam is being generated, and in order to accomplish this, the gases are caused to traverse as long a path as possible on their way to the chimney, passing over different parts of the heating surface in succession. In the Lancashire and Cornish boilers this is accomplished by making the surface over which the gases pass as large as possible. In the marine type the object is accomplished by breaking up the flue into a number of small surfaces, as explained. There is

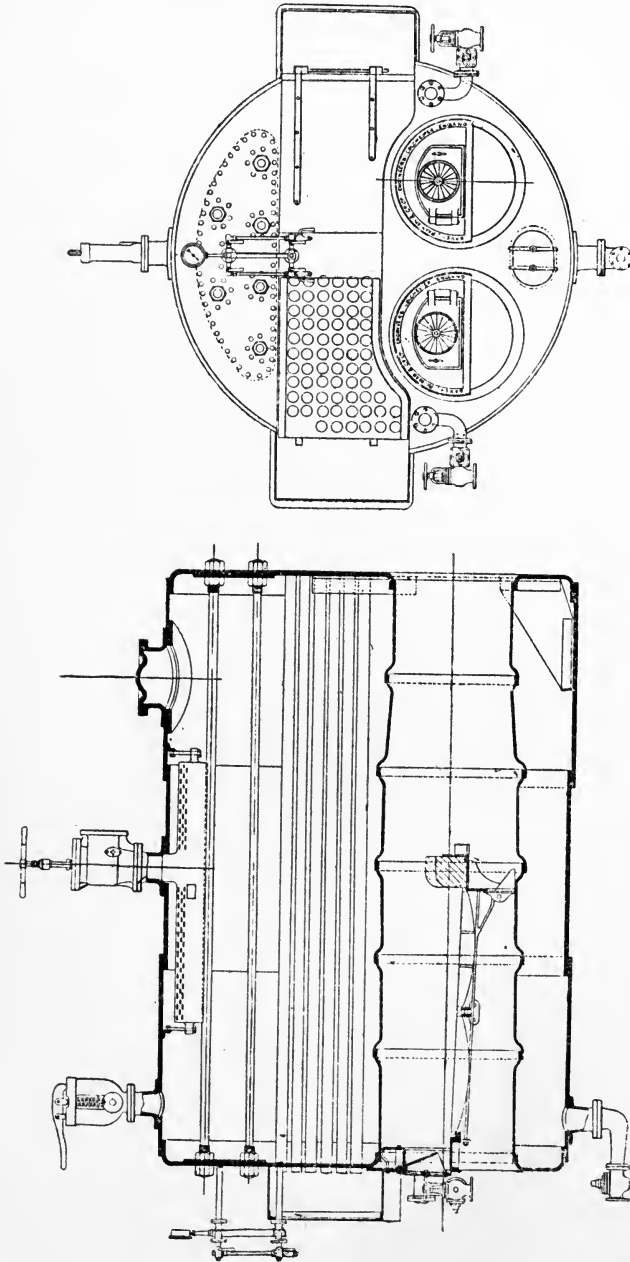

FIG. 53.—Longitudinal and Transverse Sections of Messrs. Davey & Paxman's "Economic" Boiler, in which a number of Fire-tubes are employed, on Similar Lines to the Marine Boiler.

an important point in connection with the matter of the passage of the hot gases through the flues, and that is, the hot gases obey the laws to which all fluids are subject in passing through tubes, etc., and create friction where they rub on the surface of the tubes through which they pass. The friction created varies directly as the extent of the surface over which the gases have to pass, and as the square of the velocity at which they are travelling, hence the large flue in the Cornish boiler was thought to have an advantage over the smaller flues in the Lancashire boilers, because the flow of the gases was necessarily throttled less in the larger tube, and therefore, as in all similar cases, the velocity in passing through the flues would be less. The question, as in many similar cases, is a very difficult one to decide, because it is so difficult to obtain exact figures, but practice appears to have decided the question in favour of the Lancashire boiler. In both Lancashire and Cornish boilers the gases are frequently given an additional run, through flues formed between brickwork built round the boiler, and its outside shell. In the water-tube boiler the same effect is attained as in the Lancashire boiler, by interposing a series of baffles in the path of the gases on their way to the chimney. The gases passing from the back of the furnace are made to run over the surfaces of a portion of the tubes, and are then deflected by a baffle over the surfaces of another set of tubes, and so on, so that the whole of the tubes contained in the boiler are subject to the action of the gases.

Forms of Water-tube Boilers

The Babcock & Wilcox.—In the Babcock and Wilcox boiler, shown in Plate 1A, there are rows of tubes inclined at an angle of about 30° from the horizontal running from front to back of the boiler space. The tubes slope downwards from front to back, and each end of each tube is expanded into a header. The headers are the junction pieces between the tubes, and they connect to the end tubes at front and back leading to the steam drum. At the front a number of short tubes lead from the top of the header to the under-side of the steam drum; at the back a number of longer tubes connect the back headers with the back side of the steam drum. The tubes themselves are in stacks, so many deep, and so many wide horizontally, according to the size of the boiler, and the quantity of water it is to convert into steam. The headers at front and back are slightly inclined with a vertical. They are at right angles to the boiler tubes. Above the tubes themselves is the steam drum. In some cases there are two or more steam drums. The office of the steam drum is to act as a reservoir, both of water and steam. The water is kept circulating continually through the tubes, through the headers into the steam

drum, back to the headers through the tubes again, and so on. At each passage through the drum a certain quantity of steam is delivered up, the steam rising above the water in the drum in the usual way, and being carried off by the steam pipe. The boiler tubes are arranged in the manner described, expanded into the headers, which are practical boxes with divisions, in order that in case of any boiler tube developing a leak, or not doing its work properly in any other way, it may be disconnected. The space for the hot gases, which play all round the boiler tubes, is provided by brickwork, which is built into a steel skeleton framework from the floor to the steam drum, and enclosing the rectangular sectioned space inside, containing the boiler furnace and the ash pit. The outside is formed of white glazed bricks, the object being to reduce the loss by radiation. The front portion has built into it the ashpit door at the bottom, the furnace door just above it, and a door above that, giving access to the front headers of the boiler tubes. The furnace of the boiler, consisting of the usual fire bars, occupies the usual space just inside the furnace door. There is the usual bridge of firebrick, just behind the fire bars, and beyond that, at different points within the space occupied by the water tubes, are firebrick baffles, arranged to direct the hot gases generated in the furnace successively over each section of the boiler tubes. In the later forms of Babcock & Wilcox boilers, a superheater, consisting of a number of small tubes through which the steam passes on its way from the boiler to the engine, is fixed in the triangular space left vacant between the upper side of the boiler tubes and the tubes rising from the headers at the back, as shown in Plate 1A.

The Stirling Water-tube Boiler.—The Stirling water-tube boiler has been made in two forms, with four and five drums respectively, as shown in Fig. 54. In all forms of this boiler there are three drums at the top. In some forms there are two drums at the bottom, and in others only one. In all forms the water tubes themselves are nearly vertical, those near the front of the boiler being inclined about 30° from the vertical, those in the next batch slightly less, and those in the rear batch very little out of vertical at all. There are always three lots of tubes. The front lot of tubes connect the front drum at the top with the front drum below where there are two, or with the common drum where there is only one. The next lot of vertical tubes connects the middle drum at the top with one of the drums below, and the rear lot of vertical tubes connects the rear drum at the top with the rear drum below where there are two, and with the common drum where there is only one. The drums, both at the top and bottom, are connected together by transverse tubes. The middle drum at the top is the one from which steam passes to the steam pipe. The rear drum at the top is the one to which the feed water is applied, from which it passes to the rear drum below where

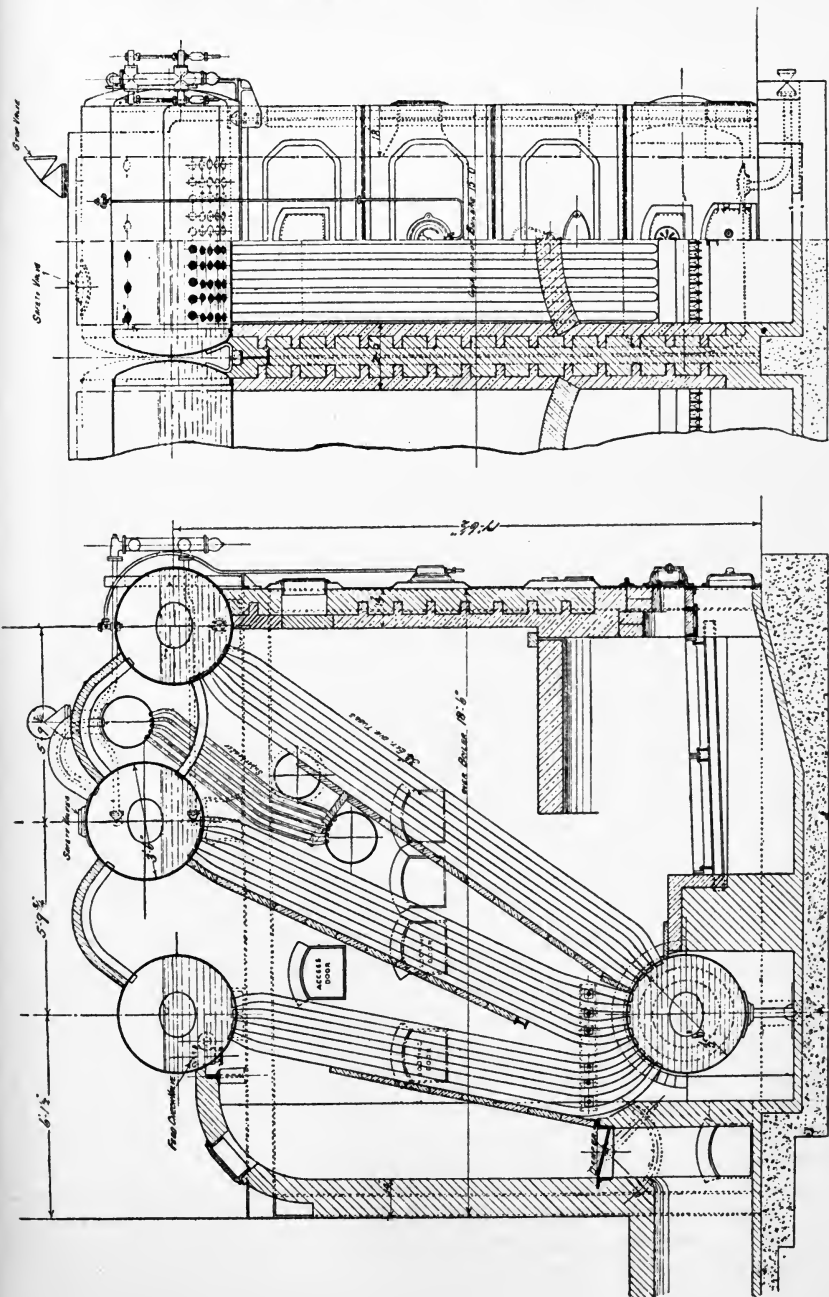

FIG. 54.—Longitudinal and Transverse Sections, with Part of the Front Exterior, of a Four-drum "Stirling" Boiler with Superheater.

there are two. The object of the lower drums, in this form of water-tube boiler, is to get rid of any foreign matter, dirt, etc., that may come in with the feed water, it being deposited at the bottoms of those drums, from which it can be carried off. The water from which steam is being generated circulates continuously through the different lots of tubes, from front to rear, and *vice versâ*, steam being delivered to the two upper front drums in the process. The arrangement of the furnace and the space for the hot gases is very similar to that in Babcock & Wilcox, the whole being enclosed by firebricks with white glazed bricks on the outside, the drums being built into the top. As in the Babcock boiler, there are baffles placed at different parts of the hot gas space to direct the hot gases over the whole of the surface of the boiler tubes, thus the hot gases pass up over the front section of the tubes, thence across to the top of the next section, down that section, across to the third section, up that section, across to the top of the fourth section where there are four sections of tubes, down that section, and away to the chimney. The front of the boiler is occupied as usual by the ashpit door, the furnace door, and a door by which access is obtained to the gas space. It is claimed on behalf of the Stirling boiler that the steam in the front section of pipes—the water has become steam when it reaches this section—is practically superheated while passing up through these tubes, in the same way as in passing through a separate set of superheated pipes.

The Hornsby Water-tube Boiler.—In this boiler the tubes are fixed something on the lines of those in the Stirling boiler, but with an arrangement different in many respects. In the Stirling boiler, as will be seen from the drawings, the tubes are curved where they approach the drums, both above and below. In the Hornsby boiler the tubes are quite straight, and they are expanded into headers at top and bottom, consisting of cylinders arranged to take the tubes. The tubes are arranged in batches, a certain number of tubes with the header cylinder at top and bottom forming an element, and the number of tubes in each element and the number of elements being varied according to the work the boiler is intended to perform; that is to say, the capacity of an individual boiler may be increased by adding more banks of tubes or by making the individual banks larger. The upper header cylinders are longer than the lower cylinders; with the exception of those belonging to the bank of tubes at the back of the boiler. These header cylinders, to a very large extent, perform the office of the drums in the Stirling boiler, the lower drums acting as mud or dirt receptacles, and the upper assisting to equalize the steam pressure. The banks of tubes are all inclined about 30° from the vertical, except the one bank at the back of the boiler, which is quite vertical. There is a steam drum fixed between the upper header

cylinder of the rear bank of tubes, and the upper header cylinder of the rear one of the inclined banks; and a steam drum is connected with the upper header cylinder of the rear bank, and those of the front banks by pipes in a similar manner to the Stirling. As with the other water-tube boilers, the whole of the tubes, furnace, etc., are enclosed inside the firebrick space with white enamelled bricks on the outside, but, in addition, both the upper cylinder headers and the steam drum are inside the iron or steel framework. The furnace, as usual, is placed in the front with the usual firebrick bridge, and the gases are conveyed by means of baffles up the front of the first bank of inclined tubes, across the upper part of the first bank to the second bank, down the front of the second bank, across the lower part of the second bank to the lower part of the third bank, up the front of the third bank by a somewhat tortuous course, first from front to rear, then from rear to front, then from front to rear again, and thence to the flue.

Thornycroft Water-tube Boiler.—Messrs. Thornycroft have developed forms of water-tube boilers on lines of their own, especially intended for use on board ship; but they have also been used on shore, and there appears to be no reason why they should not be. The principal feature of the Thornycroft boiler is the division of the water tubes into a very large number of very small tubes, in some cases as small as 1 inch in diameter, and in the majority of cases not greater than $3\frac{1}{2}$ inches. In one form of Thornycroft boiler, there are two drums at the bottom and one at the top, and the small tubes mentioned connecting the bottom tubes and the upper tube inside an outer casing, which is of iron or steel in marine boilers, but which may be of firebrick for shore boilers, and the upper and lower drums are connected outside of the casing by very much larger tubes. The upper drum contains steam and water, and the lower drums water only. The water passes directly, by gravity, from the upper drum to the lower drums, meeting with very little resistance on its way. It then commences to move up through the nest of small tubes to the upper drum, bubbles of steam being formed as the water ascends, the water and steam finding their way into the upper drum, the steam being delivered to the steam space, and the water reinforcing that already in the drum. The small tubes are bent into the form of an arch over the furnace, and there subjected to the hot gases arising from the furnace which pass over and between the tubes, and finally escape to the chimney. A sort of wall is formed on the outside of the tubes, inside the casing, by two rows of tubes placed very close together. There are several variations of this form of boiler, but the above are the main lines. The idea, it will be seen, is to divide the water up as much as possible, and to provide that a small quantity is always close to some portion of the flue

gases, and only separated from them by the thickness of the pipe. In another form of Messrs. Thornycroft's boilers, there is one steam-and-water drum at the top, and at the back there is a vertical water tank from which tubes are brought to the front of the boiler, where they are connected in pairs by junction pieces, the junction pieces and the water tank taking the place of the headers in the Babcock boiler. The tubes in one form of this boiler are staggered, and the furnaces are right underneath the lowest of the tubes, so that the hot gases rise between the tubes, the particular arrangement of which causes them to act in the same manner as the baffles described in connection with other boilers, and to direct the hot gases to all parts of the tubes. The water circulates through the tubes and their connecting-pieces and the water tank, steam as it is formed gradually rising in the water tank and passing by the upper tubes to the steam-drum. In another form of Messrs. Thornycroft's boiler the arrangement of the tubes is slightly different, and there is no water tank. The boiler is made in sections, each section consisting of a certain number of tubes placed vertically one above the other, expanded into vertical headers at the front end of the boiler, and joined to corresponding tubes of the next section of the boiler at the rear end. The alternate sections of the boiler are arranged at different inclinations, thus the tubes of the section on the extreme left may be inclined to the horizontal at about 15° , the front being below the back, while the next sections are inclined upwards about the same number of degrees. The headers in the front are connected to the steam drum, and there is a continual circulation of water through the pairs of sections of tubes, the steam as it is formed being disengaged in the front headers and escaping into the steam-drum. The furnace lies right under the tubes, and the gases escape between the different sections.

The Nielausse is a French boiler, which was taken up and manufactured by Messrs. Willans & Robinson. It is rather like the Babcock in many respects, and has been largely used in the French navy. The principal feature of it is the arrangement of the tubes. These are inclined slightly to the horizontal, are expanded into headers in the front, but are only held at the back, not expanded into headers, the arrangement consisting of one tube inside another, the water going down the inside tube and returning by the annular space between the tubes. So far as the writer is aware, the Nielausse boiler has not been much used in this country.

The Climax is an American boiler, and is in use in a considerable number of electrical generating stations in this country, and in a very large number of works of all kinds in America. In this boiler a distinctly new line has been struck. It is essentially a water-tube boiler, but the tubes are of very peculiar arrangement and construction.

Looking at the boiler with the outer casing removed, one would imagine that one was looking almost at a coil of rope. There

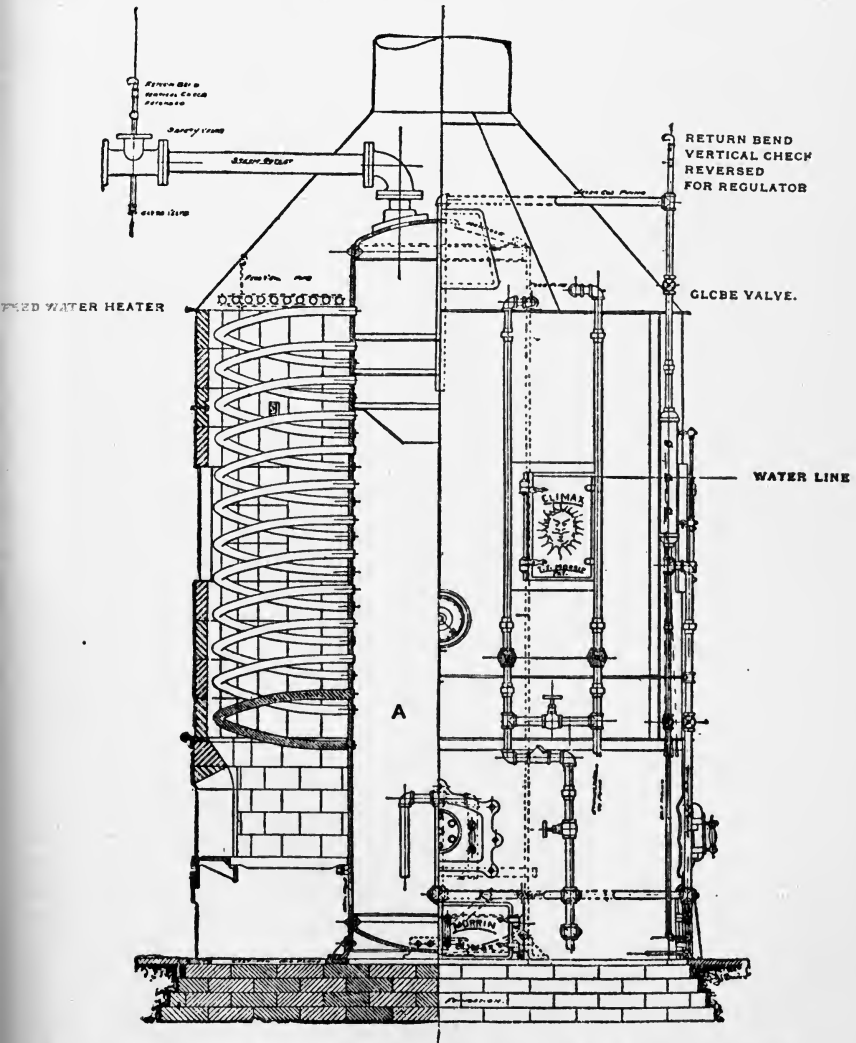

FIG. 55.—Half Vertical Transverse Section, and Half External View of "Climax" Boiler. A is the Central Tube to which all the Spiral Tubes are connected.

is a central vertical cylinder, which passes from the firebox to the steam pipe at the top. This corresponds to the steam drum in other

types. The vertical cylinder has holes drilled in it, in parallel rows, throughout its length, and to these holes are connected the tubes of the boiler, which are comparatively small in section, and are made in a spiral form. Each tube passes from a hole in the vertical cylinder at a certain height, and after performing a certain convolution with the other tubes, enters the vertical tube again lower down. The whole of the boiler forms a vertical cylinder when the casing is on, and the furnace and ashpit occupy the whole of the lower portion of the cylinder, the hot gases passing up and circulating between interstices left by the convolutions of the tubes, and therefore playing over all parts of their surfaces, and passing thence to the funnel. There are four firebrick doors at points 90° apart in the lower part of the cylinder, and the furnace is enclosed inside a wrought-iron casing lined with firebrick. The boiler occupies less floor space for a given evaporation per hour than most boilers. For purposes of cleaning, the outer casing is pierced with doors about 45° apart at different levels, according to the sizes of the boiler, and it is usual to fix galleries at these levels, built of open ironwork, so that any part of the boiler may be got at for cleaning purposes. It is shown in Fig. 55 and Plate 1B.

What Combustion is

Before considering the sources of economy in connection with steam raising, it may be as well to study combustion itself. Coal, as is well known, contains carbon, hydrogen, and other elements, and by combustion we mean the combination of the carbon and the hydrogen with the oxygen of the atmosphere. The combination of carbon with oxygen liberates heat, 10,000 heat units approximately per pound of carbon, when one atom of carbon combines with one atom of oxygen to form carbonic oxide, and a further 4000 heat units approximately when the carbonic oxide combines with a second atom of oxygen to form carbonic acid, or the whole 14,000 units will be liberated when the carbon unites with the two atoms of oxygen at once, and perfect combustion of the carbon is obtained when the whole of the carbon is oxidized to carbonic acid; but in the ordinary working of a boiler furnace this is very rarely accomplished. Some carbonic acid is formed, some carbonic oxide, and some carbon is carried away in a very finely divided state, and appears later as smoke, having contributed nothing to the general heating effect. The combination of 1 lb. of hydrogen with oxygen, in the proportion of two atoms of hydrogen to one atom of oxygen liberates approximately 62,000 heat units, and therefore fuels which are rich in hydrogen have a higher calorific value; that is, they liberate more heat in the process of combustion than fuels which are not so rich. This is one reason why petroleum

has a higher calorific value, for equal weights, than coal. But the above does not represent the whole case. Coal very rarely consists simply of carbon and hydrogen. Oxygen is also nearly always present, and very frequently other substances, such as sulphur, and what are generically known as dirt. The oxygen contained in the coal practically represents a certain loss of calorific value, inasmuch as it will absorb a certain quantity of hydrogen, the combination forming water in the usual way, every atom of oxygen absorbing two atoms of hydrogen, the number of atoms of hydrogen thus absorbed in satisfying the demands of the oxygen contained in the coal being lost, so far as heating value is concerned. In addition, when coal contains sulphur, that also absorbs, or may absorb, a certain quantity of hydrogen, forming sulphuretted hydrogen, the effect of which upon the final calorific value is doubtful. Where dirt is carried in the coal, it absorbs a certain quantity of the heat liberated, in proportion to its weight and its specific heat. The dirt, using the term to mean substances that cannot be usefully burned, that do not combine usefully with oxygen, unless they are carried harmlessly into the ashpit, and until they are carried there, or are carried up the chimney, must necessarily be made to assume the temperature of the bodies surrounding them, and in so doing must absorb heat from the hot gases that are formed, and so take from the useful heating effect of those gases. When the coal is burned, the gases which are formed are raised to a very high temperature, and it is these hot gases which are made to pass through the flues and pipes and over the tubes described above, and which deliver a portion of the heat which has been delivered to them, to the metal surfaces over which they rub, the heat being conveyed from the metal plates to the water which is moving over the other sides of the metal plates or tubes.

The British Thermal Unit

Perhaps before going any further we had better understand what is meant by the heat unit, or, as it is termed in scientific phraseology, the British Thermal Unit. It is the standard which is adopted for all measurements in which the transference of heat from one body to another takes place. The British Thermal Unit is that quantity of heat which will raise the temperature of 1 lb. of pure water, at its maximum density 39.2° Fahr., 1° Fahr. Strictly speaking, the quantity of heat required to raise the temperature of 1 lb. of water 1° Fahr. increases slightly as the temperature of the water increases; that is to say, the quantity of heat required to raise the temperature of 1 lb. of water at, say, from 80° Fahr. to 81° Fahr. is a little more than that required to raise its temperature from 39° Fahr. to 40° Fahr. For practical purposes, however, the quantity of heat

required to increase the temperature of 1 lb. of water through each successive degree Fahrenheit between freezing-point and boiling-point of water is taken to be the same, and this quantity is taken as the standard. The specific heat of any substance is the ratio between the quantity of heat required to raise 1 lb. of the substance 1° Fahr., and that required to raise 1 lb. of water 1° Fahr. The specific heat of water is taken as unity, and as the specific heats of the great majority of other substances are less than that of water, they are usually written as decimals. The specific heat of air, for instance, is 0.238 at constant volume, and 0.169 at constant pressure. This matter will be dealt with later. The matter of the heat unit, it will be found, will follow us through almost every problem that we shall discuss in the course of this book. The British Thermal Unit has its direct mechanical equivalent; that is to say, the energy in one heat unit is equivalent to the energy of 778 foot-lbs. We shall find later on, when discussing the problems involved in electrical distribution, that the heat unit will come up again. The electric current delivers heat to the conductors through which it passes in definite quantities, each electrical unit delivering a certain fraction of a heat unit, and so on.

But in following the course of the increase of temperature of water and its conversion into steam, we have to take notice of another property, known as *latent* heat. If we take 1 lb. of water and apply heat to it, raising its temperature degree by degree, we find that approximately one heat unit is absorbed for every degree of increase in temperature, but when steam commences to be formed from the water, the temperature of the steam and of the water remain exactly the same, 212° Fahr. at ordinary barometric pressures, until the whole of the pound of water has been converted into steam, and the conversion of the pound of water into a pound of steam at atmospheric pressure absorbs 966 heat units, and this is the *latent* heat of steam at that pressure. At the other end of the scale, when water is frozen, there is a very similar operation, but in the reverse order. If we wish to freeze a pound of water, we have to abstract from the water the *latent* heat of the *liquid*, which is 142 heat units, and while the process of abstracting the heat units is going on, the temperature of the water and the temperature of the ice which is being formed from it remain the same, -viz. 32° Fahr. at ordinary atmospheric pressure. When all the water has been converted into steam, the temperature of the steam rises and also its pressure, as will be explained, unless the steam is able to escape and expend the energy that has been delivered to it. Similarly, after the whole of the water has been frozen, if the process of abstraction of the heat is continued, the temperature of the ice itself is lowered. The temperature of the natural ice which is formed in rivers, glaciers, etc., is usually a great deal below freezing-point, and the ice which is

formed artificially by refrigerating machinery is also usually made a good many degrees below freezing, so that it may remain firm and solid, and not become sloppy. It was mentioned above that the combination of 1 lb. of carbon with oxygen in the proportion of one atom of carbon to two atoms of oxygen liberated approximately 14,000 heat units. These are the British Thermal Units just described. It will be seen, therefore, that there is a direct connection between the combustion of coal and the raising of steam. By the combustion of coal, a certain number of heat units are liberated, according to the composition of the coal. These heat units are delivered to the gases which are formed in the process of combustion, and a portion of the heat delivered to them is passed on to the water in the tubes, or, surrounding the tubes, in the boilers. The great object the boilermaker has in view is, the transmission of the largest portion of the heat present in the gases produced by combustion, to the water, and to the steam in the boiler. As with all machinery, under the very best conditions, the whole of the heat cannot be transmitted to the water; and in practice, what is known as the efficiency of the boiler, that is to say, the proportion of the heat liberated that is transmitted to the water is comparatively small, and for various reasons. The calorific value of coal varies from 5000 units per pound of coal for brown coal lignite, and similar coals up to 14,000 heat units per pound for best anthracite. By calorific value is meant the number of heat units obtained by the combustion of 1 lb. of coal in oxygen. The standard value for calculations is taken at 10,000 heat units per pound of coal. In describing the process of combustion above, the quantities of heat liberated by the combination of a pound of carbon, and a pound of hydrogen with oxygen respectively, was given; but those figures were on the assumption that pure oxygen was available for the process of combustion. In practice the oxygen of the air, which is diluted with approximately four times its weight of nitrogen, a perfectly inert gas, is used in combustion, and the quantity of nitrogen which is admitted to the furnace with the oxygen of the atmosphere, has also to be heated to the temperature of the other products of combustion, carbonic acid, etc. And here it will be seen where the value of the knowledge of specific heat and the use of the British Thermal Unit comes in. Nitrogen has a specific heat of 0.2754, and therefore every pound of air which is delivered to the boiler furnace brings with it approximately four-fifths of a pound of nitrogen gas, demanding four-fifths multiplied by 0.2754 for every degree that its temperature is raised. As the furnace temperature is usually in the region of 3000° Fahr., every pound of air admitted to the furnace brings with it, in the nitrogen forming part of it, a demand of 638 heat units to raise the temperature of the nitrogen to that of the other bodies surrounding it, and this

number of heat units is taken from those which are liberated by the combustion of the coal. And this is only one of the sources of loss of heat which takes place in the boiler furnace. Theoretically, 12.2 lbs. of air are sufficient for the combustion of 1 lb. of carbon, but it is found necessary to admit from 18 to 22 lbs. of air per pound of coal consumed with ordinary chimney draught. As the carbon and hydrogen of the coal can only combine with the definite quantities of oxygen that have been named, the nitrogen remaining over from the air, from which the oxygen of combustion is taken, and the whole of the surplus air supplied, all demand heat from that liberated by the combustion of the coal, to raise them to the temperature of the surrounding bodies. The air and the free nitrogen gas which is so heated, form part of the hot gases mentioned above, as passing through the flues and round the pipes, and doubtless take their share of delivering heat to the metal surfaces over which they rub; but the point is, the transmission of the heat from the coal to the metal surfaces could have been accomplished quite well by the carbonic acid gas formed, if complete combustion had been attained, and if no diluent had been present. In addition to this, there is another peculiar action. However carefully coal may be handled, a certain amount of dust is formed, and dust is created in the process of stoking, and in the ordinary process of combustion there is a mechanical action of the hot gases passing from the coal on the furnace bars to the flues, somewhat similar to that of a stream of water running, say, through a coal-washing machine. The hot gases carry minute particles of coal, and also minute particles of uncombined carbon with them in their passage, and these particles of coal or of carbon not only perform no useful work in the generation of heat, but they also demand that heat shall be delivered to them, in order that their temperature may be raised to that of the gases in which they are imprisoned, and this heat is also taken from that liberated by the useful combustion of the coal. And there is still another source of loss of heat, or rather of demand for heat from that liberated by combustion. The air which is admitted to the furnace is, in the great majority of cases, at a very much lower temperature than the furnace itself. Even where the boiler room is at a comparatively high temperature, an oppressive temperature for the stokers, the air passing into the furnace from the boiler room is a great many hundred degrees lower in temperature than the mass of burning coal on the fire bars, and the first thing which happens when air is admitted, as when the furnace doors are opened for the purpose of stoking, or in connection with the air passing through the ashpit, and thence through the fire bars to the burning coal, is, the air itself absorbs a large quantity of heat, directly in proportion to its weight and to its specific heat, or, say, approximately a quarter of a heat unit

for every pound of air admitted ; and this, again, has to be taken from the heat liberated in combustion. Hence while, on the one hand, there is often a difficulty in obtaining a sufficient quantity of air through the ashpit for anything approaching complete combustion, on the other hand the air entering by the fire doors each time they are opened has a distinct damping effect. The effect of suddenly admitting a volume of air at, say, 80° Fahr. on to a mass of coal at approximately 3000° Fahr. is somewhat similar to the effect of throwing water upon a hot body. It lowers the temperature of the mass of gases just rising from the coal ; it tends to increase the quantity of finely divided carbon coming away ; and so on.

Apparatus for Economizing in Coal and Labour

Mechanical Stokers.—There is a good deal of waste of coal with hand-stoking in the great majority of cases, because whenever the furnace doors are open a quantity of cold air passes into the furnace. When the boiler furnace is fed by hand, no matter how carefully it may be done, there is always a certain quantity of loose coal-dust entering with the lumps of coal, and a large portion of this loose dust is carried off with the hot gases. It is nearly always possible to see when a boiler furnace is being stoked by the sudden excess of black smoke from the chimney. Hence one source of economy is the mechanical stoker. Stoking is an art requiring considerable skill, care, and experience. It is doubtful whether even the best mechanical stokers can compete with a really good, careful stoker who knows his work, and who is handling a good quality of fuel ; but every practical mechanical stoker is very much better than the poor stoker, and is generally better than the average stoker, which is, after all, what the engineer has to work to. In addition, the mechanical stoker enables a very much lower quality of coal to be employed. Even the very best and most careful stoker is not able to avoid waste with low grades of fuel.

Forms of Mechanical Stoker.—The mechanical stoker which is to successfully take the place of hand-firing must perform two distinct functions. It must feed the coal to the furnace in quantities such that the furnace can deal with it and consume it economically, and it must also perform the operations known generally as stoking, performed by the stoker with the shovel and other tools, the object of which is to present different parts of the fuel to the hottest part of the fire in succession, and, by keeping the fuel more or less in motion, to secure complete combustion. There are three main lines upon which mechanical stokers are designed. With all of them the coal is placed in a hopper, directly over the entrance to the furnace, the hopper having a valve where it leads into the furnace, the valve

being opened periodically, and a certain quantity of the fuel being ejected from the hopper on to the furnace bars. In one form of mechanical stoker the bars are arranged in two sets, alternate bars forming one set, and at certain intervals one set of bars is pulled up, the other set being depressed, the rising of the one set and the depression of the other tending to disturb the whole of the fuel upon the bars, and to give it a movement forward. In another form of stoker, the bars are given a jerk periodically, with the same object. Plates 2A, B, C show Hodgkinson's mechanical stoker, which is constructed on these lines. In the Babcock chain stoker a different arrangement rules. The whole of the furnace bars are formed into an endless chain of deep links, what would be breadth in a link of an ordinary chain being depth in the case of the chain stoker. The endless chain passes over rollers in the front of the furnace and at the back, as well as at different parts of its length, so as to reduce friction. The fuel is ejected on to the surface of the chain from the hopper, in the same manner as with the others that have been mentioned, and is gradually carried forward by the motion of the chain itself. The chain is continually moving, so that its upper portion, which forms the fire grate, is moving towards the back of the furnace, and its lower portion, which passes under the fire grate, and which forms the return half of the chain, is moving towards the front of the fire grate.

Natural, Induced, and Forced Draught

It is well understood that it is necessary to have a chimney in connection with a boiler furnace, for the same reason as it is necessary to provide an upcast shaft to a coal-pit. As explained above, for combustion a certain quantity of air must be passed through the coal on the fire bars, to provide the oxygen gas required by the carbon and hydrogen. This air enters by the ashpit and by the fire doors when open, and passes through the coal and the hot gases which are formed, after passing through the boiler flues, enter the boiler chimney and escape at the top. The measure of the difference in weight between the column of hot gases in the boiler chimney, and that of an equivalent column of atmospheric air outside is the "motive column," creating the natural draught by which the supply of air to the furnace is provided. It is therefore necessary that the gases shall be at a certain minimum temperature when they pass into the bottom of the chimney. The case is exactly the same as that of mine ventilation by furnace. But in the majority of boiler installations the temperature at which the gases escape into the chimney, is considerably higher than is necessary to provide

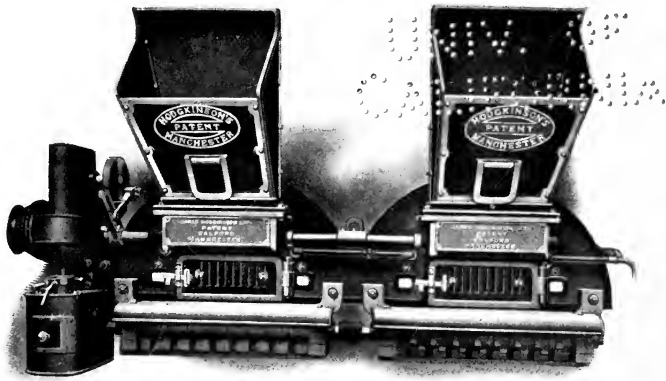

PLATE 2A.—Hodgkinson's Mechanical Stoker. View from Stokehole, showing Hoppers, and Driving Gear.



PLATE 2B.—Hodgkinson's Mechanical Stoker. View from Back of Boiler, showing Furnace Bars. It will be noticed that one Set of Bars are level, while the others have Alternate Bars displaced.



PLATE 2C.—Longitudinal Section of Lancashire Boiler fitted with Hodgkinson's Mechanical Stoker. The Hopper and Gear are seen on the Left.

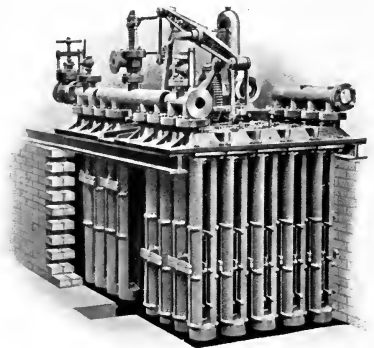

PLATE 2D.—Carter's Economizer, showing the Arrangement of the Tubes, two in each Casting, and the Scraping Apparatus.

[To face p. 104.]

THE UNIVERSITY OF CHICAGO
LIBRARY

sufficient draught, hence a not inconsiderable portion of the heat liberated by the combustion of the coal is carried uselessly up the chimney. In addition to this, the similarity of the problem of providing draught for boiler furnaces, and of providing a ventilating air current for a coal-mine, will have presented itself to mining engineers; and just as mining engineers have displaced the ventilating furnace by a fan, so boiler engineers are gradually moving in the same direction. It will be understood that, as in every engineering problem, it is a question of the balance sheet. If a chimney is depended upon for draught, the cost of creating the draught may be taken to be the interest on the cost of the chimney, plus the amount necessary to be spent on its upkeep and upon clearing out the soot periodically, plus the heat wasted in the hot gases. The chimney may be replaced by a fan, acting either by suction or by pressure, just as the old coal-pit furnace has. With the suction fan, what is called induced draught is employed. The fan is placed near the base of the chimney, and the hot gases are sucked through it, just as the return air is sucked through the fan at the top of the upcast pit. With this arrangement there is no necessity for any special air supply at the front of the boiler, except to ensure that there is always a sufficient quantity available. There is, however, the obvious difficulty attendant upon using a fan through which gases at the very high temperature at the back of the boiler must pass, and that of the constant deposit of finely divided carbon in the air passages. The pressure fan is placed at the front of the boiler, air ducts are laid to the ashpits, and the air is forced into the ashpit and up through the coal on the furnace bars, just as a pressure fan at the top of the downcast pit forces air into a coal-mine. This is called "forced draught." The fan has also been replaced by steam jets. An air duct is placed in the side of the boiler leading right under the furnace bars near the back, and a steam jet is fixed in the centre of this duct, the jet impinging on to the furnace bars above. The steam from the jet condenses on the lower side of the furnace bars, and in doing so creates a difference of pressure between the air at the furnace bars and the air in the boiler house outside, the result being that there is a continual passage of air through the duct, which is bell-mouthed on the inside, and the furnace bars, the effect being the same as that created by either the pressure or the suction fan. In addition to creating a draught, the steam jet exercises a cooling effect upon the furnace bars, thereby reducing their wear. The steam which is at first condensed upon the bars is afterwards re-evaporated, and the heat required for evaporation is taken, as usual in these cases, very largely from the bars upon which the condensed steam is resting. Again, it is a question of a balance sheet between the method of creating a draught by a jet of steam,

and by either of the fans. On the one hand, there is the cost of the steam used, and the interest on the cost of fixing it to the boiler; on the other side is the interest on the cost of fixing the fans and whatever may be employed to drive them, plus their upkeep, and plus the cost of driving them. With either form, however, the height of the chimney may be very considerably reduced. All that is necessary where induced, forced, or steam-set draught is employed is, that the chimney shall be of sufficient height, and its sectional area sufficiently great, to carry off any carbon particles, smoke, etc., that may pass through it, at a height sufficient to prevent their being a nuisance. Where the chimney is already built, as in so many cases, it is not so easy to show an economy by the addition of fans or jets, or other means of providing additional draught. The great drawback to the chimney is, in certain cases, the fact that its ability to create a draught is limited. When all the dampers are out and the chimney is doing its utmost, the draught created is the largest possible without the addition of fans or steam jets. On the other hand, the conditions required for the economical burning of low-grade fuels and of coal-dust and similar substances are that considerable draught shall be obtainable.

Methods of Burning Low-grade Fuel

There are two principal forms of cheap fuel that it will pay colliery owners to burn, if they can do so without increasing the running costs of the colliery in other respects, viz. the coal which is unsaleable, that which exists very often on the outside of a coal seam or between two seams, and the dust which is recovered after washing the coal for coking, and other purposes. There are two methods of burning the bad coal—that which is largely mixed with dirt. One is by grinding it up to a very fine powder and driving it into the furnace in a cloud mixed with air, the other is by burning it simply on special forms of grates provided for the purpose. Messrs. Meldrum of Manchester, who have worked in the refuse destructor field, have developed a form of fire grate which they claim will burn practically any kind of coal, or, in fact, any kind of fuel whatever. The fire bars are made in short lengths of a special section, and fitted very closely together, two or three consecutive bars going to the length of the grate, the bars interlocking with each other. Every method of burning low-grade fuels, or fuel dust of any kind, requires the provision of a considerable draught, very much in excess of that necessary with lamp fuel. In order that the fine dust and the low-grade fuel may be consumed, the air must be brought into contact with every portion of it, and this can only be done by driving air through its mass. On the other hand, the draught must not be

sufficient to carry the dust through bodily. In Messrs. Meldrum's apparatus the draught is supplied by a jet of steam, as explained on p. 105. The steam is provided from the steam chest of the boiler by a pipe arranged for the purpose, but before it is allowed to enter the "blower," as it is called, it is superheated by passing through a tube fixed in the front of the furnace over the dead plate.

The other plan of using dust or very low-grade fuels is, it is placed in a hopper in the same position as the hopper of the ordinary mechanical stoker, and a fan or other apparatus carries it into the furnace. The coal may be ground specially for the purpose, as in the apparatus known as the Cyclone, in which there is a special form of disintegrator, in which the lumps of coal and dirt are torn up by revolving discs, with projections upon them, and the coal-dust produced is cleaned from dirt by centrifugal action. Or the coal-dust may be obtained from the settlings in the water tanks, into which the water that has been used for washing the coal is allowed to run. In the most modern forms of coal-washing machinery, the water, after it has done its work in washing the coal, is passed into tanks provided for the purpose, where the dust which it has picked up

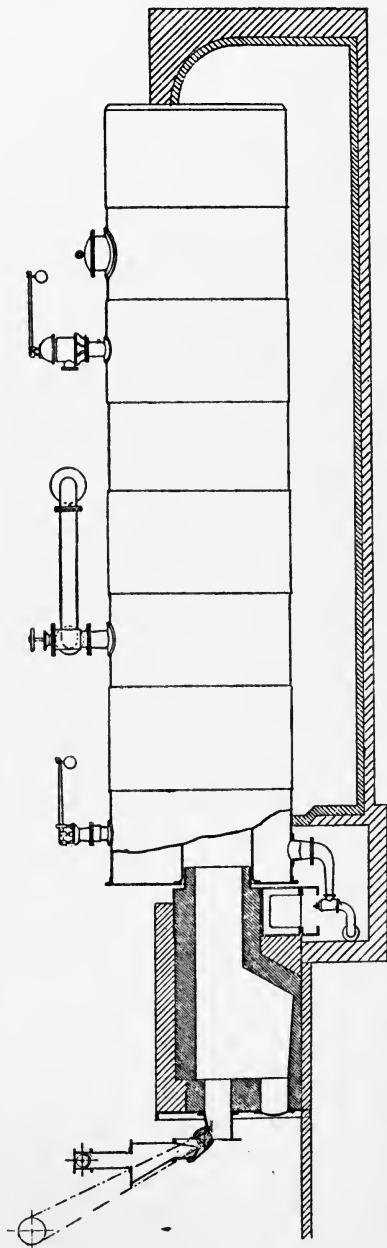

Fig. 56.—Sectional View of Arrangement for burning Coal Dust, in a Lancashire Boiler, by the Schwartzkopf Process. The Hopper is shown on the Left, and the Revolving Brush which delivers the Coal Dust into the Furnace below it.

in the process of washing gradually settles to the bottom, the water then being used again; and the coal-dust, which can be removed from the tanks after the water has been drawn off, and which is in as finely divided a state as that produced by any crushing medium, can be used for firing boilers. The coal-dust from the settling tanks is used at some Yorkshire collieries—simply hand-fired into the boiler furnace. The plan adopted by the Schwartzkopff Co., which is shown in Fig. 56, is, the fine dust is carried into the boiler from the hopper in a cloud, by the aid of a revolving brush fixed below the hopper, the brush breaking up the dust and delivering it to the boiler in the form mentioned.

The Boiler-feed Problem

In providing power for mining work, the boiler-feed problem is often a very important one, quite apart from the question of whether steam is being generated simply for use in the engines direct, or for use in an electricity generating station. Though a great number of mines have to deal with a large quantity of water in their workings, which has to be pumped to the surface and got rid of in some way, it rarely happens that this water can be used for generating steam. The mere fact that it is pumped out of the mine presupposes that it contains salts, that would have a very serious effect upon the life of the heating surface of the boiler. Water has among its other properties the very important one of dissolving salts of all kinds, from the rocks and earth it flows over or through, and it also has the property of carrying along with it minute particles of the rocks and earth in a state of mechanical suspension. On the other hand, efficient steam generation, that is to say, generation at the lowest possible cost in coal and attendance, requires that the distance between the hot gases passing through the boiler flues or tubes round them, and the water on the other side of the tubes or flues, shall be as small as possible. The most efficient heating arrangement, other things being the same, would be a very thin plate of highly conducting metal, such as copper, with a very thin film of water on one side, and the stream of gases also passing in a very thin layer on the other side. If the water used in a boiler contains salts, these are deposited upon the surface of the tubes, etc., on the water side, and gradually build up a thickness of a substance which offers a considerable resistance to the passage of the heat from the furnace gases through it. Hence it is important that the purest water obtainable should be used. There is also another factor in the problem. When water is being heated in a boiler, the most economical heating will take place if the water is kept continually in circulation, presenting successive new surfaces to the hot plates or

tubes, etc. If water is allowed to remain at rest on a heated surface, minute globules of steam or of heated water form between the surface of the plate and the water beyond, these globules offering a high resistance to the passage of heat through them, and consequently the boiler tubes, etc., reach dangerous temperatures, while the heat does not reach the water in the way that it should do. If, when a proper circulation is created in a boiler, cold water is forced into it at any part, the presence of the cold water instantly checks the circulation, and the result is that the coal consumed is increased. A little consideration will show the importance of this. Take the ideal case given above of a very thin copper plate of very large dimensions, with a very thin stream of water passing over it in one direction, and a very thin stream of hot gases passing under it in the opposite direction; the economy of steam generation under such conditions would be the greatest obtainable. Now imagine some obstruction to be placed in the way of the stream of water on the top of the plate. Imagine a bridge of non-conducting material, so arranged as to break the continuity of the heating surface, to cause the water to break its passage and to go some distance out of its way over the obstruction. The result would be that the water would be partially cooled before it reached the heating surface again, the continuity of the heating surface being broken, a much larger quantity of heat would have to be delivered to the water to enable it to reach the boiling temperature, while the water itself would not have received as large a quantity of heat as it would have done under the ideal conditions sketched. The obstruction sketched is created when water at a much lower temperature than that which is already in the boiler is pumped into it, and it is therefore of importance, quite apart from other economies, that the feed water should be heated as described, by the feed-water heater and the economizer. Further, the importance of heating the feed water is so great that it has been shown to be economical to employ live steam from the boiler itself—steam that has been generated by the expenditure of heat in the boiler, to raise the temperature of the feed water that is to be pumped into the boiler. There are three methods of feeding the boiler—by steam-driven pumps, by electrically driven pumps, and by injectors. The steam pump, as developed by the Worthington Co. and others, is a very economical apparatus. It consists of two cylinders fixed on one bed plate, each cylinder having its own piston, but one piston rod connecting the two; one is the steam cylinder, and the other the water cylinder. As the piston of the steam cylinder moves to and fro it forces the plunger, or whatever the arrangement may be in the water cylinder, to and fro, sucking the water from the supply at one part of the stroke, and forcing it towards the boiler in the other part. In the Worthington pump the apparatus is made in

duplicate. Two pump cylinders and two steam cylinders stand side by side, and they are rendered automatic by a valve rod, which is common to the two pairs of cylinders, and which by a very simple arrangement works the slide valve controlling the entrance of steam to the steam cylinders. The valve rod carries a vibrating arm, which moves a rod connected to the slide valve also, the latter bringing the slide into the position necessary for actuating its piston. The Worthington feed pump has a very simple arrangement of valves in its water cylinder, as shown in Fig. 57. It has a long piston working to and fro, and there are a number of small valves on the suction side closed by springs, and a similar number of small valves on the delivery side also closed by springs. The piston works inside a ring, which divides the water cylinder into two equal portions, the pump being thereby rendered double acting. As the piston recedes from one half the suction valves open, the delivery valve closing, the suction valve in

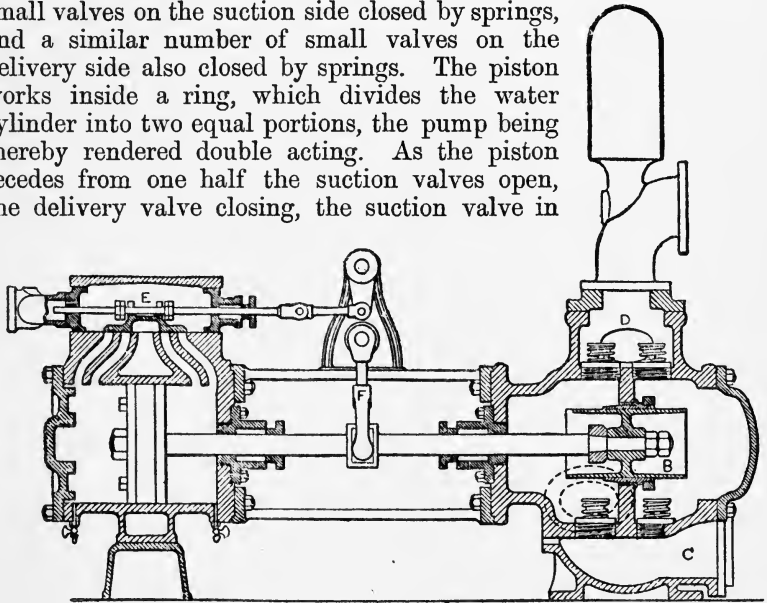

FIG. 57.—Sectional View of Worthington Plunger and Ring Pump. The Steam Cylinder is shown on the Left, the Water Cylinder on the Right, and the Vibrating Arm which works the Steam Admission Valve in the Centre.

the other half closing and the delivery valve opening. As the piston returns to that half, the suction valve in that half closes, and the delivery valve opens, and so on. The Worthington boiler-feed pump may be seen working in almost every kind of works where steam is employed, without any attention whatever, its valve rod and its pistons working to and fro, as explained. It is made in various forms, with two cylinders taking steam at the same pressure, and with four steam cylinders, two being arranged behind the other two, and the steam side working compound. It is also made

for working against pressures up to 300 lbs. per square inch, and it is made in the form of the ram pump, with simple steam or compound steam cylinders. The pumps are also made horizontal or vertical, the horizontal being those most frequently met with.

The electrically driven pump for boiler feed is nearly always the three-throw ram pump. This pump will be explained more fully in Chapter VI. Meanwhile it may be mentioned that there are three pump cylinders, each having a piston attached to a rod, the three piston-rods coming out to three cranks carried on one shaft, and to this shaft an electric motor is geared. The three cranks are spaced 120° apart on the crank shaft, and each ram or plunger, as it rises in its cylinder, opens its suction valve, the water entering the cylinder, and as it is forced downwards the suction valve closes, the delivery valve opens, and the water is forced into the boiler, or wherever it is required. A variation of the three-throw pump is the variable stroke three-throw pump, of which there are two forms, both electrically driven, the object being to vary the quantity of water delivered to the boiler, or elsewhere, without varying the speed at which the motor is running. With the ordinary arrangement of the three-throw pump the stroke is fixed, and the quantity of water pumped depends simply upon the length of the stroke and the number of strokes per minute, multiplied, of course, by the number of pump barrels, so that variation in the quantity of water pumped in a given time can only be obtained by varying the number of strokes per minute, that is, the speed at which the pump is running. Messrs. Mather & Platt exhibited at the Glasgow Exhibition of 1901 a variable stroke pump, in which the three cylinders are arranged in a cylindrical casting around a centre, the pump being driven by an electric motor, and the stroke of the pump being regulated by an arrangement provided for the purpose, so that the quantity of water at each stroke is varied instead of the number of strokes. Messrs. Hayward, Tyler & Co. have also introduced a variable stroke three-throw pump, in which the three pump cylinders are carried in one casting in the usual way, the three pump rods coming up to three eccentrics on the crank shaft instead of to three cranks, and the stroke of the pump is varied by means of the eccentrics. The boiler-feed water may be heated either by making use of a portion of the wasted heat of the gases from the boiler furnace, or by using a portion of the heat remaining in the exhaust steam, or both. In the latest electrical generating stations the feed water passes first through a steam feed water-heater, and then through an economizer.

Injectors

The injector is an apparatus that is making its way more and more. Though it is, strictly speaking, a pump, in that it draws water from the hot well or tank, or wherever the water supply is to come from, and delivers it to the boiler, it operates by the aid of

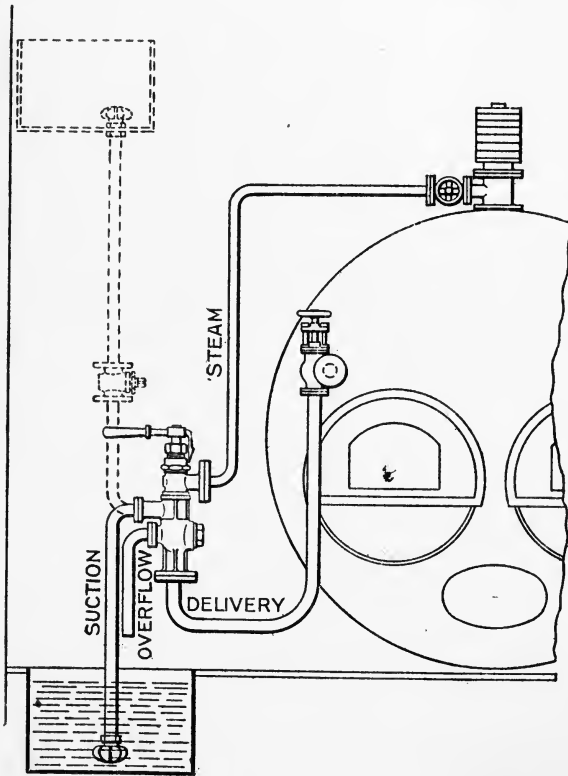

FIG. 58.—Arrangement of Messrs. Holden & Brookes' Injector for feeding a Lancashire Boiler; View in Front of Boiler.

steam alone, and without any moving parts. The apparatus consists of an arrangement, as shown in Fig. 58, in which there is a pipe connected to a supply of steam as from the boiler, ending in a nozzle, arranged so that the steam will enter at a considerable velocity. A pipe, carrying water, enters the chamber into which the steam from the injector delivers, and the steam, passing onwards through the



PLATE 3A.—A Battery of Green's Economizer Tubes in Process of being Fixed at Pendlebury Collieries. The Tubes will be built in, the Flue shown being connected to the Chamber.

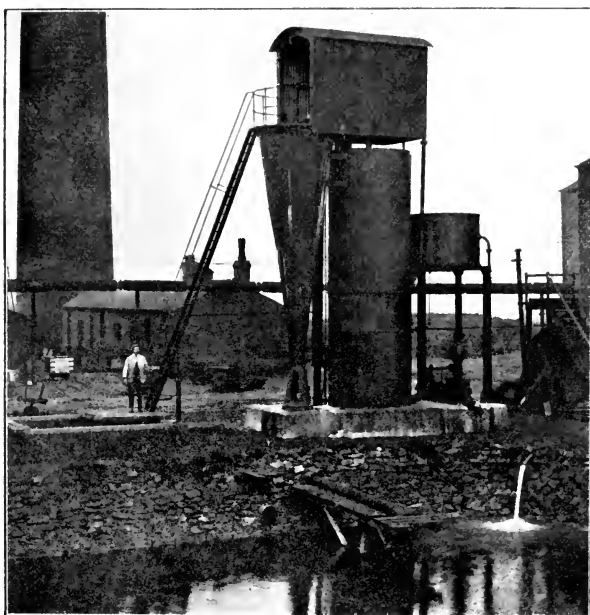

PLATE 3B.—Messrs. Royles' Water Softening Plant, fixed at Dalborne Collieries, Lancashire.

[To face p. 112.]

passages of the apparatus into the boiler, draws the water after it, carrying it with it into the boiler. The injector may be used with exhaust steam, though care must be taken that the oil which comes over from the engine cylinder with the exhaust steam, is eliminated from the steam before it enters the injector, or the oil will be passed into the boiler with the steam. When the injector is used, the feed-water heater is sometimes displaced, since the steam heats the water it carries with it to a certain temperature. It is claimed that an

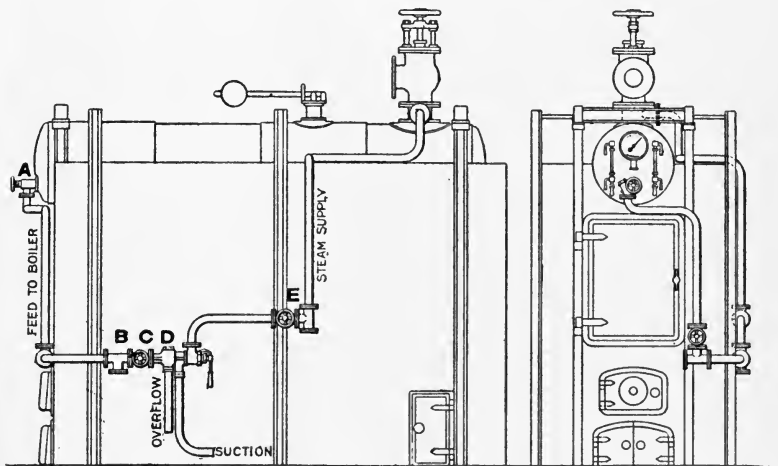

FIG. 59.—Arrangement of Messrs. Holden & Brooke's Injector for feeding a Babcock & Wilcox Boiler.

injector, working with exhaust steam, will feed a boiler against a pressure of 75 lbs. per square inch with feed water at about 65° Fahr., while with live steam the feed water may be injected into the boiler against a pressure of 200 lbs. per square inch, by properly proportioning the pressure of the steam in the injector, the feed water in that case reaching a temperature of 250° Fahr. Figs. 58 and 59 show the connections of Messrs. Holden and Brooke's injector for feeding Lancashire and water-tube boilers respectively.

Economizers

The Economizer has been so named by the firms who have introduced it because it is claimed to economize coal, though it is only one of a number of apparatus designed for the same purpose. It consists of a number of iron tubes fixed vertically inside a brick

chamber, through which the hot gases from the boiler are led on their way to the chimney, and the feed water for the boiler is forced through these tubes on its way to the boiler. A portion of the heat contained in the gases is extracted from them as they pass through the economizer, the heat being delivered to the feed water. The hot gases which pass around the economizer tubes deposit carbon in the form of soot on the outside of the tubes, and unless this is continually removed, there is the same building-up of resistance to the passage of heat to the water inside the tubes, as with the scale on the inside of the boiler. The makers of economizers have grappled with the problem, and all apparatus of the kind are fitted with scrapers, arranged to clasp the outsides of the tubes, and to be kept continually in motion, removing the deposit of soot, the soot being allowed to fall into a pit below, and removed when convenient. The scrapers are worked from above by a mechanical arrangement devised for the purpose, consisting of a long girder supported at each end, and carrying pulleys, over which chains pass, the chains having scrapers at each end. The chains are kept moving up and down, pulling the scrapers up and down, by any convenient source of power, such as a small engine, and more frequently, when electricity is generated on the ground, by an electric motor. There are a number of forms of economizers, the differences between them being in the forms of the tubes, and in the arrangement of the scrapers and methods of driving them. In all forms it is endeavoured to arrange that a thin stream of water shall be passing in the tubes at a comparatively high velocity, separated only by a small thickness of metal from the hot gases. Plate 2D shows Carter's economizer, and Plate 3A a battery of Green's being fixed at a colliery.

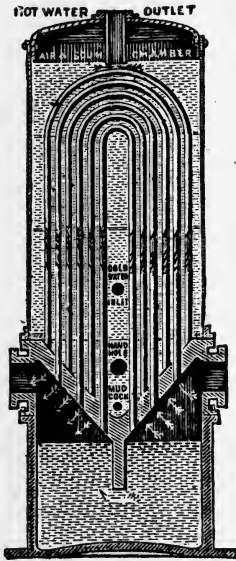

FIG. 60.—One Arrangement of Feed-water Heater. The Steam passes through the Pipes, the Water in the Space surrounding them.

Feed-water Heaters

The feed-water heater consists of a closed vessel filled with tubes, and the arrangements are different in apparatus by different makers. In some forms the steam passes through the tubes, and the water in the space surrounding them. In other forms the water passes through the tubes, and the steam

in the space surrounding them. In either case the steam is made

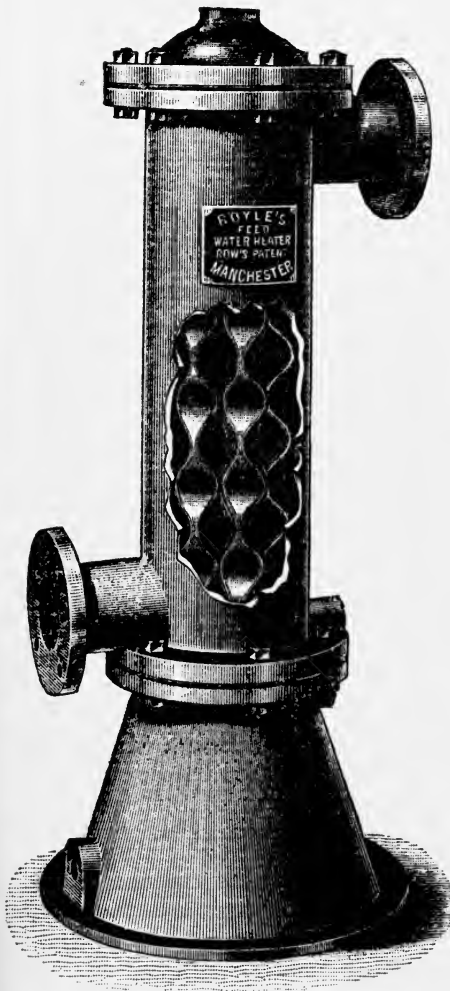

FIG. 61.—Royle's Feed-water Heater.

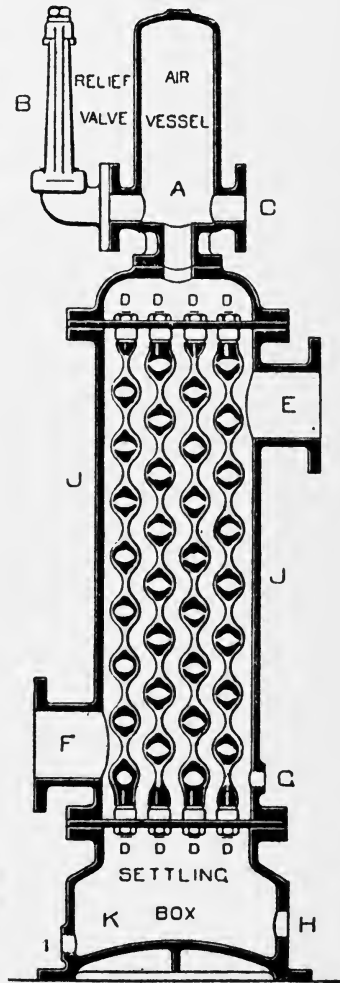

FIG. 62.—Vertical Transverse Section of Messrs. Royle's Feed-water Heater, showing the specially formed Tubes employed.

to deliver as much as possible of its heat to the water. Figs. 60, 61, 62 show two forms of feed-water heaters.

Water Softeners

Another important source of economy in connection with boiler work, in a great many cases, is the water softener. The only water available for raising steam very often contains salts of lime and magnesia, and other substances. The salts commonly present are the carbonates of lime and magnesia, which give rise to what is called temporary hardness. The sulphates of lime and magnesia, and other elements, are also sometimes present, giving rise to what is called permanent hardness. The peculiarity of the carbonates is that they are usually present in water as bicarbonates, that is, with two portions of carbonic acid in combination with the metal. The bicarbonates are soluble in water at ordinary temperatures, but the carbonates are insoluble. Hence, when the feed water contains bicarbonates, they pass into the boiler, dissolved in the water; but when the water is heated, one portion of carbonic acid is driven off, the carbonate is precipitated upon the surface of the boiler on the water side, and a scale is gradually built up which has a considerable thermal resistance, besides reducing the available water space. The sulphates which form the permanent hardness are not driven off by heat, but they are also deposited upon the water surface of the boiler, largely owing to electrolytic action, and the same result follows. The efficiency of a boiler may be very considerably reduced by the presence of a certain thickness of scale. All the water softeners on the market are on certain general lines. In nearly all of them heat is applied to the feed water before it is allowed to enter the boiler, for the purpose of driving off the carbonic acid, thereby producing the insoluble carbonates, and these are precipitated by the addition of a certain quantity of lime. The permanently hard salts are also deposited by the addition of lime and soda. In addition to the above arrangements, nearly all the water softeners include filters, which extract the insoluble substances that have been produced by the action of the chemical reagents. The makers of water-softening apparatus have turned their attention principally to making their processes automatic, and their apparatus contain various devices by which a certain quantity of the reagents are added to a certain quantity of water periodically, a rather favourite form being a tumbling arrangement, which, when filled with water, receives a definite charge of chemicals, and then empties itself into the next portion of the apparatus. Plate 3B shows Royle's water softener fixed at a colliery.

Grease Extractors

Another apparatus, also tending to economy in the same way as does the water softener, and sometimes in combination with it, is the grease extractor, or the oil separator, as it is frequently called. It is necessary to use oil in the steam cylinder for lubricating the piston, and at every stroke a certain small quantity of the oil is carried over

into the exhaust in a finely divided state, and a portion of it is frequently deposited upon the condenser tubes, where surface condensers are employed, but some of it finds its way back into the boiler, and is one of the most frequent causes of the formation of scale. There are almost innumerable oil separators on the market, all of them working very much on the same lines. The steam in its passage to the condenser is passed through a vessel in which it is given a whirling motion, and in which there are a number of baffles, the object being to stop the passage of the minute globules of oil, while the steam passes on its way, the oil draining afterwards to the bottom of the vessel, and being removed by a pump, and used over and over again after filtration. The objection to this method of extracting the oil is that the pump which removes the oil, can only do so by creating a higher vacuum in the oil separator, than the air pump is producing in the condenser. On

the other hand, it is a distinct advantage to remove the oil from the steam before it passes into the condenser, because the efficiency of the condenser will be distinctly reduced by the deposit of oil upon its pipes, and this is a not infrequent source of trouble with surface condensers. If the oil is not removed before the steam passes into the condenser, an oil filter is interposed in the path of the feed water before it enters the boiler. The oil can be used over again, if filtered. Fig. 63 shows one of Wells' apparatus designed for the purpose.

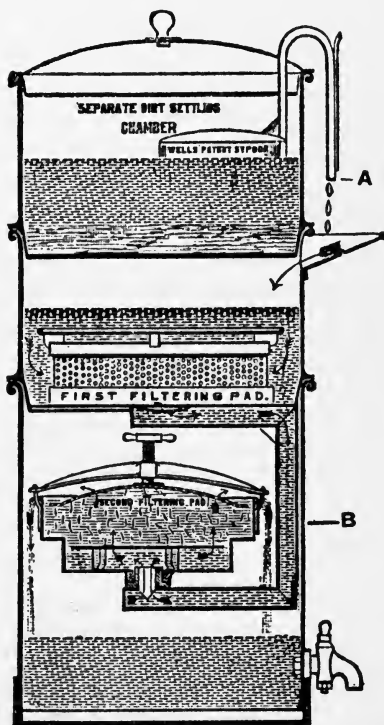

FIG. 63.—One Form of Wells' Filtering Apparatus for Waste Oil.

Coal Conveyers

Another apparatus which contributes to economy, where the station is of sufficient size to warrant its adoption, is the coal-handling plant. In large stations, which are arranged, if possible, on the bank of a river, or on a railway siding, and to which the coal is brought either in barges or in trucks, there is now a complete apparatus for unloading the barges and trucks, carrying the coal to coal bunkers, which are usually placed at the top of the building, weighing it on its way to the bunkers, and carrying it from the bunkers to the hoppers over the boiler furnaces. The first arrangement consists of a crane, to which is attached what is called a "grab." The grab is practically a coal box split into two halves, each half being hinged separately, and held from the end of the chain worked by the crane. When the weight of the grab and the coal it contains is on the chain, the two halves of the grab close up together, forming practically a box with the cover in two halves held loosely together. When the grab is lowered into the barge or truck, it opens, the two halves separating out, and sinking by their weight into the mass of coal, which usually has a large proportion of small, in a modern power station; and when tension is put on the chain, the two halves move towards each other, enclosing the coal they have grabbed. The whole thing is run up to the head of the crane, swung round over usually a large receiver or hopper, to which a weighing machine is attached. Thence the coal passes by a bucket conveyer to the top of the building, where it is delivered to a band conveyer, which carries it to its temporary destination. The bucket conveyer consists of an endless chain fixed at an angle with the vertical, depending upon the position to which it is required to carry the substance being handled, and having attached to its links, buckets or scoops, which pass round, and over rollers at the top and bottom. The bottom of the conveyer is so arranged that the bucket which is emerging from the off-side, scoops a bucketful out of the coalying in a mass ready for it. The bucketful is carried to the top of the conveyer, and is there tipped over on to the next apparatus that is to receive it. The band conveyer is simply a wide belt running on rollers, the coal being tipped on to it in such a manner that it spreads out along the belt in a thin stream, and is carried by it to the bunker that is being filled. At the bunker the belt is suddenly given a sharp turn by means of special pulleys, interposed in its path, and the coal is shot forward into its place. Another form of conveyer that is often used where very fine coal is employed is the "archimedean" screw. The archimedean screw or traveller is a screw with a very wide blade and a very coarse pitch. It runs in a trough, which may be open at the

top, the coal or other substance to be conveyed being delivered to the trough at one end. The blade of the screw engages with a small portion of the coal as the screw revolves, and it carries that portion forward in its revolution, each turn of the screw engaging with some coal, the coal remaining at the bottom of the trough, but being continually moved forward, and is delivered to whatever is to receive it at the other end, the last turn of the screw pushing it out. Conveyers are also employed for delivering the coal to the hoppers over the furnaces, the conveyer being loaded at one end or at any convenient portion from the bunker overhead, the coal usually passing through a weighing machine on its way to the boiler furnace. The same conveyer, or another specially arranged for the purpose, is sometimes used for carrying the ashes away from the ashpit, and delivering them either on to small trucks arranged to receive them at the end of the boiler range, or to any convenient receptacle.

Steam, generated in any of the boilers described, may be used in either reciprocating engines, or turbines, to drive electric generators.

Reciprocating Steam Engines

Reciprocating steam engines are broadly divided into two groups, known respectively as "high-speed" and "low-speed" engines. The terms are really very misleading, as the piston speed, which is the determining factor in any engine, is the same in the so-called slow-speed engines as in the high-speed engines. In addition to this, also, in the so-called slow-speed engines there are larger and heavier masses of metal in motion than in the high-speed engines, and it is perhaps not surprising that the so-called high-speed engine is gradually displacing the so-called low-speed engine for a great deal of the new work that is being put down. The terms "quick-revolving" and "slow-revolving" were substituted a short while since for the terms "high-speed" and "low-speed," and those terms very much more accurately express what actually takes place. The so-called high-speed engine runs at 300 and 400 revolutions per minute, while the so-called slow-speed engine runs at anywhere from 50 up to 150 revolutions per minute. Not many years ago the limit was from 20 to 100 revolutions for slow speeds. The same power is obtained from a large piston with a long stroke, and making only a few revolutions per minute, as from a smaller piston with a shorter stroke making a larger number of revolutions per minute. The high-speed engine was for a long time looked at with considerable doubt by practical engineers. They feared that the engine would knock itself to pieces, and a great many of the earlier high-speed engines did so. On the other hand, the large slowly revolving low-speed engines rarely gave any trouble, and were,

and are still, very economical in steam, when worked with Corliss valves, and with the other modern apparatus that has been brought into service for increasing the steam economy. The advance in the construction of high-speed engines is very largely due to the researches of the late Mr. Willans, of the firm of Willans & Robinson. It may almost be said that the Willans engine was the first quickly-revolving engine that achieved practical success. But the Willans engine overcame the difficulties of lubrication, which were the great stumbling-block to the early inventors of high-speed engines, by a new departure, and by practically sacrificing half the work the engine can be made to perform. In the Willans engine steam is only taken on one side of the piston, and the crankshaft revolves in a bath of oil and water, the whole apparatus being enclosed and the valves being carried in the piston rod itself. The arrangement makes a very compact engine, especially where, as is usually arranged with compound and occasionally with triple-expansion Willans engines, the high-pressure, intermediate, and low-pressure cylinders are fixed vertically one above the other, one piston rod carrying the whole of the pistons, and, of course, the whole of the steam valves. Forced lubrication, as applied in the Belliss and other engines, under which arrangement a constant supply of oil is forced into the bearings of all the moving parts of the engine, enabled the high-speed engine to be worked with steam entering on both sides of the piston, and it is now claimed that the Belliss and similar engines are more economical in steam, and quite as reliable as the Willans engine.

There is little to be said about the slowly-revolving engines, except that the substitution of the Corliss valves for the old pattern slide valves has enormously increased their economy in steam. The Corliss valve consists of a cylinder of metal, in which the valve ports are cast, which revolves inside a cylindrical space in the engine casting, in which are other ports, the motion of the crankshaft bringing the different ports opposite each other, for the purpose of the admission of steam to the engine cylinder, the reverse motion cutting it off in the same manner as the motion of the slide valve along the face of the cylinder, performs the same operations.

Working Steam Engines expansively

Steam engines are classed under the headings, simple engines, compound engines, triple and quadruple expansion engines. In the simple engine there is one cylinder, and the steam enters behind the piston, pushes it to the end of the stroke, and passes out to the atmosphere or to the condenser. The simple engine may consist of two cylinders coupled together, with a flywheel or similar arrangement

between them, each cylinder taking steam at the full boiler or throttle valve pressure, and the steam passing from each cylinder to the atmosphere or to the condenser independently. In the compound engine there are two cylinders, one of which has a larger piston than the other. The cylinders are termed "high" and low "pressure," and the steam enters the high-pressure cylinder, passes from the exhaust of the high-pressure cylinder usually to a receiver, thence to the low-pressure cylinder, and thence to the atmosphere or the condenser. There is a special form of compound engine made by Messrs. Belliss & Morcom, and others, in which, the two cylinders being placed so that their cranks are 180° apart, no receiver is necessary, since the low-pressure cylinder will be taking steam at the same time as the high-pressure cylinder is exhausting. In the triple-expansion engine there are three cylinders, sometimes four, named respectively the high-pressure or H.P., the intermediate or I.P., and the low-pressure or L.P. Where there are four cylinders, the low-pressure cylinder is divided into two, and the object is to obtain a more even turning moment on the crankshaft and a better distribution of the steam. The steam passes first into the high-pressure cylinder, thence to a receiver, thence to the intermediate cylinder, thence to a receiver, thence to the low-pressure cylinder or cylinders, and from there to the atmosphere or condenser. In the quadruple-expansion engine there are four, and sometimes five, cylinders. Where there are five cylinders, the low-pressure cylinder is again divided into two, and the steam passes in succession through the high-pressure, the first intermediate, the second intermediate, and the low-pressure, thence to the atmosphere or condenser. Quadruple-expansion engines are not often seen on shore, but they are employed largely in some of the big ocean liners. Triple-expansion engines, however, are becoming more and more common as they are better understood and their manufacture is improved. The great object of the additional cylinders is the economical use of the higher steam pressures that are employed in modern steam plant. The major portion of the heat employed in the generation of steam is taken up in converting the water at a certain temperature, into steam at the same temperature. With steam at atmospheric pressure and at 212° temperature, 966 units are absorbed per pound by the latent heat of the steam. The specific heat of steam being only 0.4, it is easily understood that the heat given to the steam after its generation is very much more usefully employed than that given to the water to convert it into steam; but this is only on the condition that the whole, or a large portion of the energy in the steam, can be employed in the engines. A great deal of economy in steam consumption is now attained, even in simple engines, by only admitting steam to the cylinder during a small portion of the stroke. In the earlier forms of reciprocating

engines, and even in some forms of engines to be seen at the present day, the work done by the steam upon the piston is in the nature of a continuous push. Where the steam is admitted behind the piston for the whole of the stroke, and where the boiler is generating steam as fast as it is used by the engine, the steam simply pushes the piston to the end of the stroke, the push being taken right from the boiler. But this method is exceedingly wasteful in steam, and there are records of small steam engines, steam pumps, and other apparatus using as much as 250 lbs. of steam per indicated horse-power, where the latest type of reciprocating engine working expansively only uses 12 lbs., or thereabouts. Some thirty or more years ago the first steps in the direction of the economical use of steam were taken by setting the slide valves in the majority of engines to cut off at half stroke; that is to say, when the piston had travelled half its way through the cylinder, the entry of steam behind it was stopped, and the remainder of the passage of the piston was obtained by the expansion of the steam already in the cylinder, the pressure of the steam gradually falling as the piston moved forward. It was evident that this method could be extended, and in some types of simple engines the steam is cut off as early as one-tenth of the stroke, the remainder of the work being done by the expansion of the steam itself, and it is claimed, and apparently with justice, that these engines would, combined with condensers, work with fair economy. In the compound, triple, and quadruple expansion engines, the steam is made to work expansively in each cylinder as well as by passing through the cylinders in succession; that is to say, the entrance of the steam is cut off at a certain portion of the stroke in each cylinder, and in each cylinder the remainder of the work upon the piston is performed by the expansion of the steam. It will be understood that while the expansive working of the steam in a single cylinder, and in each of the cylinders of compound and triple expansion engines, leads to economy of steam consumption, and therefore of coal, it also means that a smaller amount of work is performed by each individual cylinder. Perhaps a few figures will illustrate the point more clearly. While the steam is entering the cylinder behind the piston its pressure is the same as that of the steam chest, less any pressure that it may be deprived of by the action of the governor. After the entry valve is closed, the pressure behind the piston is continually falling until the end of the stroke, and the pressure that must be employed for calculation of the actual indicated horse power generated by the piston, is the mean of all the successive pressures, from the moment the steam commences to enter the cylinder. Taking what is now very common, 150 lbs. initial pressure, absolute, at the boiler, or approximately 135 lbs. gauge pressure; with the steam cut off at three-quarter stroke, the mean pressure behind the piston is

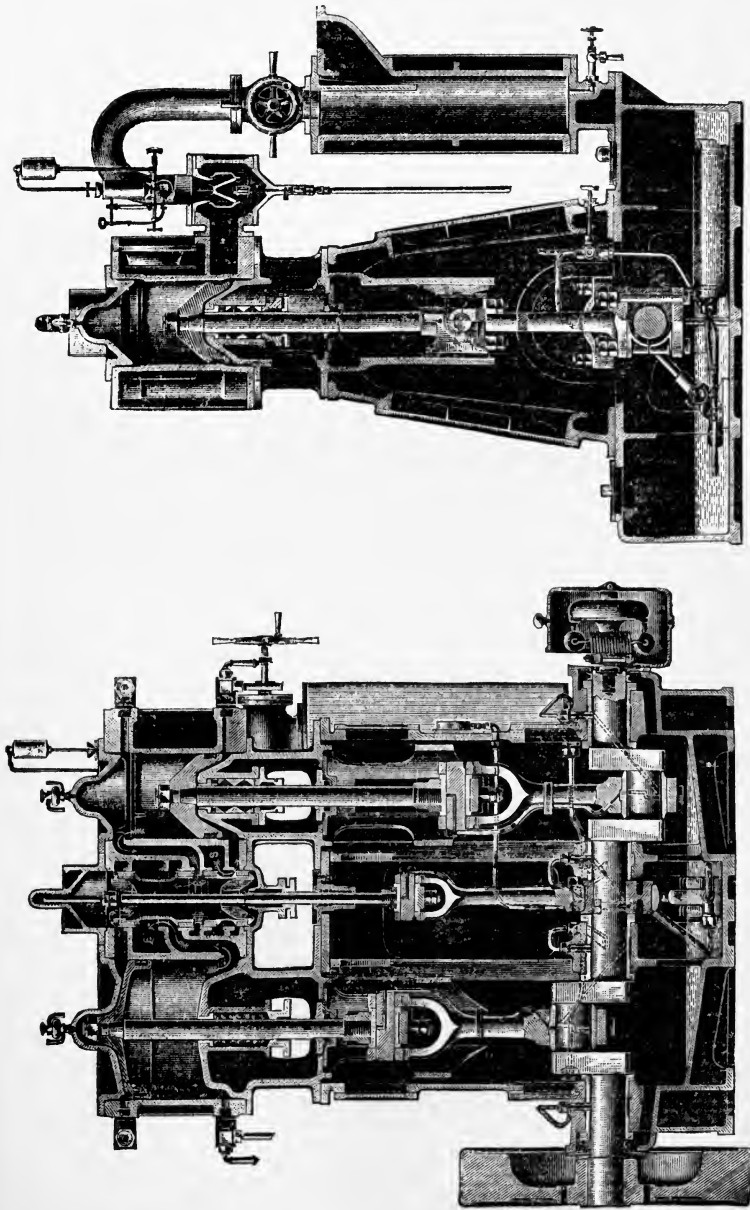

FIG. 64.—Sections of Compound Belliss' Engine. The Low Pressure Cylinder is on the Left.

144·8 lbs. per square inch ; with steam cut off at half-stroke the mean pressure is 126·9 lbs. ; with steam cut off at quarter-stroke it is reduced to 83·5 lbs. ; at one-sixth stroke to 69·8 lbs. ; and at one-tenth-stroke it is 49·5 lbs. That is to say, with a cut-off at one-tenth of the stroke, the mean pressure operating to drive the piston forward in any particular cylinder, with an initial gauge pressure of 135 lbs. per square inch, is a little over one-third of that when the steam is allowed to pass into the cylinder for three-quarters of the stroke, or the engine would only perform a little less than one-third the work at one-tenth cut-off that it would at three-quarters cut-off. In addition to this, the mean effective pressure, the actual force available for driving the piston forward, is the mean pressure behind the piston, as explained above, less the mean pressure of the steam which is in front of the piston, the steam which remains in the cylinder after the piston has completed its stroke in one direction, and which the piston has to drive out of the cylinder on the return stroke.

With compound, triple, and quadruple expansion engines it is always arranged, as will easily be understood, that the work done on the piston of each cylinder, or pair of cylinders, is equal ; that is to say, the work done in the single high-pressure cylinder in turning the crankshaft is equal to that done in the low-pressure cylinders. Where the low-pressure cylinder is divided into two, the combined work of the two cylinders is equal to that in the intermediate cylinder and to that in the high-pressure cylinder. This leads, it will be seen, to the cylinders themselves having different areas, the high-pressure being, of course, the smaller, and the sizes increasing as the steam pressure decreases. Further, in the matter of the government of the engine, it should be arranged that the mean effective pressure in each cylinder is such that the total work in horse-power in each cylinder, that is to say, the product of the mean effective steam pressure, multiplied by the area of the piston, is the same for H.P., I.P., and L.P. There are two methods of arranging the government of compound or triple-expansion engines. In one method the governor controls the cut-off in each cylinder in such a manner that the horse-power in each is practically the same ; in the other method the cut-off of the low-pressure cylinder is fixed, the governor merely controlling the cut-off in the high-pressure and intermediate. Figs. 64 and 65 show sections of Belliss' compound and triple expansion engines. Plate 4A shows a Belliss' triple expansion engine coupled to a three-phase generator.

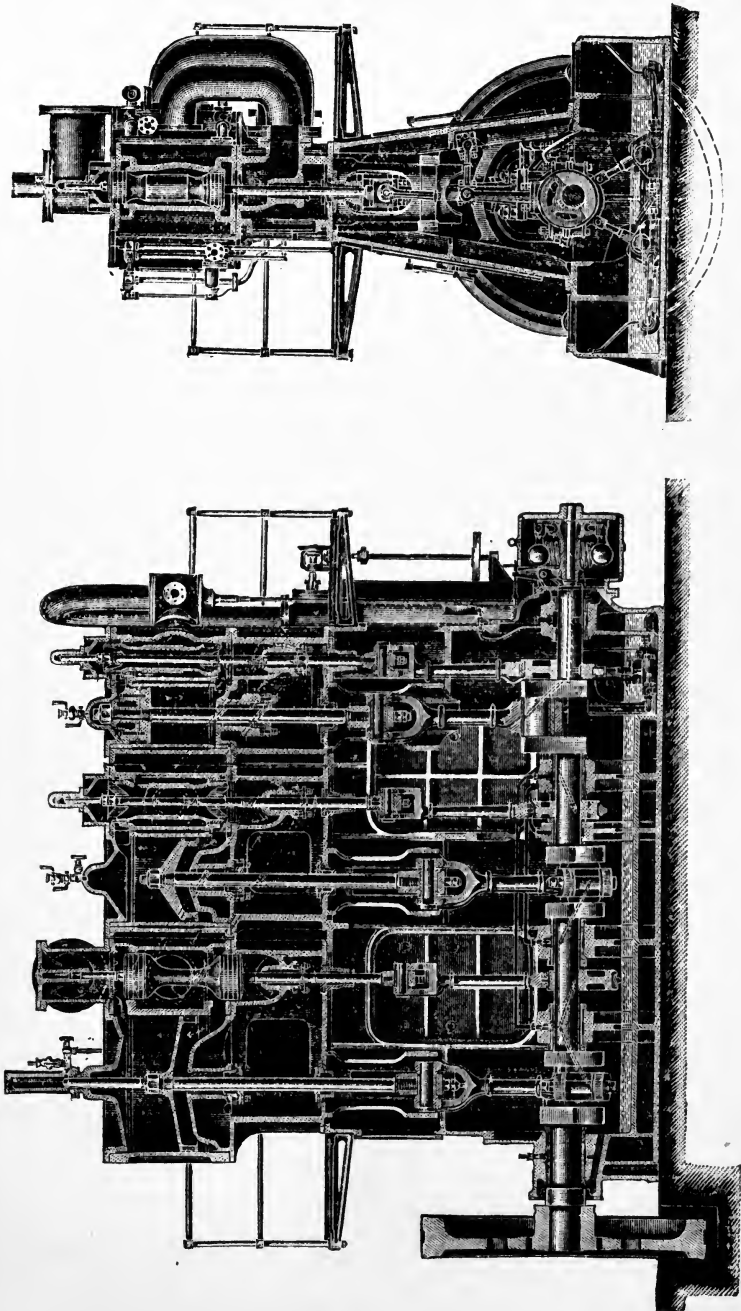

FIG. 65.—Sections of Triple Expansion Belliss Engine.

The Government of Steam Engines

There are two methods of governing steam engines, known respectively as throttle governing, and expansion governing. The object of the governor in both cases is to proportion the consumption of steam to the work the engine is performing, cutting off the supply if the load decreases, and *vice versá*. Both methods operate by means of the well-known centrifugal governor with revolving balls, these acting either upon the entry valve to the steam chest, or on the entry valve to the cylinder itself. The throttle governor acts upon the entry valve to the steam chest, and is practically the equivalent of a stop valve operated by hand by a careful attendant, who is instantly posted as to changes of load. It operates by the variation in the speed of the crankshaft of the engine produced by a change of load. When the engine is running, the governor balls fly out in opposition to a spring or weight, sometimes to a combination of the two. When the engine is running at its proper speed with any load, the valve assumes a position which allows sufficient steam to enter to perform the work in front of the engine. If the load increases, the engine slightly slows down. The reduction of speed of the crankshaft is followed by a reduction of the speed of the governor balls, the governor being driven by a strap or gearing from the crankshaft, and occasionally fixed on the end of the crankshaft. The governor balls lose a portion of their centrifugal force, move slightly towards the centre, the spring or weight opposing them then slightly opens the valve, an increased quantity of steam enters, and the engine recovers its normal speed. The expansion governor operates in exactly the same manner, but in place of acting upon the stop valve or its equivalent, it acts directly upon the slide or other valve controlling the entry of steam to the cylinder, altering the period during which the valve is open. Thus, if the engine receives an increased load, the expansion governor increases the proportion of the stroke before the steam is cut off, this, of course, increasing the mean pressure behind the piston and the available power. The expansion governor is now almost universal, though the throttle governor is still occasionally to be seen, and some engineers prefer it.

Difficulties in the Way of working expansively

While expansive working of steam brings very considerable economies, and has enabled the quantity of coal consumed per indicated H.P. to be reduced from the neighbourhood of 10 lbs. to $1\frac{1}{4}$ lbs., the usual crop of difficulties has arisen in its path, the first,

and perhaps the most important, being the trouble with the condensation of steam in the cylinders. When steam is generated in a boiler, there is a mechanical action going on at the same time as the conversion of water into steam is taking place, minute globules of water being carried over with the steam from the boiler into the steam pipes, steam chests, etc. These minute globules are of the nature of the vapour that we are familiar with in the case of fogs and mists. They are not steam. They are possessed of a certain quantity of heat, but not sufficient to enable them to maintain the condition of misty globules, in the face of a lowered temperature in their surroundings. They meet this lowered temperature on entering the cylinder of an engine that is working very expansively. Taking the case given above of steam at an absolute pressure of 150 lbs. per square inch, and assuming, for simplicity, that the steam is at that pressure on entering the cylinder, its temperature is 358° Fahr. Assuming that the steam is cut off at a very early part of the stroke, and that it is expanded down to a few pounds above atmospheric pressure, its temperature at the end of the stroke will be in the neighbourhood of 225° to 230° Fahr.; that is to say, there will be a difference approximately of 130° Fahr. between the temperature of the steam on its entrance to the cylinder and on its exit. The cylinder walls, the piston, etc., follow these changes of temperature to a certain extent, with the result that at the end of the stroke, and at the commencement of the succeeding stroke, the temperature of the cylinder space into which the live steam enters may be a great many degrees below that of the entering steam. The first result of this is the condensation upon the cylinder walls, piston, etc., of the vapour of minute water globules that have come over from the boiler with the steam, and this deposited water is re-evaporated at a later period of the stroke by the absorption of heat from the cylinder walls, etc., the result being that the steam itself is possessed of a smaller quantity of energy, and the mean pressure available for driving the piston is smaller than would be the case if the cylinder walls had remained at the same temperature as the entering steam. The above case has been taken by the writer as an illustration because it shows the matter so clearly; but the case of the simple engine working with a very high ratio of expansion is rather exceptional, and the above is one of the reasons that have led to the development of the compound, triple, and quadruple expansion engines. In the cylinders of compound, triple, and quadruple expansion engines, however, the same phenomena occur, though to a smaller degree, because the range through which the steam pressure and the steam temperature pass, is divided up between the successive cylinders, and the changes of temperature in each cylinder are not as great as where the whole of the expansion takes place in one cylinder.

Overcoming Condensation Troubles

There are two principal methods employed for overcoming the troubles and the waste due to the condensation of steam in the engine cylinders, viz. by jacketing the steam cylinders, and by superheating the steam. In the first method a jacket, similar to that fitted to gas engines, is fitted to the engine cylinders, and the steam is made to pass through this jacket on its way to the entry valve. In some cases the steam jacket has been applied to all the cylinders of compound and triple expansion engines, and it has also been applied as a reheater to the receivers between the different cylinders. The economy of the steam jacket would appear to depend very much upon the number of expansions, as it is usually expressed; that is to say, upon the period at which the entry of steam is cut off. If the steam is cut off early, so that there is a wide difference of temperature between the steam entering at the commencement of the stroke and that leaving the cylinder on the return stroke, steam jacketing should be of service, and it is stated that economies of as much as 25 per cent. have been obtained when the steam was expanded 6 times in an individual cylinder, and 15 per cent. when it was only expanded $2\frac{1}{2}$ times. Some experiments have been made from time to time on the economy of reheating the steam between the cylinders, and this also appears to be considerable under certain conditions. The steam jacket operates by maintaining the temperature of the cylinder more nearly uniform throughout the stroke, than it can be when the cylinder walls are subjected only to the varying temperature of the steam on the inside, and the atmospheric temperature outside. In the case of reheating the steam in the receivers between the cylinders, the object to be attained is the conversion of any water that may be formed by condensation, into steam before the steam passes on to the next cylinder, and with it the reduction of condensation in that cylinder. With many engineers, however, steam jacketing has not found favour. As in so many other cases, very much depends upon how the steam jacket is fitted and how it is worked. In the case of some compound engines which came under the writer's notice, very large jackets were fitted, and the engineer complained that while the warming effect on the cylinders was comparatively small, the waste of steam by condensation in the jacket was large. In other cases the steam jackets have been too small, and the warming effect on the cylinder walls has not been worth the loss of steam pressure due to the passage of the steam through the jacket. Whether the steam jacket is economical or not depends upon the thermal insulation of the steam cylinder outside the jacket. And this brings us to another matter which is too often

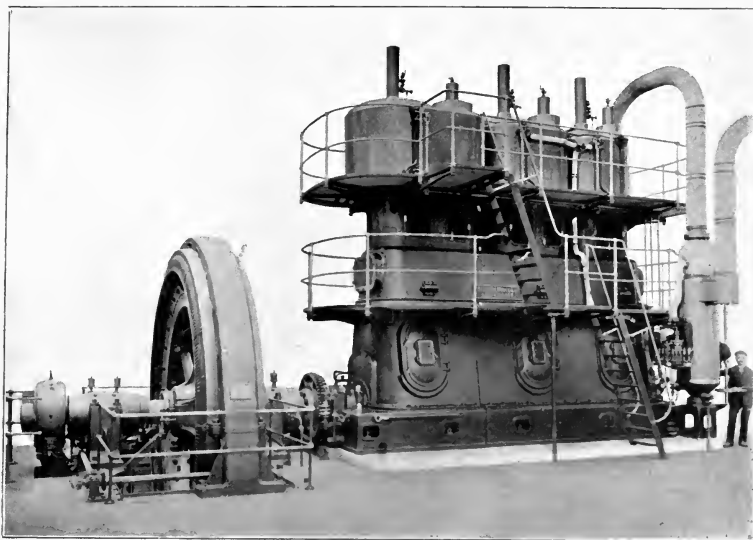

PLATE 4A.—Belliss' Triple Expansion Engine, directly connected to a Three Phase Generator.

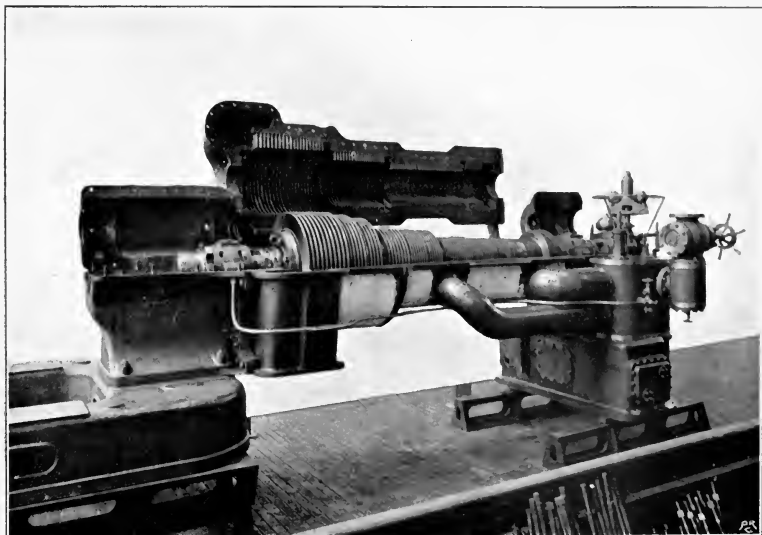

PLATE 4B.—Parson's Steam Turbine, as made by Messrs. Willans & Robinson, with the Turbine Case open for Inspection. The Governor is seen on the Right.

[To face p. 182.]

neglected by steam engineers—the thermal insulation of the cylinders, valves, etc. Every engineer is familiar with the warm atmosphere that nearly always pervades a steam engine-house, in marked contrast to that pervading a machine house of any kind where the driving is by electric motors. The engine cylinders and the steam pipes are sometimes allowed to radiate vigorously into the surrounding atmosphere, wasting heat, tending to greater cylinder or jacket condensation, and creating the atmosphere of the room and the draughts that are often so trying. Proper insulation of the engine cylinder, steam pipes, valves, etc., would add very considerably to the economy of the plant, and the comfort of those working in it. Steam engineers appear to be always alive to the importance of insulating their boilers, where the boiler shell is exposed to the atmosphere, and their steam pipes, though this is not always done; but there are still some who have not yet appreciated the importance of insulating the engines themselves.

Superheating

By superheating is understood the delivery of heat to the steam after it has left the steam space of the boiler. In the steam drum of the water-tube boiler, and in the steam space in Lancashire boilers, the steam is in direct contact with the water, and is continually receiving additions of watery vapour, rising from the water with which it is in contact, particularly when rapid steaming is taking place. In all superheating apparatus the steam, after it has left the steam space of the boiler, is made to pass through a number of pipes, usually of smaller diameter, on its way to the main steam pipe supplying the engines. The small pipes are subjected either to the heat of the gases from the boiler furnace itself, or to heat generated in a special furnace arranged for the purpose. In several of the water-tube boilers the superheater consists of coils of pipe, suspended in the space inside the outer brick setting, near the exit of the gases to the chimney or economizer. When a separate furnace is employed, the arrangement is very similar to that of an ordinary boiler furnace, but in place of the usual boiler tubes, the superheating tubes are fixed so as to obtain the full benefit of the heat from the gases produced in the furnace. The primary object of superheating the steam is the elimination of the watery vapour that has been mentioned, and that so promptly condenses when the temperature is lowered. It is claimed by the advocates of superheating that the steam itself receives no heat until the whole of the water which it carries in suspension has been converted into steam, and the idea has arisen among some steam engineers that steam which has been

passed through a superheater must necessarily be dry. In the writer's opinion this is not strictly correct. The specific heat of

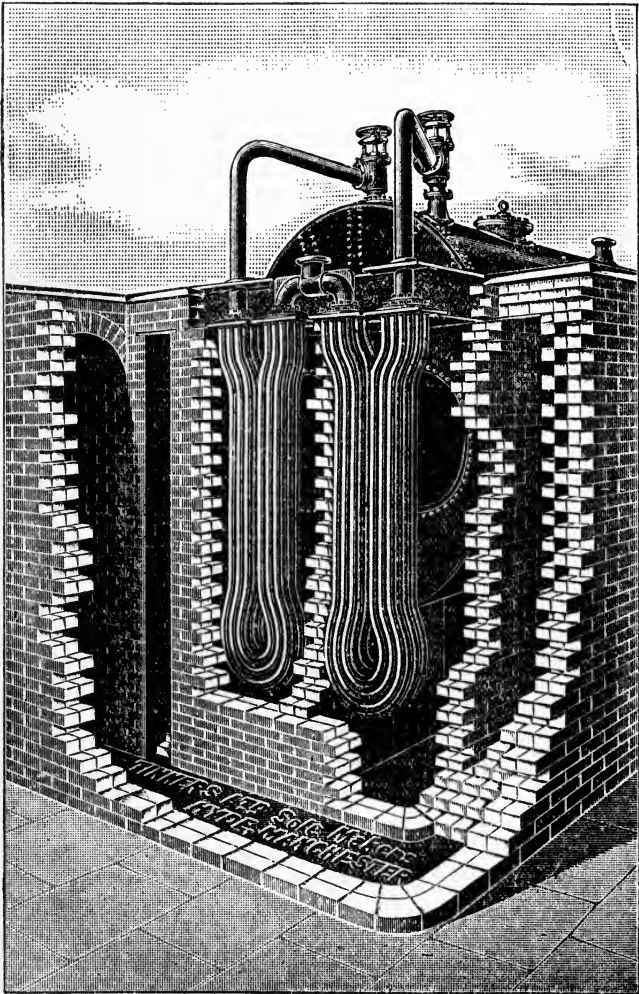

FIG. 66.—Tinker's Superheater, as fitted to a Lancashire Boiler. The Steam to be heated passes through the Coils of Pipes shown, the Pipes being fixed in the Path of the Hot Gases from the Boiler Flues to the Chimney.

water being 1·0, while that of steam is 0·4, any water that is present will absorb a larger quantity of heat in proportion to its weight than

the steam which surrounds it; but in the writer's view it would be contrary to all the laws governing the transmission of heat if the steam also did not receive a certain quantity of heat, proportional to the difference of temperature between itself and the pipes in which it is passing, and to its own specific heat. It is evident that if a certain quantity of vapour is present with the steam, sufficient heat must be delivered to each pound of steam and water vapour passing through the superheater to convert the whole of the water vapour into steam, and in addition to this an allowance must be made for heat delivered to the steam itself. The result

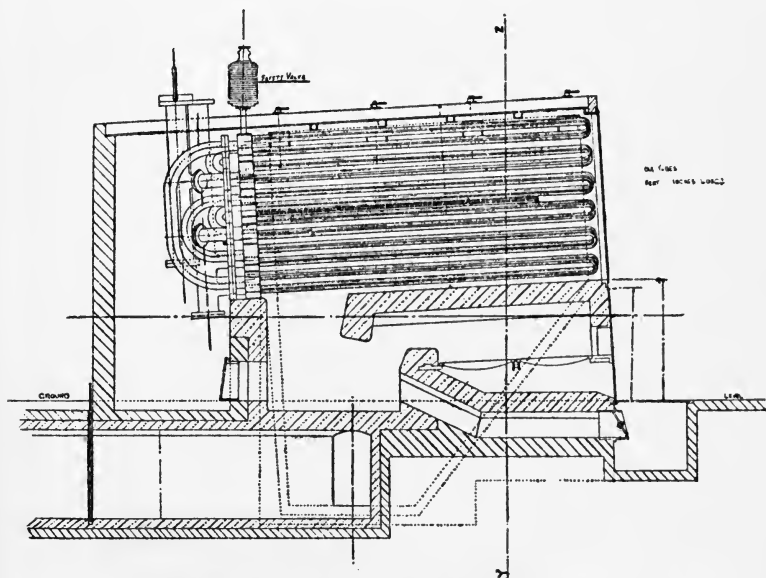

FIG. 67.—Longitudinal Section of Messrs. Davey, Paxman, & Co.'s Separately Fired Steam Superheater. The Steam passes through the Coils of Pipe shown, the Hot Gases passing up and all round them.

of superheating the steam is distinctly satisfactory, and apparently within certain well-known limits, it is perfectly safe and economical to deliver plenty of heat to the steam under treatment. It ensures that all the water shall be converted into steam, and whatever heat may be delivered to the steam, over and above that necessary for the conversion of the water, is usefully employed in raising the temperature, and with it the pressure or, *per contra*, the volume of the steam itself, so that in any case it should be able to do more work. When the steam that is being superheated is confined, so that its volume cannot increase, temperature and pressure will

rise, and, providing that the full benefit of the increased pressure can be obtained by expansion, economy results. When the steam is not confined, say when it is being superheated on its way to the steam cylinder, expansion will take place, and the steam engine

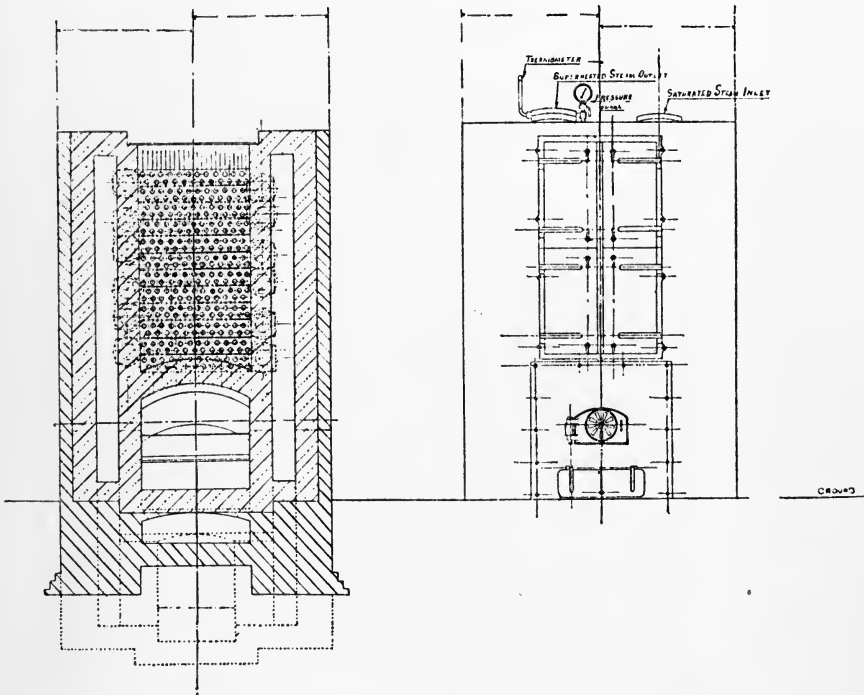

FIG. 68.—Transverse Section and Diagram of the Front of Messrs. Davey, Paxman, & Co.'s Separately Fired Superheater.

should receive the benefit of the larger volume of steam produced. As with all improvements, there are difficulties in the way of the application of superheating steam, but they are easily overcome. Superheated steam is at high temperatures, from 450° Fahr. upwards, and brass and gun-metal will not stand those temperatures. They disintegrate, in some cases practically breaking up into a powdery mass. In addition, only certain oils will stand the high temperatures. The difficulty of the valves, etc., has been overcome by the use of cast-iron specially prepared for the purpose, and the matter of the oil has been overcome by the use of special mineral oils. According to Professor Siebel, the great authority on refrigeration, superheating

the steam increases the efficiency of the engine using it in another way. Superheated steam, the professor states, has only one-fortieth the conductive ability for heat, to or from itself, that ordinary saturated steam, as it would come from the boiler, has. Hence it would give off much less of its heat to the cylinder walls, even when

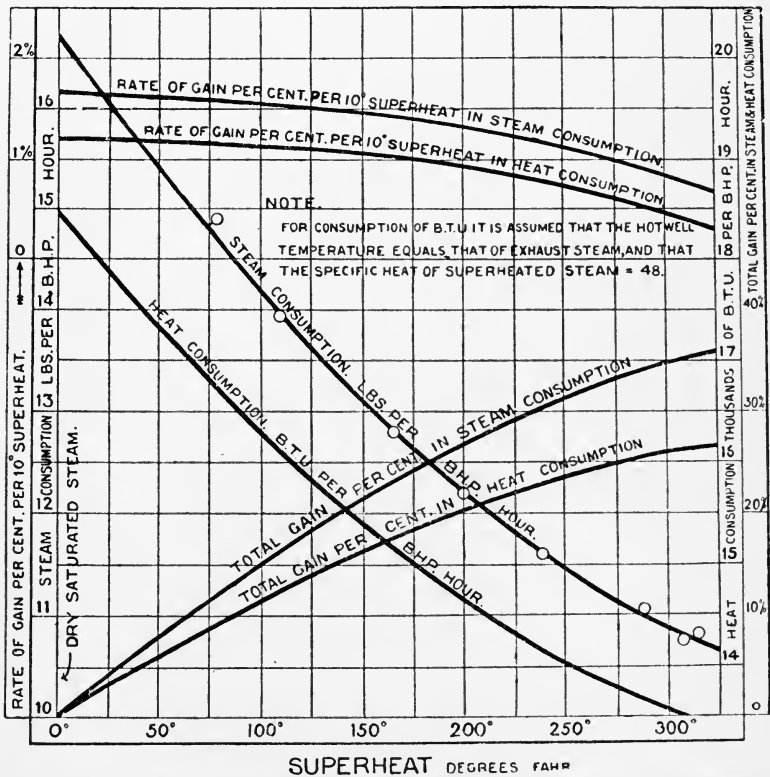

Fig. 69.—Curves showing the Advantages of different Degrees of Superheat. Reproduced by Permission from Messrs. Belliss & Morcom.

they are at a much lower temperature. Figs. 66, 67, and 68 show two forms of superheater, one heated by the boiler furnace gases, and one by a separate furnace, and Fig. 69 curves showing the advantages of superheating.

Condensers

Another source of economy in steam generation is the condenser. The object of the condenser is to reduce the pressure in front of the piston on the return stroke. Steam enters the cylinder behind the piston for a certain portion of the stroke. Its entry is then stopped, and it continues to drive the piston to the end of the stroke by its own expansion. And when the end of the stroke is reached, and the piston commences its next stroke, it has to drive the steam remaining in the cylinder in front of it, out through the exhaust port, and into

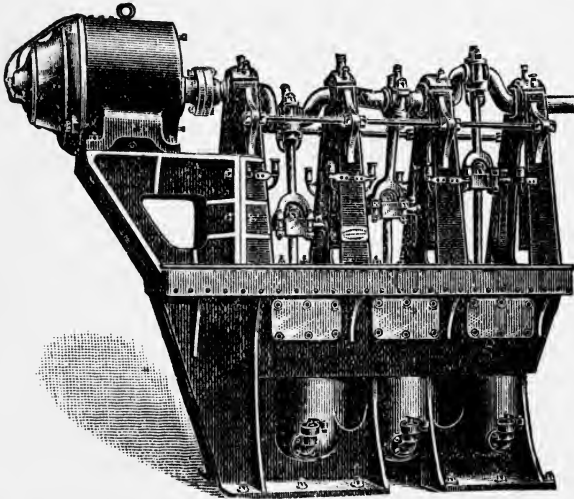

FIG. 70.—Edwards' Triple Air Pump, driven by Electric Motor as made by Messrs. Isaac Storey & Son.

the atmosphere, unless the steam is got rid of by condensation as soon as, or very quickly after, the return stroke commences. This means that the piston on its return stroke has to overcome the pressure remaining in the steam, plus that of the atmosphere, and the mean effective pressure available for driving the piston forward, is the mean of the successive pressures behind it, less the mean of the successive pressures in front of it. If the back pressure of the steam can be extinguished, it is equivalent to adding a certain number of pounds pressure to that of the steam behind the piston; and if, in addition, the pressure of the atmosphere can also be partially extinguished, this amount—5, 10, 12, or 13 lbs., as the case may be—is also added to the effective pressure behind the piston.

But it is not always economical to condense. It is only economical when the saving in the cost of generating a horse-power, obtained by condensing, is greater than the cost per horse-power of condensing. In all condensers water is employed for cooling, and water is often a very expensive commodity. In addition, the circulating water has to be pumped, and the power to drive the pump must come originally from the furnace of the boiler, and will require its own quota of coal. Further, for efficient condensation of steam, an air pump is necessary.

The steam is not instantaneously converted into water and allowed to run away harmlessly. In the jet and surface condensers it has to be pumped out of the condenser in which it is formed, and delivered to the hot well, or to whatever receptacle it may be consigned to; and, in addition, the air which is mixed more or less with the steam, and which remains mixed with the water into which the steam is converted, has also to be pumped out, and the air pump has to be driven, the power, as in the case of the circulating pump, coming from the boiler furnace in the first instance. Fig. 70 shows a motor-driven triple air pump, and Fig. 71, a section of the Edwards air pump, the one almost universally employed for condensers.

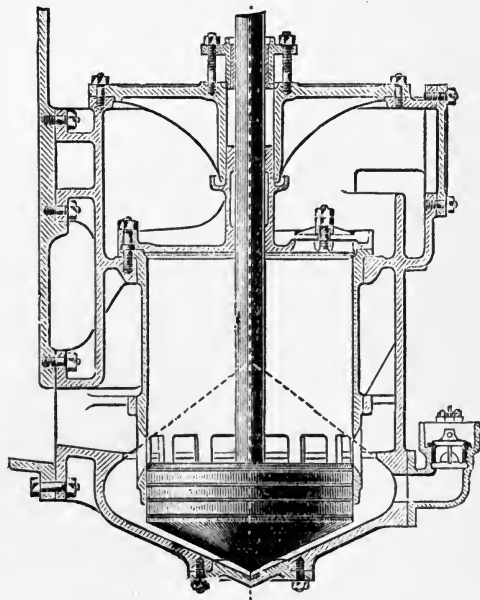

FIG. 71.—Section of Edwards' Air Pump, showing the Form of the Piston.

It is a very instructive sight, in the matter of condensing for steam purposes, to visit a large power station where steam turbines are employed. The condensing plant occupies a much larger space than the turbines, and the power absorbed by it is decidedly appreciable.

Forms of Condenser

There are three principal forms of condenser employed with steam engines—the surface condenser, the jet condenser, and the ejector condenser. The surface condenser, again, is made in two forms, the

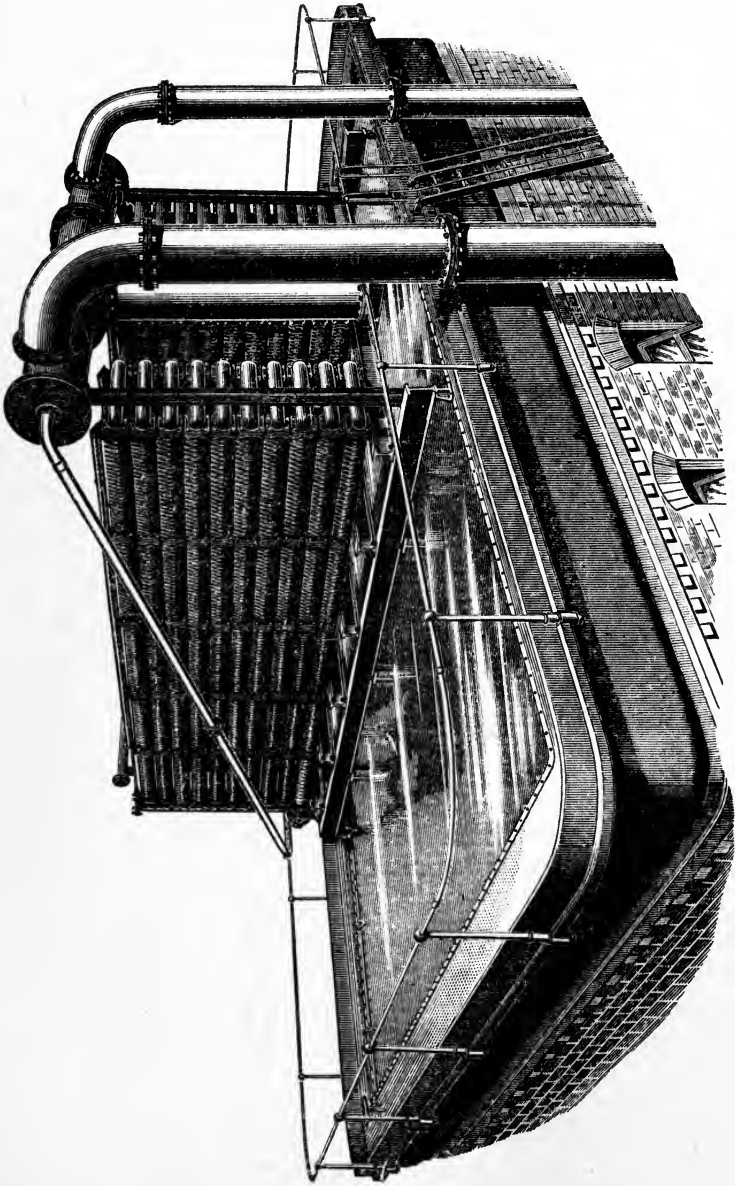

Fig. 72.—Ledward Evaporative Condenser with Tank. The Steam to be condensed passes through the Pipes in the Grids shown, the Cooling Water trickling over the Corrugated External Surfaces. The Condenser shown is fixed on the Roof of the Engine-house.

submerged condenser and the evaporative condenser. The best known forms of non-evaporative surface condensers consist of boxes of pipes, the water circulating through the pipes, and the steam passing through the box in the space left vacant by them. In the evaporative condenser, of which the Ledward is one of the best known, and which is shown in Fig. 72, there are successive coils of pipe, corrugated on the outside, standing above a tank, and having above them a perforated pipe, through which the water is distributed to the upper sections of the steam pipe. The water trickles down over the corrugations in the steam pipe, and is collected in the tank at the bottom, and made to do duty over and over again, the amount lost by evaporation being made good from the water-supply service, or cooling tower. The air pump is connected to one end of the steam pipe, the exhaust steam to the other.

In the jet condenser the steam enters the vessel in which it is to be condensed, and meets a jet of water broken up into a fine spray, the two mingling, the steam being condensed, and the whole being removed by a pump, arranged to carry off the circulating water, the

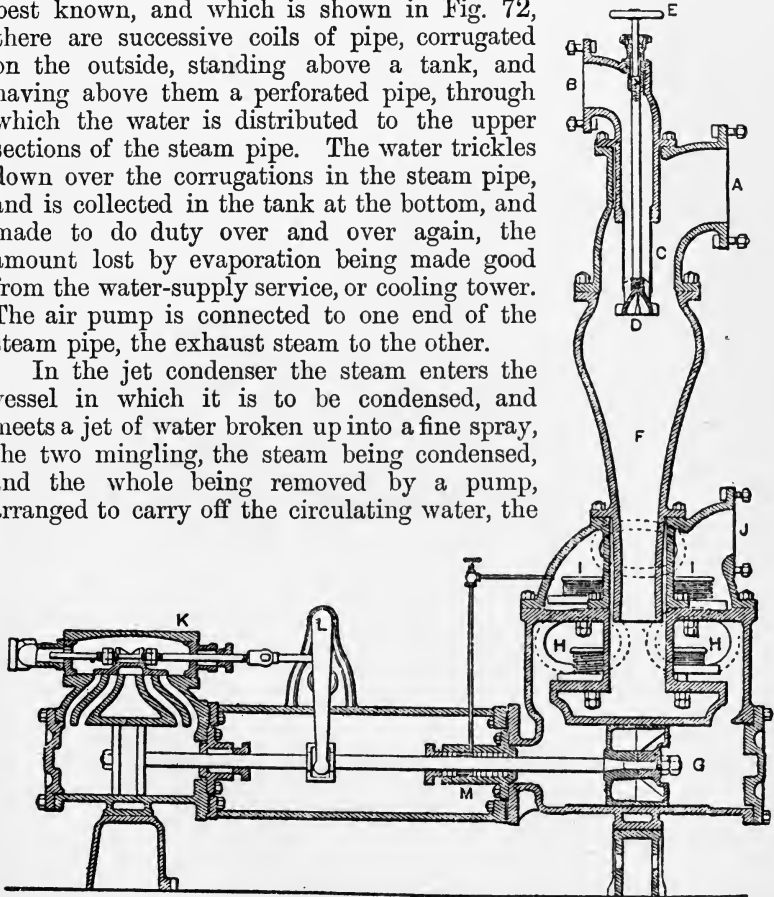

FIG. 73.—Section of Worthington Independent Jet Condenser.

condensed steam, and the air. Fig. 73 shows a Worthington jet condenser. In the ejector condenser the exhaust steam is made to impinge upon a stream of water passing through a vessel, into which the steam enters, the condensed steam being carried off with the stream of water. Fig. 74 shows a Ledward ejector condenser. The quantity

of cooling water required for each form of condenser will vary with the temperature of the water. It is from twenty to thirty-six times the

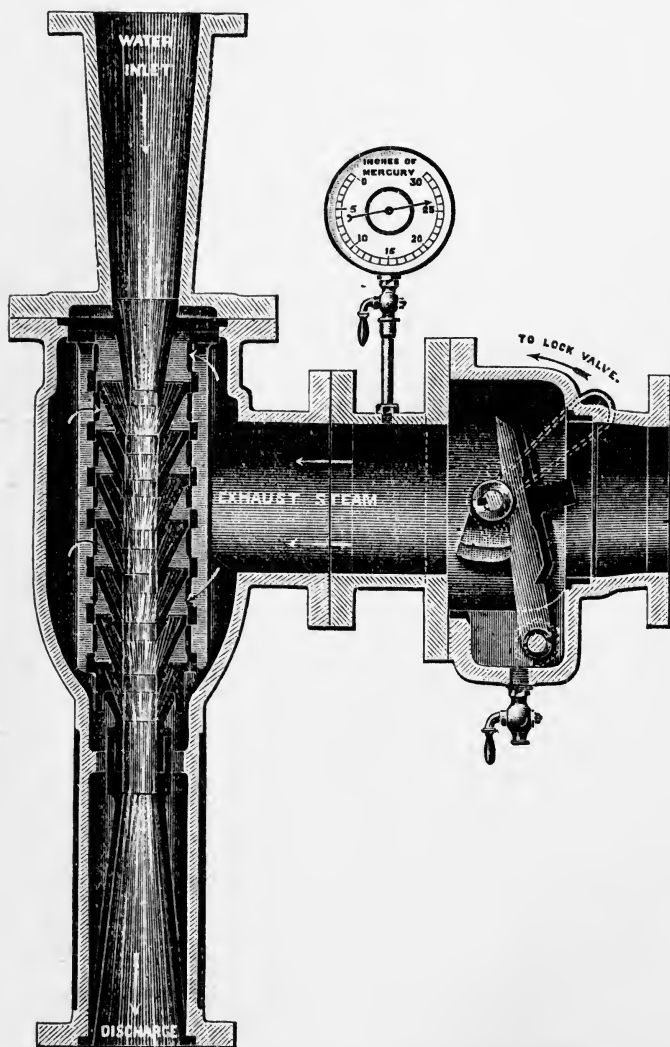

FIG. 74.—Section of Ledward Ejector Condenser.

weight of steam for surface condensers. For jet condensers the injection water allowed is from twenty-seven to thirty times the weight of

steam in temperate climates, and from thirty to thirty-five times in the tropics. For ejector condensers it is from thirty-seven to forty times the weight of the steam to be condensed. The surface condenser, and principally the non-evaporative form, finds most favour with engineers, particularly those who have had to design power stations, though the evaporative condenser is gradually making its way. There are, however, a good many jet and ejector condensers in use, one important

feature about them being the small space they occupy. The surface condenser, both evaporative and non-evaporative, is subject to one serious drawback, the increase of the thermal resistance between the cooling water and the steam, due to the deposit of grease and other substances on the surface of the pipes. In the case of the evaporative condenser, oxidation takes place on the outer surface of the pipes, and a deposit of grease on the inner surface, grease being almost invariably brought over from the steam cylinder by the steam, in the form of small globules of oil, from that employed for lubricating the

piston, in the same manner as it carries over the globules of water in the boiler. The deposit of grease upon the outer surface of the pipes of non-evaporative condensers is sometimes so great as to reduce the vacuum by as much as 10 to 12 inches. The drawback to the jet and ejector condensers is, that they are not so economical as the surface condensers with varying load, and particularly where sudden heavy loads may come on at any time. It is necessary in both forms that the quantity of water passing into the condenser shall be sufficient

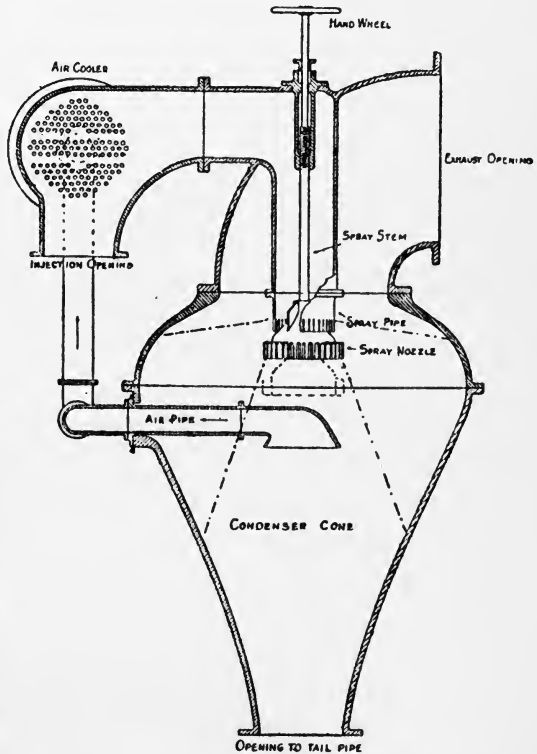

FIG. 75.—Section of Worthington Central Condenser.

to condense the largest quantity of steam that can be delivered to the condenser at any time. Hence, where the load varies from very small, at certain times of the day, to very sudden heavy loads at certain other times, the engineer is obliged to keep such a large quantity of water in circulation that the economy is very often doubtful. A case was mentioned to the writer of an electricity

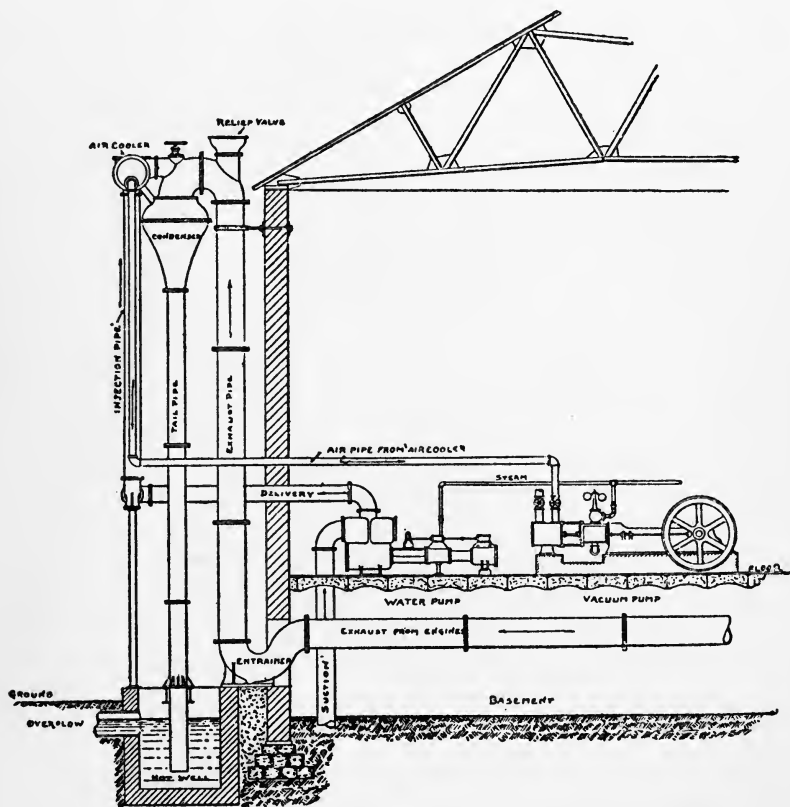

FIG. 76.—Sectional Diagram of Worthington Central Condensing Station with Pumps and Piping.

generating station in which an ejector condenser was in use. The engines employed were working very close to their full power, and it happened on one occasion that one of them broke down, but by disconnecting the condenser and stopping its pump, the remaining engines were able to deal successfully with the heaviest load the station had. Complaints are made also at times of both jet and

ejector condensers suddenly losing their vacuum. It should, perhaps, be mentioned that central condensing stations are being erected in different parts of the kingdom, to deal with the steam from groups of plants. They are usually on the jet, or ejector principle. The whole of the steam from the different plants is led to the condensing station, and there dealt with, usually in one or more large condensers. The economy of this arrangement arises from the variation, or what the present writer has termed the user factor. When a number of engines are at work, it is not often that they are all taking steam at the same rate at the same instant, and hence, if the steam from their exhausts can all be led to one condensing plant, considerable economy in cooling water can be obtained. Fig. 75 shows a section of a Worthington central condenser, and Fig. 76, a Worthington central condensing station.

Steam Turbines

There are practically four forms of steam turbine at present on the market, and there are two main lines upon which steam turbines are constructed, two of those on the market, the Parsons and De Laval, illustrate the two principles, they being constructed entirely in accordance with those principles, while the others are more or less modifications, in which both principles are made use of to a certain extent. In the Parsons turbine there is a shaft carrying upon it a number of circles made up of fan blades, the circles being of different diameters, as they are farther and farther from the steam entry port. The fan blades on the shaft run between fan blades fixed on the inner side of a cylindrical containing vessel, the cylinder becoming larger as it recedes from the entry port. The steam enters at one end of the cylinder, and it passes through the circles of fan blades and the shaft in succession, and in doing so it exerts a certain pressure upon each individual fan blade, the pressure being communicated to the shaft, the result being a turning movement. The pressure of the steam is resolved into two forces at right angles to each other, and it is the force in the direction of rotation of the shaft which causes it to move. The steam, as it passes through each circle of fan blades, loses a certain portion of its pressure, and it is for this reason that the successive batches of circles of fan blades are larger, as the distance from the steam entry port increases. The action is exactly the same as that of the steam in a compound engine, and the fan blades are made larger, so that the turning moment exerted by the steam upon each successive length of the shaft shall be as nearly the same as possible, the increased diameter of the circles of fan blades making up for the decreased pressures. In the Parsons turbine the

steam is admitted to the turbine cylinder in gusts, and not in a continuous stream. The duration of each gust is controlled by the governor, which again is controlled, either electrically by means of a solenoid, or by an ordinary governor of the centrifugal type. The core of the solenoid, when an electrical governor is employed, is hung from the end of a long lever, the short arm of which controls the valve of the steam relay. At regular intervals, which may be adjusted, the steam relay admits a certain quantity of steam to the turbine, and the valve is then immediately closed, the quantity of steam admitted being controlled by the time the valve is opened, very much as with an expansion governor controlling a slide valve. Where the ordinary centrifugal governor is employed, practically the same arrangement holds, but it is not controlled by variations in the electric circuit as with the electrical governor. It is controlled simply by variations in the load, increasing or decreasing the speed of the turbine, and spreading the arms of the governor, or the reverse. When the steam turbine is employed to drive an alternating current generator, an additional solenoid is added to the governor, connected in series with the work, the solenoid of the continuous current governor being connected as a shunt. The Parsons turbine is fixed on the same bed-plate with the generator it is to drive, its shaft being coupled directly to the shaft of the dynamo by a steel sleeve. The dynamo is, of course, constructed to run at the highest speeds at which the turbine runs, and this was for some time a serious difficulty in the matter of upkeep, the question of the brush contacts being a somewhat serious one at high speeds; this, however, has been completely overcome. One of the troubles in connection with a turbine of the pressure type, such as Parsons turbine, is the matter of end thrust of the shaft. Until recently, in the Parsons turbine, end thrust was provided for by the provision of grooved pistons or dummies, on the end of the turbine shaft, which fitted into grooves in the turbine case, and which, it was claimed, provide a steam-tight joint. Now it is balanced by pistons behind the entry port.

The Willans-Parsons Steam Turbine

Messrs. Willans & Robinson manufacture a modification of the Parsons turbine, one feature of which is the construction and general arrangement of the moving and guide blades. The individual blades are stamped out with a dove-tail section or "tang" at the end which is to be fixed either to the axle or to the casing, and at the other end is a short tongue provided for riveting into a shrouding. The blades, instead of being held simply by one end to the axle or the turbine case, are held between two rings, one called the foundation ring and

the other the shrouding ring. The foundation ring is secured to the axle or the turbine case, and the dove-tail section part of each blade is fixed in the foundation ring, and held there while the outer ends of the blades are secured by the short tongues mentioned, being passed through holes in the shrouding ring. Successive rings built up in this way are held on the axle and on the casing, the rings, as before, increasing in section as the pressure of the steam decreases. The rings containing the moving blades are thus practically held between the guide blades, the clearance space between the two being very small, and the necessary angle for the moving and guide blades being arranged in fixing them between the foundation and shrouding rings. The moving blades run practically as discs might do between other discs. The angles of the moving and guide blades are so arranged as to give the maximum effort from the steam passing through the successive rings of blades in the direction of rotation. Messrs. Willans & Robinson prefer to govern the admission of steam by a very powerful centrifugal governor of the ordinary type, having ball-bearings on all its working parts, the governor acting upon the throttle valve, and being driven by worm gearing on an extension of the main turbine shaft. The turbine case is made in two halves longitudinally, the dividing plane being horizontal, so that the upper half of the case can be thrown back by removing the bolts holding it in position, and the blades examined at any moment, as shown in Plate 4B.

Messrs. Willans & Robinson's turbines are made for outputs of from 250 to 7500 kilowatts, speeds ranging from 600 revolutions in the larger turbines to 3000 in the smaller.

The De Laval Turbine

In the De Laval turbine the pressure of the steam is expanded down to, or nearly to, atmospheric pressure before it is made to operate the turbine wheel. The turbine itself consists of a disc, upon the periphery of which are fixed small buckets, very similar in form, though much smaller, than those of some forms of water wheel. The turbine disc with its buckets is enclosed inside a case, and the steam is delivered to the buckets from nozzles fixed on one side of the turbine disc. The nozzles are so formed that the molecules of the steam as nearly as possible take a straight path from the nozzle into the turbine bucket, and the work the turbine is doing may be controlled by using a greater or less number of the nozzles. The operation of the turbine is very similar to that of some forms of water wheel. The buckets are filled with steam which is issuing from the nozzle at considerable velocity, and the weight and velocity of the

steam push the buckets away from the nozzle, the steam escaping on the other side of the disc to the condenser. The De Laval turbine is always geared down by means of spur gearing contained in a gear chamber, fixed on the same bed plate as the turbine, the power being taken from the axle of the last wheel of the gearing, the second motion shaft. The turbine nozzles have valves attached to them by means of which the quantity of steam passing through them can be controlled, so that variation of load is provided for by changing the number of nozzles at work, and by throttling the steam passing through the nozzles, or the reverse. The governor is of the centrifugal type, with special arrangements for sensitive government, and assisted by a vacuum valve when the turbine is run condensing.

The Curtis Turbine

The Curtis turbine may be taken as a modification of the De Laval turbine, but with special arrangements allowing the steam to work expansively, as in the Parsons turbine. The turbine consists of a number of moving discs fixed horizontally upon a vertical shaft, moving above a certain number of stationary discs, each disc having a certain number of buckets, similar to those on the De Laval turbine, on its periphery, the steam passing in succession through the moving and stationary discs. The successive discs increase in size from the top where the steam enters to the bottom where it leaves, the whole apparatus being fixed vertically. The discs are arranged in sets, and between successive sets there is a diaphragm which practically makes each section a separate turbine with its own steam chest. The Curtis turbine is employed principally for driving electric generators, at which it has achieved a considerable amount of success, the generator being fixed above the upper disc of the turbine, and arranged for its armature or moving member to rotate in a horizontal plane upon a vertical axis, the shafts of the generator of the turbine being mechanically connected, as in other apparatus that have been described. The Curtis turbine for any given size occupies a much smaller floor space than any other form of steam motor, but it is claimed by makers of other forms of turbine and of reciprocating engines that very little advantage is gained, since the foundations upon which the turbine rests must be stronger in proportion. Further, a special floating bearing must be provided for the lower end of the vertical spindle of the turbine, and the lubrication of this bearing requires very careful attention. In practice the lower end of the spindle is supported by what is practically hydraulic pressure. The Curtis turbine is usually governed electrically.

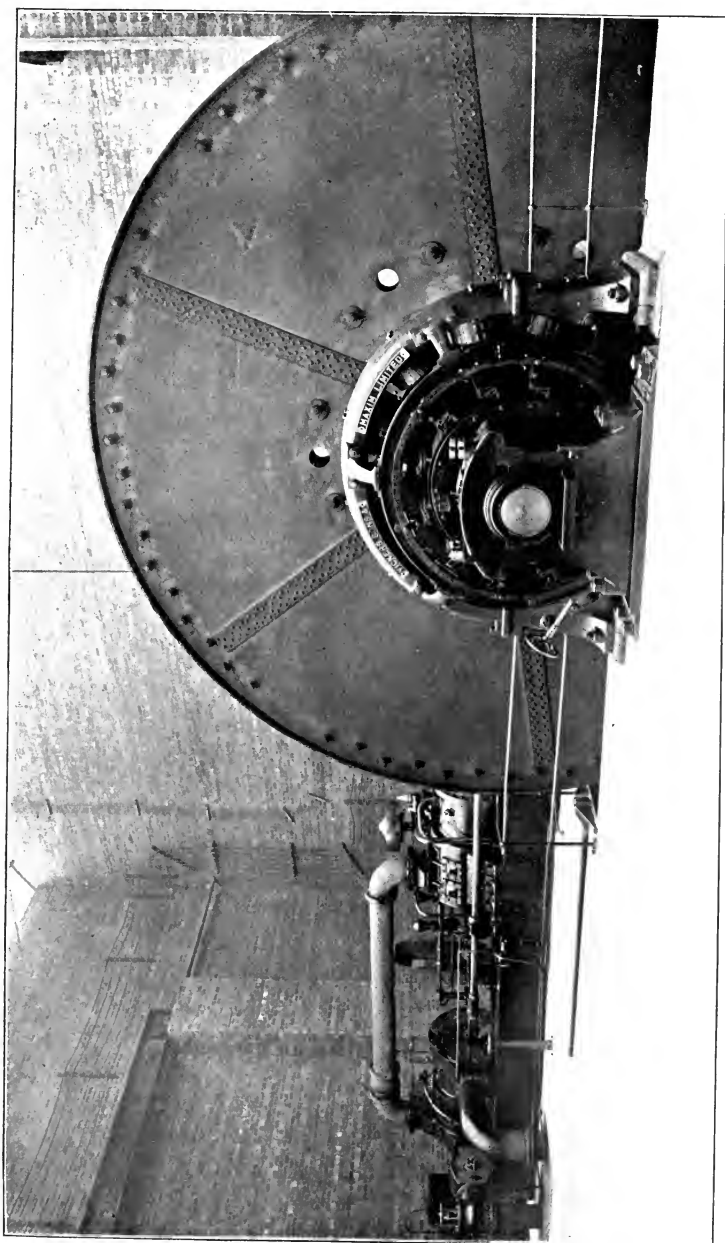

PLATE 5.—Oechelhausen Two Cycle Gas Engine, made by Messrs. Beardmore, directly connected to a Vickers-Maxim Multipolar Continuous Current Generator.

The Westinghouse Turbine

The Westinghouse turbine is another modification in which some of the features of the Parsons and some of those of the Curtis are included. The turbine case is cylindrical, and stands horizontally, very much as the Parsons turbine. Steam is led into the turbine in the centre, and there are a number of circles of fan blades fixed upon the revolving shaft, the circles becoming larger in section as the steam entry port is left behind, but the last portion of the work of the steam is performed by discs very similar to those of the Curtis turbine, except that they are fixed vertically upon horizontal axes, with the buckets fixed on the edge of their peripheries. The remainder of the arrangement is very similar to that described for other turbines.

Turbines using Exhaust Steam

Professor Rateau has made this subject particularly his own, and the arrangement he has devised is a turbine which is a modified form of those that have been described, and is employed to drive any apparatus, such as a dynamo, a fan, or anything about a mine, the turbine using the exhaust steam from the winding and other engines. It has been explained in previous pages that a large amount of energy remains in the steam which exhausts to the atmosphere, and it is this energy that is utilized in the Rateau turbine. There are certain difficulties, however, as mining engineers will understand, in the application of exhaust steam owing to the intermittent working of the engines about the mine, and therefore varying the supply of exhaust steam. To meet this, Professor Rateau has designed a thermal storage apparatus, consisting of a boiler shell loaded with old iron rails, sleepers, etc. When the exhaust steam is more than is required for driving the turbine, the surplus is carried into the thermal store, and is used up in heating the mass of iron. When the supply of exhaust steam runs short, the pressure in the thermal store being reduced, steam is formed there, and is supplied to the turbine, making up what is wanting from the engine. It is a necessary condition of using this arrangement, that the turbine shall be employed to perform work that can be dealt with by a little less than the average quantity of exhaust steam throughout the day. In addition to this, Professor Rateau, in the installations that he has laid down, and in those that have been established in this country, provides for an automatic supply of steam from the boiler service, if the supply from the exhaust and from the thermal store falls below a certain pressure.

Steam Turbines and Condensing

One of the most important features in connection with steam turbines is the fact that, while they run very economically when the steam exhausts into the condenser, if condensation is not practicable the economy is very considerably reduced, the steam consumption going up very considerably. The economy of the steam turbine also increases with the vacuum maintained in the condenser, and it is claimed by makers of reciprocating engines that the cost of creating the vacuum sometimes neutralizes the economy of steam consumption. It is a very striking experience to visit a large electricity generating station, such as that of the Metropolitan District Railway at Lot's Road, Chelsea, where steam turbines are employed. The steam turbines there are capable of generating 5500 K.W. each, or, say, 7000 H.P., and the small space occupied by the turbine and the alternator it is driving is very marked, but on going below the floor, where the turbo-generators are fixed, one finds a very large quantity of apparatus on the floor below, which are necessary for providing the condenser vacuum required if the turbines are to work economically, the space occupied by the condensing plant for each turbo being many times that occupied by the turbo itself, and the power required for each condensing plant being very appreciable. It is claimed by Mr. Parsons, however, who has designed special apparatus for obtaining high vacua, that the total cost of condensing does not exceed $1\frac{1}{2}$ per cent. of the output, while it creates an economy of 4 to 5 per cent. in the coal bill.

Cooling Towers and Ponds

The crux of the condenser problem is nearly always the cost of the cooling water. Where the town service is the only water available, the cost is nearly always prohibitive, and it is found that in large towns, unless there are independent sources of supply, such as wells or rivers, condensing is not employed. In London, for instance, the exhaust steam is very often delivered into the chimney. Where a source of water, such as a stream, is available, the question turns upon the cost of pumping. An instance that has come under the writer's notice is of interest. In one of the electricity generating stations at Newcastle-on-Tyne, water is pumped from the river for the condensers, and it is allowed, after passing through the condensers, to run down to the river again. The generating station is about 90 feet above the river and the pumping plant is threefold. There is a centrifugal pump driven by an electric motor taking

current from the generating station, and on the same axle a water turbine. The centrifugal pump delivers the water at the generating station, and the return water from the condenser drives the water turbine, so that the electric motor has only to make up the difference between the net power delivered by the turbine to the common axle and the power required by the centrifugal pump.

There are many cases, however, where water is scarce, and the cost of pumping any water available is high; and where, if condensing is to be employed, the water must be used over and over again, and for that purpose must be cooled after passing through the condenser. Perhaps the simplest and most economical arrangement of this kind, where it can be employed, is that which is so common in connection with Lancashire cotton mills, and which can be so easily arranged at a mine. There is nearly always a pond holding a large quantity of water, and with a large surface, close to the engine-house. The cooling water is pumped from the pond to the condenser, and is allowed to return from the condenser to the pond. Evaporation is constantly taking place from the surface of the pond, more particularly in hot weather, and this, combined with the large mass of water employed, is sufficient to maintain the cooling water at a sufficiently low temperature. It is a simple calculation to find how much water, and what size pond, with what extent of surface, must be provided. Lancashire cotton mill steam plants, it is well known, are perhaps the most economical power generators in the world. Another method is by the aid of a cooling tower.

The cooling tower is based on exactly the same principles as the evaporative condenser. When water evaporates, whether it is converted into steam, or into vapour that is held in the atmosphere under the various forms we are familiar with, and that becomes visible in the form of fog and of cloud, a certain definite quantity of heat is required to enable each pound or gallon of water to assume the form of vapour. The actual quantity of heat required to form vapour, as distinguished from the quantity of heat required to form steam, has not, the author believes, been accurately determined, but it will be safe to assume that it is not far removed from the quantity required to form steam. For the purposes of calculation, and as a safe guide, the author is accustomed to take 900 B.Th. Units per pound of water evaporated at temperatures lower than boiling-point. Secondly, the atmosphere has the property of absorbing a certain quantity of moisture, the quantity varying with the temperature. The quantity does not increase simply in the same ratio as the temperature; that is to say, at 40° the capacity of the atmosphere for absorbing is not twice that at 20° ; it is more than twice, and at 80° it is very much more than twice that at 40° . The rate of increase follows a hyperbolic curve, the latter portion of the curve being very

steep indeed, almost a vertical line, while the early portion is almost a horizontal line, the consequence being that the rate of increase of the capacity for moisture is very rapid when comparatively high temperatures are reached. This means, of course, that warm air, having a high capacity for water vapour, has also considerable evaporative effect, and therefore a considerable cooling effect. The cooling of the water in a cooling tower is effected by the evaporation of a small portion of the water, the heat required in this case being taken, to a large extent, from the water itself, and this performing the operation of cooling. But this is not the whole story. In addition to the above, every cubic foot or cubic yard of air has its capacity for absorbing moisture at each temperature, and therefore, if air is made to pass over the surface of the water that is to be cooled, and, in particular, if the water is broken up, as will be explained, into very fine particles, so that the air can reach every particle, or a large number of them, the cooling effect will then depend upon the quantity of air passing through the cooling tower, and the capacity of each cubic foot of air for absorbing vapour at its then temperature, and under the conditions ruling. But there is yet another factor in the problem. If the air is already fully saturated, if it has already absorbed all the moisture it is capable of at that temperature, it cannot absorb any more, and it will not only not produce any evaporative effect, and therefore no cooling effect, but it is more than probable that the air itself may be slightly cooled by coming into contact with bodies that will absorb some of its heat, and then its capacity for holding moisture being lowered, it will deposit vapour upon any substance that is at hand, in this case upon the particles of water, and in place of cooling the water, the latent heat of the vapour deposited from the air will be delivered to the water, and will raise its temperature instead of lowering it. The question whether vapour shall be deposited in the form of water from the air, or whether the air shall absorb water in the form of vapour from the water in the cooling tower, depends upon the relative tensions of the vapour in the air, and the vapour that is issuing from the water. Evaporation takes place from the surfaces of liquids at all temperatures, unless it is prevented by pressure upon the surface of the liquid, the pressure in question being exerted by the vapour in the atmosphere, or gas, impinging upon the liquid. When vapour is issuing from the surface of a liquid, it has a certain tension, and the vapour which is present in the atmosphere also has its own tension. When the tension of the two are equal, no evaporation takes place, and no deposit of vapour from the atmosphere. When the tension of the vapour emanating from the liquid is greater than that of the vapour already present in the atmosphere, evaporation takes place, and when the reverse of these conditions rules, deposit

takes place. The tension of the vapour in the atmosphere varies with the temperature, and with the quantity of vapour already present.

Forms of Cooling Towers

Cooling towers are of various forms. In some of them natural draught is made use of; that is to say, the tower is built in the form of a chimney, and the air passes through the chimney for the same reason that it passes up the chimney of a fireplace or a furnace. In other forms, fans are employed to force air up the tower, the fans being driven by any convenient source of power, an electric motor being a favourite one, though a small steam or gas engine will answer equally as well. Where the cooling tower depends upon natural draught, the chimney, which may be of wood, iron, brick, or any substance that is preferred, is built of a very much greater height than is necessary where fans are employed, and for the same reason as with forced draught. The apparatus, in fact, consists of two distinct parts—the cooling portion proper, and the chimney which is to create the draught. In all forms of cooling towers the water is divided up by various devices, and is made to trickle down, or to fall down in a finely divided spray from the top of the cooling tower, and is collected in a tank or pond at the bottom. The devices for breaking up the water consist principally of wooden troughs, sometimes set on edge, of wooden slats set on edge, of mats of various forms galvanized iron being a favourite one, also hung on edge. The Worthington Co. use glazed pipes standing vertically in successive rows, as shown in Fig. 77. The water is either carried by gravity, where that is possible, or pumped to the top of the cooling tower, and is there delivered to the upper portion of the arrangements for breaking it up, the whole of the tower being filled with the slats or mats, or whatever may be employed, and the water dropping from one to the other in its descent. Whatever the form of cooling tower, the rule which holds in all cases of this kind applies, the air enters at the bottom of the tower, and meets the water as it descends, the coolest air meeting the coolest water at the bottom, and the air that is charged with the largest quantity of vapour meeting the warmest water at the top. In the chimney form of cooling tower, the chimney is built immediately on top of the cooling arrangements, whatever they may be, and the latter are sometimes spread out so as to occupy a large area, the chimney rising from the centre, the vapour, as usual, issuing from the top of the chimney with the air. There is also another type of natural-draught cooling tower, in which the cooling arrangements, the laths, etc., are stretched out over a large area, and in which the air draught is obtained from the force of the wind only, there being

no chimney. In this form of cooling tower, louvre boards are fitted at each end of the tower, and, if necessary at the sides, the boards

being arranged to open or close by means of levers, in a similar manner to venetian blinds. When there is very little air about, the louvres are thrown wide open, and they are closed more or less, according to the force of the wind. The cooling towers in which fans are employed are, as explained above, shorter than those in which chimney draught is made use of. They have, however, a short chimney containing a water baffle above the cooling arrangements, the object being to catch any water that may be carried upwards by the mechanical action of the air upon the water, and so lost by being carried away. The fan cooling towers are made of wood, iron, brick, concrete, and any other convenient substance. The fan is placed at the bottom of the tower, the water being led to the top, and the arrangements for breaking the water up

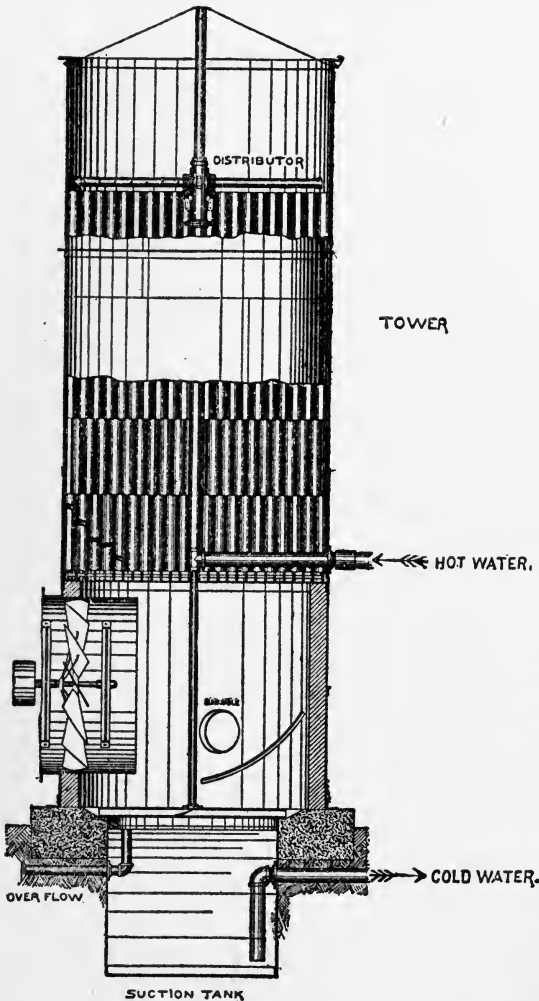

FIG. 77.—Section of Worthington Cooling Tower. The Earthenware Pipes used for breaking up the Water are shown, also the Fan and other Arrangements.

into minute globules being the same as in the chimney cooling tower. The size of the fan will be a matter of calculation, and

will depend upon the quantity of air that must be driven through the tower, this again depending upon the temperature and the tension of the vapour in the air, as opposed to that of the water to be cooled. The fan must be of sufficient size, and driven by sufficient power to provide a sufficiently powerful current of air under the worst conditions that can rule; that is to say, with the smallest difference of tension between the two vapours. Cooling towers are made sometimes circular, with a single fan, sometimes two circular towers are placed side by side, each with its own fan, and sometimes a rectangular section is adopted, the tower being divided into two or more sections, each having its own fan. The air for the cooling tower may be taken directly from the atmosphere, or it may be cooled, or warmed, or dried on its way to the cooling tower. It is evident that once it is determined to handle the air mechanically—that is, to perform the operations of cooling mechanically—the handling can be extended, and the air can be taken through any other apparatus, such as for warming and drying, that may be convenient; but it must be borne in mind that the cost of warming and cooling or drying, must be taken account of in the balance sheet.

The question of condensing, as previously explained, depends almost entirely upon the cost of the water employed, and everything which tends to add to the cost of the water adds to the cost of condensing, and reduces the economy and advantage. Messrs. Korting Bros. and others have developed an arrangement in connection with cooling ponds, in which pipes are laid in rows longitudinally across the pond, supported on baulks of wood or blocks of stone, or in any convenient way, and nozzles are fixed at intervals along the pipes, the water issuing in sprays from the nozzles, and falling into the pond. Messrs. Korting state that with 17 feet head of water, each nozzle will provide a cooling space of 60 square feet, and that 100 gallons per hour per nozzle may be cooled from a temperature of 110° Fahr. to 75° Fahr., with a loss of only 3 per cent. of the water sprayed. This method, it will be seen, is open to the objection that the water is blown away by the wind when it is strong, unless some provision is made for protecting it.

All forms of cooling apparatus are subject to the same fault that is present in the evaporative condenser, viz. the deposit of some of the salts contained in the water upon the appliances arranged for breaking the water up, and the filling up of holes, the filling up of troughs, and the wearing of slats and of mats, by chemical action, where there are any salts present in the water, and for this reason wooden boards taking the form of somewhat deep troughs of triangular section, and similar arrangements have found more favour in the eyes of many engineers, than the apparatus in which a more perfect

breaking-up of the water into spray is arrived at, because these forms of apparatus are less liable to get out of order, and the results are less liable to change than those in which the holes, etc., are liable to be partially or wholly filled up. The problem involved in handling cooling water, though the calculations are very simple, is itself by no means so simple as it looks at first sight. If a certain quantity of gas or steam has to be condensed per hour, a certain quantity of cooling water must also be provided per hour, and with certain forms of condensing apparatus the quantity of cooling water may have to be increased as pipe-cleaning time recedes, as the deposit upon the pipes increases, and the quantity of water may also have to be increased, owing to its temperature having increased with the season of the year. If the cooling tower is to be successful, the engineer who has it under his charge must have sufficient margin in its capacity for cooling, to deal with all these variations, and that in spite of the losses by evaporation, by wind, and other sources.

Gas and Oil Power. Producer and Kindred Gas

Any gas engine may be operated by illuminating gas, or by producer, or other gas; but the power available, the effective horsepower, is approximately twenty per cent. less when producer gas is employed than when illuminating gas is used. There are two gases that are produced in industrial operations that for a long time were wasted, but which are now gradually coming into use for generating power—blast furnace gas and coke-oven gas. In the process of iron smelting, iron ore, coke, and limestone are burnt together in the furnace, with the object of separating the oxygen and other substances from the metallic iron in the ore. The furnace is fed by a blast of air, forced in by an engine, hence the name "blast furnace;" and in the process a large quantity of carbonic oxide is formed. After the iron has been separated from its ore, there is a large volume of hot gas rising from the top of the furnace, consisting very largely of CO. In the early days, and in old furnaces even now, the gases may be seen coming away from the top of the furnace, lighting up the neighbourhood, but wasting a large quantity of energy. In the modern blast furnace, a portion of the heat of the gases coming over from the furnace is made use of in the "hot blast stoves," in which the air for the blast is heated on its way to the furnace, but there is a large quantity remaining, and in composition it very closely resembles some of the producer gases, its calorific value being about 130 units per cubic foot. Before it can be used in a gas engine, however, blast furnace gas must be well cleaned. With the gas itself a large quantity of dust comes over that would be fatal to the working of

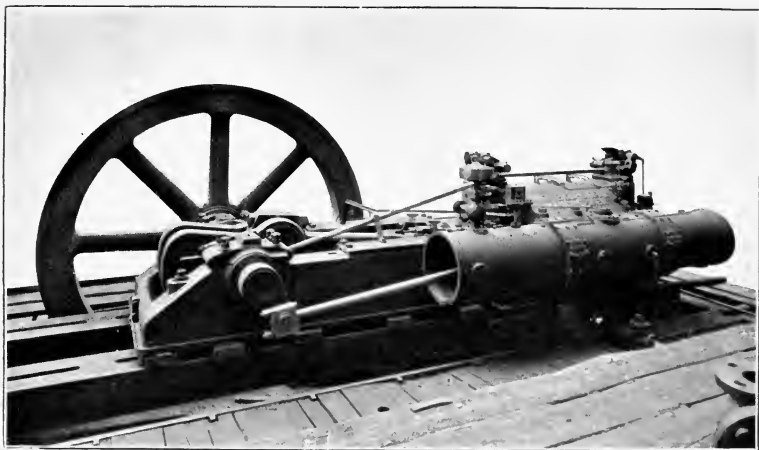

PLATE 6A.—The Körting Two Cycle Gas Engine, made by Messrs. Mather & Platt in the United Kingdom.

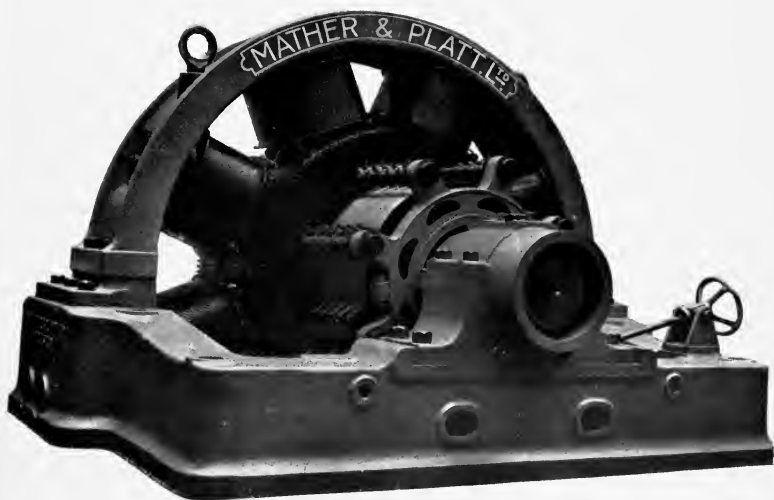

PLATE 6B.—Multipolar Continuous Current Generator made by Messrs. Mather & Platt. It will be noticed that the Upper Half of the Field Coils and Enclosing Ring can be lifted so that the Armature can be got at.

[To face p. 152.]

any gas engine. There are various methods of cleaning the gas, which need not be detailed here, by fans passing the gas through water in settling tanks, and others. All the difficulties have been so satisfactorily overcome that at several large ironworks the gas is employed in driving engines up to 1000 H.P. in this country, and to very much higher powers on the Continent. A point that must always be looked out for in all gas, except that supplied by gas undertakers in towns, is the tarry compounds that are formed in gas making. These must always be extracted before the gas is allowed to enter the engine, or they will lead to trouble with the valves, and in the cylinder, as some of the tarry matter is left behind after the exhaust gases are driven out. This will be in addition to the matter of the dust.

In the process of coke making, which is very similar to that of gas making, as carried out in town gas works, up to a certain point, there is a large quantity of gas given off, which has a much higher calorific value than either blast furnace or producer gas, as it is so rich in hydrocarbons. Its calorific value may be taken as about 400 heat units per cubic foot. A portion of the gas, approximately half that given off, is used to heat the retorts in which the coal is being formed into coke, but the remainder is available for use either for firing boilers, or in internal combustion engines. It is employed at the present time in both ways, with very economical results.

Producer Gas

Producer gas goes by several different names—water gas and others—but all forms are produced on some variation of the one method. Coal or coke is raised to incandescence, and steam or steam and air are driven through it, the heat causing the steam to be decomposed into its components, oxygen and hydrogen, this being followed by the combination of both with some of the carbon of the fuel. The calorific value of the different forms of gas runs from 130 heat units per cubic foot to 200 heat units. In some forms of producers the generation of gas is only one part of the operation, what are termed by-products being considered of as much, if not more, importance than the gas. Mond gas, of which so much has been heard from time to time, and of which so much is hoped in the matter of distribution of power by gas, is essentially a by-product process. There is hardly space to go into it here, but it may be mentioned that the process has been very carefully and scientifically worked out, heat being economized to the utmost; and the by-products, the principal of which is sulphate of ammonia, which are of considerable manurial value, being continuously produced, gas

being rather a by-product than the others. The calorific value of Mond gas ranges from 130 heat units to 140 per cubic foot. In most of the earlier producer plants, the generation of gas was not continuous, a process of changing over or recharging having to be gone through at certain periods, while storage was necessary in some cases, when the engines using the gas were not working continuously through the twenty-four hours.

The Suction Gas Producer

In the latest apparatus, however, which has only been placed on the market in recent years, all of these difficulties have been overcome. The gas is produced as and when it is wanted, its generation being controlled by the engine itself. In the suction apparatus, the draft necessary for keeping the furnace in which the gas is being generated in operation is created by the suction stroke of the engine. The producer consists of an iron cylinder, generally insulated thermally and lined with firebrick, in which the fuel rests on a grate, with an ashpan below, and with a hopper containing a supply of fuel above. There is a small boiler for generating steam, usually in the form of a ring, surrounding the top of the furnace. The furnace is fed with air from outside, and with steam from the boiler, the steam and air being led together to the bottom of the furnace by pipes arranged for the purpose. For starting the apparatus, a small fan is provided, which forces air through the fuel when it is lighted, and until sufficient gas is generated and enough heat to enable the fan to be dispensed with. The air and steam, as explained, combine with the carbon, forming principally CO and CO_2 , with a small quantity of CH_4 , and the liberation of a small quantity of free hydrogen. Anthracite coal is the fuel preferred for the suction gas producer, because it is so rich in carbon, and coke is even better if it is free from sulphur; but all forms of coal may be used, provided that proper scrubbing apparatus is fixed in connection with the producer. The scrubber consists of one or more cylinders, filled with coke or sawdust, the former being preferable. Above the scrubber is an arrangement for allowing a thin, sprayed stream of water to trickle constantly down, over and through the coke, or the sawdust. The gas to be scrubbed enters the cylinder at the bottom, and passes up through the coke or the sawdust, meeting the stream of water trickling down, and parting with all the tarry matters it carries, if the operation is properly carried out. It will be evident that, within certain limits, the operation of scrubbing can be carried as far as you please. The gas may be subjected to the action of as much water carried on the surface of as much coke as you like, and it is only

necessary that the process shall be carried far enough for the gas to come out free of all tarry products. After passing through the scrubber, the gas is taken to what is practically a receiver, called the expansion box, from which it is drawn by the engine at the suction stroke. When the engine draws gas from the receiver, the pressure there is lowered, and consequently the pressures at different points, right back to the boiler and furnace, air and steam being then supplied to the furnace in exact proportion to the quantity of gas that has been taken from the receiver. When the engine stops, the draught is automatically cut off, no air or steam passes to the furnace, and no gas is made. In starting the producer, say in the morning, the generation of gas is tested from point to point by gas cocks fixed for the purpose, where the gas can be burnt in a jet. It is known by a characteristic blue flame, and a smell of its own that cannot easily be mistaken when it has once been experienced. The smell is quite different from that of ordinary illuminating gas. The suction gas producer is to a gas engine what the boiler is to a steam engine, with the advantage that it requires very much less attention, and less fuel for stand-by purposes, and it takes very much less time to generate sufficient gas to start the engine than the average boiler does to make steam. Another advantage is claimed for the suction apparatus, viz. that the pressure within the apparatus, except during the short period in which the fan is in operation, is below that of the atmosphere, and therefore leakage is very much less likely to take place, than with gas delivered under a certain pressure from the town supply service. It is wise, however, to arrange that the producer house is well ventilated. The suction apparatus also takes up a comparatively small space, and requires no chimney, such as is necessary with a boiler. From 80 to 100 cubic feet of producer or blast furnace gas is required per brake horsepower per hour. With coke-oven gas, a smaller quantity is required, approximately in the inverse proportion to the calorific values of the different gases. It varies with the fuel employed and other things, as well as with the attendance, so that no absolute rule can be given. It is wise, however, in calculations, to allow 100 cubic feet per B.H.P. for producer and blast furnace gases, and from 35 to 40 cubic feet with coke-oven gas. The quantity of fuel consumed with the producer gas is from three-quarters to one pound and a quarter per B.H.P., and the quantity of water required for steam, and for scrubbing runs from 1 to 2 gallons per B.H.P. per hour. Of this, approximately one-eighth to one-quarter of a gallon per B.H.P. is used for steam, and the remainder for scrubbing the gas. The water required for the latter can be employed over and over again, if desired, by proper arrangement; but as any kind of water almost can be used, using over and over again is not of importance.

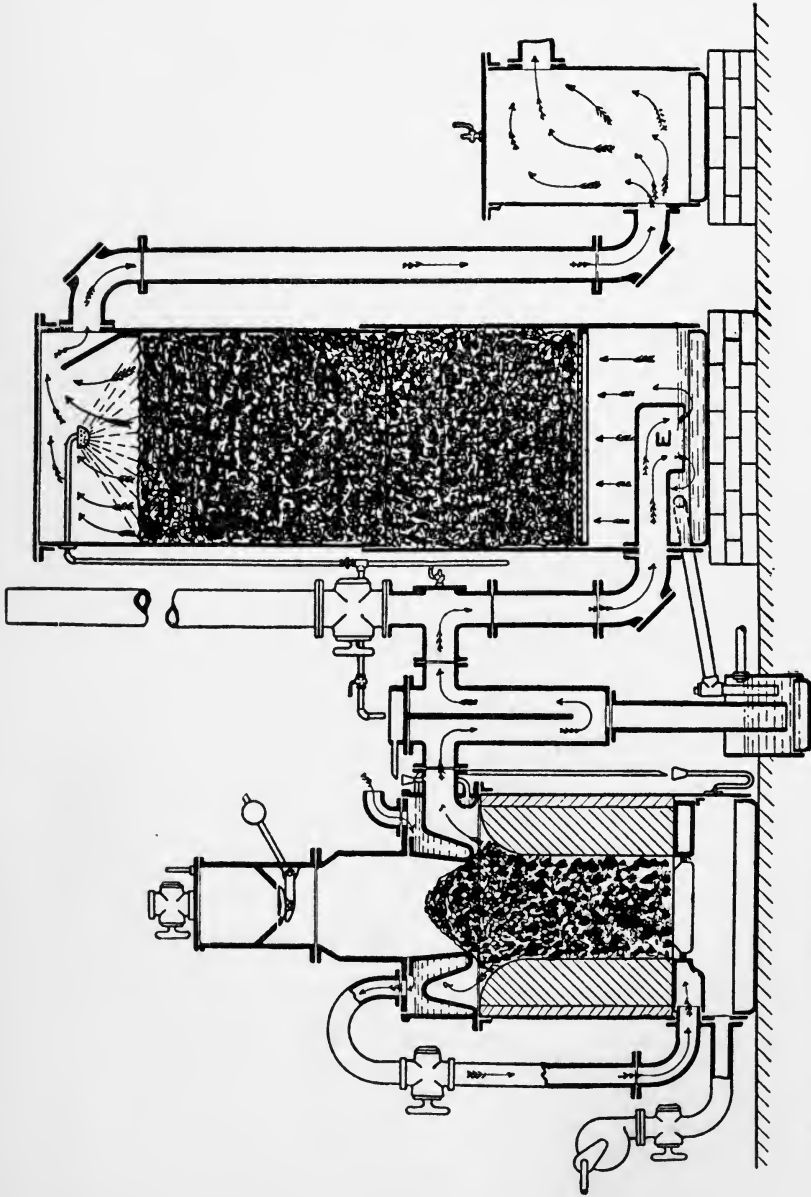

FIG. 78.—Longitudinal Section of the Campbell Gas Co.'s Suction Gas Producer. The Producer is shown on the Left, the Scrubber in the Centre, and the Gas Receiver on the Right. The Course of the Gas is shown by the Arrows.

Some suction plants are arranged to use very little water on the scrubbers.

The coke or sawdust in the scrubber has to be either changed or cleaned periodically, the time depending upon the fuel, the water, and the material in the scrubber. Fig. 78 shows a section of a Campbell suction gas producer.

The Internal Combustion Engine

The engines in which gas, and the vapour of oil or petrol are used to generate mechanical power, and which are known as internal combustion engines, are very different in operation from steam engines. While with steam engines it is necessary to have a steam boiler to generate the steam, that is afterwards employed in driving the engine, with gas and oil engines the whole of the work is performed in the cylinder of the engine itself, the mixture of gas and air contained in the cylinder performing the same office as the steam does in the steam engine. It will be seen at once what a very convenient arrangement this is. Gas may be generated miles away, brought to the works in pipes, and the necessary power created by the consumption of the gas in the engine itself. Or, *per contra*, gas may be generated on the ground and led to the engine; or, again, oil may be carried to the works in any convenient manner, vaporized, and used in the engine. With the exception of a few of the later forms, all internal combustion engines work on what is called the Otto cycle, and all are constructed on very much the same lines. There is a cylinder, open at one end, in which a solid piston moves to and fro, operating a connecting rod which communicates its motion to the driving shaft of the engine. The piston receives a violent impulse once in every four strokes, which is once in every two revolutions of the crankshaft. The violent impulse is created by an explosion of a mixture of gas, or oil vapour, and air. The action is as follows. Commencing at what is termed the suction stroke of the cycle, the first stroke of the piston outwards, as the piston moves, the space left vacant is occupied by a mixture of gas and air, valves arranged for the purpose, somewhat similar to the suction valves of air compressors, being open during that period, and the extent to which they are open being controlled, in the latest patterns of gas and oil engines, by the work the engine is performing. The power, it will be understood, is obtained by the combustion of the gases which are present. In ordinary town gas there is a large percentage of a carburetted hydrogen and of hydrogen gases. Both of these, the carburetted hydrogen gas being first decomposed, combine readily with the oxygen gas in the air that is admitted with the gas, and in doing

so liberate a certain definite number of heat units. With ordinary town gas, from 600 to 700 B.Th. Units are liberated per cubic foot of the gas consumed. The heat so liberated expands the mixture of gas and air which remains after combustion, the expanding gases driving the piston violently forward. The combustion is so rapid that it has been termed an explosion, that being the term by which we are accustomed to describe similar operations when they occur in coal-mines, or in the house. We have at one instant a volume of gas and air which occupies a certain small space, and at the succeeding instant it tries to occupy a space very many times as great. In coal-mines and in the house when explosions take place, destruction follows. In the gas or oil engine the piston gives way, moving quickly to the front of the cylinder, and carrying the crankshaft round in the process. After the suction stroke comes the compression stroke. As the piston returns at the completion of the suction stroke, the gas and air inlet valves are closed, and the gaseous mixture, being confined within the cylinder, is gradually compressed, usually to something like 75 lbs. to the square inch. Compression, though not absolutely necessary with an internal combustion engine, is of great value, as it enables the charge of gas to be more completely burnt than would be possible without, and the higher pressures obtained enable a much larger power to be obtained from a given size of cylinder. The molecules of the gases are brought closer together, and this facilitates the passage of the heat necessary for the combustion of each individual molecule through the mass. At the commencement of the third stroke, the first out stroke of the piston, the mixture is ignited, and the explosion follows. The combustion of the gases is not absolutely instantaneous. It occupies a certain sensible period, measured by instruments that are very sensitive. The combustion of the gases is going on for a large portion of the out stroke, the active stroke of the engine; but the whole thing occupies so short a time that it appears to be instantaneous. The effect is, a certain number of heat units are liberated, according to the quantity and the composition of the gases, and a certain portion of the energy of the heat is delivered to the gaseous mixture remaining. On the commencement of the fourth stroke of the piston, the second return stroke, the exhaust valve is opened, and the products of combustion are forced out, giving rise to the coughing noise we are so familiar with where gas engines are working. The ignition of the gaseous mixture is accomplished in the most modern gas engines of small size by a hot tube, maintained at a high temperature by a small jet of gas, and exposed to the explosive mixture at the moment of ignition. There is a tendency, however, in the larger forms of gas engines to adopt the electrical ignition that is common with motor cars. The inlet and exhaust valves are worked by what is called the half-time

shaft, a second shaft driven generally by bevelled gear from the main crankshaft. The half-time shaft revolves once while the crankshaft revolves twice. On the half-time shaft are cams, which engage with levers, arranged to open the different valves at the right moment.

Governing the Internal Combustion Engine

The government of the engine is an important matter, and in two ways. The engine, as explained, receives its impulse once in every two revolutions. The energy then delivered has to be distributed over the remainder of the cycle. In addition to this, if the engine is to work economically, some provision is necessary to ensure the consumption of gas being approximately in proportion to the work being done. The first of these objects is accomplished by the flywheel. All gas engines carry one, and some carry two heavy flywheels on the ends of the crankshaft. The flywheels are proportioned to the energy delivered by the explosions; but in all cases they take up a sufficient portion of the energy of the explosion to enable the piston to perform its three strokes, during which it receives no impulse, and this notwithstanding the work the engine may be performing externally at the time. The result obtained is not an absolutely uniform speed, but an average uniform speed. If counted for any portion of a cycle, the speed will be found to vary considerably; but if the speed be taken for a minute, or for successive minutes, it will be found to be very constant. When the explosion takes place there is an acceleration of speed, and this is followed by a gradual slowing down till the next explosion occurs. This last feature is taken advantage of to govern the engine with reference to the load. The half-time shaft carries a hit-and-miss governor. It is constructed on the centrifugal principle, as with the steam-engine governor; but, in place of opening a valve more or less, as in the steam engine, it either opens the gas and air valves, or does not open them, according as a cam on the half-time shaft engages with a dog connected to the governor shaft, or does not. When the speed of the engine has fallen to a certain figure the two engage. Hence, if the load is light, the speed does not come down to the point, when more gas and air are admitted, until the engine has made four, six, or even eight revolutions, while, when the load is heavy, gas and air are taken in at every two. In some of the later forms of gas engine a mixing chamber is provided into which the gas and air are admitted, and from which they pass to the engine cylinder, under the control of a valve, which is opened more or less by a centrifugal governor.

Cooling the Engine Cylinder

The working of gas and steam engines differs in another matter—the temperature at which the cylinder walls are maintained. With steam engines, all heat lost through the cylinder walls is a loss of efficiency, and every effort is made to prevent radiation. With gas and oil engines, the heat taken from the cylinder walls is also loss, but it is necessary to enable the engine to continue working. The temperatures created by the explosions are very high, and a large portion of the heat liberated necessarily passes to the cylinder walls and thence to the castings, of which they form a part, and in which the valves are fixed. Hence, if the temperature of the mass of the casting is allowed to rise above a certain figure, the mixture of gas and air may be fired immediately it is admitted, and then the power obtained would be small. Hence arrangements are made to carry off a large portion of the heat, by causing a stream of water to circulate round the cylinder. The walls of the cylinder are cast with a hollow jacket, which sometimes extends to the back of the cylinder in which the valves are fixed. Tanks of water are provided, placed in any convenient position near the engine, and connected to the water jacket by pipes. Usually the heat delivered to the water in the jacket is sufficient to give the required circulation. The top of the water jacket is connected to the top of the water tanks, and the bottom of the water tanks to the underside of the jacket. The hotter water flows to the upper side of the jacket, and thence to the tanks, while the cooler water from the bottom of the tanks passes to the underside of the jacket. The circulation goes on as long as there is an appreciable difference between the temperatures of the water in the jacket and that in the tanks.' In hot climates trouble has arisen from the high temperature of the only water obtainable, but it has been overcome by increasing the quantity of water in the tanks. The tanks are generally made in the form of galvanized iron cylinders, holding a certain number of gallons as required. The number of cylinders required is also very easily calculated. The heat that is to be carried off by the water in the case of each gas or oil engine per minute is known. The initial temperature of the cooling water being known, and the temperature to which it may be raised before its cooling effect becomes too small to keep the engine running, a simple calculation will give the number of gallons of water required for any given working day, and the number of tanks. The cooling effect of the water may be assisted, where water is scarce, by passing it through cooling towers or equivalent apparatus, as explained on p. 146.



PLATE 7A.—Enclosing Ring, Field Magnet Coils, Pole Pieces, and Brush Gear of a Multipolar Continuous Current Generator, by the General Electric Co.

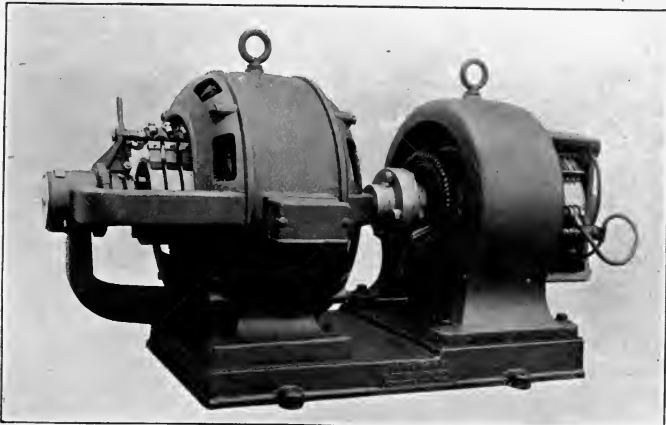
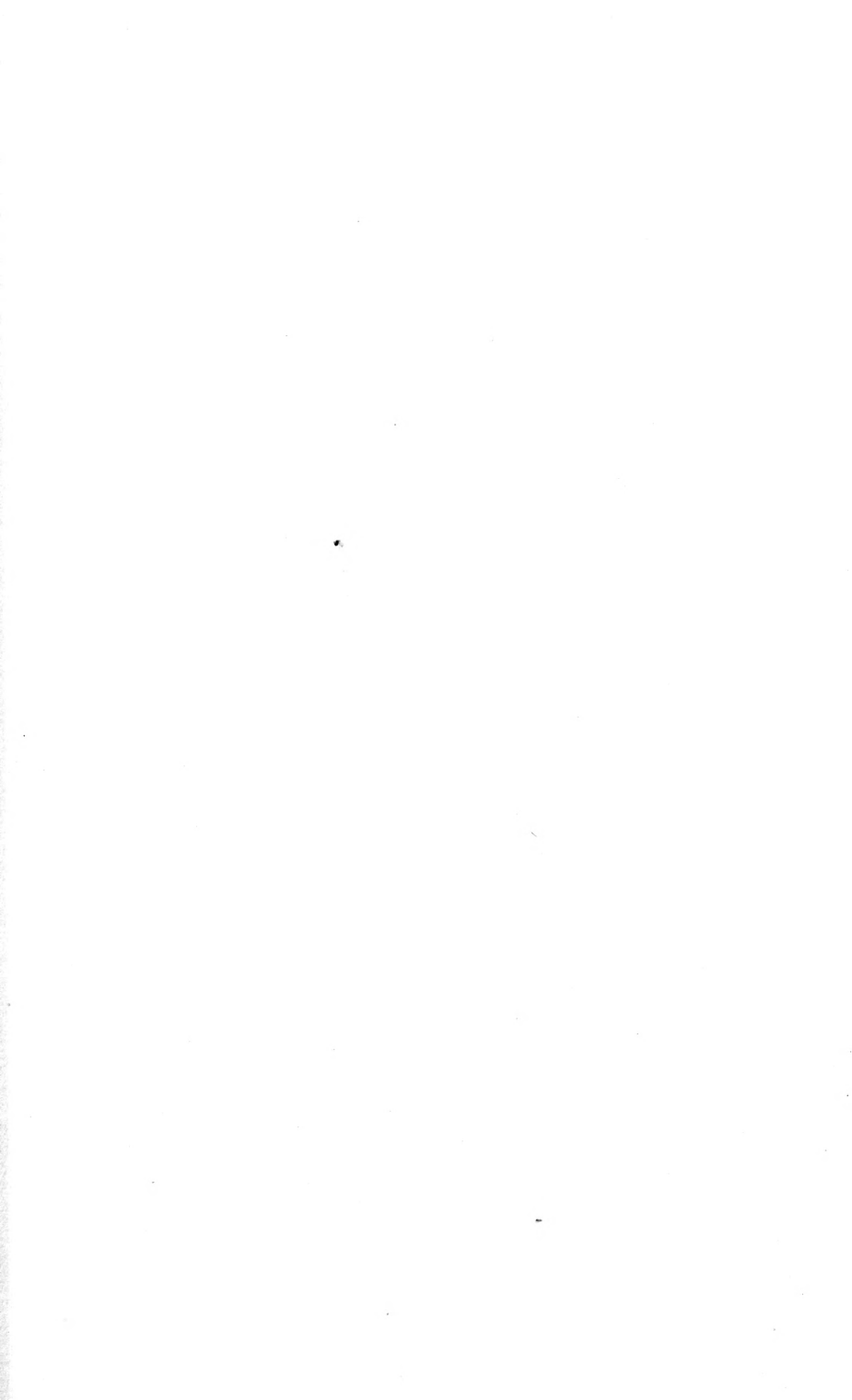

PLATE 7B.—Motor Generator made by Messrs. J. H. Holmes & Co. The Machine on the Left is a Three Phase Induction Motor, that on the Right a Continuous Current Generator.

[To face p. 160.]



Gas Engines for Large Powers

The Otto cycle, with one or more cylinders working together, can be employed for large powers, but the sizes of the engines tend to become large for powers such as those that have been named, 1000 H.P. and 2000 H.P., and so attempts have been made to bring the gas engine nearer the steam engine. These attempts have been made principally on the Continent of Europe, where the lead has been taken in the use of blast furnace gas for power. In one form of engine the Otto cycle is employed, but two cylinders are arranged tandem with their pistons on one rod, and delivering their power to one crank. The inlet and exhaust ports of the two cylinders are fixed in the ends of the cylinders farthest removed from each other, at opposite ends of the cylinder system, in fact.

The different parts of the cycle are going on oppositely in the two cylinders. Thus, calling the two cylinders A and B, when cylinder A is taking in gas, cylinder B is compressing, and when cylinder A is compressing, cylinder B takes an impulse. When cylinder B exhausts, cylinder A explodes, and so on. By arranging two pairs of cylinders, each pair tandem, on opposite sides of the flywheel, an impulse every stroke is obtained; and this method has been employed for driving electric alternate current generators that have to run together in synchronism, with considerable success. But an advance has been made upon this in the Körting and Oechelhausen and other engines, in which each cylinder is double-acting, while pairs of cylinders may be arranged tandem, and two pairs of tandems on opposite sides of the flywheel. In this form of engine, both cylinder ends are closed, as in a steam cylinder, the exhaust port being in the middle of the cylinder, and uncovered by the piston. Gas and air are taken in at each stroke, just as gas is in the double-acting compressor, the inlet valve being closed at a certain portion of the stroke, after which compression commences. The outstroke of the piston with this form of gas engine is the explosion stroke, the return stroke being both the charging stroke and the compression stroke. There is no suction stroke, the charging of the cylinders being performed by a pair of pumps, one for gas and the other for air. The pumps are so arranged that the gas and air are always admitted in the proper proportions, under a pressure of about 9 lbs. per square inch, and so that a scavenging current of air is driven into the cylinder after the exhaust gases have passed out, before the fresh charge of gas and air is admitted. The piston is made especially long. The cycle may be taken as follows: Commencing with the explosion at one end of the cylinder, the piston is driven forward to

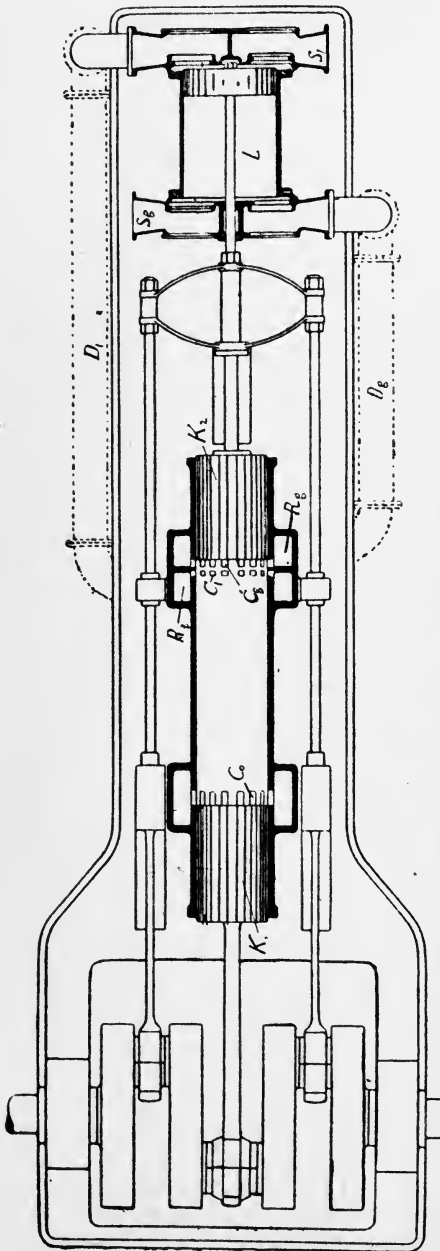

FIG. 79.—Horizontal Section of Oechelhausen Two-cycle Gas Engine.

the other end by the expansion of the burnt gases, inlet and compression proceeding at the other end of the piston. As the exhaust port is uncovered, the exhaust gases commence to escape. Then comes the current of air, clearing out the remaining products of combustion, and clearing the passages; then the inlet valve is opened for the admission of the fresh charge of gas and air, and meanwhile the charge at the other end has exploded, and the piston comes back, the exhaust having been closed in its passage. Then the inlet valve is closed, compression commences, continuing till the end of the stroke, ignition taking place at the commencement of the out stroke, and so on. In some engines an extra cylinder is added to the plant, the duty of which is to scour the working cylinders after the exhaust gases have escaped. The scavenging cylinder, as it is called, has its own piston worked from the crankshaft, which compresses air in the cylinder, the compressed air being turned into the working cylinders during the scavenging period. The Körtling gas engine is stated to use 92 cubic feet of gas, having a calorific value of 110 B.Th. Units per cubic foot per B.H.P. Fig. 79 shows a section of the

Oechelhausen gas engine ; Plate 5, an Oechelhausen gas engine driving a continuous current multipolar dynamo ; and Plate 6A shows a complete Körting gas engine.

Oil Engines

As already explained, the oil engine is really a gas engine. It burns a gas made from oil, and it is practically the same as the gas engine in every respect, except that provision has to be made for converting the oil into vapour. In the petrol engine, which is so much used in motor cars, and which is also an oil engine, the apparatus which converts the oil into vapour is called a "carburetter." In the stationary oil engine it is called a "vaporizer." There are two methods of vaporizing employed—the application of heat, causing the liquid to evaporate in the usual way, and spraying. In the latter method the oil is subjected to the action of compressed air or some equivalent arrangement, the oil being broken up into a fine spray. The object in both methods is to produce a fine state of division of the oil, so that it can mix with the air in the same manner as coal or producer gas does. In the modern oil engine the two methods—spraying and heating—are combined, the oil being sprayed into the vaporizer chamber, which is heated. In the petrol motor engine, the carburetter is a separate device, carburation taking place before the mixture of vapour and air enters the engine cylinder ; but in the stationary oil engine the "vaporizer" forms part of the engine itself—in many forms an extension of the engine cylinder. In Messrs. Hornsby's oil engine, the vaporizer is a chamber at the back of the cylinder, connected with the cylinder by a small passage. On the suction stroke of the engine, air only is drawn into the cylinder, oil being at the same time sprayed into the vaporizer. At a certain stage of the compression stroke the compressed air, having become heated to a certain temperature, is forced into the vaporizer chamber, where it meets the oil vapour, mixes with it, and the whole being at a sufficient temperature, the mixture ignites at the end of the compression stroke, the explosion following, as in the gas engine. In the Hornsby engine, the vaporizer is heated by the exhaust gases, which are made to pass out in its neighbourhood, and by the general heating of the engine body.

The spraying apparatus consists of what is called a needle valve, an arrangement something similar to a steam injector. It has a fine tube passing into the vaporizer chamber, the tube being partly filled with a fine needle the position of which can be regulated according to the kind of fuel and the rate at which vaporization is to go on. The vaporizer is also capable of alteration for

different kinds of fuel by altering a portion of the fittings. When starting, a charge of vapour is formed by the aid of a lamp provided for the purpose, fed with the same oil as the engine uses. The preliminary heating of the vaporizer chamber takes from seven to ten minutes, the chamber being heated to a dull red. The lamp is then turned off, and is not required again till the engine is restarted. The reservoir of oil is kept in the casting upon which the engine stands, and it is fed to the spraying nozzle by a small pump. In the National Gas Co.'s engine, which is very much on the lines of the Hornsby, the parts are nearly the same, except that an ignition tube is held in the rear end of the vaporizer chamber, and that a special device is added for conveying a jet of hot compressed air from the cylinder to the neighbourhood of the hot tube. The front of the vaporizer chamber is recessed, and the rear of the piston is cut away to fit the recess, so that when the compression stroke is complete, the piston enters this recess. Communicating with the rear end of the cylinder outside the recess is a small passage leading to the space in front of the ignition tube, and as the piston returns, the air is forced along this passage. On meeting the mixture of vapour and air in front of the tube, the temperature of the whole is raised sufficiently for explosion. In both the Hornsby and the National, and in all the engines worked on this method, the combustion—which is commenced at the rear end of the vaporizer—passes onward to the remainder of the compressed charge, liberating heat, and causing expansion of the products of combustion, as in the gas engine. In the Campbell and others the oil is carried in a tank above the cylinder, and runs by gravity into the vaporizer. In these forms the air drawn in on the suction stroke is made to spray the oil into the vaporizer, the latter being a hot chamber, whose walls immediately convert the finely divided oil particles into vapour, which mixes with the air which has formed it. From the vaporizer, in these forms, the mixture of vapour and air passes into the engine cylinder, where it is compressed in the usual way, and fired by a hot tube at the rear end, on the finish of the compression stroke. The ignition tube, in these forms, is sometimes heated by a lamp, and sometimes not, the provision of a lamp, in the case of the Campbell engine, being apparently a matter of precaution, as in one of the tests recorded it is stated that the lamp was not in use the greater part of the time. Broadly, it may be taken that a lamp is necessary with all oil engines using ignition tubes, for starting, in case of the tube cooling; but in all cases the whole mass of the engine becomes sufficiently hot, after running a short time, to keep the tube at the required temperature. The Campbell Co. have recently added to their apparatus the provision of a small jet of water, which enters the engine cylinder with the vapour and air, and they state that they obtain a further

economy in oil consumption by its use. The office of the cooling spray is to keep the engine cylinder cool by absorbing heat for its conversion into steam. The steam, when formed, also adds to the push given to the piston by its own expansion. The use of water in this manner is coming in in several cases.

Governing the Oil Engine

Several forms of oil engines are governed simply on the hit-and-miss principle, described in connection with gas engines, the supply of oil vapour being cut off when the speed of the engine exceeds a certain figure. This is largely the method employed with petrol engines used for motor cars. But in many forms of the stationary oil engine, an attempt has been made to obtain better government, and to proportion the consumption of oil to the engine, in accordance with the load, more on the lines of the steam engine. In some forms the governor controls the speed of the pump that feeds the oil to the vaporizer, lessening the supply with the increased speed, and *vice versâ*. In other forms, those in which the oil runs down by gravity to the vaporizer, the governor controls a graduated valve, through which the oil passes to the vaporizer, closing it partially when the speed increases, and *vice versâ*. In the Hornsby engine the pump continues to deliver the same quantity; but if the speed rises above a certain figure, the surplus oil is returned to the tank. In the Campbell engine the governor pushes down a steel catch when the speed exceeds a certain figure, preventing the exhaust valve closing. As this prevents the necessary lowered pressure being formed in the engine cylinder and its adjuncts, no air is sucked in, and therefore no oil passes into the vaporizer. It will be understood that in some of these patterns, those in which the oil runs down by gravity, the passage of the air is necessary to bring the oil into the vaporizer. There is an injector action in connection with the air and the oil, the passage of the air in front of the tube drawing the oil out into the passage leading to the vaporizer. The action is similar to that of the scent spray, and it operates very frequently in ventilation.

The Ignition Problem

With petrol motor-car engines ignition has settled down completely to the electric spark, and this appears to be preferred also by a few makers of stationary oil engines; but the great majority prefer the ignition tube. The reason given by one maker is, the

platinum points between which the ignition spark passes become clogged with a mass of carbon, which prevents the passage of the spark. There is a great deal of truth in this. In petrol motor-car engines there is some trouble from this cause, and petrol is much less liable to deposit carbon than the heavier oils that are used in stationary engines. The arrangement for ignition by the electric spark is as follows. Some form of terminal piece is fixed in the cylinder or vaporizer, where it is desired that combustion shall commence. There are two forms of sparking arrangements. The most common consists of a porcelain plug, fixed in a screwed metal fitting, which is screwed into the cylinder. The plug carries at its inner end two small platinum wires, insulated from each other, placed with their ends at such a distance apart that the spark, a "fat spark," will pass easily across. The current for this, which is at a pressure of several thousands of volts, is provided by a battery of accumulators, or dry cells, and an induction coil. Dry cells are going out rapidly for motor-car work, as they are so uncertain; while for stationary work, where it is not convenient to charge accumulators, bichromate cells may be used. The apparatus is completed by what is called the commutator, which usually consists of a disc of insulating material, carrying contact pieces, either on its edge or on its face near the edge, with a contact held by a spring pressing against the disc. The disc is revolved by the half-time shaft, and when one of its contact pieces comes opposite the stationary contact piece, the circuit is closed, and is broken immediately afterwards, as the disc moves on, a spark then passing between the points in the cylinder, the commutator arranging that the spark passes at the time it is required to explode the charge. With the other method, known as the magneto, a small magneto-electric machine takes the place of the battery and induction coil; its armature, which is made on various patterns, being operated by gearing from the half-time shaft. There is no commutator, but in its place the half-time shaft works a rod which breaks a contact inside the cylinder.

The Diesel Engine

The Diesel is also an oil engine, but on very novel lines. There is no ignition tube nor equivalent device, the ignition being accomplished by the heat generated in the air, which is compressed in the cylinder for the purpose, and which combines with the oil vapour. In the Diesel engine there are practically three operations going on. Air, only without any vapour, is sucked into the cylinder on the suction stroke—the Diesel engine works on the Otto cycle—and is

compressed on the return stroke to a pressure of 500 lbs. per square inch, giving a temperature of approximately 1000° Fahr. At the same time, the engine is driving a two-stage air compressor by gearing from its crankshaft, supplying compressed air to a reservoir, which is maintained at from 750 lbs. to 800 lbs. pressure. At the moment when ignition takes place in the ordinary type of gas and oil engine, a very finely divided spray of oil is injected into the

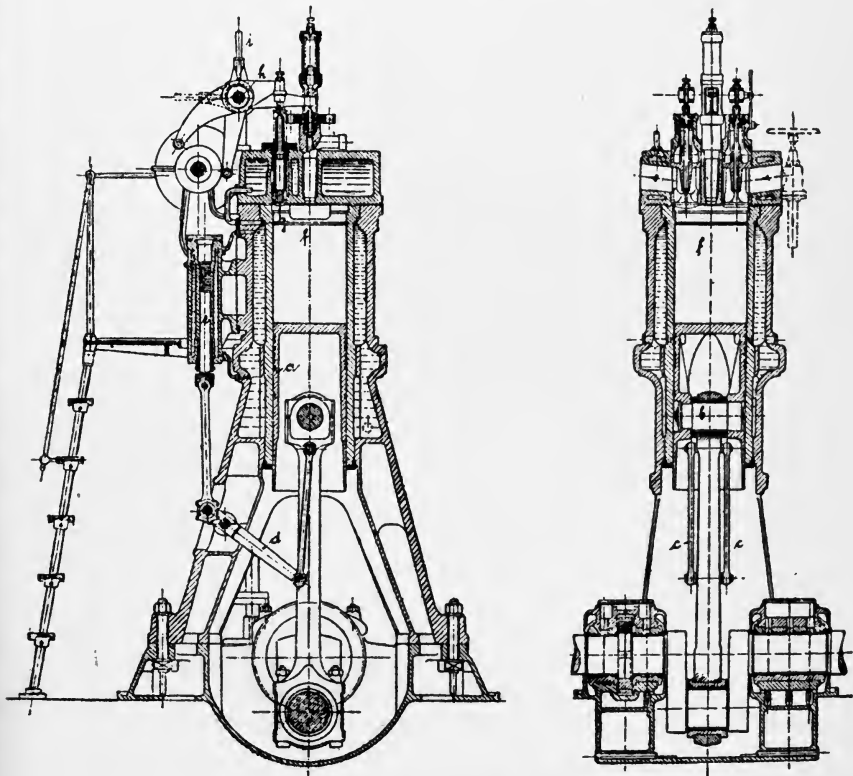

FIG. 80.—Sections of Diesel Oil Engine.

cylinder, and sprayed by means of the compressed air in the reservoir. The oil spray, meeting the air in the cylinder at the high temperature mentioned, burns, the oxygen necessary for its combustion being provided by the air which ignites it. The oil is said to burn steadily, the effect being more like that of steam entering a steam engine than the explosive force of the gas and oil engines described. The oil is forced into the cylinder by means of a pump, as in some of the

other oil engines, the compressed air assisting it to drive it in, and atomizing it in the process. The remainder of the cycle is the same as with other oil engines. Any kind of oil may be used in the Diesel engine, but the cheaper kinds, the crude heavy carbon oils, are preferred, because they are cheaper and richer in carbon. The cost for fuel, when the crude oils are employed, is claimed to be less than that of any other oil engine. The quantity per B.H.P. is rather less than half a pint, while the cost of the crude substance is much less than the oil sold for illuminating purposes. The crude oil is the refuse after all the refined oils have been distilled off. The fuel cost, using this substance, is stated to be about one-tenth of a penny per B.H.P. The Diesel engine is governed by controlling the pump supplying oil to the cylinder.

The Diesel Co. claims, however, that they obtain a government much nearer the load than is possible with the usual type of oil engine, inasmuch as the quantity of oil allowed to enter the cylinder is arranged at the very last minute, just before combustion commences, and they show, by the aid of indicator diagrams, that the effect produced, when the engine is working at less than full load, is very similar to that in a steam engine whose governor controls the slide cut-off. In fact, as mentioned above, the Diesel engine approaches very closely in its working stroke to the steam engine. Fig. 80 shows sections of one form of the Diesel engine.

A Coal-dust Burning Engine on Similar Lines to the Diesel

It will be of interest to mention that attempts have been made to work engines on the same principle as the Diesel oil engine, with coal dust as a fuel. Coal dust is being introduced for firing steam boilers, on the same lines as oil fuel, and it is a natural extension of the principle to work internal combustion engines with the same fuel. At the Glasgow Exhibition of 1901 an engine was exhibited, though the writer believes it was not actually run in the exhibition, of 150 H.P., in which coal dust was the fuel. The coal dust was injected into the cylinder in the same manner as the vapour of oil in the Diesel engine, the charge being ignited by the heated air, which had previously been compressed in the same manner as in the Diesel engine. The engine, the writer believes, worked on the Otto cycle. The air for the engine was warmed before passing into the cylinder by passing over parts of the engine which were at a high temperature. The engine has not been placed on the market. Possibly difficulties arose in connection with its working when in service that had not disclosed themselves in the experimental stage; but there would

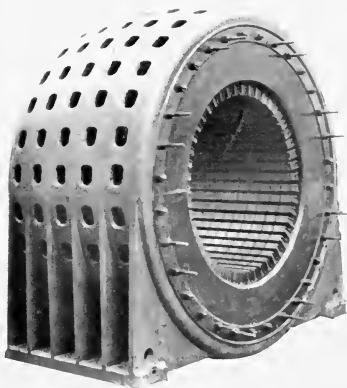

PLATE 8A.—Armature of Three Phase Generator for Turbo Driving ready for the Coils, made by Dick, Kerr & Co.



PLATE 8B.—Armature of Three Phase Generator for Turbo Driving, with Coils complete, made by Dick, Kerr & Co.



PLATE 8C.—Revolving Field Magnets of Three Phase Alternator for Direct Driving from a Steam Turbine, made by Messrs. Dick, Kerr & Co. The Rings shown on the Axle are to deliver the Current to the Field Coils.

appear to be no reason, other than practical ones, for its non-success. Every one who has visited a colliery where screening is going on is familiar with the cloud of finely divided particles present in the air, and it is these that are made to ignite in the engine cylinder, mixing with the air necessary for combustion, in the same way as the vapour of oil does.

Having decided on the source of power, the engines to be used for driving the dynamos, the next items in the generating station are the—

Generators of Electricity

Two forms of generators of electricity are now employed in mining work, for continuous current and for three-phase alternating current. Single-phase alternating current is not yet suitable for mining work, because the single-phase motor is not yet a practical machine such as could be employed for driving mining machinery. The two-phase generator is almost the same as the three-phase generator. The principle upon which continuous current and alternating current generators are based is the same. When a conductor is moved through a magnetic field, or when the strength of the magnetic field in which a conductor is lying is changed, or when any equivalent of this is produced, an electric pressure is created in the conductor, proportional to the strength of the magnetic field, and to the rate at which the change, in its bearing upon the conductor, takes place. Put in another form, assuming the conductor to be in the form of a loop, as all conductors used for generating current are, the pressure created depends directly upon the rate of change of the number of lines of force passing through the loop. In practical dynamo machines there are a number of loops of conductors, and they are held sometimes in slots on the peripheries of drums built up of thin iron or steel plates, sometimes in slots in discs held on the inside of iron or steel cylinders. In both cases it is arranged that a powerful magnetic field is created within a small annular space between an outer cylinder and an inner one. In continuous current machines the usual arrangement is, there is an outer cylinder of iron or steel having feet for fixing to foundations, or forming part of a bedplate which performs the same office. Held on the inside of the cylinder, and pointing radially inwards, are cores of electro-magnets, the cores being sometimes of wrought iron or mild steel, forming part of and cast with the containing cylinder, sometimes built up of thin iron plates cast into the steel or iron cylinders, when the latter is cast, and sometimes of other arrangements. The magnetic field in the polar space on the inside of the cores of the field magnets is created by currents passing in coils of wire round

the radial cores described above. In modern machines the field-magnet coils are wound sometimes on wood spools, sometimes on metal spools, and sometimes are simply made up into coils. In either case they are very carefully insulated, the wires of which the coils are composed having all the moisture extracted from their cotton coverings, in a vacuum oven, and being afterwards steeped in an insulating varnish which resists moisture and heat, and then wrapped with insulating tapes, and in other ways protected from mechanical injury, damp, etc. It is a common practice to utilize the crescent-shaped ends of the cores of the field magnets to hold the field coils in position. Where the field magnet cores are cast in the containing ring, the formed coils are slipped over them, and the pole pieces are then fixed outside of the field coils, and bolted to the cores. The crescent-shaped pole pieces form an inner cylinder broken by the gaps between them. Plate 6B shows a complete multipolar continuous current generator, made by Messrs. Mather & Platt.

The Armature

In the continuous current machine **the armature**, on which the wires that are to perform the office of generating the current are carried, is built up of very thin iron or steel plates. In the smaller machines the plates are in the form of complete discs. In the larger machines they are in the form of sectors of discs, there being as many sectors as there are pairs of poles in the machine. In both cases the peripheries of the plates are slotted, the inner edges are punched or slotted, and the plates are built up upon brass spiders, themselves made in sections in multipolar machines, the whole being held upon a brass boss in the centre, through which the driving axle of the machine passes, and to which it is keyed. The peripheral slots on the plates, when the latter are in position, form longitudinal channels in which the copper conductors lie. Before building into the drums the iron plates form, they are first varnished. The modern plan is, the plates pass through varnishing machines consisting of rollers over which varnish drips, the varnish being spread out over each plate in a thin layer. The plate is then carried on to a drying apparatus, drying being accomplished by hot air, and the plate emerging at the opposite end of the machine, after a few minutes, with a dry adherent coating of varnish on each side. In some machines a very thin sheet of paper is placed between the plates. In all large machines, also, air ducts are provided at certain portions of the lengths of the drum by fixing distance pieces between successive sections of plates, the air passing through the centre of the drum, and out at the periphery through the spaces left between the plates. When the plates are assembled on

their spiders, they are squeezed together by hydraulic pressure, and retained in position by massive iron end discs. The conductors for continuous current machines are almost invariably what is called "former wound." The coil is made on a wooden former of the exact shape the coil will take when it is in position on the armature. After being formed it is dried in the vacuum oven, varnished, the varnish set by heat in the oven, and it is then protected by insulating tapes, which are also dried and varnished, the varnish being dried by heat, the ends of the coil being left out in the positions they are to occupy. The coils are carefully tested before being placed in the machine, for resistance, each coil being exactly like all the others on the same machine. The longitudinal channels on the armature are carefully milled out, all pin points, iron dust, etc., removed, and the channels themselves are lined sometimes with mica built into the form of the channel, sometimes with micanite, a substance formed by building the thin shreds of mica into a flexible cloth or sheet, and sometimes with other substances, such as presspahn. It will be understood that the possibility of a connection between the coil and the iron in which it lies, is the weak point of the armature, the one that gives the greatest amount of trouble in maintenance, and therefore it is the one over which most care is taken. If the insulation is not properly carried out, if at any point a minute pin point of iron has been left in the slot, even if some non-metallic dust has been left, the vibration of the machine may gradually cause the lessening of the thickness of the insulation between the copper conductors and the iron, with the result that sparking may occur at that point, when some heavy load is taken off the service, induction being particularly heavy on those occasions, and pressures many times greater than that of the service itself being often present. If a spark does pass, the machine is wrecked. In the modern machine it is fair to say that breakdowns of that kind are comparatively rare. In the machine of twenty years ago they were only too frequent.

The cylindrical polar space in which the armature revolves may have only one magnetic field, being then known as a bi-polar, or two-pole machine; but more frequently in modern continuous current dynamos there are two or more magnetic fields, with four or more magnet poles, and it is then known as a multipolar machine.

The two-pole machine has almost died out. It was, however, the form in which all the early machines were constructed. In the latest form of the bi-polar machine the electro-magnets consist of two slabs of iron or special magnet steel, rising from a base plate with which they are cast, where the special magnet steel is employed, the base plate being long enough to accommodate the pedestals to which the bearings are fixed, in which the armature axle runs. The two slabs of iron are placed at sufficient distance apart to allow of the spools carrying

the magnetizing coils being slipped over them, and their upper ends are bored out to form the polar space mentioned. In the Parker two-pole machine, which is the latest survival of the type, the pole pieces are hinged on a horizontal line at about the middle of the diameter of the space occupied by the armature, so that the upper portions of the pole pieces can be thrown back, and the armature lifted out vertically, with the smallest chance of damage.

In the multipolar dynamo, the bearings for the armature axle are carried, almost invariably, on pedestals rising from the bedplate to which the enclosing field magnet ring is secured; and it is arranged, in some of the larger sizes, to run the enclosing ring back, clear of the armature, upon an extension of the bedplate, the armature coils then being easily got at for repairs.

The Winding of Continuous Current Armature Coils.—There have been two forms of winding of the coils of continuous current armatures, known respectively as ring winding, the armature being known as the ring armature; and drum winding, the armature being known as the drum armature. The two forms of armature and the two windings are taken from the two early machines, the Gramme and the Siemens. The ring armature has practically died out. Its construction was as follows. In the very early machines a ring of iron wire was formed by winding purest charcoal wire on a former, the ring forming a hollow cylinder, which was wrapped with calico. Cotton-covered copper wire was then wound transversely across the outside and through the inside of the ring, the whole being held on a wooden hub driven into the space left inside the copper wires on the inside of the ring, the commutator, which was built up very much as in the modern dynamo, though not as well insulated, was soldered to the ends of the wires, and the axle of the machine was slipped through a hole and keyway in the wooden hub, and through the centre of the insulating rings of the commutator, the whole being tightened up by a couple of iron nuts pressing against the end of the commutator, the back end of the armature hub butting against a flange provided for it on the axle. Later, the iron wire ring gave place to a ring built up of thin iron plates, with paper between, or insulated by varnish, the plates being held on a brass spider which was keyed on the driving axle, the wires being wound as before over the outside of the iron, which had been insulated in various ways, and through the space left on the inside between the spider arms and the core. The drum armature consisted originally of a long cylinder of iron wire wound very much in the same manner as the Gramme core, but from three to four times as long, and from the first the copper wires were only wound upon the outside of the iron core, this having been insulated in a similar manner to the core of the Gramme ring, and being held on a wooden hub driven into the middle. In

the drum armature the coils of the copper wires crossed each other, both at the commutator end and at the back of the armature, and in the early forms there were always two layers of wire. As each coil occupied a certain portion of the circumference at opposite ends of a diameter, when a certain number of coils had been wound, the armature was completely covered, but there were only half the coils on that were required, so a second layer was put on, commencing at the opposite side of the armature to that at which the first layer commenced, and a second lot of coils were wound over the first, insulation being placed between the two layers and between the wires, where they crossed at the back and in front of the armature. It was necessary in this form of winding to allow a large space, both at the back and the front, so that the ends of the coils which came out to the commutator were very much longer than those in the Gramme ring. In both the Gramme ring and the early Siemens' machine successive coils were connected together in series, the end of No. 1 coil being connected to the commencement of No. 2, the end of No. 2 to the commencement of No. 3, and so on. In the Siemens' armature with two layers, the under layer formed the coils connected to one half of the commutator, while the layer on top formed the coils connected to the opposite half of the commutator. This construction has also disappeared. There were frequent troubles with that form of winding from the breakdown of the insulation between the wires which crossed each other at the back and front of the armature. Wires between which a large portion of the total pressure generated by the machines existed were often very close together, and the insulation would gradually break down, sparking between the wires resulting, and coils, or portions of them, burning. In both the early Siemens' and the Gramme ring armatures there were also troubles only too frequently, from the breakdown of the insulation between the coils and the iron core, this leading, as will be explained in Chapter VII., to burning out of some of the armature coils. The next step in the drum armature was, only one layer was wound, and each alternate coil was connected to the opposite brush. There were only two sets of brushes to the early machines. This arrangement meant that the full pressure generated by the machine existed between the adjacent coils, and this, again, in the early days of generator construction, led to sparking between adjacent coils and to the burning of portions of the armature. Modern practice has settled down to one form of armature, the drum, to one construction of core, that which has been described, the slotted; but there are two forms of windings, known as the wave and lap winding, for the arrangement of which the reader is referred to the text-books specially devoted to the subject. In both forms it is arranged that a certain number of coils are always delivering a positive current to the positive brushes, and certain other coils are at the same time

receiving an equal negative current through the negative brushes. In all continuous current machines the coils on the armature form one continuous loop, as if wound from one length of wire, the ends of certain coils being connected together to form the continuous ring, and these junctions connected to segments of the commutator.

The Commutator

The commutator is, perhaps, the most important point of the continuous current machine. It is certainly the one which gives the greatest amount of trouble. It is a hollow cylinder built up of a number of segments of copper, separated from each other by plates of mica, the whole being held together by rings of micanite, held by iron rings upon a boss carried by the driving axle of the armature. The copper segments are made from hard-drawn pure copper. Purity of the copper is of the highest importance. In some machines the copper segments are cast or drop forged, but are always of the very purest copper. There is a difficulty in casting copper pure and hard, but it is an advantage to have the segments cast in the form in which they are to be assembled in the commutator. One of the difficulties in the construction of a commutator, especially those of the large multipolar machines now in use, is the holding the commutator together after it is built up, in such a manner that it will withstand the twisting strains brought against it as the armature revolves. To meet this difficulty the segments are recessed in the lower portions in various forms, the recesses, when the segments are built into a cylinder, forming the channels in which micanite rings are fixed. The difficulty of the problem is, giving the whole structure sufficient mechanical strength, while maintaining the perfect insulation of each individual segment from its neighbour, and of the whole of them from the axle or the boss upon which they are built up. In early machines wood rings were employed for insulation, held in channels recessed in the ends of the segments. The wood rings frequently split, and the coil nearest the split then burned. Later, vulcanized fibre and vulcanite were employed, but these also were not satisfactory. Vulcanite is very liable to split, and vulcanized fibre did not give good mechanical strength, in the form of the rings that were turned for the purpose. Modern practice has adopted the substance known as micanite. Mica is a very peculiar substance. It has a very high insulation resistance, and it also, which is more important, resists sparking through it very much better than almost any known substance. But it exists only in plates made up of very thin laminae. You can have a mica plate as thin or as thick as you like, but its two sides will always be parallel, and it will split longitudinally as much as you

please. In micanite the mica is reduced to its chips, the chips being in the form of very small laminæ, and these are made into a sort of paste by the aid of one of the insulating varnishes that have been introduced during recent years, which withstand moisture and heat, and the whole is moulded into the form of rings, formed under hydraulic pressure. By this means strong rings have been produced, having very high insulating qualities, and comparatively great

mechanical strength, the result being that one of the serious troubles in connection with commutator building has been practically got rid of. Each commutator segment has an arm attached to it, standing radially out from it, and to this arm the ends of the coils of the armature forming the junctions mentioned above are secured. The arm is sometimes cast with the commutator segment, but is more frequently secured to it by screws and solder. The armature wires are secured to the commutator arms in the smaller machines by soldering, the arms being well tinned, and the ends of the wires being also well tinned. With

large machines the wires are held in crutches formed in the commutator arms by screws, and the whole mass is also sweated up together with solder. Holding the ends of the pairs of wires firmly connected to their proper commutator segment and to each other is another of the troublesome problems of dynamo construction. It is referred to again in Chapter VII. Fig. 81 shows a commutator built up, ready for its insulating rings.

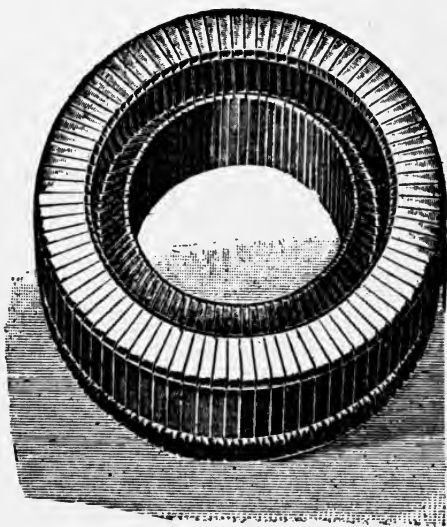

Fig. 81.—Showing a Commutator built up ready for the Insulating Rings, the Recess for one of which is shown in Front. The Lugs for the Armature Wires are seen at the Back.

The Excitation of Continuous Current Machines

The continuous current machine is self-exciting, or it may be excited, by the current from another machine, as convenient. As explained in Chapter I., all iron that has once been subjected to a

magnetizing electric current, unless the magnetizing current only produced magnetism on the unstable portion of the magnetizing curve, retains a small quantity of magnetism, after the magnetizing current has ceased, and this small amount of magnetism is sufficient to create a small current in the armature coil when the machine is run. This small current, being passed through the coils of the field magnets, increases the magnetism created in them slightly, the increased magnetism giving rise to increased current in the armature coils, this again increasing the magnetism, and so on, until the full

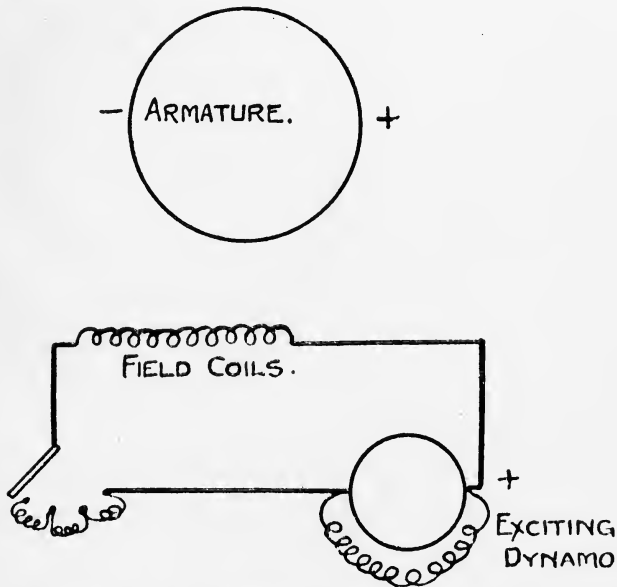

FIG. 82.—Diagram of Connections of Separately Excited Generator with Adjustable Rheostat in the Circuit of the Field Coils. + and - are the Positions of the Brushes.

magnetic field is created, and the full pressure is generated, for which the machine is designed. This is the action which takes place. In practice it occupies only a very short interval of time, and its existence is only known when from any cause a machine fails to "build up," as it is termed. In large generating stations it is frequently arranged, even where continuous current machines are employed, to run a separate generator for the current required by the field magnets. The connections for this are shown, for a single machine, in Fig. 82. Continuous current generators may, however, be self-excited on either the series, shunt, or compound arrangement.

In series-wound machines the coils of the field magnet are wound with thick wire, sufficiently large to take the whole current generated by the machine. In the case of multipolar machines, it may be arranged that the current is split up between the pairs of field magnets in parallel, or it may go round the whole of them in series. Fig. 83 is a diagram of the connections of a series-wound machine. Very few series-wound generators are now made, because the shunt-wound and the compound-wound answer all purposes very much better. The series-wound machine reflects every change in the external resistance of the circuit, in a sense which is against the efficient working of the apparatus. Thus, supposing a machine to be running at a certain speed, furnishing a certain current, with a certain pressure between its terminals. If the resistance of the outer circuit through which the current is passing increases, the current passing through the whole circuit, including the coils of the field

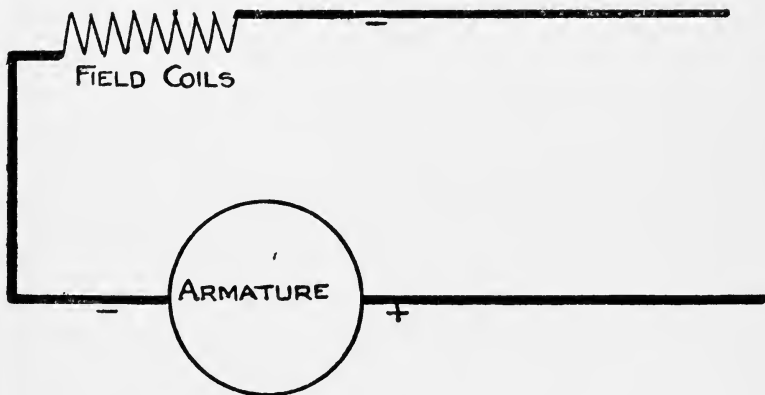

FIG. 83.—Diagram of Series-wound Generator. One End of the Field Coils is connected to one Brush, usually the Negative, the other Brush and the other End of the Field Coils forming the Terminals.

magnet and the armature, is reduced, and this means that the load upon the driving engine, whatever it may be, is also reduced, with the result that usually, unless the engine is exceedingly well governed, it increases its speed, and a current is produced in the outer circuit, that is not required. On the other hand, if the resistance of the outer circuit decreases, the increased current passing brings an additional load upon the engine, which tends to slow up. The most striking instance of this is the case of one or two arc lamps worked by current from a series machine. If the lamps burn long arcs, the engine will increase its speed, and if one of them, as nearly always happens, goes out, its carbons coming into contact, the

engine is pulled up. The series-wound generator is suitable for running a number of arcs in series, and it is employed in America for this purpose, but in the special form well known in this country some years ago, of the Brush arc-lighting machine. In America they run as many as 130 lamps from a single Brush machine in two sets of 65 lamps each. For mining work, however, it is much more satisfactory, and generally much more convenient, to take current from the service, by one of the methods that have been described in Chapter III. If any mine manager, however, has a series-wound machine, and wishes to run some arc lamps from it, he can do so, providing that he arranges cutouts to his lamps in case they go out. Perhaps the most important part of the Brush arc-lighting system was the arrangement by which the pressure was reduced in case a lamp went out, or whenever the resistance of the circuit was decreased. The series-wound generator may also be used for furnishing current to drive a series-wound motor where it is convenient for other reasons; but again, it will be far more satisfactory to take current from the supply service.

The Shunt-wound Generator.—In the shunt-wound generator the field magnet coils are energized by only a small portion of the

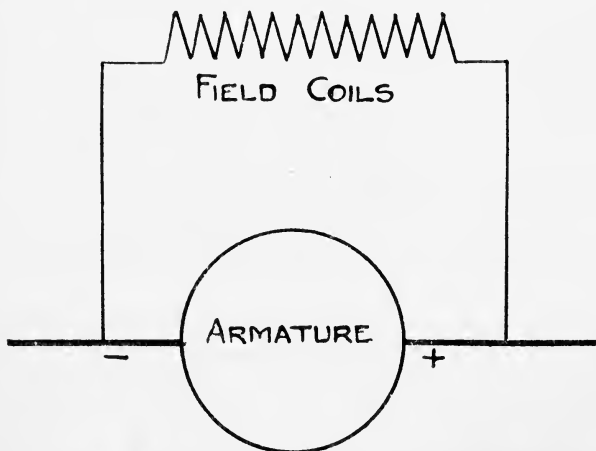

FIG. 84.—Diagram of the Connections of the Shunt-wound Generator. + and - are the Brushes. The Ends of the Field Coils are connected to the Brushes.

current generated by the armatures. The field magnet coils are wound with fine wire, to a resistance such that only a small fraction of the armature current passes through them, and the ends of the field magnet coils are connected to the brushes, which form the

terminals of the machine, and to which the cables from the outer circuit are also connected, or to terminals fixed on the machine, having leads connecting them to the brushes. Fig. 84 shows the arrangement of the connections of the shunt machine. When no current is taken by the external circuit, the only current passing through the armature of the shunt-wound generator when the machine is running, and is fully excited, is the small current passing through the field coils, so that the pressure between the brushes is very nearly equal to the total pressure generated by the armature.

It will be remembered that every resistance makes a charge upon the pressure delivered to it, for the passage of a current through it, the charge being measured by the formula $E = CR$, where E is the charge upon the pressure, C is the current passing, and R is the resistance. As the current passing into the outer circuit increases, and therefore the current through the armature also increases, the charge made upon the pressure created by the armature coils increases, and the pressure between the brushes decreases. This causes the current passing in the field coils to decrease, the strength of the magnetic field in which the armature coils are moving to decrease, and reduces the pressure created by the armature coils, this reducing the pressure at the brushes, and still further reducing the strength of the current in the field coils, and so on.

If the external resistance is steadily decreased so that more and more current passes in the outer circuit, the pressure generated by the machine is also steadily decreased, until a critical point is reached, when, if an attempt is made to pass more current into the outer circuit by still further lowering the resistance, both pressure and current fall, and when the terminals of the machine are short-circuited, when there is no resistance between them, the machine generates no

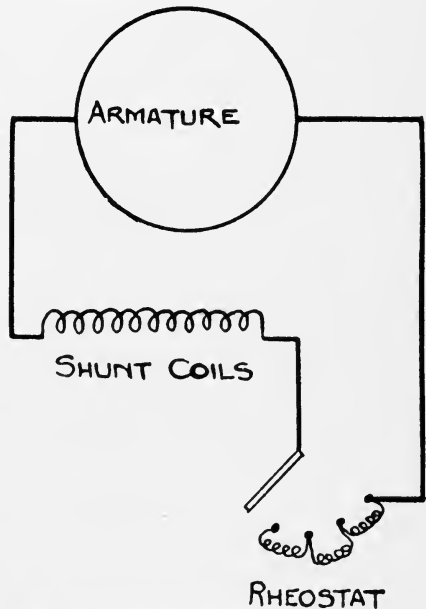

FIG. 85.—Diagram of Shunt-wound Generator with Adjustable Rheostat in the Circuit of the Field Coils. The Arrangement enables the Pressure to be kept Constant, with Constant Speed and Varying Current in the External Circuit, or both to be Varied at Will.

pressure and no current. It will be understood that increased current is taken from any machine by lowering the resistance of the external circuit—say by switching on a larger number of parallel circuits, such as lamps or motors. It will be seen also that the variation of the pressure at the terminals of the shunt-wound motor is inversely as the resistance of the armature coils. If it were possible to build the armature of a shunt-wound generator with no resistance, the pressure at its terminals would be constant, and the lower the resistance of the armature coils, the smaller is the variation of the pressure at its terminals, because the charge upon the pressure generated is smaller. In all shunt-wound generators there is a certain range of current, over which the variation in pressure is small. Electrical engineers express the fact by saying that the machine has a flat curve up to a certain point. Fig. 85 shows the connections, with a shunt-wound generator, for regulating the current in the field coils by an adjustable resistance, enabling the speed to be maintained constant.

The Compound-wound Generator.—The compound-wound machine is a combination of the shunt-wound and series-wound

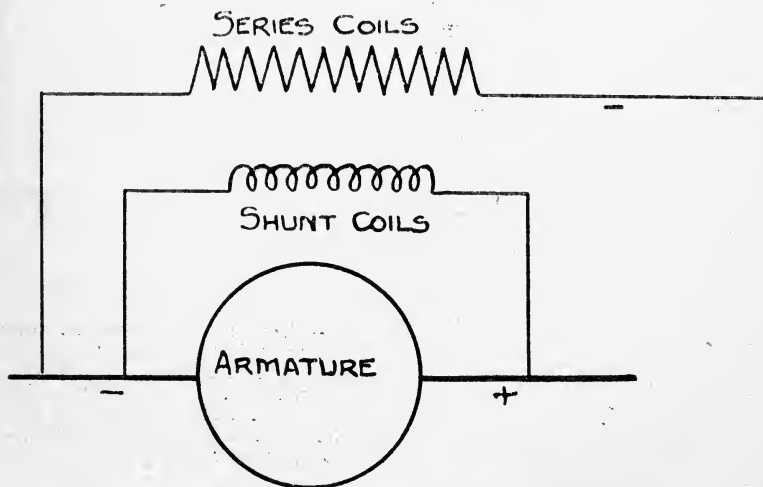

FIG. 86.—Diagram of the Connections of a Compound-wound Generator. The Ends of the Shunt Coils are connected to the Brushes, and one End of the Series Coil to one Brush, usually the Negative.

machines, or as the author prefers to express it, it is the shunt-wound machine with a few turns of series winding on its field magnets, sufficient to make up the loss in pressure due to the charge made by the resistance of the armature for the passage of the current

through it. The series coils create electro-magnetism in the same manner as the shunt coils, and as if they were independently exciting the machine. That is to say, they increase the strength of the magnetic field, thereby increasing the pressure generated by the armature coils, and they must be of sufficient number to create sufficient increased magnetism to provide the additional pressure required to make good the charge for the armature coils, and also the charge for passing through the series coils themselves, the current from the external circuit being taken from one brush and the end of the series coils, as shown in Fig. 86. The characteristic curve of the compound-wound continuous current generator is a straight line within the limits of the machine. The machine, however, may be constructed, if desired, and often is, to "compound up," as it is termed. The series coils are made a little longer than is necessary to give the additional pressure for the charge made by the armature and field coils themselves, and this provides a pressure which slightly increases, in any ratio that may be desired, as the current taken from the machine increases. It is used for delivering a constant pressure with varying current at any point selected at a distance from the machine. Thus the pressure at the pit bottom, or at a distributing point in-by, may be constant. It must be understood, however, that when the machine is arranged to "compound up," the pressure at its terminals, and at any points between its terminals and the point of constant pressure, varies with the current, so that if a supply of current for lamps is taken from the terminals of the machine with this arrangement, the lamps will be subject to a varying, and sometimes dangerous pressure, unless some provision is made to neutralize the increased pressure as the current increases. This, however, is easily done if it is worth while for other reasons. A switch may be inserted in the circuit, with an adjustable resistance which is thrown in or taken out as the current increases or falls in the main circuit, and the switch may be worked by a solenoid whose coils are connected in the main circuit, or a branch of it that varies in the same proportion.

Brushes and Brush Gear and Connections of Armature Coils.—In the two-pole machine the whole of the connections are very simple. There are only two sets of brushes placed at opposite ends of a diameter of the commutator, and the current is taken directly from the brushes to the field coils, or otherwise. With multipolar machines, however, a different construction is necessary. With four-pole machines, current is being delivered in two quadrants of the armature in the same direction, and in the other two quadrants in the opposite direction, and it is therefore necessary to collect the current at four points instead of two. With six-pole machines it must be collected at six points, and with eight-pole machines at eight

points. In the early multipolar machines the coils that were generating current in the same direction at the same time, were connected together by wires carried round between the commutator and the front of the armature, and only two sets of brushes were employed, these being fixed in the four-pole machines 90° apart. In the modern dynamo, however, there are brushes for each point of collection, the brushes being either carbon blocks or copper, made up as will be described, in either case held in shoes of various forms, the shoes being fixed mechanically to spindles parallel with the commutator, and held by, but insulated from, usually a massive iron ring, supported on the bearing at the armature end, or by brackets on the enclosing ring of the field magnets, as shown in Plate 7A. The current from the commutator is delivered to the brushes, from them to the spindles which hold them, and these spindles are connected, by conductors of sufficient size to eliminate resistance, with the spindles of the other brushes which are delivering current in the same direction. Practically a multipolar machine consists of a number of machines, held together by the enclosing ring, each machine consisting of two adjacent magnet cores and their windings, the piece of the enclosing magnet cylinder behind them, and the piece of the armature core in front of them, and the current generated by each machine is delivered to its own set of brushes, and thence to one set of terminals by the brushes being connected in parallel. In addition, in many forms of continuous current machines now made, there are equalizing conductors, connecting points on the commutator together, at which the pressure should be the same at each instant, the idea being to equalize the generation of current all round the machine. The current from the different brush holders are brought to massive terminals fixed on insulating blocks upon any convenient part of the machine.

Carbon and Copper Brushes.—Carbon brushes, as they are termed, though they are blocks of carbon, are employed very much more frequently in modern machines than copper brushes. The name arises from the fact that the early arrangement for collecting the current from the commutator was a brush, made of a number of copper wires soldered together at one end, and held so that the loose ends bore upon the commutator. Copper brushes are still employed, and are very much preferred by some engineers, but the simple form described above has been very much departed from. One form of copper brush made by the Wirt Co. consists of leaves of thin copper, and of a comparatively high resistance metal, placed alternately one above the other, one end of the laminated mass resting on the commutator, and the other being soldered together. Carbon brushes are of various forms and various sections. A favourite form is, a block having a rectangular section where it meets the commutator, and a wedge-shaped section to fit into a slide on

the end of a substantial brass plate. Carbon brushes are sometimes coppered, and are sometimes used without. Where carbon brushes are employed, a very much larger surface in contact with the commutator must be employed, the density of current taken by any carbon brush not exceeding 40 ampères per square inch, while with copper brushes the density may be as large as 200 ampères per square inch. The undoubtedly better behaviour of carbon brushes over the ordinary copper brush, is the source of some controversy among electrical engineers. The office of the brush in a continuous current machine is twofold. It has to collect the current generated in a half, quarter, or other portion of the armature coils, and pass it on to the outer circuit. It also has to accept the reversal of the current in the coil which is passing under it. Taking any section of the armature whose coils are passing up towards the brush, all the coils are generating current, which is being poured through the coils in front, to that which is under the brush, and thence to the outer circuit. When an individual coil arrives at the brush, it first acts as the connection between the coils behind it and the brush, the current passing from it to its section of the commutator, and then it is itself short-circuited for a very minute interval, while it is passing under the brush. Then the current passing in it is reversed, and the next instant the connection between it and the brush is broken, and it is at this instant that sparking occurs. While the coil is short-circuited, during the period that the adjacent segments of the commutator to which it is connected are passing under the brush, a very heavy current is induced in the coil, and it is this current which is broken, and which causes the sparking when the coil passes from under the brush. One effect appears to be undoubted, carbon brushes wear the surface of the commutator less than copper, they create less friction, carbon itself in its best forms having a considerable lubricating value. In addition, the spark which is formed converts the carbon into vapour, which is carried off by the revolution of the armature, and does less harm in that way than the equivalent action in the case of the copper brush. Similar difference of opinion exists also as to the advisability of coppering carbon brushes. The copper coating reduces the resistance of the carbon, this being an advantage in some respects, and not in others. If, however, the copper coating is not carefully put on, loose laminae of copper are apt to be left in the neighbourhood of the brush, and to give trouble. It is thought that the higher resistance of the carbon brush accounts for the lessened sparking when carbon brushes are employed; but in the author's opinion this explanation is hardly tenable, since the number of carbon brushes must be increased until the resistance of contact and of brush is the same as with copper brushes.

There are various forms of brush holders, the majority, where

carbon brushes are employed, being arranged to keep the carbon block bearing radially on the surface of the commutators. With copper the more favourite arrangement is one which holds the brush tangential to the surface. In the latest forms of brush holders, arrangements are made for throwing an individual brush back, clear of the commutator, so that it can be trimmed without danger; and in the great majority also, arrangements are made for regulating the pressure with which the brush bears upon the commutator, while the machine is running. One form of brush holder, with a carbon brush, is shown in Fig. 87. Sparking at the brushes in all modern machines is very small indeed under all conditions, unless there are very large changes of load, and even then with some forms of machine the sparking is

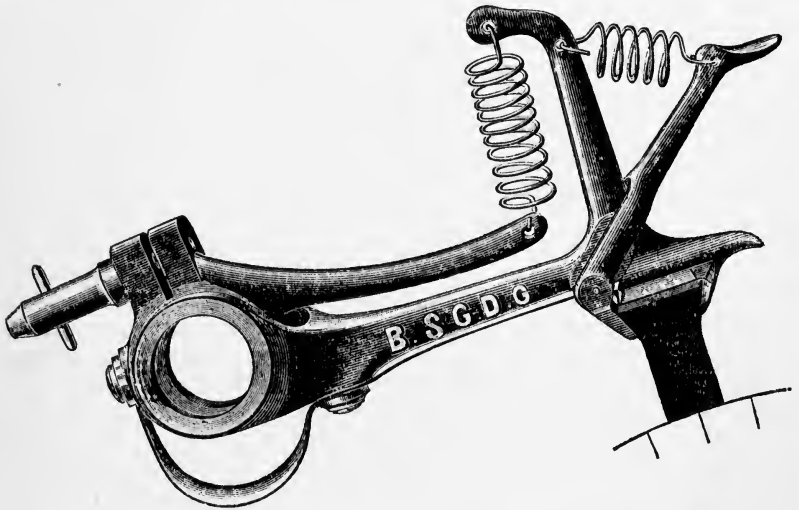

FIG. 87.—One Form of Brush Holder with Carbon Brush, made by Messrs. Santoni. The Arrangement of the Carbon and the Method of Regulating the Pressure are shown very clearly.

still very small. This result is due mainly to the improvement in the general construction of dynamo machines, and is applicable to generators and motors. The conditions for the smallest amount of sparking are well known. They are, in the first place, that the armature coils shall be divided up as much as possible, so that each individual coil has only a very few turns, and therefore its self-induction is very small; and secondly, that the field created by the field magnets shall be always able to overpower that created by the armature, and particularly at the point of commutation. It should, perhaps, be explained that some of the trouble from sparking is due

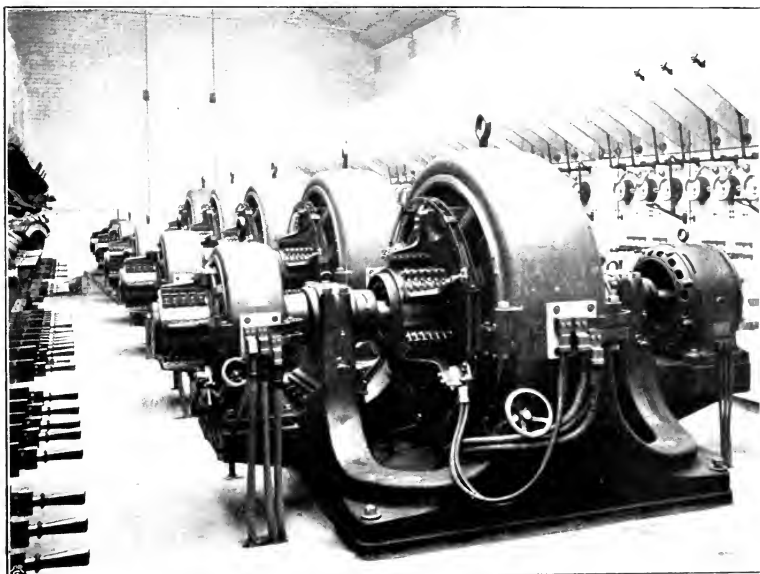

PLATE 9A.—A Sub-station fitted with Westinghouse Rotary Converters. The Station, it will be seen, is very similar to a Generating Station, but there are no Driving Engines.



PLATE 9B.—Water Power Electricity Generating Station, of the North Wales Power Co., fitted by Messrs. Bruce, Peebles & Co.

to the fact that the current passing in the armature coils creates its own magnetic field, and that the resultant field in which the armature coils run is more or less distorted in consequence.

Continuous Current Machines with Commutating or Auxiliary Poles.—In addition to the improvements in construction that have been mentioned, a late development has been made, principally for use with motors, but also applicable to continuous current generators, which still further reduces the sparking at the brushes. The arrangement consists in the provision of auxiliary electro-magnets, fixed between the proper field magnets, and at the points of commutation. These electro-magnets come into action at the moment when the self-induction which has been referred to is taking place, in the armature coil passing under the brush, and are arranged to create a pressure in the coil under commutation, opposite to, and equal to that created by the self-induction of the coil in the ordinary field of the machine, thus reducing the current that is broken when the commutator segment passes from under the brush, to very small proportions.

The Alternating Current Generator

The principal difference between alternating current generators and continuous current generators is, in the alternating current generator the currents are allowed to be delivered into the outer circuit exactly as they are generated. In the continuous current machine each coil generates currents in opposite directions at different portions of the revolution, the currents being arranged all in one direction by the commutator and the brushes. In the alternating current machine no commutator is required, the only arrangement for delivering the current from the armature of the alternator to the outer circuit consisting of, where the armature rotates, brass rings or collars carried on the driving axle, but insulated from it and from each other with copper brushes bearing upon the collars, and taking the currents from them, just as they are generated. There is never any break between the brush or collecting plate and the collar it bears upon, except by accident, or by the machine getting out of order, and therefore there is a complete absence of the sparking which is such a noticeable and often troublesome feature in connection with the continuous current armature. There are four forms of alternating current machines, though as usual modern practice is settling down to one form. In one form, which is perhaps the oldest arrangement of all, the armature coils are carried vertically on the edge of a disc, and they revolve between two crowns of field magnets also arranged in vertical planes. In this form of machine

the coils are wound separately, and usually of a sector or wedge shape, the conductors being in the larger sizes of strip copper with a strip of insulating material between, the coils when wound being securely fixed to a disc of insulating material, which in its turn is securely held on a steel disc carried by the revolving axle. The connections of the adjacent coils of the armature of this type are arranged in the reverse direction, the reason being, the field magnet poles are arranged round the machine in pairs, and so that north and south poles alternate with each other, also north poles in one crown of field magnets face south poles in the opposite crown, and *vice versa*. Each double pair of poles, two on one crown and two on the other, form practically a machine, or a closed magnetic circuit, the lines of force passing from the north pole of one to the south pole of the other, through the yoke connecting the poles on that crown to the north pole on that crown, across the space in which the armature revolves to the south pole of the first crown, and through the yoke to the north pole again. The direction of the lines of force, it will be seen, is reversed at each pair of poles. Commencing at any individual pair, with one of the north poles of the crown, say on the left of the machine, looking at the side, the lines of force will pass from left to right. Between the next pair of poles they will pass from right to left, between the next pair from left to right, and so on. Consequently, as each coil comes up to the lines of force passing from left to right, currents are generated in one direction, gradually increasing as the coil passes into the field, reaching their maximum when the coil is in the strongest part of the field, and gradually decreasing as it passes out of the field. While this is going on with one coil, the coil which is approaching the next pair of magnets will have pressures and currents generated in it in the opposite direction, rising and falling in the same manner. But unless some commutating device is employed, it is necessary to arrange that the currents are delivered to the outer circuit, all in the same direction, all rising together, and all falling together, and the pressures created by each individual coil passing through each set of lines of force, being added together to make the total pressure created by the machine. This is accomplished by reversing the connections of the coils as explained. The arrangement was shown very beautifully in the early Ferranti armature, in which the copper strip, or in the case of small machines, copper wire, was wound around pins placed, half of them at the edge of a disc, and the other half at a certain distance radially from the edge. It will be seen that alternate turns of the winding were in opposite directions. The outer portion would be passing between the pairs of poles in which the lines of force pass from left to right, while the inner portion was passing between the next pairs of poles in which the lines of force were from right to left.

The pressures would be in opposite directions with regard to the conductors themselves, but would be in one direction with regard to the whole of the winding of the armature and the outer circuit. The crowns of field magnets in this form of machine are held in two castings standing vertically upon a bedplate, and so arranged that the armature axle passes through the centre, the bedplate also carrying the pedestals for the bearings of the axle. On the axle also between one bearing and the armature are the collector rings mentioned, the collector brushes being held by fixed brackets secured to the rings upon which the field magnets are fixed. The excitor dynamo is often carried in this type of machine, as in others, on a casting forming a part of the bedplate of the main machine, the field magnets of the excitor machine, which is nearly always bi-polar, being secured to the casting, and the axle of the armature of the excitor running in a small bearing carried by a projection of the casting upon which the excitor itself is fixed, the other end of the excitor axle being connected mechanically to the end of the axle of the alternator. This arrangement is very convenient in many respects, and is very compact. It lends itself to regulation of the pressure of the alternator, because if the speed of the alternator is increased, the speed of the excitor is also increased, and with it, unless the current is reduced at the rheostat, as will be explained, the strength of the exciting current of the field magnets.

In another form of alternator which was made by several firms at one time, and which the Westinghouse Co. have adhered to for some of their machines, the armature is very similar to the armature of a continuous current machine. It consists of thin iron plates, insulated from each other, with slots cut in their periphery, built up into a drum, the slots forming longitudinal grooves, in which the coils are laid. The winding of the coils is almost identical with that of the winding of a continuous current armature, but there are no breaks or junctions in the wire, and no commutator. The collecting rings are carried on the axle as in the disc machine, the copper brushes bearing on them being carried by the fixed part of the machine, usually the bearings in this case; but the rings are not connected to the two ends of the armature coils as in the disc machine, they are connected to two points in the closed winding 180° apart, that is to say, at opposite ends of a diameter of the armature. In this type of machine, also, the arrangement of the field magnets is very similar to that of the multipolar continuous current dynamo. There is the same enclosing cylindrical cylinder of iron or mild steel, with the same magnet cores projecting radially inwards, and with the exciting field coils held on the magnet cores. The field magnet poles are arranged around the cylinder alternately north and south, so that each pair of poles, with the portion of the armature

between them and the portion of the containing cylindrical yoke, may be looked upon as a complete machine, or a closed magnetic circuit. As the armature revolves, the conductors pass across the lines of force, which, as in the disc machine, alternately stretch from the magnet pole to the armature core, and from the armature core to the magnet pole, the pressures and currents created being opposite as each coil passes in front of each pole; but the arrangement of the winding, the arrangement of the coils on the drum, and the arrangement for collecting the current, perform the same office in this form of alternator as reversing the connections of the individual coil does in the disc armature. The pressures generated in the individual coils are added together and delivered to the collector rings. The enclosing field magnet ring is carried on a bedplate, which also carries the pedestals for the bearings of the armature axle, and in some machines of this type the excitor dynamo is also carried on an extension of the bedplate, its axle being connected mechanically to the axle of the alternator; but with the Westinghouse machines the arrangement usually is, the excitor is fixed on the floor in the immediate neighbourhood of the alternator, and is driven by ropes from a pulley at one end of the alternator axle.

In another form of alternator the field magnets are arranged to revolve, the armature being stationary, and this form is gradually acquiring favour, as it presents many advantages. There are no collecting rings, for instance, the current being taken from fixed terminals on the frame of the machine, to which the ends of the armature wires are brought. In this form of machine the main lines of construction are very similar to that of the multipolar continuous current machine, in many respects. There is the same enclosing cylinder, or ring of iron or steel, fixed on its bedplate, the bedplate carrying the pedestals for the bearings of the axle of the machine, as before. On the inner side of the enclosing ring, and cast into the ring in some forms of machine, securely held to it in all forms, are thin discs of iron, having slots cut on their inner edges, the slots forming, when the discs are built into the ring, longitudinal channels in which the wires are placed. The armature coils are made on formers, very much in the same manner as described for the armature coils of continuous current machines, their cotton coverings are dried in a vacuum oven, are then steeped in insulating varnish, dried, wrapped with tapes dried, and fixed in their positions in the slots in the armature cores, these having been previously carefully insulated by troughs of mica, micanite, presspahn, or other suitable material. The field magnet cores are secured to an iron ring or a flywheel held on the driving axle, the exciting coils being slipped over the cores, the coils having been prepared and insulated in a similar manner to that described with continuous current machines,

and being held in place by the pole pieces, which are bolted to the field magnet cores, or the whole thing, or its pole piece with the field coil slipped over the core, may be bolted to a projection on the revolving disc. The poles of the field magnet, as before, are arranged north, south, north, south, all the way round, and the operation of the machine is identically the same as those previously described, the field magnet cores bringing the lines of force to the armature coils, and sweeping them across the coils in place of the coils being swept across the lines of force. The excitor dynamo in this form of machine is usually carried on an extension of the frame of the machine, either of the bedplate or the pedestal carrying one of the bearings for the axle, the axle of the excitor being mechanically connected to the axle of the revolving field magnets of the alternator, as described in connection with other machines. Plates 8A, B, and C show a revolving field alternator for connecting to a steam turbine.

Single, Two, and Three Phase Alternators

The alternators that have been described all generate one current, rising, falling, and reversing, as explained, and are known as single-phase alternators. But single-phase alternating motors, not yet having reached the state required for mining work, single-phase alternating currents have not been used, and are not yet suitable for mining work. Two-phase and three-phase, principally the latter, forms are employed. In the two-phase alternating current generator, as explained in Chapter I., there are two distinct alternating currents generated in the same machine, at one operation, by the revolution of one armature, or set of field magnets, the currents succeeding each other by a quarter of an alternating current period. In the disc machine the two sets of currents require two sets of coils, which must be spaced on the disc so that they succeed each other by the interval named, the second set of coils just entering the fields when the first set are at the point of maximum strength. With three-phase currents in the disc machine there must be three sets of coils spaced so that their pressures and currents follow each other by one-third of a period, the second set just entering the fields when the first set has passed through the point of maximum strength of field, and has reached one-third of the distance towards the point where the field is *nil*, the third set following the second set at the same distance as the second set follows the first, and so on.

In the alternator with a drum armature the only addition that is necessary for generating two-phase currents is, a second pair of collecting rings are fixed on the driving axle, insulated from the first pair, and from each other, with a second pair of collecting

brushes bearing upon them, the second pair of rings being connected to points in the winding also at opposite ends of a diameter, this diameter being at right angles to the diameter at which connection is made for the first phase. By this arrangement two currents are

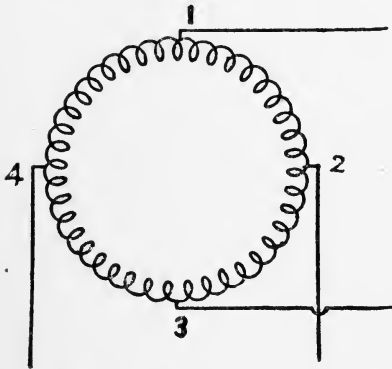

FIG. 88.—Diagram of Connections of a Two-phase Drum Armature. 1 and 3 are the Connections for one Phase, 2 and 4 for the other.

delivered, exactly similar in character, but following each other at 90° interval, or a quarter of a period. This is shown diagrammatically in Fig. 88. For generating three - phase currents, three collecting rings are fixed on the driving axle, with brushes bearing on them, the rings being connected to three points on the armature 120° apart. In the revolving field alternator for two-phase currents there are two sets of coils fixed in the slots in the armature disc, on the inner side of the containing cylinder, and for three-phase currents there are three sets of coils held in the slots.

The four ends of the two-phase coils are brought out to four terminals fixed on any convenient part of the machine, insulated from each other and from the machine, and to these terminals the conductors leading to the outer circuit are connected. For three-phase currents

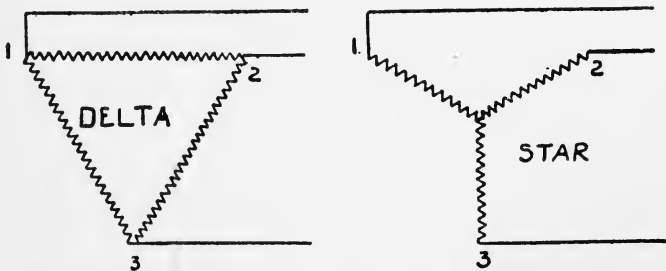

FIG. 89.—Diagram of Connections of Three-phase Armatures. The Δ is the Closed Coil or Drum Armature.

there are two methods of connecting, known respectively as "star" and "delta" windings, the latter being sometimes called "mesh" winding. With "star" winding one end of each of the three coils are connected together, the junction of the three forming what is

termed the neutral point, the other end of each of the coils being brought out to three terminals, insulated from each other and from the machine, fixed at any convenient point, as before, and to these terminals the cables for the service are connected. The connections of the three-phase system in the drum armature alternator is the best example of "delta" or "mesh" connection. The armature coils of a three-phase revolving field alternator may, however, be connected in this way. Diagrams of the connections, with "Delta" and "Star" arrangement, are shown in Fig. 89.

The Output and Number of Poles of Single, Two, and Three Phase Alternators

The number of poles required by any alternator is the same, whether it be for single, two, three, or more phases, and it depends simply upon the periodicity, that is to say, the number of cycles, and the speed at which the machine is to run. The number of cycles means the number of reversals the machine is required to produce, and is obtained for any given machine by taking the number of magnetic fields, that is to say, half the number of single poles, and multiplying by the number of revolutions per minute. With a periodicity of 50 per second, which equals 3000 per minute, if a machine is to run at, say, 500 revolutions per minute, it must have 6 magnetic fields, or 12 poles. With a periodicity of only 25 and the same speed, half the number of poles would be sufficient. On the other hand, with lower speed, say in the case of a large flywheel alternator running at 100 revolutions per minute with a periodicity of 50 cycles per second, there must be 30 magnetic fields, or 60 magnetic poles. And this number is required whether the machine is furnishing one, two, or three currents.

The output of a two-phase machine is larger than that of a single-phase machine, while the output of a three-phase machine is the same as that of a two-phase. The proportion between the output of any given machine, as single-phase and as two or three phase, is as approximately 65 to 100, the single-phase machine only generating 65 per cent. of the energy generated by the two or three phase machine. With the two-phase machine the output is measured by the product of the highest *virtual* or *effective* pressure, multiplied by the highest *virtual* or *effective* current obtainable in one phase, from the machine at the same moment, the product being multiplied by 2. With three-phase machines the output is measured by the product of the highest *effective* current in any phase, multiplied by the highest *effective* pressure when the highest virtual current is passing, the product being multiplied by $\sqrt{3} = 1.71$. There is a difference

in the arrangements of the pressures with the star connection and mesh connection, though it does not affect the total output of the machine. With star connection the pressure between any two terminals of the machine is 1.71 times the pressure between any terminal and the neutral point, the junction of the inner ends of the three sets of coils. In mesh connection the current passing out to the outer circuit through either of the cables is 1.71 times the current passing in the coils connected between any two terminals.

The Inductor Alternator

In this form of machine, which has, so far as the author is aware, not been much employed, the whole of the conductors are stationary, and the changes in the number of lines of force passing through the armature coils is brought about by changes in the magnetic circuit of the machine. It was explained in Chapter I. that the number of lines of force passing through any magnetic field, and, in particular, passing across the small gap allowed for the moving coils of a generator, depends directly upon the exciting force measured by the product of the current in amperes, multiplied by the number of turns the current made round the field magnet cores, and inversely on the resistance or reluctance of the magnetic circuit in which the air space, or the space left for the armature coils, forms a part. In the disc, the drum, and the revolving field type of alternators, the reluctance of the magnetic field is changed by varying the position of the armature core and the field magnet cores with reference to each individual coil, this leading to a change in the number of lines of force passing through each coil, and to the creation of an electrical pressure in consequence. In the inductor alternator the change in the magnetic reluctance is produced by motion of a portion of the iron forming the magnetic circuit itself. In the inductor alternator the armature coils are fixed, and the exciting coils are also fixed, both being held usually in positions on the inner side of an enclosing iron or steel ring, similar to that employed in the multipolar continuous current generator, and the other alternators that have been described. The position of the exciting coils of any magnetic circuit is immaterial within certain limits. They may be placed in any convenient position, providing that they create the necessary lines of force in the direction required for the operation of the machine. The armature coils must be in such a position that any changes created in the number of lines of force passing through the field must take place in them; that is to say, the full changes in the number of lines of force must take place in the portion of the magnetic circuit occupied by each individual armature coil. In the inductor

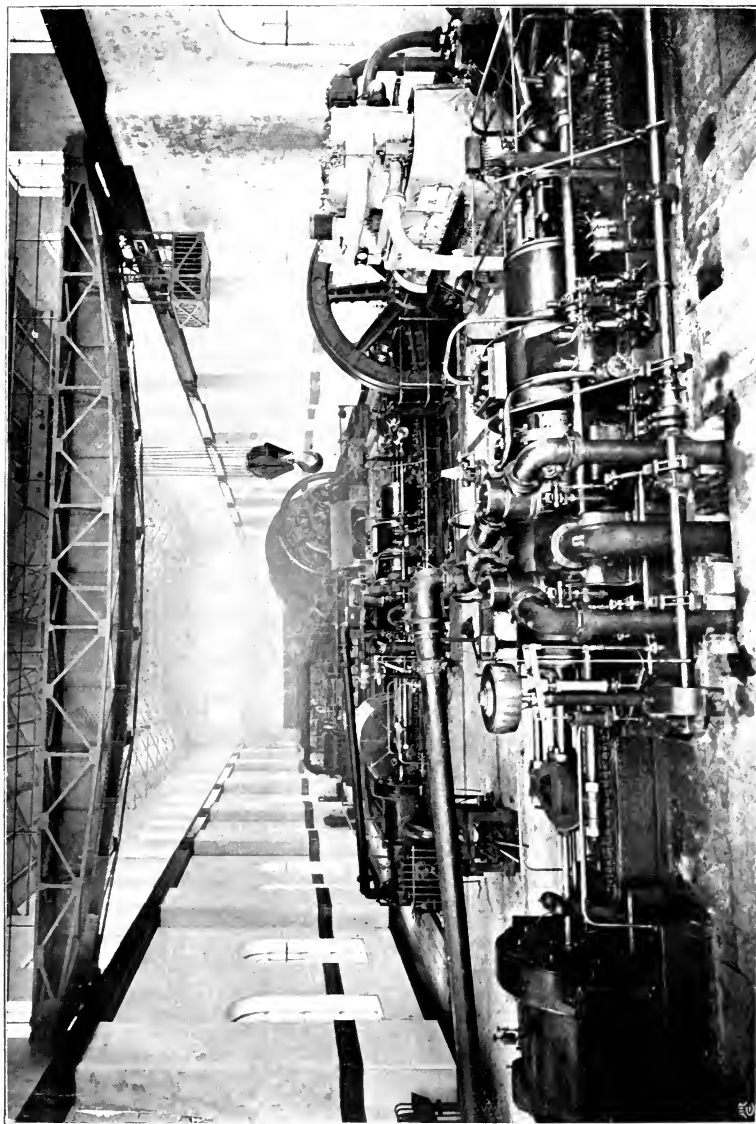

PLATE 10.—Electricity Generating Station at Messrs. Beardmore's Works, in which Oechelhausen Two Cycle Gas Engines are employed, with Producer Gas, the Engines being directly connected to the Dynamos.

machine there are a number of magnetic poles, north, south, north, south, arranged around the enclosing ring, just as in the other machines; and it may also be split up into a number of magnetic circuits, each consisting of the portion of the outer containing ring carrying a north and a south pole, with the connecting yoke, and a portion of the iron armature, as it is practically, carried by the revolving member. The revolving portion of the apparatus consists of the axle and an iron wheel with iron projections, and as the axle revolves, the iron projections approach the poles formed on the inner side of the enclosing ring, very much as the field magnet cores of the revolving type do, the approach of the cores to the poles reducing the magnetic resistance, and their recession increasing its resistance, the result being an increase of lines of force and an increase of pressure as the projecting iron comes up to the field magnet pole, and a decrease of lines of force and a decrease of pressure as it recedes. The necessary reversal of connections required to make the pressure, delivered to the outer circuit all in the same direction, is arranged by having two sets of armature coils and two sets of pole pieces, but with only one set of revolving projections.

Secondary Batteries or Accumulators

Secondary batteries have not yet been much employed in mines, but where they can be, they form another source of economy under certain conditions. The secondary battery or accumulator is also known as a storage battery, from the fact that electricity is poured into it from a dynamo, and that afterwards electricity can be taken from it for a certain period. There are two forms of secondary battery on the market, though one of them has hardly attained commercial success as yet, viz. the lead lead-oxide battery, and the iron nickel battery that has been worked out by Mr. Edison. In every secondary battery there are practically three distinct portions, the electrodes or carriers, the active material, and the liquid or electrolyte. In the lead lead-oxide battery the electrodes are grids of lead. In some of the later forms a lead antimony alloy is employed to give greater stiffness to the grid, and therefore to allow of its being made lighter. The grids are arranged in various forms, but all designed to have cavities formed in them for the active material, of such a nature that in the course of charge and discharge, during which considerable expansion and contraction of the active material takes place, the tendency, which is only too common, of the active material to chip off, shall be reduced to the lowest possible limits. In the lead lead-oxide battery the active material consists of two oxides of lead; a low oxide is placed on the negative plate, and a

higher oxide on the positive plate. In some forms the active material of the positive plate is formed by electro-chemical action, out of the mass of the plate itself, by what is known as the Planté method. The grids with their active material are suspended vertically in glass or lead-lined wooden vessels in dilute sulphuric acid. The current from a continuous-current dynamo is brought to the positive plate, it passes through the liquid to the negative plate, and thence back to the dynamo. In its passage it oxidizes the higher oxide upon the positive plate, raising it to a yet higher oxide; it decomposes a portion of the dilute sulphuric acid, the oxygen passing to the positive plate, and forming the source from which the positive active material is oxidized; and it reduces the lower oxide upon the negative plate to the form of lead, in a spongy condition, the hydrogen from the decomposition of the dilute sulphuric acid combining with the oxygen liberated from the negative active material to form water. It may be said, in fact, that the operation of charging a secondary battery consists in the transference of a certain quantity of oxygen from the negative active material to the positive active material. The higher oxide of lead formed on the positive, and the spongy lead formed on the negative plate, in the presence of the solution of sulphuric acid, which has become considerably stronger during the process of charging, forms the most powerful galvanic couple that is known. The electrical pressure between its two plates when first charged, and when the gas which is present and which has not been absorbed by the active materials has passed off, is two volts. When the secondary battery discharges, the reverse operations take place; oxygen is transferred from the active material of the positive plate, *via* the solution of sulphuric acid, to the active material of the negative plate. The active material on the positive plate is reduced to the oxide from which it was formed by the charging current, the active material on the negative plate is re-oxidized to the form from which it was reduced by the charging current, and the liquid electrolyte recovers the water that was taken from it by the charging current, the strength of the solution again decreasing.

In the Edison secondary battery the electrodes or carrier plates are thin plates of nickel steel, out of which rectangular spaces have been punched, and into these spaces perforated boxes, also of nickel steel, are forced under hydraulic pressure, so that the boxes and the carrier plate form one homogeneous mass. The perforated steel boxes contain a salt of iron in a finely divided state on one plate, and a mixture of a salt of nickel and carbon, both in a finely divided state, on the other plate. The electrolyte is caustic potash. The cell, when fully charged, has a pressure between its terminals of only 1.6 volts.

Secondary cells are usually made up with a certain number of

plates in each cell of a certain size, the sizes of the cells being arranged according to the work they are intended to perform, and their capacity is given as so many ampère hours; that is to say, a cell with a certain number of plates, each of a certain size, will furnish a current of a certain strength for a certain number of hours. The capacity of secondary cells varies with the period of discharge. It is greatest for long periods, such as ten hours, and it becomes less as the strength of the current taken from the cell increases, and the period of discharge decreases. Thus, with a cell listed as having a capacity of 150 ampère hours, this will mean usually that it will give fifteen ampères for ten hours.

If the rate of discharge is raised, say, to twenty ampères, the total capacity will be reduced to 120 ampère hours, or thereabouts, and it will be reduced still further if the rate of discharge is further increased. When a secondary battery is being charged, the gases which are formed by the decomposition of the liquid electrolyte, add to the back pressure created within the cell, which has to be overcome by the charging current. With a lead lead-oxide battery, each cell when charging has a back pressure of $2\frac{1}{2}$ volts, and the charging current must have that pressure, and, in addition, a pressure sufficient to overcome the resistance of the cell itself, that offered by the electrolyte, the plates, and what is known as the contact resistance between plates and the electrolyte. The resistance of accumulators is usually very small compared with that of primary batteries, and the additional pressure required to overcome the resistance of the cell is not great, but it must be provided for.

From the moment that the charging current ceases to pass through the accumulator, or if the pressure of the charging current falls below that necessary, as described above, the pressure of the cells commences to fall. The gases which give the additional half-volt pressure usually quickly disperse, or recombine, and the pressure of the cell falls to 2 volts, or in some cases a little over, 2.1 say, very quickly. The pressure of the secondary cell also commences to fall, apart from the escape of the gases, after the charging current has ceased to pass through it. When current is being taken from it, the pressure falls approximately in proportion to the strength of the current, and in practical work no cell should ever be allowed to fall below a pressure of 1.8 volts, before it is recharged. Where cells are not used they should be carefully tested and watched, and given an occasional charge to keep them up to their full pressure. Leakage takes place with all batteries, both primary and secondary. A connection exists between the terminals of adjacent cells, both primary and secondary, by way of the moisture which is nearly always present on the outside of the cell, and upon the box or shelf on which they rest, and this connection, though it has a path of high resistance, allows a leakage current

to pass, which is always going, and which gradually works the cells down. With secondary batteries it is usual to support the cells upon insulators of porcelain, arranged so that the leakage current has to pass over the surface of a film of oil, this introducing a very high resistance into its path. Secondary batteries also should never be allowed under any circumstances to be fully discharged. The rule given above as to not allowing them to go below a pressure of 1·8 provides for this. If they are allowed to go below that, action takes place between the lead grid and the active material, resulting in the formation of lead sulphate upon the surface of the lead grid, the sulphate having a very high resistance, and practically in course of time stopping the passage of both charging and discharging current, and rendering the cell useless. The sulphate is afterwards formed into active material by the charging current, when the cell is put right, but it is at the expense of the substance of the plate, the latter gradually becoming brittle and breaking up, this being one of the great troubles in connection with secondary batteries, where they are not properly looked after.

Accumulators are employed, in generating stations, to assist the generators at times of heavy load, the accumulators taking up the surplus power during times of light load, just as the thermal store does with the Rateau turbine. In order to charge them, however, from the regular supply service, the pressure has to be raised for the purpose by a "Booster," as described below. They can only be used, at present, with continuous currents.

Boosters

The booster is an apparatus, as its name will probably make known, that has been introduced from America. It is a motor generator, and its office is to "boost," or to increase, and in certain cases to decrease, the pressure delivered by the generators at any part of the distribution cables. It is also employed for providing the necessary increase of pressure for charging accumulators from the ordinary generators employed in the generating station. Where accumulators are employed to assist the ordinary supply service, they must furnish current at the same pressure as that furnished by the generators, and it is evident that they cannot be charged with a pressure of something above $2\frac{1}{2}$ volts per cell from the generators direct, and give the generator pressure when called upon. The booster overcomes the difficulty. In this case it consists of two machines, or it may consist of one machine with two windings on its armature, and two commutators. Where it consists of two machines, one machine receives current as a motor from the supply service,

driving the other machine as a generator, and the second machine generates current at sufficient pressure to charge the accumulators, the pressure of the current generated being regulated by the current in the field magnet coils. Where a single machine with two wires on its armature is employed, the field magnets and one winding of the armature receive current from the generators, the other winding furnishing current at the pressure required for charging the accumulators. Where the accumulator is employed to assist the generators in taking what is called the "peak of the load," the portion of the load, where it exists, which only comes on at a certain portion of the day, and only for a short time, and is over and above the ordinary load of the station, the accumulators are sometimes allowed to discharge through the booster into the supply service, the booster in this case reducing the accumulator pressure to that of the supply service, the accumulator current only being employed for a short period. During recent years there has been a development of this, known as the "reversible" booster, which is always connected to the accumulators, and to the generator service. With this arrangement the generators and the engines driving them are made of less power than would otherwise be necessary, and are always furnishing current right up to their full output. Whenever there is a margin between the current taken by the supply service and that furnished by the generators, it is taken up by the accumulator through the booster; and whenever the demand of the supply service is more than that able to be furnished by the generators, the difference is made up by the accumulators again through the booster. In practice the reversible booster is constantly either transmitting current to the accumulator, or from the accumulator to the supply service, and the arrangement has resulted in a large increase in the efficiency of the accumulator. In ordinary work the efficiency of the accumulator cannot be taken at more than 70 per cent., more frequently it is less, as it must not be discharged below a pressure of 1.8 per cell. The efficiency of the booster cannot be taken at more than 80 per cent., so that the combined efficiency will not exceed 55 to 60 per cent. It is claimed that with some forms of reversible booster, efficiencies as high as 80 per cent., inclusive of accumulator and booster, have been obtained, this being due, in the author's opinion, to the fact that the pressure of the gases generated in the course of charging the accumulator is made use of to a certain extent, instead of being lost in the ordinary arrangement for charging accumulators.

Motor Generators

The motor generator has been referred to in Chapter III., and in connection with boosters. As explained, it consists of two machines, one of which receives current as a motor, and the other generates current. The two machines may be continuous-current machines, or one may be arranged for alternating current, while the other is arranged for continuous current. The two machines are always arranged to deal with the same quantity of energy, and the office of the combined machine is to convert the electrical energy, say, of a power service from one form to another. In the simplest form there are two identically similar continuous-current generators, usually of the two-pole type, though with the development of dynamo construction four-pole machines are becoming common, even for small sizes. They are mounted on one bedplate, and may be complete in themselves, each being capable of removal, or the bedplate may form part of the combined machine, the two sets of field magnets being secured to it, or even forming part of the same casting. Each machine has its own field magnets, its own armature, its own commutator, and its own brushes and terminals. There will be two bearings carried on pedestals fixed to the bedplate at the ends of the combined machines, but there is usually no third bearing between them. The axles of the two armatures are connected together in the space between the two machines, and they revolve together. The two machines are wound for different pressures, one being wound to receive current at the pressure of the supply service, from which it is to convert, and the other being wound to generate current at the pressure desired. The motor may also be series, shunt, or compound wound, but is more usually shunt wound, though it may have a series coil to assist it in starting. The generator may be also series, shunt, or compound wound, but it will be more usually shunt or compound. A modification of this arrangement that is made by some firms is also a modification of the machine described on p. 200 for use with the three-wire distribution system. It is known as the Dynamotor. It has one pair of field magnets only, one armature only, but the armature has two windings, two commutators, and two sets of brushes. The field magnets are excited by the supply current, and one of the windings on the armature receives current and turns the armature in the field created by the field magnets, as a motor, the other winding on the armature generating a current at any pressure that may be desired. The arrangement, as before, converts a continuous current of any pressure to a continuous current of any other pressure. It should not be employed for pressures which differ to any great extent, and it has the disadvantage, as against the motor

generator with two distinct machines, that there is an electrical connection between the wires, cables, etc., at the two pressures through the insulation between the coils of the armature, whereas there is no electrical connection between the two in the motor generator proper, and there is not much space with a double winding to provide insulation, where one of the pressures is comparatively high. On the other hand, the arrangement is cheaper in first cost than two machines.

Another arrangement is, the motor may be arranged to work with two or three phase currents, and the generator to create continuous current pressures. As before, the machines are of the same output, and this enables continuous currents to be supplied at any convenient pressure, say, for signals for incandescent lamps or for arcs, from a two or three phase power service, no matter what the pressure of the power service may be. If the pressure of the power service is high, it is a simple matter to transform it down by means of the stationary transformers to be described, to a conveniently low pressure, at which it can be delivered to the motor. The reverse arrangement may also be made, the motor machine may be for continuous current, and the generator for alternating, which, again, may be for single, two, or three phases, as convenient. A motor generator for transferring three phase to continuous currents is shown in Plate 7B.

There is yet another arrangement, designed particularly for converting alternating to continuous currents, or continuous currents to alternating, known as the "Rotary Converter." The rotary converter, as usually constructed, is a drum-wound alternator. It may also be looked upon as a multipolar continuous-current dynamo with a drum-wound armature. The armature has the usual commutator for continuous currents at one end, and at the other end it carries two, three, or four collector rings, with brushes bearing upon them, as in the alternating-current machines, the collector rings being connected to points 180, 120, or 90 degrees apart on the armature, as in the drum-wound alternator, according as single-phase, three-phase, or two-phase currents are required. There is one important feature in connection with the rotary converter: the pressures bear a certain definite relation to each other, the alternating current pressure being always less than the continuous current pressure, the ratios being, with single phase, 70·7 per cent., with two phase, 70·7 per cent., and with three phase, 61·2 per cent. of the continuous current pressure. If a continuous current is delivered to the motor side at 100 volts, the single or two phase current generated is 70·7 volts, and the three phase 61·2 volts, while a motor pressure of 70·7 two phase, or 61·2 volts three phase produce 100 volts continuous on the generator side. The current is increased or decreased in proportion. Thus with 100 volts continuous motor pressure, 70·7 volts two-phase currents are

generated, of 70·7 amperès in each phase, and three currents of 94·4 amperès with three phase.

Rotary convertors may be employed in the same manner as either the continuous current machine or the alternating machine would be if steam driven, but certain care has to be taken in connection with them. A sub-station, consisting of rotary convertors, is shown in Plate 9A.

Balancers

The balancer is an apparatus, as will be explained in Chapter V., that is employed in the distribution of current on what is called the three-wire system. It is really a continuous-current motor generator, in which the two machines are identically alike, and it is sometimes arranged, as will be explained, for one machine, receiving current from one portion of the service, to drive the other machine, which generates current for delivery to the other portion of the service. Either machine may act as the motor at times, the other machine acting then as the generator, and either machine may act as generator when the other one acts as motor. The two machines may also be, and are frequently in the latest practice, driven by a steam engine. In this case each machine acts as a generator, only delivering current, the pressure of which is controlled by apparatus that will be described, to different parts of the service.

Continuous-current Machines with Two Armature Windings

Continuous current machines are made by a few firms, though, the author understands, not in large sizes, with two identically similar windings on the armature, and two commutators, one at each end. The machines are separately excited, this being the more convenient arrangement, though it is not absolutely necessary. The object of this form of machine, as will be explained in Chapter V., is for use with the three-wire system of distribution. The two windings of the armature are connected in series, leaving the positive end of one and the negative end of the other as the terminals of the machine, the middle or joint terminal forming the middle or neutral terminal of the three-wire system.

Stationary Transformers

The stationary transformer is a device that has been very much employed in the distribution of electric currents for both power and lighting by alternating currents. It is a development of the

induction coil, the coil that is employed for medical use, and for X-ray apparatus, and similar arrangements. Its useful property is the ability to convert a current of low pressure to one of high pressure, or a current of high pressure to one of low pressure.

In the ordinary induction coil there is a straight iron core consisting of a bundle of iron wires usually slipped inside an ebonite tube. Outside the ebonite tube is wound a coil of comparatively thick wire. Outside of the thick wire is placed a good thickness of insulating material, depending upon the pressure it is desired to create, and outside of that a long length of fine wire is wound. The thick wire is known as the primary, and the thin wire as the secondary. A contact breaker completes the arrangement, and a battery is connected to the primary coil through the contact breaker. When the current first passes in the primary coil, a current is generated in the secondary coil, whose pressure is approximately as many times that of the battery furnishing the current as the number of turns of the secondary coil are greater than the number of turns of the primary coil. When the current passing in the primary coil is broken by the action of the contact breaker, another current is furnished in the secondary coil of a pressure similar to the first current, but in the opposite direction, the first current being in the opposite direction to that of the primary current, and the second current being in the same direction.

As in all these matters, it is not necessary that the current shall be actually broken for inductive action to take place between the two coils,—if the primary coil is connected to a source of electricity, and any variation occurs in the strength of the primary coil, it is reflected in the secondary coil by the generation of a current either in opposition to that of the primary coil, or in the same direction, the pressure in each case depending upon the arrangement of the magnetic circuit of the induction coil, and upon the ratio between the number of turns in the primary and in the secondary coils. Hence, it was a natural development of the induction coil, though it only occurred to a few pioneers, when the alternating current had established itself for the delivery of a current at a distance for electric lighting, that the induction coil should be utilized for the purpose of delivering currents at high pressure, and using them at low pressure. But the induction coil, as used in medical and X-ray work, shocking coils, etc., is a very inefficient apparatus, for the reason that no attempt has been made in it to lower the resistance of the magnetic circuit. Lines of force issue from the ends of the iron core, and they form closed curves passing on both sides through the air between the ends of the core, but the length of the air path being so great, the resistance offered to the passage of the lines of force is very high indeed. In the practical modern transformer this defect is made good.

Transformers are constructed on two principal main lines, called respectively, core transformers and shell transformers. In both forms the iron forms a closed circuit, and the iron core is built up of a number of thin sheet iron plates, insulated from each other very much in the same manner as the plates of the armature of a dynamo. The difference between the construction of core transformers and shell transformers is, in the core transformer the primary and secondary coils are slipped over the iron cores, in the shell transformer the core surrounds a large portion of the coils. In the core transformer the thin iron plates are built into a framework in which there are two or three legs, according as the transformer is for single, two, or three phase currents. The legs which form the cores inside the coils are held between terminal frames, and it is arranged that the upper terminal frame can be removed, the wire coils slipped over the core legs, the terminal frame replaced, bolted into position, and the whole thing then forms the closed magnetic circuit described. In the shell transformer the coils are made in the form of large open rings nearly rectangular in section, the iron core plates being then fixed so as to surround the coil legs.

The operation of the transformer is precisely the same in the two forms, the object of the construction in each case being to reduce the magnetic resistance, and thereby to reduce the losses in the iron and in the copper. In the core form of transformer the coils in which the pressures are lowest are held nearest the iron, those in which the pressures are highest being outside, and there being substantial insulation between the two. The insulation between the primary and secondary coils consists usually of a cylinder of asbestos or some similar material. The inside coil is insulated from the iron as well as from the outside coil. Transformers are employed for raising the pressure as well as for lowering it, and in that case the primary coils would be those in which the pressure is lowest. In the shell type of transformer, the primary and secondary coils are made in sections, and are interleaved; that is to say, the secondary coils are distributed between the primary coils, so that the induction shall be also distributed evenly over all the coils. The complete mass of primary and secondary coils is carefully insulated from the iron cores which surround them, in very much the same manner as armature coils and field magnet coils are insulated from their iron supports, as has been explained.

The operation of the transformers is as follow. Taking first a single-phase alternating current. As the strength of the current rises in the primary coil, the strength of the magnetic field also rises, and a pressure is created in the secondary coils proportional to the rate of rise in the strength of the magnetic field. After the primary current has passed its maximum, the strength of the

magnetic field commences to fall, and the pressure in the secondary coils also falls till the second zero is reached, the rise of current on the negative side in the primary coils being followed by a rise of pressure in the secondary coils to the maximum, followed by a fall of pressure, and so on.

It was explained in Chapter I., under the head of Self-induction and the Power Factor, that, owing to the induction which takes place when a pressure is changing in strength, as an alternating pressure is, the current which results from the application of a pressure to a given conductor follows the pressure a certain time, a certain fraction of the whole period of the alternating cycle, after the pressure, and this happens in the case of the stationary transformer. The current in the primary coils follows the application of the pressure a little after the pressure, and consequently the pressure in the secondary is also a little after the pressure in the primary. But this, again, depends entirely upon the construction of the transformer, and upon the amount of work it is doing. With modern transformers it is claimed that when the transformer is loaded up to its full capacity of transformation, the power factor (see Chapter I., p. 20) is as high as 0.99; that is to say, the current lags only a very short period indeed behind the pressure, and there is only a loss of 1 per cent. in the transformation. When the transformer, however, is very lightly loaded, as where it is used for lighting purposes, and during the major portion of the day very little current is being taken from it, the power factor may be as low as 0.5; that is to say, the current in this case will lag very considerably behind the pressure, and there will be a practical loss of 50 per cent. in transformation. Losses in transformation due to the power factor are increased by the presence on the secondary circuit of inductive apparatus, such as induction motors, whose construction will be explained in Chapter VI. The matter of the lag of the secondary pressure behind the primary makes no difference whatever either to the lighting service where lights are taken from the current, or to the power service; it only makes a difference in the power absorbed by the generator for any given work.

The stationary transformer is self-regulating. It calls up from the primary service as much current as it requires to furnish the current demanded by the lamps or motors on the secondary service, and when lamps or motors are switched off on the secondary service, the secondary coils cut off the supply that is no longer necessary from the primary service. And the self-regulation arises from the same inductive action which causes the transformation itself. It was explained in Chapter I. that induction took place between wires forming parts of different circuits when currents rose or fell in either of them, and that induction also took place in any circuit when the wire of the circuit was coiled on itself, as in an electro-magnet, when changes took

place in the current passing in the circuit. This is the principle, it will be remembered, upon which the choking coil used with alternating current arc lamps is worked. In the stationary transformer it leads to self-regulation in the following manner. When the secondary circuit is open, no current passing through its coils, the primary coils act exactly in the same manner as the choking coil of an arc lamp. They choke back the current that is not wanted, only allowing the minimum current to pass that will create a magnetic field in the core of the transformer, sufficiently powerful to respond quickly when the secondary circuit calls for current. When currents pass in the secondary coils, it will be remembered that they are in the opposite direction to those in the primary coils, with the result that as the currents passing in the secondary coils are increased, the choking action in the primary coils is lessened, and more and more current passes in a properly designed transformer, exactly in proportion to the requirements of the service.

There are two sources of loss in the stationary transformer, known respectively as iron loss and copper loss. The copper loss is that due to the transformation of the current passing through the coils of both primary and secondary into heat. It is known as the C^2R loss, and it is measured in both primary and secondary coils by the square of the current in each multiplied by the resistance of each. The iron loss is that due to the heating of the iron core by what is known as hysteresis. It was explained in Chapter I. that on Professor Ewing's theory of magnetism, the molecules of the iron which are being magnetized swing round on their axes, swinging back when the impelling force ceases, swinging in the opposite direction, in obedience to the impelling magnetizing force in the opposite direction, and so on. In the cores of transformers, the iron molecules are subject to magnetizing forces in opposite directions, changing twice during every cycle of the current; hence assuming Ewing's theory to be correct, the molecules are subject to a continued swinging to and fro during each cycle, and this results in the liberation of a certain quantity of heat in the iron itself. The energy delivered to the iron core in the form of heat in this manner, must be taken from the current supplying the transformer with energy, and is therefore a source of loss. Modern transformers are designed so that at full load the iron losses and the copper losses are equal, the sum of the two being only the small fraction mentioned above, 1 per cent. of the total power dealt with by the transformer.

Transformers for Single, Two, and Three Phase Currents

The construction of transformers for single and two phase currents is practically the same. With the core-type transformers there are two legs, carrying the coils as described, and the coils are frequently arranged so that the transformer can be employed on services for 100 or 110, and for 200 or 220 volts, the coils on the two legs being connected in parallel for the lower pressure, and in series for the higher pressure. For two-phase services, exactly the same construction is employed; there are two legs, but each leg is connected to one of the phases. With three-phase services there are three legs, each having its own coils, and each set of coils being connected to one phase. For a larger number of phases there would be more legs in proportion. It will be understood that in the construction for the single-phase transformer two legs are necessary, because a complete magnetic circuit cannot be formed in any other way. With shell transformers the arrangement, for single, two, and three phase, is made in various ways, but the main lines, as described above, are followed. There is practically no difference between the construction of a single and a two phase shell transformer, except that there are separate sets of coils with two-phase, while there is only one with single-phase; and by a simple extension, three-phase have three separate sets of coils.

Cooling Stationary Transformers

It was mentioned above that the coils and the iron core both had a certain quantity of heat liberated in them, and it is important that the heat shall be dissipated as it is formed for two reasons. As was explained in Chapter I., all metals increase their resistance with increase of temperature, and in a definite proportion to the increase; therefore, as the temperature of the copper coils of a transformer increases, their resistance also increasing, the current passing through them decreases, and according to the formula $H = C^2R$, the loss in the coils, with a given current, also increases. In the case of the heating of the iron another curious result was discovered by Mr. Mordey, and confirmed by other observers, some few years since, viz. that if the iron cores on transformers are allowed to be raised to a certain temperature, what has been termed "ageing" takes place. The iron increases its magnetic resistance, the output of any given transformer being thereby decreased. Both of these troubles are got rid of by not allowing the transformers to increase their temperature

beyond a certain figure. In the best modern transformers the increase of temperature does not exceed $45^{\circ}\text{C.} = 113^{\circ}\text{Fahr.}$, and this result is accomplished partly in the construction of the transformers, by allowing plenty of iron and plenty of copper, by using only special brands of iron or steel, specially annealed for the purpose, and only pure copper, and being very particular about the insulation of the copper; and partly by arranging to dissipate a portion of the heat liberated. There are three methods of dissipating the heat liberated in a transformer—by air, by oil, and by water. In this country water has not been employed, but it has been in America. With air-cooled transformers, the transformer, constructed as described, is fixed inside an iron case, which is provided on its outside with ribs or corrugations intended to increase the surface in contact with the air, and the whole apparatus is fixed either in some position where there is a natural draught sufficient for the purpose, or a current of air is passed over it by the aid of a fan. The oil-cooled transformer is fixed inside a tank which is filled with oil whose flash-point is about 350°Fahr. , the oil performing the double office of dissipating and equalizing the heat, and sealing up any defects in the insulation that may arise. In America the Allis-Chalmers Co. construct modifications of the oil-cooled transformer, in some of which the tanks are fitted with ribs, so that the air takes a part in the cooling, and in others there is a coil of pipe enclosed in the transformer chamber, through which water is circulated, the office of the water being to carry off heat from the oil, the oil in its turn receiving the heat from the transformer coils and the ironwork. If the matter is worth the additional complication, and where there is a cold-storage plant on the ground, as possibly many collieries will have before many years are over, especially those having high temperatures at great depths, cold brine at any desired temperature could be circulated through a pipe enclosed in the transformer chamber, and any quantity of heat could be carried off thereby. Further, at those collieries where compressed air is in use, a blast from a compressed air plant should have a very cooling effect upon transformers.

Arrangement of Apparatus in the Generating Station

For the economical working of any electricity-generating station, certain conditions have to be complied with. The generating apparatus are usually divided into units, and, where it can be so arranged, each unit with its accessories is complete in itself. Thus a unit will consist of a generator, with its excitor where alternating currents are employed, its driving engine, whether this be steam, gas, oil, or water,

together with sufficient apparatus to provide the gas or steam engine with sufficient gas or steam to do the full work the unit is intended to deal with. Thus, with steam engines, each generator will have its engine, its bank of boilers sufficient to supply steam for the full output of the generator its condensers with its circulating and air pumps, its feed pumps, etc. With gas engines the engine will have its own gas producer and scrubber, etc., which will be of sufficient size to provide gas for the full output of the generator. There are, of course, variations of these arrangements. The whole of the condensing of any station, and, in later practice, of a group of stations, may be performed at one condensing station. The whole of the feed-water may be dealt with in one set of feed-water heaters and economizers, and so on. Plate 9B shows a generating station run by Pelton water wheels. Plate 10 shows a generating station driven by Oechelhausen gas engines. Plate 11 shows a complete suction gas engine plant.

The Size of the Units

The size of the unit is naturally of considerable importance, and it is governed by two considerations. The unit, or a multiple of the unit, preferably the unit itself, must be sufficiently large to deal with the whole of the load during times of light load. Practically the extent of the light load fixes the size of the unit, though where there is a very considerable difference between the light load and full load it is sometimes arranged that the light load is dealt with by a small unit, and the full load by one or more larger units. The best plan, in the author's opinion, is to make the size of the unit that which will deal with the light load, and to multiply the units to whatever extent may be required to deal with the full load. The other consideration upon which the size of the unit depends, is the question of the efficiency of the plant as a whole, and the cost of the plant. The cost of very large units is very much less per kilowatt than of smaller units. Also, large units are usually more efficient, they make a smaller charge for converting mechanical to electrical energy than the smaller units. Between, however, the size of the unit that will deal comfortably with the whole of the light load, and that which would deal with the full load, in a smaller number of units than would be required when making the light load the unit, there is not very much difference either in the cost per kilowatt of the machinery, or in the efficiency. In any case, the latest practice is, a certain number of the units decided upon are fixed, the generators and their driving accessories in one building, the boilers and their accessories in an adjoining building, the total number of the units being sufficient to deal with the whole of the load the generating station may be

required to supply, plus at least one unit as a stand-by against the breakdown of any of the others. It then becomes a very simple matter, as will be explained in Chapter V., to proportion the number of units in service to the load, and to remove any unit from service that shows signs of failing, and to replace it by a spare unit in a very short time. There is another question that deserves consideration, especially in connection with mining work, and that is how far each individual unit should be worked up to its full output. The difference usually, between the efficiency of units working at full load and at three-quarter load, is not great. The practice in some generating stations is to work all units in the service at their full load, but this has the disadvantage that there is no margin in case of a sudden call. The author would prefer, for mining work at any rate, that units should be worked at something like three-quarters their possible load, or even less. As all modern generators are constructed to work at twenty-five per cent. overload for an hour, without danger, this means that in case of accidents, such as unfortunately happen occasionally, where two or more generators break down together, there is a certain margin in each unit to meet the breakdown, if they are worked under their full possible load.

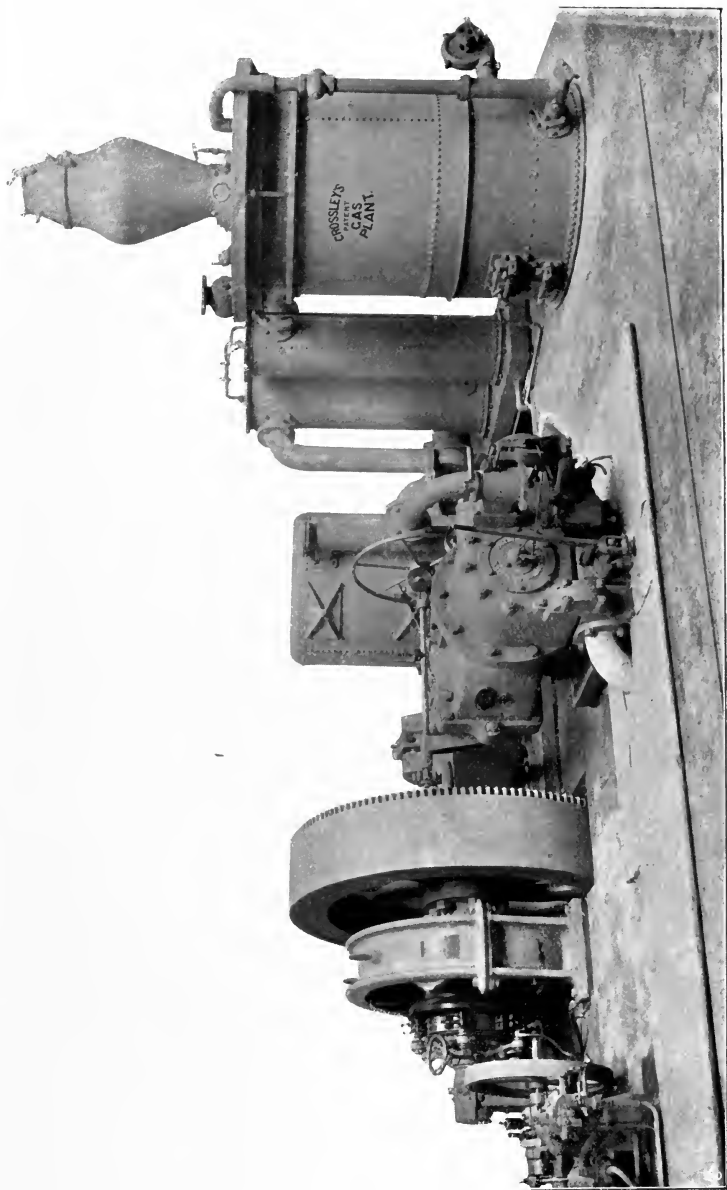

PLATE 11.—Suction Producer Plant, Gas Engine, and Dynamo complete, by Messrs. Crossley Bros., as arranged in the Calcutta Electricity Generating Station.

[To face p. 208.]

CHAPTER V

DISTRIBUTION OF POWER BY ELECTRICITY

It was explained in Chapter I. that the power in any electric circuit is measured by the product of the two factors, the pressure and the current passing in the circuit, with the qualification, in the case of alternating currents, that the difference in time between the current and the pressure which creates it should be taken account of in the power factor. It will, perhaps, be as well to explain that this rule holds good for every case where power enters. Thus, the electrical energy taken by an incandescent lamp, by an arc lamp, or by a motor, is measured by the product of the pressure at the terminals of the lamp or motor while the current is passing, multiplied by the current passing through the lamp or motor at any instant, the product being multiplied by the power factor where the current is alternating; and the electrical energy may at all times be converted into the equivalent mechanical energy by dividing the product by 746, this being the number of watts per horse-power; that is to say, the rate at which energy is being expended in lamps or motors or cables, is measured as above. Further, it should be mentioned that every apparatus that is engaged in transmitting the energy, or converting it from one form to another, takes toll of the energy. Thus the energy, in the form of heat that is delivered to the water in the steam boiler, is not the whole of the energy liberated by the combustion of the coal in the boiler furnace. Again, the energy delivered at the crankshaft of the steam engine or the shaft of the steam turbine is not the whole of the energy either that was delivered to the water, or that was present in the steam which entered the steam cylinder or turbine chamber. Again, the mechanical energy delivered by the steam motor to the electric generator does not all appear as electrical energy at the terminals of the generator. The generator makes a charge varying from seven per cent. to twenty per cent. for converting the mechanical to electrical energy. The cables through which the currents pass to the lamps or motors, again, make their charge for transmitting the

current, the charge being measured in this case by the product of the *fall of pressure* between the terminals of the generator and the terminals of the lamp, motor, distributing point, etc., multiplied by the current passing through the cables. Thus, if current is delivered at the terminals of the generator at a pressure of 550 volts, and the pressure at a distributing point within the mine, say, at the pit bottom, or at a point farther in-by, is only 500 volts, the cables will have made a charge upon the pressure of 50 volts for transmitting the power through them. If the current transmitted is 100 amps., the total charge made by the cables is 5000 watts, or about 6.6 H.P. Further, it should be understood that there is a continual fall of pressure from the terminals of the generator outwards, whenever any current is passing, and that the fall will be proportional to the product of the current passing, into the resistance of the cables, or other conductors through which it passes. Thus there will be a small fall of pressure between the terminals of the generator and the switchboard, to be presently described. There will be a further fall of pressure between the main switchboard in the generator house and the switchboard or distributing arrangement at the pit bottom, and a further fall of pressure between the pit bottom and any distributing point, say, one near the face for the supply of coal-cutting machines. There is a continual fall of pressure through any apparatus that is using the current, and always in the same proportion, bearing in mind that the current and pressure to be employed in calculations of this kind for alternating currents are the *virtual* or *effective* volts and ampères. Further, it is well to note that the fall in pressure at any point, such as the distributing point mentioned, or the terminals of a lamp or motor, vary directly in accordance with the formula, $E = CR$, E being the fall in pressure, C the current passing, and R the resistance between the terminals of the generator, or any other point taken as a starting-point, such as the main switchboard and the terminals of the apparatus. This is a very important matter in connection with the use of electrical apparatus, and the size of the cables required. Incandescent lamps, for instance, which are supplied from cables that are also supplying motors, or other current users, will have their light increased or decreased, according as the other apparatus are taking less or more current, and in the case of arc lamps it is sometimes difficult to keep them working if the pressure varies much at their terminals. To take an instance. Suppose a pair of cables for continuous current to be fixed between the main switchboard and the pit bottom, and to have a resistance of 0.1 ohm, and suppose the pressure at the switchboard to be 550 volts. Suppose, also, that a group of lamps of any kind are taking current from these cables in the neighbourhood of the pit bottom, and that a haulage motor is also taking current from it, and that the haulage motor when at work takes a

current from 100 to 400 amps. When the haulage motor is standing, supposing, for the moment, that no other apparatus is taking current except the lamps, and that they are only taking a small current, the pressure at the terminals of the series of lamps will be 550 volts, or thereabouts. When the haulage motor is started, and is taking its 400 amps., the pressure at the terminals of the cables at the pit bottom will drop to 510 volts, and will then, as the motor gets hold of its load, rise to 520, 530, and 540 volts. This means that the pressure at the terminals of the series of lamps, and at those of each individual lamp, will fall and rise in the same ratio. With the ordinary carbon incandescent lamp this only means that the light will vary, and probably the lamp filament will not last as long as if the pressure was always constant. With arc lamps or Nernst lamps it may mean that the lamps will go out, unless special provision has been made to compensate for these variations.

The author has thought it wise, in commencing this chapter, to go rather fully into this question, because it is of such great importance, in the matter of electrical distribution, to bear in mind that pressures vary in the manner described. He has also illustrated the matter by reference to continuous currents because it is simpler; but the same thing rules with alternating currents, bearing in mind what has been explained about the pressures to be used, and also, as will be explained in Chapter VI., that motors, when they start, take large currents, and when they have got hold of their load, take comparatively smaller currents, and so on.

Conductors for Electric Light and Power Distribution

The conductors for distributing current for light and power are almost universally of copper. Iron has been employed to a very small extent in the form of old wire ropes by Mr. Arthur Sopwith and others, in the early days of electric lighting in mines, but though Mr. Sopwith achieved very good results, it is hardly a satisfactory arrangement. In the first place, iron and steel have from six to seven times the electrical resistance of copper, which means that the conductors employed have to be six or seven times as heavy, and as large in sectional area; and, in addition to this, old iron or steel wire ropes have to be very much heavier and larger in every way than an iron conductor would be under ordinary circumstances, because the old rope is really a mass of broken iron wires held together by the construction of the rope, in which conduction takes place very often between the surfaces of the broken wires, the wires themselves being oxidized or covered with grease. Hence, when large currents come

to be dealt with, a limit is soon reached, beyond which, if it were advisable for other reasons to employ old wire ropes, their size becomes utterly unmanageable. Aluminium is also gradually coming to the front, but it is hardly yet in that form in which it could be recommended for mining work. When it is in a really practical condition it will be cheaper than copper, and probably, as the development of its manufacture increases, it will continue to become cheaper. The specific gravity of aluminium is less than one-third that of copper, while its conductivity is about as 3 to 5 compared with copper. Its price ranges from three to four times that of copper, according to the price of the latter at the moment, so that on the whole, taking all points into consideration, it would be cheaper even at its present price; but there is an element of uncertainty about it still. The metal itself is not yet thoroughly understood. Aluminium has properties quite different to those of other metals. The question of jointing is a very troublesome one. So far as the author is aware, there is no aluminium joint on the market that can be thoroughly recommended for use about mines. The best form of joint he knows of consists of a sleeve, which is slipped over the two ends of the wire to be jointed, and squeezed down upon both of them. Soldering does not appear to be practicable. There is also an element of uncertainty as to the behaviour of aluminium in the open, in the presence of the atmosphere, and any gases there may be in it. In America several attempts have been made to use aluminium conductors for overhead cross-country transmission lines, with varying success.

Overhead Conductors

Where a group of mines are supplied with current from a single generating station, it is perfectly practicable and legitimate to employ naked copper conductors, carried overhead between the generating station and the principal distributing points, such as the sub-stations at the different mines. The copper conductors that are employed for this work are sometimes solid, but more frequently stranded. The limit to the size of a solid copper conductor that can be handled comfortably is about 0.5 of an inch in diameter. For the same reason that insulated copper conductors are stranded after a certain size is reached, overhead conductors are also more conveniently stranded. A stranded conductor is very much more flexible, and more easily handled in every way, than a solid conductor of the same sectional area. On the other hand, a stranded conductor presents a very much larger surface to the action of the oxygen of the atmosphere, and therefore will probably not last as

long where there is much smoke, and where, as usually happens with smoke, there is sulphuric acid in the atmosphere. For these reasons solid conductors are employed in manufacturing districts, while stranded conductors may be employed in country districts. Overhead conductors are supported by porcelain insulators, and these are now usually of what is known as the triple petticoat form shown

HIGH TENSION INSULATORS

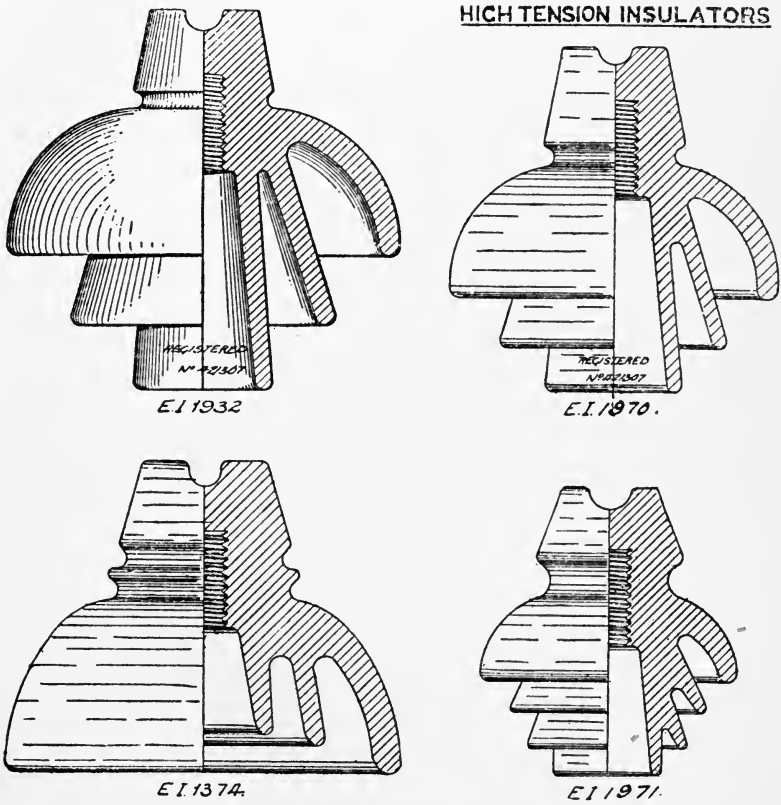

Fig. 90.—Various Forms of Triple Petticoat Insulators made by Messrs. Buller. It will be noticed that in all of them the Surface over which the Leakage Current must pass is made as long as possible.

in Fig. 90. This form of insulator, which has been developed principally in America, is made very strong, of a very high insulation resistance, a very high resistance to sparking through the substance of the insulator; and the surface, as will be seen, is so arranged that any leakage current has a very long path to pass over between the

conductor and the bolt supporting the insulator. Considerable difference of opinion exists among American engineers, who have had the largest experience in overhead work of this kind, as to the material of which the supporting bolt of the insulator should be

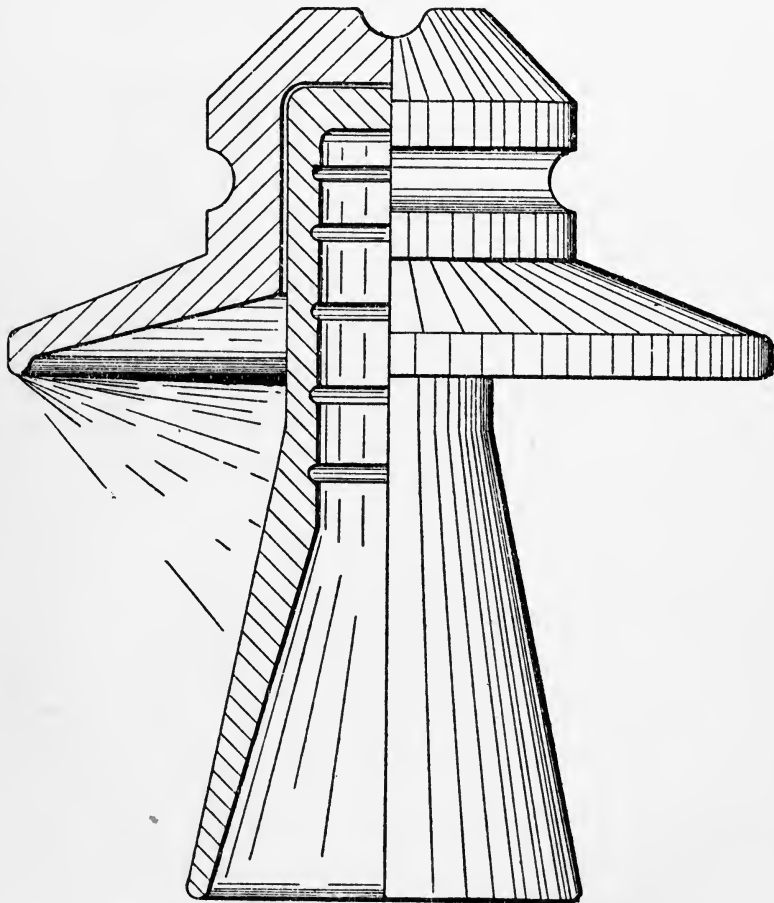

FIG. 91.—Special Form of High Tension Insulator made by Messrs. Buller. It will carry Wires either in the Groove on the Top or in that on the Side.

made. Conditions of strength point to iron or steel, properly galvanized, as the best material, and this is the substance employed for the insulator bolts of telephone and telegraph lines. But other conditions in America have led to the adoption of creosoted wooden

insulator bolts, these being said to give a higher insulation resistance, and to stand climatic and other influences better than iron. In this country iron or steel is generally employed, and the insulator is supported by its bolt upon brackets or arms, carried by poles, fixed in any convenient position. The poles may be of wood, and should then be creosoted, the insulators being supported upon creosoted arms bolted to the poles; or the poles may be of iron, which, again, may consist of latticework, similar to that employed in some of the modern pit headstocks, and in some of the railway signal posts; or they may consist simply of tubes made in definite lengths, and arranged to fix one on top of the other, the smaller one in each case fitting into a socket in the top of the larger one. It is best also, where conductors cross public roads, or where they would be liable to cause damage if they fall, to protect them by guards of some kind placed under the wires. There are several forms of guards; one consists of an iron strap bent round the insulator and bolted to the pole above and below, so that if the conductor leaves its insulator, or if it becomes slack, in place of falling, it is supported by the iron strap. Another arrangement is, iron wires are stretched between the poles, with connecting wires crossing them, forming a kind of open trough or cradle. If the conductors come away from their insulators, they are caught by the cradle. There is another danger with naked overhead conductors that must be provided for, viz. the possibility of mischievous boys climbing the poles and either getting shocks from the conductors, or placing pieces of metal between the conductors for the purpose of seeing the arc that is formed. It is not easy to provide against this, but possibly the best method is a substantial wrapping of barbed wire for a certain distance above the ground, or provision of spiked rings, something after the pattern of a *cheval de frise*. Probably a vigorous application of the police court would be the best preventative. It is also necessary that any conductors about the poles, including the poles themselves if they are of iron, should be well earthed. In some cases earthing arms are provided, consisting of iron arms or brackets connected to earth, and arranged to catch a falling conductor, and therefore, presumably, putting the conductor to earth, and rendering it dead immediately it touches the arm.

Insulated Conductors

There are four substances employed for the insulation of conductors—gutta percha, indiarubber, bitumen, and yarn fibre, or paper, the latter substances being impregnated in resinous oils. All of the insulating substances are hydrocarbons, and they will all, if provided

with a sufficient quantity of heat, become gases, and will then behave very much in the same manner as the explosive gas given off in a coal-mine. If a light be brought to a mixture of the gas, formed from the insulating material, and air, when they are in certain proportions, an explosion will follow. This has been the cause of several of the explosions that have taken place in connection with the underground conductors in the streets of towns, some of which have been erroneously laid at the door of the illuminating gas, which is carried in pipes near the conductors. Gutta percha is hardly ever used for conductors for light and power, because its melting-point is so low, and it softens at such a low temperature that the conductor is easily thrown out of the centre of the insulating envelope, and the insulation on that side becomes very much reduced. For wires, however, for signals and telephones, especially where wet is always present, and where there is no light, as in mine shafts, gutta percha is the very best material that can be employed. For small conductors, also, for electric lighting work, it might be employed with care under similar conditions. Gutta percha is almost indestructible under water when protected from light. As with so many other substances, however, the cost of gutta percha has increased during the last twenty years, and there are many substitutes on the market, containing only a comparatively small proportion of gutta percha, and these substances have not the properties of the pure material. It should be noted that if gutta percha is employed as an insulator, the thickness of the insulation should be as great as possible. With very thin coatings of gutta percha, even when the substance is pure, water, such as is found in most pit shafts, will find its way through.

Indiarubber is the substance that bears probably the best name for the insulation of conductors for mining work, but it is on the condition that there is a very substantial thickness of the rubber outside of the conductor, that the rubber is properly laid on, and that it consists of proper materials. Pure rubber does not stand wet, and it is acted upon by copper, therefore it is usual, where the rubber will be exposed to wet, to submit it to a process known as vulcanizing, in which a certain quantity of sulphur is mixed with the rubber, the compound being baked at a certain temperature after it has been laid around the conductor. In practice, rubber-covered cables are constructed as follows. The outer conductors of the strand are tinned, and the tinning should be very carefully carried out, as where this is not done the copper will be brought into contact with the rubber, and deterioration will set in. Next to the conductors are placed two wrappings of pure rubber strip, laid on transversely and in opposite directions, so that the joints of the strips cross. Outside of the pure rubber is placed a layer of what is known as "intermediate," consisting of rubber to which has been added a

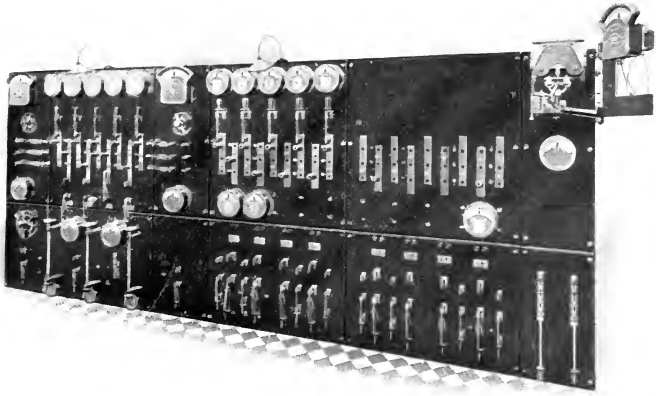

PLATE 12A.—Main Switch Board for Continuous Currents, made by Messrs. Reyrolle, for Mining Work.

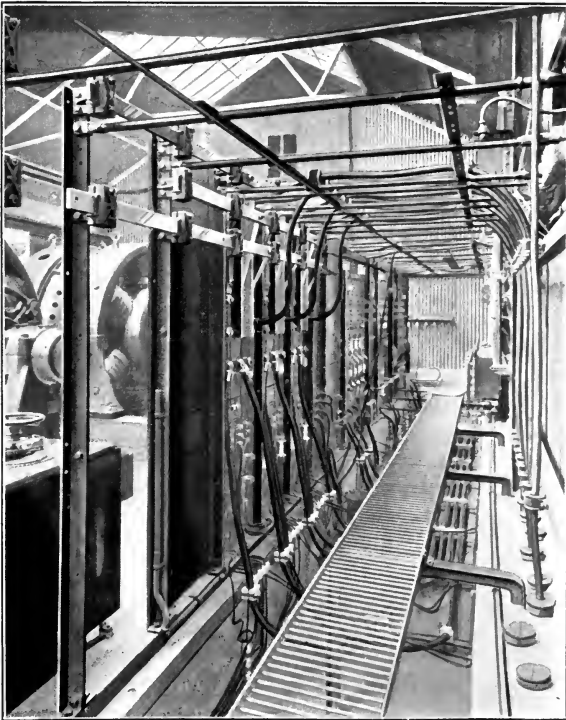

PLATE 12B.—Back of Main Switch Board shown in Plate 12A, made by Messrs. Reyrolle. It will be noticed that there is plenty of room for a man to work without danger.

certain quantity of a salt containing sulphur, such as the sulphide of antimony. Outside of the intermediate is placed another coating called "jacket," consisting of vulcanized rubber. Intermediate and jacket are placed on the conductor longitudinally in two strips, which are pressed round the conductor, cut off, and jointed by one machine. The conductor that is being insulated passes through the different machines in succession. It receives one lap of rubber in one machine, a second lap in a second machine, intermediate in a third machine, and jacket in a fourth, emerging from the last machine completely insulated, except for the baking process and the braiding, etc. After the rubber has been placed on the cable, the coils of cable are placed in a drum, which is heated for several hours, this welding the three coverings, the outer rubber, the intermediate, and the jacket, into one homogeneous envelope surrounding the conductor. After baking, the cable is usually taped, and sometimes braided, sometimes armoured, sometimes covered with lead, sometimes covered with lead and then armoured. There are two great difficulties about the employment of rubber insulation. All the gums of which rubber and the other insulating substances are composed, oxidize freely if exposed to air or moisture, and this leads to the gradual disintegration of the rubber, and the gradual penetration of the moisture, if present, to the conductor, the insulation being destroyed in the process. This difficulty is overcome by having the rubber of considerable thickness; the author's view is that not less than one-tenth of an inch radial thickness should be employed, and he would prefer to have one-eighth of an inch, or more. But here comes in the other difficulty—rubber is very expensive; that is to say, good rubber is. There are two principal kinds of rubber on the market, known respectively as "Para" and West African. The distinction will probably very soon disappear, as rubber is being planted in Ceylon and in various other places, and there are very good accounts of the quality and quantity of the new rubber produced. At the present time, however, the bulk of West African rubber is very inferior, and is worth on the market only about one-fifth that of Para. Para rubber is grown in the district known by that name in the neighbourhood of the River Amazon, and it is not only very much better in quality when produced, but the natives of the district have a method of preparing it, after it is collected from the trees, which kills the parasite that is present, and which, if not destroyed, disintegrates the rubber at a later date. The rubber insulation of all cables employed for electric light and power distribution should consist of at least thirty per cent. of Para. West African rubber, however, is made up to look exactly like Para, is employed for insulating cables, and is made to stand all the tests to which electrical engineers are

at present able to submit it, equally as well as Para, but the useful life of the West African rubber-covered cable is only a fraction of that of the cable with the percentage of Para rubber mentioned.

Bitumen-covered Cables

The high cost of rubber has led to the adoption of cheaper substances, of which bitumen is the one that has been most largely employed in mines. Bitumen is a substance known commonly as pitch, which is found naturally in the pitch lakes of Trinidad and other places. Its insulation resistance is only a fraction of that of rubber, but it is very much cheaper, and it has done very good service. The bitumen is first purified. In its natural state it contains a quantity of dirt and foreign matter which would prevent its being worked, and which also would be fatal to its insulation. The impurities, dirt, etc., are removed by heating and straining, and the substance is then used for insulating cables in three principal forms. Messrs. Callender make two forms of insulators, one consisting of paper, or spun jute fibre, laid over the insulator, and then thoroughly impregnated with bitumen and oil specially prepared for the purpose, a lead sheath being placed over the insulator under hydraulic pressure. They also insulate cables by laying what they call a separator of yarn or paper directly over the conductor, the wires of which have been carefully tinned, and outside of the separator a tube of vulcanized bitumen is laid on, the substance being forced down on to the cable, through a dye, as the cable passes through the machine. There is also another method employed by the St. Helens Cable Co., who insulate cables with a substance they have called "dialite," consisting of bitumen prepared with certain other substances, formed into sheets, cut into strips, and laid on the cables in the same manner as the pure rubber strip described in connection with rubber cables. The dialite cables are exposed to a certain temperature for a certain time after the insulator has been laid on the conductor, the process being called vulcanizing, and causing a welding together of the layers of the dialite, and this forming into one homogeneous envelope, as with the rubber cables.

It is claimed that dialite stands a higher temperature than ordinary vulcanized bitumen, and that it will withstand oxidation and the action of the salts, that are so frequently found in the water in pit shafts, better than bitumen.

All three forms of cable are sometimes armoured, the armouring being sometimes of wire, one or two layers, sometimes of steel tapes, one or two layers, and they are sometimes simply braided. Messrs. Callender also provide a particular form of armour, known as the

"locked coil." It is taken from the locked coil wire rope that has been upon the market for some years, which is well known to mining engineers, in which the outer strands are formed of a particular section arranged to dovetail into each other, and to form together a complete cylindrical envelope.

Paper and Yarn covered Cables

One form of paper and yarn covered cables has already been described, that by Messrs. Callender. Paper, yarn, cotton, and similar substances have all a very high insulation resistance when absolutely void of moisture. Hence they form very good and very cheap insulating substances, providing that the moisture can be kept out of them, and a number of forms of cable have been worked out on these lines. The conductor is covered in some cases with strips of paper laid on transversely, and so that the joints cross, sometimes with yarn laid on in a similar manner. The yarn, or the paper, first has all its moisture thoroughly extracted from its pores, and it is then thoroughly impregnated with hydrocarbon oils under pressure, the whole being drawn into a lead tube. The *rationale* of the arrangement is, as long as the insulating substance has its pores filled with the insulating oil, the insulation will be good, but if the paper or yarn is exposed to the atmosphere, oxidation immediately commences and, in addition, moisture penetrates, the insulation being very quickly destroyed, hence the use of the lead tube for keeping the moisture out. The lead tube is generally formed directly on the cable, the cable passing through the die arranged for the purpose. In some cases, however, the insulated conductor is drawn through a tube already made, and the tube is squeezed down on to the insulating material by hydraulic pressure. Messrs. Glover also have adopted another method of applying the insulator. They prepare a stiff paper cut into strips and impregnated with an insulating substance they have called "diatrine," which imparts a sticky surface to the paper. The paper is laid on diagonally, as already described, the diatrine on the surface of the paper causing the successive layers to adhere together, and the lead tube is then formed on the insulated cable.

A variation of the lead tube protecting the insulating material is a tube of bitumen, which has been employed both by Messrs. Glover and Messrs. Callender.

The great merit of the paper or yarn covered cable is its greater cheapness. It also has a comparatively high resistance to sparking. The substances employed, however, should be, with paper at any rate, good tough fibrous manilla, and it should be thoroughly well dried before applying, as explained. There is the same possibility of

failure with paper or yarn covered cables as with rubber covered, if either the paper or yarn is poor. If not of the best quality it easily rots, or is partially destroyed in the process of manufacture, and if the impregnating oils are impure, or contain any substance which will act deleteriously upon the paper, the same thing results.

In using paper or yarn covered cables, the ends must never be allowed to be open to the atmosphere, otherwise moisture, which is always present in the atmosphere, will gradually creep into the cable, and will destroy the insulation. The author has been informed also, by a cable-maker of experience, of a case where a paper-covered cable was suspended in the shaft, and where the lead covering burst near the bottom, in his opinion owing to the pressure of the oil, etc., above. The reply to this, of course, is that a stronger lead covering was necessary.

Paper-covered cables are sometimes covered with armour, one or two layers of wire or steel tapes, and sometimes merely braided.

Fireproof Covering for Cables

One of the troubles in connection with cables is, if a fall of roof occurs, the cables being broken, and the bare ends lying together, so that a spark followed by an arc passes between them, the heat generated by the arc ignites the insulating envelope of the cable, and this may lead to other very serious results. The same thing may and has happened, where a switch has been allowed to form an arc when opened, or when arcs have been set up between parts of a switchboard, between which considerable difference of pressure exists, owing to the deposit of coal or other dust. In all of these cases the heat, generated by the arc being at an enormous temperature, ignites any inflammable material near it. To meet this, Messrs. Glover and Messrs. Callender have introduced a covering for their cables which they claim to be fireproof. There is, of course, no substance that is actually fireproof, but there are substances which ignite with great difficulty, and which, when ignited, only smoulder, and therefore do not communicate combustion readily to adjoining substances, and this is what those firms have provided. After the cable is completed it is covered with a braid of a substance which has a very high ignition point, which is almost non-combustible, and afterwards the finished cable is drawn through a bath of a substance which also has a very high ignition point. The result of this is claimed to very considerably decrease the dangers mentioned above.

The Formation of Stranded Conductors

Conductors are formed into cables by stranding, for convenience in handling. Above No. 12 gauge the conductor becomes stiff and unpliant, unless it is of a very soft kind of copper, which it is not always wise to employ, and in the author's view No. 14 is the largest single wire that should be employed. After that six wires are stranded round a seventh, forming the cables known as 7/16, 7/18, and so on, the stranded form being made in every size right down to small wires. When the size of the wire required with seven conductors for a given total sectional area becomes large, twelve wires are laid on the outside of the seventh, and another set of cables known as 19/16 and 19/18, and so on, are formed. With still larger cables eighteen wires are laid on outside of the nineteenth, and another series known as 37/16, 37/18, and so on, are formed. For still larger, again, twenty-four wires are laid on outside of the eighteenth, and a sixty-one series is formed, and for the largest size thirty wires are laid over the twenty-fourth, and the ninety-one series is formed. In practice cables are made from 3/25 to 3/18, from 7/24 to 7/6, from 19/24 to 19/7, from 37/24 to 37/8, from 61/24 to 61/10, and from 91/18 to 91/11.

Another point that has to be considered in connection with cables is makers' lengths. It will be understood that, while with small-sized cables almost any length can be made, the only difficulty being the question of coiling it on a drum of sufficient size, as the size of the cables becomes larger the weights becomes heavier, and the whole thing becomes more difficult to handle, and therefore only certain lengths can be employed. In laying out cables, therefore, for mines, it is wise to choose those in which makers' lengths will fit in with lengths of a shaft. On no account should there be joints in a shaft if they can possibly be avoided.

Concentric Cables

For convenience in handling, the cables of a two-wire continuous current, and of a three-wire continuous current system are sometimes made into one cable, in the forms known as concentric and triple concentric. In the concentric cable one conductor is made in the ordinary way, stranded as usual, and insulated to its full thickness, the insulator being further protected by braiding or other arrangement. Outside of the insulation of the first conductor, the second conductor is laid usually in one layer, the number of wires in the single layer being the same as the number of wires in the stranded

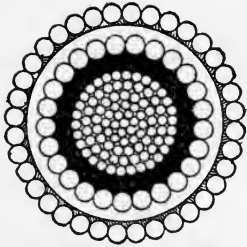

Section of Armoured Lead Sheathed Conductor

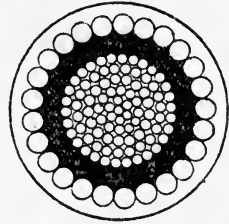

Section of Unarmoured Lead Sheathed Conductor

FIG. 92.—Showing Sections of Messrs. Mavor & Coulson's Concentric Cables with Uninsulated Outers.

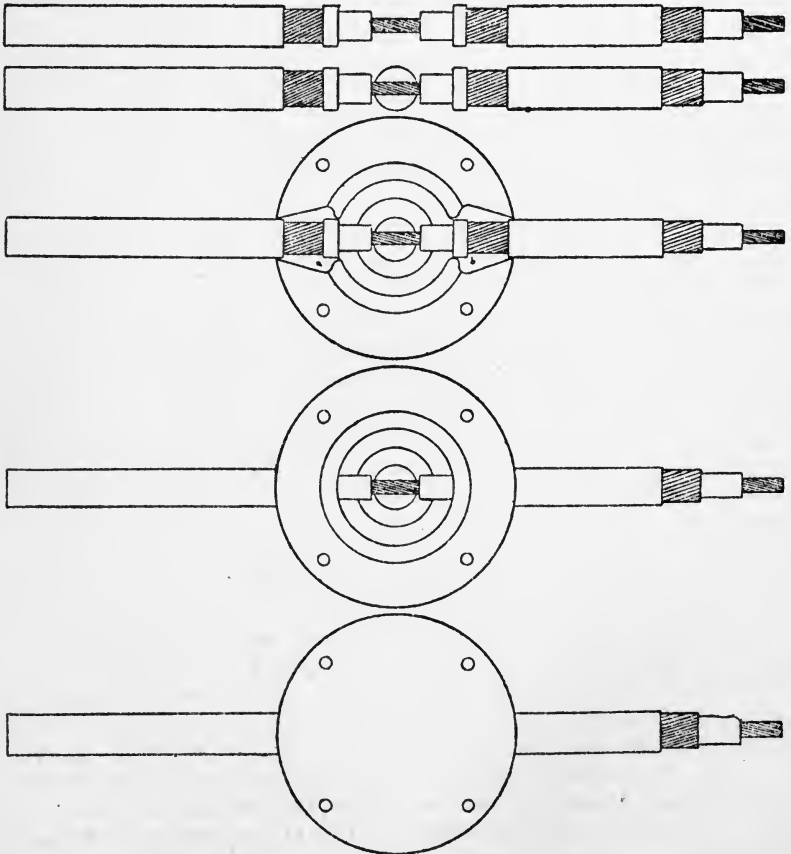

FIG. 93.—Diagrams showing Method of Jointing Messrs. Mavor & Coulson's Concentric Cables.

conductor on the inside, or the total sectional area of the wires forming the outer conductor being equal to the total sectional area of the wires forming the inner conductor. Concentric cables are sometimes built up of copper formed into sections, something on the lines of the locked-coil armour mentioned, or in the form of sectors of cylinders, but in all cases the outer conductor completely surrounds the insulating envelope of the inner conductor, and the sectional area of the two is exactly equal.

Triple concentric cables are for the three-wire system, and in them the outer conductor of a concentric cable is insulated, and a third conductor is laid on outside. With triple concentric cables the outer conductor is usually made the neutral. It is very much smaller than either of the others. It is usual to insulate the outer conductor outside of all, and the completed cable may be armoured with wire or strip steel, or may simply be braided, or, again, may be drawn into a lead tube.

There is a modification of the concentric cable which has been largely used in the Scottish collieries, introduced by Messrs. Mavor & Coulson, in which the outer conductor is uninsulated. The outer conductor consists

partly of galvanized iron wires, partly of a lead tube enclosing the insulating envelope of the inner conductor, and partly of a copper conductor introduced to increase the conductivity. The outer conductor in this case forms the return or negative conductor. It is only employed with continuous currents, and it is claimed that it affords a very efficient protection against shock. All junction boxes, switchboxes, etc., are arranged so that the outer conductor makes good electrical connection with the containing-box. The author's objection to this is, that if a cable is parted, say by a fall of roof, it is difficult to make an efficient connection to the outer conductor. Figs. 92, 93, and 94 show these cables, and the method of jointing them.

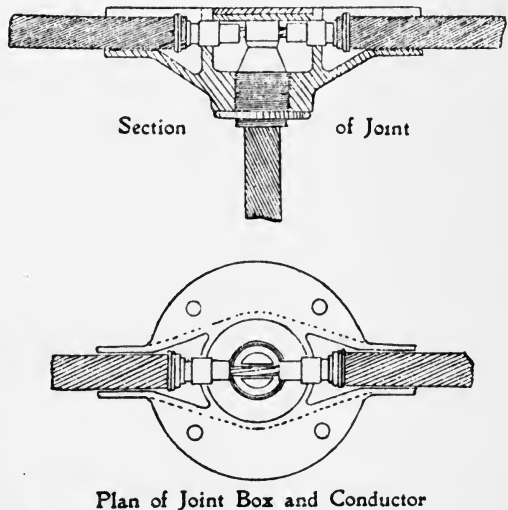

FIG. 94.—Showing Method of connecting a Branch to Messrs. Mavor & Coulson's Concentric Cables.

Three-core Cables

Three-core cables are made for use with three-phase currents. It was explained in Chapter I. that induction takes place between cables in which currents are passing when the strengths of the currents are changing, and in order to neutralize the inductive effects as much as possible, the cables for a three-phase system must be brought as close together as possible, and if they can be twisted round each other, the neutralizing effect will be very much increased. Further, it is absolutely necessary that no single cable carrying an alternating current shall be laid by itself with its own armour, the reason being that the induction taking place in the armour of the cables will be so great as to very seriously affect the efficiency of the system, a large amount of the power delivered to the cable being swallowed up by the induction in the iron armour. Hence a convenient arrangement for three-phase work is, each cable is insulated in the manner intended, the insulation is braided, and the three cables are laid up together, usually round a hemp core, the spaces formed by the stranding of the three cables are filled in with yarn or other substance, and the whole is insulated outside of all, the completed cable then being either armoured, drawn into lead pipe, or simply braided, as may be desired. The armour in this case, or the lead pipe, being common to all the cables, and equidistant from all of them, any inductive effects will be practically neutralized.

For two-phase service, four cables may be made into one, or, as is more frequently done, twin cables are employed, each cable of each twin being separately insulated, and the twins being insulated over all as well. The author does not like twin cables; his experience has been that they are very liable to breakdowns.

Sizes of Cables for Lighting and Power

The sizes of cables for lighting and power services are controlled by three factors—the heating factor, that of waste of power, and drop of pressure. As explained, when a current is passing through a pair or through three cables, as the case may be, to work lamps or motors beyond it, the pressure falls continuously between the two cables as the generator becomes more and more distant, in exact proportion to the formula $E = CR$, where E is the fall of pressure, C is the current passing, and R is the resistance up to the point where the measurement is made. The loss or waste of power in the cables is measured by the formula $W = EC$, where E is the drop in pressure between the two pairs of ends of the cables, and C is the current passing. Evidently the proportion of fall in pressure will be the proportion of

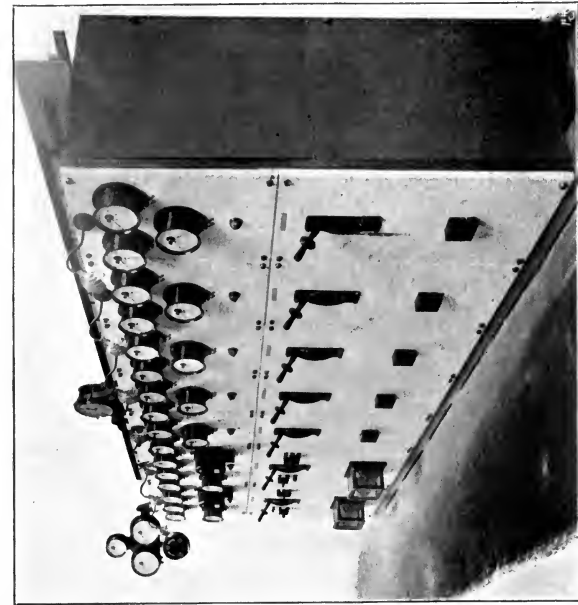

PLATE 13A. — Messrs. Siemens Bros.' Switchboard for Two Generators and Five Distributors.

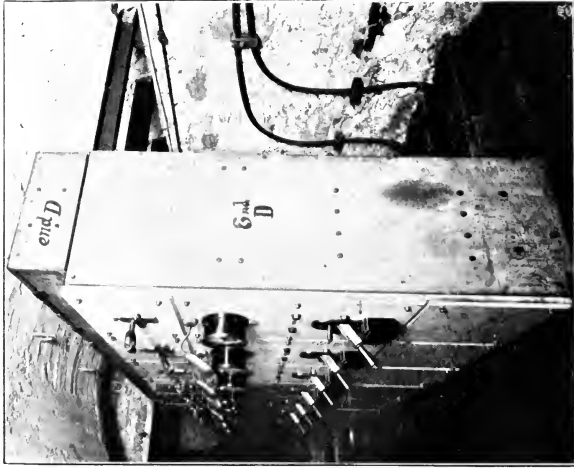

PLATE 13B. — Westinghouse Sub-station for Underground in a Mine.

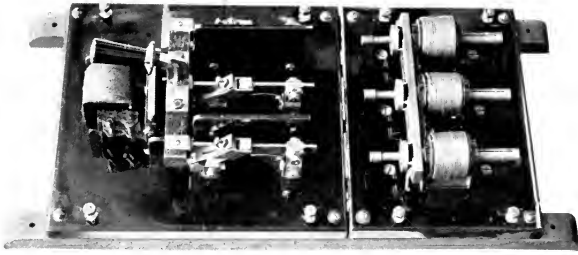

PLATE 13C. — Ferranti Triple-pole Overload, and no Voltage Circuit Breaker. Cover removed.

loss in the cables. Thus, if the pressure at the terminals of the generator is 500 volts, and the pressure at any point—say the pit bottom, or a distributing point further on—through which all the current passes, is 450 volts, the loss in transmission through the cables is ten per cent. Further, this rule applies as the distribution goes on, each branch wastes, or charges upon the power delivered to it, in proportion to the ratio between the fall of pressure and the pressure at the commencement of the branch. The cables, however, are the one portion of the apparatus in which the engineer is master. Within certain wide limits he can make the loss in the cables as little or as great as he chooses. A loss of ten per cent. between the generator and the bulk of the work is commonly accepted as a standard ratio; but this is by no means a hard-and-fast rule, and the proportion of power that may be wasted in the cables depends entirely upon the conditions of the service. Over twenty years ago Lord Kelvin stated the law that for greatest economy the loss in any cables must equal the cost of the horse-power expended in them. This law has since been modified, and the modern reading may be taken to be: the loss in cables in horse-power may be, for economy, such an amount that the annual cost of the horse-power equals the annual cost of the cables it displaces. The first cost of cables is made up of the cost of the copper, and the insulation, and manufacture generally, plus the cost of fixing. The interest on the first three items, added to the cost of maintenance, marks the limiting value to which that of the horse-power may go before its waste becomes uneconomical. It will be seen from this that where power is generated very cheaply indeed, as in a few cases of water power, or by sources of natural gas, by the use of otherwise waste products, etc., it may be economical to waste a very large proportion of the total power generated, because this may enable very much smaller cables to be employed, and the interest and upkeep of them, etc., to be materially decreased.

With continuous-current systems the rule for the calculation of the size of the cables is as follows. Determine the pressure in volts that may be wasted in the particular cables whose size is to be calculated, and then apply the formula—

$$R = E \times \frac{1760}{C \times L}$$

where R is the resistance per mile of the cables, which may be taken from any manufacturer's catalogue, E is the pressure in volts expended in that particular pair of cables, C is the largest current the cables are to transmit, and L is the length of the two cables.

For three-phase cables the formula has to be modified. In the three-phase system each pair of cables with the conductor on the

armature of the generator between them may be considered, for the purposes of distribution, as a separate machine, and the formula then works out for each individual cable—

$$R = E \times \frac{1760 \times 1.71}{2C \times L}$$

L being the resistance of one cable.

For the two-phase system each pair of cables may be considered to be taking half the current, and the calculation may be made for each half, as for continuous currents.

A caution should be given here in connection with two and three phase currents, viz. that the power factor which has been so often referred to, must be taken into account. Current has to be generated, and has to be carried by the cables, in addition to that actually employed in working motors, etc., "idle" current, as it is termed, owing to the lag which was described in Chapter I. This means that the cables have to be made larger than they otherwise would do to allow for the idle current, and in applying the formula for the size of the cable, the power factor taken at 0.8 as a standard, unless there are special reasons for taking it at any other figure, must be applied to the equation.

Heating of Cables

It was explained in Chapter I. that the heat unit is connected with the electrical system of units by the fact that 17.58 watts = 1 B.Th. Unit; that is to say, if an electric current is delivering energy at the rate of 17.58 watts, no matter at what pressure, to any conductor, heat is liberated in the conductor at the rate of 1 unit per minute. It was also explained that the heat liberated is measured by the three formulæ—

$$H = ECt,$$

$$H = C^2Rt,$$

and—

$$H = \frac{E^2t}{R}$$

The last two are the important formulæ for this purpose, and from them it will be seen that the heat liberated in any given cable of a given resistance, in any given time t , varies directly as the square of the current strength in ampères, and also directly as the square of the pressure in volts. The actual quantity of heat liberated in any time in any cable may be found by adding to the above equations

the weight of the cable in pounds, and the specific heat of copper, and the increase of resistance of the copper due to its increased temperature. It was explained in Chapter I. that the resistance of the metals increases with increased temperature in a definite ratio, that of copper being .004 per degree C. When a current is passing through any cable under ordinary working conditions, heat is liberated in the conductor, and a certain portion of it is dissipated through the insulating envelope to the surrounding atmosphere. Under certain conditions, where the current density in the conductor is very low, and where, as in most mines, there is a powerful current of air passing along the surface of the cable, there would be no appreciable rise of temperature in the conductor, and the heat liberated would be measured by the formula—

$$\frac{C^2Rt}{17.58}$$

But where the current density is high, and where the heat has no opportunity of escaping, as where conductors are enclosed, or are coiled on each other, as in dynamo machines, there is a certain definite increase of temperature, and also a certain definite increase of resistance. The importance of this question lies in the fact that conductors for any purpose must not carry more than a certain current density. The insurance companies, the Institute of Electrical Engineers, and others, have settled a standard density of 1000 ampères per square inch of sectional area; but under certain conditions this density may be very greatly exceeded, while under other conditions it is wiser not to come up to it. With overhead conductors which are exposed to the atmosphere, and especially where there are usually fairly strong prevailing winds, the current density may be many times higher than the standard. The question of economy usually dictates a low current density, but there are cases where it may be economical to adopt a high current density, and in those cases it is perfectly safe to do so, providing that the heat which is delivered to the conductor can escape from its surface at such a rate that the mass of the conductor maintains its position inside its insulating envelope.

The heating effect becomes important when either leakage or short circuits take place. The formula—

$$H = \frac{E^2t}{R}$$

shows that, with a given conductor, the heat liberated will depend directly upon the square of the pressure. When a cable is merely carrying a current to an apparatus, or to other cables beyond it, only

a very small pressure is present between its ends ; but when connection is made, say, between the two cables of a continuous current system at the pit bottom, then the whole of the pressure of the system becomes available for delivering heat to the two conductors in the shaft, and, as will be seen, the result will be an enormous increase in the rate at which heat is liberated. A simple calculation shows the difference in the possible heat liberated in a pair of conductors when 50 volts of a total pressure of 500 are expended, and when the whole pressure is expended, in shaft cables. If the cables are short circuited, the full 500 volts are available for delivering heat in the conductors. The increase of heat, if there were no change in the resistance of the conductor or in the pressure, would be as 50^2 to 500^2 , as 25 to 2500 approximately, or the heat liberated would be 100 times as great. The increase of resistance would decrease this proportion, and also the enormous current that would be delivered by the generator would tend to lower the pressure at its terminals, both by lowering the speed of the engine, and by lowering the pressure electrically. But it is easy to see, and a simple calculation will show, that in a pair of cables consisting, say, of 19/16 wires, feeding a 500-volt service, a short circuit at the bottom of a pit 400 yards deep might raise the temperature of the conductor to melting-point, if allowed to operate for a comparatively short time.

Wires and Cables for Connecting to Lamps, etc.

Small wires and small cables for connecting to incandescent, to arc lamps, and to small motors, switches, etc., had better always be insulated with rubber as described on page 216, the rubber being covered outside of all with a substantial coating of jute. If the cables are to be fixed in places where they will be liable to damage, it will be wise to have the rubber as thick as the means will allow. For the inside of engine houses, offices, and similar places, the wires and small cables may be fixed in boxing, consisting of wood, in which grooves are run for the wires to lie, a cover being fixed over them when in place, and the grooves being just large enough to allow the wires to be lightly tapped in. The casing before being used should be thoroughly dried, and should have either several coats of shellac varnish, each coating being well dried before the next is applied, or be protected from moisture in some similar manner. Wires and small cables may also be protected by a conduit which has been introduced from America, called the circular loom conduit. It is made entirely of insulating material with a braiding on the outside, woven in a specially strong manner, the whole thing being steeped in insulating substances, of which finely divided mica forms a part,

and the conduit having considerable strength. This conduit will, in the author's opinion, be found of great service for a great many places about the mine, as well as about pit tops, engine houses, fitting shops, etc. Casing also, made from wood that has been subject to one of the recently introduced fireproofing processes, such as "haskinizing," should answer well.

Cables for Coal-cutting Machines and Moving Motors

The cables employed to follow coal-cutting machines, or pumps on a dip road, present considerable difficulty. In the case of a coal-cutting machine cutting across a coal face of, say, 1000 yards, it is necessary to have a certain length of cable trailing, and it is best that the cables, whether the motor is continuous current or three phase, should be formed into one. The conductors of which the cables are composed should be made very flexible; that is to say, they should be made of a comparatively large number of smaller wires than would be usual if the cable were simply delivering current in the ordinary way. The larger the number of wires of which each conductor is formed, the more flexible will it be, but, on the other hand, the more easily will it be parted if wet penetrates to it. The two or three cables should be laid up together, and they may be held together by a light steel wire armour, or, as the author prefers, a wrapping and a braid of jute, or the plaited leather covering that has been introduced by Messrs. Glover. The gate road connecting boxes for coal-cutting machines should be arranged at as frequent intervals as possible, in order that the trailing cable may be as short as possible; but, on the other hand, this entails carrying the supply cable either up several gate roads, or across the face. No rule can be given applicable to all cases of this kind, the electrician at the colliery must use his own judgment, following the rule given on page 235, to keep the cables out of the way of everything as much as possible.

Fixing Cables in Mines

The most important part of the mine with respect to the fixing of cables is the shaft. Even with small insulated wires such as are employed for signals, the problem of fixing them in the shaft in such a manner that they shall not be damaged by falling mineral, and other substances is by no means an easy one. As the conductors become heavier, as they do with electric light and power services, the

problem becomes more and more difficult, because the weight of the cable itself and the effect upon the elongation of the conductor, and the possible opening of the insulating material comes into play. There is considerable difference of opinion as to whether cables, both in the shaft and on the roads, should be armoured or not. In the author's opinion, which he has published on every possible occasion, and which he has seen no reason to change, armoring is wrong except in the special case of three-core cables for three-phase currents, and then he would only allow a light armour for the purpose of holding the three cables together conveniently, and supporting them. With cables intended for continuous currents he prefers that there should be no armour, and he objects to the use of

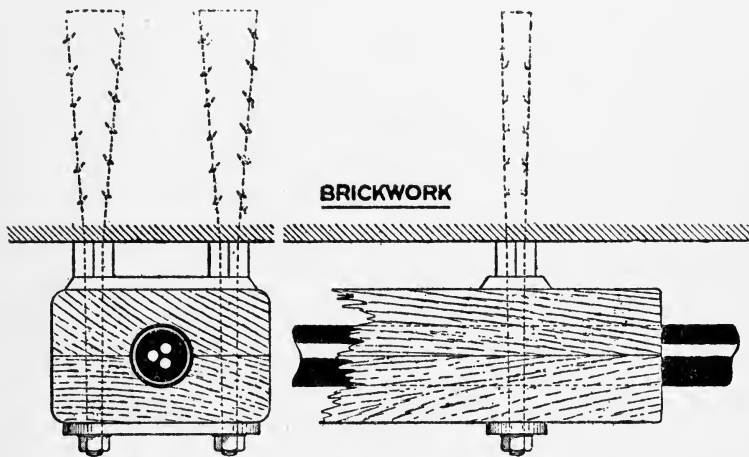

FIG. 95.—Showing Messrs. Callender's Single Cable Cleat for bolting to a Brickwork Shaft. It will be noticed that the Cleat is kept clear of the Brickwork.

any conductor outside of the insulator, and for the reason that it is very difficult, in manufacturing, to avoid straining the insulating material while laying the outer conductor on. With the advance of manufacture this difficulty has been to a large extent overcome, and there is not now the danger there was, of damaging the insulation. But there is still the same danger of damaging the insulation, both in the process of laying the cable, and after the cable is laid, particularly in mines, where cables are necessarily subject to rough usage, the bending, kinking, squeezing, etc., tending to drive the armour or outer conductor through the insulating material. It is as well to remember that if, in the case of an armoured cable, the armour is driven through the insulating material and makes connection with

the copper conductor, the armour itself becomes, to all intents and purposes, the conductor. It is alive and will give shocks if it happens to be the positive conductor. It will also tend to deliver currents to other conductors with which it is in contact, and it will also tend to set up sparking, not only between itself and the other conductors, but between other conductors with which it is in contact at certain points, and conductors with which they are in contact, and from which they may be temporarily disconnected. It is hardly necessary to enlarge upon the danger of this. For fixing cables in a shaft there are broadly four methods.

1. The cable may be suspended from top to bottom of the shaft without any intermediate support. This method may be adopted in shallow mines, and with light conductors, and providing that they are properly insulated at both top and bottom, and that the bottom connection is carefully protected from the lodgment of water and coal-dust. For many cases this method would be very suitable. The

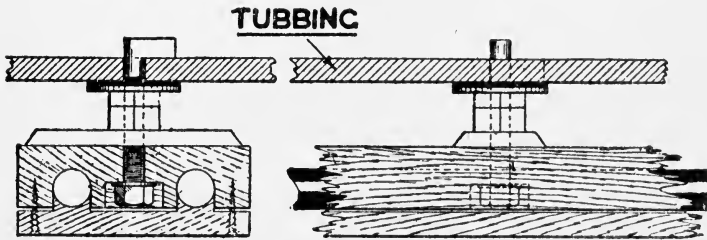

FIG. 96.—Showing Messrs. Callender's Cable Cleat, for two Cables, for bolting to the Brickwork of a Shaft.

great danger of this method is the possibility of the insulating envelope of the cable being damaged by falling coal, and the lodgment of water and coal-dust where the cable is fixed at the bottom, and where it is probably bent, and where the insulating envelope may be strained, the result being that the water may penetrate the insulating envelope.

2. A modification of 1 is, the cables are supported by insulators at the top of the pit, they are stretched from top to bottom in the same manner as in 1, and they are further supported at equal intervals between the top and the bottom by various devices, such as short pieces of wood casing secured to the byatt, with a cover arranged to squeeze the cable into a groove provided for it, or glazed earthenware insulators may be employed, the insulators being made in two halves so as to clasp the cable, the insulators with the cables being supported by brackets secured to the side, or to the byatt.

This method is also open to the objection that the cable may be damaged by falling coal, etc., and each support provides a lodgment for water and coal-dust, and there is the danger of trouble arising at those points. If, however, attention is given to these matters, and the coal-dust is cleaned off at fairly frequent intervals, the danger is minimized, and the results should be, and have been, satisfactory. Figs. 95, 96, and 97 show methods of supporting cables in the shaft by wood cleats, as arranged by Messrs. Callender.

3. In the third method, which in the author's opinion is the best,

provided that it is properly carried out, but which has the usual drawback that it is more expensive, wood boxing is fixed against either the side of the shaft or at the back of the byatts, the boxing being made from substantial planking that has been subject to one of the preservative processes such as haskinizing, the grooves for the cables being made so that the cables themselves have to be tapped gently into the grooves, and are then held by the boxing the whole way down the shaft. The cover of the casing in this case need only be sufficiently strong to prevent falling mineral from knocking it away

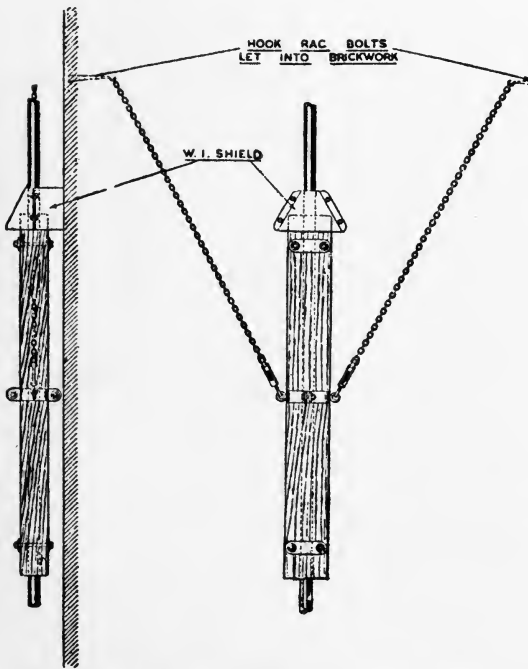

FIG. 97.—Messrs. Callender's Single Cable Cleat, for Mine Shafts, supported by Chains from the Brickwork.

and exposing the cables. One great objection to the use of wood boxing for holding the cables in the shaft is, unless the wood is treated in some way, it, being porous, absorbs water like a sponge, and as it clasps the cable the whole way down, it is in the very best position to deliver the water with any salts it may contain to the insulating envelope, and as the water is always there and always acting, the results are sometimes serious. Haskinising is claimed to

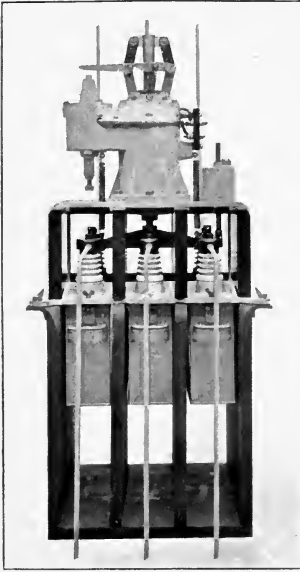

PLATE 14A.—Ferranti 1500 Ohm, 10,000 Volt, Three Phase, Oil Enclosed, Electrically Operated Switch, with Switch closed, but with Case open.

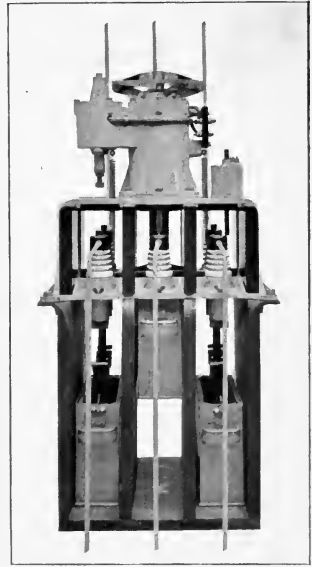

PLATE 14B.—Ferranti 1500 Ohm, 10,000 Volt, Oil Enclosed, Electrically Operated, Three Phase Switch, with Switch open, and with Oil Tanks of two of the Switches lowered.



PLATE 14C.—Gas Proof, Oil Enclosed, Three Phase Switch.



PLATE 14D.—Ferranti Gas Proof, Three Phase Mining Switch. The Cover is up, to show the Contacts inside.

prevent all this. The wood before being subjected to the process is thoroughly dried, all the sap removed, and all moisture, and the pores filled with a substance which it is claimed increases the insulating value of the wood, renders it non-combustible, and impervious to moisture. A cheaper form of this method is, boxing is made from substantial planking as before, it is thoroughly dried—this is the most important point in the whole matter—and it is treated before being placed in the shaft to two or more coatings of Stockholm tar, the treatment with tar being repeated after the cables are fixed and at intervals after they have been put into service. This method, the author understands, has also met with considerable success.

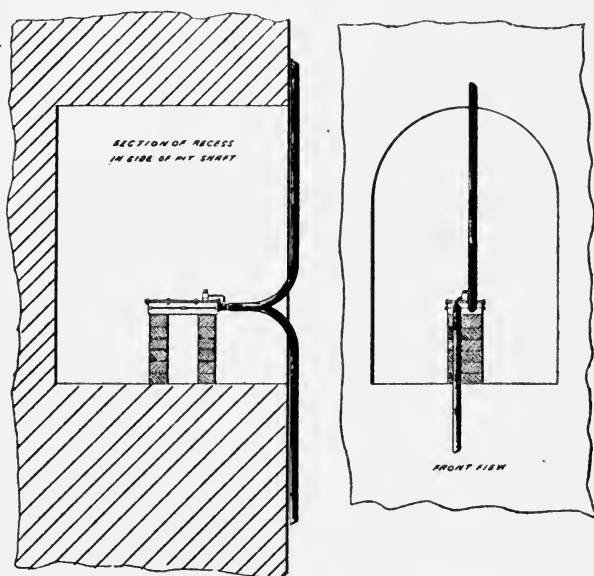

FIG. 98.—Showing Messrs. Glover's Method of jointing a Cable in a Shaft. A Recess is cut in the Side of the Shaft and the Joint made there.

4. The fourth method is, iron pipes are fixed in the shaft, secured by brackets, or in any convenient way, to the sides or to the byatts, and the cables are run inside them. With this method it is also sometimes arranged to lay the cables in sections in the shaft, of any convenient length, providing junction boxes consisting of cast iron, into which the pipes screw, and which have covers arranged to fix on their fronts, so as to exclude moisture. If iron pipes are used, probably this is as good a method as can be adopted, as the junction

boxes provide means of testing the different sections in case of faults in the cables; but in the author's view it is wrong to conceal your cables inside iron pipes. Cables should always be either visible, or easily got at for inspection. Further, in his opinion it would probably be exceedingly difficult to ensure that the junction boxes shall always be watertight. In his experience, making a joint in a cable or wire in a shaft so that moisture is excluded is absolutely impossible. He has never yet seen any shaft in which cables can be fixed in which moisture was not present; while in the great majority of mine shafts water is fairly abundant, to such an extent that it is very difficult indeed to keep it from the hands, and from any conductor that one may be handling in the shaft. As explained above, with alternating currents, if iron pipes are employed, all the cables must be enclosed in the one pipe.

With three-phase cables the author prefers the three-core cable with a light armour, sufficient to take the weight of the cable to a certain extent, and he would prefer its being fixed in wood boxing, as explained. Fig. 98 shows the method adopted by Messrs. Glover for jointing a cable in a shaft.

Fixing Wires on Engine Roads, etc.

For engine roads again there are several methods. The use of iron pipes arranged in a somewhat similar manner to those explained for the shaft have been used and advocated, the pipes being placed on the floor of the mine. The author's objection to this is the same as in the case of the shaft cables: you cannot see what is happening to your cables, and, in addition, as mining engineers know, your pipe, if laid on the ground, is apt to disappear, and is subject to the working of the mine, causing breaks at junctions, etc., and water may get into pipes, will run to the lowest point, and will there surely cause trouble. Another method is to lay the cables in wood troughing, and to fill the troughing in with melted pitch. Where it can be adopted, this plan is a very good one, and it does not matter what the wood troughing is made of, providing there is plenty of space for pitching, nor does it matter if the wood troughing disappears, as the pitch tube which is formed is a very good protection indeed for the insulating envelope of the cables. Pitch has the peculiar property—possessed also by ice—of sealing up any cracks or openings that are formed, say, by the working of the mine, so that it should be difficult for moisture to penetrate to the cable in any appreciable quantities. The difficulty of applying this method is, that in many parts of coal mines it is not possible to apply sufficient heat to melt the pitch. Another method is to support the cables on glazed

earthenware insulators, which are fixed to the props, or in any convenient manner, the cables being tied to the insulators with yarn or similar material. This, in the author's opinion, is also a very good method of fixing cables on main roads, and places where they are not very liable to accident. The insulators need not be at all elaborate. Those described as being employed for terminating iron engine-road signal wires, which have a groove around them, will answer very well, the insulators being merely fixed to the prop by a bolt, and, if necessary, a washer, the cable lying in the groove on the insulator, and being secured there by yarn. In another method, which has a great deal to recommend it, and which is applicable either to main roads or to gate roads, a leather thong is attached to the cable by a loop, and its other end is nailed or bolted to the prop, or any convenient spot. The great advantage claimed for this method is, in case of a fall of roof the leather thong is broken, and the cable falls to the ground, and is only exposed to any crushing action that may take place after the roof has fallen, not to any cutting action such as that by the sharp edge of a piece of rock cutting through the insulating material during the fall. There are modifications of this method that will be obvious, such as supporting the cables by bands of yarn from props or hooks supported by props or beams. In fact, in gate roads, and in the neighbourhoods where the mine is working more or less, almost any method may be employed that will keep the cables apart, out of the way of the mineral waggons, and that will protect them, as far as possible, from falls.

Methods of Distribution

One of the important points for consideration in laying out a power plant for distribution by electricity is, the pressure at which the service shall be worked. It will be understood, from what has been stated, that since the power is measured by the product of the current and the pressure, if the pressure can be increased, the current can be decreased, and by decreasing the current, the size of the cables for the transmission of a given quantity of power may also be decreased. The charge made by cables has been explained as being measured by the formula—

$$W = EC = C^2R = \frac{E^2}{R}$$

From the second of these, C^2R , it will be seen that the charge made by the cables varies directly as their resistance, and as the square of the current they transmit, so that any reduction in the current reduces the charge for the same resistance in the ratio of its square. It will also be seen that with a given resistance the charge varies as the

square of the pressure, the pressure in this case meaning that which is used up in driving the current through the cables. Further, from the formula $E = CR$, it is evident that with a given resistance, the smaller the current, the smaller the pressure required to drive it through. From all these considerations it follows that doubling the pressure not only halves the current, but it allows the cables employed to be made of one quarter the sectional area, or a quarter the weight for a given length. The charge for the passage of the current through any resistance is halved, and doubling the pressure gives double the available pressure for use, with a given percentage of loss; hence the above saving. From this it will be seen what a valuable instrument is placed in the hands of the engineer for distributing power with small outlay, providing that he can increase the pressure as much as he requires. Another point had perhaps better be mentioned here—the effect of distance upon the size of the cables for the transmission of a given power. It was explained in Chapter I. that the resistance of any conductor of a given sectional area varies directly as its length. It follows, therefore, since the charge both upon the initial pressure generated, and upon the power delivered to the cables, depends directly upon the resistance of the cables, that the charge will increase directly as the length of the cables, unless the sectional area of the conductor is increased in the same proportion as its length is increased. That is to say, if power is required at a distance of two miles from the generator, the cables to transmit it with a given loss must be twice the sectional area, and therefore four times the weight of the cables required to transmit the same power to a distance of one mile. Hence the importance of being able to increase the pressure with increased distance, and increased work at a distance will be appreciated. In coal mines, and in metalliferous mines, the two quantities, distance and work to be done at a distance, are constantly increasing. In nearly all cases as the mine develops, the distance over which the mineral has to be hauled, and often that through which the water has to be pumped, increases, while the power for coal-cutting machines, drilling machines, etc., increases, and has to be delivered at greater distances. To meet the increased cost, increased output is resorted to, and this means that increased work has to be done from the increasing distance, leading again to the necessity of high pressures, if economy is to be realized.

The Two-wire System

The simplest of all arrangements for distributing current is that known as the two-wire system, as shown in Fig. 99. It can be used with continuous current machines, and with single-phase alternating

current machines, though the latter are practically barred out for use in mines for the present. With this arrangement two cables are led from each generator to the main switchboard, as will be explained, and two cables are led from the switchboard to each district, or each part of the mine that is to be supplied. Thus two cables would be led out for the supply of the surface motors, if they were all on one side of the generator house, or more than two sets if the generator house was in the middle, and the power required by motors lay round it. If there is more than one seam worked, a pair of cables are, or should be, carried from the main switchboard to each seam. If it be preferred, one pair of cables may be taken right to the bottom seam, and branch cables attached to each seam, but if this plan is adopted, the cables must be taken well in out of the shaft to a dry place before tapping. It is also a feasible and practical arrangement to take a cable of sufficient size to supply current for the two or more seams to the upper seam, and to carry smaller cables from the upper seam to

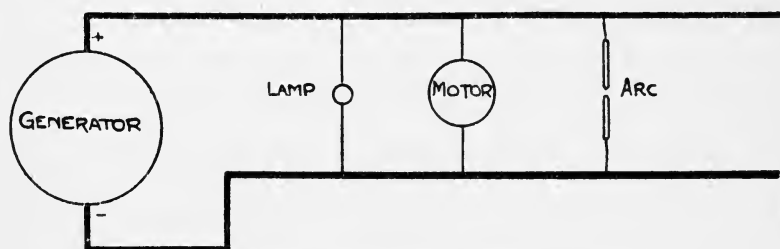

FIG. 99.—Diagram showing Two-wire System of Distribution.

the seams below, the different sections of the cables being made in complete lengths. With metalliferous mines, where a number of levels are worked from the same shaft, and where there is a great deal of water in the shafts, and often on the levels, it is a question for the engineer in charge whether he will run a pair of cables for each level, or whether he will work on what is known as the tree system, taking large cables to the upper level, and gradually tapering off as the mine descends. Both arrangements have their advantages, and if there is a shortness of room in the mine shaft, either in a colliery or a metalliferous mine, the engineer may be obliged to take only one pair of cables down. Whatever the arrangement may be that is made for supplying the different levels, or the different seams, the cables are, or should be taken, to a switchboard, as will be explained, at each seam or level, and from there two cables should be taken along the roads to distributing points, where again fuseboards, or switchboards, or disconnecting arrangements of some kind should be made, and from there pairs of cables carried into each district to be supplied,

and so on. As explained, the pressure at each point in the distribution service will be the generator pressure, less the charge made for the passage of the current through the resistance between it and the point in question. In the author's opinion, this, the simple two-wire system, is by far the best, where continuous currents are employed. The two-wire system can be employed for practically any pressure; for 100 or 110 volts for lighting service, which, as explained in Chapter III., may be provided by a motor generator; for 200, or 220, 440, 500, 550, and 600, these being the limits to which continuous currents have been applied in mining work. The two-wire system may also be employed with high tension single-phase working, where that is used, as say, for lighting, but with the aid of transformers.

The Three-wire System

The three-wire system the author does not recommend for mining work, because, in his opinion, it leads to complications that are better avoided; but, as he understands that it has been employed in certain mines, he thinks it wise to give a description. It is intended to give the advantage of double the pressure in the size of the cables, or nearly so, in a lighting service with lamps made for only half the pressure. Thus, when incandescent lamps were only made for 100 and 110 volts, three-wire systems were worked at 200 and 220 volts. Now that lamps are made for as high as 260 volts, three-wire systems are worked at from 400 up to 520 volts. With the early form of the three-wire system, two generators of the lamp voltage, 100 or 110 in the early days, 200 to 260 volts now, are connected in series, the positive terminal of one dynamo, the negative terminal of the other, being connected to the two main distributing cables, these cables being termed "outers." The junction between the two dynamos is connected to a middle wire, or cable, called the "neutral," and this cable is made very much smaller than either of the others. The outer cables are made of the size they would have had if the combined pressure of the two generators had been employed in the ordinary way, and the neutral cable is made about half the size of one of the outers, so that a considerable saving in copper is effected. Lamps are connected between the positive outer and the neutral, and between the negative outer and the neutral, and when there are an equal number of lamps, or an equal current in each branch, current only passes through that portion of the neutral wire connecting the batches of lamps together, the current passing through the lamps connected to the positive outer, then through the lamps connected to the negative outer, and through the outer to the machines, the neutral wire merely acting as a connection between the negative terminals of

individual lamps in the negative section, and the positive terminals of individual lamps in the negative section. When there is more current passing either in the positive branch or the negative branch, the difference in the current passes through the neutral wire to the joint terminal of the two machines. Fig. 100 shows the connections for this. This was the earliest arrangement of the three-wire system, and it was developed in the case of Manchester into a five-wire system, with four generators connected in series. The five-wire system has been discontinued, and the later practice is to have only one generator furnishing the full pressure, 400 to 520 volts, as may be arranged, the terminals of the generator being connected to the outers, and the neutral wire having no connection except to earth at the generating station, and to the lamps. This arrangement

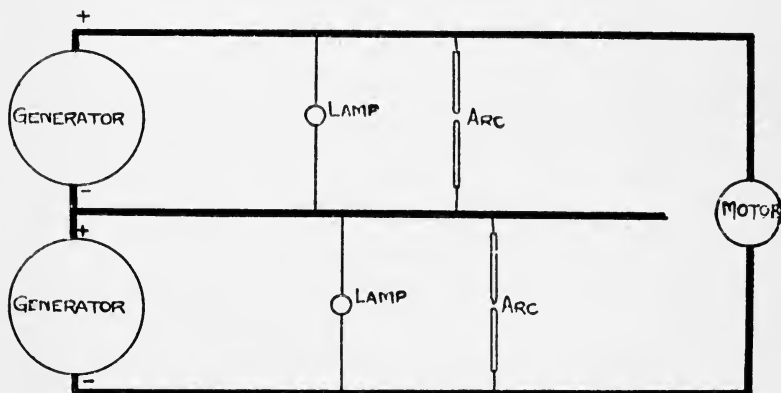

FIG. 100.—Diagram of the Connections for distributing on the Three-wire System with two Generators. Motors are frequently connected across the Outers, Lamps always between one Outer and the Neutral Wire.

necessitates some provision for transferring the work from one branch to the other when more current is being taken by one branch than the other, and for this purpose the balancers described in Chapter IV. are employed. As explained in that chapter, balancers consist of two identically similar machines having the axles of their armatures mechanically connected, and the machines themselves being usually fixed on one bedplate, and they may be arranged to be driven either automatically by the service itself, so that there is an automatic transfer of energy from the side doing less work to that doing the larger amount of work, or they may be driven by an engine. In either case both machines are shunt-wound, and have resistances connected in the circuits of their field magnet coils that can be adjusted at the main switchboard, or at an auxiliary switchboard in

special cases. However the balancers may be driven, the armature of one of the machines is connected across each branch, as shown in Fig. 101, which represents a steam-driven balancer, and when they are not driven by a steam engine, the ends of their field coils are connected to the opposite branch to that to which their arma

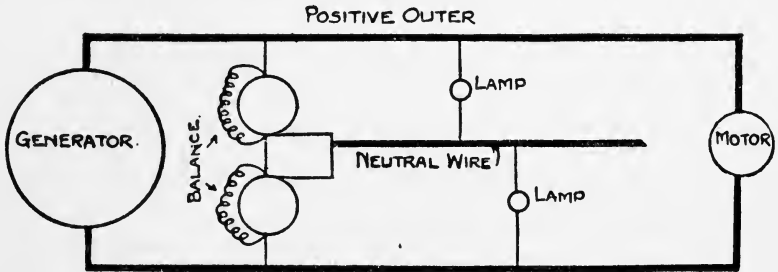

FIG. 101.—Diagram of Connections of a Steam-driven Balancer.

tures are connected. The field coils of the half of the balancer whose armature is connected in the positive branch are connected to the negative outer and the neutral, as shown in Fig. 102. The field coils of the other half of the balancer are connected to the positive outer and the neutral. When one branch takes more current than the other, the pressure between the outer of that branch and

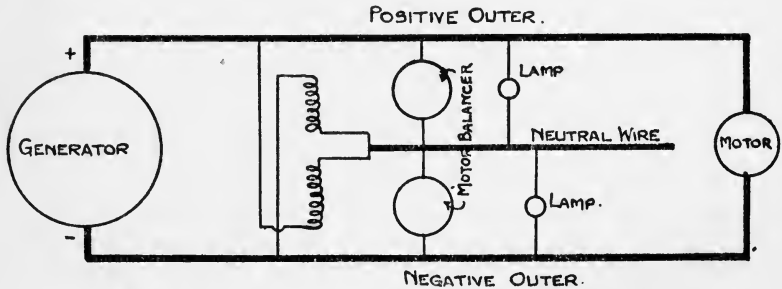

FIG. 102.—Diagram of the Connections of a Motor-driven Balancer. The Field Coils of each Half of the Balancer, it will be seen, take Current from the opposite Half of the System.

the neutral is lowered in consequence of the increased current. As the half of the balancer whose armature is not connected to this branch takes current from it, the current passing in its field coils is reduced, and this leads, as will be explained in Chapter VI., to its running as a motor at a higher speed than it was previously running at, the two machines running simply as motors, but

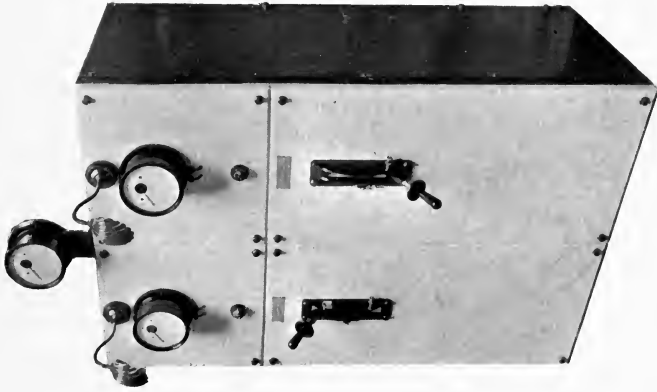

PLATE 15A.—Front View of High Tension Motor Generator Switchboard, for use underground, made by Messrs. Siemens Bros.

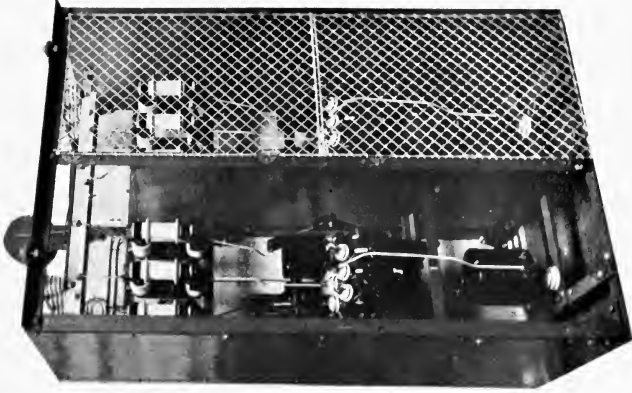

PLATE 15B.—Back View of Messrs. Siemens Bros.' High Tension Motor Generator Switchboard for use in Mines.

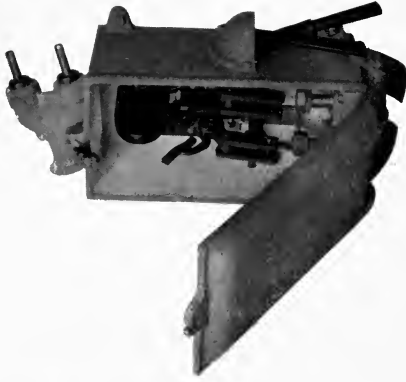

PLATE 15C.—Messrs. Dorman & Smith's Gas Proof and Fool Proof Mining Switch. The Case cannot be opened if the Switch is closed. The connections are led through the Glands shown.

doing no useful work when the balance is even. The machine in the other branch, running faster as a motor, drives the machine in the overloaded branch as a generator, also at a higher speed than when the balance was even, causing it to create an increased pressure, and thus to furnish the increased current required by that branch. When the balancers are steam driven, each is connected in its own branch, each has its own adjustable resistance in the circuit of its field coils. The two are driven at the same speed, but when the engineer-in-charge observes that one branch is taking more current than the other, he increases the excitation of that half of the balancer, thereby increasing its pressure, and providing the additional current required. Modern practice tends towards the steam-driven balancer; it is more under control, and it can be employed, if desired, to take the place of the generator on very light loads. It is a common practice with three-wire distribution, with, say, from 400 to 520 volts between the outers, to supply motors with current from the outers, and lights from each of the branches, the lamps being distributed as evenly as possible, so that there shall be the same number of lamps burning as frequently as possible in each branch.

The Use of the Accumulator as a Balancer

Accumulators have not been much used in mining work, because they are somewhat troublesome, but in the author's opinion they probably will be as time goes on, and he thinks it wise to give particulars of every occasion where they can be of service. They have been used occasionally as balancers on three-wire systems, the accumulator being divided into two batteries, which take the place of the motor generator balancer, the number of cells in each branch of the service being either controlled by hand from the switchboard as the current taken from either side increases or decreases, or being controlled automatically. The accumulator is, of course, being charged with a small current when it is not furnishing any current to either side, and the regulation may be performed either by switching regulating cells in and out in each branch, or by fixing a resistance in each branch in series with the accumulator, and switching a portion of it in and out.

Distribution by Two and Three Phase Currents

Two and three phase currents may be employed for distributing current for light and power, either with low, medium, high, or extra high tensions. Pressures are looked upon by the Home Office as follows:—Up to 250 volts are considered low pressures; between

250 and 650 volts, medium pressures; between 650 and 3000 volts, high pressures; and above 3000, extra high pressures. Two-phase currents are very little employed in mines, but three-phase are, and are being more and more employed. All that is mentioned about three-phase currents applies to two-phase, with the proviso that two-phase currents require four wires, except with the special arrangement mentioned below, while three-phase require only three wires, also except in the case of the special arrangements mentioned below. As explained in Chapter I., the two currents generated by a two-phase machine are provided with their own complete circuits in the machine and outside of it, the two circuits being represented by two distinct pairs of cables, connecting the machine with the lamps or motors. It will be seen that there is a certain disadvantage in this matter with two-phase, since it is possible to make connections between cables belonging to wrong phases, and it is not easy within the mine, unless the cables are very carefully distinguished by being braided in different colours, and then the colours are apt to be extinguished by the all-pervading black of coal-dust, or the dull grey of the metalliferous mine, while with the three-phase service there can be no mistake whatever. The arrangement of the cables of a two-phase service may be modified by making one cable the common return for the two phases, three cables only then being required; but there is still the same danger of connecting lamps, say, between the cables belonging to the two phases, unless some special arrangement is made to prevent it. With three-phase currents, as explained, there are three cables connected to the three terminals of the machine, lamps being connected between either two cables, and finding between them the pressure the service is delivering. There is a modification of the three-phase service, however, that is sometimes advocated, mainly in connection with the star-connected machine. In this arrangement the neutral point of the armature conductors is connected to one cable, and may be arranged for incandescent lamps to be connected between the three ordinary service cables and the neutral cable, the three ordinary service cables being connected to motors. This arrangement is principally of service where the three-phase system is worked at a pressure of 440 volts between the ordinary cables, the pressure between any of these and the neutral cable then being 250 volts, which is nearly the present limiting pressure for incandescent lamps. In the author's opinion, the arrangement is not a wise one. It is only when the special voltage named is used that it assumes any convenience whatever, and it introduces a fourth wire into the system with the complications that it unfortunately brings. In his opinion, everything about a mine should be kept as simple as it is possible.

Three-phase currents are being used in mines for 200 to 220 volts,

also for 440, 500, 550, 600, and up to 3000 volts, the service in the case of these pressures being direct. That is to say, the full pressure, whatever it may be, is delivered by the generators to the switchboard, and from the switchboard to the distributing cables, or feeders, and from them to the lamps and motors. Motors of up to 50 H.P. can be worked with pressures below 650 volts, but above that power the windings and the insulation become difficult with the low pressures, and therefore higher pressures are employed. For the lighting service, as already explained, arc lamps or incandescent lamps may be connected in series between any two of the three cables of the three-phase system, and between each of the pairs of cables of the two-phase system, or between the cables and the neutral; but the author's view is, that it is wiser to employ a motor generator, its motor taking current from the three-phase service, and its generator delivering continuous currents at 100 volts or so for the lighting service. For the power service, the three or the four wires of the three-phase and two-phase systems are taken direct to the motors, with medium and high pressures, through the starting switches, etc., as will be explained in Chapter VI.

Distribution by Two and Three Phase Currents at High Tension and at Extra High Tension

Where high tensions or extra high tensions are employed with two and three phase currents, stationary transformers are employed. The current may be generated at the full pressure, say, at 3000 volts,

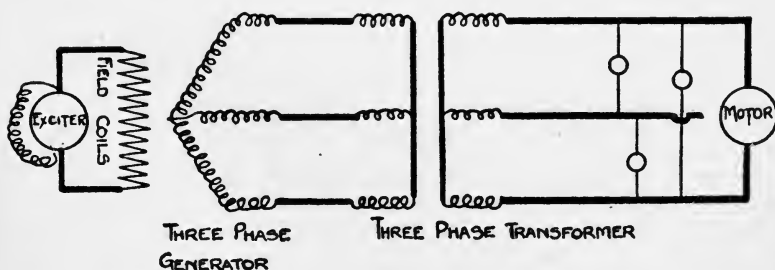

FIG. 103.—Diagram of Connections for Three-phase High Tension Distribution with one Transformer.

or it may be generated at a lower pressure, say, 500 or 550 volts, and transformed up to 3000 volts. In the case of extra high tensions the currents are always generated at a lower pressure than that which is to be employed for transmission, and they are transformed up. As

explained in describing stationary transformers in Chapter IV., the transformer may be employed to increase the pressure delivered by the generator, or to decrease it, or for both. Thus, where power is transmitted over long distances, as where a number of mines are taking power from a waterfall at some distance, it is usual to generate the currents at 500 volts, or thereabouts, to transform them up by stationary transformers at the generating station to the 10,000 or 20,000 volts, or whatever the line pressure may be, to transmit the power by their aid through the wires leading to the points of consumption at these pressures, and they are there transformed down to the pressures at which the currents are to be employed. The transformation is very often accomplished by two sets of transformers. Thus, if the currents are generated at, say, 500 volts, the first set of transformers may increase the pressure to 2000 volts, and the secondary currents from these transformers may be taken as the

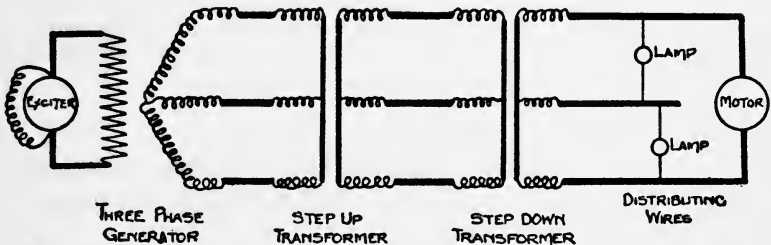

FIG. 104.—Diagram of Connections for Three-phase Extra High Tension Distribution with Step Up and Step Down Transformers.

primary currents of a second set of transformers, in which the pressure is increased to 10,000 or 20,000, or whatever the line pressure determined upon may be. And the same process may take place at the consumer's end. The line pressure may be reduced first to 2000 or 3000 volts, and any motors that are working at that pressure supplied from the secondary coils of this first set of transformers, and a portion of the current taken to a second batch of transformers where it is reduced to 500, or whatever the working-pressure of the other motors may be, and this may be carried farther by transforming a small portion of the current by separate transformers, specially to 100 or 110 volts for the lighting service. As explained also, the rotary convertor is a transformer as well as a convertor, and may be employed for the purpose, within the limits of its own capacity. Figs. 103 and 104 are diagrams of connections for high tension and extra high tension three-phase distribution.

The Main Switchboard

By the Home Office Regulations for the use of electricity in coal mines, it is necessary that a main switchboard shall be provided. It is also advisable in every case, whether required by law or not. The main switchboard is the clearing-house of the generating and distributing systems. The current from all the generators is brought to the main switchboard, the current for all the motors, lamps, etc., is taken from the main switchboard. The switchboard itself consists of slabs, either of marble or enamelled slate, the marble, if chosen, being free from metallic veins, the slabs being mounted on a steel framing, fixed vertically. The slabs are known as panels, and there should be a panel for each generator, a panel for each feeder or distributor set of cables, and panels for each auxiliary apparatus, such as boosters, accumulator switch gear, etc. On each generator panel there should be an ampère meter, showing at any instant the current the machine is delivering, a volt meter, showing the pressure at which it is being delivered at the switchboard, switches to disconnect the generator completely from the switchboard, one or more circuit breakers as they are called, to disconnect the generator automatically from the switchboard, fuses in each lead also, to disconnect it automatically from the switchboard, and there is usually a field current regulator, generally a wheel fixed in front of the board, which turns an arm over a succession of contacts arranged, the successive contacts cutting in or out successive lengths of a resistance employed to regulate the strength of the current passing in the field coils of the generator. On the generator panel also is often carried a meter, showing the number of units the generator has furnished during any period. It also sometimes carries recording ampère and volt meters, designed for the same purpose, these giving a record upon a chart, similar to that of a barograph, of the variations of pressure and current furnished by the generator during the twenty-four hours. Each feeder or distributor panel should carry an ampère meter, switches, circuit breakers, and fuses, for disconnecting it from the switchboard. It also sometimes carries meters showing the number of units delivered to each feeder during the twenty-four hours, and sometimes recording ampère meters. It is also sometimes arranged to have pilot volt-meter wires at certain distributing or feeding points, as, say, the pit bottom, the distributing point in-bye, etc., the pilot wires being small signal wires, and in this case being connected with a volt meter fixed on the feeder panel, showing the attendant the pressure at any instant at the distributing points. A recording volt meter is also sometimes fixed on the feeder panel of the switchboard, recording the variations of pressure at this point.

The accumulator booster panels will carry ampère and volt meters, switches, circuit breakers, fuses, rheostats, etc., enabling the attendant to completely control the working of this apparatus at the switchboard.

Where three-phase currents are employed, and the bus bar system, explained below, is also employed, synchronizing apparatus is necessary. This is carried on a panel by itself. By synchronizing is meant, arranging that the pressures and currents generated by the machine that is about to be connected to the service are exactly the same, at any instant, as those already in service, the currents and pressures rising and falling exactly in unison with those already passing in the system, and for this purpose it is necessary to have some apparatus which will show when the two are in unison. Synchronizing apparatus is described on p. 249.

There are also switches arranged for connecting the feeders to the "bus bars," and for connecting each generator to them. Plates 12A and 13A show main switchboards suitable for mining work, and Plate 12B shows the back of the board shown in Plate 12A, with the cables, etc.

The Parallel or Bus Bar System

There are two methods of arranging the connections between the generators and the feeders or distributing cables, known respectively as the "parallel" or "bus bar" system and the "independent" system. In generating stations for town supply, and for the distribution of power in the counties, the bus bar system is almost universally employed. It has also been adopted in many of the collieries where power stations have been laid down for groups of mines. In the bus bar system there are two or three substantial copper bars fixed on the main switchboard, usually behind the board, though some firms prefer to fix them above the board. The generators which are supplying the service must deliver current at the bus bars at exactly the same pressure. If the pressure delivered by any generator at the bus bars falls below that delivered by the other generators, it not only cannot deliver current, but its own coils become paths for the current supplied by the other generators, and this was the author's great objection to the use of the bus bar system in private works. Where, however, the generating station is of sufficient size to warrant keeping a sufficiently skilled attendant at the switchboard, the danger practically disappears; and, on the other hand, the bus bar system enables the engineer-in-charge to conveniently distribute the load between the machines in service as he pleases. Figs. 105 and 106 show the connections for shunt-wound and separately excited

machines, when connected to the bus bars. As explained in Chapter IV., the initial pressure created by the armature of any

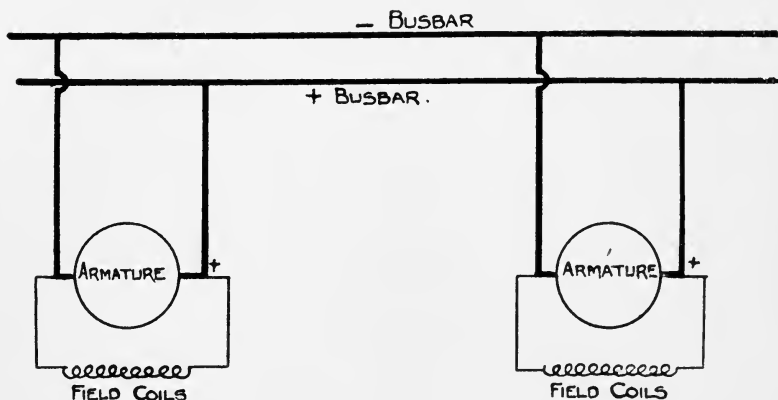

FIG. 105.—Diagram of Connections of two Shunt-wound Continuous Current Generators to a pair of Bus Bars.

generator is subject to a charge for the passage of the current through its coils to the brushes, and this lowers the actual pressure delivered by the machine, exactly in proportion to the product of the current

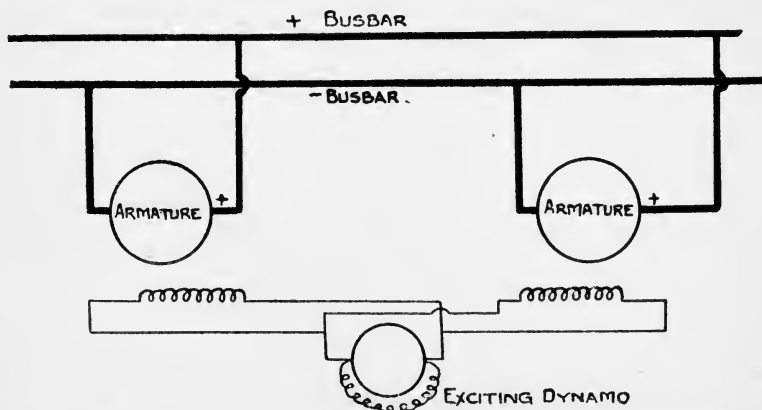

FIG. 106.—Diagram of Connections of two Separately Excited Machines to a pair of Bus Bars.

passing, and the resistance of the armature. When no current is passing, the pressure at the brushes is the initial pressure created by the armature, and it becomes steadily less as the current passing

through the armature increases. The engineer-in-charge has at his command two variable quantities, with both continuous and alternating current machines, by which he can alter the pressure at will, viz. the speed at which a machine is running, and the exciting current passing through the coils of its field magnets. In practice the speed is not much altered with continuous current machines, and not to a large extent with alternating current machines, the pressure being raised or lowered by switching out, or in, resistance in the field coils, by the rheostat on the switchboard. When the machine, whether continuous current or alternating, is brought into service, if the pressure it is delivering at its terminals, when no current is passing, is exactly the same as the pressure existing between the bus bars at the

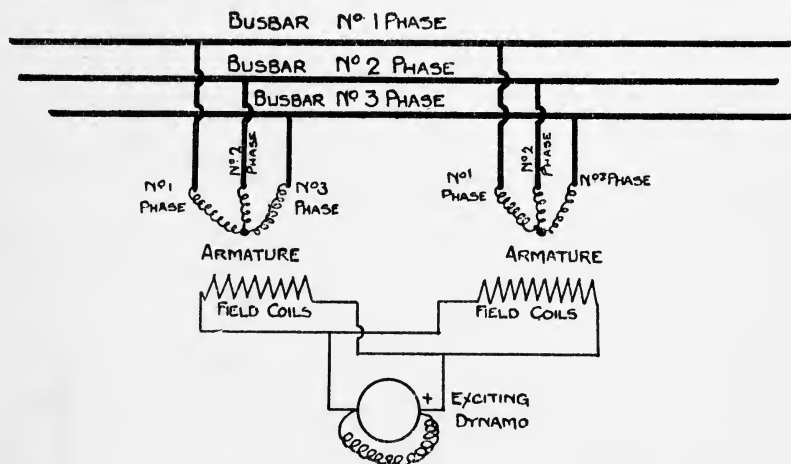

FIG. 107.—Diagram of Connections of two Three-phase Generators connected to three Bus Bars.

instant, it will furnish no current to the outer service, and, on the other hand, its coils will not provide a path for current from the other machines. If its pressure is above that of the bus bars, it will immediately furnish current to the system, until the charge made upon its initial pressure for the passage of the current brings its pressure at the bus bars down to the pressure of the other machines delivering. Hence, by increasing the excitation of any given generator, the proportion of the load it takes is increased, and by decreasing the excitation, the proportion is decreased, providing that the steam furnished to the engine driving the generator is proportioned to the work the machine is being called upon to perform. Hence it will be seen that, providing the engineer-in-charge and the switchboard attendant understand the matter, the distribution of the load between

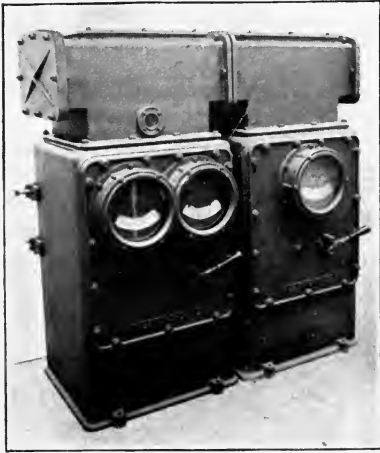

PLATE 16A.—Westinghouse Iron Distributing Boxes, for use in Mines.

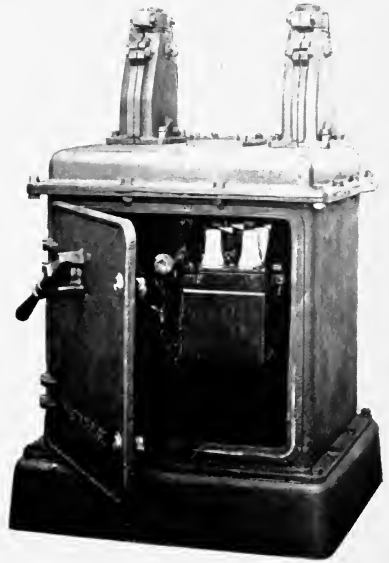

PLATE 16B. — Westinghouse High Tension, Gas Proof Switch for use in Mines. The Door cannot be opened if the Switch is closed.



PLATE 16C.—Ferranti Double Pole, no Voltage Circuit Breaker, with Cover removed. The Circuit is remade by the Handle shown below.

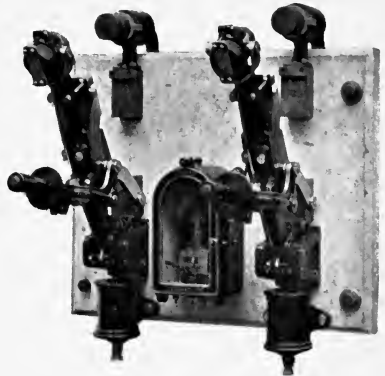

PLATE 16D.—Ferranti Double Pole Overload and Reverse Currents Carbon Circuit Breaker with Circuit Oven.

the generators in service is a very simple affair. For instance, suppose the station to have been running on light load, with one generator and its accessories furnishing the whole of the current required, and the heavier load to be gradually coming on. The engineer-in-charge will run up a second unit to its proper speed, arrange its exciting current so that it furnishes either the same or a slightly higher pressure than that of the bus bars, bring it to synchronism, if the service is alternating, switch it on to the bus bars, and then gradually increase the pressure it is generating, also increasing the supply of steam or gas to its engine, till it has taken the proportion of the load he intends it to. If the station is run with a small machine during light load, and this machine is allowed to rest and cool during the time of heavy load, he will gradually relieve the light load machine of the whole of its load, bring its pressure down to that of the bus bars, and then switch it off. With alternating currents, either single, two or three phase, as explained, it is also necessary to bring the incoming machine into synchronism, and this is done by the apparatus described below. Fig. 107 shows the connections for three-phase generators, when connected to bus bars.

Synchronizing Apparatus

The earliest arrangement of synchronizing apparatus consisted of two incandescent lamps receiving current from the secondary coils of two transformers, the primary coils of which were connected, one to the bus bars, and the other to the incoming machine, the two lamps with the two secondary coils being connected in series. When a machine was to be put into service it was run up to speed, its pressure regulated, and then the synchronizing apparatus was connected. When the currents from the machine coming in, and the bus bars, were in synchronism, both lamps would glow brightly, and the light would vary as the machines got in or out of synchronism, the changes being very visible in the lamps. In some cases one lamp was employed, connected to the two secondary coils. When the lamp was seen to be burning brightly the attendant would switch the machine in, and if he had judged rightly the incoming machine would then take a small portion of the load, which could be increased by increasing the excitation of the field magnets and the steam supplied. If he made a mistake when synchronizing, either the incoming machine, or those in service would receive current through their coils, and the synchronizing current, as it is called, would tend to pull the machines into synchronism. The synchronizing current sometimes strains a machine, especially if it is a heavy current. Apparently the machines themselves dislike a synchronizing current, as in some cases they give a loud screech. The later forms of

apparatus consist of dial instruments fixed on the synchronizing panel, carrying needles in front which move to the right or to the left, according as the periodicity of the incoming machine is greater or less than that of the bus bars. The synchronizers or synchroscopes, as they are called, consist of coils of wires carrying currents taken from the bus bars and from the incoming machine, and the arrangement is very similar to that of the induction motor. When the machines are out of synchronism one of the coils tends to turn upon its axis, it being movable and carrying a needle, and the extent to which it moves shows how much the incoming machine is out of synchronism. It is evident that the lamp system and the dial synchronizer can be used together, but the dial synchronizer is gradually displacing the lamp system, as being better, simpler, and more accurate. In America the lamp system was worked on opposite lines to those which rule in this country. Synchronism was shown when the lamps were dark. In the author's opinion this is hardly a satisfactory arrangement, as there is a large portion of the pressure of any lamp service during which the lamp is perfectly dark.

Paralleling Compound Continuous Current Machines

The paralleling of shunt-wound continuous current machines is carried out as shown on p. 247, but it is sometimes an advantage,

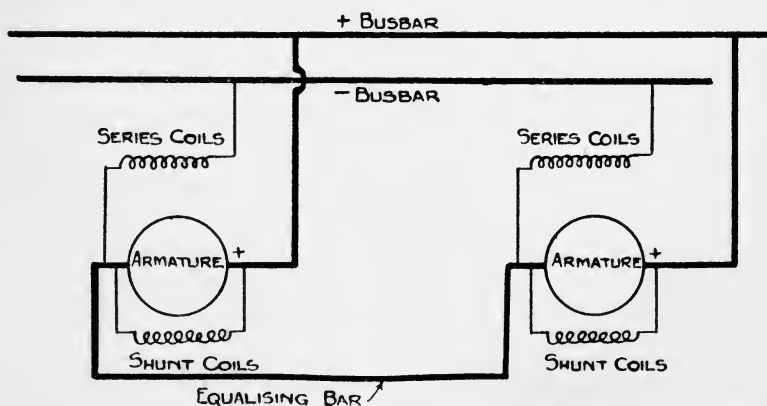

FIG. 108.—Diagram of Connections of two Compound Machines connected to two Bus Bars.

as explained, to employ compound machines, as where it is convenient to raise the pressure at a given distributing point, as the current

delivered from that point increases, and it then becomes not quite such a simple problem to connect the machines in parallel, to ensure that each shall take its share of the load it was intended to, and that the current in the series coils shall not vary the pressure delivered by its own machine in a manner it was not intended to. The connections to the bus bars are arranged thus: the positive brush is connected to the positive bus bar, and the end of the series coil forming the other terminal of the machine is connected to the negative bus bar, and what is called an "equalizing" bar is fixed on the switchboard, and connections are made to the equalizing bar from the negative brushes of all the machines in service. The object of the "equalizing" bar is the same as that of the equalizing connections mentioned in describing the construction of multipolar continuous current generators, viz. to maintain the pressures between the positive and negative terminals of the different machines at the same figure. The arrangement does not interfere with the distribution of the load, it merely ensures that the pressures of each individual machine shall be the same. The connections are shown in Fig. 108.

The Independent System

In the independent system, which the author strongly advocated for private works, and which he still advocates in those cases where the plant is small, and is left in charge of an unskilled man, each generator is connected directly to one or more sets of feeder cables, there being no connection between the generators themselves nor between the sets of feeder cables, except when two or more are connected to the same generator. The working arrangement is as follows. During light load the one generator running will be connected to all the feeder cables, and will supply all the current. When the load commences to increase, and the additional units are to be brought into service, one or more sets of cables are switched over from the light load generator to one or other of the new generators, as they come into service. When the load decreases again, and the full load generators are to be taken out of service, the feeder cables are gradually switched from each of the units on to the light load machine. The switch arrangement is more complicated than with the bus bar system. It will be seen that in the case of the bus bar system the whole arrangement is simplicity itself. Any machine can be withdrawn from service by throwing its switch open, and any feeder can be disconnected from the system by throwing its switch open, though this should only be done when no current is passing. Further, except in case of accident, the whole of the feeders remain continuously connected to the bus bars, the only changes that are

made being in connecting or disconnecting successive generators. With the independent system, however, two distinct operations have to be performed, the feeder cables have to be disconnected from the machine from which they are receiving current at the moment, and connected to the machine from which they are now to receive current, this involving a distinct break in the service and a wink in the lights, though this may not be serious. The arrangement also involves, sometimes, some complication where there are several machines, and a great deal of care at the switchboard to avoid arcing.

When there are only two machines, as in the case of a small mine, the arrangement on the independent system is very simple. Each feeder has a "two-throw" switch, as it is called, arranged with its contact bar permanently connected to one feeder cable, with continuous currents, and with the three contact bars or the four contact bars connected to the three or four cables, with three or two phase alternating currents. The contact bars are faced by two sets of contacts, fixed widely apart, connected to one terminal of each of the machines, the other terminals of all the machines being connected to a common return, to which also the return cables of the feeders are also connected. When it is desired to switch over a given feeder from one machine to the other, the contact bar is very quickly disconnected from the contacts with which it is in connection, and rapidly pushed into contact with the other set of contacts, the operation only occupying a few seconds. For more than two machines, almost the only arrangement possible is a similar one to that which was explained in connection with telephone exchange service. One set of terminals of all the machines and one set of the distributors are connected together with continuous current machines, and the other terminals of the machines are connected to their own bars, which are fixed either horizontally or vertically, the two sets of bars having holes in them where they cross, and connection being made by plugs passing through the two. The connection has to be made from one to the other with this system very quickly, and the author does not see how it is possible to arrange a system in a mine, with two or three phase currents, since all switching must be absolutely instantaneous. The independent system, however, with switching on these lines was carried out for some time at a few of the town electricity generating stations, but is now practically displaced everywhere by the bus bar system. The author's advice would be to employ the independent system where the plant is small, and a skilled attendant cannot be afforded, but to employ the bus bar system where more than two machines are employed, and to also employ an attendant of sufficient skill to deal with it, whatever the cost may be.

The arrangement of bars crossing each other at right angles, for

connecting machines and feeders, is used with the bus bar system, but switching there only takes place when the current is off, other switches having been opened previously, to break the connection.

Switchboard Gear for High Tensions and Extra High Tensions

For high tension, and more particularly for extra high tensions, where employed, special arrangements are necessary, both to protect the switchboard attendants, to prevent the formation of arcs between the different portions of the switch gear, and to prevent the breaking down of the insulation between different portions of the switching apparatus, by the leakage current which is always passing. The usual arrangement employed is, the switch gear for each generator, and for each feeder is enclosed in a separate cell, built up of brickwork, or some similar arrangement, and with a substantial thickness between adjacent cells. The same system is adopted in connection with the cell arrangement as on the switchboard. There will be the switch, the circuit breakers, fuses, transformers where required, in one set of cells which will be divided, as explained, from the next set of cells, and each of the cells belonging to each set will also be divided from each other by brickwork, or similar arrangements. The switches are worked electro-magnetically from what is called an operating board, fixed usually in front of, but a little distance from, the switch cells. On the operating board are smaller switches, which enable the switchboard attendant to operate the large switches in their cells. The main switches are usually arranged so that the working contacts are enclosed in a tank of oil, similar to that employed for the immersion of transformers, and a common arrangement is, two vertical rods, representing the two fixed contacts of the ordinary switch, project from two insulators above, down into the oil in the tank, where they are faced by a contact piece, which is moved by a third vertical rod controlled from above. The contact rod is sometimes moved by an electric motor, and sometimes by a solenoid. The B. T. H. Co. employ a motor, the Westinghouse Co. a solenoid. In either case the motor or the solenoid are supplied with current from a low-tension service, controlled by a switch on the operating switchboard, and when the switchboard attendant closes the switch on the operating switchboard, a current passes round the motor, or the solenoid coils, causing them to move the contact bar into connection with the vertical contact pieces. When the switch is to be opened, the controlling switch on the operating board is opened, and springs, weights, or other equivalent mechanism come into operation, pushing the contact bar away from the fixed contact rods, and opening the circuit, the arc

which is formed being in the oil in the tank, and being quickly extinguished by it. This arrangement may be employed for any pressures from 650 upwards, but it is usual in mining work, after 650 volts have been passed, to go direct to 2000 or 3000, preferably the latter, as it is the limit of high tension working. It is of more importance to enclose the contact arrangement within separate cells, as described, as the pressure increases. Plates 14A and 14B show a Ferranti three-phase 10,000 volt switch, electrically operated; and Plates 14c and 14D, and 17C, Ferranti's mining and high-tension switches operated by hand; and Plate 17D, Messrs. Reyrolle's high tension three-phase hand switch.

Sub-station Switchboards

Switchboards are necessary at all sub-stations, that is to say, wherever the current is received for distribution from the main switchboard. Where the mine receives current from a power station supplying a number of mines, some form of switchboard is necessary to deal with it on its arrival. Figs. 109 and 110 show the connections of a sub-station switchboard for colliery work, taking current at 6000 volts, and transforming to 2000, as arranged by Messrs. Reyrolle. Also, at places such as pit bottoms, distributing points in-by, etc., which may be termed sub-stations, switchboards are necessary. The switchboards for dealing with current received at any individual mine, from the main generating station will be a small replica of the main switchboard, there being one panel corresponding to the generator panels of the main switchboard, for the current received from the main generating station, which will have an ampère meter, a volt meter, main switch, circuit breakers and fuses, with sometimes meters and recording volt and ampère meters. The distributor or feeder panels will be counterparts of the distributor and feeder panels of the main switchboard, but they may be smaller. Also, unless motor generators are fixed in the sub-station, there will be no resistances or rheostats, but where they are employed, as suggested in previous chapters, they will have panels of their own, arranged very similarly to the panels of the main switchboard designed for the same purpose.

The switchboards for such sub-stations as the pit bottom and distributing points in-by will depend for their size, etc., upon what they have to deal with. Where a high pressure service is delivered at the pit bottom, such as 3000 volts, the sub-station switchboard at the pit bottom, should be of something the same character as the cell arrangements described in connection with the main switchboards. It is of great importance that attendants at the pit bottom should have very little chance of receiving shocks. One arrangement employed

switch gear, circuit breakers, fuses, etc., are contained in these cells, each cell being separated from its neighbour by a substantial brick wall. Each cell is closed by an iron door, formed by a single casting planed to fit the doorway, and it is arranged that the door cannot be opened

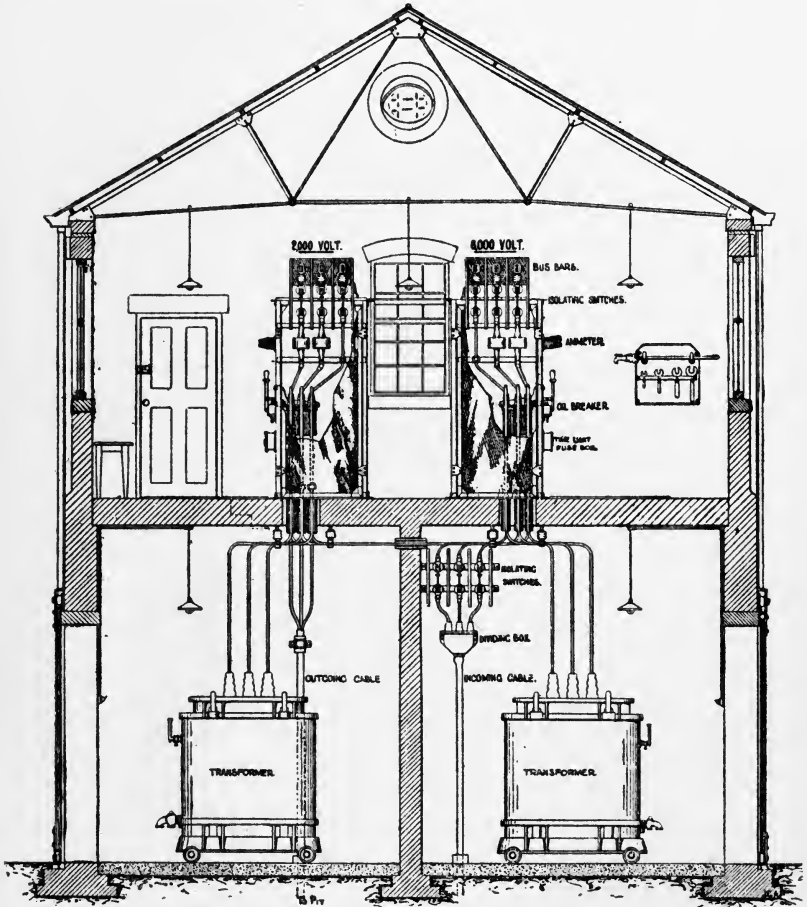

FIG. 110.—Back of Sub-station Switchboard, whose Diagram is given in Fig. 109, showing the Transformers and Switch Gear.

until the connection between the supply cables and the switch gear is broken, this being accomplished by a wheel in front of the door, similar to that used for rheostats on a switchboard. The measuring instruments for each of the cells are fixed on the brickwork above the cells, so that all that is going on in each of the circuits can be seen.

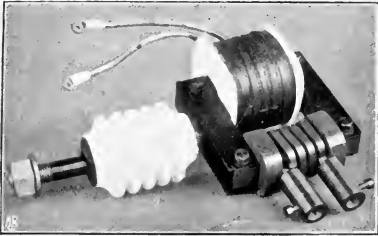

PLATE 17A.—Current Transformer for use with High Tension Switchboards, as made by Messrs. Elliott Bros.

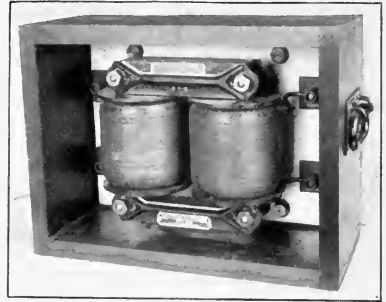

PLATE 17B.—Potential Transformer for Switchboards, shown in Fig. 38.



PLATE 17C.—Ferranti Mining Type, Oil Immersed, Gas-tight Triple Switch with Fuses.

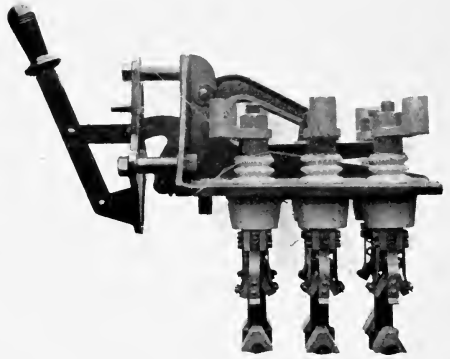

PLATE 17D.—Messrs. Reyrolle's High Tension, Three Phase, Oil Enclosed Switch, with Oil Tank removed, showing Contacts.

[To face p. 256.

As explained, in every sub-station the incoming cable from the generating station takes the place of the cable from the generator itself, and this rules in the present instance, the cables, which are three phase at the Powell Duffryn Co.'s works, being connected to three bus bars behind the cells, the connections between the bus bars and the switch gear in the cells being broken when the door is open. One of the cells answers to the generator panel, and the others to the feeder panels. For continuous current two wire service at pit

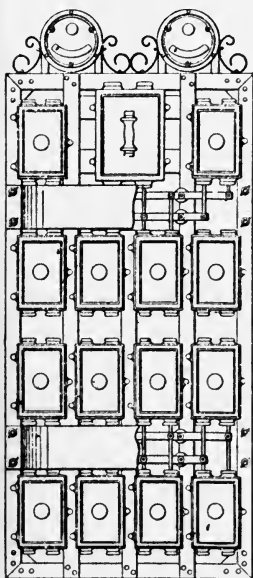

FIG. 111.—Diagram of Double-pole Distributing Board made by Messrs. Berry, Skinner & Co.

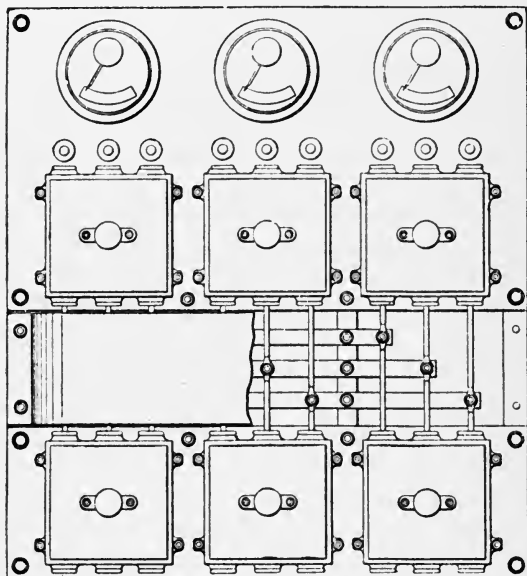
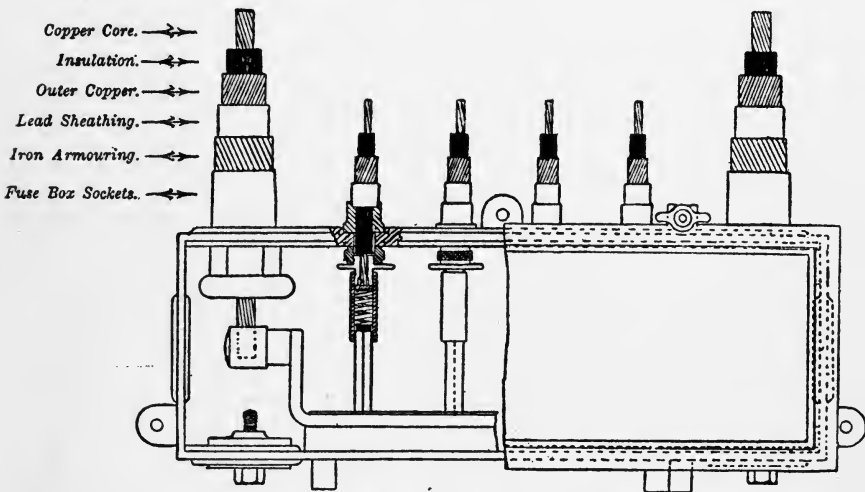

FIG. 112.—Diagram of Three-phase Triple-pole Distributing Board made by Messrs. Berry, Skinner & Co.

bottoms, etc., all that are necessary are, switches and fuses and preferably circuit breakers as well, to disconnect the supply cables entirely from the seam, just as the generator is disconnected from the switch-board, and switches, fuses, and circuit breakers for each set of cables leading from the switchboard to any given district, or to supply any given group of motors. It is wise also to have ampère meters on both supply cables from the service, and on the branch feeder cables, and there should be a volt meter connected to the supply cables from the service. The whole should be mounted in the usual way upon slabs of marble or enamelled slate fixed to steel framing, and should

either be placed in an inaccessible position, as in the deputy's cabin, or should be placed in a locked cupboard. A form of switchboard for use in underground engine houses that is finding favour, and that is employed even with high tensions, consists of the usual panels fixed to iron or steel framing, with the switch gear instruments, etc., mounted upon it, the whole being enclosed within a substantial cupboard of wire gauze or wire netting. The arrangement has the advantage that the apparatus is protected from accidental contact, the wire cage being locked, while the apparatus itself can be seen from outside, and any trouble that is visible, noted.

For distributing points in-by-e, where the space is often very



4-Way Distributing Fuse Box
(Cover partly removed, showing Section of Socket and Fuse.)

FIG. 113.—Diagram showing Messrs. Mavor & Coulson's Fuse Distributing Box, used with their Concentric Cables.

limited, and where both the ground and any supports that are available may be moved frequently, enclosed iron boxes, made sufficiently strong to withstand the rough wear and tear of the mine, but sufficiently portable to be moved fairly easily from place to place, are to be preferred. The iron boxes should be made gastight, and the cables entering them should pass through gastight glands. There should also be careful provision against accidental connection between the conductors of the cables, and the iron of the boxes. The boxes should always contain a switch, double, triple or quadruple pole, for completely disconnecting the supply service from the box, and from

the cables supplied from the box, and it should be arranged that it is not possible to open the box if the supply switch is closed. There are several arrangements on the market ensuring this, the principle of the whole of them being the same, viz. the door as it closes either pushes in a plunger which unlocks the switch gear, or turns a lever which, when the door is open, prevents the switch contact arm from moving into contact. Plates 15C, 16A and 16B, show forms of these, also Figs. 111 and 112. Arrangements may be made for connecting the branch cables through what are known as switch fuses, which perform the double office of a switch and a fuse, as their name implies. They consist of fuses of various forms, carried sometimes between a pair of clips, sometimes in other ways, but there is always a handle of insulating material, arranged so that the hand of the operator is protected from any arc or spluttering of metal that may take place, when either the fuse "blows" or the switch is opened. If any excess current passes through the circuit the fuse is protecting, the fuse "blows," and if it is desired to open the circuit, it may be done by pulling the fuse out by the insulated handle provided for it. It should be noted that it should be part of the arrangement that fuses can only be changed, and the fuse switches only opened, when the supply switch is also open, this following naturally where the boxes cannot be opened without first opening the supply switch. Fig. 113 shows one of Messrs. Mavor & Coulson's fuse distributing boxes, used with their concentric cables.

For gate road connecting boxes, such as must be employed for coal-cutting machines, and that may be employed in certain cases for pumps, and other apparatus that are moving forward, all that is necessary is, provision for connecting and disconnecting the two, three, or four cables, and for their being automatically broken by fuses blowing in case of short circuits, the whole being enclosed in a portable iron box, that cannot be opened when the circuit is closed. The arrangement of the connections of flexible cables for coal-cutting machines to gate end boxes will be discussed in connection with the machines themselves.

Measuring Instruments for use on Main and Sub-station Switchboards

Instruments used on the switchboards are of the moving coil, moving iron, gravity, and hot wire types, described below. Electrostatic voltmeters are also employed. They are made in the circular form, with dials occupying approximately half the circumference, in the sector form, giving a large dial with comparatively small movement, and on what is known as the edgewise pattern. The edgewise

pattern is really the sector form with the circumference of the sector arranged for the scale, and turned towards the attendant. The circular instruments are made with from 8-inch dials up to 11 inches, the sector instruments having scales rather larger. For the measurement of continuous current strengths above a certain figure, the current is shunted, only a fraction of the actual current measured passing through the ampère meters. With alternating currents transformers are used, where the currents are above a certain strength, the current to be measured passing through the primary coil, the secondary coil of the transformer being connected only to the coil of the instrument. Forms of transformers are shown in Plates 17A and 17B, for use with switchboard instruments. For pressure measurements, resistances are employed with continuous currents, and transformers with alternating currents, the pressure at the terminals of the instrument being a small fraction of that of the actual line or generator. The sector type and the edgewise type are frequently arranged with their dials illuminated by incandescent lamps fixed above the switchboard, the connections being brought up to them from behind.

Moving Coil Instruments

In the moving coil instruments there is a permanent magnet with steel pole pieces, enclosing a cylindrical space, in which a wire coil, carrying a pointer at its centre, is pivoted. It is all important that the permanent magnet should be of constant coercive force, and for this purpose a special alloy of steel, in which tungsten is one of the components, is employed. The permanent magnet is intended to create a constant magnetic field within the cylindrical space in which the coil moves, and the measure of the strength of the current passing through the coil is the angular distance through which it is moved away from the zero point. The angular movement of the pointer is uniform throughout the scale, and the zero point may be either on the left or in the centre. The construction of the instruments of the moving coil type for measuring voltage, and for measuring current, is exactly the same, except that the ampère meters are provided with shunts consisting of a number of strips of metal whose coefficient of resistance is very low. They are virtually millivolt meters. For instruments required to measure currents up to 100 ampères, the shunt is usually contained within the instrument itself, but for currents above that figure it is carried in a separate case.

Gravity Instruments

In these instruments there is a circular coil of wire, and inside the coil a crescent-shaped piece of iron attached, by means of a radial member, to a pivot upon which the pointer works. The instrument is fixed vertically, and in that position the crescent of iron falls to its lowest point when no current is passing. When a current passes through the coils of the instrument, the crescent is moved out of its position by the magnetic field created within the cylindrical space inside the coil, the needle pointer moving over the dial in unison with it. The indications of this instrument are not uniform. The instrument is made to measure currents up to certain figures, as from 0 to 120 volts, from 0 to 100 ampères, and so on. In these cases the indications up to 70 in voltmeters are very small, the scale then gradually spreading out so that when the instrument is reading what is usually the normal pressure, 100 or 110, differences of even 1 volt are easily distinguished. On the ampère meters the readings commence for 100 volt ampère meter at from 10 to 13 ampères, but the spaces of the scale are very small, until the neighbourhood of the figures the instrument is intended to read normally are reached, after which the spaces become smaller again for high tension.

Hot Wire Instruments

These instruments depend upon the fact that when a current passes through a wire and heat is liberated, the heat causes expansion of the wire, the expansion being measured by the motion of a pointer over a scale.

There are two forms of the instrument. In one the wire which is to be heated is enclosed in a long tube, with a cylindrical box at its end, carrying the pointer and dial on its face. The tube may be fixed either in a vertical or in a horizontal position, the dial being arranged accordingly. In the other form of apparatus the wire is enclosed within a cylindrical case, fixed vertically, with the dial occupying the upper portion. In both forms of instrument very thin platinum silver wire of high resistance is employed, the wire used in the tube form being very long, while in the dial form is short. In both cases the wire is stretched tight, it being carried over pulleys at the top and bottom of the tube in the long form, and is kept in tension by means of a spiral spring. In the tube form, the tube itself is made in two halves of two different metals, arranged so that the expansion of the two from the heat generated in the wire shall neutralize each other, and the indications on the dial be entirely confined to the elongation of the wire from the heat of the current.

In the hot wire ampère meters, the shunt principle is also applied in a similar manner to that of the moving coil apparatus. The motion of the needle of the circular and edgewise form of the instrument is damped by means of a permanent magnet, between the poles of which a thin aluminium disc works, so that the needle comes quickly to rest.

The Electrostatic Voltmeter.

The electrostatic voltmeter is employed for measuring high pressures. The apparatus works by reason of the attraction between oppositely charged conductors at different electrical pressures, and the repulsion of similarly charged bodies, the attraction and repulsion being in proportion to the square of the difference of the pressure. There are two principal forms made, known respectively as the multicellular and the vane instruments. In the multicellular instrument, which is intended for measuring comparatively low voltages, there are a number of small insulated cells, formed of triangular brass plates, fixed into slots cut in a vertical back piece, the spaces between the plates forming the cells. Two sets of cells are fixed with their plates horizontal, and opposite each other, on a vulcanite support. The moving member of the system consists of a number of vanes fixed horizontally upon a light vertical spindle, in such a position that one side of each vane lies in each of two cells opposite each other. The vanes, with their spindle, are suspended by a fine, iridio-platinum wire from a torsion head at the top of a vertical brass tube surmounting the instrument. The pressure is communicated to the vanes through the wire suspension. When a pressure is delivered to the cells on the one hand, and to the vanes on the other, the vanes turn in a horizontal plane, the suspending wire carrying a light aluminium pointer over a horizontal circular scale fixed at the top of the instrument.

Switches, Fuses, and Circuit Breakers

It was explained in describing switchboards, that switches were provided for connecting and disconnecting generators, feeders, etc. Modern switches are all constructed on certain main lines. They must all conform to certain conditions. In every switch there is a moving contact bar, which makes connection between two fixed contact blocks, or springs, to which the ends of the cable connected to the circuit to be controlled by the switch are brought, and the contact bar must in all cases be of sufficient size to allow the passage of the largest current the switch will have to control, without an appreciable rise of temperature. The surfaces of contact between

the contact bar and the fixed contacts must also be of sufficient cross-section to allow the passage of the current from one contact to the contact bar, and from the contact bar to the other contact, again without appreciable rise of temperature. The rule adopted by the principal makers of switches is 1000 ampères per square inch for the contact bar, and 75 ampères per square inch for the contact services, with the maximum currents the switches are designed for. Switches must also be so arranged that on opening a circuit no arc can form between either the fixed contact pieces, or between them and the moving contact bar. As explained before, when a circuit is opened, especially circuits in which there are a number of coils of wire in which a current is passing, the return to the circuit of the energy delivered to the magnetic field when the circuit was closed, and that delivered to the electrostatic condenser, create a very large increase of pressure, which causes a spark to pass across the break at the moment the circuit is opened; and if the break is not made of such a size that the spark cannot persist, in a very short interval of time an arc will be formed, just as in the arc lamp, and the working portions of the switch, the stationary contacts, and sometimes the moving contact bar, will be seriously damaged, the arc producing temperatures that quickly melt brass, copper, etc., and that destroy the insulating material upon which the switch is fixed.

There are two principal lines upon which switches are constructed, which are really variations of one type. A favourite form is the knife switch, in which a knife blade, constructed of copper, or, in the case of small switches, of brass, is the moving contact bar, and is forced between two spring stationary contact pieces, when the circuit is closed. This form of switch is made either "slow break" or "quick break." Slow break knife switches are made for currents with pressures below 300 volts, and in them the quickness of the hand is depended upon to break the arc. In quick break knife switches a spring comes into operation at the instant the moving contact bar is leaving the fixed contacts, takes charge of the moving contact bar, and throws it quickly back out of sparking distance, the moving contact bar being constructed so as to move freely, apart from the insulated handle, or, as it is termed, with a loose handle. The Westinghouse Co., the Ferranti Co., and others have developed standard knife switches, in which the knife blade is always of one size and one thickness, and a number of knife blades are put together in one switch for different strengths of current. Thus a single knife blade will carry currents up to a certain number of ampères, two knife blades up to double the number of ampères, and so on.

Switches are made to open the circuit of one cable, of two, three, or four cables, as required, and are termed single pole when they break only one cable, double pole for two, triple pole for three, and

so on. Single-pole switches are employed for opening the circuit of one cable of a continuous current system, double-pole switches for opening both cables of a continuous current system, triple-pole for opening the three cables of either a three-wire or three-phase system, and quadruple-pole for the four wires of a two-phase system. It should, perhaps, be mentioned that it is necessary to open all three cables of a three-phase, and all four cables of a two-phase system simultaneously, except in those cases where lamps or other apparatus are connected between the different phases. Fig. 114 shows a form of double-pole switch, enclosed in an iron case, intended for mining work.

Switches are also distinguished as single and double break, according to whether the contact bar makes two breaks between itself

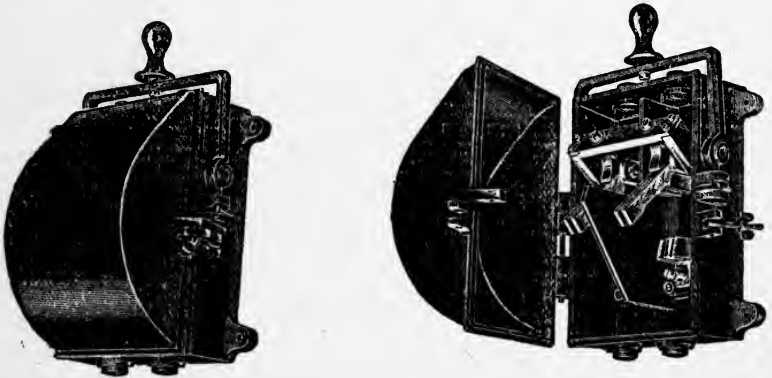

FIG. 114.—Double-pole Switch enclosed in an Iron Case made by the Electric & Ordnance Co.

and the stationary contact points, or whether there is only one break between the contact bar and the stationary contact itself. Switches are very rarely made, and should not be used where it can be avoided, in which the break is between the contact bar and the stationary contacts, because in that case the current has to pass through a hinge or some similar arrangement to reach the contact bar, and this is often a source of trouble.

The knife switch has been developed for single, double, triple, and quadruple switches, as it lends itself very readily to construction such that two, three, or four knife blades can be forced between their respective contacts by a single insulated handle, and can be withdrawn simultaneously by the same means. They have also been developed for single and double throw switches. The single-throw switch is the one that has been described, by which a circuit is

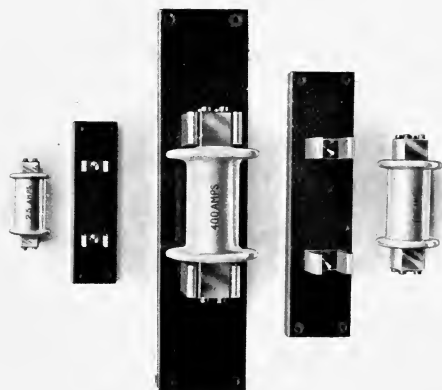

PLATE 18A.—Porcelain Handle Fuses, made by Messrs. Reyrolle.

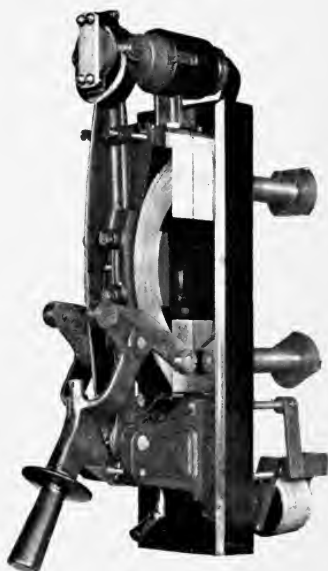

PLATE 18B.—Ferranti Carbon Break Circuit Breaker, closed.

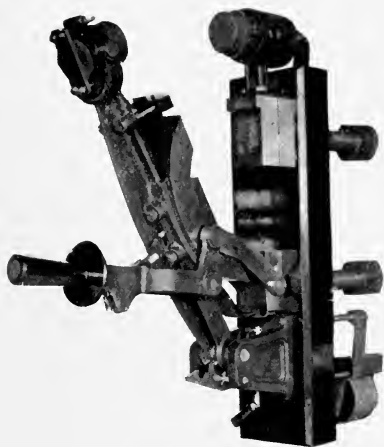

PLATE 18C.—Ferranti Carbon Break Circuit Breaker, open.

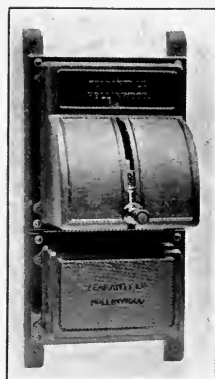

PLATE 18D.—Ferranti Triple Hole Overload, and no Voltage Circuit Breaker, with Cover, not Gas-tight.

[To face p. 264.

closed or opened. The double-throw switch is the one described in connection with the "independent" distribution system, by which a current is thrown over from one circuit to another. In America they are called throw-over switches, because the current is thrown over from one generator to another, or from one feeder to another. In the double-throw knife switch, which again is made for single, double, triple, and quadruple pole, there are one, two, three, or four pairs of knife blades fixed to one handle, each pair being at such an angle with each other that when one set of knives is in connection with its contacts, the other set is well clear of the other contacts. There are one, two, three, or four sets of contacts facing each set of knife blades, and the operation of throwing over consists in quickly forcing one set of blades between its contacts, at the same instant the other set of blades leaving its contacts. In another form of double-throw knife switch, there is only one set of blades which stand vertical between two sets of contacts fixed on a horizontal base, and the one set of blades is thrown quickly from one set of contacts across through an arc of 180° to the other set. Contact is made with one set of contacts by one edge of the blades, and with the other set of contacts by the other edge of the blades.

In the other principal form of switch, which is sometimes known as the chopper switch, and sometimes by other names, the fixed contacts are farther apart, and the contact bar is made with a straight piece ending in a bridge of some form, arranged to fill up the space between the two fixed contact pieces. In the form that was a favourite some years ago, the moving contact bar was built up of a number of thin sheets of copper, bent round a bar at the centre, to which the handle or moving mechanism was connected, and the ends being spread out in the form of a brush, the brush sweeping down between the fixed contact pieces. The chopper switch and the brush switch do not lend themselves so readily to double-pole, triple- and quadruple-pole construction as the knife-switch construction does. The action of the hand in closing or opening the switch has to be transmitted to the moving contact bars, through bars of insulating material, and it is sometimes difficult to fit these so that the whole of the contacts go in and out of contact simultaneously, and as it is necessary to provide pins working in holes, or something similar, in the bars of insulating material, these also wear with time, and tend to throw the switch out of gear.

For large currents a form of switch has been developed in which the contact is made between substantial copper surfaces, while the circuit is closed, but in which the final break is made between carbon contacts fixed for the purpose, and arranged to be renewed when burned out. The masses of copper may be in the knife form, or may consist of laminated copper bearing against or between stationary

contact pieces; but in all cases there is an auxiliary lever carrying the auxiliary carbon contact attached to the contact bar, and there is an auxiliary fitting on the switch base, carrying the auxiliary fixed carbon contact piece, which is arranged to engage with the carbon contact piece on the moving contact bar. When the switch is closed, the carbon contacts come into connection first, the handle operating the switch being arranged in this manner, the copper contact pieces then coming up as the switch is forced home, and being driven into their places. When the switch is opened, the handle first looses and releases the copper moving contact piece, throws it clear of the stationary contact piece, and then, as the handle moves on, it throws back the moving carbon contact piece, any spark that passes or arc that is formed being between the carbon contacts. This form of switch is arranged for double and triple pole, the different switches for the different poles being fixed one under the other, a vertical rod operating the three, the rod being actuated by a single handle.

Fuses

Fuses are intended to protect both the coils of generators, motors, and cables from the passage of currents that will heat them to a dangerous extent, and will damage the insulation. They are all constructed on the principle that certain metals have a lower melting point than copper, and that all metals in a very small section will be melted or disintegrated when a current passes through them of a certain strength. The principal metals employed for fuses are lead, tin, and copper. Alloys of tin and lead and other metals are also employed. Aluminium is utterly unsuitable for fuses, because when it is heated by the passage of a current through it, an oxide is formed on the outside of the wire, which has a considerable factor of cohesion, and holds the wire itself together for some time after the substance has really been melted, and therefore does not open the circuit. Lead and tin, and the alloys of lead, with tin and other metals, have two distinct disadvantages, they oxidize very freely when the current is passing, and from the moment they are put into service the current they will stand without fusing decreases, so that unless they are renewed somewhat frequently they are apt to break circuit at very awkward times, such as when an additional load is thrown on a distributing cable, a load that carries no dangerous heating properties, and that the cable should carry very conveniently. The other objection to lead, tin, and their alloys is when the fuse "blows," the molten metal is scattered all round the place where the fuse is, and there is usually a good deal of damage done to the enamelled slate, or whatever the fuse may be mounted on. For these reasons copper has

been employed a good deal, and a thin copper wire properly proportioned makes a very good fuse indeed. It does not oxidize as freely as the tin and lead fuses do. It does not splutter so much as they do, and it is generally more reliable. The fuse, whatever its form, consists of a short length of wire that will carry the current the cable or generator is to deal with normally, but that will melt, owing to the heat generated in it, if a current of 50 per cent., or 100 per cent., or whatever the fuse may be set to "blow" at, arrives. There are, however, some difficulties in connection with fuses. It is necessary in order that the fuse wire may be included in the circuit, that it shall be connected to metal blocks, to which the ends of the wires of the circuit shall also be connected, and these blocks absorb a certain portion of the heat liberated in the fuse wire, and they also dissipate a portion of the heat. This results in fuses varying in their action with the temperature of the surrounding atmosphere. In a cold, draughty passage a fuse will often allow a very dangerous current to pass where it would "blow" in a warmer atmosphere, such as an engine-room, with a very much smaller and sometimes less than the normal current. This has led to the development of what are termed "enclosed" fuses, consisting of wires of various metals enclosed inside of glass or metal tubes, the tubes being filled with various substances, such as oil with a high flash point, sand, asbestos, and chemicals which are designed to extinguish the arc which is formed when the fuse blows. It will be understood that one of the troubles in connection with fuses is the possibility of an arc being formed between the severed ends of the fuse wire. Enclosed fuses are gradually coming into service, though there have been some complaints, in the case of fuse wires enclosed in oil, that the oil has been fired by the arc formed, and the enclosing vessel has exploded. A variation of the enclosed fuse which is made by Messrs. John Fowler & Co., of Leeds, is the asbestos-covered fuse. In this fuse, wire of a certain section is covered with asbestos to a standard thickness, that it has been calculated will prevent the formation of any arc, and that will prevent the escape of heat from the fuse. The standard fuse is made for currents of 20 ampères, and a circuit is fused for any current by simply multiplying the number of single fuse wires fixed between fuse blocks. Another point in connection with fuses is the matter of the replacement of the fuse wires after a fuse has "blown." Time is often of considerable importance, and the fuse blocks are also nearly always in such positions that a man will receive a shock if the circuit to which the fuse is to be connected is alive, in the process of replacing the fuse wire. Hence a line of fuses has been worked out, in which the fuse wire is stretched between pieces of metal, held sometimes by bridges of vulcanized fibre, sometimes by bridges of porcelain; and again the bridge may

be a glass or porcelain tube, the porcelain tube, as explained above, in some cases forming the handle by which the fuse is replaced. In any case, the bridge is employed to handle the fuse by, and the

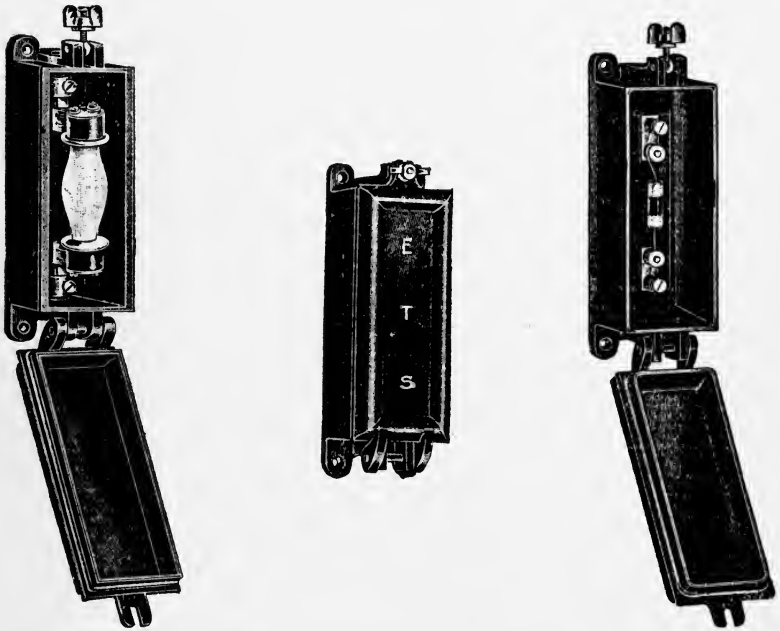

FIG. 115.—Fuses for Mining Work enclosed in Iron Case. The Fuse on the Left has a Porcelain Handle for removing it and for using it as a Switch.

metal terminals to which the fuse wire is attached are arranged to be pushed between metal springs, connected to metal blocks forming part of the circuit to be protected. Examples of these are shown in Plate 18A and Fig. 115.

Circuit Breakers

The circuit breaker is intended to perform the same office as the fusible cut-out, but to be more certain. In all forms of circuit breaker an electro-magnet is employed to open the circuit, and it does so by either releasing a trip action, or by moving a lever bodily. In all forms there is a provision for tripping by hand without danger to the attendant. Circuit breakers are made for breaking the circuit of a single cable with continuous current, when an overload arrives,

or when the pressure of the service falls below a certain figure, and also to open the circuit if a reverse current arrives, as when machines are connected in parallel and one of them is motoring. They are constructed to break the circuit of both cables of a two-wire service, of the three cables of a three-wire service, and the two, three, or four cables of an alternating current service. Plates 13C, 16C and 16D, and 18B, 18C, and 18D, show forms of Ferranti circuit breakers. There are also special arrangements described below, for delaying the operation of the circuit breaker.

Time Limit Circuit Breakers

For a power service the fuse has one advantage over the circuit breaker, it is not usually so quick in action, and the quickness of action of the circuit breaker in some cases leads to inconvenience. In the time limit circuit breaker a certain time must elapse, after the current arrives at the circuit breaker, before it operates. Time limit circuit breakers are principally of two forms, those in which clockwork is employed, and those in which electro-magnetic induction is made use of to interpose a lagging action upon the apparatus. In the apparatus in which clockwork is employed, a clock movement is held from running down by a pawl, which falls into a recess in a wheel controlling the train. On another wheel driven by the train is a contact, which, when the clock is released, moves into contact with a fixed contact provided for the purpose, and in so doing completes the circuit in which the coils of an electro magnet operating the trip action of the circuit breaker are included.

Another form of time limit circuit breakers are operated by air pressure. In these apparatus the core of a solenoid is lifted or depressed in opposition to air or oil pressure, so arranged that it requires a definite time to overcome it, and if the short circuit is removed before this period has elapsed, the circuit breaker is not opened.

The Ferranti Alternating Current Time Limit Relay for Circuit Breakers

In this apparatus there is an electro-magnet with a core of laminated iron plates, its coils being energized by the secondary current of a transformer, the primary of which is included in the circuit to be controlled. The poles of the magnet are provided with what Mr. Ferranti has called "shading coils," that is to say, coils placed on the pole pieces, each coil closed on itself,

and the coils becoming smaller as the core of the pole piece becomes smaller.

A copper disc is pivoted between the poles of the electro-magnet, and is free to revolve, its motion being controlled by a hanging weight, and retarded by an adjustable damping permanent magnet covering a portion of its edge. The hanging weight carries a pivoted lever with a contact which, when the apparatus operates, completes the circuit of the tripping coils of the circuit breaker. When the feeder that is under the control of the apparatus has an excessive current passing through it, the copper disc is set in motion, and, in revolving, winds up the cord to which the hanging weight is attached. When the weight has been drawn up a certain definite distance, that is, when the copper disc has made a certain number of revolutions, the moving contact referred to makes connection with the fixed contact, closes the circuit of the tripping coil, and opens the circuit breaker. A certain definite period, ranging up to thirty seconds, must elapse, during which the copper disc is revolving, and gradually bringing the moving contact piece towards the fixed contact piece, before the circuit breaker can operate. If, before this period has elapsed, the overload is removed, the copper disc ceases to revolve, the weight revolves it in the opposite direction by itself, running down, the moving piece being at the same time carried away from the fixed contact piece. The relay can be set to operate with any percentage of overload that may be desired. It is usually set for a 25 per cent. overload, but it can be set for 50 or more, as required. In the working of the apparatus, the time which elapses before the circuit breaker opens the circuit is inversely proportional to the degree of overload. Thus, with a slight overload the copper disc will revolve slowly, and the moving contact will take a comparatively long time in completing the trip circuit. With a very bad short circuit the copper disc will revolve very quickly, the trip circuit will be closed in a very short interval of time, and the circuit will be very quickly opened.

Atkinson's Time Limit Circuit Breaker

In this apparatus there is a tube filled with oil, in which a metal ball is free to roll from end to end. At the end of the tube is a small chamber containing two contacts, one fixed and the other movable; the movable contact having a mica vane attached for the purpose of damping its motion. These two contacts close the trip circuit. Under normal conditions the tube is inclined at an angle slightly out of the horizontal, so that the ball remains at the end of the tube away from the contact chamber. When the overload

arrives, the tube is slightly inclined towards the contact chamber, the ball then rolls to the contact chamber, and forces the moving contact into connection with the fixed one. The time taken can be regulated between three minutes and sixty minutes, and the current between 60 and 100 per cent. overload. In the event of a short circuit, the tube is inclined so much that the weight of the moving contact is sufficient to bring it into connection with the fixed contact, the relays operating at once.

CHAPTER VI

THE APPLICATION OF ELECTRICITY TO DRIVING MACHINES, ETC., IN MINES

The Electric Motor

THERE are practically only two forms of electric motor in use at the present time suitable for mining work, the continuous current and the three-phase motors. The two-phase motor is also used occasionally, but it is practically the same as the three-phase, it having two sets of coils on the stator, with four terminals and four slip rings on one rotor in place of three. The single-phase motor, though it is being steadily developed, has not yet reached the point at which it is suitable for mining work. The continuous-current motor is the continuous-current generator, having current delivered to it from a supply of electricity, in place of being driven by mechanical power. Plate 19A shows the parts of a modern continuous-current motor. It should be noted that the mechanical power any electric motor will furnish is approximately 20 per cent. less than the power required to drive it as a generator, the machine doing full work in each case. The reason is, the work any dynamo will perform, whether as generator or motor, is limited by the current its wires will accommodate without unduly heating, and the pressure it will generate when going at a safe speed. When the dynamo is run as a generator, the charge for conversion has to be added to the output, this making the total power required to be delivered to the driving axle. When it is run as a motor, the charge for conversion is subtracted from the total electrical power delivered to its terminals. The continuous-current motor is wound just as a generator is, as series, shunt, or compound, and each form has its own properties.

The series-wound motor develops a powerful torque on starting, more powerful than either of the other forms, but its speed varies very considerably with changes of load, and it is therefore not so suitable for work where uniform speed is required or is advantageous. The reason is, the power a motor will develop depends directly upon

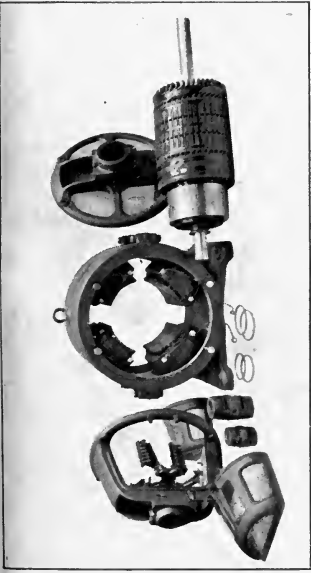

PLATE 19A.—Parts of Continuous Current Four Pole Motor,
as made by the Lancashire Dynamo Co.

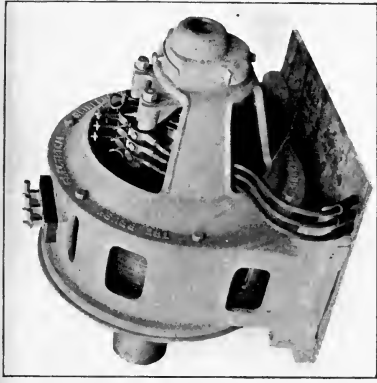

PLATE 19B.—Three Phase Motor complete,
with Connections to Starting Resistance,
made by the Brush Co.



PLATE 19C.—Stator of Three Phase
Motor.



PLATE 19D.—Wound Rotor of Three Phase Motor with
Slip Rings for connecting to Starting Resistance.
[To face p. 272.]



the strength of the magnetic field, and upon the strength of the current passing through its armature coils. When a continuous-current series-wound motor is first started, the back pressure being small, a powerful current passes through both armature and field

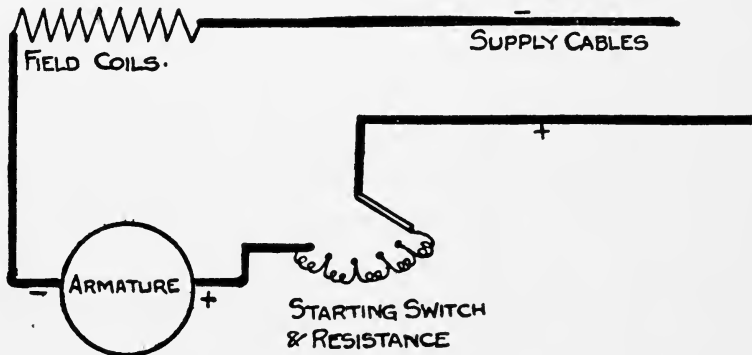

FIG. 116.—Diagram of Connections for starting a Series-wound Motor.

coils, with the result that the field is very strong, and the motor develops a powerful torque. On the other hand, with changes of load, when the machine is running normally, a decrease of load allowing it to increase its speed reduces both the current in the

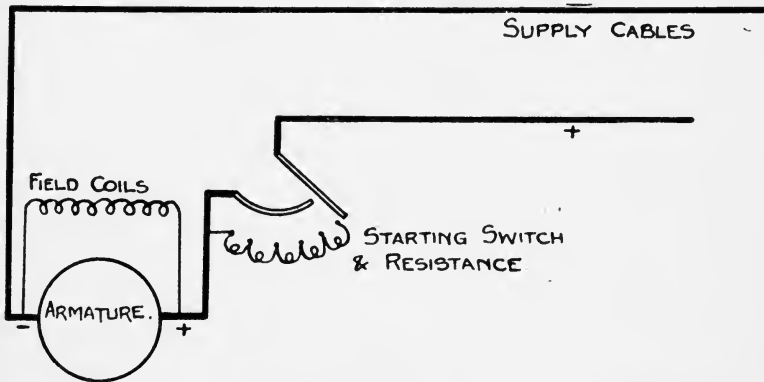

FIG. 117.—Diagram of Connections for starting a Shunt-wound Motor.

armature and the strength in the field coils, this latter causing a further increase of speed, and so on.

The shunt-wound motor gives a very nearly uniform speed with varying load. In fact, it is possible to construct a shunt-wound

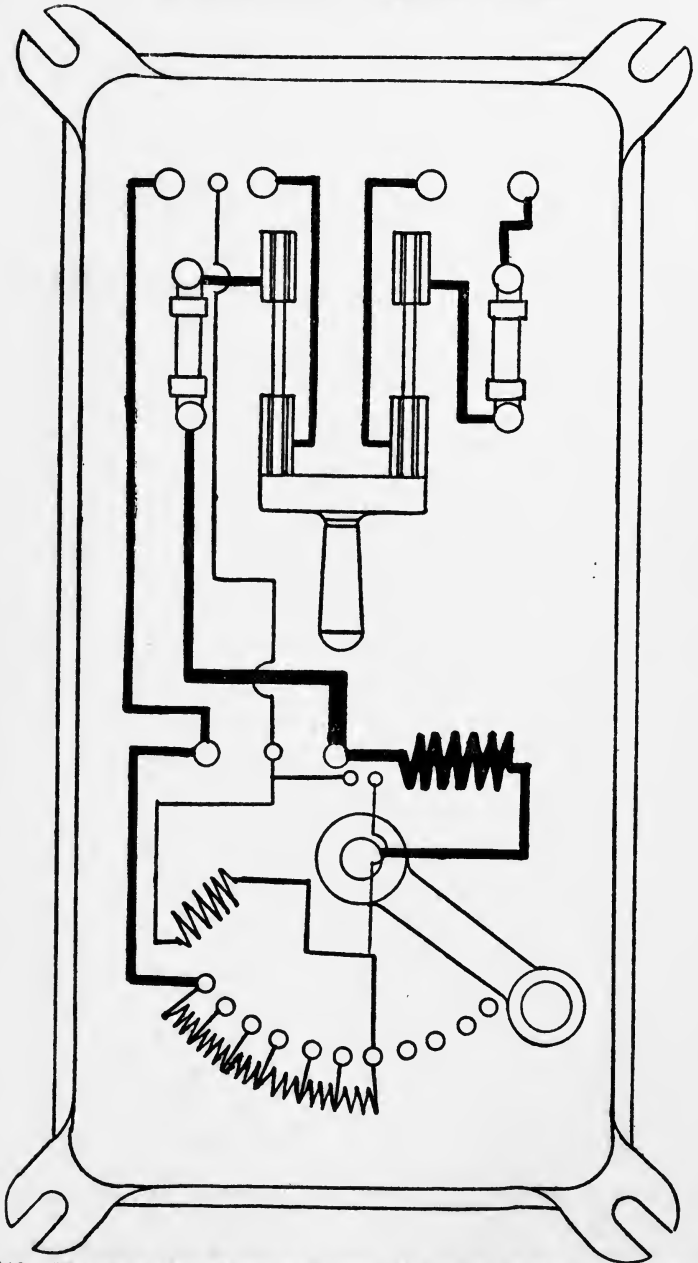

FIG. 118.—Diagram of Connections of Johnson & Phillips' Motor Starting Box, with Double-pole Switch, Fuses, and Starting Resistance for Continuous Currents.

motor whose variations of speed within a certain range shall be negligible. The shunt-wound motor is also self-governing. The electrical energy supplied to an electric motor may be divided into two portions, that which is converted into heat in the coils of the armature, and which is employed in creating the magnetic field and in overcoming the frictional resistance, and that which does useful work. Every electric motor, when running, generates a back pressure, in opposition to the pressure of the service from which it is receiving its current, and the pressure available for driving current through the coils of the machine is the difference between this back pressure and the pressure of supply. It may be taken that the back pressure multiplied by the current measures the useful work, and the difference between the back pressure and that of supply, multiplied by the current, represents the charge made for conversion. In the shunt-wound motor the full pressure of the service is delivered to the field coils, and only the small pressure necessary for driving the current through its coils, to the armature. When the armature increases its speed, as when the load is lightened, and thereby increases the back pressure, the pressure available for driving current through its own coils is lessened, and the current passing through them is also lessened, and with it the work the motor is doing. When the load is increased, the armature slightly slows, the back pressure is slightly reduced, more current passes through the armature coils, and more work is done. The pressure at the terminals of the field coils is raised and lowered when the load decreases and increases, but the difference created by this in the power converted by the motor is very small compared to the difference created by the decrease or increase of current in the armature coils. The lower the resistance of the armature coils, the more nearly constant is the speed of the shunt-wound motor with varying load, because the charge for the passage of the increased current is less, and *vice versa*.

The compound-wound motor is made in two forms. The series coils may be connected to aid the shunt coils, or to oppose them. The compound-wound motor is not much used, except where the series coils are employed to give an increased torque when the motor starts, and they are often cut out afterwards. The shunt-wound motor is weak in the matter of starting torque, and for the reason that when the motor first starts from rest, the back pressure is small, and consequently the current passing through the supply wires is large, and the pressure at the terminals of the shunt field coils is low. Hence the strength of the field is lower than it is when the motor is running normally, and very much lower than that of the series-wound motor.

With all continuous-current motors it is necessary to provide starting gear, consisting of a resistance which is inserted in the

armature and field circuit in the case of the series-wound motor, and in the armature circuit alone in the case of the shunt-wound motor.

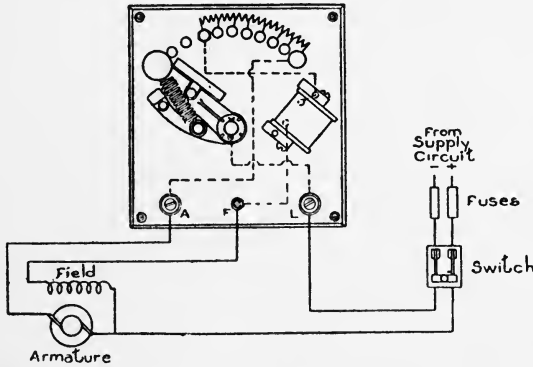

FIG. 119.—Diagram of Connections of the B. T. H. Co.'s Form A Rheostat for starting Shunt-wound Motors, with no Voltage Release. When the Pressure falls below a certain Figure, the Electro Magnet releases the Contact Bar.

free passage of air to the surface of the conductive resistance. The

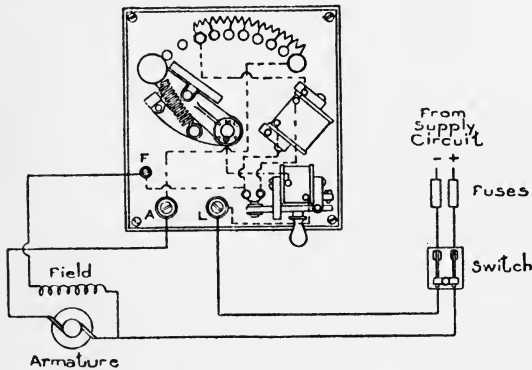

FIG. 120.—Connections of the B. T. H. Co.'s Form A Starting Rheostat for Shunt-wound Motors, with no Voltage and Overload Release. The Handle shown on the Left is held against the Upper Electro Magnet on the Right when the Motor is running, and is released by the Coils of the Electro Magnet being short circuited in either Event, Overload or no Pressure.

Figs. 116 and 117 are diagrams of connections for starting series and shunt-wound generators. Figs. 118 to 122 are diagrams of connections of various motor-starting apparatus. The starting gear consists of a resistance which may be of metal, such as a wire or a strip coiled into different forms, and held in any convenient arrangement, such as inside a perforated metal box, the object being to allow

the resistance is also made in the form of a liquid, such as sulphate of soda, held in an iron trough with an iron wedge-shaped plunger arranged to be pushed into the liquid. In either case when the motor is started, the full available resistance is thrown into circuit, and it is gradually cut out, section by section, as the motor gets up speed. In the case of the shunt-wound motor the current is first switched on the field coils, and then after a

short interval it is switched on to the armature coils, through the resistance. Where a liquid resistance is employed, it is gradually cut out

by forcing the plunger more and more into the liquid, till it finally makes contact with the trough containing the liquid, at the bottom. In a form of liquid-starting resistance which has been developed on the Continent, in the first instance for electric railway locomotives, and later for mining work, the metal electrodes are fixed permanently inside of containing vessels, and the liquid is forced up by compressed air through a hole in the bottom of the containing vessel, the height to which the liquid rises varying the resistance offered, in the same manner as with the distance to which the wedge-shaped electrode is immersed. One

form of liquid-starting resistance is shown in Plate 21A. An important point in connection with all electric motors is, they must not be started too quickly; that is to say, the resistance must not be switched out too quickly. The reason is, in addition to the fact that a certain time is required for the armature to start from rest, when a powerful current is passing through the armature coils, the field which it

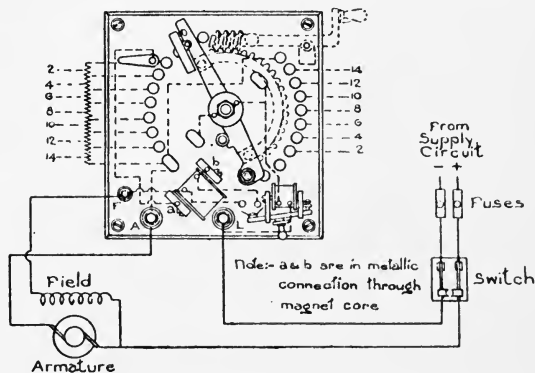

FIG. 121.—Diagram of Connections of the B. T. H. Co.'s Form B Starting Rheostat for Shunt-wound Motors, with Overload and no Load Release. The Contact Lever, it will be noticed, is worked by the Worm and Wheel shown instead of directly by Hand, as in Form A. The Contact Bar is held by Magnetic Attraction to the Electro Magnet on the Left when the Motor is running, and is released by the Magnet Coils being short circuited in Case of Overload, and directly weakened with no Voltage.

distance to which the wedge-shaped electrode

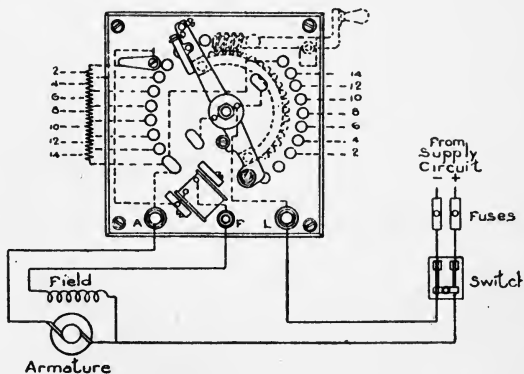

FIG. 122.—Diagram of Connections of the B. T. H. Co.'s Form B Rheostat for starting Shunt-wound Motors with Overload Release only.

the field which it

creates tends to neutralize and to overpower the field created by the field magnet coils, with the result that it is possible to have conditions under which the motor cannot start, because there is no appreciable field to create motion in the armature conductors. There are several forms of apparatus on the market in which the attendant is not allowed to switch on too quickly. In particular, he is obliged to dwell a certain time on the first stop, so that the field magnets in the case of the shunt-wound motor may become thoroughly energized. Messrs. Reyrolle have worked out a starting

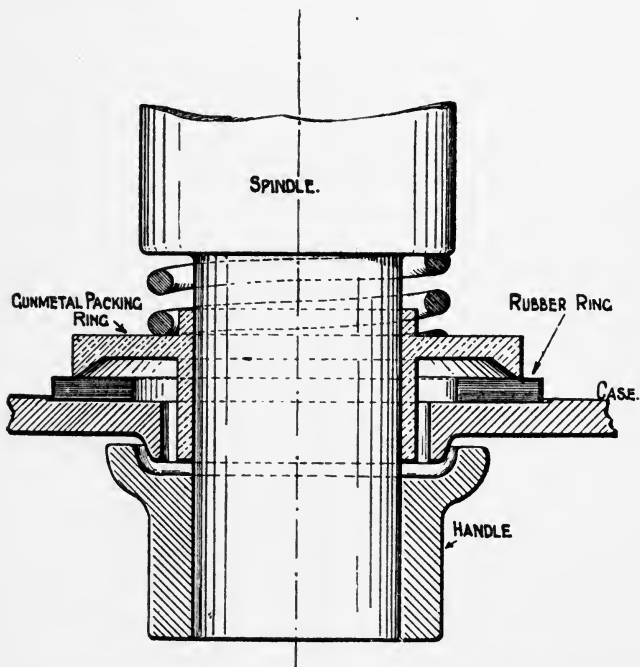

FIG. 123.—Section of Messrs. Reyrolle's Packing Ring for Gas-tight Motor Starters.

resistance shown in Plates 20A and 20B, in which the passage of the current lowers the resistance. Fig. 123 shows the arrangement adopted by this firm for preventing gas penetrating to the starting contacts. Plates 21B and 22A and 22B show motor-starting panels for use in mines, and Plate 21C an oil-enclosed switch for use in bye.

The three-phase motor is very similar to the continuous-current motor in appearance, and it is very similar to the three-phase generator in many respects. There is the same iron or steel containing cylinder as in the majority of continuous-current motors, but in

place of the field poles extending radially inwards of the continuous-current motor, there are the slotted discs held on the inside of the cylinder, just as in the armature of the three-phase generator with rotating field magnets. The slots in the discs accommodate the windings of the two or three sets of coils, according as the motor is arranged to work with two- or three-phase currents, and the cylinder with its discs and coils is known as the "stator." The "rotor," as the moving member of the two- and three-phase motor is called, corresponds to the armature of the continuous-current motor, and is very similar to it up to a certain point. There are the same slotted discs on a spider sleeve keyed on the rotating shaft, and the coils are wound or fixed in the slots as in the continuous-current armature. But it has no commutator, and in this respect is simpler than the continuous-current motor, and less liable to get out of order, the commutator being one of the great sources of trouble, especially where a motor is employed under conditions such as those that rule in mining work. There are two forms of rotor, known as the "squirrel cage" and the "wound" rotor.

The squirrel-cage rotor has conductors embedded in the slots in the periphery of the iron core, the ends of the conductors at both ends of the core being joined by circles of copper, the whole forming an apparatus very similar to the cage that squirrels are made to perform in. In the wound rotor the coils are wound in two or three sets, according as the machine is for two or three phases, and they are fixed in the slots very much in the same way as the coils of a continuous current motor; but it is arranged that when the motor is being started, the ends of the coils are brought out to slip rings on the rotor shaft, against which brushes bear, adjustable resistances being connected to the brushes. The squirrel-cage rotor is started either by simply switching the stator coils on to the supply service directly, or by using an "auto-transformer," an apparatus which transforms the pressure of supply down to a low figure, so that the currents passing in the stator coils and the currents induced in the rotor coils are small, until the rotor has got up speed, when the full pressure of supply is switched on. An auto-transformer is merely a small transformer enclosed in a box which may be fixed in any convenient position, and which has a double throw switch on the top, one set of contacts connecting the low pressure, the other set the full service.

With wound rotors, the motor is started very much in the same way as the shunt-wound continuous-current motor. The supply pressure is switched on to the stator coils, and at the same time the full resistance is connected to the rotor coils, and is gradually switched out as the rotor gets up speed, the rotor coils finally being short circuited, in a similar manner to those of the squirrel cage. Fig. 124 shows the connections for this, and Fig. 125 is a diagram of

the connections of a Westinghouse three-phase motor starter. The reason for employing the auto-transformer, and the resistance in the case of the wound rotor, is that which was given for the continuous-current motor. If the full current is allowed to be induced in the rotor coils that would be induced, when it starts from rest if the full pressure were applied to the stator coils, the magnetic fields created by the current in the coils of the rotor would overcome the fields created by the currents in the stator coils. The behaviour of the two- and three-phase "induction" motor, as it is called, or asynchronous motor, is very similar in almost every respect to that of the shunt-wound motor, though the reason for its behaviour is different.

In the induction motor the field created by the currents in the stator coils is not stationary within the cylindrical space occupied by the rotor, but is continually moving around it, as the currents in the

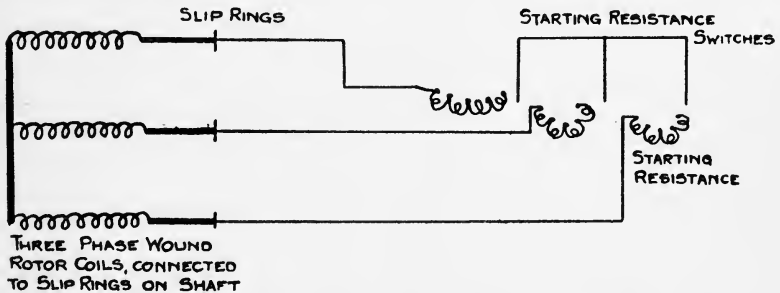

FIG. 124.—Diagram of Connections for starting Three-phase Motors with Wound Rotors.

different phases rise and fall and reverse, and the variations in the currents in the stator coils induce currents in the rotor coils in such directions, that the coils and the iron core to which they are attached move round after the magnetic field created by the stator coils. The rotor never attains the same speed as the stator coils it is moving after, just as the armature of the shunt-wound motor never creates a back pressure equal to the supply pressure. If the back pressure of a continuous-current motor equalled the supply pressure, no current would pass, and the efficiency of the system would be 100 per cent. Similarly, if the speed of the rotor equalled that of the revolving field created by the stator currents, no current would pass, and the efficiency of the system would again be 100 per cent. But no motor is without friction, and all motors make a charge upon the energy delivered to them for creating the magnetic field, hence there is always a difference between the supply and back pressures in continuous-current machines, and between the speed of the field and that of the rotor in



PLATE 20A.—Messrs. Reyrolle's Starting Switch and Resistance complete in iron case. The Motor is started by turning the Wheel at the Top.

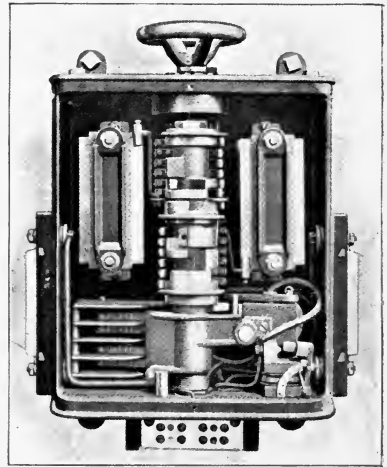

PLATE 20B.—Internal Construction of Messrs. Reyrolle's Starting Switch and Resistance. The Resistance is lowered by the Passage of the Current through it, hence the Current automatically increases.

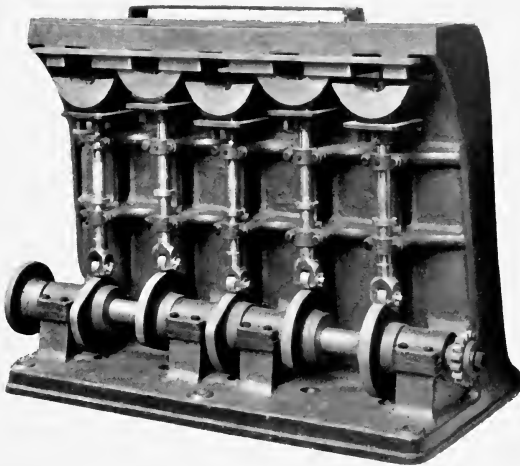

PLATE 20C.—Reversing Apparatus, for Electric Winding, made by the International Electrical Engineering Co., of Liege. The View shows the Inside of the Case in which the Connections are made.

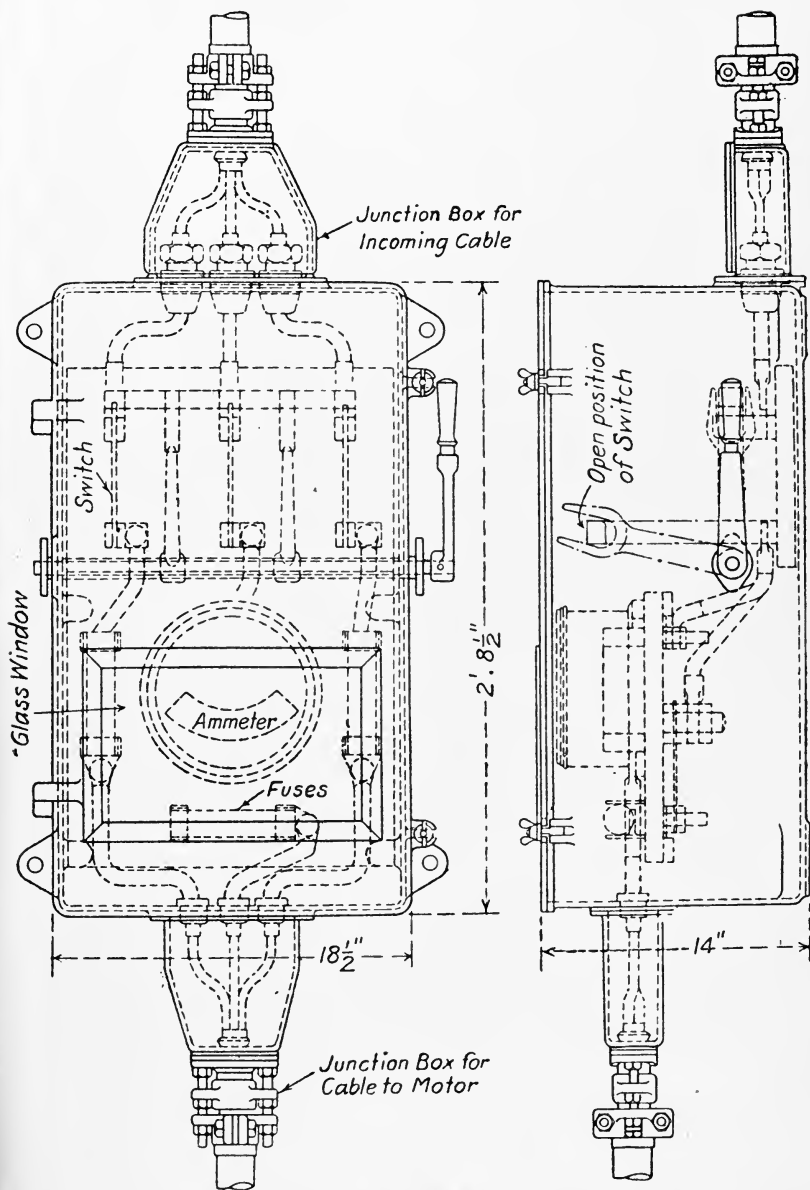

FIG. 125.—Diagram showing Connections and Arrangement of Westinghouse Three-phase Motor Starting Box.

induction motors. Further, just as the current required to turn the armature of the continuous-current motor increases or decreases according as the speed of the armature falls or rises, so the currents induced in the rotor of the induction motor increase or decrease as the speed of the rotor decreases or increases, the speed decreasing with increased load, and increasing with decreasing load. The induction motor is practically self-governing within its own limits, just as the shunt-wound motor is. An increased load causes the motor to slightly slow up, this allowing the necessary increased current to be induced in the rotor coils. The induction motor is really a rotary transformer, the stator coils being the primary, and the rotor coils the secondary, and just as in the ordinary stationary transformer the currents in the primary induce pressures in the secondary, so the currents in the secondary induce currents in the primary. Plates 19B, 19C, and 19D show a complete three-phase motor, and its "stator" and "wound" rotor; and Plate 22c shows a "wound" rotor, with slip rings apart from the bobbin.

Methods of varying the Speed of Electric Motors

With continuous-current motors there are two methods of varying the speed, by varying the pressure delivered to the terminals of the

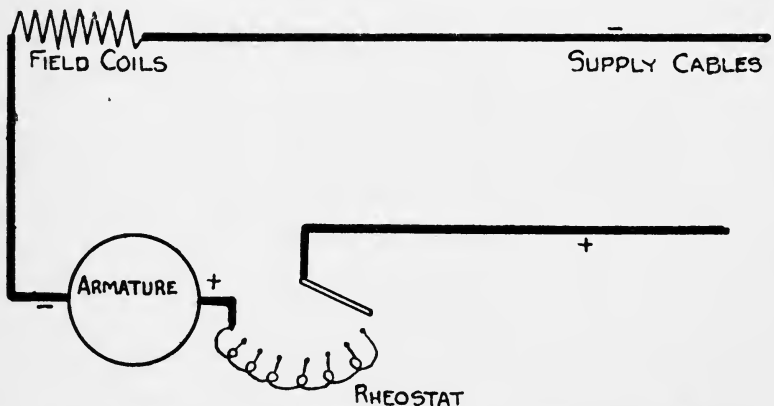

FIG. 126.—Diagram of Connections for regulating the Speed of a Series-wound Motor by varying the Pressure. The Resistance absorbs more or less of the Pressure of Supply. It will be noticed that the Connections are similar to those for starting a Series-wound Motor. It is the Resistance that must be different.

motor, and by varying the strength of the current passing through the field magnets. With the series-wound motor, the most convenient

method is by varying the pressure delivered to the motor, and this is done by inserting a resistance between the positive supply cable and the positive terminal of the motor, the resistance being divided into sections similar to that of the starting resistance, and more or less of it being thrown into, or cut out of, the circuit by means of a switch. A diagram of this is shown in Fig. 126. One important caution is necessary here, the neglect of which has led to trouble in the past. The resistance which is arranged to be thrown into the circuit of a motor on starting is not designed to carry the current the motor will use when doing its work. In the case of the starting resistance, the current is only allowed to pass through the conductor or the liquid for the very short period occupied in starting, and as the time factor is of enormous importance in this case, the heat liberated by the current is so small comparatively, while with a properly designed resistance the heat passing away from the resistance is so large comparatively, that the temperature of the apparatus should not be appreciably increased. For this reason very much smaller metallic or liquid resistances can be employed than would be possible if the current is allowed to pass through it continually. Where a resistance is employed to vary the speed of the series-wound motor, therefore, by varying the pressure, that is by using up a portion of the pressure that would be delivered to the motor, the resistance must be calculated of such a section, whether liquid or metallic, and the means of dissipating the heat generated must be such that the rise in temperature does not exceed that of a generator or motor when in regular use. If this condition is not observed, trouble will arise with the resistances.

With metallic resistance any joints there may be—there should be no joint in the resistance at all, if possible—and the connections to the stops forming the sections of the resistance, will be very likely to become disconnected, arcing following, and trouble generally. With liquid resistance evaporation always takes place, both when the current is passing and when it is not. The evaporation will be greater than when the current is passing, because of the heat delivered to the liquid and the higher temperature to which the liquid is raised, that is to say, the greater the current that is allowed to pass through the liquid the greater will be the rate of evaporation. And this leads to two forms of trouble; not only does the vessel containing the liquid require very frequent replenishment with water, but the liquid itself changes its physical properties. Its resistance will change, and the result of interposing a smaller or larger quantity in the circuit will also be changed. It is, however, perfectly practicable to provide either a metallic or a liquid resistance that shall answer all the conditions required for regulating the speed of a series-wound motor, but though the plan is a convenient one,

providing the resistance is properly arranged, it is a very wasteful one if the motor is working for any period at anything much less than its full load, since the whole of the electrical energy that is converted into heat in the controlling resistance is absolutely wasted, and tends to raise the temperature of the apparatus generally.

The other method with a series-wound motor is, by providing a shunt to the field coils, dividing the shunt into sections, just as with the starting resistance and the series controlling resistance, and shunting the field coils by a greater or less portion of the shunt, according as the speed of the motor is required to go down or up, as shown diagrammatically in Fig. 127. It should, perhaps, be mentioned

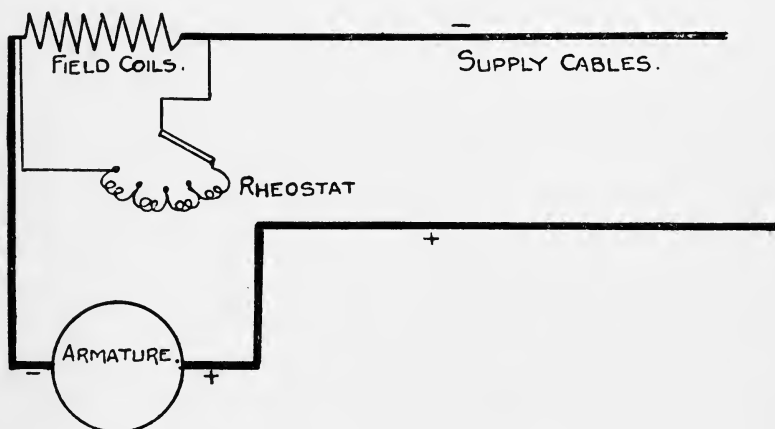

FIG. 127.—Diagram of Connections for varying the Speed of a Series-wound Motor by varying the Field Current. The Resistance shown shunts more or less of the Normal Current.

that lowering the pressure delivered to the terminals of the series-wound or shunt-wound motor by the insertion of resistance in the main circuit, lowers the speed of the motor, and that shunting the field coils of the series-wound motor, lessening the current passing through the field coils, raises the speed of the motor.

With a shunt-wound motor a variable resistance may be fixed in the main circuit, or preferably in the armature circuit only, just as with the series-wound motor, but the more common arrangement is, a variable resistance is inserted in the circuit of the field coils, as shown in Fig. 128. Increasing this resistance increases the speed of the motor, and *vice versa*. It will be seen that the method of lowering the field current is preferable to that of lowering the pressure in the main circuit, inasmuch as though there is a certain waste in the

resistance, the waste is very much smaller than where the resistance is added to the main circuit. There is a limit, however, to the application of the method of adding resistance to the circuit of the field coils of the shunt-wound motor. As the field is weakened, and especially if, as is required in many cases, the current through

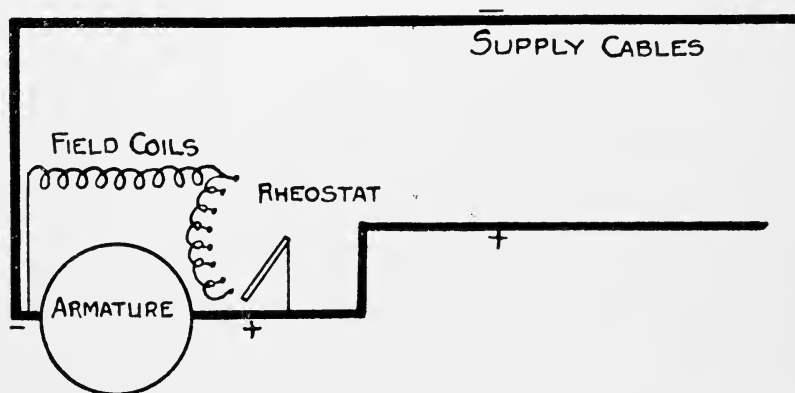

FIG. 128.—Diagram of Connections for regulating the Speed of a Shunt-wound Motor by varying the Field Current.

the armature is increased, so that additional work may be done by the motor, sparking commences at the brushes, and increases, notwithstanding what can be done by the brush rocker, until at about 25 per cent. above the normal speed no further increase is possible.

The Motor with Commutating Poles

The trouble, however, mentioned above has been completely overcome by what is known as the dynamo with commutating poles, described in Chapter IV. Commutating poles are additional field magnet poles, smaller than the proper poles of the machine, and fixed between them in such a position that they neutralize the current generated in the coil passing under the brush at the moment of commutation. By their aid the speed of shunt-wound motors may be varied in the rates of one to six, by varying the current passing in the field coils, and without sparking. This method is being used very largely for driving machine tools and other apparatus, where large variations of speed are required.

Varying the Speed of the Three-phase Motor

The speed of the three-phase motor, as explained above, is controlled by the speed of the revolving field, and this again is the periodicity of the service. Hence, one method of varying the speed of a three-phase motor is by varying the number of poles of the stator, and thereby varying the speed of the revolving field, and with it the speed of the motor that is moving after it. The range, however, of variation of speed by this method, it will be seen, is small. With small machines, for instance, having six or eight poles in the stator, cutting out half reduces the speed one-half, and so on. The method more frequently adopted is by adding a resistance to the rotor circuit, similar to that arranged for starting the wound rotor, and making this resistance sufficiently large, etc., to be allowed to remain in circuit for any period that may be desired when the motor is at work. It need hardly be said that this method is wasteful, but in certain cases, as will be described, it is, perhaps, the best available. There are signs that apparatus for varying the frequency of a service are being worked out, and probably some arrangement of the kind will be adopted for controlling the speed of three-phase motors.

Electrically Driven Pumps

Driving pumps by means of electric motors was the earliest application of electricity to power purposes in mines, the first having been at Trafalgar Colliery in the Forest of Dean, by the late Mr. William Blanch Brain. Mr. Brain had a good deal of water in some of his workings, at some distance from the pit-bottom, and he had been driving a pump by steam taken down the pit. He fixed a Siemen's machine of those days that was capable of furnishing one arc lamp, to drive the pump by means of a belt, and he fixed an "A" gramme machine, the 1500 to 2000 watt machine of those days, in an engine house on the bank, and drove it by means of a single cylinder engine. Both generator and motor were series wound. The arrangement answered remarkably well, and the quantity of coal saved was something very considerable. In addition to the cables connecting the two machines, there was also a telephone fixed in the engine house, with a battery and a pair of wires which were led to the pump house, connected to a moving contact which completed the circuit at every stroke of the pump, so that the attendant in the engine house could hear if the pump was working satisfactorily. Pumping is a particularly suitable class of work for electric driving, for the principal reason that the pumps are very often required to

be at some distance from the shaft bottom, and in out-of-the-way positions; and it is much easier to run a pair of cables to these positions, than either a steam, compressed air, or hydraulic pipe. Where dip pumps also are employed, the arrangement of the pump fixed on a trolley with its motor, gearing, and starting switch, the trolley being mounted on wheels to run on the mine roads, is very convenient, as it is easy to provide a sufficient length of cable on drums fixed on the trolley, to enable the pump to follow the water right down without making joints, and without any change in the resistance of the leads. Electricity has, however, been applied to pumping in mines under every condition where pumping is required. It is employed in sinking pumps, in driving pumps at the bottom of the shaft when the water from the workings has been delivered to a sump there, for dip workings, for pumping water from rivers, for boiler feed, etc.

Forms of Pumps

There are three forms of pumps employed in mines, centrifugal pumps, ram or plunger pumps, and bucket pumps. Of these the ram pump in its three-throw form is the one most commonly employed; but since the improvement that has taken place within recent years in the centrifugal pump, this is also making way. The bucket pump is only employed, so far as the author is aware, for pumping from sumps or lodges in the mine shaft. The centrifugal pump is the opposite of the water turbine, with certain modifications. In the water turbine there are a number of blades arranged around a shaft, and the water impinging upon them turns the shaft, to which they are attached. In the centrifugal pump there are again a number of blades surrounding a shaft, and when the shaft and its blades are revolved by mechanical power from outside, the water which is made to enter the pump at the centre is forced outwards by the action of the blades, and by its own centrifugal force, and is driven into the delivery pipe. The earlier forms of centrifugal pump were only available for very low lifts, 50' being considered high, and while the efficiencies were comparatively high with very low lifts, they fell very quickly if the lift was increased. Modern centrifugal pumps, however, deal with lifts as much as 2000', and it is claimed that the efficiencies are higher than those of the ram pump. Improvement in the efficiency of the centrifugal pump has been obtained by a careful study of the course of the water in the pump. Power is wasted in every pump by eddies that are created in the water, and by a study of the form which these eddies take, and by designing the pump so that no eddies are made, the efficiency

has been increased. One great trouble in the centrifugal pump which led to its previous inefficiency was, the water in passing through the pump was going at a very high velocity, and when delivered from the pump into the rising main, it met and had to be absorbed by a column of water which was moving at a very much slower rate, and this led to the formation of a number of eddies, and back pressures, opposing the onward motion of the water, and absorbing a part of the power that was being delivered to the pump shaft.

Pump makers express the fact sometimes by saying that the difficulty is in converting velocity head into pressure head. They mean what the author has expressed above. The water when in rapid motion is possessed of a certain quantity of energy in virtue of its velocity. It is known as kinetic energy. When it joins the slowly moving column, it does not lose the energy that was imparted to it, except in so far as it may be deprived of a portion of it by the eddies and back pressures that are formed; and what is really required is, the conversion of the high rate of motion to the slow rate of motion, without loss of energy. In the older form of centrifugal pump, the water when leaving the fan blades was delivered into a whirling chamber, where it was at liberty to form as many eddies as it pleased, and from which it was finally pushed out by the pressure of the water behind it, but with a considerable expenditure of unnecessary power. In the modern centrifugal pump the water is guided after it leaves the fan blades by various devices, by guide vanes in the Worthington turbine pump (Fig. 129 shows a section of the Worthington Co.'s multistage centrifugal pump); by a guide ring in the Mather & Platt centrifugal pump; and by other arrangements, all very similar, by other makers. In all cases the object to be attained is the avoidance of shocks, the avoidance of the impingement of the water against dead surfaces of metal or water, and the gentle guidance of the water by curved passages, carefully calculated for the purpose, so that its velocity is gradually lost, and when it joins the rising column, the energy with which it left the vanes has been converted to the form in which it will best assist to push the column above it upwards.

Centrifugal pumps are now made in three forms, for very low lifts up to 30', for medium lifts up to 70', and for high lifts up to 100 and odd feet, and any of these forms may be connected together in series, their lifts then being added together. The speeds of the pumps for the different lifts do not differ very much. With each form of pump, and with each size, there is a certain speed at which the highest efficiency is obtained, there is a certain quantity for the highest efficiency, and a certain head. Larger quantities may be delivered by any given pump by driving it at a higher speed. Any given quantity may be raised to a greater height, also by increasing

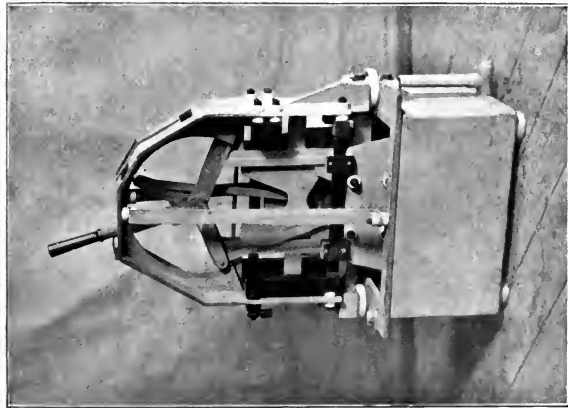

PLATE 21A.—Messrs. Dorman & Smith's Liquid Starting Resistance. Moving the Lever to Right or Left, raises or lowers the Plates.

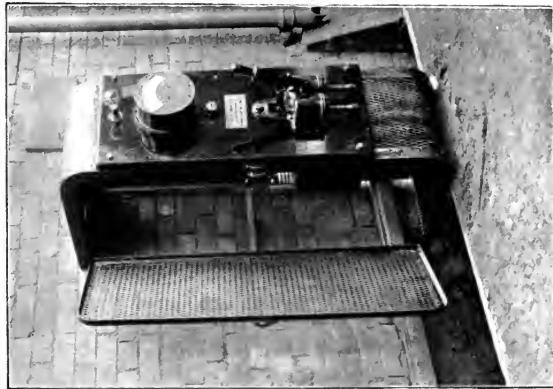

PLATE 21B.—Motor Panel with Circuit Breaker by Messrs. Reyrolle.



PLATE 21C.—Messrs. Reyrolle's Oil Enclosed Mining Switch.

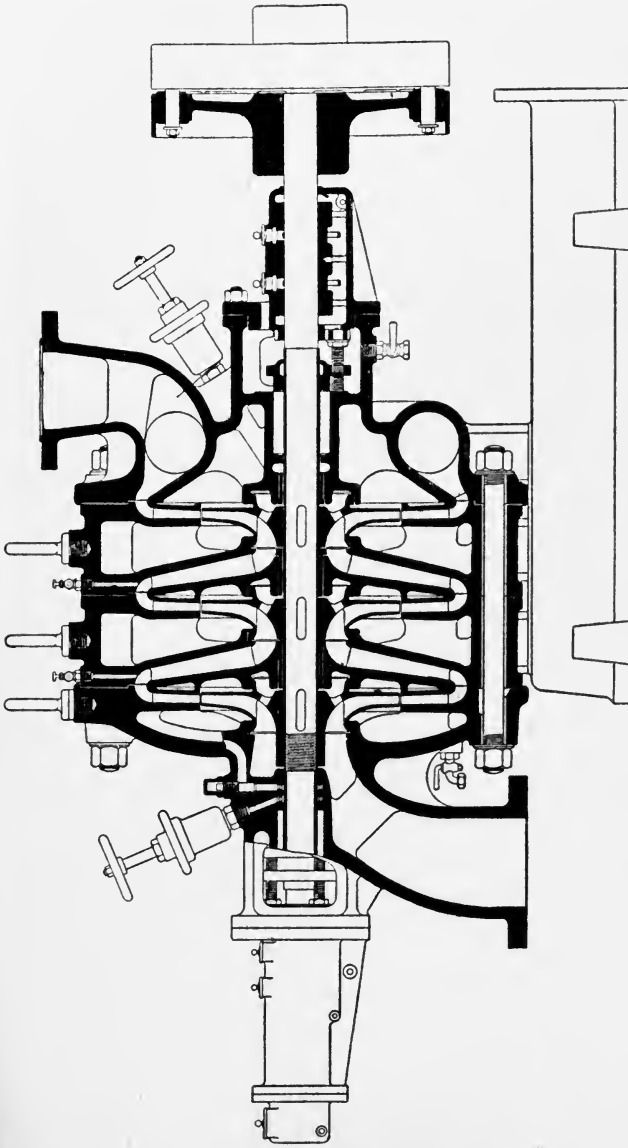

FIG. 129.—Section of Worthington Centrifugal High-lift Multistage Pump, showing the Arrangement of the Water Leads.

the speed, but the efficiency goes down very quickly after the quantity is reached for which the pump is constructed. Figs. 130

and 131, which are curves taken by Messrs. Mather & Platt from a single chamber pump, constructed for the Newcastle Corporation Electricity Works, to deliver 1250 gallons of water per minute against a head of from 100' to 117', the pump running at 700 revolutions per minute, show these points very clearly. It will be seen from Fig. 130, in which the quantity pumped was maintained constant, that the efficiency rises very quickly from nothing, as the revolutions of the pump increase, till at 650 revolutions the increase of efficiency is very gradual. From 700 to 750 revolutions there is practically no change. At 800 revolutions the efficiency is slightly lower, and after that it falls very quickly, till at 970 it is only 42 per cent., the

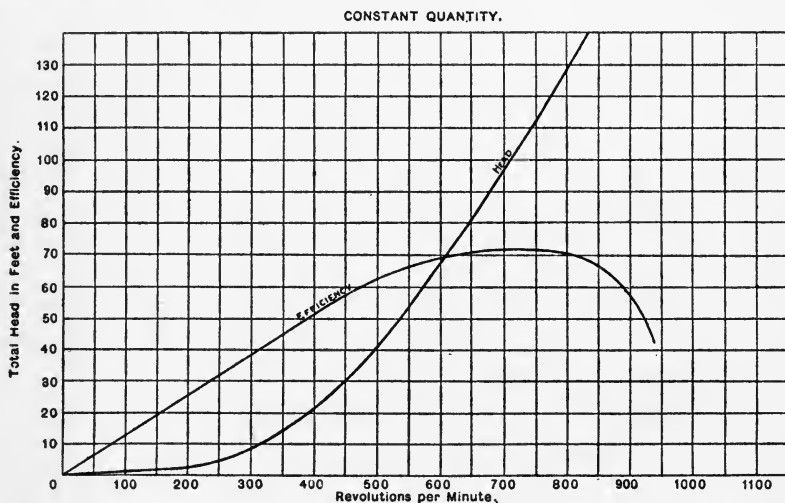

FIG. 130.—Efficiency Curve of a Centrifugal Pump, made by Messrs. Mather & Platt, with Constant Quantity and Varying Speed and Head.

highest efficiency being about 72 per cent. When running at constant speed, as shown in Fig. 131, it will be noticed again that the efficiency increases very rapidly as the quantity of water delivered increases, up to 1000 gallons per minute, then the increase is slow. There is very little change between 1200 and 1300 gallons. At 1400 gallons it falls slightly, and afterwards it falls very quickly, until at 2020 gallons it is only 25 per cent. When the head pumped against is maintained constant, the speed and the quantity being changed, the speed remains practically the same, about 680 revolutions, until the quantity is 900 gallons per minute. The speed and the quantity then go up together, the speed being 870, when the quantity is about 2350. The efficiency rises very quickly, as before, until the

quantity is 1100 gallons per minute, and the speed slightly over 700; it then rises very slowly, there being very little difference between 1300 and 1400 gallons, and between 720 and 725 revolutions, it falls slightly at 1600 gallons and 745 revolutions, and then falls very rapidly till at 2300 gallons, and at 860 revolutions, it is only 20 per cent. The moral of the above is, that it is wiser to run centrifugal pumps at constant speed for constant quantity, and at the speed and for the quantity at which they are designed to give their highest efficiency. It is usually wise to work most machinery about mines at a lower output than they are made for, because it lowers the repairs bill. With the modern centrifugal pump it will

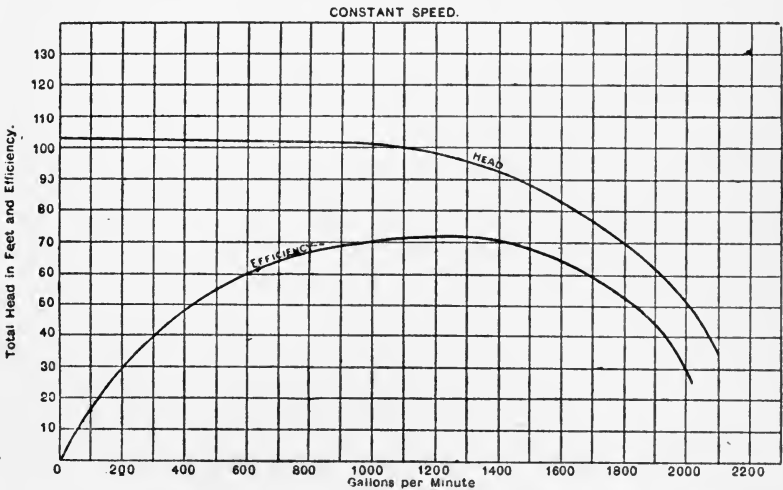

FIG. 131.—Efficiency Curve of a Centrifugal Pump, made by Messrs. Mather & Platt, with Speed Constant and Quantity and Head varying.

be seen that the output can be lowered something like 25 per cent. with a lowered efficiency of only about 4 per cent. Plate 23A shows a single chamber centrifugal pump driven by an electric motor.

When centrifugal pumps are arranged in series, the delivery of the first pump becomes the suction of the second, the delivery of the second the suction of the third, and so on, as many as twelve pumps having been connected in series in this way, the axles of all the pumps being connected together. It will be evident that the centrifugal pump lends itself to electric driving, for two reasons: The speed of the pump is within the same range as the ordinary speed of the electric motor; and the pump, whether single or in series, can be mounted on a bedplate, on which room is left for the motor, the

axles of the pumps being connected mechanically to the axle of the motor. Further, there is no difficulty in arranging an electric motor and a centrifugal pump vertically one above the other, their axles being vertical, and the whole being suspended, say in a shaft, or any other position where space or convenience makes this arrangement suitable. Sinking pumps are worked on this plan, as shown in Plates 24A and 25A. Like the electric motor itself, the centrifugal pump is very convenient, and for that reason is suitable for a great many places where it would be difficult to apply either of the other forms.

The motor that is most suitable for driving centrifugal pumps will be either the shunt-wound continuous-current motor, or the three-phase motor. Both of these run at nearly uniform speed, the variations from the normal speed being only four per cent. in the case of the three-phase motor, and very small in the case of the shunt-wound motor under ordinary working conditions. The centrifugal pump would, in the great majority of cases, only be applied where a uniform speed would rule, since the efficiency of the pump is considerably lowered if it is run at much above or below its normal.

Ram Pumps

The ram, or plunger pump, consists of a barrel in which a ram or plunger moves to and fro. The barrel has inlet and delivery valves, the suction stroke of the plunger opening the inlet valve and sucking the water into the barrel, the delivery stroke closing the inlet valve, opening the outlet, and driving the water through it into the rising main. In mining work it is usual to arrange three pumps with their plunger rods on one crankshaft, the cranks being 120° apart, the crankshaft being driven by any convenient source of power. For electric driving it is usual to mount an electric motor on the same carriage as the pump, and to gear it either directly to the crankshaft by two spur gear wheels, or to interpose a second motion shaft, supported on the same carriage, driven from the electric motor by a belt or ropes, the second motion shaft driving the pump shaft by gearing. One of the difficulties in connection with the driving of the three-throw pump by means of an electric motor is, the great reduction that has to be made in the speed. The ordinary form of three-throw ram pump rarely runs at more than 40 revs. per minute, while the electric motor runs at from 500 to 1500 revs., according to its source.

The low speed of the pump is due to the form of the valves employed. They are usually of the mushroom type, and each time that each valve opens, the mass of metal of which it is composed has to be moved inwards or outwards against the pressure of a strong

spring. If the pumps run at a higher speed than that mentioned, 40 revs., or thereabouts, the motion of the valves becomes so rapid, and the hammering on the valve seats is so hard, that the pump is quickly put out of order. Hence, the efficiency of the ordinary three-throw ram pump is only $66\frac{2}{3}$ per cent. at its best, and when running at its highest possible speed, and from this has to be subtracted the efficiency of the gearing.

Modern ram pumps, however, have been very greatly improved, principally in Germany. Professor Riedler, who has investigated the matter scientifically, has introduced some considerable improvements, which have enabled pumps to be run at a very much higher speed, and also their efficiency to be considerably increased. An important feature in the Riedler pump is the shape and arrangement of the suction and delivery valves, as shown in Fig. 132. They are both made comparatively large, and they are made to open mechanically, the arrangement for opening them being quite independent of the pressure inside the pump chamber, so that springs are entirely dispensed with. The valve also is opened comparatively widely, so that, it is claimed, the eddies in the water are avoided. The speed is raised from 40 revs. to 150 revs., and the efficiency is claimed to be raised from $66\frac{2}{3}$ to 90 per cent. It is usual in the express Riedler pump to have only one pump chamber, with one set of valves, one set of journals, and so on, the friction saved in the lessened number of valves, etc., making up part of the increased efficiency of the pump. It will be understood, of course, that the pump deals with a smaller quantity of water at each stroke than the slow-speed pumps. In addition to this, a valve known as the "Gutermuth," the invention of the professor of that name, which is shown in Fig. 133, has been also introduced in Germany, and to this country, which it is claimed increases the efficiency of the ram pump for two reasons. The work of raising the valve is considerably lessened, and the formation of eddies by the water after passing through the valve is often, it is claimed, almost suppressed. The valve, as will be seen from the drawings, consists of a strip of steel or gun-metal, rolled up into the form of a spiral, as shown, the end of the spiral being placed across the valve port, and the rod on which the spiral is formed being held conveniently near. The operation of opening the valve consists simply in forcing the end of the steel or gun-metal plate outwards. That is to say, in the case of the suction valve, the end of the plate moves inwards into the cylinder, and in the delivery valve it moves outward into the delivery pipe, in each case winding the spiral up a little more. It will be seen that the power required to lift this form of valve may be much less than that required to lift the heavy clack valves usually employed. Further, it is claimed by Professor Gutermuth, that when the mushroom valve opens, the water passing through

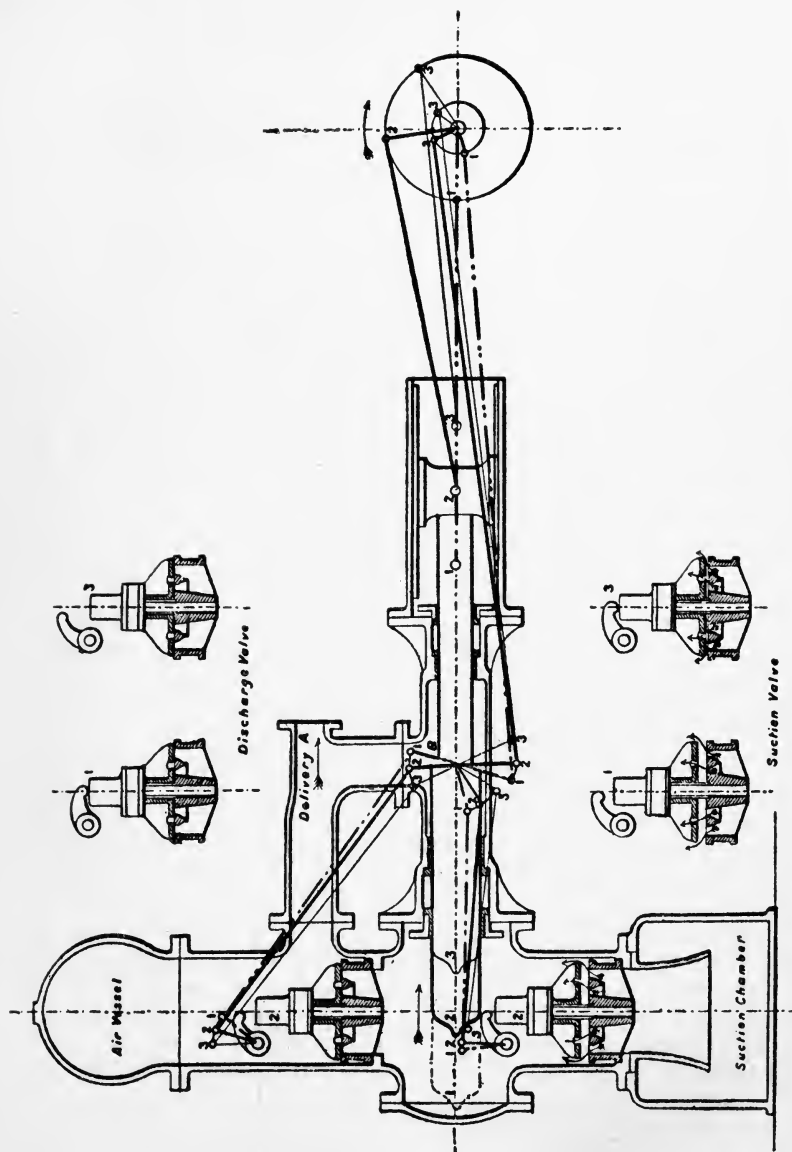

FIG. 132.—Section of Riedler Differential Pump and Valves.

the valve is forced against the head of the valve, and is broken up, forming eddies, etc., beyond, while with the Gutermuth valve the

water continues its passage in a straight line. The Gutermuth valve has been adapted to existing ram and other pumps, with the result

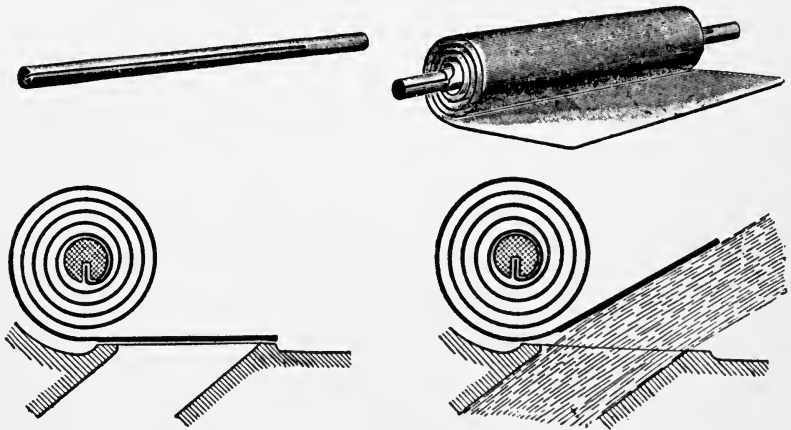

FIG. 133.—Gutermuth Valves for Pumps. The Illustration on the Right at the Top shows how the Valve is made. That on the Left at the Bottom shows the Valve in Position, and that on the Right the Water passing through.

that the travel of the pump has been increased from 40 to 140 revs. per minute, and the quantity of water, in the case of a pump of 5-inch bore by 10-inch stroke, has been increased from 1500 to 5500 gallons per hour, the valve space being increased from 4 square inches to $8\frac{1}{2}$ square inches. The arrangement of the valves is shown in Fig. 134.

The series-wound motor has been largely employed for driving the ram pump, mainly because of its high starting torque. To start the pump from rest against the pressure of a column of water, extending, say, from the dip workings to the bottom of the shaft and

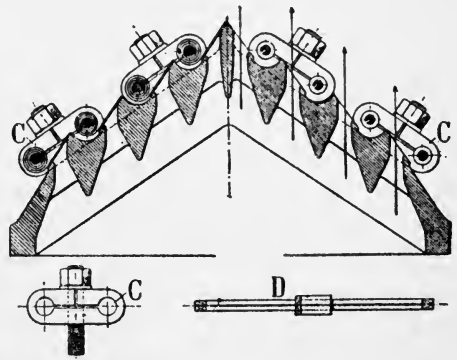

FIG. 134.—Arrangement of Gutermuth Valves on an ordinary Ram Pump. The Number of Small Valves take the Place of a Single Mushroom Valve.

thence to the surface, requires a very considerable starting effort, though the power required when once the pump is started may be

comparatively small. The series-wound motor is eminently adapted for that part of the work, the starting. Plate 26A shows an electrically driven three-throw ram pump for dip workings, and Plate 24B shows a three-throw electrically driven pump arranged for sinking. But there is another feature about the ram pump. The quantity of water it delivers depends upon its speed. Each stroke of each pump delivers a certain quantity of water, and therefore the greater the number of strokes per minute, the greater the quantity of water delivered per minute. The series-wound motor can be arranged to run at varying speeds, according to the rate at which it has to deliver the water, by either shunting its field coils, or varying the pressure; but a shunt-wound motor with a variable resistance in the field coils, and with a series coil arranged to assist the shunt field coils at starting, is a preferable method. The shunt-wound motor, however, will work better if it is made larger than would be absolutely necessary. An increased torque will be obtained, and the repairs bill will be lessened. Plate 23B shows a variable speed three cylinder ram pump, driven by an electric motor.

The Bucket Pump

So far as the author is aware, the bucket pump has not yet been driven electrically, but there is no reason that it should not be, and there will be cases, where power is generated at a central station and delivered to several mines, that it will be convenient and economical to drive even the large bucket pumps that are used in some of the deep mines by electricity. In the bucket pump, as the name implies, the water is raised by one or more buckets, fitted with inlet and outlet valves. The buckets are fixed at the end of long rods, and are lowered into the water that is to be raised, the inlet valve at the bottom of the bucket opening as the bucket descends, and closing with the weight of the water above it when the bucket commences to ascend, the valve at the top of the bucket then opening, and the water being forced into a raising main in the usual way. For pumping large quantities of water, plunger and bucket pumps are sometimes used in combination, the two being attached to one set of pump rods. The bucket pump is usually worked from a beam engine, the pump rods being attached to one end of an iron beam pivoted at its centre, the other end of the beam being attached to the connecting rod of the steam cylinder. In some cases the engines driving the pumps are compound, the two cylinders working two beams, to which are attached two sets of buckets, the two working quite independently. In other cases the engines are made compound, but the two cylinders are connected to the same beam, but with different lengths of stroke, to fit



PLATE 22A.—Messrs. Siemens Bros.' Motor Switchboard for Mining Work.



PLATE 22C.—Wound Rotor of Two Phase Motor, with Rings for connecting to Starting Resistance.



PLATE 22B.—Back of Messrs. Siemens' Motor Switch shown in Plate 22A.

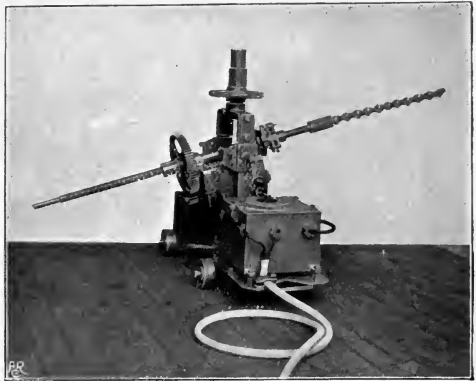

PLATE 22D.—Diamond Electric Rotary Drill.

the position at which their connecting rods meet the beam. The old beam pumping engine has been a very good servant, and a very economical one. The extreme case, that of the Cornish pumping engine, in which a very large steam cylinder was employed, and in which the steam only entered under the piston, which returned by gravity and by the pressure of the atmosphere above, the steam underneath it being condensed, held its own for economy up till within very recent years. As the beam pumping engine is always fixed close to the boilers, a range of boilers being sometimes fixed specially to supply it, it would be difficult to introduce any economy with electric driving, because every economy in steam generation that can be employed at the electricity generating station, can be employed at the pump station, and the old beam pump, working day and night, is one of the ideal constant loads. Where pumping has to be done at a distance from the generating station, it may be economical to drive the old beam pump by electric motors, in place of keeping a battery of boilers and the attendants, at the pumping station. The arrangement for effecting this is very simple. The steam cylinders would be moved, the connecting rods on the steam side would be replaced by rods sufficiently long to reach from the beam end to a crankshaft, that would be placed in any convenient position, but would preferably occupy the pit from which the steam cylinders have been removed. The crankshaft would be driven directly by connecting it mechanically to the axle of an electric motor, or it could be driven by ropes or belts, as convenient. Arrangements could be made also for varying the speed when required in the manner described.

Power required for driving Pumps

In the early days of electric driving of pumps and other apparatus, trouble sometimes arose through the motor not being sufficiently large. In other words, proper calculations had not been made. The power required in the electric motor is made up of the following quantities:—

1. The power required for lifting the quantity of water that is to be raised per minute to the height at which it is to be delivered. That is to say, the weight of the water that is to be raised per minute in pounds, multiplied by the height to which it is to be raised in feet, the horse-power being found by dividing the product of these quantities by 33,000. Pure water weighs 10 lbs. per gallon. The weight of water impregnated with salts, such as are found in nearly all pit water, is slightly higher than this; but for practical purposes, if the usual working margin is allowed after making the calculations,

10 lbs. per gallon will not be found far out. Thus, if, say, 100 gallons per minute are to be raised through 330 feet, the power required will be—

$$\frac{100 \times 10 \times 330}{33,000} = 10 \text{ H.P.}$$

2. The power required to overcome the friction of the water in the pipes through which it is forced. Water and air, when forced through pipes, ducts, etc., rub on the sides of the pipes or the ducts, and in rubbing create friction, and friction absorbs power in direct proportion to the extent of the surface rubbed, and to the square of the velocity at which the water or air is flowing, and to a constant depending upon the surface over which it rubs. Thus, the larger the pipe, and therefore the larger its surface, the greater the friction. Also, the longer the pipe, the greater the friction. From this it would appear as if a larger pipe created more friction than a small pipe; but this leaves out the question of the velocity of the water. Where a small pipe is employed, the water has to be forced through it at a higher velocity than with a larger pipe, and as the friction increases as the square of the velocity, while it only increases directly as the surface of the pipe, the gain is on the side of the larger pipe. It is usual to allow for the friction created by water passing through pipes by reckoning it as so much head that would have to be overcome, if the water were lifted vertically. The head or vertical height, equivalent to any length of any pipe, with any quantity of water passing through it at any velocity, is found by taking the equivalent column that would force the water through the length of pipe of the given size at the velocity named. Engineering pocket-books give the equivalent heads for different velocities of water, and for different sizes of pipe. Thus, for 50 gallons of water per minute passing through 100 feet of clean, straight pipe of 2-inch bore, the loss of head is 10·4 feet, while with a 3-inch pipe it is only 1·19 feet. The loss of head due to the friction of 2000 gallons per minute through 100 feet of the same pipe, of 8-inch bore, is 12·3 feet. From any of the tables mentioned, the loss of head can be obtained for any given quantity of water per minute passing through any given length of pipe of any given size; and, conversely, the size of pipe that will allow of the passage of the water with only a given loss of head may be determined. Having obtained the loss of head, the formula given above is again employed, and the power required is measured by the product of the number of gallons per minute multiplied by 10, multiplied by the loss of head in feet, and divided by 33,000.

In estimating the loss due to friction, however, it should not be forgotten that pit water usually contains salts in solution, which are deposited upon the inside of the pipe, gradually lessening the bore,

increasing the velocity of the water if the same quantity is to be pumped, and increasing the loss of head and the power absorbed. It will be wise, therefore, when arranging for an electric motor to drive a pump delivering water, as is so frequently necessary in mines, through a long line of pipe, to allow for a loss of head in a size of pipe a certain percentage less than that which is actually fixed. The motor will possibly work a little less efficiently, but the loss in coal at the generating station will be more than made up by the lessened repairs bill, and by not having the inconvenience of the pump breaking down periodically, when large quantities of water have to be dealt with, and of having to fix a larger motor after a certain period.

Having obtained the power required for (1) and (2), the efficiency of the pump must next be taken into consideration. As explained, the efficiency of the modern centrifugal pump is claimed to be 70 per cent., and in some forms made by the Worthington Co. it is claimed to be as high as 86 per cent. The efficiency of the slow-moving ram pump is not higher than $66\frac{2}{3}$ per cent., but that of the modern "Express" pump, running at the higher speeds mentioned, is claimed to be as high at 90 per cent. The efficiency of the gearing, whatever it may be, has also to be taken into account, and then the efficiency of the motor itself, and the three efficiencies may be multiplied together. Thus, if we take the efficiency of the pump at 70 per cent., that of the gearing at 95 per cent., and that of the motor at 85 per cent., multiplying the three together will give us 56.5, and we obtain the total power that must be delivered to the electric motor by multiplying the sum of the powers required by $\frac{100}{56.5}$. Thus, if

the power required for the lift of the water through the vertical height is 10 H.P., and the power absorbed by the friction of the pipes is 5 H.P., making a total of 15 H.P., the power delivered at the terminals of the motor, with the above efficiencies, must be 26.5 H.P. It is also well to remember another point. In the above calculation the efficiency of the motor was taken as 85 per cent., which will be correct for any well-made modern electric motor when it is new. But if the pumping plant is to be of any service, it will probably have to work for a number of years, and the efficiency of all parts will decline. The gearing will probably wear; the pump valves, where there are any, will wear, and will allow slip of the water past them; the efficiency of the electric motor will also decrease from various causes, particularly if it is of the continuous current type, and its commutator has to be renewed. It is therefore wise to consider the efficiencies as rather lower than those given above, or, in other words, to allow a larger motor. This is a wise rule to adopt in every case where motors are employed in mining work. It

means probably a little extra current when the motor is first run, but it means continuous running, which is of far more importance, and which saves the additional coal many times over. It will be understood that the power mentioned, the 26·5 H.P. or more that is to be delivered to the motor, is the electrical energy actually present in the motor, when it is working, as measured by the current passing through it, multiplied by the pressure across its terminals. Thus, for 26·5 H.P., if the pressure at the terminals of the motor when it is running and furnishing its 26·5 H.P. is 500 volts, the current it will be absorbing will be 39·7 ampères, and that is the current that must be provided for the motor when performing its full work.

Haulage

The next use of electricity in mines was for haulage. There are three forms of haulage, to all of which electric driving has been applied—endless rope, main and tail, and single drum. The endless rope problem is by far the simplest. The haulage system consists of a single rope coiled round a friction pulley at the driving station,

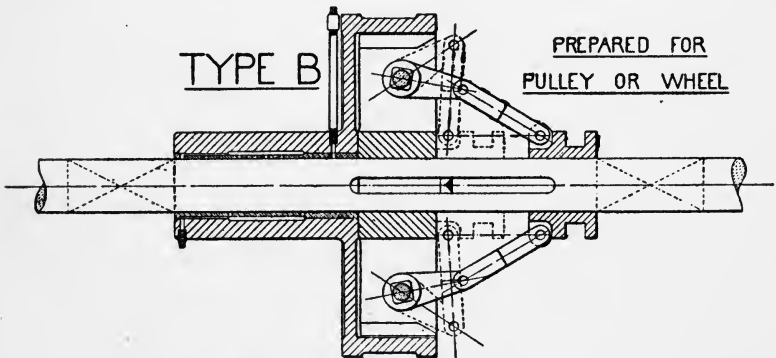

FIG. 135.—Section of David Bridge's Friction Clutch.

carried forwards on pulleys between one pair of rails to the end of the road, round a tightening pulley at that end, and back over rollers to the driving station. One half of the rope is travelling towards the driving station, and to this half the full trams are attached by clips, chains, and other devices. The other half is travelling towards the coal face, and to this the empty trams arriving from the surface are also hitched. There is practically, when the mine is working normally, a uniform load upon the driving shaft of the friction pulley, and all

that is required from any form of motor is rotary motion communicated

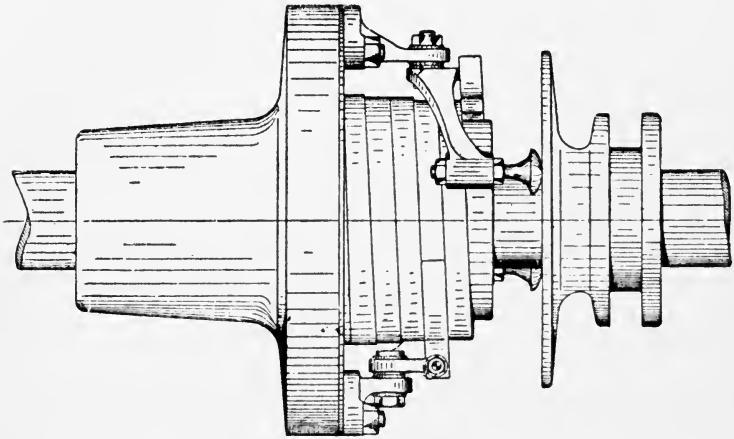

FIG. 136.—Coil Clutch.

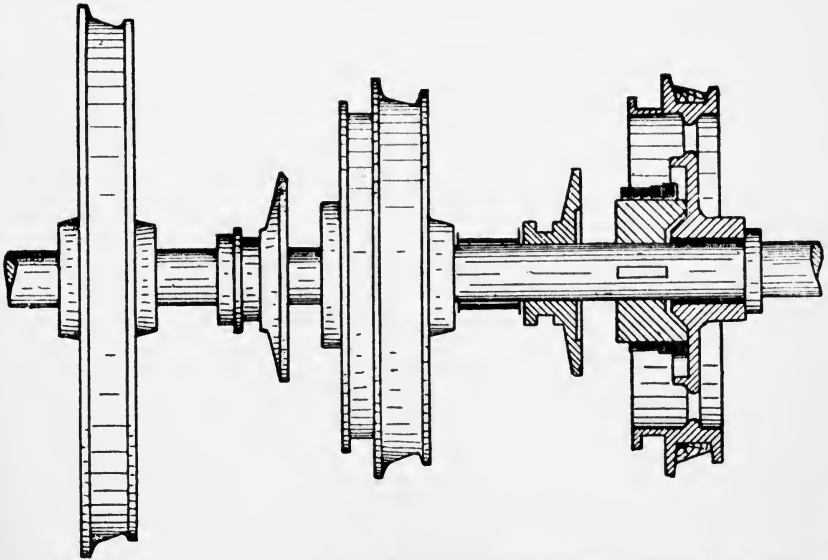

FIG. 137.—Friction Clutches for two or more Sets of Endless Rope Haulage driven from the same Shaft.

to the driving shaft. In large collieries there are often several endless ropes running out to different districts of the mine from one driving

shaft, and the friction pulley belonging to each rope is provided with a friction clutch, which connects it to the driving shaft, and disconnects it at will. Shunt-wound continuous and three-phase motors are the most suitable for this class of work, but the same difficulty arises about reducing the speed. This, however, has been easily overcome by the interposition of second motion shafts, between the shaft of the motor and the driving shaft of the haulage. The question of starting against a heavy load does not often arise here, as the whole of the haulage ropes can be disconnected when starting up by means of their friction clutches. Figs. 135 and 136 show forms of friction clutches, and Fig. 137 the arrangement of two or more on one shaft. Plate 27A shows an electrically driven endless haulage plant.

Power required for Endless Rope Haulage

Where electric driving is being introduced to take the place of driving by steam, compressed air, or ropes, the simplest method of finding the power required is to indicate the engines that are doing the work by the method that is being displaced. But where the haulage is being laid down new, or where there is no opportunity of obtaining an accurate measurement of the power being taken, the calculation is a very simple one to find out what power the motor should be capable of exerting. The author would again warn those who have matters of the kind in hand, against the common failing of allowing too little power. It is too often supposed, when electricity comes on the ground, that it will do the work with a less expenditure of energy than other power. Where electricity has the advantage in mining work is in the smaller losses in transmitting the energy. Steam, for instance, which is now almost obsolete, but which was employed very largely thirty years ago for transmitting power in mines, is subject to very heavy losses from condensation in the steam pipes. A large portion of the steam which should perform work in the engine driving the haulage or other apparatus is converted into water on its way to the engine it is to drive, and is then not only useless for driving, but is often a danger to the cylinders of the engines, and to portions of the steam pipes. Compressed air is also subject to very heavy losses, principally owing to the leakage of the air which takes place, from the pipes which are transmitting it to the engines it is to work. As mining engineers know, to their cost, the floors of a mine are constantly working, constantly changing their form, and bringing excessive strains upon the joints of pipes which lie on the floors, with the result that leaks are frequent, and the air delivered to the engine in-by is very much less than that which was compressed for the purpose on the surface. To calculate

the power required for an endless rope haulage system, it is first necessary to find the total weight of the largest number of trams which are on the road at any instant. As was explained, there should be the same number of empty trams as full trams on the two sections of the rope at any moment, so that the total weight upon the rope is found by taking the total number of trams, or twice the number of either full or empty trams, and adding to it the total weight of coal carried by the trams, or the weight of coal carried by any individual tram, multiplied by the number of full trams on the road. Thus, if there be twenty empty trams and twenty full trams upon the road, and each full tram carries one ton of coal, while each tram itself weighs, say, half a ton, the total weight upon the rope is $40 \times \frac{1}{2}$ ton = 20 tons + 20×1 ton = also 20 tons, or a total of 40 tons. The work required to be performed in transporting the 20 tons of coal and the 40 trams is the work employed in overcoming the friction of the tram wheels against the rails and the tram axles themselves in their bearings, or, where the wheels are loose, the axles in the hubs of the tram wheels. The frictional charge, as it is called, has been measured for a number of trams working under different conditions, and by the latest determination it has been found to be from 32 to 80 lbs. per ton, according to the condition of the road, the trams, etc. That is to say, when a tram or a number of trams weighing the 40 tons mentioned above are being transported along the line of rails in a mine, the work required to transport them on a level road may be as much as 40×80 lbs. = 3200 lbs. The work involved in transportation is measured by this frictional charge, 3200 lbs., multiplied by the rate at which the load is being moved, the number of feet it is moved over per minute, the work performed in transporting when measured in this way, being equivalent to the work that would have to be performed in lifting the same number of pounds the same number of feet vertically as it is transported over in a minute on the level. Endless rope haulage runs at from $1\frac{1}{2}$ to 3 miles per hour, 2 miles an hour being a fairly average rate, and this is equivalent to 176 feet per minute. So that the work required to be performed in transporting the 40 tons of mineral and waggons at the rate of 2 miles an hour will be measured by—

$$\frac{3200 \times 176}{33,000} = 17.67 \text{ H.P.}$$

In addition to this, if the road inclines at all, either against the load or with the load, the circumstance must be taken into account in the calculation. Thus, suppose that the road dips gradually 1 in 40 towards the face. This means that the full trams have to be lifted the vertical height corresponding to that gradient in their passage

from their hooking-on places to the driving engine. On the other hand, the empty trams have the benefit of the falling gradient, and it may be taken that the weight of the empty trams descending balances the weight of the full trams, but without the coal, ascending so that the lifting of the weight of coal through the vertical height has only to be provided for. The question arises here also as to the average height through which the coal has to be lifted. The filled trams are hooked on at various points along the road, where branch roads, or, as they are called, secondary haulage roads lead to the face of the coal. If we assume the total length of the haulage road to be one mile, and that the trams commence to hook on at half a mile, so that those from the nearest station have to be transported through half a mile to the hauling engine, and through the vertical height due to half a mile, while the tram at the farthest hooking-on place has to be transported a mile and lifted through the vertical height corresponding to a mile, we shall not be far wrong if we take three-quarters of a mile as the distance and the height due to that as the vertical lift. In addition to the above there is the power required for moving the rope itself, which varies, of course, according to the weight of the rope, the number of rollers, sheaves, etc., it travels over, and the rate at which it travels.

Having obtained the power required to overcome the friction of the mine wagons, that required for the vertical lift, if any, and that required for moving the rope, we have in the sum of these the total power that must be delivered to the rope itself. To this quantity must be added the power absorbed by the friction pulleys, axles, etc., this total making the power that must be delivered to the driving axle of the friction pulleys. As in the case of pump driving, we have then to add the power absorbed by the second motion shaft, where one is employed, as is most usual, and by the motor itself. Taking, as before, the efficiency of the gearing as 95 per cent., and that of the motor as 90 per cent., the combined efficiency of the two will be $85\frac{1}{2}$, and the total power arrived at, as described above, must be multiplied by $\frac{100}{85\frac{1}{2}}$. The author would give the same caution in

this case as in the case of pump driving, and would strongly advise that in the calculations the efficiency of the motor and the gearing should not be taken at their best, because, as in other cases, the efficiency decrease with time and wear, and it will be safer if the motor is taken at 80 per cent. and the gearing at 90 per cent., the combined efficiency being taken at 72 per cent.

The number of trams that will be upon the road when the rope is fully loaded will be found by taking the output that is required from the particular district, and the quantity of coal carried by each tram.

The single drum or dip haulage motor also presents a simple

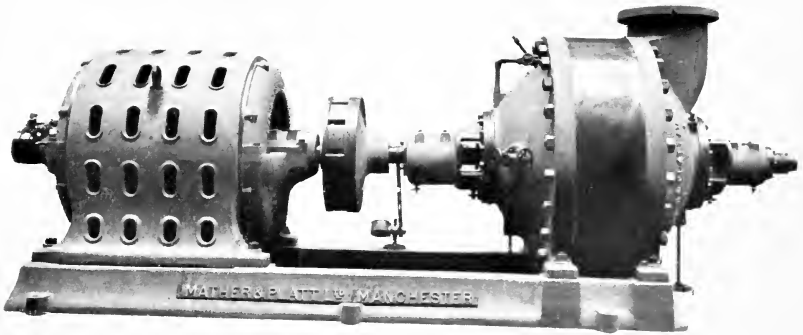

PLATE 23A.—Single Chamber, High Lift Centrifugal Pump, driven by Electric Motor. Messrs. Mather & Platt.



PLATE 23B.—Mather & Platt's Variable Stroke Three Throw Ram Pump, driven by an Electric Motor. The three Cylinders are arranged round the Containing Cylinder, and the Stroke is regulated by the Lever on the Right.

[To face p. 304.]

problem. It consists usually of a drum with a rope coiled on it, the rope being driven by any convenient source of power. The rope is usually carried down a dip to the face, where it is attached to a full tram, which is hauled up to the top of the dip or "brow" by winding the rope up on the drum. Series, shunt-wound, and three-phase motors are applicable to this work, but, preferably, the shunt-wound motor, with a series coil added to give starting torque. It is sometimes arranged for one end of the rope to lower one or more tubs down, while the other end is hauling one or more up, the motor, if one is employed, having only to furnish the difference between the energy given out by the descending tubs and that taken by the ascending tubs.

Power required for Single Drum Haulage

Single drum haulage plants may be used for short "staple" pits, from one seam to another within the mine, also for winze hoists in metalliferous mines, and for hauling single or a small number of trams up dip roads, leading from the face to the main haulage road. The calculation for the two is not quite the same. For the simple hoist or wind the power required is measured by the weight of the cage and its load, or the skip and its load, plus the weight of the hoisting rope, multiplied into the vertical height lifted. This is the total power required in foot-pounds, and the horse-power required is found by taking the lift in feet in one minute, multiplying it into the total weight, as described above, and dividing by 33,000; or, where the time is very short, taking the total lift in one second, multiplying by the weight, and dividing by 550. This gives the horse-power that must be delivered to the rope that is to raise the cage or skip with its load.

To this power must be added the power absorbed in friction by the drum upon which the winding rope is wound up, that absorbed by the gearing, if any, and that absorbed by the motor. Or taking again the efficiency of the motor as 90 per cent., and the combined efficiency of the gearing and drum as 80 per cent., the power to be delivered to the rope must be multiplied by $\frac{100}{72}$. Where the single drum is employed to pull up an incline, the power required is made up of two quantities—that required to raise the load, consisting of the tram and its load of mineral through the vertical height, and that required to overcome the friction of the tram wheels upon the rails and upon their axles. These are found in the same way as described with endless haulage, and the total power is equated with the efficiencies of the haulage drum and the motor—say a combined efficiency of 72 per cent., as described above. Plate 27B shows an electrically driven single drum haulage plant.

Main and Tail Haulage

The main and tail haulage is the most difficult of all to deal with. With this arrangement there is practically an endless rope, but it consists of two ropes, called respectively the main and the tail rope. The main rope is attached to the front of a journey of trams, the tail rope being attached to the rear tram, the trams completing the loop. The trams, as they are filled, are hauled to a certain point, to which the main and tail ropes are also brought. They are pulled out to the haulage station by winding the main rope on its drum. The tail rope at the same time being run out off its drum, it being taken round a pulley in the same position as the tightening pulley of the endless haulage, and attached to the rear tram. When the full trams have been pulled out to the haulage station, and passed on to the pit bottom or to the main haulage, as is frequently arranged, a journey of empty trams is made up which complete the loop between the main and tail ropes, and they are pulled out to the station from which the full trams were brought by winding up the tail rope on its drum, and allowing the main rope to run out behind the trams. The problem is more difficult than the endless rope problem, because the motor has to start against the full load, and because the haulage roads are nearly always very irregular. During one portion of the run out the load may be running up an incline, and during another portion it may be running down an incline, while during a third it may be on the level.

Further, as the load approaches the haulage station, the speed has to be lessened gradually, and the journey brought quietly to rest, in such a manner that the horses, which are often employed to draw it to the pit bottom, or to the main haulage, can easily handle it. The shunt-wound motor and the three-phase motor are again the most suitable, the shunt-wound motor having a series coil added for starting torque, and its speed being controlled by varying the current in the field circuit. The speed of the three-phase motor is controlled by inserting resistance in the rotor circuit, which is brought into operation only when speed is to be lessened, and when the journey is to be brought to rest. At the recent Colliery Exhibition, the Lahmeyer Co. showed what, in the author's view, was a very well worked out arrangement. The three-phase rotor was wound for only two phases, the stator being wound for three. Resistances of sufficient size were arranged to be thrown into the rotor circuits, and the whole was controlled by a horizontal drum, controlled on the lines of the tramcar controller. The controller itself, and a reversing switch, were operated at a convenient distance by a long lever, very similar to the ordinary steam engine lever, which was

thrown forward or backward to insert or take out resistance, and to right or left, to direct the current normally or reverse, so that the attendant had the apparatus completely under control, and with a very simple arrangement. Plate 27c shows an electrically driven main and tail haulage plant.

Power required for Main and Tail Haulage

The motor required with main and tail haulage is always larger than that required with endless rope haulage, because a larger quantity of mineral has to be drawn out at one journey, and at a higher speed. While the load in the case of the endless rope haulage system is uniformly distributed throughout the rope, and the rope is always working, always receiving a load both for the pit bottom and for the face, and is always delivering coal at the pit bottom and delivering waggons at the face, with main and tail haulage the work is done more or less spasmodically. As explained, a journey of trams making up a considerable quantity of coal, is made up at intervals, and is pulled rapidly out to the pit bottom. While the endless rope also runs at only an average of two miles an hour, the main and tail ropes run usually at from six to ten miles an hour. Hence the greater economy of the endless rope system in engine power. While the actual work done is the same, the same quantity of coal being drawn over the same distance, with the endless rope a long time is taken in the transportation, and so a smaller engine or motor is able to do the work. The great advantage of the main and tail system over the endless rope is the fact that only a single road is necessary, while a double road is required with the endless rope, and this delayed the adoption of the endless rope system for a very long period. With main and tail haulage the power required is made up, as before, of two portions, that required to overcome the friction of the trams on the rails, etc., and that required to provide the vertical lift. As before, the power required to overcome the friction is obtained by taking the weight of the largest number of trams that may compose a journey, plus the weight of the largest quantity of mineral that the trams may carry, and allowing 80 lbs. per ton of this quantity, multiplying the amount so obtained by the distance travelled over in one minute, 880 feet, where the rate of transportation is ten miles an hour, and divided by 33,000. The power required for the vertical lift is found in the same way as has been described in connection with endless rope and single drum haulage, but, as was mentioned, main and tail haulage roads are often very irregular, and the power required for the vertical lift will be that required to transport the journey up the steepest rise between the

hooking-on place and the hauling engine, at the rate at which the journey is travelling. The power required to drive the rope must also be taken into consideration, as with endless rope haulage, and the total amount equated with the efficiencies of the motor gearing and drums, as already explained.

Transmitting the Power from the Electric Motor to the Haulage Gear

In the early days of mechanical haulage, steam and compressed air driven, there was only one method of transmitting the power from the crankshaft of the engine to the shaft of the haulage plant, viz. by means of spur gearing. Spur gearing has the advantage that it is very good natured, it will go on working, provided that the power is delivered to it, when other gearing would refuse, but it is apt, in most mines, to be a great waster of power. In coal mines in particular, coal-dust gets in between the wheels and creates considerable friction, and the same thing is apt to be met with in metalliferous mines. Where, as in some instances, short ropes have been employed to displace a portion of the gearing, there has been less chance for an increase of friction from dirt between the wheels of the gearing, because there were fewer wheels, but the rope drive has itself introduced a loss of often as much as ten per cent. The only other method is by worm gearing, and up till recently this was very inefficient. Late developments, however, combined with better knowledge of the subject, and better tools, have enabled special makers of worm gearing to produce gear which it is claimed has an efficiency as high as eighty-five per cent. and over. Though this efficiency is not as high as spur gearing when new, it will probably remain at or about its initial efficiency, with reasonable care, long after spur gearing has been reduced considerably below that figure. Apart from the question of efficiency, worm gearing is the ideal arrangement for power transmission for haulage gear. It enables the haulage motor to be fixed on an extension of the bedplate carrying the haulage drums or friction pulleys, and the worm gearing enclosed in an oil chamber to be fixed well out of the way on the same bedplate, and so as to transmit the power evenly and continuously to the shaft of the haulage gear. It must be remembered, however, that when worm gear is employed, the additional power required must be provided in the motor. And, as was explained in connection with the driving of pumps, the power the calculation shows that is required to be delivered to the motor, must be that found by taking the current passing through the motor when doing its full work, multiplied by the pressure of the service across its terminals at the same instant.

Overhead Rope Railways

The overhead rope railway is a very useful apparatus for transporting coals or rubbish across a valley, especially where either a railway or a river, or, as often happens, both run in the bottom of the valley, or in certain cases for transporting them either up or down a steep hillside, and for other conditions. There are different forms of rope railways, but they are all on certain lines. There is always a stout wire rope stretched across the valley or space to be spanned, maintained as tight as conditions will allow, and the carriage or truck carrying the coal or the rubbish is suspended under the rope by hangers depending from two substantial double-flanged wheels which run on the rope. A haulage rope, which may be endless or single, practically completes the apparatus. Where one side of the span is higher than the other, the load is allowed to descend by gravity, and is pulled up by the haulage rope, which is worked by a small engine and haulage drum at the top. Where the two stations are approximately level, there are sometimes two engines, with two haulage ropes, one at each end, one pulling the load in one direction, and the other pulling it in the opposite direction, and sometimes the rope is worked from one end and is endless, the direction of motion of the engine being reversed when the direction of transportation of the load is reversed. The haulage drum in this case may conveniently be worked by an electric motor, where there is one on the ground, and it will preferably be of the shunt-wound type, and may be geared to the haulage drum by spur or worm gearing, as convenient. The power required will be found in a similar manner to that described for ordinary haulage. There will be the vertical lift, where one station is higher than the other, and there will be the friction of the flanged wheels on the rope.

A modification of this, which was introduced some time ago by Messrs. Brothers, consists of what is practically an electric locomotive running on the stretched cable by means of the two flanged wheels, but taking current from a copper wire stretched between the stations, connection being made by means of another pulley, arranged for the purpose running on the wire.

There is also the arrangement known as the Telpher system.

Winding by Electricity

Winding is the crux of the whole problem of working mines, and particularly coal mines, by electricity. In coal mines the winding engine absorbs about fifty per cent. of the total power generated at

the colliery, so that if winding can be done economically electricity has a very good chance of success, and *vice versa*. The winding problem is itself a somewhat difficult one. The usual arrangement is, there are two cages, one of which will be at the bottom of the shaft with its load of full trams, the other at the top of the shaft with the empty trams. When the wind is started, sufficient energy must be present to move the load at the shaft bottom from rest, to lift the weight of the wire rope attached to the cage, to overcome the inertia of the winding drum and the winding engine itself, and to furnish the power required for acceleration. As the wind proceeds the weight of the ascending rope becomes less, while that of the descending rope becomes greater, and the descending cage is acquiring momentum every instant, till at a certain period of the wind the momentum of the descending cage is sufficient to perform the remainder of the work involved in raising the ascending cage to the bank. Any one who watches a steam winding engine at work, particularly if it exhausts into the atmosphere, will notice that considerable power is exerted when the wind commences, that it gradually decreases, and some sensible time before the ascending cage arrives at the bank, steam has been completely cut off from the engine. Part of this difficulty has been overcome by what is known as the "Koepe" system, in which a balance rope is employed. A wire rope is attached to the under side of both cages, the loop passing under a pulley in the sump at the bottom of the shaft. The winding is performed also by a single rope, the ends of which are attached to the upper sides of the cages, the driving being performed by a friction pulley, or similar arrangement, so that the engine has only to overcome the friction of the whole apparatus, and to raise the net load of the mineral.

The Sources of Waste in Winding

One great source of waste in connection with winding engines is condensation of steam. As explained above, steam is shut off in the great majority of winding engines several strokes before the completion of the wind, and the engine stands without steam in its cylinder while the cages are being unloaded and reloaded. Further, the raising of mineral usually only occupies from eight to ten hours of the day, while the winding engine must be ready to raise or lower men, timber, tools, horses, etc., at any time during the remainder of the twenty-four hours. During the period the engine is standing condensation goes on very rapidly.

Though a very large effort has to be exerted by the steam engine when the wind commences, that is to say, when the cage is first

lifted from the bottom, that is not the period at which the greatest expenditure of power takes place. It is after this, when the engine has taken the weight of the cage and the rope, and has commenced to draw it up the shaft, and is rapidly increasing the rate at which it is raising it. The problem is very similar to that of the locomotive on a railway, when starting from rest. Great power is required to get up speed, or, as it is termed, to provide for the acceleration, the increase of speed up to the running rate, a certain increase taking place in each instant. Thus it is during the period of the wind, after the cage is lifted and before the descending cage has acquired

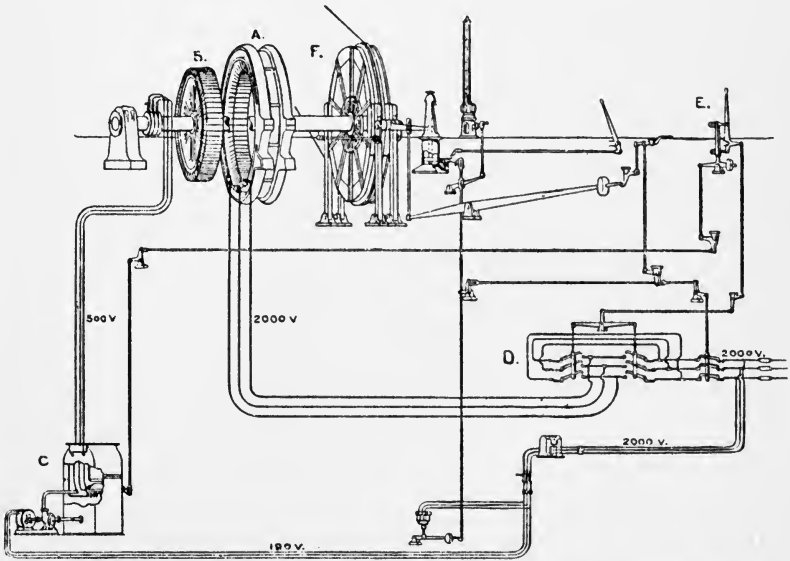

FIG. 138.—Diagram of Connections of Three-phase Electric Winding Plant at Preussen II. Colliery. *A* is the Stator, *B* is the Rotor, *C* the Liquid Controller, *D* the Reversing Switch, *E* the Controllers, and *F* the Winding Drum.

much momentum, that the great expenditure of power is required. After the descending cage has acquired sufficient momentum to perform the remainder of the wind, it is also increasing its momentum every instant, while the weight that is being lifted is also decreasing with every instant. Hence there is a surplus of power in the latter portion of the wind that is unused in steam winding, and it is the endeavour of nearly every system of electrical winding to utilize this hitherto wasted energy, to assist with the heavy expenditure of energy in the early part of the wind, and so to lessen the size of the motor employed, etc.

The earliest application of electric winding was to staple pits, the arrangement, as already explained on p. 305, being merely a modification of the single drum dip haulage, and being worked either by shunt-wound continuous current, or three-phase motors.

The shunt-wound and series-wound continuous current motors

and the three-phase motor have been also adapted in America and on the Continent for winding from the main shaft, by simply gearing the motor to the axle of the winding drum, just as with a haulage plant, the starting switch and resistance being made to be worked by a lever, similar to the lever used with steam engines. It is doubtful whether, in some cases, this arrangement is so wasteful as it seems. The complaint is made that a considerable waste of current takes place in the starting resistance, and this is quite correct; but as with ordinary motors of every kind, the starting resistance is only in circuit for a very short interval, and though it is repeated at every wind, it is easy to conceive conditions under which the loss from this cause would not be serious, and would not make up for the interest on the very heavy cost

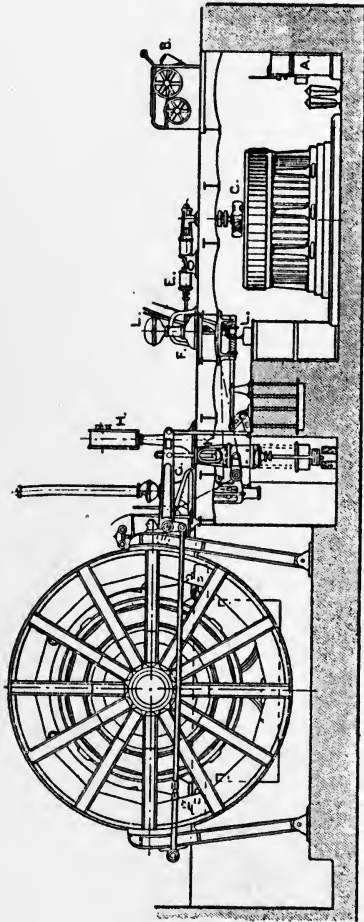

FIG. 139.—Side Elevation of Electric Winding Plant at Zollern II. Colliery. *A* is the Switchboard, *B* a Switch for changing Connections, *C* the Starting Resistance, *D* the Switch Tables, *E* the Auxiliary Starting Apparatus, *F* the Controlling Lever, *G* the Safety Apparatus, *H* and *I* Standards for Ammeter and Counter, *K* Compressed Air Brake, *L* Safety Brake and Winch, *M* Air Compressor, *N* Compressed Air Reservoir.

of more economical plant. There is also the other complaint which has been alluded to above, that the later portion of the wind, when the energy is being given out by the descending cage, is not made use of to assist the economical working of the apparatus. With very deep mines, and where very rapid winding

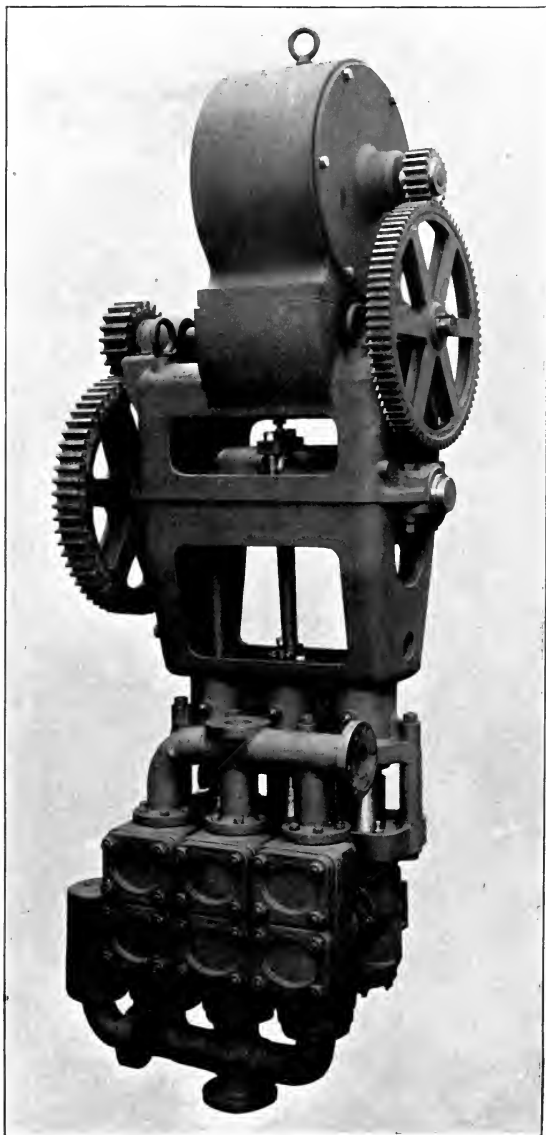
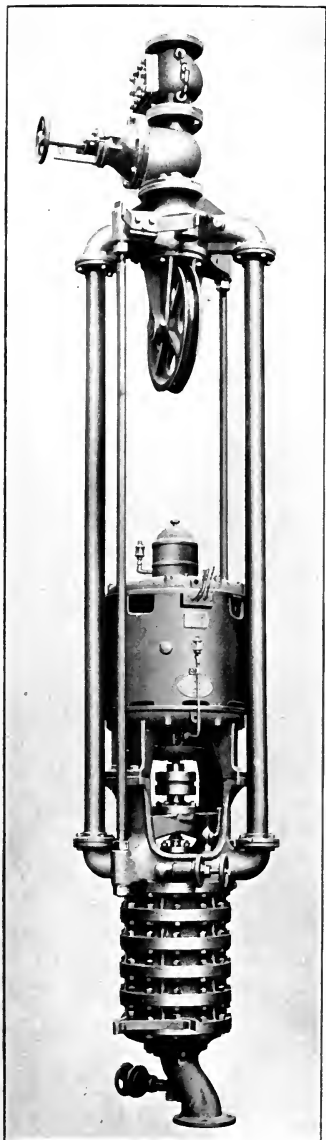

PLATE 24A.—Worthington Multiple Stage, High Lift Centrifugal Pump, driven by an Electric Motor and arranged for Sinking.

PLATE 24B.—Electrically Driven Three Throw Ram Pump, arranged for Sinking, by Messrs. Frank Pearn & Co.



is necessary, as in some of the deep mines of the United Kingdom, and in the large gold mines on the Rand and elsewhere, where a very large output is absolutely necessary to give a return for the very heavy outlay in sinking, etc., the criticism is well founded; but with shallow mines, and with mines such as some metalliferous mines, where winding is not at high speed, the loss due to the non-use of the energy liberated by the descending cage is not great. There is, however, another and a more important objection, and that is that when the wind starts, a very large current is necessary in order to provide the large starting torque, and this may have a serious effect upon the pressure of the service delivered at the mine, where the mine is receiving current from a generating station at a distance, and upon the generating station itself, if it is designed to work very close to its

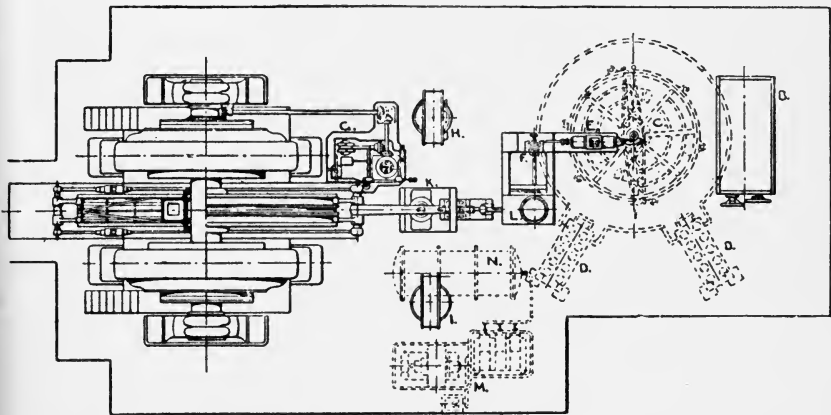

FIG. 140.—Plan of Winding Gear at Zollern II. Colliery. Letters refer to Parts as in Fig. 139.

possible output. Mr. W. C. Mountain, of Messrs. Ernest Scott & Mountain, reports that at Preussen II. Colliery in Germany, where the winding is done by three-phase motors directly connected to the winding drums, when the wind started, a drop of from 600 to 900 volts from an initial pressure of 2300 to 2400 volts took place, and that it required two engines, each of 750 H.P., and two generators, each of 550 K.W., to furnish the necessary current for winding. The pit in this case is 600 yards deep, and the winding speed was 52 feet per second when drawing coal. But again, with shallow pits and with small outputs, and with low speeds, etc., in fact anywhere but in the case of the large mines mentioned, this may not be serious. In a great many instances it would not be; and meanwhile the arrangement has the great advantage of simplicity and low cost. Plate

28A shows an electrical winding plant in a German colliery; the frontispiece, the electrical winding plant at Lens colliery in France; Fig. 138, a diagram of the winding plant at Preussen II. colliery; Figs. 139 and 140, that at Zollern II. colliery.

The Siemens-Ilgner Winding Arrangement

The Siemens-Ilgner apparatus was the first to seriously attack the electrical winding problem on economical lines, and the idea underlying both the early form of the apparatus in which accumulators were employed, and the later form in which a flywheel is used, was to absorb the energy given out by the descending cage, and to use that energy, or all of it that is available after charges for storage and conversion have been met, to assist in starting the cage from rest, and in meeting the heavy charges for acceleration at the commencement of the wind. In the Siemens-Ilgner apparatus the current from the supply station is brought to a motor generator consisting, as explained in Chapter IV., of a motor whose rotating member is mechanically connected to the armature of a generator, the motor receiving current from the supply station at whatever pressure, and in whatever form it is convenient to deliver it, a stationary transformer being employed where necessary to transform the pressure down to any convenient figure. On the axle of the motor generator is a heavy flywheel, specially constructed to run with safety at a high velocity, and it is in this flywheel that the energy liberated by the descending cage is stored, and from which it is delivered, in the well-known flywheel manner, on the next wind. A direct current motor is geared to the winding drum by spur gearing in the usual way, two motors being employed, one on each side of the winding drums in some cases. The armature of the generator of the motor generator and that of the winding motor are connected in series, so that when the motor calls for current, as explained in a previous part of this chapter, it receives it from the motor generator, which in its turn calls for it from the generating station. The pressure at which the current of the motor generator is generated is regulated by an adjustable resistance connected in the field circuit of the generator side of the motor generator, the quantity of resistance in circuit at any instant being adjusted by the engine man's lever. The working of the arrangement is as follows: When starting to wind, a certain exciting current is delivered to the generator of the motor generator, and a certain current passes from it to the motor of the winding engine, the current being sufficiently strong to provide the torque necessary to start the winding drum, rope, etc., from rest. After the cage has been lifted from the bottom, the excitation of the

motor generator is increased gradually, this providing the necessary increase of current to furnish the acceleration required to provide the increased speed of the cage. As the wind proceeds, the excitation of the motor generator is gradually lessened after the acceleration period is passed, and after the point is reached when the energy being delivered by the descending cage is sufficient to perform the wind, the excitation of the motor generator is made such that its pressure is less than that of the back pressure created by the winding motor. As the wind goes on and the descending cage drives the drum and the motor, the latter delivers current to the motor generator, driving the generator as a motor, the energy so delivered being stored in the flywheel, and the arrangement enabling the motor to be brought easily and quickly to rest on arriving at bank. When the next wind commences, in place of the heavy starting current being required from the generating station, the flywheel of the motor generator delivers up a portion of the energy it received in the latter part of the last wind, and this enables the starting current to be considerably reduced. The energy in the flywheel also assists the motor during the acceleration period, the result being that the call upon the generating station is very nearly uniform throughout the mineral winding period. In the first arrangement worked out by Messrs. Siemens and Herr Ilgner, an electrical accumulator was used in place of the flywheel, the accumulator absorbing the current delivered to it by the motor during the later period of the wind, and delivering current to the motor during the early period of the wind, very much after the same manner as the automatic reversible booster does. It was found, however, that sparking at the switches gave a great deal of trouble, as the currents were necessarily very large, and it was abandoned in favour of the flywheel. The question is one of flywheel versus accumulator, or mechanical versus electrical storage of power. There is a certain amount of danger in a heavy flywheel running at a high speed, and there is considerable difficulty in handling an accumulator under the conditions at a colliery. Fig. 141 is a diagram of the connections of the Siemens-Ilgner system, from the power station to the winding motor, and showing the method of control and the flywheel converter.

With the "Koepe" system of winding rope, the problem of electrical winding is very much simplified, and it is doubtful whether the complicated machinery of the Siemens-Ilgner is then necessary.

A modification has been developed by the Lahmeyer Co., in which also a flywheel is employed. In this arrangement there are two motors driving the winding drum, and they receive current partly from a motor generator, and partly directly from the supply service, the motor generator carrying a flywheel, as in the Siemens-Ilgner arrangement. To the motor generator is added a small

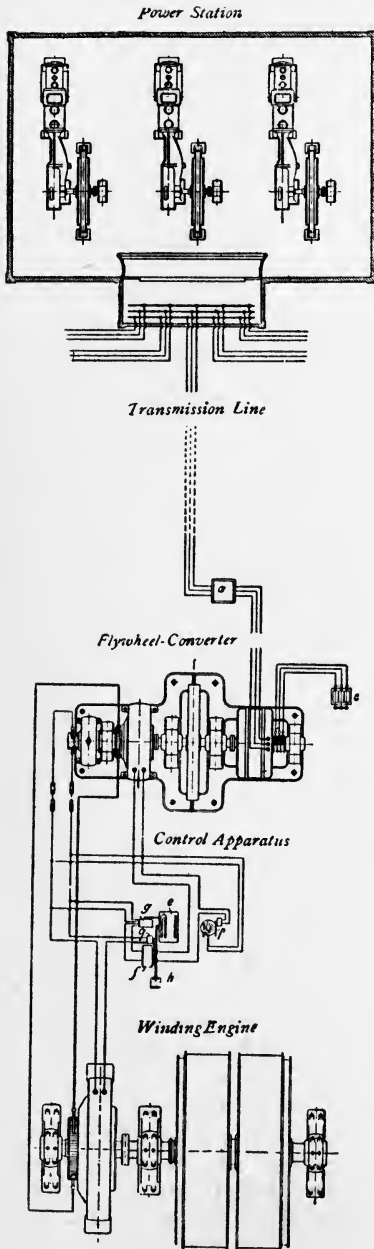

FIG. 141.—Diagram of General Arrangement of Siemens-Igner System of Electric Winding, showing the Power Station, Transmission Line, Flywheel Converter, Winding Motor and Drum, with Control Apparatus.

booster, the armatures of the three machines being on one axle, and the peculiarity of the arrangement is, the pressure developed by the generator of the motor generator is alternately increased and decreased, and reversed, so as to be added to, or subtracted from, the pressure of the supply service. When the winding motors are at rest before the wind is started, the pressure of the generator side of the motor generator is equal to and opposite to that of the supply service, so that no current passes through the winding motors. When the wind is to be started, the current in the field magnets of the motor generator is weakened, the pressure delivered by the motor generator being therefore reduced, and a current is then delivered by the supply service, this being gradually increased as the pressure of the motor generator is decreased. At a certain period of the wind the direction of excitation of the motor generator is reversed, the pressure it delivers being reversed, and therefore being added to the supply service, just as when two dynamos are connected in series, this being the actual arrangement. In this manner the pressure rises from 0 to 500, this being the pressure of the supply service, and thence to 1000 volts, this being the combined pressure

of the supply service and the reversed motor generator. When the current is to be reduced, the excitation of the motor generator is gradually again reduced, it again passes through the zero point, is again reversed, its pressure again gradually increased, till when the wind is complete, the pressure is completely cut off from the winding motors. The flywheel in this case absorbs the power given off at a certain portion of the wind, and restores it at the moment of starting. This arrangement has so far, the author believes, only been applied to mines where the Koepe balance system is employed, and in the special case under notice at the Ligny-des-Aire mines, the motor house is fixed on top of the head stocks, the drums being carried by axles supported by the head stocks, and the whole of the wind being vertical. In this arrangement also the control is entirely by the engine man's lever, varying the excitation resistance in the field coils of the motor generator, and in the booster. The variation in the pressure delivered by the generator of the motor generator is accomplished partly by varying the current in its own field coils, and partly by varying the current in the field coils of the booster.

In this arrangement, and also in the Siemens-Ilgner, it will be noticed that the current dealt with by the engine man, is only the small current passing through the shunt coils of the field magnets of the motor generator or booster, or exciting dynamo, so that there is no difficulty in constructing regulators, worked by levers very similar to those used with steam winding, which vary the resistance, without an amount of sparking that cannot be easily extinguished. Plate 20c shows the reversing apparatus employed by the International Electric Engineering Co., at the Waihi Junction Mine in New Zealand, and Plate 28B the winding motor and brake at the same mine.

Westinghouse System of Electrical Winding

The Westinghouse Co. have worked out a system of winding by electricity, in which the flywheel storage system is adopted, but in a different manner to either the Siemens-Ilgner or the Lahmeyer. The Westinghouse Co. call their arrangement the converter equalizer system, because a rotary converter is employed, not to deliver current to the winding motors, but to equalize the amount of current taken from the supply service, by storing the current that is not required when winding is not in operation, in a flywheel, the flywheel delivering the energy stored in it to the winding motors, to make up the excess demand during the periods of starting and acceleration. Where a three-phase high-pressure transmission system is employed, the three-phase currents are taken direct from the high pressure

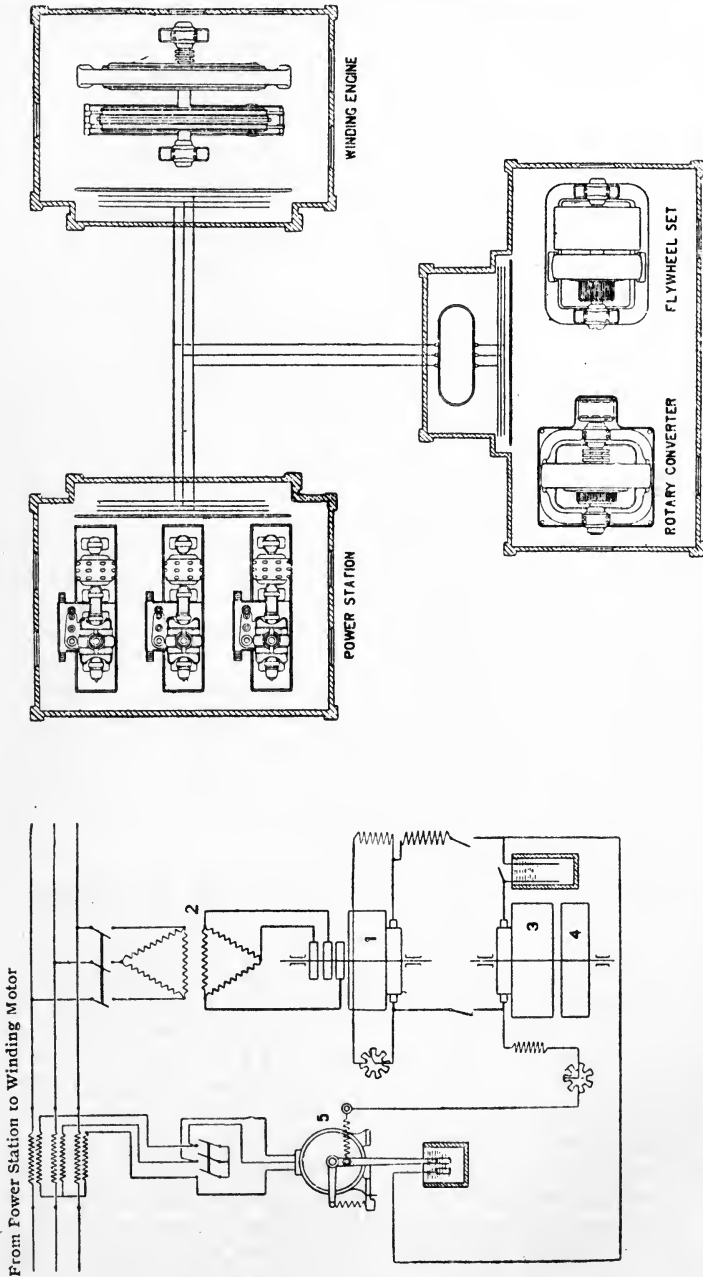

Fig. 142.—Diagrams of the Connections of the Westinghouse System of Electric Winding from a Three-phase Service with Converter Equalizer. The Diagram on the Left shows only the Connections between the Main Supply Cables, the Winding Motor, and the Flywheel Set. The Diagram on the Right shows the whole Apparatus.

system to the winding motors, transformed down if the pressure is extra high tension. Branch circuits are taken from the supply service to a rotary converter, through a stepdown transformer, and the continuous current side of the rotary converter is connected to a continuous current dynamo, having a flywheel carried on its driving axle. It is this flywheel which stores the energy, and the dynamo which acts alternately as motor storing energy and as generator delivering energy to the high-pressure three-phase motors. The arrangement is as follows. The winding drums are driven by three-phase motors directly geared to them by spur gearing. When the winding motors are not taking current, the whole of the current that would be supplied to them passes to the rotary converter, and from it after conversion, to the flywheel dynamo, which it runs as a motor, the energy it is delivering being stored in the flywheel. When the wind is started, current is delivered to the winding motors from the power service, and from the rotary converter. The flywheel dynamo, which is no longer receiving current, immediately commences to generate current when the wind commences, the flywheel giving up the energy it has stored, and driving the dynamo as a generator. The current generated by the flywheel dynamo is converted in the rotary converter to three-phase currents, and thence after transformation is delivered to the supply service, and assists the currents from the generating station in supplying the winding motors. There are a few other details that have been worked out by the Westinghouse Company. The pressure of the flywheel dynamo is controlled automatically from the supply service, by a controller acting upon its field coils. The operation of winding is controlled by the engine man by means of a lever moving over an arc, very similar to that in use with steam winding. When the winding lever is thrown forward, two operations take place, levers connected mechanically with the engine man's lever move a reversing switch by a link motion, and they also operate a liquid starting switch. The first action as the lever is moved forward, puts the reversing switch in its proper position for the wind, and it is not until the connections are made in this switch that the starting switch is put in operation. The starting switch, which consists of three electrodes in a tank to which the liquid is admitted, is then operated gradually in the usual way, and the wind and acceleration proceeds. The winding drum is provided with a pneumatic brake, controlled by another lever at the engine man's left hand, and he also has a trip emergency lever close to his foot. Further, in case of accident the emergency brake is put on automatically by an arrangement of trip levers released by a solenoid. Figs. 142, 143, and 144 show the connections and general arrangement of the apparatus.

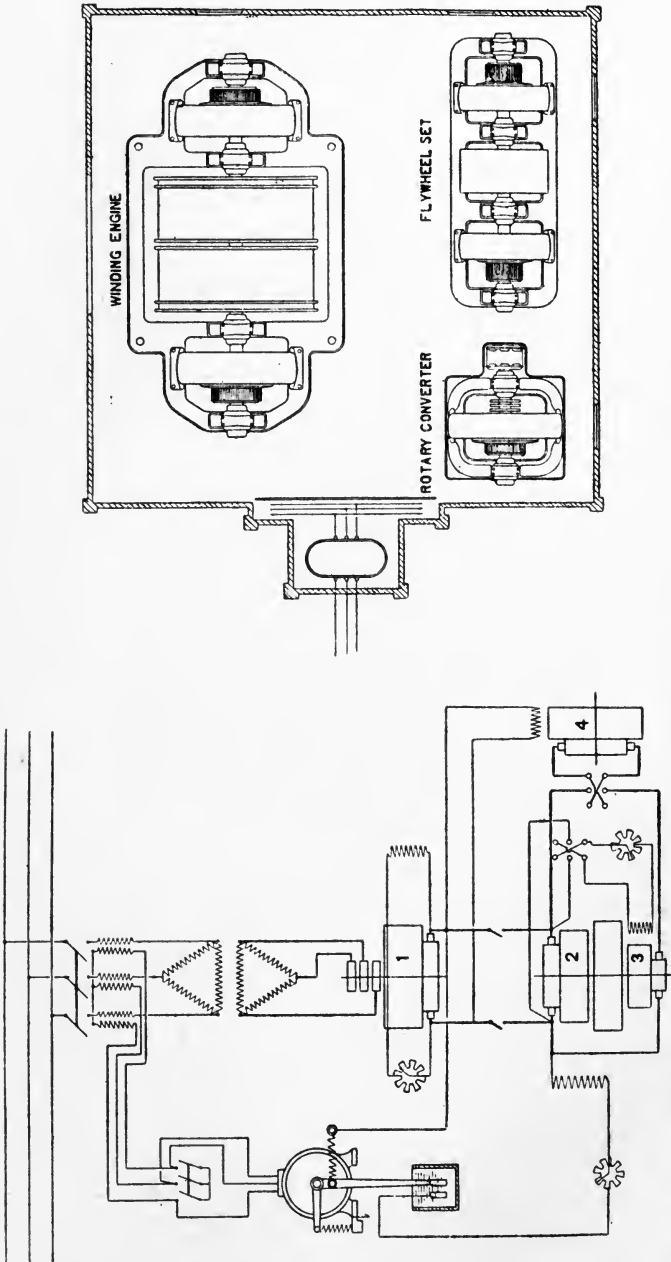

FIG. 143.—Diagram of another Arrangement of Westinghouse Electric Winding Apparatus from a Three-phase Service with Converter Equalizer. The Diagram on the Right is a Plan View of the Winding Plant.

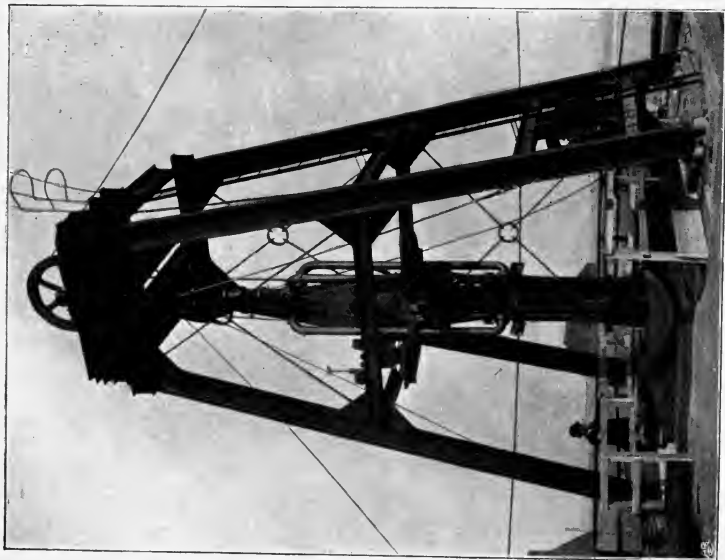

PLATE 25A.—Centrifugal, Electrically Driven Sinking Pump, ready for lowering into the Sinking. Messrs. Mather & Platt.

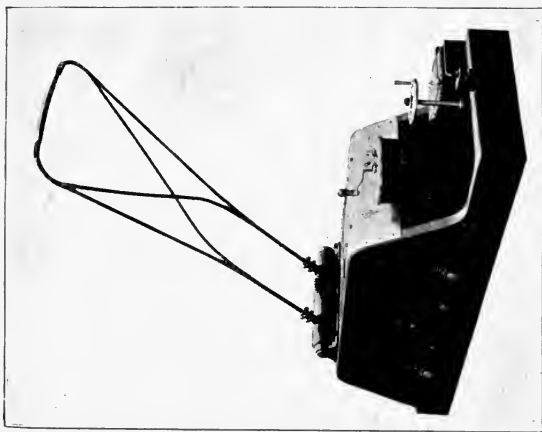

PLATE 25B.—Electric Loco for Mining Use, with Bow Trolley, as used on the Continent, made by Messrs. Dick, Kerr & Co.

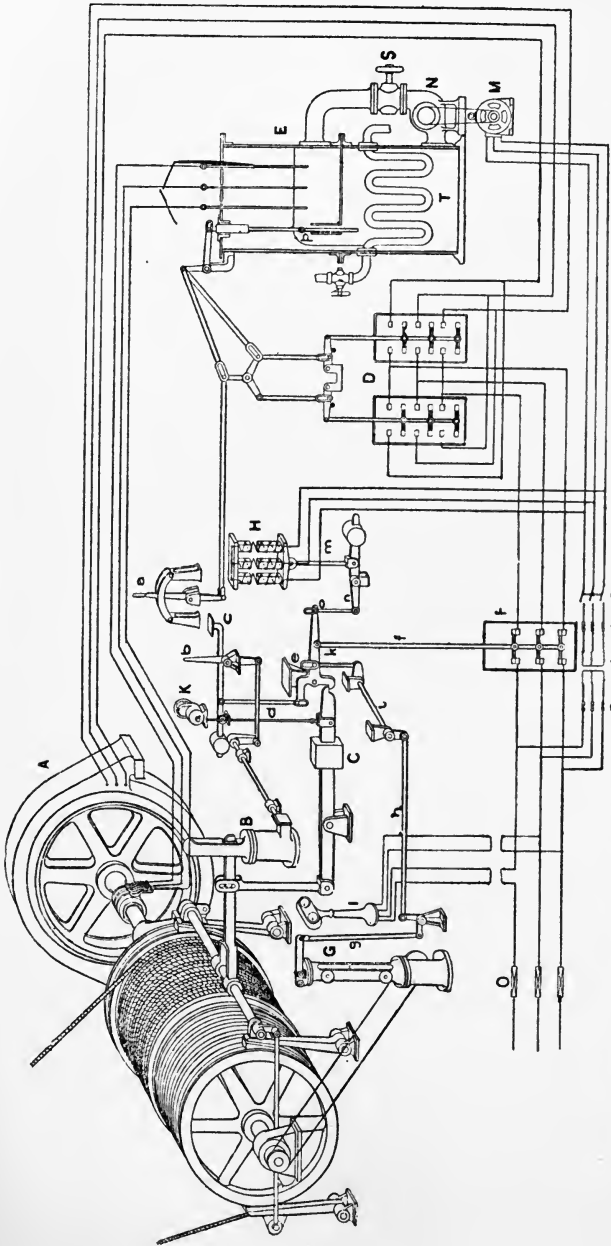

Fig. 144.—Diagram of Control Gear for Westinghouse Electric Winding Plant with Polyphase Induction Motor. *A* is the Motor, *B* the Brake, *D* the Controller, *E* the Starting Resistance, *H* the Electro Magnet releasing the Emergency Brake, *a* is the Engine-man's Lever, *b* the Brake Lever, and *c* a Foot Lever operating the Brake.

Winding in Metalliferous Mines

In the older forms of metalliferous mines, such as the older mines in Cornwall, winding was very slow, and the number of winds per hour was small. With the development of the Rand mines, however, and some other gold mines worked on similar lines, this has been changed, and winding is as rapid from modern metalliferous as from coal mines, as much as 3600 tons being brought to the surface in a shift of eleven hours and three-quarters, and as many as 92 winds being made per hour. The shafts of metalliferous mines differ from those of coal mines in several particulars. In the older mines they are not vertical, but follow the lode, and in some of the old Cornish mines often turn about in a very peculiar manner. Even in modern mines on the Rand, and other goldfields, many of the shafts are at an inclination with the vertical, and in the lode. Further, in metalliferous mines it is required to raise ore from a number of different levels, and to be able to stop the skip at any level from which ore is ready to be wound. The mine shafts are also very much deeper than the great majority of coal pits. Hence a special arrangement has been introduced for winding, which is practically an enlarged copy of the arrangement for straining the rope in endless haulage. There are two winding drums, really friction pulleys, or friction drums placed one in front of the other, driven by one pair of engines, the connecting rod of the engine driving the rear drum, and a second pair of connecting rods driving the front drums, in a similar manner to the arrangement for driving the wheels of a steam locomotive. One end of the rope is attached to one skip, is given a few turns round the front drum, then a few turns round the back drum, and then it is taken to the other compartment of the shaft, and thence to the other skip, one skip descending as the other one rises. In addition to this, to provide for stopping the skip at different levels, the rope, before it passes to the other compartment of the shaft, is taken back around a pulley similar to the tightening pulley of an endless rope, and brought forward again to the shaft. The tightening pulley is arranged to run on a pair of rails behind the engine house, fitted especially for the purpose, the tightening pulley being held at any point upon the track, according to the requirements of the wind. When it is required to wind from a shallow level, the tightening pulley is run back to the full extent of the track, that length of rope being practically wasted. When it is required for the skip to go to deeper levels, the tightening pulley is brought forward to whatever point may be required, the different points being marked on the track, and the tightening pulley being moved by an engine provided for the purpose,

the whole operation being stated to take only a few minutes. In this way it is arranged to wind from each level in turn, as may be required. The above arrangement is for steam winding, and is shown in Fig. 145, but it is perfectly applicable to electric winding, one or two motors as may be arranged, preferably two, being fixed to drive the rear drum, the forward drum being driven by parallel connecting rods, and another motor being provided for moving the tightening drum. The winding motors can be fed with current either directly from a three phase service, the motors themselves being three phase induction motors, or, as would probably be preferable, by one of the other systems that have been described, in which a flywheel and motor generator are employed. In the modern metalliferous mines also, the balance rope system is sometimes employed, a balance rope connecting the bottoms of the two skips, so that the engine

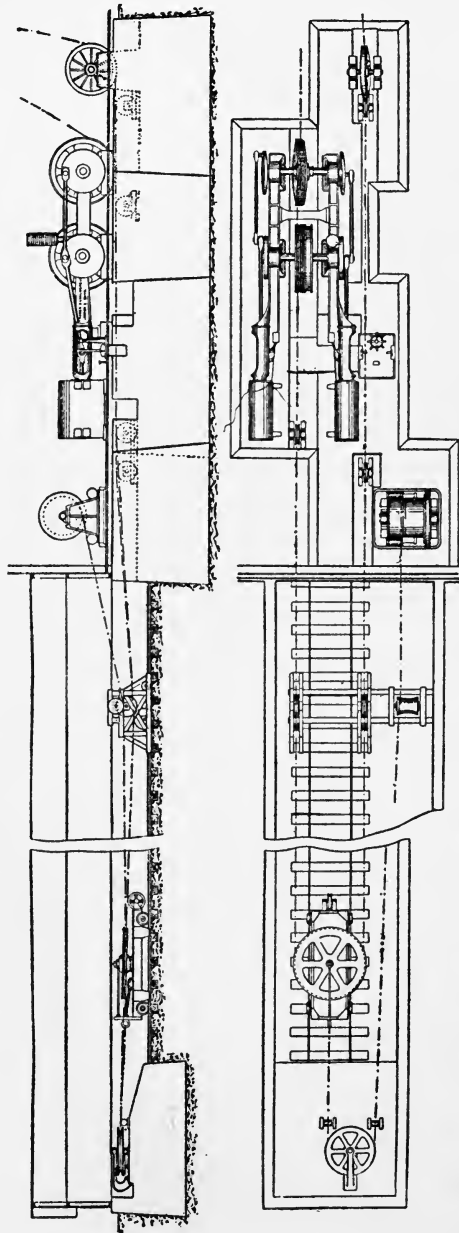

FIG. 145.—Plan showing the Whiting System of Winding from Deep Shafts of Metalliferous Mines, enabling the "Skip" to be stopped at any Level. The Rope is led back round the Pulley shown behind the Engine, and this Pulley is moved forward or backward, according to the Depth of the Level the "Skip" is to stop at.

or motor has only to overcome the friction of the rope, and to raise the vertical load, plus the friction of the skip wheels where the shaft is inclined.

In many modern metalliferous mines, the shafts are arranged vertically to strike the lode at a certain point, and from there what are practically dip haulage engines run down the incline formed by the dip of the lode. These can be worked very conveniently by electric motors, just as haulage engines in coal mines are.

There is one point, however, that is to be remembered in connection with metalliferous mines; they are nearly always very heavily watered, so that the motors employed underground should be constructed to stand water. Apparently this difficulty has been overcome, since at the Knight's Deep Mine, which was flooded during the war for two years and a half, the motors which were placed at some of the levels for driving pumps, and which were drowned and under a very heavy pressure of water during the whole period, when brought to the surface and dried, were found to be in practical working order.

Coal Cutting by Electricity

The coal-cutting machine is designed to perform the office of "holing," or "kirving," as it is called in the North, viz. cutting away a space under or over the coal, or between two seams, when there is a parting, so that it may be dislodged from its bed between the overlying and underlying strata.

The Process of Holing or Kirving

In "holing" or "kirving" by hand, the miner, lying on his side or in a crouching position, picks away a certain quantity of either the lower part of the seam, the dirt between two seams, or the dirt above a seam, according how the coal is to be got out, and he has to cut away sufficient coal, where he is holing under the coal, to allow his own shoulders and his pick to go under, and to work, the result being that he cuts away a space, the section of which is an irregular right-angled triangle, and he makes in the process a great deal of small coal, which has not such a large value as large, and which at the time when coal-cutting machines were first introduced, had only a fraction of its value. Holing by hand is necessarily more or less irregular, because different men working on the same face work at different rates. It may happen that one stall is not worked, on a long face, and this will hold back the whole of the face until the stall is brought up again. This irregularity leads to a certain

increase of the danger from the roof behind the coal face, because it is not possible to support it so carefully as when the face is straight. Broadly, there are two principal methods of getting the coal, known respectively as "longwall," and "bord and pillar," the latter method being also known sometimes as "pillar and stall," and as "stoop and room." There are other systems of working the coal, but the above are the principal, and they mark the main differences in the systems. In longwall there is a long wall or face, which may be 100 yards, or as much as 900 yards long, and there will be different faces in different districts of the mine, each face moving outwards as the coal is removed from the shaft towards the boundary of the royalty. In bord and pillar, and the other systems more or less, the coal faces are very small—from 8 feet to 20 feet. In the longwall system with hand holing, a number of men are working along the whole face, continually holing under, and continually removing the coal that is brought down, and other men are working behind them, propping the roof, and completing what are called gate roads, roads leading up to different points in the face at convenient distances apart, with the rubbish that is removed from different parts of the mine, pack walls being formed in the "goaf," as it is termed, to support the roof, which is allowed to settle down on them. In bord and pillar the whole of the seam is cut out in blocks, very much like the squares of a chess board, by roads crossing each other at right angles, and it is these roads in which the holing takes place while the mine is being opened out, the pillars that are left being afterwards removed, in what is called working back, when the roads have reached the boundary of the royalty. It will be seen that while longwall working offers facilities for machine holing, bord and pillar do not so, nor do the other methods known as "panel," etc. Machine holing has been adopted almost entirely for longwall only, it being only recently that bord and pillar working is being done by machine, though in America a modification of bord and pillar, in which large "rooms" are made from 18 feet to 20 feet, and in some cases to 60 feet wide, are also worked by some of the machines that will be explained.

Longwall Coal-cutting Machines

There are three forms of machines at present on the market for coal cutting by electricity in longwall working, known respectively as the disc, the bar, and the chain machines. The general construction of all of them is very much the same. There is a rectangular frame formed by two lengths of girder steel, or by castings joined by cross pieces at the ends, and the frame is either supported on small wheels which run on the ordinary tram rails of the colliery, these

being laid along the face for the purpose, or on skids, contrivances very similar to the runners of sleighs. The disc, the bar, and the chain carry the cutting tools, which are intended to do the work the miner hitherto performed with his pick. The disc is a wheel of from 3 feet to 7 feet in diameter, fixed horizontally, revolving upon a vertical axis, and carrying at its periphery chisel-shaped cutting tools in various ways, the endeavour of inventors being to arrange that the tools shall be easily and quickly replaced when worn, a blunt tool taking a considerably larger current than a sharp tool. It is shown in Plates 29A and 29B. The bar carries a larger number of very much smaller cutters, shaped exactly like small picks, in rows arranged around and along its surface. It is shown

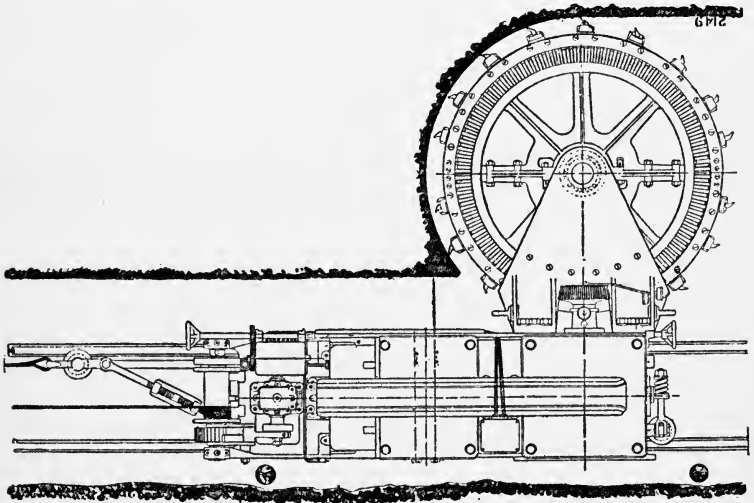

FIG. 146.—Horizontal Section showing the Action of a Disc Coal-cutting Machine.

in Plate 29c. The chain carries chisel-shaped cutters, very similar to those carried by the disc, fixed in special links forming part of an endless chain, held between two plates fixed horizontally, the chain passing round vertical rollers. It is shown in Plate 30D. With all three machines the cutting tools either chip or scrape away the clay which usually underlies the coal, or the coal itself, as may be arranged, or the dirt between two seams, etc., the motion necessary for the cutting being caused by the revolution of the disc, and the bar on their axes, and by the chain running round its rollers. Motion is imparted to the disc and the bar, and the chain, by one or two electric motors carried at one or both ends of the rectangular frame, by means of spur and bevel or worm gearing. As

explained, the disc and the chain revolve horizontally on vertical axes, the bar revolves vertically on a horizontal axis. The disc, and the chain, and the bar are arranged to cut inwards under the coal, to the depth necessary to allow the coal to fall, this varying from 3 feet to 6 feet, according to the seam, and the other methods adopted. With all three machines there is a small haulage drum fixed in the front of the machine, in the direction in which the cut is to be made, and a small galvanized iron rope is attached to this drum, its other end being secured to a prop some distance in front. The haulage drum receives motion from the second motion shaft of the gearing, and its rate of motion is arranged to be varied by different devices, according to the rate of the cutting of the coal. In all cases the rope is gradually wound up on the drum, and the machine is pulled bodily forward. As the machine moves forward,

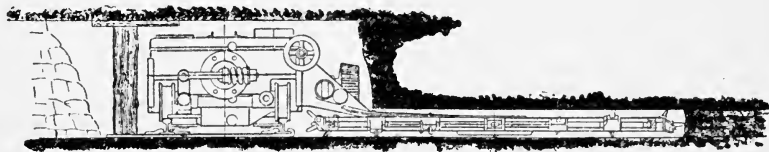

FIG. 147.—Diagram showing the Action of a Disc Coal-cutting Machine, by Messrs. Ernest Scott & Mountain.

the disc and the chain move forward under the coal, cutting the coal or dirt away in front of them as they move, and occupying a space under the coal, equal to a large portion of their own surface. The bar also cuts away the coal or the dirt as the machine is moved forward, but it only itself occupies a very small space, the bar being only a few inches in diameter as compared with the disc and the chain, which occupy several feet. The disc runs at from 20 revolutions to 70 revolutions per minute, while the bar runs from 300 revolutions to 500 revolutions per minute. The depth of the undercut is regulated by the length of the bar, the length of the chain, and the diameter of the disc, while the width of the cut is regulated by the space from top to bottom occupied by the cutters, and is usually about 4 inches. Figs. 146 and 147 show the working of disc machines.

Heading Machines

For bord and pillar working, for driving headings and so on, another form of chain machine is employed, an importation from America, in which a chain similar to that with the longwall header, and carrying cutters very similar to them, but with a very much

longer chain, is employed. The chain is carried on a long rectangular frame, supported upon a stouter frame resting on wheels or skids, similar to but larger than that of the longwall machines, and is presented with one of its small ends to the coal. The machine is shored up close to the face, the chain is set in motion around the frame, and the frame is forced outwards under or in the coal, and it cuts a groove the usual width, about 4 inches to whatever depth under may be arranged, and about 2 feet 8 inches along the face. After one 2 feet 8 inches has been cut, the frame is run back, the machine is moved over to the right or left, as may be arranged, another cut is made, connected with the first, this being followed by a third cut, and so on, till the width of the heading or the room has been cut across. In America the coal is got by a succession of rooms 18 feet, 20 feet, and sometimes as much as 60 feet wide, with pillars of coal between the rooms, and it is usual to cut across one room, and then move the machine to the next room while the coal is got down in the first, and so on.

The Rotary Heading Machine

There is one other form of coal-cutting machine known as the rotary heading machine, employed in opening out collieries, where it is required to get the coal very quickly. It consists of a bar pivoted at the middle of its length, and carrying at each end arms with cutting tools. When the machine is at work, the bar is pushed up to the face of the coal, and is rotated about its centre, the cutting tools on the arms at its end cutting into the coal, and forming an annular groove, the width of the cutting tools and with the diameter of the rotating bar. When the cutting tools have cut in as far as they will go, the bar is run back, the whole machine is moved to the rear, and the solid cylindrical core of coal, left inside the annular groove, is brought down by blasting in the usual way. The rotating bar is pivoted on an axle geared to the crankshaft of a double-cylinder compressed air engine, gearing being also provided to push the bar bodily forward as the cut proceeds, the whole being mounted on a substantial bed plate, with uprights for carrying the bearings of the crankshaft and of the axle-rotating bar, the bed plate being mounted on wheels or skids, as may be arranged. The machine has been adapted for electric driving by fixing an electric motor in place of the double-cylinder compressed air engine, and gearing the axle of the motor to the rotating axle of the bar, by spur gearing.

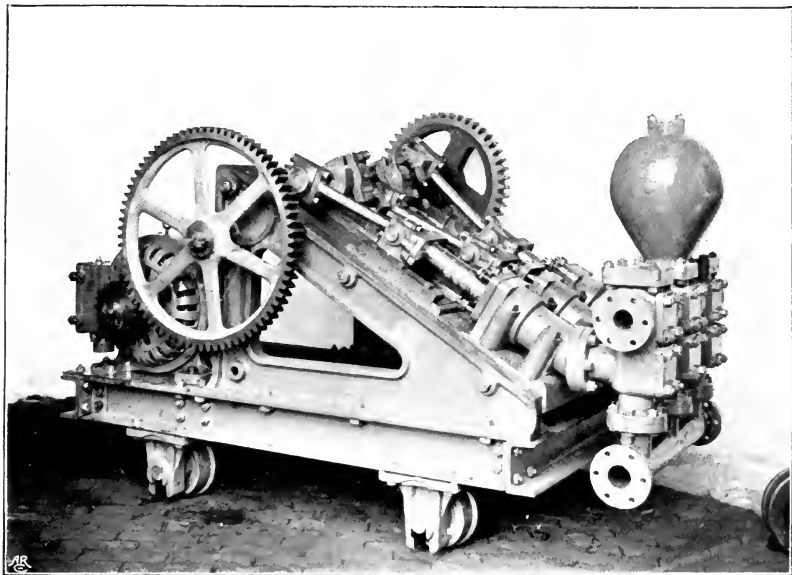

PLATE 26A.—Electrically Driven Three Throw Ram Pump, arranged for mining on the Mine Rails, made by Messrs. M. B. Wild & Co.



PLATE 26B.—Electric Mine Loco, as employed in America and on the Continent, made by the Jeffrey Co.

Motors employed with Coal-cutting Machines

So far series-wound and three-phase motors only have been employed for driving coal-cutting machines. The plan adopted in the great majority of the machines is, the motor is fixed at one end of the rectangular frame, the gearing being in the centre, and the disc, bar, or chain gearing at the other end, the small haulage drum being in the neighbourhood of the motor. In the Diamond machine, and in the Brush-Kirkup, two motors are employed, fixed one at each end of the rectangular frame, the gearing being in the middle, and the disc working also at the middle of the frame. With the bar machine and the chain "longwall" machine, gearing is provided for moving the bar and the plates between which the chain moves from a position in line with the body of the machine to the position at right angles to the machine, that it has to occupy when cutting the coal, the gearing in this case being enclosed inside dust-proof cases. In the case of the bar machine also, a reciprocating motion is given to the bar, so that the cutting tools do not cut opposite the same place at each part of the revolution. In the Peake machine, which is an improvement of the early Goolden bar machine, the bar, which is square in section, is mounted directly on the end of the axle of the armature, the gearing being thus dispensed with.

The motors provided for coal-cutting machines range from nominal 25 H.P. up to 35 H.P.; they take from 16 H.P., under the most favourable circumstances, up to as much as 50 H.P., this latter being only for a short time. Where two motors are employed, the power is, of course, divided between the two, and they are connected in series.

Delivering the Current to Coal-cutting Machines

As explained in an earlier part of the book, the supply cables are brought to switchboxes at the ends of the gate roads, and from these switchboxes flexible cables are taken to the motors. It is an important point in connecting the cables to the motors, that the connection to the motor should be made **first**, and that to the switchbox **last**. Connection in both cases should be by a simple strong form of plug, arranged to push into a socket, and the switchbox should be so constructed that it is not possible to pull out the plug unless the switch is open. If the plug is pulled out with the switch closed, sparks will pass, and in case of gas being present the consequences may be serious.

With continuous-current motors it is necessary, as in other cases, to provide a starting resistance and starting switch. The starting

resistance is made in various forms, the wire of which it is formed being covered with asbestos and protected in various ways, and the whole thing should be arranged that any sparking which takes place should be *inside* an enclosure, from which gas is excluded. The commutator of the motor should also either be totally enclosed or inside a gauze enclosure, and the attendants should be warned to keep the gauze free from coal dust, and not to open the case of the motor unless the current is switched off. With three-phase motors it is usual to employ the squirrel-cage type, as this avoids the necessity of any starting resistance, but there is a difficulty with this type in making the machine cut its way into the coal. The difficulty, however, is not a very serious one, as the machine often has a run along the face of several hundred yards, and it is only required to make a place for it at starting. There is also the difficulty with the disc machine when run by a three-phase motor, if the coal settles down upon the disc, in obtaining power to free it. Mr. Roslyn Holiday, who has done a good deal in this matter, states that he is able to get over both difficulties by switching the current on and off several times, a certain torque being obtained each time the current is switched on, and the coal being gradually cut into, or the disc being gradually freed. The three-phase motor has the advantage that the switch, which of course must be triple-pole, can be completely enclosed in a gas-tight chamber, the rods working it passing through gas-tight glands.

Drilling by Electricity

Drilling is carried on very extensively in all mining work, for the purpose of providing holes in which charges of powder, or dynamite or other explosives are placed, to bring the mineral down. In coal mining, in the great majority of cases, after a space has been provided for the coal to fall by undercutting, as explained in connection with coal-cutting machines, some force is necessary to break the coal away from the strata overlying it, or, where the cut has been made above, to separate it from the underlying strata, and this force is provided by blasting. Attempts have been made from time to time to do away with blasting. Mr. W. E. Garforth, at Messrs. Pearson & Knowles's collieries at Normanton, has succeeded in doing away with blasting, by undercutting just to the level of the cleat of the coal.

The coal seam in this case being thick (4 feet 6 inches), an undercut of 6 feet provides sufficient weight to break the coal away at the cleat, without any other force. Lime cartridges and hydraulic cartridges have also been introduced, the operation in each case being the expansion of the cartridge in the hole provided for it, the force exerted by the expanding material breaking the coal down. But both of

them require that holes shall be drilled, and in the great majority of coal mines and in all metalliferous mines blasting is still in use. The hole drilled is several feet in length, and from $1\frac{1}{2}$ to 2 inches in

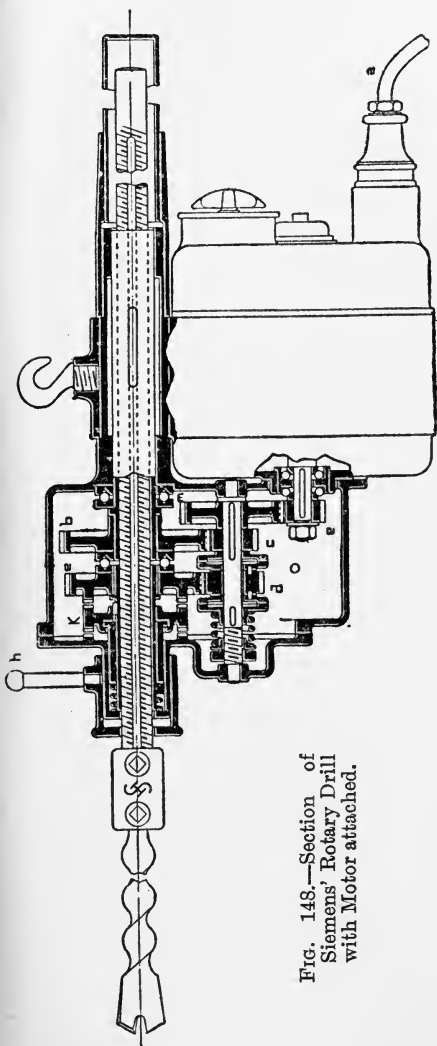

FIG. 148.—Section of Siemens' Rotary Drill with Motor attached.

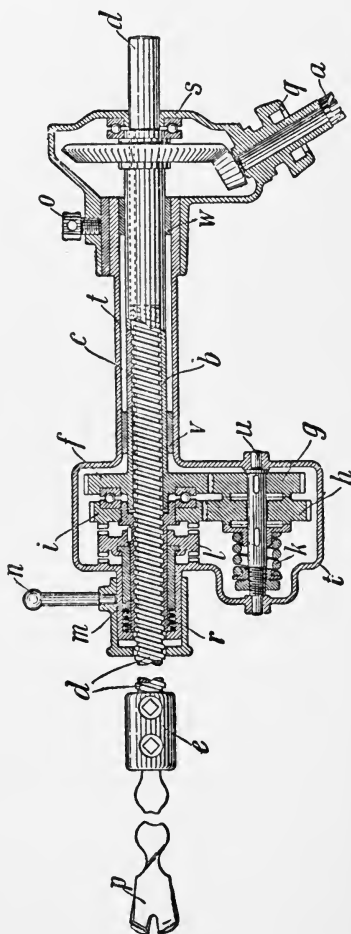

FIG. 149.—Section of Siemens' Rotary Drill to be driven by Flexible Shaft from a Motor on the Ground. *a* is the Flexible Shaft, *b* the Screw giving Motion to the Drill, *d* the Drill Shaft, etc.

diameter, and the number of holes and their depth will depend upon the nature of the mineral, the cohesive force holding it to the other strata, the thickness of the seam, and so on.

There are two forms of drilling machines—the rotary and the percussion drill. The rotary drill is applicable to comparatively soft material, the percussive drill being employed for hard rock. The rotary drill is easily driven by an electric motor, as shown in Figs. 148 and 149, and Plate 22D, all that is necessary being the provision of a motor of about 2 H.P. geared to the drill, the whole being held on a tripod or telescopic arrangement, as may be arranged.

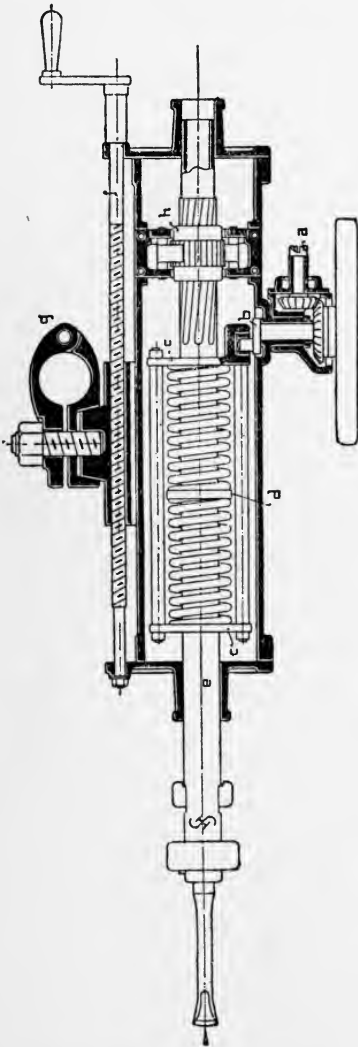

FIG. 150.—Section of Siemens' Percussion Drill arranged to be driven by a Flexible Shaft from a Motor on the Ground.

Driving the percussion drill, however, is by no means such an easy matter. The favourite method adopted by Messrs. Siemens and others is, an electric motor, which can be either carried by the drill carriage, or in a box lying on the floor of the mine, the power being then conveyed to the drill by a flexible shaft, compressed springs placed in the rear of the drill carriage, the drill carriage being released when the springs have been compressed to a certain pressure, and the drill being thrown forward by the force of the expanding springs. The Siemens drill is shown in Fig. 150. The case containing the motor, for standing on the floor and driving by flexible shaft, is shown in Fig. 151 for continuous current, and in Fig. 152 for three phase. There are springs also in front of the carriage which force the drill back after the blow has been struck, and there is the usual rifling arrangement, which comes into operation as the drill returns, by which rotation is caused. In

another form of drill made by the Denver Engineering Co., Colorado, known as the box drill, air is compressed inside a cylinder forming the drill carriage, the drill being held in front, and working

in guides as usual, and the compression of the air being accomplished by an electric motor attached to the back of the drill. The construction of the drill is shown in Figs. 153 and 154. The compressed air in this drill takes the place of the springs in the other forms described. In the Marvin electric percussion drill, made by the Sandicroft Foundry Co., another principle is introduced. Motion is communicated to the drill by means of

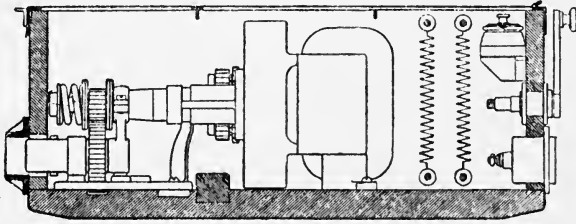

FIG 151.—Motor Case for Continuous-current Motor to be used with Siemens' Electric Drills.

a solid steel plunger, round which two coils of wire are fixed, electric currents passing through the coils. The plunger is pulled back by the current passing in one coil, and in receding it compresses a strong spiral spring in the rear. It is forced forward by the current in the other coil, aided by the force of the expanding spiral spring. This arrangement is a modification of an

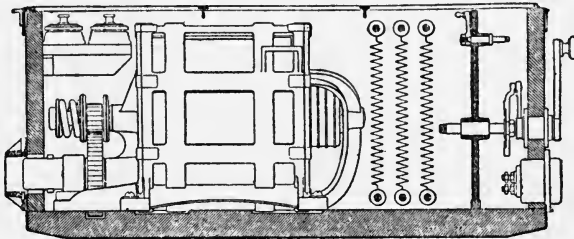
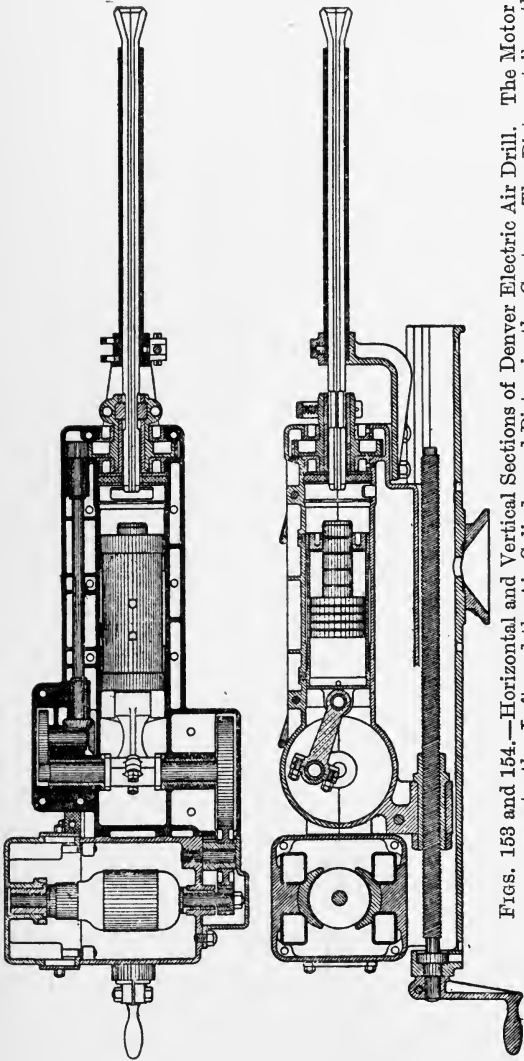

FIG. 152.—Three-phase Motor Case to be used with Siemens' Electric Drills.

earlier form of the same drill, in which alternating currents were employed, and in which it was found that the plunger heated very considerably. In the Marvin Sandicroft drill a pulsating current is employed, furnished by a special generator. The generator is a continuous-current machine, separately excited from the lighting service or any convenient supply, and arranged, by means of a special commutator, in place of the usual segmental



FIGS. 153 and 154.—Horizontal and Vertical Sections of Denver Electric Air Drill. The Motor is seen to the Left, and the Air Cylinder and Piston in the Centre. The Piston strikes the Inner End of the Drill at each forward Stroke.

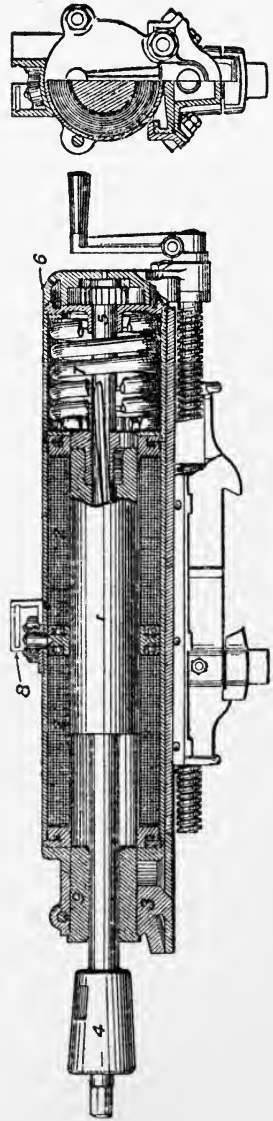

FIG. 155.—Sections of Marvin Sandicroft Electric Drill.

SWAIN 56.

commutator, to furnish a pulsating current, which is delivered successively to the different coils of the drill. The coils and the drill

are insulated with mica only. There is the usual rifle arrangement for rotating the drill. The Sandicroft Marvin electric percussion drill is shown in Fig. 155.

With percussion drills the depth of hole required is obtained by successive lengths of drill. A short drill is first inserted, and allowed to drill to its full extent. It is then withdrawn, and a longer drill inserted, and so on.

Coal Cutting by means of Drilling Machines

There is a field for the electric percussion drill as an aid to coal-cutting machines. As explained, in connection with coal cutting, in bord and pillar and other work, it is difficult to economically employ either the bar, the disc, or the chain machine, except under the conditions ruling in America, where the chain heading machine is employed in large "rooms." In addition, in narrow work, as mining men term it, where narrow roads or headings are being cut, holing under the coal is not sufficient to bring it down unless a considerable amount of blasting is employed, and it is the practice to "nick" the coal, as it is termed, on one side, and sometimes on both, the "nick" being a vertical cut sufficient to free the coal on that side. The chain heading machine, described on page 327, has been adapted in America also as a "nicking" machine, a band saw being fixed on the side of the machine, worked by the electric motor and arranged to cut a vertical "nick," as described. But this arrangement is not suitable for narrow work, and it absorbs a good deal of time in fitting up the "nicking" tool, while the tool itself is something more to be carried about. During recent years, the compressed air percussion drill has been adapted for the work under the name of the "Champion." In this apparatus a percussion drill is carried by means of a universal joint upon a vertical telescopic support, arranged to be fixed quickly in any coal face, heading, etc., and the drill is employed, instead of drilling a hole, to sweep out an arc, the radius of which is the distance between the front end of the drill and the universal joint, the drill swivelling horizontally or vertically, or at any angle round the pivot. For undercutting, a succession of arcs are swept out, one above the other, and the cut is made deeper by using longer and longer drills, until the coal is sufficiently undercut for the purpose. Nicking is carried out by arranging the drill to sweep a vertical arc, and by lengthening the drill till the cut is sufficiently deep. There is no reason why electric percussion drills should not be employed in the same manner, and they should be more convenient and more economical than the compressed air drill. It will be observed that the above

arrangement overcomes all the difficulties that have been mentioned in connection with coal cutting by machines. The drill is light, and takes to pieces, and can be easily transported, while coal-cutting machines weigh from fifteen cwt. to two tons, and are not easily transported.

Electrically Driven Fans

The fan has now practically taken the place of the furnace in all coal mines, and, where ventilation is attempted, is used in all metalliferous mines. The fan employed in mines varies in form, but essentially it consists of a number of blades assembled round a shaft, and when the blades are whirled round, the air enters the centre of the fan and is expelled at the ends of the blades. Plate 30A shows a Heenan fan without its case; Plate 30B a fan in its case, driven by an electric motor; and Plate 30C a fan-house, away from the power station, with a fan electrically driven by three-phase currents.

Description of Different Forms of Fans

There are two principal forms of fans, one of which only has been employed up to the present for mining work. The author knows them as the screw-blade fan, and the centrifugal fan. The screw-blade fan has not hitherto been employed in mines, but there appears to be no reason why it should not be employed in certain cases where only a small pressure is required, as, say, to divert an air current through certain portions of the workings. The screw-blade fan, or propeller fan, as it is sometimes called, merely acts in air, as the screw of a ship does in water, or an ordinary screw does in wood or metal. When a body of metal having the screw formation is rotated, one of three things may happen; it may go forward itself, as when the screw moves into wood or metal; it may move the object to which it is attached through the medium in which it is screwing, as when a ship is moved through the water by the rotation of its screw; or, if the screw is stationary, and the object to which it is attached is stationary, it must move the medium in which it is rotating; and this is what the propeller fan does. If fixed in a window or a door, or a partition between bodies of air, when rotated it transports the air from the one side of the partition to the other. It does not create any appreciable difference of pressure, and therefore is of no service for driving a powerful current of air through a coal mine; but in many of the workings of metalliferous mines, where ventilation is often so difficult, and in cases even in

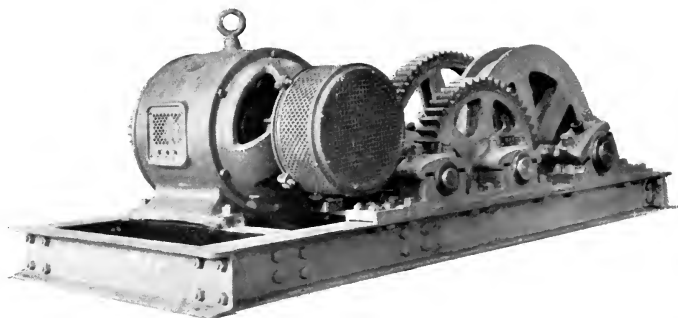

PLATE 27A.—Electrically Driven Endless Rope Haulage Plant, with Spur Gearing by Messrs. M. B. Wild & Co.

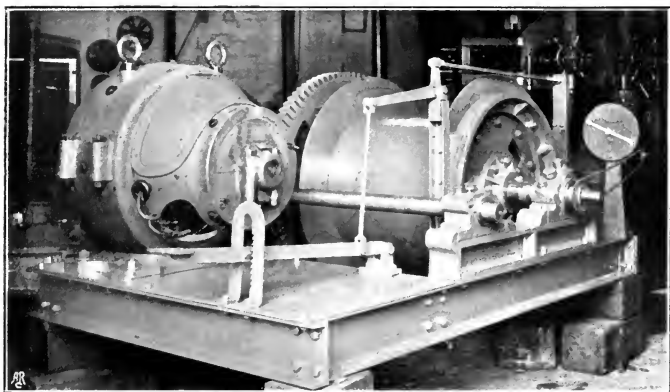

PLATE 27B.—Dip Haulage, or small Winding Plant, Electrically Driven, made by Messrs. M. B. Wild & Co.

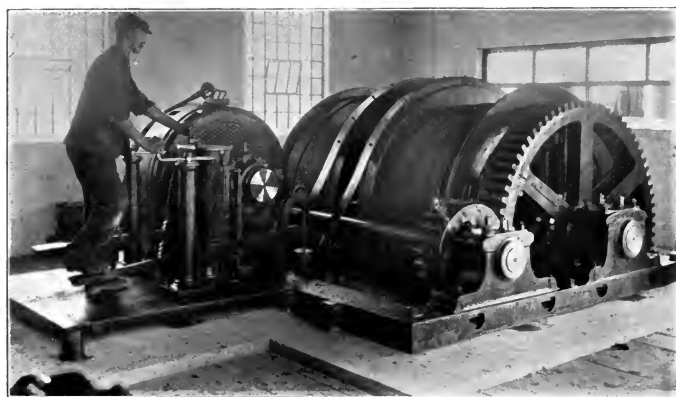

PLATE 27C.—Main and Tail Haulage Plant, driven by Three Phase Motor, as made by the Westinghouse Co.

[To face p. 336.

coal mines where it is sometimes inconvenient to lead the air current through a duct, the propeller fan, if placed in a suitable position, could either force air into the district or the room to be ventilated, or could withdraw the foul air, the pressure it creates being quite sufficient for a great many of these purposes. The propeller fan has a large vogue in ventilating buildings, offices, etc., though its application in many instances is exceedingly crude, it being supposed that for ventilation all that is necessary is to stir up the air in the middle of a room, for instance. The propeller fan is so particularly useful for many cases where intelligently applied, because it is so easily adapted for driving by small electric motors. It is wise, however, when purchasing fans driven by electric motors, to discount very largely the statements sometimes made in makers' catalogues—that they will deliver so many cubic feet of air per minute. The statement is quite correct, providing that the air is quite untrammelled, as when the fan is placed in the middle of a large open space, or a large room; but where ventilation is required, there is a resistance always set up to the passage of the air, as will be explained, and then the quantity of air moved by the propeller fan is very considerably reduced.

The other form, which has been so largely used in mines, is the centrifugal fan. This consists of a number of blades assembled round a central space very much after the manner of the centrifugal pump, the blades being enclosed between discs, and the peripheries of the discs sometimes being open to the atmosphere, and sometimes enclosed, so as to deliver the air to some form of funnel. As with the centrifugal pump, when the blades of the fan are rotated, difference of pressure is created between the atmosphere at the periphery of the fan and the centre, the air thence passing into the centre of the fan and being whirled outwards to the periphery, thence to the atmosphere directly, or through the funnel, etc. In the early forms of fan, the blades were simply radial, but it was found that a good deal of power was lost by the eddy currents set up between the blades, and so, as with the centrifugal pump, later forms have blades curved in the direction of rotation, and the air is guided more or less in its passage to the outer atmosphere. There is one peculiar feature also about all fans, and that is, that in the centre of the fan there is a current of air in the opposite direction to that at the periphery, this being the equivalent of the back pressures electrical engineers are accustomed to deal with in their apparatus, but meaning the expenditure of more power in order to deliver the same quantity of air. In the Capel fan, the air is guided on something the same lines as the water in the modern high lift centrifugal pump, with the result that it is claimed that the velocity of the air is completely got rid of, and is reduced

to an inappreciable amount before it issues into the atmosphere, an *evasé* chimney in which the orifice is gradually expended helping this effect.

The Sirocco Fan

In the "Sirocco" fan, made by Messrs. Davidson of Belfast, a new line has been struck. The appearance of the fan is very much like that of some of the old water wheels, with a number of shallow buckets surrounding the wheel. In place of a small number of long blades, the Sirocco has a large number of very short blades, curved towards their outer ends in the direction of the motion of rotation, and the blades are made very much longer axially than with the other forms of fan. The short blades are fixed between two annular discs, the inner discs being connected mechanically with the driving arrangement, and the internal space, where the air space enters, being many times larger than in the other types of fan. The air also is not confined in any way on its egress, the outlet being also very large. Messrs. Davidson claim to be able to handle a very much larger quantity of air with a given size and weight of Sirocco fan than is possible with other forms.

In all cases the fan is a machine for creating air pressure, or for transporting air from one point to another. In the case of the propeller fan, as explained, the air is merely transported from one side of a partition to another, and very small difference of pressure created. With centrifugal fans, however, comparatively high pressures for air are created, as much as 8 inches of water gauge being created by some of the Capel fans. Air pressure is so small that it is measured in inches of water gauge—that is, the pressure equal to the weight of one or more cubic inches of water. The inch water gauge equals a pressure of 0.55 oz. per square inch, so that a pressure of 6 inches, which is considered very high, is only about $3\frac{1}{2}$ oz. per square inch. This pressure, however, is quite sufficient to overcome the resistance of every coal mine, and in the majority of cases in British coal mines, very much lower pressures, in the neighbourhood of 2 inches water gauge, are found sufficient. British mining engineers prefer to work with low pressures, because they say that as their coals are many of them constantly giving off gas, it is better for the gas to come away freely, and to be carried by the ventilating current into the outer atmosphere, than for it to be compressed within the coal and held there by a powerful air pressure, only to come out with considerable force should the air pressure at any moment be lowered by accident to the ventilating apparatus.

It is usual in coal mines to place the fan at the top of the upcast

shaft, the shaft being closed in, and what is called a fan drift being led from it directly to the centre of the fan, the periphery of the fan being opened either directly or indirectly to the atmosphere. The motion of the fan creates a lowered pressure at its entrance—that is to say, a difference of pressure between the atmosphere at the top of the downcast shaft and the air entering the fan. This difference of pressure is similar in every respect to the difference of pressure, which causes a transference of electricity through a conductor. In fact, the ventilation of a coal mine is similar in almost every respect to the distribution of electricity on the two-wire system. There are two main roads in the mine, leading from the downcast and the upcast shaft respectively, and these are connected by other roads leading to the faces, to the stables, etc., in such a manner that the air passes from the intake road, the one leading from the downcast, across the face, or the portion of the mine to be ventilated, to the return airway, that leading to the upcast. The fan is required to create a sufficient difference of pressure to force a sufficient quantity of air through the main roads and the workings to comply with the Coal Mines Regulation Act. The air in its passage through the roadways, etc., rubs on the sides, and creates friction, the friction being directly in proportion to the extent of the surface—that is to say, to the lengths of the roads, and to the size of the roads. A certain power is required to move the air through the roads, the power being directly in proportion to the square of the velocity, and to the friction, etc. A certain power is also required to create the difference of pressure between the two sides of the fan. The whole thing resolves itself into a certain power being required to drive the fan, and this may be supplied by an electric motor, which is preferably of the shunt-wound continuous-current form. Three-phase motors are employed in driving fans, but a difficulty has arisen in connection with their employment. The fan is often required to vary its speed, not for a few minutes, but for days together, owing sometimes to changes in the barometric pressure of the atmosphere, and sometimes to the fact that the pressure is lowered at week ends, when there is no one in the pit. The variation in speed is not great. Fans run at from 40 revolutions per minute up to 300 revolutions, and a variation of 1 or 2 revolutions of a fan running at 40, and the equivalent on the higher speed fans, is all that is required. This is easily obtained with a shunt-wound continuous-current motor, with very little waste, by varying the strength of the field current, but it is not so easily obtained without waste with a three-phase motor, because a resistance must be put in the rotor circuit of sufficient size to accommodate the whole of the rotor current, and the heat generated in that resistance is wasted.

Electricity cannot compete with steam for driving fans where the

boiler is close to the fan engine, since the fan engine itself is an absolutely constant load, subject to the variations mentioned above, and therefore any economies that can be effected in an engine driving the generator at an electric power station, can be applied directly to the engine driving the fan itself. There are, however, many cases where a fan is placed at a distance from the boilers. It may be required to ventilate a pit where there is no steam, and an electrically driven fan then comes in most conveniently. Also, it often happens that parts of the workings are difficult to arrange for ventilation, and in those cases it should be very convenient indeed to place a fan in such a position that it can be driven by an electric motor without danger, and can either force or suck air through the district to be ventilated. The electrical fan, in fact, should be as useful to mine ventilation in coal mines, and very much more so in metalliferous mines, as the booster is to the electric power distribution.

Power required for Driving Fans

As explained, the power required by a fan is expended in creating the necessary pressure between two surfaces, as the top of the downcast and the top of the upcast pits of a coal mine; between the ends of a road leading to a portion of the workings, and so on; and its necessity arises from the fact that air, like water, when it is driven through any pipe or duct, or the roads of a mine, rubs upon the sides, roof, floor, etc., and in rubbing creates friction, which absorbs power to overcome it. The power required is measured by the product of the quantity of air passing per minute, multiplied by the pressure between the two sides of the fan, the pressure being expressed in the weight of air forming the "motive column," equivalent to the water gauge. To obtain the power, dividing by 33,000, as in other cases, gives the actual horse-power expended in the air.

This is the power that must be delivered to the air. But in all coal mines, and in some other mines, the upcast shaft has a certain ventilating value. The air from the workings is usually at a higher temperature than that which enters the downcast shaft; in addition, it is largely charged with moisture, and the two combined make a column of air in the upcast of smaller weight than that in the downcast, the difference between the weight of the two, which in deep mines may be considerable, being called the "motive column." In the early days of mining, and in some metalliferous mines at the present day, the motive column is the only source of a ventilating current, and it drives the current of air through the workings, and up the upcast pit. With furnace ventilation, the motive column was created by heating the air at the bottom of the upcast pit, and

creating a column of air at higher temperature than that in the downcast. The volume of the motive column is found from the following table:—

$\frac{1}{2}$ "	water gauge represents a motive column of	32.2 feet
1"	"	64.4 "
2"	"	128.8 "

and so on.

The power required to be delivered to the air by the fan will be the amount of power required to be delivered to the air less that furnished by the motive column, where one exists, and the power that must be delivered to the fan blades is this net power equated with the efficiency of the fan, which may be taken at from 44 per cent. to 67 per cent., so that the power to be delivered to the fan pulley is the net power multiplied by $\frac{100}{50}$, say, taking 50 per cent. as an average efficiency.

The power required by the motor driving any fan is again the power required to be delivered to the pulley of the fan, equated with the efficiency of the motor. If we take the efficiency of the motor as 90 per cent., and that of the fan as 50 per cent., the net power required at the fan blades must be multiplied by $\frac{100}{45}$ for the power required at the terminals of the fan motor.

Driving Air Compressors

Compressed air was in the field, for the transmission of power in mines, a long time before any one ventured to hope that electricity would take its present position. Thirty years ago, and before, compressed air was waging a fight with steam, which had been the method previously adopted for delivering power in the mine. Steam is objectionable, because of the losses by condensation in the steam pipes, and because of the dampness which it sets up in the mine workings, which leads to other troubles. Compressed air was a great improvement on this, but compressed air is very wasteful, as already explained. The apparatus employed with compressed air consist of the air compressor, driven by a steam engine, or by water power, or by gas power, the pipe line connecting the compressor with the apparatus that is to use the compressed air, and the engines which use it. There are three sources of loss, apart from the friction of the driving engine. In the first place, when air is compressed, the act of compression heats the air, and this heat is always dissipated, under all mining conditions, before the air is used as a motive power, and consequently the energy expended in heating the air is lost. Further, when the air is heated in compression it

expands, and a smaller quantity of air is compressed at each stroke of the compressor, so that more work has to be done by the compressor to furnish any given quantity of air at a given pressure at the face. The air compressor consists of one or two cylinders, similar to steam cylinders, in which pistons, similar to steam pistons, work to and fro, drawing in air on one stroke, compressing it, and delivering it to the pipe line, or the receiver, on the return stroke. In modern air compressors it is found economical to deprive the air of the heat liberated in it by compression, as far as possible, as it is created. And this has led to the compressor being divided into two and sometimes more cylinders. The air is compressed to a certain pressure in one cylinder, and is forced from there into a receiver, where it is cooled; it then passes into a second compressor, where the compression is completed, and it is again cooled, and is then delivered to a receiver, usually consisting of a boiler without flues, from which the pipe line leading to the face takes its supply. In some forms of compressor, the cylinders are surrounded by water, a portion of which is open to the atmosphere, the evaporation from the exposed surface of the water tending to cool the cylinder. In other forms the cylinders are fitted with water jackets, similar to gas engines, and cooling water is kept circulating through them. The second source of loss is in the pipe line, and it is made up of two portions, the loss of pressure due to the friction of the air passing through the pipes, and the loss of air itself, as explained in a previous part of this chapter, owing to leakage at the joints of the pipes. The loss of pressure due to friction is usually very small, unless the plant is very badly designed; but the loss due to leakage is usually very great indeed.

The third source of loss is in the conversion of the energy stored in the compressed air into mechanical energy in the motor. It is usual to employ ordinary engines made for steam to use the compressed air, and here two sources of loss arise. One that for some time created a great deal of trouble, but which has lately been, the author believes, practically overcome, was the freezing of the moisture contained in the air, in the exhaust ports of the motor cylinder. It is usual to take the air for the compressor on the surface from the surrounding atmosphere, which is always more or less charged with moisture, with the result that the quantity of useful air is less than it would be if moisture were not present, by the cubical content of the moisture. This moisture, if it is allowed to pass on into the pipe line, and from the pipe line to the motor engine, passes from the state of vapour to the liquid state, and freezes in the exhaust ports, partially or wholly closing them up, and in any case creating considerable back pressure, lowering the efficiency of the engine, and decreasing the amount of work it is able to do. The compressed air operates in the motor engine by expanding, just as steam does in steam cylinders, and as

the air in the cylinder of a gas engine does on explosion. But in order that the air shall be enabled to expand, it must absorb heat, and it takes this from surrounding objects; the walls of the cylinder, etc., and its own temperature being also considerably reduced, it can no longer support the moisture it has carried as vapour, the moisture being thereby deposited, and heat being also extracted from it, as well as from the cylinder, etc., the moisture is converted into snow and ice. This difficulty, the author believes, has been overcome in modern plant by allowing the moisture to drain from the pipes before the air arrives at the motor engine. It will be understood that when the air first issues from the compressor, even when it has been subject to the cooling before mentioned, it is still at a higher temperature than that of the surrounding atmosphere, and is able to carry a comparatively large quantity of moisture in suspension. The receiver, however, which is employed with most compressed air plants, and which is usually placed in the open, with a large surface exposed to the atmosphere, cools the air very considerably, and a large proportion of the moisture carried by the air is condensed, falls to the bottom of the receiver, and is drawn off in the usual way. As the air passes through the pipe line, further cooling takes place, though probably in some of the deep mines warming may take place, and there is usually a second receiver near the face, where any moisture is allowed to drain out of the air, and is drawn off. In the author's opinion, it would be far better, and more economical, so far as this part of the subject is concerned, to handle the air on its way to the compressor by a cooling apparatus, such as those employed in connection with the cooling and drying of blast furnace air. This would get rid of the moisture trouble, and it would also raise the efficiency of compression by enabling a larger quantity of useful air to be taken in at each suction stroke of the compressor. The other portion of the loss at the motor engine is the inability, up to the present, so far as the author has been able to ascertain, to use the air in the motor cylinder expansively. In the steam engine, it will be remembered, the steam is allowed to enter at boiler pressure for only a short portion of the stroke, the remainder of the stroke being performed by the expansion of the steam itself, and the efficiency of the arrangement being thereby considerably increased. The two portions of work done by steam in a steam engine may be compared, the first portion to a push by the steam straight from the boiler to the piston, and the second to the expansion of a compressed spring. In the air motor engine only the first portion has been so far utilized. The air enters the motor cylinder from the receiver or the pipe line, and simply pushes the piston to the end. The losses in compression and the losses in the motor cylinder cannot be avoided by the use of electricity, except, perhaps, the latter indirectly; but the losses in the pipe line may be

reduced by compressing the air near the point of consumption, using an electric motor, taking its power from the supply service to drive the air compressor, the compressed air being used to drive the motor engine as before. This method has long been used in Germany, and was claimed by the Germans to be economical a good many years ago. It has lately been introduced into this country, and is apparently making way, the combined efficiency of the electric drive and the compressed air being claimed to be 60 per cent. at the compressed-air receiver. Fig. 156 shows the relative efficiencies of a compressing plant, with the compressor on the surface and in-by; and Plates 31A and 31B show forms of air compressors electrically driven for

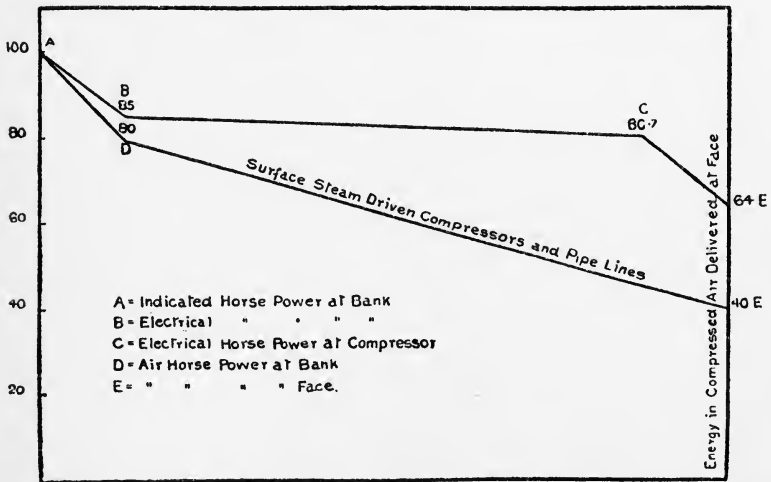

FIG. 156.—Diagram furnished by the Westinghouse Co., showing the Efficiencies of Compressors driven at Bank and in-Bye.

use in-bye. There are one or two difficulties in connection with this arrangement. In the deep coal mines in this country the atmosphere near the face, where the air compressor would be driven, is very warm, a temperature of 80° Fahr. being quite common, and it is also largely charged with moisture, hence the quantity of air taken at each suction stroke of the air compressor will be less than if air at ordinary atmospheric temperatures in this country could be employed. On the other hand, it should be possible, and the author understands that some attempts have been made, to adopt the plan that is employed where air is used for cold storage purposes, and to use the same air over and over again, adding a cooling and drying apparatus to the plant. Objections to this are, that the compressed-

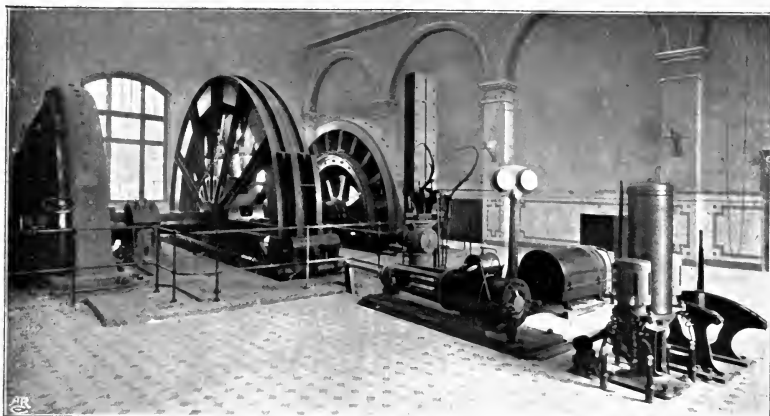

PLATE 28A.—Electrically Driven Winding Plant, by the Electrical Co., as fixed in a German Mine.

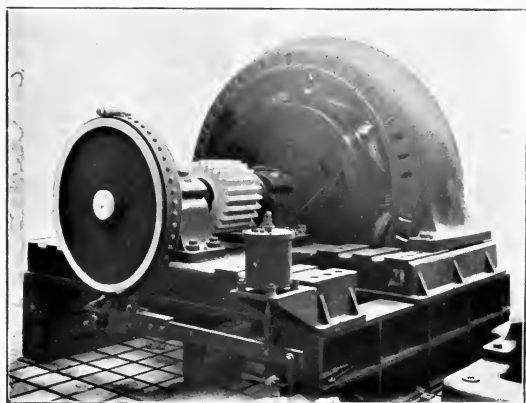

PLATE 28B.—Electric Winding Motor and Brake, as fixed by the International Electrical Engineering Co. of Liege, at the Waihi Junction Mine, New Zealand.

air pipes must be doubled, but as they need not be large, the author believes this would not be serious; and another difficulty is, the neighbourhood of the face of the coal is not a convenient spot to employ cooling apparatus. Still, with a little care and skill in working, it might be done, and in that case the trouble with moisture should be completely got rid of, and the whole efficiency of the plant considerably increased. There is also another point that is worth considering, and that is the employment, in certain cases and under certain conditions, of an electric current taken from the power service to heat the air before it enters the motor cylinder. As in all these cases, the question whether such a course would be economical or not can only be determined by a balance sheet. A certain definite number of heat units may be delivered, say, to a pipe or a receiver, through which the air is passing, and a certain definite proportion of that heat will pass into the air, increasing its cubical content, and therefore increasing the work that it will perform in the motor engine. This current will cost a certain amount to produce in the generating station. It will save a certain amount of current in the motor driving the air compressor. If the saving is sufficient, or if convenience comes in, and increases its value, as often happens, it may be worth applying, but the engineer in each case must put down the cost on both sides and compare them. In the very early days of electric lighting, the author put down a small electric-lighting plant in a colliery nearly half a mile deep, where compressed air was the only means of driving, and to get over the trouble of the moisture freezing in the ports of the driving engine, he heated the air passing into the engine cylinder by means of the current that supplied the lights. The method was successful, but he is not prepared to say that it was economical.

Power required for Driving Air Compressors Underground

The power required to drive the air compressor underground is found by taking the power required to compress air at the temperature of the atmosphere in the neighbourhood of the compressor, and with the moisture that is usually present there, from the atmospheric pressure there, up to 60 lbs. or 80 lbs. per square inch, whatever may be the pressure employed. It will be understood that each cubic foot of air requires the expenditure of a certain quantity of energy to compress it from the atmospheric pressure to 60 lbs. or 80 lbs., as the case may be, and where the air is at a higher temperature than the average, taking the average in this country as 60° F.—in America it is taken at 70° F., and in tropical countries it would of

course be higher—more energy is required to be expended than when it is at the average temperature, and with the average quantity of moisture. Taking the average temperature where the air compressor would be fixed in a colliery at 80° F., each cubic foot of air would require from 0·5 to 0·7 H.P. to compress and deliver it at 60lbs., and from 0·76 to 1·0 H.P. to compress and deliver it at 80 lbs. So that it is a simple calculation to find what horse-power is required to compress a certain number of cubic feet per minute, to a given pressure. This horse-power is to be delivered to the piston or pistons of the air compressor, plus the power required to overcome the friction of the compressor itself, and the power required to be delivered at the terminals of the electric motor driving the compressor will be found by equating the efficiency of the compressor with the efficiency of the electric motor, as explained in previous cases.

Electric Locomotives

The electric locomotive has not been, up to the present, employed in mines in the United Kingdom, but it is largely employed both underground and on the surface in America and on the Continent, and in gold mines in New Zealand, and the author believes would do good service in certain cases in this country. The mining electric locomotive is a small copy of the railway electric loco. It consists of a carriage, of the form shown in Plates 25B and 26B, mounted on four wheels arranged to run on the mine waggon tram rails, and carrying a motor, usually of from 9 H.P. upwards, geared to one axle of the wheels. The carriage carries a seat for the driver behind, a head light in front, a short trolley pole, which is again very similar to those used on tram lines and railways, but smaller, and a controller of a similar type to those employed on railways, with the usual brake, both at the driver's hand. The loco takes its current from an overhead copper wire, suspended over the middle of the track, the return current being by means of the rails, the current passing from the motor to the wheels and thence to the rails. The pressure usually employed with mine locos is 500 volts, but it will be, of course, that of the service. There is another form of electric locomotive employed in Germany, of which one was exhibited at the Glasgow Exhibition, in which a battery of accumulators is employed, instead of the trolley pole and trolley wire. This is, of course, a much safer arrangement, but it is doubtful if it is so economical, for the reasons that have been explained in connection with accumulators.

The trolley employed in America with mine locomotives is nearly always the wheel with which every one is familiar as employed on electric tram lines. In Germany, however, two modifications are

employed. In one there is a roller about two inches in diameter, of aluminium, the roller extending nearly the whole width of the track, and being supported by uprights from the top of the locomotive. This has the advantage that it is not easy for the trolley to get off the trolley wire, and any wear due to sparking is distributed over a very much larger surface, while it should also be much more easy for the loco to go round a curve, than with the wheel trolley. The other arrangement, which is coming into use very much in Germany on electric railways, is the bow trolley. It consists of a rectangular bow of stout wire, held in the position usually occupied by the trolley pole and wheel, and it rubs against the underside of the trolley wire. It has the advantage that it is not necessary when reversing to turn the trolley pole round; the bow trolley reverses itself when the locomotive has run a certain distance back.

For surface work in mines in the United Kingdom and elsewhere, the author's view is that electric locos would be of great service, and there should be no difficulty whatever in arranging overhead trolley wires. The locomotives can be small, for hauling mine waggons, or they can be large enough to handle railway waggons. For underground work, however, it is very doubtful whether, except on the main intake roads, it would be wise to employ the electric locomotive. Its use necessitates a bare conductor overhead, the pressure of the service being present at every point of the conductor, and there being the consequent danger of workmen and others getting shocks from it. In some mines in America, the difficulty has been overcome by enclosing the trolley wire inside an inverted wooden trough. This should protect miners from shock, as long as the trough is perfect, but the author would be afraid that the trough itself, becoming wet, would set up considerable leakage on the trolley wire.

The Electric Driving of other Machinery about the Mine

In the foregoing pages the author has described the principal machines to which electrical driving has been applied, mainly because of the efficiency of the electrical method of transmitting power to a distance, but when once electrical power is on the ground, it may be employed, and usually economically, for driving any and every machine about the place. About the surface of every mine, coal or metalliferous, there are nearly always isolated engines taking steam from the boilers through pipes that are laid in the ground, or sometimes carried overhead, and there are always considerable losses from condensation of steam in these pipe lines, and in addition, when the engine is to be started, the condensed water must be got rid of, the

engine must be very carefully started, or it will knock itself to pieces, and this means time. With an electrical power service, cables may be led overhead, or in the ground, to the neighbourhood of every machine that is to be driven, a motor may be fixed to take the place of the engine that was previously driving, in any convenient manner, either by belt, worm or spur gearing, or by direct connection, and the motor will use nothing, so long as the cables, switches, etc., are kept in order, except when it is doing useful work, and it will always be ready to start quickly, say in a few seconds. This applies to coal-washing machines, which may be, and are, driven by electric motors, fitting-shop shafting, cranes, surface haulage, creepers, pumps for boiler feed at a distance from the mine, stamps for metalliferous mines, or breakers, sizers, etc. The most convenient forms of motors employed, if the service is continuous current, will usually be the shunt-wound motor, with a series coil for starting, if the machine is to start against a heavy load. Three-phase motors will also be suitable, and can be of the squirrel-cage type for small work, or where the machine can drive on to a fast and loose pulley; wound rotors being employed for heavier work, where the motor has to start against a load. Electric motors are arranged with spur-reducing gear attached, ready for fixing, to drive any machine that may be required. There may also be apparatus underground, besides those mentioned, that could be conveniently driven by electric motors. Plates 31c and 31d show Blackett's coal conveyer, for taking the coal from the face, in the seams, and delivering it to mine waggons at the gate-end road. It is shown driven by an electric motor.

For each motor there should be a small switchboard, preferably of enamelled slate, fixed to steel supports, carrying the starting switch and resistance, the no-load and overload circuit breakers, and an emergency switch, the whole being enclosed in a lock-up cupboard.

Estimating the Power given out by Steam or Compressed-air Engines that are to be displaced by Electric Motors

It has been explained that it is wise when estimating the power required in any electric motor to drive any given machinery, to take the power given out by the steam or compressed-air engine the motor is to displace. It is sometimes not easy to estimate this. The safest plan is, of course, to indicate the engine, and then it is a simple calculation from the well-known formula. But it will be often very inconvenient to indicate the engine. The engine driving a screening plant, or a battery of stamps, or a sorting plant, often cannot easily

be got at to indicate, and very frequently it must not be stopped for a sufficient time to allow of the measurements being taken. Further, in a very great many cases the engines employed for this work do not work expansively, at least not beyond the ordinary expansion provided by the arrangement of the valves, as the engine leaves the makers. In the great majority of cases, economy of steam is not sought for, where driving of machines is concerned, unless the engine is driving a number of machines through shafting, and it is convenient to make the necessary arrangements for working it expansively. What is usually wanted is that the machine shall keep on working during the full working day, and for that purpose the engine is required to have plenty of power, and further, it is often not convenient for it to be of the larger size necessary, if it is to work expansively. Hence, engines for this purpose are frequently sent out with their valves arranged to cut off at half, or three-quarter stroke, or even not to cut off at all, and the work is done more or less by a push from the steam, coming direct from the boiler. After all, the losses by condensation are far more than any losses due to any working expansively in small engines of this kind. For the purpose of estimating the power that an electric motor to take the place of one of these engines should furnish, it is a pretty safe rule to take the size of the cylinder, the length of the stroke, and the pressure of the steam at the stop valve, applying the usual engine formula. If this rule dictates an electric motor larger than could possibly have done the work, it will be a good fault. The tendency when fitting electric motors up is too often in the opposite direction, and this leads too often to breakdowns that might have been avoided, if a little more power had been given.

CHAPTER VII

FAULTS IN ELECTRICAL APPARATUS

CAUSES of failure in electrical apparatus are known as "faults." A signal bell does not ring, a telephone does not speak, a lamp does not burn, a motor does not run, or any one of these fails in a minor degree. The cause is what is known as a "fault." All faults in electrical mining apparatus are due to one of two causes, frequently to both.

1. The interposition of resistance in the conductive path.
2. The lowering of the insulation resistance of some part of the apparatus.

The interposition of resistance in the conducting path leads directly to apparatus not working as it should do. A bell may ring less loudly, or not at all, a lamp may not give its full light, or may give no light, and so on. The extreme case is, where there is a break in the conducting path, as when the conductor itself is severed, or when some part of the apparatus, some two surfaces of which ought to be in contact, are completely separated.

The lowering of the insulation resistance of any part of the apparatus, such as the insulation of the generator, the cables, the switch gear, leads to current passing through the insulation, which ought not, and this leads to the gradual destruction of the insulation, the further lowering of the insulation resistance, and in addition it lowers the pressure beyond the point at which the leak occurs. Thus defective insulation of some part of the generator will lower the pressure at the terminals. Defective insulation in a pair of cables, say in a mine shaft, lowers the pressure at the pit bottom, and so on. The extreme case of lowered insulation is what is known as a "short circuit," or more frequently a "short," where there is a direct connection, of very low resistance, between two points in the circuit, between which the pressure of the service exists. Lowered insulation resistance often leads to severance of the conductor, because it means that the insulating envelope has been damaged by water or in some

other way, and the water having passed through the envelope to the conductor, gradually eats the latter away, interposing resistance as the chemical action proceeds, and finally severs it. Severance of the conductor also sometimes leads to the destruction of the insulation in the neighbourhood of the severance, because when a conductor through which a current is passing, under considerable pressure, is parted, a spark passes across the break, and in some cases an arc is formed between the severed ends for a short time, the arc destroying the insulation in its neighbourhood and for a considerable distance on each side.

Rules for Testing

There are a few simple rules that are applicable to all kinds of electrical apparatus in testing for faults.

1. Always make sure that the source of electricity, the battery or the dynamo, is doing its work properly, and test it if necessary before proceeding to make other tests, unless, from other indications, it is known that the fault exists in some part of the apparatus away from the source.

2. Always work outwards from the generator in testing for faults, unless there are indications that the fault is in a certain apparatus at a distance from the generator.

3. A great deal of time in testing for "faults" will be saved if continuous tests are made upon the apparatus. If the insulation resistance of each part of the apparatus is tested periodically, and recorded in a book provided for the purpose, it will be seen if any portion is deteriorating, and when this is shown, the earliest opportunity should be taken of making a further complete test of that part of the apparatus. The "test in time" will save whoever is responsible for it a great deal of labour, and troublesome labour, that he will have to undertake if the apparatus is allowed to break down. In nearly every instance, signs are given at a comparatively early date that will enable a careful man to prevent faults occurring.

4. There is a simple rule in connection with all faults, and it is when testing and you come to two points, at one of which you have indications of the normal conditions, or not far from the normal conditions, and at the other you have indications far removed from the normal, the fault is almost sure to lie between the two. Put in another form, when testing, and you have found your current and lost it again, the fault lies between the point at which you last found your current or pressure, and the point at which you lost it. With lighting and power apparatus a good deal of the testing will be made for pressure, and this rule will mean that when you suddenly come to

a very large fall of pressure, without the presence of any apparatus taking a large current to account for it, you will have just previously passed over the fault.

5. In testing for insulation resistance always use a pressure at least as high as that of the service. The strain upon the insulation increases with the pressure, and one will often obtain a false indication, showing an apparently good insulation resistance, with a low-pressure current, when with a high-pressure current the insulation resistance might be completely broken down.

6. In testing for continuity of conducting path, always use as low a pressure as possible, and for practically the same reason as you use a high pressure in testing for insulation. A high pressure will drive a current sometimes through a comparatively high resistance, where a low pressure would declare the existence of the high resistance.

Faults in Mine Signals

Always first test the battery which supplies current to the bell that does not ring. If the battery is tested frequently, it will soon be seen, on testing each cell, if any one or two cells have so far worked down as to interpose a high resistance into the circuit. The battery may be tested by a lineman's galvanometer, which consists of a pair of coils of wire surrounding a vertical magnetic needle, the needle being connected to a vertical pointer which moves over a semi-circular dial, graduated on each side from 0° to 90° . The two coils contain, one a few turns of comparatively thick wire, and the other a large number of turns of very thin wire. One end of each coil is joined to one terminal, and the other end of each coil to a separate terminal, so that there are three terminals on top of the case enclosing the apparatus. The thick wire coil is used for testing the condition of individual cells, the thin wire for testing for leakage currents, and sometimes for continuity of the circuit. One form of lineman's galvanometer is shown in Fig. 157. The battery may also be tested, and perhaps more conveniently under modern conditions, by low-reading voltmeters. Voltmeters are made now to read to five and six volts, in the form of an apparatus that can be carried in the waistcoat pocket. The open type Le Clanché, the dry cell, and the bichromate cells will all give about 1.3 volts when in proper working order, when the voltmeter wires are connected to the terminals of the cell, and this pressure will decrease gradually as the cell is used. When the cell shows only about 0.5 volts, in the case of a dry cell, it should be taken out of the battery and allowed to rest. Sometimes a cell after resting will recover, and will continue to work for some little time. In the case of a wet cell, it may sometimes be recuperated by adding sal-ammoniac, by cleaning the zinc, or adding a

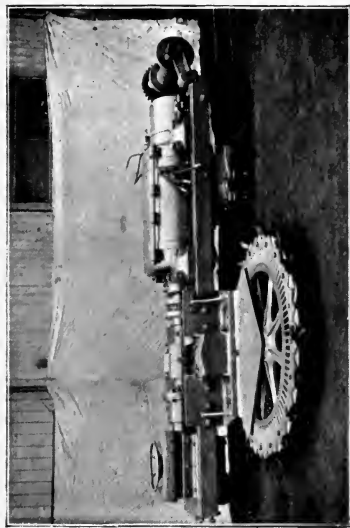

PLATE 29A.—Messrs. Clarke & Stevenson's Electrically Driven Disc Cutting Machine, with Worm Reducing Gear.



PLATE 29B.—Electrically Driven Disc Coal Cutting Machine, made by the Diamond Coal Cutting Machine Co.



PLATE 29C.—Electrically Driven "Pickquick" bar Coal Cutting Machine, made by Messrs. Mabor and Coulson.



PLATE 29D.—Electrically Driven Chain Long Wall Machine, made by the Diamond Co.

fresh zinc, or if these do not suffice, by changing the filled porous cells. The filled porous cell, again, if allowed to rest, will sometimes recover itself, and may be used again. The mercury bichromate cell may be recovered, sometimes by adding bichromate of potash, sometimes by adding a little sulphuric acid, sometimes by cleaning the zinc, and by scraping off the crystals that are formed on the carbon plate. The condition of this cell is known very accurately by the colour of the solution. When in good working order it is a bright orange, it gradually becomes paler, then green, then dark blue. Occasionally a cell of this type will give very little current, even when its solution is a bright orange; it then requires a little sulphuric acid.

Do not attempt to recuperate either dry cells or any other primary battery cells by means of an electric current. Text-book theory states that this may be done. Practical theory says that it cannot, because a number of other chemical actions have gone on within the cell, which cause any recuperation that may be attained to be only temporary. In particular, the carbon plate is almost always attacked, in all forms of cells, by the secondary salts that are formed in the working of the battery, and they are not dislodged, and the carbon plate is not restored, by putting a reverse current through it. In any case, it is far cheaper to change the cells when necessary than to tinker with recuperation.

Having made sure the battery is right, examine the bell for disconnection. In testing signals and telephones, and for a good deal of electric light and power work, a dry cell and either a lineman's galvanometer, or a low-reading ampère meter, will be found very useful. Wherever a disconnection is suspected a circuit is easily formed of the dry cell, the instrument and the apparatus, and the disconnection either found or its presence shown to be non-existent in a few minutes. A somewhat frequent source of trouble with bells is, the ends of the wire coils break off where they leave the coil, or

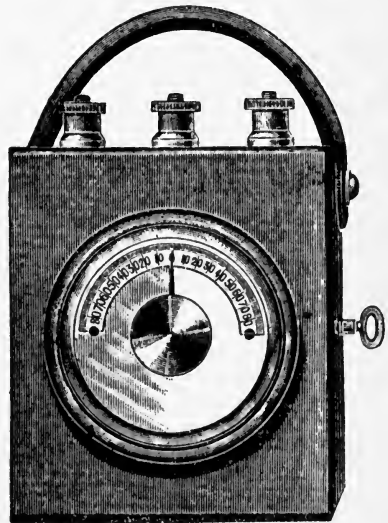

FIG. 157.—Lineman's Galvanometer. Two of the Terminals are connected to the Low Resistance Thick Wire Coils and two to the High Resistance Fine Wire Coils, one Terminal being common to both Coils. It will be noticed that it has a Leather Strap for carrying.

where they are connected to a terminal, and the wire is sometimes held together by the cotton or silk covering. A test will show the presence of this, and a little gentle pulling will disclose the actual fault.

Another somewhat frequent source of trouble with single-stroke bells is, the armature sometimes remains in front of the electromagnet after a signal has been given, in place of falling back. This may be due to a leakage current, or it may be due to imperfect construction of the bell. In either case, there should be a provision for throwing the armature away from the magnet by means of either a spiral or straight spring, as convenient. The centi-ampère meter, so strongly recommended in connection with mine signals, will save a great deal of trouble and time in testing. It will show, as explained, if there is a leakage current on, and it will be a simple matter to increase the tension of the throw-off spring of the bell, when necessary, to keep the armature clear, and keep the bell working till the leakage is got rid of.

To test for a disconnection either in the covered wires, say in the shaft, or the iron wires on the engine road, there is one simple rule. Taking the engine road first—a frequent source of trouble is, coal dust accumulates on the wires, and prevents proper contact being made. Take a voltmeter arranged to read the full pressure of the battery, and test at the commencement of the engine-road wires, and then at different points on the road, proceeding outwards, first with the wires as they are, and secondly, after scraping them. There will be a gradual fall of pressure as the distance from the engine house increases, and if there is a sudden serious fall between any two points the fault will be found between them. A common fault in this case is a badly made joint in the iron wire. In jointing iron wires, the ends should be scraped very clean, and they should either be bound tightly together with iron wire that has also been scraped clean, or they should be twisted firmly together with what is known as a bell-hanger's twist. The fault may also occur in the covered wire between two pieces of road, where the iron wires are terminated on each side of the junction, and covered wire employed to connect them. The difference of pressure on the two sides of the junction will show this. Where the disconnection occurs in the shaft wire, careful test should be made at the top of the shaft and at the bottom for pressure between the wire carrying the current to the bell and the return wire. The existence of a large difference of pressure between the top and bottom of the shaft will show that the trouble is in the shaft, and the shaft wires should then be very carefully examined, every inch of the wire being passed through the hand, and as good a light as can be obtained used. A disconnection will nearly always be shown, by the presence of the green salt of copper, that is formed by the chemical

action between the pit water and the copper wire. It requires, however, some practice in looking for faults of this kind to discover it, and any man in charge of electric signals who examines shaft wires for the first time should go carefully through them several times before proceeding to the next step. The next step unfortunately is one that is unavoidable in mine signals, and it is one which will probably lay the seeds of trouble in the future. Having made sure there is a disconnection in the shaft, a test must be made about the middle of the shaft, by removing the covering from the two wires forming the circuit, and taking the pressure across them. If the pressure that should exist at that point—a little less than that on either the pit top or pit bottom, according as it is a down or up signal—exists, the fault is either below or above, according as it is down or up signal, and the process must be repeated, say, halfway between the middle of the shaft and the bottom, again halfway between that and the bottom of the shaft, and so on, until the section is found in which the fault exists. The places where tests are made should be wiped as dry as possible, immediately the test is complete, and they should also be immediately wrapped with two or three coatings of strip rubber, two or three coatings of primed tape being wrapped over them, and the whole protected by yarn, and so on. These points where tests have been made should be examined as frequently as possible, as no matter how carefully the recovering is done, water will almost surely penetrate, and fresh faults will be made. Leakage on a mine signal is shown by a battery working down very rapidly, and bells refusing to work beyond a certain point. The test for leakage on mine signals is, to break the signal in parts at convenient points, as say the pit bottom, the junctions, and so on, and either observe the effect upon the centi-ampère meter, or if no centi-ampère meter is fixed in the engine house, the effect upon an instrument, which may be a low-reading ampère meter, or the fine wire circuit of a lineman's galvanometer. If the leakage is due to one particular section, as sometimes happens, the fact will be shown by the disappearance of the deflection when that section is taken off, but if, as more frequently happens, the leakage is more or less continuous all the way through the signal, owing to the insulation having generally deteriorated, the fact will be shown by the deflection on the leakage instrument lessening, as successive sections from the end are disconnected.

Faults in Telephones

Faults in telephones are of two kinds, failure of the calling apparatus, and failure of the speaking apparatus. The calling apparatus for private telephone services is nearly always now the magneto

generator and the magneto trembling bell. The magneto generator will show if it is in order by ringing its own bell, or the reverse. In any case, if either the magneto generator or magneto bell is out of order, it is a case for a skilled mechanic.

Failure of the speaking portion may be due either to failure of the microphone portion, the receiver portion, or the switch gear. The microphone battery is a frequent source of trouble, and should be tested, as explained for signal batteries, whenever failure of speech occurs. The failure of the microphone battery will cause the sender's speech not to be heard by the receiver. Another fruitful cause of failure in telephones, not so common now as in the early days, is the

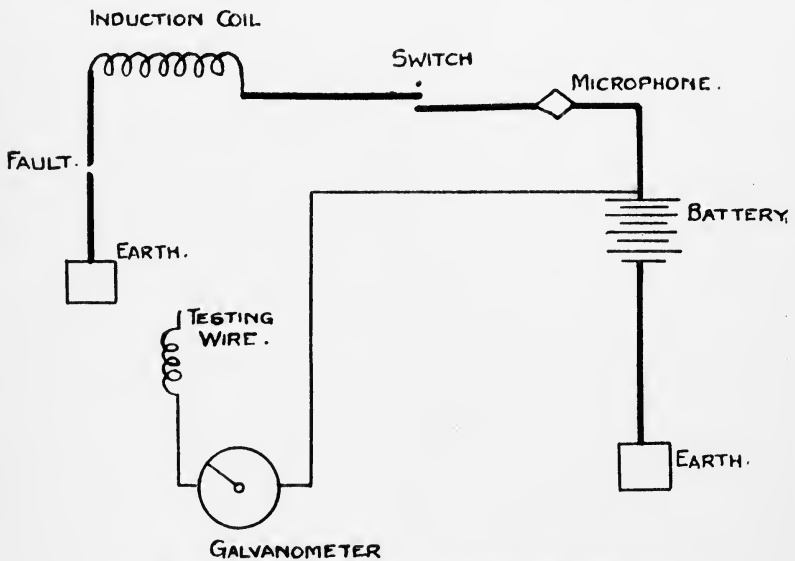

FIG. 158.—Diagram of Connections for testing a Telephone Set.

switch. The hook switch is arranged to put the calling apparatus in circuit when the telephone is on the hook, and the speaking apparatus when the telephone is off the hook, the connections being made by a lever sliding between springs. These springs sometimes work loose, and do not make proper contact, the result being sometimes failure of speech, sometimes intermittent speech. Another cause of failure is, the small wires that are employed in the small induction coil, fixed in the telephone transmitter, may be broken at the coil, or at one of the screws where they are connected. Either of these breaks would cause speech to be broken completely. All of these things may be tested with the dry cell and the lineman's galvanometer, or

low-reading ampère meter, making up the different circuits through which current should pass with the dry cell and the instrument in the circuit, and testing from point to point within the apparatus, till two points are reached, at one of which a deflection is shown, and at the next no deflection. The break lies between these two. The microphone battery, or the ringing battery, where one is employed, may be used for testing for a disconnection. Fig. 158 shows the connections for testing, using the ringing battery.

It is not often that leakage interferes with the working of telephone apparatus, because the currents are so small, and the pressures are also so small.

Faults in Dynamo Machines

Dynamo machines, both generators and motors, are subject to the two faults mentioned, lowering of the insulation resistance, and increase of conductivity resistance. If the insulation resistance of the field coils is lowered, and particularly if the insulation of one coil disappears completely, that is to say, if the coil is short circuited, the pressure generated by the machine will usually be lowered, and the other field coils will show an increase of temperature above that usual under ordinary working conditions. The rule, therefore, is, in a case of this kind, to look for the coil which is cool, and test its conductivity and insulation resistance. If, as sometimes happens, the insulation between the inner wire and the outer wire has broken down, and the coil is practically short circuited, this will be shown immediately by the conductivity resistance test. Each field magnet coil has a certain resistance, which the electrician in charge of the apparatus should know, and should obtain from the manufacturers when the apparatus is first put into service, and if, having disconnected this coil and tested it, as will be explained, he finds the resistance is very much lower than it should be, the cause is probably the insulation has broken down.

The above applies equally to the field coils of continuous-current or alternating-current machines.

Faults in Continuous-current Armatures

The principal points where faults occur in continuous-current armatures are, at the commutator, and between the coils and the iron core. As explained in Chapter IV., the two ends of adjacent coils are brought to the radial bar of a section of the commutator, and are there sometimes merely soldered, sometimes screwed and soldered. If the soldering has not been very carefully done, if the slot in the

radial bar has not been thoroughly cleaned and thoroughly tinned, and the ends of the coils also thoroughly cleaned and thoroughly tinned, and when the two are married, the whole thoroughly filled with solder, and kept hot until the whole has become one solid mass, and then allowed to cool so as to form a solid mass, the vibration of the machine will sometimes gradually break the wires away from the commutator, and a very troublesome fault indeed is set up. When a break occurs at the commutator, the machine refuses to give any current. A small spark is seen at the commutator, but no pressure, or very little, appears at the terminals of the machine. When the fault is due to the wires coming away from the commutator bar, if the machine is stopped and the commutator examined, it is often very difficult indeed to find the faulty one, because the wires will partly go back into their place. The rule is, note the point where most sparking occurs when the machine is running, and examine the commutator connections in its immediate neighbourhood. Failing this, it is necessary to try to break the connections one by one, or to endeavour to force the wires out of their slots. The wire that is loose will then usually come out with comparative ease. Great care, however, is necessary in doing this. The other principal sources of trouble, the connection between the coils and the core, and the connection between adjacent commutator segments, or between commutator segments and the axle, are due to the insulation of the coils and of the commutator segments, and of the commutator from the axle being broken down. In modern continuous-current generators and motors there is often a considerable difference of pressure between adjacent sections of the commutator, and there may be between the coils and the core, and between the commutator and the axle. In the modern dynamo, this is fully provided for by special care in the insulation, as described in Chapter IV. But it may happen that defective mica has been used. There are different qualities of mica, some of which will not stand high pressure. Also, with very high pressures, it has happened that nitric acid has been generated in the slots in which the coils were embedded, owing to the generation of ozone, it is supposed, and this has led to the breakdown of the insulation. Every manufacturer also is at the mercy of a careless workman. If a small pin point is left in the slot of an armature, it will work its way through the insulation, and sparking will take place.

There is never any difficulty whatever in discovering the seat of a breakdown of insulation in a continuous-current armature. It declares itself by the damage it does at the point where the insulation breaks down. When the insulation breaks down between the coils and the core, sparking takes place between them, the coils being usually welded right on to the core, and there is nearly always a

considerable liberation of heat in the immediate neighbourhood, leading to the destruction of the insulation of adjacent coils. Where the insulation between two adjacent commutator segments breaks down, there is also no difficulty in discovering the place. The mica plates between the segments are usually burned away in very peculiar forms, sometimes as if they had been nibbled by rats. The same thing applies to the breakdown of the insulation between the commutator and the axle. It will be shown usually in two ways. The coil, or possibly more than one, connected to the segments near which the breakdown of the insulation occurs will generally be burned, and on examining the insulating ring the damage will be disclosed immediately.

Testing for Disconnection in Continuous-current Armature

Testing for a disconnection in a continuous-current armature is sometimes necessary when the break refuses to declare itself, after

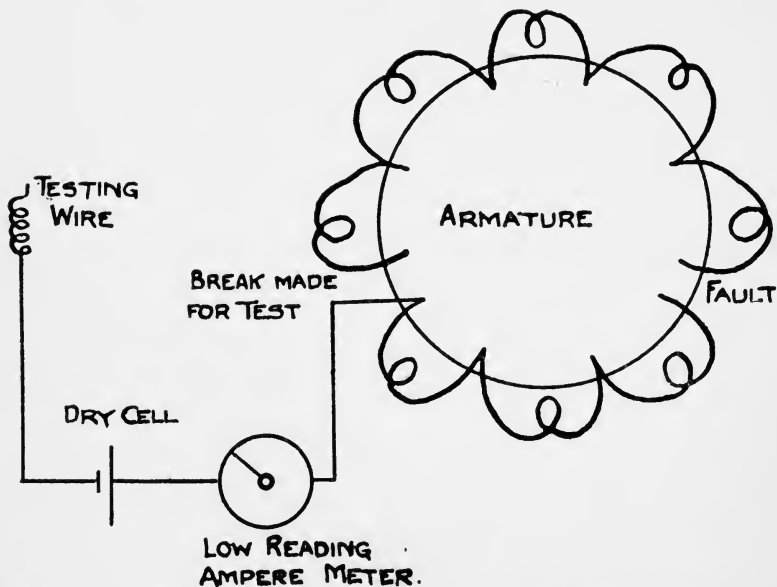

FIG. 159.—Diagram of Connections for Testing for a Break in the Armature Circuit.

the means described have been tried, and it is often troublesome, because there are two circuits. The rule is, make another disconnection

by unsoldering a pair of wires at one of the commutator arms, seeing that the wires are brought quite clear of the commutator and are separated from each other, then form a circuit, as shown in Fig. 158, with a dry cell and either a low-reading ampère meter or a lineman's galvanometer, and test from segment to segment of the commutator on the side of the disconnected wire to which connection is made. The instrument will show the presence of a current as each segment is touched, providing that the commutator and the wire from the instrument touching it are clean, and firm contact is made between them, till the disconnection is passed, and it will be found to lie between the last two segments touched. Usually a further examination will show that the disconnection is at the junction to the commutator. Occasionally, however, though very rarely, the disconnection may be in the coil itself, between the two segments of the commutator last touched. Modern dynamo construction is so well carried out, and is so thoroughly well understood, that the case should very rarely arise where a disconnection in any part of the coil would be found. There may be cases, however, in old dynamos, or where a dynamo has been repaired, and, in place of putting in a completely new coil, a piece has been soldered on. It may also occasionally happen that a bad piece of wire has been used, in spite of all precautions, and it has parted owing to the vibration of the machine. Usually in a case of this kind sparking also takes place at the break, and its presence will be shown by heat of that coil. In any case, however, the coil indicated must be replaced, and the three sets of connections to the commutator and any equipotential conductors properly soldered into place.

Turning up Commutators

It is not so necessary at the present time to caution users of dynamos about turning up commutators as in the early days of the dynamo. The commutator requires turning up very much less frequently than in those days, and it is now better understood that care must be taken in carrying out the operation. The great danger in turning up the commutator is, the cutting tool that is employed always carries forward a portion of the copper it is turning from one segment to the next, in the direction of rotation. Hence, when the turning is complete, there will nearly always be a number of adjacent segments connected by minute pieces of copper that are very hard to see, except by the practised eye. The rule is, after turning up, to carefully clean out the divisions between the sections with a specially sharp-pointed tool, and to go over and over several times. There is, unfortunately, no test that can be employed at a mine that will show

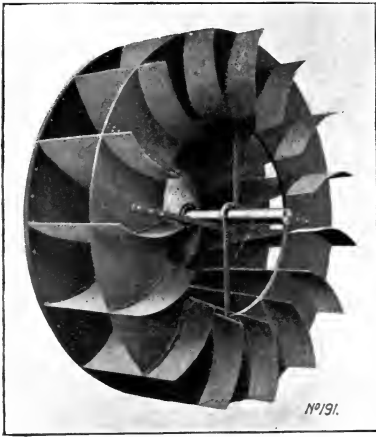

PLATE 30A.—Heenan & Froude's Fan, for Mining Work, without the Case.

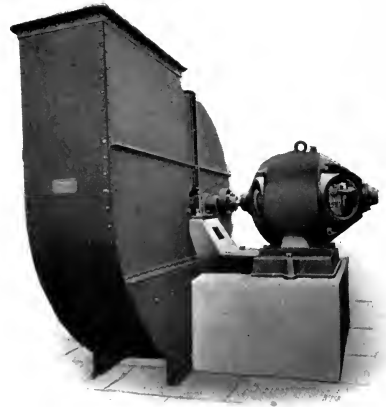

PLATE 30B.—Heenan & Froude's Fan, in Case, with evasé Chimney, driven by an Electric Motor.



PLATE 30C.—Fan House at one of the Lambton Collieries, with one of the Fans driven by a Three Phase Motor. The Wires conveying the Current are shown entering the Tower of the Fan-house. By Messrs. Bruce, Peebles & Co.

[To face p. 360.]

when two commutator sections are in connection. Perhaps the best test is, after turning is complete, and after the divisions have been very carefully cleaned out, the attendant having gone over them several times, to put the armature in the machine, if it has been taken out, and to run it slowly, so as to generate a comparatively low pressure, and to carefully examine the coils while it is running, and after it has been running a certain time, stopping the machine for the purpose. If a connection still exists between two adjacent segments, the fact is generally soon known by the coil that is short-circuited warming, and by sparking at that section. A plan that is designed to avoid all this trouble is to employ one of the machines that are on the market for turning up the commutator *in situ*, by means of either emery wheels or stones, preferably the latter. Care is of course necessary, with this method as with the other, to clear off all dust that is formed from the commutator, the radial bars, and other parts of the machine. It should also be mentioned that dust, either copper or carbon, that is allowed to collect between the commutator segments or on the insulation of the brush holders, will sooner or later lead to trouble.

The burning out of a coil, which occurs when two adjacent segments of a commutator are connected, is due to the fact that the coil itself, being then short-circuited across the insulation of the commutator, presents a very low resistance indeed to the pressure that is created in it as it passes through the magnetic field. The pressure created in each coil is not large. It may not be more than one volt in a well-designed machine; but a pressure of one volt when opposed by a resistance of say $\cdot 001$ ohm furnishes a current of 1000 ampères, and the heating effect being as the square of the current strength, the result is at once apparent.

Testing for Disconnection in an Alternating-current Armature

The testing of an alternating-current armature for disconnection, whether single, two, or three phase, is usually a very simple matter. With single-phase currents a dry cell and a detector galvanometer, or low reading ampère meter connected to the collector rings on the armature shaft, with the collector brushes thrown back, will show at once if there is a disconnection. If a circuit is formed with the dry cell and indicating instrument and one of the collector rings, the wire forming the other end of the circuit, being touched on the junctions to successive coils of the armature, will quickly declare where the break is. The instrument will show a current at the end of each coil, until the coil is passed in which there is a

disconnection, and it will be in the coil between the last two tests. Disconnections do not often occur in alternating-current armatures. With two-phase armatures, the same process is carried out, testing the coils of each phase separately.

With three-phase armatures, star connected, the same process is carried out, but by forming a circuit with the dry cell and indicating instruments as before, and connecting to each two of the three collector rings. If all is in order there is a complete circuit between each two of the rings, formed by two of the coils connected at the neutral point. If there is no circuit between one of the rings and either of the other two, there is a disconnection in that set of coils, and it is to be found by testing from that ring, as described with single phase.

With three-phase mesh-connected armatures, the testing must be carried out in the same way for disconnection as with a continuous-current armature, the points of connection between the coils, of which the winding is formed, being used for testing, in the same way as the commutator segment with a continuous-current armature, and one of them being broken, as explained in connection with the continuous-current machine.

Conductivity and Insulation Tests in Dynamos

There are a number of apparatus on the market for making accurate conductivity tests, and the electrician in charge will be wise to make himself familiar with them, but for all practical purposes any conductivity tests that are required may be taken with a few dry cells, and a low-reading ampère meter. It has been mentioned in the foregoing pages, that a dry cell and a low-reading ampère meter, or a lineman's detector galvanometer, will answer in a great many cases, and it is quite correct. But for greater accuracy, and for better informing himself of the condition of the circuits of the dynamo machines under his charge, the electrician would be wise to use instruments that will show him a certain definite marked deflection, and it may be necessary to use a number of dry cells for the purpose. The conductive resistance of large field-magnet coils may be high. It is no unusual thing to have a field coil having 1000 ohms resistance. Taking the pressure available from a single dry cell as probably not exceeding one volt, the current passing through the circuit formed with one dry cell, the ampère meter, and a field coil will be only one milliampère. Any convenient form of milliampère meter may be employed for the work, but a sufficient number of dry cells should be employed to give a deflection of 30 degrees or so on a circular dial scale, if one is employed, so that any difference in the conductive

resistance of any magnitude is easily apparent. Fig. 160 shows the connections for testing for a break in the circuit of the field-magnet coils with a dry cell and low-reading ampère meter. In practical work it is rarely necessary to know the conductive resistance of field coils within close limits, but it should be known when the resistance is very largely increased, and when it is very largely decreased. It will be largely increased if the wire is partly eaten away, and it will be largely decreased if the insulation has broken down. Both of these

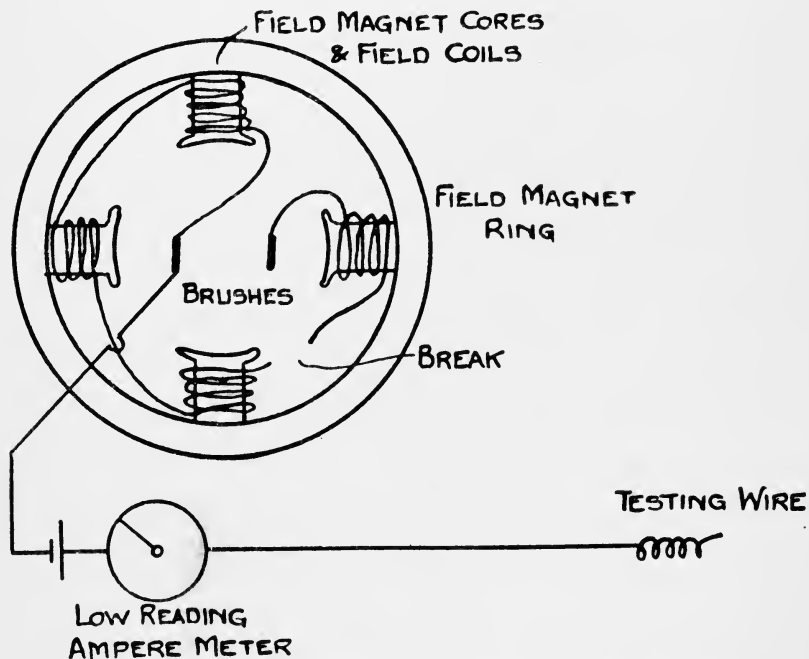

FIG. 160.—Diagram of Connections for testing for a Break in the Field Magnet Circuit.

are shown in the manner suggested, and if more accurate tests are desired, one of the forms of Wheatstone's bridge had better be employed. The author would, however, advise practical engineers not to make a fetish of the Wheatstone's bridge. It is a very beautiful and very useful instrument, especially in the forms in which modern instrument makers supply it, and an electrician who can use one can find out almost anything he pleases with it, but it is an apparatus that requires a certain amount of skill in using. The indicating galvanometer attached to it is always delicate, and

its own measurements are very liable to be upset, and rendered totally inaccurate by a little dirt, or a little carelessness, in putting a plug in its place. A loose plug will upset the most careful measurement.

Testing for Insulation

As explained in a previous part of this chapter, insulation tests must be made always with a pressure at least equal to that of the service. That is to say, on a 500 volt service, insulation tests should be made with from 500 to 600 volts, and on a 200 or 220 volt service with 300 volts or thereabouts. The author does not believe in testing with very much higher voltages than are intended to be employed on

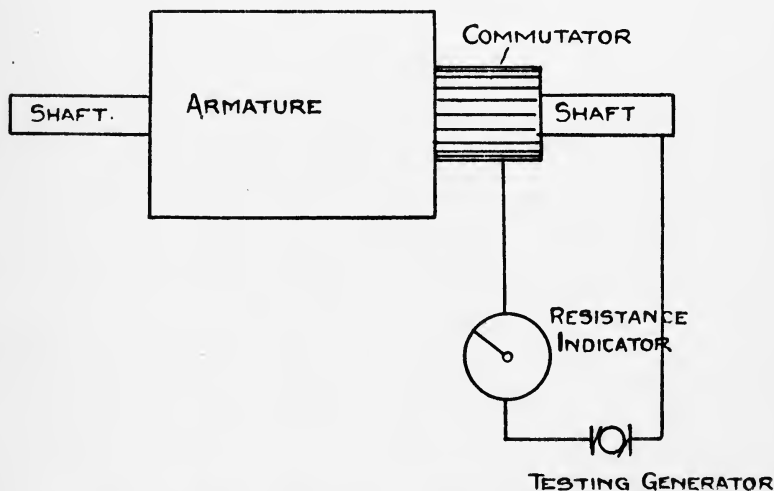

FIG. 161.—Diagram of Connections for testing the Insulation Resistance of a Continuous-current Armature.

the service, even when a dynamo is first made. In his opinion it tends to create possible sources of failure later on. The very best arrangement for testing insulation is one of the numerous apparatus on the market, in which a small dynamo machine, arranged to generate current at from 100 to 600 volts, according to the requirements of the service, is used with what is practically a galvanometer, graduated in megohms. A circuit is formed with the generator, the resistance indicator, and the apparatus whose insulation resistance is to be measured; and the dynamo, which is provided with a handle for

driving, is turned rapidly, the resistance being read off on the dial. The apparatus mentioned are sometimes made with generator and resistance indicator in one box, but more frequently the generator is separate. Fig. 161 shows the arrangement of the test for the insulation resistance of armature to shaft. There are various other instruments, including the Wheatstone's bridge, which may be employed for testing insulation, but they are nearly always very much more delicate than the apparatus described, and unless they are made to be employed with the pressures named, the indications of insulation resistance which they give may be inaccurate.

Trouble with the Brush Holders

As explained in the description of dynamos, the modern dynamo carries several sets of brushes held on spindles, which are supported by a circular rocker, carried on the face of the machine or on the bearing, each spindle being insulated from the rocker by collars of insulating material. This is one of the weak points of the continuous-current machine, inasmuch as the construction leaves very little room for thickness of insulating material. In the modern machines, however, it is not often that trouble arises from the breakdown of the insulating collar, but it is wise to remember the fact that if copper or carbon dust, or even coal dust, are allowed to collect upon the surface of the insulating collar, as they will do if the latter is damp with oil or water, a path is gradually formed, across which a current is thrown at some favourable instant when the pressure of the service rises for a moment, the current so passing burns up the path of dust, and, in burning it, destroys the insulating collar. To avoid this, always keep every part of the brush gear scrupulously clean and free from dust.

Another source of trouble that is sometimes met with in connection with brush holders is—and it applies also to the collectors of alternating-current machines—a disconnection is formed at some portion of the brush circuit by a film of oil or dirt, or the two combined. When a machine is running continuously, it sometimes happens that oil finds its way to the brush spindles, and the other points where connection is made between the coils of the machine and the brushes. So long as the machine is running, nothing may happen, because the screws and other parts being in their place, and properly tightened up, the oil and dirt do not get in between; but when the machine is stopped, and possibly the brush holders removed for trimming, the dirt and oil may extend to the point where the connection to the brush holders will be made, or the brush holders may be fixed at a slightly different spot, with the result that a resistance is interposed, sufficient to prevent the machine from generating the

current required to build up in the first instance. The remedy for this is, keep all parts of the brush holders, etc., scrupulously clean, and, whenever they are dismantled, see that all parts where connections are made are clean and bright.

Faults in Cables

Cables are subject to the same faults that have been mentioned, increase of conductive resistance, and decrease of insulation resistance, and it is more particularly in cables that the one often leads to the other. A cable in a damp place may have its insulation resistance gradually lowered by the water penetrating, and afterwards the water which has passed through the insulating envelope may eat away

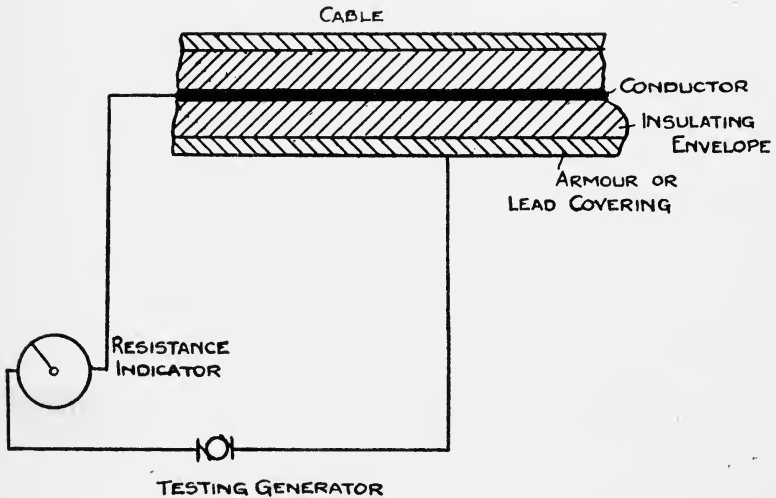

FIG. 162.—Diagram of Connections for testing the Insulation Resistance of an Armoured or Lead-covered Cable.

the conductor, gradually increasing its conductive resistance until severance is complete. This may take place even with the very largest cables, though it is more likely to with smaller ones. The best safeguard against faults of both kinds are the tests required by the recently issued Home Office Regulations. The insulation resistance of each length of each cable should be tested periodically, with one of the apparatus mentioned and the test recorded, and if any particular cable shows signs that its insulation resistance is falling, it should be carefully examined. Figs. 162 and 163 show

the connections for testing the insulation resistance of armoured or lead-covered and plain-covered cables respectively. It is not so easy to test the conductive resistance of cables, because it entails disconnections which are troublesome, and the cables themselves are of such low resistance that a conductive-resistance test is very difficult to make accurately. Probably the best guide in the matter of the conductive resistance, and even of the insulation resistance, is a careful watch upon the volt meters and ampère meters at the main switchboard and sub-switchboards, assisted by tests, as often as possible, at distributing points, motors, and so on. If the current passing out to any particular district through a set of feeders increases without any apparent reason, if the motors taking current from the particular feeders are doing the same work, and there are the same number of

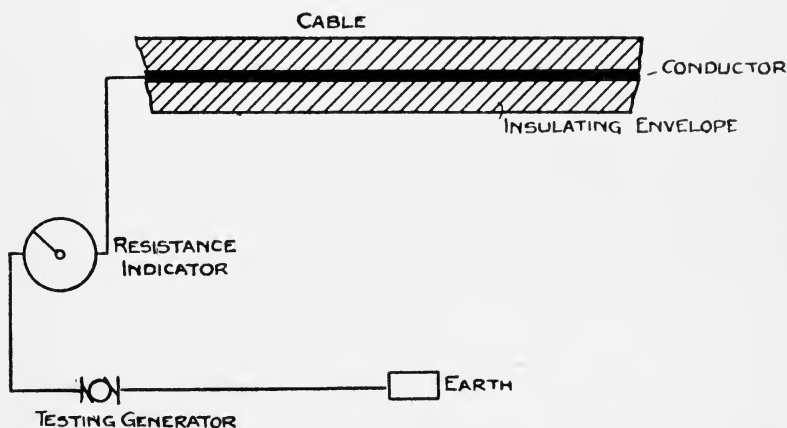

FIG. 163.—Diagram of Connections for testing the Insulation Resistance of a Cable without Armour or Lead Covering.

lamps, of the same power, where lamps are in use, and the current steadily increases, it is a pretty sure sign that the insulation resistance is decreasing. The rule in this case is to break the cable at the different points where the switches are, and test each section for insulation separately. If one section shows a largely decreased insulation resistance it should be carefully overhauled, and, if practicable, divided into sections, by breaking at points where convenient and testing each section separately. If, as more frequently happens, the insulation resistance is found to be steadily decreasing through the whole length of the cables, it means that the whole of the insulating envelope is deteriorating, and it should be carefully watched, and the cables replaced before the matter has gone too far. Another source, and a very frequent one, of trouble

in connection with cables in mines is damage to the cables from falls of roof. The damage may take different forms. The two or three cables may be completely severed, the severed ends remaining bare, and often an arc forming between them, until the fuse or the circuit breaker operates. There is no difficulty in finding this fault, and it only requires careful rejoining. The cable, however, may not be severed, but where there are two or three cables in one the conductors may be forced, more or less, through the insulating envelope, and the insulation resistance between them will be lowered. Where single-armoured cables are employed, it very frequently indeed happens that a fall forces the armour through the insulating envelope to the conductor. In both of these cases the connection between the conductors, or between the conductor and the armour, may be completed at once, or it may be only partial, and the insulation resistance will not only be lowered, but the resistance to sparking also, with the result that at some later time, when some change takes place in the circuit, as when a large motor or several motors are switched off, and there is a large rise of pressure, a spark will pass between the conductors, or between the conductor and the armour, connecting the two together. Sometimes an arc will be formed after the spark has passed, great heat being generated in the neighbourhood, the insulation being damaged, and possibly pit props or coal dust set fire to. When this latter occurs there is no difficulty in finding the fault, but it is wise to endeavour to prevent the fault occurring, and to carefully test any section of cables that has been subject to falls, for insulation, as soon after the fall as possible. Careful testing, as explained, will often save a great deal of trouble at a later date. If the insulation test shows that the insulation has been considerably lowered, that section of cable where the fall has taken place should, if possible, be immediately renewed, or, at least, a piece where the damage is known to have taken place, that has laid right under the stones from the roof, should be cut out and replaced.

Finding a Short Circuit between Cables

If the service is properly protected by fuses and circuit breakers, these will come into operation when the short circuit occurs, but it is sometimes a little difficult to find the exact position of the connection between the cables forming the short circuit. The electrician in charge of the plant will usually have local knowledge of his cables that will assist him in locating the trouble; but where the local knowledge is not sufficient, the following may be useful. A conductive resistance test may indicate approximately the position of the "short." Thus, if there are two cables of a certain size going

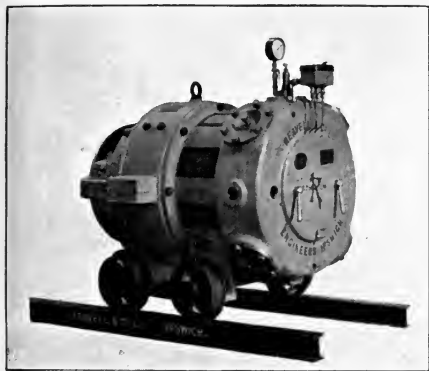

PLATE 31A.—Reavell's Air Compressor with Electric Motor. Portable Form, arranged for placing anywhere in by.

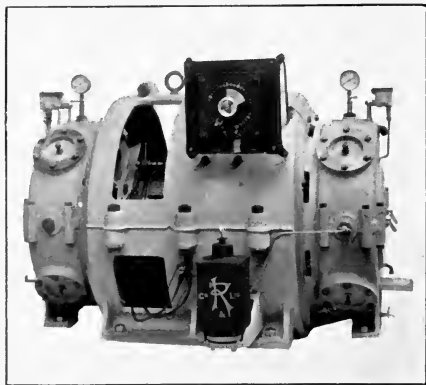

PLATE 31B.—Reavell's Electrically Driven Air Compressor, with Variable Speed Motor, Starting Switch, and Speed Regulating Resistance complete.



PLATE 31C.—Blackett's Underground Coal Conveyor with Three Phase Motor. The Trough shown on the Right is the Conveyor.



PLATE 31D.—Blackett's Underground Coal Conveyor, for use at the Face of the Coal, driven by a Continuous Current Motor. The Coal is seen coming out on the Conveyor and tipping into the Tub at the End of the Road.



down the shaft and along the workings to the neighbourhood of the face, each thousand yards has a certain conductive resistance, and a test with a low-reading ampère meter and a dry cell will give a rough indication of the length of cable between the point where the test is being made and the "short." Further, the system that has been so strongly recommended in these pages, and that is insisted upon so wisely by the Home Office Regulations, of switches at the pit bottom, and at different distributing points, will be found of immense service in testing for a fault of this kind. Thus, if the switches at the pit bottom are open, and it is found on switching the feeders on at the switchboard that the circuit breaker comes out, or that there is a heavy throw of current on the ampère meter, it is pretty clear that the fault is in the shaft. It is wise in a case of this kind not to wait for the circuit breaker, but to watch the ampère meter. If, on the other hand, there is no throw of current on the ampère meter, and the circuit breaker does not move, it is clear that the fault is beyond the pit bottom, and this may be repeated until the section in which the fault occurs is located, when a more careful examination should be made, and a more careful test for conductive resistance.

Testing Cables for Disconnection

This is often a very troublesome matter. The capacity test given on p. 370 is of service, but, as will be explained, the apparatus employed is somewhat delicate. Disconnections do not often occur with large cables; but, on the other hand, it is perfectly possible for them to, especially at joints. Jointing large cables is somewhat difficult in mines, and if moisture, especially some of the pit water, is allowed to be present when the joint is covered up, it will assuredly eat the conductor in two, and then it is difficult to find. A conductive resistance test in this case is of not much value, because if the severance of the conductor is complete, no circuit can be formed, and that is where the capacity test comes in, as no circuit in that case is wanted.

A voltmeter test will do a great deal in locating the section where the break is. If there is a voltmeter at the pit bottom, and it shows the same pressure as at the main switchboard, when no current is passing, it will be evident that the fault is not in the shaft. This had better be confirmed by taking the pressure when the normal current is passing, if possible, as the passage of the current may break down the fault. Passing outwards from the pit bottom with a portable voltmeter, a test at the end of the next section with the current on and off will show whether the fault is in that section, and this may be continued at the end of each section. When the pressure

is lost between the ends of two sections, the fault will lie in that section, and if a careful examination does not disclose it, the section should be replaced. This method applies equally to continuous current and to three phase, bearing in mind that there should be a pressure between each of the three cables of a three-phase service, and that if there is no pressure at the end of any section between one of the cables and either of the others, there is probably a disconnection in that cable in that section. But it is sometimes troublesome, and even dangerous, to test in this way on a medium, and more so on a high pressure service, because of the danger of shocks to the operators when making connection to the cables with the voltmeter. This can be provided for by means of insulating handles attached to the end of the voltmeter wires; but the safer method is as follows:—Pass a current of low pressure through the cables either by running the generator slowly, or from a battery, or from any convenient source, with an instrument in circuit; it need not register ampères, it need only show the presence of a current, and the cable must be broken into sections, as before, the ends of each section being connected together so as to form a circuit. If, for instance, the switch at the pit bottom is opened, and the terminals of the cables at the pit bottom switchboard are connected, the instrument will show a current if the cables in the shaft are all right. Having ascertained that the cables in the shaft are right, the switch at the pit bottom would be closed, the next section thrown in, tested in the same way, and so on. The fault will be in the section last tested where the indicator shows no current.

Tests by Electrostatic Capacity

The question of electrostatic capacity has been brought into mining work from the difficulty of carrying out the Home Office Regulations in the matter of leakage indicators, with three-phase services, owing to the capacity of the cables. The author would hardly advise mining engineers to trouble very much with capacity tests, but, on the other hand, if their electrician, or any one about the mine, acquires a considerable skill with electrical instruments, the capacity test in the case of a disconnection or a short circuit may save some time. The rationale of the test is this. Each length of cable with its insulating envelope has a certain electrostatic capacity at a given pressure. The electrostatic capacity is measured by charging the cable from any convenient source of continuous current for a certain time, and then discharging through a special form of galvanometer made for the purpose, and noting the throw of the galvanometer needle. A formula which need not be given here gives the capacity of the cable under test, with the given pressure

and galvanometer. If capacity tests are made upon all the cables, and a disconnection or a short circuit occurs, the capacity test will show it, and the lowered capacity of the cable under test will show approximately the point where the fault occurs. This is one method; there are others more complicated, and involving more delicate apparatus.

Faults in Switch Gear

Faults are caused in switches, circuit breakers, etc., by the wear of the moving parts by sparking between the contact surfaces, and by the deposit of dust upon the insulating surfaces separating parts of the switch, between which a pressure exists. Care is the great secret in avoiding these. Switches should be carefully watched, and as they wear they should be either taken up, if their construction allows, or their contacts replaced. If the wear is allowed to go on, sparking will take place, often followed by arcing, with the result that the switch itself may be destroyed. If dust is allowed to collect as described, it may and has happened, that at some moment when there is a temporary rise of pressure in the service, a current passes through the dust, burning it up, generally leaving an arc behind it, and destroying the insulating material and the contacts, etc., in the neighbourhood. When these things occur there is no difficulty in finding them, they are only too evident. Carefully dusting, and watching the conditions of the contact services of switches, etc., conductive resistance tests made from time to time, as opportunity offers, will be found to be of assistance. The same useful set, the dry cell and low-reading ampère meter, will be found of value for this purpose; but it will only be of value if tests are made when the condition of the switch is good. If the electrician tests the contact resistance of a switch by means of the apparatus described, by noting the current passed through it from his dry cell, and he tests it later on and finds that with a cell giving the same pressure and with the same instruments the current is less, it will be a sure sign that the contacts are wearing. There may be no harm done to them. There may still be sufficient surface in contact to carry all the current, but if the wear is allowed to continue, sparking will result sooner or later, and possibly heating at the surface will take place sooner.

As mentioned at the beginning of this chapter, in using a dry cell for the tests that have been mentioned, always test the cell itself before proceeding to make a test with it. It will not matter very much if its pressure has decreased, so long as the electrician knows it, in the great majority of cases. But if he does not know it, he may often obtain misleading indications.

INDEX

A

- Absorption of electricity by insulating envelope of cables, 17
- Accumulators, 10, 193
- Advantage of high pressures for distribution, 235
- Ageing of iron, how provided against, 206; in transformers, 205
- Air-cooled transformers, 206
- Alternate-current arc lamps: difference in light given from continuous current, 54; difference in pressure required from continuous currents, 54; difference in wasting of carbons, 54; general description, 54
- Alternating and continuous currents, difference between, 14
- Alternating-current arc lamps: precautions for working, 61; use of choking coils and compensators with, 60; use of compensator with, 65; worked from single-phase service, 60; worked from two- and three-phase service, 60
- Alternating-current generator: description of, 185; difference from continuous-current generator, 185; the disc form, description of, 186
- Alternating current: maximum pressure present, 15
- Alternating currents: calculations for Ohm's law, 15; changes in, 15; the cycle, 15; the cycle or period defined, 15; definition and explanation of, 14; laws governing, 15; maximum currents, 15; maximum pressure, 15; mean heating values, 15; the period, 15; periodicity, definition of, 16; ratio between maximum and effective current, 15; ratio between maximum and effective pressure, 15; square root of mean square, 15
- Alternator with drum armature, description of, 187
- Alternators: the number of cycles of, 191; number of poles in, 191; periodicity of, 191
- Aluminium conductors, objections to the use of, 212
- Aluminium: unsuitable for fuses, 266; use of, for conductors, 212
- Ampère, the, 5
- Angold double-carbon open-type arc lamp for rectified current, 55
- Angold enclosed arc lamp, with adjustable resistance, 51
- Angold open-type double-carbon arc lamp, 53
- Application of electricity for driving machines in mines, 272
- Arc lamp: arrangement of supports in engine houses, 65; arrangement of supports in sidings and open spaces, 65; arrangement of supports on pit heaps, 65; burning away of carbons, 46; general description and working of, 45; insulation of, from support, 65; iron posts for, description of, 65; lattice-work poles for, 66; L. E. F. support for, 67; Schaeffer contact support for, 67; Schaeffer safety hook for, description of, 67; use of flexible stranded rope for hoisting, 65; wooden posts for, 65
- Arc lamps: continuous current, use of resistance with, reason for, 62; fixing of carbons, 46; flickering of carbons, 46; forms of, in use in mines, 45; working of, from motor generator, 59
- Arc lighting by continuous-current machines, 178
- Armature coils, connection of, to commutator, 175
- Armouring bitumen cables, 218
- Armouring cables: objections to, 230; the question discussed, 230
- Arrangement of apparatus in generating station, 206

- Arrangement of arc lamps : to work 100 to 500 volt services, 59; on 65 to 110 volt services, 59
- Arrangement of cables with two- and three-phase currents, 242
- Arrangement of lamps : in parallel series, 8; in series parallel, 8
- Asbestos-covered fuses, description of, 267
- Atkinson's time-limit circuit breaker, description of, 270
- Atom, the, 1
- Atomic theory, 1
- Atomic weight, the, 1
- Attraction between positive and negative corpuscles, 2
- Automatic cutouts for continuous-current arc lamps, description of, 63; use of, with continuous-current arc lamps, 62
- Auto transformers for three-phase motors, 279
- B
- Babcock and Wilcox boiler : description of, 91; description of superheater, 92
- Balancers, description of, 200
- Bar coal-cutting machines, description and operation of, 326
- Batteries employed for mining signals, 27
- Belliss engine, 120
- Bells : for mining signals, 35; for use in damp situations, 36; for use in explosive atmospheres, 35; for use in metalliferous mines, 36
- Binding wires for engine-road signal wires, 30
- Bipolar continuous-current generators, description of, 171
- Bitumen : composition of, and preparation for use as an insulator, 218; covered cables, 218
- Blackett's coal conveyer for the coal face, 348
- Blast-furnace gas : cleaning of, 153; *rationale* of, 153; the use of, 152
- Boiler, circulation of feed water in, importance of, 109
- Boiler efficiency, lowered by deposit of salts, 108
- Boiler feed, by injectors, explanation of, 112
- Boiler-feed pump : electrically driven, description of, 111; three-throw type, 111; with variable stroke, 111; Worthington Co.'s, 109
- Boiler-feed water : containing salts, effect of, on boiler, 108; methods of supplying, 109
- Boiler furnace, temperature of, 101
- Booster : description of, 197; panel, 246; use of, 196; use of, for charging accumulators, 196
- Bord and pillar system of coal working, 325; American modification of, 325
- Branch circuits, current passing in, 6
- Breaking circuit, 6
- Bridge fuses, 267
- Bringing machines into service and taking out with bus bars, 249
- B. Th. Unit : definition of, 99; mechanical equivalent of, 100
- B. T. H. Co.'s enclosed arc lamp, 51
- B. T. H. Co.'s high tension oil immersed switch, 253
- Brockie-Pell brake, mechanism for arc lamp, working of, 48
- Brushes, the office of, in commutating, 183
- Brush gear for bipolar machines, 181; multipolar machines, 181
- Brush-holders : collection of dust on insulation, and faults resulting from, 365; conditions they must conform to, 184
- Bucket pump, description of, 296
- Bulkhead fitting for incandescent lamps for use underground, 75
- Burning out of armature coils, *rationale* of, 361
- C
- Cables for coal-cutting machines and moving motors, construction of, 229
- Callender's bitumen cables, construction of, 218
- Calorific values of different coals, 101
- Campbell Gas Co.'s oil engine, description of, 164
- Campbell oil-engine governor, 165
- Campbell suction gas producer, 156
- Capacity of cables, 17
- Capel fan, description of, 337
- Carbon brushes : density of current with, 183; for continuous-current machines, 182
- Carbon filament : behaviour of, when current passes, 72; disintegrating action in, with current, 72
- Cathode, 2
- Causes of failure, general notes on, 350
- Centiampère : meter for general road-signals, 32; use of, in testing, 354
- Central condensing stations, 141

- Centrifugal fan, description of, 337
 Centrifugal governor, description of, 126
 Centrifugal pump: arranged in series, 291; arranged for sinking with electric motor, 292; best output with constant speed, 291; best speed for efficiency, 290; conversion of velocity head into pressure head, 288; description of, 287; efficiency of, 287; forms now made, 288; modern construction to avoid eddies, 288
 Chain coal-cutting machines, description and operation of, 326
 Charge made by cables for converting energy, 209; on pressure, 210
 Chimney, replaced by fan, 105; the use of, 104
 Choking coils and compensators for alternating-current arc lamps, 63
 Chopper switches, description of, 265
 Circuit breakers: construction of, 268; use of, 268
 Classification of engine by expansion, 120
 Climax water-tube boiler, description of, 96
 Closed circuit, 6
 Coal conveyers: the bucket, the belt, and the archimedian screw, 118; general arrangement of, 118
 Coal cutting by electricity, 324; with drilling machines, working of, 335
 Coal-dust burning engine, description of, 168
 Coke-oven gas: calorific value of, 153; production of, 153; quantity required per H.P. per hour, 155
 Combustion: explanation of, 98; of coal, heat liberated by, 98; of petroleum, heat liberated by, 98
 Commutator insulating rings, form and construction of, 175
 Comparison of volt: with pressure of Leclanché cell, 5; with pressure of Standard Clark cell, 5
 Compensator enables alternating-current arcs to be extinguished without loss, 65
 Compound engine, description of, 121
 Compound and triple-expansion engines, work done by, 122
 Compound, triple, and quadruple engines, division of work in, 124
 Compound-wound continuous-current generator: description of, 180; compounding up, explanation of, 181
 Compound-wound motor, forms of, 275
 Compressed air: inefficient use of, in motor engine, 343; loss by heat generated, 342; losses in transmission of, 341; moisture present in, 343; plant, description of, 342; plant driven by electric motor, description of, 344
 Concentric cables: description of, 221; with uninsulated outers, 223
 Condensers: advantages of, 134; cooling water required with, 138; ejector, Ledward, 138; evaporative, Ledward, 136; forms of, 135; general description of, 135; jet and ejector, disadvantages of, 139; jet, Worthington, 137; surface, difficulties with, 139; when not economical, 135
 Conditions for small sparking at commutator, 184
 Conductivity and insulating tests in dynamos, 362
 Conductors for electric light and power distribution, 211
 Conductors and insulators, 5; use of old wire ropes for, 211
 Connecting engine-road signal-wires at junctions, 31
 Connecting separately excited machines to bus bars, 247
 Connecting shunt-wound machines to bus bars, 247
 Connections of coils in ring and early drum armatures, 173
 Conservation of energy, 3
 Contact supports for arc lamps: reason for use of, 66; general description, 66
 Continuous-current armatures, insulation of conductors, 171
 Continuous-current commutator, construction of, 174; difficulties in insulating, 174
 Continuous current, definition of, 14
 Continuous-current generators, 169; the armature, construction of, 170
 Continuous-current machines: with commutating poles, description of, 185; with two armature windings, 200
 Continuous-current motor, description of, 272
 Converter equalizer electric winding apparatus, 317
 Conveyers for ashes, 119
 Cooling apparatus, difficulties met with in working of, 151
 Cooling stationary transformers, 205
 Cooling towers, operation of, 147
 Cooling towers and ponds, reasons for employment of, 146
 Cooling transformers, use of cold storage plant, 206
 Copper brushes: density of current with, 183; use of, 183
 Copper losses in stationary transformers, 204
 Core transformer, description of, 202

Cornish boiler, 89
 Corpuscular theory: of electric current, 2; of light, 2
 Crook's tubes, 2
 Current for mining signals from power and lighting service, 27
 Curtis turbine, description of, 144
 Cyclone method of burning coal dust, 107
 Cylinder condensation discussed, 127; in compound and triple expansion engines, 127; methods of overcoming, 128

D

Dashpots, employment of, in arc lamps, 58
 Definition of: the ampère, 6; B. Th. Unit, 9; lines of force, 12; magnetic reluctance, 13; magnetic resistance, 13; the Ohm, 5; specific heat, 9; two-phase currents, 16; the volt, 5; the watt, 9
 De Laval turbine, description of, 143
 Delivering alternating current to arc lamps, general arrangement for 100 to 500 volt services, 60
 Delivering current to arc lamps, 59; to coal-cutting machines, 329; to incandescent and Nernst lamps, general instructions, 79
 Denver Engineering Co's. electric air drill, 332
 Dialite, advantages claimed for, 218
 "Dialite" bitumen cables, construction of, 218
 "Diatrine" insulation, description of, 219
 Diesel engine: control of the fuel supply, 168; description and operation of, 166; government of, 168
 Difference in the working of continuous and alternating current arc lamps, 61
 Different forms of lamp-holders, descriptions of, 73
 Difficulties of working expansively, 126
 Direction of lines of force, 12; in the dynamo machine, 12
 Disc alternator: connection of coils in, 186; the exciter for, arrangement of, 187; disc coal-cutting machines, description and operation of, 326
 Disconnections in continuous-current armatures, 358
 Distribution by two- and three-phase currents, 241; at high tension, 243; at extra high tension, 244
 Distribution of light with alternating

and continuous current arc lamps, 54; of power by electricity, 209
 Double-carbon arc lamps, general description and working of, 52
 Double-pole switches, 264
 Draught: by steam jet, operation of, 105; explanation of, 104
 Drilling by electricity, 330
 Driving air compressors, 341
 Drum-armature alternator, connections of, 188
 Dry cell, description of, 29
 Dynamo machine, general arrangement of, 11
 Dynamotor, description of, 198

E

Early drum armature, description of, 172
 Early Siemens armature, 172
 Economizers, 113; Carter's, 114; cleaning the outside of tubes of, 114; deposit of soot on the outside of, 114; driving the scrapers for, 114; Green, 114
 Edison secondary battery, description of, 194
 Edwards' air pump for condensers, description of, 135
 Effective ampères, 15
 Effective volts, 15
 Effect of heat upon resistance of cables, 227
 Efficiency and life of incandescent lamps, 71
 Electric air percussion drills, 332
 Electric circuit: definition of, 6; measurement of the power in, 209
 Electric condenser return current, time interval with main current, 18
 Electric drilling machine, forms of, 332
 Electric driving of: bucket pumps, 297; other machinery about a mine, 347; overhead rope railways, 309
 Electric fuses for shot firing, 41; connecting in parallel, 43; connecting in series, 43; high tension, description of, 41; high tension, pressure required for, 42; low tension, battery for, 41; low tension, current taken by, 41; low tension, description of, 41; magneto-exploder for, description of, 42
 Electric ignition for gas and oil engines: with battery, 166; with magneto-generator, 166
 Electric locomotives, 346
 Electric locomotive: for use on the surface, 347; on overhead rope railway, 309; trolleys employed with, 347

- Electric mining signals, forms used, 22
 Electric motor, forms of, 272
 Electric motors: advantages of, for isolated positions over steam, 348; must not be started too quickly, 277; and their switchboards, 348
 Electric percussion drills, 332
 Electric rotary drilling machines, 332
 Electric storage battery locomotive, 346
 Electrical condenser, 18
 Electrical current, 4
 Electrical pressure, 4; by contact, 10; from electrostatic return current, 18
 Electrical pressures set up between copper and lead, 10; between iron and copper, 10.
 Electrically driven coal conveyers, 348
 Electrically driven dip pumps, 287
 Electrically driven fans *v.* steam-driven, 340; place for, 340
 Electrically driven pumps, 286; at Tralfalgar Colliery, 286
 Electrically driven sinking pumps, 287
 Electrically driven and steam driven compressed air compared, 344
 Electrolysis: the anode, 20; the cathode, 21; effect upon rails, ropes, pulleys, etc., 21; in the Leclanché battery, 21; in the secondary battery, 21; with leakage currents, 21
 Electro-magnetic induction, 19; with alternating current, 19; with coils, 19; with continuous current, 19; with straight cable, 19
 Electrons, 2
 Electrostatic capacity: effect of decrease of pressure, 18; effect of increase of pressure, 18; of long cables, 18
 Electrostatic capacity and leakage currents in three-phase services, 17
 Electrostatic charge, explanation of, 17
 Electrostatic induction, explanation of, 17
 Electrostatic return current to the cable, 18
 Electrostatic voltmeter
 262
 Electrotonic theory, 1
 Enclosed arc, 45
 Enclosed arc lamp: forms in which carbon burns, 46; general description and working of, 51
 Enclosed fuses, description of, 267
 Enclosed iron switches for underground, 258
 Endless rope haulage, description of, 300
 Energy of coal, methods of employing, 88
 Engine-road indicator signal, description of, 24
 Engine-road signal, description of: with bell at each end of road, 23; with one bell, 22; with two bells, 23
 Engine-road signals, and cables for lighting and power service, important note respecting, 33
 Engine-road signals, wire employed, 30
 Engine-road signal wires: not to touch cables, 33; termination of, 31
 Engine-road signal with bells at several stations, connected in parallel, 24; connected in series, 24
 Equalizing bar, use of, in paralleling, 251
 Estimating power of steam and compressed air engines, 348
 Ether, 2
 "Excello" flame arc lamp, 55; carbons employed in, 55; comparison of light given with ordinary arc lamp, 57
 Excitation of continuous-current machines, 175
 Expansion governor, description of, 126
- F
- Failure by lowering of insulation resistance, 350
 Failure by resistance in conductive path, 350
 Fall of pressure in cables, 210, 224
 Faults: in armoured cables from falls of mineral, 368; in cables, 366; in dynamo machines, general notes on, 357; in mine signals, 352; in mining bells, 354; in switch gear, 371; in telephones, 355
 Feed-water heaters: general description of, 114; Royle's, 115
 Ferranti alternating current time-limit relay for circuit breakers, description of, 269
 Finding a short circuit between cables, 368
 Fireproof covering for cables: description of, 220; reason for use of, 220
 Firing shots by electricity, 41; operation of, 42; precautions with, 42
 Fitting up engine-road signals, 30
 Fittings for high C.P. incandescent lamps, 76
 Five-wire system, explanation of, 239
 Fixing cables: in mines, 229; in shafts, 230; on engine roads in wood boxes, 234
 Fixing wires on engine roads, methods of, 234
 Flame arc lamps: the carbons employed,

54; colour of the light, how produced, 54; general description, 54; spreading of flame by electro-magnet, 55
 Flues of steam boilers, use of, 89
 Forced draught: by steam jet, 105; explanation of, 105
 Formation of smoke, explanation of, 102
 Formation of stranded conductors, explanation of, 221
 Forms in which Ohm's law may be written, 4
 Forms: of fans, description of, 336; of galvanic battery, 28; of pumps, 287; of starting gear for motors, 276
 Formula: for current passing in main circuit, 6; for heat liberated by electric currents, 9; for heat liberated in cables, 226; for measurement of work in alternating currents, 9; for rate of doing work, 9
 Four-phase currents, 17
 Friction of water in pipes, equivalent head for, 298
 Frictional electric firing apparatus: difficulties in the use of, 44; general description of, 43
 Furnaces of steam boilers, description of, 89
 Fuses: construction of, 266; enclosed in iron cases for mining work, 268; the use of, 266

G

Gas detector for portable electric lamps: H. J. Prested's apparatus, 82; Sussmann form of, 82
 Gas engine working with suction producer gas, description of, 155
 Gas engines: combustion of gas in, 158; for large powers, 161; ignition of explosive mixture, 158
 Gas and oil engines, arrangement of water jacket and water reservoirs, 160; cooling the cylinders of, 160; the government of, 159
 Gate road connecting boxes, construction of, 259
 Gem carbon filament incandescent lamp, description of, 70
 Generating station, size of units, 207; units in, 206
 Generation of electricity by water power, 83; forms of power that can be employed, 83
 Generators of electricity: forms of, 169; principles upon which all are constructed, 169

Government of compound and triple-expansion engines, 124; steam engines, methods of, 126
 Gramme armature, 172
 Gravity machinery instruments, description of, 261
 Grease extractors, necessity for and general description of, 117
 Guards for overhead conductors, 215
 Gutmuth valve for ram pumps, description of, 293
 Gutta percha for insulating cables, objections to, 216

H

Haulage arrangement for Longwall coal-cutting machines, 327
 Heading machines: description of, 327; operation of, 328
 Heat: delivery of, to water in a steam boiler, 99; is one form of work, 9; liberated by combination of carbon and oxygen, 101; liberated by electric currents, 9; loss of, due to hot gases in motive column, 105; loss of, from presence of nitrogen in air, 101; loss of, when furnace doors are open, 103; unit, 9
 Heating effect on short circuit, 227
 Heating of cables, 226
 Heavy cables, makers' lengths of, 221
 High C.P. incandescent lamps: forms made, efficiencies of, 71; general description, 71
 High efficiency lamps, when it is cheaper to burn, 71
 High pressure insulators, resistance to sparking of, 213
 High tension cell switches, description of, 253
 High tension insulators, supporting bolts of, 214
 High tension oil immersed switches, description of, 253
 Hit-and-miss governor, 159
 Holders and fittings for incandescent lamps, 72
 Holders for high C.P. incandescent lamps, 76
 Holing or kirving, description of, 324
 Hornsby oil engine: description of, 163; governor, 165
 Hornsby water-tube boiler, description of, 94
 Hot wire measuring instruments, description of, 261

I

Ignition by electric spark in gas and oil engines, description of, 166
 Ignition of explosive atmospheres from trembler bells, 35
 Impressed pressure; how calculated, 20; in inductive circuits, 20
 Incandescent lamps: B.C. lamp, 68; carbon filament, the light given by, 69; carbon filaments, pressures made for, 69; carbon filaments, sizes made, 69; C.C. lamp, 68; connecting in series, objections to, 80; current taken by, at different pressures and efficiencies, 69; economy of burning under power, 72; efficiency of, 69; forms employed in mines, 68; low pressure and high pressure compared, 69; vitrite cap, 68; winking in with alternating currents, 70; with carbon filament, high C.P., 70; with carbon filament, low C.P., 70; with metallic filament, 70
 Incandescent metallic filament lamps, 70.
 Increase of temperature in a cable, 10
 Independent distribution system: advantages of, 252; disadvantages of, 252; working of, 251
 Indiarubber for insulating conductors, 216; objections to the use of, 217; Para v. W. African, 217
 Induced draught: difficulties in arrangement of, 105; explanation of, 105
 Inductive pressure at right angles to service pressure, 19
 Inductor alternator, description of, 192
 Infra red rays, 3
 Injector: boiler pressure it will feed against, 113; Holden & Brooke's, 113; use of, with exhaust steam, 113
 Insulated conductors, 215; substances employed for, 215
 Insulating substances for cables, composition of, 216
 Insulators: for engine-road signals, 30; for overhead conductors, 213; substances forming, 5
 Intercommunication telephone apparatus: description of, 38; operation of, 39; wires for, 39
 Internal combustion engine, general description of, 157
 Iron boxes for enclosing switches for underground, 258
 Iron losses in stationary transformers, 204
 Iron nickel battery, 193

Iron poles for overhead conductors, 215
 Isolated engines, displacement of, by electric motors, 348

J

Jandus arc lamp, 51
 Johnson & Phillips' enclosed arc lamp, description of, 52
 Jointing shaft cables, 234
 "Juno" flame arc lamp, description of, 56

K

Kinds of lamps in use in mines, 45
 Knife-blade switches, construction of, 263
 Körting cooling pond with nozzle, 151
 Körting gas engine: description of, 161; quantity of gas consumed by, 162

L

Lag of current behind pressure, 19
 Lahmeyer Co.'s arrangement of three-phase motor for main and tail haulage, 306
 Lamp-holder for small incandescent lamps, description of, 72
 Lancashire steam boiler, 88; Messrs. Galloway's modification, 89
 Large gas engines with two Otto cylinders in tandem, 161
 Latent heat: explanation of, 100; of steam, 100; of water, 100
 Law of electrostatic capacity, 17
 Lead lead-oxide battery, description and operation of, 193
 Leakage circuits, 6
 Leakage current shown by centiampère meter, 32
 Leclanché battery, open type, description of, 28
 Leclanché cells, hints on recuperating, 352
 Length of waves: in red rays, 2; in violet rays, 2
 Lighting service from three-phase power service, 243
 Lineman's galvanometer, description of, 352
 Liquid resistance: for starting gear, 276; for varying speed of series motor, disadvantages of, 283
 "Locked coil" armour for cables, 219

Longwall coal-cutting machines, description of, 325; operation of, 326; speed of, 327
 Longwall system of coal working, 325
 Longwall system of coal cutting, 324
 Lord Kelvin's law: of loss in cables, 225; applied to cheap sources of current, 225
 Loss in cables generally allowed, 225
 Low efficiency lamps, when it is cheaper to burn, 72
 Lower carbon-holder of arc lamps, arrangement of, 52
 Luna arc lamp, description of, 49
 Luna shunt arc lamp, working of, 49

M

Magnets, attractions and repulsions of poles of, 12
 Magnetic circuit: of the dynamo machine, 13; of electric bells, 14; law of the resistance of, 14
 Magnetic flux, density, and ampère turns, 13
 Magnetic lines of force, 12
 Magnetic permeability of bismuth, 13
 Magnetic permeability of Swedish iron and special magnetic steel, 13
 Magnetic reluctance, 13
 Magnetic reluctance of air and insulating material, 13
 Magnetic reluctance of iron and steel, 13
 Magnetic resistance, 13
 Magnetism and ampère turns, 13
 Magnetism: arrangement of wire coils for creating, by electric currents, 13; excitation of, in iron, 13
 Magneto-electric induction, law of, 11
 Magneto-exploder, operation of, 42
 Magneto-motive of force, definition of, 13
 Main switchboard: general description of, 245; panels of, 245; instruments of each panel, 245
 Main switches: current density in, 263; general construction of, 262
 Main and tail haulage, description of, 306
 Marine boiler, 89; Messrs. Davey & Paxman's modification for land use, 89
 Marvin electric percussion drill, description of, 333
 Mavor & Coulson's concentric cables, 223; junction boxes for, 223
 Mavor & Coulson's fuse distribution boxes for their concentric cables, 259
 Meaning of the term "pressure," 4
 Measurement of work: in alternating currents, 9; in electric circuits, 8; pressure employed in, 9
 Measuring instruments for main and sub-station switchboards, 259
 Mechanical stokers: Babcock chain, description of, 104; description of, 104; forms of, 103
 Mechanism of arc lamps, 47; the Brockie-Pell brake, 47
 Mercury bichromate cell, 29
 Mercury bichromate cells, hints on recuperating, 353
 Methods of burning low-grade fuels, 106
 Methods of burning very fine coal-dust, 107
 Methods of distribution of electricity, 235
 Methods of producing electrical pressure, 10
 Methods of varying speed of electric motors, 282
 Micanite, the use of, in commutators, 174; description of, 175
 Mining electric locomotives, description of, 346; operation of, 346
 Modern drum armature, construction of, 173
 Molecular magnets, behaviour of, in Ewing's theory, 12
 Molecular theory, 1
 Molecule, the, 1
 Mond gas: calorific value of, 154; description of, 153
 Motive column, explanation of, 104, 340
 Motors: best for driving centrifugal pumps, 292; best form for driving endless rope haulage, 305; best forms for main and tail haulage, 306; for coal-cutting machines, 329; for driving fans, 339 for driving ram pumps, 295
 Motor with commutating poles, 285
 Motor generator for supplying current for arc lamps, advantages of, 60
 Motor generators: description of, 198; generators with two- and three-phase currents, 199
 Moving coil measuring instruments, description of, 260
 Multiple-cylinder engines, reason for, 121
 Multiple magnetic circuits, 14; in dynamo-machines, 14
 Multipolar continuous-current generators, description of, 172

N

- National Gas Co.'s oil engine, description of, 164
 Natural induced and forced draught, 104
 Negatively electrified corpuscles, 2
 Nernst lamp: compensating resistance in, description of, 78; and reason for use of, 78; connections of, 78; distribution of light with different globes, 79; efficiency of, 79; general description of, 76; the "glower," description of, 76; operation of, 77; time taken in heating, 78; the heating coil, 78; precautions in connecting, 79
 "Nicking" with electric drilling machines, 335
 Niclausse water-tube boiler, description of, 96

O

- Oechelhausen gas engine, description of, 161
 Ohm, the, 5
 Ohm's law: of electric current, 4; with opposing pressures, 4
 Oil-cooled transformers, 206
 Oil engine and the petrol engine, 163
 Oil engine, spraying apparatus for, 163
 Oil-engine governors and gas-engine governors, 165
 Oil engines: different methods of vaporizing, 163; explained, 163; ignition by electric spark, disadvantages of, 166; ignition problem, 165; use of water jet with, 164, vaporizers for, 163
 Oil filters, 117; Wells', 117
 Old wire ropes, objections to the use of, 211
 One ohm, lengths of copper wires in, 5
 Open arc, 45
 Open-arc lamp, forms in which carbons burn, 46
 Open circuit, 6
 Operating board for high tension switches, 253
 Osram lamp, efficiency and sizes made, 71
 Otto cycle, description of, 157
 Output of alternators, 191
 Overhead conductors, 212; limiting sizes of, 212; solid or stranded, 212
 Overhead rope railways, description of, 309

P

- Paper-covered cables with bitumen tubes, 219
 Paper- and yarn-covered cables: advantages of, 219; construction of, 219; insulation of, 219; lead tube, use of, 219; protection from moisture, 220
 Parallel circuits, definition of, 8
 Parallel or bus-bar system, description of, 246
 Parallel-series circuits, definition of, 8
 Paralleling compound continuous-current machines, explanation of, 250
 Parsons apparatus for high vacua, 146
 Parsons steam turbine, government of, 142
 Path for electric current inside the battery, 10
 Pelton water-wheel, description of, 88
 Poles for supporting insulators, 215
 Portable accumulator electric lamps, charging from motor generator, 81
 Portable electric lamps, 80; Sir Joseph Swan's accumulator lamp, 81; the Sussmann accumulator lamp, 81; the Sussmann accumulator lamp, charging, 81; with flexible cables, 81
 Positively electrified corpuscles, 2
 Power factor, proportional to cos. of angle of lag., 20; usual standard taken, 226
 Power for lifting trams and minerals, 303
 Power in motor for single drum haulage, 305
 Power required: for driving air compressors, 345; for endless rope haulage, 302; and calculation for, 303; for fans, explanation of, 340; for lifting water, 297; for main and tail haulage, calculation of, 307; for moving air, calculation of, 340; for overcoming friction, caution in applying rule, 299; for overcoming friction of waggons, 303; for overcoming the friction of water in pipes, 298; for single drum haulage, calculation for, 305; in motors driving pumps, calculation for, 299; in motor for driving endless rope haulage, 304; in motor for driving fans, 341; in motor for three-phase haulage, 308
 Pressure: employed with three-phase currents, 243; of machines at the bus bars, 248; and control of, 248; variation of, with current, 248; produced by belt rubbing a pulley, 10; by chemical action, 10; by friction of steam, 10; produced in thunder clouds, 10; required

for electrolysis, 11; to be employed in Ohm's law, 6
 Primary galvanic batteries, 10
 Producer and blast furnace gas, quantity required for B.H.P. per hour, 155
 Producer and kindred gas, 152
 Producer gas: calorific value of, 153; description of, 153
 Prof. Ewing's theory of magnetism, 11
 Prof. Kapp's measurements of magnetic reluctance, 13
 Propeller fan, description of, 337
 Properties: of the ether, 2; of magnets, 12; of red rays, 2; of violet rays, 2; of yellow rays, 2
 Protection: from shock with overhead conductors, 215; from mischief of overhead conductors, 215
 Pushers for shaft signals, description of, 34

Q

Quadruple-expansion engine, description of, 121
 Quadruple-pole switches, 264
 Quantity represented by H., 13; by B., 13
 Quick starting of motors, reasons against, 278

R

Rainbow, 2
 Ram pumps: description of, 292; speed of, 292; with Gutermuth valves, 295; with variable stroke, 296
 Rateau turbine, arrangement of, with thermal storage, 145
 Rate of doing work in electric circuits, 8
 Reciprocating steam engines, 119; high speed and low speed, distinction between, 119
 Recuperating cells by aid of current, objections to, 353
 Relays for mining signals, description of, 36; reason for use of, with mining signals, 36
 Researches of Hertz, 3
 Resistance: application of the laws to the insulation of cables, 5; explanation of, 5; for varying speed of series motor, caution about, 283; the laws of, in any substance, 5; variation of, with temperature, 5; with continuous-current arc lamps, how calculated, 62
 Reversible booster: description of, 197; efficiency of, 197

Revolving field alternator: description of, 188; exciter for, 189
 Riedler ram pump: description of, 293; speed of, 293, efficiency of, 293
 Ring continuous-current armature, description of, 172
 Ringing keys for shaft signals, description of, 34
 Rotary convertor: description of, 199; ratios of conversion from continuous to alternating currents, 199
 Rotary converters in sub-stations, 200
 Rotary heading machine: description of, 328; operation of, 328
 Rubber insulators for engine-road signals, 30
 Rules for testing, 351

S

Schwartzkopff method of burning coal-dust, 108
 Scrubber for suction producer gas, 154
 Secondary batteries, 193; employment of, in generating stations, 196; forms of, on the market, 193; leakage from, 195; precautions in using, 196; pressures of, 195; rated discharge of, 195; usual arrangement of, 195
 Self-excitation of continuous-current machines, explanation of, 175
 Self-exciting continuous-current machines, 175
 Self-government of motors, explanation of, 275
 Separately excited continuous-current machines, 176
 Series circuit, definition of, 7
 Series, connection of battery cells in, 7
 Series and parallel circuits, 7
 Series-wound continuous-current machines: description of, 177; use of, 177
 Series-wound motor: properties of, 272; and the ram pump, 295
 Shackle insulators for terminating engine-road signal wires, 31
 Shades and guards for incandescent lamps underground, 75
 Shaft cables: fixing by cleats, 231; fixing in boxing, 232; fixing in iron pipes, 233; fixing on insulators, 231
 Shafts of metalliferous mines, description of, 322
 Shaft signals: general description of, 33; wires employed with, 33; with one or two batteries, 33; worked from motor generators, 35
 Shell transformer, 202

- Shot-firing by electricity, general description of, 41
- Shunt-wound continuous-current generator, with low armature resistance, 180; variation of pressure, with varying external current, 179; with variable field current, 179
- Shunt-wound continuous-current machine, description of, 178
- Shunt-wound motor: for main and tail haulage, 306; properties of, 273; and the ram pump, 295; self-governing, 275
- Siemens' electric rotary drill, 332
- Siemens-Ilgner apparatus, use of fly wheel in, 315
- Siemens-Ilgner electric winding apparatus, description of, 314
- Simple alternating current, 16
- Simple engine, 120; work done by, working expansively, 122; working non-expansively, 122
- Single and double break switches, 264
- Single and double throw switches, 265
- Single-phase current, 16
- Single-pole switches, 263
- Single, two- and three-phase transformers, description of, 205
- Sir Isaac Newton's theory of light, 2
- Sirocco fan, description of, 338
- Six-phase currents, time interval, 17
- Sizes of cables: allowing for power factor, 226; factors controlling, 224; formula for calculating, 225
- Sizes of three-phase cables, formula for calculating, 226; two-phase cable, 226
- Slowly revolving engines with Corliss valves, 120
- Sound waves, 2
- Sources of current for mining signals, 27
- Special magnet steel, magnetic reluctance of, 13
- Specific heat, 9; of air, 100; of metals, 10; of nitrogen, 101
- Specific inductive capacity defined, 17; of impregnated paper, 17; of india-rubber, 17
- Specific resistance: definition of, 5; of insulators, 5; of iron and steel, compared with silver and copper, 5
- Spectrum, 2
- Spur-gearing for haulage gear, 308
- Squirrel-cage rotor for three-phase motor, description of, 279
- Standard unit of resistance, 5
- Starting electric motors, care in, 277
- Starting-gear for electric motors, reason for, 275
- Starting-gear for motors for coal-cutting machines, 329
- Starting three-phase motors, 279; reasons for reducing current, 280
- Stationary transformers: losses in, 204; operation of, 202; and power factor, 203; proportion between iron and copper losses, 204; self-regulation with output, 203; use of, 200
- Steam boilers, forms of, 88
- Steam jacketing cylinders, 128
- Steam turbines, 141; and condensing, 146; the Parsons, admission of steam to, 142; the Parsons, general description of, 141
- Step-down transformers, 202
- Step-up transformers, 202
- Stirling water-tube boiler, description of, 92
- Stopping at different levels in metalliferous mine shafts, 322
- Stranded overhead conductors, disadvantages of, 213
- Sub-station switchboard: description of, 254; for current from power station, 254; for distributing points in-by, 254; for pit bottom, 254
- Suction gas producer: fuel consumed per B.H.P., 155; water required with, 155; advantages claimed for, 155
- Superheated steam, advantages of different degrees of, 133; thermal conductivity of, 133
- Superheater: Davey & Paxman's, 131; Tinker's, 130
- Superheaters, forms of, 129
- Superheating, advantages of, 131; difficulties in the way of, 132; general description of, 129; quantity of heat required for, discussed, 130
- Supplying lamps from a machine compounding up, 181
- Supporting arc lamps, general arrangement, 65
- Supporting bolts of insulators, iron or steel *v.* wood, 214
- Supports and protection for lamps in mines, 74
- Switchboard gear for high tensions and extra high tensions, explanation of, 253
- Switches for use underground, 258
- Switches: fuses and circuit breakers, 262; with carbon break, description of, 265
- Synchronizers, description of, 250
- Synchronizing apparatus, necessity for, 249; with lamps, description of, 249
- Synchronizing panel, 246
- Synchrosopes, description of, 250
- Systems of coal working, 325

T

- Tantalum lamp, description of, 70; efficiency and life of, 71
- Telegraph wireless straining vice, description of, 31
- Telephone exchanges: batteries for, 38; for mining work, operation of, 38
- Telephones for mines, general arrangement of, 37
- Telephonic communication on engine roads: microphone apparatus for use on engine roads, 40; operation of 40
- Temperature that may be reached in a cable on short circuit, 228
- Testing by electrostatic capacity of cables, 370
- Testing cables for disconnection, 369
- Testing for conductive resistance, 367
- Testing for disconnection: in alternating-current armature, 361; in continuous-current armature, 359; in field coils, 363; in mining signals, 354; in telephones, 356; in three-phase currents, 362; in two-phase armatures, 362
- Testing for insulation of armoured cables, 366; insulation of continuous-current armature, 364; insulation of unarmoured cables, 367; leakage in mining signals, 355
- Testing switches, apparatus used for, 371
- Testing with low-reading volt meters and dry cells, 352
- Theories of electricity, 1
- Thermal insulation of steam cylinders discussed, 128
- Thermo-electric apparatus, use of construction of, 11
- Thermo electricity, law of, 11
- Thornycroft water-tube boiler, description of, 95
- Three-core cables: description of, 224; reason for use of, 224
- Three-phase alternators: mesh connection, 190; star connection, 190
- Three-phase currents, 16
- Three-phase machine: difference in pressures and currents with mesh and star connection, 192; measurement of output of, 198
- Three-phase motor compared with shunt motor, 280; description of, 278
- Three-phase motor: for main and tail haulage, 306; objections to, for driving fan, 339; operation of, 280; revolving field in, 280
- Three-phase motors for coal-cutting machines, advantages and disadvantages of, 330
- Three-wire system, explanation of, 238; with electrically driven balancer, 240; with one generator, 239; with steam-driven balancer, 240; with two generators, 239
- Throttle and expansion governors compared, 126
- Throttle governor, description of, 126
- Tightening engine-road signals wires, 31
- Time-limit circuit breakers: construction of, 269; forms of, 269; reason for, 269
- Trafalgar Colliery electric pumping plant, description of, 286
- Transmitting power from electric motor to haulage gear, 308
- Triple concentric cables, description of, 223
- Triple-expansion engine, description of, 121
- Triple-petticoat insulators, 213
- Triple-pole switches, 264
- Trouble with brush-holders, general notes on, 365
- Troubles with ring and early drum armatures, 173
- Turbines using exhaust steam, 145
- Turning up commutators, faults caused by, 361; the best plan to adopt, 361; precautions in, 360
- Twin arc lamps, description and employment of, 53
- Two-cycle gas engine, operation of, 161
- Two-phase cables, construction of, 224
- Two-phase currents, 16; explained, 16
- Two-phase machine, measurement of output of, 191
- Two- and three-phase alternators: connections of, with drum armature, 190; description of, 189
- Two- and three-phase circuits, 16
- Two- and three-phase machines, proportion of output as compared with single phase, 192
- Two-wire system, explanation and use of, 236, 238

V

- Values of power factors, 20
- Variation in effect of heat upon resistance of conductors, 227
- Variation in magnetic reluctance of different bodies, 13
- Variation of pressure: at ends of cables, 210; in cables, effect on lamps, 211
- Variation of speed of fan, 339
- Varying speed of series motor: by shunting field coils, 284; by varying pressure, 283

- Varying speed of shunt-motor by varying field current, 284; by varying field currents, limits of, 285; by varying field current with sparking, 285; with commutating poles, 285
- Varying speed of three-phase motor, 286
- Ventilation compared with electric distribution, 339
- Virtual or effective currents, use of, 15
- Virtual or effective pressures, use of, 13; definition of, 15
- Virtual or effective currents, definition of, 15
- Volt, the, 5
- Volt-meters and ampère meters, different forms of, 259
- Vulcanized rubber insulated cables, construction of, 216
- W
- Water-cooled transformers, 206; energy delivered by, 85
- Water-power: the cost of, 84; conditions necessary for the use of, 84; when it is economical, 84; measurement of, 85
- Water softeners: general description of, 116; reason for, 116; Royle's, 116
- Water-tube boilers, forms of, 91
- Water-turbines, description of, 87
- Water-wheels, description of, 87
- Watt, the, 9
- Watts in 1 H.P., 9
- Wave theory, 1
- Westinghouse drum armature alternator, 187
- Westinghouse Co.'s high-tension oil-immersed switch, 253
- Westinghouse Steam Turbines, description of, 145
- Westinghouse system of electric winding, description of, 317
- Whiting system of winding for metalliferous mines, 323
- Willans' engine, 120
- Willans-Parsons steam turbine, description of, 142
- Willis' engine road-indicator signal, description of, 24
- Winding by electricity, 309; the Lahmeyer Co.'s arrangement, description of, 313
- Winding of continuous-current armature coils, 172
- Winding-problem discussed, 310
- Winding: sources of waste in, 310; power required at starting, 311; power required for acceleration, 311; power stored in descending cage, 311; in stable-pits, 312; by shunt- and series-wound motors, directly connected, 312; in metalliferous mines, 322; by three-phase motors, directly connected, 312; waste with directly connected motors, 312; variation of pressure with directly connected motors, 313; variation of pressure at Preussen II Colliery, 313
- Wireless telegraphy, 3; unsuitable for mines, 40
- Wires and cables for connecting to lamps, 228; protection of, 228
- Wirt Co.'s copper-brush, 182
- Work done in electric circuits, 8
- Working steam-engines expansively, 120
- Working units to full power, 208
- Worm gearing for haulage gear, 308
- Wound-rotor for three-phase motor, 279

THE END

PRINTED BY
WILLIAM CLOWES AND SONS, LIMITED,
LONDON AND BECCLES.

6

UNIVERSITY OF CALIFORNIA LIBRARY
BERKELEY

**THIS BOOK IS DUE ON THE LAST DATE
STAMPED BELOW**

Books not returned on time are subject to a fine of 50c per volume after the third day overdue, increasing to \$1.00 per volume after the sixth day. Books not in demand may be renewed if application is made before expiration of loan period.

OCT 22 1919.

FEB 7 1942

Walker
u. Es. u. 1 L

TN 343
W 2

302939

Walker

UNIVERSITY OF CALIFORNIA LIBRARY

