

UC-NRLF

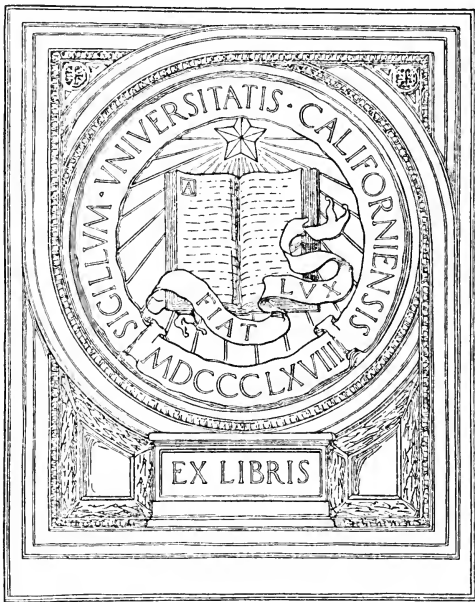

B 4 059 041

MEDICAL SCHOOL
LIBRARY



COLLEGE OF PHARMACY

Book Department
TECHNICAL AND SCIENTIFIC PRESS
420 MARKET STREET
SAN FRANCISCO
Catalogue of Technical Books on request

Digitized by the Internet Archive
in 2007 with funding from
Microsoft Corporation





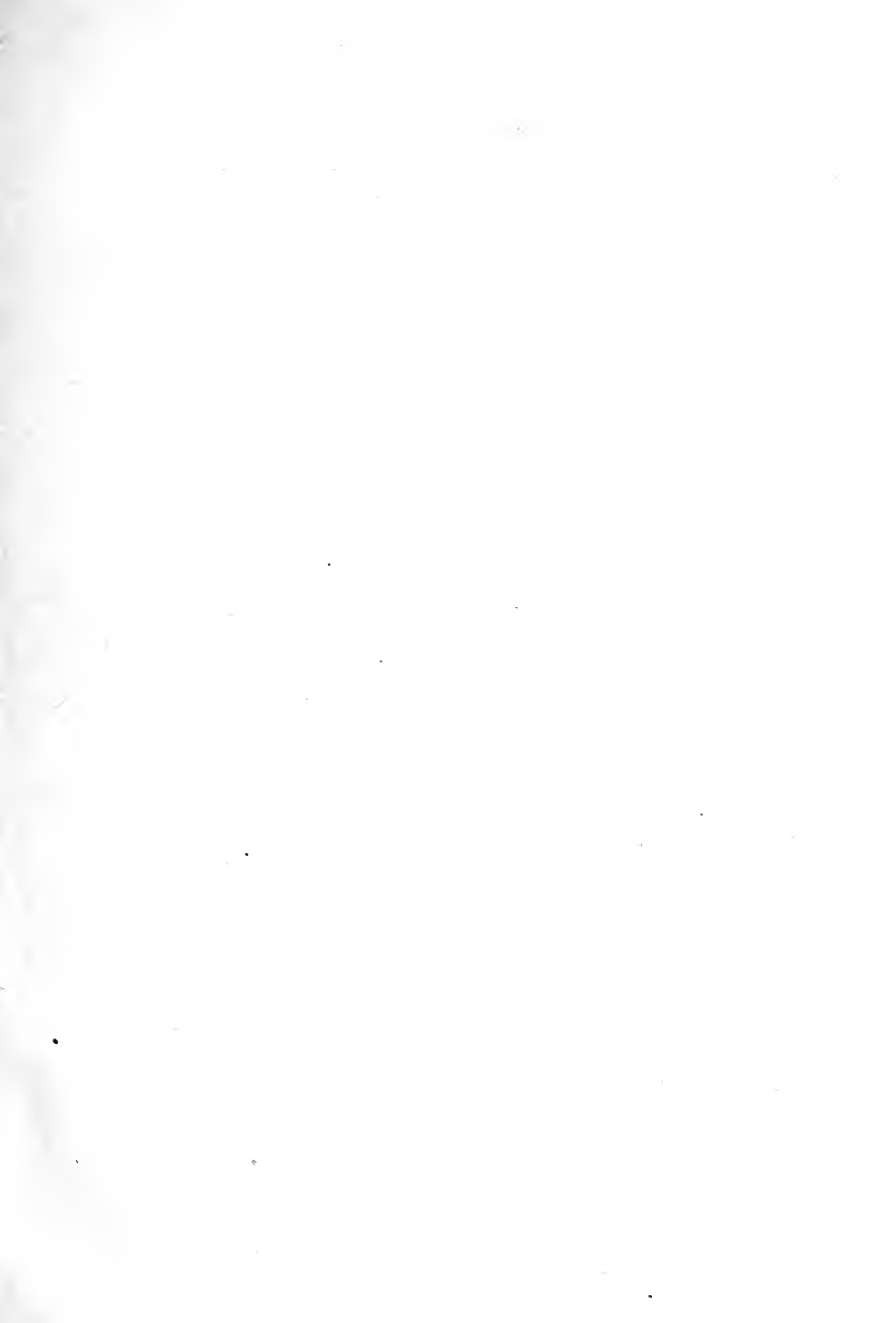

ELECTRO-ANALYSIS

SMITH



ELECTRO-ANALYSIS

BY

EDGAR F. SMITH

BLANCHARD PROFESSOR OF CHEMISTRY, UNIVERSITY OF PENNSYLVANIA

FIFTH EDITION, REVISED AND ENLARGED

WITH FORTY-SIX ILLUSTRATIONS

PHILADELPHIA

P. BLAKISTON'S SON & CO.

1012 WALNUT STREET

1912

⌞

COPYRIGHT, 1911, BY P. BLAKISTON'S SON & Co.

QD115
S69
1912
D

PREFACE TO FIFTH EDITION.

This edition contains, as new material, the essentials of all that has appeared upon electro-analysis during the past four years. It has not been thought advisable to modify the recommendations under the rapid methods for metal determinations or those in which the mercury cup and rotating anode are used, beyond emphasizing ordinary care and the addition of data arising from experience. The daily studies in this laboratory confirm the wide utility of the mercury cup, as well as that of the double-cup, by means of which anions are estimated with greatest accuracy, and determinations and separations of the alkali metals are made with ease and comfort. It is hoped that these methods may come into more extended use, as they are certain to demonstrate their own advantages and trustworthiness.

It is a pleasure to the author to acknowledge his indebtedness to many friends for suggestions, to his students for their hearty response in the execution of hundreds of determinations and separations made to try out the various schemes, and particularly to his friend and associate, Dr. Jacob S. Goldbaum, whose extended oversight of the practical work of students in electro-chemistry has given him the best of opportunities to study critically all the material printed in these pages, which have passed through the press under his supervision in the writer's absence from home.

S.

THE JOHN HARRISON LABORATORY OF
CHEMISTRY.

40934

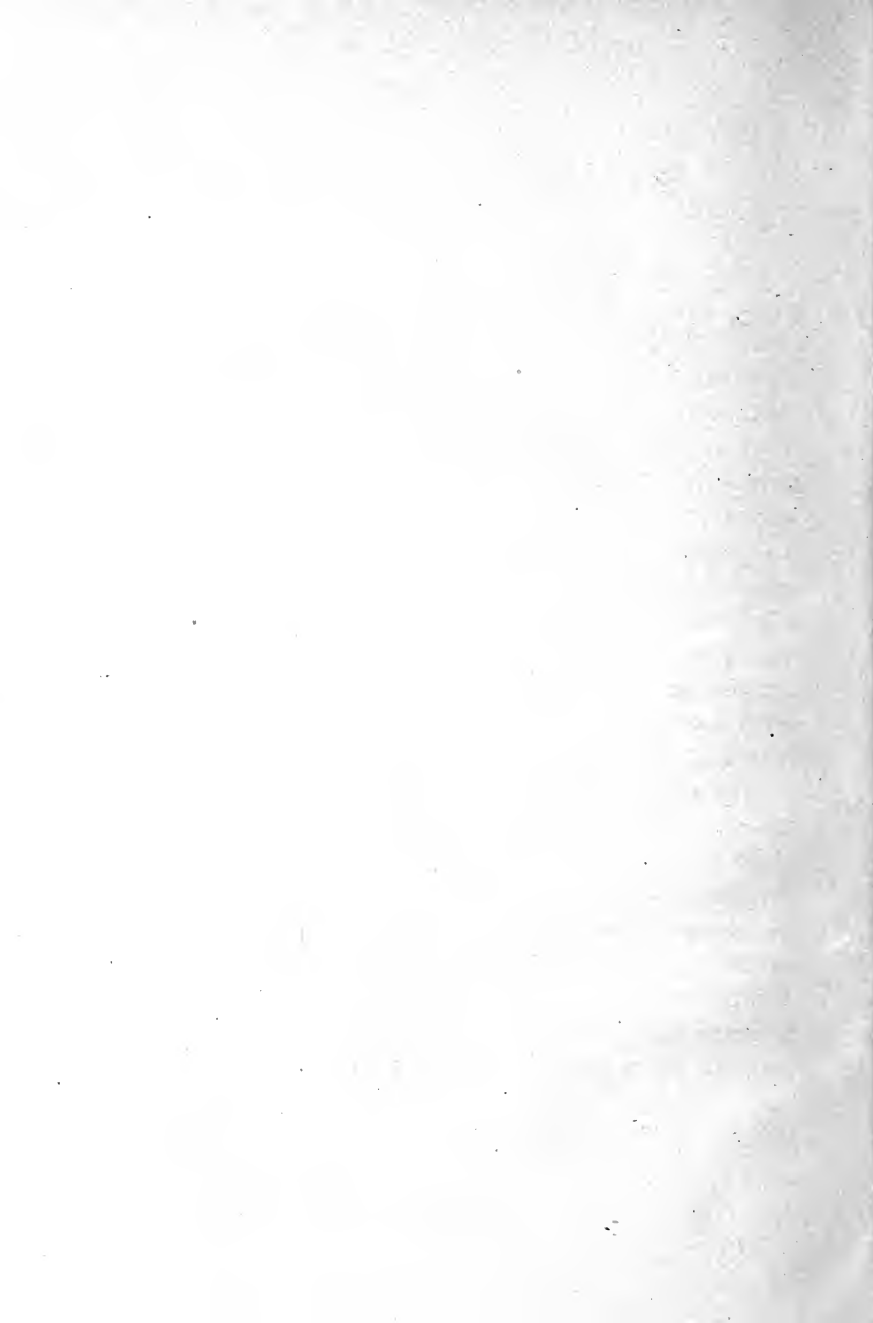

PREFACE TO FOURTH EDITION.

It appeared advisable to omit from this edition the several sections relating to the various sources of the current, particularly those in which the older forms of battery were described. It is true that the use of these sources of electric energy will probably continue, but their construction, treatment and efficiency are so well understood that any particular information about them is best obtained from publications devoted especially to them.

The greater portion of the new material, presented in the pages which follow, refers to the rapid precipitation and separation of metals, the use of a mercury cathode with rotating anode and the employment of a new cell in the determination of cations and anions. To give this material the space it so abundantly deserves suggested the elimination of the minute directions found in the various electrolytes used with stationary electrodes, but it developed that beginners in electroanalysis learn much from the execution of details, the handling of deposits and other points which arise constantly in work of this character. Further, there will always be persons who, from preference or from the lack of facilities to carry out the newer methods, will make determinations and separations with stationary electrodes. Indeed, these earlier methods constitute a fundamental step in the development of analysis through the agency of the current, and are therefore retained in their original forms, except where experience has recommended alterations. So long as the time factor continues to

be of no moment the older procedures will appeal to the analyst.

It may be stated that the rapid methods of analysis set forth in detail in this text, including those in which the mercury cathode plays an important rôle, have been subjected to rigorous tests in this laboratory and have invariably brought success to all working with ordinary care.

The section describing the determination of cations and anions cannot fail to excite interest and inquiry. That the estimation, for example, of barium and chlorine, in barium chloride, may be made in an hour or less, while hours would be required by time-honored methods, will naturally lead one to pause. The neatness and accuracy of such determinations also recommend them. The determination of the ferro- and ferri-cyanogen and other anions indicates still greater possibilities in the application of the current to analysis.

The very latest proposals regarding the value of graded potential in separations and the possibility of effecting organic combustions by means of the electric current receive ample consideration.

The paragraphs on theoretical considerations will throw much light upon the deportment of metals in solution and assist in explaining many heretofore obscure reactions.

Confident that the latest advances in electro-chemistry will win many additional friends to this most interesting field of investigation, these prefatory observations may be concluded with an acknowledgment of great indebtedness and profound gratitude to the many students and friends who have shared in this particular study and made thereby possible the appearance of the present volume.

S.

TABLE OF CONTENTS.

	PAGE
INTRODUCTION	I
1. SOURCES OF ELECTRIC CURRENT—Magneto-Electric Machines, Dynamos, Thermopile, Storage Cells . . .	1-4
2. REDUCTION OF THE CURRENT—Rheostats, Resistance Frames	4-8
3. MEASURING CURRENTS—Voltmeter, Voltmeter, Am- peremeter.	8-11
4. AN ELECTRO-CHEMICAL LABORATORY	11-18
5. HISTORICAL SKETCH	18-30
6. THEORETICAL CONSIDERATIONS	30-39
7. RAPID PRECIPITATION OF METALS IN THE ELECTRO- LYTIC WAY	39-60
8. USE OF MERCURY CATHODE	60-67

SPECIAL PART.

1. DETERMINATION OF METALS	69-183
2. SEPARATION OF METALS	183-274
3. ADDITIONAL REMARKS ON METAL SEPARATIONS	274-284
4. DETERMINATION OF THE HALOGENS IN THE ELECTRO- LYTIC WAY	285-289
5. DETERMINATION OF NITRIC ACID IN THE ELECTROLYTIC WAY	289-292
6. SPECIAL APPLICATION OF THE ROTATING ANODE AND MERCURY CATHODE IN ANALYSIS	292-313
7. OXIDATIONS BY MEANS OF THE ELECTRIC CURRENT	313-317
8. THE COMBUSTION OF ORGANIC COMPOUNDS	317-328

INDEX	329-332
-----------------	---------

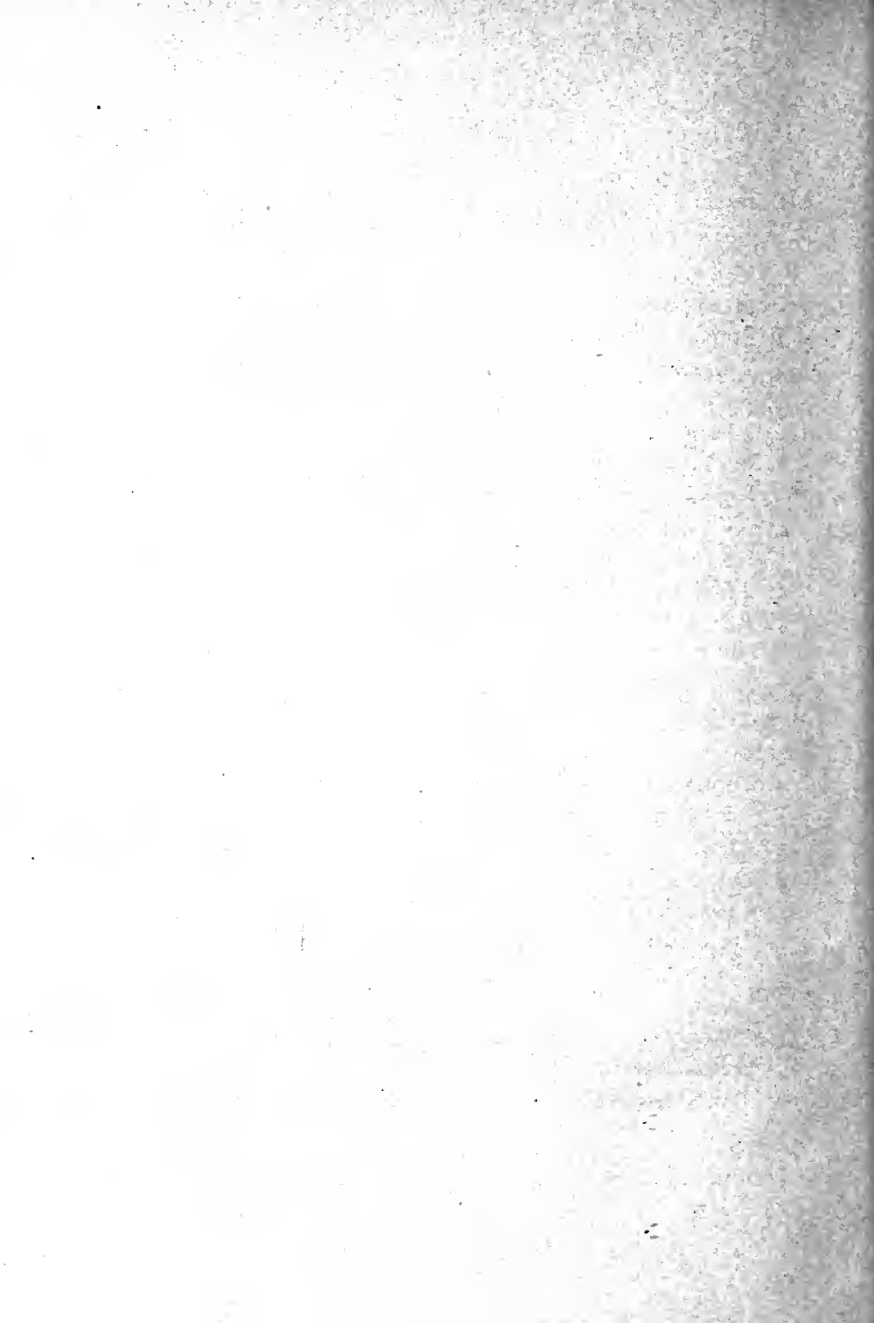

ABBREVIATIONS.

AM. CH.	=	<i>The American Chemist.</i>
AM. CH. JR.	=	<i>American Chemical Journal.</i>
AM. JR. SC. AND AR.	=	<i>American Journal of Science and Arts.</i>
AM. PHIL. SOC. PR.	=	<i>Proceedings of the American Philosophical Society.</i>
ANN.	=	<i>Annalen der Chemie und Pharmacie.</i>
ANN. DE CH. ET DE PHY.	=	<i>Annales de Chimie et de Physique.</i>
BER.	=	<i>Berichte der deutschen chemischen Gesellschaft.</i>
BERG-HÜTT. Z.	=	<i>Berg- und Hüttenmännische Zeitung.</i>
B. S. CH. PARIS.	=	<i>Bulletin de la Société Chimique de Paris.</i>
CH. N.	=	<i>Chemical News.</i>
CH. Z.	=	<i>Chemiker-Zeitung.</i>
C. R.	=	<i>Comptes Rendus.</i>
DING. P. JR.	=	<i>Dingler's Polytechnisches Journal.</i>
ELEKTROCH. Z.	=	<i>Elektrochemische Zeitschrift.</i>
ENG. MIN. JR.	=	<i>Engineering and Mining Journal.</i>
G. CH. ITAL.	=	<i>Gazetta chimica italiana.</i>
JAHRB.	=	<i>Jahresbericht der Chemie.</i>
J. AM. CH. S.	=	<i>Journal of the American Chemical Society.</i>
JR. AN. CH.	=	<i>Journal of Analytical and Applied Chemistry.</i>
JR. F. PKT. CH.	=	<i>Journal für praktische Chemie.</i>
JR. FR. INS.	=	<i>Journal of the Franklin Institute, Phila.</i>
JR. IND. AND ENG. CH.	=	<i>Journal of Industrial and Engineering Chemistry.</i>
JR. PHYS. CH.	=	<i>Journal of Physical Chemistry.</i>
JR. S. CH. IND.	=	<i>The Journal of the Society of Chemical Industry.</i>
M. F. CH.	=	<i>Monatsheft für Chemie.</i>
PHIL. MAG.	=	<i>Philosophical Magazine.</i>
TRANS. AM. ELECTROCH-SOC.	=	<i>Transactions of the American Electro-chemical Society.</i>
WIED. ANN.	=	<i>Wiedemann's Annalen.</i>
Z. F. A. CH.	=	<i>Zeitschrift für analytische Chemie.</i>
Z. F. ANG. CH.	=	<i>Zeitschrift für angewandte Chemie.</i>
Z. F. ANORG. CH.	=	<i>Zeitschrift für anorganische Chemie.</i>
Z. F. ELEKTROCHEM.	=	<i>Zeitschrift für Elektrochemie.</i>
Z. F. PH. CH.	=	<i>Zeitschrift für physikalische Chemie.</i>

ELECTRO-ANALYSIS.

INTRODUCTION.

Many chemical compounds are decomposed when exposed to the action of an electric current. Such a decomposition is called *Electrolysis*. The substance decomposed is termed an *electrolyte*. The products of the decomposition are the *anions* and *cations*, or those (1) which separate at the *anode*, the positive electrode or pole (+P), and (2) those separating at the *cathode*, the negative electrode or pole (—P) of the source of the electric energy.

This behavior of compounds has become of great service to the analyst, inasmuch as it has enabled him to effect the isolation of metals from their solutions, and by carefully studying the electrolytic behavior of salts it has been possible for him to bring about quantitative determinations and separations.

This method of analysis—analysis by electrolysis—has been designated *electro-chemical analysis* or, better, *Electro-analysis*. It is especially inviting, since it permits of clean, accurate and rapid determinations where the ordinary methods yield unsatisfactory results. This statement will at once be confirmed on recalling the gravimetric methods usually employed in the estimation of copper, mercury, cadmium, bismuth, tin, or almost any metal.

I. SOURCES OF THE ELECTRIC CURRENT.

The electric energy required for quantitative analysis has been variously derived from batteries of well-known types

(see Ayrton's Practical Electricity), magneto-electric machines, dynamos (see Oettel's Electrochemical Experiments), thermopiles (Z. f. a. Ch., 15, 334; Z. f. ang. Ch. (1890), Heft 18, 548; Elektrotechnische Zeitschrift, 11, 187; Z. f. a. Ch., 14, 350; 17, 205; Ding. p. Jr., 224, 267; Z. f. a. Ch., 18, 457; 25, 539), and electrical accumulators or storage cells, which are unquestionably the best source. The current from them is constant. Cells of this kind may be charged from primary batteries, or, better, by means of a dynamo or thermopile. In any community where electric lighting is employed it is possible to have the charging done at little expense, and in factories, where there is always sufficient power, a small dynamo may easily be arranged for this purpose, so that almost any number of cells can be kept in condition for work. The iron estimations required by any establishment may be rapidly and accurately made with three cells of this type; little attention would be demanded from the chemist. While storage cells can be used in almost every description of electrolysis, there are a great many cases where economy would suggest the use of the cheaper batteries. Consult the following literature upon storage batteries:

Wied. Ann., 34 (1888), 583; Proceedings of the Royal Society, June 20, 1889; Transactions of Am. Inst. Mining Engineers (Electrical Accumulators, S a l o m), Feb., 1890. Elektrotechnische Zeitschrift, Jahrg. 1890; H e p p e, Akkumulatoren für Elektrizität, Berlin, 1892; Z. f. ang. Ch., 1892, p. 451; Ch. Z., 17, 66; Die Akkumulatoren, Elbs, 2te Auflage, 1896, Leipzig; Introduction to Electrochemical Experiments, F. O e t t e l (translation by S m i t h), Philadelphia, 1897; P f i t z n e r, Die elektrischen Starkströme, Leipzig; D o l e z a l e k, Theory of the Lead Accumulator; W a d e, Secondary Batteries.

Stillwell and Austen have recently suggested the use of the electric light current for the determination of metals in the electrolytic way. That portion of their communication, in which is embodied all that is essential for those desirous of adopting this method, will be found in the following quotation: "The whole apparatus can be made from a few yards of in-

insulated copper wire, some 16 wooden lamp sockets, and blackened lamps, say six 50-candle power, three 32-candle power, six 24-candle power, and six 16-candle power. . . . Binding screws, connections, and plugs will also be necessary in addition to those which are put in with the electric wires.

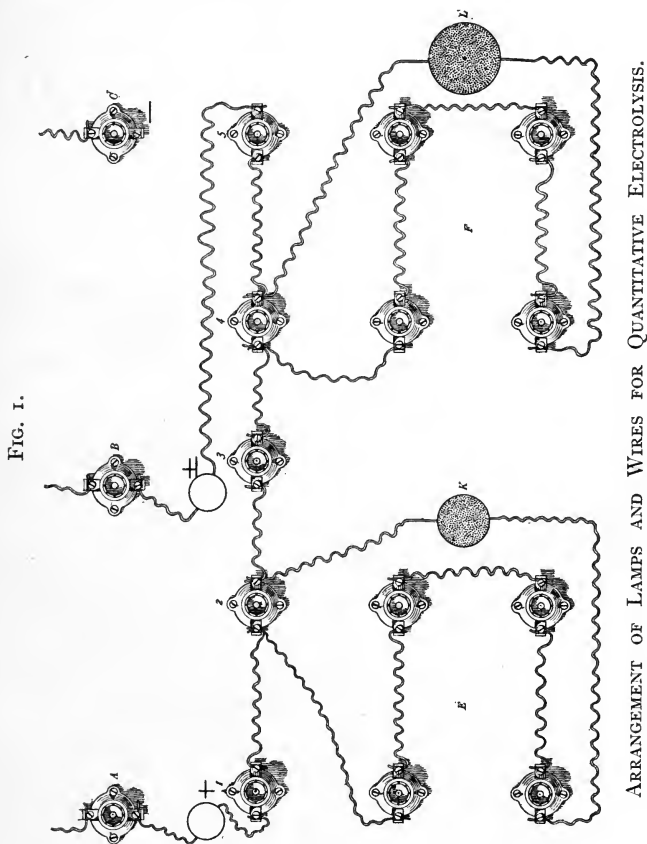

“The main wires +, ±, —, are furnished with sockets A, B, C for the introduction of safety plugs, which, for the small currents used in electrolytic work, need not exceed 6 lamp leads. The main wires terminate in binding screws,

by which they are connected with the series of sockets 1, 2, 3, 4, 5. In these lamps for reducing the main current are placed, and if only one determination or like determinations are required to be made, only this series will be necessary if ordinary currents are required. If, however, two or three different determinations, or some requiring very small currents, are to be made, side currents can be formed as around sockets 2 and 4, and the current brought to the desired size by the introduction of resistances in the series of sockets E and F. K and L will represent the proper position of the solutions to be electrolyzed by these side currents. By this arrangement three unlike determinations can be simultaneously made, one in the main circuit, and one in each of the side-series. If more determinations are required, other sets of sockets may be put up and potentials be taken over other lamps. The sockets may be placed on the wall above the desk, the wires leading down to the solutions to be electrolyzed." (Jr. An. Ch., 6, 129.) Any other arrangement may be adopted. That just described can be adjusted to the parallel system.

The current may be derived from an Edison three-wire system or from any other incandescent system.

See Herlant, Bull. de l'Assoc. belge des Chim., 18, 232.

Hart has devised a resistance frame to be used when the electric light current is employed for electrolytic purposes. It is simpler in construction than that described in the preceding paragraph. Particulars in regard to it may be obtained from Baker & Adamson, Easton, Pa.

2. REDUCTION OF THE CURRENT.

It is often necessary to reduce strong currents. Persons acquainted with practical physics will promptly suggest the resistance coils found in physical laboratories as suitable for

this purpose. They are, on the whole, quite satisfactory, and have been thus utilized, although simpler and more convenient current-reducers have made their appearance from time to time. A few of these later appliances may be mentioned:

The current may be sent through a saturated solution of zinc sulphate, contained in a large glass cylinder, about 22 cm. long and 8.5 cm. in diameter. In one experiment the current

FIG. 2.

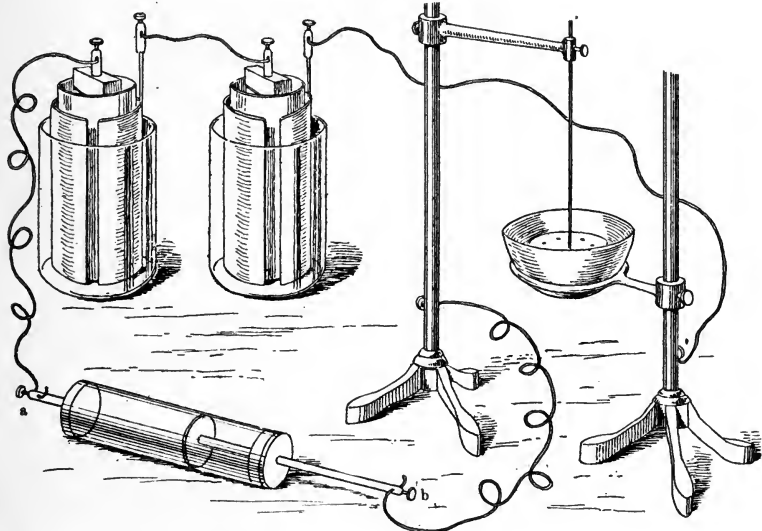

is passed from *a* to *b* (Fig. 2), and in the next from *b* to *a*. "The rod *b*, with one zinc pole, is pushed toward the zinc pole *a*, until the current reaches the desired strength." It is well to amalgamate the zincs from time to time. We are indebted for this piece of apparatus to Classen, who has also described another simple rheostat (Fig. 3) (Ber., 21, 359). In this apparatus the current enters at *a*, travels the German silver resistance *N*, and returns through *b* to the battery.

In the performance of electrolytic depositions the platinum vessels, serving as negative electrodes, may be connected with any one of the binding-posts from 1 to 20. This makes it

FIG. 3.

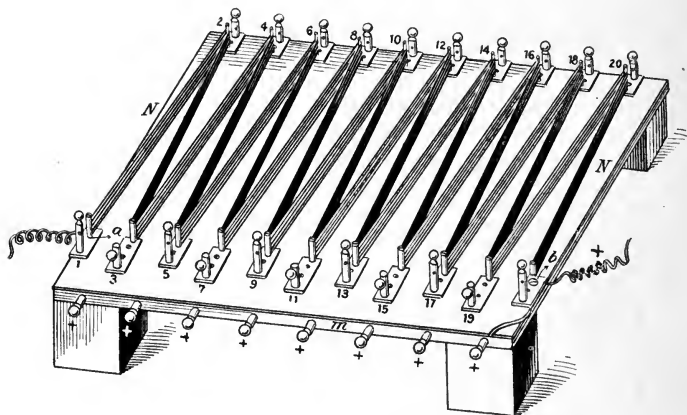

FIG. 4.

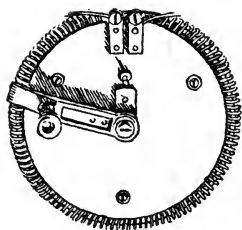
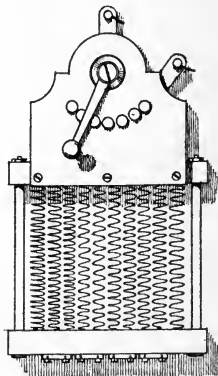

FIG. 5.



possible for the analyst to execute eight different determinations at the same time. To show the influence of this apparatus, a current from five Bunsen cells, generating .68 c.c. of oxyhydrogen gas per minute, was allowed to act upon similar

copper solutions contained in six vessels. The current at binding-post 1 was found to be equal to 3.75 amperes; at 2, it equaled 2.617 amperes; at 3, 2.085 amperes; at 4, 1.911 amperes, etc., until at 20 it was only 0.098 of an ampere.

FIG. 6.

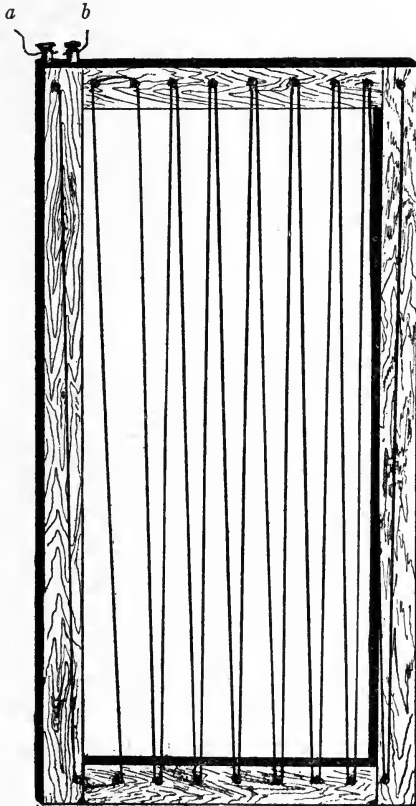

To better understand these figures it should be remembered that an ampere equals 10.436 c.c. of oxyhydrogen gas per minute, or it is equivalent to a current which will precipitate 19.69 mg. of metallic copper, or 67.1 mg. of metallic silver in one minute.

For a larger form of apparatus somewhat similar to that described above, see Ber., **17**, 1787. Figs. 4 and 5 represent other forms of convenient and helpful rheostats.

The writer has for some time employed a much simpler current-reducer, which has the advantage of cheapness and ready construction to recommend it. It consists of a light wooden parallelogram, about six feet in length. Extending from end to end, on both sides, is a light iron wire, measuring in all about 500 feet (Fig. 6). With the binding-posts at *a* and *b*, and a simple clamp, it is possible to throw in almost any resistance that may be required. It answers all practical purposes. The various types of modern laboratory sliding rheostats are likewise convenient and efficient for electro-analysis.

LITERATURE.—v. Klobukow, Jr. f. pkt. Ch., **37**, 375; **40**, 121; Oettel's Electrochemical Experiments (Smith), P. Blakiston's Son & Co., Phila.

3. MEASURING CURRENTS—VOLTAMETER, VOLTMETER, AMPEREMETER.

In every analysis by electrolysis it is advisable that the strength of the acting current should be known. The Bunsen voltameter may be used for this purpose. Voltameters of this description are, however, only in rare cases adapted for current measurement by introduction into the circuit. To read them the current must generally be interrupted, and they augment the resistance of the circuit to a marked degree, hence many chemists substitute a galvanometer (tangent or sine) for the voltameter. The deflection of the needle by the current measures the strength of the latter. "In order to express in terms of chemical action the deflection of the needle, it is placed in the same current with a voltameter, and the deviation of the needle is observed, as well as the volume of electrolytic gas (reduced to 0° and 760 mm. pressure) which

is produced in a minute. Placing the volume equal to v , the quotient $\frac{v}{\tan. a}$ gives the standard value for the galvanometer. If this standard value is denoted by R , the strength, I , of a current which produces the deviation a , is $I = R \tan. a$."

The writer has found the amperemeter of Kohlrausch very satisfactory, especially in cases where strong currents are employed. In this instrument the current travels through an insulated wire surrounding a bar of soft iron. The latter, in its magnetized state, attracts a needle or indicator and causes it to move over a vertical, graduated scale (in amperes), and its deflection gives at once the strength of the current in amperes. The Weston milliamperemeters and ammeters, as well as other modern types of current meters, will also prove most valuable in this connection.

In electrolytic work of any kind it is advisable that the apparatus intended to measure the current strength should be in the circuit during the entire decomposition, for it is only in this way that we can expect to effect separations without encountering unpleasant difficulties. It is necessary to know just what energy is required, and then so to regulate the current that the same is approximately maintained throughout the entire determination.

When metals were first determined electrolytically no attention was given to certain very important factors. "Strong" and "feeble" currents, or currents from a two-cell bichromate battery, or five large Bunsen cells, etc., were indicated. Measuring instruments were seldom used. Rarely was anything said of the size of the cathode upon which the metal was deposited, or of the forms of the anode, the degree of dilution of the solution, and similar facts. Confusion naturally arose and contradictory statements of one kind and another were numerous. But in this, as in all other questions where there was a real desire to arrive at the truth, honest experiment soon pointed the way in which changes were necessary and

also demonstrated the conditions to be observed in order that satisfactory results might be obtained. Probably then, as at present, the metal depositions were mainly made in platinum dishes, or upon cylinders or cones. These receptacles, as well as the various anode forms, will receive thorough consideration later. It is the purpose of the writer at this point to merely emphasize the most essential features in an electrolytic determination or separation. Hence note:

1. The *current density*. To this end the inner surface of the platinum dish in which the electrolysis is made should be known in cm^2 ; its contents, too, should be given in cm^3 for various heights. $N.D._{100}$ is the *normal density* of the current; this is equivalent to the current strength for 100 cm^2 of the electrode surface. The density (D) therefore is dependent upon the current strength, as well as upon the surface (E) of the electrode upon which the metallic deposit is precipitated, *i. e.*, $D = \frac{C}{E}$.

When the surface upon which the metal is deposited equals E, the corresponding current strength can be deduced from the formula $C = (N.D._{100}) \cdot \frac{E}{10}$. See, further, Miller and Kiliani, *Lehrbuch der analyt. Chemie*, 4th ed., pp. 17-24.

2. The *potential across the poles*,—the pole pressure,—which is best determined by means of a Weston voltmeter (p. 70). This is a very important factor. A number of interesting separations have been made by carefully regulating the pressure—voltage. See *Z. f. ph. Ch.*, 12, 97; also pp. 30-39.

3. The form of the anode—whether a flat spiral, a disk of platinum, or a smaller perforated dish, suspended in the electrolyte, or any other kind of electrode surface—should also be observed, as well as its distance from the cathode.

4. The total dilution of the electrolyte, its concentration, and its temperature are items of value.

5. The ammeter and voltmeter should always be in the circuit.

Under the individual metals these points will be taken up more fully. By strict adherence, however, to these cardinal features no one need fear the outcome. It will in every way be satisfactory.

As the importance of electro-analysis has become evident, there has been marked improvement in the various forms of apparatus used in this work, and increased facilities for the same are noticed on all sides. In every well-appointed laboratory provision is made for this field of study, and in certain institutions rooms are set aside and especially equipped to carry out such work. Here at the University of Pennsylvania, where electro-analysis was practiced as early as 1878, with no special appointments and with the most primitive forms of apparatus, there has been a gradual evolution and development in apparatus and facilities according to demands and with increased knowledge, until recently an installation has been made for this as well as for other lines of work in electro-chemistry, which is characterized by great completeness and such simplicity that a brief sketch of the plant may be well introduced here.

4. AN ELECTRO-CHEMICAL LABORATORY.

This laboratory will accommodate at least sixteen students, working continuously. The room available for this purpose (Fig. 7) is fifteen feet by twenty-six feet, thus affording each individual three feet by twenty inches of table space.

Storage cells supply the energy. Those in use have a capacity of 120 ampere-hours, with a normal discharge rate of 15 amperes and a maximum rate of 30 amperes. The compartments, indicated at the end of the room, contain two groups of twenty-four cells each. They supply their respective sides of the room. They are supported on racks of four shelves each, six cells per shelf. Each shelf is thor-

ELECTRO-ANALYSIS.

FIG. 7.

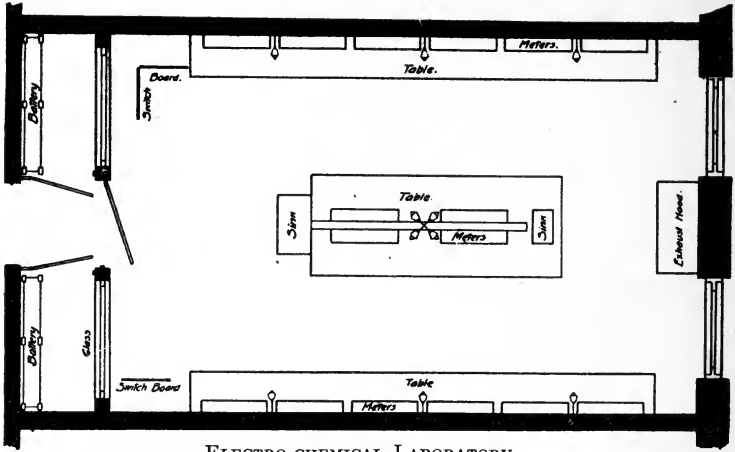

ELECTRO-CHEMICAL LABORATORY.

FIG. 8.

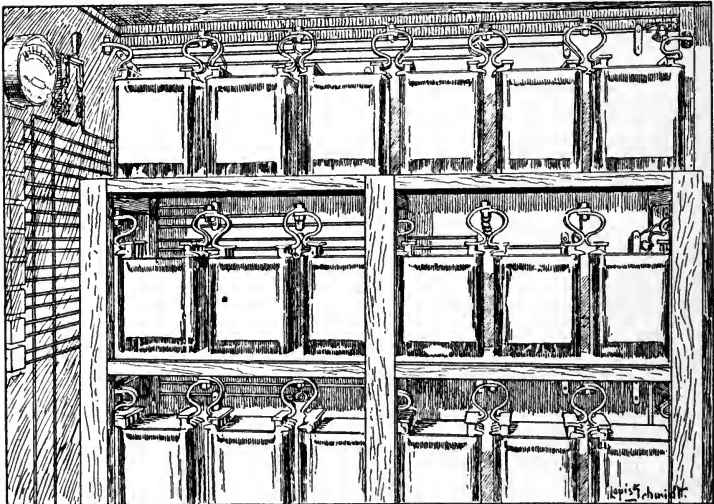

BATTERY ROOM.

oughly paraffined and a half-inch layer of ground quartz is placed around the jars. Fig. 8 shows one of these compartments with the lead wires and cut-outs for each cell.

The switchboards are three in number, two of them each

FIG. 9.

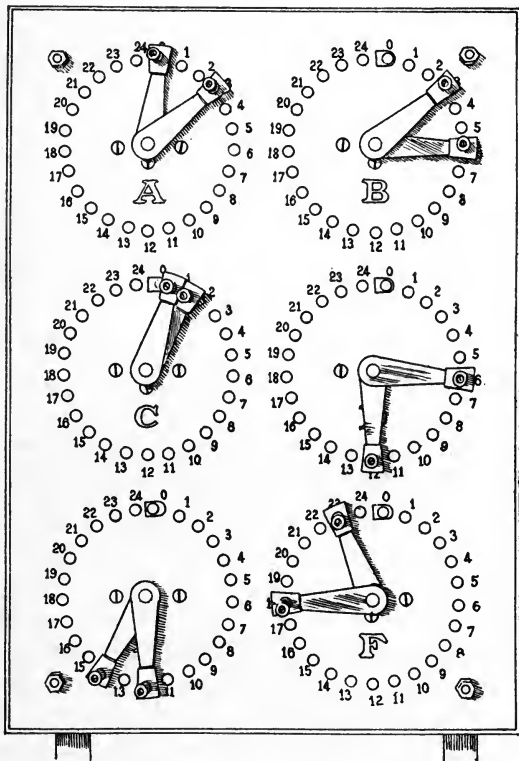

DISTRIBUTING BOARD.

controlling the six places on their respective sides of the room, and the third controlling the four places in the centre. The face of one of these boards is shown in Fig. 9, the letters on the face referring to the working tables controlled.

The switchboard on the east side of the room consists of a slab of enameled slate twenty-four by thirty-four inches, one inch thick, and contains, for each of the six outlets to be controlled, one circle of twenty-five contact pieces, and has two spring levers, insulated from each other and moving about a common centre, sweeping over them. The contact blocks are numbered consecutively from 0 to 24 and a stop is provided to prevent the levers from sweeping past the zero. Cell No. 1 is connected between blocks numbered 0 and 1 in each of the six circles, cell No. 2 between blocks numbered 1 and 2, and so on for the remainder of the twenty-four cells in that group, so that all blocks similarly numbered on the one board are connected together, and but a single wire leads from the six similarly numbered blocks to the junction between two cells. In this lead, is provided the usual fuse. The circles are lettered A, B, C, etc., consecutively, corresponding with the letters at the outlets to be controlled.

Should the operator at the outlet E, for instance, need two cells, he goes to this board, and finding that the cells from the twelfth cell forward are not being used in any of the circles, he places one of the levers on contact block No. 12 and the other one on No. 14. There is thus very little chance of doing anything wrong, or for persons to interfere with one another, because there is no necessity to use the same cells; and at a glance one can observe which cells are in use. Fig. 10 shows the electrical connections from one of these distributing boards to the cells and outlets on the working tables. The levers themselves are too narrow at their outer ends to reach across from one block to another, to prevent short-circuiting the cells, so they are provided with fibre extensions on each side to prevent their falling between the blocks, and also to prevent their making contact with each other.

The switchboard on the west wall is exactly similar to the one just described. It contains the circles G, H, I, K, L, and

M, while the third one, which controls the four outlets on the centre table, is only twenty-four inches square, but has twenty-six contact blocks in each circle. They are numbered 0, 24, 25, 26, and so on to 48. Between the two blocks numbered 0 and 24 are connected the cells of the group on the east side of the room; between the blocks 24 and 25 is connected cell No. 1 of the west side of the room, while cell No. 2 is connected between blocks numbered 25 and 26. This arrangement connects the two groups of cells in series, and permits the use of from one to forty-eight cells at the centre table when necessity

FIG. 10.

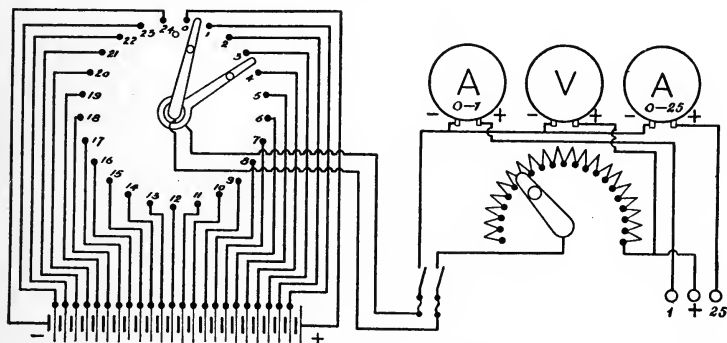

CONNECTIONS TO WORKING TABLE.

requires. It will, perhaps, have been noticed that there is no provision made for connecting cells in parallel, and this is not necessary, as the maximum discharge rate of the cells exceeds the greatest estimated current needed by one operator.

All brass parts on the back of the board, as well as the bared ends of the wires, are thoroughly coated with P. and B. paint, while the brass parts on the front are heavily lacquered to prevent corrosion. The surface of the contact blocks can be easily cleaned with fine sandpaper.

The measuring instruments, after some deliberation, were

chosen of the switchboard type. While this necessitated procuring at least one-third more instruments, yet the initial cost was considerably lower than if portable instruments had been provided, and experience with portable instruments has shown that a greater accuracy will be attained with switchboard instruments of a good form, if not immediately, yet surely after the first six months of use.

Each outlet is provided with a fused switch, a voltmeter, two ammeters, a rheostat, and a terminal board. They are connected as shown in Fig. 10. The positive lead after passing through the variable resistance runs directly to the positive binding-post. The wire coming from the negative binding-post runs to the low-reading ammeter and thence to the negative side of the switch, while the negative post marked 25 is connected to the same switch terminal, but through the ammeter of large capacity. The anode of the electrolytic cell is therefore always connected to the middle binding-post and the cathode either to post 1 or 25, depending upon the strength of current it is intended to pass through the cell. The voltmeter, being connected as shown, measures the potential differences at the terminals of the cell, except for the addition of the small fall of potential through the ammeters.

The voltmeters on the side of the room have scales ranging from 0 to 50, and divided to 1-2 volts. Those on the centre table range from 0 to 120.

The ammeters ranging from 0 to 1 ampere are divided to 1-100, and those reading from 0 to 25 are divided to 1-5 amperes. The three instruments are mounted side by side on an oak backboard extending the whole length of the room and are covered by an air-tight case with a glass front, as shown in Fig. 11. The cases have neither doors nor a back; but are simply screwed against a backboard with a heavy felt gasket, making the joint. The wires come out through hard rubber tubes sealed at their outer ends by insulating tape.

The sliding rheostats are of the enameled type, chosen because of their being impervious to fumes. They have a total resistance of 172 ohms, divided into 51 steps in such a way that their resistances form a geometrical progression, the first step and the sum of all the steps being chosen in accordance with data of the resistances of the baths determined for the work done under an earlier system. Each desk is furnished

FIG. II.

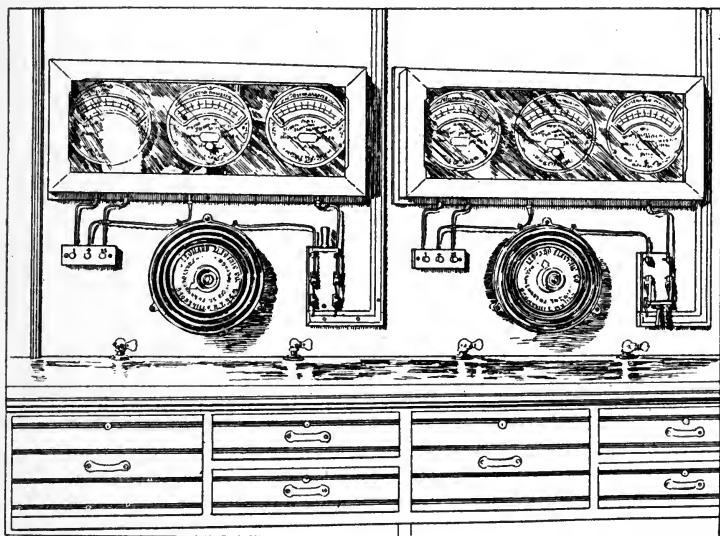

WORKING TABLE.

with a motor and stand for work with rotating electrodes. A rheostat is placed in series with each motor. A range of 150 to 1200 R. P. M. is thus at hand.

The wires, both those in the battery rooms and those in the laboratory proper, are covered with rubber, and those in the laboratory are further encased in oak moulding, but this rather for the sake of appearance than for protection. The whole installation, as well as the other fittings of the

room, has a very neat and finished appearance. (Science, 13, 697 (1901).) The following references may also be consulted:

Z. f. Elektrochem., 8, 398, 445; 9, 496; 10, 238. H. Nissenson, Einrichtungen von elektrolytischen Laboratorien, etc. Verlag von W. Knapp in Halle a. S. Elektrochemische Zeitschrift 10, 267; Gazzetta chimica italiana, 36, 401; A begg, Z. f. Elektrochem., 12, 109; Foerster, *ibid.*, 12, 183. Classen, Z. f. Elektroch., 13, 381; *ibid.*, 15, 601; Mahin, Electroch. and Metallurgical Industry, 7, 438; Fichter, Z. f. Elektroch., 17, 518.

Before taking up the description of the details to be observed in the electrolytic precipitation of individual metals, it may not be uninteresting to briefly trace the history of the introduction of the electric current into chemical analysis.

5. HISTORICAL.

Although the early years of last century show considerable activity in electrical studies, the efforts were mainly directed to the solution of the physical side of electrolysis. Cruikshank (1801), observing the readiness with which the metal copper was precipitated by the current, first suggested electricity as a possible agent in the detection of metals. Fischer (1812) detected arsenic, and Cozzi (1840) the metals generally in animal fluids by this means, while Gaultier de Claubry (1850) directed his efforts wholly to the isolation of metals from poisons by depositing the same upon plates of platinum. When the precipitation was considered finished the plates were removed, carefully washed, and the deposited metals brought into solution with nitric acid, and there tested for and identified by the usual course of analysis. The current was evidently very feeble, as the time recorded as necessary for the deposition varied from ten to twelve hours. Gaultier considered this method reliable in all instances, but especially recommends it for the separation of copper from bread. In testing for zinc

he employed a strip of tin as anode, but states that a platinum plate will answer as well.

In Graham-Otto's *Lehrbuch der Chemie* (1857) it is stated that the oxygen developed at the positive electrode readily induces the formation of peroxides; . . . that lead and manganese peroxides are deposited, from solutions of these metals, upon the positive electrode of the battery; . . . that the point of a platinum wire, when attached to the anode of a cell, is therefore a delicate means of testing for manganese and lead. In the same text the oxidizing power of the anode is nicely shown by the following simple experiment: A piece of iron, in connection with the positive electrode of the battery, is introduced into a V-shaped glass tube containing a concentrated solution of potassium hydroxide, while a platinum wire running from a negative electrode projects into the other limb of the vessel. In a short time ferric acid appears around the anode, and is recognized by its color.

C. Despretz (1857) described the decomposition of certain salts by means of the electric current, and remarked that, while operating with solutions of the acetates of copper and lead, he expected both metals would be deposited upon the negative pole, and was much surprised to find that the lead separated as oxide upon the anode at the same time that the copper was deposited upon the cathode. The results were the same when experiments were conducted with the nitrates and pure acetates. With manganese no deposition took place upon the negative electrode, but a black oxide appeared at the opposite pole. Potassium antimonyl tartrate gave a crystalline metallic deposit of antimony at the cathode, and upon the anode a yellowish-red coating, supposed to be anhydrous antimonic acid. Bismuth nitrate yielded a reddish-brown deposit at the positive electrode. Despretz concludes his paper by stating that although the facts were few in number, yet they were new in so far as they concerned lead, anti-

mony, and manganese; and, furthermore, that the separation of copper from lead by the current was almost perfectly complete.

Three years later (1860) Charles L. Bloxam recommended the process of Gaultier for the detection of metals in organic mixtures, although it may not be improper to add that Smee (1851), in his work on electrometallurgy, asserts that Morton was the first person to employ the electric current for the isolation of metals from poisonous mixtures. However this may be, the fact remains that Bloxam did use the current quite extensively for this purpose, and while he claims no quantitative results for the method, the apparatus employed by him and his subsequent work in this direction deserve great credit.

To detect arsenic electrolytically Bloxam made use of a glass jar, four cubic inches in capacity, closed below by parchment, which was tightly secured by means of a thin platinum wire. In the neck of the jar was a large cork, through which passed a glass tube bent at a right angle. This tube was intended to serve as a means of escape for the gases liberated within the jar. The platinum wire from the negative electrode was also held in position by the cork. The portion of the wire within the jar was attached to a platinum plate dipping into the arsenical mixture containing dilute sulphuric acid. The jar with its contents stood in a wide beaker, filled with water, into which dipped the positive electrode of the battery. Under the influence of the current, metals like antimony, copper, mercury, and bismuth separated upon the platinum plate of the negative electrode, while arsine was liberated and escaped through the exit-tube into some suitable absorbing liquid. To ascertain what metal or metals had separated upon the cathode, the plate attached thereto was removed, after the interruption of the current, and treated with hot ammonium sulphide. Upon evaporating this solution, an orange-colored spot remained if antimony had been previously present. If

a metallic deposit continued to adhere to the foil, the latter was acted upon by nitric acid to effect the solution of the remaining metals.

J. Nicklès (1862) precipitated silver with the current obtained from a zinc-copper couple. The positive electrode consisted of a piece of graphite, taken from a lead pencil, while a thin, bright copper wire constituted the negative electrode. The silver separated upon this. The current was very feeble, for hydrogen was not liberated at the cathode. Nicklès also suggested the reduction of large quantities of silver from the solution of its cyanide by this means. To obtain the silver he advised using a cylindrical cathode constructed of some readily fusible alloy, so that after the reduction was finished the other metals might be easily melted out and leave a silver plate. Copper, lead, bismuth, and antimony were separated electrolytically from textiles by Nicklès.

In 1862 A. C. and E. Becquerel resumed their electrochemical investigations, first begun some thirty years previously. Their experiments seem to have been aimed chiefly toward the reduction of metallic solutions upon a large scale, caring not for the quantitative estimation of metals, but seeking rather a rapid and satisfactory technical isolation process.

Wöhler (1868) found that when palladium was made the positive conductor of two Bunsen cells, and placed in water acidulated with sulphuric acid, it immediately became covered with alternating, bright, steel-like colors. He regarded the coating as palladium dioxide, since it liberated chlorine when treated with hydrochloric acid, and carbon dioxide when warmed with oxalic acid. Black amorphous metal separated at the cathode. Its quantity was slight. Under similar conditions lead also yields the brown dioxide, and the same may be said of thallium. Osmium, in its ordinary porous form, at once becomes osmic acid. When caustic alkali is

substituted for the acid, the liquid rapidly assumes a deep yellow color, while a thin deposit of metal appears upon the cathode. Ruthenium behaves similarly when applied in the form of powder. Osmium-iridium, a compound decomposed with difficulty under ordinary circumstances, immediately passes into solution when brought in contact with the positive electrode of a battery placed in a solution of sodium hydroxide, and imparts a yellow color to the alkaline liquid. A black deposit of metal slowly makes its appearance upon the negative pole.

The experiments thus far described are qualitative in their results. The first notice of the quantitative estimation of metals electrolytically was that of Wolcott Gibbs (1864), when he published the results he had obtained with copper and nickel. Luckow, in alluding to this work a year later (1865), says: "I take the liberty to observe that so far as the determination of copper is concerned, I estimated that metal in this manner more than twenty years ago, and as early as 1860 employed the electric current for the deposition of copper quantitatively in various analyses." It was Luckow who proposed the name *Elektro-Metall Analyse* for this new method of quantitative analysis. According to this writer the current may be applied as follows:

1. To dissolve metals and alloys in acids by which they would not be affected unaided by the electric current.
2. To detect metals like manganese and lead (silver, nickel, cobalt); separating them in the form of peroxides; also manganese as permanganic acid.
3. To separate various metals, *e. g.*, copper and manganese, from zinc, iron, cobalt and nickel.
4. To deposit and estimate metals quantitatively, in acid, alkaline, and neutral solutions.
5. For various reductions, *e. g.*, silver chloride, basic bismuth chloride, and lead sulphate, in order that the metals

in them may be determined. To reduce chromic acid to oxide, *e. g.*, potassium bichromate acidulated with dilute sulphuric acid.

These applications embrace nearly all that has since been accomplished by the aid of the current. In the same article in which Luckow calls attention to the facts recorded above, he describes minutely the method pursued by him in the precipitation of metals. Reference to these early experiments will show with what care and accuracy every detail was worked out. Luckow also announced "that all the lead contained in solution was deposited as peroxide upon the positive electrode, and might be determined from the increased weight of the latter." This observation was fully confirmed by Hampe, and later by W. C. May.

Wrightson (1876) called attention to the fact that if solutions of copper were electrolyzed in the presence of other metals, the latter greatly influenced the separation of the former. For example, with copper and antimony, the deposition of the copper was always incomplete when the antimony equaled one-fourth to two-thirds the quantity of the former. Notwithstanding, a complete separation of the two metals can be effected when the quantity of the antimony is small. A somewhat similar behavior was noticed with other metals. The deposition of cadmium, zinc, cobalt, and nickel was apparently not satisfactory.

Lecoq de Boisbaudran (1877) electrolyzed the potassium hydroxide solution of the metal gallium, using six Bunsen elements with 20-30 c.c. of the concentrated liquid. The deposited metal was readily detached when the negative electrode was immersed in *cold* water and bent slightly.

The unpromising behavior of zinc solutions, observed by Wrightson, was fortunately overcome by Parodi and Mascazzini (1877), who employed a solution of the sulphate, to which was added an excess of ammonium acetate. Lead was

also deposited in a compact form from an alkaline tartrate solution of this metal in the presence of an alkaline acetate.

After Luckow's experiments upon manganese, little attention appears to have been given this metal until Richè (1878) published his results. While confirming the observations of Luckow, he discovered that manganese was not only completely precipitated from the solution of its sulphate, but also from that of the nitrate, thus rendering possible an electrolytic separation of manganese from copper, nickel, cobalt, zinc, magnesium, the alkaline earth, and the alkali metals. Richè recommended that the deposited dioxide be carefully dried, converted by ignition into the protosesquioxide, and weighed as such. According to this chemist the one-millionth of a gram of manganese, when exposed to the action of the current gave a distinct rose-red color, perceptible even when diluted tenfold.

In zinc depositions Richè gave preference to a solution of zinc-ammonium acetate containing free acetic acid.

Luckow was the first to mention that the current caused mercury to separate in a metallic form, from acid solutions, upon the negative electrode. F. W. Clarke (1878) used a mercuric chloride solution, feebly acidulated with sulphuric acid, for this purpose. The deposition was made in a platinum dish, using six Bunsen cells. Mercurous chloride was at first precipitated, but it was gradually reduced to the metallic form. J. B. Hannay (1873) had previously recommended precipitating this metal from solutions of mercuric sulphate, but gave no results.

Clarke, also, gave some attention to cadmium; his results, however, were not satisfactory. A few months later the writer (1878) succeeded in depositing cadmium completely and in a very compact form from solutions of its acetate. Upon this behavior Yver (1880) based his separation of cadmium from zinc. Furthermore, the writer found (1880) that

the deposition of cadmium could be made from solutions of its sulphate, contrary to an earlier observation of Wrightson. At the same time copper was completely separated from cadmium by electrolyzing their solution in the presence of free nitric acid.

A very successful determination of both zinc and cadmium was published by Beilstein and Jawein in 1879. They employed for this purpose solutions of the double cyanides.

Heinrich Fresenius and Bergmann (1880) found that the electrolysis of nickel and cobalt solutions succeeded best in the presence of an excess of free ammonia and ammonium sulphate.

Their experience with silver demonstrated that the best results could be obtained with solutions containing free nitric acid, and by the employment of weak currents.

The writer (1880) showed that if uranium acetate solutions were electrolyzed, the uranium was completely precipitated as a hydrated protos sesquioxide; and, further, that molybdenum could be deposited as hydrated sesquioxide from warm solutions of ammonium molybdate in the presence of free ammonia. Very promising indications were obtained with salts of tungsten, vanadium and cerium.

In a later (1880) communication from Luckow, to whom we are indebted for much that is valuable in electrolysis, is given a full description of his observations in this field of analysis, from which the following condensed account is taken. While it relates more particularly to the qualitative behavior of various compounds, its importance demands careful study.

When the current is conducted through an acid solution of potassium chromate, the chromic acid is reduced to oxide; whereas, if the solution of the oxide in caustic potash be subjected to a like treatment, potassium chromate is produced. Arsenic and arsenious acid behave similarly. The same is true also of the soluble ferro- and ferri-cyanides and

nitric acid. In the presence of sulphuric acid, ferric and uranic oxides are reduced to lower states of oxidation. Sulphates result in the electrolysis of the alkaline sulphites, hyposulphites, and sulphides, and carbonates from the alkaline organic salts. In short, the current has a reducing action in acid solutions, and the opposite effect in those that are alkaline. In the electrolysis of solutions of hydrogen chloride, bromide, iodide, cyanide, ferro- and ferri-cyanide and sulphide, the hydrogen separates at the electro-negative pole, and the electro-negative constituents at the positive electrode. Cyanogen sustains a more thorough decomposition, the final products being carbon dioxide and ammonia. In the electrolysis of ferro- and ferri-cyanogen, Prussian blue separates at the positive electrode. In dilute chloride solutions hypochlorous acid is the only product, whereas chlorine is also present in concentrated solutions. In alkaline chloride solutions chlorates are produced as soon as the liquid becomes alkaline. In the iodides and bromides, iodine and bromine separate at the positive electrode, while bromates and iodates are formed when metals of the first two groups are present. Potassium cyanide is converted into potassium and ammonium carbonates. Concentrated nitric acid is reduced to nitrous acid; however, when its specific gravity equals 1.2, this does not occur, at least not when a feeble current is used. Dilute nitric acid alone, or even in the presence of sulphuric acid, is not reduced to ammonia. (See also *Z. f. anorg. Ch.*, 31, 289.) If, however, dilute nitric acid be present in a copper sulphate solution undergoing electrolysis, copper will separate upon the negative electrode and ammonium sulphate will be formed. Solutions of nitrates containing sulphuric acid behave analogously. Phosphoric acid sustains no change. Silicic acid separates as a white mass, and boric acid, in crystals uniting to arborescent groups, at the positive electrode.

In the *Ber. d. d. chem. Gesellschaft*, 14 (1881), 1622, Classen

and v. Reiss presented the first of a series of papers upon electrolytic subjects, which continued through subsequent issues of this publication. Their early work was devoted to the precipitation of metals from solutions of their double oxalates. They also elaborated excellent methods for antimony and tin. Many very serviceable forms of apparatus, intended for electrolytic work, were devised and described by them, and it must be conceded that through the activity of the Aachen School, electrolysis acquired more importance in the eyes of the chemical public than it ever before possessed. The details of the more important methods proposed by Classen and his co-laborers will receive due mention under the respective metals.

Quite independently of Classen, Reinhardt and Ihle proposed zinc-potassium oxalate for the estimation of zinc electrolytically; and in this connection it may not be improper to mention that as early as 1879, Parodi and Mascazzini (*Gazetta chimica italiana*, 8, 178) wrote "finally, we may add, that the electrolytic determination of antimony and iron in their derivatives must be considered an accomplished fact judging from the experiments we have happily initiated in this important subject; namely, that antimony is fully precipitated from its chloride dissolved in basic ammonium tartrate, and also from the solutions of its sulpho-salts, while the iron is deposited from a ferric solution in the presence of acid ammonium oxalate."

Both of these suggestions have since been amplified and vastly improved by Classen and his students.

In 1883 Wolcott Gibbs "gave an account of a method of electrolysis for the separation of metals from their solutions by the employment of mercury as negative electrode, the positive electrode being a plate of platinum. Under these circumstances, and with a current of moderate force, it was found possible to separate iron, cobalt, nickel, zinc, cadmium,

and copper so completely from solutions of the respective sulphates that no trace of metal could be detected in the liquid. In addition it was found that phosphates of these metals dissolved in dilute sulphuric acid were easily resolved into amalgams and free acid, and the advantages of the method were pointed out in at least a certain number of cases. The author had in view both the determination of the metal by the increase in weight of the mercury, and in particular cases of the molecule combined with the metal, either by direct titration or by known gravimetric methods." The experiments were purely qualitative, such being in the author's opinion sufficient to establish the correctness of the principle involved. "It is to be hoped that the determination quantitatively of the electro-negative atoms or molecules united with the metal will also attract attention, the method having been originally intended to serve the double purpose." This method is not applicable in the case of antimony and arsenic.

Three years later (1886) Luckow recommended a very similar procedure for the estimation of zinc.

Moore (1886) also published new data upon the estimation of iron, cobalt, nickel, manganese, etc., full notice of which will appear under these metals.

Whitfield (1886) suggested an indirect determination of the halogens electrolytically, which has proved useful.

Brand (1889) succeeded in effecting separations by utilizing solutions of the pyrophosphates of different metals.

Smith and Frankel (1889) made an extended study of the double cyanides, and found thereby a number of very convenient methods of separation heretofore unrecorded. The results of their numerous investigations in this direction are given in detail in the following pages.

Other publications relating to electrolysis are that of Warwick on metallic formates (*Z. f. anorg. Ch.*, 1, 285), that of Frankel on the oxidation of metallic arsenides (*Ch. N.*, 65,

54), and that of Vortmann (*Ber.*, **24**, 2749) upon the electro-deposition of metals in the form of amalgams, together with a series of critical reviews of electrolytic methods by Rüdorff in the *Z. f. ang. Ch.*, 1892.

In the years immediately following the recording of the preceding experiments the efforts in electro-analysis had for their chief purpose the perfecting of methods. The absence of reliable working conditions necessitated a careful review of earlier suggestions, with the result that while some have been abandoned, the greater number have been re-enforced and have been given a more favorable and extended use. Freudenberg (1893) revived the idea to which Kiliani first called attention, viz.: that by the application of suitable decomposition-pressures metal separations could be easily executed in the electrolytic way. This contribution, published in the *Z. f. ph. Ch.*, **12**, 97, and epitomized on pp. 31-37, should be seriously studied by all persons interested in electro-analysis. Singularly enough, the separations therein indicated had been previously made by Smith and Frankel (1889), and the statement also appears that by the use of the double cyanides the field of separations was widely extended. (See also *J. Am. Ch. S.*, **16**, 93.)

Other contributions have considered the availability of known electro-chemical methods to technical analysis, and many, too, have been almost wholly controversial in their character, so that they may be omitted here. The literature references to them appear in their appropriate places.

The most recent advances in electro-analysis embrace the rapid determination of metals by agitation of the electrolyte, and the use of a mercury cathode. A complete account of the results achieved by these means will appear upon the subsequent pages.

The preceding paragraphs give a brief outline of what has

been accomplished in the field of analysis by electrolysis; for further information consult the following:

LITERATURE.—Jahr., 1850, 602; C. r., 45, 449; Jr. f. pkt. Ch., 73, 79; Chem. Soc. Quart. Journ., 13, 12; Jahr., 1862, 610; Ann., 124, 131; C. r., 55, 18; Ann., 146, 375; Z. f. a. Ch., 3, 334; Ding. p. Jr. (1865), 231; Z. f. a. Ch., 8, 23; 11, 1, 9; 13, 183; Am. Jr. Sc. and Ar. (3d ser.), 6, 255; Z. f. a. Ch., 15, 297; Ber., 10, 1098; Annales de Ch. et de Phys., 1878; Am. Jr. Sc. and Ar., 16, 200; Am. Phil. Soc. Pr., 1878; Z. f. a. Ch., 15, 303; Am. Ch. Jr., 2, 41; Berg-Hütt. Z., 37, 41; Z. f. a. Ch., 19, 1, 314, 324; Am. Ch. Jr., 1, 341; B. s. Ch. Paris, 34, 18; Ber., 12, 1446; 14, 1622, 2771; 17, 1611, 2467, 2931; 18, 168, 1104, 1787; 19, 323; 21, 359, 2892, 2900; Jr. f. pkt. Ch., 24, 193; Z. f. a. Ch., 18, 588; 22, 558; 25, 113; Ch. N., 28, 581; 53, 209; Ber., 25, 2492; Z. f. ph. Ch., 12, 97; Ber., 27, 2060; Z. f. Elektrochem., 2, 231, 253, 269; Z. f. a. Ch. (1893), 32, 424. And the following will be found worthy of careful study: Ann., 36, 32; 94, 1; Z. f. a. Ch., 19, 1; Berg-Hütt. Z., 42, 377; Z. f. a. Ch., 22, 485. Paweck, Elektrotechnische Zeitschrift x, 243; Foerster and Müller, Z. f. Elektroch., 8, 515; Medicus, Z. f. Elektroch., 8, 569; 8, 696; Perkin, Electrolytic apparatus, Ch. N., 88, 102; J. E. Root, Electrochemical Analysis and the Voltaic Series, Jr. phys. Chem., 7, 428; Holland, Influence of the Nature of the Cathode on the Quantitative Separation of Metals by Electrolysis, Ch. N., 88, 5; *ibid.*, 89, 110; 87, 193; Foerster, Z. f. Elektroch., 14, 3; 14, 208; Dauvé, J. Pharm. Chim. [6], 16, 300-301; [6] 16, 371-372; Krause, Ch. Zeitung, 26, 356; Neumann, *ibid.*, 619; Dony, Bull. de la Soc. Chim. de Belgique, 19, 136; C. F. Ribourg, Bull. de l'Assoc. des Chim. de Sucre et Dist., 24, 672; Foerster, Z. f. Elektroch., 14, 3; Classen, *ibid.*, 14, 33; Fischer, *ibid.*, 14, 34; Foerster, *ibid.*, 14, 90; Classen, *ibid.*, 14, 141; Perkin, *ibid.*, 14, 143; Foerster, *ibid.*, 14, 208; Classen, *ibid.*, 14, 239; Stähler, Ch. Z., 30, 1203; Fischer, Ch. Z., 31, 25.

6. THEORETICAL CONSIDERATIONS.

In the following pages, forms of apparatus and their arrangement in carrying out metal determinations will be carefully considered. As the details for estimations and separations will be amply given, and electrolytes of various descriptions will be suggested, a preliminary section may be here introduced, in which will be set forth some of the views entertained, at present, for the different behavior of metals in electrolytes which have met with widest use.

It is due Kiliani (1883) to say that he showed by attention to differences in decomposition pressure, how the separation of metals could be readily made in the electrolytic way. He used pressures corresponding closely to the thermal values of the salts undergoing electrolysis.

Uncertainty prevailed as to whether the precipitation of a metal first began when a definite pressure was reached, or whether it took place with the very lowest pressure and gradually advanced to the maximum. On this point Kiliani's study gave no decisive answer.

In 1891, Le Blanc (*Z. f. ph. Ch.*, 8, 299) conclusively demonstrated that every electrolyte, under normal conditions, showed a decomposition-pressure peculiar to it, and that this pressure might be accurately determined.

Freudenberg, guided by these facts (*Z. f. ph. Ch.*, 12, 97), classified the metals as follows:

1. Those which, by proper pressure, cannot be separated from aqueous solutions: the alkali metals, the alkaline earth metals, etc.

2. Those generally precipitated on the anode by the current in the form of peroxides: lead, manganese, and thallium.

3. Those deposited in metallic form upon the cathode.

These three groups may be easily separated. In this instance, electromotive force (pressure) has little significance.

But Freudenberg observed:

“The third or last group may be separated into sub-groups, easily separable one from the other, the important point being the magnitude of their discharge potential in comparison with that of hydrogen.

“According to Le Blanc the decomposition value of all acids and bases reaches its maximum at 1.7 volts. This is due to the fact that at this point the ions of water can discharge themselves. Therefore, all those metals whose salt solutions cannot be decomposed till the pressure exceeds 1.7 volts, must

have a greater electric cohesion than the hydrogen of water. Since then, in electrolysis, those ions will be first deprived of their charge, which require the least expenditure of energy to accomplish this, the metals of the last group will not be precipitated from solutions in which the hydrogen ions, in proportion to the current density, are present in excess. This end is reached by the presence of strong acids, *e. g.*, nitric acid. Weak acids will not answer, because the concentration of hydrogen ions in them is too slight.

“Alkalies and alkali salts cannot exercise any influence upon the precipitation of metals. This is because the alkali metal in them plays the rôle of a cation and is therefore not to be considered in the discharge. The most important metals, which show in their salt solutions a more ready decomposability than the corresponding acids, are gold, platinum, silver, mercury, copper, bismuth, antimony, arsenic and tin. As previously mentioned, the ratio of their decomposition values (being independent of the anion) will be the same in all cases, if there is only present in the solutions a sufficient number of metal ions. This condition is almost invariably realized; because, as a rule, metallic salts are strongly dissociated. The condition, however, is not met when dealing with complex salts. And it is especially true in the case of the metal double cyanides; *e. g.*, potassium copper cyanide. Its formula indicates it to be the potassium salt of hydro-cupro-cyanic acid. If this salt were absolutely complex, then it could only contain ions of CuCy_4 and potassium. Upon electrolysis CuCy_4 would pass to the anode and potassium to the cathode. A precipitation of copper could not occur. As a matter of fact, however, this double cyanide, like its analogues of the other heavy metals, is not a perfect complex, but in aqueous solution is slightly resolved into copper cyanide and potassium cyanide, which are further dissociated into their components. Hence, copper ions must be assumed as present in the solution of

potassium copper cyanide; but they are so few in number that their presence cannot be chemically demonstrated. In other double cyanides, *e. g.*, that of silver, the degree of dissociation is sufficient to render possible a chemical test for silver ions. There is then a gradual transition from complex salts to double salts. The best means of distinguishing between these two classes of bodies is their electric behavior. This is so because (the most important consideration) they influence characteristically the pressure necessary for the separation of the metal in them. According to a theory proposed by Nernst (*Z. f. ph. Ch.*, 4, 129) the potential difference of a solid metal in contrast to a liquid is dependent not only upon its solution-tension, but also upon the concentration of the ions present in the solution; it increases with increasing dilution. Just as a solid in contrast with a liquid shows a greater tendency to dissolve, the less of it there already is in solution (the less in consequence is the opposing osmotic pressure), so a metal in contrast to a liquid shows a greater difference in potential the fewer ions there are of it in the latter. Conversely, the electromotive force intended to throw out the metal ions in solution must, therefore, be chosen larger in proportion, as it is less supported or aided by the osmotic pressure of the same, and the less also the concentration of the ions. It must become endless if the number of ions is infinitely small. Therefore, theoretically speaking, metals can never be completely precipitated from their solutions by the galvanic current. Yet, as seen from the formula of Nernst, under normal conditions, the rise in polarization with dilution is so very slow that in practical work it is negligible. In the complex cyanides, however, the number of metallic ions is so extremely small that they are capable of very appreciably influencing the difference in potential requisite for their separation. The degree of this influence depends, in addition to the specific property of the double cyanide, upon the quantity

of potassium cyanide present in the solution, inasmuch as the presence of the latter retards the dissociation of the metallic cyanide. Further, the water may show an abnormal rise of polarization in consequence of the small number of its ions. In neutral salts, not having ions similar to those of water, its decomposition value is about 2.2 volts, because of the formation of base and acid at the electrodes. Acids and alkalies, however, show normal pressure. In their electrolysis, unlike that of the alkali salts, concentration changes alone occur at the electrodes. It is therefore important with the double cyanides, in whose solutions the higher decomposition value of water (2.2 volts) comes into consideration, whether in them the abnormal potential of the metals is able to raise itself above that of water, or whether it remains below. If the first be the case, by regulated pressure, the hydrogen alone will be discharged and the metal cannot be precipitated. The number of hydrogen ions is, indeed, very small, but as the number of the metal ions is also extremely small, therefore the separation of the former is favored in consequence of their lower potential.

“Precipitation under these conditions becomes possible only by using, on the one hand, a higher pressure and sufficient current density, or, upon the other hand, by decomposing the potassium cyanide present, thus lowering the potential of the metal which it is desired to precipitate.

“Another group of metals, namely, those sufficiently dissociated in their double cyanide solutions, are not able to raise their potential above that of hydrogen, hence they can at once be precipitated from a potassium cyanide solution.

“The earlier view by which the metals were regarded as a secondary precipitation, caused by the potassium set free by electrolysis, leads to contradictions. For example, it does not well explain why the current precipitates some metals readily from solutions containing an excess of potassium cyanide,

and others only with difficulty. If it be a fact that potassium is discharged and it is then in a condition to produce a secondary reaction, why does it act in this manner with certain metals and not with the others? Further, the intimate connection, existing between the precipitation of metals and their chemical detection by hydrogen sulphide, argues most clearly in favor of the first theory.

“This variation in the behavior of metals in potassium cyanide solutions leads to another division, which rests upon entirely different principles, not identical with those answering for acid solutions. Metals readily reduced from a potassium cyanide solution are gold, silver, mercury and cadmium. Examples of the opposite class are copper, platinum, arsenic, nickel, cobalt, iron and zinc. It is worthy of note how the potential of metals, originally constant in consequence of the specific cohesion of the ions, may be increased at will and altered in its order of magnitude by diminishing the number of ions.

“There is another instance, besides the double cyanides, which has found practical application and is explainable by this same principle. Certain metals, *e. g.*, arsenic and antimony, able to act both as bases and acids, may be more or less completely robbed of their ionic condition by dissolving them in alkalies, thus imparting to them the rôle of an acid. Thereby their potential rises above that of hydrogen in a manner perfectly analogous to that of the double cyanides, and they are then no longer reducible by the current.

“At this point may be recalled the fact which well represents the behavior of the metals upon electrolysis—it is the great analogy between their precipitation by the galvanic current and by hydrogen sulphide. The cause for this is that the tendency of metals and hydrogen to form ions in general repeats itself in their sulphur derivatives. In a solution containing an excess of hydrogen ions there will be just

as few metals precipitated by hydrogen sulphide as by the current if the ionizing tendency of the metals is greater than that of hydrogen. In an alkaline solution, in which the ionizing tendency of the hydrogen attains an abnormal value, all those metals will be precipitated both by the current and by hydrogen sulphide, whose ionizing tendency is lower than that of hydrogen. Finally, in a potassium cyanide solution, in which the potential has been greatly increased, only those metals will be precipitated by hydrogen sulphide which are immediately precipitated by the current. True, the analogy between the two series is not absolute in any sense. Thus, hydrogen sulphide precipitates cadmium from a solution containing nitric acid, but this is not the case with the current. But it follows it in so far that in metallic mixtures, hydrogen sulphide, as well as the current, causes a partial precipitation. In slightly acid solutions, hydrogen sulphide precipitates cadmium at once; should, however, copper be simultaneously present in the solution, at first this metal only will be precipitated, and not until the major portion of it has been thrown out of solution will any cadmium appear. Could, therefore, the action of hydrogen sulphide be regulated as the current is regulated, a separation of the two metals might be possible in this way.

“The behavior of metals contrasted with that of hydrogen in reference to their potential in different solvents made possible the simplest separations, and the early methods were almost exclusively based on this fact. Because the maintenance of a definite pressure was not necessary, it is natural that it should not occur that it was important, hence it was almost wholly ignored. Formerly, in most precipitations, equal voltage was used, and the current strength was regulated in accordance with the influence exerted by the gas evolution upon the deposit. This was done by the introduction or removal of resistances. Under particularly favorable con-

ditions, by this means alone, metal separations were effected. The current density was so low that the ions of the more readily reducible metal continued to the end to take upon themselves the discharge of electricity, so that only after the removal of the same was it possible for the second metal to participate in the electrolysis. It is, however, in every respect more practicable to lower the current density, not by increasing the external resistance but by lowering the pressure, because in this way is not only the precipitation of the second metal prevented, but the current density may be allowed to increase appreciably more than by the former procedure. Only arrange the pressure so that it exceeds enough the polarization of the one metal while it continues below that of the other. A reliable separation of metals may be attained in this manner independently of the length of action of the current.

“It is obvious that the importance given the pressure, by use of this method, in contrast to current density must lead to many alterations in regard to method and apparatus in electrolysis. First of all, the oxy-hydrogen voltameter, which heretofore has afforded us information regarding the current energy employed, will lose its importance as a measuring instrument, etc.”

Bancroft (Internationaler Congress (1903), Band 4, 703), commenting upon the separation of metals by attention to their difference in pressure, adds:

“As a matter of fact, this method is not used in most of the standard separations which are rather to be classed as constant current separations, even though the current may not be held absolutely constant. In order to prevent the second metal precipitating as soon as the first is all down, it is essential that hydrogen shall be set free by the current instead of the second metal. The essential feature, therefore, of a constant current separation is that the decomposition voltage for hydrogen in any solution shall lie below the decomposition

voltage of one of the two metals. Since most separations were originally made without a voltameter in circuit, no satisfactory results were obtained until a solution was found which permitted of a constant current separation, and, for this reason, all, except some of the most recent separations, are constant current separations."

Root (Jr. phys. Ch. (1903), 7, 428), under the direction of Bancroft, studied the conditions of a number of metal separations from solutions of cyanides, oxalates, phosphates, and tartrates. The tables below and on p. 39 give most of the important separations for silver, mercury, copper, bismuth, lead, tin, nickel, iron, cadmium and zinc.

"The first column gives the metal and the second the solution. In the third column C means that a constant current separation is used and V a voltage separation. In the fourth column the same letters refer to the method of separation as predicted from measurements of decomposition voltage.

"As was to have been expected, practically all the determinations are constant current separations, and the few that are not are of minor importance."

TABLE I.

TABLE II.

SILVER OR MERCURY FROM				COPPER FROM			
Cu	Nitric acid	V	V	Bi	Cyanide + citrate	C	C
	Cyanide	C	C		bismuth precipitates		
Bi	Nitric acid	V	V	Pb	Excess nitric acid	C	C
Pb	Excess nitric acid	C	C	Sn	NH ₃ + tartrate	C	C
Sn	Sulphide (Ag ₂ S insoluble)			Fe	Acid, phosphate, or oxalate	C	C
Fe	Nitric acid	C	C	Ni	Acid, phosphate	C	C
	Cyanide	C	C		Oxalate	V?	C
Ni	Acid	C	C	Cd	Acid	V?	C
	Cyanide	C	C		Phosphate	C	C
Cd	Nitric acid	C	C		Cyanide		
	Cyanide	V?	C		cadmium precipitates	C	C
Zn	Cyanide	C	C	Zn	Acid, phosphate	C	C

TABLE III.

BISMUTH FROM			
Pb	None		
Sn	NH ₃ + tartrate	C	C
Fe	Acid sulphate	C	C
Ni	Acid sulphate	C	C
Cd	Acid	C	C
Zn	Acid	C	C

TABLE IV.

IRON FROM			
Ni	None		
Cd	Alkaline cyanide cadmium precipitates		C C
	Acid (NH ₄) ₂ SO ₄ cadmium precipitates		C C
	Phosphate, cadmium precipitates		C C
Zn	Alkaline cyanide, zinc precipitates		C C

TABLE V.

NICKEL FROM			
Cd	Alkaline cyanide cadmium precipitates		
	Acid (NH ₄) ₂ SO ₄ , cadmium precipitates	C	C
Zn	NaOH + tartrate, zinc precipitates	C	C

TABLE VI.

CADMIUM FROM			
Zn	Sulphate	C	C
	Cyanide	C	C
	Phosphate	C	C
	Oxalate	C	V?

A most interesting contribution, along this same line, has been made by Danneel (Internationaler Congress für angew. Ch. (1903), 4 Band, 680-687). Consult also Hollard, Ch. N., 87, 193; 88, 5; 89, 110, 125; Zentralblatt, I. (1903), 600. See, further, F. Foerster, Z. f. ang. Ch., 19 (1906), 1842-1849. *Ibid.*, 29, 1889. Gillett, Jr. phys. Ch., 13, 336.

7. THE RAPID PRECIPITATION OF METALS IN THE ELECTROLYTIC WAY.

While engaged in perfecting old and seeking new electro-methods, the writer, watching the precipitation of molyb-

denum in its electrolytic separation from tungsten, observed delicate, blue-colored, thread-like masses extending, or reaching out, from the cathode toward the anode—a flat platinum spiral—which, as they approached the latter, immediately vanished. These threads of a blue-colored tungsten oxide, formed in the vicinity of the cathode by reduction, were re-oxidized upon coming into the field of oxidation surrounding the anode. Immediately the thought suggested itself that by agitating the electrolyte the unwished-for reduction of the tungstic acid would not take place. Then arose the question as to how this might best be done. The passage of an air current did not, for numerous reasons, recommend itself, so that the next thought was *to rotate the anode*. This was tried. All this occurred in 1901. The results were disappointing. But on applying the idea in the same year to other metals, it was soon found that copper, silver and mercury were precipitated in excellent form, and further, that by causing *the anode to rotate at a high speed, greater current intensity and higher voltage* might be applied with an attending, more rapid precipitation of the respective metals. The time period was astonishingly reduced. The results were carefully noted, but the earlier question of the separation of molybdenum from tungsten continued to persistently obtrude itself. Hoping to solve it, further work with copper and other metals along the lines just described was interrupted and not resumed, except at short intervals in 1902, until early in 1903, when the writer directed Dr. Franz F. Exner, then a student in this laboratory, to repeat the experiments upon the metals, *rotating the anode while applying currents of great intensity and high voltage*. The results of these trials were embodied in Exner's doctoral thesis published in June, 1903, and in condensed form in the *Journal of the American Chemical Society*, Vol. 25, 896. They were of such a remarkable character that many chemists considered the field of electro-analysis to have been truly

revolutionized by them. In the opinion of the writer, they represent at least a new departure in this domain. Metals (in quantities, from 0.1 to 0.2 gram.) which, until this study was completed, were determined electrolytically under the most favorable circumstances (from 0.1 to 0.2 grams) in periods from two to four hours are now estimated in quantities varying from 0.25 to 0.5 gram and more in from five to ten minutes. But before discussing minutely these results of Exner and those obtained along similar lines by other students of the writer, it is proposed to sketch briefly the allied efforts of other chemists along similar lines.

The fact that agitation of the electrolyte favors the electro-deposition of metals has long been recognized in the great technical field of electrolysis. For some mysterious reason it has not impressed itself very strongly upon the minds of analysts, although it is only just and proper to record that v. Klobukow (J. pr. Ch., 33 (Neue Folge), 473, 1886) particularly emphasized the importance of agitating the electrolyte during the passage of the current. Indeed, he made this matter his special study, devising various forms of agitators to achieve his ends. He deprecated the blowing of gases through the electrolytes, because it was impossible to distribute them evenly, and the superficial appearance of the bubbles, he thought, exerted a harmful effect upon the metal depositions near the edge of the electrolyte and perhaps occasioned undesirable oxidations. In his efforts to contrive mechanical devices he rotated the cathode and then the anode; indeed, he even held the electrodes stationary while moving the electrolyte itself. At last he declared himself partial to a rotating anode and announced that the results obtained in this way by him in electrolysis were most astonishing. However, those results were never given to the public; so that students were permitted to rely on their imaginations to picture the character of the novelty. v. Klobukow's chief thought was the agita-

tion of the electrolyte. The use of high currents with high speed of rotation of the electrode was not discussed. In his preferred form of apparatus a platinum dish served as the

FIG. 12.

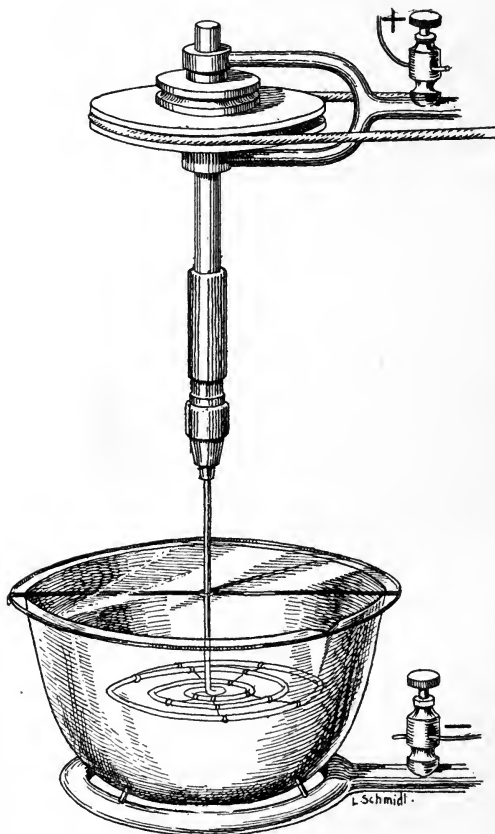

cathode. The anode was attached as shown in Fig. 12. The power was derived from a water motor. The anode performed not more than 150 revolutions per minute. The apparatus is sketched here because historically it holds first place among

the various forms of apparatus devised for agitation in electroanalysis, and too much credit cannot be given to v. Klobukow for it. It is essentially the form employed by the author, by Exner, and others in this laboratory. v. Klobukow used a platinum disk as anode.

Levoir (*Z. f. a. Ch.*, 28, 63), also, appreciated the advantages

FIG. 13.

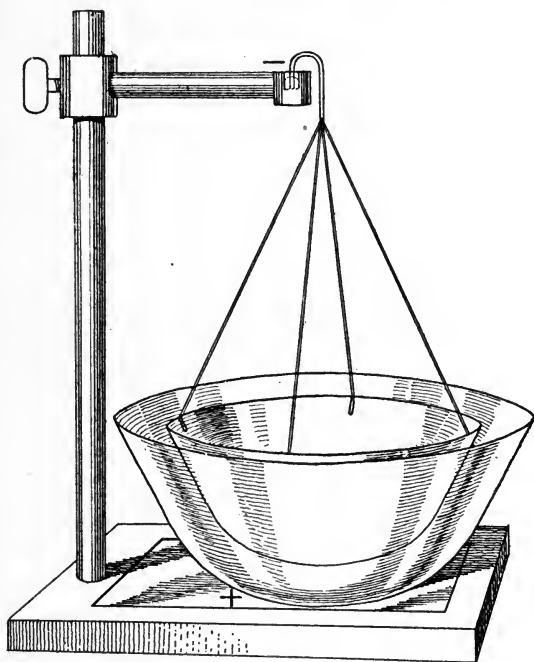

arising from agitation of the electrolyte during the precipitation of metals by the current, for it is to him that we are indebted for the thought represented in the apparatus pictured in Fig. 13. The positive electrode is the larger dish; in it is suspended the smaller dish—the negative electrode. By this arrangement it is expected that the electrolyte will be agitated by the oxygen bubbles arising from the positive elec-

trode. v. Klobukow's criticism of Levoir's suggestion was that the requisite energetic liberation of oxygen would not always be attainable in metal precipitations; further, it may not be advisable to have the deposited metal come in contact with oxygen. Unnecessary oxidations in the electrolyte might very easily occur, so that all things considered, it would seem wisest to utilize the positive electrode as an agitator, rotating it slowly about its axis.

So far as the writer's knowledge extends, the idea of Levoir has met with nothing like general adoption in electro-analysis.

The preceding paragraphs contain no reference to the use of high currents and high voltage, which was the dominant idea with the writer and his corps of students when they began in 1901 to rotate the anode in electrolysis. That is, v. Klobukow and Levoir were content to agitate the electrolyte and to stop there. The possibility of using higher intensity of current and greater voltage escaped their thought.

This idea first appeared in print in an article published by Gooch and Medway (*Amer. Jr. of Science* [4th Series], **15**, 320), when they said:

“So far as we are aware, however, no attempts have been made, heretofore, to apply the *rotary cathode*, in analytical operations, in which it is the object to remove the metal completely from solution. In such processes the soluble anode is not used, and the comparatively high electromotive force necessary to overcome the resistance and to throw down the metal with rapidity liberates hydrogen from the water solution simultaneously with the metal, and the consequence is the production of a deposit lacking in compactness and adhesiveness. This interference on the part of the evolved hydrogen with the regularity of deposition appears to be the chief reason why low intensity of current must be used in the ordinary electrolytic processes of analysis. We have made some experiments, therefore, to see whether it is not possible

to so far avoid the interfering action of hydrogen by the use of the revolving cathode as to secure with high currents and in a short time deposits sufficiently adherent and homogeneous for analytical purposes."

The cathode was a platinum crucible of 20 c.c. capacity. It rotated at a speed of from 600 to 800 revolutions a minute. It was driven by an electric motor fastened so that its shaft was vertical (Fig. 14). The crucible was attached to the shaft by pressing it over a rubber stopper bored centrally and fitted tightly on the end of the shaft. "To secure electrical connection between crucible and shaft, a narrow strip of sheet platinum is soldered to the shaft and then bent upward along the sides of the stopper, thus putting the shaft in contact with the inside of the crucible when the last is pressed over the stopper. The shaft is made in two parts as a matter of convenience in removing the crucible and is joined, with care to make a good contact between the two pieces of shafting, by a rubber connector of sufficient thickness to prevent the crucible from wobbling when rotated." A platinum plate was the anode. It dipped in the salt solution contained in the beaker. Copper, silver, and zinc salts were studied in this way. The results were indeed most satisfactory.

It must be remembered that the *cathode* was rotated in these trials, and when their publication was made Exner's experiments were well advanced, results having been obtained, not only with copper, zinc and silver, but with various other metals; so that the writer felt justified in privately communicating to Prof. Gooch the outcome of Exner's work. As the latter used the rotating anode with high current and high pressure, suggested by the writer and Gooch, the rotating cathode, there appeared no good reason why each should not continue to pursue, undisturbed, his own original plan, and this has been done with marked success in both cases.

It was only natural to expect that modifications in forms

of apparatus would soon follow. One of the best suggestions in this direction was that of E. S. Sheppard in the Journal of

FIG. 14.

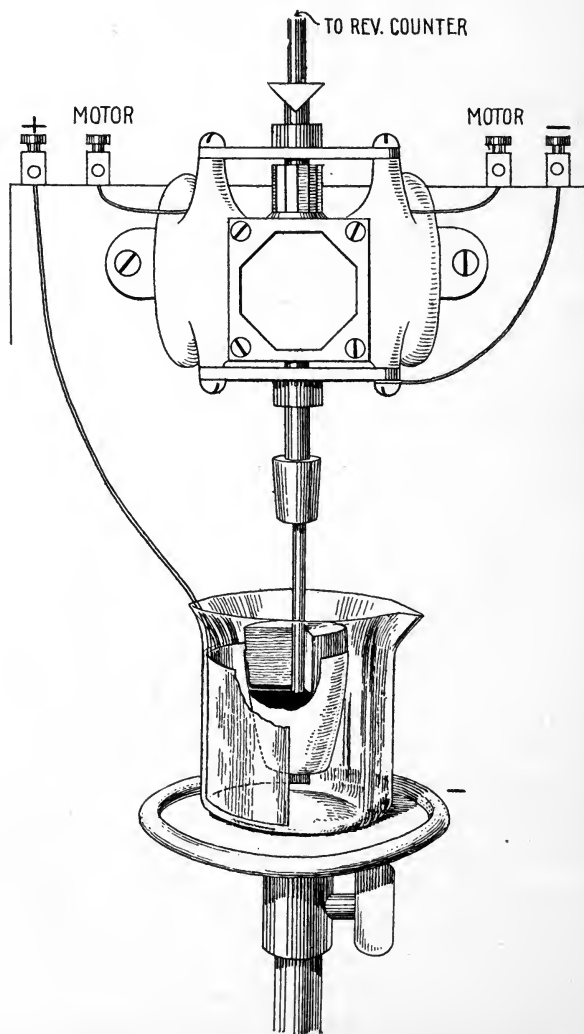

Physical Chemistry, 7, 568. It is used in the Cornell Laboratory (Fig. 15).

“Instead of a platinum crucible, I have used the ordinary disk anode, shortening the stem to about 6 cm., and fastening it by a screw connector directly to the shaft of the armature. The connection to the battery is made through the iron frame of the motor. The motor used is a toy motor, a very poor affair in its way, but sufficient for the purpose and cheap enough to permit each cathode having its own motor. The

FIG. 15.

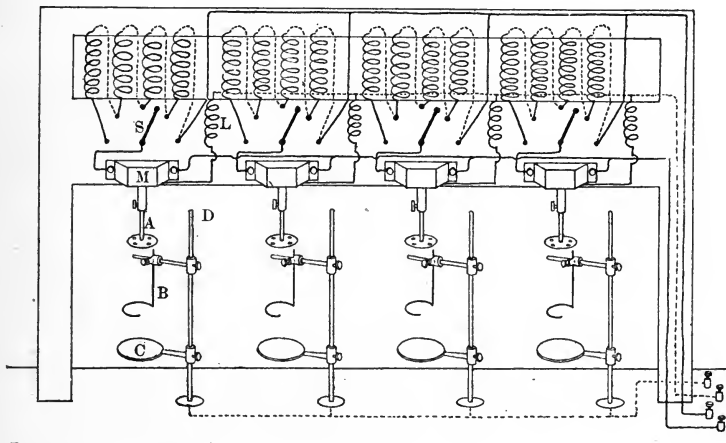

use of belts as suggested by Gooch is very unsatisfactory, owing to the slipping, etc. It was found best to arrange a rheostat for each motor, since no two motors run on the same current, and it is also desirable to slacken the speed when removing the beaker and washing the cathode.

“This rheostat consisted of one zero, two one-ohm and two two-ohm coils connecting through the switch (S); the other motor connection being through the wire leading to M, and a 110-volt circuit lamp may of course replace this form of rheostat.

“The cathode connection was made through four 8-volt 6-C. P. lamps in multiple (L), for storage battery work, or these are replaced by the ordinary 110-lamp for dynamo circuit. The current was then regulated by loosening or tightening the lamps in their sockets. No difficulty was experienced in getting a good connection through the motor frame to the cathode.

“The beaker containing the electrolyte was supported by the wood support (C) on the brass posts (D). The screw for tightening the collar of (C) should be of such a size as to allow manipulating this support with one hand, leaving the other free to manage the wash bottle, etc.

“The anode was a stiff platinum wire held in the usual electrode holder, connection being made through the brass posts (D). The distance from the motors to the base board is about 30 cm., and between the motors, 10 cm.

“The disk electrode was used because we happened to have that form in stock. A more desirable form would be a disk of platinum gauze, thus allowing a stronger current to be used and shortening the time required.

“The brass conductor which connects the cathode to the shaft is protected from corrosion by a rubber tube. A finger stall does very well.”

Very satisfactory determinations of the copper content of chalcopyrite and the zinc content of sphalerite were carried out by means of this device.

F. M. Perkin (*Z. f. Elektroch.*, 10, 477) was also among those who first recognized the advantage in rotating the electrodes while precipitating metals. To him we are indebted for the apparatus pictured in Fig. 16 (*Ch. N.*, 87, 102). It is taken from his *Practical Methods in Electro-Chemistry*. Here:

“The support for the cathode consists of a gun-metal arm, the end of which is drilled to allow a spindle to pass. This spindle carries a small chuck (such as is used in fixing small

drills) which is used for holding the rotator. The grooved pulley, which is fastened on to the upper end of the spindle, bears on the top of the arm, which is ground smooth. The whole arrangement is driven by means of a belt from a water turbine or electric motor. This arrangement is found to give very perfect contact and to work with very little friction. The parts should be only slightly lubricated, the best lubricant being a mixture of graphite and oil.

“The cathode, as is seen from the figure, is a small sand-

FIG. 16.

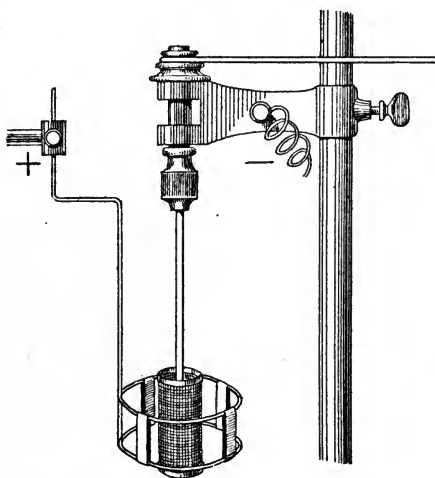

blasted cylinder of platinum gauze which has a combined surface of about 25 cm. The anode is in the form of a double circle of stout platinum wire, and has four little baffles placed at intervals around it, to prevent the liquid from rotating with the cathode. A double coil of stout platinum wire serves equally well. Of course for peroxide deposits the rotating electrode would be the anode. A cylinder of sheet platinum also gives very good results, but in this case very little metal is deposited upon the inner surface. Longitudinal slits, how-

ever, partially get over this difficulty, but with gauze as shown in the figure, the deposition is practically equal inside and outside." In the *Trans. of the Faraday Soc.*, 2, 91 (1906) the same chemist recommends a stationary anode (platinum spiral), fitting into a separatory funnel, while the cathode is rotated. This consists of a spiral, preferably of 20 per cent. platinum-iridium wire, with the plane of each coil in the direction of the axis of the spiral. (See *Ch. N.*, CI., 52.)

See further—Perkin and Hughes, *Trans. Faraday Soc.*, 6, 14; Consult Ashcroft, *Electroch. and Metallurgical In-*

FIG. 17.

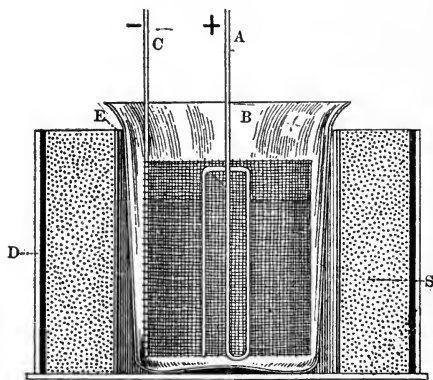

dustry, 4, 145; Frary, *J. Am. Ch. Soc.*, 29, 1592; *Z. f. Angew. Ch.*, 26, 1897; Fischer and Scheen, *Ch. Z.* 34, 477; Acree, *Am. Ch. Jr.*, 35, 313.

Frary in the *Z. f. Elektrochem.* (1907), 23, 308, presents a new form of apparatus (Fig. 17) to be used in the rapid precipitation of metals. A motor is not necessary. No parts of the apparatus are at any time in motion. The parts, given in the vertical section, are the spool (S) wound about a cylinder (E) of thin sheet copper through which passes the electrolyzing current. The cylinder is large enough to conve-

niently accommodate a beaker (B) of 150 c.c. capacity. The spool is surrounded, for practical reasons, with a rather thick cylinder of sheet iron (D), and the entire system placed on a piece of sheet iron in order to augment the magnetic field in the beaker. C is the gauze cathode. A is the anode of platinum wire. The electrolyte must not extend beyond the upper end of the cathode. The spool is made from 1 kilogram of insulated copper wire of 1.1 mm. diameter. Its resistance is about 2 ohms. The cathode may be a cylinder of platinum, silver, or copper gauze. See also L. S. Palmer and R. C. Palmer, *Trans. Am. Electroch. Soc.*, **15**, 489; Alders and Stähler, *Berichte* **42**, 2685.

Frary, using this form of apparatus, precipitated 0.8500 gram of copper from 100 c.c. of a copper sulphate solution, acidulated with ten drops of concentrated sulphuric acid, in fifteen minutes. The current equalled 6 to 7 amperes and the pole pressure was about 6 volts.

R. Amberg (*Z. f. Elektrochem.*, **10**, 853) and Fischer and Boddaert (*ibid.*, 945) write at some length upon the rapid precipitation of metals, although their results were in the main anticipated by previous investigators in this new field.

Stoddard (*Jr. Am. Ch. Soc.*, **31**, 385) contends that rotation of the electrodes is unnecessary and recommends the following course: Use platinum gauze cylinders 3 cm. in diameter and 3 cm. long, with a total surface of about 40 sq. cm., and as anodes cylinders of platinum foil 0.8 cm. in diameter and 2.5 cm. long. During the electrolysis the anodes should be placed concentrically within the cathodes. Make the precipitations in 80 c.c. beakers and with about 50 c.c. of solution. Bend the wires of both electrodes at an angle of somewhat more than 90° so that they may rest on the lip of the beaker and allow a watch-glass cover to be used conveniently. The thought of Stoddard is that the strong currents employed give rise to heat and gas evolution sufficient to agitate the solution.

In the precipitation of a few metals this scheme works well, but the experience in this laboratory has been that most metals will require greater agitation of the electrolyte for their complete and satisfactory deposition. See also Price and Humphreys—Jr. Soc. Ch. Ind., **29**, 307; Price and Hyde (J. Soc. Ch. Ind., **30**, 391).

J. W. Turrentine, Trans. Am. Electroch. Soc., **15**, 505 (1909), and **17**, 303 (1910), proposes the use of graphite cathodes and anodes as substitutes for the more expensive platinum electrodes. When treated as recommended by Turrentine, the graphite serves fairly well for approximately close analyses. Under high current densities, it has a decided porosity and a tendency to flake.

Consult Sherwood and Alleman, J. Am. Ch. Soc., **29**, 1065, upon the use of tin as a cathode for the rapid quantitative electrolytic deposition of zinc, etc. See also Berju, Z. f. Chem. Apparaten K, **2**, 456 (1907); Fairlie and Bone—Electro-Chemical and Metallurg. Industry, vol. **5**, 18. Formanek and Pec. Ch. Z., **33**, 1282.

As minute details in the use of the rotating anode will be given under the various metals, it will not be necessary here to occupy further space for their consideration save to add that Henry Sand (Z. f. Elektrochem., **10**, 452) remarks, in explanation of this rapid precipitation of metals, that "it is most probable the high current densities are possible and dependent solely upon the rapidity of renewal of the liquid at the electrodes. It is extremely likely that in metal precipitation the potential at the cathode is independent of the current density. The great variations observed when applying different current densities are almost wholly the consequence of local concentration changes. The great rôle which such changes, under circumstances, can play, I showed four years ago in the electrolysis of copper sulphate solutions containing sulphuric acid (Z. f. ph. Ch., **35**, 641). Just as long as copper ions, in ap-

preciable concentration, were present at the surface of the touched electrode, those alone were precipitated, when, however, they had practically disappeared from this *touched* surface, all the copper migrating in that direction was, by diffusion, set free simultaneously with the hydrogen. In all instances, as a consequence of local exhaustion of copper sulphate, in spite of the convection, heating, hydrogen evolution, etc., over 60 per cent. of the current was consumed in liberating hydrogen. On agitating the solution energetically, copper alone was precipitated. Had the purpose of these trials been to determine copper, that metal would, in the first instance, have separated in a pulverulent form; in the second, as a coherent precipitate.

“The conditions upon which the local concentration changes at the electrode are dependent are well known and were adequately emphasized by Danneel (*Z. f. Elektrochem.*, **9**, 763). In the mind of the writer of those lines, however, in the mere enumeration of those factors, we fail to place their functions in the true light. Thus, if it be said of diffusion that it acts in opposition to concentration alterations at the electrode, there is, thereby, not expressed the idea that diffusion renders possible current conductivity, and is indissolubly connected with it, and that without diffusion the concentration of a metallic salt at the electrode would fall at once to zero. Such an enumeration also expresses just as little the fact that diffusion alone without convection is never able to completely cancel the alterations in concentration at the electrode.

“The relative function, attaching to the individual factors, may be best represented by an expression for the time which expires until the concentration at the electrode without any convection or artificial disturbance of the liquid falls to zero, or at least diminishes by a definite amount.

“This time period follows immediately from equation 2 in the cited article:

$$t = \frac{(\Delta c)^2 K}{\gamma (1 - n_c)^2 i^2}$$

Here, Δc , is the value to which the concentration of the salts under consideration may fall (for analytical purposes this is always the concentration of the salt); K is the diffusion coefficient of the salt; γ the number $\frac{(1.1284)^2}{96540}$; i the current density and n_c the conversion number of the precipitated metal in the larger sense, *i. e.*, the ratio of the equivalent of metal, directed by the current to the cathode, to the entire number of equivalents carried by the current. In the case of a complex salt, in which the metal wanders from the cathode in the form of an anion, a negative value must be introduced— n_c . In experimenting with a sample of copper sulphate containing free sulphuric acid, it was demonstrated that the expression is sufficiently accurate when a conducting electrolyte is present. It may easily happen that with a given apparatus and with a given rotation velocity, on electrolyzing different solutions with varying current densities satisfactory results will always be obtained if the magnitude given above does not exceed a definite value. The expression, omitting the constant γ , may be viewed as characteristic for the behavior of a solution under electrolysis. It is evident from it how far conducting salts favor decrease in concentration (by reducing n_c), and that in this particular complex formation can act more unfavorably (by the negative value of n_c). It may be further concluded that *ceteris paribus*, at higher concentration of the electrolyte, a proportionately higher current density is admissible than at lower concentration. In fact, in the rapid galvanoplastic methods, solutions are applied in as concentrated form as possible, with little conducting electrolyte. In rapid analysis, by electrolysis, it may, however, be advisable to keep the volume as small as possible and at the same time lower the current strength and have it as nearly proportional as possible with the diminishing average concentration. If the current strength be held constant, in spite of decreasing concentration, then the efficiency of the stirrer should be increased in inverse square ratio to the latter."

See also R. Amberg, *Z. f. Elektrochem.*, 10, 385 and 853; Classen, *Z. f. Elektrochem.*, 13, 181. Wölbling, *Ch. Z.*, 33, 564.

Gooch and Beyer (*Am. Jr. Sc.* [4], 25, 249), while recognizing the excellencies in the modern rapid processes of electroanalysis, have devised several forms of apparatus for the easy and safe handling of electrolytic deposits more or less loose.

"Figure 18 shows a convenient form of apparatus for use in

FIG. 18.

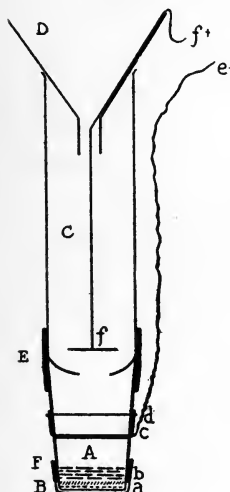
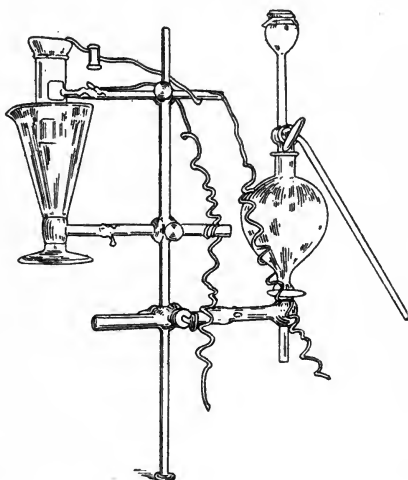

FIG. 19.



electrolytic analysis. The crucible (A), fitted in the usual manner with an asbestos felt (a), serves as an electrode (e) the surface of which is very much increased by a layer of pieces of platinum foil (b) within the crucible and within contact with its walls. The joint between cap and crucible is made water-tight by a thin rubber band (F). The capacity of the cell is made conveniently ample by attaching to the crucible, by means of a close fitting thin rubber band (E), a glass

chamber (C) easily made from a wide short test tube. The second electrode (f) is introduced from above through the glass funnel (D), which serves to prevent spattering of the liquid during the electrolysis, and hangs within the glass chamber. The cell, held by a clamp, may be kept cool during action by immersing it in water contained in a cooler as indicated in Figure 19.

“Electrical connection is made with the crucible by means of a platinum triangle (c) bent as shown and held tightly against the outer wall of the crucible by a rubber band (d). Figure 19 shows, on the left, the apparatus adjusted for work.

“In using the apparatus, the crucible fitted with asbestos and containing clippings of platinum foil, is capped, ignited, and weighed. The glass chamber with the wide rubber band folded back against itself is set upon the crucible and the band is snapped into place. The other adjustments are made in the manner shown. The electrolyte is introduced and the current turned on. After the expiration of time enough to complete the electrolysis, the cooler is lowered and arrangements are made to draw off the liquid in the cell. If the process is such that no harm can follow the stopping of the current before removing the liquid, the upper electrode and funnel are washed and removed, the cap and band are slipped off, and the apparatus is set in the holder of the filtering flask, as for an ordinary filtration. The liquid is drawn through the felt to the flask, the chamber washed down and removed from the crucible, and the deposit is well washed. The crucible and contents are dried and weighed, the increase over the original weight being, of course, the weight of the deposit.

“Copper sulphate strongly acidulated with sulphuric acid was the electrolyte. Deposition was completed and the ferrocyanide test applied to the whole filtrate showed the absence of copper in every case. The apparatus and deposit were washed first with water and finally with alcohol. It was

noticed that though the filtrate contained no copper, the washings did sometimes contain a bare trace. When the filtrate was allowed to stand after treatment with potassium ferrocyanide it turned blue rapidly, and this action, which indicated probably the presence of hydrogen dioxide or of persulphuric acid produced in the electrolysis of the sulphuric acid, is suggestive that the liquid should be drawn from the deposit as quickly as may be after the current is cut off.

“Obviously this process of electrolytic analysis is fairly rapid, easily executed, and accurate; but the desirability of quickly removing the liquid from the deposit after stopping the current is evident.

“In the second process the filtration was effected by removing the cooler, taking off the cap and band from the crucible, and quickly swinging into place the filtration apparatus shown at the right in Figure 19. The liquid was then drawn through the crucible and replaced by wash water until the current ceased to flow because there was no electrolyte to carry it. The apparatus was washed with water and finally with alcohol, and the crucible and contents were dried for periods of ten minutes at 100° - 110° , to constant weight.

“In the third process when a deposit is so loosely adherent as to be moved by the liquid it may be compacted upon the filtering felt by keeping the liquid in process of filtration and constant motion through the cell to the receiver. The adjustment of apparatus for this purpose is shown in Figure 20.

“Here the electrolytic cell rests in the crucible holder fitted to a separating funnel used as a receiver and connected into the vacuum pump. A stop-cock in the tube of the crucible holder is convenient but not necessary.

“The manner of using the apparatus is simple. First, the weighed crucible, fitted in the usual manner with an asbestos felt and containing the platinum clippings, is adjusted to the glass chamber. The cell is pressed into the platinum triangle

and set into the holder. The funnel which carries the wire electrode is put in place. The cell is charged with the electrolyte and the current is turned on. The electrolysis begins, and, under regulated action of the vacuum pump, the liquid is drawn through to the receiver at a convenient rate. Usually, before the upper electrode is uncovered, the stop-cock is closed, the suction pump disconnected, and the liquid drawn off from the receiver and returned to the electrolytic cell.

FIG. 20.

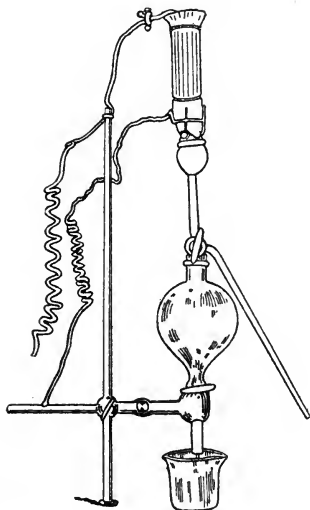
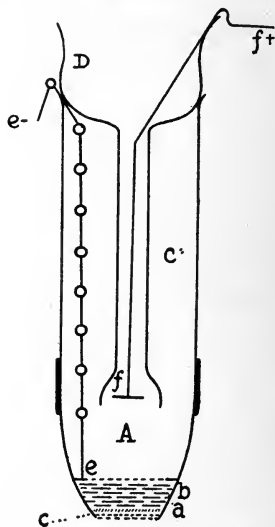

FIG. 21.



The pump is again connected, the stop-cock is opened, and filtration begins again.

“Should the deposit be noticeably loose, it may be compacted by allowing the cell to drain complete under the action of the suction pump. The electrolyte is thus kept in circulation, and loose particles of the deposit are held upon the filtering layer. From time to time, the process of emptying the receiver and filling the cell is repeated. When the electrolysis

is complete, as shown by proper testing of the filtrate, the liquid is drawn through the crucible and replaced by water from above until the current no longer flows. The electrodes are disconnected, the extension chamber easily slipped off, and the washing of the crucible and its contents continued sufficiently, with care, should the deposit be spongy, to give time enough in the washing, to properly soak out absorbed material. The crucible and contents are dried, ignited, and weighed as usual. This method of manipulation was also put to the test in the electrolysis of copper sulphate.

“Another form of apparatus, in which a porcelain filtering crucible replaces the platinum filter crucible, is shown in Figure 21.

“In this apparatus, it is necessary to make the connection from above with the electrode inside the crucible, and this is accomplished by a linked platinum wire. In putting together and using this apparatus, a finely perforated disc of platinum foil (c) is laid upon the more coarsely perforated bottom of the porcelain crucible (A). Upon this disc, the asbestos felt (a) is deposited in the usual manner. Platinum clippings (b) form a layer of suitable thickness above the asbestos, and upon this layer and in contact with it, is placed another perforated disc of platinum foil to which is attached a twisted wire (e) so linked that it may be folded within the crucible. This apparatus is ignited and weighed, and to it is adjusted, as shown, a chamber to hold the electrolyte. The other electrode (f), enclosed within a funnel (D) made from a thistle tube, is introduced in the manner indicated. This apparatus is adapted only to use in the method of continuous filtration, and it is used exactly as in the third process.

“By either of the processes described, reasonably rapid and accurate electrolytic determinations may be made without the use of rotating motors or special stirring apparatus, and with-

out large and expensive apparatus of platinum. The use of the filtering crucible as a part of the electrolytic cell makes possible the utilization of operations and conditions in which the deposit may lack the degree of adhesiveness necessary in ordinary electrolytic processes; and it is hoped, therefore, that the device may extend the range of electrolytic analysis."

8. USE OF A MERCURY CATHODE.

LITERATURE.—*J. Am. Ch. S.*, **25**, 884; *Fillipo*, *Chem. Weekblad*, **6**, 226; *Kimly*, *Jr. Am. Ch. Soc.*, **32**, 137.

Most work in electro-analysis has been performed with platinum cathodes. These have had a variety of shapes: dishes, cones, cylinders, gauzes, etc. Wolcott Gibbs (1880) (p. 27) first suggested the possibility of using metallic mercury as a cathode. He recommended weighing out in a small beaker a definite amount of metallic mercury which was, by means of a platinum wire, connected with a battery and made the cathode; while in the salt solution, contained in the beaker, was suspended a strip of platinum, serving as the anode. The currents used varied greatly in strength.

Three years later (1883), the same chemist (*Am. Ch. Jr.*, **13**, 571) again directed attention to "the employment of mercury as negative electrode, the positive electrode being a plate of platinum. . . . It was found possible to separate iron, cobalt, nickel, zinc, cadmium, and copper so completely from solutions of the respective sulphates that no trace of metal could be detected in the liquid . . . the author had in view both the determination of the metal by the increase in weight of the mercury, and in particular cases of the molecule combined with the metal, either by direct titration or by known gravimetric methods (p. 27)." The experiments were purely qualitative, such being, in the author's opinion, sufficient to establish the correctness of the principle involved.

In 1886, Luckow (*Chemiker-Zeitung*, **9**, 338, and *Z. a. Ch.*, **25**, 113), cognizant of the difficulties attending the determination of zinc in the electrolytic way, described a course (p. 28) for this purpose which consisted in weighing out in a platinum dish a quantity of metallic mercury or its oxide, introducing the zinc salt solution and then electrolyzing, when the zinc, combined with the mercury, spread over the inner surface of the dish as a beautiful, adherent amalgam.

Nothing further was done towards developing the preceding ideas until 1891, when Vortmann (*Ber.*, **24**, 2749) described at considerable length, the determination of several metals in the form of amalgams. His plan consisted in adding a weighed quantity of mercuric chloride to the solution of the salt to be electrolyzed, the metals being then precipitated together. The results were quite interesting and seemed to offer decided advantages, but later experience demonstrated that, except in a few cases, this method of analysis, as elaborated by Vortmann, was in nowise superior to the usual procedure in determining metals electrolytically.

A few months later, in the same year (1891), Drown and McKenna (*Jr. An. Ch.*, **5**, 627), striving to find a method suitable for the estimation of small amounts of aluminium in the presence of a preponderance of iron (p. 145), had recourse to the suggestion of Wolcott Gibbs. They accordingly weighed a beaker containing a layer of mercury (the cathode), and introduced into the solution of the metals a platinum plate (the anode). The current was allowed to act through the night and the iron was completely precipitated in the mercury. Several difficulties were encountered in pursuing this course. The platinum wire projecting into the mercury often had iron precipitated upon it, so that it became necessary to weigh the wire, enclosed in a glass tube, together with the beaker containing the mercury. Further,

much annoyance was experienced in the efforts to dry the amalgam and obtain constant weights.

The thought of the writer had many times dwelt upon the facts just mentioned, until at length it was determined to conduct a series of experiments with mercury as cathode to establish two points: (a) The determination of the negative radical in various salts, as well as the metals combined with them, and (b) the possibility of effecting the separation of certain metals.

To this end, practically the same device as that used by Drown and McKenna was adopted. Into the mercury, serving as cathode, there extended a glass tube from the lower end of which projected a carbon pencil, 1 mm. in length. This pencil of carbon was preferable to the platinum wire; metals did not adhere to it; and, therefore, it was not necessary to weigh it together with the beaker and the mercury. The glass tube was nearly full of mercury, into which dipped a copper wire connected with the negative binding-post. Such was the form of apparatus first used, and the results obtained were quite satisfactory, although difficulty was experienced in drying the amalgam (*J. Am. Ch. S.*, 25, 885). It seemed at the beginning that this might prove detrimental to the general adoption of the method in ordinary analysis. It was, however, successfully overcome, for it was found that the amalgam could be washed with alcohol and ether, thus removing the final traces of water, and that not more than fifteen minutes would then be necessary for the drying of the metal. A number of carefully conducted tests established this point. In the meantime, William M. Howard of this laboratory devised the following form of apparatus to eliminate the use of the anode of Drown and McKenna, as well as the carbon pencil.

It is an extremely simple contrivance, consisting of a small beaker (50 c.c. capacity), (Fig. 22), near the bottom of which

there is introduced, through the side, a thin platinum wire. Internally it dips into the mercury, while externally it touches

FIG. 22.

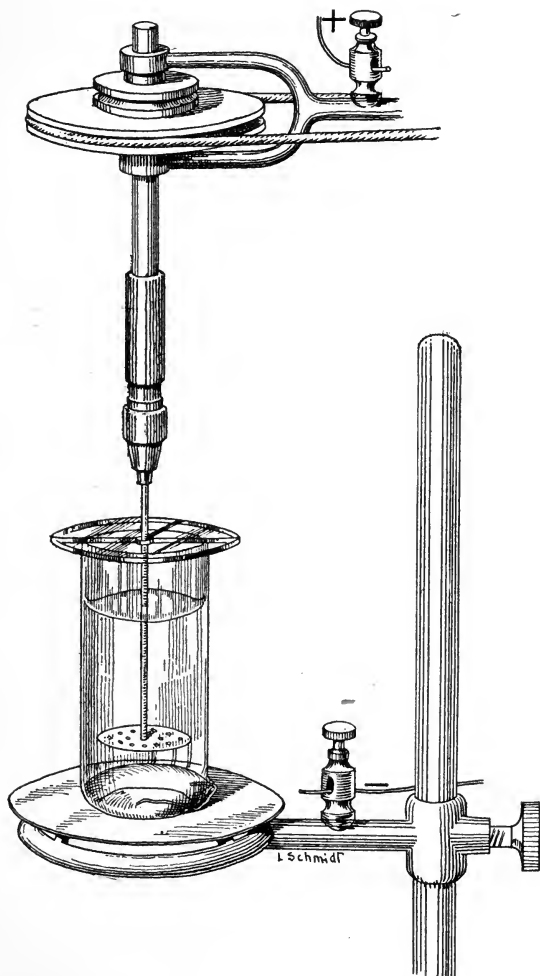

a disk of sheet-copper on which the beaker rests and which is connected with the negative electrode of a cell, thus making

the mercury the cathode. By adopting this device and by washing the amalgam with alcohol and ether, the two chief disturbing factors were removed.

How this device was applied will be indicated under the several metals. Its modifications and uses in the determination of anions will be sufficiently outlined in connection with this special chapter on electro-analysis.

FIG. 23.

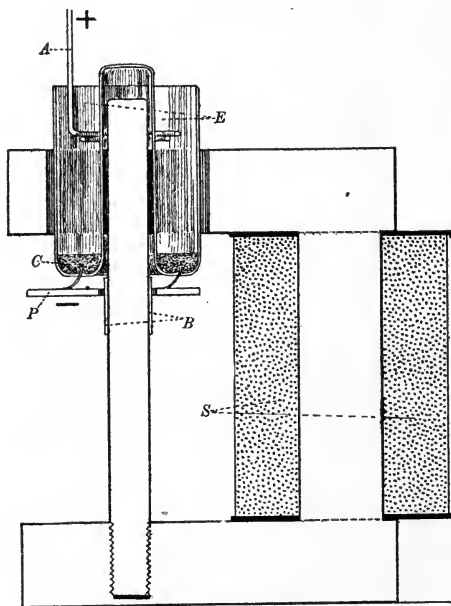

Another device (Fig. 23), for use with the mercury cathode, consists of a U-shaped electromagnet, the spool (*S*) of which is wound about the bend of the magnet. In the upper limb (pole) of the magnet is an opening 4 cm. in width, through the middle of which passes an iron rod, one centimeter in diameter, leading to the other pole, into which it is screwed. The electrolyzing vessel (*E*) is ring-shaped and fits into the opening

between the ring-shaped end of the upper hole and the iron rod. *A* is the ring-shaped anode of platinum wire. *C* is the mercury cathode, forming contact with the copper plate (*P*) by means of the two platinum wires. *B* is a shield of asbestos, designed to prevent contact between the plate and the iron rod.

In the first apparatus (Fig. 17) there is a vertical magnetic field with radial current lines, while in the second (Fig. 23) there is a radial field with vertical current lines. The agitation or movement is particularly energetic in this apparatus, because of the iron core and the very narrow air space. One-tenth of a gram of iron was precipitated from ferrous sulphate in ten minutes, using a current of 4 amperes.

Various communications have appeared from time to time with reference to the use of the mercury cathode. Some are averse to it, while others approve it, offering at the same time modifications in the form of apparatus (Böttger, Ber., **42** (1909), 1824; Price and Judge, Trans. Faraday Soc., **2**, 85 (1906); Porter and Frary, Z. f. angew. Ch., **22**, 166, 167 (1909); Perdue and Hulett, Jr. Phys. Ch., **15** (1910), 147; Alders and Stähler, Berichte, **42**, 2685; A. Beyer, Dissertation, Dresden, 1909; Price, Z. f. Elektroch., **14**, 3; Parker and Frary, Z. f. Elektroch., **15**, 240; Stoddard, Jr. Am. Ch. Soc., **31**, 385).

Daily experience in the use of the cup with its mercury cathode (Fig. 22) on the part of experienced and inexperienced persons has only increased our opinion of its fitness and reliability. It is absolutely necessary that the operator should use it with judgment. An observance of the following points will be helpful (Trans. Am. Electroch. Soc., **14**, 59). It is essential that the cup in which the decomposition occurs should be clean. After use and after removal of the mercury the cup should be washed with nitric acid to thoroughly cleanse it from the amalgam which may adhere to the platinum wire or to the glass in the vicinity of the wire. It is next rinsed

with water and then washed with chromic acid, followed by water, alcohol and ether. Wipe the outside of the cup, but do not touch the inside with the towel or with the fingers. The cup may be dried in a copper oven, or the ether may simply be allowed to evaporate, and the cup then placed in a desiccator ready to be used. Keep 100 c.c. of pure mercury, previously washed with absolute alcohol and ether, in a desiccator to be drawn upon as occasion may demand. Fifty to sixty grams are introduced into each cup, and this portion will serve for a number of determinations. Remove with a camel's-hair brush or a feather, any minute globules of mercury adhering to the outside of the cup or around the rim. Cover the cup containing the mercury, after weighing, with a small watch crystal. Never move or carry the cup without this cover. After introducing the electrolyte by means of a pipette, and making proper dilution, place the cup on a copper plate connected with the cathode, and raise the whole to a proper position with respect to the anode. Place the cover glasses over the cup, cause the anode to rotate, and let the current pass through the electrolyte. Toward the end of the decomposition wash the cover glasses and sides of the tube with a stream of water from a wash bottle. The condensation of the steam, when the current is high, is sufficient to remove all of the electrolyte which may have been carried to the sides or the top of the cup by rotation or by the escaping gases.

When the decomposition is completed, stop the motor, remove the cover glasses, pour distilled water into the cup from a wash bottle, and siphon out the liquid until the level almost reaches the spiral portion of the anode. Then refill the cup and repeat the operation until the current falls to zero—that is, until practically all of the acid solution has been removed. As much as 300 c.c. of water are used for the purpose. Now interrupt the current. That the acid liquid must be removed before the current is broken is a precaution

which must be observed, otherwise the acid will act upon the amalgam and cause a re-solution of the deposited metal.

Next remove the cup and pour off the greater part of the remaining liquid by inclining the tube to the horizontal position. Do not permit the amalgam to come to the edge of the cup or in contact with the finger which is held at the top of the cup in order to hold it more firmly. The cup must then be brought back carefully to a vertical position, and about 10 c.c. of absolute alcohol poured in it. Rotate the cup, after it has been inclined to an angle of 45° , in order that the entire mass of mercury may be brought in contact with the alcohol. The greater part of the alcohol is then allowed to flow. Repeat this operation with a second portion of alcohol, then with two portions of anhydrous ether.

Let the cup, after the last washing with ether, stand for a few minutes until the greater part of the ether has evaporated, then place it in a desiccator. A vacuum desiccator was not found necessary. Any trace of ether remaining may be eliminated by gently twirling (rotating) the cup at an angle of 45° .

SPECIAL PART.

I. DETERMINATION OF THE DIFFERENT METALS.

COPPER.

LITERATURE.—Gibbs, Z. f. a. Ch., 3, 334; Boisbaudran, B. s. Ch. Paris (1867), 468; Merrick, Am. Ch., 2, 136; Wrightson, Z. f. a. Ch., 15, 299; Herpin, Z. f. a. Ch., 15, 335; Moniteur Scientifique [3 ser.], 5, 41; Ohl, Z. f. a. Ch., 18, 523; Classen, Ber., 14, 1622, 1627; Classen and v. Reiss, Z. f. a. Ch., 24, 246; 25, 113; Hampe, Berg-Hütt. Z., 21, 220; Riché, Z. f. a. Ch., 21, 116; Makintosh, Am. Ch. Jr., 3, 354; Rüdorff, Ber., 21, 3050; Z. f. ang. Ch., 1892, p. 5; Luckow, Z. f. a. Ch., 8, 23; Warwick, Z. f. anorg. Ch., 1, 285; Smith, Am. Ch. Jr., 12, 329; Croasdale, Jr. An. Ch., 5, 133; Foote, Am. Ch. Jr., 6, 333; G. H. Meeker, Jr. An. Ch., 6, 267; Classen, Ber., 27, 2060; Heidenreich, Ber., 29, 1585; Regelsberger, Z. f. ang. Ch., 1891, 473; Oettel, Ch. Z., 1894, 879; Schweder, Berg-Hütt. Z., 36 5, 11, 21; Fernberger and Smith, J. Am. Ch. S., 21, 1001; Wagner, Z. f. Elektrochem., 2, 613; Oettel, Ch. Z. (1894), 47, 879; Foerster and Seidel, Z. f. anorg. Ch., 14, 106; Head, Trans. Am. Inst. Mining Engineers, 1898; Revay, Z. f. Elektrochem., 4, 313-329; Ullmann, Ch. Z., 22, 808; Hollard, C. r., 123, 1003 (1896); Kollock, J. Am. Ch. S., 21, 923; Richards and Bisbee, J. Am. Ch. S., 26, 530; Gooch, Am. Jr. Sc. [4th Series], xv, 320; Ch. News, 87, 284; Foerster and Coffetti, Z. f. Elektrochem., 10, 736; Denso, Z. f. Elektrochem., 9, 463; Medway, Am. Jr. Sc. [4th Series], xviii, 180; Heath, J. Am. Ch. S., 26, 1120-1125; Spitzer, Z. f. Elektrochem., 11, 391; Koch, Z. f. a. Ch., 41, 105; Danvé, J. pharm. Chim., [6], 16, 371; Kufferath, Z. f. ang. Ch., 17, 1785; Internationaler Congress für angew. Ch. [Berlin], Band 4, 677; Guess, Eng. Min. Jr., 81, 328 (1906); Exner, J. Am. Ch. S., 25, 897; Fischer and Boddart, Z. f. Elektrochem., 10, 947; Foerster, Z. f. ang. Ch., 19, 1890 (1906); Smith, J. Am. Ch. S., 26, 1614; Kollock and Smith, Am. Phil. Soc. Pr., 44, 143; Flanigen, J. Am. Ch. S., 29, 455; Langness, *ibid.*, 29, 460; Kollock and Smith, Am. Phil. Soc. Pr., 45, 257; Menozzi, Atti del VI Congresso Internazionale di Chimica Applicata, Septimo

Volume, p. 70, 1906; Free, Jr. Phys. Ch., 12, 28; Smalley, Trans. Faraday Soc., 6, 208; Withrow, Jr. Am. Ch. Soc., 30, 381; Blasdale and Cruess, Jr. Am. Ch. Soc., 32, 1264; Benner, Jr. Ind. and Eng. Ch., 2, 195; Heath, Jr. Ind. and Eng. Ch., 3, 74; Cavers and Chadwick, Eng. Min. J., 89, 954.

Dissolve 19.6 grams of pure copper sulphate in water, and dilute to 1 liter. Place 50 c.c. of this solution (=0.25 gram of metallic copper) in a *clean* platinum dish, previously

FIG. 24.

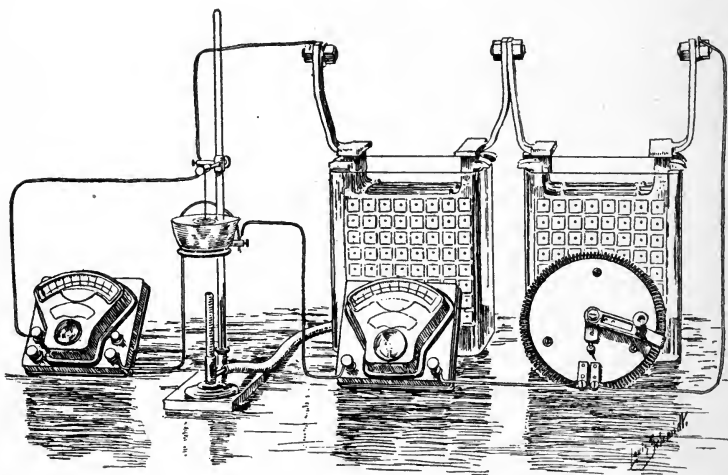

weighed. Arrange the apparatus as in the accompanying sketch (Fig. 24), the voltmeter being to the left of the dish and the milliamperemeter and the rheostat to the right-hand side of the same, and having done this, add 9-10 drops of concentrated nitric acid to the solution of the electrolyte, dilute to 125 c.c. with water, heat to 70° , and electrolyze with a current of $N.D._{100} = 0.09$ ampere and 1.9 volts. Cover the vessel with a perforated watch-crystal during the decomposition. Four to five hours will suffice for the precipitation. To ascertain when the metal has been completely precipitated,

add water to the dish; this will expose a clean platinum surface, and if in the course of half an hour no copper appears upon it, the deposition may be considered as finished. Or, a drop of the liquid may be removed and brought in contact with a drop of ammonium hydroxide or hydrogen sulphide, when, if a blue coloration or black precipitate is not produced, the deposition can be considered ended.

As the precipitation has been made in an acid solution the current should not be interrupted until the acid liquid has been removed, for in many cases the brief period during which the acid can act upon the metal will be sufficient to cause some of the latter to pass into solution. To obviate this, siphon off the acid liquid. As the acidulated water is conveyed away by the siphon, pour distilled water into the dish. Empty the platinum dish twice in this way; the current can then be interrupted without loss of copper. Finally, disconnect the dish, wash the deposit with hot water and then with alcohol and ether. Dry the precipitated copper at a temperature not exceeding 100° C.; an air-bath, an asbestos plate, or warm iron plate will answer for this purpose. Do not weigh the dish until it is perfectly cold, and has attained the temperature of the balance-room.

In heating the dish containing the electrolyte, do not apply a direct lamp flame; attach a circular piece of thin sheet-asbestos to the lower side of the ring, supporting the platinum dish, and under it place an ordinary Bunsen burner, or one reduced in size. Water-baths are not needed for heating purposes. See Withrow (Jr. Am. Ch. Soc., 30, 381) upon the influence of temperature in the precipitation of copper from solutions containing nitric acid.

Rüdorff suggests the addition of ten drops of a saturated sodium acetate solution to the acid liquid from which the copper has been precipitated before interrupting the current. The acetic acid, which is liberated, will not immediately at-

tack the copper, which can be at once washed and treated as just described.

Copper is very readily precipitated from solutions containing free nitric or sulphuric acid. Hydrochloric acid should never be used.

A platinum dish, 50 mm. in diameter and 20 mm. in depth, may be substituted for the spiral anode. There are openings in the dish to facilitate circulation and accelerate the precipitation of the metal.

The deposition of the copper can also be made in a platinum crucible, or upon the exterior surface of the same. This is sometimes convenient. Place the liquid undergoing electrolysis in a beaker (capacity 100-250 c.c.), and suspend the crucible in it, supporting it there by a tight-fitting cork, through which passes a stout copper wire, in connection with the negative electrode of a battery. The positive electrode is a platinum plate projecting into the liquid. The end of the decomposition may be learned by adding water to the solution in the beaker. No further appearance of copper on the newly exposed platinum indicates the end of the precipitation. Raise the crucible from the liquid, wash the copper with water, then detach the vessel carefully from the cork and dry as already directed.

If the current be permitted to act too long in the presence of sulphuric acid, copper sulphide may be produced. Black spots on the surface of the copper deposit indicate this.

Instead of using either of the suggestions first offered, substitute the apparatus of Richè if convenient. This consists in suspending a crucible within a crucible. The sides of the inner vessel are perforated so that the liquid will maintain uniform concentration.

Engels recommends the addition of urea or hydroxylamine sulphate to the copper sulphate solution, as it seems to favor the deposition of the metal. He, therefore, pro-

ceeds as follows: Add 10–15 c.c. of concentrated sulphuric acid and 1.5 grams of hydroxylamine sulphate, or 1 gram of urea, to the salt solution, dilute to 150 c.c. with water, heat to 70° , and electrolyze with a current of $N.D._{100} = 0.8-1.0$ ampere and 2.7–3.1 volts. The metal will be precipitated in one and one-half hours.

Copper can also be precipitated from the solution of ammonium-copper oxalate. To this end the copper solution (sulphate or chloride) is treated with an excess of a saturated solution of ammonium oxalate diluted to 120 c.c. with water; heated to 60° and electrolyzed with $N.D._{100} = 0.35-1.0$ ampere and 2.5 to 3.2 volts. As the metal begins to separate, and the original deep blue color of the liquid disappears, add 20–30 c.c. of a cold saturated solution of oxalic acid. This should be added gradually from a burette. Avoid the precipitation of insoluble copper oxalate. When the decomposition is finished, decant the solution, and wash the deposit of copper repeatedly with water and then with alcohol. Dry as previously directed. The precipitation is generally complete after three hours. Use ferrocyanide of potassium to learn whether all the metal has been precipitated.

E. Wagner recommends the following procedure in the precipitation of copper from an oxalate solution: Pour the copper solution into the ammonium oxalate solution (4 grams of ammonium oxalate in 60 grams of water for 1 gram of copper sulphate); at the beginning electrolyze with a current of 0.05 ampere for one-half hour, then introduce 5 c.c. of a cold saturated solution of oxalic acid, and at the expiration of five minutes increase the current to 0.3 ampere. The temperature of the electrolyte should equal 60° . In the following eighty minutes, during four intervals, 5 c.c. of oxalic acid are added at each period and the maximum current of 0.4 ampere is applied. Two hours after the close of the circuit neither ammonia nor potassium ferrocyanide will show the copper

reaction with the solution. The liquid should be siphoned off without the interruption of the current. The deposit of copper should be washed and dried as previously indicated.

Copper may also be determined quite accurately in solutions of the phosphate in the presence of free phosphoric acid, or in a formate solution containing free formic acid.

The following example is given to show the applicability of an acid phosphate solution for this particular purpose. To a solution of copper sulphate (= 0.1239 gram of copper) were added 20 c.c. of a solution of disodium hydrogen phosphate (sp. gr. 1.0358) and 5 c.c. of phosphoric acid (sp. gr. 1.347). It was then diluted to 225 c.c. with water, heated to 65°, and electrolyzed with a current of $N.D._{100} = 0.035-0.068$ ampere and 2.2-2.6 volts. The precipitation was completed in six hours. The deposit of copper weighed 0.1238 gram. It was washed and dried as previously directed, p. 71.

Rüdorff obtained excellent results with the following conditions: 0.1-0.3 gram of metallic copper in 150 c.c. of water, to which were added 2-3 grams of potassium or ammonium nitrate and 20 c.c. of ammonium hydroxide (0.91 sp. gr.). Electrolyze at the ordinary temperature with a current of $N.D._{100} = 1$ ampere and 3.3-3.6 volts. It is claimed that by observing the preceding conditions copper will be fully precipitated in the presence of chlorides. An excess of acetic acid should be added to the solution before the current is interrupted.

Oettel remarks on the precipitation of copper from ammoniacal solutions that the metal can be quantitatively deposited from a slightly ammoniacal liquid, containing ammonium nitrate, with a current density of 0.07-0.27 ampere per square decimeter. When ammonium nitrate is absent and the quantity of ammonia is large, the metal deposits become spongy. He found the most satisfactory concentration to be 0.8 gram of copper for 100 c.c. of liquid when using

a wire-form anode with a cylinder or cone as cathode. Chlorine, zinc, arsenic, and small amounts of antimony were without deleterious effect. In the presence of lead, bismuth, mercury, cadmium, and nickel the results were high.

Moore dissolves the recently precipitated copper sulphide, obtained in the ordinary course of analysis, in potassium cyanide; and, after the addition of an excess of ammonium

FIG. 25.

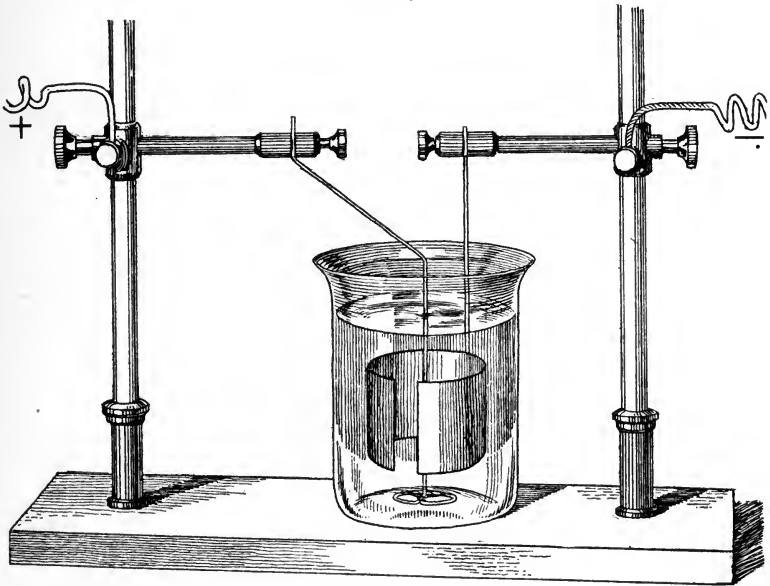

carbonate, electrolyzes the warm (70°) solution. In using this electrolyte, care should be taken to interrupt the current just as soon as the copper has been fully precipitated, otherwise metallic platinum may be deposited upon the copper.

In this laboratory it was observed that the electrolysis can be best and most satisfactorily executed by dissolving the sulphide in as small a volume of potassium cyanide as

possible, diluting to 150 c.c. with water, heating to 65° , and electrolyzing with $N.D._{100} = 0.15-0.8$ ampere and 3-4.5 volts. The metal will be fully precipitated in from two to three hours.

It has been asserted from time to time that in an alkaline cyanide solution there is great probability that the anode will suffer loss and that the dissolved platinum will reappear in the cathode. This point has been most carefully considered

FIG. 26.

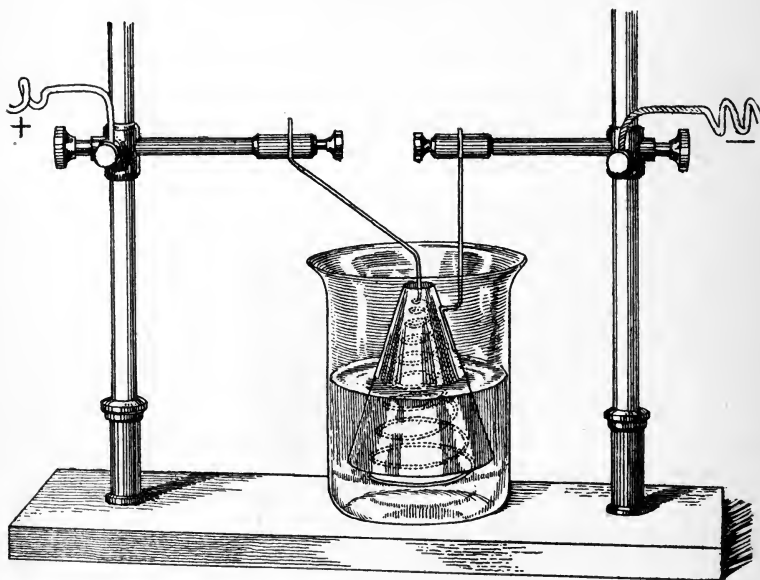

in this laboratory with the result that if the quantity of cyanide added to the copper solution be not more than enough to precipitate and redissolve the metallic cyanide there will be no solution of the platinum anode. Heating the solution to 65° favors the deposition of the copper. It was further ascertained that in the presence of a definite amount of ammonium hydroxide there is absolutely no loss sustained by the anode

in the cyanide electrolyte, and that the precipitation of metal is much accelerated. Two examples illustrate this:

COPPER IN GRAMS.	POTASSIUM CYANIDE IN GRAMS.	AMMONIUM HYDROXIDE IN C.C.	N. D. ¹⁰⁰ AMP.	VOLTS.	TEMPERATURE.	TIME IN HOURS.	GRAMS OF COPPER FOUND.
0.2015	1.5	10	1.00	5	65	1	0.2014
0.2015	1.5	10	0.66	5	65	1	0.2015

FIG. 27.

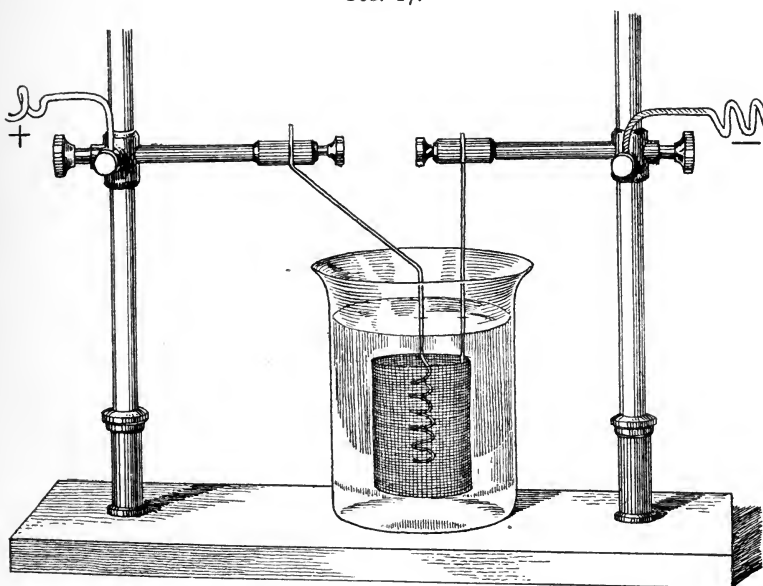

In the analysis of commercial copper Luckow employed the apparatus pictured in Fig. 25. The beaker contains the electrolyte and the metal is precipitated upon the cylinder of platinum. It is a very satisfactory device for almost any kind of electrolytic work. Either one of the arrangements pictured in Figs. 26 and 27 will answer for the same purpose. The platinum gauze cathode in Fig. 27 is much favored by

analysts. An anode of similar material and form can be used to advantage. To calculate the approximate surface of a cylindrical gauze cathode use the formula

$$S = 2\pi dlb\sqrt{n}$$

in which d is the diameter of the wire, n the number of meshes per square centimeter, l the length and b the width of the strip of gauze used (height of the cylinder). (Winkler, Ber., 32, 2192.)

The Rapid Precipitation of Copper With the Use of a Rotating Anode.

Arrange the apparatus and dish as pictured on p. 42. Use an anode of the form in Fig. 28. To the solution of the copper salt, placed in the dish, add one cubic centimeter of dilute sulphuric acid (1 : 10), dilute the solution to 125 c.c.,

FIG. 28.

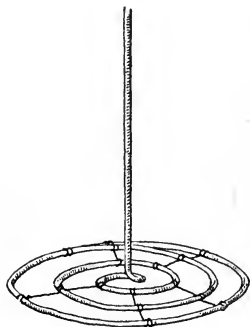
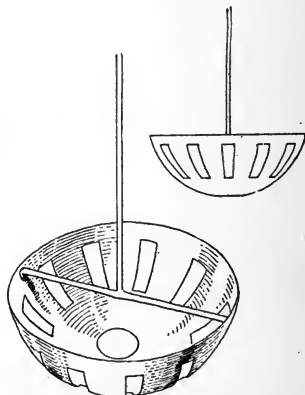

FIG. 29.



thus exposing a cathode area of 100 sq. cm., cover the dish with suitable glass covers, heat the liquid almost to boiling, remove the lamp, start the rotator, giving the anode a speed of 600 to 700 revolutions per minute, and let a current of five amperes and five volts pass. When the electrolysis is com-

plete (indicated by the colorless solution), stop the rotator, and reduce the current by throwing in resistance from the rheostat. Add distilled water to cover any exposed metal and thus prevent oxidation. Siphon off the acid liquor, keeping the dish, however, full by the addition of water from a wash bottle. Disconnect the dish, wash the deposit of copper with warm water, alcohol and ether. Dry and weigh. With the conditions just outlined, 0.4994 gram of metal was frequently deposited in five minutes. Miss Langness, working in this laboratory, precipitated 0.5035 gram of copper in seven minutes by the use of ten volts and 5 to 13 amperes. The deposits of metal were perfectly adherent, dark red in color, and had a beautiful velvet-like appearance.

Rate of precipitation:

In 1 minute.....	0.1493 gram of metal
In 2 minutes.....	0.3019 gram of metal
In 3 minutes.....	0.4371 gram of metal
In 4 minutes.....	0.4925 gram of metal
In 5 minutes.....	0.5029 gram of metal

Or, there may be used a dish anode with the form shown in Fig. 29 so constructed as to be about 7 cm. in diameter and 3 cm. deep, conforming throughout with the cathode (Langness, *J. Am. Ch. S.*, 29, 460). In its sides are ten slits perpendicular to the edge, each slit being 1.8 cm. long and 0.5 cm. wide. Free circulation of the electrolyte is insured by these openings and through a circular opening, 1.3 cm. in diameter, in the bottom of the dish. The anode is held in position by a stout platinum rod. The anode is so adjusted that it is equidistant from the sides of the cathode. The electrolyte, during the rotation of the anode, is all contained within the space bounded by the cathode and the outer surface of the anode. There is none within the inner dish. The dilution, therefore, is less than when using a spiral anode. When properly adjusted this anode occasions absolutely no splashing and no loss of electrolyte is sustained. To show the result, on

employing this anode, five actual experiments are here introduced:

No.	CU PRESENT IN GRAMS.	VOLTS.	AMPERES.	TIME, MIN.	WT. OF CU IN GRAMS.
1	0.4884	7+	10-15	4	0.4883
2	0.4884	8	10-15	3	0.4884
3	0.4884	8	10-15	5	0.4887
4	0.4884	8	10	2	0.4634
5	0.4884	8	10	1	0.2010

The electrolyte in each instance did not exceed sixty cubic centimeters in volume. The character of the metal deposits was the same as when using the spiral anode. The volume of free sulphuric (1 : 10) was 1 c.c. in all the trials just described.

It may be preferred to use a *nitric acid* electrolyte. If so, proper working conditions can be readily formed by observation of the following experiments:

No.	COPPER PRESENT IN GRAMS.	ACID IN C.C. SP. GR. 1 2.	DILUTION IN C.C.	VOLTS.	AMPERES.	TIME IN MINUTES.	COPPER IN GRAMS FOUND.
1	0.4876	0.5	125	8	7	15	0.4878
2	0.4876	0.5	125	8	7	15	0.4877
3	0.4876	0.5	125	8	8	15	0.4875
4	0.4876	0.5	125	8	8	10	0.4875

The spiral anode was used in these trials. The metal deposits were brilliant, adherent and crystalline.

Rate of precipitation:

In 1 minute.....	0.1507 gram of metal
In 2 minutes.....	0.2518 gram of metal
In 3 minutes.....	0.3418 gram of metal
In 4 minutes.....	0.3960 gram of metal
In 5 minutes.....	0.4486 gram of metal
In 6 minutes.....	0.4654 gram of metal
In 8 minutes.....	0.4852 gram of metal
In 10 minutes.....	0.4875 gram of metal

See also J. Am. Chem. S., 25, 898.

In an *ammoniacal* electrolyte, containing 0.4967 gram of copper, 1.2 gram of ammonium nitrate, total dilution 125 c.c., a current of 9 amperes and 8 volts, using the rotating spiral anode, precipitated 0.4963 grams of metal in fifteen minutes. The deposits were perfectly adherent and very bright in color. In this same electrolyte, if the *dish* anode be substituted and a current of seventeen amperes and six volts be employed, 0.4824 gram of copper can be easily precipitated in six minutes. (See also J. Am. Chem. S., 25, 898.)

The preceding conditions answer well for the determination of copper in chalcopyrite. The latter having been reduced to a fine powder is rapidly decomposed in a small beaker by boiling with concentrated nitric acid. When the decomposition is complete the solution is quickly evaporated to dryness, the residue moistened by a few drops of pure nitric acid, water added, the solution heated and then filtered into a weighed platinum dish where it is mixed with an excess of ammonium hydroxide. The iron will, of course, be precipitated as hydroxide but without paying attention to it the anode is put in motion and the solution electrolyzed. There is no danger of any of the ferric hydroxide attaching to the deposit of copper. The thorough agitation of the electrolyte prevents this. Numerous determinations have been made in this laboratory and the results have been most concordant. Of course if the plan is not approved by the analyst, ammonium hydroxide may be added directly to the acidulated (HNO_3) water solution of the mineral before filtering out the gangue, thus bringing the latter and the resulting ferric hydroxide together upon the filter. The blue colored ammoniacal filtrate will contain an abundance of ammonium nitrate so that one may proceed at once with its electrolysis as just directed.

An advantage possessed by this electrolyte is that in the ordinary course of analysis, copper is very frequently got in

the form of nitrate. See separation of copper from nickel (p. 197).

From an *alkaline cyanide* electrolyte the precipitation of copper proceeds rapidly and well. Thus, to a solution containing 0.2484 gram of metal there was added just enough potassium cyanide to precipitate copper cyanide and then dissolve it. On dilution, the liquid, being brought to boiling, was electrolyzed with a current of $N.D._{100} = 6$ amperes and 18 volts. The precipitation was complete in eighteen minutes. The deposit was deep red in color and shone as if it had been polished. The deposition of metal from this electrolyte is even more rapid, when using the dish anode (p. 78). Thus, to a solution of potassium copper cyanide (=0.4882 gram of copper) were added 10 c.c. of ammonium hydroxide (sp. gr. 0.93 at 24°) and it was electrolyzed with a current of 15 amperes and seven volts. In a period of six minutes 0.4883 gram of copper was precipitated.

Here, again is an admirable means of determining the copper content of minerals. Boil down to dryness a weighed amount (0.5 gram), for example, of finely divided chalcopryrite with aqua regia. Take up the residue with a little hydrochloric acid and water; filter and supersaturate the filtrate with hydrogen sulphide gas; filter out the copper sulphide and having washed it with hydrogen sulphide water, dissolve it from off the filter in as little warm dilute potassium cyanide as possible, collect the cyanide filtrate in a weighed platinum dish and electrolyze as directed in the preceding paragraph. The results will be perfectly satisfactory.

The Rapid Precipitation of Copper With the Use of the Rotating Anode and Mercury Cathode (J. Am. Ch. S., 25, 883; J. Am. Ch. S., 26, 1595; *ibid.*, 26, 1614; Am. Phil. Soc. Pr., xlv (1905), 137; J. Am. Ch. S., 27, 1527; Myers, J. Am. Ch. S., 26, 1124; Benner, J. Am. Ch. S., 32, 1231).

In the introduction (p. 63) reference was made to the form

of cell or cup which may be used with advantage when mercury is applied as a cathode in electro-analysis. Such cups can easily be made from ten-inch test tubes of soft glass. Into a tube of this kind introduce a layer of mercury sufficient to cover the platinum wire fused through the bottom or side of the cup. Weigh the cup, place it upon a plate of sheet copper, connected with the negative electrode of a battery, whereby the mercury becomes the cathode. Introduce a solution of copper sulphate, add a drop or two of sulphuric acid and suspend the anode from the rotator (see p. 63). Provide the cup with cover-glasses, notched so as to allow the passage of the anode. These glasses can be readily made from the slides used in microscopic work.

The anode is now rotated precisely as when making precipitations upon a platinum dish cathode (p. 78). When high currents are used the solution of the metal will frequently be heated to boiling. Some of the liquid will, of course, be carried to the sides of the cup and to the cover-glasses by the escaping gases or by the agitation of the liquid. Experience has shown that it is not necessary to wash down this portion, because the condensed steam continually frees the sides from the solution. The cover-glasses should now and then be tilted against the sides of the tube in order to run off the water which collects in large drops.

It has been repeatedly observed that the greater the concentration of the electrolyte, the greater the rapidity of deposition, but the last traces of metal separate slowly, so after a solution has become colorless, continue the electrolytic action several minutes in order to precipitate the minute amount remaining unprecipitated.

When the metal has been completely deposited, stop the rotator, remove the cover-glasses and fill the decomposition cell with distilled water. This should then be siphoned off to the level of the spiral and the liquid replaced by distilled

water until the current drops to zero. This wash water should always be put aside and tested to ascertain that the metal has been completely removed. Next interrupt the current, remove the tube and wash its contents again with distilled water, inclining and twirling the cell in order to more completely wash the amalgam. As much of the water as possible should be poured from the cell and the amalgam then be washed twice with absolute alcohol and twice with ether. It should be wiped dry on the outside and after the volatilization of the ether be placed in the desiccator and weighed as previously described.

The following experiments are taken from a laboratory notebook. They show that by the method just described, rapidity and accuracy are obtained without any difficulty whatsoever. Even inexperienced chemists get very satisfactory estimations not only of copper, but of other metals, as will be observed later.

No.	COPPER PRESENT IN GRAMS.	SULPHURIC ACID PRESENT IN C.C.	VOLUME IN C.C.	CURRENT AMPERES.	VOLTS.	REVOLUTIONS OF ANODE PER MINUTE	TIME IN MINUTES.	COPPER FOUND IN GRAMS.	ERROR IN GRAMS.
1	0.7890	.25	12	3.5	6	1200	10	0.7900	+0.0010
2	0.3945	.15	12	4	6	1080	5	0.3941	-0.0004
3	0.3945	.25	12	3.5	6	1200	6	0.3942	-0.0003
4	0.3945	.15	12	5	6.5	1200	5	0.3944	-0.0001
5	0.3945	.00	10	2.4	9.7	1200	6	0.3946	+0.0001
6	0.3945	.17	10	3.5	8.5	1200	4	0.3944	-0.0001
7	0.3945	.17	10	4	6	1080	5	0.3946	+0.0001

Rate of Precipitation.—In a solution of copper sulphate (5 c.c. in volume and containing 0.3945 gram of metallic copper) slightly acidulated with sulphuric acid, a current of 5 amperes and 6 volts precipitated the metal as follows:

In 1 minute.....	0.1800 gram
In 2 minutes.....	0.3400 gram
In 3 minutes.....	0.3664 gram
In 4 minutes.....	0.3945 gram
In 5 minutes.....	0.3945 gram

Remarks.—The following experiment was made to determine what loss, if any, was suffered by the mercury while standing in the desiccator. A cell filled and prepared as above was weighed. It was then returned to the desiccator and reweighed at intervals of twenty-four hours. A loss of 0.0001 gram per day was observed during the first week. The rate of loss then decreased to such an extent that the total loss after a period of twenty-six days amounted to only 0.0015 gram. It was frequently found upon reweighing a cell in the morning that no loss had occurred, the cell having remained in the desiccator over night.

It is necessary to keep the inside of the cell absolutely clean, otherwise the amalgam shows a tendency to cling to the glass. Losses may occur from this source, as exceedingly small globules of mercury are often detached by the wash water, as well as by the alcohol and ether. The escaping gases in an electrolysis whose high currents are employed will suffice to agitate the electrolyte for certain metals, but there are many more instances where mechanical agitation is required. (Stoddard *J. Am. Ch. S.*, 31, 385 (1909); Frary and Peterson, *Trans. Am. Electroch. Soc.*, 17, 295; Benner, *J. Ind. Eng. Chem.*, 2, 348; *J. Am. Ch. S.*, 32, 1231.)

An interesting experiment, that students should perform, consists in dissolving a weighed amount of pure copper sulphate in a small volume of water (5 to 10 cubic centimeters) and electrolyzing the solution in the manner just outlined with a mercury cathode and a rotating anode. Do not add any sulphuric acid. When the solution is colorless carefully siphon out the acid liquid into a beaker. Wash the amalgam as before, combining the wash water and the liquid first removed, after which titrate this solution with a $\frac{1}{10}$ normal sodium carbonate solution. The sulphuric acid content of the salt is thus obtained with great accuracy. The increase in weight of the mercury cup naturally gives the copper so that

a complete analysis of the salt (water of crystallization excepted), may be executed in a very few minutes.

A metallic nitrate may be analyzed as under *Nitric Acid*. (See page 289.)

For the estimation of the halogen content of metallic halides see pp. 93, 285, 292.

CADMIUM.

LITERATURE.—Ber., **11**, 2048; Smith, Am. Phil. Soc. Pr., 1878; Clarke, Z. f. a. Ch., **18**, 104; Beilstein and Jawein, Ber., **12**, 759; Smith, Am. Ch. Jr., **2**, 42; Luckow, Z. f. a. Ch., **19**, 16; Wrightson, Z. f. a. Ch., **15**, 303; Classen and v. Reiss, Ber., **14**, 1628; Warwick, Z. f. anorg. Ch., **1**, 258; Moore, Ch. News, **53**, 209; Smith, Am. Ch. Jr., **12**, 329; Vortmann, Ber., **24**, 2749; Rüdorff, Z. f. ang. Ch., Jahrg. 1892; Classen, Ber., **27**, 2060; Heidenreich, Ber., **29**, 1586; Wallace and Smith, J. Am. Ch. S., **19**, 870; *ibid.*, **20**, 279; Balachowsky, C. r., **131**, 384; Miller and Page, Z. f. anorg. Ch., **28**, 233; Kollock, J. Am. Ch. S., **21**, 911; Avery and Dales, J. Am. Ch. S., **19**, 380; Medway, Am. Jr. Science [4th Series], **18**, 56; Flora, Am. Jr. Science [4th Series], **20**, 268; Z. f. anorg. Ch., **47**, 13; Danneel and Nissenson, Internationaler Congress für angew. Ch. (1903), Bd. **4**, 680; Exner, J. Am. Ch. S., **25**, 902; Davison, J. Am. Ch. S., **27**, 1275; Kollock and Smith, J. Am. Ch. S., **27**, 1528; Fischer and Boddart, Z. f. Elektrochem., **10**, 948; Foerster, Z. f. ang. Ch., **19**, 1890; Kollock and Smith, Am. Phil. Soc. Pr., **45**, 260; Benner and Ross, J. Am. Ch. S., **33**, 1106.

Cadmium can be determined electrolytically as readily as copper. Prepare a solution of the chloride or sulphate of definite strength. Remove 50 c.c. to a suitable, weighed platinum vessel. Add one gram of pure potassium cyanide; dilute with water to 125 c.c., heat to 60°, and electrolyze with N.D.₁₀₀ = 0.06 ampere and 3.2 volts. The metal will be completely deposited in five hours, or the decomposition may be begun in the evening and by morning the metal will be fully precipitated. To ascertain whether the precipitation is complete, raise the level of the liquid in the platinum dish. Wash the deposit with cold and hot water; also with alcohol

and ether. Dry upon a warm iron plate (temperature not exceeding 100° C.).

This metal can be deposited from the solution of its phosphate in phosphoric acid. The conditions that follow, gave very satisfactory results; a current of $N.D._{100} = 0.06$ ampere and 3-7 volts acted upon 0.1656 gram of cadmium as sulphate, 30 c.c. of sodium phosphate (1.0358 sp. gr.), and 1.5 c.c. of phosphoric acid (sp. gr. 1.347). The total dilution equaled 100 c.c. The temperature of the solution was 50° . The precipitated cadmium weighed (a) 0.1654 gram and (b) 0.1657 gram. The current for the last hour of the decomposition should be increased and the deposit be washed before breaking the current.

Cadmium may also be precipitated from a solution of its sulphate containing a small amount of free sulphuric acid (2 c.c. H_2SO_4 , sp. gr. 1.09, for 0.1 gram of cadmium). Heat to 50° and electrolyze with $N.D._{100} = 0.15$ ampere and 2.5 volts. Siphon off the acid liquid before interrupting the current. Treat the deposit as previously directed.

Cadmium can also be deposited quite readily, and in a crystalline form, from its acetate solution. An example will indicate the proper conditions for a successful determination: 0.1329 gram of cadmium oxide was dissolved in acetic acid, the solution was evaporated to dryness, and the residue dissolved in 30 c.c. of water. The liquid was then heated to 50° and electrolyzed with a current of 0.02 ampere for 37 sq. cm. of cathode surface and a pressure of 3.5 volts. The metal was completely precipitated in four hours. It was crystalline and adherent. The acid liquid should be siphoned off without interrupting the current. Good results can be obtained and the period of precipitation be reduced by adding 1 gram of ammonium acetate to the solution after the current has acted for an hour. When the precipitation is completed, detach the dish, wash the deposited metal first with warm water,

then with absolute alcohol, and finally with ether. Dry upon a moderately warm plate.

Balachowsky, in precipitating cadmium, makes use of a silver-coated platinum dish. Dissolve from 1.5 to 2 grams of cadmium sulphate in 100 c.c. of water, add 5 c.c. of acetic acid for every gram of salt, heat to 60° and electrolyze with a current of 0.004 ampere per sq. cm. and 2.8 volts. Later increase the current to 0.006 ampere and 3.5 volts. The deposited metal should be treated as already described.

The same chemist also obtained very satisfactory results by adding formaldehyde, acetaldehyde, or urea to the solution of cadmium sulphate. The liquid was then heated to 60° and electrolyzed with a current of 2.5–3.3 volts and 0.003 to 0.006 ampere per sq. cm.

If desired, the metal can also be precipitated from the solution of the double oxalate of ammonium and cadmium (*see* Copper), or from a formate solution in the presence of free formic acid.

When using the oxalate solution, add to it for every 0.3 to 0.4 gram of sulphate, 10 grams of ammonium oxalate, dilute to 120 c.c. with water, heat to 75° , and electrolyze with $N.D._{100} = 0.5\text{--}1.5$ ampères, and 3–3.5 volts. The time necessary for complete precipitation will be three and one-half hours.

Avery and Dales employed the formate solution. Their recommendation is: Add 6 c.c. of formic acid (sp. gr. 1.20) to the solution of cadmium sulphate, then potassium carbonate until a slight permanent precipitate is formed, which is just dissolved in formic acid, after which 1 c.c. of the same acid is introduced, the liquid diluted to 150 c.c. and electrolyzed with $N.D._{100} = 0.15\text{--}0.20$ ampere and 2.6–3.4 volts.

Vortmann has determined several metals quite satisfactorily in the form of amalgams. In applying his recommendation to cadmium, add to the solution of its salt a solution of mercuric chloride and 5 grams of ammonium oxalate. Effect the

solution of the latter salt without the aid of heat. This procedure is only good when small amounts of cadmium are present; cadmium ammonium oxalate is not very soluble. The current employed for the precipitation should at the very beginning of the decomposition equal from 0.6 to 0.8 ampere. When the amalgam of mercury and cadmium commences to separate, reduce the current to 0.3 ampere, but gradually increase it until at the end of the decomposition it has its initial strength. If the quantity of cadmium exceeds 0.3 gram, let the solution undergoing electrolysis be ammoniacal. To this end add tartaric acid (3 grams) and an excess of ammonia to the liquid containing the mercury and the cadmium. Dilute to 200 c.c. with water. Allow the current to act until a portion of the liquid remains clear when tested with ammonium sulphide.

In the usual course of gravimetric analysis cadmium is obtained as sulphide. To prepare it for electrolysis, dissolve the same in nitric acid, and after expelling the excess of the latter, add a small amount of potassium hydroxide (sufficient to precipitate the cadmium), and follow this with an excess of potassium cyanide (1 to 2 grams). Proceed further as already directed.

The Rapid Precipitation of Cadmium With the Use of a Rotating Anode.

Arrange apparatus as outlined under COPPER. To the solution of cadmium sulphate (=0.2756 gram of cadmium), add 3 c.c. of sulphuric acid (1 : 10), dilute to 125 c.c. with water, heat to incipient boiling, remove the lamp, rotate the anode at the rate of 600 revolutions per minute, and electrolyze with a current of $N.D._{100} = 5$ amperes and 8 to 9 volts. In ten minutes the precipitation of cadmium will be complete. In one actual experiment 0.2756 gram was found, and in another where 0.5512 gram metal was present 0.5508 gram was pre-

precipitated in fifteen minutes. The deposits are grey in color, crystalline, and adherent. Much sulphuric acid retards the complete deposition of metal. It was also found in the presence of 0.5 c.c. sulphuric acid (1 : 10) by using a current of $N.D._{100} = 4$ amperes and 14 volts that as much as 0.5762 gram of metal could be precipitated in eight minutes.

Rate of precipitation:

In 1 minute.....	0.1190 gram
In 2 minutes.....	0.2245 gram
In 3 minutes.....	0.3417 gram
In 5 minutes.....	0.5217 gram
In $7\frac{1}{2}$ minutes.....	0.5760 gram
In 8 minutes.....	0.5762 gram

The deposition of cadmium from an *ammoniacal electrolyte* with stationary electrodes never gave satisfaction. By using a rotating anode, however, this electrolyte may be employed. To the solution of the cadmium salt add ammonium hydroxide sufficient to precipitate the metallic hydroxide and to redissolve it. To this solution add a solution of 10 c.c. sulphuric acid (1 : 10) neutralized with ammonia, dilute to 125 c.c., and electrolyze with $N.D._{100} = 5$ amperes and 6.5 volts. In ten minutes the deposition will be complete. In this electrolyte the *rate of precipitation* was as follows:

In 1 minute.....	0.1312 gram
In 2 minutes.....	0.2708 gram
In 3 minutes.....	0.2868 gram
In 4 minutes.....	0.2889 gram
In 5 minutes.....	0.2887 gram

As observed in a preceding paragraph a *formate electrolyte* answers well for the precipitation of cadmium. Upon introducing the rotating anode in connection with it, the cadmium is deposited in a very few minutes. This is evidenced by one from a number of examples:

To a solution, containing 0.2898 gram of cadmium as sul-

phate add five grams of sodium carbonate and 16 c.c. of formic acid (sp. gr. 1.06), after which dilute to 125 c.c., heat the electrolyte to boiling, remove the flame, rotate the anode at 600 revolutions per minute, and apply a current of $N.D._{100} = 5$ amperes and 5 volts. In fifteen minutes 0.2900 gram of metal was precipitated.

Again—to a solution containing 0.2898 gram of cadmium add 1.25 gram of sodium carbonate, 5 c.c. of formic acid (sp. gr. 1.06) and electrolyze with $N.D._{100} = 5$ amperes and 9 volts, when the entire quantity of metal will be precipitated in five minutes. Thus from this electrolyte there was deposited:

In 1 minute.....	0.1645 gram of cadmium
In 2 minutes.....	0.2816 gram of cadmium
In 3 minutes.....	0.2891 gram of cadmium
In 4 minutes.....	0.2896 gram of cadmium

In an electrolyte containing *ammonium formate* in the presence of either ammonium hydroxide or formic acid the deposition of cadmium takes place equally well. Thus, with 0.2898 gram of metal in the presence of 5 c.c. of ammonium hydroxide, and 10 c.c. of formic acid (sp. gr. 1.06) a current of $N.D._{100} = 5$ amperes and 6 volts, the anode making 690 revolutions per minute, there was precipitated:

In 1 minute.....	0.1612 gram
In 2 minutes.....	0.2850 gram
In 3 minutes.....	0.2904 gram

The deposits of metal resembled those from the sodium formate electrolyte.

One of the very first electrolytes suggested for the precipitation of cadmium was *sodium acetate* in the presence of free acetic acid. The results from it have been most satisfactory. By employing the rotating anode the time factor may be reduced to a few minutes. Starting with a cadmium sulphate

solution containing 0.3984 gram of metal add to it 3 grams of sodium acetate and 0.25 c.c. of dilute acetic acid, dilute to 125 c.c., and electrolyze with a current of $N.D._{100} = 5$ amperes and 8.5 to 9 volts. The anode should perform 600 revolutions per minute. With these conditions the *rate of precipitation* will be:

In 1 minute.....	0.1601 gram of cadmium
In 2 minutes.....	0.2863 gram of cadmium
In 3 minutes.....	0.3963 gram of cadmium
In 4 minutes.....	0.3987 gram of cadmium

Ammonium acetate may be substituted for the sodium salt. In such cases it is advisable to have acetic acid present from the very beginning.

With an *alkaline cyanide* electrolyte follow the conditions of an actual experiment: Add to a solution of cadmium sulphate (=0.4568 gram of metal), 3 grams of pure potassium cyanide, 1 gram of sodium hydroxide, dilute to 125 c.c. with water, and electrolyze with $N.D._{100} = 5$ amperes and 5.5 volts. The *rate of precipitation* will then be:

In 1 minute.....	0.1808 gram of metal
In 2 minutes.....	0.2585 gram of metal
In 3 minutes.....	0.3291 gram of metal
In 5 minutes.....	0.3778 gram of metal
In 7½ minutes.....	0.4348 gram of metal
In 10 minutes.....	0.4534 gram of metal
In 15 minutes.....	0.4568 gram of metal

The cadmium deposits were here lustrous and of a silver-white color.

Ammonium and sodium acetates are not very good electrolytes for this metal, while ammonium succinate in the presence of a slight excess of succinic acid yielded good results, the deposits being similar to those from a formate or an acetate electrolyte. With sodium succinate free acid is not favorable to the character of the deposit. As much as 0.4 gram of metal can be deposited in a period of ten minutes.

The Rapid Precipitation of Cadmium With the Use of the Rotating Anode and Mercury Cathode.

Use the apparatus described under COPPER (p. 63). Weigh the cup with its layer of mercury, introduce an aqueous solution of cadmium sulphate (= 0.9480 gram of metal), and apply a current of 1.5 to 3.5 amperes and 10 to 7 volts. At the expiration of fifteen minutes the precipitation of the cadmium will be finished. Wash and dry as directed under COPPER. The anode should make 360 revolutions per minute. The amalgam will be quite bright in appearance. *The rate of precipitation* of the cadmium is as follows:

In 1 minute.....	0.1531 gram
In 2 minutes.....	0.4984 gram
In 7 minutes.....	0.8707 gram
In 9 minutes.....	0.9480 gram
In 10 minutes.....	0.9484 gram

One cubic centimeter (40 drops) of concentrated sulphuric acid will retard the deposition of this metal quite markedly. Half of this volume of acid will do no harm.

Under the preceding metal, COPPER, mention was made of the mercury cathode and the rotating anode in the analysis of metallic sulphates and nitrates. How the halogens may be simultaneously determined will be outlined later (p. 292). At this point, however, it seems advisable to indicate the course of procedure in the analysis of a metallic halide when the determination of the halogen element is of secondary importance while that of the metal is of chief importance. If the apparatus, just employed with the sulphate, be used with halides, under the influence of high current densities, there will be a copious evolution of halogens and these will attack the rotating anode most energetically. To offset these unfavorable conditions place a layer of toluene or xylene upon the solution of the metal halide. Either liquid will completely absorb the liberated halogen. Chlorides of cobalt, gold, iron, mercury,

and tin were quickly analyzed in this way with the utmost ease and satisfaction. In the case of cadmium the bromide was used. Its solution was so prepared that 5 c.c. of it contained 0.2212 gram of metal. After the addition of 10 c.c. of toluene the liquid was electrolyzed with a current of 2 amperes and 5 volts. The toluene became red in color but later changed to yellow. The odor of bromine was not detected. In ten minutes 0.2215 gram of metal was precipitated.

See J. Am. Ch. S., 27, 1547, Journal of the Chemical Society (London), 87, 1034; and Benner, J. Am. Ch. S., 32, 1234.

MERCURY.

LITERATURE.—Ber., 6, 270; Clarke, Am. Jr. Sc. and Ar., 16, 200; Classen and Ludwig, Ber., 19, 323; Hoskinson, Am. Ch. Jr., 8, 209; Smith and Knerr, *ibid.*, 8, 206; Smith and Frankel, Am. Ch. Jr., 11, 264; Smith, Jr. An. Ch., 5, 202; Vortmann, Ber., 24, 2749; Brandt, Z. f. a. Ch., 1891, p. 202; Rüdorff, Z. f. ang. Ch., 1892, p. 5; Eisenberg, Thesis, Heidelberg, 1895; Schmucker, J. Am. Ch. S., 15, 204; Frankel, Jr. Fr. Ins., 1891; Rising and Lenher, Berg-Hütt. Z., 55, 175; Wallace and Smith, J. Am. Ch. S., 18, 169; Fernberger and Smith, J. Am. Ch. S., 21, 1006; Kollock, J. Am. Ch. S., 21, 911; Bindschedler, Z. f. Elektrochem., 8, 329; Glaser, Z. f. Elektrochem., 9, 11; Matolcsy, Ch. Blatt., 77 Jahrg. (1906), 166; Exner, J. Am. Ch. S., 25, 901; Kollock and Smith, J. Am. Ch. S., 27, 1537; R. O. Smith, J. Am. Ch. S., 27, 1270; Fischer and Boddart, Z. f. Elektrochem., 10, 949; v. Borelli, Gazzetta Chimica Italiana, 37 (1907), 425; Perkin, Trans. Faraday, Soc., 5, 45.

In preparing solutions for experimental purposes, use either mercuric nitrate or chloride. To a definite portion of such a solution, add 3 c.c. of concentrated nitric acid, dilute to 125 c.c., heat to 70°, and electrolyze with a current of $N.D._{100} = 0.06$ ampere and 2 volts. The metal will be fully precipitated in four hours. The deposit will be drop-like in appearance. The acid liquid must be removed before the interruption of the current occurs, or sodium acetate should be added; then the

liquid can be decanted without the possibility of loss from re-solution of the mercury (Rüdorff).

A mercuric chloride solution, feebly acidulated with sulphuric acid (0.5 c.c. of sulphuric acid), diluted to 125 c.c., heated to 65°, and electrolyzed with a current of $N.D._{100} = 0.4-0.6$ ampere and 3.5 volts, will yield all its metal in one hour. Always wash the deposited metal with cold water. Rüdorff recommended the addition of the following substances to the liquid containing the mercury salt: 0.5 gram of tartaric acid and 10 c.c. of ammonium hydroxide (sp. gr. 0.91), or 5 c.c. of nitric acid, 10 c.c. of a saturated solution of sodium pyrophosphate, and 10 c.c. of ammonium hydroxide. A current of 0.02 ampere will precipitate the mercury in a compact adherent form.

From experiments made in this laboratory the writer prefers and would especially recommend solutions of the double cyanide of mercury and potassium for the electrolytic deposition of mercury. To the mercury salt solution, add 1 gram of pure potassium cyanide for every 0.1-0.2 gram of metal, dilute with water to 100 c.c., heat to 65°, and electrolyze with a current of $N.D._{100} = 0.02-0.07$ ampere and 1.6-3.2 volts. As much as 0.25 gram of metal can be deposited in three hours. This procedure requires no further attention after it is once set in operation. The deposit is always compact and gray in color. Use water only in washing it, for alcohol seems to detach some of the metallic film. In all precipitations of mercury, it is advisable to have this metal deposited upon a layer of metallic silver, hence invariably coat the platinum dishes with this metal.

Classen recommends the double oxalate solution for electrolytic purposes and to that end adds to the mercuric chloride solution from 4 to 5 grams of ammonium oxalate, dilutes with water to 120 c.c., and electrolyzes at 29-37° with a current of $N.D._{100} = 1$ ampere and 4.05-4.7 volts. The mercury comes

down in a perfectly adherent form, the time depending entirely upon the pressure.

The precipitation is also very satisfactory in a phosphoric acid solution, as is seen in the following example: To a solution, containing 0.1159 gram of mercury, were added 30 c.c. of sodium phosphate (sp. gr. 1.038) and 5 c.c. of phosphoric acid (sp. gr. 1.347), after which it was diluted to 175 c.c. with water heated to 50°, and electrolyzed for four hours with a current of $N.D._{100} = 0.04$ ampere and 1.6 volts. The deposit of mercury weighed 0.1162 gram. It was treated in the usual manner.

In general analysis mercury is frequently obtained as sulphide. Its determination in this form requires time and exceeding care. It is, however, soluble in the fixed alkaline sulphides containing free alkali. The writer has discovered that such a solution can be electrolyzed without difficulty; the mercury is deposited from it in a very compact form. An actual analysis conducted in this laboratory will best present the proper conditions for a successful determination: 20 c.c. of a sodium sulphide solution (sp. gr. 1.19) were added to a mercuric chloride solution (=0.1903 gram of mercury), and the whole then diluted to 125 c.c. with water. This was acted upon with a current of $N.D._{100} = 0.11$ ampere and 2.5 volts for five hours. The temperature of the solution was 70°. The weight of the precipitated mercury was 0.1902 gram. It was further treated as advised in the preceding paragraphs. It is best to use a platinum dish as the negative electrode and a platinum spiral (p. 78) for the anode. Dry the deposit on a moderately warm plate or over sulphuric acid.

Several determinations of mercury in cinnabar were made to test the general applicability of the method. Samples of the mineral, analyzed in the usual gravimetric way, showed the presence of 85.40 per cent. of metallic mercury. Portions of the same mineral were weighed out in platinum dishes and

after solution, in 20 to 25 c.c. of sodium sulphide of the specific gravity previously mentioned, were diluted with water to 125 c.c. and electrolyzed at 70° , with the conditions recorded in the preceding paragraph. The period of time allowed for the precipitations never exceeded three hours. The results were:—

CINNABAR IN GRAMS.	MERCURY IN GRAMS.	MERCURY PERCENTAGE.
0.2167	0.1850	85.37
0.2432	0.2077	85.40

The platinum dishes were covered during the electrolytic decomposition. It should be done in the determination of every metal. Its purpose here was to prevent evaporation, thereby exposing a rim of metal, which, if in part not volatilized, would yet be changed to mercury sulphide indicated by a dark-colored film.

The Rapid Precipitation of Mercury With the Use of a Rotating Anode.

In a *nitric acid* electrolyte, with 0.5840 gram of mercury as mercurous nitrate and one cubic centimeter of concentrated nitric acid, a current of $N.D._{100} = 7$ amperes and 12 volts precipitated the whole of the metal in seven minutes. The anode performed 700 revolutions per minute.

To show the *rate of precipitation* from this electrolyte a solution containing 0.5120 gram of metal was exposed to the action of the current with the following results:

Metal deposited in 2 minutes.....	0.3612 gram
Metal deposited in 4 minutes.....	0.4772 gram
Metal deposited in 8 minutes.....	0.5077 gram
Metal deposited in 10 minutes.....	0.5122 gram
Metal deposited in 12 minutes.....	0.5121 gram
Metal deposited in 20 minutes.....	0.5119 gram

In these speed trials the pressure never exceeded 7 volts. It was usually 6.5 volts. The total dilution of the electrolyte was 115 cubic centimeters.

Upon using an *alkaline sulphide electrolyte* it was found to answer admirably in the precipitation of mercury with the help of a rotating anode. Thus to a mercuric chloride solution, containing 0.2603 gram of metal, were added 10 c.c. of a sodium sulphide solution of sp. gr. 1.17, diluted to 115 c.c., and electrolyzed with a current of $N.D._{100} = 6$ amperes and 7 volts, the anode being rotated as indicated in the preceding paragraph. In fifteen minutes 0.2602 gram of metal was precipitated.

The *rate of precipitation* was found to be:

Metal deposited in 2 minutes.....	0.1371 gram
Metal deposited in 5 minutes.....	0.2198 gram
Metal deposited in 8 minutes.....	0.2538 gram
Metal deposited in 10 minutes.....	0.2554 gram
Metal deposited in 12 minutes.....	0.2596 gram
Metal deposited in 13 minutes.....	0.2601 gram
Metal deposited in 15 minutes.....	0.2602 gram
Metal deposited in 20 minutes.....	0.2604 gram

This scheme may be applied in determining the mercury in cinnabar as described in an earlier paragraph. For example, an ore that showed the presence of 46.20 per cent. mercury, when analyzed by the distillation method, gave 46.40, 46.46, 46.40, 46.41, 46.40, 46.46 per cent. by the procedure just outlined. The deposits of mercury were all that could be desired. The time necessary for each determination, from the weighing of the ore until the mercury deposit itself was weighed, did not exceed an hour and thirty minutes. The quantity of ore varied from 0.3 gram to 0.5 gram.

It is not too much to say that, in the light of many similar experiences had in this laboratory, the electrolytic method is vastly superior to the time-honored methods generally employed in the estimation of mercury.

The Rapid Precipitation of Mercury With the Use of the Rotating Anode and Mercury Cathode.

Use the same apparatus here as described under cadmium and copper. A mercurous nitrate solution contained 0.3570 gram of mercury in five cubic centimeters. Nitric acid, sufficient to prevent the formation of a basic salt, was also present. Using a current of 3 amperes and a pressure of 7 to 5 volts the *rate of precipitation* was:

In 1 minute.....	0.2777 gram of mercury
In 2 minutes.....	0.3542 gram of mercury
In 3 minutes.....	0.3572 gram of mercury

Dilution with water to 25 c.c. prolonged the period of complete precipitation to 8 minutes. The addition of too much free nitric acid also exerted a retarding influence.

Mercuric chloride may also be analyzed in this way, applying, however, the precautionary method of adding toluene (p. 93) so that the anode is not attacked by the liberated chlorine. Thus, to 5 c.c. of this salt, equivalent to 0.2525 gram of mercury, were added 10 c.c. of toluene and the decomposition made with a current of from 1 to 3 amperes and 10 to 7.5 volts. In ten minutes the metal was completely deposited.

Trials recently conducted in this laboratory prove that if cinnabar is decomposed with *aqua regia*, the solution evaporated to dryness, the residue taken up with water and filtered from gangue the liquid may be electrolyzed in the manner just described with good results.

BISMUTH.

LITERATURE.—L u c k o w, Z. f. a. Ch., 19, 16; C l a s s e n and v. R e i s s, Ber., 14, 1622; T h o m a s and S m i t h, Am. Ch. Jr., 5, 114; M o o r e, Ch. N. 53, 209; S m i t h and K n e r r, Am. Ch. Jr., 8, 206; S c h u c h t, Z. f. a. Ch., 22, 492; E l i a s b e r g, Ber., 19, 326; B r a n d, Z. f. a. Ch., 28, 596; V o r t m a n n, Ber., 24, 2749; R ü d o r f f, Z. f. ang. Ch., 1892, 199;

Smith and Saltar, *Z. f. anorg. Ch.*, **3**, 418; Smith and Moyer, *J. Am. Ch. S.*, **15**, 28; *ibid.*, **15**, 101; Wieland, *Ber.*, **17**, 1612; Smith and Knerr, *Am. Ch. Jr.*, **8**, 206; Schmucker, *Z. f. anorg. Ch.*, **5**, 199; *J. Am. Ch. S.*, **15**, 203; Kollock, *J. Am. Ch. S.*, **21**, 925; Wimmenauer, *Z. f. anorg. Ch.*, **27**, 1; Brunck, *Ber.* **35**, 1871; Balachowsky, *C. r.*, **131**, 179-182; Hollard and Bertiaux, *C. r.*, cxxxix (1904), 839; Exner, *J. Am. Ch. S.*, **25**, 901; Kollock and Smith, *J. Am. Ch. S.*, **27**, 1539; Fischer and Boddaert, *Z. f. Elektrochem.*, **10**, 947; Metzger and Beans, *Jr. Am. Ch. Soc.*, xxx, 589; Peset, *Z. f. analyt. Ch.*, **47**, 401.

The electrolytic determination of bismuth has received much attention. Numerous electrolytes have been suggested. Most of them have failed in that the deposits of metal, unless very small in amount, have almost invariably been dark in color and have shown a tendency to sponginess. Yet they were in nearly all cases adherent. There has been an additional objection in many of the methods to the separation of peroxide upon the anode. In short, the appearance of bismuth at both poles has been very disturbing. For these reasons many of the earlier suggestions have been abandoned, and will be omitted from the present text.

Vortmann prefers the amalgam method, in accordance with which dissolve 0.5 gram of bismuth trioxide and 2 grams of mercuric oxide in sufficient nitric acid for the purpose, dilute with water to 150 c.c., and at the ordinary temperature electrolyze with $N.D._{100} = 1$ ampere and 3.5 volts. The amalgam, when the ratio is 4Hg to 1Bi, will be silver-white in color. It should be washed without interrupting the current, then carefully dried and weighed. The method is said to be especially well adapted for the precipitation of large quantities of bismuth.

Wimmenauer has reviewed the different methods proposed from time to time, and from his experience recommends the following procedure: Dissolve 0.1-0.3 gram of bismuth nitrate in 2-4 c.c. of a glycerol solution (1 part of commercial glycerol and 2 parts of water), dilute with water to 150 c.c., and elec-

trolyze at 50° , in a roughened dish, with a current of $N.D._{100} = 0.1$ ampere and 2 volts. The anode is rotated during the decomposition. This can be accomplished by a small electric motor, as shown in Fig. 30. The rotation is supposed to prevent the formation of peroxide, because the latter, by the movement of the anode, is immediately brought in contact with dilute nitric acid, in which it dissolves. When the anode is at rest, a protective layer of gas forms about it, and this is favorable to the deposition of peroxide.

FIG. 30.

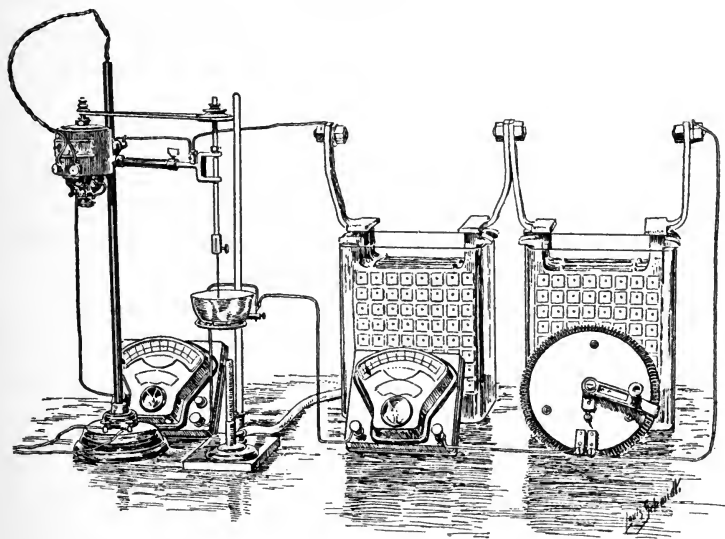

A. L. Kammerer, who has made an exhaustive study on the electrolytic determination of bismuth in this laboratory, where he has tried every form of cathode and anode with varying electrolytes, concludes that the following conditions may be relied upon to yield satisfactory results: 0.10–0.15 gram of metal in 1 c.c. of nitric acid (sp. gr. 1.42), 2 c.c. of sulphuric acid (sp. gr. 1.84), 1 gram of potassium sulphate, 150 c.c. total

dilution $N.D._{100} = 0.02$ ampere, $V = 1.8$. Temperature, 45° – 50° ; time, 6–7 hours.

The current should be increased the last hour to 0.15 ampere. Heat is absolutely essential in order to get a bright metallic deposit of metal. The deposit should be washed without interrupting the current, just as has been recommended with other metals when precipitated from an acid solution. Close-fitting cover-glasses should always be used to reduce the evaporation to a minimum. The metal seemed to be deposited as well upon smooth as upon roughened surfaces.

The many successful determinations made in accordance with the directions just described indicate that the method is perhaps the best which has ever been applied in the case of this particular metal.

In determining bismuth Balachowsky keeps in view the following points: (a) A slightly acid solution; (b) the absence of large amounts of the halogens; (c) the use of a low current density (not exceeding 0.06 ampere per square decimeter); (d) a roughened dish; (e) the addition of urea or aldehyde. He offers this example: 0.06–1.7 grams of bismuth sulphate, 5–7 c.c. of nitric acid, 150 c.c. of water, 3.5–5 grams of urea; $N.D._{100} = 0.04$ – 0.06 ampere and 1–2 volts. Temperature, 60° – 70° ; time, 6–10 hours.

When it is necessary to use an alkaline citrate or citric acid solution in the precipitation of bismuth, observe the following conditions: 0.1822 gram of bismuth, 3 grams of citric acid, 125 c.c. total dilution; $N.D._{100} = 0.03$ ampere, volts = 2. Temperature, 65° ; time, 6 hours. 0.1820 gram of bismuth was found. Weigh the anode before and after the electrolysis.

The Rapid Precipitation of Bismuth With the Use of a Rotating Anode.

As much as 0.5510 gram of the metal, in the presence of 1 c.c. of concentrated nitric acid, may be precipitated in

twenty minutes with a current of $N.D._{100} = 1$ ampere and 2.5 volts. The anode should rotate at the rate of 700 to 900 revolutions per minute. At first the deposit of metal will be white and crystalline, becoming loose and black later, but sufficiently adherent for washing and weighing purposes.

It is preferable, however, to precipitate the bismuth in the presence of mercury as an amalgam. Thus to a solution of bismuth nitrate, equivalent to 0.2970 gram of metal, add as much mercury in the form of mercurous nitrate and 1 c.c. of concentrated nitric acid. Heat the solution to boiling and electrolyze with a current of $N.D._{100} = 5$ amperes and 8.5 volts. Complete precipitation of the metals as an amalgam will occur in from eight to ten minutes.

The Rapid Precipitation of Bismuth With the Use of a Rotating Anode and a Mercury Cathode.

Frequent reference has been made in preceding paragraphs to the difficulty experienced in the precipitation of the metal bismuth and emphasis was laid repeatedly on the strict observance of the working conditions which proved satisfactory, so that naturally the analyst unconsciously turns from the electrolytic procedure when estimating this metal. However, with the simple device of a mercury cup and rotating anode as outlined and used with the preceding metals the determination can be made without trouble.

To a solution of 0.2273 gram of metal, not exceeding 12 c.c. in volume, add 0.5 c.c. of concentrated nitric acid and electrolyze with a current of 4 amperes and 5 volts. All the metal will be precipitated in twelve minutes. Use a perfectly smooth anode. When it is rough, peroxide, in slight amount, may at the beginning of the experiment appear on it, but it will rapidly go away. The rotation of the anode should be quite rapid, so that the mercury may take up the bismuth which is

deposited quickly, as it often collects in a black mass beneath the anode.

The *rate of precipitation* from this electrolyte is:

In 1 minute.....	0.1305 gram of metal
In 3 minutes.....	0.2274 gram of metal
In 5 minutes.....	0.2515 gram of metal
In 8 minutes.....	0.2732 gram of metal
In 10 minutes.....	0.2751 gram of metal
In 12 minutes.....	0.2775 gram of metal

The substitution of sulphuric for nitric acid makes very little difference in the rate at which bismuth is precipitated:

In 5 minutes.....	0.2409 gram
In 10 minutes.....	0.2764 gram
In 15 minutes.....	0.2770 gram

See also Benner, *J. Am. Ch. S.*, **32**, 1235.

LEAD.

LITERATURE.—Kilian, *Berg-Hütt. Z.*, 1883, 253; Luckow, *Z. f. a. Ch.*, **19**, 215; Richè, *Ann. de Chim. et de Phys.* [5 ser.], **13**, 508; *Z. f. a. Ch.*, **21**, 117; Classen, *ibid.*, 257; Hampe, *Z. f. a. Ch.*, **13**, 183; May, *Am. Jr. Sc. and Ar.* [3 ser.], **6**, 255; also *Z. f. a. Ch.*, **14**, 347; Parodi and Mascazzini, *Ber.*, **10**, 1098; *Z. f. a. Ch.*, **16**, 469; **18**, 588; Richè, *Z. f. a. Ch.*, **17**, 219; Schucht, *Z. f. a. Ch.*, **21**, 488; Tenny, *Am. Ch. Jr.*, **5**, 413; Smith, *Am. Phil. Soc. Pr.*, **24**, 428; Vortmann, *Ber.*, **24**, 2749; Rüdorff, *Z. f. ang. Ch.*, 1892, p. 198; Warwick, *Z. f. anorg. Ch.*, **1**, 258; Classen, *Ber.*, **27**, 163; Kreichgauer, *Ber.*, **27**, 315; *Z. f. anorg. Ch.*, **9**, 89; Classen, *Ber.*, **27**, 2060; Medicus, *Ber.*, **25**, 2490; Neumann, *Ch. Z.* (1896), **20**, 381; Hollard, *B. s. Ch. Paris*, **19**, 911; Linn, *J. Am. Ch. S.*, **24**, 435; Marie, *Ch. Z.*, **24**, 341, 480; Nissenon and Neumann, *Ch. Z.*, **19**, 1143; Elbs and Rixon, *Z. f. Elektrochem.*, **9**, 267; Danneel and Nissenon, *Internationaler Congress für angew. Ch.* (1903), Band **4**, 677; Hollard, *B. s. Ch.*, Series 3, **31**, 5; *Ch. N.*, **89**, 278; Meillère, *J. Phar. Chim.*, [6] **16**, 465; Guess, *Eng. Min. Jr.*, **81**, 328 (1906); Hollard, *Ch. Z.*, **27**, 141 (1903); Exner, *J. Am. Ch. S.*, **25**, 904; R. O. Smith, *J. Am. Ch. S.*, **27**, 1287; Fischer and Boddaert, *Z. f. Elektrochem.*, **10**, 949; Vortmann, *Ann.*, **351**, 283; Sand, *Trans. Ch. Soc.*, **91**, 397 (1907); Sand, *Trans. Faraday Soc.*, **5**, 207 (1910); Benner, *J. Ind. Eng. Ch.*, **2**, 348; Gooch and Beyer, *Am. Jr. S.* [4 Series], **27**, 59; Mathers, *Ch. Z.*, **34**, 1316, 1350.

The metal may be obtained by electrolyzing solutions of the double oxalate (*see* Copper and Cadmium), the acetate, the oxide in sodium hydroxide, or the phosphate dissolved in the latter reagent or in phosphoric acid of 1.7 specific gravity. While the metal separates well from either one of these solutions, difficulty is experienced in drying the deposit, for the moist metal almost invariably suffers a partial oxidation, thus rendering the results high. The deposit can be dried, without oxidation, in an atmosphere of hydrogen, but for the inexperienced operator this procedure offers little satisfaction. It is, therefore, better to utilize the tendency of lead to separate, from acid solutions, as the dioxide. For trial purposes make up a definite volume of lead nitrate. Electrolyze several portions (=0.1 gram lead each) in a platinum dish connected *with the anode*, using a current of $N.D._{100} = 1.5-1.7$ amperes and 2.36 to 2.41 volts. The volume of the electrolyte should be 100 c.c., and its temperature $50^{\circ}-60^{\circ}$. In order that the lead may be precipitated wholly as dioxide upon the positive electrode and none in metallic form upon the cathode, it is necessary that the solution being analyzed should contain 20 c.c. of nitric acid of specific gravity 1.35-1.38. This quantity of acid is required when lead alone is present in solution. To hasten the solution of any metal which may have found its way to the cathode interrupt the current for a short time—five seconds—about the middle of the determination—and again for a brief period before the precipitation is finished. Chlorides must be absent. In the presence of other metals the complete deposition of the lead as dioxide occurs with even less acid. At the end of the precipitation siphon off the acid liquid and wash in the dish, then dry the deposit at $180^{\circ}-190^{\circ}$ C., and weigh. The weight multiplied by 0.866 gives the quantity of metallic lead present. Numerous experiments made in this laboratory showed that the deposits of lead dioxide will weigh too much unless they have been dried for

definite periods at a temperature ranging from 200° – 230° C. It is not probable that the excessive weight is due to the formation of a higher oxide than the dioxide, but to adherent and included water, expelled with difficulty. From a series of results made upon the drying of the dioxide at different temperatures it would seem as if the factor with which to multiply the dioxide should be 0.8643. The deposit can be readily dissolved in nitric acid to which oxalic acid is added, or cover it with dilute nitric acid and insert a rod of zinc or copper. Henz recommends a nitrite solution, acidified with nitric acid, for this purpose. Reference to the literature shows that May preferred, after drying the deposit, to carefully ignite it and finally weigh as lead oxide (PbO). This precipitation of lead as dioxide affords an excellent method by which to separate it from other metals, *e. g.*, mercury, copper, cadmium, silver, and all those soluble in nitric acid, or those which, in a nitric acid solution, are deposited upon the cathode.

Use in these determinations a Classen dish, the inner surface of which has been roughened by having had a sand blast projected against it. The deposition of the dioxide will be much accelerated; *e. g.*, a few hours (4–5) will be sufficient for the precipitation of as much as 4 grams of dioxide upon 100 cm.² surface with a current of 1.5 amperes. Wash with water, then dry as previously directed.

The presence of arsenic in the solution lowers the lead results. When its quantity is very trifling the discrepancy may be disregarded. Selenium has a similar effect.

Lead dioxide, like manganese dioxide (p. 138), is not separated from solutions containing an excess of an alkaline sulphocyanide, and if already precipitated as dioxide, will re-dissolve upon the addition of the sulphocyanide.

In the analysis of lead ores Nissenson and Neumann dissolve 0.5 gram of the material in 30 c.c. of nitric acid of 1.4 specific gravity, boil, dilute with water, filter into a platinum

dish, and electrolyze at 60° – 70° with a current of $N.D._{100} = 1$ ampere and 2.5 volts. The dioxide is washed and dried as indicated above. One hour is sufficient for the precipitation.

The Precipitation of Lead as an Amalgam.

Stähler and Alders recommend the following course: Bring 10 c.c. of lead nitrate solution ($=0.0997$ gram lead) and 10 c.c. of a mercuric chloride solution ($=0.0855$ gram mercury) into a weighed platinum dish and add 1 c.c. of concentrated nitric acid and 1.5 c.c. of phosphoric acid, at the same time warming the solution until it has become perfectly clear. Dilute with water to 125 c.c., let the anode rotate 500 revolutions per minute and electrolyze with a current of $N.D._{100} = 5$ amperes and 10 to 11 volts, which will gradually heat the liquid to 60 – 70° . The lead dioxide which at the beginning separates on the anode will slowly disappear, or it may be well from time to time to interrupt the current for a few seconds. In about twelve minutes ammonium sulphide added to a drop of the electrolyte will produce a very indistinct reaction, although some milligrams of lead still remain unprecipitated. Now carefully add sodium hydroxide (10 per cent. NaOH from metallic sodium) to neutralize the free acid, but do not interrupt the agitation of the solution. When the solution has been just neutralized continue the electrolysis for a few minutes, pour off the liquid as rapidly as possible and wash the amalgam with water, alcohol and ether. Then dry in a desiccator and weigh. The results are very good.

The Rapid Precipitation of Lead Dioxide With the Use of a Rotating Electrode.

Exner added 20 c.c. of concentrated nitric acid to a solution of lead nitrate, giving a total volume of about 125 c.c., and acted upon the same with a current of $N.D._{100} = 10$ amperes and 4.5 volts. The rotating electrode (cathode) per-

formed 600 revolutions per minute. The deposits had a uniform velvety black color. There was no tendency on the part of the deposit to scale off, though more than a gram of the dioxide was precipitated. The time varied from ten to fifteen minutes. A platinum dish with sand-blasted inner surface was used as anode.

R. O. Smith, in using a current of $N.D._{100} = 11$ amperes and 4 volts upon a solution of lead nitrate containing 0.4996 gram of lead or 0.5787 gram of dioxide, found the *rate of precipitation* to be:

In 5 minutes.....	0.4940 gram lead dioxide
In 10 minutes.....	0.5708 gram lead dioxide
In 15 minutes.....	0.5747 gram lead dioxide
In 20 minutes.....	0.5770 gram lead dioxide
In 25 minutes.....	0.5787 gram lead dioxide
In 30 minutes.....	0.5789 gram lead dioxide

The maximum time period for a quarter of a gram of metal is fifteen minutes, and the maximum time for a half-gram of metal is twenty-five minutes.

SILVER.

LITERATURE.—Luckow, Ding. p. Jr., **178**, 43; Z. f. a. Ch., **19**, 15; Fresenius and Bergmann, Z. f. a. Ch., **19**, 324; Krutwig, Ber., **15**, 1267; Schucht, Z. f. a. Ch., **22**, 417; Kinnicutt, Am. Ch. Jr., **4**, 22; Rüdorff, Z. f. ang. Ch., Jahrg. 1892, p. 5; Eisenberg, Thesis, Heidelberg, 1895; Smith, Am. Ch. Jr., **12**, 335; Fulweiler and Smith, J. Am. Ch. S., **23**, 583; Exner, J. Am. Ch. S., **25**, 900; Gooch and Medway, Am. Jr. Sciences, **15**, 320; *ibid.*, Ch. N., **87**, 284; Kollock and Smith, J. Am. Ch. S., **27**, 1536; Langness, J. Am. Ch. S., **29**, 464; Fischer and Boddaert, Z. f. Elektrochem., **10**, 949; Gooch and Feiser, Am. Jr. Science [4 Series], **31**, 109; Hughes and Withrow, J. Am. Ch. S., **32**, 1571; Benner and Ross, J. Am. Ch. Soc., **33**, 1106.

The experiments of Luckow showed that this metal could be deposited from solutions containing as high as 8 to 10

per cent. of free nitric acid. The deposit was spongy, and there was a simultaneous deposition of silver peroxide at the anode. This was, however, prevented by adding to the solution some glycerol, lactic or tartaric acid. A voluminous mass was also obtained from silver solutions, containing an excess of ammonium hydroxide or carbonate, and peroxide appeared at the same time upon the anode.

Fresenius and Bergmann, who have given the electrolysis of acid solutions of silver particular study, observed that the tendency of the metal to sponginess is most marked when the electrolyte is concentrated and acted upon by a strong current.

In a dilute liquid, the current being feeble, the deposit was compact and metallic in appearance (free acid should be present). From neutral solutions, although very dilute, the metal is separated in a flocculent condition by the feeblest currents. Therefore, to obtain results that would answer for quantitative analysis, the following conditions were adopted: The total dilution of the solution was 200 c.c.; in this there were 0.03–0.04

gram of silver, and 3–6 grams of free nitric acid. The poles were separated about 1 cm. from each other, while the current at 50°–60° was $N.D._{100} = 0.04-0.05$ ampere, and at the ordinary temperature it was $N.D._{100} = 0.1-0.2$ ampere and 2 volts.

In the experiments of Fresenius and Bergmann apparatus similar to that in Fig. 31 was employed. It has some decided advantages. Both spiral (*a*) and cone (*b*) are constructed of platinum. The metallic deposition, it will be understood, occurs upon the cone, the sides of which are perforated, so

FIG. 31.

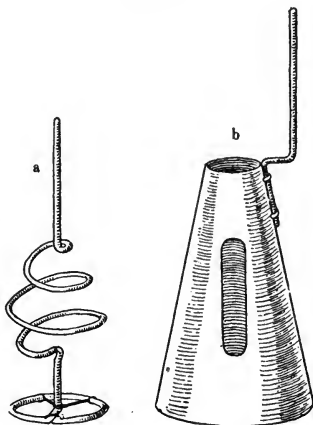

that a uniform concentration of liquid is preserved throughout the decomposition. When liquid electrolytes contain much iron, it is essential that the oxygen liberated within the cone should be equally distributed over its outer surface. This is made possible through openings. The shape of the cone also prevents loss from the bursting of the bubbles arising from the platinum spiral in connection with the anode.

Krutwig advises adding a large excess of ammonium sulphate to the silver solution, previously made alkaline with ammonium hydroxide, and employs a current of $N.D._{100} = 0.02-0.05$ ampere and 2.5 volts. In this way, 0.1 gram of silver may be precipitated in two hours.

The writer's experience has chiefly been with solutions of silver containing an excess of a pure alkaline cyanide. With these peroxide separation does not occur, and a very weak current will precipitate 0.15-0.20 gram of metal in ten hours from a cold solution. If the liquid be heated to $65^{\circ} C.$, during the decomposition, as much as 0.2-0.3 gram of metal may be precipitated in three and one-half hours. The current density for this precipitation should be $N.D._{100} = 0.07$ ampere. Several examples from a student's notebook will show how well the method works:—

	SILVER. GRAM.	DILUTION. C.C.	POTASSIUM CYANIDE. GRAMS.	CURRENT. N.D. ₁₀₀ .	VOLTS.	TEMPERA- TURE.	TIME HOURS.	SILVER FOUND. GRAM.
1	0.2133	125	2	0.03 A	2.5	65°	4	0.2132
2	0.2133	125	2	0.03 A	2.5	60	3	0.2133
3	0.2133	125	4	0.04 A	2.5	60	3	0.2131
4	0.2133	125	2	0.025A	2.7	60	4	0.2134
5	0.2133	125	2	0.025A	2.7	60	3	0.2135
6	0.2133	125	2	0.025A	2.7	60	4	0.2125

In trials 1 and 2 the metal was precipitated upon a dish, while in 3 and 4 a plate cathode, and in 5 and 6 a cone, was used to receive the silver, which was very adherent, and

brilliant in lustre. It was washed with water, alcohol, and ether.

Chlorine, bromine, and iodine can be indirectly estimated electrolytically by first precipitating them as silver salts, then dissolving the latter in potassium cyanide, and exposing the resulting solution to the action of a current from three to four "Crowfoot" cells.

Luckow reduced silver chloride by placing it in a platinum dish, serving as the negative electrode, covering it with dilute sulphuric or acetic acid, and allowing the positive electrode to project into the solution. Four Meidinger cells were strong enough to reduce 0.1 gram of silver chloride in ten minutes. The deposit, while spongy, was adherent. It was washed with water and then thoroughly dried to insure the absence of any acid. (See the reference to Kinnicutt's experiments; also, Prescott and Dunn, Jr. *An. Ch.*, 3, 373.)

The Rapid Precipitation of Silver With the Use of a Rotating Anode.

To a solution of silver nitrate, containing 0.4990 gram of metal, add 2 grams of potassium cyanide, heat the solution (125 c.c.) almost to boiling and electrolyze with a current of $N.D._{100}=2$ to 2.8 amperes and 5 volts. The metal will be precipitated in the form of a dense white deposit in nine to ten minutes. Have the anode perform 700 revolutions per minute.

The *rate of precipitation*, with a flat spiral anode, from this electrolyte was as follows:

In 1 minute.....	0.2046 gram
In 2 minutes.....	0.3391 gram
In 3 minutes.....	0.4858 gram
In 4 minutes.....	0.5043 gram
In 5 minutes.....	0.5225 gram
In 7 minutes.....	0.5270 gram
In 10 minutes.....	0.5301 gram

By using the *dish anode* described on p. 78 the 0.53 gram of silver present was precipitated in two minutes, all but a very small quantity being deposited in the first minute. Thus with 5 volts and 9 to 10 amperes the *rate of precipitation* was:

In 1 minute.....	0.5116 gram
In 2 minutes.....	0.5304 gram
In 3 minutes.....	0.5306 gram
In 4 minutes.....	0.5306 gram

One fails to see how any gravimetric method followed in the precipitation of silver could give results like the preceding. The time factor is almost eliminated. Every part of the procedure is satisfactory.

Gooch and Medway also obtained very excellent determinations of silver by depositing it upon a rotating cathode (p. 46).

The Rapid Precipitation of Silver With the Use of a Rotating Anode and Mercury Cathode.

In determining silver in this manner have it in the form of nitrate. An example will illustrate the best conditions. To 5 c.c. of silver nitrate solution (=0.2240 gram of silver) add 5 drops of nitric acid (30 drops equaled 1 c.c.). Rotate the anode at a speed of 1200 revolutions per minute. At the end of five minutes the precipitation will be complete. Then proceed as directed in all determinations made in this way.

An anodic deposit will show itself in the first minute or two, but it will entirely disappear in four or five minutes. The anode should have a high speed to insure agitation of the mercury, thereby making the absorption of silver more certain. It is not advantageous to have a greater concentration than 0.3500 gram of silver in 5 cubic centimeters.

The *rate of precipitation* in this electrolyte was:

In 1 minute.....	0.1874 gram of silver
In 2 minutes.....	0.2178 gram of silver
In 3 minutes.....	0.2207 gram of silver
In 4 minutes.....	0.2240 gram of silver

Consult Benner, *J. Am. Ch. S.*, **32**, 1233.

ZINC.

LITERATURE.—Wrightson, *Z. f. a. Ch.*, **15**, 303; Parodi and Mascazzini, *Ber.*, **10**, 1098; *Z. f. a. Ch.*, **18**, 587; Richè, *Z. f. a. Ch.*, **17**, 216; Beilstein and Jawein, *Ber.*, **12**, 446; *Z. f. a. Ch.*, **18**, 588; Richè, *Z. f. a. Ch.*, **21**, 119; Reinhardt and Ihle, *Jr. f. pkt. Ch. [N. F.]*, **24**, 193; Classen and v. Reiss, *Ber.*, **14**, 1622; Gibbs, *Z. f. a. Ch.*, **22**, 558; Luckow, *Z. f. a. Ch.*, **25**, 113; Brand, *Z. f. a. Ch.*, **28**, 581; Warwick, *Z. f. anorg. Ch.*, **1**, 258; Vortmann, *Ber.*, **24**, 2753; Rüdorff, *Z. f. ang. Ch.*, Jahrg. **1892**, 197; Vortmann, *M. f. Ch.*, **14**, 536; v. Malapert, *Z. f. a. Ch.*, **26**, 56; Herrick, *Jr. An. Ch.*, **2**, 167; Jordis, *Z. f. Elektrochem.*, **2**, 138, 563, 655; Millot, *B. s. Ch. Paris*, **37**, 339; v. Foregger, *Dissertation*, Bern, 1896; Riderer, *J. Am. Ch. S.*, **21**, 789; Nicholson and Avery, *J. Am. Ch. S.*, **18**, 659; Paweck, *Berg-Hütt. Z.*, **46**, 570-573; Paweck, *Ch. Z.* (1900), **24**, No. 80; Hollard, *B. s. Ch. Paris* (Series 3), **29**, 262; *Ch. N.* (1903), **87**, 259; Amberg, *Ber.*, **36**, 2489 (1903); Spitzer, *Z. für Elektrochem.*, **11**, 391; Currie, *Ch. N.*, **91**, 247; Danneel and Nissenson, *Internationaler Congress für angew. Ch.* (1903), **4**, 679; Price and Judge, *Ch. N.*, **94**, 18; Ingham, *J. Am. Ch. S.*, **26**, 1269; Jene, *Ch. Z.*, **29**, 801; Exner, *J. Am. Ch. S.*, **25**, 899; Langness, *J. Am. Ch. S.*, **24**, 463; Kollock and Smith, *Am. Phil. Soc. Pr.*, **xliv**, 137 (1905); Fischer and Boddaert, *Z. f. Elektrochem.*, **10**, 946; Foerster, *Z. f. angew. Ch.*, **19**, 1889 (1906); Kollock and Smith, *Am. Phil. Soc. Pr.*, **45**, 256; Frary, *J. Am. Ch. Soc.*, **29**, 1596; Neumann, *Z. f. Elektroch.*, **13**, 751; Price, *Ch. N.*, **97**, 89; Smalley, *Trans. Faraday Soc.*, **6**, 208; Spear, Wells and Dyer, *Jr. Am. Ch. S.*, **32**, 530; Kollock and Smith, *Trans. Am. Electroch. S.*, **14**, 59; Kemmerer, *J. Ind. and Eng. Ch.*, **2**, 375.

Much has been written upon the electrolytic estimation of zinc. The early suggestion of Parodi and Mascazzini has met with a most favorable reception. They recommended that the metal be present in solution as sulphate; its quantity may vary from 0.1–0.25 gram. To it add 4 c.c. of a solution

of ammonium acetate, 20 c.c. of citric acid, and dilute to 200 c.c. with water. The electrodes are then introduced into the liquid, their distance apart being not more than a few millimeters. The precipitation can be made in a beaker, using a weighed platinum cone (Fig. 31) as the cathode. The current for this purpose should be 0.5 ampere and 5.9–6.3 volts. At 50° – 60° , with a current of 0.5 ampere, the pressure will be 4.8–5.2 volts and the deposit of metal will be most satisfactory. When the precipitation of metal has ended, which may be ascertained by removing a small quantity of the liquid with a capillary tube and bringing it in contact with a drop of a solution of potassium ferrocyanide, remove the bulk of the liquid with a siphon. Wash the deposit with water and alcohol. There is no danger of oxidation during the drying process. It will be discovered on dissolving the precipitated zinc that the platinum is covered with a black powdery layer, insoluble even in hot hydrochloric or hot nitric acid. This is platinum black (Vortmann, Rüdorff). It is exceedingly difficult to remove, and to prevent its occurrence it is well to coat the platinum dish with a thin layer of copper or silver before precipitating the zinc (p. 117). In this laboratory constant use is made of nickel dishes or nickel gauzes in determinations of zinc. The zinc deposits are removed most readily by the addition of dilute sulphuric acid (1:25). The nickel cathode loses but little weight by this treatment. These electrodes have proven of great help in the rapid analysis of zinc salts.

Beilstein and Jawein add sodium hydroxide to the solutions of zinc nitrate or sulphate, until a precipitate is produced, dissolve it in potassium cyanide, and dilute with water to 150 c.c. The decomposition is carried out in a rather large beaker, the cathode being either the platinum cone already described (p. 109), or a rather large platinum crucible suspended from a cork, perforated by a copper wire, touching

the inner surface of the crucible. If the decomposition takes place at the ordinary temperature, use a current of $N.D._{100} = 0.5$ ampere and 5.8 volts. The precipitation will be complete in from two to two and one-half hours. It may be reduced to one and one-half to one and three-quarter hours by heating the electrolyte to 60° and applying a current of the density just given and 5 volts. Wash the deposit as instructed above.

Reinhardt and Ihle have objected to nearly all the methods which have been proposed for the electrolytic estimation of zinc. They say of the Beilstein and Jawein method . . . that the results are fairly good, . . . but a strong current is necessary, otherwise the precipitation of the zinc is slow and incomplete, . . . the positive pole diminishes in weight very appreciably, . . . finally, working with potassium cyanide is very unpleasant. The writer's experience has proved that a current considerably less than that which Beilstein and Jawein first recommended will throw out all the zinc in the course of a night, and further that the anode is not appreciably affected. The method suggested by Reinhardt and Ihle is, however, very excellent and deserves trial by all interested in the electrolytic estimation of zinc. Its essential features, taken from their publication, are these: Mix the solution of zinc sulphate or chloride, neutral as possible, with an excess of neutral potassium oxalate, until the precipitate, which appears at first, redissolves. Or, observing the recommendation of Classen, add 4 grams of potassium or ammonium oxalate to the solution, acidulate the latter with tartaric acid (3 : 50), dilute to 150 c.c. with water, heat to 60° , and electrolyze in copper-coated platinum dishes with $N.D._{100} = 0.5-1.5$ amperes and 3.5-3.8 volts. Two hours will be sufficient for complete precipitation.

The immediate decomposition of the zinc oxalate is into zinc and carbon dioxide (two molecules), and the potassium oxalate into carbon dioxide (two molecules) and potassium;

the latter then reacts with the water, so that while an abundant liberation of hydrogen occurs at the cathode, the alkali simultaneously set free is converted into acid potassium carbonate by the carbon dioxide at the anode:

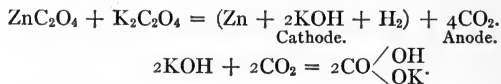

Therefore, just as long as zinc oxalate is being decomposed, considerable evolution of gas is noticeable at the positive electrode, and when this diminishes, and occasional bubbles escape, the decomposition is complete, and the deposition of metal may be considered finished.

Free oxalic acid, or any other acid, is not injurious if there is a sufficient quantity of potassium oxalate present. Nitric acid, however, free or combined, should be avoided; it gives rise to ammonium salts, which prevent the zinc from separating in a dense form. The acid potassium carbonate produced during the decomposition offers great resistance to the current; it is, therefore, advisable to add potassium sulphate to the solution to increase its conductivity. Reinhardt and Ihle recommend the following solutions for use in decompositions like that just described: 166 grams of potassium oxalate in 1 liter of water; 250 grams of potassium sulphate in 1 liter of water, and a solution of oxalic acid saturated at 15° C.

Experiments.—(1) 40 c.c. of a solution of zinc sulphate (=0.1812 gram of metallic zinc), to which were added 50 c.c. of potassium oxalate and 100 c.c. of potassium sulphate, were electrolyzed with a current of N.D.₁₀₀=0.3 ampere and 3.9–4.2 volts, at the ordinary temperature. After three to four hours the current was interrupted. The precipitated zinc weighed 0.1814 gram. (2) 2.1867 grams of brass (containing tin, copper, lead, and zinc) were dissolved in nitric acid and the tin determined in the usual gravimetric way.

Its quantity was found to be 0.04 per cent. In the filtrate, containing nitric acid, lead and copper were determined simultaneously by electrolysis (the copper separated upon the cathode and the lead as dioxide upon the anode):—

$$\text{Found } \begin{cases} a - 0.85\% \text{ Pb and } 64.60\% \text{ Cu.} \\ b - 0.85\% \text{ Pb and } 64.62\% \text{ Cu.} \end{cases}$$

The acid liquid was siphoned off from the deposits, evaporated to dryness with sulphuric acid, neutralized with caustic potash, and then to this (100 c.c. in volume) solution were added 50 c.c. of a solution of potassium oxalate and 100 c.c. of a solution of potassium sulphate. The zinc found equaled 34.50 per cent.

When using this method employ a stout platinum wire, wound to a spiral at the one end, for the anode, and a platinum cone for the cathode (p. 109). To avoid the peculiar spots which electrolytic zinc shows upon a platinum surface, it will be best to first coat the negative electrode with copper (5 grams). In dissolving the precipitated zinc, use rather dilute nitric acid. The copper layer will be but slightly attacked, and after washing and drying will serve for further depositions. Wash the zinc deposit with water, alcohol, and ether; dry in a desiccator. Oxidation is liable to occur if an air-bath be used for the drying.

Jordis prefers lactic to oxalic acid in the electrolysis of zinc salts. To the solution containing 0.2 gram of metallic zinc he added 5 grams of ammonium lactate, 2 grams of lactic acid, and 5 grams of ammonium sulphate. The liquid was diluted to 230 c.c. and acted upon at 60° with a current of $N.D._{100} = 0.10-0.23$ ampere and 3.4-3.9 volts. The electrolyte was usually agitated. The anode and cathode were 1.5 cm. apart. The time for complete precipitation occupied four and a quarter hours. A copper-plated platinum dish was used as cathode.

Nicholson and Avery, adopting the suggestion of War-

wick, add 3 c.c. of formic acid to the zinc salt solution, then nearly neutralize with sodium carbonate, dilute to 150 c.c., and electrolyze at the ordinary temperature with a current varying from 0.5 to 1 ampere.

Millot, Kiliani, and v. Foregger use sodium zincate as electrolyte, giving the following example: To the solution of 1 gram of zinc sulphate add 2 to 4 grams of sodium hydroxide, dilute to 125 c.c. with water, heat to 50°, and electrolyze with $N.D._{100} = 0.7-1.5$ amperes and 3.9-4.5 volts. All of the metal will be deposited in two hours. The character of the deposit is improved with the increase in the quantity of sodium hydroxide. In applying this method to the determination of zinc in its ores, Jene proceeds as follows: Dissolve 0.5 gram of the ore in aqua regia, evaporate to dryness, add 1 to 2 c.c. of sulphuric acid (1 : 1), which expel by heat. When the mass is cold, add water, boil, filter and wash the residue with hot water. The filtrate should not exceed 80 to 100 c.c. in volume. It is ready for electrolysis. Add to it 4 to 7 grams of solid sodium hydroxide, allowing the latter to dissolve completely. Heat to 50° C., and electrolyze. Use a copper-plated platinum dish with $N.D._{100} = 1$ ampere and a pressure of from 3.8 to 4.2 volts. The deposition will be finished in from 1½ to 2 hours. The end of the decomposition is ascertained by suspending a perfectly clean strip of sheet copper over the edge of the dish and observing whether, after fifteen minutes, it has become coated with any zinc.

Richè employs "a solution of the acetate with an excess of ammonium acetate, obtained by supersaturation with ammonia and acidifying with acetic acid." This method affords good results, as may be seen from the following determination: 0.4736 gram of zinc sulphate was dissolved in 200 c.c. of water, to which were added 3 grams of sodium acetate and 10 drops of ordinary acetic acid. When there is an insufficiency of acetic acid, the zinc deposit becomes spongy.

Ammonium acetate may be substituted for the sodium salt. After two hours 0.1063 gram of metallic zinc was obtained, the required quantity being 0.1072 gram. The temperature should be 60° and the current $N.D._{100} = 0.5$ ampere and 4.8–5.2 volts.

Moore seems to have obtained exceedingly satisfactory results by precipitating a solution of zinc sulphate with sodium phosphate, then adding an excess of ammonium carbonate, and after dissolving the precipitate in potassium cyanide, the solution was electrolyzed at a temperature of 80°. (See method of Beilstein and Jawein.) The metal was deposited upon a silver-plated electrode. An excellent procedure, originating with Luckow and previously noticed in the Historical section, consists in introducing 0.5 gram of metallic mercury into the dish in which it is intended to electrolyze the solution of the zinc salt. It is, of course, understood that the platinum dish and the drop of mercury are weighed together. A zinc amalgam is precipitated; it distributes itself in a beautiful adherent layer over the surface of the dish.

Paweck believes that in the amalgam method suggested by Vortmann much inconvenience is experienced in weighing out the mercuric chloride and subsequently re-calculating it into metal; further, that by frequent use the surface of the platinum cathode changes to spongy platinum, thus giving rise to considerable loss. To avoid these disadvantages he suggests the use of amalgamated zinc or brass electrodes in gauze form. The introduction of these eliminates the addition of a mercury salt, while the gauze form favors the deposition and prevents the collection of hydrogen bubbles on the under side of the cathode, whereby a spongy zinc deposit is likely to be produced. The gauze electrodes are semi-cylindrical in shape, 6 cm. in diameter, two being attached to a brass rod at a distance of 12 mm. After they have been cleaned, they are amalgamated or coated with mercury by electrolyzing a

solution containing 0.6 gram of mercuric chloride. The amalgam is washed with alcohol, ether, dried and weighed. The electrolyte contains the zinc salt, Seignette salt and alkali. It may be electrolyzed with a current of 0.1-0.5 ampere and 2.6-3.6 volts. The deposit should be dried at 30°-40°. (See p. 71.)

Vortmann has found that zinc may be readily precipitated from its solution in the presence of an excess of sodium hydroxide and sodium tartrate. The deposit is gray in color and adheres well to the dish. The current density (N.D.₁₀₀) may vary from 0.3-0.6 ampere. To determine when the precipitation is complete, remove a few drops of the liquid and warm with ammonium sulphide.

The Rapid Precipitation of Zinc With the Use of the Rotating Anode.

In an *alkaline electrolyte* (NaOH) proceed as follows:

To 25 c.c. of solution (=0.2490 gram of zinc) add 8 grams of solid sodium hydroxide, dilute to 125 c.c. with water, heat almost to boiling, then remove the flame and electrolyze with N.D.₁₀₀=5 amperes and 6 volts. The anode should make about 600 revolutions per minute. The precipitation will be complete in twenty minutes. The deposit will be adherent, smooth, hard and gray in color. The amount of sodium hydroxide may vary within quite wide limits. Or, add sufficient sodium hydroxide to precipitate all the zinc as hydroxide and then enough cyanide to dissolve the precipitate. Introduce into this solution 20 c.c. of ammonium hydroxide of specific gravity 0.96 and electrolyze with a current of 2 amperes and a pressure of 5 volts. The zinc will be completely precipitated in from 15 to 30 min. (J. Am. Ch. S., 32, 1474).

The *rate of precipitation* of zinc from the sodium hydroxide electrolyte, using a current of 5 amperes and 8 volts, was:

In 1 minute.....	0.1028 gram
In 2 minutes.....	0.1847 gram
In 3 minutes.....	0.2921 gram
In 4 minutes.....	0.3498 gram
In 5 minutes.....	0.4217 gram
In 7 minutes.....	0.4691 gram
In 10 minutes.....	0.4740 gram
In 12 minutes.....	0.4780 gram
In 15 minutes.....	0.4780 gram

See J. Am. Ch. S., 32, 530 and 533.

In an *alkaline acetate electrolyte* the deposition is also very rapid. An example will show this—

A solution of zinc sulphate, equivalent to 0.5004 gram of metal, containing 3 grams of sodium acetate and 0.2 c.c. of acetic acid (30 per cent.), was diluted with water to 125 c.c. and electrolyzed with a current of $N.D._{100} = 4$ amperes and 10 volts. In fifteen minutes 0.5002 gram of zinc was precipitated on the silver-plated platinum dish. The deposit was light blue in color and crystalline. The anode performed 600 revolutions per minute.

Ingham determined the *rate of precipitation* of zinc from this electrolyte:

In 1 minute.....	0.0933 gram
In 2 minutes.....	0.1500 gram
In 3 minutes.....	0.2326 gram
In 4 minutes.....	0.2957 gram
In 5 minutes.....	0.3773 gram
In 7 minutes.....	0.4645 gram
In 10 minutes.....	0.4736 gram
In 15 minutes.....	0.4766 gram
In 20 minutes.....	0.4779 gram

when the amount of metal in the electrolyte equaled 0.4780 gram.

The *formate electrolyte* was prepared as follows:

To the salt solution (=0.2490 gram of zinc) were added 5 grams of sodium carbonate and 4.6 c.c. of formic acid, sp. gr.

1.22. The solution was diluted with water to 125 c.c., heated to boiling and acted upon with a current of $N.D._{100} = 5$ amperes and 8 volts. In twenty minutes the entire amount of metal was precipitated. The deposit was fine-grained and very adherent.

The *rate of precipitation* was found to be:

In 1 minute.....	0.0839 gram of metal
In 2 minutes.....	0.1418 gram of metal
In 3 minutes.....	0.1723 gram of metal
In 5 minutes.....	0.2095 gram of metal
In 7 minutes.....	0.2244 gram of metal
In 10 minutes.....	0.2464 gram of metal
In 12 minutes.....	0.2483 gram of metal
In 15 minutes.....	0.2490 gram of metal
In 20 minutes.....	0.2490 gram of metal

In an *ammoniacal electrolyte* it is possible to precipitate the metal very satisfactorily by using a rotating anode. It is well established that with stationary electrodes the same electrolyte is impracticable. To use it proceed in the following manner:

Add to the zinc salt solution 5 c.c. of hydrochloric acid (sp. gr. 1.21), 25 c.c. of ammonium hydroxide (sp. gr. 0.95) and one gram of ammonium chloride. Let the total dilution be 125 c.c. Electrolyze with $N.D._{100} = 5$ amperes and 5 volts. In twenty minutes a quarter of a gram of metal will be fully precipitated. The deposit will be all that one can wish. There is no likelihood of the anode's being attacked by the chlorine. This electrolyte can be used in estimating the zinc content of zincblende. Weigh off 0.5 gram of the powdered ore into a No. 5 porcelain dish, moisten it with water, add nitric acid (sp. gr. 1.41) sufficient to cover it and digest upon an iron plate. In about twenty minutes after action has ceased, raise the cover enough to let the fumes escape and rapidly evaporate the liquid to dryness. Cover the residue with pure hydrochloric acid (sp. gr. 1.21) and again evaporate

to dryness. Repeat the treatment with hydrochloric acid, taking care to avoid overheating and volatilization of any chloride. Finally, moisten the dry salts with strong hydrochloric acid and take up with hot water. This operation need not require more than an hour and ten minutes. Having filtered out the gangue, precipitate the iron with ammonium hydroxide, receiving the filtrate from it in the customary silvered and weighed platinum dish, the precipitate not being washed with water, but after the substitution of a porcelain vessel for the platinum the iron hydrate should be dissolved from off the moist filter in warm dilute acid and reprecipitated with ammonium hydroxide. Two precipitations will be necessary to free the iron completely from zinc. To the solution in the platinum dish add 0.5 gram of ammonium chloride, preferably in the dry form, and electrolyze the solution (125 c.c. in volume) with a current of 5 amperes and 6 volts. Twenty minutes are sufficient for the precipitation. The deposit will be crystalline, adherent but not spongy.

By this method the zinc content of a blende may be made in a little more than two hours from the time of weighing off the powdered ore to the weighing of its zinc content.

If the iron in the ore, after removal of the gangue, is precipitated as the basic acetate or formate, the filtrate from it can be used for the electrolytic determination of the zinc, using the rotating anode. The results will be most satisfactory.

The Rapid Precipitation of Zinc With the Use of the Rotating Anode and Mercury Cathode.

This metal is especially readily determined in this manner. Perhaps no better evidence of this can be given than may be found in the accompanying table, where varying conditions are presented in detail.

ZINC.

EXP. No.	ZINC PRESENT IN GRAMS.	SULPHURIC ACID PRESENT IN C.C.	VOLUME IN C. C.	CURRENT AMPERES.	VOLTS.	REVOLUTIONS OF ANODE PER MINUTE.	TIME IN MINUTES.	ZINC FOUND IN GRAMS.	ERROR IN GRAMS.
1	0.2025	0.00	15	1	7	750	30	0.2027	+0.0002
2	0.2025	0.00	15	7	7	750	25	0.2030	+0.0005
3	0.2025	0.00	15	1	7	750	25	0.2015	-0.0010
4	0.2025	0.00	15	1	7	750	25	0.2020	-0.0005
5	0.2025	0.00	15	1	7	750	25	0.2025	—
6	0.2025	0.00	10	2	7	750	25	0.2024	-0.0001
7	0.2025	0.25	10	2	7	750	30	0.2027	+0.0002
8	0.4040	0.25	20	1.5	6	750	45	0.2054	+0.0004
9	0.2025	0.25	10	1	5	750	25	0.2025	—
10	0.2025	0.25	10	1	5	750	25	0.2029	+0.0004
11	0.2025	0.25	15	1	5	750	25	0.2025	—
12	0.2025	0.25	15	1	5	750	20	0.2027	+0.0002
13	0.2025	0.25	15	2	6	750	15	0.2030	+0.0005
14	0.2025	0.25	15	2	6	750	15	0.2020	-0.0005
15	0.2025	0.25	15	2	6	750	15	0.2021	-0.0004
16	0.4050	0.25	15	5	8	1,400	6	0.4057	+0.0007
17	0.4050	0.25	15	5	8	480	6	0.4045	-0.0005
18	0.4050	0.25	15	5-6	7-5	480	8	0.4042	-0.0008
19	0.4050	0.25	10	5	7	640	5	0.4050	—

The rate of precipitation is interesting:

With a current of one ampere and five volts acting upon 15 c.c. of a zinc sulphate solution, containing 0.2025 gram of metal, there was precipitated:

In 5 minutes.....	0.1196 gram
In 10 minutes.....	0.1774 gram
In 15 minutes.....	0.1897 gram
In 20 minutes.....	0.2002 gram
In 25 minutes.....	0.2027 gram

With a like volume of solution, to which had been added 0.4 c.c. of concentrated sulphuric acid, a current of two amperes and seven volts precipitated:

In 5 minutes.....	0.1860 gram of zinc
In 10 minutes.....	0.1998 gram of zinc
In 15 minutes.....	0.2020 gram of zinc

On dissolving double the quantity of zinc in 15 c.c., adding 0.25 c.c. of concentrated sulphuric acid, a current of 1.5 amperes and 10 volts, and an anode rotating at the rate of 800 revolutions per minute, precipitated:

In 10 minutes.....	0.3701 gram
In 15 minutes.....	0.3997 gram
In 20 minutes.....	0.4011 gram
In 30 minutes.....	0.4058 gram

The same mass of zinc in twenty cubic centimeters was electrolyzed with a current of 2 amperes and 6 volts, other conditions being identical, at this rate:

In 10 minutes.....	0.3352 gram
In 15 minutes.....	0.4010 gram
In 20 minutes.....	0.4030 gram
In 30 minutes.....	0.4050 gram

An anode rotating at 440 revolutions per minute and again at 1000 revolutions made no apparent difference in the rate at which the metal was deposited. The mercury should not be allowed to accumulate too much of the metal. If too much zinc be present in the amalgam, it has a tendency to oxidize and adhere to the walls of the tube. The latter may cause possible loss in washing. Concentration of the electrolyte is most favorable to rapid and satisfactory depositions of the zinc metal.

As stated under the use of the mercury cathode (p. 65) there are those who have modified its form and there are those who have questioned its utility with certain metals. Perhaps the determination of no one metal in this way has been the subject of so much adverse criticism as has that of zinc, and yet in this laboratory there is absolute confidence in the scheme. It is justified by experience and by a study of all criticisms with an absolutely open mind, the single desire being to reach the truth, if not through our own efforts then

through those of others. Accordingly, we return to our original procedure, asking analysts to follow the course which has been set forth on p. 65. If this be observed the analyst may be assured there will be no loss of mercury mechanically in washing, or of zinc chemically by solution in the acid electrolyte, or that zinc hydroxide will be formed and carried away in the wash water. The amalgam need not be dried in a vacuum. A study of the contribution on the determination of zinc with the mercury cathode and rotating anode as it appeared in the *Trans. Am. Electroch. S.*, **14**, 59, will be most helpful.

NICKEL AND COBALT.

LITERATURE.—Gibbs, *Z. f. a. Ch.*, **3**, 336; *Z. f. a. Ch.*, **11**, 10; **22**, 558; Merrick, *Am. Ch. J.*, **2**, 136; Wrightson, *Z. f. a. Ch.*, **15**, 300, 303, 333; Schweder, *Z. f. a. Ch.*, **16**, 344; Cheney and Richards, *Am. Jr. Sc. and Ar.* [3], **14**, 178; Ohl, *Z. f. a. Ch.*, **18**, 523; Luckow, *Z. f. a. Ch.*, **19**, 16; Bergmann and Fresenius, *Z. f. a. Ch.*, **19**, 314; Richè, *Z. f. a. Ch.*, **21**, 116, 119; Classen and v. Reiss, *Ber.*, **14**, 1622, 2771; Schucht, *Z. f. a. Ch.*, **22**, 493; Kohn and Woodgate, *J. Soc. Ch. Ind.*, **8**, 256; Rüdorff, *Z. f. ang. Ch.*, Jahrg. 1892, p. 6; Brand, *Z. f. a. Ch.*, **28**, 588; Le Roy, *C. r.*, 112, 722; Vortmann, *M. f. Ch.*, **14**, 536; v. Foregger, *Dissertation*, 1896, Bern; Campbell and Andrews, *J. Am. Ch. S.*, **17**, 125; Oettel, *Z. f. Elektrochem.*, **1**, 192; Fresenius and Bergmann, *Z. f. a. Ch.*, **19**, 320; Foerster, *Z. f. Elektrochem.*, **6**, 160; Winkler, *Z. f. anorg. Ch.*, **8**, 291; Hollard, *B. s. Ch. Paris* [Series 3], **29**, 22; Danneel and Nissenon, *Internationaler Congress für angew. Ch.* (1903), **4**, 679; Perkin and Preble, *Ch. N.*, **90**, 307; Exner, *J. Am. Ch. S.*, **25**, 899; Smith, *J. Am. Ch. S.*, **26**, 1595; Kollock and Smith, *Am. Phil. Soc. Pr.* (1905), **44**, 137; Fischer and Boddaert, *Z. f. Elektrochem.*, **10**, 946; Foerster, *Z. f. angew. Ch.*, **19**, 1889 (1906); Schumann, *Z. f. angew. Ch.*, **21**, 2579; A. Fischer, *Z. f. angew. Ch.*, **20**, 134; Kollock and Smith, *Am. Phil. Soc. Pr.*, **45**, 262; Fischer, *Z. f. Elektrochem.*, **13**, 361; Thiel, *Z. f. Elektroch.*, **14**, 201; Lambris, *Z. f. Elektroch.*, **15**, 973; Benner and Hartmann, *J. Am. Ch. S.*, **32**, 1628; Benner and Ross, *J. Am. Ch. S.*, **33**, 493; Bruylants, *Bull. Soc. belg. Chim.*, **23**, 383; *Ann. Chim. anal.*, **15**, 57.

These metals are precipitated from solutions of their double cyanides, double oxalates, and sulphates mixed with alkaline

acetates, tartrates, and citrates, or from ammoniacal solutions. The latter seem best adapted for nickel depositions, the presence of ammonium sulphate or sodium phosphate being favorable to the precipitation.

Fresenius and Bergmann, who have carried out a series of experiments with nickel and cobalt, give the following as satisfactory conditions: 50 c.c. nickel solution (=0.1233 gram of nickel), 100 c.c. of ammonia (sp. gr. 0.96), 10 c.c. of ammonium sulphate (305 grams of the salt in 1 liter of water), 100

FIG. 32.

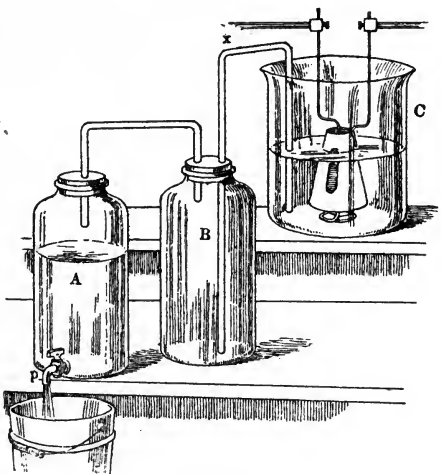

c.c. of water; separation of the electrodes $\frac{1}{2}$ – $\frac{1}{3}$ cm.; time, four hours. The current was N.D.₁₀₀=0.5–0.7 ampere and 2.8–3.3 volts at the ordinary temperature. The nickel found weighed 0.1233 gram. Apparatus suitable for the decomposition just described is represented in Fig. 32. The metal is deposited upon the weighed platinum cone in the beaker, C. The vessel is covered with a glass lid having suitable apertures for the positive and negative electrodes. As soon as the blue-colored liquid becomes colorless, an indication that the metal

is completely precipitated, remove a few drops and test with a solution of potassium sulphocarbonate. If the latter causes only a faint rose-red coloration the deposition of metal may be considered complete. If the electrolysis is unnecessarily prolonged, metallic sulphide may be produced (Lehrbuch der analyt. Chemie, Miller and Kiliani). It is not advisable to interrupt the current or to remove the cone from the electrolyzed liquid until the latter has been replaced by water. This is effected by the vessels to the left of the figure: *A* is an aspirator, filled with water; *B* is air-tight and empty; *x* is a doubly bent tube extending to the bottom of *C*. Open *p* and the liquid in *C* is gradually transferred to *B*. Add fresh water in *C*. Ammonium chloride should not be present in the solution undergoing electrolysis.

Vortmann adds tartaric or citric acid and an excess of sodium carbonate to the solution of the nickel salt, then electrolyzes with a current density of $N.D._{100} = 0.3-0.4$ ampere. The deposit may contain traces of carbon.

The statements upon nickel also apply to cobalt. An experiment, taken from the article of Fresenius and Bergmann, is here given as a guide in determining cobalt: 50 c.c. of cobalt sulphate (=0.1280 gram of cobalt), 100 c.c. of ammonia, 10 c.c. of ammonium sulphate, 100 c.c. of water; current $N.D._{100} = 0.5-0.7$ ampere and 2.8-3.3 volts at the ordinary temperature; separation of electrodes, $\frac{1}{2}-\frac{1}{3}$ cm. Time, five hours. The deposited cobalt weighed 0.1286 gram.

Use potassium sulphocarbonate to test when the metal is fully reduced; it gives a wine-yellow coloration with even the most dilute solutions of cobalt salts.

When too little ammonia is present in the electrolyte the results are bad; too much of this reagent retards the deposition of the cobalt.

v. Foregger adds 15 to 20 grams of ammonium carbonate to the solution of 1 gram of nickel sulphate, dilutes with water

to 150 c.c., heats to 60°, and electrolyzes with $N.D._{100} = 1-1.5$ amperes and 3.5-4 volts. Two hours will be required for the precipitation.

Oettel observed that, contrary to general statements, nickel could be as well precipitated from an ammoniacal chloride as from an ammoniacal sulphate solution. With a current of $N.D._{100} = 0.45$ ampere in the presence of 40 c.c. of free ammonia (sp. gr. 0.92), 10 grams of ammonium chloride and nickel chloride equivalent to 1.0456 grams of metal (total dilution 200 c.c.), he succeeded in throwing out 1.0462 grams of metal in six and one-quarter hours. Nitric acid should not be present. More difficulty was experienced with cobalt. The most favorable results were obtained with a current of $N.D._{100} = 0.4-0.5$ ampere. The quantity of ammonium chloride should be at least four times that of the cobalt and the solution should contain one-fifth of its volume of free ammonia (sp. gr. 0.92). When precipitating these metals from the solutions of their double oxalates, the conditions should be: 4 to 5 grams of ammonium oxalate, 120 c.c. total dilution, temperature 60°-70°, with $N.D._{100} = 1$ ampere and 4 volts.

The writer has electrolyzed cobalt compounds containing an excess of an alkaline acetate (*see Zinc*) with perfectly satisfactory results, and would recommend such solutions for this particular metal.

In this laboratory the following conditions are observed in precipitating nickel from a cyanide solution: Add 0.1 gram more of alkaline cyanide than is necessary for the precipitation and re-solution, 2 grams of ammonium carbonate, dilute to 150 c.c., heat to 60°, and electrolyze with $N.D._{100} = 1.5$ amperes and 6-6.5 volts. The nickel will be fully precipitated in three and one-half hours. Cobalt may be precipitated under similar conditions.

Sodium pyrophosphate precipitates a greenish-white pyro-

phosphate from nickel solutions, an excess of the reagent dissolves the precipitate, while the liquid becomes yellow-green in color. The latter is changed to green by ammonium carbonate, and to blue by ammonium hydroxide. When electrolyzing a nickel solution add to it 20 c.c. of a sodium pyrophosphate solution, 25 c.c. of ammonia (0.91 sp. gr.), and 150 c.c. of water. A current of 0.5 to 0.8 ampere will be sufficient to throw out the nickel in nine hours. This method will serve equally well for the estimation of cobalt.

In determining nickel, Campbell and Andrews dissolve nickel hydrate in 30 c.c. of a 10 per cent. solution of sodium phosphate, add 30 c.c. of ammonia to the same, dilute to 125 c.c. and electrolyze with $N.D._{100} = 0.14$ ampere, the electrodes being separated 5 mm. The precipitation is complete in twelve hours.

Thiel (*Z. f. Elektroch.*, 14, 201) calls attention to the fact that, contrary to the usual statement, nickel may be quantitatively precipitated from a solution containing ammonium nitrate. He attributes the observed disturbance to the presence of nitrites or nitrous acid. The latter he removes by boiling the solution, or by the addition of urea to the boiling liquid, or by oxidation with ammonium persulphate. A coin containing nickel and copper was dissolved in nitric acid and the solution evaporated almost to dryness, after which the copper was precipitated in the usual manner and then the liquid was neutralized with ammonium hydroxide and 30 c.c. of the same reagent of the specific gravity 0.91 were added. The solution was heated to 70° and electrolyzed with $N.D._{100} = 2$ amperes. The cathode was a platinum gauze. The nickel was always precipitated upon the copper. The conclusion of Thiel is that nickel may be quantitatively separated in ammoniacal nitrate solutions free from nitrous acid. Iron wire is preferred as an anode.

Schumann has further shown that when using nickel nitrate

solutions, if 30 to 40 c.c. of ammonium hydroxide be present, the quantitative deposition of the metal is assumed.

The Rapid Precipitation of Nickel With the Use of a Rotating Anode.

The results obtained by Exner in the precipitation of metals with the aid of a rotating anode have led to a most careful investigation of the best conditions for each metal. This study, with nickel, has developed most interesting data in the hands of West, *J. Am. Ch. S.*, **26**, 1596. The details are given under several electrolytes. The conditions there described, if adhered to, will lead to the most satisfactory results. The dilution of the various electrolytes ranged from 100 to 125 c.c., representing a cathode surface of 100 sq. cm., while the anode performed 500 to 600 revolutions per minute. From solutions containing an excess of ammonia the nickel deposits were crystalline and gray in color, while in acid solutions the metal was brilliant and very metallic in appearance—closely resembling the platinum. Sometimes peroxide appeared on the anode. It was made to disappear, in ammoniacal solutions, by adding more ammonium hydroxide to the electrolyte, and if it occurred in acid solutions by lowering the current toward the end of the decomposition, and after a few minutes again increasing it, or by introducing into the acid liquid a few drops of a mixture consisting of 5 c.c. of glycerol, 45 c.c. of alcohol and 50 c.c. of water.

In an *ammoniacal acetate electrolyte* the working conditions should be:

For 0.4444 gram of nickel, 25 c.c. of ammonium hydroxide (sp. gr. 0.94), 10 c.c. of acetic acid and 125 c.c. dilution, a current of $N.D._{100} = 5$ amperes and 4.6 volts. In twenty minutes the metal will be completely precipitated. In the presence of sodium acetate and free acetic acid the precipitation is slower. Thirty minutes were necessary for the precipitation

of the quantity of metal mentioned in the preceding paragraph.

In an electrolyte of *ammonium hydrate and ammonium sulphate*, which is the time-honored solution for the deposition of nickel, conditions like these will answer:

Electrolyze the salt solution (containing 1.0100 gram of metal), 1.2 gram of ammonium sulphate and 30 c.c. of ammonium hydroxide (sp. gr. 0.94) with a current of 5.2 amperes and 6.5 volts. The precipitation will be complete in twenty-five minutes.

The *rate of precipitation*, using a solution containing 0.5050 gram of metal, with a current of $N.D._{100} = 4$ amperes and 5.5 volts, was:

In 1 minute.....	0.0571 gram
In 2 minutes.....	0.1164 gram
In 3 minutes.....	0.1549 gram
In 4 minutes.....	0.2000 gram
In 5 minutes.....	0.2510 gram
In 7½ minutes.....	0.3580 gram
In 10 minutes.....	0.4450 gram
In 15 minutes.....	0.5007 gram
In 20 minutes.....	0.5050 gram

A *formate electrolyte* answers admirably for the precipitation of nickel.

To a solution containing 0.4444 gram of metal, add 20 c.c. of ammonium hydroxide (0.094 sp. gr.) and 10 c.c. of formic acid, then electrolyze with a current of $N.D._{100} = 5$ amperes and 4 volts. All of the metal will be precipitated in fifteen minutes.

Or, the metal may be completely precipitated with sodium carbonate and the precipitate be dissolved in an excess of formic acid. For example, to a solution of nickel sulphate (0.4444 gram of nickel) add five grams of sodium carbonate and 22 c.c. of formic acid (25 per cent.), then electrolyze with a current of $N.D._{100} = 5$ amperes and 4 volts. In 30 minutes the metal will be completely precipitated.

The *rate of precipitation* in this electrolyte was, with a current of 5 amperes and 4 volts, as follows:

In 5 minutes.....	0.2474 gram
In 7½ minutes.....	0.3260 gram
In 10 minutes.....	0.3688 gram
In 15 minutes.....	0.4323 gram
In 20 minutes.....	0.4394 gram
In 30 minutes.....	0.4448 gram

Nickel is quite easily determined in an *electrolyte of ammonium lactate*. Dilution and speed should be the same as in the preceding electrolytes.

Conduct a current of 5 amperes and 7.5 volts through the solution (containing 0.4444 gram of nickel), in which are present 25 c.c. of ammonium hydroxide (sp. gr. 0.94) and 2.5 c.c. of lactic acid. The precipitation will be complete in twenty minutes. The *rate of precipitation* is:

In 5 minutes.....	0.3151 gram
In 7½ minutes.....	0.4056 gram
In 10 minutes.....	0.4344 gram
In 15 minutes.....	0.4443 gram
In 20 minutes.....	0.4443 gram

The Rapid Precipitation of Nickel With the Use of the Rotating Anode and Mercury Cathode.

In the experiments given in the table on page 134 a solution of nickel sulphate, equivalent to 0.4802 gram of metal in ten cubic centimeters, was used.

The *rate of precipitation*, when using a current of 2 amperes and 7 volts, was found to be:

In 2½ minutes.....	0.2017 gram of metal
In 7½ minutes.....	0.4095 gram of metal
In 10 minutes.....	0.4651 gram of metal
In 12½ minutes.....	0.4774 gram of metal
In 15 minutes.....	0.4802 gram of metal

NICKEL.

EXP.	NICKEL PRESENT IN GRAMS.	SULPHURIC ACID IN C.C.	VOLUME IN C.C.	CURRENT. AMPERES.	VOLTS.	REVOLUTIONS OF ANODE PER MINUTE.	TIME IN MINUTES.	NICKEL FOUND IN GRAMS.	ERROR IN GRAMS.
1	0.4802	0.25	18	2	7	600	18	0.4802	—
2	0.4802	0.25	12	3.5	7	600	16	0.4799	-0.0003
3	0.4802	0.25	12	2-4	6.5	600	10	0.4806	+0.0004
4	0.4802	0.25	12	6	5	500	7	0.4804	+0.0002
5	0.4802	0.25	12	5	6.5	600	10	0.4796	-0.0006
6	0.9604	0.25	10-30	4	6	1,100	10	0.9597	-0.0007
7	0.4802	0.25	12	3	7-5	1,100	10	0.4806	+0.0004
8	0.4802	0.25	12	3	7	1,100	10	0.4796	-0.0006
9	0.9604	0.25	12	3.5	7	1,100	16	0.9604	—
10	0.4802	0.25	12	5	7	640	12	0.4809	+0.0007
11	0.4802	0.25	12	5	6	880	8	0.4806	+0.0004
12	0.4802	0.25	7	6	5	1,200	9	0.4801	-0.0001
13	0.4802	0.25	7	6	6	1,200	7	0.4801	-0.0001

Nickel amalgam is very bright in appearance. A gram of the metal combined with the usual quantity of mercury (40 grams) imparts to the amalgam the consistency of soft dough.

The Rapid Precipitation of Cobalt With the Use of a Rotating Anode.

Various electrolytes have been studied by Miss Kollock (J. Am. Ch. S., 26, 1606) to fix more definitely the conditions so successfully used by Exner. The results conclusively demonstrate that the introduction of the rotating anode has given the electrolytic method of estimating cobalt a very superior value. The details in procedure are analogous to those described under nickel.

To precipitate it from a *sodium formate electrolyte*, add to a cobalt sulphate solution (=0.3535 gram of metal) 2.5 grams of pure sodium carbonate and 4 c.c. (94 per cent.) formic acid. Heat the solution to boiling, remove the flame and electrolyze with a current of N.D.₁₀₀=5 amperes and 6 volts. The pre-

precipitation will be complete in thirty minutes. The deposit of cobalt is so brilliant that it is difficult to distinguish it from the platinum on which it is precipitated. In this electrolyte a slight anodic deposit may occur. The glycerol mixture, referred to under nickel, causes it to disappear or prevents its formation. However, it is preferable to lower the current to one ampere for a few minutes when the solution has nearly lost its color. Just as soon as the peroxide has disappeared from the anode restore the current to its original strength. Much formic acid retards the precipitation. If the liquid becomes alkaline the deposition is very rapid and the metal is spongy, hence add the acid drop by drop from time to time.

The *rate of precipitation* in a solution containing 0.3152 gram of cobalt was:

In 5 minutes.....	0.1470 gram of metal
In 7½ minutes.....	0.2096 gram of metal
In 10 minutes.....	0.2570 gram of metal
In 15 minutes.....	0.3066 gram of metal
In 20 minutes.....	0.3092 gram of metal
In 25 minutes.....	0.3142 gram of metal
In 30 minutes.....	0.3152 gram of metal

By applying a current of 6.5 amperes and 7 volts to a solution containing 0.3152 gram of cobalt in the presence of 20 c.c. of ammonium hydroxide and 3.5 c.c. of formic acid (94 per cent.) all of the metal will be precipitated in twenty minutes. If the solution is alkaline the metal deposit will be very compact in form and dull in appearance, while if the liquid is acid the cobalt will separate in a very brilliant form, but more slowly than from an ammoniacal solution. In this electrolyte—*formate*—there is little tendency to anodic deposition.

A very satisfactory electrolyte is that containing *ammonium acetate*.

Conduct a current of 5 amperes and 6 volts through a solu-

tion of cobalt sulphate (0.3310 gram of metal) containing 25 c.c. of ammonium hydroxide and 10 c.c. of 20 per cent. acetic acid. The metal will be fully deposited in twenty-five minutes. It will be brilliant in appearance and there will be no sign of anodic precipitation. A solution in which 0.2980 gram of metal was present gave the following *rate of precipitation*:

In 5 minutes.....	0.2235 gram of cobalt
In 10 minutes.....	0.2778 gram of cobalt
In 15 minutes.....	0.2950 gram of cobalt
In 20 minutes.....	0.2980 gram of cobalt
In 25 minutes.....	0.2980 gram of cobalt

An *electrolyte of lactic acid* or a *lactate* will also answer admirably in the estimation of this metal. Peroxide precipitation does not take place. The cobalt deposits are most adherent and exceedingly brilliant in appearance. A large excess of lactic acid retards the precipitation.

Add to the solution of cobalt sulphate (=0.3152 gram of metal), 2.2 grams of sodium carbonate and 5 c.c. of concentrated lactic acid, and with a current of $N.D._{100}=5$ amperes and 8 volts the precipitation will be complete in twenty-five minutes.

In an *ammonium lactate* solution the results are, if anything, superior to those in the preceding electrolyte. As a rule the solution becomes colorless in twenty-five minutes.

To a solution of the sulphate (=0.3310 gram of metal), add 30 c.c. of ammonium hydroxide and 7 c.c. of lactic acid and electrolyze with $N.D._{100}=6$ amperes and 5 volts. Twenty-five minutes will suffice for complete precipitation.

The *rate of precipitation* was found to be:

In 5 minutes.....	0.2215 gram of metal
In 10 minutes.....	0.3060 gram of metal
In 15 minutes.....	0.3230 gram of metal
In 20 minutes.....	0.3290 gram of metal
In 25 minutes.....	0.3310 gram of metal
In 30 minutes.....	0.3310 gram of metal

An *electrolyte of ammonium succinate* can be employed. Some carbon is apt to be precipitated with the cobalt. Sodium succinate should not be used.

The Rapid Precipitation of Cobalt With the Use of the Rotating Anode and Mercury Cathode.

Cobalt does not seem to enter the mercury with the same rapidity as the nickel under like conditions. The appended table presents a list of experiments. By duplicating any one of them satisfactory results may be expected. Cobalt sulphate was the salt used:

COBALT.

EXP.	COBALT PRESENT IN GRAMS.	SULPHURIC ACID PRESENT IN C.C.	VOLUME IN C.C.	CURRENT, AMPERES.	VOLTS.	REVOLUTIONS OF ANODE PER MINUTE.	TIME IN MINUTES.	COBALT FOUND IN GRAMS.	ERROR IN GRAMS.
1	0.3525	0.35	15	5	7	1250	15	0.3522	—0.0003
2	0.3525	0.25	15	3	5	980	18	0.3524	—0.0001
3	0.3525	0.25	15	4	6	600	14	0.3523	—0.0002
4	0.3525	0.25	10	4	6	860	16	0.3530	+0.0005
5	0.3525	0.5	10	4	6	1000	15	0.3530	+0.0005
6	0.3525	0.0	10	4	6	1240	16	0.3528	+0.0003
7	0.3525	0.25	10	3	6	1200	10	0.3521	—0.0004
8	0.3525	0.5	10	6	6	1200	10	0.3530	+0.0005
9	0.3525	0.25	10	5	8	800	10	0.3522	—0.0003
10	0.3525	0.25	10	3	8	1400	12	0.3523	—0.0002
11	0.3525	0.5	10	6	5	800	11	0.3530	+0.0005
12	0.7050	0.5	15	6	7	1200	30	0.7052	+0.0002
13	0.1762	0.35	10	4	8	560	7	0.1762	—

A solution of cobalt chloride may also be used (p. 93). Thus, introduce into the mercury cup 5 c.c. of a cobalt chloride solution (=0.1250 gram of metal), cover the same with 10 c.c. of pure toluene and electrolyze with a current of from 2 to 4 amperes and 5 volts. In five minutes the liquid will be colorless, and the metal will be completely precipitated in 7 minutes.

MANGANESE.

LITERATURE.—Z. f. a. Ch., **11**, 14; Richè, Ann. de Chim. et de Phys. [5th ser.], **13**, 508; Luckow, Z. f. a. Ch., **19**, 17; Schucht, Z. f. a. Ch., **22**, 493; Classen and v. Reiss, Ber., **14**, 1622; Moore, Ch. N., **53**, 209; Smith and Frankel, Jr. An. Ch., **3**, 385; Ch. N., **60**, 262; Brand, Z. f. a. Ch., **28**, 581; Rüdorff, Z. f. ang. Ch., Jahrg. **15**, p. 6; Classen, Ber., **27**, 2060; Engels, Z. f. Elektrochem., **2**, 413; **3**, 286; Groeger, Z. f. ang. Ch. (1895), 253; Kaepfel, Z. f. anorg. Ch., **16**, 268; Currie, Ch. N., **91**, 247; Köster, Z. f. Elektroch., **10**, 553; Scholl, J. Am. Chem. S., **25**, 1045; Köster, Z. f. Elektrochem. (1904), **10**, 553; Otin, Z. f. Elektroch., **15**, 386; Köster, Z. f. Elektroch., **17**, 57; Gooch and Beyer, Am. Jr. S., series 4, **27**, 59.

The electric current causes this metal, when in solution as chloride, nitrate, or sulphate, to separate as the dioxide upon the anode (*see* Lead). In a solution of nitric acid, the hydrogen set free reduces the acid to oxides of nitrogen and, finally, to ammonia. Under such conditions complications may arise, particularly if other metals are present in the solution. For this reason a solution of the sulphate, slightly acidulated with two to six drops of sulphuric acid, is preferable for electrolytic purposes. Neumann prefers the mineral acid solutions for these depositions, and gives the following as illustrative examples:

(a) To the solution containing 0.3 gram of manganese nitrate, add 2 c.c. of concentrated nitric acid, dilute to 150 c.c. with water, and electrolyze with $N.D._{100} = 0.3$ ampere and 3–3.5 volts for two hours. It is advisable to add the acid during the course of the electrolysis. When its quantity exceeds 3 per cent. the permanganic acid reaction shows itself.

(b) Add 0.5 c.c. of concentrated sulphuric acid to the solution of 0.3 gram of manganese sulphate, dilute to 150 c.c., heat to 60° – 70° , and act upon the solution for four hours with a current of 0.4–0.6 ampere and 4 volts.

As soon as the manganese has been fully precipitated as dioxide, the current is interrupted, the deposit washed with

water, and should any of the dioxide become detached, it must be caught upon a small filter, then dried, ignited, and weighed, together with the adherent dioxide, which is changed to protosesquioxide (Mn_3O_4) before weighing. Groeger has demonstrated by iodometric tests that the composition of the precipitate only approximates the formula— $MnO_2 \cdot H_2O$ —usually assigned it. Further, it is useless to try to obtain a definite compound by drying. The product is so extremely hygroscopic that ignition alone to the protosesquioxide will give definite and concordant results.

In the presence of large quantities of iron, this precipitation is unsatisfactory; therefore, first remove the iron with barium carbonate. Tartaric, oxalic, and lactic acids retard the formation of manganese dioxide. The same is true of phosphoric acid. Potassium sulphocyanide also prevents its formation, and if added to solutions in which dioxide is already precipitated, it causes the same to redissolve.

Classen maintains that strong mineral acids, such as nitric and sulphuric, retard the complete deposition of the manganese. He regards acetic acid as the most suitable of all the organic acids for use in this precipitation. The conditions given are: 25 c.c. of acetic acid of specific gravity 1.069; 75 c.c. of water; temperature, 50° – 68° ; $N.D._{100} = 0.3$ – 0.35 ampere; $V = 4.3$ – 4.9 ; time, 3 hours; roughened dish.

Engels dissolves the manganese salt in 50 c.c. of water, adds 10 grams of ammonium acetate and $1\frac{1}{2}$ –2 grams of chrome alum, then dilutes with water to 150 c.c., heats to 80° , and applies a current of $N.D._{100} = 0.6$ – 0.9 ampere and 3–4 volts. The deposit is washed with water and alcohol, then dried and ignited. The deposition was made in roughened dishes of platinum. Alcohol (5–10 c.c.) may be substituted for the chrome alum, but more time will then be required for the precipitation.

Kaepfel has given the precipitation of manganese thought-

ful consideration. He confirms the experience of Engels, and adds that acetone is a very desirable addition. This method of procedure consists in heating the electrolyte to 55° , adding 1.5 to 10 grams of acetone, and electrolyzing with a current of $N.D._{100} = 0.7-1.2$ amperes and 4-4.25 volts for a period of from two to five hours. The acetone is converted into acetic acid, and it is the transitional formation of the latter that the author regards as more beneficial in the deposition than if it be added directly to the electrolyte.

In this laboratory a formate electrolyte has been used with good results. Thus, to a manganous sulphate solution (= 0.1100 gram of metal) were added 5 c.c. of formic acid (specific gravity 1.06), 10 c.c. of a sodium formate solution (= 1 gram of the salt); the whole was diluted to 130 c.c. with water and electrolyzed with a current of $N.D._{100} = 1.4$ ampere and a pressure ranging from 12 volts at the beginning to 8.6 volts at the end. The precipitation was finished at the expiration of one and a half hours. The deposit of dioxide was very adherent.

Later it was observed that the deposition could be satisfactorily made in the presence of free formic acid alone. The pressure was at the start high, because of the low conductivity of the formic acid. It fell in the course of an hour. An example from many will give the conditions. To a solution containing 0.2068 gram of manganese there were added 5 c.c. of formic acid (sp. gr. 1.09) and it was electrolyzed at room temperature with $N.D._{100} = 0.8$ to 1 ampere and 6.8 volts. The time required was five hours. The manganese weighed 0.2069 gram. The deposit from a formate electrolyte is very adherent. Formic acid is superior to acetic acid as an electrolyte. For the separation of manganese from iron and from zinc see pp. 262, 267.

The apparatus devised by Herpin (Fig. 33) can be well applied in the decomposition of manganese salts. It consists

of a platinum dish, *A*, resting upon a tripod, *B*, in connection with the cathode of a battery. The upper portion of the dish is so constructed that it will support an inverted glass funnel, *D*. Any loss from the bursting of bubbles is prevented by this means. The anode is a platinum spiral *C*. In estimating

FIG. 33.

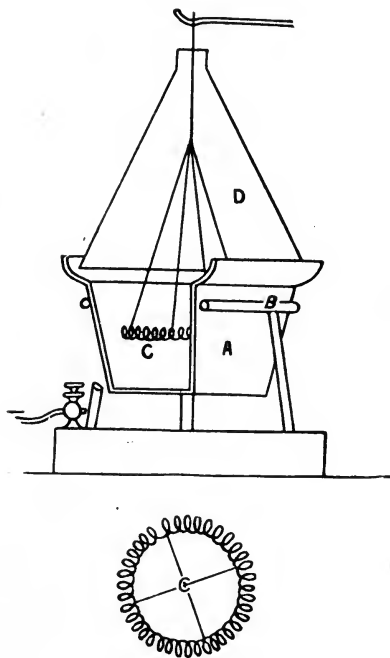

manganese it must not be forgotten to connect the dish with the anode of the battery employed for the decomposition.

The Rapid Precipitation of Manganese With the Use of a Rotating Electrode.

The experiments made in this direction, in this laboratory, were not successful. Köster has proposed the following:

To the electrolyte, about 130 c.c. in volume, containing the manganese salt (not the chloride) add 5 to 10 grams of ammonium acetate, 2 to 3 grams of chrome alum and several cubic centimeters of alcohol. Heat the solution to 75° C., remove the flame and electrolyze with $N.D._{100}=4$ to 4.5 amperes and a pressure of 7 volts. The same chemist suggests adding to the solution of the manganese salt 10 grams of ammonium acetate and about 10 cubic centimeters of 96 per cent. alcohol. The current density and pressure to be used are dependent upon the quantity of manganese present. For example, in the case of 0.2 gram of manganese or less, use a current of $N.D._{100}=4$ to 4.5 amperes and 7 to 8 volts; when there is a larger quantity use but 2 amperes and 4 to 5 volts. The author declares that in the presence of more than 0.3 gram of manganese neither suggestion, as given above, can be relied upon, because oxide will detach itself even from a sand-blasted electrode. The time required for precipitation varies from 20 to 25 minutes.

IRON.

LITERATURE.—Wrightson, Z. f. a. Ch., 15, 305; Parodi and Mascazzini, G. ch. ital., 8, 178; also Z. f. a. Ch., 18, 588; Luckow, Z. f. a. Ch., 19, 18; Classen and v. Reiss, Ber., 14, 1622; Classen, Z. f. Elektrochem., 1, 288; Moore, Ch. N., 53, 209; Smith, Am. Ch. Jr., 10, 330; Brand, Z. f. a. Ch., 28, 581; Drown and McKenna, Jr. An. Ch., 5, 627; Smith and Muhr, Jr. An. Ch., 5, 488; Rüdorff, Z. f. ang. Ch., 15, 198; Vortmann, M. f. Ch., 14, 536; Heidenreich, Ber., 29, 1585; Avery and Dales, Ber., 32, 64, 2233; Verwer and Groll, Ber., 32, 37, 806; Goecke, Dissertation, Bonn, 1900; Kollock, J. Am. Ch. S., 21, 928; Exner, J. Am. Ch. S., 25, 903; Kollock and Smith, Am. Phil. Soc. Pr., 44, 149; *ibid.*, 45, 261.

The suggestion of Parodi and Mascazzini relative to the precipitation of iron (p. 27) has since been elaborated by Classen, and by him applied to many other metals. Following the recommendation of this chemist, about six to seven

grams of ammonium oxalate are dissolved in as little water as possible, and the iron salt solution gradually added to it with constant stirring. The liquid is then diluted with water to 150–175 c.c., and electrolyzed at the ordinary temperature with a current of $N.D._{100} = 1.5$ amperes and 2–4.5 volts, or at the temperature of 40° – 65° with 0.5–1.0 ampere and 2–3.5 volts. If ferric hydroxide should separate during the electrolytic decomposition, it can be redissolved by adding oxalic acid drop by drop. Test the clear liquid, acidulated with hydrochloric acid, with potassium sulphocyanide. The deposited iron has a steel-gray color; it should be washed with water, alcohol, and ether. Avoid the presence of chlorides and nitrates. By carefully complying with the conditions recommended by Classen good results are sure to follow. To show that persons with but little experience do succeed with the preceding method the two following determinations, made by a student, are given: A quantity of ferric ammonium sulphate (=0.0814 gram of iron) was dissolved in 200 c.c. of water, and to this were added 8 grams of ammonium oxalate. The solution was heated to 80° , and in two hours, with a current of 1.5 amperes, 0.0814 gram of iron was obtained. In a second experiment the quantity of iron was doubled (=0.1628 gram of iron), while the ammonium oxalate was 11 grams, temperature 66° , and the current 1 ampere. The precipitated iron weighed 0.1619 gram instead of 0.1628.

The writer found the following procedure admirably suited for iron determinations: 10 c.c. iron solution (= 0.1277 gram of metal), 10 c.c. sodium citrate (1.8 grams) with 3 c.c. of citric acid (0.059 gram), then diluted with water to 250 c.c., and electrolyzed with a current of $N.D._{100} = 0.8$ ampere and 7–8 volts at 50° for four and one-half hours. The iron deposit weighed 0.1280 gram. It contained 0.94 per cent. of carbon. The deposit was washed as already directed. In several determinations aluminium and titanium were present with the

iron, but the latter was precipitated free from the other two. For this reason the writer regards the method as useful. E. F. Kern, working in this laboratory with the view of arriving at some knowledge in regard to the carbon deposition, after long and painstaking experimentation, recommends the following conditions as favorable for the getting of iron deposits free from the carbon impurity: Add 1 gram of sodium citrate and 0.1 gram of citric acid to the solution of iron sulphate (0.1 gram of metal), dilute to 150 c.c., heat to 60°, and electrolyze with $N.D._{100} = 0.8-1.3$ amperes and 9 volts. Just as soon as the iron is precipitated, siphon off the liquid and wash without interruption of the current. The opinion exists that prolonged action of the current after the metal is all deposited tends to increase the carbon content of the iron.

From ammoniacal tartrate solutions iron is also precipitated, but carries carbon with it. It would therefore not be advisable to use this electrolyte except in cases where separations were desired, which were possible only in solutions of this character.

A third method, originated by Moore, advises that glacial phosphoric acid (15 per cent. acid) be added to the distinctly acid solution of ferric chloride or sulphate, until the yellow color fully disappears; then a large excess of ammonium carbonate is added and a gentle heat is applied until the liquid becomes clear. On electrolyzing the hot (70°) solution with a current of 2 amperes, the iron is rapidly and completely deposited at the rate of 0.75 gram per hour. Avery and Dales, on the other hand, claim that with a current of $N.D._{100} = 2$ amperes and 5 volts they were not able to precipitate more than 0.2 gram of iron in five hours. The end of the decomposition is recognized by testing a portion of the solution with ammonium sulphide. Wash the deposit as already directed.

Quite a little discussion has been had upon the deposition of iron and its enclosures. Avery and Dales ques-

tion whether the metal is fully precipitated from any one of the electrolytes described in the preceding paragraphs; furthermore, they affirm that even from an oxalate solution the iron carries down carbon with it; that oxalic acid is converted in part, at least, into glycollic acid, and that iron salts in the presence of the latter acid yield upon electrolysis a metal strongly contaminated with hydrocarbons. As to Moore's method, they assert that phosphorus is always present in the deposit of iron. Goecke concurs with these chemists in their views on the cathodic contaminations. Verwer and Groll think that iron, from an oxalate solution, is absolutely free from carbon, while Classen attributes the trifling amounts of carbon, which have been observed, to carelessness and inexperience in the execution of the prescribed directions.

Consult Blum and Smith, *Am. Phil. Soc. Pr.*, 46, 59, on the cathodic precipitation of carbon.

Drown, pursuing a suggestion made by Wolcott Gibbs in 1883 relative to the precipitation of metals in the form of amalgams, has applied it to the determination of iron. The trial tests were made with a solution of ferrous ammonium sulphate, slightly acidulated with sulphuric acid, to which a large excess of mercury was added (not less than fifty times the weight of the iron to be precipitated). A large platinum anode was used, while the mercury cathode was brought into the circuit by means of a platinum wire enclosed and fused into one end of a glass tube which passed through the liquid. The current employed for the precipitation equaled about 2 amperes per minute. The author remarks that if these conditions be observed, as much as 10 grams of iron can be precipitated in from ten to fifteen hours.

The decomposition was carried out in beakers. Care should be exercised in drying, so that no mercury is volatilized.

The Rapid Precipitation of Iron With the Use of a Rotating Anode.

1. To a solution of ferric ammonium sulphate (0.2461 gram of iron) were added 7.5 grams of ammonium oxalate and one cubic centimeter of a saturated solution of oxalic acid. This was then electrolyzed after heating to boiling with a current of $N.D._{100} = 7$ amperes and 7.5 volts. In twenty-five minutes 0.2461 gram of iron was precipitated. The deposit of metal was very dense and so light in color that it resembled the polished platinum dish on which it was precipitated.

2. In this trial all the conditions were like those in 1, excepting the quantity of iron equaled 0.4922 gram. In thirty-five minutes this exact amount of metal was obtained. In this laboratory, very successful determinations of iron have been made from an ammoniacal lactate electrolyte. The iron present should not exceed 0.1 gm. Observe the following conditions: To the solution, of iron salt (ferric ammonium alum, etc.) add 10 c.c. of lactic acid (U. S. P.). Stir till a thoroughly homogeneous solution results, then add 15 c.c. of ammonia (Sp. G. 0.91), dilute to 125 c.c. and electrolyze with the use of a rotating anode and platinum cathode at $N. D._{100} = 2$ to 3 amperes with 5 volts. The iron is deposited in a smooth, brilliant, gray form and contains no appreciable amounts of cathodic carbon.

The Rapid Precipitation of Iron With the Use of the Rotating Anode and Mercury Cathode.

In carrying out this precipitation an example will give the most satisfactory information:

Five cubic centimeters contained 0.2075 gram of iron. Three drops (40 drops = 1 cubic centimeter) of concentrated sulphuric acid were added to it, when it was electrolyzed with a current of 3 to 4 amperes and 7 volts. The anode made

from 500 to 900 revolutions per minute. The iron was completely deposited in seven minutes. The water was then siphoned off and the amalgam washed as in all previous cases with alcohol and water.

The *rate of precipitation*, under the conditions just mentioned, was:

In 2 minutes. 0.1760 gram of iron was deposited
 In 4 minutes. 0.2000 gram of iron was deposited
 In 6 minutes. 0.2050 gram of iron was deposited
 In 8 minutes. 0.2075 gram of iron was deposited

The following table exhibits conditions which can be relied upon:

	IRON PRESENT IN GRAMS.	SULPHURIC ACID IN DROPS [40 DROPS = 1 C.C.]	VOLUME IN C.C.	CURRENT. AMPERES.	VOLTS.	REVOLUTIONS OF ANODE PER MINUTE.	TIME IN MINUTES.	IRON FOUND IN GRAMS.	ERROR IN GRAMS.
1	0.2075	7	5	4-5	8.7	520	14	0.2072	-0.0003
2	0.2075	4	5-15	5-4	6.5-5	680	14	0.2078	+0.0003
3	0.2075	5	5-10	3.2-4	6.5	680	15	0.2077	-0.0003
4	0.2075	3	5	2-2.5	7-6	680	15	0.2073	-0.0002
5	0.2075	3	5	4	6-5	680	10	0.2080	+0.0005
6	0.2075	3	5	3-4.5	7-6	920	7	0.2078	+0.0003
7	0.2075	3	5	2-3	6	740	9	0.2076	+0.0001
8	0.2075	3	5	2-4	6.5-5.5	700	9	0.2076	+0.0001

When the metal exists as chloride this salt may be electrolyzed with ease, taking the precaution to add to the electrolyte a layer of pure toluene (p. 93). For example, to 5 cubic centimeters of a pure ferric chloride solution (=0.1030 gram of iron) were added 10 cubic centimeters of toluene and the liquid electrolyzed with a current of 2 to 4 amperes and 9 volts. In twelve minutes the total quantity of metal had entered the mercury.

CHROMIUM.

LITERATURE.—Myers, J. Am. Chem. S., 26, 1128; Kollöck and Smith, Am. Phil. Soc. Pr., 44, 146.

This metal has never, until recently, been determined in the electrolytic way. Upon experimenting with a solution of its sulphate it was found that chromium would enter or attach itself to a mercury cathode; accordingly a solution of this salt was electrolyzed in the mercury cup (p. 63), using stationary electrodes. Ten cubic centimeters of the salt solution contained 0.1080 gram of chromium. The working conditions are shown in the following table:

	CHROMIUM PRESENT IN GRAMS.	CHROMIUM FOUND IN GRAMS.	SULPHURIC ACID (Sp. G. 1.832) PRESENT IN DROPS.	TIME. HOURS.	CONDITIONS.			
					AMPERES.	VOLTS.	AMPERES.	VOLTS.
1	0.1080	0.1079	2	3	0.3	7	0.55	5.5
2	0.1080	0.1080	3	14	0.3	7	0.55	5.5
3	0.2160	0.2157	4	14	0.4	7.5	0.7	6
4	0.2160	0.2160	4	14	0.4	7.5	0.7	6
5	0.3240	0.3235	8	30	0.7	7	2.0	6.5
6	0.3240	0.3222*	6	30	0.65	7	2.5	8

The initial voltage and amperage are given to the left in the table. The acid liberated, during the course of the electrolysis, causes the potential to fall and the current to rise to the final voltage and amperage exhibited on the right. Chromium amalgam is not very stable. Water rapidly decomposes it with the separation of metallic chromium as a fine black powder on the surface of the mercury. The amalgam must, therefore, be washed as rapidly as possible. A given amount of mercury should not be used for more than one

* Some chromium floated off in wash water.

decomposition. The appearance of an oxide of chromium in the electrolyte indicates an insufficient amount of acid.

The Rapid Precipitation of Chromium With the Use of the Rotating Anode and Mercury Cathode.

To 10 cubic centimeters of chromium sulphate (=0.1180 gram of metal) add three drops of concentrated sulphuric acid (40 drops=1 cubic centimeter), and electrolyze with a current of from 4 to 5 amperes and 6 volts, the speed of the anode being 400 revolutions per minute. Six minutes will more than suffice for the complete precipitation of the metal. Siphon off the acid liquid, and wash the amalgam as quickly as possible with anhydrous alcohol and ether.

The following table shows conditions which may be relied upon to yield results that will be satisfactory in every way:

EXPERIMENT.	CHROMIUM PRESENT IN GRAMS.	SULPHURIC ACID [40 DROPS=1 C.C.]	VOLUME IN C.C.	CURRENT. AMPERES.	VOLTS.	REVOLUTIONS OF ANODE PER MINUTE.	TIME IN MINUTES.	CHROMIUM FOUND IN GRAMS.	ERROR IN GRAMS.
1	0.1180	5	10-15	3-4	7	280	15	0.1186	+0.0006
2	0.1180	3	10-15	2-4	11-9	280	15	0.1187	+0.0007
3	0.1180	3	10-15	1-3	9	640	20	0.1185	+0.0005
4	0.1180	3	8-15	1.5-3	10-8	220	15	0.1186	+0.0006
5	0.1180	3	10-15	1-3	11-9	520	20	0.1186	+0.0006
6	0.1180	3	5-15	1-2	11-9	640	17	0.1175	-0.0005
7	0.1180	3	5-15	2-4	9-8	480	15	0.1180	—
8	0.2360	3	5-15	2.5	10	520	50	0.2355	-0.0005
9	0.1180	5	5-15	3	7.5	400	15	0.1179	-0.0001
10	0.1180	3	7-15	4-5	8	640	6	0.1175	-0.0005
11	0.1180	3	7-15	3-4	10-9	640	10	0.1180	—
12	0.1180	7	7-15	3-4	10-8	200	13	0.1187	+0.0007
13	0.1180	3	5-15	3.5	8	640	11	0.1177	-0.0003
14	0.2360	4	5-15	3	12	640	35	0.2359	-0.0001
15	0.1180	3	5-15	3-4	10-8	320	11	0.1179	-0.0001
16	0.1180	3	5-15	3-4	10	540	11	0.1182	+0.0002

The *rate of precipitation* would be:

In 2 minutes.....	0.0480 gram of metal
In 4 minutes.....	0.0850 gram of metal
In 6 minutes.....	0.1000 gram of metal
In 8 minutes.....	0.1105 gram of metal
In 9 minutes.....	0.1185 gram of metal
In 10 minutes.....	0.1185 gram of metal

URANIUM.

LITERATURE.—L u c k o w, Z. f. a. Ch., **19**, 18; S m i t h, Am. Ch. Jr., **1**, 329; S m i t h and W a l l a c e, J. Am. Ch. S., **20**, 279; K o l l o c k and S m i t h, J. Am. Ch. S., **23**, 607; K e r n, J. Am. Ch. S., **23**, 685; W h e r r y and S m i t h, J. Am. Ch. S., **29**, 806.

For electrolytic purposes use the acetate, the sulphate, or the nitrate. Connect the dish in which the deposition is made with the negative electrode of the battery. The uranium separates as yellow uranic hydroxide upon the cathode; by the continued action of the current it changes to the black hydrated protosesquioxide. As soon as the solution becomes colorless, interrupt the current, wash with a little acetic acid and boiling water; dry, ignite, and weigh as protosesquioxide. If any of the hydrate becomes detached, collect the same upon a small filter, and ignite the latter together with the dish contents. Conditions leading to successful results are contained in the following examples:

ELECTROLYSIS OF URANIUM ACETATE.

U ₃ O ₈ PRESENT, IN GRAMS.	29 PER CENT. ACETIC ACID. C.C.	DILUTION C.C.	CURRENT.	VOLTS.	TEMPERATURE. °C.	TIME. HOURS.	U ₃ O ₈ FOUND IN GRAMS.	ERROR IN GRAMS.
0.0986	0.2	125	N.D. _{.107} = 0.29A	16.25	70	5	0.0988	+0.0002
0.0986	0.2	125	N.D. _{.107} = 0.3 A	12.2	70	5	0.0989	+0.0003
0.1972	0.2	125	N.D. _{.107} = 0.3 A	10.75	70	6	0.1970	-0.0002
0.2298	0.1	125	N.D. _{.107} = 0.09A	4.25	70	6	0.2297	-0.0001
0.2298	0.2	125	N.D. _{.107} = 0.07A	4.25	70	5½	0.2299	+0.0001

ELECTROLYSIS OF URANYL NITRATE SOLUTIONS.

U ₃ O ₈ PRESENT, IN GRAMS.	DILUTION C.C.	TEMPERA- TURE °C.	CURRENT.	VOLTS.	TIME. HOURS.	U ₃ O ₈ FOUND IN GRAMS.
0.1222	125	75	N.D. _{.107} = 0.035A	4.6	5½	0.1225
0.1222	125	65	N.D. _{.107} = 0.04 A	2.25	7¾	0.1218

Quantitative results were also obtained by the electrolysis of the sulphate. The neutral salt solution was diluted to 125 c.c. and heated to 75° C., when a current of from 0.02 to 0.04 ampere for 107 sq. cm. of cathode surface and 2.25 volts was conducted through the liquid.

ELECTROLYSIS OF URANYL SULPHATE.

U ₃ O ₈ PRESENT, IN GRAMS.	DILUTION C.C.	TEMPERATURE. °C.	CURRENT.	VOLTS.	TIME. HOURS.	U ₃ O ₈ FOUND IN GRAMS.	ERROR IN GRAMS.
0.1320	125	75	N.D. _{.107} = 0.02 A	2	6¼	0.1320	—
0.1320	125	75	N.D. _{.107} = 0.02 A	2	5½	0.1322	+0.0002
0.1393	125	75	N.D. _{.107} = 0.04 A	2.25	5	0.1395	+0.0002
0.1393	125	70	N.D. _{.107} = 0.038A	2.25	7	0.1392	-0.0001

This method affords an excellent separation of uranium from the alkali and alkaline earth metals (p. 270).

The Rapid Precipitation of Uranium With the Use of a Rotating Anode (performing 600 revolutions per minute) may be seen in the results given in the table above, obtained when using a uranyl sulphate solution.

Either of the two electrolytes mentioned here will prove quite satisfactory, and the procedure cannot fail to commend itself to mineral analysts.

No.	U ₃ O ₈ PRESENT, IN GRAMS.	ACETIC ACID C.C.	SODIUM ACETATE IN GRAMS.	CURRENT IN AMPERES.	VOLTS.	TIME IN MINUTES.	TEMP.	U ₃ O ₈ FOUND IN GRAMS.
1	0.1527	0.2	2½	3	14	18	ord.	0.1513
2	0.1527	0.2	4¼	3	12	15	"	0.1525
3	0.2613	0.25	5½	7	15	8	60°	0.2611
4	0.2613	0.25	4½	4	12	3	50	0.0344
5	0.2613	0.25	4½	4	12	15	50	0.0530
6	0.2613	0.25	4½	4	12	10	50	0.1074
7	0.2613	0.25	4½	4	12	18	50	0.1935
8	0.2613	0.25	4½	4	12	25	50	0.2467
9	0.2613	0.25	4½	4	12	30	50	0.2611
			AM. CARBONATE IN GRAMS.					
10	0.2613		1	5	15	25		0.2600
11	0.2613		2	5	13	30		0.2613

THALLIUM.

LITERATURE.—Schucht, Z. f. a. Ch., **22**, 241, 490; Neumann, Ber., **21**, 356; Heiberg, Z. f. anorg. Ch., **35**, 346; Gallo and Cenni, Gazz. Chim. Ital. (1909), **39**, 285-296; Morden, J. Am. Ch. S., **31**, 1045.

This metal separates as sesquioxide, from acid solutions, upon the anode, while from ammoniacal liquids it is deposited partly as metal and partly as oxide. From oxalate solutions and from its double cyanides it separates only as metal when the current is feeble. However, difficulty is experienced in drying the deposit without having it oxidized. In this respect it is even more troublesome than lead. Neumann utilizes the current to separate the metal, dissolves the latter in acid, and measures the liberated hydrogen; from its

volume he calculates the quantity of thallium originally present. For suitable apparatus to carry out this method consult the literature cited above.

The recommendation of Heiberg is that to a solution of thallium sulphate (0.2 to 1.0 gram of salt) in 100 c.c. of water there be added 2 to 6 c.c. of normal sulphuric acid and 5 to 10 c.c. of acetone. Use a roughened dish which is made the anode during the decomposition. Heat to 55° C., and electrolyze with a current ranging from 0.02 to 0.05 ampere and pole pressure of 1.7 to 2.3 volts.

The precipitation is finished when 0.5 c.c. of the electrolyte produces no opalescence on bringing it into 3 to 5 c.c. of a five per cent. solution of potassium iodide. Pour out the liquid quickly from the dish and wash the deposit of oxide several times with water, alcohol, and ether. Dry for twenty minutes at 160°-165° in an air bath. Cool in a desiccator. The time for precipitation is about seven hours. The oxide is Tl_2O_3 .

G. W. Morden, working in this laboratory, found that the most satisfactory course to pursue in estimating thallium electrolytically consists in precipitating it with the aid of the *rotating anode and mercury cathode*. If the metal is precipitated directly into the mercury the resulting amalgam will on washing give up a portion of its thallium content to the water. This, however, may be absolutely prevented by precipitating a little zinc simultaneously in the mercury. Indeed, as small a quantity as 0.0007 gram of zinc will prevent any oxidation of as much as 0.1305 gram of thallium. To the solution of the sulphates contained in the mercury cup add a few drops of sulphuric acid (specific gravity 1.8) and electrolyze with a current of 5 amperes and 11 volts. In 10 minutes as much as 0.2250 gram of thallium may be precipitated and the amalgam washed and dried in the customary way.

INDIUM.

LITERATURE.—Thiel, *Z. f. anorg. Chemie*, **39**, 119; Dennis and Geer, *Ber.*, **37**, 175; *J. Am. Ch. S.* (1904), **26**, 438; Kollock and Smith, *J. Am. Ch. S.*, **32**, 1248.

Thiel asserts that indium may be determined in the electrolytic way with great accuracy. He recommends that it be deposited on a silver-plated platinum cathode.

Dennis and Geer found that this metal may be readily precipitated from solutions of its chloride or nitrate in the presence of pyridine, hydroxylamine or formic acid. The depositions from oxalic or oxalate solutions were not very satisfactory. The metal separated from an acetate electrolyte in a dark, spongy form, while from solutions containing pyridine it was brilliant white in color and very compact.

Frazer (*J. Am. Ch. S.*, **32**, 1248) found potassium cyanide a very satisfactory electrolyte, but observes that in the presence of 2 grams of sodium acetate, 0.2 c.c. of normal acetic acid and several drops of gelatin, a current of 5 amperes and 4 volts deposited the indium in a beautiful, adherent form in 40 minutes, if the temperature of the electrolyte was maintained at 60° C. The most satisfactory deposits of the metal were obtained in using an electrolyte containing from 0.75 gram to 1.5 grams of Rochelle salt. They were brilliant in appearance and perfectly adherent.

In making a determination dissolve the yellow oxide in one-sixth normal sulphuric acid, avoiding an excess. Add to this solution 25 cubic centimeters of formic acid (specific gravity 1.20) and 5 cubic centimeters of ammonia (specific gravity 0.908); then dilute to 200 cubic centimeters, and electrolyze with a current of $N.D._{100} = 9$ to 12 amperes. The quantity of metal varied from 0.2 to 1.5 grams. It was deposited on a rotating cathode—a roughened dish. The cathode will not be attacked so long as the electrolyte contains formic acid.

An indium sulphate solution containing a small amount of pure sulphuric acid was introduced into a mercury cup (p. 63) and electrolyzed with a current of from 2 to 4 amperes and a pressure of 7.5 to 6.5 volts. The anode made 750 revolutions per minute. The results were most satisfactory (J. Am. Ch. S., 32, 1248).

PLATINUM.

LITERATURE.—L u c k o w, Z. f. a. Ch., 19, 13; C l a s s e n, Ber., 17, 2467; S m i t h, Am. Ch. Jr., 13, 206; R ü d o r f f, Z. f. ang. Ch., 1892, 696; L a n g n e s s, J. Am. Ch. S., 29, 466.

The solutions of platinum salts, slightly acidulated with sulphuric acid, and acted upon by a feeble current, give up the metal as a bright, dense deposit upon the dish, frequently so light as to be scarcely distinguishable from the latter. In using platinum vessels for this purpose, first coat them with a rather thick layer of copper, upon which afterward deposit the metal. Wash the deposit with water and alcohol.

In ordinary gravimetric analysis, potassium is frequently estimated as potassio-platinum chloride, K_2PtCl_6 . This operation requires time and care. Rather dissolve the double salt in water, slightly acidulate the solution with sulphuric acid (2 to 3 per cent. by volume), and electrolyze with a current of $N.D._{100} = 0.1-0.2$ ampere. The deposit will be spongy. On heating to $60^\circ-65^\circ$ and electrolyzing with $N.D._{100} = 0.05$ ampere and 1.2 volts, the platinum will be completely precipitated in from four to five hours in a perfectly adherent form. It is often so dense as to be distinguished from hammered platinum with difficulty.

In the Munich laboratory the platinum salt solution is mixed with 2 per cent. (by volume) of a dilute sulphuric acid (1 : 5), heated to 70° , and electrolyzed with $N.D._{100} = 0.01-0.03$ ampere. The precipitation will be complete in five hours.

The following experiment executed in this laboratory demon-

strates that the precipitation of platinum from solutions containing sodium phosphate and free phosphoric acid is complete. The volume of the liquid was 150 c.c. It contained 0.1144 gram of metallic platinum, 30 c.c. of disodium hydrogen phosphate (sp. gr. 1.0358), and 5 c.c. of phosphoric acid (sp. gr. 1.347). The current equaled 0.8 ampere. The deposit of platinum weighed 0.1140 gram. It was precipitated upon a copper-coated platinum dish. It was washed with water and alcohol. Ten hours were required for the deposition.

The Rapid Precipitation of Platinum With the Use of the Rotating Anode.

In making the trials to obtain a rapid precipitation of metal a solution of potassium platinum chloride was used. Twenty-five cubic centimeters of this solution contained 0.0953 gram of platinum. The metal was deposited on a silver coated dish. The rotating *dish* anode (p. 78) was used in this electrolysis.

No.	H ₂ SO ₄ (DIL. 1:10) IN C.C.	VOLTS.	AMPERES.	TIME, MIN.	WT. OF PT. IN GRAMS.
1	5	5	10	7	0.0953
2	2.5	10	16	3	0.0952

On doubling the volume of the solution the following results were obtained:

No.	H ₂ SO ₄ (DIL. 1:10) IN C.C.	VOLTS.	AMPERES.	TIME, MIN.	WT. OF PT. IN GRAMS.
1	2.5	10	17	1	0.1158
2	2.5	10	18	2	0.1734
3	2.5	10	16	3	0.1855
4	2.5	10	18	4	0.1903
5	2.5	10	17	5	0.1904

The *rate of precipitation* is very evident from these figures.

PALLADIUM.

LITERATURE.—Wöhler, *Ann.*, **143**, 375; Schucht, *Z. f. a. Ch.*, **22**, 242; Smith and Keller, *Am. Ch. Jr.*, **12**, 252; Smith, *Am. Ch. Jr.*, **13**, 206; **14**, 435; Joly and Leidié, *C. r.*, **116**, 146; *Z. f. anorg. Ch.*, **3**, 476; Amberg, *Z. f. Elektrochem.* (1904), **10**, 386; *Annalen*, **341**, 271; Langness, *J. Am. Chem. S.*, **29**, 467.

Palladium can be deposited from solutions of the same kind and in the same manner as platinum. A bright metallic deposit will be obtained by the use of a current of N.D.₁₀₀ = 0.05 ampere and 1.2 volts; otherwise it is spongy.

It has been discovered, in this laboratory, that this metal can be rapidly and fully precipitated from ammoniacal solutions of palladammonium chloride, Pd(NH₃Cl)₂, which may be prepared by adding hydrochloric acid to an ammonium hydroxide solution of palladious chloride. To show the accuracy of this method, several actual determinations are here introduced: (1) A quantity of the double salt (=0.2228 gram of palladium) was dissolved in ammonium hydroxide; to this solution were added 20–30 c.c. of the same reagent (sp. gr. 0.935) and 100 c.c. of water. A current of 0.07–0.1 ampere acted upon this mixture through the night, and deposited 0.2225 gram of palladium. (2) In another experiment, with conditions similar to those just mentioned, excepting that the quantity of the palladammonium chloride was doubled, and the current held at 0.7 ampere, the quantity of metal precipitated equaled 0.4462 gram instead of 0.4456. Oxide did not separate upon the anode. The deposit, when dry, showed the same appearance as is ordinarily observed with this metal in sheet form. It was washed with hot water (70°), and dried in an air-bath at 110°–115°. It is best to deposit the palladium in platinum dishes previously coated with silver.

The Rapid Precipitation of Palladium With the Use of a Rotating Anode.

Amberg mentions having electrolyzed palladosammine chloride in sulphuric acid solution with a current of 0.3 ampere and 1.25 volts, when he succeeded in precipitating one gram of palladium upon a roughened dish in three hours. The anode performed from 600 to 650 revolutions per minute. The electrolyte was heated to 65°. The deposit of metal was perfectly adherent and resembled platinum. This chemist abandoned the silver or gold-coated platinum cathode, preferring to deposit the palladium directly upon the platinum, from which he later dissolved it by means of a saturated potassium chloride solution (70°–80°) to which were added crystals of chromic acid. This freshly prepared solution was poured over the palladium and the dish rocked constantly so that the platinum was only superficially attacked—if affected at all.

In this laboratory perfectly analogous results were obtained by electrolyzing an ammoniacal solution of palladammonium chloride. The anode was the *dish* (p. 78) used to such advantage in many other instances. Portions of such a solution (10 cubic centimeters contained 0.2680 gram of metal) were mixed with 20 cubic centimeters of boiling ammonium hydroxide, diluted with water to 60 cubic centimeters and electrolyzed.

RESULTS.

NO.	VOLTS.	AMPERES.	TIME, MIN.	WT. OF PD. IN GRAMS.
1	5-6	2+	18	0.2682
2	11	5	10	0.2680
3	17	7	5	0.2682
4	17	10	3	0.2678
5	17	10	2	0.2678
6	17	10	2	0.2683
7	17	10	2	0.2680
8	17	10	2	0.2681

The deposits were gray in color and perfectly adherent. In the last three the palladium was deposited directly on the platinum dish. It was later removed by the mixture to which reference has been made.

In a second series the quantity of metal present equaled in each instance 0.5360 gram.

RESULTS.

No.	NH ₄ OH IN C.C.	DILUTION.	VOLTS.	AMPERES.	TIME, MIN.	WT. OF P. IN GRAMS.
1	20	60 C.C.	15	14	3	0.5358
2	20	60 C.C.	17	14-20	2	0.5357
3	20	60 C.C.	17	14-20	1	0.4966

The deposits were almost like platinum in appearance. This procedure is particularly satisfactory with palladium; the time element is almost annihilated.

RHODIUM.

LITERATURE.—Smith, Jr. *An. Ch.*, **5**, 201; Joly and Leidié, *C. r.*, **112**, 793; Langness, *J. Am. Ch. S.*, **29**, 469.

Few attempts have been made to determine this metal electrolytically. Its separation from an acid phosphate solution is very rapid and complete. A current of 0.18 ampere will answer perfectly for the purpose. As the decomposition progresses, the beautiful purple color of the liquid gradually disappears, and the solution is colorless when the precipitation is finished. The deposition of the rhodium should be made upon copper-coated dishes. The metal is generally black in color, very compact, and perfectly adherent. Hot water may be used for washing purposes.

Joly precipitates the metal from solutions acidulated with sulphuric acid.

The Rapid Precipitation of Rhodium With the Use of a Rotating Anode.

The electrolyte consisted of an aqueous solution of rhodium sodium chloride (0.0576 gram of metal) to which were added 2.5 c.c. of sulphuric acid (dil. 1 : 10). It was diluted to 100 c.c. with boiling water, and electrolyzed, using a *spiral* (p. 78) anode; while in the last three determinations a *dish* (p. 78) anode was employed. The rhodium was deposited on a silver-coated platinum dish.

No.	VOLTS.	AMPERES.	TIME, MIN.	WT. OF RH. IN GRAMS.
1	7	8	15	0.0577
2	7.5	8	10	0.0580
3	8	9	10	0.0575
4	8	9	7	0.0576
5	8	15	4	0.0573
6	6	11	4	0.0563
7	7	14	4	0.0567

The deposits were adherent and black in color.

The *rate of precipitation* was determined with a solution containing 0.1153 gram of metal. The current equaled 15 amperes and the pressure 7 volts. The results were:

In 1 minute.....	0.0896 gram of metal
In 2 minutes.....	0.1006 gram of metal
In 3 minutes.....	0.1104 gram of metal
In 4 minutes.....	0.1128 gram of metal
In 5 minutes.....	0.1141 gram of metal
In 8 minutes.....	0.1152 gram of metal
In 10 minutes.....	0.1153 gram of metal

MOLYBDENUM.

LITERATURE.—Gahn, Gilbert's Ann., 14, 235; Férèe, C. r., 122, 733; Smith, Am. Ch. Jr., 1, 329; Hoskinson and Smith, *ibid.*, 7, 90; Kollock and Smith, J. Am. Ch. S., 23, 669; Exner, J. Am. Chem. S., 25, 904; Myers, J. Am. Chem. S., 26, 1129; Chilesotti, Gazz.

Chim. ital., 33, 349, 362; *Z. f. Elektrochem.*, 12, 146; *Chilesotti and Rozzi*, *Gazz. Chim. ital.* (1905), 35, 228; *Wherry and Smith*, *J. Am. Ch. S.*, 29, 806; *Chilesotti*, *Z. f. Elektrochem.*, 12, 146.

When the electric current acts upon ammoniacal or feebly acid solutions of ammonium molybdate, a beautiful iridescence appears; as the action continues this assumes a black color, and the deposit becomes more dense. It is the hydrated sesquioxide which is precipitated. At the time when these observations were made, experiments were instituted to determine the metal. The results, while quantitative in character, were obtained with the consumption of too much time to permit of the method being generally applied. Recently attention has again been given to the subject in this laboratory. Sodium molybdate ($\text{Na}_2\text{MoO}_4 \cdot 2\text{H}_2\text{O}$) was dissolved so that 0.1302 gram of molybdenum trioxide was present in 125 c.c. of solution, which was exposed for several hours to the action of a current of 0.1 ampere and 4 volts. The temperature of the electrolyte was 75°C . No precipitation occurred upon either electrode. Upon adding two drops of concentrated sulphuric acid to the liquid, it at once assumed a dark blue color. As the current continued to act, this color disappeared and the cathode was coated with a black deposit—the hydrated sesquioxide. On removing the colorless liquid and testing it with ammonium sulphocyanide, zinc, and hydrochloric acid, evidences of the presence of molybdenum failed to appear. The deposit was brilliant black in color and so adherent that it could be washed without detaching any particles. Usually the colorless liquid was removed with a siphon, cold water being introduced without interrupting the current. The deposit was not dried, but dissolved while moist from off the dish in dilute nitric acid, and the solution carefully evaporated to dryness, the residue being heated upon an iron plate to expel the final traces of acid. White molybdic acid remained. If blue spots appeared in the mass,

they were removed by moistening the residue with nitric acid and evaporating a second time to dryness. This procedure was adopted in all the experiments. It was not possible to obtain concordant results by merely drying the hydrate at a definite temperature. The same was true in regard to the ignition of the hydrate to trioxide. Loss occurred from sublimation and volatilization.

RESULTS.

	MOLYBDENUM TRIOXIDE PRESENT, IN GRAMS.	SULPHURIC ACID ADDED. C.C.	DILUTION. C.C.	TEMPERATURE °C.	CURRENT.	VOLTS.	TIME. HOURS.	MOLYBDENUM TRIOXIDE FOUND IN GRAMS.	ERROR, IN GRAMS.
1	0.1302	0.1	125	70	N.D. _{.107} = 0.022A	2.0	4¾	0.1299	-0.0003
2	0.1302	0.1	125	80	N.D. _{.107} = 0.045A	2.25	2½	0.1302	—
3	0.1302	0.1	125	70	N.D. _{.107} = 0.04 A	2.2	4½	0.1302	—
4	0.2604	0.2	125	75	N.D. _{.107} = 0.04 A	2.0	7	0.2603	-0.0001
5	0.1541	0.2	125	85	N.D. _{.107} = 0.04 A	1.9	2¼	0.1541	—
6	0.1541	0.2	125	80	N.D. _{.107} = 0.035A	2.1	4	0.1540	-0.0001

The method is accurate, is easy of execution, and requires comparatively little time.

Chilesotti and Rozzi have applied this method in the estimation of molybdenum and have met with excellent success. At first, in the presence of alkali metals, they observed that these were carried into the molybdenum sesquioxide, but subsequently discovered that by addition of sulphuric acid any alkali co-precipitated with the molybdenum was reduced to nil. In the presence of 0.75 per cent. of potassium sulphate, 0.4 per cent. to 0.5 per cent. of sulphuric acid was sufficient to arrest all alkali precipitation.

It seemed that the method could be made useful in the determination of the molybdenum content of the mineral molybdenite. By fusing the latter with a mixture of pure alkaline carbonate and nitrate, sodium molybdate and sul-

phate would be formed. If the sulphur is not to be determined, after dissolving out the fusion with water, and filtering off the insoluble oxides, acidulate the alkaline liquid with dilute sulphuric acid and proceed with the electrolysis; but in cases where an estimation of the sulphur is desired, it was thought that acetic acid would answer for the purpose of acidulation. To ascertain the latter fact the experiments given below were instituted. The solution, acidified with this acid, does not acquire a blue color on passing the current through it. The deposit of hydrated oxide is very adherent and readily washed. A longer time is necessary for the complete precipitation. It is also advisable not to add the entire volume of acetic acid at first, but to introduce it gradually from time to time, from a burette.

RESULTS.

	MOLYBDENUM TRIOXIDE PRESENT, IN GRAMS.	TWENTY-NINE PER CENT. ACETIC ACID ADDED. C.C.	DILUTION. C.C.	TEMPERATURE. °C.	CURRENT.	VOLTS.	TIME. HOURS.	MOLYBDENUM TRIOXIDE FOUND, IN GRAMS.	ERROR, IN GRAMS.
1	0.1541	1	125	85	N.D. _{.107} = 0.075A	4.4	7½	0.1541	—
2	0.1541	1	125	85	N.D. _{.107} = 0.075A	4.4	3	0.1540	-0.0001
3	0.1541	1	125	80	N.D. _{.107} = 0.05 A	2.5	6	0.1543	+0.0002

In the last experiment, 5 grams of sodium acetate were added in order to increase the conductivity of the solution and to ascertain what effect an excess of this salt would have, because, if the acetic acid were used to acidify the alkaline solution obtained by the decomposition of molybdenite, a great deal of this salt would be present. The concordant results justified the next step, which was to decompose weighed amounts of pulverized molybdenite with sodium carbonate and nitrate, then take up the fusion with water, filter out the insoluble oxides, acidify with acetic acid, boil off the carbon

dioxide, and electrolyze. The liquid poured off from the deposit of the sesquihydroxide was heated to boiling and precipitated with a hot solution of barium chloride.

	MOLYBDENITE, IN GRAMS.	MOLYBDENUM FOUND, IN PER CENT.	SULPHUR FOUND, IN PER CENT.
1	0.2869	57.37	38.28
2	0.1005	57.15	38.33
3	0.1388	56.83	37.87

The Rapid Precipitation of Molybdenum Sesquioxide With the Use of a Rotating Anode.

The procedure was the same as described under all the other metals. The solutions were acidulated with sulphuric acid and the conditions were as given here.

No.	MoO ₃ PRESENT IN GRAMS.	DILUTE SULPHURIC ACID (1:10) IN C.C.	POTASSIUM SULPHATE IN GRAMS.	CURRENT IN AMPERES.	VOLTS.	TIME.	MoO ₃ FOUND.
1	0.1200	2	1	5	16	30	0.1197
2	0.1200	2	1	5	16	5	0.0335
3	0.1200	2	1	5	16	9	0.0603
4	0.1200	2	1	5	16	15	0.1026
5	0.1200	2	1	5	16	20	0.1190
6	0.1200	2	1	5	16	25	0.1198

The total dilution never exceeded 100 cubic centimeters. The rapidity with which the oxide separates and the ease with which the estimation is made make this electrolytic procedure vastly superior to other methods of determination.

The Rapid Precipitation of Molybdenum With the Use of a Mercury Cathode.

On electrolyzing an aqueous solution of molybdenum trioxide, acidulated with sulphuric acid, with a cathode of

mercury, molybdenum itself enters fully into the cathode and forms with it a brilliant white amalgam. Therefore this metal can be directly weighed in this way. A water solution of sodium molybdate, acidulated with sulphuric acid, will serve also for this purpose. Accordingly, portions of sodium molybdate (10 cubic centimeters of which contained 0.0950 gram of metal) were electrolyzed under the following conditions. The anode was stationary.

DETERMINATION OF MOLYBDENUM.

	MOLYBDENUM PRESENT IN GRAMS.	MOLYBDENUM FOUND IN GRAMS.	NO. OF CELL USED.	SULPHURIC ACID (SP. G. 1.832) PRESENT IN DROPS.	CONDITIONS.				
					TIME. HOURS.	AMPERES.	VOLTS.	AMPERES.	VOLTS.
1	0.0950	0.0950	3	13	14	1.2	6	1.6	6.5 (2 hrs.)
2	0.0950	0.0950	3	13	22	1.2	6	1.6	6 (2 hrs.)
3	0.1900	0.1906	2	30	18	1.6	5.5	1.4	7 (4 hrs.)
4	0.1900	0.1903	2	25	20	1.6	5.5	1.4	7 (4 hrs.)

The ordinary steps, observed in treatment of the amalgam with other metals, are observed here.

This method of determining molybdenum affords an excellent means of separating it from other metals (see p. 272).

GOLD.

LITERATURE.—Luckow, *Z. f. a. Ch.*, **19**, 14; Brugnattelli, *Phil. Mag.*, **21**, 187; Smith, *Am. Ch. Jr.*, **13**, 206; Smith and Muhr, *Am. Ch. Jr.*, **13**, 417; Smith, *Jr. An. Ch.*, **5**, 204; Smith and Wallace, *Ber.*, **25**, 779; Frankel, *Jr. Fr. Ins.*, 1891; Persoz, *Ann. Chim. Pharm.*, **65**, 164; Rüdorff, *Z. f. ang. Ch.*, **1892**, p. 695; Exner, *J. Am. Ch. S.*, **25**, 905; Medway, *Am. Jr. Science* [4th series] **18**, 58; Perkin and Preble, *Elektrochemische Zeitschrift*, **11**, 69; Miller, *J. Am. Ch. S.*, **25**, 896; Withrow, *J. Am. Ch. S.*, **27**, 1545; **28**, 1350.

This metal can be completely deposited from solutions containing it in the form of a double cyanide, sulphaurate,

and sulphocyanide, as well as in the presence of free phosphoric acid. In this laboratory the cyanide and sulphaurate have received the most consideration. An example will illustrate the conditions with which good results may be obtained from the double cyanide: A solution contained 0.1162 gram of metallic gold; to it were added 1.5 grams of potassium cyanide and 150 c.c. of water. It was heated to 55° and electrolyzed with a current of $N.D._{100} = 0.38$ ampere and 2.7-3.8 volts. The precipitation was complete in one and one-half hours. The gold deposit weighed 0.1163 gram. It was washed both with cold and hot water. The metal may be precipitated upon silver-coated or copper-coated platinum vessels, or directly upon the sides of the platinum dish. If the last suggestion is followed, dissolve off the gold, after weighing, by introducing very dilute potassium cyanide into the dish, and then connect the latter with the anode of a battery yielding a very feeble current.

Perkin and Preble dissolve the gold from off the platinum by pouring into the dish 100 c.c. of water containing two to three grams of potassium cyanide and adding to this five cubic centimeters of hydrogen peroxide. In the cold two to three minutes will be required for the solution of the gold. One minute is sufficient if the solution be gently heated.

The deposition of gold from a sodium sulphide solution (sp. gr. 1.18) is just as satisfactory as that described in the last paragraph. The current should equal 0.1-0.2 ampere for a total dilution of about 125 c.c. The precipitated metal is very adherent and of a bright yellow color.

The Rapid Precipitation of Gold With the Use of a Rotating Anode.

Use a *double cyanide electrolyte* and follow the conditions given in the subjoined table.

GOLD IN GRAMS.	KCN IN GRAMS.	CURRENT, N.D. ₁₀₀ =A.	VOLTS.	TIME IN MINUTES.	GOLD FOUND, GRAMS.
0.0290	1.0	5	11	10	0.0289
0.0725	2.0	5	11	11	0.0725
0.1450	1.5	5	11	7	0.1447

The anode should perform 500 revolutions per minute. In the examples given the deposits were excellent.

Withrow, in developing this study, found the following results:

No.	GOLD TAKEN, GRAM.	KCN GRAMS.	DILUTION, C.C.	CURRENT, AMPERES.	VOLTS.	SPEED PER MINUTE.	TIME, MINUTES.	GOLD FOUND, GRAMS.
I	0.5222	5	60	10	10-8	800	10	0.5216
2	0.5222	5	60	10-10.2	10-7.3	800	12	0.5226
3	0.5222	2.5	55	10-10.8	14.5-9.6	800	10	0.5222
4	0.5222	2.5	55	10-10.3	14-9.4	810	12	0.5234
5	0.5465	3.5	60	10-10.5	8.3-7	790	12	0.5461
6	0.5465	5	60	10-10.2	9.3-8.3	790	1	0.1891
7	0.5465	5	60	10.2-10.5	8.3-7	800	3	0.4341
8	0.5465	5	60	10-10.3	9.6-7.1	825	5	0.5286
9	0.5465	5	60	10	8.6-6.7	780	7	0.5437
10	0.5465	5	60	10.3-10	8.3-6.3	790	11	0.5468
11	0.5465	5	60	16	7.8-6.8	790	12	0.5467

The rate of precipitation is readily determined from these data.

In an alkaline sulphide electrolyte results may be obtained which are just as satisfactory. In using this electrolyte bring the alkaline sulphide into the cathode dish, rotate the anode and then run in from a pipette the solution of gold chloride.

RESULTS.

No.	GOLD TAKEN, GRAMS.	Na ₂ S, C.C.	DILUTION, C.C.	CURRENT, AMPERES.	VOLTS.	SPEED PER MINUTE.	TIME, MINUTES.	GOLD FOUND, GRAM.
1	0.2878	15	60	10-8.8	7.6-7.2	810	7	0.2891
2	0.2878	30	60	10.1-10.3	6.9-6	840	7	0.2879
3	0.2878	30	60	9.8-10.1	7.8	830	7	0.2897
4	0.2878	15	60	10-9.8	11.6-11.1	840	7	0.2898
5	0.2878	20	60	10	11.6-9	800	7	0.2905
6	0.2878	30	60	10.2-10.5	8.8-7.4	830	7	0.2883
7	0.2878	20	60	10.1-10	9.1-8.2	850	7	0.2885
8	0.2878	15	60	10	11.5-10	840	7	0.2887
9	0.2878	30	60	10.1-10	9.4-8.5	850	1	0.1165
10	0.2878	30	60	10	8-7	850	6	0.2870
11	0.2878	30	60	10-10.2	9-7.9	850	3	0.2365

The Rapid Precipitation of Gold With the Use of a Rotating Anode and Mercury Cathode.

Introduce the gold chloride solution into the mercury cup. Place upon it 10 cubic centimeters of toluene. Electrolyze with a current of from 2 to 3 amperes and 10 volts. The gold is precipitated very rapidly. The other details of manipulation are analogous to those recited under preceding metals.

Five minutes are more than enough to precipitate from 0.15 to 0.2 gram of metal.

TIN.

LITERATURE.—Luckow, *Z. f. a. Ch.*, **19**, 13; Classen and v. Reiss, *Ber.*, **14**, 1622; Gibbs, *Ch. N.*, **42**, 291; Classen, *Ber.*, **17**, 2467; **18**, 1104; Bongartz and Classen, *Ber.*, **21**, 2900; Rüdorff, *Z. f. ang. Ch.*, **1892**, 199; Classen, *Ber.*, **27**, 2060; Engels, *Z. f. Elektrochem.*, **2**, 418; Freudenberg, *Z. f. ph. Ch.*, **12**, 121; Heidenreich, *Ber.*, **28**, 1586; Campbell and Champion, *J. Am. Ch. S.*, **20**, 687; Klapproth, *Dissertation*, Hannover, 1901; Classen, *Z. f. Elektrochem.*, **1**, 289; Henz, *Z. f. anorg. Ch.*, **37**, 40; Fischer and Boddaert, *Z. f. Elektrochem.*, **10**, 951; Medway, *Am. Jour. Science* [4th series], **18**, 57; Dannel and Nissenon, *Internationaler Congress für angew. Chemie* (1903), *Band 4*, 678; Exner, *J. Am. Chem. S.*, **25**, 905; Kollock and

Smith, J. Am. Ch. S., 27, 1532 and 1546; Witmer, J. Am. Ch. S., 29, 473; Pasztor, Elektroch. Z., 16, 281; Schürman, Ch. Z., 34, 1117.

Tin may be deposited from a solution of ammonium tin oxalate. It is advisable not to use potassium oxalate in the electrolysis, for then a basic salt is liable to separate upon the anode.

Classen adds 120 c.c. of a saturated ammonium oxalate solution to the liquid containing 0.9–1.0 gram of stannic ammonium chloride, then electrolyzes at 30°–35° with a current of 0.3–0.6 ampere and 2.8–3.8 volts. Acid ammonium oxalate must be added from time to time if large quantities of metal are to be precipitated. The tin separates in a brilliant, white, adherent form. It is washed and dried in the usual way. The time required for precipitation is generally nine hours. This factor, however, can be reduced, as is evident from the following example: Acidulate the solution containing 0.4 gram of tin and 4 grams of ammonium oxalate with 9–10 grams of oxalic acid; heat to 60°–65°, and electrolyze with $N.D._{100} = 1-1.5$ amperes. Acetic acid may replace the oxalic acid. Fusion with potassium acid sulphate will remove the tin from the dish.

Henz dissolves the tin deposit in nitric acid, containing an excess of oxalic acid, or fills the dish with dilute hydrochloric acid and adds metallic zinc.

Campbell and Champion use the oxalate method in determining tin in its ores. Fuse 1 gram of the ore with 5–6 grams of a mixture of equal parts of soda and sulphur for an hour and a half, at full red heat. This is done in a porcelain crucible, placed within a second crucible of the same material. Dissolve the sulphostannate in from 40–50 c.c. of hot water, filter, and re-fuse the residue as before. Add hydrochloric acid, to faint acid reaction, to the combined solutions of sulpho-salts. Stannic sulphide will be precipitated. Boil off the hydrogen sulphide, add 10 c.c. of hydrochloric acid (sp. gr. 1.20), and

then gradually introduce 2-3 grams of sodium peroxide until a clear liquid is obtained. Boil for three minutes, filter out the separated sulphur, add ammonia water to permanent precipitation and 50 c.c. of a 10 per cent. acid ammonium oxalate solution. Electrolyze with a current of $N.D._{100} = 0.1$ ampere and 4 volts. Allow the current to act through the night. The deposit will be light in color and very adherent.

Classen has discovered that a tin solution containing an excess of ammonium sulphide, largely diluted with water, yields a quantitative deposition of the metal when exposed to the action of a current from two Bunsen cells. In dilute sodium or potassium sulphide solution the tin precipitation is incomplete, and whenever such conditions exist, the sodium or potassium salt must be converted into ammonium sulphide. To this end the liquid is mixed with about 25 grams of ammonium sulphate, free from iron, and the solution then carefully warmed in a covered vessel until the evolution of hydrogen sulphide ceases; after which the liquid is heated to incipient ebullition for fifteen minutes. Allow it to cool, dissolve any sodium sulphate which may have separated by the addition of water, and electrolyze. The tin separates in a gray, dense layer. Wash it with water and alcohol. At times sulphur sets itself upon the tin deposit; this is difficult to remove, but can be detached, after washing the deposit with alcohol, by gently applying a linen handkerchief. Having potassium sulphostannate, Classen considers it advisable to convert the tin into oxalate and then electrolyze. He employs two methods. One will be given here:—

Decompose the greater portion of the sulpho-salt with dilute sulphuric acid (the liquid must remain alkaline) to get rid of most of the sulphur as hydrogen sulphide, then oxidize with hydrogen peroxide until the metastannic acid produced is pure white in color. Acidulate with sulphuric acid, neutralize with ammonia water, and again add hydrogen peroxide.

Filter out the stannic acid when it has subsided, dissolve in oxalic acid and ammonium oxalate, and electrolyze with the conditions given in the preceding paragraphs.

According to Carl Engels, add 0.3 to 0.5 gram of hydroxylamine hydrochloride or sulphate, 2 grams of ammonium acetate, and 2 grams of tartaric acid to the solution of the tin salt, dilute with water to 150 c.c., heat to 60°–70°, and electrolyze with $N.D._{100} = 1$ ampere.

Pasztor (*Elektroch. Z.* 16, 281) has likewise shown that with a current density of 8 amperes per sq. dm. at 80°, tin may be rapidly and quantitatively deposited from a tartaric acid solution. The electrolyte works best with 4 to 6 grams of tartaric acid, 2 grams of ammonium acetate, and 1 gram of hydroxylamine hydrochloride. With a cylindrical wire gauze cathode the current may be run up to 12 amperes and external heating done away with. Pasztor also states that stannous sulphide, dissolved in a hot solution of ammonium chloride in hydrochloric acid, gives a clear solution from which the tin may be determined electrolytically.

The Rapid Precipitation of Tin With the Use of a Rotating Anode.

In this laboratory no difficulty was experienced in using a solution of stannous ammonium chloride containing an excess of a hot saturated solution of ammonium oxalate. The anode performed 300 revolutions per minute. The proper conditions are shown in a few examples which follow:—

TIN PRESENT IN GRAMS.	AMMONIUM OXALATE HOT, SATURATED SOLUTION IN C.C.	CURRENT N. D. ₁₀₀ IN AMPERES.	VOLTS.	TIME. MINUTES.	TIN FOUND IN GRAMS.
0.5396	100	5	5	13	0.5392
0.2193	100	5	5.5	15	0.2193
0.4355	100	5-8	5.5-6.5	18	0.4353
1.0800	100	5	4.5	20	1.0801

In using an *ammonium sulphide electrolyte* a definite volume of the alkaline sulphide was placed in the cathode dish and the solution of stannous chloride pipetted into it. Hot water was then added to give 100 cubic centimeters volume to the liquid. The anode was made to rotate 500 times per minute, the dish was covered and the current applied. The conditions are exhibited in the following experiments:

AMMONIUM SULPHIDE (SP. GR. 0.985).	CURRENT N. D. ₁₀₀ IN AMPERES.	VOLTS.	TIME IN MINUTES.	TIN PRESENT IN GRAMS.	TIN FOUND IN GRAMS.
An excess.	5.4	7	10	0.1357	0.1052
“ “	4	7.5	20	0.1357	0.1350
“ “	4	7.5	20	0.1357	0.1354
7 c.c.	4.5	8	25	0.1357	0.1358
14 “	5.4	7.5	25	0.2714	0.2717

The deposits were like polished silver. When stannic chloride was the salt used, the metal deposit was slightly crystalline but perfectly adherent. The speed of rotation of the anode had little or no effect on the character of the deposit.

The best conditions for 0.2 gram of metal were found to be 15 to 20 cubic centimeters of ammonium sulphide (sp. gr. 0.985) and a current of $N.D._{100} = 5.5$ amperes and 9 volts.

The *rate of precipitation* was determined with a solution containing 0.5070 gram of metal. It was found to be:—

In 1 minute.....	0.0704 gram
In 2 minutes.....	0.1276 gram
In 3 minutes.....	0.1922 gram
In 4 minutes.....	0.2475 gram
In 5 minutes.....	0.2927 gram
In 10 minutes.....	0.4796 gram
In 15 minutes.....	0.4917 gram
In 20 minutes.....	0.5070 gram

The current in these trials was $N.D._{100} = 5$ amperes and 7.5 to 10 volts.

The Rapid Precipitation of Tin With the Use of a Rotating Anode and Mercury Cathode.

Arrange the mercury cup as under the preceding metals. Introduce into it the tin salt, preferably the sulphate (5 cubic centimeters = 0.4106 gram), add a little concentrated sulphuric acid and electrolyze with a current of from 2 to 4 amperes and 5 to 4 volts. Conditions almost analogous to these are found in the following examples. They are reliable and give results that are dependable.

EXPERIMENT.	TIN PRESENT. GRAM.	VOLUME. C.C.	SULPHURIC ACID. C.C.	CURRENT. AMPERS.	VOLTS.	TIME. MINUTES.	TIN FOUND. GRAM.	ERROR. GRAM.
1	0.4106	5	0.2	2-4	5	10	0.4109	+0.0003
2	0.4106	5	0.2	4	5	9	0.4114	+0.0008
3	0.4106	5	0.2	4	5-4.5	9	0.4109	+0.0003
4	0.4106	6	0.5	4	5	6	0.4106	—
5	0.4106	5	0.25	4	5	6	0.4106	—
6	0.8212	10	0.5	6	5.5	9	0.8210	-0.0002
7	0.4106	10	0.75	5	5	8	0.4107	+0.0001
8	0.4106	7	0.05	5	5	7	0.4106	—
9	0.4106	7	0.25	5	5	10	0.4107	+0.0001

The rate of precipitation is:

In 2 minutes.....	0.2997 gram of tin
In 4 minutes.....	0.3974 gram of tin
In 5 minutes.....	0.4060 gram of tin
In 6 minutes.....	0.4106 gram of tin

On using a current of 5 amperes and 5 to 4 volts, 0.8212 gram of tin was precipitated in eight minutes.

Stannous chloride may also be used as the electrolyte if the layer of toluene (p. 93) is placed over it. To illustrate, the following examples may be cited:

1. Five cubic centimeters of stannous chloride (= 0.0800 gram of tin) and 10 cubic centimeters of toluene were elec-

trolyzed with a current of 2 to 3 amperes and 7 to 6 volts. In ten minutes (a) 0.0798 gram and (b) 0.0806 gram of metal were precipitated.

2. Ten cubic centimeters of stannous chloride (=0.1600 gram of tin) and ten cubic centimeters of toluene were electrolyzed with a current of 2 to 3 amperes and 7 to 6 volts. In fifteen minutes 0.1595 and 0.1600 gram of metal were obtained.

ANTIMONY.

LITERATURE.—Wrightson, Z. f. a. Ch., 15, 300; Parodi and Mascazzini, Z. f. a. Ch., 18, 588; Luckow, Z. f. a. Ch., 19, 13; Classen and v. Reiss, Ber., 14, 1622; 17, 2467; 18, 1104; Lecrenier, Ch. Z., 13, 1219; Chittenden, Pro. Conn. Acad. Sci., 8; Vortmann, Ber., 24, 2762; Rüdorff, Z. f. a. Ch., 1892, 199; Classen, Ber., 27, 2060; Henz, Z. f. anorg. Ch., 37, 29; Ost and Klapproth, Z. f. ang. Ch. (1900), 827; Hollard, B. Soc. Chim. Paris [series 3], 29, 262, and Ch. N., 87, 282; Fischer, Ber., 36, 2348; Z. für anorg. Ch., 42, 363; Law and Perkin, Trans. Faraday Society (1905), 1, 262; Danneel and Nissen, Internationaler Congress für angewandte Ch. (1903), Band 4, 678; Exner, J. Am. Ch. S., 25, 905; Fischer and Boddaert, Z. f. Elektrochem., 10, 950; Langness and Smith, J. Am. Ch. S., 27, 1524; Dormaar, Z. f. anorg. Ch., 53, 349; Foerster and Wolf, Z. f. Elektrochem., 13, 205; Sand, Z. f. Elektrochem., 13, 326; O. Scheen, Z. f. Elektroch., 14, 257; E. Cohen, Z. f. Elektroch., 14, 301.

Antimony, when precipitated from a solution of its chloride, or from that of antimony potassium oxalate, does not adhere well to the cathode. It is deposited very slowly from a solution of potassium antimonyl tartrate. Its deposition from a cold ammonium sulphide solution is satisfactory, but the use of this reagent for this purpose is not pleasant, especially when several analyses are being carried out simultaneously. For this reason potassium or sodium sulphide has been substituted. The alkaline sulphide used must not contain iron or alumina.

The antimony solution, mixed with 80 c.c. of sodium sulphide (sp. gr. 1.13-1.15), should be diluted with water to 125 c.c. and acted upon at 60°-65° with a current of N.D.₁₀₀ = 1

ampere and 1.1–1.7 volts. The metal will be fully precipitated in two hours. The deposit should be treated in the usual way with water and pure alcohol. Dry at 90°. To ascertain when all of the metal has been deposited, incline the dish slightly, thus exposing a clean platinum surface. If this remains bright for half an hour the precipitation is finished. In separating antimony from the heavy metals—*e. g.*, lead—it happens that alkaline sulphides containing polysulphides are used, or are produced. To remove these Classen proposed adding to the antimony polysulphide mixture, already in a weighed platinum dish, an ammoniacal solution of hydrogen peroxide, and warming the same until the liquid becomes colorless. When this is accomplished, even if a precipitate has been produced, add, after cooling, the solution of sodium monosulphide, and electrolyze as previously directed.

Lecrenier writes as follows relative to the preceding method: The precipitation is all that one can desire, provided the solution of the sulpho-salt is absolutely free from polysulphides, otherwise it is incomplete. The antimony sulphide obtained in the ordinary course of analysis always contains sulphur, and this must be eliminated. To remove the various inconveniences connected with the method add 50–70 c.c. of a 25 per cent. solution of sodium sulphite to the solution after the addition of the excess of sodium sulphide, then heat the liquid to complete decolorization; allow to cool, after which the current is conducted through the liquid. This can rise to 0.5 ampere without impairing the result; but it is not best, as the precipitated metal is then very coherent. It is better to use a current of 0.25 ampere. When the quantity of antimony does not exceed 0.2 gram, the deposit will be adherent and free from sulphur; wash with water, alcohol, and ether. Sulphur will separate upon the anode, despite the presence of an excess of sodium sulphite. This, however, does not affect the result.

The method of Classen suffers in several points:

1. The bath pressure falls as the electrolysis proceeds, because of the accumulation in it of sodium polysulphide.

2. If the electrolysis is not interrupted at the proper moment, antimony already precipitated will be again dissolved by the polysulphide which has diffused toward the cathode (Z. f. ang. Ch., 1897, 325). Ost and Klapproth have sought by the use of a diaphragm to circumvent these objectionable features. To this end they use (Fig. 34) a roughened dish, *a*, in which is suspended a dish-shaped diaphragm, *b* (a Pukall

FIG. 34.

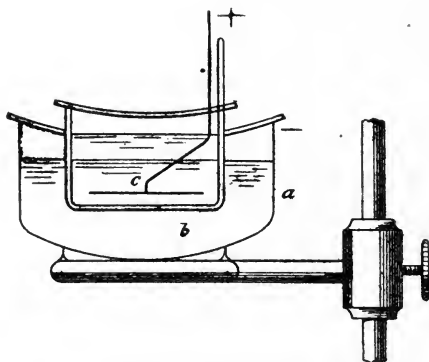

porous cup, Ber., 26, 1159). A strip of platinum, *c*, within the diaphragm, is the anode, while the platinum dish itself constitutes the cathode. Cover-glasses are placed over both dishes. The liquids experimented upon were a solution of Schlippe's salt (=0.0985 gram of antimony in 10 c.c.) and a solution of pure sodium sulphide (195 grams Na_2S = 200 grams NaOH to the liter). In the first experiments the antimony was equally distributed in the whole electrolyte. The cathode chamber contained 85 c.c. and the anode chamber 40 c.c. of the solution, which had 0.0985 gram of antimony in 125 c.c.,

with varying amounts of sodium sulphide. The liquid covered about 100 sq. cm. of the surface of the dish:

EXPERIMENT.	Na ₂ S SOLUTION.	TEMPERATURE.	BATH PRESSURE AT ONE AMPERE.		CURRENT STRENGTH IN AMPERES.		ANTIMONY PRECIPITATED.
			BEGINNING VOLTS.	END VOLTS.	AT BEGINNING.	AT END.	
1	5 c.c.	70°	3.8	3.0	0.7	0.3	0.0675
2	50 "	Cold.	1.9	3.8	0.5	0.4	0.0725
3	80 "	70°	2.5	1.7	1.0	1.0	0.0685
4	80 "	70°	1.7	1.3	1.0	1.0	0.0720

When the electrolysis was finished, antimony could not be found in the cathode liquid from any one of the four experiments, whereas in the anode chamber it was still in solution, and in experiment 1 it had been precipitated on the anode in the form of antimony pentasulphide.

These experiments indicated then that the current is not able to carry antimony ions from the anode into the cathode chamber.

In the next series of experiments the 10 c.c. of antimony solution (=0.0985 gram of metal) were placed in the cathode chamber alone:

EXPERIMENT.	Na ₂ S SOLUTION.	TEMPERATURE.	BATH PRESSURE AT ONE AMPERE.		TIME.	ANTIMONY PRECIPITATED.
			BEGINNING VOLTS.	AT END VOLTS.		
1	50 c.c.	Cold.	4.2	3.7	5 hours.	0.0970
2	50 c.c.	70°	2.0	3.8	3 "	0.0984
3	80 c.c.	70°	2.5	1.7	2 "	0.0990
4	50 c.c.	70°	1.8	1.8	1½ "	0.0990

The results show a quantitative precipitation of the antimony. None of it could be found either in the cathode or anode liquid.

On placing the antimony in the anode chamber alone, not a particle of metal was deposited on the cathode.

When the antimony was placed in the cathode chamber only and varying quantities of sodium sulphide solution were mixed with it, remarkable differences were observed. In the presence of much sodium sulphide and accompanying low bath pressure all of the antimony was precipitated at the cathode, while with little sodium sulphide and consequent high bath pressure, a small amount of antimony wandered through the diaphragm and was deposited at the anode in the form of antimony sulphide.

These experiments show how a successful antimony determination may be made. No difficulties attend its estimation in this way.

To dissolve the antimony deposit from off the dish, Ost recommends nitric acid, containing tartaric acid.

Vortmann, recognizing the fact that it is difficult to obtain an adherent deposit of antimony when the quantity of metal in solution exceeds 0.16 gram, has combined the method of Smith, who first pointed out that mercury could be deposited very satisfactorily from its solution in sodium sulphide, with his knowledge that antimony could be precipitated from a similar solution, and hence recommends the determination of the antimony in the form of an amalgam. No difficulties attend this procedure. Two parts of mercury should be present for every part of antimony. The latter must also be present in solution as higher oxide; to this end digest the antimonious solution with bromine water, and afterward add the sodium sulphide containing sodium hydroxide. Electrolyze with a current of from 0.2 to 0.3 ampere. The amalgam can be washed in the usual way.

Law and Perkin recommend precipitating antimony from an ammoniacal solution of its tartrate. To this end they heat

the electrolyte to 75° and act upon it with a current of N.D.₁₀₀ = 0.2 to 0.5 ampere and 2.5 to 3 volts.

Almost every analyst has experienced at the out-start, difficulties similar to those described and many have made suggestions of value to escape them. Thus, Henz, recognizing the virtue of the methods adopted by Lecrenier and Ost and Klapproth to get rid of the disturbing influences due to the polysulphide, found an excellent reducing agent in potassium cyanide. Hollard (1900), however, was the first to use this reagent, antedating Henz, Fischer and Exner. Potassium cyanide rapidly reduces polysulphides to monosulphide, forming a sulphocyanide:

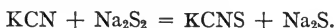

In this respect one gram of potassium cyanide will be as effective as four grams of sodium sulphite. It is also much more soluble. One to two grams will suffice to keep colorless the bath for the precipitation of 0.1 gram of antimony.

While Henz obtained most satisfactory deposits of antimony in this way he observed—as have others—that often the results were high; in some instances from 2 to 3 per cent. He thought possibly there was here a constant for which allowance could be made. Dormaar has since given this point very careful study and found that the apparent increase in the found antimony, rising with the current strength and the quantity of metal present, is due in large part to the presence of oxygen in the deposit and some occluded sodium sulphide.

It is probable that working with from 0.1 to 0.2 gram of metal this oxidation has been too slight to affect the final result, so it has been usually neglected.

The Rapid Precipitation of Antimony With the Use of a Rotating Anode.

Exner, working in this laboratory, first performed this determination. He added to a solution of antimony chloride a

slight excess of sodium hydroxide, sodium hydrosulphide and potassium cyanide, then electrolyzed with conditions like those given below.

ANTIMONY IN GRAMS.	NaOH 10% SOLU- TION IN C.C.	NaSH C.C.	KCN GRAMS.	CURRENT N.D. ₁₀₀ = AMPERES.	VOLTS.	TIME IN MINUTES.	Sb.
0.3042	30	20	2	5	4.5	20	0.3042

The anode made 400 to 500 revolutions per minute.

Later Miss Langness proceeded as follows in applying the above procedure. To a solution of antimony chloride (= 0.2405 gram of metal) were added 15 cubic centimeters of sodium sulphide (sp. gr. 1.18), 3 grams of potassium cyanide, 1 cubic centimeter of sodium hydroxide (10 per cent.), the solution was diluted with water to 70 cubic centimeters, heated nearly to boiling and electrolyzed with N.D.₁₀₀ = 6 amperes and 3.5 to 4 volts. The metal was all deposited in fifteen minutes. Numerous determinations were made. The deposits in all of them were perfectly adherent. There was no sponginess. The metal was bright gray in color. On using sand-blasted platinum dishes from 0.4847 gram to 1.0000 gram of metal could be precipitated in a beautiful and very compact form in from twenty to twenty-five minutes.

The *rate of precipitation*, determined with a current of 6.5 amperes and 3.5 volts, was as follows:

In 1 minute.....	0.0652 gram of antimony was obtained
In 2 minutes.....	0.1007 gram of antimony was obtained
In 3 minutes.....	0.1575 gram of antimony was obtained
In 4 minutes.....	0.1969 gram of antimony was obtained
In 5 minutes.....	0.2140 gram of antimony was obtained
In 6 minutes.....	0.2251 gram of antimony was obtained
In 7 minutes.....	0.2331 gram of antimony was obtained
In 8 minutes.....	0.2369 gram of antimony was obtained
In 15 minutes.....	0.2405 gram of antimony was obtained

The omission of the sodium hydroxide from the electrolyte works no harm. It is possible also to reduce the volume of sulphide to ten cubic centimeters, but there should then be a reduction of the alkaline cyanide to 2 grams. The reduction of the latter without a corresponding reduction of sulphide is apt to alter somewhat the character of the deposit.

This method was tried out under the most varied conditions, and then applied to the mineral stibnite. Very pure samples of the latter were reduced to powder and 0.5 gram portions digested with 20 cubic centimeters or more of sodium sulphide (1.18 sp. gr.), filtered from the insoluble part, and after the addition of 3 grams of potassium cyanide and one cubic centimeter of sodium hydroxide (10 per cent.), heated to boiling and electrolyzed with $N.D._{100} = 7$ amperes and 3 volts. The results were perfectly satisfactory. The time required to precipitate all the antimony did not exceed twenty-five minutes. See also separation of antimony from arsenic (p. 251).

Antimony has not as yet been satisfactorily determined with the aid of a mercury cathode. The antimony deposits in flocculent masses which do not amalgamate at the cathode.

TELLURIUM.

LITERATURE.—Pellini, *Gaz. chim. ital.*, 34 (I.) 128; Gallo, *Gaz. chim. ital.*, 34 (II.) 404-409; Gallo (*Atti R. Accad. dei Lincei Roma* [5] 13, [1] 713; *Gazz. chim. ital.*, 35, 514 (1905); Schuch t, *Ch. Z.* (1880), 292, 374; *Jahresb.* 1880, p. 174, 1143; Schuch t, *Ch. N.*, 41, 280; *Jahresb.* (1880) 1143, 1144; Schuch t, *Z. f. analyt. Ch.*, 22 (1883) 495; Whitehead, *J. Am. Ch. S.*, 17, 849; *Ch. N.*, 82, 203.

Dissolve the tellurium in nitric acid and evaporate. Heat the residue on a water bath after the addition of ten cubic centimeters of sulphuric acid, introduce 30-40 cubic centimeters of a saturated solution of acid ammonium tartrate to complete solution, dilute with water to 250 cubic centimeters, rotate the anode at the rate of 800 to 900 revolutions

per minute and electrolyze with $N.D._{100} = 0.12$ to 0.09 ampere and 1.8 to 1.2 volts. The electrolyte should be heated to 60° C. Wash the deposit promptly with water free from oxygen, then with alcohol and dry at about 90° C. Rather large quantities of tellurium can be precipitated in this way.

Gallo recommends dissolving distilled tellurium in sulphuric acid, using a sand-blasted dish, then evaporating to the appearance of white fumes. The tellurium dissolves as tellurous acid. When cold add several cubic centimeters of boiled water, free from carbon dioxide, to the white residue, dilute to 150 cubic centimeters with a ten per cent. solution of sodium or potassium pyrophosphate. Heat gradually to 60° C., use a spiral anode, and electrolyze with a current of $N.D._{100} = 0.025$ ampere and 1.8 to 2 volts. About twenty-five milligrams of tellurium will be precipitated per hour.

ARSENIC.

LITERATURE.—L u c k o w, *Z. f. a. Ch.*, **19**, 14; C l a s s e n and v. R e i s s, *Ber.*, **14**, 1622; M o o r e, *Ch. N.*, **53**, 209; V o r t m a n n, *Ber.*, **24**, 2764; S c h u l z e, Inaugural Dissertation, Berlin (1900); T h o r p e, *Jr. Ch. Soc. London*, **83**, 974; S a n d and H a c k f o r d, *Jr. Ch. Soc. London* (1904), 1018; M a i and H u r t, *Ch. Z.*, **29**, Heft 20 (1905), *Z. f. Untersuch. Nahr. Genusen*, **9**, 193 to 199; F r e r i c h s and R o d e n b e r g, *Arch. der Pharmacie*, **243**, 348; T h o r p e, *Ch. N.*, **88**, 7; T r o t m a n, *Jr. Ch. Soc. London*, **23**, 177.

A successful method for the complete deposition of arsenic is not known. The current acting upon the chloride causes complete volatilization of the metal in the form of arsine. Its separation from oxalate solutions is incomplete; nor do the sulpho-salts answer for electrolytic purposes.

From a solution containing 0.2662 gram of arsenious oxide Vortmann obtained 0.18527 gram of metallic arsenic, equivalent to 69.59 per cent. The trioxide contains 75.78 per cent. of arsenic. This precipitation was effected by the amalgam method.

The facts relating to the electrolytic behavior of vanadium (Truchot, *Ann. Chim. Anal.* (1902), 7, 165), tungsten, and osmium are, at the present writing, few in number and will not be introduced here.

2. SEPARATION OF THE METALS.

Electrolysis, to be of value, must furnish the analyst with methods suitable for the complete deposition of metals, and it should, in addition, enable him to separate metallic mixtures. The data given in the preceding pages will serve for this purpose, but, as a special treatment is required in some instances, a brief outline of a series of separations will be indicated.

It will be noticed that the electrolytes vary. The mineral acid and the double cyanide solutions are best adapted for the purpose. The greatest number of separations have been made by means of them. Some of the organic acids, too, answer quite well, as will be seen in the succeeding paragraphs.

COPPER.

Inasmuch as the electrolytic precipitation of copper gives the analyst such an excellent means of determining this metal quantitatively, its separations from other metals are of prime importance. Such separations, so far as they have been carefully worked out in the most essential points, are given in detail in the following paragraphs. It is needless to add that acid solutions mainly are best adapted for these separations.

1. From Aluminium:—

(a) *In nitric acid solution.* Dilution, 200 c.c.; 5 c.c. of nitric acid (sp. gr. 1.30); temperature, 32°; N.D.₁₀₀ = 1 ampere and 3.3 volts; time, 4 hours.

With a rotating anode. Arrange the apparatus as described on p. 78. Dilute the solution to 125 c.c., add 1 c.c. of nitric acid (sp. gr. 1.43) and electrolyze with a current of $N.D._{100} = 3$ amperes and a pressure of 4 to 5 volts. The anode should perform 300 to 400 revolutions per minute. The time allowed the precipitation should not exceed twenty minutes. Copper present 0.2874 gram and aluminium 0.2500 gram. The copper found equaled (a) 0.2873 gram, (b) 0.2874 gram and (c) 0.2874 gram. J. Am. Ch. S., 26, 1284.

(b) *In sulphuric acid solution.* Dilution, 150 c.c.; 3 c.c. of concentrated sulphuric acid; temperature, 59° ; $N.D._{100} = 1$ ampere and 2.5 volts; time, 2 hours.

With a rotating anode. With apparatus arranged as given on p. 78 introduce the solution of salts of the two metals into a dish, dilute to 125 c.c., add 1 c.c. of sulphuric acid (sp. gr. 1.83) and electrolyze with a current of $N.D._{100} = 4$ to 5 amperes and a pressure of 14 to 8 volts. Time, ten minutes. *With a mercury cathode and rotating anode.* This separation was accomplished in the presence of 0.5 cubic centimeter of sulphuric acid (1:1), when the current registered 1 ampere and 4 volts. In four minutes the solution was colorless. The current was allowed to act for ten minutes.

Volume of the solution	= 10 cubic centimeters.
Copper sulphate	⊖ 0.1150 gram copper.
Aluminium sulphate	⊖ 0.1 gram aluminium.
Sulphuric acid (1:1)	= 0.5 cubic centimeter.
Current	= 1-1.6 ampere.
Pressure	= 4-4.5 volts.
Time	= 10 minutes.
<i>Copper found</i>	= 0.1150 gram, 0.1153 gram, 0.1152 gram.

(c) *In phosphoric acid solution.* Dilution, 225 c.c.; 5 c.c. of phosphoric acid (sp. gr. 1.347); temperature, 77° C.; $N.D._{100} = 0.068$ ampere and 2.6 volts; time, 6 hours.

Sixty cubic centimeters of disodium hydrogen phosphate (sp. gr. 1.0338) were present for 0.1239 gram of copper and 0.1000 gram of aluminium. The precipitated copper weighed 0.1240 gram (J. Am. Ch. S., 21, 1002).

In this electrolyte the separation *with the aid of a rotating anode* is also possible when observing these conditions: Dilution 125 c.c., with 10 c.c. of phosphoric acid (sp. gr. 1.085), 50 c.c. of a 10 per cent. solution of disodium hydrogen phosphate, and a current of N.D.₁₀₀ = 5 amperes and 6 volts. Time, 10 minutes. A slight amount of phosphorus, not sufficient to affect the weight materially, was always found in the deposit of copper.

2. From Antimony:—

In tartrate solution. In the presence of one-tenth of a gram of each metal, making certain that the antimony is in its highest state of oxidation, add 8 grams of tartaric acid and 30 c.c. of ammonia (sp. gr. 0.91). Electrolyze at 50° with a current of N.D.₁₀₀ = 0.08–0.10 ampere and 1.8–2 volts. Total dilution 150 c.c. The ordinary temperature. Time, 5 hours (J. Am. Ch. S., 15, 195).

Smith and Wallace (Jr. An. Ch., 7, 189; Z. f. anorg. Ch., 4, 274) have also used this separation with eminent success. They, too, emphasize the necessity of having the antimony in its highest form of oxidation. Several examples will illustrate their method of procedure:—

COPPER PRESENT IN GRAMS.	ANTIMONY IN GRAMS.	DILUTION.	VOL. OF AMMONIA (SP. GR. 0.932).	TARTARIC ACID, IN GRAMS.	VOLTS.	N.D. ₁₀₀ = AMP.	COPPER FOUND.
0.0670	0.1449	175 c.c.	15 c.c.	3-4	1.8	0.1	0.0670
0.1341	0.1449	175 "	15 "	3-4	2.0	0.1	0.1341
0.1341	0.2898	175 "	15 "	3-4	2.0	0.08	0.1344

The deposited metal showed no antimony.

See also Puschin and Trechzinsky, *Ch. Z.*, **28**, 482; also *Elektrochemische Zeitschrift*, **14**, 47.

3. From Arsenic:—

(a) *In ammoniacal solution.* McCay (*Ch. Z.*, **14**, 509) observed that a current conducted through a potassium arsenate solution, made distinctly ammoniacal, had no effect upon the arsenic, while with copper under like conditions the metal was quantitatively precipitated. Upon this behavior he has based a very excellent separation of the two metals. Care should be taken not to introduce too much ammonia water. In this laboratory the method of McCay, with the conditions here presented, has repeatedly given excellent results:—

Add 20 c.c. of ammonium hydroxide (sp. gr. 0.91) and 2.5 grams of ammonium nitrate to the solution containing 0.2121 gram of copper and 0.1540 gram of arsenic; dilute to 125 c.c. with water, heat to 50°–60°, and electrolyze with $N.D._{100} = 0.5$ ampere and 3.5 volts. The copper, precipitated in three hours, weighed 0.2123 and 0.2121 gram. Drossbach (*Ch. Z.*, **16**, 819) and Oettel (*Ch. Z.* (1890), **14**, 509) confirm McCay's experience.

Freudenberg, who adopted the suggestion of Kiliani, of giving more attention to the pressure than to the amperage, succeeded in separating copper and arsenic (latter existing as arsenate) by arranging to have in their solution, 30 c.c. in excess of a 10 per cent. ammonium hydroxide solution and then electrolyzing with a current of 1.9 volts until the liquid became colorless, which usually occurred after from 6–8 hours (*Z. f. ph. Ch.*, **12**, 118).

With a rotating anode (p. 78). Dilute the solution to 125 c.c., add 25 c.c. of ammonium hydroxide (sp. gr. 0.74), and 2.5 grams of ammonium nitrate, then electrolyze with

N.D.₁₀₀ = 5 amperes and 7 volts. Fifteen minutes will suffice to precipitate 0.2742 gram of copper from an equal amount of arsenic. The deposit will be smooth and adherent (J. Am. Ch. S., 26, 1285).

Schmucker separated copper from arsenic with conditions similar to those indicated for copper and antimony in ammoniacal tartrate solution (see above).

(b) *In potassium cyanide solution.* Add the copper solution to that of the alkaline arsenite or arsenate, and then introduce a solution of potassium cyanide until the precipitate first produced is just dissolved; the liquid will then show a slight purple tint. Electrolyze with the following conditions: N.D.₁₀₀ = 0.25–0.26 ampère; volts = 2.4–3.6; dilution, 150 c.c.; time, 3 hours; temperature, 60°.

(c) *In acid solution.* Freudenberg adds 10–20 c.c. of dilute sulphuric acid to the solution of the metals in question and then electrolyzes with a current having a tension of 1.9 volts. The arsenic existed partly as trioxide and partly as pentoxide. The precipitation was made during the night (Z. f. ph. Ch., 12, 117). Copper present, 0.3000 gram; found, 0.2997 gram; arsenic present, 0.3531 gram. The copper was always brilliant in color.

The separation can also be made in nitric acid solution with the same voltage. It is inferior to the first method.

By using the *rotating anode* and following the conditions recommended in the separation of copper from aluminium by the same procedure (p. 183) excellent results may be obtained (J. Am. Ch. S., 26, 1285).

4. **From Barium, Strontium, Calcium, Magnesium, and the Alkali Metals.** The conditions given for the separation of copper from aluminium in nitric acid solution (p. 183) will serve for its separation from these metals.

5. **From Bismuth.** See the separation of bismuth from copper, p. 227.

6. **From Cadmium:—**

(a) *In nitric acid solution.* It was in a solution containing free nitric acid that these two metals were first separated electrolytically (Am. Ch. Jr., 2, 41). The results have been frequently confirmed. An idea of the proper working conditions may be obtained from the following: To a solution in which were present 0.0988 gram of copper and 0.1152 gram of cadmium were added 2 c.c. of nitric acid of sp. gr. 1.43. The total dilution of the liquid equaled 100 c.c. It was heated to 50° and electrolyzed with $N.D._{100} = 0.10$ ampere and 2.5 volts. In 3 hours the copper was completely precipitated. It was bright in color and weighed 0.0988 gram. It contained no cadmium (J. Am. Ch. S., 19, 873; also Jr. An. Ch., 7, 253).

When the copper has been precipitated, washed, dried, and weighed, make the residual liquid alkaline with sodium hydroxide, add sufficient potassium cyanide to redissolve the precipitate, and electrolyze as directed on p. 86.

This separation may be performed in a few minutes with the *rotating anode* by following the conditions prescribed under the separation of copper from aluminium (p. 183) in the same electrolyte (J. Am. Ch. S., 26, 1285).

(b) *In sulphuric acid solution.* From solutions in which there is free sulphuric acid the copper may be electrolytically precipitated, leaving the cadmium. This is evidenced by the following examples: Total dilution, 100 c.c.; 10 c.c. of sulphuric acid, sp. gr. 1.09; 0.1975 gram of copper and 0.1828 gram of cadmium; $N.D._{100} = 0.05-0.07$ ampere and 1.70-1.76 volts; at the ordinary temperature. The precipitate of copper weighed 0.1976 gram (Am. Ch.

Jr., 12, 110). By heating the electrolyte the time can be reduced to 8 hours.

The separation has also been made by strict attention to difference in potential (Freudenberg, Z. f. ph. Ch., 12, 116). Ten to twenty cubic centimeters of dilute sulphuric acid are added to the solution containing the two metals and the liquid is then electrolyzed with a current not exceeding 2 volts. The copper will be deposited very rapidly and be free from cadmium.

COPPER TAKEN.	CADMIUM TAKEN.	COPPER FOUND.
0.2734 gram	0.2560 gram	0.2729 gram
0.4101 gram	0.2958 gram	0.4098 gram
0.3000 gram	0.4437 gram	0.3003 gram

These separations were conducted during the night. Heidenreich (Ber., 29, 1585) met with success in applying Freudenberg's suggestion, but asserts that the tension should not exceed 1.8 volts for $N.D._{100} = 0.07-0.05$ ampere. See also Denso, Z. f. Elektrochem., 9, 469.

(c) *In phosphoric acid solution.* The separation of the two metals in the presence of free phosphoric acid has often been made in this laboratory with satisfaction. Favorable conditions will be found in the example which appears here: Dilution of solution, 125 c.c.; 0.2452 gram of metallic copper and 0.1827 gram of metallic cadmium; 20 c.c. of disodium hydrogen phosphate, sp. gr. 1.0353, and 10 c.c. of phosphoric acid, sp. gr. 1.347; temperature, 60°; $N.D._{100} = 0.07-0.08$ ampere and 2.5 volts; time, 3 hours (Am. Ch. Jr., 12, 329).

7. **From Calcium.** See the separation of copper from barium, p. 187.

8. **From Chromium.** See copper from aluminium, p. 183, for the conditions of separation when the metals are present in nitric or sulphuric acid solution. This statement also

holds true if the *rotating anode* be used in the same electrolytes (J. Am. Ch. S., 26, 1285).

- (a) *In phosphoric acid solution.* Volume of solution (containing 0.1239 gram of metallic copper and 0.1403 gram of metallic chromium as sulphates) 225 c.c., 60 c.c. of disodium hydrogen phosphate (sp. gr. 1.033) and 8 c.c. of phosphoric acid (sp. gr. 1.347); $N.D._{100} = 0.062$ ampere and 2.5 volts; temperature, 65° ; time, 6 hours (J. Am. Ch. S., 21, 1003).

When using the *rotating anode* follow the instructions laid down for the separation of copper from aluminium in this electrolyte (p. 183) (J. Am. Ch. S., 26, 1285). The copper will contain traces of phosphorus.

9. From Cobalt:—

- (a) In the presence of nitric or sulphuric acid the separation of these two metals may be accomplished by observing the conditions given for the separation of copper from aluminium in the presence of the same acids (see p. 183). Dr. Wolcott Gibbs employed mineral acid solutions for this purpose many years ago (Z. f. a. Ch., 3, 334). Most analysts prefer the sulphate solution. Neumann is of this number. He dissolves, for example, 1 gram each of copper sulphate and cobalt sulphate in the requisite volume of water, adds 3 c.c. of concentrated sulphuric acid, dilutes to 150 c.c., and electrolyzes with $N.D._{100} = 1$ ampere at the ordinary temperature. The time required for the complete precipitation of the copper varies from $2\frac{1}{2}$ –3 hours. The filtrate or solution poured off from the deposit of copper need only be mixed with an excess of ammonia water and then be exposed to a stronger current in order to precipitate the cobalt. See Z. f. angw. Ch., 17, 892.

- (b) *In oxalic acid solution.* The double oxalates have also

been used. The method requires a strict adherence to the prescribed voltage (1.1–1.3) to yield a satisfactory result. Classen, with whom the method originated, advises the addition of 6 grams of ammonium oxalate to the solution of the salts and acidulates the liquid with oxalic acid, acetic acid, or tartaric acid. Four hours are required for the precipitation of 0.25 gram of copper (Z. f. Elektrochem., 1, 291, 292; Ber., 27, 2060). Also Puschin and Trechzinsky, Z. f. angew. Chemie, 19, 892.

- (c) *In phosphoric acid solution.* An example will afford an idea of the method of procedure: Total dilution, 225 c.c.; 60 c.c. of sodium hydrogen phosphate (sp. gr. 1.033); 10 c.c. of phosphoric acid (sp. gr. 1.347); N.D.₁₀₀=0.035 ampere and 1.5 volts; temperature, 62°; time, 6 hours. Copper present, 0.1239 gram; cobalt present, 0.1000 gram. Copper found, 0.1243 gram (J. Am. Ch. S., 21, 1003; Am. Ch. Jr., 12, 329; Jr. An. Ch., 5, 133).

In using the *rotating anode to bring about the separation* of copper from cobalt, an electrolyte containing sulphuric or phosphoric acid should not be employed. In a nitric acid electrolyte the separation is all that can be desired. Use the conditions described in the separation of copper from aluminium (p. 183) (J. Am. Ch. S., 26, 1286).

10. **From Gold.** See p. 247.

11. **From Iron:—**

- (a) *In nitric acid solution.* The conditions given for the separation of copper from aluminium (p. 183) will answer here. When much iron is present, difficulties will be encountered. The copper tends to redissolve (Schweder, Berg-Hütt. Z., 36, 5, 11, 31).

- (b) *In sulphuric acid solution.* Experience has demonstrated that the separation of the metals in question is best and most accurately made in the presence of free

sulphuric acid, observing the conditions as described on p. 183 for copper from aluminium. When the copper has been fully precipitated, which usually requires $2\frac{1}{2}$ hours, the residual solution is poured off, the copper is washed, and the liquid reduced to a suitable volume, neutralized with ammonia, and 4-6 grams of ammonium oxalate introduced into the liquid, which is then electrolyzed at 30° - 40° with a current of $N.D._{100} = 1-1.5$ amperes and 3.4-3.8 volts. The iron will be fully precipitated in 3-4 hours (Classen, Neumann).

- (c) *In phosphoric acid solution.* In this laboratory success has attended the use of the phosphates in the presence of free phosphoric acid. Recently the proper conditions as to current density and voltage have been carefully determined. It will be seen from the appended example that the results are most satisfactory: Total dilution, 225 c.c.; disodium hydrogen phosphate, 60 c.c. (sp. gr. 1.0358); 10 c.c. of phosphoric acid (sp. gr. 1.347); temperature, 53° C.; $N.D._{100} = 0.04$ ampere and 2.4 volts; time, 7 hours. Copper present, 0.1239 gram; found, 0.1237 gram (Am. Ch. Jr., 12, 329; Jr. An. Ch., 5, 133; J. Am. Ch. S., 21, 1002).

The use of the *rotating anode* may be resorted to in each of the preceding electrolytes with most satisfactory results, if the conditions mentioned on p. 183 for the separation of copper from aluminium be carefully observed (J. Am. Ch. S., 26, 1286).

- (d) *In ammoniacal solution.* In such a solution Vortmann separates the copper from a large quantity of iron. The liquid containing the two metals is mixed with ammonium sulphate and an excess of ammonia water. The author maintains that the ferric hydroxide, which is of course precipitated, does not interfere with the deposition of the copper. The latter is free from iron. The

current employed in this separation should be $N.D._{100} = 0.1-0.6$ ampere (M. f. Ch., 14, 552).

It is doubtful whether the copper is really free from iron. The opinion presented under the separation of nickel from iron (p. 263) and the experiences there recorded certainly make this recommendation very questionable. Indeed, in this laboratory it was found in separating the copper from iron in chalcopyrite, by this method, that if the precipitation of the former took place in a platinum dish it was invariably contaminated with iron. On the other hand, if the solution of metals was placed in a beaker and a vertical platinum plate was made the cathode, then the copper deposited was free from iron. The ferric hydrate floating about in the platinum dish and in immediate contact with the precipitate is partially reduced to the metallic form.

(e) *In oxalic acid solution.* This procedure is due to Classen (Ber., 27, 2060), who adds to the solution containing both metals in the form of sulphates from 6-8 grams of ammonium oxalate and sufficient oxalic, acetic, or tartaric acid to render the liquid acid. The total dilution is 150 c.c. $N.D._{100} = 1$ ampere; voltage, 2.9-3.4 at $50^{\circ}-60^{\circ}$. Time, 3 hours. It is absolutely necessary to replace the oxalic acid as it is decomposed, otherwise iron will separate upon the copper. The method requires the strictest attention to details, otherwise its results will be far from satisfactory. Indeed, its omission from the last edition of Classen's "Quantitative Electrolysis" would seem to indicate that its author had lost faith in its efficacy.

(f) To a solution of copper sulphate and pure ferrous sulphate add 1.5 gram of pure potassium cyanide and 10 c.c. of ammonia (sp. gr. 0.94), then dilute to 100 c.c., rotate the anode about 400 revolutions per minute and electrolyze with a current of $N.D._{100} = 9$ to 11 amperes

and 10 volts. The copper will be fully precipitated, free from iron, in ten minutes (J. Am. Ch. S., 29, 455).

12. From Lead. The separation of these two metals has great value from the technical standpoint. It is fortunate, therefore, while both separate under the influence of the current in a nitric acid solution, that they are deposited at opposite poles. Very considerable attention has been paid to the conditions which ought to prevail during the deposition. Many writers have contributed their experience on this point, and from them is gathered the following: The liquid electrolyzed should equal 150 c.c. in volume. It should contain 15 c.c. of nitric acid and be heated to about 60° and acted upon with a current of $N.D._{100} = 1-1.5$ amperes and 1.4 volts. In the course of an hour all the lead will have been precipitated upon the anode,—which in this separation should be a dish with roughened surface,—but not all of the copper will have been deposited on the cathode—a smaller, perforated dish. It will be noticed in the course of the decomposition that the lead separates first and the copper more slowly. When the lead is fully precipitated, wash without interrupting the current, proceed further as directed on p. 105, and after placing the liquid and wash water, reduced to 130 c.c., into another weighed dish, make the latter the cathode and suspend in it the smaller dish upon which some copper had been deposited, making it the anode. The solution will give up its copper on passing the current and the metal will be deposited on the larger vessel (the cathode). It may be well to add that the liquid poured from off the lead dioxide will be quite acid, therefore neutralize it with ammonium hydroxide and add 10 c.c. of nitric acid. The electrolysis can then be conducted with $N.D._{100} = 1$ ampere and 2.2–2.5 volts, at the ordinary temperature.

13. From Magnesium. See the separation of copper from barium, etc., p. 187.

Copper may be separated from magnesium in an electrolyte containing nitric, sulphuric or phosphoric acid, with the help of the *rotating anode*, by observing the conditions given under the separation of copper from aluminium, p. 183 (see J. Am. Ch. S., 26, 1286).

14. From Manganese:—

(a) *In sulphuric acid solution.* It should be remembered that from such a solution the manganese will be deposited upon the anode as peroxide (see p. 138); therefore, in the electrolysis let the larger dish, with rough inner surface, be made the anode to receive the manganese. The solution containing the two metals is diluted to 130–150 c.c. with the addition of 10 drops of concentrated sulphuric acid. Let the current be $N.D._{100} = 0.5-1.0$ ampere. The most favorable temperature is $50^{\circ}-60^{\circ}$. The time required is usually 2–3 hours. Experience has taught that too much manganese must not be present. When the deposition is finished, treat the deposit as already described on p. 139. The washing should be performed without interrupting the current.

(b) *In nitric acid solution.* The separation can also be effected in the presence of free nitric acid. If the content of the latter, however, exceeds 3 to 4 per cent., instead of having the manganese precipitated on the anode it remains in solution and a red color appears at the anode due to permanganic acid. In the actual analysis, the solution of the two metals ought to be acidulated with a few cubic centimeters of acid and then electrolyzed at 60° with the same current conditions as given in *a*.

It will be wise here to observe the statement made upon page 139 as to the influence of the strong mineral acids.

Indeed, if this be true, then the preceding separations are worthless and should be discarded, as has been done with the separation in oxalate solutions. In the writer's personal experience the separation in sulphuric acid solution does give satisfactory results. The subject deserves further investigation.

The *rotating anode* may be used in either a sulphuric or nitric acid electrolyte to effect this separation if the conditions under copper from aluminium (p. 183) are observed (J. Am. Ch. S., 26, 1287).

(c) *In phosphoric acid solution.* When free phosphoric acid is present in the solution containing salts of these metals, no question need arise as to the result, for oft-repeated tests, made in this laboratory, have amply demonstrated the accuracy of the procedure. The appended example will illustrate: N.D.₁₀₀ = 0.05 ampere; voltage = 2.5; temperature, 56°; time, 6 hours; dilution, 225 c.c.; copper present, 0.1239 gram; copper found, 0.1236 gram; manganese present, 0.1200 gram; 60 c.c. of disodium hydrogen phosphate (sp. gr. 1.038); 10 c.c. of phosphoric acid (sp. gr. 1.347) (J. Am. Ch. S., 21, 1004, and Am. Ch. Jr., 12, 329).

The copper deposit in this, as well as in the many other trials conducted under practically the same conditions, was deep red in color and very adherent. It contained no manganese. The latter does not even appear at the anode, except as an amethyst color, indicating the formation there of permanganic acid.

15. From Mercury. See the separation of mercury from copper, p. 219.

16. From Molybdenum. Add 1.5 grams of pure potassium cyanide to the solution of the two metals; dilute with water to 150 c.c., heat to 60°, and electrolyze with N.D.₁₀₀ = 0.28

ampere and 4 volts. The copper will be completely precipitated in 5-6 hours.

17. From Nickel:—

(a) *In acid solution.* This separation may be realized by observing the conditions given for the separation of copper from aluminium (p. 183) or those noted under copper from cobalt (p. 190). That is, in nitric or sulphuric acid solution the separation is all that the analyst can ask (Wolcott Gibbs, *Z. f. a. Ch.*, **3**, 334). See also *J. Am. Ch. S.*, **32**, 1472. The separation in oxalate solution, as recommended by Classen (*Z. f. Elektrochem.*, **1**, 291, 292), must be executed with conditions analogous to those indicated for copper from cobalt, *b* (p. 190). See also *Z. f. Elektrochem.*, **9**, 469.

(b) *In phosphoric acid solution.* The writer has found that in the presence of free phosphoric acid this separation can be made with ease and with confidence of securing a favorable result: copper present, 0.1239 gram; copper found, 0.1241 gram; nickel present, 0.1366 gram; 60 c.c. of disodium hydrogen phosphate, sp. gr. 1.033; 10 c.c. of phosphoric acid, sp. gr. 1.347; total dilution, 225 c.c.; $N.D._{100} = 0.035$ ampere; tension = 1.5 volts; time, 6 hours; temperature, 62° C. (*J. Am. Ch. S.*, **21**, 1003). For the conditions when iron, cobalt, zinc, and copper are present together in phosphoric acid solution, see *J. Am. Ch. S.*, **21**, 1004.

To the solution containing 0.2500 gram of each metal add 0.25 cubic centimeter of concentrated nitric acid and three grams of ammonium nitrate. Electrolyze with a current of $N.D._{100} = 4$ amperes and a pressure of 5 volts. In fifteen minutes the separation will be complete. The speed of rotation of the anode should be about 600 revolutions per minute.

To show how helpful this separation may be an analysis of a nickel coin will be here given:

Dissolve the coin (4.925 grams in weight) in 20 cubic centimeters of concentrated nitric acid diluted with an equal volume of water. Exactly neutralize with ammonium hydroxide, transfer to a 250 cubic centimeter measuring flask and fill this to the mark with water. Transfer 25 cubic centimeters of this liquid to a weighed platinum dish, and add three grams of ammonium sulphate, then dilute with water to 125 cubic centimeters, heat almost to boiling and electrolyze with a current of $N.D._{100} = 5$ amperes and a pressure of 5.5 volts for twenty minutes. (The precipitated copper in this particular analysis weighed 0.3691 gram = 74.95 per cent. of the coin.) Precipitate the nickel from the solution with sodium hydroxide and bromine water, filter and wash. Dissolve the precipitate in 2 cubic centimeters of concentrated sulphuric acid diluted with water, add 30 cubic centimeters of concentrated ammonium hydroxide, dilute to 125 cubic centimeters, heat and electrolyze with a current of $N.D._{100} = 6$ amperes and a pressure of 5 volts. (In twenty minutes 0.1217 gram, corresponding to 24.71 per cent. of nickel, was precipitated.) The solution from the nickel deposit should be filtered to get the iron—in this particular case it weighed 0.0026 gram, equivalent to 0.35 per cent. of metallic iron.

Two and one-half hours will suffice for the complete analysis (J. Am. Ch. S., 25, 906). Thiel, Z. f. Elektroch., 14, 203.

18. **From Palladium.** See the following separation:
19. **From Platinum.** Add 1.5 grams of pure potassium cyanide and 5 grams of ammonium carbonate to the solution of the two metals, dilute with water to 125 c.c., heat to 70° ,

and electrolyze with $N.D._{100}=0.2$ ampere and 2–2.5 volts. The copper will be precipitated in 6 hours.

In using the *rotating anode* add to the solution of the two metals, 3 grams of potassium cyanide and 10 to 20 c.c. of ammonia. Electrolyze with a current of $N.D._{100}=3$ amperes and 5 volts. J. Am. Ch. S., **29**, 471.

20. From Potassium. See copper from barium, etc. (p. 187).

21. From Selenium:—

(a) *In cyanide solution.* To the solution containing 0.0745 gram of copper and 0.2500 gram of sodium selenate add 1 gram of potassium cyanide, dilute to 150 c.c., heat to 60° C., and electrolyze with $N.D._{100}=0.2$ ampere and 4 volts. The precipitation will be finished in five hours.

(b) *In nitric acid solution.* To a solution containing the quantities of metal as in (a) add 1 c.c. of nitric acid (sp. gr. 1.43), dilute to 150 c.c. and electrolyze at 65° C., with a current of $N.D._{100}=0.05$ to 0.08 ampere and 2 to 2.5 volts.

(c) *In sulphuric acid solution.* Add one cubic centimeter of concentrated sulphuric acid to the solution of the metals and electrolyze with $N.D._{100}=0.05$ to 0.10 ampere and 2.25 volts at 65° C. The separation will be complete in five hours.

22. From Sodium. See copper from barium, p. 187.

23. From Strontium. See copper from barium, p. 187.

24. From Silver. See silver from copper, p. 240. Classen proposed to precipitate the two metals with ammonium oxalate, silver oxalate being insoluble in an excess of the precipitant, while the copper salt was soluble. The former was to be filtered off, dissolved in potassium cyanide, and electrolyzed, while the filtrate containing the copper was to be subjected to a separate electrolysis. This is really

not an electrolytic separation, as was shown by others (J. Am. Ch. S., 16, 420). Further, the copper deposits were invariably found to contain silver, so that it is best not to follow this procedure.

25. From Tellurium:—

(a) *In nitric acid solution.* For several years, at intervals, experiments have been made in this laboratory by D. L. Wallace, upon the electrolytic separation of these metals. The results have been uniformly good with the following conditions: Copper, in grams, 0.1543; tellurium, in grams, 0.1101; dilution, 100 c.c.; 0.5 c.c. nitric acid (sp. gr. 1.42); N.D.₁₀₀=0.10 ampere and 2.06 volts; temperature, 66°–70°; time, 5 hours. Copper found: (a) 0.1541 gram; (b) 0.1546 gram; (c) 0.1543 gram; (d) 0.1542 gram.

(b) *In sulphuric acid solution.* Add one cubic centimeter of concentrated sulphuric acid to the solution of the metals, dilute to 150 c.c., heat to 65° C., and electrolyze with N.D.₁₀₀=0.05 to 0.1 ampere and 2 to 2.25 volts. Six hours will suffice for the precipitation of the copper (J. Am. Ch. S., 25, 895).

26. From Thallium. No attempt has been made to effect this separation.

27. From Tin. Schmucker demonstrated (J. Am. Ch. S., 15, 195) that, having tin in its highest oxidation form, it is possible to precipitate and separate copper from it by adding to the solution 8 grams of tartaric acid and 30 c.c. of ammonia water (sp. gr. 0.91), then electrolyzing at 50° C. with N.D.₁₀₀=0.04 ampere and 1.8 volts. If a tenth of a gram of each metal be present, the copper will be precipitated in 5 hours. The total dilution was 175 c.c.

As observed in preceding paragraphs, this method was utilized by Schmucker in the separation of copper from arsenic and copper from antimony. The same author also

separated copper from a mixture of antimony, arsenic, and tin, using the conditions as described above.

Or, when antimony, arsenic, and tin are associated with copper, treat the four sulphides with sodium sulphide. The resulting alkaline sulphide solution can then be employed for the separation of the first three (p. 251), while the insoluble copper sulphide may be dissolved and treated as described on p. 75.

Alloys containing equal amounts of copper and tin together with 5 per cent. to 10 per cent. of antimony should be dissolved in 5 c.c. of 50 per cent. tartaric acid and 4 c.c. of nitric acid of 1.4 specific gravity. The liquid should be cooled at the beginning. Water should be added to increase the volume to 40 c.c. A gauze electrode of 5 cm. height and 10 cm. circumference is placed in the solution and the electrolysis made with a current of 1.5 amperes. After three-quarters of an hour enough 1 per cent. nitric acid is introduced to make the electrolyte cover the exposed parts of the gauze and the electrolysis is continued for 15 minutes. Weigh the precipitated copper and test it for tin. To get the last trace of copper in the siphonate add 1 c.c. of 50 per cent. tartaric acid, neutralize with caustic potash and precipitate with the exact amount of alkaline sulphide. Neutralize the filtrate with sulphuric acid and add sufficient oxalic acid to prevent the separation of tin oxide, then precipitate the antimony with hydrogen sulphide and subsequently the tin. (Mitt. a. d. Königl. Material Prüfungsamt in Lichtfeld, 27, 470.) This is at best an unsatisfactory procedure. It is therefore refreshing to follow the course recommended by H. J. S. Sand (Proc. Chem. Soc., 25, 1909), in which a graded potential is employed. The separation of copper from antimony and from bismuth is also possible in this way. (Z. f. Elektroch., 15, 591, 1909).

A. Fischer (*Z. f. Elektroch.* **15**, 594) proceeds as follows in the analysis of a bronze: 0.5 to 0.6 gram of the finely divided material is covered with a solution of 6 grams of tartaric acid and 1 gram of monochloroacetic acid and this gently heated, during which time from 2 to 2.5 c.c. of concentrated nitric acid are gradually introduced. The solution is then made alkaline with sodium hydroxide, heated to 90° and acidulated with 2 grams of tartaric acid. A current of 2 amperes and a voltage of 0.55 to 0.75 is applied. The anode performs 800 to 1000 revolutions per minute. The copper is completely precipitated in from 20 to 25 minutes. The liquid, after removal of the cathode carrying the current, is reduced in volume to 120 c.c., then made ammoniacal with ammonium hydroxide, and 2 to 3 grams of sodium sulphite are introduced. The solution is then heated for about 5 minutes to gentle boiling. The precipitate consisting of the sulphides of lead, iron and zinc is then removed and afterward dissolved in nitric acid. The lead, zinc, and iron are separated in the usual way and the filtrate from their sulphides is then applied in the precipitation of the tin. This is performed with a sulpho-salt solution.

Hollard and Bertiaux (*B. S. Chim., Paris*, **31**, 102) separate these metals in this way: the solution of the sulphate is neutralized with ammonium hydroxide, then there are added 5 grams of ammonium sulphate, 20-30 c.c. of ammonium hydrate of specific gravity 0.91 and 0.5 to 1 gram of crystallized sodium sulphite. The liquid is diluted to 250 c.c., warmed to 90° , and electrolyzed with a current of 0.1 ampere, using a gauze cathode. Foerster and Treadwell (*Z. f. Elektroch.*, **14**, 89) show that the nickel obtained in this way always contains sulphur. The separation of the metals is satisfactory, but in an accurate determination of the nickel, the latter should be redissolved and precipitated in the usual way.

28. From Tungsten. The conditions given for the separation of copper from molybdenum (p. 196) may be used for this separation.

29. From Uranium:—

(a) *In nitric acid solution.* Add 0.5 c.c. of concentrated nitric acid to the solution, dilute to 150 c.c., heat to 60°, and electrolyze with $N.D._{100} = 0.14 - 0.27$ ampere and 2-2.4 volts. The copper will be precipitated in 3 hours.

(b) *In sulphuric acid solution.* The solution of these metals should be mixed with 2 c.c. of concentrated sulphuric acid, diluted to 150 c.c. with water, heated to 50°-60°, and electrolyzed with $N.D._{100} = 0.16$ ampere and 2 volts. The precipitation will be complete in 4 hours.

The separation of copper from uranium may be readily carried out with the help of a *rotating anode* by observing the conditions given for the separation of copper from aluminium in the same electrolytes (p. 183) (J. Am. Ch. S., 26, 1287).

30. From Vanadium. A method of separation is lacking.

31. From Zinc:—

(a) *In nitric acid solution.* The conditions mentioned under *a* in copper from aluminium (p. 183), and under copper from cobalt (p. 190) and nickel (p. 197), will answer here in getting a satisfactory separation. The solution must be kept acid during the decomposition. To this may be added, that to a solution containing 0.1341 gram of copper and equal amounts of zinc, cobalt, and nickel, 5 c.c. of nitric acid were added, the liquid was diluted to 200 c.c., and electrolyzed with 0.04 ampere, when 0.1339 gram of copper was obtained.

In using the *rotating anode* in conducting this separation add to the solution of the metals 3 grams of am-

monium nitrate and 0.25 c.c. of concentrated nitric acid, then electrolyze with a current of $N.D._{100} = 5$ amperes and 9 volts. Time, 15 minutes.

(b) *In sulphuric acid solution.* The conditions are analogous to those employed for the separation of copper from aluminium (p. 183), cobalt (p. 190), and nickel (p. 197).

In this electrolyte also the separation is greatly accelerated by the use of the *rotating anode*. Dilute the solution to 125 c.c., add 1 c.c. of sulphuric acid of sp. gravity 1.83 and electrolyze with $N.D._{100} = 3$ to 5 amperes and 5 volts. Time, 10 minutes.

(c) *In oxalate solution.* This method (Ber. 17, 2467) is no longer recommended. Only the most careful observance of the conditions given will yield anything like a satisfactory result.

(d) *In phosphoric acid solution* (Am. Ch. Jr., 12, 329; Jr. An. Ch., 5, 133). The early suggestions that these metals be precipitated as phosphates and the latter be then dissolved in phosphoric acid and the resulting solution be electrolyzed were not favorably received. Here, in this laboratory, where the separation had been repeatedly performed, the method gave satisfaction. To extend its application the most favorable conditions have been worked out and repeated. They are given in the example which follows:

To the solution of the sulphates, containing 0.1239 gram of copper and a like quantity of zinc, were added 60 c.c. of disodium hydrogen phosphate (sp. gr. 1.033) and 10 c.c. of phosphoric acid (sp. gr. 1.347). It was diluted to 225 c.c., heated to 60° , and electrolyzed with $N.D._{100} = 0.035$ ampere and 2.5 volts, for 5 hours, when 0.1244 gram of copper was obtained, free from zinc.

By following the conditions given in the separation of copper from aluminium (p. 183) in this electrolyte,

a *rotating anode* will prove most helpful. Traces of phosphorus will appear in the copper deposits.

Another interesting* separation, properly belonging here, is that of copper from a mixture of iron, cobalt, and zinc. A solution diluted to 225 c.c. contained:—

0.1239 gram of copper
 0.1007 gram of cobalt
 0.1000 gram of iron
 0.1200 gram of zinc
 30 c.c. of Na_2HPO_4 (sp. gr. 1.0358)
 15 c.c. of H_3PO_4 (sp. gr. 1.347)

It was electrolyzed at 57° with a current of $\text{N.D.}_{100} = 0.04-0.05$ ampere and 2.3 volts. In six hours the copper was fully precipitated. It weighed 0.1240 gram and contained none of the other metals (J. Am. Ch. S., 21, 1003, 1004).

CADMIUM.

The ordinary gravimetric methods for the determination of this metal are such that they can frequently be replaced with advantage by the electrolytic process. The same is true when it comes to the separation of cadmium from the metals usually associated with it, as well as those with which it occasionally occurs. The writer prefers the electrolytic course whenever it is available. To what extent the various suggestions offered for the electrolytic determination of the metal can be applied in separations may be gathered from the following paragraphs:—

1. From Aluminium:—

(a) *In sulphuric acid solution.* In this separation it is only necessary to add to the solution of the salts of the metals 3 c.c. of sulphuric acid, of specific gravity 1.09, dilute to 125 c.c. with water, heat to 65° , and electrolyze with $\text{N.D.}_{100} = 0.078$ ampere and 2.61 volts. The

cadmium will be deposited in the course of from 4-4½ hours. It should be washed without interrupting the current. In one case 0.1111 gram of Cd instead of 0.1105 was found; in another, 0.1181 instead of 0.1188 gram; and in a third, 0.1604 instead of 0.1599 gram.

To demonstrate the advantage in using a *rotating anode* in making this separation an example in actual experimentation may be here introduced:

To a solution containing 0.2727 gram of cadmium and 0.2500 gram of aluminium add 1 c.c. of sulphuric acid (sp. gr. 1.83), dilute to 125 c.c. with water and electrolyze with a current of $N.D._{100} = 5$ amperes and 5 volts. Time, ten minutes. The deposits are perfectly adherent (J. Am. Ch. S., 26, 1288). Or, by using a mercury cathode and rotating anode with a current of 3 amperes and 7 volts, total volume of the solution being 10 c.c., this separation may be made in twenty minutes.

(b) *In phosphoric acid solution.* Add an excess of disodium hydrogen phosphate (sp. gr. 1.0358) to the solution of the metals and then sufficient phosphoric acid (sp. gr. 1.347) to leave about 1.5 c.c. of the latter in excess. Dilute with water to 100 c.c., heat to 50°, and electrolyze with $N.D._{100} = 0.06$ ampere and 3 volts. Time, 7 hours. See p. 86 for further details (J. Am. Ch. S., 20, 279; Am. Ch. Jr., 12, 329; 13, 206).

When using the *rotating anode* dilute the solution of the metal salts to 125 c.c. after adding 10 c.c. of phosphoric acid, and 50 c.c. of a 10 per cent. solution of disodium hydrogen phosphate solution and electrolyze with a current of $N.D._{100} = 5$ amperes and 7 volts for 10 minutes (J. Am. Ch. S., 16, 1288).

2. **From Antimony.** Schmucker (J. Am. Ch., S., 15, 195) used for this purpose the method described on p. 185 for

the separation of copper from antimony, observing the same conditions. The results were perfectly satisfactory. In washing the cadmium deposit water alone was used. The deposition was made during the night, but by heating the electrolyte the time factor can be much reduced.

3. From Arsenic:—

(a) *In ammoniacal tartrate solution.* Proceed precisely as directed on p. 186 in the separation of copper from arsenic (J. Am. Ch. S., 15, 195).

(b) *In alkaline cyanide solution.* After converting the arsenic into its highest state of oxidation, add from 2 to 3 grams of potassium cyanide to the solution containing the metals and electrolyze with a pressure not exceeding 2.6 volts (Am. Ch. Jr., 12, 428; Z. f. ph. Ch., 12, 122).

4. From Barium, Strontium, Calcium, Magnesium, and the Alkali Metals. See Holmes and Dover, J. Am. Ch. S., 32, 1251.

5. From Beryllium. There is no record of this separation.

6. From Bismuth. See separation of bismuth from cadmium, p. 225.

7. From Chromium. The conditions given for the separation of cadmium from aluminium will answer equally well in this case; also when applying a *rotating anode* in a phosphoric acid electrolyte (J. Am. Ch. S., 26, 1288).

In the presence of 3 cubic centimeters of concentrated sulphuric acid, using the *mercury cathode and rotating anode*, this separation is easily made with a current of 2 to 3 amperes and 3.5 to 4 volts. Time, 25 minutes.

8. From Cobalt:—

(a) *In sulphuric acid solution.* Use the conditions prescribed for the separation of cadmium from aluminium (p. 183). It may be well to add that the addition of

ammonium sulphate to the solution is advantageous. The voltage should not exceed 2.8–2.9.

(b) *In alkaline cyanide solution.* Add 4–5 grams of pure potassium cyanide to the solution of the metals, dilute to 200 c.c., and electrolyze with $N.D._{100} = 0.3$ ampere and 2.6 volts (Am. Ch. Jr., 12, 104; Z. f. ph. Ch., 12, 116). See also J. Am. Ch. S., 27, 1286.

9. **From Copper.** See also copper from cadmium, pp. 188, 189. In addition to the methods used in separating these metals, in which the copper is precipitated, we may add the following: Introduce 5 to 6 grams of pure potassium cyanide into the solution of the metals for every 0.2–0.4 gram of cadmium and copper. Dilute the solution to 200 c.c. and electrolyze with a current of $N.D._{100} = 0.02-0.04$ ampere and 2.6–2.7 volts. The cadmium will be deposited; the copper will remain dissolved (Jr. An. Ch., 3, 385; Z. f. ph. Ch., 12, 122). Rimbach (Z. f. a. Ch., 37, 288) has tried this separation with marked success in the analysis of aluminium-cadmium-tin alloys containing copper as impurity. In case the nitrate of cadmium is used it will be necessary to increase the current to $N.D._{100} = 0.4$ ampere.

10. **From Gold.** This separation is not recorded. It is probable that it can be executed in a hot alkaline cyanide solution.

11. **From Iron:—**

(a) *In sulphuric acid solution.* Follow the directions given in a under cadmium from aluminium, p. 205. It may be observed that this is the procedure used, too, in separating cadmium from chromium. See the separation of cadmium from aluminium (p. 206) for the conditions to be used when applying a *rotating anode* (J. Am. Ch. S., 26, 1288).

(b) *In phosphoric acid solution.* Again the conditions noticed in *b* under cadmium from aluminium (p. 206) will prove to be very satisfactory in this particular case (J. Am. Ch. S., **26**, 1289).

(c) *In potassium cyanide solution.* Dissolve a mixture of cadmium and ferrous sulphates in 100 c.c. of water, previously acidulated with a few drops of dilute sulphuric acid, introduce 2 to 3 grams of pure potassium cyanide, and heat gently until perfect solution ensues. If considerable time elapses before the liquid becomes yellow in color, add a few drops of caustic potash. Dilute the liquid to 200 c.c. and electrolyze the cold solution with a current of $N.D._{100} = 0.05-0.1$ ampere. The deposit of cadmium will be very satisfactory (W. Stortenbeker, Z. f. Elektrochem., **4**, 409).

It is possible, by using the *rotating anode*, to perform this separation in twenty minutes by electrolyzing the solution of mixed salts, after the addition of 12 grams of potassium cyanide and 2 grams of sodium hydroxide, with a current of $N.D._{100} = 5$ amperes and a pressure of 5 volts. It is well to use a quarter of a gram of each metal (J. Am. Ch. S., **27**, 1285).

12. From Lead. See lead from cadmium, p. 234.

13. From Magnesium. See cadmium from barium, etc., p. 207. In this connection it may be stated that Rim-bach (Z. f. a. Ch., **37**, 289) effected this separation in a potassium cyanide solution. The precaution is made that not too much magnesia be present, ammonium chloride also being added to the solution to hold up the magnesia. The current strength best adapted for this separation proved to be $N.D._{100} = 0.02-0.05$ ampere. The time was 14 hours.

In a formic acid solution. To the solution of the salts of the two metals add 0.2 gram of sodium carbonate and

12 c.c. of formic acid of sp. gr. 1.06, then electrolyze with a current of $N.D._{100} = 5$ amperes and 6 volts. The anode should perform about 600 revolutions per minute. Ten minutes will answer for the full precipitation of the cadmium (J. Am. Ch. S., 27, 1285).

In electrolytes of sulphuric and phosphoric acid the conditions applicable here, are found under cadmium from aluminium, pp. 205, 206.

14. From Manganese:—

(a) *In sulphuric acid solution.* As manganese separates readily from a sulphate solution in the presence of a slight excess of sulphuric acid, and then, too, upon the anode (p. 138), it is only necessary to add from 2 to 3 c.c. of sulphuric acid (sp. gr. 1.09) to the solution of the metals, dilute to 125 c.c., and electrolyze with the current and voltage given under cadmium from aluminium, *a*. As the manganese is precipitated upon the anode as dioxide, make the larger dish the receiving vessel for it; further, let its inner surface be roughened. The cadmium is deposited upon the cathode. The method has been used in this laboratory with success.

(b) *In phosphoric acid solution.* An idea of the accuracy of the method can be best obtained from an actual example. Twenty cubic centimeters of disodium hydrogen phosphate (sp. gr. 1.0358) and 3 c.c. of phosphoric acid (sp. gr. 1.347) were added to a solution containing 0.2399 gram of cadmium and 0.1000 gram of manganese and the liquid then diluted with water to 150 c.c. and electrolyzed at the ordinary temperature with a current of 1 ampere. In 12 hours 0.2394 gram of cadmium was precipitated. There was not the slightest deposition of manganese at the anode. The cadmium deposit was crystalline in appearance. It was washed with hot water. Before

the final interruption, the current ought to be increased and allowed to act for an hour. The acid liquid should be removed with a siphon before disconnecting (Am. Ch. Jr., 13, 206).

In using the *rotating anode* as an aid in this separation, according to (a) and (b) follow the conditions given under the separation of cadmium from aluminium, p. 206 (J. Am. Ch. S., 26, 1289).

15. **From Mercury.** See mercury from cadmium, p. 218.

16. **From Molybdenum.** The alkaline cyanide solution is well adapted for this purpose. Add from 1.5 to 3 grams of pure potassium cyanide, dilute to 200 c.c., and electrolyze at 40° C., with $N.D._{100} = 0.03-0.04$ ampere and 2.25-3.0 volts. The conditions are practically those used in the separation of cadmium from arsenic (Am. Ch. Jr., 12, 428).

17. **From Nickel:—**

(a) *In sulphuric acid solution.* To the solution of salts of the two metals add 2 to 3 c.c. of sulphuric acid, sp. gr. 1.09, also ammonium sulphate, and electrolyze with the current density and voltage mentioned in the separation of cadmium from aluminium, a, p. 205.

The conditions favorable to the use of the *rotating anode* in this separation are analogous to those outlined under the separation of cadmium from aluminium, p. 206.

(b) *In phosphoric acid solution.* 0.1827 gram of cadmium and 0.1500 gram of nickel (both as sulphates) were precipitated by 40 c.c. of disodium hydrogen phosphate, dissolved in 3 c.c. of phosphoric acid (sp. gr. 1.347), diluted to 125 c.c., and electrolyzed at the ordinary temperature with $N.D._{100} = 0.035$ ampere and 2.5-3.0 volts. The precipitated cadmium weighed 0.1820 gram. It was washed and treated as directed upon p. 86.

(c) *In alkaline cyanide solution.* The solution containing the double cyanides of the two metals is well suited for this separation, but it is absolutely necessary to have a little free sodium hydroxide present. The conditions would be then about as follows: Add to the solution containing 0.1723 gram of cadmium, and 0.1600 gram of nickel, 2 grams of potassium or sodium hydroxide and 3 grams of potassium cyanide. Dilute to 175 c.c. and electrolyze at 40° with $N.D._{100} = 0.03-0.04$ ampere and 2.25-3.0 volts (Am. Ch. Jr., 12, 104; Freudenberg, Z. f. ph. Ch., 12, 122).

18. **From Osmium.** The only recorded separation of these two metals was made in a solution of potassium cyanide. The quantity of cyanide was 1.5 grams for 0.3 gram of the combined metals. The dilution of the solution equaled 170 c.c.; it was electrolyzed with a current of $N.D._{100} = 0.26$ ampere and 3-4 volts. Time, 10 hours; temperature, 25° (Jr. An. Ch., 6, 87).

An electrolytic separation of cadmium from platinum and palladium is not known (Am. Ch. Jr., 12, 428; 13, 417).

19. **From Selenium.** This separation has not been made.

20. **From Silver.** See p. 239, for silver from cadmium.

21. **From Sodium.** See the separation of cadmium from barium, etc., p. 207.

22. **From Strontium.** See the separation of cadmium from barium, etc., p. 207.

23. **From Tellurium.** There is no known electrolytic separation.

24. **From Tin.** They have not been separated electrolytically.

- 25. From Tungsten.** The conditions detailed in the separation of cadmium from arsenic (p. 207) and under cadmium from molybdenum (p. 211) in cyanide solution will answer here.
- 26. From Uranium.** The current has not been used in their separation.
- 27. From Vanadium.** They have not been separated in the electrolytic way.
- 28. From Zinc.** As these two metals are so frequently found together, both in natural and in artificial products, it is not surprising that electrolytic methods have been sought to effect their separation in such a manner as to leave no doubt in the mind of the analyst. They should be and indeed are preferable to the ordinary gravimetric procedures.

The first method proposed and published was that by Yver (B. s. Ch. Paris, 34, 18). It is based upon the fact that cadmium separates well—

(a) *In acetate solution.* Convert the metals into acetates by the addition of 2 to 3 grams of sodium acetate to their solution, followed by several drops of free acetic acid. Dilute the liquid to 100 c.c. and warm to 70° C. Electrolyze with $N.D._{100} = 0.10$ ampere and 2.2 volts. Time, 3–4 hours. The cadmium (0.2 gram) will be precipitated in a crystalline form and free from zinc (Am. Ch. Jr., 8, 210).

The zinc in the liquid from the cadmium deposit may then be precipitated by the method of Richè (p. 118).

Mention may be here made of the fact that Smith and Knerr (Am. Ch. Jr., 8, 210) electrolyzed a solution of cadmium and zinc to which 3–4 grams of sodium tartrate and tartaric acid had been added, with a current of $N.D._{100} = 0.3-0.4$ ampere and 2.25–3 volts. The temperature of the solution was 60°.

(b) *In oxalic acid solution.* Eliasberg (Z. f. a. Ch., 24, 550) proposed this method, second in point of time, and recommended the following procedure: Dissolve the metallic oxides in hydrochloric acid, evaporate their solution to dryness, take up the residue in water, add to the liquid 8 grams of potassium oxalate ($K_2C_2O_4$) and 2 grams of ammonium oxalate ($(NH_4)_2C_2O_4$), dilute to 120 c.c., heat to $80^\circ-85^\circ$, and electrolyze with $N.D._{100}=0.01-0.02$ ampere and 3 volts. The cadmium will be precipitated free from zinc. See also Waller, Z. f. Elektrochem., 4, 241-247. From 6 to 7 hours are required for the deposition of 0.2 gram of cadmium.

(c) *In sulphuric acid solution.* To the liquid containing the salts of the two metals add 3 to 4 c.c. of a concentrated ammonium sulphate solution and follow with 2 to 3 c.c. of dilute sulphuric acid. Dilute to 100 c.c. and electrolyze with $N.D._{100}=0.08$ ampere and 2.8-2.9 volts (Neumann's *Elektrolyse*, p. 189). See Denso, Z. f. Elektrochem., 9, 469.

In the electro-chemical laboratory of the University of Munich the separation of cadmium from zinc is in a certain sense a combination of *c* and *a*. For example, sodium hydroxide is added to the sulphates of the metals until a permanent precipitate is formed; this is then dissolved in as little sulphuric acid as possible, the solution is diluted to 70 c.c. and the cadmium precipitated by a current of $N.D._{100}=0.07$ ampere. When the greater portion of this metal has been thrown out of the solution, the free sulphuric acid is neutralized with sodium hydroxide and 2 to 3 grams of sodium acetate are introduced into the liquid, which is heated to 45° and electrolyzed with a current of $N.D._{100}=0.03$ ampere and 3.6 volts.

(d) *In phosphoric acid solution.* Total dilution, 125 c.c.;

cadmium, 0.1827 gram; zinc, 0.1500 gram; disodium hydrogen phosphate (sp. gr. 1.038), 40 c.c.; phosphoric acid (sp. gr. 1.347), 3 c.c.; $N.D._{100} = 0.035$ ampere; $V = 2.5-3.0$. Cadmium found, 0.1820 gram. The ordinary temperature. Time, 10 hours (Am. Ch. Jr., 12, 329).

(e) *In potassium cyanide solution.* This separation originated in this laboratory (Am. Ch. Jr., 11, 352). Example: 0.2426 gram of cadmium as sulphate, 0.2000 gram of zinc as sulphate; 4.5 grams of potassium cyanide; total dilution, 200 c.c. Ordinary temperature. $N.D._{100} = 0.03$ ampere; volts = 2.8-3.2. 0.2429 gram of cadmium found.

In the filtrate the zinc may be precipitated by increasing the current. Freudenberg used this method with success, applying a current corresponding to an electromotive force of 2.6-2.7 volts.

See also M. E. Holmes, Jr. Am. Ch. S., 30, 1865-1874.

MERCURY.

Experience has proved that this metal is most accurately determined, and most satisfactorily separated from the metals usually found with it by the use of electrolytic methods which in this instance are preferable in every particular to the ordinary gravimetric courses; hence all the known separations in the electrolytic way will be given, in the paragraphs which follow, with such detail that no doubt need remain as to the final results.

While mercury is very quickly determined with the help of the *rotating anode*, it is almost impossible to separate it from other metals, owing to the readiness with which it forms amalgams. It was, however, separated in a beautiful mirror-like form from aluminium and magnesium.

1. From Aluminium:—

(a) *In nitric acid solution* (p. 183). Add 3 c.c. of concen-

trated nitric acid to the solution of the two salts, dilute to 125 c.c.; heat to 70° C., and electrolyze with $N.D._{100} = 0.06$ ampere and 2 volts. Time, 2 hours. The solution in the dish must be siphoned off before the interruption of the current.

(b) *In sulphuric acid solution* (p. 184). Add 1 c.c. of sulphuric acid to the solution of the salts; dilute to 125 c.c., heat to 65° and electrolyze with $N.D._{100} = 0.4-0.6$ ampere and 3.5 volts. The mercury (0.1500 gram) will be precipitated in an hour. Wash it with cold water and proceed as directed on p. 95.

2. **From Antimony.** Add to the solution, containing about equal amounts of the two metals, 5 grams of tartaric acid and 15-20 c.c. of ammonia water (10 per cent.); dilute to 175 c.c., and electrolyze with $N.D._{100} = 0.015-0.085$ ampere and 2.2-3.5 volts. The temperature should be 50°. About 6 hours will be required for the precipitation (J. Am. Ch. S., 15, 205). The antimony must exist in solution as an antimonious compound. The method was first worked out by Schmucker (*loc. cit.*) and was later successfully confirmed by Freudenberg in his study of the differences in potential (Z. f. ph. Ch., 12, 112), when he employed an electromotive force of 1.6-1.7 volts. Mercury used, 0.2362 gram; mercury found, 0.2356 gram; antimony present, 0.2600 gram.

The liquid from the deposit of mercury, after acidulation, may be precipitated with hydrogen sulphide and the resulting sulphide be dissolved in sodium sulphide and treated as described on p. 174 for the determination of the antimony.

3. **From Arsenic:—**

(a) *In nitric acid solution.* The solution of the metals should contain a few cubic centimeters of free nitric acid and then be acted upon with an electromotive

force of 1.7–1.8 volts: Mercury taken, 0.2380 gram; mercury found, 0.2380 gram; arsenic present, 0.2516 gram (Freudenberg, *Z. f. ph. Ch.*, 12, 111).

- (b) *In potassium cyanide solution.* Add 3 grams of pure potassium cyanide to the liquid containing 0.5 gram of combined metals, dilute to 200 c.c., and electrolyze with $N.D._{100} = 0.015$ ampere and 2.2–3.5 volts for 5 hours at 65° (*Am. Ch. Jr.*, 12, 428). It is immaterial whether the arsenic is present as an arsenite or arsenate.
- (c) *In alkaline sulphide solution* (p. 96). An example will best illustrate the method: To the solution of mercury add 25 c.c. of sodium sulphide (sp. gr. 1.19), dilute with water to 125 c.c., heat to 70° C., and electrolyze with a current of $N.D._{100} = 0.11$ ampere and 2.5 volts. The time for precipitation is usually 5 hours. See *Jr. Fr. Ins.*, 1891.

4. **From Barium, Strontium, Calcium, Magnesium, and the Alkali Metals.** Use method *a* under mercury from aluminium (p. 215) for this purpose.
5. **From Bismuth.** Freudenberg (*Z. f. ph. Ch.*, 12, 111), by adherence to the idea of the differences in potential, gave results which would indicate a complete separation; a few cubic centimeters of nitric acid, of sp. gr. 1.2, and 2–4 grams of ammonium nitrate are added to the nitrate solution of the two metals and the electrolysis conducted with a potential of 1.3 volts. Mercury used, 0.2380 gram; mercury found, 0.2376 gram; bismuth present, 0.2694 gram. As Neumann remarks (*Elektrolyse*, p. 181), the possible current strength is exceedingly low, hence a long time is required for the precipitation of the mercury.

However, Chapin in this laboratory used a rotating dish anode performing 250 revolutions per minute and reduced the time factor to twenty-five minutes. The condi-

tions observed by him were: Total volume of electrolyte 75 c.c., to which were added 10° of nitric acid of 1.4 sp. gravity. The temperature of the electrolyte was 50° and the pressure employed equaled 1.3 volts (J. Am. Ch. S., 32, 1476).

6. From Cadmium:—

(a) *In acid solution.* The nitric acid and sulphuric acid solutions lend themselves quite well to this separation. The proper conditions for the obtainment of satisfactory results are given in the section on mercury from aluminium, paragraphs *a* and *b* (p. 215).

(b) *In alkaline cyanide solution.* The solution contained 0.1182 gram of mercury and 0.2206 gram of cadmium. Two and one-half grams of pure potassium cyanide were added, and the liquid was then diluted with water to 125 c.c., heated to 65°, and acted upon with a current of $N.D._{100} = 0.018$ ampere and 1.7 volts. The precipitation was complete in 7 hours at the ordinary temperature (J. Am. Ch. S., 17, 612; also 21, 919).

7. **From Calcium.** See the separation of mercury from barium (p. 215).

8. **From Chromium.** The methods recommended for the separation of mercury from aluminium, p. 215, will answer for this particular purpose.

9. From Cobalt:—

(a) *In acid solutions.* See p. 215, under mercury from aluminium.

(b) *In alkaline cyanide solution.* The solution contained 0.1216 gram of mercury and 0.1000 gram of cobalt. The liquid was diluted to 100 c.c.; 2 grams of potassium cyanide were added to it and the liquid, then heated to 65°, was electrolyzed with $N.D._{100} = 0.025-0.03$ ampere

and 2.06–2.7 volts for 5 hours. The mercury found equaled 0.1213 gram and 0.1217 gram. Too much potassium cyanide exercises a retarding influence on the precipitation of the mercury (J. Am. Ch. S., 21, 918; Am. Ch. Jr., 12, 104).

10. From Copper:—

(a) *In nitric acid solution.* Freudenberg (Z. f. ph. Ch., 12, 111), with attention to voltage alone, separates these metals as follows: To their solution (the nitrates) add several cubic centimeters of nitric acid (sp. gr. 1.2) and 2 to 4 grams of ammonium nitrate, after which electrolyze with a current having a pressure of 1.3 volts. Mercury present, 0.2380 gram; copper present, 0.1356 gram; mercury found, 0.2377 gram; copper found, 0.1358 gram. The separation was made during the night.

(b) *In alkaline cyanide solution.* It was in a solution of the double cyanides of these metals that they were first separated successfully in the electrolytic way (Am. Ch. Jr., 11, 264). At the time it was thought that the separation could not be regarded as yielding trustworthy results when the copper exceeded 20 per cent., but about two years subsequently it was shown (Jr. An. Ch., 5, 489) that by careful adjustment of the current strength the quantity of copper could not only equal, but exceed, that of the mercury almost indefinitely (Spare and Smith, J. Am. Ch. S., 23, 579). The time, however, was still an important factor, and it was not reduced by Freudenberg, who electrolyzed the double cyanides with a pressure of 2.5 volts, in the presence of 2 to 4 grams of potassium cyanide (Z. f. ph. Ch., 12, 113). The reduction of this factor was made in 1894 (J. Am. Ch. S., 16, 42) by gently warming the electrolyte. It then became possible to fully precipitate

the mercury in three and one-half hours. Since then the separation has been repeatedly made both with mercury and copper (J. Am. Ch. S., 21, 917), and with mercury, copper, cadmium, zinc, and nickel simultaneously present. The following conditions will prove satisfactory for this separation: Mercury present, 0.1216 gram; copper present, equal amount; total dilution, 125 c.c.; potassium cyanide, 2-3 grams; temperature, 65°; time, 2½-3 hours. Mercury found, 0.1215 gram (Revay, Z. f. Elektrochem., 4, 313).

11. From Gold. This separation has not been made. See Z. f. ph. Ch., 12, 113.

12. From Iron:—

(a) *In nitric acid solution.* Use the conditions indicated under *a*, mercury from aluminium (p. 215).

(b) *In sulphuric acid solution.* See *b* under mercury from aluminium.

(c) *In alkaline cyanide solution.* Dissolve ferrous ammonium sulphate in water; conduct sulphur dioxide through it to reduce any ferric salt which may be present, nearly neutralize the excess of acid with sodium carbonate, mix with the solution of the silver salt, and add from 2.5 to 4 grams of potassium cyanide for 0.2-0.4 gram of the combined metals; then electrolyze with $N.D._{100} = 0.02-0.05$ ampere and 2.5 volts, with a temperature of 70°. The total dilution should equal 125 c.c. Time, 3-4 hours (J. Am. Ch. S., 21, 920).

13. From Lead. To the solution containing the two metals add from 25 to 30 c.c. of nitric acid (sp. gr. 1.3), dilute to 175 c.c. with water, and electrolyze with a current of $N.D._{100} = 0.13$ to 0.18 ampere and 2 volts, at 30° for 4 hours. It will, of course, be understood that the lead is deposited as dioxide upon the anode while the mercury is simul-

taneously precipitated on the cathode. Use a dish as anode (Smith and Moyer, Jr. An. Ch., 7, 252; Z. f. anorg. Ch., 4, 267; Heidenreich, Ber., 29, 1585; Z. f. Elektrochem., 3, 151).

14. **From Magnesium.** See the separation of mercury from barium, etc., p. 217.

15. **From Manganese:—**

(a) *In nitric acid solution.* See the conditions under which manganese is precipitated as dioxide (p. 138). The mercury separates at the cathode.

(b) *In sulphuric acid solution.* The conditions which should be observed in depositing manganese from a solution containing free sulphuric acid will answer in this particular separation (p. 138). The larger dish must, of course, be made the anode. The quantities of the two metals must not be too large.

16. **From Molybdenum.** The separation is readily effected in an alkaline cyanide solution, using the conditions prescribed under *b* in the separation of mercury from arsenic (p. 217).

17. **From Nickel:—**

(a) *In nitric acid solution.* Follow the conditions given under *a* in the separation of mercury from aluminium, p. 215, or those mentioned in J. Am. Ch. S., 32, 1472.

(b) *In sulphuric acid solution.* Reproduce the conditions of *b* in the separation of mercury from aluminium, p. 216.

(c) *In alkaline cyanide solution.* An example will illustrate: Mercury present, 0.1216 gram; nickel present, 0.1500 gram; potassium cyanide, 2–2.5 grams; total dilution, 125 c.c.; N.D.₁₀₀=0.04 ampere; volts=1.7–2.2; temperature, 65°; time, 4 hours. The mercury found equaled 0.1213 gram (J. Am. Ch. S., 21, 918; Am. Ch. Jr., 12, 104).

- 18. From Osmium.** Follow the directions for the separation of mercury from arsenic in an alkaline cyanide solution, p. 217. In this separation the quantity of alkaline cyanide should not exceed 1.5 grams for 0.2 gram of metal (Am. Ch. Jr., 12, 428; 13, 417; Jr. An. Ch., 6, 87).
- 19. From Palladium.** Let the conditions be the same as those given for the separation of mercury from platinum (see below) (Am. Ch. Jr., 12, 428).
- 20. From Platinum.** Example: Mercury present, 0.1373 gram; platinum present, 0.1000 gram; total dilution, 125 c.c.; potassium cyanide, 3 grams; $N.D._{100} = 0.04-0.05$ ampere; $V = 2.1$; temperature, $65^{\circ}-75^{\circ}$; time, 4 hours. The mercury found equaled 0.1372 gram (Am. Ch. Jr., 13, 417; J. Am. Ch. S., 21, 920).
- 21. From Potassium.** See mercury from barium, etc., p. 217.
- 22. From Selenium.** To the solution of the two metals, each about one quarter of a gram in amount, add one gram of potassium cyanide, dilute to 150 c.c. with water, heat to 60° C., and electrolyze with $N.D._{100} = 0.03$ ampere and a pressure of 3 volts. The precipitation of the mercury will be complete in five hours.
- In a nitric acid electrolyte the separation is conducted with ease by observing the conditions followed in the separation of silver from selenium, p. 245.
- 23. From Silver.** These metals cannot be separated electrolytically either in an acid or alkaline cyanide solution. Classen precipitates them together, and after ascertaining their combined weight expels the mercury by ignition and weighs the residual silver.
- 24. From Sodium.** See barium, p. 217.
- 25. From Strontium.** See mercury from calcium, etc., p. 217.

26. From Tellurium. In a cyanide solution the separation cannot be made. Most favorable results were obtained in a nitric acid electrolyte. An example will illustrate. To a solution containing 0.1272 gram of mercury and 0.2500 gram of sodium tellurate, three cubic centimeters of nitric acid (sp. gr. 1.43) were added. After dilution to 150 c.c. with water it was heated to 60° C., and electrolyzed with a current of $N.D._{100} = 0.04$ to 0.05 ampere and a pressure of 2 to 2.5 volts. In five hours the precipitation was finished (J. Am. Ch. S., 25, 895).

27. From Tin:—

(a) *In alkaline sulphide solution.* The conditions mentioned under mercury (p. 98) will answer perfectly for this separation (Jr. Fr. Ins., 1891). To change the sodium sulpho-salt in the filtrate into ammonium sulphostannate consult p. 169.

(b) *In ammoniacal tartrate solution.* A solution of the two metals was made by adding mercuric chloride to tartaric acid, followed by ammonia water and then diluting with water. This solution was then mixed with the tin salt solution and the combined liquids electrolyzed with a current showing a pressure of from 1.6–1.7 volts. (See the separation of mercury from antimony in tartrate solution, p. 216; also J. Am. Ch. S., 15, p. 204.)

It may be of interest to state that the conditions given for the separation of mercury from antimony (p. 216), and those just employed above for the separation of mercury from tin have been successfully applied by Schmucker (J. Am. Ch. S., 15, 204) for the electrolytic separation of mercury from a solution containing arsenic, antimony, and tin, the only change being in the addition of an increased amount of tartaric acid

- and ammonium hydroxide. Example: Mercury, 0.0933 gram; arsenic, 0.1009 gram; antimony, 0.1031 gram; tin, 0.1000 gram; tartaric acid, 8 grams; ammonium hydroxide, 30 c.c.; dilution, 175 c.c.; $N.D._{100} = 0.05$ ampere; volts = 1.7. The precipitation made at 60° was complete in 6 hours.
28. **From Tungsten.** Use conditions corresponding to those employed in the separation of mercury from arsenic in an alkaline cyanide solution (p. 217).
29. **From Uranium.** There is no recorded electrolytic separation of these metals, but it is quite probable that methods *a* and *b*, under mercury from aluminium (p. 215), would be applicable in this case.
30. **From Vanadium.** They have not been separated by the current.
31. **From Zinc:—**
- (a) *In acid solutions* (nitric or sulphuric) the conditions mentioned under *a* and *b*, in the separation of mercury from aluminium, will prove perfectly satisfactory (p. 215).
- (b) *In alkaline cyanide solution.* This separation has been made repeatedly with excellent success, so that perhaps an actual example will give all the data necessary to guide others in making the separation: Mercury present, 0.1158 gram; zinc present, 0.1000 gram; potassium cyanide, 1.5 to 2 grams; dilution, 125 c.c.; $N.D._{100} = 0.025 - 0.05$ ampere; $V = 2.5$ to 3; time, 4 hours; temperature, 60°. Mercury found, 0.1155 gram (J. Am. Ch. S., 21, 919; Jr. Fr. Ins., 1889).
- (c) *In phosphoric acid solution.* An example from many results will show the conditions which should be pursued in conducting the separation in a solution such as just indicated: 25 c.c. of mercuric chloride = 0.1159 gram of

metal; 25 c.c. of zinc sulphate=0.1010 gram of metal; 60 c.c. of disodium hydrogen phosphate (1.038 sp. gr.); 10 c.c. of phosphoric acid (1.347 sp. gr.); total dilution, 175 c.c.; temperature, 60°; N.D.₁₀₀=0.01 ampere; V=1.5; time, 4-5 hours. Mercury found, 0.1163 gram (J. Am. Ch. S., 21, 1006).

BISMUTH.

The separations of this metal from other metals in the electrolytic way are not numerous, but they are, notwithstanding, of decided help to the analyst, and therefore will be here presented in such detail as is known.

1. **From Aluminium.** The conditions given under bismuth for its determination in a nitric (p. 100) or sulphuric acid solution (p. 101) can be here used for its separation from aluminium. Its precipitation as an amalgam (p. 103) is well adapted for this purpose.
2. **From Antimony.** To the solution containing the two metals add 5 grams of tartaric acid, 15 c.c. of ammonium hydroxide, dilute to 175 c.c. with water, and electrolyze with a current of N.D.₁₀₀=0.022 ampere and 1.8 volts at 50° for 6 hours (J. Am. Ch. S., 15, 203).
3. **From Arsenic.** The course just outlined for the separation of bismuth from antimony will answer in this case (J. Am. Ch. S., 15, 202). Neumann (*Elektrolyse*, p. 185) states that the two metals, if in sulphate solution, can be separated with a current having an *E. M. F.* of 1.9 volts.
4. **From Barium.** The conditions for the precipitation of bismuth from nitric acid solution (p. 100) will answer for this separation.
5. **From Cadmium.** This separation may be conducted in the presence of free nitric acid (p. 100), by the amalgam method (p. 103), or in a sulphuric acid solution. If

using the last electrolyte, proceed as follows: Dissolve 0.1500 gram of cadmium metal in 2 c.c. of concentrated sulphuric acid (sp. gr. 1.84) and to this solution add another of 0.15 gram of bismuth and 1 c.c. of concentrated nitric acid, 1 gram of potassium sulphate, and dilute with water to 150 c.c., heat to 50°, and electrolyze with a current of $N.D._{100}=0.025$ ampere and 2 volts. Time, 8 hours. The bismuth will be deposited in a bright, metallic form (Kammerer).

6. From Calcium. The conditions given on pp. 100-104 for the determination of bismuth may be relied upon in making this separation.

7. From Chromium. Use a nitric acid solution (p. 100), or adopt the method given in the following paragraph:—

To a solution of bismuth containing 0.1500 gram of metal and 1 c.c. of nitric acid (sp. gr. 1.42), add 0.5 gram of potassium sulphate, 2 c.c. of sulphuric acid (sp. gr. 1.84), and a quantity of chrome alum equivalent to 0.1500 gram of chromium. Dilute to 150 c.c. with water and electrolyze with a current strength of $N.D._{100}=0.025$ ampere and 2 volts, the temperature being maintained at 50° C. After 8 hours the deposition will be complete and the bismuth will be free from chromium.

RESULTS.

BISMUTH TAKEN.	BISMUTH FOUND.	CHROMIUM.	POTASSIUM SULPHATE.	SULPHURIC ACID.	DILUTION.	TIME.	TEMPERATURE.	N.D. ₁₀₀ .	VOLTS.	STYLE OF ANODE.
Grm.	Grm.	Grm.	Grm.	C.c.	C.c.	Hours.	°C.	Amp.		
0.1434	0.1430	0.1500	0.5	2	200	9	50	0.03	2	Gauze.
0.1434	0.1428	0.1500	0.5	2	150	9	50	0.025	2	Basket.
0.1434	0.1434	0.1500	0.5	2	200	8½	50	0.025	2	Gauze.
0.1434	0.1428	0.1500	0.5	2	150	8½	50	0.02	2	Basket.
0.1434	0.1430	0.1500	0.5	2	150	8½	50	0.02	2	Spiral.
0.1434	0.1429	0.1500	0.5	2	150	9	50	0.025	2	"

The chromium salt seems to exert a beneficial influence on the character of the deposit. Much of the chromium, during the electrolysis, is oxidized to chromic acid. Especially is this true when gauze electrodes are used (Kammerer).

8. From Cobalt. Proceed as in the separation from aluminium (p. 225), or from chromium (above).

9. From Copper. In a nitric acid solution copper and bismuth cannot be separated electrolytically. This statement has been the subject of considerable controversy in past years (*Z. f. anorg. Ch.*, **3**, 415; **4**, 234; **5**, 197; **6**, 43; *Z. f. ph. Ch.*, **12**, 117), so that all that remains to chemists is the suggestion made in the *Am. Ch. Jr.*, **12**, 428—viz., add from 3 to 4 grains of citric acid to the bismuth solution, supersaturate the latter with sodium hydroxide, and into this mixture pour the copper salt solution, containing a slight excess of potassium cyanide, and electrolyze at the ordinary temperature with a current of $N.D._{100} = 0.05$ ampere and 2.7 volts. In 9 hours the bismuth will be fully precipitated and will not contain any copper.

Hollard and Bertiaux, *Ch. Z.*, **28**, 782, describe a separation of bismuth from copper, which is essentially an ordinary gravimetric precipitation, for they add an excess of phosphoric acid to a boiling solution of the two sulphates. The solution is allowed to stand over night. The bismuth phosphate is filtered off and washed with dilute phosphoric acid (1 volume of acid of sp. gr. 1.711 diluted to 20 volumes). The final washing is performed with ammonium sulphhydrate and potassium cyanide. The bismuth phosphate is dissolved in nitric acid and the solution then evaporated in the presence of 12 c.c. of sulphuric acid until fumes escape. Now dilute to 300 c.c. and electrolyze with a current of $N.D._{100} = 0.1$ ampere. Twenty-four hours will be necessary for the precipitation.

10. From Gold. There is no recorded electrolytic separation of these metals.

11. From Iron. The acid solutions and conditions, given on pp. 100, 101, will answer in this case. It may be remarked here that the deposition of bismuth from sulphuric acid solutions containing iron is attended with considerable difficulty. The iron present seems to exert an influence on the bismuth, tending to hold it in solution and prevent its deposition by the current. Especially is this true when the salt used is a ferric salt. This tendency of bismuth to be held in solution is shown even in a more marked degree when the liquid contains, besides ferric alum, an equal quantity of chrome alum. A current of 0.1 ampere will often not cause the slightest precipitation of bismuth. It was thought that this behavior of bismuth could be used to separate other metals from it. It was hoped that the bismuth would be held back by the iron and chrome alums and such metals as mercury, copper, and silver be deposited from the solution. These hopes were not realized. As soon as another metal is introduced the condition of affairs is changed, and both the metal and the bismuth are precipitated. Deposits of silver, however, were obtained containing but very little co-precipitated bismuth. Further investigation in this direction might lead to some very interesting and valuable results.

The best conditions for the separation of bismuth from iron were found to be as follows: To the bismuth solution containing 0.15 gram of bismuth and 1 c.c. of concentrated nitric acid, add 2 c.c. of sulphuric acid (sp. gr. 1.84), 0.5 gram of potassium sulphate, and a quantity of ferrous sulphate or ammonium ferric alum equivalent to 0.15 gram of iron. This solution should be diluted to 150 c.c.

and electrolyzed at a temperature of 45° C. If a ferrous salt is used, the current strength should be 0.03 ampere, but if a ferric salt is in solution, a higher current strength should be employed,—0.05 ampere,—the voltage in both cases being 2.0. In eight hours the deposition will be complete. The precipitated bismuth is free from iron, (Kammerer).

In several cases the separation was made in the presence of urea nitrate, but its addition was no advantage.

RESULTS.

BISMUTH TAKEN.	BISMUTH FOUND.	IRON TAKEN.	UREA NITRATE.	POTASSIUM SULPHATE.	DILUTION.	SULPHURIC ACID.	TIME.	TEMPERATURE.	N.D. ¹⁰⁰ .	VOLTS.	STYLE OF ANODE.
Grm.	Grm.	Grm.	Grm.	Grm.	C.c.	C.c.	Hours.	°C.	Amp.		
0.1434	0.1429	0.1500 ¹	—	0.5	150	2	8½	50	0.025	1.5	Spiral.
	0.1431	0.1500 ¹	—	0.6	150	2	7½	45	0.03	2	“
	0.1435	0.1500 ¹	—	0.5	150	2	24	45	0.03	2	“
	0.1430	0.1500 ¹	—	0.5	150	2	24	45	0.03	1.7	Basket.
0.1395	0.1394	0.1500 ¹	0.5	0.2	150	2	8	45	0.035	2	“
	0.1400	0.1500 ¹	0.5	0.2	150	2	8	50	0.035	2	Spiral.
	0.1393	0.1500 ¹	0.5	0.2	200	2	8	45	0.05	2	Gauze.
	0.1397	0.1500 ²	—	0.5	150	2	9	45	0.07	2	Spiral.
	0.1395	0.1500 ²	—	1	150	2	9	45	0.06	2	“
	0.1394	0.1500 ²	—	1	200	2	8	45	0.06	2	Gauze.
	0.1395	0.1500 ²	3.0	0.5	150	2	9	45	0.035	2	Spiral.

¹ Ferrous sulphate.

² Ferric ammonium sulphate.

12. From Lead. Experiments made in this laboratory (Jr. An. Ch., 7, 252) have demonstrated that the generally accepted statement that the metals could be separated in the presence of free nitric acid is not correct. The lead dioxide invariably contained bismuth. We are, therefore, for the present at least, without an electrolytic method for their separation.

Holland and Bertiaux—B. Soc. Ch., 31, 1133 (1904)—recommend adding to the two nitrates 12 c.c. of sul-

phuric acid plus the requisite amount of this acid to combine with the two metals, viz., for lead 0.3 c.c. and for bismuth 0.5 c.c., then evaporate until white fumes arise. Cool. Add water to 300 c.c. and 35 c.c. of absolute alcohol. Electrolyze with a current of 0.1 ampere for a period of 48 hours.

13. From Magnesium. The acid solutions and conditions given for the separation of bismuth from aluminium (p. 225) will serve to effect this particular separation.

14. From Manganese. To the bismuth solution containing 0.1500 gram of metal and 1 c.c. of nitric acid (sp. gr. 1.42) add 3 c.c. of sulphuric acid (sp. gr. 1.84), 0.5 gram of potassium sulphate, and a quantity of manganous sulphate equivalent to 0.1500 gram of manganese. Dilute this solution to 150 c.c. with water and electrolyze with a current of N.D.₁₀₀ = 0.025 ampere and 2 volts, keeping the temperature at 45° C. The bismuth will be deposited in 9 hours in a beautiful form, free from manganese.

At first the solution assumes a dark red color due to the oxidation of some of the manganese into permanganic acid. After an hour or two the color begins gradually to fade away and the solution again becomes colorless. A considerable quantity of hydrated oxide of manganese deposits on the anode during the electrolysis. This deposit was always examined for bismuth, but in no case was it found to contain any of this metal (Kammerer and Am. Ch. Jr., 8, 206).

15. From Mercury. See the separation of mercury from bismuth, p. 217.

16. From Molybdenum. Observe the conditions mentioned under the separation of bismuth from tungsten.

17. From Nickel. The directions recorded on pp. 100-103 for the determination of bismuth in acid solutions may be

followed with confidence in making this separation (Am. Ch. Jr., 8, 206; Jr. An. Ch., 7, 252; Z. f. anorg. Ch., 4, 270; J. Am. Ch. S., 32, 1471).

18. From Palladium and Platinum. Separations are not known.

19. From Potassium. Follow the methods given for the determination of bismuth itself, pp. 100-103.

20. From Selenium. There is no existing electrolytic method.

21. From Silver. Freudenberg (Z. f. ph. Ch., 12, 108) uses the nitrates of the two metals, adds to their solution several cubic centimeters of nitric acid of sp. gr. 1.2 and from 2 to 4 grams of ammonium nitrate, then electrolyzes with a current having a potential of 1.3 volts. The silver is precipitated through the night. The liquid containing the residual bismuth may be worked for the determination of the bismuth by the amalgam method, p. 103, although it would appear that Freudenberg always determined it by evaporation of the nitric acid solution and ignition of the residue, finally weighing bismuth oxide. The results obtained by him are:—

Silver used, 0.3790 gram; Bi = 0.3080 gram

Silver found, 0.3793 gram; Bi = 0.3073 gram

Silver used, 0.2916 gram; Bi = 0.3085 gram

Silver found, 0.2914 gram; Bi = 0.3072 gram

See p. 238, and also J. Am. Ch. S., 32, 1476.

22. From Sodium. Any one of the methods pursued in the determination of bismuth when alone will do for this purpose (pp. 100-103).

23. From Strontium. See the separation of barium from bismuth, p. 225.

24. From Tellurium. There is no recorded electrolytic separation.

25. From Tin. The solution contained 0.0518 gram of bismuth and 0.1031 gram of tin. To it were added 5 grams of tartaric acid and 15 c.c. of ammonium hydroxide, and the liquid then diluted to 175 c.c. with water and electrolyzed at the ordinary temperature with $N.D._{100} = 0.02$ ampere and 1.8 volts, during the night (*J. Am. Ch. S.*, **15**, 204).

The chemist who proposed the preceding method also separated bismuth from a mixture of arsenic, antimony, and tin. The solution with which he operated contained 0.0518 gram of bismuth, 0.1009 of arsenic, 0.1024 gram of antimony, and 0.1031 gram of tin. To it were added 8 grams of tartaric acid and 3 c.c. of ammonium hydroxide, then diluted to 175 c.c. with water and electrolyzed with a current of $N.D._{100} = 0.02$ ampere and 1.9 volts, at the ordinary temperature. The precipitation was made during the night. The time factor can probably be reduced by the application of a gentle heat. The bismuth precipitates rapidly and in an adherent form.

26. From Tungsten. This separation may be made without trouble. One example will suffice to show the proper conditions: To a solution containing 0.1926 gram of bismuth as metal and 0.1862 gram of tungsten as sodium tungstate add 3 grams of tartaric acid and 0.5 gram of sodium hydroxide, then electrolyze with a current of $N.D._{100} = 0.2$ ampere and a pressure of 3 volts. Rotate the anode. Time, 30 minutes.

27. From Uranium. The conditions presented on p. 101 for the determination of bismuth in sulphuric acid solution will serve excellently in making this separation (*Am. Ch. Jr.*, **8**, 206). See also bismuth from chromium.

28. From Vanadium. There is no recorded separation.

29. From Zinc. The conditions given in the determination of bismuth in nitric acid (p. 100), sulphuric acid (p. 101), and as amalgam (p. 103) will be found satisfactory in this separa-

tion (Am. Ch. Jr., 8, 206; Jr. An. Ch., 7, 255). See also bismuth from cobalt.

LEAD.

The importance of lead industrially makes not only its accurate determination of interest and value, but its separation from the metals frequently associated with it becomes a matter of deep concern. It will be generally conceded that lead is a metal that is best determined by the electrolytic procedure; this is vastly better than the ordinary gravimetric processes, and this, too, increases the value of its separations.

- 1. From Aluminium.** As aluminium is not precipitated electrolytically from a nitric acid solution and the latter is especially well adapted for the deposition of lead in the form of its dioxide upon the anode, the conditions laid down upon p. 107 will be found to answer admirably in effecting the present separation.
- 2. From Antimony.** A purely electrolytic procedure is at the present not known for the separation of these metals. In the Ch. Z., 19, 1142 (1895), Nissenson and Neumann described a method for the analysis of an alloy of antimony and lead, which deserves attention here. It is not an electrolytic separation in any sense of that term, but a helpful suggestion.

The finely divided alloy is brought into solution with 4 c.c. of nitric acid (sp. gr. 1.4), 15 c.c. of water, and 10 grams of tartaric acid. Four cubic centimeters of concentrated sulphuric acid are added to the clear solution, which is then diluted with water, allowed to cool, and filled up to the mark of the $\frac{1}{4}$ -liter flask. On filtering from the lead sulphate, which has separated, the filtrate will contain all of the antimony. None will remain in the lead sulphate. Remove 50 c.c. of the filtrate with a pipette,

render it strongly alkaline with caustic soda, add 50 c.c. of a cold saturated sodium sulphide solution, boil, filter at once, wash and electrolyze the hot solution with a current of $N.D._{100} = 1.5-2.0$ amperes. An hour at the most will be required for the deposition of the antimony.

The lead sulphate should be digested for a few minutes with ammonia water. This changes it to hydroxide, which can be gradually introduced into a platinum dish containing 20 c.c. of nitric acid, in which it slowly dissolves. The liquid is then electrolyzed with the conditions indicated on p. 107.

3. **From Arsenic.** Neumann (Ch. Z., 20, 382) records his experience in attempting to separate these metals electrolytically, from which the conclusion may be deduced that in the presence of arsenic the lead determinations are not reliable. They are too low. When there is only a fraction of a per cent. of arsenic present, the results can be used, although the time then necessary for the complete precipitation of the lead as dioxide is prolonged to an unwarrantable degree. The experiments of Neumann were all conducted in nitric acid solution.
4. **From Barium, Strontium, Calcium, Magnesium, the Alkali Metals, Beryllium, Cadmium, Chromium, Iron, Uranium, Zirconium, Zinc, Nickel, and Cobalt** the separation of lead is easily made by observing the conditions given (p. 107) for its determination. There should be from 15 to 20 per cent. of concentrated nitric acid present. The liquid poured off from the deposit of lead peroxide is changed into the most favorable salt for the precipitation of the particular metal and the electrolysis proceeded with in the usual way.
5. **From Bismuth.** See p. 229.
6. **From Copper.** This separation has always been made in the presence of free nitric acid. The details of procedure are described under copper from lead, p. 194.

7. **From Gold.** This combination of metals has, apparently, not received any attention in the electrolytic way, as the separation can be made more satisfactorily in other ways.

8. **From Manganese :—**

(a) *In nitric acid solution.* It is well known that manganese can be precipitated from solutions in which the quantity of free nitric acid does not exceed from 3 to 5 per cent. Greater quantities of the acid prevent its appearance, its presence being made evident by the pink tinge of permanganic acid about the anode. As lead is completely deposited even in the presence of from 15 to 20 per cent. of acid, it would seem as if the separation could be made under the latter conditions. Neumann recommends heating the solution containing the two metals and 20 per cent. of concentrated nitric acid to 70° , then electrolyzing with a current of from 1.5 to 2 amperes and 2.5 to 2.7 volts. It is absolutely essential to use hot solutions, strong currents, and not too large quantities of manganese (0.03 gram of manganese at the most in 150 c.c. of liquid). When large amounts are employed and the electrolysis is prolonged, the liquid will very probably become turbid, owing to the separation of dioxide of manganese (Ch. Z., 20, 383).

(b) *In phosphoric acid solution.* Linn adds to the solution of the two nitrates a little more disodium hydrogen phosphate than necessary for complete precipitation. The phosphates are then dissolved in an excess of pure phosphoric acid (sp. gr. 1.7) and the solution electrolyzed with $N.D._{100} = 0.003$ to 0.006 ampere and a pressure of from 2 to 3 volts. Wash the deposit of lead with water, alcohol and ether, then dry at 100° – 110° C. (J. Am. Ch. S., 29, 82).

9. **From Mercury.** The details of this separation are given under mercury from lead, p. 220.

10. From Nickel. This separation may be easily made by observing the conditions which are followed in the ordinary precipitation of lead as dioxide from a nitric acid solution (J. Am. Ch. S., 32, 1472).

11. From Selenium. As selenium materially affects the deposition of lead as dioxide from a nitric acid solution, it may be of interest to present some results from Neumann's experiments (Ch. Z., 20, 383). They are instructive and suggestive. He used solutions of lead nitrate containing sodium selenite. The first experiment was with lead alone, the others contain the two metals:—

LEAD PRESENT.	SELENIUM PRESENT.	NITRIC ACID.	LIQUID.	TIME.	AMPERES.	VOLTS.	LEAD.
0.2238	0.0000	30 c.c.	150 c.c.	1 hr.	0.8	3	0.2238
0.2238	0.0050	30	150	1	0.8	3	0.2208
0.2238	0.0100	30	150	1	0.8	3	0.2156
0.2238	0.0200	30	150	1	0.8	3	0.1886
0.2238	0.0500	30	150	1	0.8	3	0.0327

As the quantity of selenium was increased, the amount of lead dioxide deposited grew less. This was the case with lead and arsenic. The cathode also carried a deposit consisting of metallic lead and selenium.

12. From Silver:—

In nitric acid solution. An example, taken from a number made in this laboratory, will give the best conditions for carrying out this separation: To a solution containing 0.1028 gram of silver and lead equal to 0.0144 gram of dioxide, were added 15 c.c. of nitric acid of 1.3 specific gravity. After dilution to 200 c.c. it was electrolyzed with a current of $N.D._{100} = 0.18$ ampere and 2.25 volts. The deposit of silver weighed 0.1023 gram and that of the dioxide 0.0144 gram. It is probably not necessary to say

that the depositions were simultaneous and that the precautions described under the individual metals were carefully observed. It must be borne in mind that silver quite often separates in the presence of nitric acid both as peroxide at the anode and as metal at the cathode, so that Luckow recommends the presence of at least 18 per cent. of nitric acid and also introduces several drops of oxalic acid, thus hindering the precipitation of silver dioxide (Jr. An. Ch., 7, 252; Z. f. anorg. Ch., 1890, 345). See also Arth and Nicholas, B. S. Ch. de Paris [3], Tome 29-30, p. 633.

13. **From Tellurium.** This separation has not received any attention.
14. **From Tin.** In this instance the usual gravimetric procedure is the preferable course to adopt in making the separation.

SILVER.

The current has proved a most valuable reagent in the separation of this metal from many others which occur associated with it. The ease and accuracy of these various separations recommend them.

1. **From Aluminium.** The conditions given on p. 109 for the precipitation of silver from a nitric acid solution will answer for this separation.

In using the *rotating anode* dilute the solution to 125 c.c., add 1 c.c. of nitric acid of sp. gravity 1.43 and 1 gram of ammonium nitrate, then electrolyze with $N.D._{100}=3$ amperes and 3.5 volts. The time will be fifteen minutes for a quarter of a gram of metal or more. This same procedure will serve in the rapid separation of silver from cadmium, chromium, cobalt, iron, lead, magnesium, manganese, nickel and zinc (J. Am. Ch. S., 26, 1290).

2. From Antimony :—

- (a) *In ammoniacal solution.* In accordance with the suggestion of Freudenberg (*Z. f. ph. Ch.*, **12**, 109), if the antimony be raised to its highest state of oxidation it will only be necessary to add ammonium sulphate and ammonia water to the solution of the combined metals and electrolyze with a current having a pressure varying from 1.2 to 1.3 volts. The precipitated metal will not adhere well to the dish, so that the method will be used only when special reasons demand it.
- (b) *In acid solution.* To the nitric acid solution add tartaric acid, after having converted all the antimony into pentoxide, and electrolyze with a pressure not exceeding 1.4 to 1.5 volts. Freudenberg remarks that the deposit of silver is not well suited for weighing.
- (c) *In potassium cyanide solution.* The antimony should exist as pentoxide. After adding tartaric acid to the cyanide solution (1 gram of pure potassium cyanide for every 0.1 gram of metal), electrolyze with a pressure of from 2.3 to 2.4 volts.

Fischer found procedures (b) and (c) very satisfactory, *Ber.*, **36**, 3297, and *Z. f. Elektrochem.*, **9**, 993.

- 3. From Arsenic.** The methods just described for the separation of silver from antimony will be found applicable in this case (*Am. Ch. Jr.*, **12**, 428).
- 4. From Barium.** Follow the instructions given on p. 109 for the determination of silver.
- 5. From Bismuth.** See p. 231, bismuth from silver. And to the solution containing from 0.1 to 0.2 gram of each metal add 3 c.c. of nitric acid of 1.4 sp. gravity, dilute to 75 c.c. with water, heat to 60° and electrolyze with a pressure of 3 volts and a current of $N.D._{100} = 0.15$ to 0.20 ampere. Use a dish anode and let it perform 250 revolutions per minute.

It should be so adjusted as to be about 3 mm. from the dish cathode. Keep the voltage constant and continue the electrolysis until the amperage falls to 0.002. Twenty-five minutes will suffice to effect the separation (J. Am. Ch. S., 32, 1476).

6. From Cadmium:—

(a) *In nitric acid solution.* To the solution of the salts of the two metals add 15 to 20 c.c. of nitric acid of specific gravity 1.3, heat to 60°, and electrolyze with a current having a pressure of from 2 to 2.2 volts. The silver will be precipitated and should be treated as directed on p. 111. The acid filtrate can, by the addition of an excess of sodium acetate, be changed to a suitable form for the deposition of the cadmium. See p. 91.

(b) *In potassium cyanide solution.* Add 2 grams of pure potassium cyanide to the solution, containing 0.1–0.2 gram of each metal, dilute to 125 c.c., heat to 65°–75°, then conduct a current of $N.D._{100} = 0.02-0.025$ ampere and 2.1 volts through the liquid. The silver will be completely precipitated at the expiration of from 4 to 5 hours. After removing the liquid from the precipitating dish it should be reduced in volume, introduced into a second weighed platinum dish, and electrolyzed as directed on p. 89 for the deposition of the cadmium.

7. **From Calcium and Chromium.** See p. 237.

8. **From Cobalt.** An example will show the conditions which have been found very satisfactory in this particular separation: To the solution of the silver salt (0.1024 gram of silver) were added 0.1 gram of cobalt as nitrate and 2.75 grams of pure potassium cyanide. The liquid was diluted to 125 c.c. with water, heated to 65° C., and electrolyzed with $N.D._{100} = 0.038$ ampere and 2 volts. At the expiration of 5 hours the silver was completely deposited. It weighed

0.1027 gram. It contained no cobalt (J. Am. Ch. S., 21, 915). This procedure is preferable to the deposition of silver from a nitric acid solution.

9. From Copper:—

(a) *In nitric acid solution.* Freudenberg added 2 to 3 c.c. of nitric acid of 1.2 specific gravity to the solution of salts of the two metals, then electrolyzed with a pressure of 1.3–1.4 volts, and a current of 0.1 ampere. The silver was deposited free from copper (Z. f. ph. Ch., 12, 107; Berg-Hütt. Z. (1883), 375).

At the ordinary temperature this separation will require 7 hours, while at 60° the precipitation of the silver will be finished in 4 hours. The liquid siphoned off from the silver, after the addition of nitric acid, can be electrolyzed in a beaker in which a platinum cone is suspended. The copper is precipitated on the cone. A current ranging from 0.5 to 1.0 ampere will be required for this. The solution should be heated to 60°–65°.

The plan is ideal, but those who have attempted to repeat Freudenberg's work have encountered difficulties, and naturally modifications of the procedure have been proposed. Küster and v. Steinwehr (Z. f. Elektrochem., 4, 451), in particular, have made an exhaustive investigation of the precipitation of silver from nitric acid and its separation from copper in the presence of the latter acid. Their conclusion is briefly that the solution should contain from 1 to 2 c.c. of nitric acid (sp. gr. 1.4), and that to it should be added 5 c.c. of alcohol. Further, that the potential of the electrolyte should be kept constantly at 1.35–1.38 volts. An example will show how they operated: A weighed piece (0.3161 gram) of silver coin was dissolved in 2 c.c. of nitric acid (sp. gr. 1.4), the liquid was diluted to 150 c.c., 5 c.c. of alcohol were added, and the

solution then heated to 55° and electrolyzed with 1.36 ± 0.01 volt. They obtained 0.2839 gram of silver ≈ 89.83 per cent.

(b) *In potassium cyanide solution.* This separation was first made by Smith and Frankel (Am. Ch. Jr., 12, 104) and has been carried out over a hundred times in this laboratory by experienced persons and by those who lacked experience, but in all cases the results have been most satisfactory.

Add 2 grams of pure potassium cyanide to the solution of mixed salts, heat to 65° , and electrolyze the liquid (125 c.c.) with a current of $N.D._{100} = 0.03 - 0.058$ ampere and 1.1-1.6 volts. The silver will be precipitated in from 4 to 5 hours. It will, of course, be understood that if there be a great preponderance of copper over the silver the quantity of potassium cyanide will have to be increased. Example: A solution contained 0.1066 gram of silver and 0.5265 gram of copper. Four grams of pure potassium cyanide were added, the liquid was heated to 60° and electrolyzed for $3\frac{1}{2}$ hours with a current of $N.D._{100} = 0.02 - 0.03$ ampere and 1.2 volts. The silver deposit weighed 0.1066 gram. The total dilution was 125 c.c.

The presence of three or four metals besides the silver also requires the addition of more alkaline cyanide (J. Am. Ch. S., 23, 582, also Brunck, Ber., 34, 1604; Revay, Z. f. Elektrochem., 4, 313).

In the preceding electrolyte it is easy to separate silver from copper when using a *rotating anode*. To the solution of the metals add 2 grams of potassium cyanide, heat almost to boiling and electrolyze with $N.D._{100} = 0.4$ to 0.1 ampere and 2.5 volts. Fifteen minutes will suffice for the precipitation.

To show how this procedure may be applied in the

rapid analysis of a coin an example from the notebook of Miss Langness, working in this laboratory, may be introduced here.

A dime was cleaned and cut into four parts. One part was then weighed (0.7070 gram), dissolved in the least possible amount of nitric acid, the excess of acid evaporated, and the residue dissolved in water and diluted to 100 c.c. To 25 c.c. of this solution was added $\frac{1}{2}$ gram of potassium cyanide. The silver was first removed with a low current, and the decanted liquid after evaporation electrolyzed for the copper. The conditions used and results obtained are tabulated below.

No.	VOLTS.	AMPERES.	TIME. MIN.	WT. OF METAL.	PER CENT. OF METAL.
1	3-2.5	0.4-.06	35	0.1589 g. Ag.	89.90 per cent. silver.
	10	5	10	0.0177 g. Cu.	10.01 " " copper.
2	3-2.5	0.4-.06	45	0.1588 g. Ag.	89.84 " " silver.
	10	6	10	0.0180 g. Cu.	10.18 " " copper.

The complete analysis, including the weighing of the coin and the final weighing of the deposits, required about two and a half hours.

If two portions are taken, depositing the metals together in the one, and the silver alone in the other, the complete analysis can be made in an hour and a half, provided two dishes are available. One determination was made in that way. The coin weighing 0.5638 gram was dissolved in a small amount of nitric acid (less than 1 c.c.). Part of the excess of acid was evaporated and a few drops of ammonia added to neutralize the remaining excess. Two grams of potassium cyanide were then introduced and the solution diluted to 100 c.c. Twenty-five cubic centimeters of this solution diluted to about

125 c.c. were electrolyzed for the silver and copper combined, and a second portion for the silver alone.

VOLTS.	AM- PERES.	TIME. MIN.	
7 2.5	0.5-.07 2	18 25	0.1409 combined weight of Cu and Ag = 99.94 per cent. 0.1268 weight of silver = 90.00 per cent.

If potassium chromate be added to the solution of a copper salt in the presence of ammonium hydroxide and ammonium sulphate, the copper will not be precipitated on passing the current. Under similar conditions silver will be readily and quantitatively deposited. In a liquid containing the two metals with the reagents referred to, a current 0.6 ampere and 2.5 volts precipitated the silver in a very satisfactory form. J. Am. Ch. S., **32**, 1474; Gillett, Jr. phys. Ch., **12**, 26 (1908).

10. From Gold. No successful method has yet been found. See Jr. An. Ch., **6**, 87.

11. From Iron. When the iron is present as a ferrous salt in the mixture of salts, introduce into the solution 3 grams of potassium cyanide, dilute to 100 c.c. with water, heat to 65°, and electrolyze with a current of N.D.₁₀₀ = 0.04 ampere and 2.7 volts. The silver will be fully precipitated in 3 hours, or in a few minutes by use of the *rotating anode*.

The separation of these metals can also be made in nitric acid solution by observing the conditions laid down on pp. 109, 110.

12. From Lead. Consult p. 236, where the separation of lead from silver is described. See also Arth and Nicolas, Ch. N. **88**, 309.

13. From Lithium. See silver from barium and the alkaline earth metals, p. 238.

14. **From Magnesium.** See silver from barium, p. 238.
15. **From Manganese.** See lead from manganese, p. 235.
16. **From Mercury.** There is no known electrolytic method for the separation of these metals. It is true that both can be precipitated from a nitric acid solution, their joint weight be determined, after which the mercury can be expelled by heat and the silver residue be reweighed.
17. **From Molybdenum, Tungsten, and Osmium.** Follow the conditions recommended as satisfactory in the separation of silver from cobalt, p. 239.
18. **From Nickel.** Add 1.5 gram of pure potassium cyanide to the solution containing equal amounts of the metals (0.1–0.2 gram), dilute to 125 c.c. with water, heat to 60°–65°, and electrolyze with a current of $N.D._{100} = 0.02-0.03$ ampere and a pressure of 1.6–2.0 volts. The period of precipitation is usually 3 hours (J. Am. Ch. S., 21, 915).

To reduce the time factor use the *rotating anode*. To the solution of the salts of the metals add 1.5 gram of pure potassium cyanide and electrolyze with a current of $N.D._{100} = 0.4$ to 0.7 ampere and 2.5 volts. The separation will be finished in 20 minutes. To the solution of the two metals add 0.3 c.c. of nitric acid of sp. gr. 1.4, 5 c.c. of ordinary alcohol and electrolyze with a current of $N.D._{100} = 0.1$ ampere and 1.1 volts. Rotate the anode (J. Am. Ch. S., 32, 1472).
19. **From Palladium.** The electrolytic separation of silver from palladium has not yet been made with any satisfaction.
20. **From Platinum.** To the solution of the combined metals add (for 0.2 gram of each metal) 1.25 gram of pure potassium cyanide, dilute to 125 c.c. with water, heat to 70°, and electrolyze with a current of $N.D._{100} = 0.04$ ampere and 2.5 volts.

The precipitation will be complete at the end of 3 hours (J. Am. Ch. S., 21, 913).

To hasten this separation use a *rotating anode* with a current of $N.D._{100} = 0.25$ to 0.05 ampere and 3 volts. Twenty minutes will suffice for the deposition of the silver.

21. From Potassium, the other Alkali Metals, and Alkaline Earth Metals. See the separation from barium, p. 238.

22. From Selenium:—

(a) *In cyanide solution.* Meyer (Z. f. anorg. Ch., 31, 393) pursued a course in the determination of the atomic weight of selenium, in which he electrolyzed silver selenite in cyanide solution. The silver was precipitated free from selenium, so that this method may be regarded as furnishing a satisfactory separation of the two metals. As working conditions were not given by Meyer those used with success in this laboratory will be here introduced:

Add to the solution of the two metals 3 grams of potassium cyanide, heat to $60^{\circ} C.$, and electrolyze with a current of $N.D._{100} = 0.02$ ampere and 2.5 volts. The separation will be finished in 6 hours.

(b) *In nitric acid solution.* Add 1 c.c. of nitric acid (sp. gr. 1.43) to the solution of the metals, heat to $60^{\circ} C.$, and electrolyze with a current of $N.D._{100} = 0.015$ ampere and 1.25 to 2 volts. Time, 3 hours.

23. From Tellurium. In a cyanide solution this separation did not succeed.

Add to the solution of the two metals one cubic centimeter of nitric acid (sp. gr. 1.43), dilute to 150 c.c., heat to $60^{\circ} C.$, and electrolyze with a current of $N.D._{100} = 0.01$ to 0.015 ampere and 1.25 to 2 volts. Time, $3\frac{1}{2}$ hours.

24. From Tin. When tin and silver are present together, digest their sulphides with ammonium sulphide, which

will bring the tin into a proper condition to effect its determination electrolytically (p. 169). Dissolve the insoluble silver sulphide in nitric acid, and after the excess of the latter is expelled, add an excess of potassium cyanide and proceed as directed on p. 111. The silver will be deposited as a dense coating, and may be washed with hot water.

This same course, which is not a strict electrolytic procedure, has also been recommended for the separation of silver when associated with arsenic, antimony, and tin.

25. From Uranium. See aluminium from silver, p. 237.

26. From Zinc. Add 1 gram of pure potassium cyanide to the liquid containing at least 0.1 gram of each metal, dilute to 125 c.c. with water, and electrolyze at 70° with a current of $N.D._{100} = 0.032-0.038$ ampere and 2.76 volts. The silver will be fully precipitated in 3 hours. Treat as described on p. 110 (J. Am. Ch. S., 21, 915).

By using the *rotating anode*, in the presence of 2.5 grams of potassium cyanide, a current of $N.D._{100} = 0.3$ ampere and 3 volts will precipitate the silver in twenty minutes.

GOLD.

Separations of gold from certain metals have been carried out in the electrolytic way with marked success. As they may prove helpful, it was deemed advisable to describe them here in sufficient detail to make them generally applicable.

1. From Antimony. Add 0.5 to 1 gram of tartaric acid to their solution, followed by 3 to 4 grams of pure potassium cyanide; then electrolyze with the conditions given under the separation of gold from copper.

2. From Cadmium:—

In phosphoric acid solution. Add 40 c.c. of disodium hydrogen phosphate (sp. gr. 1.028) and 10 c.c. of phos-

phoric acid (sp. gr. 1.35) to the solution of the metals, dilute to 125 c.c., heat to 60° C., and electrolyze with a current of $N.D._{100}=0.03$ ampere and 1 to 2 volts. Time, 4 hours.

3. From Cobalt.

(a) *In cyanide solution.* In the early experiments made in the separation of these metals some difficulties were encountered, so that it will be necessary to follow the directions given below with the utmost care. After adding 4 grams of pure potassium cyanide to the solution, dilute to 125 c.c., heat to 65°, and electrolyze with a current of $N.D._{100}=0.05-0.08$ ampere and 1.7-2 volts. Before interrupting the current introduce 1 c.c. of a 2 per cent. sodium hydroxide solution and increase the current to 0.10 ampere. The time necessary to effect this separation is usually 6 hours (J. Am. Ch. S., 21, 922).

(b) *In phosphoric acid solution.* Let the total dilution of the solution be about 200 c.c. There should be present 30 c.c. of disodium hydrogen phosphate (sp. gr. 1.028) and 6 c.c. of phosphoric acid (sp. gr. 1.35). Heat to 60° C. Electrolyze with a current of $N.D._{100}=0.03$ to 0.04 ampere and a pressure of from 1 to 2 volts.

4. **From Copper.** The alkaline cyanide solution is best adapted for this separation. To the liquid containing 0.1665 gram of gold and a like amount of copper 4 grams of potassium cyanide were added. The solution was diluted to 250 c.c. with water, heated to 60°-65°, and electrolyzed with a current of $N.D._{100}=0.05-0.08$ ampere and 1.7-1.9 volts. At the expiration of two and one-half hours 0.1667 gram of gold, free from copper, was precipitated. The liquid poured off from the gold, after the addition of an excess of ammonium carbonate, can be acted upon with a

more powerful current and the copper be thus obtained (p. 75). See J. Am. Ch. S., **21**, 921; J. Am. Ch. S., **26**, 1268.

5. From Iron.

(a) *In cyanide solution.* Dissolve pure ferrous ammonium sulphate (=0.1300 gram of iron) in water and run this solution into a solution of three grams of pure potassium cyanide. Next add this potassium ferrocyanide solution to the gold salt, dilute with water to 125 c.c., heat to 65° C., and electrolyze with a current of N.D.₁₀₀=0.36 ampere and 2.3 to 3 volts. Two and one-half hours will serve for the complete precipitation of gold (J. Am. Ch. S., **26**, 1259).

(b) *In phosphoric acid solution.* To the solution containing the two metals add 40 c.c. of disodium hydrogen phosphate (sp. gr. 1.028) and 10 c.c. of phosphoric acid (sp. gr. 1.35), then dilute to 150 c.c., heat to 65° C., and electrolyze with a current of N.D.₁₀₀=0.02 to 0.08 ampere and 1 to 2.7 volts. Five hours will be required for the precipitation (J. Am. Ch. S., **26**, 1266).

6. From Nickel.

(a) *In cyanide solution.* Follow the conditions observed in the separation of gold from cobalt (see above).

(b) *In phosphoric acid solution.* Follow the conditions given for the separation of gold from iron in this electrolyte (see above) (J. Am. Ch. S., **26**, 1268).

7. **From Palladium.** To their solution add 2 grams of pure potassium cyanide, dilute to 150 c.c. with water, heat to 65°, and electrolyze for 5 hours with a current of N.D.₁₀₀=0.03 to 0.06 ampere and 2.5 volts. The gold will be precipitated free from palladium. In using the *rotating anode* with a cyanide electrolyte, containing equal amounts of the two metals, apply a current of two amperes and six

volts. The gold will be precipitated in ten minutes. J. Am. Ch. S., 29, 471.

8. **From Platinum.** Add to the solution, containing equal quantities of the two metals, about 1.5 grams of pure potassium cyanide, dilute to 250 c.c. with water, heat to 70° , and electrolyze for 3 hours with a current of $N.D._{100}=0.01$ ampere and 2.7 volts (J. Am. Ch. S., 21, 923). A current of 2.5 amperes and 6 volts will effect this separation in fifteen minutes if the *rotating anode* be employed. J. Am. Ch. S., 29, 470.

9. **From Zinc:—**

(a) *In cyanide solution.* In this separation the points to be observed are the quantity of potassium cyanide (4 grams), the current density, $N.D._{100}=0.06$ ampere, and the pressure, which should be about 2.6 volts. The dilution and other conditions are similar to those followed in the separation of gold from copper, p. 247 (J. Am. Ch. S., 21, 923).

(b) *In phosphoric acid solution.* To the solution of the metals add 30 c.c. of disodium hydrogen phosphate (sp. gr. 1.028) and 6 c.c. of phosphoric acid (sp. gr. 1.35). Dilute to 150 c.c., heat to 65° C., and electrolyze with a current of $N.D._{100}=0.2$ ampere.

It may be here stated that the conditions given for the separation of gold from copper will serve just as well for the separation of gold from molybdenum, tungsten, and osmium. The conditions observed in the precipitation of gold from a sulphaurate solution (p. 166) can be used with the certainty of good results in the separation of gold from arsenic, molybdenum, and tungsten, while its deposition from a phosphoric acid solution (p. 166) will prove of value in its separation from zinc and cobalt (Am. Ch. Jr., 13, 206).

THE PLATINUM METALS.

In this group of metals separations are not very numerous. Further research is needed in this particular direction. For instance with **platinum** there are lacking separations from aluminium, antimony, arsenic, the alkaline earth metals, bismuth, lead, manganese, molybdenum, selenium, tellurium, thallium, tin, tungsten, uranium and vanadium. Consequently, those from which it has been separated in the electrolytic way are few: zinc, cadmium, iron, nickel and cobalt, in acid solution (with a current of $N.D._{100} = 0.07$ to 0.08 ampere and 1.8 to 2.0 volts), copper (p. 198), gold (p. 249), mercury (p. 222) and silver (p. 244).

Platinum may be separated from iridium in a slightly acidulated solution with a current of $N.D._{100} = 0.05$ ampere and 1.2 volts (Classen).

In the case of **Palladium** the only separations of it seem to be from copper (p. 198), mercury (p. 222), silver and iridium by the method given for its determination on p. 157.

The separations of the metals comprising the platinum group, one from the other, have thus far received scant attention, but from qualitative trials they promise interesting results.

The method given on p. 159 for the precipitation of **Rhodium** has not been applied to effect any separations.

ANTIMONY, ARSENIC, AND TIN.

Under the metals which precede this group will be found the methods that experience has shown are best adapted for their separation from any one member of this group. So far as the latter itself is concerned, much credit is due Classen and his co-laborers for valuable data upon the electrolytic separation of its members.

1. Antimony from Arsenic. The metals, or compounds of the same, are evaporated to dryness with aqua regia, the residue dissolved in 2 to 3 c.c. of water; concentrated sodium hydroxide is added so that there will be 2.5 grams of alkali present in the liquid and then 80 c.c. of sodium sulphide (sp. gr. 1.13-1.15) are introduced and the whole solution is diluted to 150 c.c., temperature 25° - 38° , and electrolyzed with $N.D._{100}=1.5-1.6$ amperes and 2.1 volts (beginning) to 1.45 volts (at end). The time required for the separation of the antimony is usually 6 hours (Z. f. Elektrochem., 1, 291).

Or, to a solution containing 0.1268 gram of antimony and 0.2000 gram of arsenic, add 15 c.c. of sodium sulphide of specific gravity 1.18, three grams of potassium cyanide and water to increase the total volume of liquid to 70 c.c., then apply a current of 6 amperes and 4 volts with the *rotating anode*. The antimony will be completely precipitated in 20 minutes.

2. Antimony from Tin. The sulphides (or residue from a solution of the metals) are placed in a weighed platinum dish and covered with 80 c.c. of sodium sulphide of specific gravity 1.13-1.15, to which are added 2 grams of sodium hydroxide. Dilute to 125 c.c. with water, heat to 57° - 67° , and electrolyze with a current of $N.D._{100}=1.45-1.50$ ampere and 0.9-0.8 volt. The precipitation will be complete at the expiration of 2 hours (Z. f. Elektrochem., 1, 291). Pour off the liquid into a second dish. Treat the deposit of antimony as previously directed (p. 174). To prepare the tin solution for electrolysis, proceed as described (p. 170) for the conversion of the sodium into ammonium sulphide (Ber., 17, 2245; 18, 1110).

This separation has not always given the results that were confidently expected. There are disturbing features

connected with it. It is not certain that these have been absolutely eliminated, although strenuous efforts have been put forth to arrive at such a result. Very recently Ost and Klapproth (*Z. f. anorg. Ch.*, 1900, p. 827) conducted experiments in a cell provided with a diaphragm (p. 176). These demonstrated that by using a concentrated sodium sulphide solution the current, as a rule, mainly decomposes the sodium sulphide, and the antimony, if the bath pressure is low, does not participate in the electrolysis. It is precipitated as a secondary product by the sodium ion. When the pressure is great and the antimony salt assists in conducting the current, then the antimony wanders in the form of a complex anion, SbS_4 , to the anode. Disturbances also arise from the comingling of the anode and cathode liquids, so that these investigators have worked out the following piece of apparatus, to be used in this separation, which in their hands has yielded very satisfactory results. The sketch (Fig. 35) gives a perfect idea of their scheme. *a* is a low beaker; the cylindrical diaphragm (a Pukall porous cell), *b*, stands in it. The anode is a rod of carbon, *c*, placed within the diaphragm-cell, while a bent sheet of platinum or a platinum gauze, *d*, serves as cathode. The beaker and cell are covered with suitable cover-glasses. The diaphragm-cell above the liquid is covered with a suitable rubber ring, *e*, so that the drops of liquid falling from the cover-glass are returned to the cathode chamber. The diaphragm, thoroughly cleansed, should always be preserved under water. The anode liquor should be introduced into the diaphragm-cell some time before the electrolysis begins and the apparatus should not be connected up until this liquor has penetrated through the walls of the diaphragm. During the electrolysis the level of the anode solution should stand from 0.5 to 1 cm. higher than that of the cathode solution. The anode chamber contains from 40 to 50 c.c., and the cathode

chamber 150 c.c. The total volume of the electrolytes is about 150 c.c. The available surface of the cathodes equals 1 sq. dm.

To illustrate the practical working of this idea, several results taken from Klapproth's doctoral thesis (*Die Fällung*

FIG. 35.

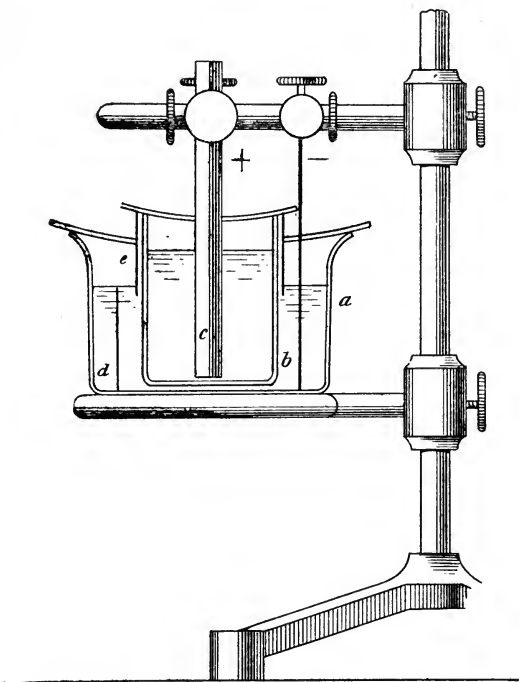

des Zinns und seine Trennung vom Antimon durch Elektrolyse, Hannover, 1901) may be incorporated (see p. 254).

The solution, freed from antimony, can now be changed to one suitable for the precipitation of the tin by digesting it with ammonium sulphate (p. 170). If this is to be done in the absence of the diaphragm, then the latter must be removed from the solution, placed over the cathode beaker,

and be washed for one-half hour, by allowing water to run through it. The liquid is later concentrated and electrolyzed (see p. 174).

SEPARATION OF ANTIMONY AND TIN. DIAPHRAGM AND CARBON ANODE.

SOLUTION OF NINETY C.C. IN CATHODE CHAMBER.			SOLUTION OF FIFTY C.C. IN ANODE CHAMBER.	TEMPERATURE.	CURRENT STRENGTH, IN AMPERES.	PRESSURE, IN VOLTS.	ANTIMONY FOUND, IN GRAMS.	DURATION OF PRECIPITATION (HOURS).
Na ₂ S, IN C.C.	Sb, IN GRAMS.	Sn, IN GRAMS.						
40	0.1500	0.2500	30 Na ₂ S	20°	0.08	0.9	0.1505	16
35	0.1500	0.2500	30 Na ₂ S	20°	0.19	1.10	0.1446	7
60	0.1500	0.5000	{ 20(NH ₄) ₂ S 30(NH ₄) ₂ SO ₄ }	20°	0.2	0.5	0.1500	16
40	0.3000	0.2500	{ 20(NH ₄) ₂ S 30(NH ₄) ₂ SO ₄ }	20°	0.15	1.2	0.2990	7
50	0.1500	0.2500	{ 20(NH ₄) ₂ S 30(NH ₄) ₂ SO ₄ }	20°	0.5	1.0	0.1495	16

But the tin may be estimated without removing the diaphragm. To this end the cathode liquor is reduced to a volume of 40 c.c. and the anode solution is renewed. The precipitation of the tin is then made at 70°. As much as 0.25 gram of the metal will be precipitated in from 2 to 3 hours. The pressure should not exceed 2 volts. J. Wolf. Dissertation, Dresden (1908).

When antimony, arsenic, and tin are present together, expel the arsenic from their solution by the Fischer-Hufschmidt method (Ber., 18, 1110), and separate the antimony from the tin as already described on page 251. See also Fischer, Z. f. anorg. Ch., 42, 363-417.

In general analysis phosphoric acid is frequently precipitated as tin phosphate. The latter, of course, contains tin oxide. Dissolve the precipitate in ammonium sulphide. On electrolyzing the solution the tin will be precipitated,

and the filtrate will contain all of the phosphoric acid; this can be estimated in the usual way (Classen). By observing this suggestion the determination of the phosphoric acid in a separate portion of the material will not be required.

Tin from Manganese. Dissolve 0.5 gram of tin in a solution of bromine in hydrochloric acid, neutralize with ammonium hydroxide, add the solution of manganese sulphate and introduce this mixture into 25 c.c. of a saturated ammonium oxalate solution. Next add 100 c.c. of a saturated oxalic acid solution and electrolyze with a current of one ampere per 1 sq. dm. and a pressure of 2.5 volts. The tin will be precipitated in satisfactory form. Puschin, *Ch. Z.*, 30, 572; *Z. f. Elektrochem.*, 13, 153.

IRON, MANGANESE, NICKEL, ZINC, COBALT, ALUMINIUM, CHROMIUM, AND PHOSPHORIC ACID.

Electrolytic methods for the separation of these metals are neither so numerous nor so thoroughly worked out as with the metals already considered. Their separation from the heavy metals has been outlined under the same, and it only remains to describe the courses which may be pursued with this group of metals when present together.

1. Iron from Aluminium. Add sufficient ammonium oxalate to the solution of the salts of the metals (preferably not chlorides) so that it will contain from 2 to 3 grams of oxalate for each 0.1 gram of metal. Dilute to 175 c.c., heat to 40°, and electrolyze with $N.D._{100} = 1.95-1.6$ amperes and 4.3-4.4 volts. The iron will be precipitated in two and one-half hours (*Ber.*, 18, 1795; 27, 2060; *Z. f. Elektrochem.*, 1, 292). It is not advisable to allow the current to act longer than is necessary for the reduction of the iron. Towards the end of the electrolysis aluminium

hydroxide is apt to separate and will coat the iron deposit. When the latter is dry, this adhering material can be removed with a handkerchief. The aluminium must be determined gravimetrically. The separation of aluminium hydroxide can be avoided if ammonium or potassium tartrate or citrate (1 gram) be added to the solution of the two metals, and it be heated to 60°, then electrolyzed with $N.D._{100} = 1$ ampere and 4-5 volts. It is true that the iron will probably contain small amounts of carbon. These will not be excessive and will not affect the results seriously. See p. 141. Consult Hollard and Bertiaux, *C. r.*, 136, 1266.

Drown and McKenna have endeavored to utilize the method described on p. 145 for the separation of iron from other elements. The conditions favorable for the deposition of the iron they found unfavorable for its separation from manganese. They experienced no difficulty in separating iron from aluminium or iron from phosphoric acid. It is expected that the process will give equally good results in the separation of iron and some other metals from titanium, zirconium, columbium, and tantalum (Wolcott Gibbs, *Am. Ch. Jr.*, 13, 571; see also pp. 27, 61). To determine iron in the presence of aluminium in steel they recommend the following procedure:

“Dissolve 5-10 grams of iron or steel in sulphuric acid, evaporate until white fumes of sulphuric anhydride begin to come off, add water, heat until all the iron is in solution, filter off the silica and carbon, and wash with water acidulated with sulphuric acid. Make the filtrate nearly neutral with ammonia, and add to the beaker in which the electrolysis is made, about 100 times as much mercury as the weight of iron or steel taken. The volume of the solution should be from 300 to 500 c.c. Connect with battery or dynamo in such a way that about 2 amperes

may pass through the solution over night. . . . When the solution gives no test for iron, it is removed from the beaker with a pipette while the current is still passing." The aluminium is determined in this filtrate (Jr. An. Ch., 5, 627). For the separation of iron from titanium and aluminium consult also Magri and Ercolini, Atti. R. Accad. dei Lincei, Roma [5], 16, I. 331. Iron from titanium, Magri and Ercolini, *Gazetta Chimica Italiana*, 37, 179 (1907).

By modifying the preceding scheme in accordance with the outline given on p. 61, and observing the steps and precautions detailed under copper, p. 82, iron may be easily separated quantitatively, with the aid of a mercury cathode.

From Vanadium. The details are best given in examples, so that a tabulated series of results may be here introduced:

	IRON PRESENT IN GRAMS.	IRON FOUND IN GRAMS.	VANADIUM PRESENT IN GRAMS.	SULPHURIC ACID (SP. G. 1.832) PRESENT IN DROPS.	TIME HOURS.	CONDITIONS.			
						AMPERES.	VOLTS.	AMPERES.	VOLTS.
1	0.1056	0.1054	0.1002	12	7	0.4	7	1	8.5
2	0.1056	0.1051	0.1002	13	14	0.6	7	1	9
3	0.2112	0.2113	0.0200	5	14	0.3	7	1	7.5
4	0.2112	0.2112	0.0200	5	14	0.4	7	1	7

The dilution of solution in each of these trials equaled 20 cubic centimeters.

From Beryllium. From the readiness with which iron may be separated from aluminium with the aid of a mercury cathode it was reasonable to suppose that its separation from beryllium could be made without difficulty. The series given in the appended table sets forth the conditions of successful operation. They appear just as they were carried out:

	IRON PRESENT IN GRAMS.	IRON FOUND IN GRAMS.	BERYLLIUM OXIDE PRESENT IN GRAMS.	BERYLLIUM OXIDE FOUND IN GRAMS.	SULPHURIC ACID (SP. G. 1.332) PRESENT IN DROPS.	TIME. HOURS.	CONDITIONS.			
							AMPERES.	VOLTS.	AMPERES.	VOLTS.
1	0.1056	0.1057	0.0818	0.0821	2	7	0.5	7	0.5	6.5
2	0.1056	0.1059	0.0818	0.0820	2	14	0.5	7	0.5	6.5
3	0.0105	0.0105	0.1636	0.1633	2	4½	0.6	8	0.6	8
4	0.0200	0.0208	0.1636	0.1630	2	14	0.6	8	0.6	8
5	0.2112	0.2113	0.0082	0.0082	2	14	0.4	6.5	1.4	7
6	0.2112	0.2112	0.0082	0.0083	2	14	0.4	6.5	1.4	7

See J. Am. Chem. S., 26, 1128.

After discovering the rapidity with which metals were deposited in a *mercury cathode with the help of a rotating anode* (p. 82) it was proposed to try out the separation of iron in this way from other metals with which it is often associated and from some of which by ordinary gravimetric methods it is separated with difficulty. The speed of the anode was 600 revolutions per minute. The metals were present either as sulphates or nitrates. The working conditions are sufficiently indicated in the appended experiments.

a. IRON FROM URANIUM.

URANYL SULPHATE. GRAM.	IRON PRESENT. GRAM.	VOLUME OF SOLUTION. C.C.	SULPHURIC ACID IN DROPS. (30 = 1 C.C.).	CURRENT. AMPERES.	VOLTS.	TIME. MINUTES.	IRON FOUND. GRAM.	ERROR. GRAM.
0.2	0.1777	7	2	3-5	7-5	15	0.1777	—
0.1	0.1777	6	2	2-5	7-5	15	0.1772	—0.0005
0.2	0.1777	7	3	2.5-5	7-5	15	0.1769	—0.0008
0.2	0.1777	7	2	2.5-3.5	7-5	15	0.1775	—0.0002

b. IRON FROM ALUMINIUM.

ALUMINIUM SULPHATE. GRAM.	IRON PRESENT. GRAM.	VOLUME OF SOLUTION. C.C.	SULPHURIC ACID IN DROPS. (30 = 1 C.C.).	CURRENT. AMPERES.	VOLTS.	TIME. MINUTES.	IRON FOUND. GRAM.	ERROR. GRAM.
0.2	0.1777	7	2	2.5	9.7	15	0.1777	—
0.2	0.1777	7	0	2.4	9.7	15	0.1782	+0.0005
0.2	0.1777	7	2	2.5	9.7	15	0.1781	+0.0004
0.3	0.1777	8	2	2.45	7.6	15	0.1782	+0.0005

c. IRON FROM THORIUM.

THORIUM NITRATE. GRAM.	IRON PRESENT. GRAM.	VOLUME. C.C.	SULPHURIC ACID IN DROPS. (30 = 1 C.C.).	CURRENT. AMPERES.	VOLTS.	TIME. MINUTES.	IRON FOUND. GRAM.	ERROR. GRAM.
0.2	0.1777	7	2	2.4	7.6	15	0.1777	—
0.2	0.1777	7	2	3.5	6.5	15	0.1777	—
0.3	0.1777	8	2	3.4	7.5	15	0.1777	—
0.2	0.1777	7	2	3.4	7.5	15	0.1776	-0.0001

d. IRON FROM LANTHANUM.

LANTHANUM SULPHATE. GRAM.	IRON PRESENT. GRAM.	VOLUME. C.C.	SULPHURIC ACID IN DROPS. (30 = 1 C.C.).	CURRENT. AMPERES.	VOLTS.	TIME. MINUTES.	IRON FOUND. GRAM.	ERROR. GRAM.
0.2	0.1220	10	2	2.4	8.6	15	0.1221	+0.0001
0.15	0.1220	10	2	2.4	8.6	15	0.1226	+0.0006
0.25	0.1220	10	2	2.4	8.6	15	0.1226	+0.0006

e. IRON FROM PRASEODYMIUM.

PRASEODYMIUM SULPHATE. GRAM.	IRON PRESENT. GRAM.	VOLUME. C.C.	SULPHURIC ACID IN DROPS. (30 = 1 C.C.).	CURRENT. AMPERES.	VOLTS.	TIME. MINUTES.	IRON FOUND. GRAM.	ERROR. GRAM.
0.25	0.1235	7	2	2.4	8.5	20	0.1240	+0.0005
0.3	0.1235	8	2	3.5	9.6	20	0.1234	-0.0001
0.3	0.1235	8	2	2.4	8.5	20	0.1229	-0.0006
0.25	0.1235	7	2	2.4	8.5	20	0.1230	-0.0005

f. IRON FROM NEODYMIUM.

NEODYMIUM SULPHATE. GRAM.	IRON PRESENT. GRAM.	VOLUME. C.C.	SULPHURIC ACID IN DROPS. (30 = 1 C.C.).	CURRENT. AMPERES.	VOLTS.	TIME. MINUTES.	IRON FOUND. GRAM.	ERROR. GRAM.
0.16	0.1235	7	2	3.4	7.5	20	0.1242	+0.0007
0.24	0.1235	8	2	3.5	9.5	20	0.1236	+0.0001
0.24	0.1235	8	2	3.5	9.7	20	0.1237	+0.0002
0.16	0.1235	7	2	3.5	9.5	20	0.1237	+0.0002

g. IRON FROM CERIUM.

CERIUM SULPHATE. GRAM.	IRON PRESENT. GRAM.	VOLUME. C.C.	SULPHURIC ACID IN DROPS. (30 = 1 C.C.).	CURRENT. AMPERES.	VOLTS.	TIME. MINUTES.	IRON FOUND. GRAM.	ERROR. GRAM.
0.12	0.1235	8	2	2.4	9.6	20	0.1237	+0.0002
0.24	0.1235	9	2	2.4	9.6	20	0.1236	+0.0001
0.36	0.1235	10	0	2.5	10.7	25	0.1230	-0.0005

h. IRON FROM ZIRCONIUM.

ZIRCONIUM SULPHATE. GRAM.	IRON PRESENT. GRAM.	VOLUME. C.C.	SULPHURIC ACID IN DROPS. (30 = 1 C.C.).	CURRENT. AMPERES.	VOLTS.	TIME. MINUTES.	IRON FOUND. GRAM.	ERROR. GRAM.
0.2	0.1235	7	0	2-4	7-5	20	0.1238	+0.0003
0.3	0.1235	8	1	2-4	7-5	20	0.1230	+0.0005
0.5	0.1235	10	2	2-5	6-5	25	0.1238	+0.0003

The conditions under thorium will answer for the separation of iron from titanium and from yttrium.

J. Am. Ch. S., 25, 888; *ibid.*, 27, 1547.

- From Chromium.** They can be separated in oxalate solution with conditions like those given above for the separation of iron from aluminium, the only difference being that the temperature should be about 65° (Z. f. Elektrochem., 1, 292). The chromium during the electrolysis is converted into chromate. It must be determined gravimetrically. The second course, tartrate or citrate solution, also lends itself well to this separation. The requisites are given above under iron and aluminium. It may be added here that just as iron is separated in tartrate or citrate solution from aluminium and chromium, so can it also be separated from titanium.
- From Cobalt.** Classen (Ber., 27, 2060) adds about 8 grams of ammonium oxalate to the solution of the metals, dilutes with water to 120 c.c., heats to 65°-70°, and electrolyzes with $N.D._{100} = 1.6-2.0$ amperes and electrode pressure of 3.0-3.6 volts. The time required for complete deposition varies from 2 to 4 hours. The metals are precipitated together, their combined weight ascertained, then they are dissolved in acid, and the quantity of iron is found by titration. The cobalt is obtained by difference.

Vortmann suggests adding 3 to 6 grams of ammonium sulphate and a moderate excess of ammonium hydroxide to the solution of the metals, then electrolyzing with a current of $N.D._{100} = 0.4-0.8$ ampere and 4-5 volts. He remarks that by contact with the ferric hydroxide the deposit of cobalt will contain traces of iron, which can be fully eliminated by a second precipitation. (See iron from nickel.)

4. **From Manganese.** In considering this separation it should be remembered that objections have repeatedly been offered to the suggestion of Classen (Ber., 18, 1787); hence to obtain results at all satisfactory it is advisable to carry out the separation *exactly* as given by this chemist: "If a solution of the double oxalates of iron and manganese is subjected to electrolysis, without the previous addition of a great excess of ammonium oxalate . . . it is impossible to obtain a quantitative separation of the two metals, because the manganese dioxide carries down with it considerable quantities of ferric hydroxide. The complete separation of the metals is possible only when the separation of the dioxide is delayed till most of the iron is precipitated." The electrolysis in the *cold* is not favorable; the large amount of ammonium carbonate, or ammonia formed in the decomposition of the excessive ammonium oxalate, dissolves the precipitated dioxide. "The rapid dissociation of ammonium oxalate when heated, however, gives a simple means of delaying, or entirely preventing, the formation of a manganese precipitate during the electrolysis." The solution containing the two metals is treated with 8 to 10 grams of ammonium oxalate and while hot (70°) is acted upon with a current of $N.D._{100} = 0.5$ ampere and 3.1-3.8 volts. Treat the iron deposit as directed on p. 143. Boil the liquid, poured off from the iron, with sodium hydroxide,

to decompose the ammonium carbonate present, after which add sodium carbonate and a little sodium hypochlorite. The manganese is precipitated as dioxide, and after solution in hydrochloric acid is finally weighed as pyrophosphate.

Classen mentions that the method affords good results if the manganese content is not too high. In the analysis of ferromanganese, for example, it possesses no practical value (Ber., 18, 1787). Engels has tried to use the plan he describes for the deposition of manganese (p. 139) in effecting the separation of the latter from iron (Z. f. Elektrochem., 2, 414), but it has been observed that while the manganese was completely deposited as dioxide, it invariably contained as much as 0.02 gram of iron. See Köster, Ber., 26, 2746; Hollard and Bertiaux, C. r., 136, 1266.

Scholl, working in this laboratory, separated iron and manganese and determined them simultaneously by the following procedure: Ten cubic centimeters of a manganese sulphate solution (= 0.0988 gram of manganese) were introduced into a roughened platinum dish. To this were added 10 c.c. of a ferric ammonium sulphate solution (= 0.0996 gram of iron), 5 c.c. of formic acid, sp. gr. 1.06, and 10 c.c. of ammonium acetate. A basket electrode (the cathode) was then suspended in the liquid and a current of $N.D._{100} = 1.1$ amperes and 3.9 volts was allowed to act for five hours. The precipitation of each metal was complete, the manganese of course separating as dioxide (J. Am. Ch. S., 25, 1045).

- 5. From Nickel.** Classen deposits nickel and iron together (same as cobalt and iron) as an alloy, which is weighed, then dissolved in concentrated hydrochloric acid, the iron oxidized with hydrogen peroxide, and the ferric solution titrated with a stannous chloride solution. The current may vary from 1.75 to 2.2 amperes and the voltage from

3.4 to 4.0. The temperature of the liquid is usually 65° – 70° . Two hours will be sufficient time for the precipitation of 0.2 gram of the combined metals.

Under iron from cobalt mention was made of a method which can be pursued in separating the metals now under discussion. To repeat, it consists in oxidizing the iron with bromine, then introducing into the solution from 3 to 6 grams of ammonium sulphate and a moderate excess of ammonium hydroxide. From this solution the nickel will be deposited in from 2 to 3 hours, with a current of $N.D._{100} = 0.4$ – 0.8 ampere. As in the case of the cobalt, traces of iron will appear in the nickel. This occlusion of iron, so to speak, has become a subject of discussion among those using electrolytic methods. Neumann (*Ch. Z.*, **22**, 731) remarks that it has tacitly been understood that the nickel carries down no iron with it. Indeed, Engels (Thesis, Bern) claims to have obtained perfectly correct results. Vortmann, as indicated, and also Ducru (*Ch. Z.*, **21**, 780; *C. r.*, **125**, 436; *B. s. Ch. Paris*, **17**, 1881) recommend the solution of the nickel and the determination of any iron present. So well satisfied is Ducru that he employs this method for the estimation of nickel in steel, asserting that the amount of enclosed iron is fairly constant (varying between 1 and 2 mg.), and that for technical or commercial purposes it may be ignored. Neumann, on the other hand, maintains the absolute necessity of determining the amount of iron co-precipitated. In the analysis of nickel steel and nickel matte he proceeds as follows:—

Dissolve the substance in dilute sulphuric acid, and after a brief period introduce hydrogen peroxide into the solution to oxidize the carbon and the iron, thus obtaining a clear, yellow solution. Now add ammonium sulphate and ammonium hydroxide, boil and continue the addition of ammonium hydroxide to an excess, then dilute to a

definite volume. Filter out 100 c.c. of this solution, mix with it ammonium sulphate and ammonium hydroxide, dilute to 175–200 c.c., and electrolyze the hot liquid with $N.D._{100} = 1-2$ amperes and 3.4–3.8 volts. The electrolysis will be finished at the expiration of from $1\frac{1}{2}$ to 2 hours. See also J. Am. Ch. S., **32**, 1473.

For another method by Vortmann applicable here, see zinc from nickel in the presence of Rochelle salt (p. 268).

6. **From Phosphoric Acid.** If the iron has been precipitated from an oxalate solution (p. 143), from a citrate solution, or from an ammoniacal tartrate solution, the liquids poured off from the iron deposit will contain the phosphoric acid, which can then be removed as ammonium magnesium phosphate. Or, if the iron phosphate be dissolved in sulphuric acid the iron may be deposited in a mercury cathode, using at the time a rotating anode (see p. 146).
7. **From Titanium.** The method described on p. 146, and also p. 261, with the conditions given there, will answer perfectly in making this separation.
8. **From Uranium.** (Ber., **14**, 2771; **18**, 2483.) In making this separation, follow the directions outlined on p. 255 for the separation of iron from aluminium. The uranium is precipitated in the form of hydroxide. The separation with the use of the *mercury cathode* and *rotating anode* (p. 258) is decidedly preferable.
9. **From Zinc.** Add to the solution of the metals 1–3 c.c. of a solution of potassium oxalate (1 : 3) and 3 to 4 grams of ammonium oxalate and electrolyze the liquid with a current of $N.D._{100} = 1$ to 1.2 amperes. The zinc is deposited first, and no difficulty is experienced, providing its quantity is less than one-third that of the iron present. Classen provides for this condition by adding a weighed amount of

pure ferrous ammonium sulphate in excess. Vortmann (M. f. Ch., 14, 536) suggests two methods:—

(a) Add potassium cyanide to the solution of the metals until the precipitate formed at first has dissolved, then introduce sodium hydroxide. The iron is present in the solution as ferrocyanide which, in the presence of free alkali, is not decomposed by the current. Avoid too large an excess of potassium cyanide, as it retards the separation of the zinc. The current should be $N.D._{100} = 0.3-0.6$ ampere.

(b) Several grams of Rochelle salt are introduced into the solution of the metals and then an excess of 10-20 per cent. sodium hydroxide, after which the electrolysis is conducted at $50^{\circ}-60^{\circ}$ with a current of $N.D._{100} = 0.07-0.1$ ampere and an electrode pressure of 2 volts.

1. **Cobalt from Manganese.** The course generally recommended for this separation is precisely like that given for the separation of iron from manganese. Owing to the great tendency of the manganese, toward the close of the decomposition, to separate out as dioxide which settles on the cobalt deposit, the method can hardly be regarded as being accurate.
2. **From Nickel.** To the acetic acid solution of the metals add 10 grams of ammonium sulphocyanide, 3 grams of urea, and from 3 to 6 c.c. of ammonium hydroxide to neutralize the excess of acid. Dilute the solution to 300 to 350 c.c. and electrolyze with a pressure of not more than one volt and 0.8 ampere at $70^{\circ}-80^{\circ}$ C. The time of precipitation is one and one-half hours. Nickel and sulphur pass to the cathode, while the cobalt remains unprecipitated. The nickel should be dissolved in acid and reprecipitated according to the method described on p. 130, to obtain it pure. The liquid poured off from the first nickel deposit should be evaporated to dryness several times with nitric acid, the

residue taken up in water, and the solution treated as directed on p. 137 (Balachowsky, C. r., 132, 1492: also M. f. Ch., 14, 548).

Alvarez (Am. chim. anal. appl. 15, 169) recommends the following course in separating nickel and cobalt: Add potassium cyanide to salts of these metals dissolved in cold water recently boiled and saturated at 0° with sulphur dioxide, forming a yellow nickel cobalto-cyanide, $\text{Ni}_2\text{Co}(\text{CN})_6$, becoming green after washing and drying. Dissolve 0.5 gram of this salt in 100 c.c. of water, and add 40 c.c. of ammonium hydroxide of sp. gr. 0.927 and 5 grams of ammonium sulphate. Electrolyze the solution with a current of $\text{N.D.}_{100}=4$ amperes and 3.7 to 4 volts. The nickel will be precipitated in a brilliant, adherent form. (Experiments in this laboratory did not yield a satisfactory result.) And Bruylants (Am. Soc. Chim. belg. 24, 367) contends that the method does not give the separation claimed for it.

To separate nickel from aluminium, magnesium and the alkaline earths add ammonium hydroxide and ammonium nitrate to the electrolyte which is introduced into a small beaker, a gauze cathode being so bent that there is a clearance of about 5 mm. between it and the anode, and about the same distance between it and the beaker. The weight of the anode is 15 grams and of the cathode 5 grams. (Jr. Am. Ch. Soc., 32, 1473.)

- 3. From Zinc.** Add several grams of Rochelle salt and an excess of a dilute sodium hydroxide solution to the liquid containing the metals. Warm to 65° and electrolyze with $\text{N.D.}_{100}=0.3-0.6$ ampere and 2 volts. Usually there is a deposit upon the anode, hence it is advisable to previously weigh the latter and again at 110° after the precipitation is complete (Elektrochem. Z., 1, 7).

For the separation of cobalt from uranium, using the mercury cup, see the separation of zinc from uranium.

For the peculiar behavior of cobalt in the presence of chromium, ammonium hydroxide and ammonium sulphate read *J. Am. Ch. S.*, **32**, 1473.

1. **Nickel from Manganese.** What was said of the separation of cobalt from manganese applies here in every particular.

For the separation of nickel from aluminium, titanium and the rare earths consult Benner & Hartmann, *J. Am. Ch. S.*, **32**, 1632. See also *J. Am. Ch. S.*, **32**, 1473.

2. From Zinc:—

1. Add 4 to 6 grams of Rochelle salt to the solution of the two metals, then a concentrated solution of sodium hydroxide. Electrolyze the mixture with a current of $N.D._{100} = 0.3-0.6$ ampere. The precipitation of the zinc will be finished in a period of from 2 to 4 hours. Pour off the alkaline liquid, wash the zinc deposit with water and alcohol; dry at $100^{\circ} C$. *J. Am. Ch. S.*, **32**, 1472.
2. Add 10 grams of ammonium sulphate, 5 grams of magnesium sulphate, 5 c.c. of a saturated solution of sulphurous acid and an excess of 25 c.c. of ammonia (sp. gr. 0.924) to the solution containing the two metals as sulphates; dilute to 300 c.c. and electrolyze at 90° with a current of 0.1 ampere. At the expiration of four hours one to two cubic centimeters of the liquid should not turn black on the addition of ammonium sulphhydrate. Continue the electrolysis for an hour longer. *Ch. Z.*, **27**, 1229; *Ch. Z.*, **28**, 645; *C. r.*, **137**, 853; *ibid.*, **138**, 1605. Fischer, *Ch. Z.*, **32**, 185.

This method proposed by Hollard and Bertiaux (*Bull. S. Ch.*, **31**, 102) has been further studied by Thiel and Windelschmidt (*Z. ang. Ch.* **20**, 1137), who found the

nickel invariably contaminated with sulphur. Foerster and Treadwell have confirmed this observation (*Z. f. Elektroch.* (1908), Heft 8; Foerster and Blankenberg, *Z. f. Elektroch.*, **13**, 563).

Puschin and Trechzinsky outline a method in the *Z. f. angew. Ch.*, **17**, 892, for the separation of tin from nickel, which may be regarded as worthy of some consideration, although it in no wise is superior to the ordinary course of analysis.

Consult *J. Am. Ch. S.*, **32**, 1473, on the separation of nickel from chromium, and for its separation from uranium in a mercury cup, in the separation of zinc from uranium.

- 1. Zinc from Manganese.** A solution contained 0.5074 gram of zinc sulphate and 0.1634 gram of manganese sulphate. To it were added 5 grams of ammonium lactate, 0.75 gram of lactic acid, and 2 grams of ammonium sulphate. It was diluted to 200 c.c. and electrolyzed at 20° – 25° C. with a current of $N.D._{100} = 0.24$ – 0.26 ampere and 3.7–3.9 volts. In 4 hours 22.786 per cent. of zinc was found, while theory required 22.78 per cent. (*Riderer, J. Am. Ch. S.*, **27**, 789).

Scholl recommends adding to the solution of the two metals in the form of sulphates, 10 c.c. of formic acid of sp. gr. 1.06 and 5 c.c. of an ammonium formate solution, then electrolyzing with a current of 1 ampere and 5.4 volts, using a sand-blasted dish as anode and a basket shaped cathode. Ten hours are usually required for the separation as the electrodes are stationary.

Zinc may be easily separated from uranium by using the rotating anode and mercury cathode. To their solution in the cup (p. 63) add 0.5 c.c. of concentrated sulphuric acid and electrolyze with a current of 3.5 amperes and a pressure of 5 volts. The zinc will be fully precipitated in fifteen minutes (*J. Am. Ch. S.*, **32**, 1477).

The writer would recommend the following course in separating the metals of this group: Separate the iron from the manganese, zinc, nickel, and cobalt, by precipitation with barium carbonate. Dissolve the iron precipitate in citric acid, and electrolyze the solution according to the directions given upon p. 143. The filtrate, containing the zinc, manganese, nickel, and cobalt, together with a little barium salt, is carefully treated with just sufficient dilute sulphuric acid to remove the barium. After filtering, electrolyze the filtrate in a platinum dish, connected with the anode of a battery, with a current of 0.3-0.5 ampere. A weighed piece of platinum foil will answer for the cathode. The manganese is deposited as dioxide (p. 138); the other metals remain dissolved and can only be separated by one of the usual gravimetric methods; or perhaps the suggestion of Vortmann (p. 268), for the separation of zinc from nickel and cobalt, would be applicable here, and these two might then be separated as outlined on p. 268. This course proved quite satisfactory in the analysis of the mineral Franklinite, where, after having obtained the iron and manganese as described, the zinc was also determined electrolytically in the liquid poured off from the manganese deposit. If the solution containing these two metals be very slightly acid with sulphuric acid, they can be precipitated simultaneously—the zinc at the cathode, and manganese dioxide at the anode. For the separation of zinc from aluminium and titanium, see Benner and Hartmann, *J. Am. Ch. S.*, **32**, 1634.

URANIUM.

Smith has called attention to the separation of uranium in the electrolytic way from the alkali metals and from barium (p. 151). It seemed desirable to amplify the suggestion; hence the presentation of the results given below. It may be said here, that in attempting to separate uranium from

nickel and cobalt no satisfaction could be obtained, so that eventually that particular line of experiment was abandoned. During the precipitation of the urano-uranyl hydrate the dish should be well covered so that as little evaporation as possible occurs. It was observed that in case of evaporation there was danger of other salts separating upon the exposed metal, and on refilling with water the uranium precipitate was apt to enclose the same and thus carry with it a slight impurity. This precaution is especially necessary in the separation from zinc (J. Am. Ch. S., 23, 608).

1. FROM BARIUM (ACETATES).

	U ₃ O ₈ PRESENT, IN GRAMS.	BARIUM PRESENT, IN GRAMS.	TWENTY-NINE PER CENT. FREE ACETIC ACID. C.C.	DILUTION. C.C.	TEMPERATURE. °C.	CURRENT.	VOLTS.	TIME. HOURS.	U ₃ O ₈ FOUND, IN GRAMS.	ERROR, IN GRAMS.
1	0.1116	0.11	0.5	125	70	N.D. _{.107} = 0.02 A	2	5½	0.1119	+0.0003
2	0.1116	0.11	0.5	125	70	N.D. _{.107} = 0.04 A	8	5½	0.1117	+0.0001
3	0.1116	0.11	0.2	125	70	N.D. _{.107} = 0.1 A	4.5	4	0.1117	+0.0001

2. FROM CALCIUM (ACETATES).

	U ₃ O ₈ PRESENT, IN GRAMS.	CALCIUM PRESENT, IN GRAMS.	TWENTY-NINE PER CENT. FREE ACETIC ACID. C.C.	DILUTION. C.C.	TEMPERATURE. °C.	CURRENT.	VOLTS.	TIME. HOURS.	U ₃ O ₈ FOUND, IN GRAMS.	ERROR, IN GRAMS.
1	0.1116	0.1	0.2	125	70	N.D. _{.107} = 0.025 A	2.25	6½	0.1113	-0.0033
2	0.1116	0.1	0.2	125	70	N.D. _{.107} = 0.04 A	2.2	5½	0.1114	-0.0002
3	0.1116	0.1	0.2	125	70	N.D. _{.107} = 0.05 A	2.25	4¾	0.1113	-0.0001
4	0.1116	0.1	0.2	125	70	N.D. _{.107} = 0.025 A	2.0	4¾	0.1115	-0.0000

3. FROM MAGNESIUM (ACETATES).

	U ₃ O ₈ PRESENT, IN GRAMS.	MAGNESIUM PRESENT, IN GRAMS.	TWENTY-NINE PER CENT. FREE ACETIC ACID. C.C.	DILUTION. C.C.	TEMPERATURE. °C.	CURRENT.	VOLTS.	TIME. HOURS.	U ₃ O ₈ FOUND, IN GRAMS.	ERROR, IN GRAMS.
1	0.1116	0.1	0.1	125	70	N.D. _{.107} = 0.026 A	2.22	6	0.1115	-0.0001
2	0.1102	0.1	0.1	125	70	N.D. _{.107} = 0.05 A	2.25	5¼	0.1104	+0.0002
3	0.1120	0.1	0.1	125	70	N.D. _{.107} = 0.15 A	4.0	4	0.1119	-0.0001

4. FROM ZINC (ACETATES).

	U ₃ O ₈ PRESENT, IN GRAMS.	ZINC PRESENT, IN GRAMS.	TWENTY-NINE PER CENT. FREE ACETIC ACID. C.C.	DILUTION. C.C.	TEMPERATURE. °C.	CURRENT.	VOLTS.	TIME. HOURS.	U ₃ O ₈ FOUND, IN GRAMS.	ERROR, IN GRAMS.
1	0.1120	0.1	0.1	125	70	N.D. _{.107} = 0.021 A	2.25	6	0.1120	—
2	0.1102	0.2	0.2	125	70	N.D. _{.107} = 0.017 A	2.25	6	0.1099	-0.0003
3	0.1102	0.1	0.1	125	70	N.D. _{.107} = 0.02 A	2.2	6	0.1100	-0.0002
4	0.1102	0.1	0.1	125	75	N.D. _{.107} = 0.025 A	4.4	4½	0.1103	+0.0001
5	0.1102	0.15	0.2	125	75	N.D. _{.107} = 0.01 A	2.2	6	0.1105	+0.0003
6	0.1102	0.2	0.2	125	75	N.D. _{.107} = 0.02 A	2.25	6	0.1099	-0.0003

MOLYBDENUM.

Under the various metals conditions have been given by which molybdenum may be easily separated from them. The fact, however, that the latter metal can be readily deposited in mercury (p. 164) has made it possible to separate it from vanadium, and yield results which are perfectly satisfactory. The salts employed were sodium molybdate and sodium vanadate. As indicated in experiments Nos. 3 and 4 in the table, it was found best to neutralize, with potassium hydroxide, a portion of the sulphuric acid present after all the

molybdenum but the last traces had been deposited. Large amounts of the acid seem to exert a retarding influence on the final traces of molybdenum. On the other hand the neutralization must not be carried too far, as an oxide of vanadium appears at the anode, when insufficient acid is present. When the molybdenum is completely deposited the solution will be green in color. This may serve as an indication for the interruption of the current.

FROM VANADIUM.

	MOLYBDENUM PRESENT IN GRAMS.	MOLYBDENUM FOUND IN GRAMS.	VANADIUM PRESENT IN GRAMS.	NO. OF CELL USED.	SULPHURIC ACID (SPG. 1.832) PRESENT IN DROPS.	TIME. HOURS.	CONDITIONS.				
							AMPERES.	VOLTS.	AMPERES.	VOLTS.	
1	0.0950	0.0950	0.1002	2	20	20	1.6	6.5	1.5	5.5	(3 hrs.)
2	0.0950	0.0940	0.1002	3	20	18	2	5	1	5	(3 hrs.)
3	0.1900	0.1895	0.0100	2	30	18	1.6	4.5	1.5 ¹	6	(3 hrs.)
4	0.1900	0.1887	0.0100	2	30	20	1.4	4.5	1.2 ²	5.5	(3 hrs.)

¹ Neutralized with caustic potash to 15 drops of sulphuric acid and then run under final conditions for time given.

² Neutralized with caustic potash to 20 drops of sulphuric acid and then run under final conditions for time given.

CHROMIUM.

Since it is possible to precipitate this metal in mercury (p. 148) it is natural to pursue this plan in effecting separations from other metals, especially where these separations are an improvement on earlier proceedings. Thus, when in the form of sulphates, it is comparatively easy to separate chromium from aluminium by using the mercury cathode and stationary anode as described on p. 63. The conditions are sufficiently given in the subjoined examples.

1. From Aluminium.

	CHROMIUM PRESENT IN GRAMS.	CHROMIUM FOUND IN GRAMS.	ALUMINA PRESENT IN GRAMS.	ALUMINA FOUND IN GRAMS.	No. OF CELL.	SULPHURIC ACID, (SP. G. 1.832) PRESENT IN DROPS.	TIME. HOURS.	CONDITIONS.			
								AMPERES.	VOLTS.	AMPERES.	VOLTS.
1	0.1080	0.1080	0.1421	0.1423	1	6	14	0.35	6	0.8	6.5
2	0.1080	0.1081	0.1421	0.1426	2	4	14	0.3	6	0.8	6.5
3	0.0108	0.0107	0.2842		1	6	2	0.3	5.5	0.7	7
4	0.0108	0.0107	0.2842		3	5	1½	0.3	5.5	0.85	7.5
5	0.2160	0.2162	0.0142		1	6	24	0.6	6	1.8	7.5
6	0.2160	0.2158	0.0142		1	5	14	0.4	8	1	7.5

2. From Beryllium.

A wide range in the time necessary for this separation is permissible without injury to the deposit. No deleterious effects are produced by the prolonged action of the current. The requisite conditions are sufficiently given in the following table:

	CHROMIUM PRESENT IN GRAMS.	CHROMIUM FOUND IN GRAMS.	BERYLLIUM OXIDE PRESENT.	No. OF CELL USED.	SULPHURIC ACID (SP. G. 1.832) PRESENT IN DROPS.	TIME. HOURS.	CONDITIONS.			
							AMPERES.	VOLTS.	AMPERES.	VOLTS.
1	0.1080	0.1079	0.0818	1	4	14	0.3	6	3.5	5
2	0.1080	0.1078	0.0818	1	4	4.5	0.3	6	3.5	5

3. ADDITIONAL REMARKS ON METAL SEPARATIONS.

In the preceding pages the greater number of recorded separations have been made with stationary electrodes, although it will be observed that there are numerous records of such as have been conducted with the help of the rotating

anode. This number will be greatly augmented in the course of time, as opportunity for further study in this direction is had. That this field of investigation is attractive and that suggestions of all kinds are sure to be made is most certain. While the writer has not had time to personally investigate all suggestions which have already been made along the line cited he feels constrained to insert at this point the main features of a scheme for metal separation proposed by H. J. S. Sand. In doing this he would emphasize the fact that all separations referred to by Sand have been already carried out after the plan developed in this laboratory for the rapid precipitation of single metals, and are given full expression in the preceding pages. The basal thought of Sand is the "separation of metals by *graded potential*."

A description of the apparatus is as follows:

"Figs. 1a, 1b, 1c illustrate the apparatus (Fig. 36) designed to meet these requirements. It consists of a pair of platinum gauze electrodes, an inner rotating electrode, 1c, and an outer electrode, 1a, which surrounds it on all sides except the bottom. The two are kept in position relatively to each other by means of the glass tube, 1b, which is slipped through the collar A and the ring B of the outer electrode. It is gripped firmly by the former, but passes loosely through the latter. The hollow

FIG. 36.

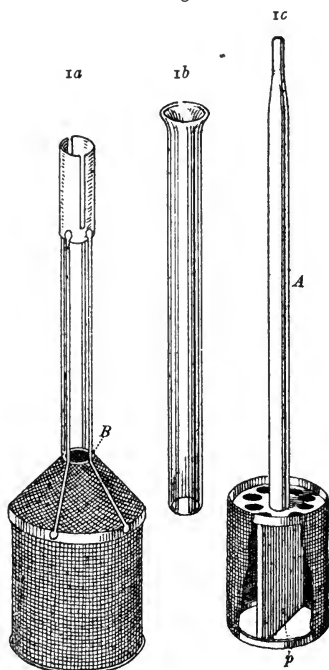

platinum-iridium stem *A* of the inner electrode is passed through the glass tube, in which it rotates freely. The inner electrode is designed to produce a maximum amount of rotation of the liquid, and for this purpose has a vertical partition, *P*. It is open at the bottom and as open at the top as the requirement of rigidity in the construction of the frame will allow. The mesh of the gauze is 14^2 per sq. cm. The gauze of the outer electrode almost completely stops the rotation of the liquid. While the electrolyte is therefore ejected rapidly from the center of the inner electrode by centrifugal force, it is continually replaced by liquid drawn in from the top and the bottom. So great is the suction thus produced that when the electrode is moving rapidly, chips of wood or paper placed on the surface are drawn down to the top of the outer electrode. The circulation is practically independent of the size of the beaker employed. As the outer electrode surrounds the inner completely, the lines of flow of the current are contained between the two, and even when strong currents are employed the potential of the electrolyte anywhere outside the outer electrode is practically the same as that of the layer of liquid in immediate contact with it. This is a matter of great importance when an auxiliary electrode is employed, as it enables the potential difference between the electrode and the electrolyte to be measured at any point in the liquid outside the outer electrode. The space between the surfaces of the two electrodes is about 3 mm. The weight of the outer electrode is about 40 grams, that of the inner electrode about 28 grams. Fig. 37 shows the stand. It will be seen that the beaker containing the electrolyte is always placed on a tripod support.

The outer electrode is gripped by a V-clamp, the cork from the flat side of which has been removed and replaced by platinum foil so as to obtain metallic contact. The inner electrode is held by a small chuck which is flexibly attached to the pul-

ley from which the motion is derived. The figure will fully explain this, as well as the mode of electrical connection by means of the mercury contained in the glass and rubber tubes *C* and *F*. There is thus practically no resistance in the rotating contact, and no chance of its being affected by the air of a chemical laboratory, a matter especially important when the

FIG. 37.

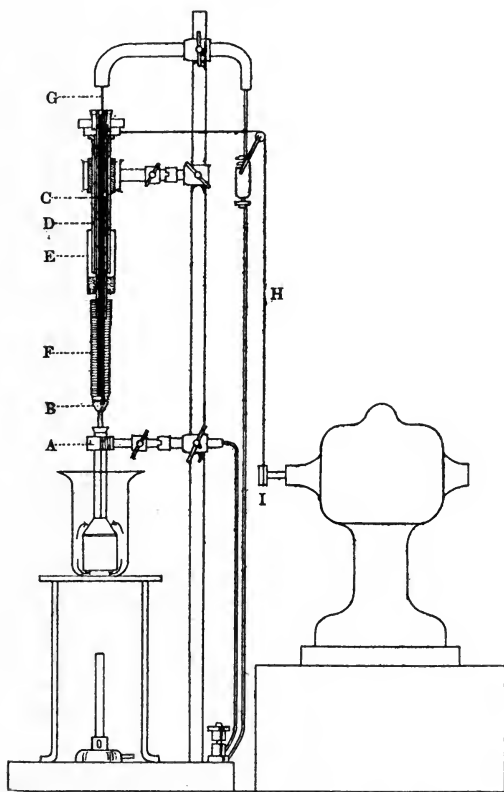

A, Clamp to grip outer electrode; *B*, chuck to grip inner electrode; *C*, glass tube rotating in glass tube *D*; *E*, oil trap on *C*; *F*, thick rubber tube; *G*, amalgamated copper wire dipping into mercury contained in *C* and *F*; *H*, cord made of violin string; *I*, pulley made of rubber tube.

potential difference of the two electrodes is measured for the purpose of separations. All movable connections are made on the base of the stand on two sets of double terminals which are permanently joined to the holders of the electrodes by

FIG. 38.

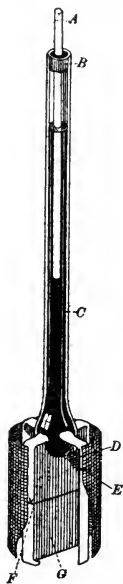

FIG. 39.



FIG. 38.—INNER ELECTRODE WITH GLASS FRAME. *A*, Copper wire held in position in glass stem by slightly narrowed glass tube; *B*, *C*, mercury; *D*, piece of gauze fused through the glass, and, *E*, wire forming connection between *C* and outer gauze; *G*, partition cut from microscope slide held in position by wire *F*.

FIG. 39.—INNER ELECTRODE, No. 2. Stem and mercury as in Fig. 38. *A*, Bulb to spread out gas bubbles; *B*, gauze fused into glass to make connections; *C*, wire forming metal surface of electrode; *D*, *D*, vanes for stirring.

heavy flexible wire. Those parts of the stand which are exposed to the vapors from the electrolyte are painted with several coatings of celluloid in amyl acetate. In order to reduce the amount of platinum required for the apparatus, attempts were made to construct the frame of the inner

electrode of glass and at the same time to retain its essential features. Fig. 38 shows the result of these attempts. The electrode there depicted was in continual use for a month, after which the stem broke. The weight of platinum was less than 5 grams.

To avoid the use of platinum, it might be possible to make the outer electrode of silver when it is used as the cathode. It is probable that the metals deposited on it might be removed after electrolysis by the method of graded potential, although experiments in this direction have not yet been made.

The electrodes *c* Fig. 38 and Fig. 39 are not suitable for solutions containing metals which very readily pass from one stage of oxidation to another, such as copper in ammoniacal liquids, iron, tin, etc. In this case, an anode with a smaller oxidation and stirring efficiency is necessary. The former is obtained by making the surface of the electrode much smaller. Fig. 39 shows the electrode which was designed for this purpose. It is made almost entirely of glass, the total weight of platinum being $1\frac{1}{2}$ grams.

The Auxiliary Electrode.—The auxiliary electrode always used for the present investigation was a mercury-mercurous sulphate-2N sulphuric acid electrode. As an auxiliary electrode has hitherto not been employed in analysis, a special form (Fig. 40) suitable for this purpose was designed. The distinctive feature of this electrode lies in the funnel *F* and connecting glass tube *A B*. It will be seen that the two-way tap *T* will allow the funnel *F* to be connected with either half of the glass tube *A B*, or will close all parts from each other. The half *A* permanently contains the 2N-sulphuric acid solution of the electrode. The half *B*, on the other hand, is filled for each experiment from the funnel *F* with a suitable connecting liquid, generally sodium sulphate solution. The end of *B* is made of thin tube of about 1.5 mm. bore, and is

bent round several times to minimize convection, as will be seen from the figure. While the electrode is in use, the tap, which must be kept free from grease, is kept closed, the film of liquid held round the barrel by capillary attraction making the electrical connection, but towards the end of a determination a few drops are run out in order to expel any salt which

FIG. 40.

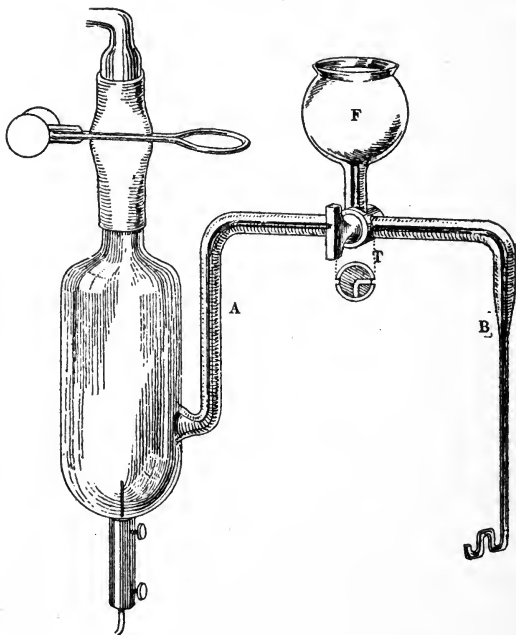

may have diffused into the tube. The normal electrode is held in a separate stand so that it can easily be brought to or removed from the solution undergoing electrolysis.

Electrical Connections.—For separations by graded potential the electrical connection must be made as shown in Fig. 41. The battery is connected directly to the two ends

of a sliding rheostat, the electrolytic cell to one of them and the slider. It is manifestly essential that the sliding contact should be very good. A rheostat by Ruhstrat of Göttingen, with a carrying capacity of 15 amperes and a resistance of 2.6 ohms, proved very satisfactory. It was protected from the atmosphere of the laboratory by a coating of vaseline.

The arrangement (Fig. 42) adopted for the measurement of the potential difference auxiliary electrode-cathode is the one most usually employed at the present time in electrochemical research. The electromotive force to be measured

FIG. 41.

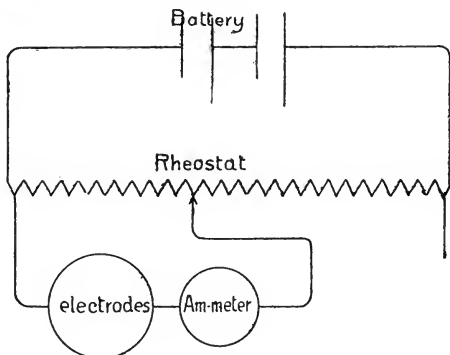

is balanced against a known electromotive force by means of a capillary electrometer. The known electromotive force is drawn from a sliding rheostat, the ends of which are connected with one or two dry cells. The value of the *E.M.F.* is read directly on a delicate voltmeter (range, 1.5 volts). For potential difference greater than 1.5 volts a Helmholtz 1 volt cell was interposed between the auxiliary electrode and the rheostat. The arrangement allows the voltage to be measured almost instantaneously, a matter of great importance in the present case. Owing to the very great advances made in recent years in the construction of

quadrant electrometers and their adjuncts, it seems probable that an electrometer might be permanently fitted up in such a manner as to be used as a direct-reading electrostatic voltmeter (range required, 1 volt; sensitiveness, 1 centivolt). If this were the case it would become as simple a matter to read the potential difference between the cathode and the electrolyte as that between the cathode and the anode.

Consult: Sand, *Trans. Faraday Soc.*, 5, 159; Fischer, *Ch. Z.* 33, 337.

FIG. 42.

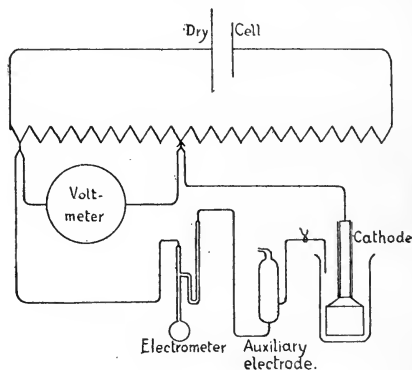

Method of Carrying out an Experiment.—Where not especially stated to the contrary, the metal was always deposited on the outer electrode. To carry out an experiment the cathode, anode, and auxiliary electrode are placed in position, the electrolyte is heated to the required temperature and covered with a set of watch glasses having suitable openings for the electrodes. For the purpose of a separation the current is usually started at about 3-4 amperes and the potential of the auxiliary electrode noted. As a rule this is only slightly above the equilibrium potential. The current is then regulated so that the potential of the electrode may remain constant. When no by-reactions take place the

current falls to a small residual value (generally about 0.2 ampere), as the metal to be separated disappears from the solution. The auxiliary electrode is then allowed to rise 0.1 to 0.2 volt, according to the metal.

It is obviously a matter of great importance to know when all the metal has been deposited. Under the conditions just assumed the amount deposited per unit of time may be taken as roughly proportional to the amount still in solution. This being so, it follows that the amount in solution will decrease in geometrical ratio during successive equal intervals of time. If we, therefore, make the safe assumption that the concentration of the metal has fallen to under 1 per cent. of its original value in the time during which the potential and the current have been brought to their final value, it is clear that by continuing the experiment half as long again, the concentration of the metal will fall to under 0.1 per cent., so that the deposition can then be considered finished.

In cases where by-reactions occur, the current does not fall to zero, but it generally attains a constant value which allows one to see when all the metal has been removed. In certain cases the absence of the latter can be roughly tested for chemically, and by continuing the experiment for about half as long again as this reaction demands, the metal may be safely assumed to have been deposited completely. This method may be adopted, for example, in the separation of lead from cadmium, the former being roughly tested for by sulphuric acid. If none of these methods is available, the metal must be deposited to constant weight or else the separation must be carried out under very carefully defined conditions for a length of time proved more than sufficient by previous experiment.

Interrupting an Experiment.—A short time before completing the analysis, the inside of the tube, the sides of the

beaker, and the watch glasses are washed by the aid of a wash-bottle and a few drops of liquid run out of the connecting limb of the auxiliary electrode. To interrupt the experiment, the auxiliary electrode and the clock glasses are removed, the tripod is then taken from under the beaker and the latter lowered until the surface of the liquid is just below the outer electrode. During this time the latter is washed. The stirrer is now stopped before lowering the beaker any further. The latter is then replaced by a slightly larger one, the tripod put back and the electrode again washed. It is then disconnected, shaken, dipped first into a jar containing alcohol, shaken, then into another containing ether, and then dried for about a minute over a Bunsen burner. The collar is carefully dried by a silk cloth before weighing. The remaining liquid is washed into the larger beaker and is then ready for the deposition of the next metal.

When only one metal is contained in the solution undergoing analysis, it is simpler to stop the stirrer, take away the beaker, and replace it by two successive ones containing distilled water. In both cases the current is left on during the process of interruption.

The beaker in which the first deposition of a separation is carried out was only slightly wider than the electrode and the amount of the liquid roughly 85 c.c. In the second separation the amount was usually 130 c.c. and so on.

The rate of stirring varied very considerably from one experiment to another without greatly affecting the result. It may be taken as having been between the limits of 300 and 600 revolutions per minute. Consult Sand, *J. Ch. S.* (London), **91**, 374; *ibid.* (1908), **93**, 1572; *Trans. Faraday Soc.* (1909), **5**, 159; *ibid.* (1911), **6**, 205.

Consult also A. Fischer, *Z. f. Elektrochem.*, **13**, 469; *Z. f. angew. Ch.*, **20**, 134 (1907).

4. DETERMINATION OF THE HALOGENS IN THE ELECTROLYTIC WAY.

LITERATURE.—Whitfield, *Am. Ch. Jr.*, **8**, 421; Vortmann, *Elektroch. Z.*, **1**, 137; **2**, 169; E. Müller, *Ber.* (1902), **35**, 950; Specketer, *Z. f. Elektrochem.*, **4**, 539; Withrow, *J. Am. Ch. S.*, **28**, 1356.

Whitfield proceeds as follows: The silver halide is collected in a Gooch crucible and dried directly over a low Bunsen flame. After weighing it is dissolved by introducing the crucible and asbestos into a concentrated potassium cyanide solution. The silver is then deposited in a platinum dish of 100 cm.² surface with a current of 0.07 ampere. It is not advisable to work with more than 2 grams of silver halide.

Vortmann has developed an electrolytic scheme for the direct determination of the halogens. As he has given the most attention to iodine, its method of estimation will be presented here.

To the aqueous solution of potassium iodide were added several grams of Seignette salt and 16–20 c.c. of a 10 per cent. solution of sodium hydroxide. The liquid was then diluted to 150 c.c. and placed in a crystallizing dish or in a platinum dish. If the first was used, then a platinum disk, 5 cm. in diameter, was made the cathode, whereas in the second instance the dish itself became the cathode, the anode being a circular plate of pure silver, 5 cm. in diameter, or a plate of platinum of like size, coated with silver. The electrolysis was made with a current of 0.03–0.07 ampere and 2 volts. It was found expedient, after several hours, to replace the anode coated with silver iodide with another, and the electrolysis was continued until the anode ceased to increase in weight. This change in anodes is absolutely necessary when the quantity of iodine exceeds 0.2 gram. The

iodine may exist as iodide or iodate. The alkaline tartrate is introduced to prevent the silver iodide from becoming detached.

a. Determination of Iodine in the Presence of Bromine and Chlorine.

The method is based on the fact that an iodide in the presence of a soluble chromate in alkaline solution is oxidized to iodate at a pressure insufficient for the conversion of bromides and chlorides into their corresponding oxysalts. The iodate produced is estimated by titration with thiosulphate, and the quantity of thiosulphate used by the known amount of chromate present, is then deducted. Chromate, even in small amounts, prevents reduction at the cathode. Further, periodate is not produced. It is necessary always to platinize anew the platinum cathode. A pressure of 1.6 volts does not form bromate in a 0.1 to 0.01 normal solution, while all of the iodine is changed to iodate. The following solutions were used in the analysis:

1. A potassium chromate solution, of which 1 cubic centimeter = 10.6 c.c. 1/100 N thiosulphate solution.
2. Normal caustic potash.
3. Solution of potassium iodide, of which 1 cubic centimeter = 9.13 cubic centimeters 1/100 N silver nitrate solution.

In determining iodine in the absence of the other halogens mix: 2 cubic centimeters of solution 1; 1 cubic centimeter of solution 2; 10 cubic centimeters of solution 3 and 90 cubic centimeters of water. Electrolyze for a period of twenty hours with a pressure of from 1.6 to 1.61 volts. Titration with sodium hyposulphite solution gave 0.11594 gram and 0.11632 gram of iodine instead of 0.1158 gram.

In the presence of chlorine, use:

2 cubic centimeters of solution 1

1 cubic centimeter of solution 2

1 cubic centimeter of solution 3 and

100 cubic centimeters of a saturated sodium chloride solution.

Time, 20 hours. Volts 1.59 to 1.60.

Result: 0.01163 and 0.01167 instead of 0.1158.

In the presence of bromine, use:

2 cubic centimeters of solution 1

1 cubic centimeter of solution 2

1 cubic centimeter of solution 3 and

100 cubic centimeters of a normal potassium bromide solution.

Time, 22 hours. Pressure, 1.6 to 1.61 volts.

Results: 0.01158 and 0.01170 instead of 0.01158.

Test the reagents beforehand with potassium iodide and sulphuric acid to ascertain whether they liberate iodine. This often occurs with the alkali solutions of trade. The anode must be wholly immersed in the solution, because if iodine is separated directly at the surface, it readily vaporizes. The point of contact of the conducting wire with the solution should be covered with glass. Alkaline earths should be absent.

b. Separation of the Halogens.

Metals have been separated by graded potential (Kiliani, Freudenberg, etc.). This principle has been applied recently to the halogens. In the hands of Specketer good results have been obtained. The electrolysis is carried out in sulphuric acid solution of normal concentration. The method of conducting the experiment is briefly as follows: Use a Gülcher thermopile. It possesses superior advantages for this particular kind of work, as constancy of current is an absolute necessity. The pressure of the form used by Specketer was three volts. The vessel in which the electrolysis is performed should be narrow and tall, something like a measuring cylinder, so that nothing is lost by spattering, occasioned by conducting hydrogen through the electrolyte

during the analysis, and in order that the washing of the anode may be directly done in the cylinder, the latter should be closed with a cork, carrying the cathode of sheet platinum and an anode of silver gauze, and sufficiently large to permit of the passage of a gas delivery tube through it. The hydrogen finds its exit immediately back of the cathode plate. A voltmeter should be in circuit. The conclusion of the analysis is indicated by a delicate Edelmann galvanometer so arranged that it can readily be thrown in or out of the circuit. The salts used were pure potassium chloride, bromide, and iodide.

1. Separation of Iodine from Chlorine.

PRESSURE = 0.13 volt.

<i>a.</i> IODINE USED.	<i>b.</i> IODINE FOUND.
0.2987 gram	0.2992 gram
0.2394 gram	0.2386 gram
0.0481 gram	0.0480 gram
0.1543 gram	0.1532 gram

When the iodine was completely precipitated, the current was interrupted, the anode washed off in the cylinder and then dried at 120°. The chlorine was determined in the residual liquid by the Volhard method.

2. Separation of Bromine from Chlorine.

PRESSURE = 0.35 volt.

<i>a.</i> BROMINE PRESENT.	<i>b.</i> BROMINE FOUND.
0.1943 gram	0.1940 gram
0.2735 gram	0.2736 gram
0.1962 gram	0.1958 gram
0.1899 gram	0.1906 gram

The chlorine was again determined volumetrically.

3. Separation of Iodine from Bromine.

PRESSURE = 0.13 volt.

<i>a.</i> IODINE PRESENT.	<i>b.</i> IODINE FOUND.
0.1706 gram	0.1685 gram
0.1636 gram	0.1610 gram
0.2029 gram	0.2036 gram

It should be constantly borne in mind that to make these separations successfully air must be absolutely excluded, the source of current must be constant and a definite acid concentration must be maintained.

5. DETERMINATION OF NITRIC ACID IN THE ELECTROLYTIC WAY.

LITERATURE.—V o r t m a n n, Ber., **23**, 2798; E a s t o n, J. Am. Chem. S., **25**, 1042; I n g h a m, J. Am. Ch. S., **26**, 1251. B ö t t g e r, Z. f. Elektroch., **16**, 698; P a t t e n, Trans. Am. Electroch. S., 1908; S h i n n, J. Am. Ch. S., **30**, 1378.

To the solution of the nitrate, in a platinum dish, add a sufficient quantity of copper sulphate. Acidulate the liquid with dilute sulphuric acid and electrolyze with a current of 0.1 to 0.2 ampere. When the deposition of the copper is completed, pour off the liquid, reduce it to a small volume, and distil off the ammonia in the usual manner. The quantity of copper sulphate added should be determined by the quantity of nitric acid present. If potassium nitrate is the salt undergoing analysis, add half of its weight in copper sulphate.

Easton gave the following as satisfactory conditions, when using stationary electrodes: an equal weight of copper nitrate and copper sulphate, 30 c.c. of sulphuric acid of specific gravity 1.062, a dilution of 150 c.c., a platinum anode, a cathode of lead or copper, or a platinum dish of 200 c.c. capacity, 0.15 to 3 amperes, 3 to 8 volts, and one and a quarter to eight and one-half hours.

The Rapid Determination of Nitric Acid With the Use of a Rotating Anode.

This method has been most carefully elaborated by Leslie H. Ingham in this laboratory. The results of his experiments are given here.

Employ in this determination the apparatus described on p. 78 in estimating copper.

Use the following solutions:

1. A fifth-normal solution of sodium carbonate. This solution constitutes the basis of value of the subsequent solutions.
2. A dilute solution of sulphuric acid, containing about 20 cubic centimeters of acid of specific gravity 1.84 in 4 liters of water. Standardize this on the sodium carbonate solution.
3. A dilute ammonia solution, containing about 50 cubic centimeters of ammonium hydroxide of specific gravity 0.95 in 4 liters of water. This is about equivalent in strength to the standard acid solution. Obtain its exact ratio by titration.
4. A solution of copper sulphate, containing about 80 grams of $\text{CuSO}_4 \cdot 5\text{H}_2\text{O}$ in 2 liters.

Experimental Part.

Weigh off the desired quantity of potassium nitrate and dissolve it in a small amount of water in a clean platinum dish; then pipette from the stock solution the necessary amount of copper sulphate and add a measured amount of standard acid, sufficient to make the electrical resistance low and to insure the solution remaining quite strongly acid during the reduction of the nitrate.

Dilute to about 125 cubic centimeters and electrolyze with about 4 to 5 amperes and about 10 volts. During the course of the electrolysis the copper is deposited on the cathode and its equivalent of sulphuric acid is liberated and added to the acid already present, whereby the conductivity is increased and the pressure falls. As the nitric acid is gradually reduced to ammonia the free acid becomes neutralized and if the current be maintained constant by the rheostat the pressure will gradually rise for about twenty-eight minutes and then become stationary, thereby indicating the end of the reduction.

At the end of the reduction stop the motor, siphon off the liquid in the dish into a beaker and replace it by distilled water while the current passes; the dish, anode and cover glasses are well washed, the electrical current interrupted, and the washings added to the liquid in the beaker. It is unnecessary to weigh the deposited copper, so the platinum dish is merely rinsed with nitric acid and washed under the faucet, when it is ready for use again.

Rapidly neutralize the contents of the beaker, in the presence of litmus or methyl orange by the standard ammonia solution from a burette. The indicators named were found to give identical results. Note that in the reaction of reduction one molecule of potassium nitrate gives rise to a molecule of potassium hydroxide and one of ammonia; hence two equivalents of alkali are produced from one equivalent of nitrate, and allowance must be made for this by having the results obtained by titration. The use of a 0.5-gram sample for analysis just offsets this. The calculation of the standard ammonia solution to its equivalent of N/5 sodium carbonate solution and thence to nitrogen is obvious.

This method for the determination of nitrates compares quite favorably with other methods in point of accuracy. Its advantages in simplicity and speed are worthy of careful consideration, as a complete determination of the nitric acid content of an alkali nitrate may be made in thirty-five minutes from the time of weighing off the sample.

At intervals reports have appeared that the scheme as outlined by Ingham failed to yield results such as are given by him. It has been declared that intermediate reduction products were found, such as the lower oxides of nitrogen or hydroxylamine. In this laboratory Shinn has carefully reviewed the entire work and has made search for possible disturbing factors without success. He reached the conclusion, however, that the rapidity of the deposition of the

copper is largely dependent on the rotating speed of the anode, and that it is advisable to have copper sulphate in solution until the reduction of the acid is completed. He accordingly added 25 c.c. of copper sulphate solution (=0.25 gram of copper) at intervals during the electrolysis and obtained 13.87, 13.81, 13.82, 13.90 per cent. of nitrogen instead of 13.83 per cent. He demonstrated the possibility of duplicating Ingham's results by merely prolonging the precipitation of the copper by reducing the speed of rotation of the anode. He found that a pressure of 10 volts with a current of 4 to 5 amperes was quite sufficient for the purpose; further, the many trials conducted by students have only confirmed the previous work upon this interesting determination.

Experiments, made in this laboratory, have demonstrated that to determine the nitric acid content of such salts as zinc nitrate, cobalt nitrate, nickel nitrate, etc., it is advisable to precipitate the metal with sodium carbonate, filter out the precipitate and electrolyze the filtrate containing the sodium nitrate.

6. SPECIAL APPLICATION OF THE ROTATING ANODE AND MERCURY CATHODE IN ANALYSIS.

LITERATURE.—Hildebrand, *J. Am. Ch. S.*, **29**, 447; McCutcheon, *J. Am. Ch. S.*, **29**, 1445; Lukens and Smith, *J. Am. Ch. S.*, **29**, 1455; McCutcheon and Smith, *J. Am. Ch. S.*, **29**, 1400; Kollock and Smith, *Proc. Am. Philos. Soc.*, **46**, 34; Goldbaum and Smith, *J. Am. Ch. S.*, **30**, 1705, **31**, 900, **32**, 1468; Goldbaum, *J. Am. Ch. S.*, **33**, 35.

Determination of both Cations and Anions.

In the preceding pages numerous examples have been given of the determination of metals with the help of the simple device pictured (Fig. 22) on p. 63. Under copper, for instance, it is suggested that the student perform the

analysis of copper sulphate, depositing the metal in the mercury, then siphoning off the colorless solution into a beaker and determining the acid by titration with a N/10 solution of sodium carbonate. To this it may be added that no more satisfactory method can be adopted in the analysis of zinc sulphate. Both constituents can be rapidly and accurately estimated. In the ordinary gravimetric determination of the sulphuric acid content of white vitriol the precipitate of barium sulphate is very apt to contain zinc, so by this electrolytic procedure the analyst gains great advantage. The simplicity of the procedure appeals strongly to those who are called upon to perform analyses of salts like those just mentioned. Indeed, any soluble metallic sulphate may be analyzed in this manner. The results have been most satisfactory. When the method was first applied to them, the anode was stationary (J. Am. Chem. S., 25, 883); subsequently it was rotated (J. Am. Chem. Soc., 26, 1614; Am. Phil. Soc., Pr. XLIV, 137 (1905); J. Am. Chem. S., 27, 1527; Myers, J. Am. Ch. S., 26, 1124).

Having reached a high degree of success in the analysis of sulphates in the direction outlined in the preceding paragraphs, it occurred to the writer that possibly chlorides might be analyzed equally well in this way if provision were made to catch or fix the chlorine ions. Accordingly, a solution of sodium chloride was subjected to decomposition in the little cup (Fig. 22, p. 63). The anode consisted of a silver-plated strip of platinum, which later was replaced by a weighed, silver-coated platinum gauze suspended in the aqueous solution (40 c.c.) of the sodium chloride. Almost immediately the silver, on passage of the current, began to darken in color from the lower edge of the gauze upwards. When this ceased, the decomposition was assumed to be at an end, whereupon the gauze was raised from the solution, rinsed with water and further washed with alcohol and ether. It was weighed after

drying for a short time. For the gauze a platinum spiral was substituted in the residual liquor in the beaker; the current was reversed, the layer of mercury being made the anode, whereupon the sodium was rapidly driven into the water. All this occupied about twenty minutes, after which the alkaline liquor was titrated with standardized acid.

A solution of salt containing 0.0606 gram of chlorine and 0.0390 gram of sodium gave:

No.	C GRAM.	Na GRAM.
1.....	0.0606	0.0389
2.....	0.0610	0.0384

Six hours were allowed for the decomposition. The current showed 0.0325 to 0.03 ampere and 2 volts.

On electrolyzing a solution of barium chloride, in the same way, there were obtained:

Ba PER CENT.	Cl PER CENT.		Ba PER CENT.	Cl PER CENT.
55.87	28.69	instead of	56.14	29.09
56.07	29.31			

Strontium bromide was analyzed with just as much success. The same is true of other halides. Indeed, both sodium chloride and barium chloride were electrolyzed successfully with the use of the mercury cathode. A flat, platinum spiral was made to take its place. The alkaline liquors, observing proper current conditions, did not interfere with the deposition of the halogen upon the silver gauze.

In the preceding example the time factor was somewhat prolonged and difficulty was experienced in determining the end of the reaction. Hildebrand, working in this laboratory, found that in spite of the extreme care in keeping the mercury and the interior of the cell absolutely clean so as to minimize secondary decomposition of the amalgam some caustic was formed, and after the halide had been completely decomposed it was possible to increase the weight of the

gauze indefinitely by the production of silver oxide from the electrolysis of the caustic. To learn the end of the decomposition the following scheme was pursued: the gauze was suspended, at the beginning of the operation, within about 5 mm. of the surface of the mercury and the liquid so diluted as to cover only about one-third of the gauze. The pressure (voltage) was kept constant during the electrolysis so that the fall in current strength, as the action progressed, indicated the completeness of the decomposition. When it reached from 0.005 to 0.02 amperes, the liquid level was raised a few millimeters from time to time, and as soon as the fresh surface showed the formation of brown silver oxide—which could easily be distinguished from the bluish chloride—the gauze was removed, immersed in alcohol, then in ether, dried and weighed. This procedure gave consecutive concordant results. In every case the amalgam was washed into a beaker and, after it had decomposed, the alkali was titrated with tenth normal sulphuric acid, using methyl orange as an indicator.

Analysis of Sodium Chloride.

The following table shows the results obtained for this salt. The current in amperes, at the beginning and end of each decomposition, is given in the third column.

TIME. MINUTES.	VOLTS.	AMPERES.	SODIUM IN GRAMS.		CHLORINE IN GRAMS.	
			PRESENT.	FOUND.	PRESENT.	FOUND.
135	3.5	0.08-.01	0.0460	0.0461	0.0708	0.0713
210	3.5	0.09-.003	0.0460	0.0456	0.0708	0.0706
150	3.5	0.20-.005	0.0460	0.0460	0.0708	0.0706
220	3.5	0.24-.005	0.0460	0.0458	0.0708	0.0705
200	3.5	0.21-.005	0.0460	0.0462	0.0708	0.0709
120	3.5	0.16-.01	0.0460	0.0459	0.0708	0.0712
130	3.5	0.20-.02	0.0460	0.0461	0.0708	0.0705
70	3.5	0.15-.04	0.0460	0.0459	0.0708	0.0707
	3.5	0.14-.03	0.0460	0.0463	0.0708	0.0711
	3.5	0.13-.02	0.0460	0.0463	0.0708	0.0710

The deposits were perfectly adherent in character unless the silver coating was too thin. No attempt was made to protect it from the light, so that the deposits both here and with other substances were always very dark colored; in fact, with several other salts if the silver salt was formed so rapidly as to show its true color at places, it was often not very adherent.

Analysis of Sodium Bromide.

TIME. MINUTES.	VOLTS.	AMPERES.	SODIUM IN GRAMS.		BROMINE IN GRAMS.	
			PRESENT.	FOUND.	PRESENT.	FOUND.
60	4.0-3.5	0.13-.02	0.0232	0.0235	0.0804	0.0794
45	4.0-3.5	0.15-.05	0.0232	0.0237	0.0804	0.0806
50	3.5	0.12-.03	0.0232	0.0231	0.0804	0.0806
100	3.5	0.13-.01	0.0232	0.0237	0.0804	0.0812
60	3.5	0.12-.05	0.0232	0.0238	0.0804	0.0804
	3.5	0.09	0.0232	0.0230	0.0804	0.0805

Analysis of Sodium Iodide.

TIME. MINUTES.	VOLTS.	AMPERES.	SODIUM IN GRAMS.		IODINE IN GRAMS.	
			PRESENT.	FOUND.	PRESENT.	FOUND.
70	4-3.5	0.10-.02	0.0154	0.0156	0.0850	0.0850
70	3.5	0.05-.01	0.0154	0.0156	0.0850	0.0857
45	3.5-3	0.10-.02	0.0154	0.0154	0.0850	0.0845

Analysis of Potassium Sulphocyanide.

This salt proved more troublesome because the potassium amalgam usually started to decompose rapidly near the end of the electrolysis.

It was soon after found that silver ferro- and ferricyanides could be formed and, what seemed still more remarkable, silver carbonate. In the last instance the decomposition was complete, there being no traces of carbon dioxide liberated

at the anode. The deposit, afterwards immersed in dilute sulphuric acid, liberated carbon dioxide with effervescence. However, it was impossible to make these depositions quantitative, because the silver salts were not very coherent and at the edge of the gauze near the mercury, where the deposit was thick, part of it always became detached.

TIME. MINUTES.	VOLTS.	AMPERES.	POTASSIUM IN GRAMS.		CNS IN GRAMS.	
			PRESENT.	FOUND.	PRESENT.	FOUND.
45	3.5	0.10-.06	0.0375	0.0371	0.0558	0.0558
120	3.5	0.07-.04	0.0375	0.0379	0.0558	0.0560
105	4-3.5	0.10-.01	0.0375	0.0379	0.0558	0.0560
135	3.5	0.06-.01	0.0375	0.0375	0.0558	0.0566
65	4-3.5	0.09-.01	0.0375	0.0373	0.0558	0.0553

The difficulty here mentioned was overcome by devising a new anode. This consisted of two circular disks of platinum gauze 5 cm. in diameter and having 300 meshes per square centimeter. The circumference was slightly fused in the blowpipe. These were mounted 5 mm. apart on a stout platinum wire 1 mm. in diameter and 10 cm. long which passed through the centers of the disks perpendicular to them. Each disk was attached to this axial wire by means of two smaller wires fitting tightly into two adjacent holes drilled at right angles to each other through the large wire. These anodes weighed about 16 grams apiece. The total surface of each pair of disks is about 100 sq. cm., which is at least doubled when coated with several grams of silver. These anodes were always supported when not in use by fastening the axis in a clamp so that the gauze might not come in contact with anything which might bend it. In order to suspend them from the balance beam in weighing, a loop of fine platinum wire was soldered to each axial wire about 2 cm. from the top.

Silver Plating the Anode.—In plating the anodes with silver the rotator was always used, as a coating of from 3 to 4 grams of silver could thus be deposited. A number of determinations could then be made without replating the gauze, the deposited silver chloride being merely dissolved off by immersing for a few moments in potassium cyanide, thus exposing a fresh surface of silver. The plating was done in a beaker, the anode being a platinum wire passing through a glass tube to the bottom of the beaker, where it was bent into a flat horizontal spiral.

The Cell.—In principle it resembles the Castner-Kellner process for caustic soda, the amalgam being formed in one compartment and decomposed in another. The outer cell is a crystallizing dish 11 cm. in diameter and 5 cm. deep. Inside of this is a beaker 6 cm. in diameter with the bottom cut off and the edge rounded so that a ring is formed 4.5 cm. high. This rests on a large Y of thin glass rod on the bottom of the crystallizing dish and is kept in position by three rubber stoppers fitting radially between it and the inside of the dish. In the outer compartment thus formed there is a ring of nickel wire provided with three legs which are fastened to the ends of the glass Y and serve to support the ring about 1 cm. above the surface of the mercury when sufficient of the latter is poured in to seal off the two compartments. The cell and anode are shown in Fig. 43.

In using this cell, which must be kept scrupulously clean, pure clean mercury is poured in so that its level is about 3 mm. above the lower edge of the bottomless beaker. The solution to be electrolyzed is then put into the inner compartment; into the outer is placed enough distilled water to cover the nickel wire, and to this is added a cubic centimeter of a saturated solution of common salt. By this arrangement the amalgam formed in the inner compartment is decomposed in the outer, which acts as a cell whose elements are amalgam-sodium chloride-

nickel wire. The sodium chloride serves merely to make the liquid a conductor so that the action may proceed more rapidly

FIG. 43.

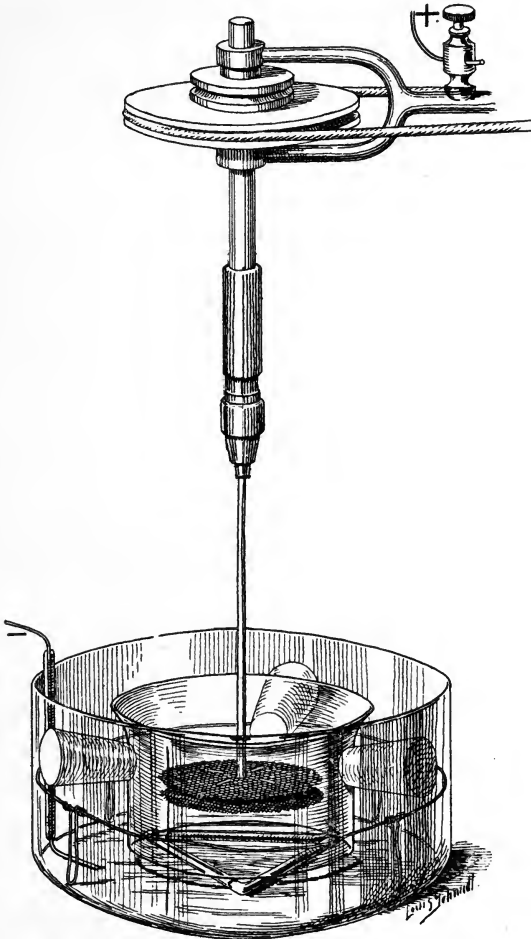

at the beginning. The mercury is connected with the negative pole of the battery by means of the glass tube bearing the

copper and platinum wires described above, which dips into the outer compartment. After the electrolysis is complete the entire contents of the cell are poured into a beaker, the cell rinsed and the alkali titrated. After titration the mercury is washed, the water decanted and the metal poured into a large separatory funnel, from which it can be drawn off clean and dry. How well this new arrangement of anode and new cell worked in the analysis of sodium chloride the following results attest:

TIME. MINUTES.	VOLTS.	AMPERES.	POTASSIUM IN GRAMS.		CHLORINE IN GRAMS.	
			PRESENT.	FOUND.	PRESENT.	FOUND.
30	4.0-2.5	0.50-02	0.0461	0.0459	0.0708	0.0704
45	3.5-2.5	0.34-01	0.0461	—	0.0708	0.0706
40	3.5-3.0	0.50-01	0.0461	—	0.0708	0.0704
45	4.0-3.5	0.65-01	0.0461	—	0.0708	0.0716
30	4.0-2.5	0.76-02	0.0461	—	0.0708	0.0713
55	3.0	0.26-02	0.0461	—	0.0708	0.0709

Thus far the anode has remained stationary. Henceforth, all results given will be those obtained with the help of the rotating anode.

The weighed gauze anode should be clamped to the shaft. Lower the latter in the cell till the lower gauze is about 5 mm. from the surface of the mercury. Adjust the motor and the belt, start the motor and turn on the electrolyzing current. The most convenient speed for the motor would be about 300 revolutions per minute.

Many valuable experiences have been had with this scheme of analysis, but at times it seemed that inherent defects existed in it. Determinations were made in large numbers with every success, and then perhaps would follow a series of discordant results. To determine the cause of these Dr. J. S. Goldbaum of this laboratory undertook a painstaking study of the same. In

most of the silver plating a potassium cyanide bath was used and there was a possibility of the retention of some soluble cyanide in the gauze, even after the plated anode had been washed with water and gently ignited. This difficulty was absolutely eliminated by dipping the freshly plated silver gauze in dilute hydrochloric acid, washing it thoroughly with distilled water, and then heating it to incipient redness in a low Bunsen flame. This treatment destroys any admixed cyanide. Again, a fact long known in this laboratory was the secondary formation of oxide upon the anode along with the halide. To obviate its disturbing effect, the washed anode carrying the halide should be dried in an electric oven registering a temperature of from 300° to 400° C. With the pressure usually employed in the double cup (2.5 to 5 volts) let the anode be placed at least 15 mm. from the level of the mercury.

Goldbaum further observed that unless care is exercised in the plating of the platinum gauze *completely* with silver, low results may follow, because if the anion which is expected to attach itself to the silver comes in contact with platinum, it is oxidized, *e. g.*, chlorine to hypochlorite or chlorate. The plating of the platinum gauze with silver may be made in a bath of the double oxalate of silver and ammonium. The silver from such a bath has a more porous character and presents a greater surface to the action of the ionic halogen during the electrolysis. (Jr. Am. Ch. S., **32**, 1468; *ibid.*, **33**, 35.)

Analysis of Sodium Bromide.

TIME. MINUTES.	VOLTS.	AMPERES.	SODIUM IN GRAMS.		BROMINE IN GRAMS.	
			PRESENT.	FOUND.	PRESENT.	FOUND.
30	5.0	0.65-.01	0.0231	0.0233	0.0800	0.0798
30	5.0	0.65-.01	0.0231	0.0233	0.0800	0.0802

Analysis of Sodium Carbonate.

In this determination it is well to have the silver anode surface slightly roughened. This can be obtained by stopping the rotator several minutes before removing the gauze anode from the silver plating bath.

RESULTS.

TIME. MINUTES.	VOLTS.	AMPERES.	SODIUM IN GRAMS.		CO ₂ IN GRAMS.	
			PRESENT.	FOUND.	PRESENT.	FOUND.
60	3.5-5.0	0.15-.01	0.0323	0.0325	0.0420	0.0416
90	4.0-5.0	0.15-.01	0.0323	0.0324	0.0420	0.0419
50	5.0	0.65-.01	0.0346	0.0349	0.0450	0.0448
70	3.5-5.0	0.15-.01	0.0346	—	0.0450	0.0447

In this instance the easiest way to clean the gauze is to ignite it gently instead of the usual washing with potassium cyanide, water and then drying.

Analysis of Potassium Ferrocyanide.

TIME. MINUTES.	VOLTS.	AMPERES.	POTASSIUM IN GRAMS.		Fe(CN) ₆ IN GRAMS.	
			PRESENT.	FOUND.	PRESENT.	FOUND.
30	4.0-4.5	0.15-.01	0.0391	0.0384	0.0531	0.0531
30	3.0-5.0	0.15-.01	0.0391	0.0389	0.0531	0.0532
30	4.0-5.0	0.20-.01	0.0391	0.0387	0.0531	0.0527

Analysis of Potassium Ferricyanide.

TIME. MINUTES.	VOLTS.	AMPERES.	POTASSIUM IN GRAMS.		Fe(CN) ₆ IN GRAMS.	
			PRESENT.	FOUND.	PRESENT.	FOUND.
35	2-5	0.20-.01	0.0392	—	0.0710	0.0714
30	4-5	0.40-.01	0.0392	0.0389	0.0710	0.0712
40	4.5-5	0.30-.01	0.0392	0.0389	0.0710	0.0713

Analysis of Trisodium Phosphate.

Trisodium phosphate gave a deposit which was satisfactory at 4 volts but not completely adherent at 5 volts. The lower voltage and the smaller conductivity made a longer time necessary to get out the last traces. To avoid this, in the last two determinations a second anode was used near the end to receive these traces.

TIME. MINUTES.	VOLTS.	AMPERES.	SODIUM IN GRAMS.		PO ₄ IN GRAMS.	
			PRESENT.	FOUND.	PRESENT.	FOUND.
75	5-4	0.50	0.0343	0.0343	0.0472	0.0473
120	4	0.30	0.0343	0.0343	0.0472	0.0468
60	4	0.30	0.0343	0.0340	0.0472	0.0470
70	4	0.40	0.0343	—	0.0472	0.0478

See Hildebrand, *J. Am. Ch. S.*, **29**, 447.

Subsequently the chlorine content of hydrochloric acid and the bromine content of hydrobromic acid were determined with the aid of the mercury cup.

The hydrochloric acid was first standardized by the well-known precipitation method with silver nitrate. The residue from 40 c.c. of the solution, containing 0.1418 gram of hydrogen chloride, weighed 0.0001 gram. Only freshly distilled water was used for dilution. In the first two determinations, a "double-cup" was used, but since in the case of hydrochloric acid this presented no advantage over a cell with a single compartment, the latter was employed for the subsequent determinations. This cell consisted of an ordinary beaker, 6 cm. in diameter and 8 cm. high, containing a layer of pure mercury 3 mm. deep. Cathode connection was made with the mercury by means of a platinum wire sealed in a glass tube. The anode was the usual disk gauze type. It made 300 revolutions per minute. The total dilution of the electrolyte was 90 c.c. The liquid remaining

in the beaker after the current was interrupted was found in every case to be neutral to methyl orange, and when tested with silver nitrate and with starch and potassium iodide, hypochlorous acid or hypochlorites were invariably absent. The liquid remaining after electrolysis was perfectly transparent and clear. The mercury used for cathode had been distilled several times and was carefully examined for silver before and after the electrolysis, but none was found. Hence there was no transference of the metal from the anode to the cathode.

	CHLORINE TAKEN IN HCl GRAM.	TIME. MINUTES.	VOLTS.	AMPERES.	CHLORINE FOUND.	ERROR.
1.	0.0709	20	2.5-5.0	0.85-0.01	0.0707	-0.0002
2.	0.0709	22	2.5-5.0	0.80-0.005	0.0710	+0.0001
3.	0.1418	28	2.5-5.0	0.95-0.01	0.1410	-0.0008
4.	0.1418	30	2.5-5.0	0.95-0.015	0.1416	-0.0002

The results obtained with hydrobromic acid confirm those with chlorine and prove beyond question that the method in these instances is reliable and exact. (See also Goldbaum, J. Am. Ch. S., 33, 35.)

Ammonium Chloride.

In the analysis of ammonium chloride let the electrodes be 1 cm. apart. The anode should make 750 revolutions per minute and the initial pressure should be 3 volts, slowly increasing to 8 volts, but as the end of the electrolysis is approached, gradually return the pressure to 3 volts. The cathode surface should equal 20 sq. cm. Add a slight excess of standard hydrochloric acid to the contents of the outer cup so as to prevent the loss of ammonia by volatility. The volume of the liquid in the inner cup should not exceed 50 cubic centimeters:

NH ₄ Cl PRESENT IN GRAMS.	NH ₄ PRES- ENT IN GRAMS.	NH ₄ FOUND IN GRAMS.	Cl PRES- ENT IN GRAMS.	Cl FOUND IN GRAMS.	VOLTS.	AMPERES. N.D. ²⁰ .	TIME. MIN- UTES.
0.1002	0.0338	0.0331	0.0664	0.0658	5	0.28-0.02	32
0.1057	0.0356	0.0350	0.0701	0.0695	3-8-3	0.15-0.01	35

Ammonium bromide and ammonium sulphocyanate were analyzed with just as great accuracy and ease. (Goldbaum and Smith, *J. Am. Ch. S.*, **30**, 1707.)

Cesium chloride, rubidium chloride, and lithium chloride may be analyzed in the same fashion. In short, the method answers excellently for the determination of all the alkali metals.

Separation of the Alkali Metals.

Further, it was discovered that the separation of these metals was possible by observing the differences in the decomposition pressure of their chlorides. For example, place a mixture of sodium chloride and potassium chloride in the inner compartment of the double cup. Rotate the anode and close the circuit. As the point of decomposition of potassium chloride is $4/30$ volt higher than that of sodium chloride, raise the pressure to $2/30$ volt higher than the "break-point" of the mixture and carefully maintain this pressure to the end of the electrolysis. The sodium chloride alone will be decomposed, its chlorine forming silver chloride at the anode, while its sodium will pass into the mercury and form sodium hydroxide with the water in the outer cup. The disappearance of the "break" of sodium chloride and the substitution for it of the higher decomposition pressure of potassium chloride are the evidences of the completion of the electrolysis. This separation is helpful in the determination of small quantities of the alkali metals which occur in silicates.

Sodium may, in this way, also be completely separated from ammonium, from cesium, rubidium and lithium, and

potassium from rubidium, cesium and lithium, while cesium may be separated from rubidium. In short, the group of alkali metals may be separated electrolytically with accuracy. The details for each of these separations are to be found in the *J. Am. Ch. S.*, 30, 1708-1711.

Finding that halides of the alkali metals were so readily analyzed in the manner outlined, and that the metals of that group were so easily separated, it was but a step to the application of the same procedure to the alkaline earth metals. The appended results were obtained, in this laboratory, by Hiram S. Lukens and Thos. P. McCutcheon, Jr.

Thus, on dissolving a definite amount of barium chloride in water and electrolyzing with a current of 0.3 ampere and 2.5 to 3 volts, it was discovered that as much as 0.2 gram of metal and its equivalent of halogen could be readily determined in from thirty to forty minutes.

EXAMPLES.

BARIUM PRESENT.	BARIUM FOUND.	CHLORINE PRESENT.	CHLORINE FOUND.
0.2277 gram	0.2276 gram .	0.1180 gram	0.1177 gram
	0.2274 "		0.1178 "
	0.2277 "		0.1181 "
	0.2278 "		0.1180 "
	0.2277 "		0.1180 "
	0.2277 "		0.1181 "

The bromide was used in the *determination of strontium*. The conditions were those used under barium chloride.

EXAMPLES.

STRONTIUM PRESENT.	STRONTIUM FOUND.
0.0727 gram	0.0725 gram
	0.0727 gram
	0.0727 gram
	0.0726 gram
	0.0725 gram

The barium and strontium amalgams passed freely into the outer dish and there quickly decomposed.

Upon electrolyzing a solution of pure *magnesium chloride* large quantities of magnesium hydrate were formed in the inner dish or compartment, while not a trace of magnesium could be detected in the outer compartment.

Mixtures of calcium chloride and magnesium chloride, consisting of one half as much magnesium as calcium or of equal amounts, gave like results. Not even traces of calcium or magnesium were found in the outer dish, provided the current did not exceed 3.5 to 4 volts.

Separation of Sodium from Calcium and Magnesium.

As the amalgams of calcium and magnesium decomposed so easily, it was thought that this separation could be made. Accordingly the chlorides of the three metals were dissolved in water and the solution placed in the inner dish. It was then exposed for a period of fifty minutes to the action of a current of 0.25 ampere and 3.5 volts.

Calcium present in grams.....	0.0222
Magnesium present in grams.....	0.0210
Sodium present in grams.....	0.0474
Sodium found in grams.....	0.0471
Sodium found in grams.....	0.0474
Sodium found in grams.....	0.0476
Sodium found in grams.....	0.0474

Separation of Potassium from Calcium and Magnesium.

Using like amounts of calcium and magnesium in the form of chlorides, and substituting potassium chloride for sodium chloride, while applying the same current as in the preceding separation, the following quantities of potassium were found in the outer dish:

GRAM.	GRAM.
0.0582	0.0579
0.0583	0.0580
0.0580	0.0580

The quantity of potassium present equaled 0.0580 gram.

Separation of Barium from Calcium and Magnesium.

Dissolve the chlorides in 30 cubic centimeters of water, add one drop of hydrochloric acid (1 : 10) to this solution and electrolyze with a current of 0.3 ampere and 3.5 to 4 volts for a period of seventy-five minutes.

EXAMPLES.

BARIUM PRESENT IN GRAMS.	CALCIUM PRESENT IN GRAMS.	MAGNESIUM PRESENT IN GRAMS.	BARIUM FOUND IN GRAMS.
0.0455	0.0222	0.0210	0.0456
"	"	"	0.0455
"	"	"	0.0454
"	"	"	0.0454

When calcium and magnesium are present together as chlorides their electrolysis leads to amalgam formation. These amalgams, however, decompose in the inner cell, forming hydroxides. Under such conditions, viz., the presence of magnesium and working with a pressure not exceeding 5 volts, the calcium is retained within the inner cell. The separation of barium from calcium and magnesium was thus made possible, as previously outlined. If, however, calcium chloride be subjected to a higher pressure (8 volts), it will be fully decomposed, the chlorine attaching itself to the silver-plated anode and the metal forming an amalgam, passing into the outer dish or compartment. Numerous determinations proved this.

Electrolysis of a Mixture of Barium, Calcium and Magnesium Chlorides.

Let the solution contain 0.0691 gram of barium, 0.0278 gram of calcium and 0.0220 gram of magnesium. Electrolyze the solution, after the anode has begun to rotate, with a pressure of 3.5 volts. In two hours the barium amalgam will have formed and completely decomposed to hydrate,

in the outer compartment. Titrate this hydrate, then increase the pressure to 9 volts, the current ranging from 0.30 to 0.02 ampere. In three hours the calcium will be completely removed to the outer cell, and may there be titrated with tenth normal acid. One illustration of the results from a solution, constituted as above indicated, showed the barium found to be 0.0691 gram, the calcium 0.0276 gram, leaving of course as residuum the quantity of magnesium originally added.

Consult also Coehn and Kettembeil, *Z. f. anorg. Chem.*, **38**, 198 to 212.

As the alkali metals had been separated (p. 305) by strict attention to differences in decomposition potentials it was thought that the same idea might be applied to the metals of the alkaline earths.

It was found on experiment that the decomposition potential of strontium chloride was 0.16 volt higher than that of barium chloride, while the decomposition value of calcium chloride, free from magnesium, was 0.13 volt higher than that of the corresponding strontium salt. Accordingly a neutral aqueous solution of barium and strontium chlorides was introduced into the inner compartment of the double cup. The circuit was closed and the pressure adjusted to and maintained at 0.07 volt above the decomposition pressure of the mixed chlorides. The barium passed into the mercury and the chlorine attached itself to the anode. Traces of the barium amalgam decomposed in the inner cup and to obviate this vitiating tendency the anode, when the decomposition was complete, was dipped into some of the standard hydrochloric acid solution used to titrate the barium hydroxide in the outer cup. The anode was then washed with distilled water and dried at 330° in an electric oven. The time required for the separation ranged from an hour and twenty-five to an hour and forty minutes.

Strontium may be similarly separated from calcium, although in these separations of the alkaline earth metals, only approximate values were obtained. See further Goldbaum and Smith, J. Am. Ch. S., 31, 900.

Separation of Strontium from Calcium and Magnesium.

Use the conditions given in the separation of barium from the same metals. Results like the following were obtained:

STRONTIUM PRESENT IN GRAMS.	STRONTIUM FOUND IN GRAMS.
0.0565	0.0563
0.0565	0.0565
0.0565	0.0564

Barium from Magnesium.

Use the chlorides in water solution. Let the current equal 0.3 ampere and 3.5 volts. The anode should perform 300 revolutions per minute. The current will not fall below 0.03 ampere, due to the traces of magnesium hydrate which have passed into solution. Several results show the accuracy of the method.

BARIUM PRESENT IN GRAMS.	MAGNESIUM PRESENT. IN GRAMS.	BARIUM FOUND IN GRAMS.
0.0455	0.0358	0.0455
0.0455	0.0358	0.0456
0.2277	0.0358	0.2277
0.2277	0.0358	0.2277

Strontium from Magnesium.

Use the same conditions as were employed in the preceding separation.

Barium from Iron.

Electrolyze the solution of the chlorides as neutral as possible with a current of 0.3 ampere and 3 to 5 volts for a period of fifty minutes. The iron amalgam decomposes at once within the inner compartment, forming ferric hy-

drate, while the barium amalgam passes into the outer cup and rapidly decomposes there. The results were most satisfactory.

Strontium, Potassium and Sodium may be similarly separated from **Iron**. The results in all instances were excellent.

Barium, Strontium, Potassium and Sodium were, with conditions like those given under barium from iron, separated most satisfactorily from **Aluminium**.

Sodium from Uranium.

Use the chlorides, apply a current of 3.5 volts and 0.3 to 0.02 ampere. The time is usually three hours. The chlorine collects on the silver-plated anode. The inner compartment will be filled with yellow colored uranium hydroxide which gradually assumes a black color. The sodium hydroxide, formed in the outer dish or compartment, should be titrated with tenth normal hydrochloric or sulphuric acid, using methyl orange as an indicator. Sometimes it is more convenient to remove the anode when the decomposition is finished, siphon out the liquid and the hydroxide formed there, wash out the inner compartment thoroughly with pure water, then pour the contents of the cell into a large beaker, and there make the titration without the slightest difficulty.

Potassium and lithium may be separated, under like conditions, from **uranium**. When making the separation of lithium use a current of 0.3 to 0.01 ampere and 5 volts. Time, one hour.

Barium from Uranium.

This separation may be made in one hour by employing a current of 1.5 to 0.01 amperes and 5 volts. It is well to add a definite volume of tenth normal hydrochloric acid to the water in the outer dish. Any barium hydroxide or carbonate that might form there is at once dissolved and

at the conclusion of the experiment it is only necessary to titrate the residual acid.

In separating **strontium** from **uranium** follow the preceding plan and use a current of 0.4 to 0.02 ampere and 5 volts. Two hours will suffice for the separation.

With a current varying from 0.4 to 0.01 ampere and a pressure of 4 to 5 volts, it is possible, using chlorides, to separate barium completely, in a period of two hours, from cerium, lanthanum, neodymium, thorium and titanium. The amalgams of the rare earth metals at once form hydroxides in the inner cell, while the barium amalgam, passing into the outer compartment, decomposes there. Consult also Kettembeil, *Z. f. anorg. Ch.*, 38, 213.

The Analysis of Sodium Sulphide.

Coat the platinum disks with cadmium, then carefully dry, weigh and suspend them in the aqueous solution of a known amount of sodium sulphide. Use a current of 0.1 to 0.03 ampere and 3.5 volts. In fifteen minutes the analysis will have been completed. At first the solution in the inner cup will assume a yellow color. After a few minutes, however, it will be colorless. In a sample containing 0.0253 gram of sulphur there was found:

0.0252 gram of sulphur
0.0252 gram of sulphur
0.0251 gram of sulphur

The deposit of cadmium sulphide is very adherent. It should be dried at about 115° C., before weighing.

In the analysis of alkaline fluorides the anode disks may be coated with calcium hydrate. On electrolyzing sodium fluoride the halogen will attach itself to the calcium hydrate on the anode, forming there an adherent layer of calcium fluoride. The alkali metal will pass out into the larger com-

partment of the cell, decomposing to hydroxide, and be there titrated. Numerous decompositions have been successfully made in this laboratory, but as the study is still in progress, this mere mention will be made here.

7. OXIDATIONS BY MEANS OF THE ELECTRIC CURRENT.

LITERATURE.—S m i t h , Ber., 23, 2276; Am. Ch. Jr., 13, 414; F r a n k e l , Ch. N., 65, 64.

When natural sulphides, *e. g.*, chalcopyrite, marcasite, etc., are exposed to the action of a strong current in the presence of a sufficient quantity of potassium hydroxide, their sulphur will be quickly and fully oxidized to sulphuric acid (Jr. Fr. Ins., April, 1889; Ber., 22, 1019). The metals (iron, copper, etc.) originally present in the mineral separate as oxides and metal on dissolving the fused alkaline mass in water. This method of oxidation eliminates many other disagreeable features of the old methods. Its rapidity and accuracy entitle it to the following brief description:—

Place about 20 grams of caustic potash in a nickel crucible $1\frac{1}{4}$ inches high and $1\frac{3}{8}$ inches wide. Apply heat from a Bunsen burner until the water has been almost entirely expelled, when the flame is lowered so that the temperature is just sufficient to retain the alkali in a liquid condition. The crucible is next connected with the negative pole of a battery, and the sulphide to be oxidized is placed upon the fused alkali. As some natural sulphides part with a portion of their sulphur at a comparatively low temperature, it is advisable to allow the alkali to cool so far that a scum forms over its surface before adding the weighed mineral.

The heavy platinum wire, attached to the anode, extends a short distance below the surface of the fused mass.

When the current passes, a lively action ensues, accompanied with some spattering. To prevent loss from this source, always place a perforated watch crystal over the crucible. After the current has acted for 10-20 minutes, interrupt it. When the crucible and its contents are cold, place them in about 200 c.c. of water, to dissolve out the excess of alkali and alkaline sulphate. Filter. Invariably examine the residue for sulphur by dissolving it in nitric acid and then testing with barium chloride. The alkaline filtrate is carefully acidulated with hydrochloric acid, and after digesting for some time is precipitated with a boiling solution of barium chloride. When the hydrochloric acid is first added, care should be taken to observe whether hydrogen sulphide or sulphur dioxide is liberated. If the oxidation is incomplete sulphur also makes its appearance as a white turbidity. The caustic potash employed in these oxidations should always be examined for sulphur and other impurities. As it is difficult to obtain alkali perfectly free from sulphur compounds, a weighed portion should be taken and its quantity of sulphur deducted from that actually found in the analysis.

The arrangement of apparatus employed in the oxidations just outlined is represented in Fig. 44. The crucible *A* is supported by a stout copper wire bent as indicated, and held in position by a binding screw attached to the base of a filter stand. The arm of the latter carries a second binding screw holding the platinum anode in position. While the platinum rod is generally the positive electrode, it is best to make it the negative pole for at least a part of the time during which the current acts. This is advisable because in many of the decompositions metals are precipitated upon the sides of the crucibles, and can readily enclose unattacked sulphide, so that by reversing the current (the poles) any precipitated metal will be detached, and the enclosed

sulphide be again brought into the field of oxidation. Cinnabar is a sulphide which has a tendency to mass together, and it could only be decomposed and its sulphur thoroughly

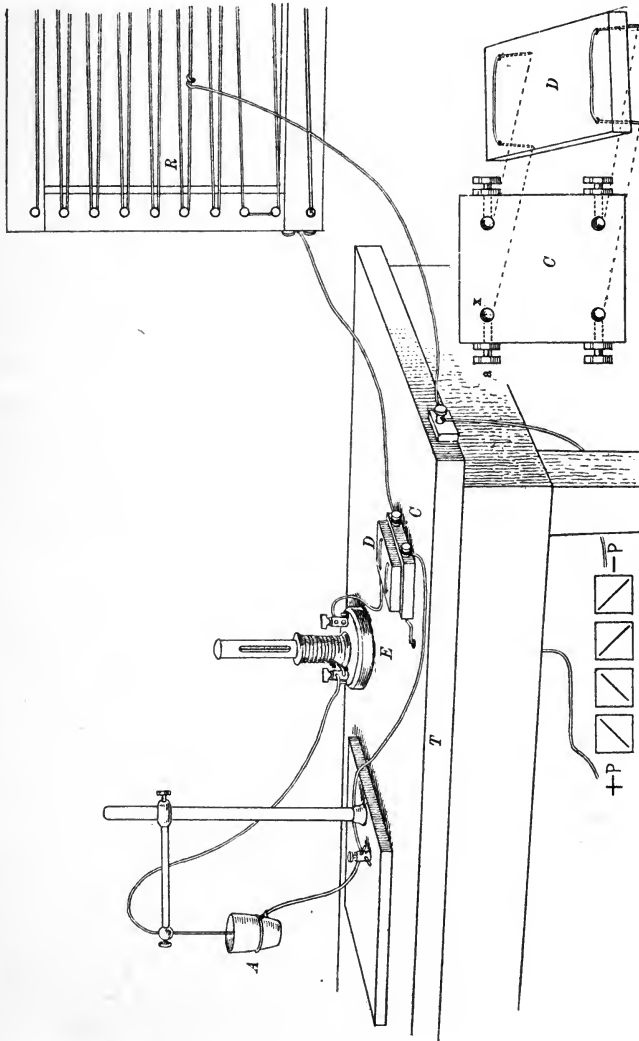

FIG. 44.

oxidized by reversing the current every few minutes. To reverse the current use the contrivance *C*; this is nothing more than a square block of wood fastened to the top of the table, *T*, by a screw or nail. The four depressions (*x*) in it contain a few drops of mercury, into which the side binding screws (*a*) project. The mercury cups are made to communicate with each other by a cap of wood, *D*, carrying two wires, which pass through it and project a slight distance on its lower side. By raising the cap and turning it so that the wires are vertical (\uparrow) or horizontal (\rightarrow), the crucible or the platinum wire extending into the fused mass can be made the anode or cathode in a few seconds. *E* is a Kohlrausch amperemeter and *R* the resistance frame (Fig. 6).

Storage batteries furnish the most satisfactory current for work of this character. In the sketch the cells stand beneath the table; the wire from the anode passes through a hole in the table-top, and is attached to one of the binding-posts of the block *C*, while the positive wire is attached to a binding-post at the end of the table-top, and from here it passes to the resistance frame, *R*, where it is fixed by an ordinary metallic clamp.

For most purposes the strength of current need not exceed 1-1.5 amperes; however, it may be necessary occasionally to increase it to 4 amperes. Pyrite, FeS_2 , is even then not completely decomposed. This particular case requires the addition of a quantity of cupric oxide equal in weight to the pyrite and a current of the strength last indicated before all of its sulphur is fully converted into sulphuric acid.

By increasing the number of crucibles it will be possible to conduct at least from four to six of these decompositions simultaneously, and by using a volumetric method of estimating the sulphuric acid, a sulphur determination can easily be executed in forty minutes.

Experience has demonstrated that 0.1–0.2 gram of material will require about 20–25 grams of caustic potash.

Frankel has conclusively demonstrated that the arsenic contained in metallic arsenides, *e. g.*, arsenopyrite, rammelsbergite, etc., can be entirely converted into arsenic acid by the above method. He recommends conditions analogous to those employed with the sulphides.

The current will also completely decompose the mineral chromite. For a quantity of material varying from 0.1–0.5 gram use from 30–40 grams of stick potash and a crucible slightly larger than that recommended in the oxidation of sulphides and arsenides. The current should not exceed one ampere. Thirty minutes will be sufficient for the oxidation. At the expiration of this period allow the mass to cool, take up in water, filter off from the iron oxide, acidulate the filtrate with sulphuric acid, add a weighed quantity of ferrous ammonium sulphate, and determine the excess of iron with a standardized bichromate solution, using potassium ferricyanide as an indicator. Upon oxidizing 0.4787 gram of chromite by the above process 51.77 per cent. of chromic oxide was obtained, while a second sample of the same mineral, oxidized by the Dittmar method, gave 51.70 per cent. of chromic oxide. If the chromium be estimated volumetrically, the chromium content in a chrome ore may be ascertained in less than an hour.

8. THE COMBUSTION OF ORGANIC COMPOUNDS.

LITERATURE.—Carrasco, R. Acc. d. Lincei (5), 14, 608; Taylor, Thesis (Johns Hopkins University, 1905).

For the combustion of organic bodies Carrasco employs an ordinary combustion tube in which there is heated a wire

FIG. 45.

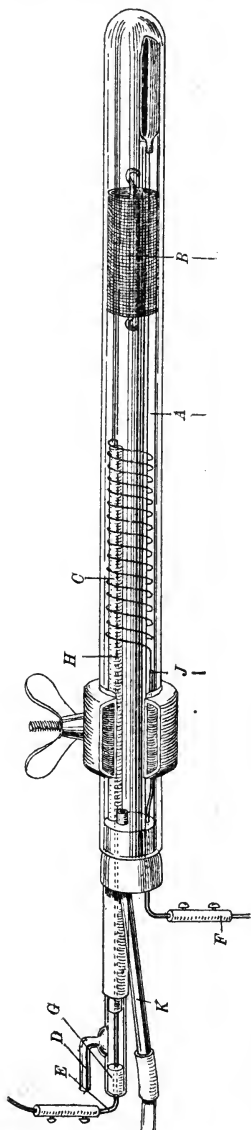

of platinum-iridium. An atmosphere of oxygen is maintained throughout the entire experiment which usually occupies not more than fifteen minutes. The device of Taylor in its simplest form is seen in Fig. 45. "It consists of a thin glass combustion tube *A* closed at one end, 300 mm. in length and 15 mm. in internal diameter. Through the rubber stopper in its open end there pass: (1) the porcelain tube *C*, which has a length of 250 mm. and a diameter of 6 mm.; (2) the glass tube *K*, through which the products of combustion enter the absorption apparatus; (3) the rather stout platinum wire, which extends from *F* to *J*. The porcelain tube *C* is joined outside of the stopper, by means of rubber tubing, to the branched glass tube *D*. The latter is provided with a stopper, *G*, through which passes the platinum wire *E*, which extends into the porcelain tube to the point *H*, where it is joined to a smaller platinum wire. The small wire has a length of about 1.75 meters and weighs, approximately, 2.5 grams. It extends from its junction with the larger wire at *H*, through the porcelain tube to the inner end of the latter and then returns on the outside, in a series of suspended coils, to the point *J*, where it joins the larger wire *F*. Thicker wire is used from *F* to *J* and from *E* to *H* in order

to avoid any overheating of the rubber stopper by the current. The roll of copper wire gauze *B*, about 60 mm. in length, is inserted between the end of the porcelain tube and the boat containing the substance to be burned.

“The coil is prepared by first heating the wire, while stretched slightly, either by passing it through a flame or by connecting its ends with electric terminals and passing a current through it. The danger of the former method, which is obviated by the latter, is that the wire will have its resistance changed at some one spot by being drawn out there through uneven heating. This also serves the purpose of straightening the wire and removing some of the temper, making it easier to wind. It is then wound upon a screw thread of such size that the coil will have an approximate diameter of 9 mm. During the winding the tension of the wire should be kept as nearly constant as possible. After all the wire has been placed upon the thread it may be easily removed by turning the screw, the wire being held firmly by the fingers. From this method an even coil should result which is ready to be placed upon the porcelain stem for use. After the wire has been used for a few combustions it loses its temper and the coil can then be reformed by simply winding it around a glass rod of the proper diameter.

“The heavy wire from *J* to *F* is sharpened at one end and with a pair of forceps forced through the rubber stopper. By regulating its length in the combustion tube the coils may be brought so near the end that all the moisture will be driven over and yet not near enough to burn the stopper. The longer wire from *H* to *E*, forming the second terminal, is passed through the stopper in the branched tube *D* at *G* and the end of the tube filled with sealing-wax. The second end of the branched tube is slipped over the end of the porcelain tube and closed with thick rubber tubing tied with waxed shoemaker's thread.

“The pure oxygen or air enters the apparatus at *D* and while passing over the portion of the small wire which is within the porcelain tube has its temperature raised more or less according to the rate of its flow. It is, therefore, already hot when it enters the tube *C*, where the combustion is to be effected. The completeness of the combustion is probably due, to a large extent, to the temperature to which the oxygen is heated before it comes in contact with the vapors to be burned. This hot oxygen is also of especial advantage not only in keeping the roll of copper gauze next to the porcelain tube thoroughly oxidized at all times, but in heating the roll to such a temperature that it can be acted upon readily by the vapors of the substance to be burned. The excess of oxygen and the products of the combustion of the substance pass together over the heated coils on the outside of the porcelain tube, completing the burning of any unoxidized material coming from the rear.

“The coils are supported by unglazed porcelain tubes. They are very durable and they are not hygroscopic to an appreciable degree.

“The roll of copper wire gauze, *B*, while not absolutely necessary has some advantage because much less care is required in the management of the combustion with it than without it. If the substances are liquids, or if they readily yield large quantities of inflammable vapors when heated, it must be inserted between the material and the end of the porcelain tube through which the oxygen enters.

“The combustion is conducted in the following manner:

“Having placed, in the positions indicated in the figure, the boat containing the material and the roll of copper wire gauze (which, in the beginning, may or may not be oxidized) and having joined the tube *K* to the usual train of absorption apparatus, a slow current of dry and purified oxygen is admitted and the electric circuit is closed through a regulat-

ing rheostat. Starting with a current of about one ampere the flow is gradually increased, at the rate of 0.2 ampere every two or three minutes, until the coils assume a bright red color or until 3.6 amperes are reached. While the coils are being heated a lamp having a broad, thin flame is brought under the roll of copper wire gauze and raised gradually until the blue portion of the flame touches the glass tube on its under side. The substance in the boat is then heated with the same lamp, or with another which is held in the hand. The rate of heating and the flow of oxygen are so regulated with respect to each other that at least one half of the roll of wire gauze is kept in the oxidized condition during the entire combustion. After the formation of volatile products has ceased, the reoxidation of the copper progresses rapidly and the oxygen enters the rear compartment, burning any residue of carbon upon the boat or upon the glass.

“Having finished the combustion of the substance, the current of oxygen is replaced by one of dried and purified air, and the flow of the latter continued until the products of the combustion have all been expelled from the space behind the wire gauze. It is here that a miscalculation is likely to be made. The time required for the complete removal of these products depends, principally, upon the freedom of diffusion through the gauze, and for this reason it should not be rolled too tightly.

“The apparatus, already described, is adapted to the combustion of those solids and liquids which consist of carbon and hydrogen, or of carbon, hydrogen and oxygen.

“The heating of the roll of wire gauze *B*, and, at times, of the substance also, is facilitated by inverting over the tube, at a little distance above it, a trough of asbestos board, the side of a trough, at the back, being much deeper than in front. This arrangement is supported in its position by a

rod, which is inserted in a heavy block, resting upon the work table behind the tube. The device is also of advantage in protecting the tube from draughts of cold air during the combustion and during the subsequent cooling period. The portion of the glass tube which is occupied by the porcelain tube and the platinum wire is protected, on the bottom, by a semicircular strip of asbestos board which is inserted in the clamp between the lower jaw and the glass. To protect the upper portion of the tube in the same region, a semicircular trough of mica is inverted over it, behind the clamp, in such a manner that the lower edges of the mica rest in the trough below. The mica is made to keep its curved form by fastening it to narrow strips of metal and bending the latter to the required shape.

“The cooling of the tube requires some care. The current should be reduced quite gradually, following the reverse of the heating process, and it is well, also, as soon as the combustion is finished, to cover the portion of the glass tube which is beyond the porcelain one with the soot from a smoky flame and to take any other measures for the protection of the tube which will contribute toward the proper annealing of the glass. Care must likewise be taken never to allow the platinum coils to come in contact with the glass either while heating or cooling the tube, since, in the former case, the metal is likely to stick to the glass, while in the latter, the tube is quite sure to crack at some lower temperature. Further, the coils, after being used for some time, show a tendency to increase in size towards the end of the porcelain tube, and, if they approach too nearly the inner diameter of the combustion tube, the wire must be taken out and rewound. The difficulty of keeping the coils away from the glass while they were hot, led to the placing upon the inner end of the porcelain tube of a small platinum disk. The porcelain tube was ground down at the end until it was

practically square and the disk, which was a little smaller than the internal diameter of the combustion tube, was fitted eccentrically upon it so that the coils were held the same distance from the glass tube at all points. Small holes were drilled in the disk to allow the free passage of the vapors. As the small wire of the coils only comes in contact with the platinum disk at one point it does not heat the latter hot enough to affect the glass tube injuriously. The porcelain tube and coils are thus always kept in the same relative position to the glass tube while the combustion is not in any way interfered with. With the proper care a good piece of glass tubing can be used for a large number of combustions.

“The time required for a combustion does not, ordinarily, exceed half an hour, and it may be reduced to twenty minutes, or even less, if the substance to be burned is of such a character that the roll of wire gauze can be dispensed with. Its omission is not, however, recommended at any time, except to those who have had some experience with the method.

“At the highest temperature employed during the combustion (at a bright red, but not a white heat), especially when the wire is new, there is a sensible volatilization of the platinum. This volatilization of platinum in an atmosphere of oxygen, even at comparatively moderate temperatures, has been repeatedly noticed by others. The volatilized metal settles upon the surface of the glass and porcelain tubes as a dark deposit, which, at first, may be mistaken for carbon. The presence of such films of volatilized platinum upon the inner surface of the tube is, of course, by its catalytic action, of some assistance in the combustion.

“The objections to and difficulties in the use of the short, closed combustion tube represented in Fig. 45 are wholly obviated by using a somewhat longer tube which is open at both ends, as represented in Fig. 46. In this arrangement

FIG. 46.

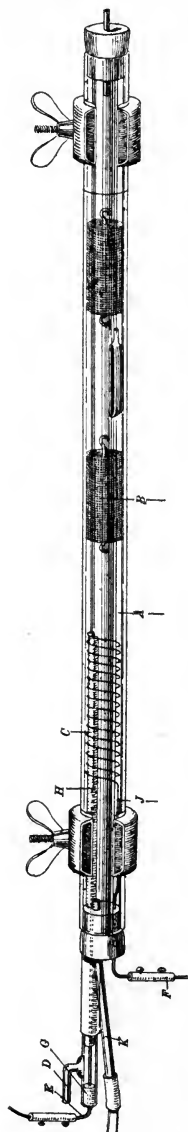

the boat is introduced from the rear and there is placed behind it a second roll of copper wire gauze, about 60 mm. in length. The stopper in the front end of the combustion tube, the forward roll of copper wire gauze and also the apparatus as a whole, are never disturbed. Each roll of wire gauze is heated by a lamp giving a broad, thin flame and there is inverted over both rolls and the space between them the asbestos shield already described. The lamps should be raised until the bottom of the tube is just within the blue region of the flames. To prevent any sagging of the combustion tube while hot, it is supported at a point beneath the end of the porcelain tube by a forked or notched standard, which is placed under the asbestos trough in which the front portion of the apparatus lies.

“The combustion is conducted in the same manner as in the short, closed tube, except that a slow current of oxygen or air is admitted from the rear during the entire experiment. This prevents any accumulation of volatilized matter in the back part of the tube and aids in the expulsion of the products of combustion from the space occupied by the boat.

“If the substance to be burned is very volatile, it is advisable to introduce air and not oxygen in the rear, and to employ, behind the boat, a roll of gauze which is only partially oxidized. In this way the vapors of the substance may be diluted with nitrogen to any desired extent.

“With this apparatus a Marchand tube, filled with calcium chloride, is used to absorb the water vapors formed, because the end of the tube can be placed directly in the stopper of the combustion tube, thus doing away with the connection tube *K*. No trouble is experienced with this arrangement in getting the water vapor ready to weigh by the time the combustion is completed. When the Marchand tube is removed from the absorption train its ends are closed by small pieces of rubber tubing carrying glass plugs.

“The clamp at the rear is required only as a support and it should not grip the tube so tightly as to prevent the free movement of the latter, back and forth through the former.

“In the following determinations of carbon and hydrogen in cane-sugar, which were made for the purpose of testing the method, the short, closed tube was employed and the roll of wire gauze was omitted. A clay tobacco pipe stem served for the introduction of oxygen and the effect of its use is evident in the high percentages of hydrogen which were obtained in the first four analyses. In the last two analyses, in which normal quantities of hydrogen were obtained, the pipe stem was thoroughly burned out in a current of oxygen before beginning the combustion:

WEIGHT OF SUGAR. GRAM.	CARBON FOUND. PER CENT.	HYDROGEN FOUND. PER CENT.	TIME OCCUPIED IN COMBUSTION. MINUTES.
0.1364	41.95	6.86	25
0.1188	42.03	6.63	18
0.1227	42.03	6.65	18
0.1382	42.07	6.73	18
0.1154	42.11	6.47	18
0.2809	42.03	6.46	45
	Theoretical, 42.09	Theoretical, 6.47	

“The current at the highest temperature was 2.6 amperes at 48 volts. In these combustions a coil of No. 32 wire (B. & S. gauge) was used, but, as is stated later, it was found

advisable to exchange this, in the combustions of naphthalene, for a greater length of larger wire.

“Careful management is required, even in the combustion of such substances as sugar, when the roll of wire gauze is omitted. On several occasions, when it was attempted to reduce the time consumed in combustion to fifteen minutes or less, small explosions occurred. To avoid the explosions, which always resulted in unburned material escaping, the combustion tube was lengthened slightly and the previously mentioned roll of wire gauze was inserted between the boat and the end of the porcelain tube. Combustions of toluene and two of naphthalene were made with the modified apparatus with the following results:

TOLUENE.

WEIGHT OF SUBSTANCE. GRAM.	CARBON FOUND. PER CENT. .	HYDROGEN FOUND. PER CENT.	TIME OCCUPIED IN COMBUSTION. MINUTES.
0.1057	90.91	8.62	35
0.0650	91.25	8.80	35
	Theoretical, 91.24	Theoretical, 8.76	

NAPHTHALENE.

WEIGHT OF SUBSTANCE. GRAM.	CARBON FOUND. PER CENT.	HYDROGEN FOUND. PER CENT.	TIME OCCUPIED IN COMBUSTION. MINUTES.
0.1184	93.54	6.36	55
0.1252	93.49	6.39	55
	Theoretical, 93.70	Theoretical, 6.36	

The Combustion of Substances Containing Nitrogen.

“For the determination of carbon and hydrogen in compounds containing nitrogen, there are placed in the combustion tube: (1) a roll, 100 mm. in length, of wire copper gauze which has been reduced in the usual way by methyl alcohol;

(2) a roll, 80 mm. in length, of wire gauze which has been well oxidized; (3) the boat containing the substance; (4) a short roll of wire gauze also well oxidized.

“During the combustion each of the three rolls is heated by a burner giving a broad, thin flame, the last lamp serving also for heating the substance. The portion of the tube occupied by the copper is covered with a screen of asbestos board, to insure a sufficiently high temperature for the reduction of the nitric oxide. The flow of the oxygen through the porcelain tube is so regulated that only about one-quarter of the copper roll (1) is oxidized, while at the rear it is admitted as rapidly as may be necessary to keep a portion of the second roll (2) at all times in an oxidized condition.

The Combustion of Halogen Compounds.

“To prepare the apparatus for the analysis of substances containing the halogens, a piece of silver foil, about 50 mm. in width, is rolled up with a sheet of thick paper, which is afterwards withdrawn. The silver roll is placed in the tube quite close to the end of the porcelain tube and is not directly heated during the combustion. In other respects the arrangements are the same as for the combustion of non-nitrogenous compounds. A roll of well-oxidized copper wire gauze follows the one of silver, then the boat containing the substance and, finally, a second roll of oxidized copper wire gauze.

“During the combustion there is formed a quantity of fusible cuprous-halogen salt, which deposits itself, more or less, upon the inner surface of the glass tube, but does not, at any time, get beyond the silver foil into the space occupied by the porcelain tube and platinum wire. On cooling, the cuprous-halogen salt, in accordance with the well-known behavior of such compounds, absorbs large quantities of oxygen, only to give it up again when the apparatus is reheated in a succeeding experiment. At the same time the

copper wire, in the oxidized rolls, grows thinner and becomes quite brittle.

“The quantity of cuprous salt accumulates, after a few combustions, to such an extent that the time required for its oxidation is considerable. Hence, it is well frequently to cleanse the combustion tube and to renew, at the same time, the oxidized rolls of copper wire gauze.

The Combustion of Sulphur Compounds.

“The determination of carbon and hydrogen in compounds containing sulphur presents no difficulty. The only change which it is necessary to make in the simple arrangement for non-nitrogenous and non-halogen compounds, in order to adapt the method to the combustion of sulphur compounds, is to substitute lead chromate for the roll of oxidized copper wire gauze which is nearest the end of the porcelain tube. Instead of maintaining the lead chromate in its position in the tube by means of plugs of asbestos or of wire gauze, it has been found more convenient and better for the glass tube to introduce it in the form of a cartridge. This is prepared by filling, with the loose, granular chromate, a shell made from very fine copper wire gauze.”

INDEX

- Accumulator, 2
Alkali metals, separation of, 305
Alkaline earth metals, separation of, 309
Ammeters, 8, 16
Ammonium salts, analysis of, 304
Ampere, 7
Amperemeter, 8
Anions, 1
 determination of, 285, 289, 292
Anode, 1, 10
 dish, 78
 spiral, 78
Antimony, determination of, 174
 rapid precipitation of, 179
 separation from arsenic, 251
 bismuth, 225
 copper, 185
 lead, 233
 mercury, 216
 silver, 238
 tin, 251
Arsenic, determination of, 182
 oxidation of, 317
 separation from antimony, 251
 bismuth, 225
 cadmium, 207
 copper, 186
 lead, 234
 mercury, 216
 silver, 238
 tin, 254
Barium, determination of, 306
 separation from calcium and mag-
 nesium, 308
 iron, 310
 magnesium, 310
 uranium, 311
Battery, Bunsen, 9
 storage, 2, 11
Bismuth, determination of, 99
 rapid precipitation of, 102
 with mercury cathode, 103
 separation from aluminum, 225
 antimony, 225
 arsenic, 225
 barium, 225
 cadmium, 225
 calcium, 226
 chromium, 226
 cobalt, 227
 copper, 227
 gold, 228
 iron, 228
 lead, 229
 magnesium, 230
 manganese, 230
 mercury, 217
Bismuth, separation from molybdenum,
 230
 nickel, 230
 palladium, 231
 platinum, 231
 potassium, 231
 selenium, 231
 silver, 231
 sodium, 231
 strontium, 231
 tellurium, 231
 tin, 232
 tungsten, 232
 uranium, 232
 vanadium, 232
 zinc, 232
Board, distributing, 13
 switch, 13
Bromine, determination of
 in sodium bromide, 296, 301
 in hydrobromic acid, 304
 separation from chlorine, 288
 iodine, 288
Bunsen cell, 9
Cadmium, determination of, 86
 rapid precipitation of, 89
 with mercury cathode, 93
 separation from alkali and alka-
 line earth
 metals, 207
 aluminum, 205
 antimony, 206
 arsenic, 207
 beryllium, 207
 bismuth, 207
 chromium, 207
 cobalt, 207
 copper, 208
 gold, 208
 iron, 208
 lead, 234
 magnesium,
 207, 209
 manganese, 210
 mercury, 218
 molybdenum,
 211
 nickel, 211
 osmium, 212
 selenium, 212
 silver, 239
 tellurium, 212
 tin, 212
 tungsten, 213
 uranium, 213
 vanadium, 213
 zinc, 213

- Cathode, 1
mercury, 60
- Cations, 1
determination of, 292
- Cesium chloride, analysis of, 305
- Chlorine, determination of
in sodium chloride, etc., 295 *et seq.*
in hydrochloric acid, 303
- Chromite, oxidation of, 317
- Chromium, determination of, 148
mercury cathode, 149
separation from aluminum, 273
beryllium, 274
- Cobalt, determination of, 126
rapid precipitation of, 134
with mercury cathode, 137
separation from bismuth, 227
cadmium, 207
copper, 190
iron, 261
manganese, 266
mercury, 218
nickel, 266
silver, 239
uranium, 268
zinc, 267
- Combustion of organic compounds, 317
- Copper, determination of, 69
rapid precipitation of, 78
with mercury cathode, 82
separation from alkali metals, 187
aluminum, 183
antimony, 185
arsenic, 186
barium, strontium,
calcium, and
magnesium, 187
bismuth, 227
cadmium, 188
chromium, 189
cobalt, 190
gold, 247
iron, 191
lead, 194
magnesium, 195
manganese, 195
mercury, 219
molybdenum, 196
nickel, 197
palladium, 198
platinum, 198
selenium, 199
silver, 199, 240
tellurium, 200
thallium, 200
tin, 200
tungsten, 203
uranium, 203
vanadium, 203
zinc, 203
- Current, action upon compounds, 1
density, 10
electric light, 2
measuring of, 8
reduction of, 4
separations, 7
- Decomposition pressure, 31
- Determination of metals, 69
- Distributing board, 13
- Dynamos, 2
- Electric current, sources of, 2
- Electric light current, 2
motor, 101
- Electro-chemical laboratory, 11
- Electrode, auxiliary, 279
graphite, 52
- Electrolysis defined, 1
- Electrolyte, 1
- Galvanometer, 8
- Gold, determination of, 165
rapid precipitation of, 166
with mercury cathode, 168
separation from antimony, 246
arsenic, 249
cadmium, 246
cobalt, 247
copper, 247
iron, 248
molybdenum, 249
nickel, 248
osmium, 249
palladium, 248
platinum, 249
tungsten, 249
zinc, 249
- Halogen compounds, combustion of, 327
- Halogens, determinations of, 285, 292
separation of, 287
- Historical account, 18
- Indium, determination of, 154
with mercury cathode, 155
- Iodine, determination of, 285
separation from bromine, 288
separation from chlorine, 288
- Ions, 1
complex, 32
- Iron, determination of, 142
rapid precipitation of, 146
with mercury cathode, 146
separation from aluminum, 255
beryllium, 257
bismuth, 228
cadmium, 208
cerium, 260
chromium, 261
cobalt, 261
copper, 191
lanthanum, 259
lead, 234
manganese, 262
mercury, 220
neodymium, 260
nickel, 263
phosphoric acid, 265
praseodymium, 260
silver, 243
thorium, 259
titanium, 265
uranium, 265
vanadium, 257
yttrium, 261
zinc, 265
zirconium, 261
- Laboratory, electro-chemical, 11
- Lead, determination of, 104
rapid precipitation of, 107
with mercury cup, 107

- Lead**, separation from the alkali metals, barium, beryllium, cadmium, calcium, cobalt, iron, magnesium, nickel, uranium, zinc, and zirconium, 234
aluminium, 233
antimony, 233
arsenic, 234
bismuth, 229
copper, 234
gold, 235
manganese, 235
mercury, 220
nickel, 236
selenium, 236
silver, 236
tellurium, 237
tin, 237
- Lithium chloride**, analysis of, 305
- Magnesium chloride**, electrolysis of, 307
- Magneto-machines**, 2
- Manganese**, determination of, 138
rapid precipitation of, 141
separation from bismuth, 230
cadmium, 210
cobalt, 266
copper, 195
iron, 262
mercury, 221
nickel, 268
zinc, 269
- Measuring currents**, 8
- Mercury**, determination of, 94
rapid precipitation of, 97
with mercury cathode, 99
separation from alkali metals, 217
aluminium, 215
antimony, 216
arsenic, 216
barium, 217
bismuth, 217
cadmium, 218
calcium, 218
chromium, 218
cobalt, 218
copper, 219
gold, 220
iron, 220
lead, 220
magnesium, 221
manganese, 221
molybdenum, 221
nickel, 221
osmium, 222
palladium, 222
platinum, 222
selenium, 222
silver, 222
strontium, 222
tellurium, 223
tin, 223
tungsten, 224
uranium, 224
vanadium, 224
zinc, 224
- Metals**, separation of, 183
additional remarks on separation of, 274
- Molybdenum**, determination of, 164
rapid precipitation of, 164
with mercury cathode, 164
separation from cadmium, 221
mercury, 221
silver, 244
vanadium, 272
- Nickel**, determination of, 126
rapid precipitation of, 131
with mercury cathode, 133
separation from the alkali metals, 267
aluminium, 267
bismuth, 230
cadmium, 217
chromium, 269
cobalt, 266
copper, 197
iron, 263
lead, 236
magnesium, 267
manganese, 268
mercury, 221
rare earths, 268
silver, 244
tin, 269
titanium, 268
uranium, 269
zinc, 268
- Nitric acid**, determination of, 289
rapid determination of, 289
- Nitrogen compounds**, combustion of, 326
- Normal density** defined, 10
- Organic compounds**, combustion of, 317
- Osmium**, 183
- Oxidations by means of the current**, 313
- Palladium**, determination of, 157
rapid precipitation of, 158
separation from copper, 198
gold, 248
iridium, 157
mercury, 222
- Phosphoric acid**, separation of, 265
- Platinum**, determination of, 155
rapid precipitation of, 156
separation from copper, 198
gold, 249
iridium, 250
mercury, 222
silver, 244
metals, 250
- Pole pressure**, 10
- Potassium ferricyanide**, analysis of, 302
ferrocyanide, analysis of, 302
separation from alkali metals, 305
calcium and magnesium, 307
iron, 311
uranium, 311
sulphocyanide, analysis of, 296
- Potential across poles**, 10
- Precipitation of metals**, rapid, 39
with use of filtering crucibles, 55
- Resistance coils and frames**, 4-8
- Rheostats**, 4, 8, 17, 281

- Rhodium, determination of, 159, 250
 rapid precipitation of, 160
- Rotating anode, 39
 mercury cathode, 60, 292
 cathode, 46, 55
- Rubidium chloride, analysis of, 305
- Separation, constant current, 37
 of metals, 183, 274
- Silver, determination of, 108
 rapid precipitation of, 111
 with mercury cathode, 112
 separation from aluminium, 237
 antimony, 238
 arsenic, 238
 barium, 238
 bismuth, 238
 cadmium, 239
 calcium, 239
 chromium, 239
 cobalt, 239
 copper, 240
 gold, 243
 iron, 243
 lead, 243
 lithium, 243
 magnesium, 243
 manganese, 244
 mercury, 244
 molybdenum, 244
 nickel, 244
 osmium, 244
 palladium, 244
 platinum, 244
 potassium, 245
 selenium, 245
 sodium, 245
 tellurium, 245
 tin, 245
 tungsten, 244
 uranium, 246
 zinc, 246
- Sodium bromide, analysis of, 296, 301
 carbonate, analysis of, 302
 chloride, analysis of, 295
 iodide, analysis of, 296
 separation from alkali metals, 305
 aluminium, 311
 calcium and magnesium, 307
 iron, 311
 uranium, 311
 sulphide, analysis of, 312
- Storage cells, 2, 11
- Strontium, determination of, 306
 separation from calcium and magnesium, 310
 iron, 311
 magnesium, 310
 uranium, 312
- Sulphur compounds, combustion of, 328
 oxidation of, 313
- Switchboard, 13
- Table, working, 17
- Tellurium, 181
- Thallium, determination of, 152
- Theoretical considerations, 30
- Thermopile, 2
- Tin, determination of, 168
 rapid precipitation of, 171
 with mercury cathode, 173
 separation from antimony, 251
 arsenic, 254
 bismuth, 232
 cadmium, 212
 copper, 200
 lead, 237
 manganese, 255
 mercury, 223
 pickel, 269
- Tri-sodium phosphate, analysis of, 303
- Tungsten, 183
- Uranium, determination of, 150
 rapid precipitation of, 151
 separation from alkali metals, 311
 barium, 271, 311
 calcium, 271
 magnesium, 272
 strontium, 312
 zinc, 272
- Vanadium, 183
- Voltmeter, 8
- Voltmeter, 8
- Working Table, 17
- Zinc, determination of, 113
 rapid precipitation of, 120
 with mercury cathode, 123
 separation from aluminium, 270
 bismuth, 232
 cadmium, 213
 copper, 203
 iron, 265
 lead, 234
 manganese, 269
 mercury, 224
 nickel, 268
 silver, 246
 titanium, 270
 uranium, 269





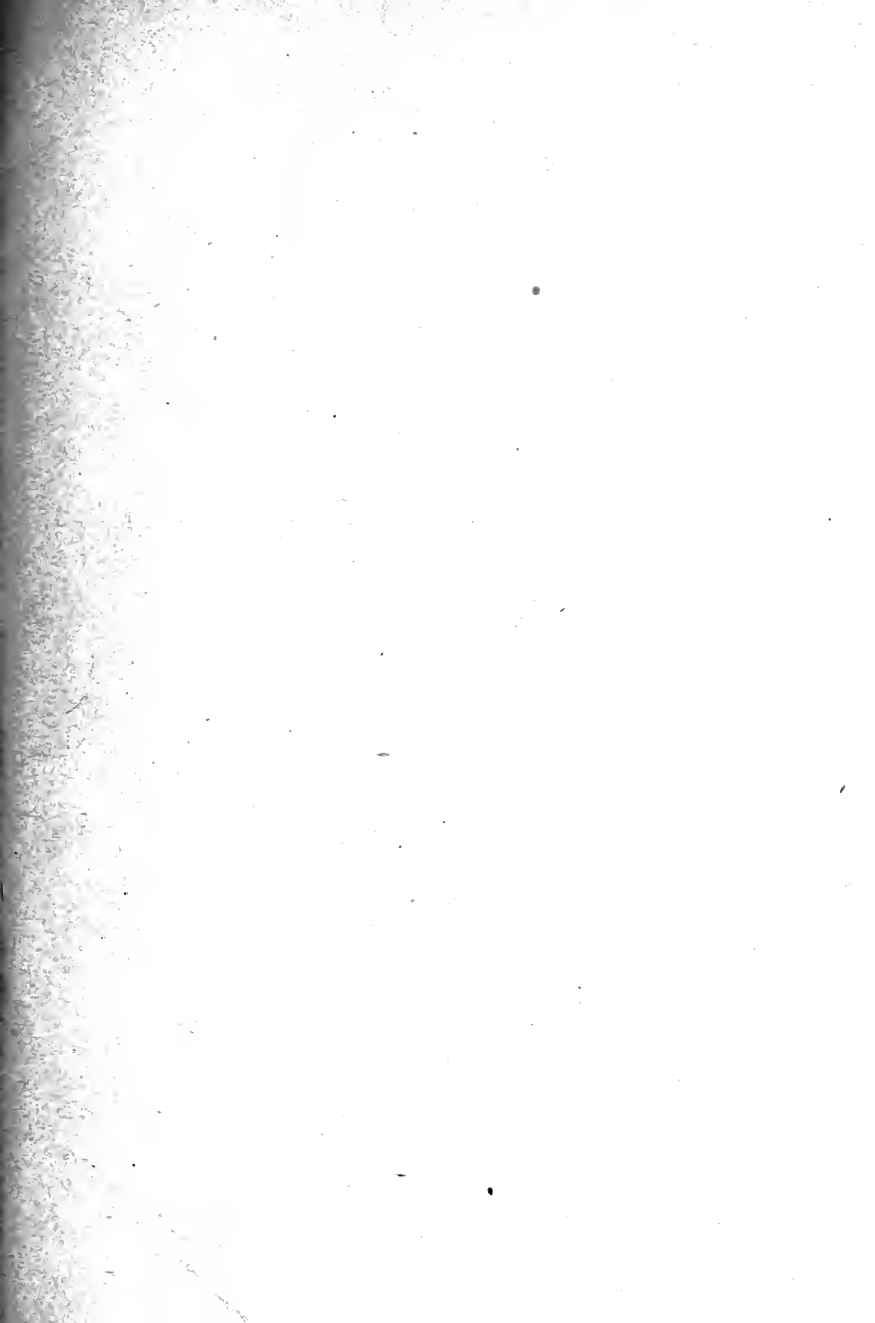

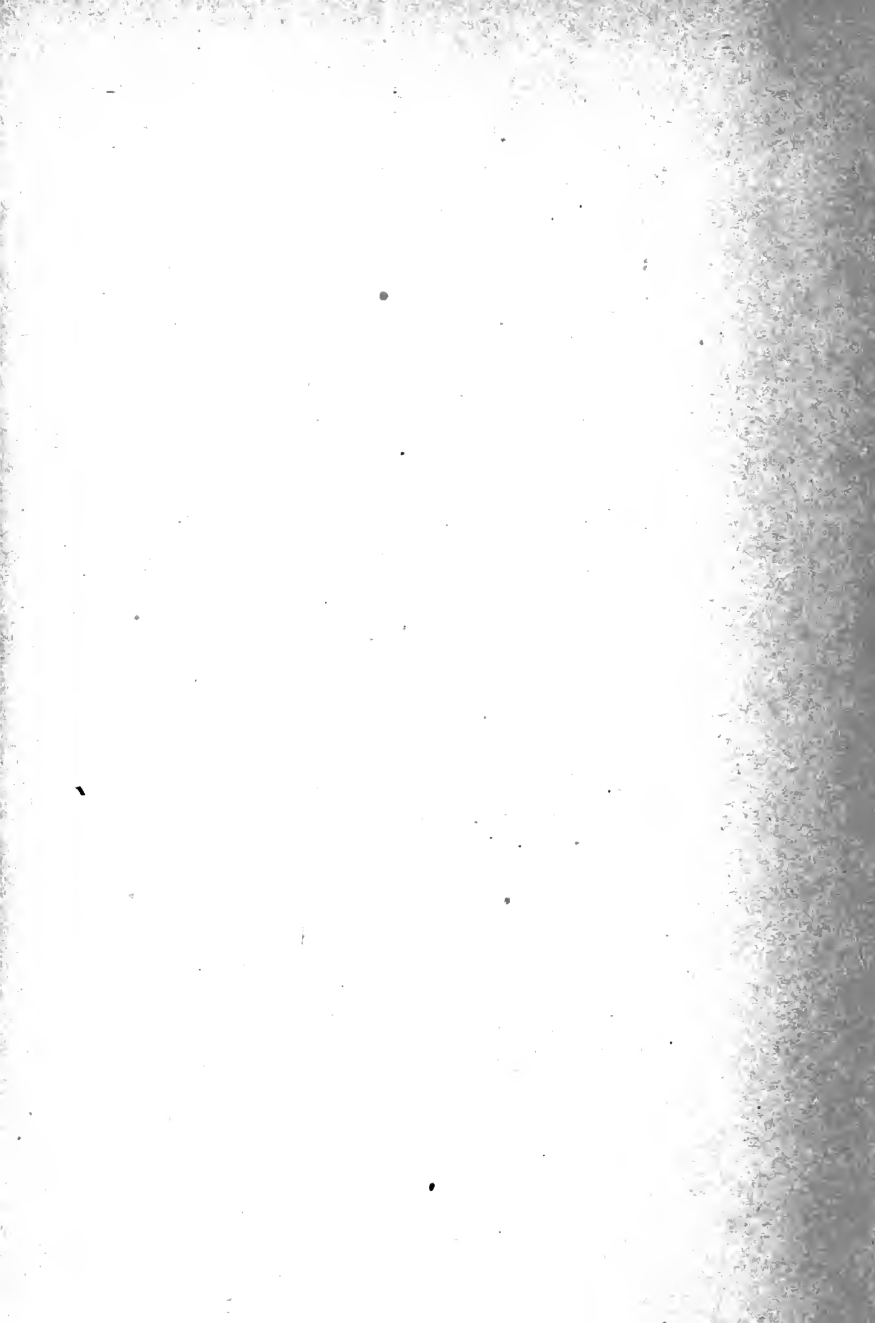

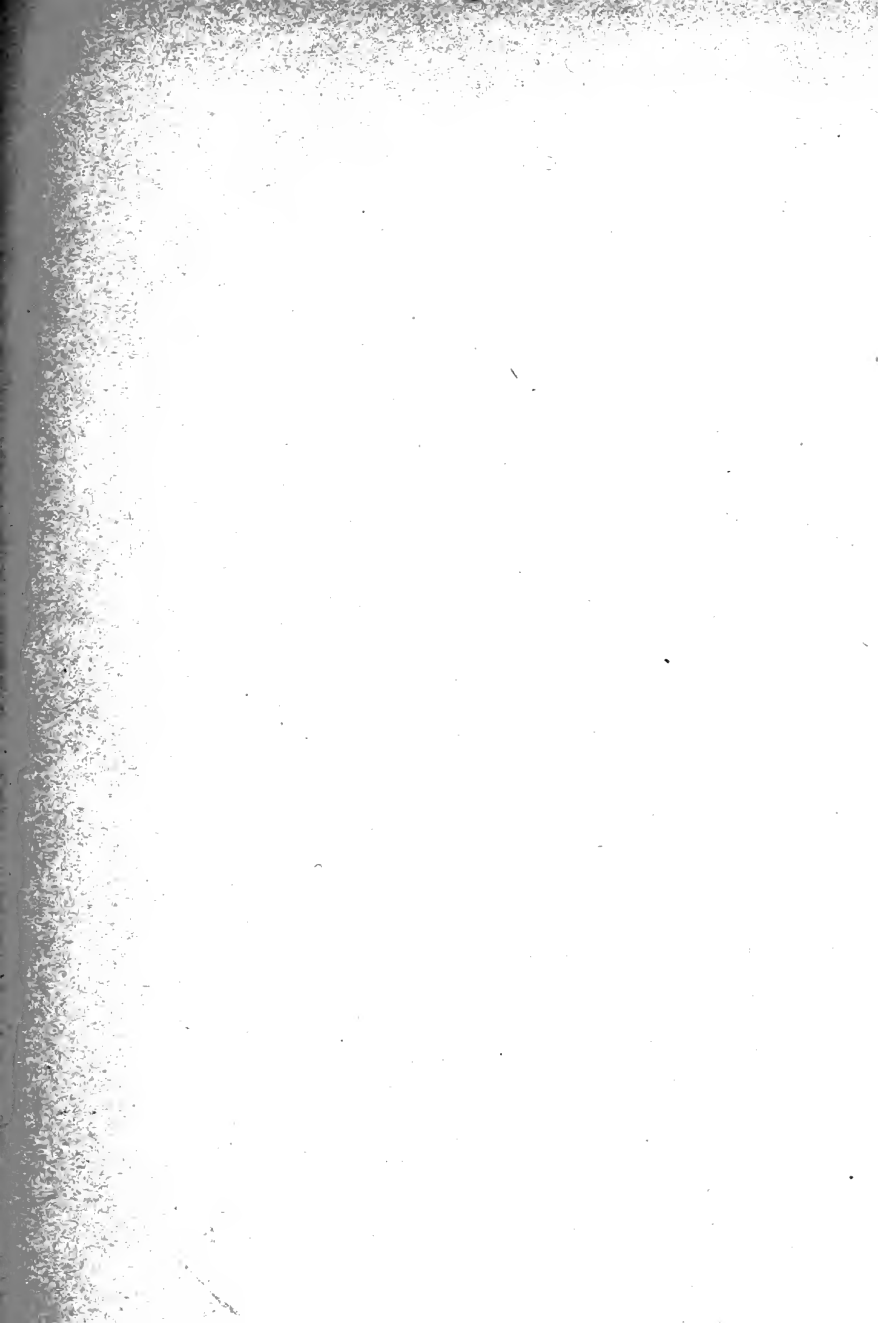

QD115

Smith, E.F.

40934

S64

Electro-analysis. 5th ed.

1912

Handwritten mark

40934

