

UC-NRLF

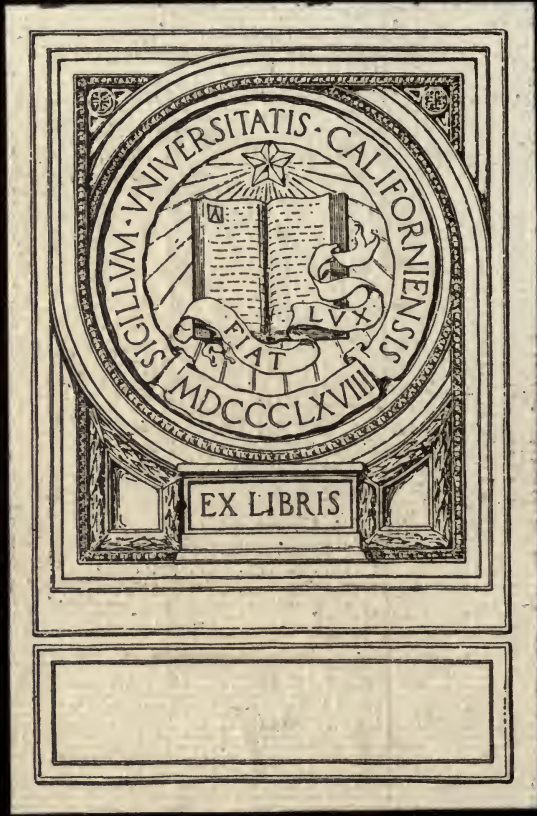

LB 26 017



EX LIBRIS

ELEMENTARY CAMS

BY

FRANKLIN DE RONDE FURMAN, M. E.

Professor of Mechanism and Machine Design
at Stevens Institute of Technology

Member of American Society of Mechanical Engineers

FIRST EDITION
FIRST THOUSAND

UNIVERSITY OF
CALIFORNIA

NEW YORK
JOHN WILEY & SONS, INC.
LONDON: CHAPMAN & HALL, LIMITED
1916

TJ206
F8

Copyright, 1916, by
FRANKLIN DE RONDE FURMAN

THE
PUBLISHERS
PRINTING COMPANY

PUBLISHERS PRINTING COMPANY
207-217 West Twenty-fifth Street, New York

PREFACE

WITH the constant introduction of automatic machinery in practically the whole range of manufacturing industry, the matter of form and size of the cam calls strongly for a comprehensive method of technical analysis. Such analysis becomes more and more important as the automatic devices or machines are designed to operate at higher and higher speeds.

Of the vast number of cams in use, in industrial manufacturing plants particularly, it is quite certain that a large majority have been formed entirely "by eye" as a result of experience and successive trials and without recourse to technical analysis or computation. The entire development of cam work has been practically individualistic without a common thread of principle running through it all. This is in sharp contrast to the technical development of the subject of toothed gearing, for example. Cams, considered on a scientific basis, have been more neglected in engineering books than any other of the important branches of mechanism. Even the nomenclature of the subject is in a chaotic state, and the same types of cams are known by various names in different localities—some of them not far apart.

This book on Elementary Cams has been prepared with a view to gathering the various types of cams that are in common use in some comprehensive and orderly manner, and then pointing out how to design one of each class by selecting the form that will come nearest to giving the desired velocity and acceleration to the follower. Simple arithmetical computations are made in advance to determine the size of the cam necessary to avoid "hard spots" when in service. The present work includes practically all of the base curves that are in common use in industrial manufacturing work, and will enable the cam designer to lay down his plans with a foreknowledge of what may be expected in each case.

F. DER. FURMAN.

HOBOKEN, N. J., November, 1916.

CONTENTS

PAGES

SECTION I.—DEFINITIONS AND CLASSIFICATION 1-19

Cams Follower Surfaces Radial or Disk Cams Side or
Cylindrical Cams Conical and Spherical Cams

Names of Cams—Periphery, Plate, Heart, Frog, Mushroom, Face,
Wiper, Rolling, Yoke, Cylindrical, End, Double End, Box, Internal,
Offset, Positive Drive, Single Acting, Double Acting, Step, Adjustable,
Clamp, Strap, Dog, Carrier, Double Mounted, Multiple Mounted,
Oscillating

Definitions of Terms Used in the Solution of Cam Problems—Cam
Chart, Cam Chart Diagram, Time Chart, Base Curve, Base Line,
Pitch Line, Pitch Circle, Pitch Surface, Working Surface, Pitch Point,
Pressure Angle

Formula for Size of Cam for a Given Maximum Pressure Angle

Table of Cam Factors for All Base Curves for Maximum Pressure
Angles from 20° to 60°

**SECTION II.—METHOD OF CONSTRUCTION OF BASE CURVES IN COMMON
USE 20-24**

Straight Line Base Straight-Line Combination Curve Crank
Curve Parabola Elliptical Curve

SECTION III.—CAM PROBLEMS AND EXERCISE PROBLEMS 25-74

Problem 1, Empirical Design Problem 2, Technical Design.
Advantages of Technical Design Problem 3, Single-Step Radial
Cam, Pressure Angle Equal on Both Strokes Omission of Cam
Chart Problem 4, Single-Step Radial Cam, Pressure Angles Unequal
on Both Strokes

Pressure Angle Increases as Pitch Size of Cam Decreases Change
of Pressure Angles in Passing from Cam Chart to Cam Cam Con-
sidered as Bent Chart. Base Line Angles Before and After Bending

Limiting Size of Follower Roller Radius of Curvature of Non-
Circular Arcs

Problem 5, Double-Step Radial Cam Determination of Maximum
Pressure Angle for a Multiple-Step Cam

Problem 6, Cam with Offset Roller Follower Problem 7, Cam
with Flat Surface Follower Limited Use of Cams with Flat Surface
Followers

Problem 8, Cam with Swinging Follower Arm, Roller Contact—
Extremities of Swinging Arc on Radial Line Problem 9, Cam
with Swinging Follower Arm, Roller Contact—Swinging Arc, Con-
tinued, Passes Through Center of Cam Effect of Location of
Swinging Follower Arm Relatively to the Cam

	PAGES
Problem 10, Face Cam with Swinging Follower	Problem 11, Cam
with Swinging Follower Arm, Sliding Surface Contact	Data Limited
for Followers with Sliding Surface Contact	
Problem 12, Toe and Wiper Cam	Modifications of the Toe and
Wiper Cam	
Problem 13, Single Disk Yoke Cam	Limited Application of
Single Disk Yoke Cam	Problem 14, Double Disk Yoke Cam
Problem 15, Cylindrical Cam with Follower that Moves in a Straight	
Line	Refinements in Cylindrical Cam Design
Problem 16,	Cylindrical Cam with Swinging Follower
Chart Method for Laying	Out a Cylindrical Cam with a Swinging Follower Arm
Exercise Problems, 1a to 16a	
 SECTION IV.—TIMING AND INTERFERENCE OF CAMS	 75-78
Problem 17, Cam Timing and Interference	Location of Keyways
Exercise Problem 17a	
 SECTION V.—CAMS FOR REPRODUCING GIVEN CURVES OR FIGURES	 79-87
Problem 18, Cam Mechanism for Drawing an Ellipse	Problem
18a, Exercise Problem for Drawing Figure 8	Problem 19, Cam
for Reproducing Handwriting Using Script Letters	Ste
Method of Subdividing Circles into Any Desired Number of Equal	
Parts	

ELEMENTARY CAMS

SECTION I.—DEFINITIONS AND CLASSIFICATION

DEFINITIONS

1. CAMS are rotating or oscillating pieces of mechanism having specially formed surfaces against which a follower slides or rolls and thus receives a reciprocating or intermittent motion such as cannot be generally obtained by gear wheels or link motions.

Various forms of cams are illustrated at *C* in Figs. 1 to 10. The follower in each case is shown at *F*, all having roller contact except the ones shown in Figs. 7 and 8. The former has a *V* edge and the latter a plane surface in contact with the cam and both have sliding action.

2. FOLLOWER EDGES OR ROLLERS may have motion in a straight line as from *D* to *G*, Fig. 7, or in a curved path depending on suitably constructed guides or on swinging arms. The total range of travel of the follower may be accomplished by one continuous motion, or by several separate motions with intervals of rest. Each motion may be either constant or variable in velocity, and the time used by the motion may be greater or less, all according to the work the machine has to do and to the will of the designer.

CLASSIFICATION

3. Cams may be most simply, and at the same time most completely, classified according to the motion of the follower with respect to the axis of the cam, as:

(a) RADIAL OR DISK CAMS, in which the radial distance from the cam axis to the acting surface varies constantly during part or all of the cam cycle, according to the data. The follower edge or roller moves in all cases in a radial, or an approximately radial, direction with respect to the cam. Various forms of radial cams are illustrated in Figs. 1, 2, 7, 8, and 9.

(b) SIDE OR CYLINDRICAL CAMS, in which the follower edge or roller moves parallel to the axis of the cam, or approximately in

this direction. Several types of side cams are shown in Figs. 3, 4, and 10.

Nearly all the cams referred to in the above figures illustrating the two general classes of radial and side cams respectively have special or local trade names which will be pointed out in a succeeding paragraph.

(c) CONICAL and (d) SPHERICAL cams, in which the follower edge or roller moves in an inclined direction having both radial and longitudinal components with respect to the axis of the cam as illustrated in Figs. 5 and 6.

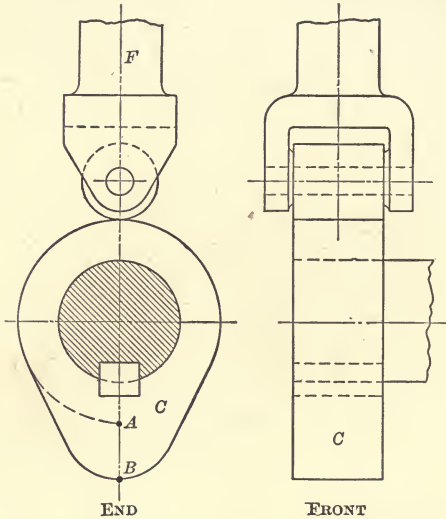

FIG. 1.—RADIAL CAM AND FOLLOWER,
ROLLER CONTACT

4. NAMES OF CAMS.

Cams, in popular usage, have come to be known by a wide range of names, the same cam often being designated by a number of different names according to geographical location and personal preference and surroundings of the cam builder or user. This is an unfortunate condition, and in the general classification in the preceding paragraph an endeavor is made to establish a fund-

amental basis for clarifying and simplifying the nomenclature of cams as much as possible. In a treatise of this kind, however, it is essential that, at least, the more common of the ordinary working terms be recognized and defined, and that the cams under their popular names be properly placed in the fundamental classification given in the preceding paragraph.

The following specially named cams fall under the classification of radial cams:

(e) PERIPHERY CAMS, in which the acting surface is the periphery of the cam, as illustrated in Figs. 1, 7, and 9. While these are examples of true periphery cams, it must be recorded that the cylindrical grooved cam, shown in Fig. 3, is also known to some extent as a periphery cam, due no doubt to the fact that in designing this

cam the original layout for the contour of the groove is first made on a flat piece of paper, which is then wrapped on to the surface or "periphery" of the cylinder. Since the contour line of the groove which lies on the periphery is merely a guiding line for cutting the groove, and since the side surface of the groove is the working surface, it is, to say the least, a misnomer to designate such a cam as a periphery cam.

(f) **PLATE CAMS**, in which the working surface includes the full 360° , and forms either the periphery of the cam, or the sides of a

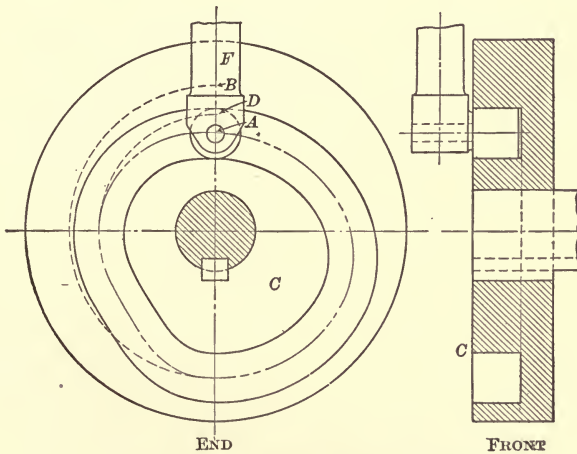

FIG. 2.—FACE CAM AND FOLLOWER

groove cut into the face of the cam plate, as illustrated in Figs. 1 and 2 respectively. Figs. 7 and 9 also show plate cams.

(g) **HEART CAMS**, in which the general form is that which the name implies. See Fig. 7. In this type of cam there are two distinct symmetrical lobes, often so laid out as to give uniform velocity to the driver. In this case each lobe would be bounded by an Archimedean spiral with the ends eased off.

(h) **FROG CAM**, in which the general form includes several lobes more or less irregular, as illustrated, for example at *C* in Fig. 9.

(i) **MUSHROOM CAM**, in which the periphery of a radial or disk cam works against a flat surface, usually a circular disk at right angles to the cam disk, instead of against a roller, see Fig. 44.

(j) **FACE CAM**, also called a Groove, but more properly a Plate Groove cam, to distinguish it from the Cylindrical Groove cam, in which a groove is cut into the flat face of the cam disk. In

this form of cam shown in Fig. 2 the roller has two opposite lines of contact, one against each side of the groove, when the roller has a snug fit. The plate or disk in which the groove is cut is generally circular; but it may be cast to conform with the contour of the groove, or it may be built with radial arms supporting the irregular grooved rim. In the latter case it lacks resemblance to the face

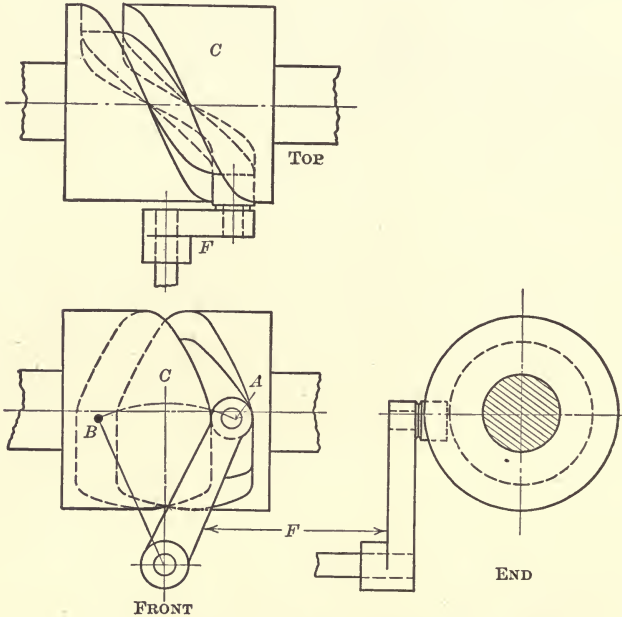

FIG. 3.—CYLINDRICAL CAM AND SWINGING FOLLOWER

cam, but nevertheless it must, because of the nature of its action, be classed with it. The face cam, as ordinarily considered and as illustrated in Fig. 2, is better adapted for higher speeds because of its more nearly balanced form of construction. Against this, however, must be considered one of two disadvantages, either the high rubbing velocity of the roller against one side of the groove when the roller is a snug fit, or lost motion and noise as the working line of contact changes from one side of the groove to the other when the roller has a loose fit. The most important advantage of the face cam, that of giving positive drive, will be considered in paragraph 9. The term groove cam might be applied, with advantage in clearness of meaning, to such face cams as are cut or cast on non-circular plates.

(k) **WIPER CAM**, which has an oscillating motion, and is constructed usually with a long curved arm in order that it may "wipe" or rub along the plane surface of a long projecting "toe," or follower. The wiper cam is used generally to give motion to a follower which moves straight up and down as shown from F to F' in Fig. 8. This, however, is not essential and the follower may also have a swinging

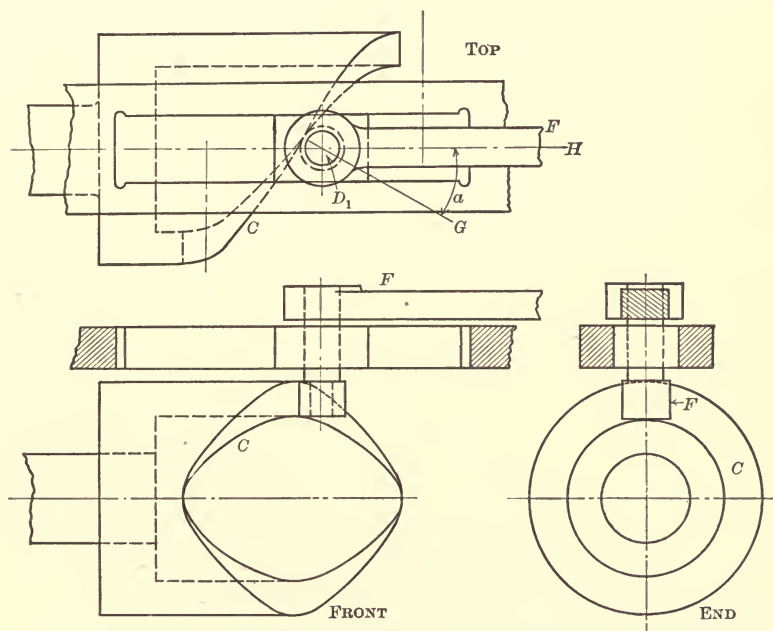

FIG. 4.—END CAM AND FOLLOWER

motion. The disadvantage of sliding friction, which is inseparable from the wiper cam, is balanced to some extent by the fact that the very sliding permits, within certain range, of the assignment of specified intermediate velocities between the starting and stopping points which cannot be obtained with similar forms of cams which have pure rolling action.

(l) **ROLLING CAM**, which greatly resembles the wiper cam in general appearance, but which is totally different in principle, for the curves of the cam and follower surfaces are specially formed so as to give pure rolling action between them. The rolling cam is specially well adapted to cases where both driver and follower have an oscillating motion and where the velocities between the starting and stopping points are not important and are not specified.

(*m*) **YOKE CAM**, a form of radial cam in which all diametral lines drawn across the face and through the center of rotation of the cam are equal in length. This form of cam permits the use of two opposite follower rollers whose centers remain a fixed distance apart, to roll simultaneously on opposite sides of the cam, and thus give positive motion to the follower. For illustration, see Fig. 9.

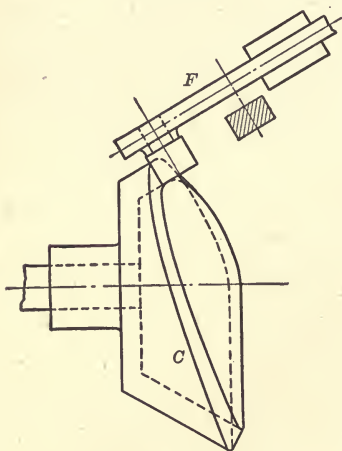

FIG. 5.—CONICAL CAM AND RECIPROCATING FOLLOWER

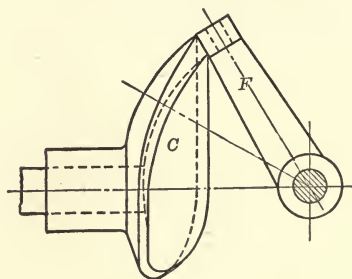

FIG. 6.—SPHERICAL CAM AND SWINGING FOLLOWER

Yoke cams may be, and frequently are, made of two disks fixed side by side, the peripheries being complementary to each other and the two rollers of the yoke rolling on their respective cam surfaces, as shown in Fig. 56. The advantage of yoke cams is that they give positive motion with pure rolling of the follower roller, there being contact on only one side of the roller in contradistinction to the double contact of the roller which exists in face and groove cams.

5. The following specially named cams fall under the general classification of side cams.

These include cams that have been made from blank cylindrical bodies by using a rotary end cutter with its axis at right angles to the axis of the cylinder and by moving the axis of the rotary cutter parallel to the axis of the cylinder while the cylinder rotates. A groove of desired depth is thus left in the cylinder, Fig. 3, or the end of a cylindrical shell is thus milled to a desired form, Fig. 4. A side cam may also be formed by screwing a number of formed

clamps on to a blank cylinder, the sides of the clamps thus acting as the working surface as illustrated in Fig. 11. All types of side cams may properly be considered as derived from blank cylindrical forms, and, therefore, the name "cylindrical cam" could be regarded as synonymous with side cam; but general custom has limited the use of the term cylindrical cam to the "barrel" or "drum" type mentioned below:

(n) **CYLINDRICAL CAM**, also called Barrel cam, Drum cam, or Cylindrical Groove cam, in which the

groove, cut around the cylinder, affords bearing surface to the two opposite sides of the follower roller, thus giving positive motion, as illustrated in Fig. 3.

(o) **END CAM**, in which the working surface has been cut at the end of a cylindrical wheel, thus requiring outside effort such as a spring or weight to hold the follower roller against the cam surface during the return of the follower. An end cam is shown in Fig. 4.

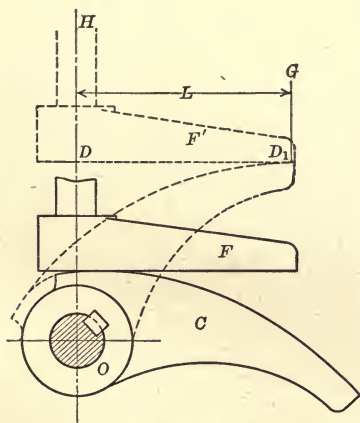

FIG. 8.—TOE AND WIPER CAM

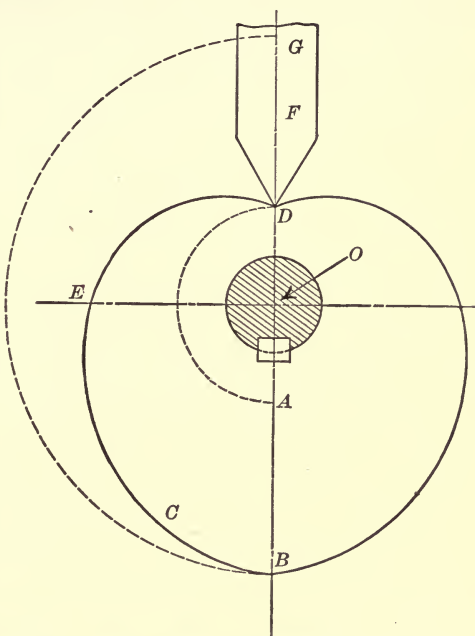

FIG. 7.—HEART CAM AND FOLLOWER, SLIDING CONTACT

(p) **DOUBLE END CAM**, in which a projecting twisted thread has been left on a cylindrical body, against both sides of which separate rollers on a follower arm may operate, and thus secure positive motion. Instead of cutting down a cylinder to leave a projecting twisted thread, it may be cast integral with a

warped plate, as illustrated in Fig. 10, but this in no way changes its characteristic action.

There are a number of names in common use for cams, that cover both radial and side cams. Most prominent in this connection are those mentioned in paragraphs 6 to 14.

6. **BOX CAM**, which designates a cam in which the follower roller is encased between two walls as in the face cam, Fig. 2, or the cylindrical cam, Fig. 3. Literally, box cams would also include yoke cams, in which the yoke would be the "box." Box cams, because of their form of construction, give a positive drive in all cases.

7. **INTERNAL CAM**, in which there is only one working surface, and this is outside of the pitch surface. The internal cam corresponds to the internal gear wheel in toothed gearing. It may also be considered as a face cam with the inside surface of the groove removed, thus requiring that the follower roller should always be in pressure contact on the outside surface of the groove by means of a spring or weight, etc. Under some conditions of structural arrangements of the cam machine, the internal cam may be used to advantage where it will give a positive motion to a follower on the opposite stroke to that of the periphery cam; and it will also sometimes

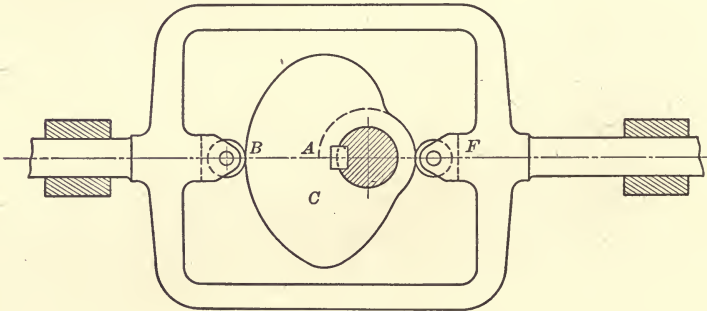

FIG. 9.—YOKE CAM

permit of a larger roller than the periphery cam, as explained in paragraphs 56 and 62.

8. **OFFSET CAM**, in which the line of action of the follower, when extended, does not pass through the center of the cam, see Fig. 43.

9. **POSITIVE-DRIVE CAM** is one in which the cam itself drives the follower on the return as well as the forward motion. Most

cams drive only on the forward motion of the follower and depend upon gravity or the action of a spring to drive the follower in its return motion; such cams are illustrated in Figs. 1, 4, 5, 6, 7, and 8. Cams having positive drive, and therefore independent of gravity or springs, are illustrated in Figs. 2, 3, 9, and 10. It will be noted that positive-drive cams include the face, yoke, cylindrical, and double-end types of cams; also that the box cam, although it includes some of these, should also be considered as a group name of the positive-drive type.

10. SINGLE-ACTING AND DOUBLE-ACTING CAMS comprise all forms of cams, the single-acting ones giving motion only in one direction and depending on a spring or gravity to return the follower. Double-acting cams have the follower under direct control all the time and are the same as positive-drive cams described in the preceding paragraph.

11. STEP CAMS. Cams which give continuous motion to the

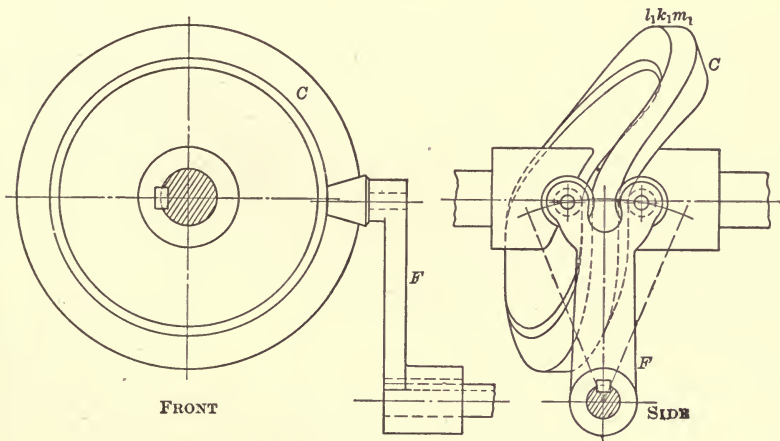

FIG. 10.—DOUBLE-END CAM

follower from one end of the stroke to the other are called single-step cams. When the follower's motion in either of its two general directions is made up of two entirely separate movements it is called a double-step cam with reference to that stroke. If three or more separate movements are given to the follower while it moves in one general direction it is generally referred to as a multiple step cam, or as a triple-step, quadruple-step cam, etc. Since a cam may be, for example, a double-step cam on the out or working stroke, and

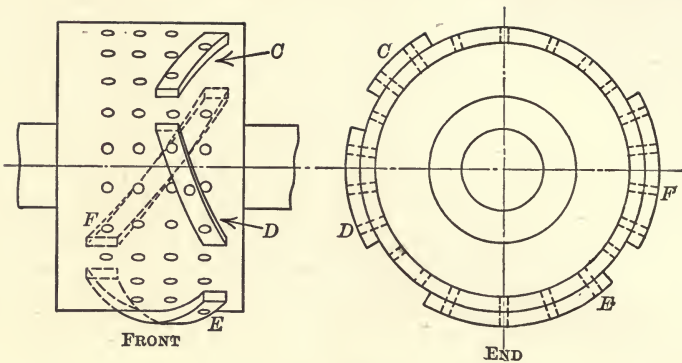

FIG. 11.—BARREL CAM

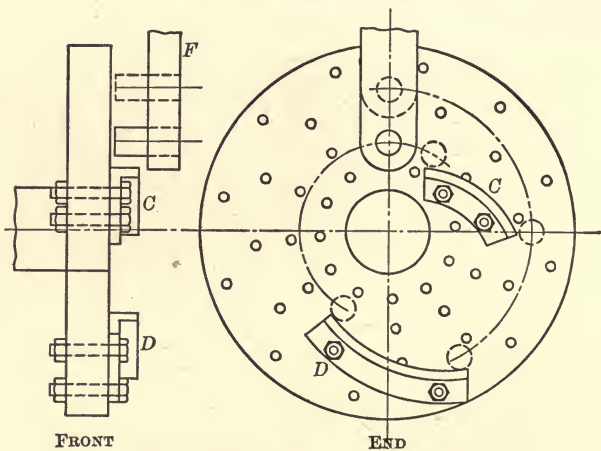

FIG. 12.—ADJUSTABLE PLATE CAM

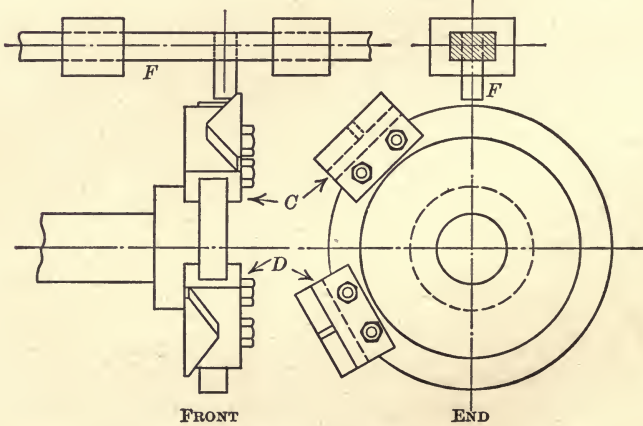

FIG. 13.—DOG CAM

a single-step cam on the return stroke, such a cam may be referred to as a two-one step cam, always giving the number referring to the working stroke first.

12. ADJUSTABLE CAM, ALSO CALLED CLAMP CAM, STRAP CAM, DOG CAM, AND CARRIER CAM, in which specially formed pieces are directly bolted or clamped to any of the regular geometrical surfaces, usually to either the plane or cylindrical surfaces. In Fig. 12 the clamps are shown at *C* and *D* fastened to a disk. The cam, considered as a whole, belongs to the radial class. In Fig. 13 the clamps are shown at *C* and *D*, also fastened to a disk, but in this case the clamps, or dogs, as they are usually called when used in this way, are so formed as to give a sidewise motion to the follower, and therefore this cam belongs to the side cam class. In Fig. 11 clamps are shown at *C*, *D*, *E*, and *F* fastened to a cylinder, and they are shaped to give the same action as a regularly formed end-cam in the side-cam class. The type of cam illustrated in Fig. 11 is also known as an adjustable cylindrical or "barrel" or "drum" cam and is very widely used for regulating the feeding of the stock, and in operating the turret in automatic machines for the manufacture of screws, bolts, ferrules, and small pieces generally that are made up in quantities.

13. DOUBLE-MOUNTED OR MULTIPLE-MOUNTED CAMS are sometimes resorted to where several movements can be concentrated into small space. This consists merely in placing two or more of any of the cam surfaces described in the preceding paragraphs on one solid casting or cam body. For example, a face cam, a cylindrical, and an end cam may all be cut on one piece.

14. OSCILLATING CAMS, in which the cam itself turns through a fraction of a turn instead of through the entire 360° . While any type of cam may be designed to oscillate instead of rotate, it is usually the toe-and-wiper and rolling forms of the radial type of cam that are known as oscillating cams. With oscillating cams the follower may move forth and back on a straight line, or it may oscillate also.

15. Cams falling in the conical class have no special name other than the one here used. The spherical cams are sometimes termed globe cams. Cams in conical and spherical classes are particularly useful in changing direction of motion in close quarters and in directions other than at right angles. In both Figs. 5 and 6, end action of the cam is shown, but it is apparent that with thicker walls on both the cone and the sphere, grooves could be cut in them, thus giving positive driving cams in both cases.

16. Summing up the general and special names for cams we have in tabular form:

Cams	}	Box	}	a	Radial or Disk	e	Periphery
		Internal				f	Plate
		Offset				g	Heart
		Positive Drive				h	Frog
Single Acting	}	b	Side, or Cylindrical	i	Mushroom		
Double Acting				j	Face or Plate Grooved		
Step				k	Toe and Wiper		
Adjustable or Strap				l	Rolling		
Dog or Carrier	}	c	Conical	m	Yoke or Duplex		
Multiple Mounted				n	Cylindrical, Grooved, Barrel, or Drum		
Oscillating				o	End		
				p	Double End		
		d	Spherical or Globe				

DEFINITIONS OF TERMS USED IN THE SOLUTION OF CAM PROBLEMS

17. CAM CHART. Illustrated in Fig. 14. The chart is a rectangle the height of which is equal to the total motion of the follower in one direction, and the length equal to the circumference of the pitch circle of the cam. The chart length represents 360° and is sub-

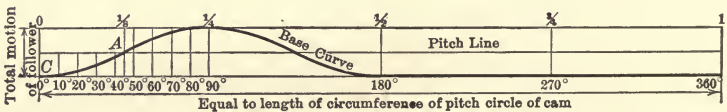

FIG. 14.—CAM CHART

divided into equal parts marking the 5°, 10° . . . points, or the 1/8, 1/4 . . . points, or any other convenient subdivision, according to the requirements of the problem. On the cam chart are drawn the base curve and the pitch line. The former becomes the pitch surface of the cam and the latter the pitch circle.

18. CAM CHART DIAGRAM. Illustrated in Fig. 15. The cam chart diagram is a rectangle, the height of which represents the total motion of the follower in one direction. The length of the diagram represents the circumference of the pitch circle of the cam.

In the cam chart diagram the scales for drawing the height and the length of the rectangle are totally independent of each other and independent also of the scale of the cam drawing. In drawing the diagram no scale need be used at all, and the entire chart diagram with its base curve and pitch line may be drawn entirely freehand with suitable subdivisions marked off entirely "by eye" according to the requirements of the problem. The base curve may be drawn roughly as a curve or it may be made up of a series of straight lines. The cam chart diagram frequently serves all the purposes of the cam chart. It saves time, and permits of chart drawings being

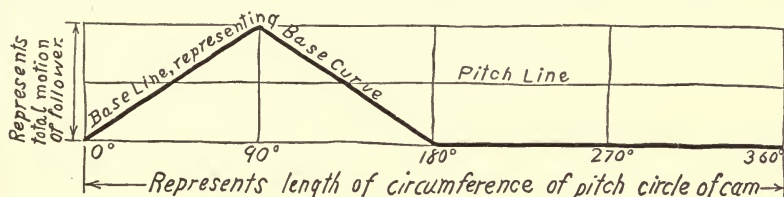

FIG. 15.—CAM CHART DIAGRAM

made on small available sheets of paper, whereas the more precise cam chart often requires large sheets of paper which are usually impracticable in academic or exercise problems.

19. TIME CHARTS. Illustrated in Figs. 16 and 17. Time charts are the same as cam charts or cam chart diagrams, and are constructed in the same way as described in the two preceding paragraphs. The term "time chart," however, is most appropriately applied to problems where two or more cams are used in the same machine and where their functions are dependent on each other.

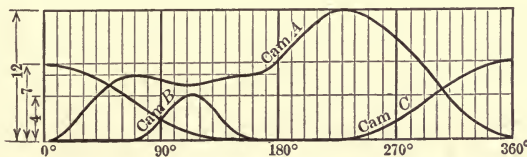

FIG. 16.—TIME CHART DIAGRAM, BASE CURVES SUPERPOSED

The time chart permits of allowances being made for avoiding possible interference of the several moving parts, and for the desired timing of relative motions for each part. The time chart contains two or more base curves according to the number of cams used. When the base curves are superposed as in Fig. 16, the time chart consists of a single rectangle whose height is equal to the greatest

follower motion. The superposing of curves and lines often leads to confusion and error, and it is better, in general, that the time chart should consist of a series of charts or rectangles all of the same length and one directly under the other as in Fig. 17. Where there are many base curves it is desirable to separate the rectangles



FIG. 17.—TIME CHART DIAGRAM, BASE CURVES SEPARATED

by a small space to avoid any possibility of confusion due to different base curves running together. In many cases the term "time chart diagram," or "timing diagram," will be more appropriate than "time chart" in just the same way as the cam chart diagram is more appropriate than the cam chart.

20. **BASE CURVE.** Illustrated in Fig. 14. A base curve is made up of a series of smooth continuous curves, or a combination of curves and straight lines, which represent the motion of the follower, and which run in a wave-like form across the entire length of the cam chart or diagram. The base curve of the cam chart becomes the *pitch surface* of the cam.

21. **BASE LINE.** Illustrated in Fig. 15. A base line is made up of a series of inclined straight lines, or a series of inclined and horizontal lines, in consecutive order, which zigzag across the entire length of the chart. The base line when used on the *cam chart* indicates the exact motion of the follower, but when used on a *cam chart diagram* it is merely a time-saving substitute for the drawing of the base curve. The base line of the cam chart diagram represents the *pitch surface* of the cam.

22. **NAMES OF BASE CURVES OR BASE LINES IN COMMON USE,** see Figs. 18 and 19:

- | | |
|------------------------------|----------------------|
| 1. Straight line | 4. Parabola. |
| 2. Straight-line combination | 5. Elliptical curve. |
| 3. Crank curve. | |

23. PITCH LINE. Illustrated in Fig. 14. A pitch line is a horizontal line drawn on the cam chart or diagram, and it becomes the *pitch circle* of the cam. The position, or elevation, of the pitch line on the chart varies according to the base curve which is specified, and according to the data of the problem. For cams which give a

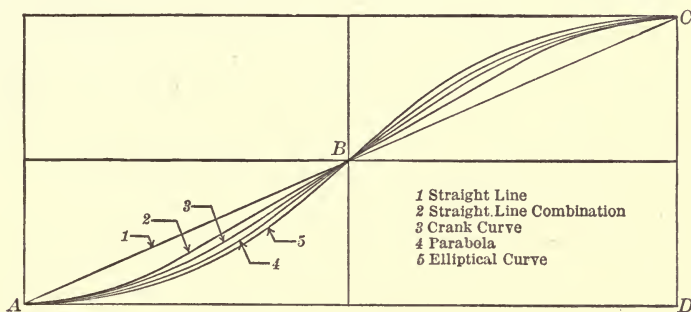

FIG. 18.—COMPARISON OF BASE CURVES IN COMMON USE SHOWING VARYING DEGREES OF MAXIMUM SLOPE WHEN DRAWN IN SAME CHART LENGTH

continuous motion to the follower during its entire stroke, or throw, the pitch line will pass through the point on the base curve which has the greatest slope, starting from the bottom of the chart. This does not apply to all possible base curves, but it does apply to all

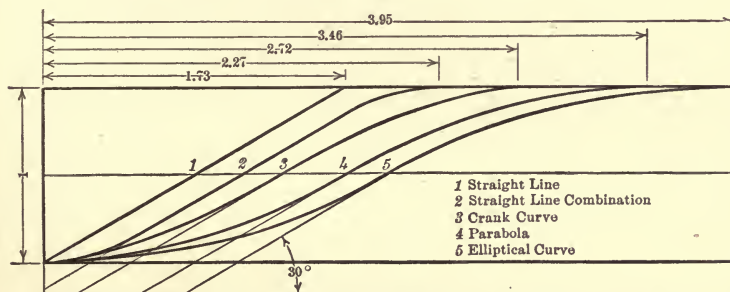

FIG. 19.—COMPARISON OF BASE CURVES IN COMMON USE SHOWING UNIFORM MAXIMUM SLOPE OF 30° WHEN DRAWN IN CHARTS OF VARYING LENGTH

those mentioned in the preceding paragraph, a minor exception being made of the crank curve which will be referred to in paragraph 34. When the cam causes the follower to move through its total stroke in two or more separate steps the position of the pitch line on the chart must be specially found as will be explained in problem 5.

24. **PITCH CIRCLE.** Illustrated in Fig. 20. A pitch circle is drawn with the center of rotation of the cam as a center, and its circumference is equal to the cam chart length. Its characteristic is that it passes through that point A , Fig. 20, of the *pitch surface* of the cam where the cam has its greatest side pressure against the follower. This applies to all cams in which the center of the follower roller moves in a straight radial line. For other motions of the follower roller, and for flat-faced followers, the pitch circle must be specially considered, as will be explained in some of the problems covering these types.

25. **PITCH SURFACE.** Illustrated in Fig. 20. The pitch surface of a cam is the theoretical boundary of the cam that is first laid down in constructing the cam. When the follower has a V-shaped edge, as at D in Fig. 7, the pitch surface coincides with the *working surface* of the cam. When the follower has roller contact, as in Fig. 20, the pitch surface passes through the axis of the roller and the working or actual surface of the cam is *parallel* to the pitch surface and a distance from it equal to the radius of the roller.

26. **WORKING SURFACE.** Illustrated in Fig. 20. The working surface of the cam is the surface with which the follower is in actual contact. It limits the working size and weight of cam. For exact compliance with a given set of cam data, the cam has only one theoretical size which is bounded by the pitch surface, but the working size may be anything within wide limits which depend on the radius of the follower roller and the necessary diameter of the cam shaft.

The working surface is found by taking a compass set to the radius of the roller and striking a series of arcs whose centers are on the pitch surface. Such a series of arcs is shown in Fig. 20 with their centers at B , A , etc. The curve which is an envelope to these arcs is the working surface.

27. **PITCH POINT OF FOLLOWER.** Illustrated in Fig. 20. The pitch point of the follower is that point fixed on the follower rod or arm which is always in theoretical contact with the pitch surface of the cam. If the follower has a sharp V-edge the pitch point is the edge itself. If the follower has a roller end, the pitch point is the axis of the roller. The pitch point is constantly changing its position from C' to D as the follower moves up and down.

✓ 28. **PRESSURE ANGLE.** Illustrated in Fig. 20. The pressure angle is the angle whose vertex is at the pitch point of the follower in its successive positions and whose sides are the direction

of motion of the pitch point and the normal to the pitch surface.

Pressure angles exist when the surface of the cam presses sidewise against the follower; they cause bending in the follower arm and side pressure in the follower guide and in the bearings. The pres-

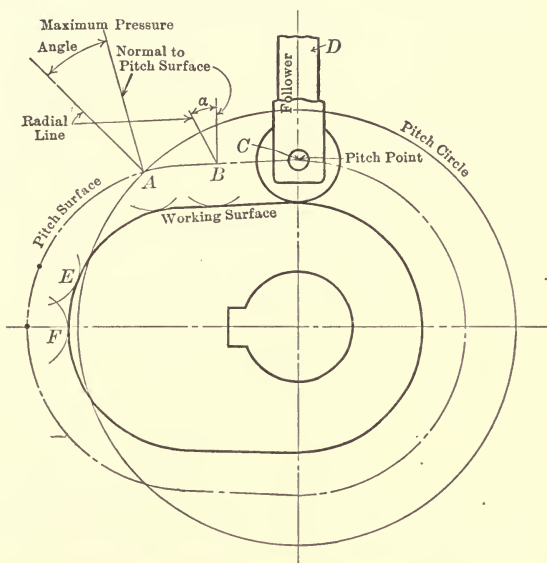

FIG. 20.—SHOWING NAMES OF SURFACES, LINES, AND POINTS OF A CAM

sure angle is constantly varying in all cams as the follower moves up and down, except where a logarithmic spiral is used. In assigning cam problems the maximum permissible pressure angle is usually given. In Fig. 20 the pressure angle is zero at C, it is equal to α at B, and is a maximum at A.

29. FORMULA FOR SIZE OF CAM FOR A GIVEN MAXIMUM PRESSURE ANGLE. The radius of the pitch circle of the cam may be found directly by the formula:

$$\begin{aligned}
 r &= h \times \frac{360}{b} \times f \times \frac{1}{2\pi} \\
 &= 57.3 \frac{hf}{b} \dots \dots \dots (1)
 \end{aligned}$$

or,

$$\begin{aligned}
 r &= h \times \frac{1}{e} \times f \times \frac{1}{2\pi} \\
 &= .159 \frac{hf}{e} \dots \dots \dots (2)
 \end{aligned}$$

in which, r = radius of pitch circle of cam.

h = distance traveled by follower.

f = factor for a given maximum pressure angle.

b = angle, in degrees, turned by cam while follower moves distance h .

e = angle, in fraction of revolution, turned by cam while follower moves distance h .

30. CAM FACTORS FOR MAXIMUM PRESSURE ANGLE. The factors, or value of f , for various maximum pressure angles for cams using the several base curves in common use are:

TABLE OF CAM FACTORS

Name of Base Curve	MAXIMUM PRESSURE ANGLE AND VALUES OF f				
	20°	30°	40°	50°	60°
Straight line.....	2.75	1.73	1.19	.84	.58
Straight-line combination*...	3.10	2.27	1.92	1.77	1.73
Crank curve.....	4.32	2.72	1.87	1.32	.91
Parabola.....	5.50	3.46	2.38	1.68	1.15
Elliptical curve†.....	6.25	3.95	2.75	1.95	1.35

These factors, for 30°, are illustrated in Fig. 19 where each of the base curves is given such a length, in terms of the height, that they will all have the same maximum slope. The values given in this table are also shown, graphically, in Fig. 21, thus enabling one to find the proper cam factor for any intermediate pressure angle between 20° and 60°.

* For case where easing off radius equals follower's motion.

† For case where ratio of horizontal to vertical axes of ellipse is 7 to 4.

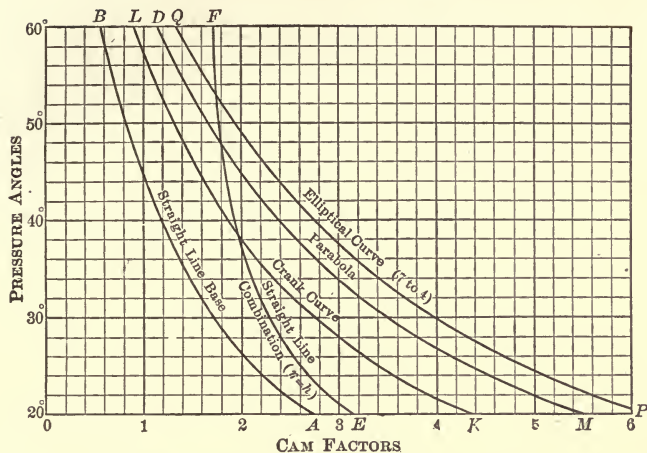

FIG. 21.—CHART SHOWING RELATION BETWEEN PRESSURE ANGLES AND CAM FACTORS FOR THE ORDINARY BASE CURVES

SECTION II.—METHOD OF CONSTRUCTION OF BASE CURVES IN COMMON USE

31. **DETAIL CONSTRUCTION OF BASE CURVES.** The method of constructing the several base curves for a rise of one unit of the follower will be explained in the succeeding paragraphs. The curves will be constructed to give a pressure angle of 30° by selecting factors from the 30° column in the table in the preceding paragraph. Should the base curve for any other pressure angle be desired the factor should be taken from the corresponding column.

32. **STRAIGHT-LINE BASE.** Fig. 22. Lay off AB equal to the follower motion, which will be taken as 1 unit in these illustrations. Multiply this by the factor 1.73 from paragraph 30, and lay off the distance AR equal to it. Complete the parallelogram and draw the diagonal. This will be the straight line base and the

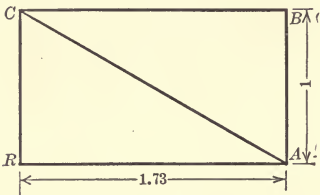

FIG. 22.—STRAIGHT BASE LINE

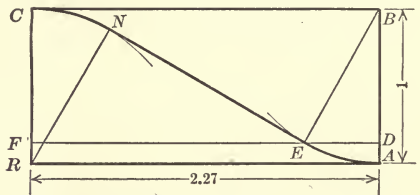

FIG. 23.—STRAIGHT-LINE COMBINATION CURVE

angle $RA C$ will be 30° . AR will be the pitch line. These base lines and curves are laid off from right to left so that they may be used in a natural manner later on in laying out the cam so that it will turn in a right-handed or clockwise direction.

The straight-line base gives abrupt starting and stopping velocities at the beginning and end of the stroke and causes actual shock in the follower arm. The velocity of the follower during the stroke is constant. The acceleration at starting and retardation at stopping is infinite and is zero during the stroke.

33. **STRAIGHT-LINE COMBINATION CURVE.** Fig. 23. Construct the rectangle with a height of 1 unit and a length of 2.27 units. With B and R as centers draw the arcs $A E$ and $C N$, and draw a straight line $E N$ tangent to them. The angle $F E N$ will then equal 30° and the line $A C$ will be a base curve made up of arcs and a

acceleration diminishes to zero at the middle of the stroke and then increases to the end. The maximum acceleration and retardation values are much less than for the straight-line combination curve, and are only a little greater than for the parabola.

35. PARABOLA. Fig. 25. Construct the rectangle. Draw the straight line RS in any direction and lay off on it sixteen equal divisions to any scale. From the sixteenth division draw a line to F , the middle point of the chart; draw other lines parallel to this through the points 9, 4, and 1, thus dividing the distance RF into four unequal parts which are to each other, in order, as 1, 3, 5, and 7. From these division points draw horizontal lines, and from H , I , and J drop vertical lines. The intersecting points, as at K ,

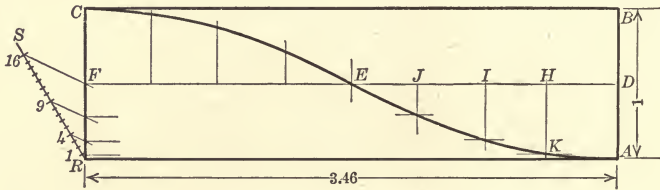

FIG. 25.—PARABOLA

will be on the desired parabola. The points H , I , and J divide the distance DE into four equal parts.

The parabola gives a uniformly increasing velocity from the beginning to the middle of the stroke; then a uniformly decreasing velocity to the end. The acceleration of the follower is constant during the first half of the stroke and the retardation is constant during the last half. The acceleration and retardation values are equal and are less than the maximum value of any of the other base curves. This means that the direct effort required to turn a positive-acting parabola cam is less than for any other type of positive cam.

36. To better understand the smooth action given by the cam using this curve, consider, 1st, DH as a time unit during which the follower rises one space unit; 2d, HI as an equal time unit during which the follower rises three space units; 3d, IJ as the time unit during which the follower rises five space units, etc. Inasmuch as the follower travels two units further in each succeeding time unit, it gains a velocity of two units in each time unit, and this is uniform acceleration.

The distance from F to C would be divided the same as from F to R and points on the part of the curve from E to C similarly

located. This curve will be identical with $E A$, but in reverse order, and will give uniform retardation. The tangent to the curve $A C$ at the point E will make an angle of 30° with $E F$, and $D F$ will be the pitch line.

Eight construction points were taken in developing the curve $A C$. Eight points will be sufficient for beginners for practice work

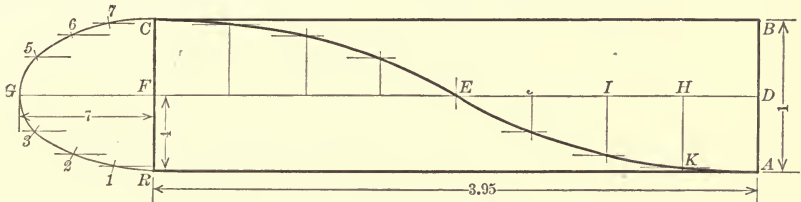

FIG. 26.—ELLIPTICAL CURVE

and later six points may be used. When using six points only nine equal divisions should be laid out on the line $R S$, the remaining construction being the same as described above, except that $D E$ should be divided into three parts instead of four. In practical work many more construction points should be used for accuracy and smooth cam action.

37. ELLIPTICAL CURVE. Fig. 26. Draw rectangle $A B C R$. Draw semi-ellipse making $F G$ equal to $\frac{7}{4} F C$. To draw the ellipse, take a strip of paper with a straight edge and mark fine lines at P , T , and S , Fig. 26a, making $P T = C F$ and $P S = G F$. Move the strip of paper so that S will always be on the line $R C$, and T on the line $F G$; P will then describe the path of the ellipse. Having the semi-ellipse, divide the part $R G$, Fig. 26, into four equal arcs as at 1, 2, 3. This is quickest done by setting the small dividers to a small space of any value and stepping off the distance from R to G . Suppose that there are 18.8 steps. Set down this number and divide it into four parts, giving 4.7, 9.4, and 14.1. Then again step off the arc from R to G with the same setting of the dividers, marking the points that are at 4.7, 9.4, and 14.1 steps. The compass setting being small, the fractional part of it can be estimated with all practical precision. Divide $D E$ into four equal parts as at H , I , J . Draw vertical lines from these points and horizontal lines from the

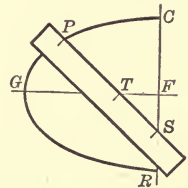

FIG. 26a.—SHOWING METHOD OF DRAWING SEMI-ELLIPSE

corresponding points at 1, 2, and 3. The intersections, as at K , will give a series of points on the elliptical base curve. The curve EC is similar to AE but in reverse order. The tangent to the curve at E makes an angle of 30° with EF , and DF is the pitch line.

The elliptical base curve gives slower starting and stopping velocities to the follower than any of the other curves, but the velocity is higher at the center of the stroke. The acceleration is variable and increases to the middle of the stroke, where its maximum value is greater than that of the crank curve but less than that of the straight-line combination curve. The retardation values decrease in reverse order to the end of the stroke.

SECTION III.—CAM PROBLEMS AND EXERCISE PROBLEMS

38. PROBLEM 1. EMPIRICAL DESIGN. Required a radial cam that will operate a V-edge follower:

- (a) Up 3 units while the cam turns 90°.
- (b) Down 2 " " " " " 60°.
- (c) Dwell " " " " " 120°.
- (d) Down 1 unit " " " " " 90°.

39. Applying the simplest process for laying out cams, it is only necessary, in starting, to assume a minimum radius CD , Fig. 27, for

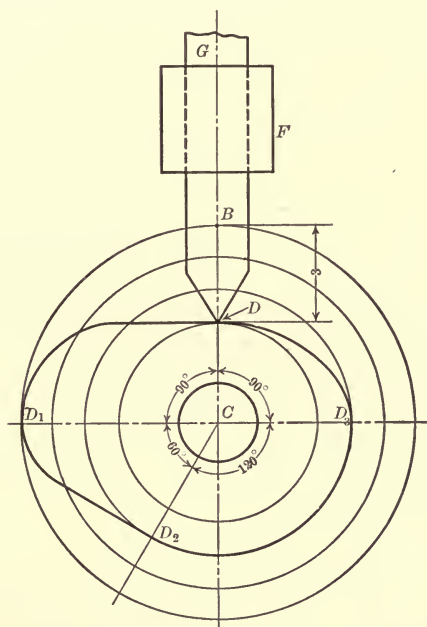

FIG. 27.—EMPIRICAL DESIGN OF CAM FOR DATA IN PROBLEM 1, V-EDGE FOLLOWER

the cam, and then lay off the given or total distance of 3 units as at DB . The assigned angle of 90° is next laid off as at DCD_1 and the point D_1 marked so as to be 3 units further out than D . Any desired curve is then drawn through the points D and D_1 and part of the cam layout is completed. The same operations are repeated for obtaining the points D_2 and D_3 and the entire cam is finished.

If the follower had roller contact instead of V-edge contact, a

minimum radius CD , Fig. 28, would be assumed as in the previous case, and D would be taken as the center of the roller. The closed curve $D, D_4, D_1 \dots$ would be obtained as before and another closed curve $E, E_1 \dots$ would be drawn parallel to it at a distance equal

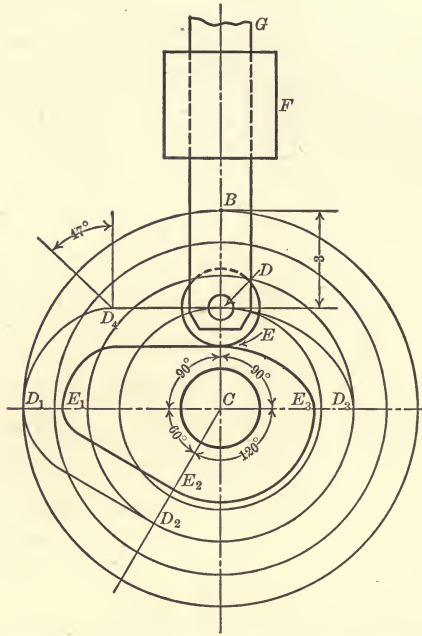

FIG. 28—EMPIRICAL DESIGN OF CAM FOR DATA IN PROBLEM 1, ROLLER FOLLOWER

to the assumed radius of the roller. The latter closed curve would be the actual outline of the cam.

The closed curve $E, E_1 \dots$ would be known as the working surface and the curve $D, D_1 \dots$ as the pitch surface of the cam. In Fig. 27 the pitch and working surfaces coincide because the follower has a V-edge.

40. Cams are sometimes designed with no more labor than that entailed in the previous preliminary problem. And it may be added that where one has had a sufficient experience good practical results may be obtained by following only this simple method.

The method of cam construction described above, however, does not enable the cam builder or designer to hold in control the velocity or acceleration of the follower rod DG as it moves up its 3 units; nor does it enable him to know the variable and maximum side pressures which exist between the follower rod and the bearing or guide

F, Fig. 27, as the rod moves up. In order that these things may be known, this preliminary problem will now be redrawn with additional specifications.

41. **PROBLEM 2. TECHNICAL DESIGN.** Required a radial cam that will operate a roller follower:

- (a) Up 3 units while the cam turns 90°.
- (b) Down 2 " " " " " 60°.
- (c) Dwell " " " " " 120°.
- (d) Down 1 unit " " " " " 90°.

(e) The follower, in all its motions, shall start with uniform acceleration and stop with uniform retardation.

(f) The angle of side pressure of the follower rod against the guide shall not exceed 40°.

Items (a), (b), (c), and (d) are the same as in Problem 1.

42. Inasmuch as this problem is given at this place simply to show that velocity and acceleration and side pressure can always be controlled with very little additional labor beyond that necessary for the simple layout shown in Fig. 28, the full explanations of the formula and figures used will not be given here. They will be taken up in their proper order in subsequent paragraphs. For this problem the only necessary computation is:

$$r = 57.3 \frac{hf}{b} = 57.3 \frac{3 \times 2.38}{90} = 4.55 = \text{Radius of pitch circle} =$$

CH, Fig. 29.

The reference letters, *h*, *f*, and *b* are defined in paragraph 29. Lay off *CH* in Fig. 29, and then lay off the follower motion of 3 units equally distributed on each side of *H*, as at *HB* and *HD*. Divide *DH* into nine equal parts and take the first, fourth, and ninth parts; do likewise with *BH*. Divide the 90° angle *BCD*₁ into six equal parts by radial lines as shown, and swing each of the six division points between *D* and *B* around until they meet successively the six radial lines.

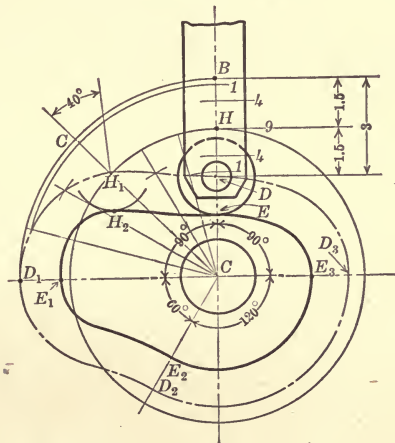

FIG. 29.—TECHNICAL DESIGN OF CAM FOR DATA IN PROBLEM 2, DRAWN TO SAME SCALE AS FIG. 28

A curve through the intersecting points will be the pitch surface of the cam, as shown by the dash-and-dot curve $D H_1 D_1 \dots$

The working surface will be $E E_1 \dots$ which is found as described in paragraph 26.

The pitch surface $D_1 D_2$ is obtained in the same way as $D D_1$ was found. The curve $D_2 D_3$ is an arc of a circle, and the curve $D_3 D$ is found in the same manner as $D D_1$.

43. ADVANTAGES OF THE TECHNICAL DESIGN. With the cam constructed as above the follower will start to move with the same characteristic motion as has a falling body starting from rest, and the follower will be stopped with the same gentle motion in reverse order. It

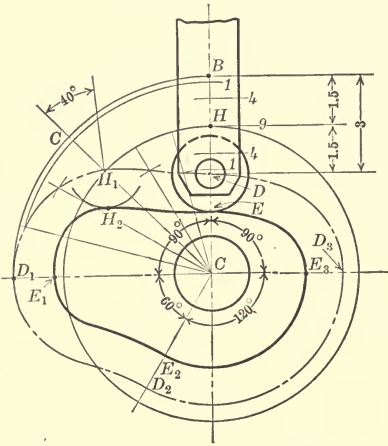

FIG. 29.—(Duplicate) TECHNICAL DESIGN OF CAM FOR DATA IN PROBLEM 2, DRAWN TO SAME SCALE AS FIG. 28

will be definitely known also that the greatest side pressure of the cam against the follower is at an angle of 40° as specified, and that this pressure will occur when H_1 of the pitch surface of the cam is at H , or when the roller is in contact with the working surface at H_2 . Where the cam form is assumed as in Fig. 28, nothing is known positively of the starting and stopping velocities of the follower. Further, as may be found by trial, the maximum angle of pressure of the cam against the rod runs up to 47° in Fig. 28, as shown at D_4 . The minimum radius of the cam in Fig. 28 was taken equal to that in Fig. 29 for comparison.

44. The two previous problems have been given as brief exercises without going into all the detail necessary to a full understanding, in order to give an idea of the method of producing cams on a scientific basis. In the problems which will follow, the several steps in building cams of various types will be explained. In many of the problems the same data will be used so that comparisons of different forms of cams which produce the same results may be made.

45. PROBLEM 3. SINGLE-STEP RADIAL CAM, PRESSURE ANGLE EQUAL ON BOTH STROKES. Required a single-step radial cam in which the center of the follower roller moves in a radial line. The maximum pressure angle to be 30° , and the follower to move:

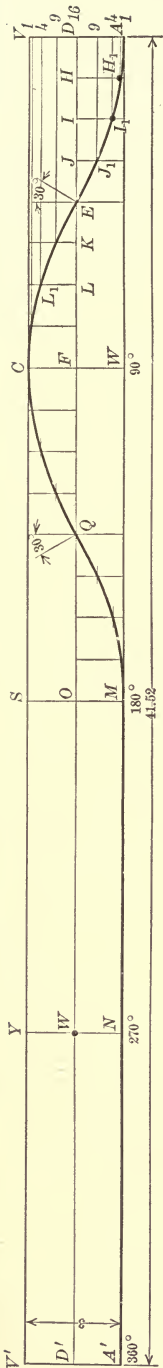

FIG. 30.—PROBLEM 3, CAM CHART

(a) Up 3 units in 90° with uniform acceleration and retardation.

(b) Down 3 units in 90° with uniform acceleration and retardation.

(c) At rest for 180° with uniform acceleration and retardation.

46. The first step in the solution is to determine the total length of the cam chart for a parabola chart curve and for a 30° maximum pressure angle. From the table, paragraph 30, the factor for this case is found to be 3.46. Since the travel of the follower is 3 units in $\frac{1}{4}$ revolution, the total length of chart will be $3 \times 3.46 \times 4 = 41.52$, which, therefore, is the length of the chart $A A'$ in Fig. 30. This length represents the 360° of the cam. Lay off $A W$ equal to 90° , according to item (a) in the data. Construct the parabolic curve $A E C$. Completing the entire chart, the base curve is found to be $A C M N A'$. The next step is to find the radius of the pitch circle. The circumference of this circle is equal to the length of the pitch line $D D'$. Its radius is, therefore, equal to $\frac{41.52}{2\pi} = 6.61$, and this value is laid off at $O D$, Fig. 31, and the pitch circle $D F Q W$ drawn. The quadrant $D F$ is divided into the same number of parts as $D F$ in Fig. 30. The vertical construction lines $H H_1, I I_1, J J_1 \dots$ in Fig. 30 now become the radial lines correspondingly lettered in Fig. 31, and the pitch surface is drawn through the points $A H_1 I_1 J_1 \dots$. The positions of maximum pressure are shown at E and Q ; at all other points it will be less. The working surface $B G R P$ is found by assuming a radius $A B$ for the roller, and by striking a series of arcs as shown at $H_2, I_2, J_2 \dots$ with the points $H_1, I_1, J_1 \dots$ as centers, and then drawing the working curve tangent to these arcs. With the same specifications for the up and down motions of the follower, as given by items (a) and (b) in the data, this type of cam will be symmetrical about the line $Y C$.

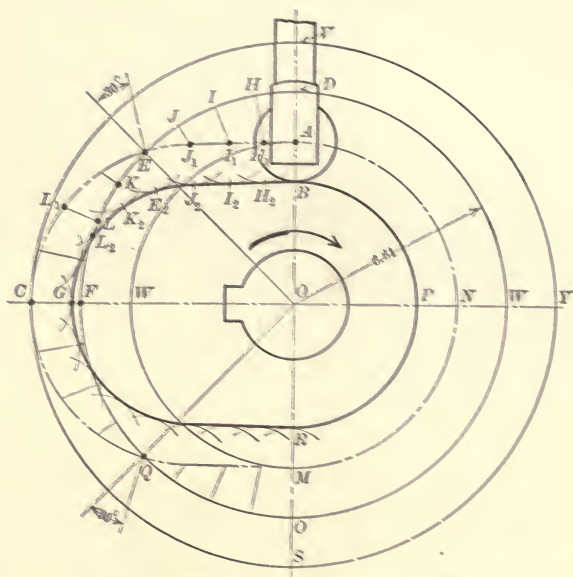

FIG. 31.—PROBLEM 3, CAM LAID OUT FROM CAM CHART

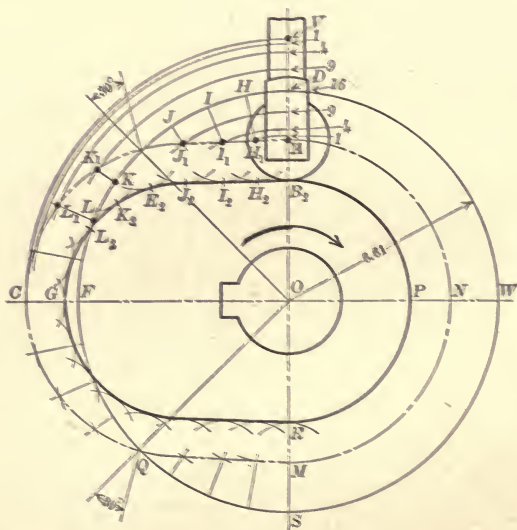

FIG. 32.—PROBLEM 3, CAM LAID OUT INDEPENDENTLY OF CAM CHART

47. OMISSION OF CAM CHART. When the relation between pressure angle, chart base and pitch lines, and cam pitch and surface lines is understood and fixed in mind, the actual drawing of the chart for the graphical construction of simple cams and particularly of single-step cams may be omitted with full confidence when the elementary base curves are used. For example, the problem in the previous paragraph is shown completely worked out in Fig. 32 without any reference whatever to the chart of Fig. 30. The radius OD of the pitch circle, Fig. 32, is obtained directly from the formula,

$r = 57.3 \frac{hf}{b}$ given in paragraph 29. Substituting the data as given

in the previous paragraph, $r = 57.3 \frac{3 \times 3.46}{90} = 6.61$ and is laid off

at DO . The assigned motion of the follower is laid off symmetrically on both sides of the pitch point D , as at AV , and the distances AD and VD are divided into the desired number of unequal parts, as at 1, 4, 9, 16. The quadrant DF is divided into the same number of equal parts as at $H, I, J \dots$ and indefinite radial construction lines drawn through the points. Circular construction arcs are next drawn through the points 1, 4, 9 \dots until they intersect the radial lines, thus obtaining points $H_1, I_1, J_1 \dots$ on the cam pitch surface. In general, a neater construction is obtained by omitting the full length of the construction arcs, as from V to $C \dots$ and simply drawing short portions of the arc at the intersecting radial lines as shown in the lower left-hand quadrant between C and M .

48. EXERCISE PROBLEM 3a. Required a single-step radial cam in which the center of the follower roller moves in a radial line. The maximum pressure angle to be 40° , and the follower to move:

- (a) Out 6 units in 135° on the crank curve.
- (b) In 6 " " 135° " " " " " "
- (c) At rest for 90° .

49. PROBLEM 4. SINGLE-STEP RADIAL CAM, PRESSURE ANGLES UNEQUAL ON THE TWO STROKES. Required a single-step radial cam in which the center of the follower moves in a radial line. The maximum pressure angle not to exceed 30° on the outstroke nor 50° on the return stroke, and the follower to move:

- (a) Out 2 units in $\frac{5}{16}$ revolution on the crank curve.
- (b) In 2 " " $\frac{3}{16}$ " " " " " "
- (c) At rest for $\frac{1}{2}$ revolution.

50. The diameter of pitch circle of the cam that will be necessary to fulfil the requirements on the outstroke will be:

$$d_a = \frac{2 \times 2.72 \times 16}{3.14 \times 5} = 5.54 \text{ units, or from formula paragraph 29.}$$

$$r = .159 \frac{2 \times 2.72 \times 16}{5} = 2.77,$$

and the diameter of pitch circle required for the instroke will be

$$d_b = \frac{2 \times 1.32 \times 16}{3.14 \times 3} = 4.48 \text{ units.}$$

Inasmuch as there can be only one pitch circle for a cam, the largest one resulting from the several specifications must be used. In this problem then the diameter SD of the pitch circle in Fig. 33

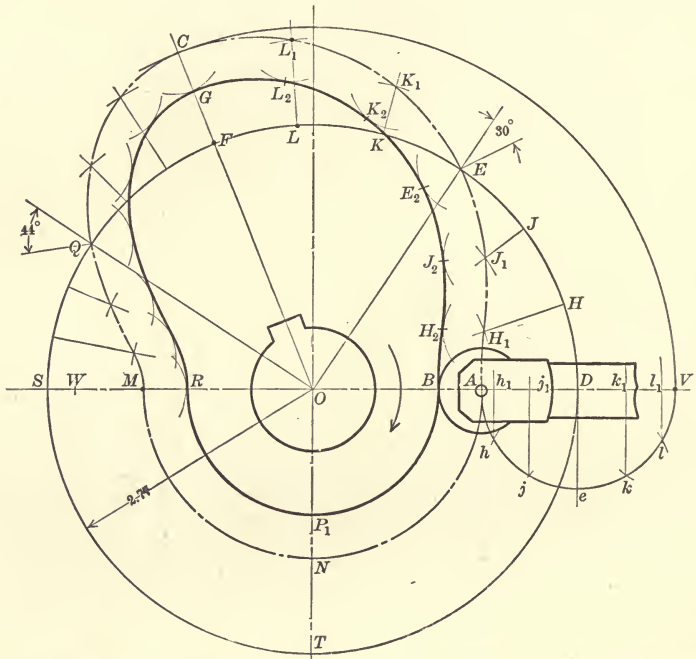

FIG. 33.—PROBLEM 4, MAXIMUM PRESSURE ANGLE DIFFERENT ON THE TWO STROKES

equals 5.54 units. The follower's motion of two units is laid out at AV and the pitch surface $AECMN$ constructed. The working surface of the cam BKG , etc., is then drawn. Since a larger diameter of pitch circle had to be used for the return stroke than the require-

ments called for, it follows that the pressure angle will not reach 50° on that stroke, and it may be of some interest to determine what the maximum pressure angle on the return stroke will be. Substituting the diameter used, 5.54, in the formula $d = \frac{hf}{\pi e}$ and solving for f , f is found to be equal to 1.63. From the chart in Fig. 21 it is shown that a factor of 1.63 for the crank curve corresponds to a maximum pressure angle of nearly 44° , and this angle may be drawn in its proper position at Q in Fig. 33.

51. EXERCISE PROBLEM 4a. Required a single-step radial cam in which the center of the follower roller moves in a radial line. The maximum pressure not to exceed 30° on the up stroke nor 40° on the down stroke, and the follower to move:

- (a) Up 3 units in 135° on the parabola curve.
- (b) At rest for 45° .
- (c) Down 3 units in 90° on the parabola curve.
- (d) At rest for 90° .

52. PRESSURE ANGLE INCREASES AS PITCH SIZE OF CAM DECREASES. This is illustrated in Fig. 34, where the large pitch cam represented by $D, D_2 \dots$ gives exactly the same motion to a follower as the small pitch cam $d, d_2 \dots$. It will be noted that the pressure angle for the large cam, at the start, is $H D G$, while for the small cam it is increased to $h d g$. Likewise the maximum pressure angle for the large cam, when the follower is near the end of its stroke, is b_1 , while for the small cam the maximum pressure angle is b , which is larger than b_1 . From these observations it may be said, in general, that the larger the *pitch* surface of the cam the smaller will be the pressure angle. The size of the roller has no effect whatever on the pressure angle. Two cams of the same *pitch* size may be of totally different *actual* sizes for the same work, one cam having a large roller and the other a small roller. Therefore it is important to remember that, in general, the pressure angle may be regulated by changing the size of the *pitch* surface only and not the working surface.

53. CHANGE OF PRESSURE ANGLE IN PASSING FROM CHART TO CAM. The circumference of the pitch circle of the cam, it will be recalled, is equal to the length of the pitch line on the chart. It will also be remembered that the pitch line may be at various heights on the chart, paragraph 23. It is now important to consider:

1st. That the pressure angle at the pitch circle on the cam must be the same as the pressure angle at the pitch line on the chart.

2d. That the pressure angle at any point on the pitch surface of the cam outside of the pitch circle will be less than the pressure angle of the corresponding point on the base curve of the cam chart.

3d. That the pressure angle at any point on the pitch surface

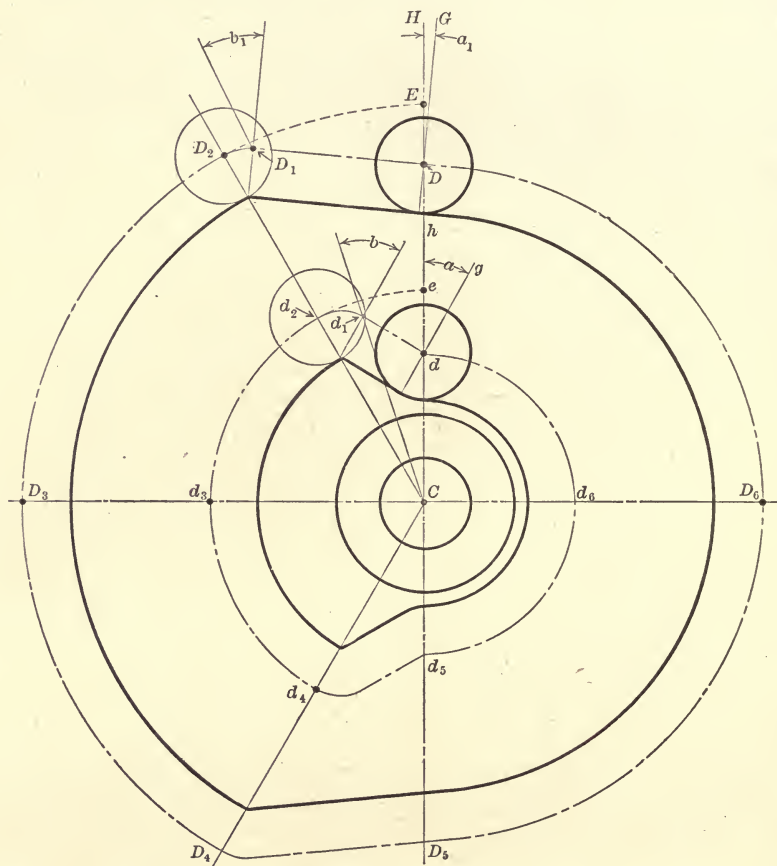

FIG. 34.—SHOWING RELATION BETWEEN PRESSURE ANGLE AND SIZE OF PITCH CAM

of the cam inside of the pitch circle will be greater than the pressure angle of the corresponding point on the base curve of the cam chart.

These statements, which are theoretically true for nearly all cases, and practically so for all other cases where the usual base curves are employed, are demonstrated in the following paragraph.

54. CAM CONSIDERED AS A BENT CHART. Consider that the cam itself is the cam chart bent in its own plane so that the pitch line

becomes the pitch circle. Then the line DD' , Fig. 30, becomes the circle $DFOW$, Fig. 31; the line VV' is stretched to become the circle $VC SY$, and the straight line AMA' is compressed to become the circle AMA . This means, in a general way, that the rectangle $DVV'D'$, Fig. 30, is so distorted that if an original diagonal had been drawn from D to V' it would have an increased length and a decreasing slant after the bending had taken place. With a decreasing slant of the pitch surface the pressure angle will decrease. Likewise, a diagonal drawn from D' to A in the original rectangular chart would be decreased in length and would have an increasing slant, and the pressure angle would be increasing toward A . This is illustrated in detail in Figs. 35 and 36.

55. BASE LINE ANGLES, BEFORE AND AFTER BENDING. The pressure angle of 30° at E in Fig. 35 is reduced to 23° in Fig. 36, and the

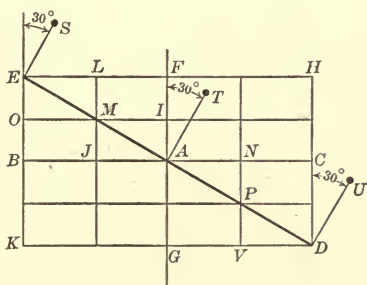

FIG. 35.—SECTION OF CAM CHART BEFORE BENDING

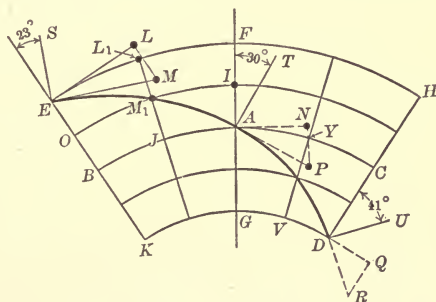

FIG. 36.—SECTION OF CAM CHART AFTER BENDING, BC CONSTANT IN BOTH FIGURES

30° at D are increased to 41° . Fig. 35 represents a cam chart with a straight base line DE , and Fig. 36 is a corresponding cam sector with DE as the pitch surface. If BC , Fig. 35, is taken as the pitch line, BC , Fig. 36, will be part of the pitch circle. The uniform pressure angle of 30° from A to E , Fig. 35, will grow smaller beyond A in Fig. 36 for the reason that the radial components of the tangential triangles remain constant, as illustrated at LM , while the tangential components grow longer as illustrated at AN and EL , which are respectively equal to the arcs AY and EL_1 . Consequently, the angles grow smaller from the angle NAP to LEM . Similarly it may be shown that they grow larger from NAP to QDR .

56. LIMITING SIZE OF FOLLOWER ROLLER. The radius of the follower roller may be equal to, but in general should be less than

the shortest radius of curvature of the pitch surface, when measured on the working-surface side. If the radius of the roller is not so taken, the follower, when put in service, will not have the motion for which it was designed.

57. CASE 1. RADIUS OF ROLLER EQUAL TO RADIUS OF CURVATURE OF PITCH CAM. In Fig. 37, $A B E F A$ is the pitch surface of a cam.

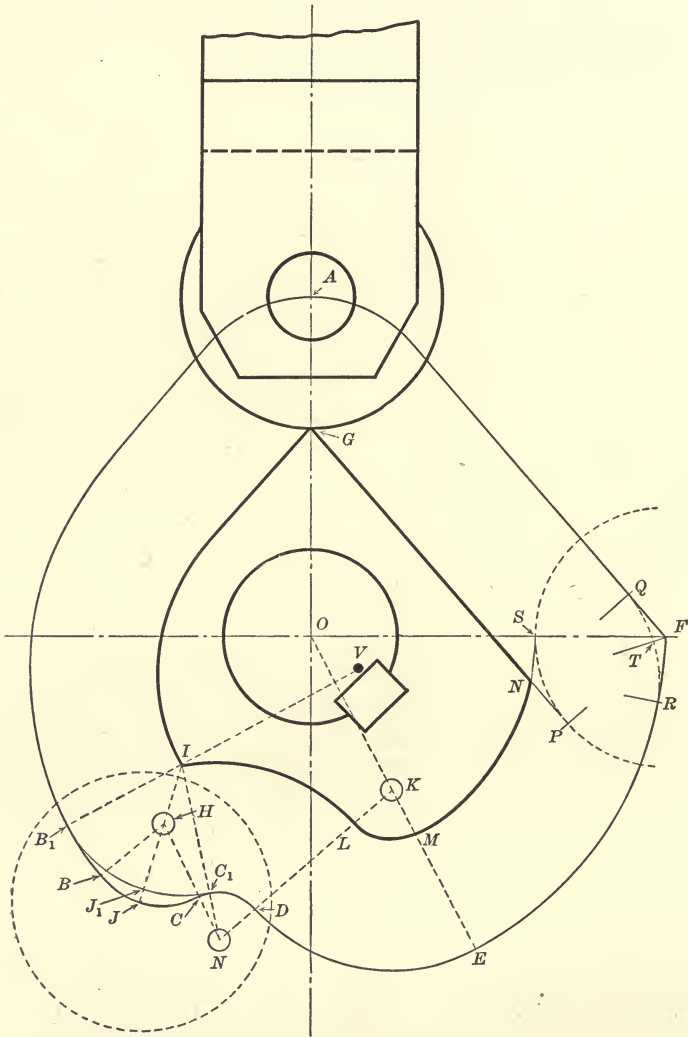

FIG. 37.—LIMITING SIZE OF FOLLOWER ROLLER

GA is the radius of curvature at A and AG is the radius of the roller. In this case both radii are equal and the working surface has a sharp edge at G .

58. CASE II. RADIUS OF ROLLER GREATER THAN RADIUS OF CURVATURE OF PITCH CAM. From B to C , Fig. 37, the radius of curvature of the pitch surface is HB , which is less than the roller radius. In this case the working surface will be undercut at I in generating the cam, and if the cam is built the center of the roller will mark the path $B_1 J_1 C_1$ instead of BJC , and the follower will fail to move the desired distance by the amount $J J_1$.

59. SPECIAL APPLICATION OF CASE II. EFFECT OF AN ANGLE IN THE PITCH SURFACE OUTLINE. This is illustrated at RFQ in Fig. 37, and is a special application of Case II, in which the radius of curvature of the cam's pitch surface is reduced to zero. Undercutting is here illustrated by considering that a cutter, represented by the dash circular arc, is moving with its center on the pitch surface arc EF . It then cuts the working surface MS . As the center of the cutter is moved from F toward A , the part NS of the working surface which was previously formed is now cut away, leaving the sharp edge N on which the follower roller will turn when the cam is placed in operation. The center of the follower roller will then move in the path RTQ instead of RFQ , and the follower will fall short of the desired motion by the amount TF .

60. CASE III. RADIUS OF ROLLER LESS THAN RADIUS OF CURVATURE OF PITCH CAM. From D to E , Fig. 37, the radius of curvature of the pitch surface is KD , which is greater than the roller radius. In this case, which is the practical one, although close to the limit, a smooth curved working surface is provided for the roller from L to M .

61. RADIUS OF ROLLER NOT AFFECTED BY RADIUS OF CURVATURE ON NON-WORKING SIDE. From C_1 to D , Fig. 37, the radius of curvature of the pitch surface is less than the radius of the roller, but this short radius is not on the working side of the pitch surface, and therefore the roller will roll on the surface IL while its center travels on the pitch curve $C_1 D$.

62. ROLLERS FOR POSITIVE-DRIVE CAMS. When the largest roller for a positive or double-acting cam is being determined the radius of curvature on both sides the pitch-surface curve must be considered and the smallest radius used. For example, in Fig. 37, if $AJET A$ were the pitch surface for a double-acting cam, NC would be the maximum roller radius, whereas HJ would be

the maximum radius if it were for an external single-acting cam.

63. RADIUS OF CURVATURE OF NON-CIRCULAR ARCS. In illustrating the above cases the pitch surface was assumed as being made up of straight lines and arcs of circles in order to show more effectively and more simply the limits of action in each instance. Where the pitch surface contains curves of constantly varying curvature, and they generally do in practice, the shortest radius of curvature of the pitch surface may be found with all necessary accuracy by trial with the compass, using finally that radius whose circular arc agrees for a small distance with the irregularly curved arc. For example, in Fig. 38, let $G H D J B$ be a portion of a pitch surface

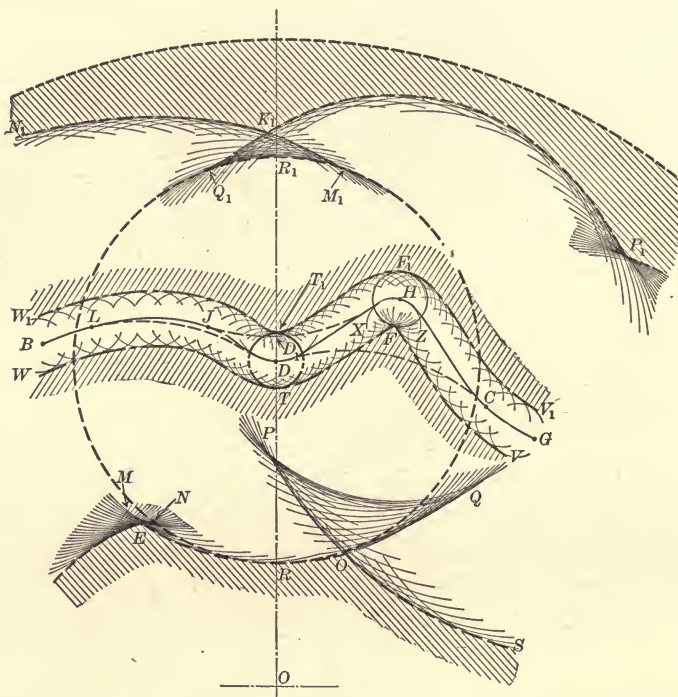

FIG. 38.—LIMITING SIZE OF FOLLOWER ROLLER WORKING ON NON-CIRCULAR CAM CURVES

made up of non-circular arcs. The shortest radius of curvature on both sides is found, by trial, to be $F H$. The center F is marked and the osculatory arc $X H Z$ drawn in. Then $H F$ is the largest possible radius of roller for a double-acting cam, and with this roller the working surfaces will be $V F T W$ and $V_1 F_1 T_1 W_1$.

If a larger roller is used, with a radius DR , for example, the working surfaces of the groove will be SOE and $P_1K_1N_1$, and the new pitch surface, after cutting the cam, will be $GCDLB$, if the roller is kept always in contact with the inner surface of the groove. If it is kept always in contact with the outer surface of the groove, the original pitch surface will be changed to $GCHD_1JB$. In either case the original desired follower motion is not obtained if the roller is too large, and if a positive-drive cam is run with the larger roller the follower's motion will be indeterminate, the center of the roller having any possible position between CDL and $CHJL$.

64. PROBLEM 5. DOUBLE-STEP RADIAL CAM. Required a double-step radial cam in which the center of the follower roller moves in a radial line. The maximum pressure angle to be 30° , and the follower to move:

- (a) Up 4 units in $\frac{1}{8}$ revolution on the crank curve.
- (b) At rest for $\frac{1}{4}$ revolution.
- (c) Up 4 units in $\frac{1}{8}$ revolution on the parabola curve.
- (d) Down 2 units in $\frac{1}{8}$ revolution on the elliptical curve.
- (e) At rest for $\frac{1}{8}$ revolution.
- (f) Down 6 units in $\frac{1}{4}$ revolution on the parabola curve.

65. In Problem 3 there are only two motion assignments, (a) and (b), in the data, and they were the same except for direction. Consequently only one computation was necessary. When two or more dissimilar assignments are made in the data, as in the present problem, it is advisable to make a computation for the length of the chart diagram for each motion specification, as follows:

- (a) $4 \times 2.72 \times 8 = 87.04$, which is the length of chart and of the pitch circle circumference = 13.86 pitch circle radius.
- (c) $4 \times 3.46 \times 8 = 110.72$, which is the length of chart and pitch circle circumference = 17.62 pitch circle radius.
- (d) $2 \times 3.95 \times 8 = 63.20$, which is the length of chart and pitch circle circumference = 10.06 pitch circle radius.
- (f) $6 \times 3.46 \times 4 = 83.04$, which is the length of chart and pitch circle circumference = 13.22 pitch circle radius.

Inasmuch as there is a different length of chart and a different pitch line for each item in the data one can not tell which pitch line to take without some preliminary computation. For this purpose

a chart diagram is well adapted, as follows: Construct a rectangle, Fig. 39, with a height $A T$ equal to the total motion of the follower in one direction, 8 units in this case. Make the length $A A'$ of rectangle any convenient value entirely independent of any of the values computed above and label this according to the longest chart length as computed above. Lay off straight lines to represent the component parts of the base curve as assigned in the data and label them as shown at $A C$, $C B$, $B H$, etc. Draw the several pitch lines as at $F D$, $J I$, etc.

66. For general procedure, consider the pitch line which passes through the point calling for the longest chart length. This will be the pitch line $J I$ passing through G , Fig. 39, which calls for a chart length of 110.72 and a pitch radius of 17.62. If G is to be at

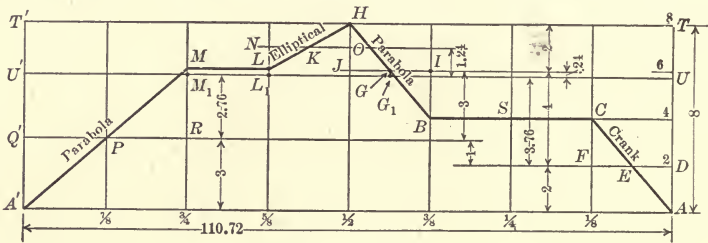

FIG. 39.—PROBLEM 5, CAM CHART DIAGRAM FOR DOUBLE-STEP CAM

a radius of 17.62 in the cam, E will be at a radius of $17.62 - 4 = 13.62$. But from computation (a) it is seen the E must be at a radius of 13.86. Therefore, if the radius of cam pitch circle is retained at 17.62, the trial pitch line, $J I$, on the chart diagram will have to be lowered, $13.86 - 13.62 = .24$, giving the new pitch line $U U'$. If the line $U U'$ now becomes the pitch circle the point E will be at $17.62 - 3.76 = 13.86$, just as called for in computation (a), and the pressure angle will be 30° at the point E on the cam.

The other critical points at P and K must also be tested with respect to the proposed pitch line, $U U'$. With this pitch line the point P will be 2.76 inside of the pitch circle, or at a radius of $17.62 - 2.76 = 14.86$. This is safe, as the computed radius for P was only 13.22 according to item (f). The point K is also safe, for it will be at a radius of $17.62 + 1.24 = 17.86$, whereas a radius of only 10.06 is required.

67. The cam may now be drawn by constructing the true cam chart as in Fig. 40, which is lettered the same as Fig. 39, and plotting the cam from it as in Fig. 41. The pitch line $U U'$ of Fig. 40 be-

(c) At rest for 60° .

(d) In 3 units in 120° on the elliptical curve.

70. PROBLEM 6. CAM WITH OFFSET ROLLER FOLLOWER. Required a single-step radial periphery cam in which the center of the follower roller moves forth and back in a straight line which does not pass through the center of rotation of the cam. The maximum pressure angle when the follower is at the bottom of its stroke is to be 30° , and the follower is to move:

(a) Up 3 units in 90° on the parabola curve.

(b) Down 3 " " 90° " " " "

(c) At rest for 180° .

71. Problems of this nature are totally different, both in pressure-angle action and in methods of construction, from the preceding ones. As may be noted in the data, it is required that the pressure angle, *when the follower is at rest at the bottom of its stroke*, shall be 30° . It will appear presently that the pressure angle, when the follower is in motion, may be zero or even negative on one of the strokes in this form of cam. It will also be shown that the maximum pressure angle during the follower motion cannot be assigned in advance and obtained in any practical manner. From the above it follows that the offset radial cam has a peculiar advantage in keeping considerable side pressure off the follower guides during the time that the follower is moving in one direction, although at the bottom of the stroke the pressure angle may have any desired value, and during the period of motion in the opposite direction the pressure angle will reach a maximum value much larger than the assigned angle at the bottom of the stroke.

72. The method of construction for the offset roller cam is illustrated in Fig. 43. The diameter of the pitch circle, $UF'ST$; is computed as before by the formula, $d = 114.6 \frac{hf}{b}$, and found to be 6.61

units. An angle equal to the assigned pressure angle is then laid off at UOU' , UO being parallel to the direction of motion of the follower. Draw a line, DW , parallel to UO and so located that it has an intercept DA between the pitch circle and the inclined line equal to one-half the travel of the follower. This may be done by trial, or graphically, as shown by the dotted-line construction which is drawn at $Y'XA'$ instead of at Y to avoid complication of construction lines. The angle UOY' equals the angle UOY . $Y'X$, parallel to UO , is drawn equal to one-half the stroke. An arc XA' ,

parallel to the arc $Y' U$, is drawn through X by using $U O$ as a radius and Z as a center, where $O Z$ equals $Y' X$. A circular arc through A' with O as a center will intersect $O U'$ in the desired point A . The point A will then be the lowest point of the stroke, D will be the center of the stroke, and $W O$ the radius of the construction circle.

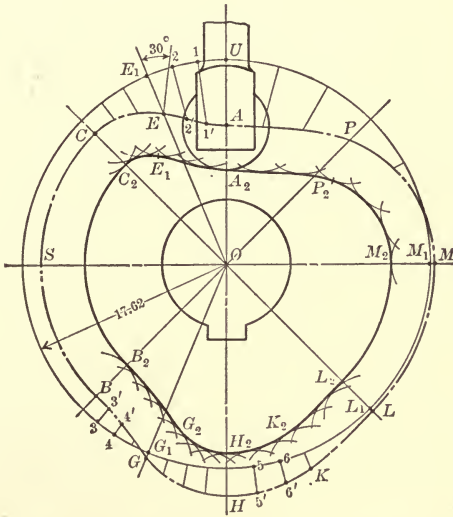

FIG. 41.—PROBLEM 5, DOUBLE-STEP CAM CONSTRUCTED FROM CAM CHART

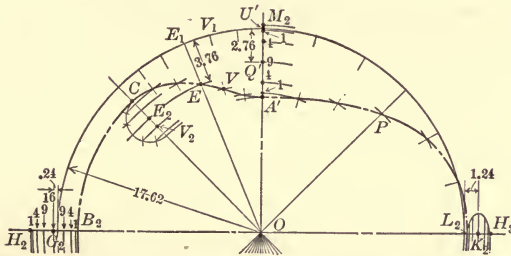

FIG. 42.—PROBLEM 5, DOUBLE-STEP CAM CONSTRUCTED WITHOUT USE OF CAM CHART

The distance $A V$ is equal to the assigned 3 units of motion, and the divisions $1, 4, 9 \dots$ are made according to the requirements of the parabola curve. The assigned 90° is laid off on the construction circle at $W F$ and divided into a number of equal arcs at $H, I, J \dots$ corresponding to the number of divisions at $A V$, eight being used in the present example. Tangents to the construction circle,

such as $H H_1, I I_1, J J_1 \dots$ are then drawn at $H, I, J \dots$ and the distances $W_1, W_4, W_9 \dots$ laid off on these tangents, thus giving the points $H_1, I_1, J_1 \dots$ on the pitch surface of the cam. Or these latter points may be obtained by swinging arcs through $1, 4, 9 \dots$ about O as a center, until they meet the respective tangents at $H_1, I_1, J_1 \dots$.

73. An examination of the pressure angles for a cam with an offset follower shows that during the up stroke the pressure angles are very small, being, in fact, negative from J_1 to K_1 , Fig. 43, and, when measured, the average pressure angle for the working or up stroke is between 6 and 7 degrees in this problem; although on the down or return stroke it reaches an average of between 37° and 38° and a maximum of 46° near Q' . In this class of problem the computation for diameter of pitch circle serves merely as a guide in determining a size that will give a small cam and a small average pressure angle on the working stroke. If the diameter of the pitch circle is arbitrarily taken either larger or smaller than the value, as above computed, or if other base curves are used, the negative pressure angles at J_1, E_1 , and K_1 may disappear entirely; which would be an advantage where it is desired to have pressure on the follower guides on one side only.

74. It has doubtless been observed that there is a decided lack of symmetry in this form of cam, even though the data are similar for both strokes of the follower. This is illustrated in Fig. 43, where the portion $A C$ of the pitch surface for the outstroke is quite different from the portion $C M$. It is also characteristic of this form of cam that the pitch and working curves each embrace either a smaller or a larger angle than the assigned angle for a given stroke of the follower, as shown by the angle $A O C$ being less, and the angle $C O M$ being greater, than the assigned 90° . This, of course, is due to the fact that when C has traveled 90° to V the line $O C$ will have passed the original zero line $O A$ of the pitch curve and will be in the position $O V$. Therefore, the cam angle for one stroke of the follower will be less than the assigned angle by the amount of the angle included by $V O A$; for the other stroke it will be greater than the assigned angle by the same amount.

75. EXERCISE PROBLEM 6a. Required a single-step radial periphery cam in which the center of the follower roller moves forth and back in a straight line which does not pass through the center of rotation of the cam. The maximum pressure angle when the follower is at the bottom of its stroke is to be 40° , and the follower is to move:

- (a) Out 6 units in 135° on the crank curve.
 (b) In 6 " " 135° " " " "
 (c) Rest for 90° .

In this problem, only the initial pressure angle at the bottom of the stroke need be shown; the pressure angles at other positions, such as are shown in Fig. 43 at H_1, I_1 , may be omitted.

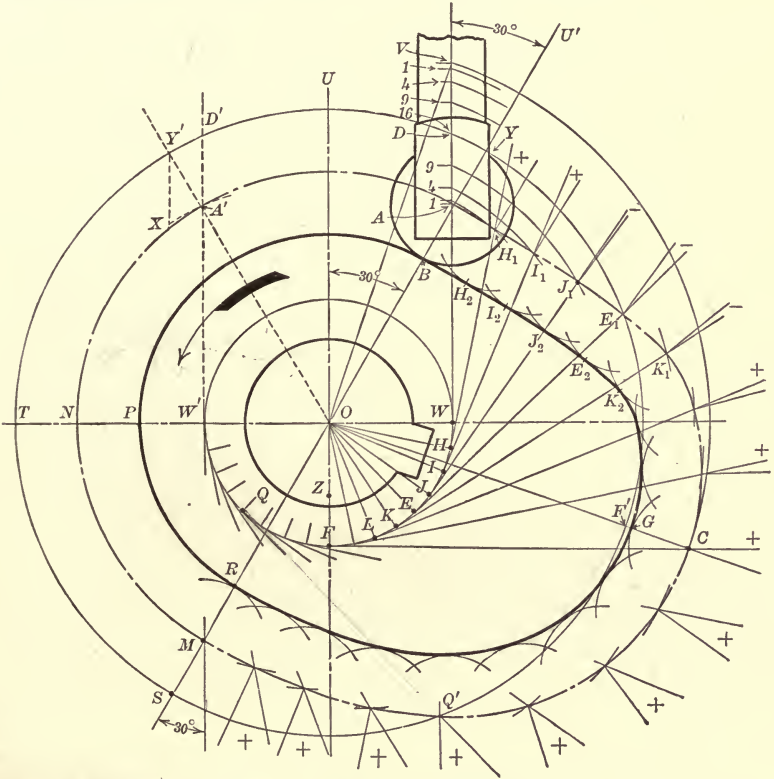

FIG. 43.—PROBLEM 6, CAM WITH OFFSET ROLLER FOLLOWER

76. PROBLEM 7. CAM WITH FLAT SURFACE FOLLOWER,—MUSHROOM CAM. Required a radial periphery cam to operate an offset follower which has a flat surface instead of a roller. The follower to move:

- (a) Up 3 units in 90° on the parabola base.
 (b) Down 3 " " 90° " " " "
 (c) At rest for 180° .

77. This type of cam is known also as the mushroom cam. Flat

surface followers may be offset as shown in the side and top views in Fig. 44, where the center line $N'' Y''$ of the follower spindle is set the distance $P'' O''$ in front of the center of the cam plate. In this case there will be a part sliding and part rolling of the cam on the follower and the follower will turn about its own axis, $N'' Y''$, as it

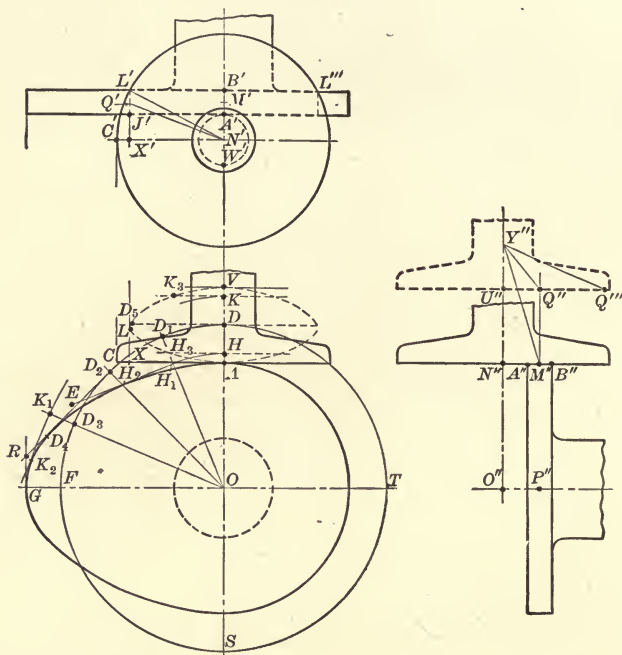

FIG. 44.—PROBLEM 7, CAM WITH FLAT SURFACE FOLLOWER—MUSHROOM CAM

is being raised and lowered. When the follower is not offset, *i.e.*, when the center line $O'' N''$ is placed in line with $M'' P''$, the action will be all sliding and there will be no turning of the follower spindle on its axis. In this case there will be localized wear on the follower, while in the former case the wear will be more widely distributed over the follower surface. In both cases the construction is the same and is explained in the following paragraph.

78. In cam followers having flat surfaces perpendicular to the line of action, the line of pressure is $M'' Q''$ and is parallel to the line of action of the follower, instead of being inclined to it as in the case of cams having roller followers. Because of this characteristic action the ordinary pressure-angle factors do not apply in

cams of this class in computing or obtaining the diameter of the pitch circle $DFST$, and this circle may be assumed. In some cases a fair guide for the size of this circle may be obtained by using

the regular formula, $d = 114.6 \frac{hf}{b}$, for diameter of pitch circle, as-

suming the 30° pressure angle factor. Solving, d is found to equal 6.61, and is laid off at OD . The assigned three units of motion are then laid off, one-half on each side of D , as at A and V . The assigned 90° are next laid off at AOF and divided into the desired number of construction parts, four being used in this case, as at OD_1, OD_2, \dots . The distance AV is also divided into four parts, AH and VK being each equal to 1 unit and HD and KD equal to 3 units. Only four divisions are taken in this case to avoid confusion of lines in the illustration, but in student problems 6 or 8 points should be taken, and in practical work 12 to 24 divisions should be used. The first division point, H , is now revolved to meet the first radial division line OD_1 , thus giving the point H_1 , where a line H_1E is drawn perpendicular to H_1O . This line H_1E represents the bottom of the follower disk AC with reference to the cam when the cam has turned through the angle AOH_1 . The points D_2 and K_1 are obtained in the same manner as was H_1 and corresponding perpendiculars are drawn, as at D_2D_4 and K_1K_2 . As smooth a curve as possible is now drawn tangent to these perpendiculars and the points of tangency marked as at H_2, D_4 , and K_2 . This smooth curve, AG , is the working surface of the cam.

79. The size of the follower must also be determined. The most satisfactory way of doing this is to find, first, the locus, or path, of the line of contact between the periphery of the cam and the follower disk. This is obtained by considering that when H_1 is at H , the point of tangency H_2 is at H_3 , the length HH_3 being equal to H_1H_2 . Likewise, when D_2 is at D , D_4 is at D_5 , and the same for the other points of tangency. The dash line curve through the points $AH_3D_5K_3 \dots$ is the locus of contact between the cam and the follower. The point L is the extreme point of this curve and if the follower were not offset, the length of an ordinary toe or flat extension of the follower would have to be at least equal to $N'X'$. If the follower is offset, say by the amount $N'M'$ ($=N''M''$), the radius of the disk will have to be at least equal to $N'L'$, and the extreme line of contact will be $L'J'$. The other extreme line of contact will be a similar line through L'' , and the area of the flat disk which will

be subject to wear will be the annular surface between the periphery and the dashline circle whose radius is $N' A'$. As to the wear on the cam itself, there would be pure sliding of the curved surface $A G$ on the flat surface $A X$ if the follower were not offset. With an offset follower there is an effective turning radius equal to the offset

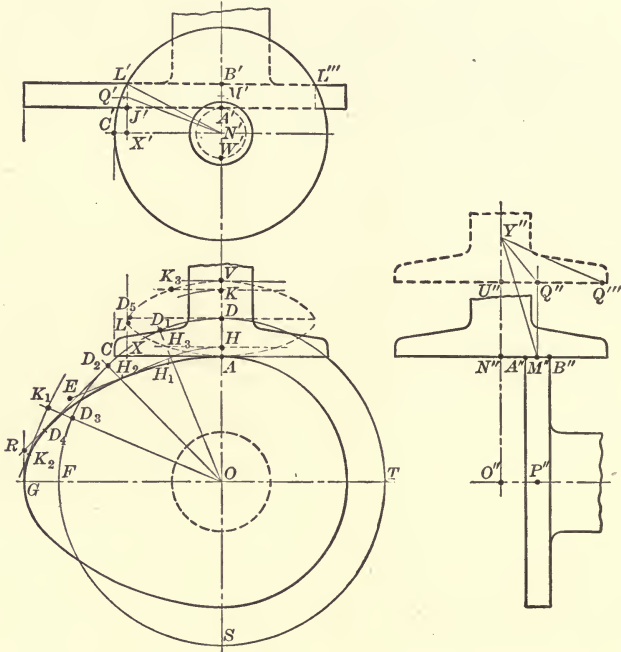

FIG. 44.—(Duplicate). PROBLEM 7, CAM WITH FLAT SURFACE FOLLOWER—MUSHROOM CAM

$N' M'$ tending to rotate the follower about its axis $N'' Y''$, and this changes the action of the cam on the follower entirely by causing part rolling and part sliding.

80. The pressure angle in this form of cam must be considered differently from cams which operate against rollers. In roller follower cams it is the angle between the normal to the cam surface and the line of action of the follower that determines the side pressure on the bearings, whereas in flat surface followers it is the distance that the line of contact is away from the line of action that determines it. This distance varies constantly, and in the illustration in Fig. 44 the limits of variation are $M' N'$ and $Q' N'$. These are, in reality, lever arms on which the pressure acts to produce a turning moment

which must be resisted by the follower guides. Since there can be no pure rolling action between the cam and follower in constructions of this type, there is nothing to be gained in this particular by a large offset. On the contrary, there is much to be lost, due to the large turning moment on the follower rod. A fair guide as to the offset would be to keep the angle formed by the center line $Y'' O''$ of the follower motion and the line $Y'' M''$ or $Y'' Q''$ joining the center of the bearing with the midpoint of the line of contact, to within, say, 30° , or any other maximum value that circumstance might warrant. The angle here defined might be termed the pressure angle in this type of cam. The minimum pressure angle, $N'' Y'' M''$, is seen in its true size, while the maximum pressure angle as projected at $U'' Y'' Q''$ must be revolved about $U'' Y''$ as an axis until $U'' Q''$ equals $N' Q'$, when it will appear in its true size as at $U'' Y'' Q'''$.

81. LIMITED USE OF CAMS WITH FLAT SURFACE FOLLOWERS. Cams with followers of this type are not well adapted, in general, for cases in which the follower must have specified velocities during its stroke. If the follower is required only to move from one end of its stroke to the other in a given period of time, independently of all intermediate velocities, this form of construction may be readily applied. The principal difficulties to be met in the building of these cams, when the intermediate velocities are specified, are, first, the large time angles necessary for a desired follower motion, or, second, a comparatively large cam. The cause of these difficulties may be pointed out in Fig. 44, where it may be seen that the construction point, K_1 , might have been so much further out radially that the perpendicular line, $K_1 K_2$, would have passed to the left of R and it would have been impossible to draw the smooth cam curve $A G$ tangent successively to *all* the perpendiculars. The limiting practical case appears when any three successive construction lines meet in a point, in which event the cam will have a sharp edge and be subject to excessive wear at that point. This subject is further considered in paragraph 106.

82. If one is not limited in the time, or angle, in which the follower must do its work; or, if not limited in the size of the cam, this form of construction may be used for any set of velocity values so long as they produce a working surface which always curves outward or which has an edge which points outward.

83. EXERCISE PROBLEM 7a. Required a radial periphery cam to operate an offset follower which has a flat surface perpen-

dicular to the line of motion instead of a roller, the follower to move:

- (a) Up 3 units in 90° on the crank curve.
- (b) Down 3 " " 90° " " " "
- (c) Rest for 180° .

Take cam disk to be one unit thick and the follower offset equal to two units measured from center of cam disk. Find and mark the locus of contact, also the size of the follower disk and the area of follower surface subject to wear.

84. CAMS FOR SWINGING FOLLOWER ARMS. In the previous problems the motion of the center of the follower roller has been in a straight line. When the center of the roller moves in a curve a different method of construction is used to advantage. Cams with swinging followers are illustrated in Figs. 45 and 46, the arc of swing AV of the follower having its extremities on a radial line in the former illustration; and on an arc which, continued, passes through the center of the cam in the latter illustration. These two forms of construction, although apparently differing in only a slight detail, give quite different results and each has its own particular field of usefulness. A comparison of the results will be given in paragraph 95 after a problem in each case has been worked out.

85. PROBLEM 8. CAM WITH SWINGING FOLLOWER ARM, ROLLER CONTACT—EXTREMITIES OF SWINGING ARC ON RADIAL LINE. Required a radial periphery cam to operate a roller follower where the follower arm swings about a pivot and where the two extreme positions of the center of the roller lie on a radial line. The chord of the swinging arc of the roller center is to be 4 units and the length of the follower arm 8 units. The follower arm to swing:

- (a) Out full distance on 90° on parabola curve.
- (b) In " " " 90° " crank "
- (c) And to remain at rest for 180° .

86. A different method of construction from any thus far employed is used in problems of this kind because it gives the simplest and most accurate layout for the pitch surface. Briefly, the method to be used consists in revolving the follower through the 360° around the cam while the cam remains stationary, and drawing the follower in a number of its phases while on the way around. One of the phases is represented in full by the dash lines $C_{10} Y_2 Y_3$ in Fig. 45.

87. The angle which causes pressure against the follower bearings is also different in this form of cam from any of the others. An inspection of Fig. 45 will show that, in general, the normal line of

pressure, AV at A , between the cam surface and the roller is not at right angles to the position of the follower arm, and, therefore, that the resultant total pressure has a component along the arm, tending to place it in compression and throwing a corresponding pressure on the follower bearing at C . The pressure angle at A is shown by $-a$, the minus sign indicating compression in the swinging arm. When K_1 is at K the pressure angle will be $+c$, the plus sign indicating tension in the follower arm. A disadvantage of the sign changing from $+$ to $-$, etc., is that as soon as the bearings wear there will be noise at that point.

88. The detail for the construction of problem 8 is taken up by computing the diameter of the pitch circle first, as in previous problems. This computation, however, serves only as a guide, for the assigned pressure angle will be both increased and decreased by amounts depending on the radius of the follower arm and the characteristics of the base curve which is used. For computing the pitch circle then, an assigned pressure angle factor for 30° will be assumed in the expectation that the final maximum angle will not

exceed 40° . From formula 1, paragraph 29, $d = 114.6 \frac{4 \times 3.46}{90}$

$= 17.62$ for the parabola curve; and $d = 114.6 \frac{4 \times 2.72}{90} = 13.86$

for the crank curve assignment. The radius of the pitch circle is thus found to be 8.81 units.

89. Having determined the radius OD , Fig. 45, for the pitch circle, the given chord of 4 units is laid off with equal parts on each side of D , thus locating the ends of the swinging arc AV on the radial line OD as required. With A and V as centers and a radius of 8 units for the length of the follower arm, strike arcs which will intersect at C and give the fixed center for the follower arm. The arc AV , showing the path of the center of the follower roller is now drawn.

90. Points on the pitch surface AV_1A_2F are found, in brief, by revolving the arm CA around O , swinging it a proper amount on its center C as it revolves. In detail this is accomplished by laying off the arc CC_6 equal to 90° , and dividing it into a number of equal parts, say six. Divide the arc AJ into three unequal parts, as at H and I , for the parabola curve. Lay off the points L and K in the same way. Then with CA as a radius and with $C_1, C_2 \dots$ as centers draw the arcs passing through $H_1, I_1 \dots$. Again, with

O as a center, swing arcs through $H, I \dots$ until they meet the arcs already constructed. The intersections of these arcs, as at $H_1, I_1, J_1 \dots$ will be the points on the desired pitch surface AV_1 . The determination of the pitch surface for the crank curve is found by laying off the second 90° assignment from C_6 to C_{12} and dividing it into six parts. The arc $A_1 V_1$ is divided by projecting the points $U W \dots$ of the crank circle to the points $U_1 W_1$ on the arc. The constructions for the points $U_2, W_2 \dots$ are the same as for the previous part of the pitch surface, as described above.

91. EXERCISE PROBLEM 8a. Required a radial periphery cam to operate a roller follower where the follower arm swings about a pivot and the two extremities of the swinging arc lie on a radial line. The 30° pressure angle factor to be used in computing the pitch circle radius. The chord of the swinging arc to be 3 units, the arm 9 units long, and to:

- (a) Swing out in $\frac{1}{3}$ revolution on the crank curve base.
- (b) Remain at rest for $\frac{1}{3}$ revolution.
- (c) Swing in in $\frac{1}{3}$ revolution on the parabola base.

92. PROBLEM 9. CAM WITH SWINGING FOLLOWER ARM, ROLLER CONTACT—SWINGING ARC, CONTINUED, PASSES THROUGH CENTER OF CAM. Required a radial periphery cam to operate a roller follower where the follower arm swings about a pivot, and where the center of the follower roller moves on an arc which, continued, passes through the center of the cam. The chord of the swinging arc of the roller center is 4 units and the length of the follower arm 10 units. The follower arm to swing:

- (a) Out full distance in 90° on parabola curve.
- (b) In " " " 90° " crank "
- (c) To remain at rest for 180° .

93. The procedure for this problem is the same as for Problem 8 in all respects except the layout of the arc of swing for the center of the follower roller. The pitch circle is drawn with radius OJ , Fig. 46.

With the center of the cam O and the pitch point J as centers draw arcs which intersect at C , the radius being equal to the length of the follower arm. Lay off JA and JV equal to each other and so that a chord drawn from A to V equals the four units assigned. A bent rocker, ACE , is introduced in Fig. 46 simply to change the direction of motion.

94. EXERCISE PROBLEM 9a. Required a radial periphery cam to operate a roller follower where the follower arm swings about a pivot,

and where the center of the follower roller moves on an arc which, continued, passes through the center of rotation of the cam. Take the length of follower arm as 12 units and its angle of swing 30° . Required that the follower arm:

- Swing out full distance in $\frac{3}{8}$ revolution, on crank curve.
- Remain at rest $\frac{1}{4}$ revolution.
- Swing in full distance in $\frac{3}{8}$ revolution, on crank base.

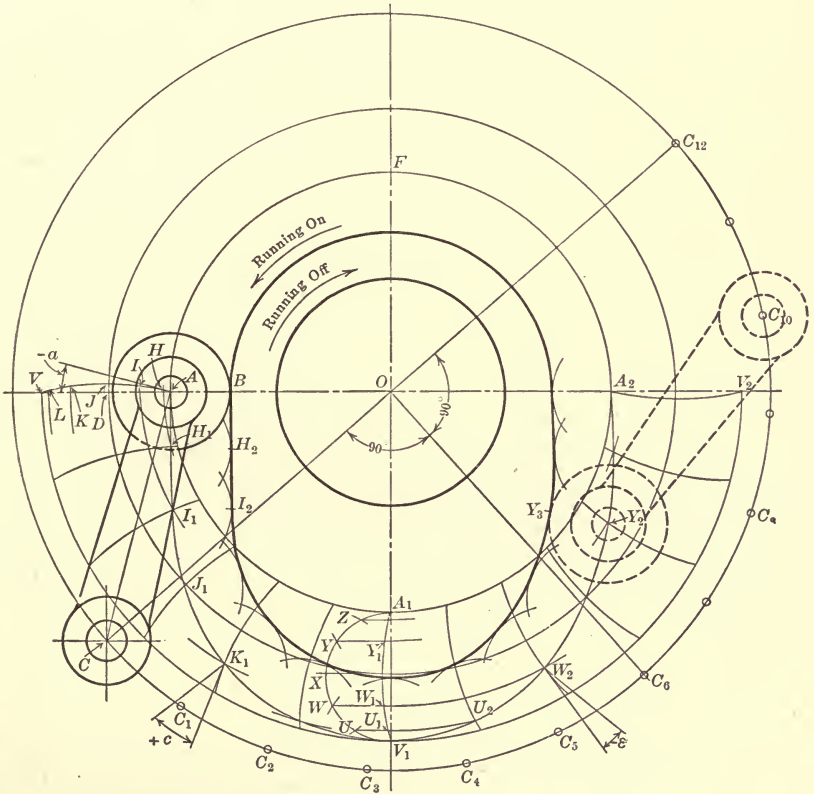

FIG. 45.—PROBLEM 8, CAM WITH SWINGING FOLLOWER ARM, ROLLER CONTACT—EXTREMITIES OF SWINGING ARC ON RADIAL LINE

95. EFFECT OF LOCATION OF SWINGING FOLLOWER ARM RELATIVELY TO THE CAM. When the swinging follower arm is mounted so that the extremities of the arc of travel of roller center are on a radial line, as in Problem 8, the pressure angles on the out and in strokes will be approximately the same. When the follower roller center

moves on an arc which, continued, passes through the center of the cam, as in Problem 9, the pressure angle will be larger, on the average, on the one stroke than on the other. Consequently, the type shown in Problem 8 would have an advantage where equal amounts of work were to be done on both strokes, and the type

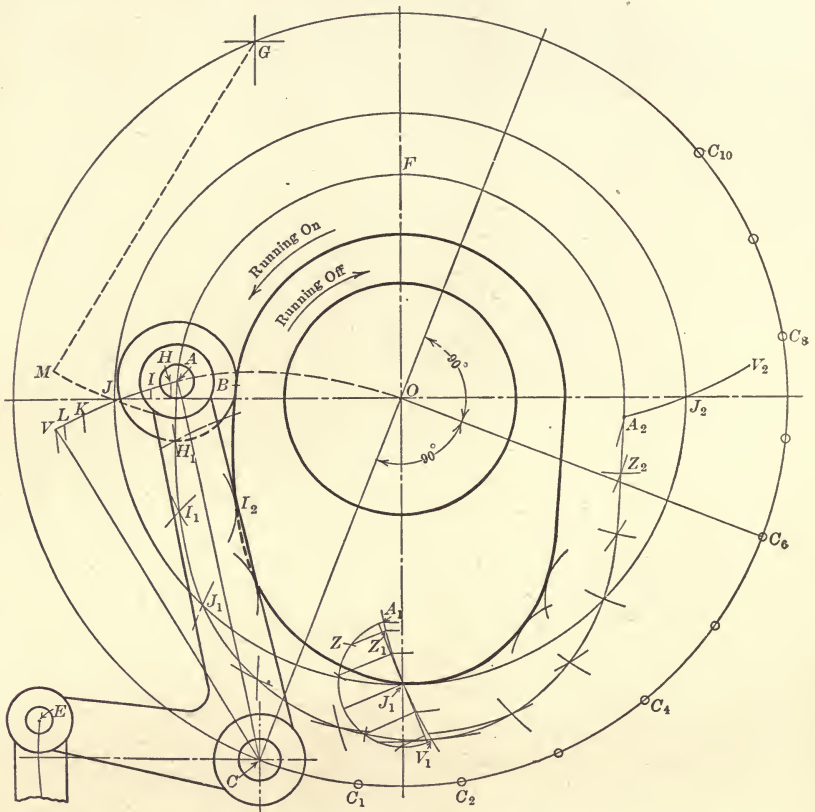

FIG. 46.—PROBLEM 9, CAM WITH SWINGING FOLLOWER ARM, ROLLER CONTACT—SWINGING ARC, CONTINUED, PASSES THROUGH CENTER OF CAM

shown in Problem 9 would be of advantage where heavy work was to be done on one stroke only. Either the out or in stroke may be selected for heavy work, according to the position taken for the center C or G of the swinging arm, Fig. 46, the direction of turning of the cam being the same. In many cases the type shown in Problem 9 allows the pressure angle to be maintained on one of the strokes so that there is pressure in only one direction on the shaft C .

Cams operate smoother when "running off" than when "running on." A cam is said to be "running off" when the point of contact on the working surface of the cam is moving away from the fixed center of the swinging follower arm. A cam of the type illustrated in Problem 8 will have an axis of symmetry where the same data are assigned for the out and in stroke, whereas the cam illustrated in Problem 9 will be quite unsymmetrical for same data.

96. POSITIVE-DRIVE FACE CAMS. The pitch surfaces for face cams are laid out in exactly the same manner as pitch surfaces for radial periphery cams. The only additional feature is that a working surface is drawn to touch each side of the roller.

97. PROBLEM 10. FACE CAM WITH SWINGING FOLLOWER. Construct a face cam for a swinging follower arm, roller contact. Arm to be 12 units long and to swing through 30° . Required that the arm shall:

(a) Swing full out on the combination curve while the cam makes $\frac{5}{8}$ revolution.

(b) Swing full in on the combination curve while the cam makes $\frac{3}{8}$ revolution.

98. In order to compute the radius of the pitch circle it is necessary to find the travel, or the approximate travel, of the center of the follower roller. This is graphically done by making a separate sketch, as in Fig. 47, drawing the angle XYZ equal to 30° , drawing the arc ZX with a radius of 12 units, and measuring the chord ZX , which is found to be 6.2 units. Or, this value may be found trigonometrically, without any drawing, by taking $12 \times 2 \sin 15^\circ = 6.2$. The radius of the pitch circle will then be:

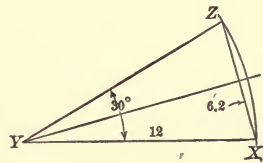

FIG. 47.—TO FIND CHORD MEASURE OF TRAVEL OF POINT ON SWINGING ARM

$$6.2 \times 2.27 \times \frac{8}{3} \times \frac{1}{3.14} \times \frac{1}{2} = 6.0 \text{ units.}$$

99. To construct the cam, the value just found is laid off at OJ , Fig. 48, and the pitch circle drawn. With the combination curve a cam chart, a partial one at least, must be drawn. To do this with least effort, select any point J' in line with the pitch point J and draw the line $J'V'$ at the given pressure angle, 30° in this case, until it is 6.2 units long. With V' as a center, draw arc $J'A'$ and also draw a tangent to it at J' and produce it to S' , where $R'S'$ equals

100. EXERCISE PROBLEM 10a. Required a face cam for a swinging follower arm, roller contact. Arm to be 10 units long. Center of roller to swing through an arc whose chord is 4 units, and this arc, when continued, to pass through center of cam. The arm to:

(a) Swing to the right on combination curve while cam turns 180° .

(b) Swing to the left on combination curve while cam turns 180° .

101. PROBLEM 11. CAM WITH SWINGING FOLLOWER ARM, SLIDING SURFACE CONTACT. Required a radial periphery cam to operate a swinging arm having a construction radius of 9 units. Sliding surface contact between cam and follower. The arm to:

(a) Swing up 4 units on the crank curve base while the cam turns 120° .

(b) Swing down 4 units on the crank curve base while the cam turns 120° .

(c) Remain at rest for 120° .

102. This type of cam and follower is illustrated in Fig. 49. The line of pressure between cam and follower is always normal to the follower surface and consequently there is no component of pressure in the bearing at C due to pressure angle. This cam is, therefore, independent of a pitch circle based on pressure angle, and the pitch circle may be taken any size. Where one has no special guide in assuming a starting size for the cam, the usual computation for pitch circle for a 30° pressure angle may give good average results. According to this, the pitch radius OD will be,

$$4 \times 2.72 \times 3 \times \frac{1}{3.14} \times 2 = 5.2 \text{ units}$$

AV equals 4 units and AC equals 9 units. The point A is taken, for construction purposes, as a point on the follower arm where the angular velocity of the arm is measured. It will be at the points $H, I, J \dots$ on the arc AV at the end of equal succeeding intervals of time.

103. The method of constructing the cam in this problem is identical with the method used in Problem 8 in so far as the follower arm is swung around the cam, and its position with respect to the cam center at equal time intervals is drawn. The departure from the method of Problem 8 consists in drawing the cam outline as an envelope to these follower-arm positions. For example, in Fig. 49, at the end of the third time interval the pivot C has been revolved to C_3 and the point A of the follower arm has moved out

to J_1 . The point J_1 is found at the intersection of two arcs, one obtained with CA as a radius and C_3 as a center, and the other with OJ as a radius and O as a center.

When a number of positions of the follower arm, such as $C_3 J_1$, have been obtained, the smoothest possible curve is drawn tangent successively to each of them, and this curve is the working surface

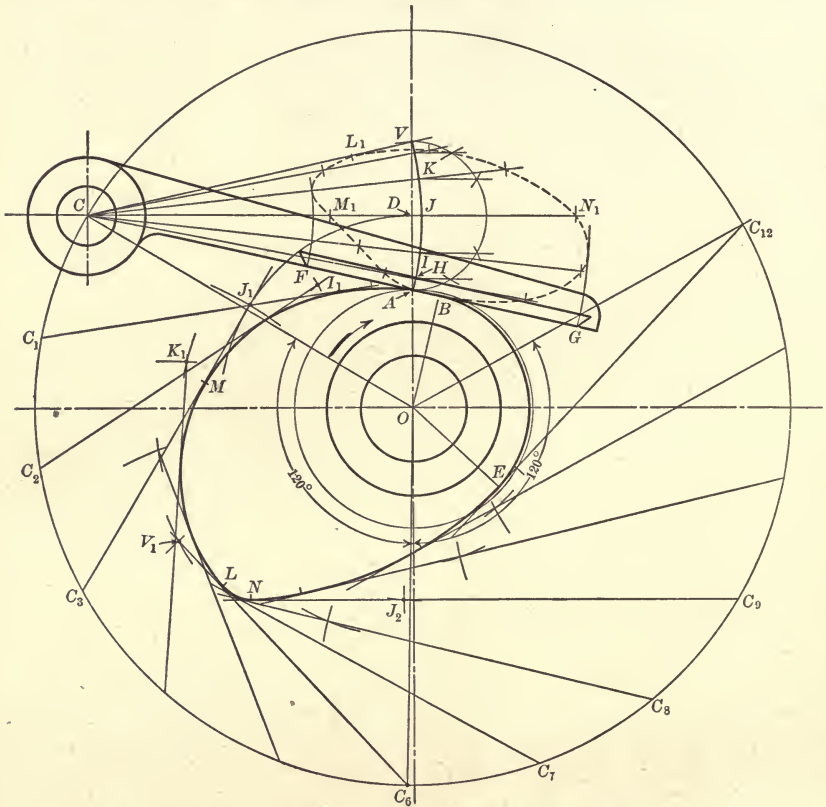

FIG. 49.—PROBLEM 11, CAM WITH SWINGING FOLLOWER ARM, SLIDING CONTACT

of the cam. This curve is tangent to $C_3 J_1$ at M , and if the distance $C_3 M$ is laid off at $C M_1$, the point M_1 will be the actual point of tangency between the cam surface and follower arm when the arm is halfway through its swing, or when A is at J . Similarly when C_9 is at C the point of tangency between cam and follower arm will be at N_1 .

104. The locus of the point of contact between the cam and follower, relatively to the frame of the machine, is shown by the

dash closed curve through M_1 and N_1 . By drawing arcs tangent at the extremities of this dash curve, using C as a center in both cases, the points F and G on the follower surface are obtained and the distance FG will be the part of the follower exposed to wear from the rubbing of the cam. This part of the follower arm may be designed with a shoe, as indicated, which may be replaced when worn.

105. It should be specially noted that the shortest radius of the cam is not OA , but OB . The point B is found by drawing a perpendicular to CG through O .

The very decided lack of symmetry should also be noted, the curve BL being used to lift the arm, and the curve LE to lower the arm, the swinging velocities of the arm being the same in both directions.

106. DATA LIMITED FOR FOLLOWERS WITH SLIDING SURFACE CONTACT. The data for this type of cam construction are extremely limited when the swinging velocity of the arm is assigned. The limitations are that the working surface of the cam must be drawn *tangent to every construction line in succession*, and that it must be convex externally at all points. In most arbitrary assignments of data the construction line through C_9 , for example, would intersect the line through C_7 before it cut the line through C_8 . In this case it would be impossible to draw a smooth working curve tangent, *successively*, to the lines through C_7 , C_8 , and C_9 . This is illustrated more clearly in Fig. 51 and will be more evident after the limiting case is described.

The limiting case for flat surface followers with sliding contact occurs where three or more of the construction lines meet in a point, as at N in Fig. 50. In this case the working surface of the cam

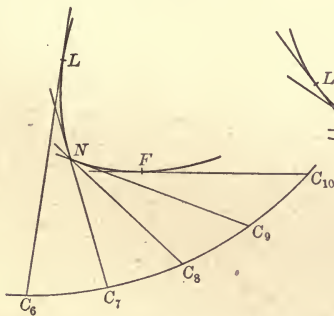

FIG. 50.—LIMITING CASE FOR STRAIGHT EDGE FOLLOWER WITH SLIDING CONTACT

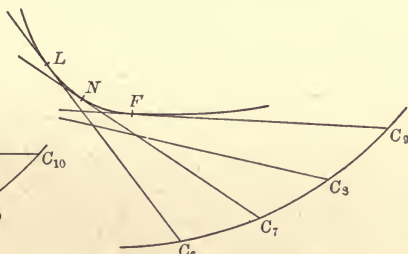

FIG. 51.—IMPOSSIBLE CASE FOR STRAIGHT EDGE FOLLOWER WITH SLIDING CONTACT

would have a sharp edge. In this type of cam it is necessary to use more construction lines than in other types, because it is possible to have the construction lines so far apart that such a case as is shown in Fig. 51 might not evidence itself at all. For example, if the distance $C_9 C_7$ were the unit space for construction lines, instead of $C_9 C_8$, the smooth convex curve FNL could be drawn tangent to lines through $C_9, C_7 \dots$ without the error showing itself.

107. If it is required of this cam only that it shall swing a follower arm through a given angle in a given time, without regard to the

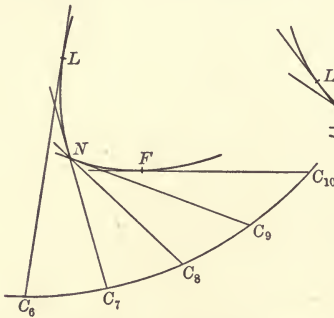

FIG. 50.—(Duplicate.) LIMITING CASE FOR STRAIGHT EDGE FOLLOWER WITH SLIDING CONTACT

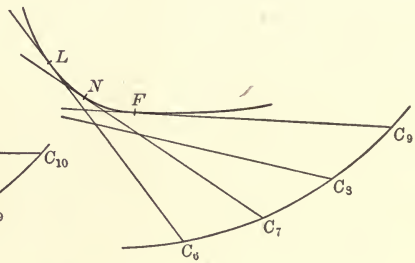

FIG. 51.—(Duplicate.) IMPOSSIBLE CASE FOR STRAIGHT EDGE FOLLOWER WITH SLIDING CONTACT

intermediate velocities of the arm, it may be as widely used as any other type of cam. In this case only the innermost and outermost positions of the arm would be drawn, as at $CA, C_6 V_1$, and $C_{12} E$, Fig. 49, and a smooth convex curve drawn tangent to these lines. Such construction, however, might give an irregular or jerky motion to the follower. Whether it did or not could be readily determined by laying off a number of equal divisions, as at $C_1, C_2 \dots C_{12}$; drawing lines, such as $C_3 J_1$, tangent to the assumed smooth convex working surface; and revolving $C_3 J_1$ back to CJ . After doing this with other construction lines a series of points, such as $H, I, J \dots$ would be determined and the spaces between them would represent the distances traveled by A on the follower arm during successive equal intervals of time.

108. EXERCISE PROBLEM 11a. Required a radial periphery cam for a swinging follower arm, sliding surface contact. Arm to be 10 units long to the point which is used to measure the angular velocity, and this point to move through an arc which is measured by a chord of 4 units. The arm is to:

(a) Swing full out with uniform acceleration and retardation while the cam turns $\frac{3}{8}$ revolution.

(b) Swing in with the same angular motion in $\frac{3}{8}$ revolution.

(c) Remain stationary for $\frac{1}{4}$ revolution of the cam.

109. TOE AND WIPER CAMS. In this form of cam construction the cam or "wiper" OC , Fig. 52, oscillates or swings back and forth through an angle of 120° or less, instead of rotating continuously the full 360° as it does in all cams thus far considered. The follower or "toe" AW is usually a narrow flat strip resting on the curved periphery of the cam, and moving straight up and down. There is sliding action between the wiper and the toe.

110. PROBLEM 12. TOE AND WIPER CAM. Required a wiper cam to operate a flat toe follower which shall move:

(a) Up 4 units with uniform acceleration all the way while the cam turns counterclockwise 45° with uniform angular velocity.

(b) Down 4 units with uniform retardation all the way while the cam turns clockwise 45° with uniform angular velocity.

111. The detail of construction for this class of problem is identical with that described for the mushroom cam in Problem 7, it being observed that the two cams differ only in that the mushroom cam turns through the full 360° instead of 45° as in this problem, and the mushroom follower is circular instead of rectangular. Neither of these differences nor the offset of the mushroom follower affect the similarity of construction for the two types of cams. Therefore, only a brief review of the general method of construction for the present problem will be given here.

112. Inasmuch as the line of pressure between cam and follower is always parallel to the direction of motion of the follower in problems such as this, there is no pressure angle in the ordinary sense. If a computation for size of cam is made in the usual way, the radius of the pitch circle will figure to be unnecessarily large, due principally to the fact that only a 45° degree turn of the cam is allowed for the upward motion of the follower.

A radius OA , Fig. 52, which allows for radius of shaft, thickness of hub, etc., is assumed, and the follower motion of 4 units is laid off at AV . This distance is divided into four unequal parts at $H, I \dots$ which are to each other as 1, 3, 5, and 7, thus giving uniform acceleration all the way up. The angle $A'OB$ of the cam is laid off 45° and is divided into four equal time parts. The follower or toe surface AW is then moved up the distance AH and revolved through the angle $A'OI$ to the position H_1H_2 which is marked. Simi-

larly $A W$ is next moved to $I I_3$ and revolved to $I_1 I_2$. The smoothest possible convex curve is then drawn to the lines $H_1 H_2, I_1 I_2 \dots$ and this curve becomes the working surface of the wiper.

The necessary working length for the wiper is found to be $A V_2$, and, adding a small arbitrary distance, $V_2 C$, the total length is taken

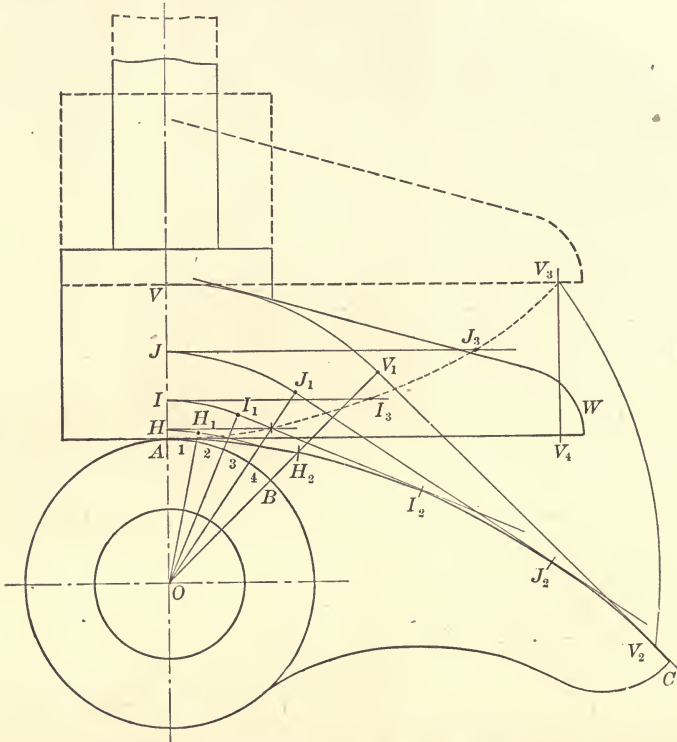

FIG. 52.—PROBLEM 12, TOE AND WIPER CAM

as $A C$. The total length of the toe $A W$ will be equal to $V_1 C$. The long dash lines in Fig. 52 indicate the highest position of the toe and wiper, and the short dash-line curve marks the locus of contact between the wiper and toe. This curve is obtained by making, for example, $J J_3$ equal to $J_1 J_2$.

113. MODIFICATIONS OF THE TOE AND WIPER CAM. The toe and wiper cam constructions are commonly used. In the present elementary problems the cam or wiper is assumed to oscillate with uniform angular velocity, whereas in practice it usually has a variable angular velocity due to the fact that it is operated through a rod which is connected at the driving end to a crank pin or eccentric

whose diameter of action corresponds to the swing of the wiper cam. The follower toe may be built with a curved instead of a straight line, by a slight modification in detail which consists in drawing the curved toe line in place of the straight lines, $H_1 H_2, I_1 I_2 \dots$ as shown in Fig. 52. These points, together with a consideration of the amount of slip between the surfaces in this type of cam and a discussion of the necessary modification to secure pure rolling in cams of this general appearance, are subjects for more advanced work than is covered by the present elementary problems.

114. EXERCISE PROBLEM 12a. Required a wiper cam to operate a flat toe follower which shall move:

(a) Up 3 units with uniform velocity while the cam turns 60° in a counterclockwise direction with uniform angular velocity.

(b) Down 3 units with uniform velocity while the cam turns 60° in a clockwise direction with uniform angular velocity.

115. YOKE CAMS. Yoke cams are simple radial periphery cams in which two points of the follower, instead of one, are in contact with the working surface. The contact points are usually diametrically opposite to each other. Roller contact is generally used and the centers of the rollers are a fixed distance apart. The yoke cam gives positive motion in both directions, and does not depend on a spring or on gravity to return the follower as do all other cams thus far considered, excepting the face cam.

116. PROBLEM 13. SINGLE-DISK YOKE CAM. Required a single radial cam to operate a yoke follower with a maximum pressure angle of 30° :

(a) Out 4 units in 45° turn of the cam, on crank curve.

(b) In 4 " " 90° " " " " " " " "

(c) Out 4 " " 45° " " " " " " " "

117. With a single radial cam for a yoke follower, data may be assigned only within the first 180° . The reason for this will appear presently.

Compute the radius of pitch circle as in ordinary radial cam problems. It is found to be 13.86 units and is laid off at OD , Fig. 53. The pitch surface, $A D_1 V_1 A_1 V_2$, is found in the usual way. Then the diametral distance, AV_2 , will be the fixed distance between the centers of the rollers, and if this distance is laid off on diametral lines, as from $I_1, K_1 \dots$, the points $W, X \dots$ on the complementary pitch surface will be located. A size of roller AB is next assumed and the working surface BB_2 is constructed. The maximum radius of the working surface is finally located, as at OB_2 . A small amount

is added to this for clearance and the total laid off at OZ , thus giving the width of yoke necessary for an enclosed cam.

118. LIMITED APPLICATION OF SINGLE-DISK YOKE CAM. In yoke cams constructed from a single disk the data are limited in two ways:

First, data can be assigned for the first 180° only, because the pitch surface for the second 180° must be complementary to the pitch surface in the first 180° .

Secondly, the complementary pitch surface cannot approach any nearer to the center of rotation of the cam than does the pitch surface

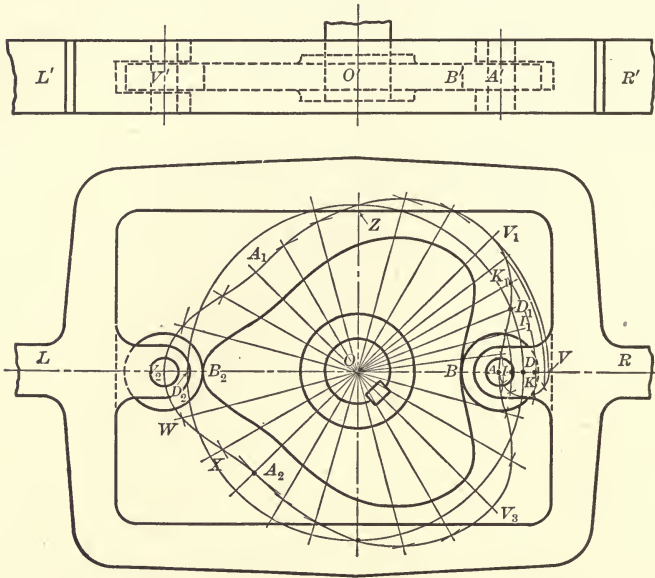

FIG. 53.—PROBLEM 13, SINGLE-DISK YOKE CAM

in the first 180° , otherwise the follower will have a greater motion than that which was assigned to it.

To illustrate this second case, assume that item (c) had been changed in the data for Problem 13 so as to specify that the follower should remain at rest while the cam turns 45° . Then the pitch surface of the cam for the first 180° would have been AV_1A_1C , Fig. 54, instead of $AV_1A_1V_2$. The diametral distance AC would then have been the distance between roller centers, and would have been also the distance used in determining the complementary pitch surface CE_1A_3A which, it will be noted, approaches closer to O than does AV_1C . When E_1 of the complementary surface

reaches the center line OD , the center A of the roller will be at E and the roller will have traveled the distance AE in addition to the travel AV which was assigned. Furthermore, the pressure angle will be very high when F crosses the line OD_2 . With the data which gives the pitch surface AV_1C , the yoke follower will move just twice the assigned distance. This double motion will not be continuous, as the follower will be at rest for a definite period represented by A_1C . Even if the data were such that A_1 should fall at C there would be a momentary period of rest for the follower at the middle of its stroke.

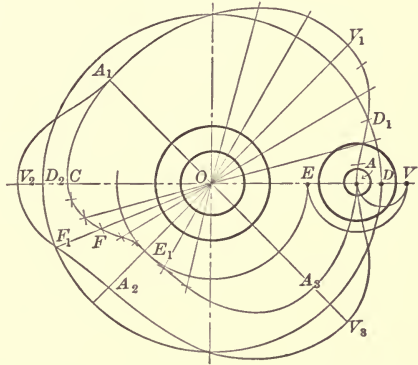

FIG. 54.—ILLUSTRATING LIMITED APPLICATION OF SINGLE-DISK YOKE CAM

Summing up, the desired travel, pressure angle, and follower velocity will be obtained in single-disk yoke cams, only when the data are such as to have the follower at the extreme opposite ends of its stroke at the zero and 180° phases. In other cases increased travel, increased pressure angle, and irregular follower velocities will have to be considered.

All of the limitations of the single-disk yoke cam may be avoided by using the double disk cam as illustrated in Problem 14.

119. EXERCISE PROBLEM 13a. Required a single-disk radial cam to operate a yoke follower with a maximum pressure angle of 30° :

- In 6 units in 60° turn of the cam on parabola curve.
- Out 6 " " 45° " " " " " " " "
- At rest for 30° " " " " " " " "
- In 6 units in 45° " " " " " " " "

120. PROBLEM 14. DOUBLE-DISK YOKE CAM. Required a double-disk cam to operate a yoke follower with a maximum pressure angle of 30° :

- To the right 6 units in 150° turn of the cam, on the crank curve.
- To the left 6 units in 90° turn of the cam, on the crank curve.
- To remain stationary for 120° turn of the cam, on the crank curve.

121. The detail of construction for the primary disk is the same as in previous problems involving radial cams. In this problem, then, the radius of the pitch circle is $6 \times 2.72 \times 4 \times \frac{1}{3.14} \times \frac{1}{2} = 10.4$ units and this is laid off at OD , Fig. 55. The forward driving pitch surface, $AH_1V_1I_1A$, is constructed in the regular way as indicated by the construction lines.

122. The diameter DC of the pitch circle is next taken as a constant and its length is laid off on diametral lines from successive

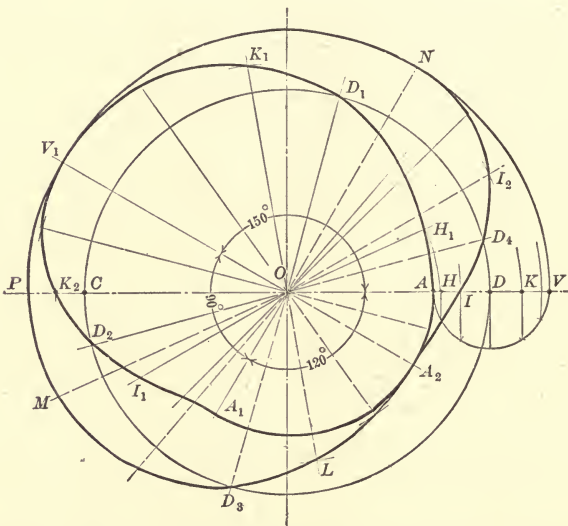

FIG. 55.—PROBLEM 14, DOUBLE-DISK YOKE CAMS, DETAIL CONSTRUCTION

points on the primary pitch surface, thus giving the secondary or return pitch surface. For example, the point P on the secondary surface is found by making $AP = DC$; the point M by making $H_1M = DC$ This second cam disk has a pressure angle of 30° at D_4 , the same as the primary disk has at D_2 . Had any diametral length other than DC been taken in this problem as a constant for constructing the second cam, the pressure angle at D_4 would have been greater or less than the assigned 30° . It does not follow that the diameter of the pitch circle should be used as a constant for generating the complementary cam. The determining factor, in selecting a constant diametral length is that the maximum pressure angle on the second cam should not exceed the assigned value.

123. To avoid intricate line work, only the detail drawing for the construction of the pitch surfaces for this problem is shown in Fig. 55. The pitch surfaces are then redrawn in Fig. 56 and the working surfaces and the yoke constructed.

The working surface of the primary or forward-driving cam is shown at $B E F G B$, Fig. 56, and is constructed in the same way as

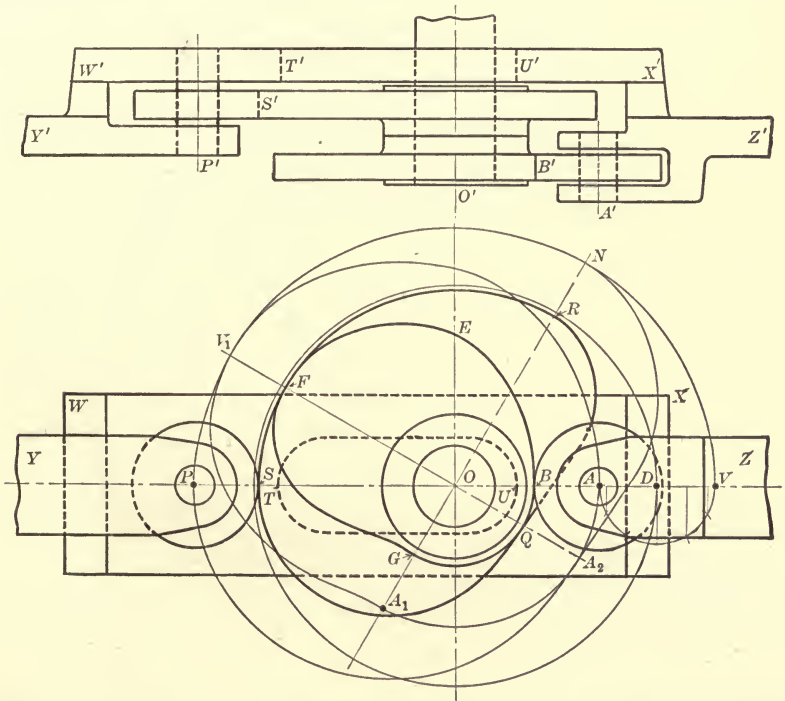

FIG. 56.—PROBLEM 14, DOUBLE-DISK YOKE CAMS SHOWING STRAP YOKE AND ROLLERS

in previous problems by drawing it as an envelope to successive roller positions. The working surface of the return cam is shown at $S Q R S$. A special caution to be observed at this point is that the *working surface* of the second cam cannot be obtained directly from the working surface of the first cam by using the diametral constant; the second cam pitch surface must be obtained first.

124. The form of yoke in yoke cams may vary, as illustrated for example by the box type which encloses the cam, Fig. 53, and by the strap type, Fig. 56. In the latter illustration the strap $W X$ has a longitudinal slot $T U$ permitting it to move back and forth astride the shaft without interference. The guide arms of the

yoke are shown at Y and Z . In all yoke constructions it is desirable to have all the forces acting in as nearly a straight line, or in a plane, as possible. In Fig. 53 this is obtained, as may be noted in the top view where the longitudinal center lines of cam disk, cam roller, yoke and yoke guides are all in the same plane. In Fig. 56 the yoke guides, Y' and Z' , are placed in a line lying between the cam disks, B' and S' , so as to have the forces balanced to a greater degree than they would be if the guides were in line with the strap $W'X'$.

125. EXERCISE PROBLEM 14a. Required a double-disk cam to operate a yoke follower with a maximum pressure angle of 30° , as follows:

- (a) To the right 4 units in 90° on the parabola base.
- (b) Dwell for 30° .
- (c) To the right 4 " " 105° " " " "
- (d) " " left 8 " " 135° " " " "

126 PROBLEM 15. CYLINDRICAL CAM WITH FOLLOWER THAT MOVES IN A STRAIGHT LINE. Required a cylindrical cam to operate a reciprocating follower rod:

- (a) To the right 4 units in 120° on the crank curve.
- (b) " " left 2 " " 120° " " " "
- (c) " dwell 120° .

The maximum surface pressure angle to be 30° .

127. The size of cylinder is found by a computation similar to that for radial cams, and in this problem the radius of the cylinder is,

$$4 \times 2.72 \times 3 \times \frac{1}{3.14} \times \frac{1}{2} = 5.2 \text{ units.}$$

This distance is laid off at $O'A'$ in Fig. 57, and the circle drawn. The distance AV , the travel of the follower, is laid off equal to 4 units and subdivided, according to the crank circle, at $H, I \dots$. The radius of the follower pin is assumed as at AS and this distance is laid off at CS , thus locating the edge of the cylinder. Make VD equal to AC . The circle representing the cylinder is next divided into three 120° divisions at $A', M',$ and Q' , as specified.

$A'M'$ is divided into six equal parts by the points $H', I' \dots$ which are projected over to meet the vertical construction lines through $H, I \dots$ at $H_2, I_2 \dots$. The latter points mark a curve on the surface of the cylinder. This curve is a guide for the center of the tool which cuts the groove. The finding of this curve and the construction of the follower pin and rod constitute the remaining essential work on this problem. If it is desired to show the groove

tion here used. Since the pitch cylinder should pass through the point where maximum pressure angle exists, the pitch cylinder in cams of this type would be one having a radius $O'B'$. The pitch surface of the cylindrical cam would be a warped surface, known as the right helicoid, and the intersection of this surface with the surface of the cylinder is the curve $RAEP R$ and is the guide curve for the cutting tool in milling out the groove for the pin. The sides of the groove are the working surfaces of the cam; they are indicated in the sectioned part of the front view of Fig. 57.

More exact methods for drawing the sides of the groove in a cylindrical cam, together with a more exact method for determining the maximum pressure angle, involve a knowledge of projections and an intricacy in drawing that make such work a proper subject for advanced study, and it will therefore be omitted in this elementary treatment, as it is totally unnecessary in most practical work.

129. EXERCISE PROBLEM 15a. Required a cylindrical cam to operate a sliding follower rod, with a maximum pressure angle of 40° :

- (a) 6 units to the right in 90° on the parabola base.
- (b) 6 " " " left " 270° " " " " "

130. PROBLEM 16. CYLINDRICAL CAM WITH SWINGING FOLLOWER.

Required a cylindrical cam to operate a swinging follower arm:

- (a) To the left 40° in 120° turn of the cam on the crank curve.
- (b) " " right 40° " 120° " " " " " " " "
- (c) Dwell for 120° turn of the cam.

The length of the follower arm is to be 9 units and the approximate maximum pressure angle is to be 30° .

131. The diameter for the cylindrical surface is found in the same manner as the diameter of the pitch circle in radial periphery cams. The data in this problem do not give directly the travel of the follower and so this value must be found first. The chord of a 40° arc having 9 units radius will be

$$9 \times 2 \times \sin 20^\circ = 9 \times 2 \times .342 = 6.2 \text{ units.}$$

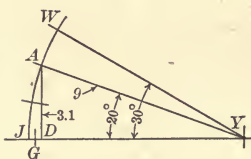

FIG. 58.—DETERMINING FOLLOWER TRAVEL IN SWINGING ARMS FOR COMPUTING PITCH DIAMETER

If a trigonometrical table is not at hand the arc may be drawn out as in Fig. 58 where half the given angle is laid out at AYJ by the simple expedient of subdividing a 30° arc by means of a dividers. The half chord AD is drawn and measured. It is equal to 3.1 units, thus making the chord of the whole arc of travel equal to 6.2 units.

This value is used in obtaining the diameter of the surface of the cylinder as follows:

$$6.2 \times 2.72 \times 3 \times \frac{1}{3.14} = 16.12 \text{ units.}$$

The circle $A'Q'M'$, Fig. 59, is drawn with a radius of 8.06 units.

132. The 120° angles assigned in the data are next laid out but not from the center line OR' as in previous problems. In mechanisms of all kinds where there is a swinging follower, it is a rule, unless otherwise specified, that the swinging pin should be the same dis-

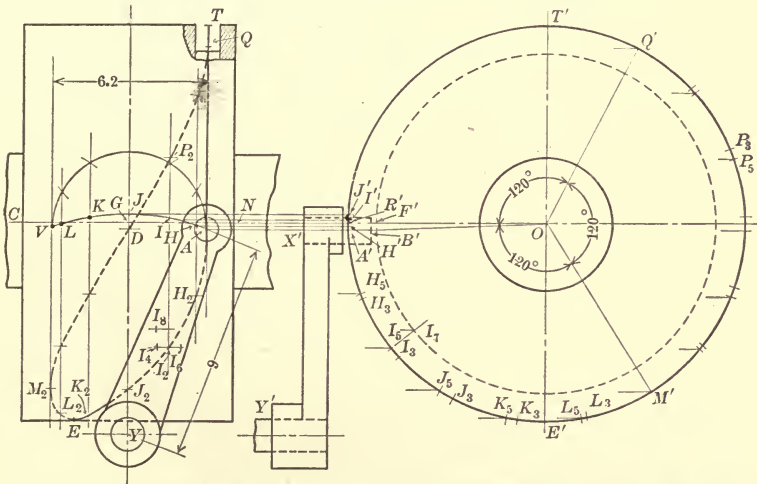

FIG. 59.—PROBLEM 16, CYLINDRICAL CAM WITH SWINGING FOLLOWER ARM

tance above a center line at the middle of its swing as it is below at the two extremities of its swing. In this case, then, the point G , Fig. 58, will be marked midway between J and D and the distance GJ laid off at GJ in Fig. 59. J will be the center of swing of the follower arm and the arc of swing of the follower pin will be AJV . J will be as much above the center line as A and V are below. The practical advantage of this detail in the layout is that it gives a maximum bearing length between the follower pin and the side of the groove.

133. The arc AJV , Fig. 59, is next divided at the points marked $H, I \dots$ according to the crank curve assignment, and vertical construction lines are drawn through these points.

The point A is now projected to A' and the radial line, $A'O$, is drawn. This becomes the base line from which to lay off the three

assigned timing angles of 120° , as shown at $A' O M'$, $M' O Q'$, and $Q' O A'$. The arc $A' M'$ is next divided into the desired number of equal construction parts, as at H_3, I_3, J_3, \dots

When H_3 reaches A' , the pin A will have swung not only over to H , but it will have moved up the distance $A' H'$ measured on the surface of the cylinder. Therefore, when H_3 reaches A' , it is the line through H_5 ($H_3 H_5 = A' H'$) on the groove center line that will be in contact with the pin center line. For this reason H_5 , instead of H_3 , is projected over to meet the construction line at H_2 . This latter point is on the guide curve for the cutting tool on the surface of the cylinder. Other points are found in the same way. Time may be saved by marking the points $A' H' I' J'$ on the straight edge of a piece of paper and transferring these marks at one time so as to obtain the points $I_5, J_5, \dots, P_5, \dots$

134. If it is required to show the surface bounding lines of the side of the groove it may be done quickly, although approximately, by laying off on a horizontal line, as at I_2 , the points I_4 and I_6 at distances equal to the radius of the pin. These will represent points on the curve. If it is required to show the bottom lines of the groove it may be done by projecting from I_7 and finding, for example, the point I_8 in the same way as I_4 was found.

135. EXERCISE PROBLEM 16a. Required a cylindrical cam to operate a swinging follower arm:

(a) To the right 6 units (measured on chord of follower pin arc) while cam turns 150° .

(b) Dwell while cam turns 120° .

(c) To the left 6 units while cam turns 90° .

The follower arm to be 8 units long and its rate of swinging to be controlled by the crank curve with a maximum approximate pressure angle of 40° .

136. CHART METHOD FOR LAYING OUT A CYLINDRICAL CAM WITH A SWINGING FOLLOWER ARM. This method is illustrated in Figs. 60 and 61. The data in this problem will be taken the same as in Problem 16, namely, that a follower arm of 9 units length shall: Swing through an angle of 40° to the left while the cam turns 120° ; through the same angle to the right while the cam turns 120° , on the crank curve in both directions; remain stationary while the cam turns 120° . The maximum pressure angle is to be approximately 30° .

137. To find the length of the chart, the chord that measures the arc of swing of the follower pin is first determined to be 6.2

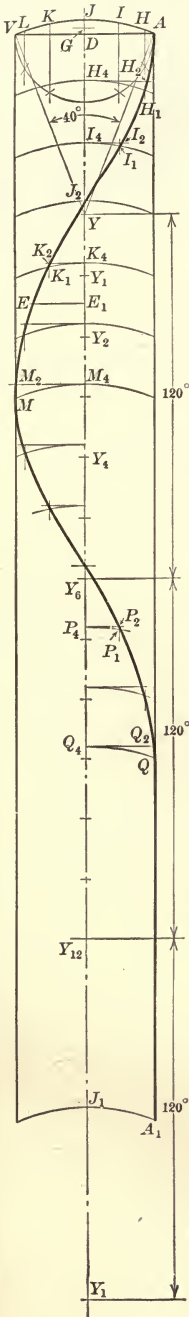

FIG. 60.—CHART FOR LAYING OUT CYLINDRICAL CAM WITH SWINGING FOLLOWER

units as explained in paragraph 131. The length of chart is

$$6.2 \times 2.72 \times 3 = 50.6 \text{ units,}$$

and this is laid off at $J J_1$, Fig. 60. The length of the follower arm is then laid off at $J Y$, and the follower-pin arc $A V$ drawn. This arc is subdivided at $H, I \dots$ according to the crank curve. The distance $Y Y_6$ is then laid off to represent 120° and its length will be equal to one-third the length of the chart. As many construction points as were used from A to V are then laid off between Y and Y_6 . With these as centers and $Y A$ as a radius draw a series of arcs to which the points $H, I \dots$ are projected, thus giving the base curve through the points $H_1, I_1 \dots$. Tangent to the series of arcs on the chart draw straight lines and mark the intercepts $H_4 H_2, I_4 I_2 \dots$.

138. Upon completing the chart, the surface of the cam is drawn as in Fig. 61, with a diam-

eter $E' T' = \frac{50.6}{3.14} = 16.12$. The width $C N$ of

the cylinder may be taken equal to the chord $A V$ of the arc of swing of the follower pin, plus twice the diameter of the pin.

139. The simplest general plan for transferring the cam chart to the surface of the cam is to consider the chart lines to be on a strip of paper, and that this paper is simply wound around the cylindrical surface of the cam, starting the point G of the chart at G on the center line of the cam. G on the chart is midway between J and D . Then the points $H_2, I_2 \dots$ of the base curve in Fig. 60 will fall at H_2, I_2 , in Fig. 61, giving the surface guide curve for the center of the cutting tool.

140. The detail necessary to actually locate the points H_2, I_2 in Fig. 61 is accomplished by projecting J to J' and laying off the as-

signed 120° divisions, and also the subdivisions from this latter point. The 120° divisions are shown at M' , Q' , J' ; the equal subdivisions at $H_3 I_3$ From these latter points, lines are projected to the front view and the lengths $H_4 H_2$, $I_4 I_2$ are transferred

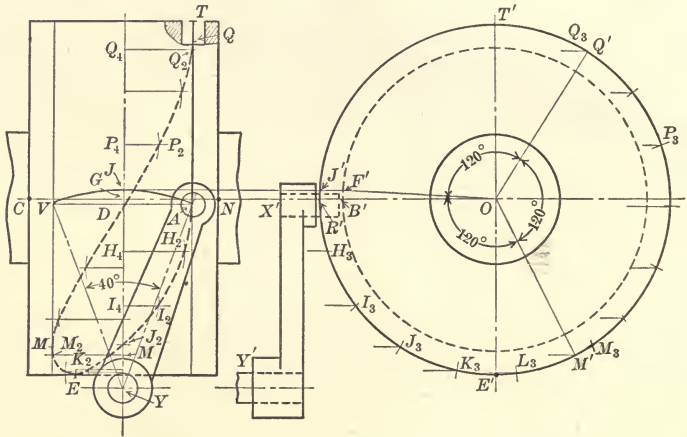

FIG. 61.—CYLINDRICAL CAM WITH SWINGING FOLLOWER DRAWN FROM CHART

from Fig. 60. To find the point of tangency at E , make $K_4 E_1$ of Fig. 60 equal to $K_3 E'$ of Fig. 61, then draw $E_1 E$ in Fig. 60 and lay off this distance from the center line $G Y$ in Fig. 61, thus giving the point E . To find the point of tangency at M , lay off at $M' M_3$ a distance equal to the chart distance from M_2 to M in Fig. 60 and project M_3 of Fig. 61 to M .

SECTION IV.—TIMING AND INTERFERENCE OF CAMS

141. In machines where two or more cams are employed it is generally necessary to lay down a preliminary diagram showing the relative times of starting and stopping of the several cams, in order to be assured that the various operations will take place in proper sequence and at proper intervals. The same preliminary diagram is also used to avoid interference and to make clearance allowances for follower rods whose paths cross each other.

142. PROBLEM 17. CAM TIMING AND INTERFERENCE. Required two cams that will operate the follower rods *A* and *E*, Fig. 62, lying in the same plane, so that:

(a) Rod *A* shall move 16 units to *D*, dwell for 30° , return 8 units to *B* and again dwell 30° , all to take place in 180° turn of the cam. The cam to produce the same motions in the second 180° but in reverse order.

(b) Rod *E* shall cross path of rod *A* and move 4 units beyond it and back again during the time that rod *A* is moving from *D* to *B* to *D*.

All motions to be on the crank curve with maximum pressure angles of 40° .

143. Before taking up the solution of this problem in detail it should be noted: 1st, that any convenient type of cam may be used in problems of this kind;

2d, that usually only general motions of followers or objects are given in the preliminary data, as above, and that the cam designer must supply data and restate the problem in terms of angles for each of the movements after studying the preliminary data with the aid of a timing diagram.

144. The first step leading to a restatement of the problem is to determine the number of degrees in which rod *A* may move the

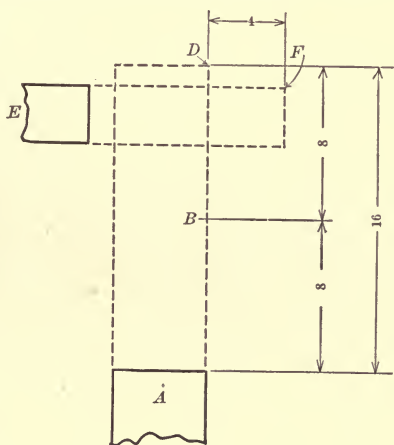

FIG. 62.—PROBLEM 17, PRELIMINARY LAYOUT OF DATA FOR PROBLEM IN CAM INTERFERENCE

16 units, and also the number of degrees in which it may move the 8 units in order that the pressure angle will be 40° in both cases. Since there are two 30° dwells in the first 180° there will be 120° left for the two motions of which the first motion will require $\frac{16}{24}$ of 120° or 80° , and the second, 40° . The length of chart for cam A may now be computed as $16 \times 1.87 \times \frac{360}{80} = 134.6$ and laid off as at $A A_1$, Fig. 63. The height of the chart $A D$ is 16 units. The chart is next divided into degrees of any convenient unit, $0, 10^\circ, 20^\circ \dots$ being used in this case. For the present the base line may be made up of a series of straight lines as at $A D_1, D_1 D_2, D_2 B_1 \dots$

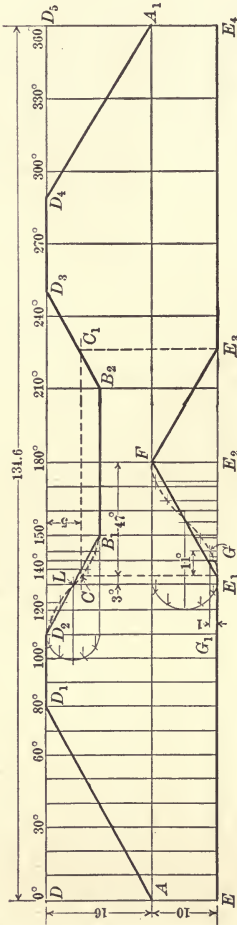

FIG. 63.—PROBLEM 17,
TIMING DIAGRAM FOR
AVOIDING INTERFER-
ENCE OF CAMS

145. The amount of clearance between the moving arms must now be decided upon. Let it be the designer's judgment that the end of the follower rod E should lie at rest 1 unit to the left of rod A as shown in Fig. 64, and that rod E should not begin to move until the rod A is one unit out of the way. Then A will be at C , Fig. 64, moving down, when E starts, assuming the rod E to be 3 units wide and that it is so placed that its top edge is one unit below D . The point C is then 5 units from the top of the stroke and if this distance is laid off in Fig. 63, as shown, the line $C C_1$ is obtained cutting the crank curve, which should now be drawn at C . C is at the 133° point and this, then, is the time when the follower E should start to move.

146. The total motion for rod E is $4 + 5 + 1 = 10$ units, assuming width of rod A to be 5 units. The time during which this motion can take place, outward, is $180^\circ - 133^\circ = 47^\circ$ as represented at $E_1 E_2$, Fig. 63. If the crank curve $E_1 F$ is now drawn it will be intersected by the one-unit clearance line $G_1 G$ at G which represents, in this case, a rotation of approximately 11° of the cam that drives rod E . The total clearance for the two rods which cross each

other's paths is now found to be 3° for cam follower *A* and 11° for cam follower *E*, or 14° of the machine cycle. These clearances are indicated in Fig. 63. If it is the judgment of the designer that errors in cutting keyways and in assembling, and that the wear of the parts will fall within these limits, the cams may now be drawn.

147. The cam chart for cam *E* was made the same length as

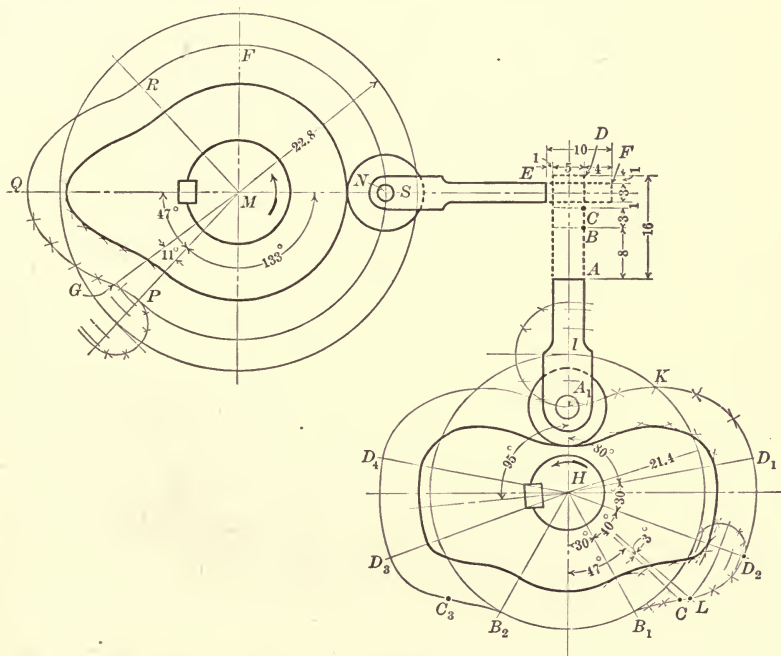

FIG. 64.—PROBLEM 17, DESIGN FOR DEFINITE TIMING AND NON-INTERFERENCE OF CAMS OPERATING IN SAME PLANE

the chart for cam *A* in order to make clearance allowance. The true length of this chart, for a 40° pressure angle, would be:

$$10 \times 1.87 \times \frac{360}{47} = 143.2 \text{ units,}$$

instead of 134.6 as now drawn. If an exact clearance allowance in degrees were required, it would be necessary to redraw the crank curve E_1F , making the distance E_1E_2 equal to $\frac{47}{360}$ of 143.2. It is now $\frac{47}{360}$ of 134.6. With a new and exact drawing the crank curve E_1G

would not rise quite so rapidly and the intercept at G would show a small fraction over the 11° taken above. In some problems where the lengths of the true charts differ considerably it may be necessary to redraw this part of the base curve to be sufficiently accurate in obtaining the clearance in degrees.

148. The radius of the pitch circle for the cam operating rod A will be $\frac{134.6}{6.28} = 21.4$ units as drawn at HI , Fig. 64. The pitch surface of the cam and the working surface are drawn in the same way as the ordinary radial cams in previous problems. The length of the rod A_1A may be assumed.

The radius for the pitch circle for the cam operating rod E will be $\frac{143.2}{6.28} = 22.8$ and this is laid off at MS . The location of M and the length of the rod NE will either enter into the layout of the framework of the machine in a practical problem, or will be determined

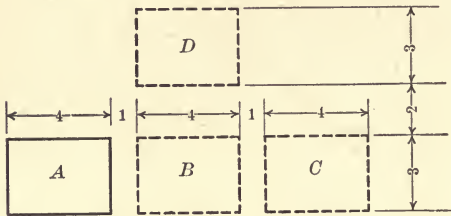

FIG. 65.—PROBLEM 17a, DIAGRAM SHOWING APPLICATION OF DATA

by the framework if previously laid out. In the present case it will only be necessary, in determining the length of rod NE and the position of M , to make certain that the shafts M and H are sufficiently far apart to keep the cams from striking when turning.

149. LOCATION OF KEYWAYS. It is important to locate the keyway exactly by giving its position in degrees so as not to destroy the clearance values already made. Since the working surfaces of cams frequently approach close to the hub or shaft it is a good plan to place the keyway at the center of the longest lobe of the cam, as illustrated in both cams.

150. EXERCISE PROBLEM 17a. Assume a stack of blocks at A , Fig. 65. Required that the bottom block shall be delivered with one stroke at C , the next block at D , being moved first to B and then to D , the next block at C , the next at D , etc. Let the sizes of the blocks and the distances they must be moved be as shown in Fig. 65. Lay out cam mechanism to secure this result, keeping the maximum pressure angle at 30° .

SECTION V.—CAMS FOR REPRODUCING GIVEN CURVES OR FIGURES

151. PROBLEM 18. CAM MECHANISM FOR DRAWING AN ELLIPSE. Required a cam mechanism that will reproduce the ellipse $A C B D$ in Fig. 66, the marking point to move slowly at the extremities A and B of the major axis and rapidly at C and D , the rate of increase and decrease of velocity being uniform.

152. Divide $A C$ into three parts which are to each other as 1, 3, and 5; $C B$ into three parts which are as 5, 3, and 1 . . . in order that the marking point shall move through increasing spaces in equal times in moving from A to C For greater accuracy $A C$ would be divided into a greater number of parts.

153. In devising the mechanism assume that the marking point shall be at the end of a rod which shall be controlled by two component motions that are horizontal and vertical, or nearly so. This suggests the rod $A E F$, with marking point at A , with horizontal motion supplied from a bent rocker attached at F and with vertical motion supplied from a reversing straight arm rocker $L K J$, attached through a link $E J$ at the point E . The lengths of the links and of the arms of the rockers, and the positions of the fixed centers of the rockers will have to be assumed, the lengths of the arms and links being such that none of them will have to swing through more than 60° . With more than 60° swing the angle between an arm and a link is liable to become too acute for smooth running. Where rocker arms are connected to links the ends of the rocker should, in general, swing equal distances above and below the center line of the link's motion, as for example, the points F and 6 on the arc of swing of F should be as much above the line $A M$ as the point 3 is below. Also the arc $3 J 9$ should swing equally on each side of $J T$ in order to secure best average pressure angles for the mechanism.

154. Let each of the rocker arms be assumed to be controlled by single-acting radial cams. The center of roller H will be required to swing on an arc $6 H$ which, continued, passes through M . This gives small pressure angles while A is traveling to B , especially when A is at C and is moving fastest. It gives large pressure angle, however, while A is traveling from B to D to A . If A is assumed to do heavy work along $A C B$ and to run light along $B D A$ this is the

better arrangement. If A did the same work on both strokes it would be better to place the rocker arm GH so that H and δ rested on a radial line. The center of roller L will be assumed to travel on an arc whose extremities are on a radial line, or nearly so.

With AF as a radius and $A, 1, 2 \dots$ as centers, strike short arcs intersecting $F\delta$ at $F, 1, 2 \dots$ numbering the arcs as soon as drawn to avoid confusion later on. Lay off points on $H\delta$ corresponding to those on $F\delta$.

155. Inasmuch as the point H does not move in accordance with the law of any of the base curves no precise computation can be made for the size of the pitch circle for any given pressure angle and it may be omitted. Instead, a minimum radius MH of the pitch surface may be assumed. If it is desired to control the pressure angles it may be done by first constructing the pitch surface, $H\delta W$, and then measuring the angles at the construction points. Some of these are shown in Fig. 66, at $H, 3, \delta$, and 8 , and are 20° , -12° , 48° , and 57° , respectively. If these angles should prove unsatisfactory a larger pitch circle, or a differently proportioned rocker, may be used. Or, an approximate computation for radius of pitch circle by the method which is explained to advantage in connection with the next problem, paragraphs 164 and 165, may be used.

156. To construct the second cam, take the distance AE as a radius and $A, 1, 2 \dots$ as centers and mark the points $E, 1, 2 \dots$. Again, with the latter points as centers and EJ as a radius, mark the points $J, 1, 2 \dots$ and transfer these to $L, 1, 2 \dots$. With the latter points marked, the pitch surface of the second cam, PQR , is constructed in the same way as was the first cam.

The angle between the keyways, marked $39\frac{1}{2}^\circ$ in Fig. 66, must be carefully measured and shown on the drawing.

157. EXERCISE PROBLEM 18a. Required a cam mechanism that will draw the numeral 8, the marking point moving with uniform velocity.

158. PROBLEM 19. CAMS FOR REPRODUCTION OF HANDWRITING. Required a cam mechanism to reproduce the script letters *St e*.

159. The first step in the solution of this problem is to write the letters carefully, for if the machine is properly designed it will reproduce the copy exactly as written. The copy is written at **A** in Fig. 67.

160. The next step is to decide on the kind of mechanism and the type of cams to be used, for the problem may be solved by a number of different combinations. The mechanism for this problem

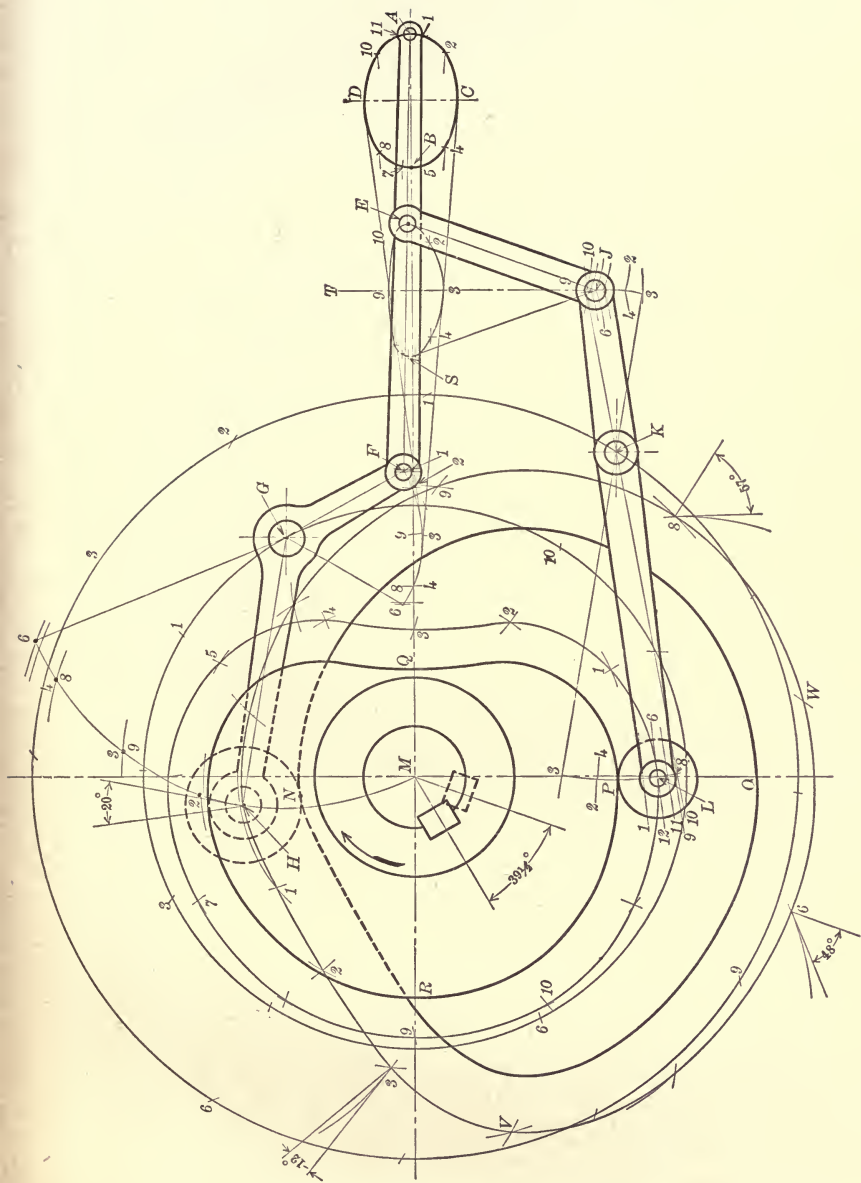

FIG. 66.—PROBLEM 18, CAM FOR DRAWING AN ELLIPSE

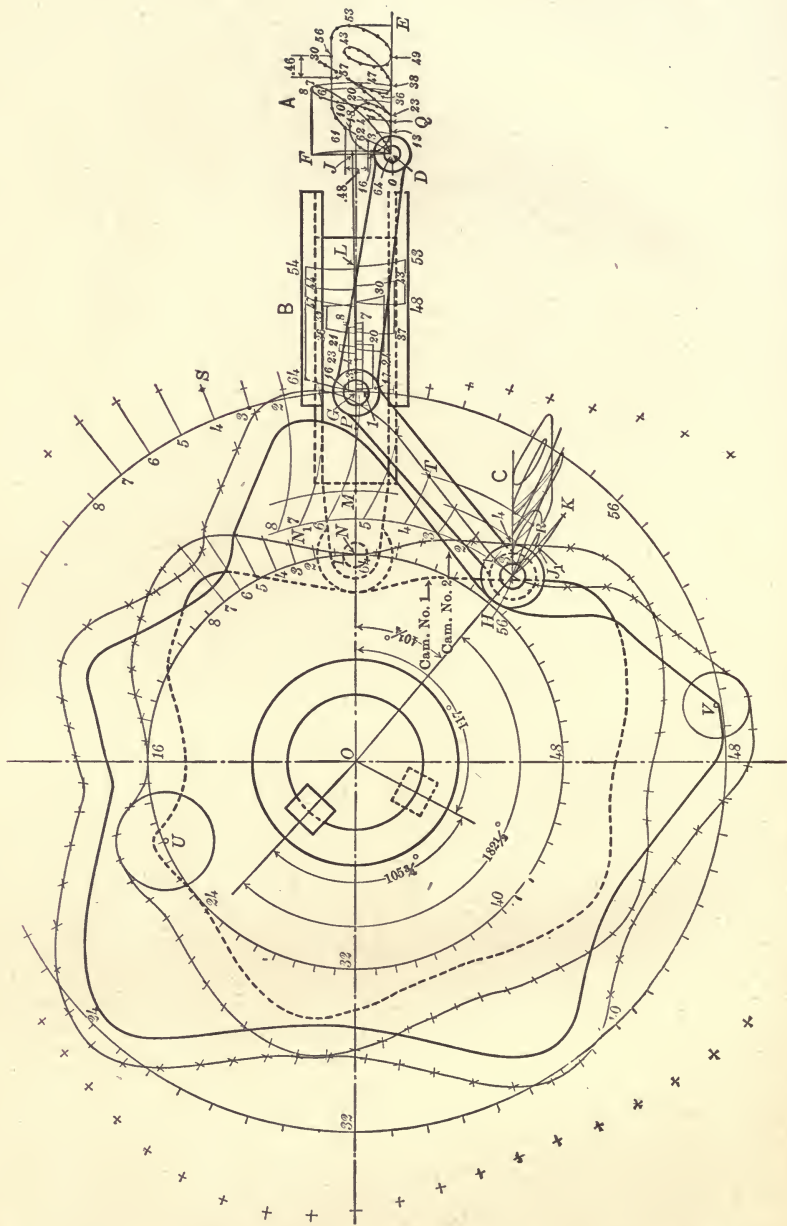

FIG. 67.—PROBLEM 19, CAMS FOR REPRODUCING SCRIPT LETTERS, ETC.

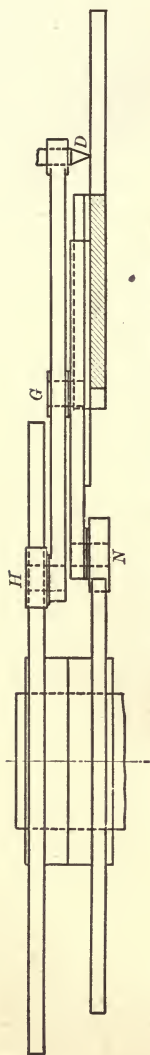

FIG. 68.—PROBLEM 19, FRONT VIEW OF CAM MECHANISM

will consist of two radial single-acting cams mounted on one shaft, and a swinging rocker arm mounted on a pivot which is moved forth and back on a radial line as shown in Fig. 67. This mechanical combination is selected for this problem because it involves methods of construction not used in any of the preceding problems.

161. The actual work of construction is started by marking off a series of dots along the lines of the entire copy, as shown at **A**, and marked from zero to 64. Inasmuch as there is some latitude in the spacing, and consequently in the number of these dots, as will be explained presently, it is advisable to use a total number of dots whose least factors are 2 and 2, 2 and 3, or 2 and 5. This is not essential but it will facilitate the work later on.

162. The matter of placing the dots is perhaps the most important item of the entire problem, for on this depends the size of the roller and smooth action. In fact, with some methods of spacing, no roller can be used at all and a sharp V-edge sliding follower will have to be used if true reproduction is desired.

The basic considerations in selecting the points are:

First, that a point should be located at the extreme right and extreme left of each right and left throw, as at $0 - 7, 7 - 16, 16 - 20 \dots$ in Fig. 67, **A**, and at the top and bottom of each swing, as at $0 - 8, 8 - 13, 13 - 18 \dots$; and,

Secondly, that the marking point should start slowly and come to rest gradually on each stroke, considering both of the component directions of its motion at the same time. On account of this

it is impossible to secure ideal conditions at all times and compromises must frequently be made. For example, the component motions of the marking point **D** are: First, a horizontal one due to Cam No. 1; and secondly, a vertical curvilinear one due to Cam No. 2 and the rocker arm **HGD**. The intermediate points $0-7$ on the upper swing of the letter **S** are so selected as to give increasing and

decreasing spaces in the horizontal projections on DE , and the same points, together with point S , are selected at the same time so as to give increasing and decreasing spaces when projected onto the arc DF . Each space between a pair of adjacent numbers represents the same time unit. On this basis the entire spacing of the copy is done.

163. With each of the points in the group at **A**, Fig. 67, as centers, and with a radius, DG , mark very carefully the corresponding points on GL in group **B**. To avoid confusion it is essential here to adopt some method of identifying points so marked for later reference. A satisfactory method is shown at **B**, all the motions to the right being indicated below, and the motions to the left, above GL .

164. The sizes of the cams are to be next computed. To do this select the largest horizontal space in section **A**. This is found between 56 and 57 and is equal to $.46$ of the unit of length that happened to be selected in this problem. Assuming that the marking point moves with uniform velocity over this distance, and that a pressure angle of 40° is suitable in this instance where no heavy work is done, the factor of 1.19 is taken from the table in paragraph 30. Since there are 64 time units the length of circumference of pitch circle for Cam No. 1 will be

$$.46 \times 1.19 \times 64 = 35.03, \text{ and the radius } 5.58.$$

165. Before calculating the size of Cam No. 2 the length of the rocker arm GH must be decided upon and this will be taken in this problem at 5 units, the same as the arm GD . Then the total swing of the follower point H will be HK , equal to DF , and the greatest swing in any one direction in any one time unit will be during the periods $10-11$ and $61-62$, shown at **A**, Fig. 67, both equal to $.48$ units. Making the same computation as for Cam No. 1,

$$\frac{.48 \times 1.19 \times 64}{3.14 \times 2} = 5.82$$

equals the pitch radius of Cam No. 2.

166. The position of the cam shaft O relatively to the pivot arm G depends on what is desired for the position of the arc HK with reference to the cam center. If it is desired that the points H and K shall be on a radial line from the center of the cam, which gives best practical average results for both in and out strokes, proceed as follows: Draw chord DF at **A** in Fig. 67; bisect it at J and measure distance GJ which is 4.93 units. Then the distance

GO will be the hypotenuse of a right angle triangle of which one side is 4.93 and the other 5.82. This may be separately drawn and the length of the hypotenuse found graphically or it may be figured as follows:

$$GO = \sqrt{5.82^2 + 4.93^2} = 7.63.$$

167. The pitch circles for both cams may be taken in problems of this kind to pass through the midpoint of the total travel. Then OM is the radius of the pitch circle of Cam No. 1 and NP the total range of travel of the roller center; and OJ_1 is the radius of the pitch circle of Cam No. 2 and HK the total range of travel of the roller center relatively to G .

168. To find points on the pitch surface of the cams proceed in the usual way for Cam No. 1, by dividing the circle whose radius is ON into as many equal parts as there were dots on construction points at **A**. Draw radial lines, and on these lay off the distances secured from **B** in Fig. 67; for example, the distance $3N_1$ is laid out equal to $G3$. The point N_1 , and other points secured in similar manner, will lie on the pitch surface of Cam No. 1.

169. The construction of the pitch surface for Cam No. 2 is different from that of Cam No. 1, and is different also from anything done in the preceding problems. In this case the resultant motion of the arm GH is made up of rectilinear translation and rotation and both components must be considered in laying out the pitch surface, for example, as follows: With GH as a radius and point 4 of **B** as a center draw an arc intersecting the horizontal line through H at 4. Then when G is moved to 4 by Cam No. 1, H would be at 4 if the rectilinear component motion due to cam No. 1 were the only one acting. During the period represented by $G4$, however, Cam No. 2 must move the rocker arm through an arc $Q4$, shown at **A**, and this arc must now be laid off at 4 R . The point R is then revolved to its proper position at T as follows: Divide the circle OG into sixty-four equal parts. This is readily done in this problem because G is taken on the same radial line with N and the radial divisions already made on the circle having ON for a radius need only be extended. Lay off the distance $G4$ at 4 S . With S as a center and GH as a radius draw the arc 4 T . Then T will be a point on the pitch surface of Cam No. 2.

170. Having determined the pitch surfaces of the two cams the largest possible roller for each is found by searching for the shortest radius of curvature on the working side of each pitch surface. For

from F to the next step beyond B . Assume that there are 11 steps from F to G , then go forward 11 steps on the arc to K . Divide the large part of the circle KDB into eighty parts by the process of subdivision with the dividers as indicated by the divided angles 80, 40, 20, 4, 2, and 1, in Fig. 69. Then BH is $\frac{1}{80}$ of KDB , or $\frac{1}{87}$ of the entire circle, and the length BH will go exactly seven times into the arc BK . In this work nothing is said of the use of a protractor for laying off a large number of small subdivisions on a circle, although it may be used. The process of subdivision, however, always using the small dividers, gives automatically remarkably accurate results.

INDEX

A	PAGE		PAGE
Acceleration given by different base curves.....	20-24	Dog cam.....	11
Adjustable cams.....	11	Double acting cams.....	9
Angle in pitch surface of cam, effect of.....	37	Double disk yoke cam.....	65
Automatic work, cams for.....	75	Double end cam.....	7
		Double step cam.....	39
		Drum cam.....	7
B		E	
Barrel cam.....	7	Elliptical base curve.....	15, 23
Base curve.....	14	Empirical design.....	25
Base curves charted.....	15	End cam.....	7
Base curves, method of construction	20	Exercise problems 1a to 18a.....	31-80
Base line.....	14		
Box cam.....	8	F	
		Face cams.....	3, 55
C		Factors for pressure angles.....	17, 18
Cam chart.....	12, 29	Flat surface followers, limited use of.....	49, 59
Cam chart diagram.....	12	Flat surface reciprocating follower	45
Cam chart, omission of.....	31	Follower roller, limiting size of	35
Cam considered as bent chart.....	34	Frog cam.....	3
Cam defined.....	1		
Cam factors.....	17	G	
Carrier cam.....	11	Groove cam.....	3
Chart showing cam factors.....	18		
Clamp cam.....	11	H	
Classification of cams.....	1, 12	Heart cams.....	3
"Combination curve," straight line.....	15, 20, 56	Handwriting, cams for reproducing	80
Conical cams.....	2, 11		
Crank curve.....	15, 21	I	
Cylindrical cam design, refinements in.....	69	Interference of cams.....	75
Cylindrical cam, straight moving follower.....	68	Internal cam.....	8
Cylindrical cam, swinging follower	70		
		L	
D		Limited application of single disk yoke cam.....	64
Diagram, cam chart.....	12	Limited size of roller.....	35
Diagram, timing.....	13, 14, 76	Limited use of flat surface fol- lower.....	49, 59
Disk cams.....	1		

	PAGE		PAGE
Location of chart pitch line for double-step cams.....	39	Radial cams.....	1
Location of swinging follower arms	53	Radius of curvature of non-circular arcs.....	38
M		Reproduction of curves and figures by cams.....	79
Maximum pressure angle.....	17	Roller, limiting size of.....	35
Maximum pressure angles for mul- tiple-step cams.....	41	Rollers, for positive-drive cams....	37
Multiple-mounted cams.....	11	Rolling cams.....	5
Mushroom cams.....	3, 45	S	
N		Side cams.....	1
Names of base curves.....	14	Single-acting cams.....	9
Names of cams.....	2	Size of roller for cams.....	35
Non-circular arcs, radius of cur- vature of.....	38	Step cams.....	9
O		Straight-line base.....	15, 20
Offset cam.....	8	Straight-line combination curve	15, 20, 56
Offset flat face follower.....	45	Strap cams.....	11
Offset follower roller.....	42	Subdividing circles and arcs.....	86
Omission of cam chart.....	31	Swinging follower arms, effect of	
Oscillating cams.....	11	flat surface contact.....	57
P		location of.....	53
Parabola base curve.....	15, 22	roller contact.....	50-56
Periphery cam.....	2	T	
Pitch circle.....	15	Technical design.....	27
Pitch line.....	15	Time charts.....	13, 14, 76
Pitch line for double-step cam....	39	Timing of cams.....	75
Pitch point.....	16	Toe and wiper cams.....	7, 61
Pitch surface.....	15	V	
Plate cams.....	3	Velocities given by different base curves.....	20-24
Plate groove cams.....	3	W	
Positive drive cam.....	8, 55	Wiper cam.....	5, 61
Pressure angle.....	17	Working surface.....	16
change in passing from chart		Y	
to cam.....	33	Yoke cam.....	5
depends on size of pitch circle	33	double-disk.....	65
for flat face follower.....	48	single-disk.....	63
for offset follower roller.....	43		
for swinging follower arms..	50		
in multiple-step cams.....	41		
unequal on the two strokes...	31		
Problems 1 to 18.....	25-79		

THIS BOOK IS DUE ON THE LAST DATE
STAMPED BELOW

AN INITIAL FINE OF 25 CENTS
WILL BE ASSESSED FOR FAILURE TO RETURN
THIS BOOK ON THE DATE DUE. THE PENALTY
WILL INCREASE TO 50 CENTS ON THE FOURTH
DAY AND TO \$1.00 ON THE SEVENTH DAY
OVERDUE.

APR 13 1941

APR 14 1941

FEB 13 1948

APR 21 1948

17 Mar '50 EH

31 Jan '52 JK

17 Jan '52 Lii

YC 12794

349326

Jurman

TJ 206
F8

UNIVERSITY OF CALIFORNIA LIBRARY

