

TJ
176
P3

UC-NRLF



B 3 141 185

ENGIN.
LIBRARY

ELEMENTARY
DRAWING SHOP PRACTICE

PARSONS

YB 24122

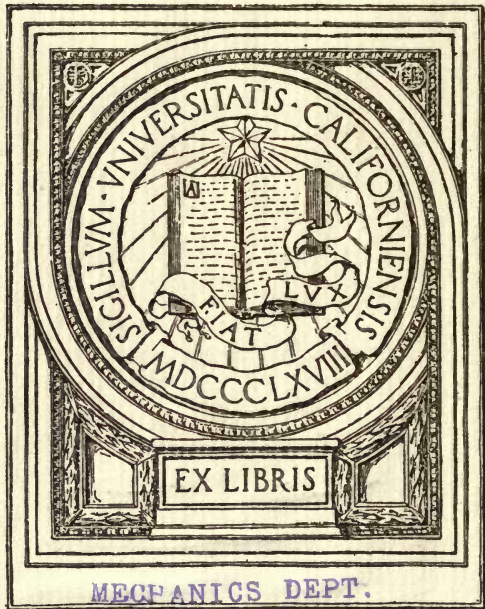

Engineering
Library

ELEMENTARY
MACHINE SHOP PRACTICE
CALIFORNIA

AS ADAPTED TO ITS TEACHING IN
TECHNICAL SCHOOLS

By T. J. PALMATEER
INSTRUCTOR IN MACHINE WORK
Leland Stanford Junior University

Copyright 1918 by T. J. PALMATEER

1918

Stanford University Press

TJ1160

P.3

Engineering
Library

UNIVERSITY OF CALIFORNIA
MACHINERY PRACTICE
CALIFORNIA

UNIVERSITY OF CALIFORNIA
TECHNICAL SCHOOLS

MECHANICS DEPT.

UNIVERSITY OF CALIFORNIA
TECHNICAL SCHOOLS

UNIVERSITY OF CALIFORNIA

1918

UNIVERSITY OF CALIFORNIA

PREFACE

The instructions given in this book should meet the requirements of beginners in general machine shop practice. The main object is to reduce as much as possible the time required to bring a student with no previous shop experience to the point where he is able to do some real work. The instructions given refer mainly to the cutting of metal, since this usually gives the most trouble to beginners. Little attempt has been made to describe the mechanism of the different machines because it varies so much with the type and make and is besides easily understood by the average student.

To obtain the best results with this book the following procedure is suggested. In most cases it can be carried out without seriously interfering with the previously established work of the school:

1. The instructor should give practical demonstrations for the different exercises and actually perform those operations which he considers necessary.

2. The student should study the instructions given herein during his leisure time before and after the demonstration.

3. Each student should have a book for use in the shop so that it may be consulted whenever necessary. This will help to develop initiative.

4. A certain amount of time should be allowed to complete the work. This should be enough to enable the average student to finish on time.

Many thanks are due to H. P. Miller, Jr., for his helpful assistance in the preparation of this book and to the following manufacturers for the half-tone illustrations: Smith & Mills Co., Sibley Machine Co., and the Cincinnati Milling Machine Co.

T. J. PALMATEER.

Stanford University, Cal.

February, 1918.

PART I.

LATHE WORK

PART I

THE WORK

EXERCISE No. 1

FIT SHAFT TO COLLAR—RUNNING FIT

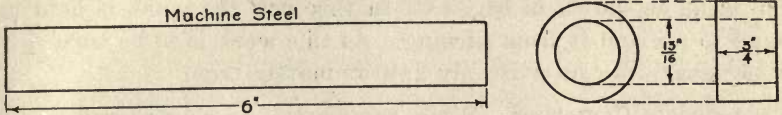

Cut off with a power hack-saw a piece of steel $6 \frac{1}{16}$ inches long from a bar 1 inch in diameter. This will allow $\frac{1}{16}$ of an inch for finishing the ends and $\frac{3}{16}$ of an inch for turning the diameter.

An experienced lathe operator would use a piece of steel $\frac{7}{8}$ of an inch in diameter, but for beginners it is better to use larger stock to allow for practice turning.

CENTERING

Center both ends in the centering machine. The size of the center in this shaft should be be from $\frac{3}{16}$ to $\frac{1}{4}$ of an inch in diameter. Larger work should have deeper centers.

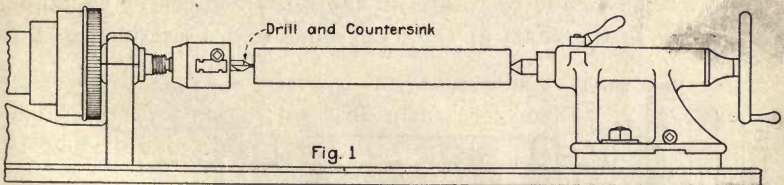

Fig. 1

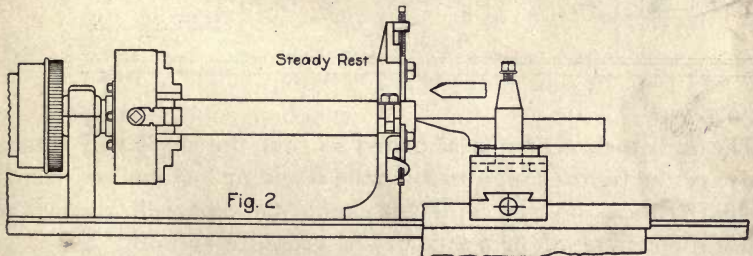

Fig. 2

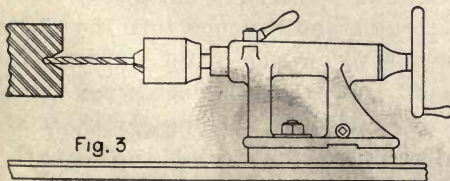

Fig. 3

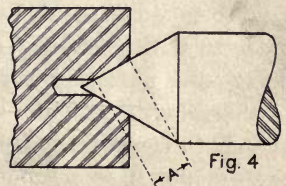

Fig. 4

If a centering machine is not available, the work may be centered by first locating the center with a pair of dividers and center punch and then using a combination drill and countersink in the lathe as shown in Fig. 1. In this case the work is held by hand to prevent it from turning. As this work is to be turned, it is necessary to center it only approximately true.

Accurate Centering.--When the work is to be centered accurately, it may be done by putting one end in the lathe chuck and the other in a steady rest. A pointed tool is then used in the tool post as shown in Fig. 2. The point of this tool has an angle of 60 degrees, the same as the lathe centers, and is ground like a flat drill so that it cuts on both sides.

After the shaft is centered with this tool, a center hole about $1/8$ of an inch in diameter should be drilled. This is done by holding the drill in the tail-stock of the lathe with a drill-chuck, as shown in Fig. 3. The object of this center hole is to give the center of the shaft a bearing on the lathe center a short distance back from the point, as at A in Fig. 4.

PLACING WORK IN LATHE

The work is made to rotate on the lathe centers by fastening a lathe dog to the shaft at the head-stock end, as shown at A in

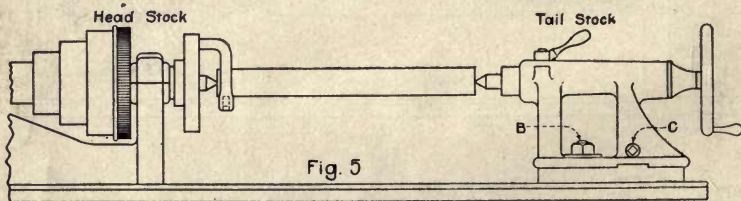

Fig. 5.

The tail-stock center is adjusted so that the shaft will rotate freely, yet be tight enough to allow no slack, or lost motion. Since the shaft rotates on this center, it should be kept well lubricated by using machine oil, or a mixture of graphite and oil.

To get the best results in turning this sort of work, it is necessary to face both ends before turning and to rough turn the whole piece to within about 0.03, or 0.04 of an inch of the finished size before any part of it is finished. However, it is not always necessary to do this. The object of first rough turning the shaft all over is to remove the internal strains of the steel and to wear the centers down to a good bearing before any finishing cuts are

taken. The purpose of facing the ends is to get them square, or true, and smooth.

FINISHING END OF SHAFT

To face the ends, use a regular turning tool starting to cut from the outside and feeding by hand towards the center with the cross feed. Such a tool will leave a ridge near the center, as shown in Fig. 6. This ridge is cut off with a sharp pointed, side cutting tool, as shown in Fig. 7, which is also used for taking the

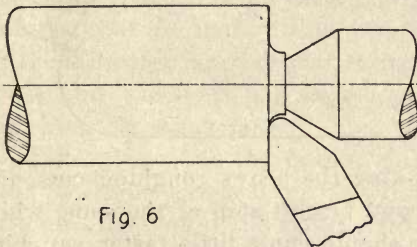

Fig. 6

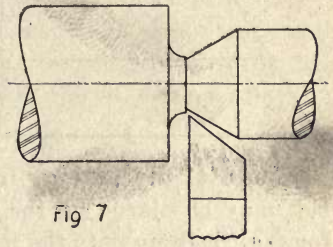

Fig. 7

finishing cut across the whole end of the bar. When taking this finishing cut, lard oil, or some other lubricant, should be used.

After the finishing cut has been taken, any small ridge, or fin that remains at the edge of the center is removed by slightly changing the angle of the tool in the tool post and allowing about $1/64$ of an inch play between the centers. Having the work loose like this when the lathe is running, allows the extreme point of the side tool to extend beyond the edge of the center and cut a smooth end.

The lathe should run slow for the finishing cut and fast when the regular turning tool is used.

TURNING THE SHAFT

The first, or roughing cut, is taken with a high speed steel tool, or bit, fastened in a tool holder. The tool holder is clamped in the tool post of the lathe so that the point of the tool is at, or a little above, the center, or axis, of the lathe, as in Fig. 8.

If the point of the bit is too high, it is easy to see that, as the shaft rotates, the tool will not cut at all. Fig. 9. In case the tool is set below the center, the cutting action is very poor so that turning tools are never set as in Fig. 10.

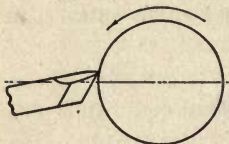

Fig. 8

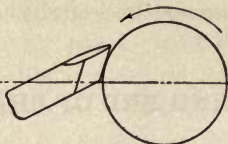

Fig. 9

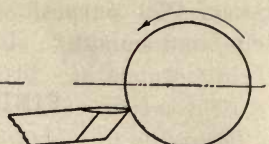
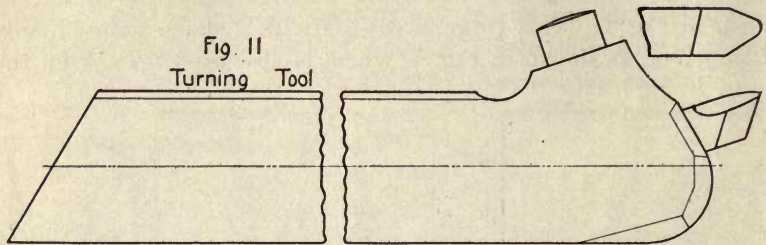

Fig. 10

Fig. 11
Turning Tool

Speed of the Lathe.—In taking the heavy roughing cuts, the belt may be placed on the second largest step of the cone, while for the finishing cuts the lathe should run a little faster, say with the belt in the next smaller step.

Grinding Turning Tool.—The front, or point, and the sides of the tool are ground at an angle, which is called the clearance. If the tool has too little clearance, it will not cut freely, while if it has too much clearance, the point will be so thin that it will break off or become dull quickly.

The top of the tool is also ground at an angle. This is called the rake. If the tool has too little rake, it will not cut freely and if it has too much, the edge will soon break down.

It requires some practice for a beginner to learn the proper rake and clearance that should be given to a tool. Fig. 11 shows a tool ground with clearance and rake that will give very good results.

Direction Tool Should Travel.—The depth of the first cut should be about $1/16$ of an inch and the travel of the tool should always be from the tail-stock end towards the head-stock. If the travel is in the opposite direction, the pressure on the tail-stock center is increased, causing it to heat quickly.

The length of the cut should be as great as possible without the lathe dog striking the tool, or cross-rest.

Adjusting the Lathe to Turn Straight.—After the first cut, the work should be calipered and if it is not the same diameter

at both ends the tail-stock should be adjusted so that the lathe will turn straight.

The tail-stock adjustment is made by loosening the main clamping nut B and one of the screws C and then tightening the other screw C on the opposite side of the tail-stock, Fig. 5.

If the shaft is larger at the tail-stock end, the tail-stock should be moved towards the front of the lathe one half the difference between the diameters of the shaft at the two ends.

In doing close work, the tail-stock should be adjusted as closely as possible, but in this case if it is off center only a little, say 0.002 or 0.003 of an inch, it will be close enough providing it is set so that the shaft will be turned larger at the head-stock end. If the tail-stock is set so that the shaft is turned larger at the tail-stock end, the shaft will be too small at the other end after the finishing cut is taken.

Fitting Shaft to the Collar.—After the roughing cut is taken and the lathe has been adjusted so that it turns approximately straight, the end of the shaft is turned for about $\frac{1}{4}$ of an inch so that it will just fit the hole in the collar, shown in the drawing of Exercise 1. To measure this: first set the inside calipers to the diameter of the hole in the collar, then set the outside calipers to the inside calipers and caliper the shaft as accurately as possible. For a final test of this diameter, remove the work from the lathe and try it with the collar itself.

The advantage of turning but $\frac{1}{4}$ of an inch at the end of the shaft is this; if the finishing cut were set too deep, only $\frac{1}{4}$ of an inch of the shaft would be too small, while if this cut were taken the whole length, the entire shaft would be too small.

After the shaft has been turned at the end so that it fits the collar, the rest of the shaft should be turned a little larger, say 0.002 or 0.003 of an inch, in diameter. This will leave enough to finish with a file.

Filing.—The object of filing is to take out the tool marks, but it is also found to be much easier to make a close fit by filing off the last 0.002 or 0.003 of an inch than to take so small a cut with a tool. The amount of allowance for filing depends upon the character of the finishing cut. Since the less filing required the better, the finishing cut should be made as smooth as possible.

The tool used for the roughing cut may also be used for finishing, but it is usually necessary to re-sharpen it. After it is re-set in the tool post, the point should be flattened a little wider

than the pitch of the feed, say about $1/32$ of an inch, and parallel with the work. This is done with an oilstone.

For filing work on a lathe, a single cut file is used. This is called a lathe, or mill file.

The stroke of the file should be slow, steady, and straight across the shaft. The lathe should run a little faster for filing than for turning, the object being to have the work make several revolutions for a single stroke of the file. If the lathe runs too slow and the stroke of the file is too fast, the shaft, instead of being filed round, will have a series of flat places on the surface.

After the work is finished as close to the dog as possible, reverse it in the lathe and finish that part where the dog was fastened.

EXERCISE No. 2.

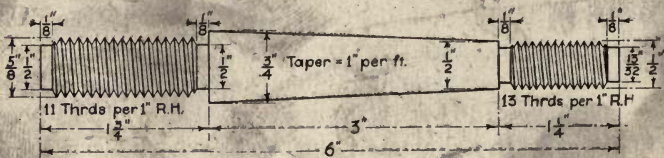

The finished shaft in Exercise No. 1 may be used for Exercise No. 2.

Place the shaft in the bench vise and with a rule and scriber lay off the dimensions: $1\frac{3}{4}$ in., 3 in., and $1\frac{1}{4}$ in. Then center punch the lines just deep enough so that they can be easily seen when the work is in the lathe.

Turn the large end first.

When it is necessary to turn a fixed distance, or to a line as in this case, it is well to disconnect the feed when the tool is within about $1/8$ of an inch from the end of the cut and to feed the tool the rest of the distance by hand. If this is not done, the tool may travel farther than it is intended to.

It is better to turn the portions to be threaded a little under rather than over size. For if they are over size, the threads will not fit the standard size nut, but if under size the threads do not need to be cut so deep in order to fit the nut.

For measuring the diameters of this piece set the calipers as

accurately as possible by measuring from the end of the rule, as shown in Fig. 12.

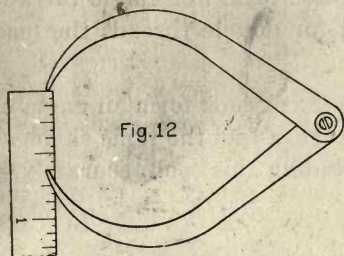

Fig. 12

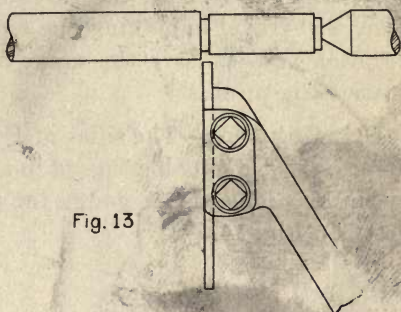

Fig. 13

Cutting Recess.—The surface at the end as well as the recesses between the threads and the taper are cut with a square-nose, or cutting-off tool, Fig. 13.

This tool should have a sharp smooth edge, the point being set level with the center of the lathe.

To produce a smooth finished surface lard oil should be used with a slow feed and lathe speed.

After the end is turned to size, reverse the work in the lathe and turn the other end and the taper before cutting the threads.

Turning Taper.—The drawing calls for a taper of 1 inch per foot. This is cut by using a taper attachment, or by setting the tail stock off center. As most lathes are not provided with a taper attachment, the latter method will be used.

If the work was 12 inches long, the tail stock would be moved off center $\frac{1}{2}$ inch to turn a taper of 1 inch per foot. It being only 6 inches long, the tail stock is set off center but half that amount, or $\frac{1}{4}$ inch.

Before taking the finishing cut, caliper both ends to prove that the lathe is cutting the correct taper.

THREAD CUTTING

The threads are cut to fit $\frac{1}{2}$ inch and $\frac{5}{8}$ inch nuts having United States Standard threads. These threads are flattened at the top and bottom to the amount of $\frac{1}{8}$ of the pitch instead of being sharp pointed as in the case of Standard V-threads.

Pitch.—The pitch of the thread is the distance from the center of one thread to the center of the one adjoining. On the end of the exercise having 13 threads per inch the pitch is $\frac{1}{13}$ of an inch so that the width of the flat at the top and bottom of this

thread should be $\frac{1}{8}$ of $\frac{1}{13}$ of an inch, or about .009 of an inch.

Lead.—The lead of the thread is the distance a nut on the screw will travel in making one complete turn. For single threads the pitch and lead are the same, but for double threads the lead is twice the pitch.

Grinding Tool.—The sides of U. S. S. threads form an angle of 60 degrees. To cut this thread in a lathe, a tool the same shape as the threads is used. A gauge for grinding this tool accurately is shown in Fig. 14.



Fig. 14

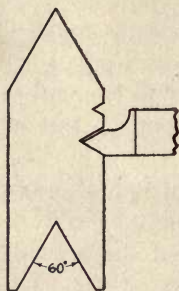

Fig. 15

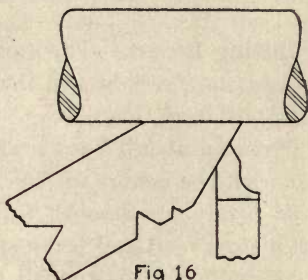

Fig. 16

If a U. S. S. thread gauge is not available, the tool can be ground with the aid of a regular thread and center gauge, shown in Fig. 15. With such a gauge the angle can be ground accurately, but it will be necessary to measure the flat point with a rule.

The top of the tool should be ground so that it will be approximately in a horizontal plane when set in the lathe.

Where the thread to be cut is as fine as 13 per inch the flat surface at the point of the tool is so small that the extreme point can be oil-stoned off instead of being taken off with the grinding wheel. The flat point should never be wider than the standard size, but if it is a little too narrow it will make very little difference in ordinary lathe work.

Setting Tool.—To set the tool so that both sides of the thread will have the same angle, the thread gauge is used as shown in Fig. 16. The tool should be set on a level with the center of the lathe.

How Lathe is Geared.—To cut 13 threads per inch the work must make 13 revolutions while the carriage, which carries the tool, travels one inch. For this purpose the lathe spindle is con-

nected to the lead screw with the proper size gears and the lead screw to the carriage by a split nut. This split nut is back of the carriage apron and is opened and closed by the lever E, Fig. 17.

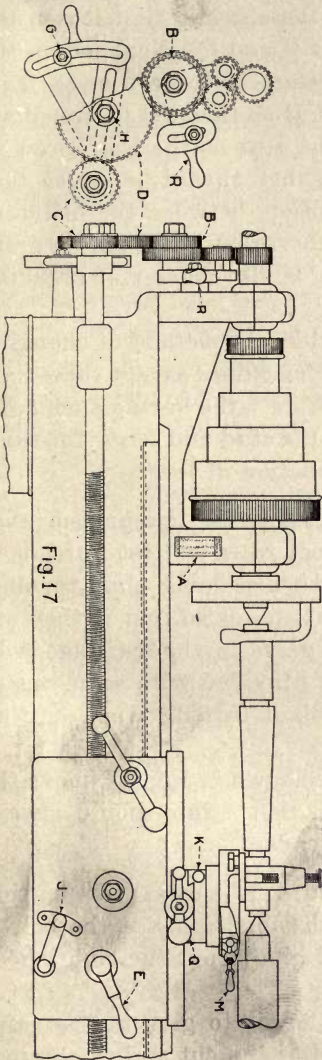

Fig. 17

- A. Index Plate
- B. Stud Gear
- C. Screw Gear
- D. Intermediate or Idle Gear
- E. Lever for connecting Carriage to Lead Screw
- J. Lever for Disconnecting and Reversing Feed
- K. Adjustable Stop for Thread Cutting

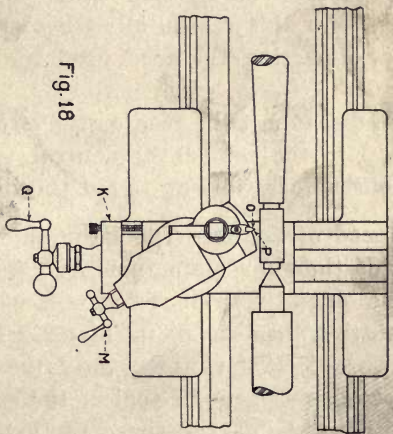

Fig. 18

If the lead screw of the lathe has 6 threads per inch, the gearing to cut 13 threads per inch must have the same ratio as 6 is to 13. To cut 16 threads the ratio would be 6 to 16.

It is not necessary to figure the size of gears for the different

threads as all lathes are provided with an index plate that designates the proper size gears to be placed on the stud B and screw C, Fig. 17, for the desired thread.

To Set Change Gear.—To change these gears, first loosen the nuts holding the stud and screw gears B and C. Next loosen the nut G. This will allow the intermediate gear to drop away from the stud gear B. Then loosen the nut H so that the intermediate gear can be drawn back away from the gear on the lead screw C.

When the gears are put together, they should be set so that there will be a little slack, or lost motion, between the different gears. If they are set too close together, they will make a great deal of noise when running and there is also danger of breaking the teeth.

While all lathes are not designed alike the method of changing the gears is very much the same on all machines except those having the quick change-gear device. With a lathe having such a device, instead of changing the gears on the stud and screw the same result is obtained by shifting a combination of levers.

Why Feed Should Be Disconnected.—The mechanism that controls the feed, or travel, of the tool when cutting threads is independent of that used for the feed when doing plain turning. The two feeds usually run at different speeds so that if they are both in action at the same time the gears in the carriage will break. For this reason all lathes are provided with some means of disconnecting the feed used for plain turning when cutting threads.

To disconnect the feed on the lathe shown in Fig. 17, move the lever J to the central, or neutral, position. This should always be done before starting to cut the threads.

Speed of Lathe.—The lathe should run slower for cutting threads than for plain turning. With most lathes if the belt is on the largest step of the cone it will give about the right speed for cutting the threads in this exercise.

The object of running the lathe slow is to give the operator time to draw back the tool at the end of the cut and to obtain a smoother cut. If the speed of the lathe is too fast, the cutting action will be so quick that the tool, instead of cutting clean and smooth, will tear out the metal leaving a rough surface.

The slower the lathe runs the easier it is to cut the threads, but it will also take longer to do the job. It therefore requires

practical experience to determine the proper speed to be used for cutting the different size threads.

Chamfering.—After the lathe and tool are properly set, chamfer off the sharp corners where the threads begin and end with the side of the thread tool. The depth of this cut should be about the same as that of the threads when finished. If the corners are not chamfered, the threads, when cut, will form a very thin edge, or fin, at the ends.

Use of Adjustable Stop.—To regulate the depth of each cut an adjustable stop is used as shown at K. First move the tool so that the point just touches the work, then adjust the screw on the attachment K so that the cross-rest will not go in any farther. Now move the carriage by hand until the point of the tool is a little past the tail-stock end of the work; close the split nut on the lead screw with the lever E; and turn the screw on the attachment K so that the tool can be moved in just enough to take a very light cut.

Start the lathe and when the tool has reached the end of the cut back it out and reverse the lathe. By reversing the lathe the tool is returned to the starting point without disconnecting any of the gearing. The object of drawing the tool back is to prevent it from dragging on the work during its return.

The tool will never travel over the same path on the reverse as on the forward movement of the lathe on account of the slack, or lost motion, in the gears.

This first cut is taken to prove that the lathe is properly geared, so the work should be measured with a rule, or screw pitch gauge.

Adjust the screw at K until the tool can be moved in deeper for the next cut and repeat the operation until the thread is nearly finished. Then the tool should be reset so that it will cut on only one side at a time.

Finishing Side of Thread.—When roughing out the threads, the tool cuts on both sides of the point since it is fed straight into the work. It is much easier, though, to finish the threads smooth if the tool cuts on one side only. This is done by rapping the end of the tool holder so that it is turned in the tool post just enough to change the position of the point of the tool about .01, or .02 of an inch.

To prove that the tool is set over the proper amount, turn the

lathe forward by hand a few revolutions, to take out all the slack, or lost, motion in the gears, then move the tool into the groove of the thread until one side just touches the side of the thread. The other side of the tool should then be about .01, or .02 of an inch away from the side of the thread.

After the tool is properly adjusted, set the stop K. The tool is then drawn back and the lathe reversed until the tool is at the end of the work ready for a cut. It usually requires several finishing cuts to take out all the rough marks left by the roughing cuts.

When this side of the thread is finished, the other side is finished in the same manner.

If the lathe is provided with a compound rest, a somewhat different procedure is usually followed since the rest can be set at an angle of 30 degrees with the work, as in Fig. 18.

In this case the tool is moved in by turning the small hand-crank M until the side at O has been cut to the proper depth. While making these first cuts, the stop K is merely used to bring the cross-rest to the same position each time. The tool is then drawn back slightly with the hand-crank M and the stop K adjusted so that the tool can be moved straight in by means of the hand-crank Q. This will finish the other side of the thread at P.

To determine when the thread is cut to the proper size the work is removed from the lathe and tested with a standard nut having U. S. S. threads.

After the threads are cut on this end of the exercise, it is reversed in the lathe and the other end threaded in a similar manner.

To prevent the screw of the dog from marring the portion already threaded two nuts should be screwed on and the dog fastened to the nuts.

How to Reset the Tool.—When cutting threads of this size and larger, the tool usually becomes dull from taking the heavy roughing cuts. It is then necessary to resharpen it before taking the fine finishing cuts.

To reset the tool in the lathe first get the angles correct, as shown in Fig. 16. Then revolve the lathe forward by hand to take up the slack in the gears and move the tool in close to the threads. If the tool is in a position so that it will cut too much off one side of the thread, it may be changed by disengaging the reversing gears with the lever R and turning the lathe by hand.

When the tool is in the proper position relative to the groove of the thread, the reverse gear lever R is reset.

In a case where the tool is off the desired position only a very little, it may be corrected by the rapping process.

If the lathe has a compound rest the tool may be brought to the correct position by turning the hand-crank M.

It would be well for beginners to practice thread cutting on a piece of scrap steel before trying to cut them on the exercise.

EXERCISE No. 3.

CAST IRON FINISHED ALL OVER.

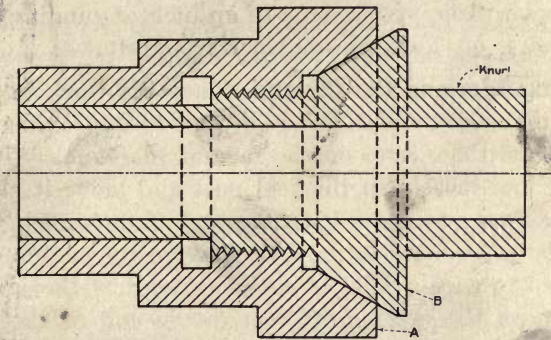

Sequence of Operations:

1. Finish the inside of Piece A.
2. Drill and Ream the hole in Piece B.
3. Mount B on mandrel and finish outside.
4. Screw A on B and finish the outside of A.

Piece A.

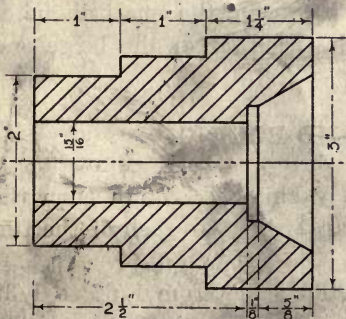

Fig. 19
Rough Casting

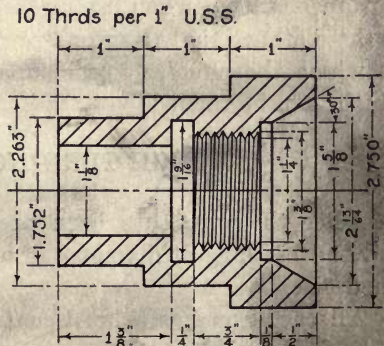
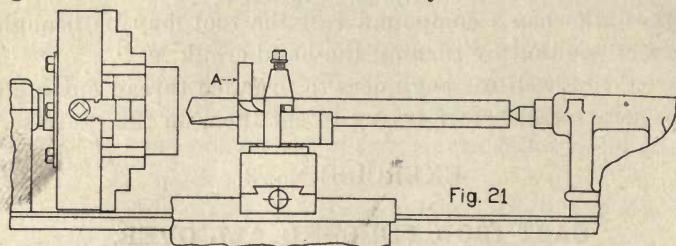

Fig. 20
Finished Casting

USE OF 4-JAW CHUCK.

To machine the inside of piece A it is necessary to hold it in the lathe by means of an independent four-jaw chuck, as shown in Fig. 21. Work of this kind is usually chucked so that the out-



side surfaces will be within $\frac{1}{32}$ of an inch of running true.

The process of chucking the work is as follows:

Centering Work in the Chuck.—Place the work in the chuck and adjust the jaws until they are all at approximately equal distances from the circles on the face of the chuck. Then put a cutting-off tool loosely in the tool post and move it close to the work and as near as possible to the end of the chuck jaws. Revolve the lathe by hand to prove if the work is centered. If it is not centered to within $\frac{1}{32}$ of an inch, readjust the jaws until it is. Now move the cutting-off tool to the end of the work and turn the lathe by hand. If the end runs out of true, rap it with a hammer at such points as will correct its position.

Advantage of Proper Chucking.—Fig. 21 shows the work held by the middle step of the cone. One reason for holding it in this way is to permit the rough turning of the larger step while in the chuck. If the work were held by the small end, it would be apt to work loose when taking the heavy roughing cuts on account of the distance that the work projects out and the small diameter on which the chuck grips compared with that of the large end which is to be turned.

ROUGH TURNING AND BORING.

After the work has been properly chucked, rough turn the end and the largest diameter to within $\frac{1}{32}$ of an inch of the finished size.

All cast iron has a hard surface, or scale, from $\frac{1}{64}$ to $\frac{1}{32}$ of an inch deep so that it is necessary to run the lathe slower for the first cut than for those made after the scale has been re-

moved. In taking this first cut the tool should be set deep enough to permit the point to cut under the scale.

Speed of Lathe.—The speed of the lathe in taking the roughing cut on work of this size should be about right if the belt is on the smallest step of the cone and the back gears are used. After the scale is removed, the lathe may be run faster.

A beginner will require experience before being able to determine the proper speeds and feeds for the different kinds of lathe work.

Advantage of Roughing Inside.—As the inside of piece A must fit the outside of the piece B, the $1\frac{1}{8}$ inch hole, the threads, and the taper must be machine true with each other, or else A will not fit into B properly. Now if the taper should be finished and the work moved in the chuck before the threads and the $1\frac{1}{8}$ inch hole are finished, they would not be true with each other. For this reason it would be well to rough bore the inside to within $\frac{1}{32}$ of an inch of the finished size before any of these three parts are finished.

Roughing Inside.—To rough bore the taper use a regular turning tool. Set the compound rest to the correct angle and feed the tool in at that angle.

If the lathe is not provided with a compound rest, the taper may be rough bored by turning both feeds by hand and following the cored surface as closely as possible.

The cored hole in the rough casting, Fig. 19, is $\frac{15}{16}$ of an inch in diameter which allows $\frac{3}{16}$ of an inch for finishing the $1\frac{1}{8}$ inch hole and $\frac{5}{16}$ for the portion where the threads are to be cut.

Use of Flat Drill.—To rough bore the hole a $1\frac{1}{16}$ flat, or lathe, drill is used as shown in Fig. 21. The holder A is clamped in the tool post so that the slot in it will hold the drill at the center of the lathe. If the drill is held above or below the center, the hole will be drilled larger than the drill. To prove that the slot in the holder is at the center, move it close to the tail-stock center. After the holder is properly set, move it as close to the work as possible and feed the drill into the exercise by turning the hand crank on the tail-stock.

This drill removes the hard surface, or scale, and also trues up, or centers, the hole to within $\frac{1}{64}$, or $\frac{1}{32}$ of an inch. Now enlarge the portion of the hole where the threads are to be cut with a $1\frac{3}{16}$ drill.

To determine when this drill has been fed in far enough, mark on the drill with a piece of chalk the distance from the end of the work to the point where the recess is to be cut. By sighting across the end of the work the operator can then see when the drill has been fed in the proper distance.

Use of Boring Bar.—To cut the square shoulder where the threads begin and the recess where they end, use a tool and boring bar, as shown in Fig. 22, held in the tool post. The width of this

Fig. 22

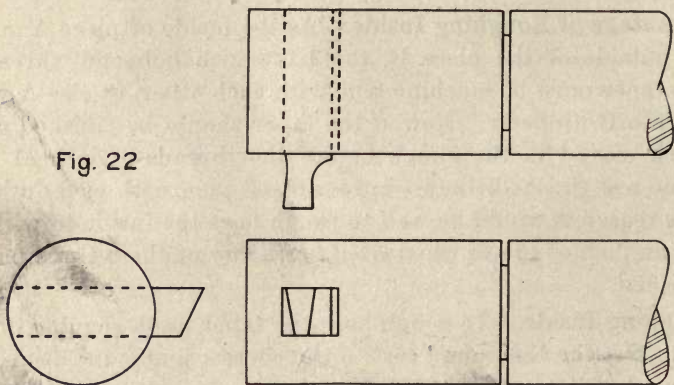

tool is $\frac{5}{32}$ of an inch so that it will be necessary to take two cuts to make the recess wide enough. Such a narrow tool is used because it is less liable to chatter.

This tool is ground with clearance at the sides as well as at the front and it should also be noticed that it is wider at the cutting edge than back close to the boring bar. This is done so that when the tool is fed into the work there will be little, or no chance of its binding on the side.

To obtain the correct setting for the tool, move the boring bar into the hole and bring it up close to one side. The tool should then be adjusted until its cutting edge is parallel to the elements of this surface.

The work is now all roughed out so that it makes very little difference which of the three fitting parts is finished first.

FINISHING INSIDE

The $\frac{11}{8}$ inch hole has been drilled with a $\frac{11}{16}$ inch lathe drill, but as such a tool cannot be relied upon to drill true to center, or size, it is necessary to turn it out with a boring tool. With

this tool the hole can be bored true to center and within .01 of an inch of the finished size.

The boring bar used in this case is the same as shown in Fig. 22, but the cutter has a rounded point and is similar to the tool used for outside turning except that it is ground with less clearance.

To insure accuracy and conserve time, the hole is then finished with a shell reamer held in the lathe as shown in Fig. 23.

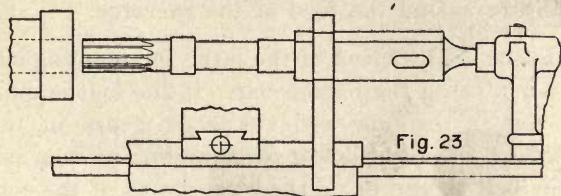

Reaming the Hole.—Before starting the reamer, the hole should be bored at the end, for a distance of about $1/8$ of an inch, to the size which will just permit the reamer to enter. This diameter must be calipered very carefully and should be tested with the reamer itself. The rest of the hole is then bored about .01 of an inch smaller in diameter to allow enough material for finishing with the reamer. Since the reamer used in this case cuts on the sides as well as on the end, the hole must be bored true to center in order to be reamed true.

If the reamer has a tapered shank, it is held in the lathe by a square shank socket and wrench, as shown in Fig. 23, and is fed into the work by turning the hand-crank on the tail-stock.

In case the reamer has a straight shank, it is held as shown in Fig. 24. Here a dog is fastened to the end of the reamer and pre-

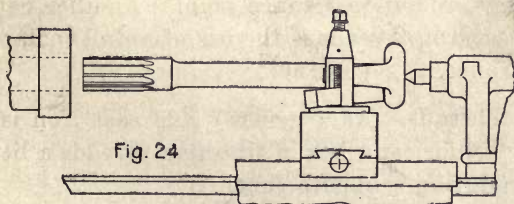

vented from turning by a tool clamped at an angle in the tool-post. The end of the tool presses against the dog near the shank of the reamer so that as the reamer is fed into the work the carriage of the lathe is forced along with it. This causes the tool

to hold the end of the reamer against the center of the tail-stock.

When reaming work in a lathe, if the tail-stock is off center the hole will be reamed too large at the front end.

Accurate Boring with Boring Bar.—In turning out holes with a boring bar, if all the cuts are started from one end, that end will be bored larger than the other. In case the hole is to be reamed, the reamer will correct this, but if the hole is to be finished with the boring bar it will be necessary to bore the hole from both ends. This is done by reversing the feed of the carriage.

Speed of Lathe.—The speed of the lathe for reaming should be slower than when using the boring bar. If the belt is on the second smallest step of the cone with the back gears in, the lathe should have about the right speed for reaming. When using the boring bar, the belt should be on the largest step of the cone without the back gear.

INSIDE THREADING

The inside threads are cut in very much the same manner as the outside ones. The cutting tool is held in the boring bar and, like all boring tools, is ground with less clearance than tools used for outside work.

To regulate the depth of each cut, the screw in the adjustable stop is placed between the stop and the cross-rest. Then by turning the screw in after a cut has been taken the cross-rest can be drawn back to permit a deeper cut with the tool.

Cause of Threads Breaking.—When cutting threads in cast iron, they will break if the roughing cuts are too heavy and are liable to if they are cut to a sharp point. Another cause for the breaking of cast iron threads is the use of a dull tool, or one with too little clearance.

Finishing Threads.—As a general rule cast iron is machined without using a lubricant, but in finishing threads a little lard oil will aid in producing a smooth finish.

FINISHING ENDS

The end of the work may be finished by taking a very light cut with the turning tool and then scraping it with a lathe scrap-

er, as shown in Fig. 25. To provide a rest for the scraper a tool

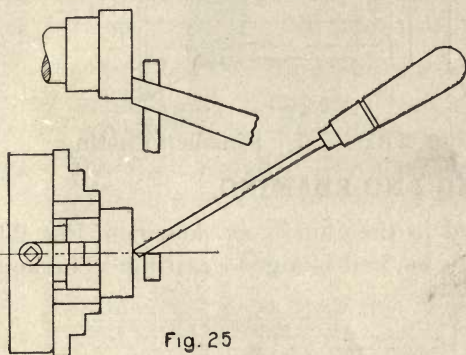

Fig. 25

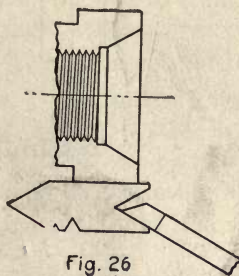

Fig. 26

is clamped in the tool-post and as close as possible to the surface being scraped.

A scraper is usually made from an old file ground smooth on the two sides and with a little clearance at the end.

FINISHING TAPER

To finish the taper, set the compound rest at an angle of 30 degrees with the axis of the lathe. Such a rest is normally at right angles with the lathe axis so that it must be turned through 60 degrees to cut the 30 degree angle. A regular turning tool may be used to finish this angle, but it should be set so that the straight side will be nearly parallel with the tapered surface.

If the lathe is not provided with a compound rest, the angle may be cut with the side of a tool set at the proper angle. To set this tool, use the thread and center gauge, as shown in Fig. 26.

In case the angle is any other than 30, or 60 degrees, it is necessary to set the tool with a bevel and bevel protractor.

After the taper has been cut, it may be finished smooth by scraping with a lathe scraper in very much the same manner as shown in Fig. 25. The tool that is used as a rest is set in as close as possible to the taper. If this rest is too far away from the surface being finished, the scraper will chatter leaving a rough surface.

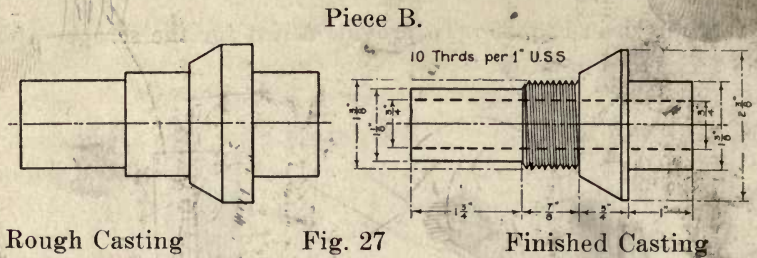

DRILLING AND REAMING.

This piece is first placed in the chuck, as shown in Fig. 28, and the end rough turned to see if it is a good casting. The hole

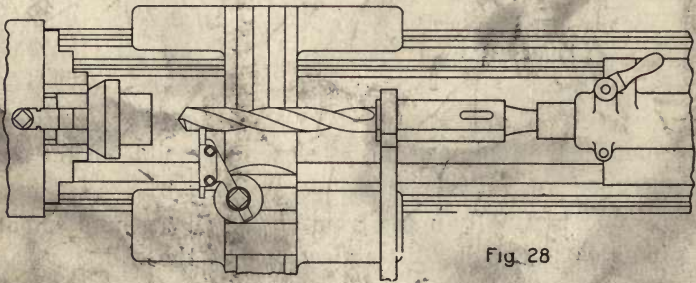

is then drilled with a $\frac{23}{32}$ inch twist drill and reamed out to size with a $\frac{3}{4}$ inch rose reamer.

Centering Twist Drill.—This drill will not bore a hole in the center unless the point is controlled in some way. To do this, a cutting-off tool is clamped in the tool-post with its point well above the center of the lathe and is then moved close to the point of the drill. As the drill starts to cut, it wobbles a little on account of the point being off center. The cutting-off tool is then gradually brought against the drill which is at the same time being slowly fed into the work by turning the hand crank on the tail-stock. It is necessary to have the drill centered true before it begins to cut the full diameter.

The drill should be placed in the tail-stock so that the cutting edges are vertical. If they are horizontal, it will be difficult to make the drill center.

If the hole in this piece were larger, it would be cast with a core and then machined in the same manner as the $1\frac{1}{8}$ inch hole in piece A, but since it is cast solid, the hole can be machined more advantageously by using a twist drill and a rose reamer.

Reaming.—After the hole has been drilled with the $\frac{23}{32}$

drill, bore it out with a small boring tool for about $1/8$ of an inch from the end to the diameter that will just fit over the reamer and insure its starting true. Ream the hole with the reamer held in the same manner as the twist drill in Fig. 28.

Speed of Lathe.—The lathe should run slower for reaming than for drilling. The speed will be about right for this size reamer if the belt is on the largest step of the cone without the back gears being used. The speed for the drill may be much faster. With a high-speed steel drill, the belt can be run on the second smallest step of the cone. If the drill is made of carbon steel, a slower speed should be used.

Advantage of Rose Reamer.—In drilling long holes like this, the drill is very apt to get off center a little as it is fed deeper into the work, even though it may have been started dead true.

The reamer used in this case is called a rose reamer, or rose bit, and cuts on the end only. For this reason, if the hole is approximately true, say within $1/64$ of an inch, it will ream the hole straight and true to size if it is once started true.

FINISHING CORNER

After the hole is bored and reamed, the work may be finished at the end by using a tool ground like a threading tool, but having an angle at the point a little less than 90 degrees, as in Fig. 29.

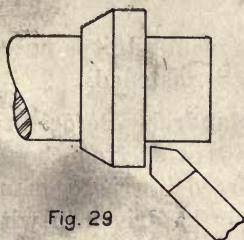

Fig. 29

The boss, or hub, which is $1 \frac{3}{8}$ inches in diameter, is finished with one cutting edge of this tool set nearly parallel to the work, the point being a trifle deeper than the rest. This will insure the full depth of cut for the entire length and also a good sharp corner. The direction of feed for this tool should be from the end and towards the square corner or shoulder. If it is fed in the opposite direction the tool is apt to chatter.

This tool is also used to finish the end, but it is turned a little

in the tool-post so that the other cutting edge is nearly parallel to the surface to be cut. After using this tool, the work may be finished smoother by scraping the ends, as in Fig. 25, and by filing the boss, or hub.

USE OF MANDREL, OR ARBOR

Before this piece can be finished on the outside, it must be forced on a mandrel, or arbor, and placed in the lathe, as shown in Fig. 30. Most commercial shops are provided with hardened

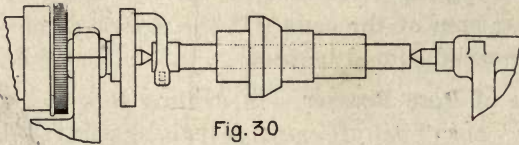

Fig. 30

steel mandrels for this purpose, but if one is not available it can be made from soft steel in the following manner:

Making Mandrel.—Cut off a piece of steel of suitable length, say 6 inches, and rough turn it to within $1/32$ of an inch of the diameter of the hole. Then turn it at the end for a distance of about $1/8$ of an inch to the size that will just fit the hole. The rest of the distance is now turned .002, or .003 of an inch larger and filed for about 3 inches until it will just fit the hole. The next 2 inches are filed with a slight taper so that when the mandrel is pressed into the hole it will fit tight enough to hold the casting while it is being turned. This kind of a fit is called a forced, or driving fit.

When making such a mandrel, it is not necessary to turn that portion to which the dog is fastened.

Mounting Work on Mandrel.—Before pressing the mandrel in, it should be oiled to prevent it from being marred, or scored. Mandrels are usually forced in with a mandrel press, but if one is not available, they may be driven in with a hammer. When this method is used, a piece of lead, or some other soft material, must be held on the end of the mandrel to keep the hammer from marring the center.

FINISHING OUTSIDE OF PIECE B TO FIT A

This casting is rough turned to within $1/32$ of an inch of the finished size before any part of it is finished. The $1\ 1/8$ inch end is then turned until it fits the corresponding part of the hole in

piece A as closely as possible and yet not so tight that it cannot be freely rotated. This kind of a fit is called a close running fit.

Cutting Threads.—The portion to be threaded should be turned a little smaller than the diameter at the bottom of the threads in piece A. This size is measured by means of the inside spring-thread calipers.

There is no recess, or groove, cut at the end of this thread so that if the threading tool is allowed to travel farther than the end of the preceding cut, either the point of the tool or the threads may break. To prevent this, the lathe is stopped when the tool is within a half a thread of the end and the cut finished by turning the lathe by hand. In this way the lathe is kept under control and the tool may be drawn back when it reaches the end of the preceding cut. Experienced lathe operators do not, as a rule, turn the lathe by hand, but control the lathe entirely by the shipper.

The speed of the lathe for cutting this thread will be about right for beginners if the belt is on the second smallest step of the cone and the back gears are thrown in.

Finishing the Angle, or Taper.—The 30 degree angle may be cut by setting the compound rest to the correct angle and using a regular turning tool. In case the tool leaves a few tool marks, they may be removed by filing.

If the lathe is not provided with a compound rest, this angle may be cut by setting a square-nose tool, as in Fig. 31, with the

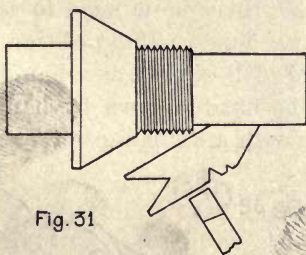

Fig. 31

aid of a thread gauge. Any other angle would have to be set with a bevel and bevel protractor.

This tool is not as wide as the surface to be cut because one that will cut the full width is very liable to chatter. It is therefore better to make several cuts with a narrow tool. The surface can then be finished smooth by filing.

The closeness of the fit of this taper with that in A can be

tested by rubbing black paint, which consists of lamp black and oil, on the tapered surface in A. When B is screwed into A, marks will be made on B indicating the high spots. If these are not too high, they may be removed by filing.

FINISHING OUTSIDE OF PIECE A.

Piece A may now be screwed on B and the outside rough turned to within $1/32$ of an inch of the finished size.

The ends of the different steps are finished to the proper length with the tool shown in Fig. 29. This same tool can then be used to turn the different diameters to within 0.002 or 0.003 of an inch of the required size. These steps are brought to the final size by filing.

Filing.—The file for this work should be less than 1 inch in width. If it is wider than the steps, a beginner will usually file the portion at the end of each step smaller in diameter than that which is close to the square corners.

The different diameters may be measured accurately with the micrometer calipers.

KNURLING

After piece A is finished, it is removed from B and B is reversed in the lathe so that the boss may be knurled.

In case there is enough room between the dog and the work, when held as in Fig. 30, there is no need to reverse the work for knurling since it can be done in this position.

The boss at the end of B is used as a handle so that if it were left smooth it would be hard to turn by hand. The surface is therefore made rough with a knurling tool as shown in Fig. 32.

Fig. 32

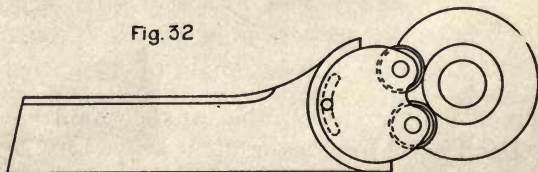

The speed of the lathe should be about the same for knurling as for thread cutting. If the lathe runs too fast, the knurling tool does not cut satisfactorily.

The tool is set so that the face of the rollers is parallel with

the surface to be knurled. When starting the cut, the rollers can be forced into the piece easier if about half of their width extends past the end of the work.

The knurling tool should be pressed into the work fast enough so that about one half the depth of the finished knurl will be cut while the lathe makes three or four revolutions. If the tool is forced in too slow, it will cut a finer knurled surface than the rollers are intended to cut.

The tool is fed along the surface in the same manner as in plain turning. The speed at which the carriage of the lathe moves has no effect upon the pitch of the knurled surface since this is controlled by the pitch of the grooves in the rollers. If a finer knurled surface is desired, a knurling tool having rollers with finer grooves would have to be used.

PART II.

WISE, SHAPER, DRILLING AND TAPPING

PART II

THE WATER BILLS AND TAPPING

VICE WORK

Although most of the metal cutting in the machine shop can be done by machine, it is sometimes necessary, even in the most modern shops, to do some of it by hand. In order to give the student practice in this hand, or vise work, the sides A and B of the cast iron block, Fig. 1, are to be finished by chipping, filing and scraping.

EXERCISE NO. 4

CAST IRON BLOCK

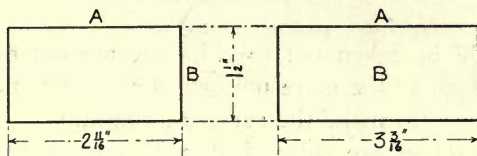

Fig. 1

Sequence of Operations:

1. Chip and file side A.
2. Scrape side A true to a surface plate.
3. Chip and file side B square with A.
4. Scrape side B true to surface plate.

Chipping.—The original surface of cast iron is very hard for a depth of about $\frac{1}{64}$ of an inch and is almost impossible to file. It is therefore necessary to remove this hard scale with chisels before starting to file.

For this sort of chipping, cape and flat chisels, Figs. 2 and 3, respectively, are used.

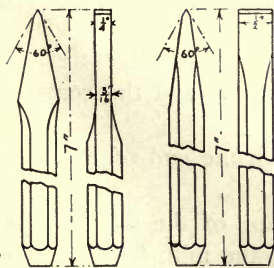

Fig. 2

Fig. 3

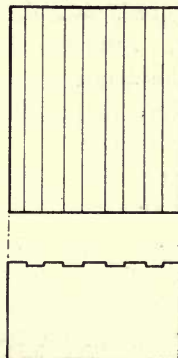

Fig. 4

Parallel grooves are first cut in the surface as shown in Fig. 4. These grooves must be just deep enough to get under the scale, i. e., not less than $1/32''$ nor more than $1/16''$ deep. When they have been cut to within $1/4$ of an inch of the end, the direction of chipping should be reversed to prevent breaking out the cast iron at the corner.

The grooves should be uniformly spaced, in this case, about $1/4''$ to $5/16''$ apart. On heavier work, where larger chisels are necessary, the grooves are cut further apart. Generally the distance between the grooves should be about equal to the width of the cape chisel used.

Care should be taken not to chip one portion of the surface deeper than another; the more uniform the grooves the less will be the filing required to make the surface straight.

The metal ridges are chipped off with the flat chisel shown in Fig. 3.

Sharpening the Chisels.—To do good work the chisels must be kept sharp by grinding on a fine grinding wheel. Care should be taken not to hold them too hard against the wheel, thus drawing the temper.

If the chisels are to be used for very light cuts, say $1/64$ of an inch deep, the cutting edge may be ground to a smaller angle than is shown in Figs. 2 and 3.

FILES AND FILING

Files.—While there is a large variety of shapes and sizes of files manufactured, only the ones to be used on these exercises will be described. Students desiring further information on files should consult the catalogue of some standard file manufacturer.

Files are designated by their size, type, and the coarseness or cut of their teeth.

The size refers to the distance from the end of the file to the point where the tang begins, Fig. 5.

The type refers to the general shape of the file. Those most commonly used in a machine shop are the mill, flat, hand, square, round and half-round files.

The mill, flat and hand files are very similar in shape, but differ from one another in detail.

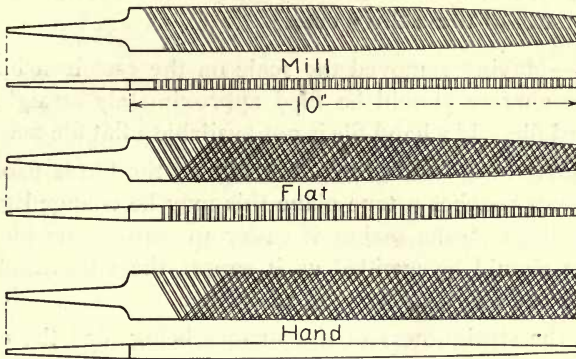

Fig. 5.

The *mill file* is uniform in thickness, tapered in width and is single cut, i. e., has only one course of teeth. It is used principally for lathe work.

The *flat file* is tapered in both width and thickness and is double cut. It is intended mainly for general use and is not suitable for lathe work.

The *hand file* is uniform in width, tapered in thickness and double cut. It is a little wider than the mill and flat file and has one safe edge, i. e., one edge without teeth.

The advantage of this safe edge is that the file may be used close up to a square corner without cutting in at the side. This file is preferred by machinists for flat surfaces, although the flat file may also be used for such work. An edge of a flat file may be made safe by grinding off the teeth.

The *common square file* is tapered and double cut. It is used for filing square and rectangular holes and on square corners. For this kind of work one edge should be safe.

The *common round file* is tapered and double cut. It is used for filing round holes, concave surfaces, etc.

The *half-round file* is tapered and double cut. It is used on large round holes, concave surfaces and acute angles. The latter use is illustrated in Fig. 31, page 25.

The coarseness or cut of a file refers to the spacing of the teeth. The three different spacings, or cuts, in common use are the bastard,

second cut and smooth. Practically all of the common files may be obtained in any of these three cuts.

Filing.—Having removed the scale on the cast iron block with chisels, the surface should be filed approximately straight with a hand bastard file. If a hand file is not available a flat file may be used.

In the first rough filing, a full stroke of the file is used, but as the surface approaches a true plane this may be changed to a short stroke. A short stroke makes it easier to control the file. Rocking the file should be avoided as it causes the edges and corners of the work to be filed lower than the center.

To test the straightness of the surface being filed the edge of a steel rule is held on it in several positions.

When filing work of this kind it is advisable to file in different directions, i. e., parallel with one edge, crosswise and diagonally.

The teeth of all files are made to cut on the forward stroke. For this reason the pressure should be relieved on the return or backward stroke.

It will be noticed upon sighting along the edge of a hand file that the thickness does not taper uniformly, both sides being slightly convex. The curves are supposed to be uniform, but the warping that occurs in tempering causes greater convexity at one place than another. By using the file at the point of greatest convexity and by giving it a short stroke the work may be filed straight even though the file does rock a little. If the file is warped to the extent that one side is slightly concave it will be impossible to file the work straight with that side.

After the surface has been filed straight with the coarse or bastard file it is finished smoother with a hand or flat smooth file. Instead of filing in different directions, as in rough filing, the strokes should be parallel with one edge of the work. This causes all the scratches or lines made by the file to be parallel, giving the surface a better appearance. If it is to be scraped, as in this case, this will also make it much easier.

When filing cast iron the file dust should never be brushed off the work with the hand, as the hand deposits more or less grease, causing the file to slip and dull quickly. Machinists usually blow off the dust. When filing wrought iron or steel, oil or grease does no harm, in fact oil is sometimes used to produce a smooth finish.

SCRAPING

After the surface A has been filed smooth and approximately straight, it is finished to a plane surface with a surface plate and scraper.

Use of Surface Plate.—To locate the high places on a flat surface a surface plate, Fig. 6, is used. The size of the plate is usually a little larger than the surface being scraped. The side A is first covered with a thin film of paint made of lamp black and lard oil. It is then placed in contact with the surface to be scraped and moved around over it, marking the high spots.

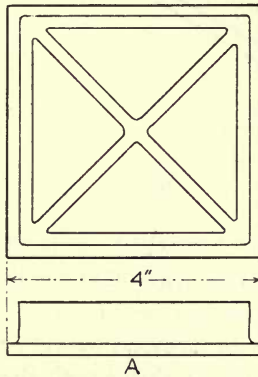

Fig. 6

The paint should be spread on the plate with the finger tips and just thick enough to cover it. If waste or cloth is used, lint is deposited on the plate and interferes with the marking. If it is spread on too thick, the low places will be marked as well as the high ones.

It is very easy to locate the high spots if the work is a little concave, but if a little convex the plate is apt to rock when moved over the surface, thus marking the low as well as the high spots. This makes it very important to use as little paint on the surface plate as possible, and to move it over the work without rocking.

After locating the high spots the scraper is used on them and the work again tested with the plate. These operations are repeated until the surface is true.

Use of the Scraper.—In use the scraper is held firmly with both hands at about the angle shown in Fig. 7. The cutting is done by

holding it down hard on the work and moving it forward in the direction indicated by the arrow. If the handle is held too high or too low the scraper will not cut satisfactorily. A little practice will be required before a beginner can properly control it.

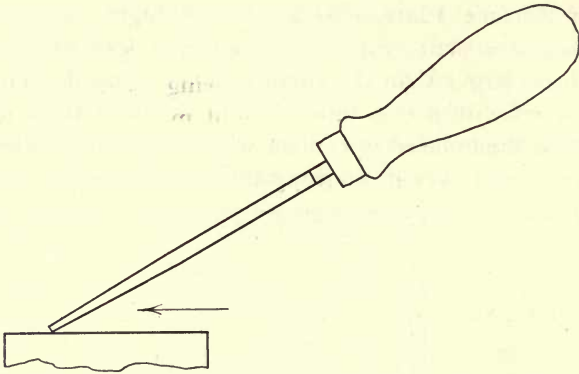

Fig. 7

When using the scraper it will be noticed that it has a tendency to chatter, causing a slightly wavy line cut instead of a smooth one. If all the scraping is done in one direction these chatter marks become deeper. This may be avoided by varying the direction of the scraping a little after each marking with the surface plate.

The scraper is usually made from an old 10-inch file by grinding off the teeth and forging it to the shape shown in Fig. 8.

Grinding the Scraper.—After forging and hardening, the scraper is ground straight on the side B, Fig. 8, and slightly convex across the end A. If the latter edge is curved too much, the scraper will take too narrow a cut, while if it is perfectly straight the cut will be so wide that it will not be smooth. The scraper should be ground so as to take a cut about $\frac{1}{4}$ of an inch or wider.

The edge C should be ground at right angles with the center line of the scraper.

Caution.—The scraper is made of carbon steel and is tempered very hard. Beginners are therefore cautioned not to draw the temper by grinding it too fast. This often happens without being noticed so that the beginner is unable to understand why his scraper will not cut.

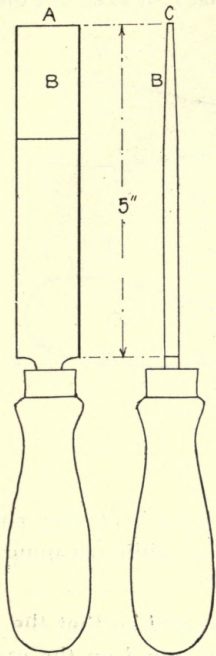

Fig. 8

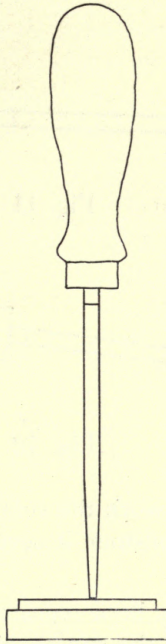

Fig. 9

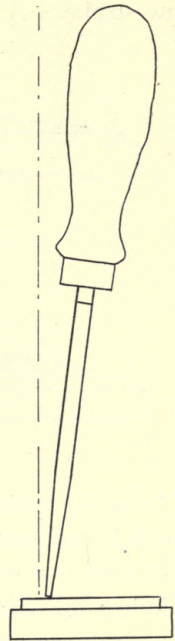

Fig. 10

Oilstoning the Scraper.—The grinding wheel produces a somewhat rough cutting edge which must be oilstoned before the scraper will cut smoothly. This oilstoning is done by moving the end and the sides of the scraper alternately over the surface of a flat oilstone.

When oilstoning the end it may be held vertically, Fig. 9, or at a slight angle, as in Fig. 10. If held at an angle the sharpening is done a little quicker and the edge will be slightly beveled. Such an edge will cause less chattering than the one obtained by oilstoning as in Fig. 9. When one edge has been sharpened the scraper is turned over and the other edge sharpened in the same manner.

Fig. 11 shows the correct position for oilstoning the side. The handle should not be raised, as in Fig. 12, as this would take off the sharp edge. A fine wire or feather edge is produced, no matter how hard the scraper is tempered. To take advantage of it, the scraper should be oilstoned on the side last if it is to cut on the

forward stroke, as in Fig. 7, and on the end last if it is to cut on the draw stroke.

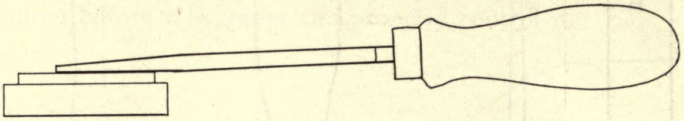

Fig. 11

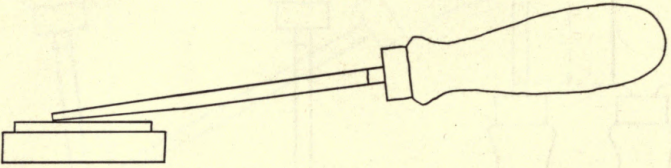

Fig. 12

In order to do good work the scraper must be kept very sharp. It will be necessary to oilstone it several times while scraping the surface of this exercise.

When the scraper has been repeatedly oilstoned so that the cutting edges are worn off, the end should be reground on the grinding wheel to the original shape, as shown at C in Fig. 8.

Finishing Side B.—After side A of Exercise 4 has been finished, the side B is squared with A by the same process, i. e., by chipping, filing and scraping.

If B is very much out of square with A, one side of B may be chipped a little deeper than the other. In doing this it will be better to take several light cuts with the cape chisel than to try to remove too much metal in one cut. Too deep a cut will cause the edge of the chisel to break.

SHAPER WORK

An up-to-date shaper is shown in Fig. 13. The four-step cone drive with back gears gives eight speeds. Two sides as well as the top of the table are provided with slots for clamping work that is too large to be held in the vise.

The table may be raised or lowered by means of the hand crank shown at the end of the cross-rail. By placing this crank on the shaft immediately above it the table may be fed horizontally by hand.

The automatic table feed is started, stopped or reversed by means of a small knobbed pin which engages the ratchet gear at the end of the cross-rail. The rate of feed is varied by changing the position of a large knobbed pin on the disc near the driving cone. The hand crank above this disc is used for changing the length of the stroke. The position of the stroke is changed by loosening the lever on top of the ram and turning the squared shaft shown near the head of the ram.

Shapers are usually designated by their maximum length of stroke; as, a 16-inch or a 20-inch shaper.

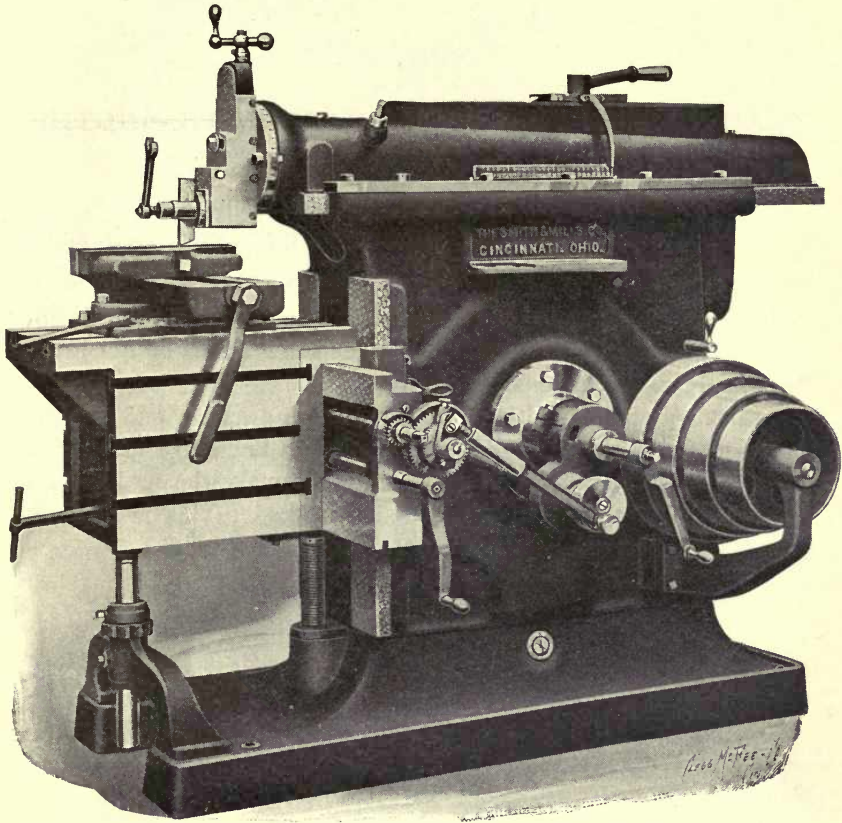

Fig. 13
20-INCH SHAPER

EXERCISE NO. 5

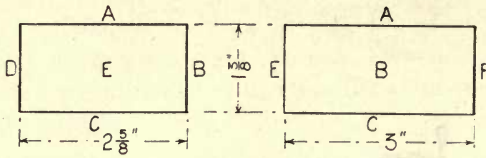

Fig. 14

PLANING ONE SURFACE SQUARE WITH ANOTHER

Sequence of Operations:

1. Clamp in shaper vise and plane side D square with A.
2. Plane the ends E and F square with the sides A, B, and D.

In taking up the exercise on the shaper it is assumed that the sides A and B of the cast iron block in Fig. 14 have been finished true and square in the vise. The other sides are to be finished on the shaper to the dimensions given.

First lay off the width of the side C with a scribe and combination square, as shown in Fig. 15, marking a line $2\frac{5}{8}$ inches from the side B and parallel with it. In order to make the scribe marks plainly visible the surface should be chalked. This is especially necessary when the hard scale has not been removed.

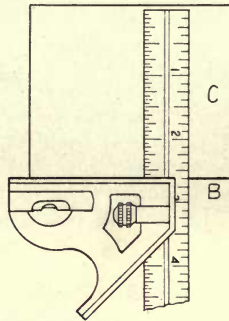

Fig. 15

Clamping the Work.—The work is clamped in the shaper vise with the finished side B resting on the base and with the side A against the stationary jaw of the vise, as in Fig. 16. A piece of paper should be kept under each end of B.

The clamping bolt J may be left loose until the jaw is close to the work. It should then be tightened so that as the jaw is screwed up against the work it will not be raised off the base of the vise.

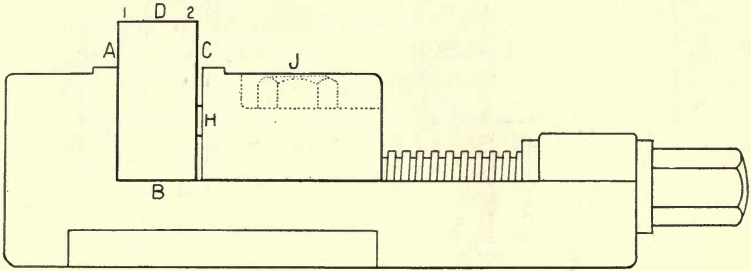

Fig. 16

The narrow metal strip shown at H should be about $1/16''$ x $1/2''$ x $6''$. It is used so that when the vise is tightened the pressure on the block will be about at the center. This holds the side A tight against the solid jaw. By rapping side D with a hammer B is forced down on the base of the vise until the paper at both ends is tight.

The work is now ready for the roughing cut. This is taken with a tool or bit similar to the one used on the lathe, but which has less clearance since it cuts along a straight line. The lathe tool holder is sometimes used on the shaper, but a regular shaper tool holder, Fig. 17, is preferred. The latter has an adjustable head or clamp so that the tool may be turned at different angles. The piece of tool steel used in such a holder should always be longer than the diameter of the head, otherwise it will not be held firmly.

Depth of Cut.—The depth of the roughing cut depends mainly upon the size of the machine and the amount of metal to be removed. If $1/8$ of an inch is to be cut off take a little more than half that amount the first cut.

Rate of Feed.—This also depends largely upon the size of the machine. With large and heavy machines deep cuts may be taken and coarse feeds used.

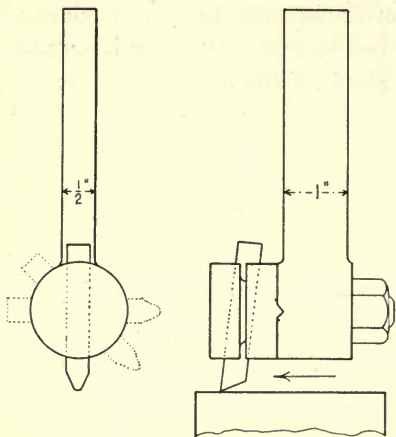

Fig. 17

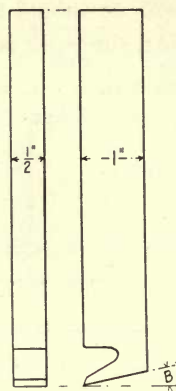

Fig. 18

If a small shaper is used, as is generally the case with work of this sort, the rate of feed with a cut about $1/8''$ deep, may be about $1/64$ of an inch. With a cut only $1/16''$ deep the feed may be increased to $1/32''$ per stroke.

Testing the Work for Squareness.—After the first roughing cut, a finishing cut is taken and the work removed from the vise. It is then tested with a square to make sure that the surface being machined is square with side A. The stationary jaw cannot be depended upon to hold the work square.

The finishing tool, Fig. 18, is forged from a piece of carbon steel. Care should be used in grinding it not to draw the temper. The advantage of using carbon steel instead of high speed steel for this tool is that it makes a smoother finishing cut and is cheaper and easier to forge. The cutting edge should be ground as straight as possible. It may be a little convex but never concave. The clearance angle B should be about 10° or 15° .

Setting the Finishing Tool.—In order to take a smooth finishing cut, the tool should be set with the cutting edge parallel, or nearly so, with the surface to be planed. This is done by clamping it loosely in the tool post and over but not touching the work. If the cutting edge is not parallel with the work, rap the tool until it appears to be so. Feed the tool down with the hand crank until it

just touches the work. Now move the ram of the shaper forward by pulling the belt by hand. The fine chip or dust removed by the tool will show if it is set in the proper position.

Direction of Feed.—If the tool appears to cut deepest at the center, it may be fed in either direction, Fig. 19, but if it is set so that one side cuts slightly deeper than the other, as in Fig. 20, the direction of the feed should be as indicated by the arrow. Feeding in the opposite direction is apt to make the tool chatter because of the wide cutting edge that is in contact with the work.

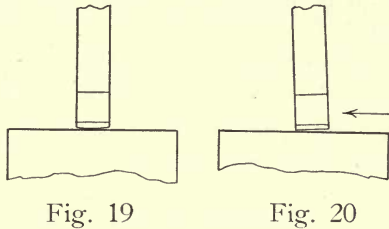

Fig. 19

Fig. 20

The curve of the cutting edge in Fig. 19 and the angle at which the tool is set in Fig. 20 are greatly exaggerated. The cutting edge should be straight within .002 or .003 of an inch and one side should not be set more than .002 or .003 deeper than the other.

Depth of Finishing Cut.—The finishing tool is intended for shallow cuts of not more than .01 of an inch and works better if still less is taken. In general practice it is customary to plane to the finish line with a roughing tool and use the finishing tool merely to remove the marks of the roughing tool. If .02 or .03 of an inch are to be removed several cuts should be taken.

Rate of Feed.—As the finishing tool has a wide cutting edge a coarse feed may be used. In this case about 1/8 of an inch per stroke will do. With most shapers this is about equivalent to one-half turn of the hand crank. The feeding should be done by hand and care taken to note the position of the crank after each turn. This insures a uniform rate of feed.

Resetting Work.—After the first finishing cut, the work is removed from the shaper vise and tested to see if the sides A and D are square with each other and if side D is parallel with B, Fig.

16. In case D is not square with A the setting in the vise may be corrected, within certain limits, by having the metal strip H higher or lower. When this strip is near the top of the vise the block will be very slightly tipped so that the edge 2 will be a little higher than 1. With H at or close to the bottom the effect will be just the opposite and a little more metal can be cut off at edge 1 than at 2.

If the two sides B and D are not parallel additional pieces of paper may be placed under the thickest end.

It may be necessary to take several trial cuts before the block is properly set in the vise. These cuts should be taken with the finishing tool since it is quickly fed across the work and does not remove much metal.

The work is now machined to the finished size. If it is necessary to remove more than $1/32$ of an inch of metal, time will be saved by first using the roughing tool, as the finishing tool is not intended to take more than .01" per cut.

Planing the End.—To plane the end of the block it is held in the vise in the same manner as when planing side D. It is first set approximately straight by using the square as in Fig. 21. In this view the solid jaw of the vise is not shown.

The base of the vise cannot be relied upon to be parallel with the travel of the tool so that a trial roughing and finishing cut should be taken to test the squareness of the surface E with the sides B and D.

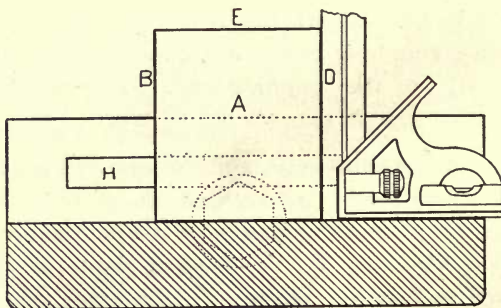

Fig. 21

If the block is not set square it may be tilted a little in the vise by holding the grain end of a piece of wood against one corner and

rapping the wood with a hammer. Another trial cut should then be taken and the process repeated if it is not square.

To Prevent Corners from Breaking.—It will be noticed that both the finishing and roughing tools break off the corner of the work at the outer end of the cut. To prevent this the corner is filed off at an angle of about 20° with the surface being planed, and as deep as the finishing cut is to be.

On work of this size the corner should be filed off when the surface has been planed to within $1/32$ or $1/16$ of an inch of the finished size. The important thing is to be sure to file off the corner before it breaks out deeper than the finished size.

EXERCISE NO. 6

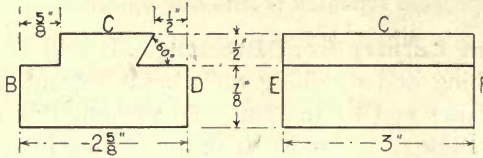

Fig. 22

PLANING ONE SURFACE PARALLEL WITH ANOTHER AND PLANING ANGLES

Sequence of Operations:

1. Lay off on one end of block the outline of the finished piece.
2. Clamp in vise, Fig. 23.
3. Plane side C to size with roughing and finishing tools.
4. Rough out the angles with a roughing tool, Figs. 24 and 25.
5. Finish the angles.

In laying off the outline of the finished piece the combination square can be used, as before, for the measurements and to mark the 90° angle. A thread gauge or a bevel protractor is used for the 60° angle.

Clamping in Vise.—The work is clamped in the vise as shown in Fig. 23. The parallels J and K are longer than the work and high enough so that the jaws of the vise grip on about $1/2''$ of the work. The object in clamping on only a small area of the sides is to make it easier to rap the work down on the parallels.

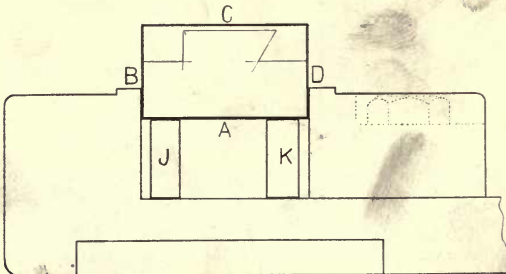

Fig. 23

Clamp the work tight, and rap the top with a hammer to force it down tight on the parallels.

Planing One Side Parallel with Another.—After taking a roughing and finishing cut, caliper the block at each corner to see if it is uniform in thickness. If one corner is thicker than another, place one or more pieces of paper under that corner and take another trial cut. This operation is repeated until the sides A and C are parallel.

Roughing Out the Angles.—The angles are roughed out with the regular roughing tool, cutting as close to the lines as possible. These roughing cuts should be heavy so as to remove the metal quickly. The tool should be started at the outside and fed toward the center. If the automatic feed is used it should be disengaged when the tool is within about $1/16$ of an inch of the finish line. When roughing out the angles, set the head, clapper box and tool as in Figs. 24 and 25.

Setting the Head, Clapper Box, and Tool.—Loosen the clamping screw N, Fig. 24, and move the clapper box to about the angle shown. The side of the tool should be nearly vertical as at O.

Setting the clapper box at this angle causes the tool to swing away from the vertical side of the work on the return stroke of the shaper. If it were set at the opposite angle it would swing into the work.

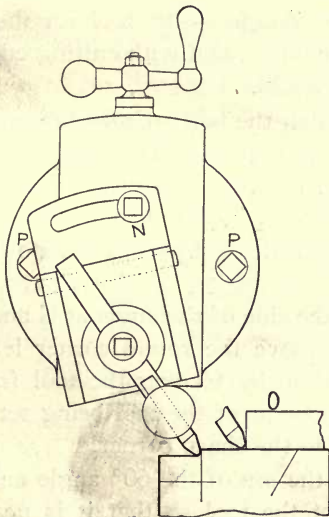

Fig. 24

For the 60° angle set the head to an angle of 30° with the vertical, using the graduations on the quadrant of the head R, Fig. 25. Move the clapper box to about the angle shown. It should be noticed that the angle at which this is set is just the opposite of the one used when cutting the 90° angle. This is because the tool is to cut on the opposite side.

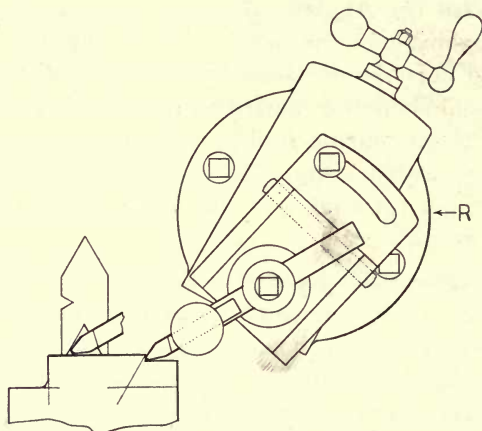

Fig. 25

Finishing the 60° Angle.—The tool for finishing the angle is ground a little less than 60° , and with cutting edges on the side and bottom, L and M, Fig. 26.

First adjust it so that the bottom edge is nearly parallel with the top of the block as at I in Fig. 27, being sure that the point is slightly deeper, say, about .001 of an inch, than the rest of the tool. To prove that this is so, pull the belt by hand with the tool just touching the work. The deepest part of the tool will remove a small chip or some dust.

Move the tool to the side of the angle at G and feed it down with the hand crank to remove the round corner left by the roughing tool. Finish the bottom by feeding the tool from the outer edge into the corner. The point of the tool being set deeper insures the full depth of the cut to the sharp corner.

Start a cut from the top of the 60° angle and feed down to the bottom. Now adjust the tool so that it is nearly parallel to the side as at H in Fig. 28, being sure that the point cuts the deepest.

Take a finishing cut beginning at the top and feeding down until the point just touches the bottom.



Fig. 26

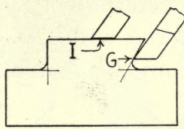

Fig. 27

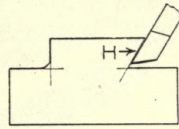

Fig 28

This tool, like practically all finishing tools, should be kept sharp by grinding and oilstoning. It should not be used for cuts of more than .01 of an inch in depth.

Finishing the Right Angle.—When the 60° angle has been finished, the 90° angle is finished in about the same manner. The head must be returned to its vertical position and the clapper box tilted as in Fig. 24. The tool used is ground a little less than 90° , Fig. 30.

The bottom, or base of the angles, S and T, Fig. 30, should be finished to the same level. To do this the tool is set so that it just touches the surface T. The final finishing cut is then taken on S without changing the height of the tool.

Filing the Angles.—After the angles are machined they may be finished smoother with a file. A 10-inch smooth square file with a safe edge may be used for the right angle as at U, Fig. 31, and a 10-inch smooth half-round file for the 60° angle. The latter should have a safe edge at V so it will not cut into the side when filing the bottom.

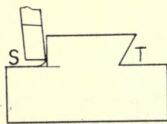

Fig. 30

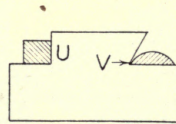

Fig. 31

DRILLING AND TAPPING

The size of a drill press is determined by the maximum diam. of the work which can be centered with the spindle. Hence on a 16-inch machine the distance from the center line of the spindle to the column is about 8 inches.

A 16-inch drill press is shown in Fig. 32. With a five-step cone it has five spindle speeds, ranging from 150 to 1700 revolutions per minute. This makes it an excellent machine for light drilling. Drills larger than 1/2 inch are not generally used. The spindle feed is controlled by the hand lever at the side of the spindle. The table may be raised or lowered by means of the hand crank on the column.

Fig. 33 shows a 20-inch complete drill with back gears. It has 8 changes of speed, ranging from 25 to 300 revolutions per minute. The back gears are located at the top of the machine and are shifted by means of the lever shown directly beneath them. This machine has both hand and automatic feeds and is also provided with an automatic stop for drilling a number of holes of the same depth. The drills used generally range from 1/4 inch to 1 1/2 inches, but larger or smaller ones can be used.

When work is clamped to the table of the machine, it may be moved to any desired position for drilling by rotating the table and swinging the table arm about the column. To hold the table in position the wrench shown underneath it and a similar one on the column are tightened.

The Hi-Speed Drill Press shown in Fig. 34 is built a little larger and heavier than the one just described. This machine will drive drills of high speed steel up to 1 1/4 inches in diameter to their full capacity. Eight changes of speed from 90 to 610 revolutions per minute are obtained by means of the enclosed gears at the top of the machine. It is also provided with hand and automatic feeds and an automatic stop.

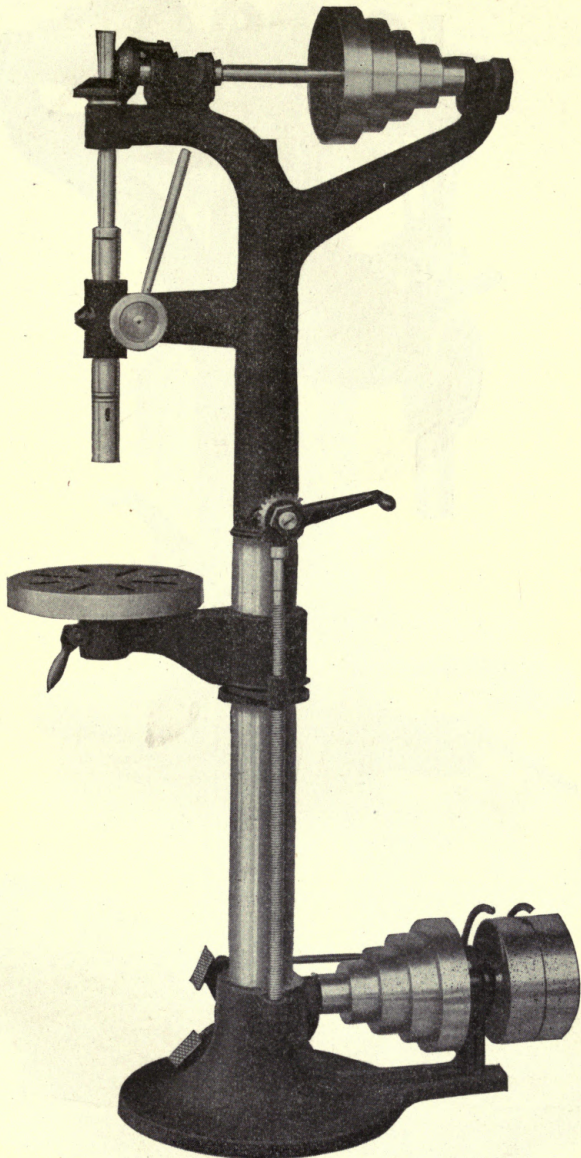

Fig. 32

16-INCH DRILL PRESS

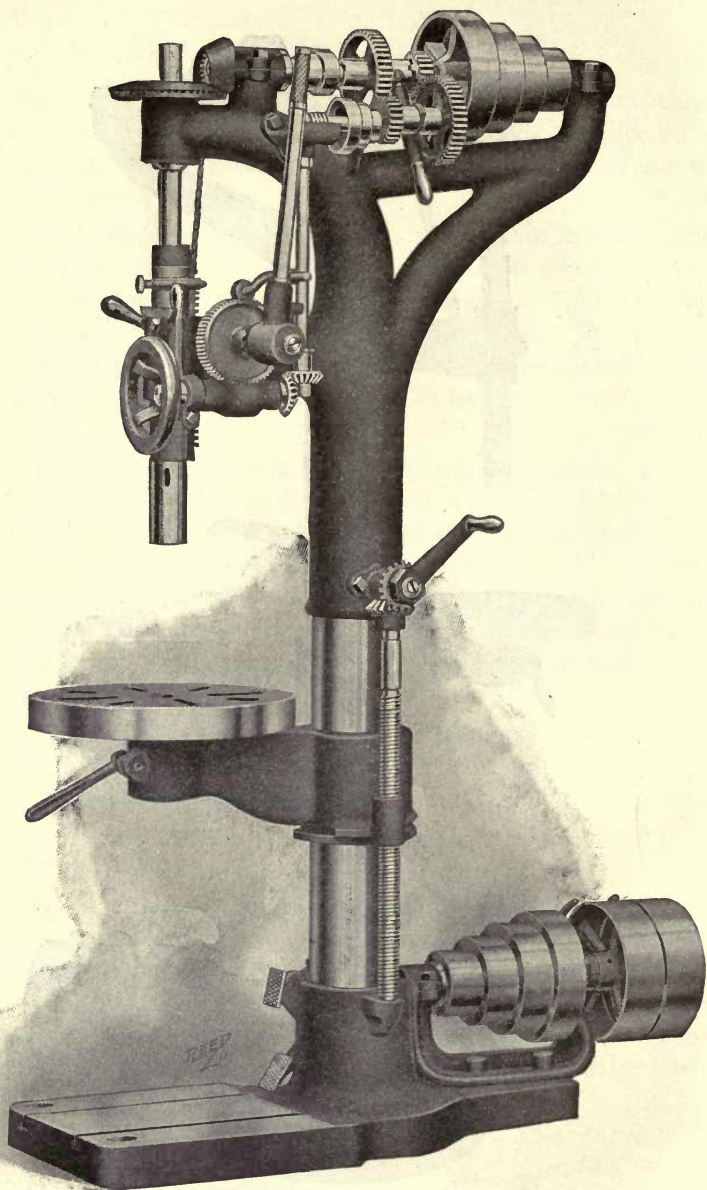

Fig. 33

20-INCH COMPLETE DRILL

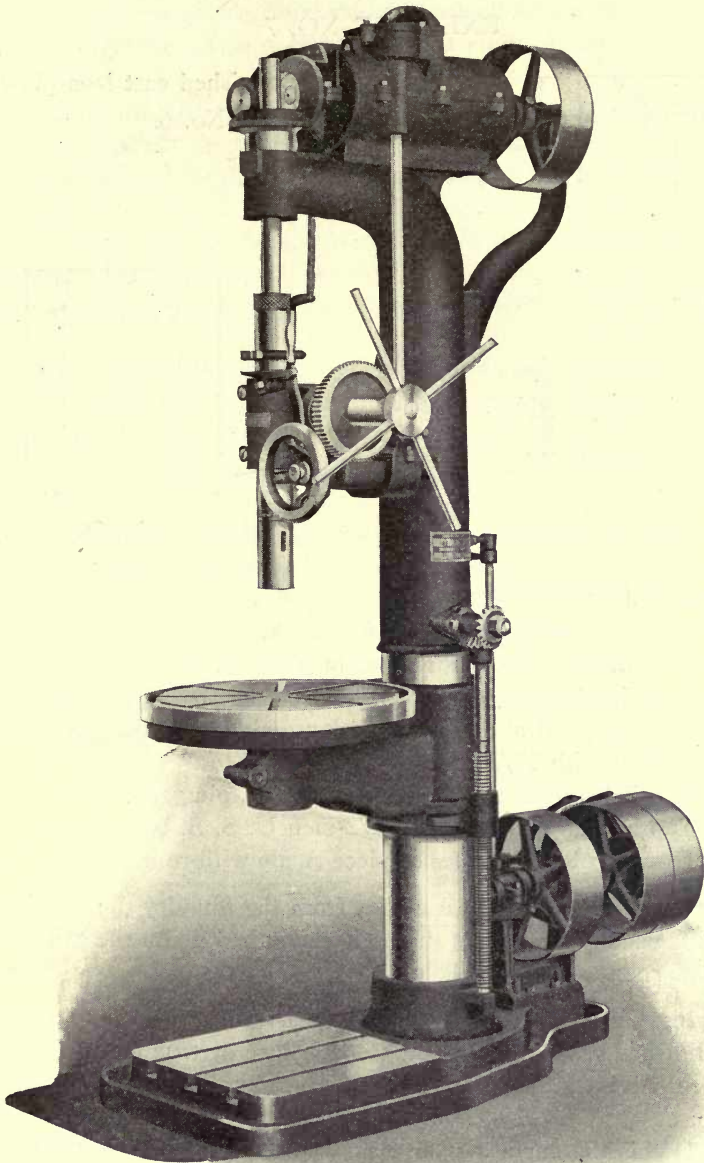

Fig. 34
HI-SPEED DRILL PRESS

EXERCISE NO. 7

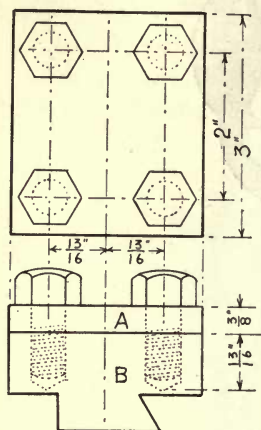

Fig. 35

Piece A is an unfinished cast iron plate.
Piece B is Exercise No. 6.

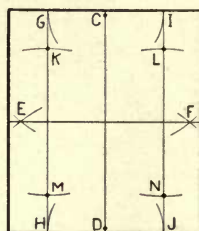

Fig. 36

Sequence of Operations:

1. Grind the rough surfaces of piece A.
2. Lay off the centers for holes in piece A.
3. Drill $1/2$ inch holes in piece A.
4. Place A on B and scribe position of holes on B.
5. Drill B with $13/32$ " drill $13/16$ " deep.
6. Tap holes in B with $1/2$ -inch U. S. S. plug tap.
7. Tap bottom of holes with $1/2$ -inch U. S. S. bottom tap.
8. If screws bind in holes of piece A file with round file.

Grinding Piece A.—As it comes from the foundry the cast iron piece A is usually rough. It should be smoothed up on the grinding wheel before laying out the holes.

Laying Out the Centers of the Holes.—Piece A being a rough and unfinished casting is not apt to be square or true to size. It is therefore advisable to first mark the center lines CD and EF, Fig. 36.

To do this the surface is first chalked to make the lines plainly visible. Mark C and D at the center of the two ends and as close to the ends as possible. Center punch them with a small center punch and draw a line between them. With a pair of dividers and with

C and D as centers describe the arcs which locate E and F. The line through these two points will be at right angles with CD and at its center.

Next mark with the dividers on each side of CD half of the total distance between the centers of holes and draw GH and IJ. From EF mark off on these lines the required spacing of the holes K, L, M, and N.

To prove that the hole centers are laid out square, measure the distance from L to M and from K to N with the dividers. Check the layout with a rule to see if the centers are the correct distances apart.

When the intersections are in the right positions for the hole centers, mark them with a small center punch. Now scribe circles about these points a little larger than the size of the holes to be drilled so that after drilling it may be seen if the hole is in the right position.

Holding the Work.—This exercise being small in comparison with the holes to be drilled, should be clamped to the table of the drill press, Fig. 37, or held in a drill vise, Fig. 38. When the former method is used, the work should be placed so that the drill is above one of the slotted holes in the table. The object in this is to avoid drilling into the table. In using the vise, the parallels should not be directly under the drill.

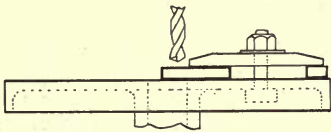

Fig. 37

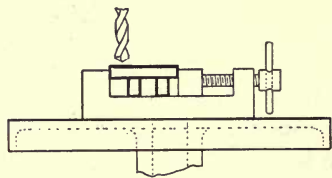

Fig. 38

If the holes were small, say less than $1/4$ inch, or the casting larger, it could be held by hand. In this case the work should rest on a piece of wood. Since the wood is soft the work is less liable to slip out of the hand than when placed on the smooth surface of the drill press table. The slipping does not usually occur until the point of the drill pierces through at the end of the hole. Then it will slip unless held firmly.

Selecting the Drill.—Drills are usually designated by their size and the shape of their shanks. The size refers to the diameter of the drill. The shank is the end of the drill by which it is held in the machine.

The common drill sizes as listed in most catalogues run from $1/16$ of an inch to 3 inches, varying by $1/64$ inch. The sizes usually found in shops, however, run about as follows: $1/16''$ to $1/2''$ by $1/64''$, $1/2''$ to $1''$ by $1/32''$, $1''$ to $2''$ by $1/16''$.

Drills are also made in number and letter sizes. The number sizes run from No. 1, which is $.2280$ in diameter, to No. 80, which is $.0135$ in diameter. There are 80 different sizes. The letter drills range from A, with a diameter of $.234$ inches, to Z, which is $.413$ in diameter, and are 26 in number.

The shank of the common drill is either straight or tapered. When straight it is held in the machine with a drill chuck.

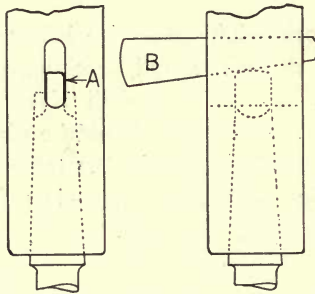

Fig. 39

Taper shank drills are held in the spindle as shown in Fig. 39. The tongue, or tang, of the drill, A, fits into a slot at the end of the hole in the spindle and makes the drill rotate with the spindle. The tapered shank keeps the drill from dropping out. To remove the drill from the spindle, a taper drift, B, is used as shown.

The advantages of the taper shank drill are that it runs true and is more conveniently held in the machine for large sized holes. Straight shank drills larger than $3/4''$ must be held in a chuck so large that it often interferes with the drilling.

In most shops drills up to $3/16''$ diameter are used with straight shanks and those from $3/16''$ to $3/4''$ in diameter with either straight or taper shanks. Drills larger than $3/4''$ in diameter usually have taper shanks.

Straight shank drills cost less than those with taper shanks and are therefore used whenever possible.

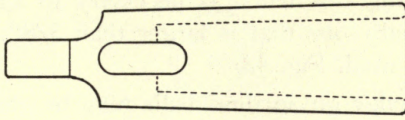

Fig. 40

The steel sleeve or bushing shown in Fig. 40 is used when the shank of a taper shank drill is smaller than the hole in the spindle of the machine. Sometimes when using small drills in a large machine it is necessary to use two or three of these sleeves.

After selecting the drill examine the edges. If they are dull sharpen them on the grinding wheel.

How the Drill Should Be Ground.—The common twist drill has two cutting edges A and B, Fig. 41. Like other tools these must be ground with clearance C in order to cut when the drill is forced into the metal and rotated as indicated by the arrow.

The cutting edges A and B should each make an angle of 59° with the axis of the drill. They should be of equal length in order to bring the point of the drill in the center. If the point is off center, only one edge of the drill will cut. This not only reduces its efficiency but also produces a hole larger than it is intended.

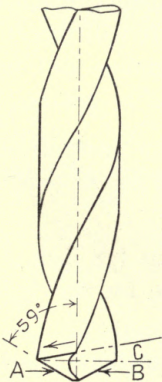

Fig. 41

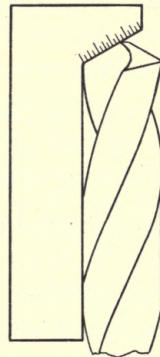

Fig. 42

There are two methods of sharpening a drill, by machine and by

hand. In shops where a great deal of drilling is required, a drill grinding machine is used.

Hand Grinding.—When it is necessary to sharpen a drill by hand, and especially one that is larger than $3/8''$, a drill grinding gauge should be used, Fig. 42.

The cutting edge on smaller drills may be gauged by eye. If the side of the grinding wheel is used instead of the periphery, it is easier to produce a good cutting edge.

Speed of Drill.—The speed of the drill depends upon its size, the material being drilled and the feed used.

The following table will give beginners some idea of the range of speeds for different sized drills made of carbon steel.

Diameter of Drill	Revolutions per minute		
	Soft Steel	Cast Iron	Brass
$1/8$	850	1190	1770
$1/4$	390	565	855
$3/8$	265	370	370
$1/2$	200	260	412
$3/4$	112	168	265

Machinists do not, as a rule, consult a table for drill speeds because the hardness of the material varies, and drilling machines are not usually calibrated for the spindle speeds. It will therefore require some practical experience before a beginner can properly determine the speeds for different sizes of drills.

Centering the Drill.—There are two common methods used for centering the drill in piece A. In either case the center punch mark must be enlarged to about $1/16$ inch in diameter.

The first method is to drill a small hole about $1/8$ inch in diameter and $3/16$ deep. This hole acts as a guide for the $1/2''$ drill and insures its being in the correct position.

In the second method a $1/2''$ drill is used to make a countersink in the work about $1/4''$ in diameter. If this countersink is not in the center of the circle, chip a small groove on the side that is farthest from it, as in Fig. 43, with a round nose chisel or center

gouge. Drill a little deeper and if the countersink still does not center, repeat the operation.



Fig. 43

In either method the drill must be centered before it cuts to its full size.

Laying Off Holes in Piece B.—After the holes have been drilled in piece A place it in position on B. With a scribe lay out the circles on B by marking through the holes in A.

Drilling Piece B.—The holes in piece B should be drilled a little larger than the diameter at the bottom of the threads of a $1/2''$ tap. This is $13/32$ of an inch.

Center punch the center of the circles as accurately as possible by eye. The drill should be centered by the second method described above.

Drilling a Fixed Depth.—The desired depth of hole may be obtained with the aid of the graduations on the spindle of the drill press. In case the spindle is not calibrated a mark may be made on it with a piece of chalk to indicate when the desired depth has been reached.

Tapping.—Clamp the work in the bench vise and tap the holes, first using a $1/2''$ plug tap, then a $1/2''$ bottoming tap.

The plug tap is started by pressing down on it and turning it with a wrench. After the tap has entered deep enough to cut a full thread, in this case about $5/16''$ deep, it is no longer necessary to press down on it as the tap will then draw into the work when turned.

Lard oil should be used for lubrication when tapping cast iron or steel. Brass is usually tapped dry.

The accuracy with which a hole is tapped depends upon the operator, as the tap will not follow the hole. The tap should therefore be started square with the face of the work. In some cases

this may be judged by eye, but it is usually necessary for beginners to use a square or the blade of a square, as in Fig. 44. In this case the blade is placed back of the tap and away from the hole. The tap is squared up by bringing its shank parallel with the edge of the blade. If the blade were placed over the edge of the hole, the small ridge produced by the tap would tip it out of square. The tap must be squared before it cuts to its full diameter as any attempt to straighten it after that is liable to break it.

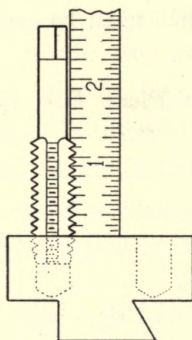

Fig. 44

As the plug tap is tapered at the end, it will not cut the full size of thread to the bottom of the hole. It is desirable on account of strength to have the length of the full threads greater than the diameter of the screw. The tapping should therefore be finished with a bottoming tap which will cut full threads nearly to the bottom of the hole.

The reason for not using the bottoming tap for the entire tapping operation is that it is practically impossible to start such a tap.

Filing Holes in Piece A.—In case the holes in piece B do not match up exactly with those in A, the screws will bind or will not go in at all. It is then necessary to file the holes in A with a round file until the screws no longer bind.

PART III.

MILLING MACHINE WORK

PARIS

PRINTING MACHINE WORKS

MILLING MACHINE WORK

There are several different kinds of milling machines, but the ones most commonly used are the plain miller and the universal miller. Both of these machines have horizontal spindles. The difference between them is that the table of the plain miller can be moved only at right angles or parallel to the spindle, while the table of the universal miller may be moved at different angles. The principal advantage of the universal machine occurs in cutting spiral gears, spiral milling cutters, etc. As this class of work will not be treated in this book only the plain milling machines will be considered.

As in the case of lathes there are several makes of millers, all of which, although varying in efficiency and utility, employ the same fundamental cutting operations. When one has become familiar with the operation of one machine, he should be able to operate other makes of different design with very little difficulty.

CONE-DRIVEN PLAIN MILLER

The plain miller shown in Fig. 45 has a three step cone drive with double back gears. The small pilot wheel, below the name and index plate, together with the two levers on either side of it are used for changing the feed. The double-ended V-shaped lever under the table is for starting and stopping the feed. The hand crank and hand wheels at the right are for the hand feeds and for raising and lowering the table.

HIGH-POWER PLAIN MILLER

Fig. 46 shows a plain miller in which the spindle speed changes are obtained by shifting encased gears near the driving pulley. This is done by means of the small pilot wheel and levers on the gear box below the name. The long hand lever at the right of this box operates the clutch for starting and stopping the machine.

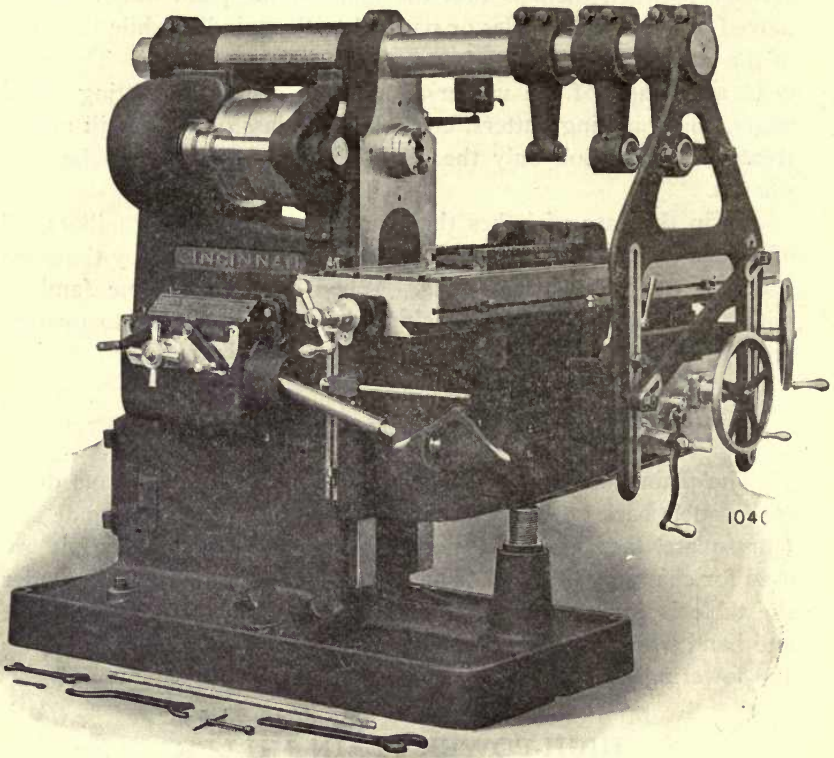

Fig. 45

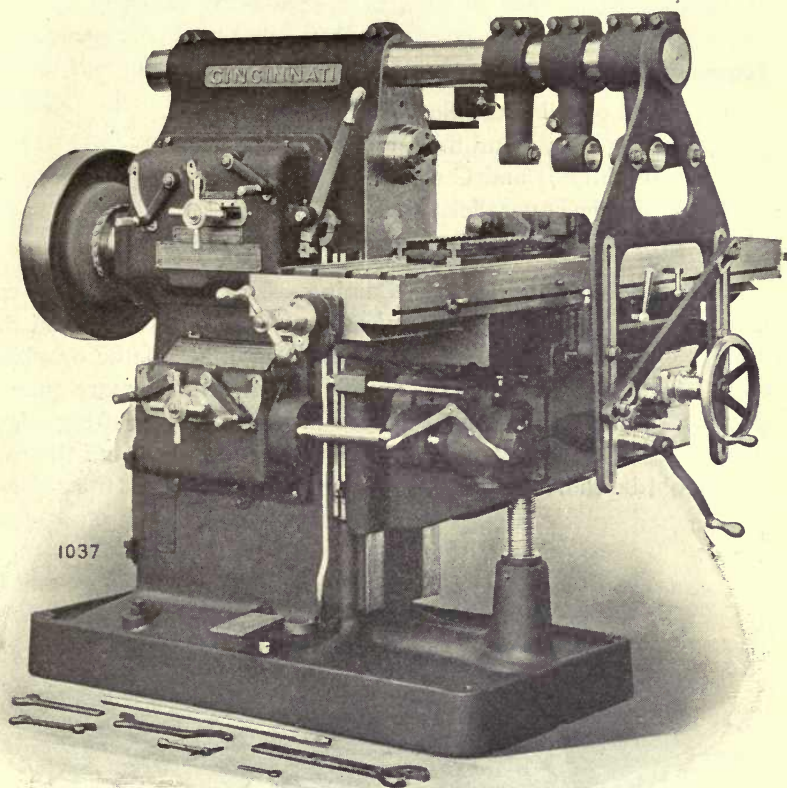

Fig. 46

EXERCISE NO. 8

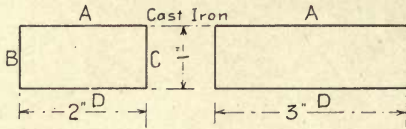

Fig. 47

Sequence of Operations :

1. Grind off all gates, fins, sand, etc.
2. Clamp in vise and mill side A.
3. Mill sides B and C square with A.
4. Mill side D parallel to A.
5. Mill both ends square with the other sides.

Object of Grinding Rough Casting.—The outer surface of cast iron is hard and more or less covered with sand. This would dull milling cutters even more quickly than it would a lathe or planer tool. As milling cutters are expensive and require more time to sharpen, greater care should be taken to protect their cutting edges. It is not necessary, however, to remove all of the scale, but the casting should be thoroughly cleaned.

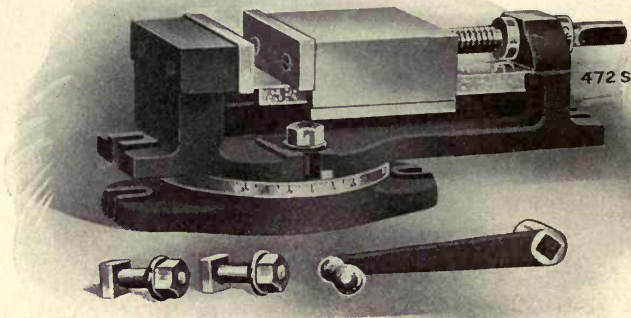

Fig. 48

Milling Machine Vise.—Fig. 48 shows the vise used in the mill-

ing machine. It has a graduated swivel base so that it can be turned at different angles.

Clamping the Work.—The work is held in the milling machine vise as shown in Fig. 49. It should rest on two parallels that are wide enough to bring the surface to be milled above the level of the vise. In order to get a tighter grip on it, heavy paper should be placed between it and the jaws of the vise. The paper will also protect the jaws from being marred by the rough sides of the casting.

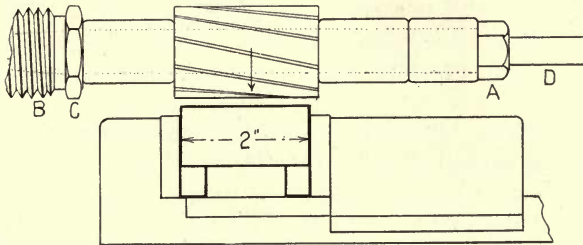

Fig. 49

The Cutter.—Work of this sort is milled with a common spiral milling cutter. As these cutters are made in different lengths, one should be selected that is a little longer than the widest surface to be cut.

The Arbor.—All milling machine arbors are provided with collars, Fig. 49, of different lengths, so that the position of a cutter on them may be varied. These collars slip loosely on over the arbor and when the nut A is tightened clamp the cutter in place.

If the cutter is mounted near the main bearing of the milling machine spindle, it will work better than if located near the outer end.

One end of the arbor is tapered and fits into the spindle B. It may be withdrawn by tightening the nut C. The end D is supported by an out port bearing.

Most arbors are also provided with a keyway so that when heavy cuts are to be taken or a large cutter used it may be keyed to the arbor.

Caution.—Beginners are cautioned to be sure that the direction of rotation and speed of the cutter and the direction of the feed are correct before starting a cut.

Direction of Cutter Rotation.—Milling cutters are all ground with clearance A, Fig. 50, and if rotated in the wrong direction will not cut. Therefore, before mounting the cutter start the machine and note the direction of rotation of the arbor. If it rotates as indicated by the arrow the cutter should be mounted as shown. If the cutter were mounted as in Fig. 51 it would not cut.

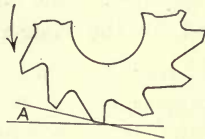

Fig. 50



Fig. 51

Cutter Speed.—The proper cutting or surface speed of a milling cutter made of carbon steel is about 60 to 70 feet per minute when cutting cast iron. Cutting speed is the velocity of a point on the circumference of the cutter. Thus a cutter 2 1/2 inches in diameter, and turning 90 revolutions per minute, will have a cutting speed of about 60 feet per minute.

No fixed rule can be given for the proper cutter speed as too much depends on the character of the work, the hardness of the metal, the size of the machines, etc. Machinists determine the proper speeds by the action of the cutting tool and from previous experiences on work similar in character.

It will be necessary for the instructor to designate the speed of the machine until the student has had sufficient practice to be able to judge fairly well for himself. It is better to run the cutter too slow than too fast, for if it is run too fast it will soon be ruined.

Direction of Feed.—The direction of the feed in relation to the cutter rotation is very important. Fig. 52 shows the correct way. In this case the direction of the feed is opposite to the rotation of the cutter. The wrong way is shown in Fig. 53. If the work were fed in this manner, the cutter would act as a feed roller and draw the work in faster than it would cut. This would break the teeth of the cutter.

Roughing Cut.—The roughing cut on cast iron should always be deep enough to get under the scale; in this case about 3/32 or 1/8 inch deep. Cast iron and brass are milled dry but on steel the cutter works better if lard oil or some other lubricant is used.

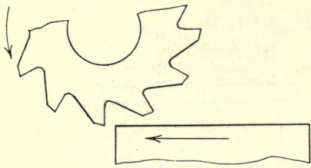

Fig. 52

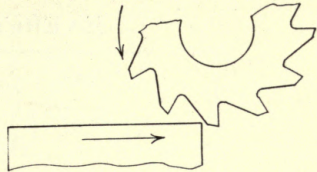

Fig. 53

Rate of Feed.—As in the case of the cutter speed no fixed rule can be given for the rate of feed. This should be determined by the instructor. It may be stated, however, that .018 of an inch feed per revolution of the cutter should be safe in this case. If a good machine is used and the iron is soft this feed could be increased.

Finishing Cut.—The depth of the finishing cut can be anything up to $1/32$ of an inch. If more than this is taken off, the surface may not be uniform. The same cutter speed as for roughing can be maintained but the feed should be increased. If a large surface is to be finished and the iron is soft it will pay, in the amount of time saved, to increase both the speed and the feed.

After side A, Fig. 47, is finished, the sides B and C are milled square with A. D is then milled parallel with A. The method of clamping the work in the vise is practically the same as that used for the shaper work.

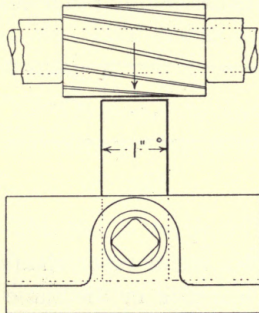

Fig. 54

Milling the Ends.—If, in milling the ends, the block extends so far above the jaws of the vise that the action of the cutter has a tendency to tip it, turn the vise through 90 degrees and clamp it edgewise as shown in Fig. 54.

EXERCISE NO. 9

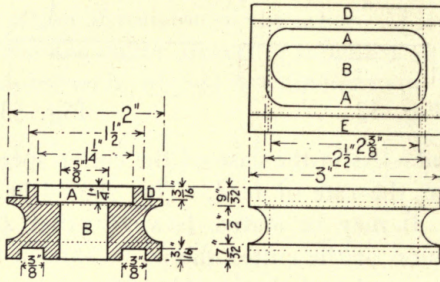

Fig. 55

Sequence of Operations:

1. Mill the recess A and the slot B with a $5/8''$ end mill.
2. Mill the corners D and E with a side milling cutter.
3. Mill the grooves in the bottom with a $3/8''$ milling cutter.
4. Mill the concave sides with a forming cutter.

Milling the Recess and Slot.—(Exercise No. 8 is to be used for this exercise.) The recess A and the slot B are good examples of the kind of work for which the end mill is particularly adapted. However, this tool is also used for other kinds of work.

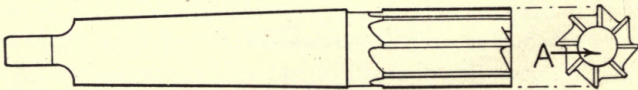

Fig. 56

The end mill, Fig. 56, has a taper shank and is mounted in the spindle of the milling machine in the same manner as a drill in a drill press. These shanks have either the Morse taper or the Brown and Sharp taper. The Morse standard taper is used for drills as well as for end mills. The taper of the Brown and Sharp standard is less than the Morse standard. For this reason the shanks of end mills used in milling machines usually have the Brown and Sharp taper as they will stay in the spindle better.

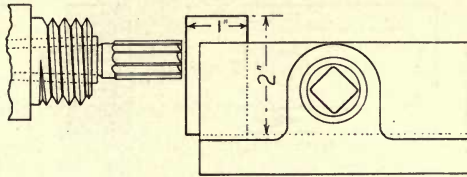

Fig. 57

Clamping the Work.—Lay off the outline of the recess on the surface of the block and clamp it square in the vise as in Fig. 57. Adjust the position of the block until the end of the mill is just touching the surface at one corner of the recess. In order to determine when the recess has been cut to the full depth, set the dial on the cross slide to the zero point. This dial is graduated in thousandths of an inch.

Depth of Cut.—Force the end of the mill into the surface for about .03 of an inch and feed the work by hand so that the mill will cut just inside of the outline marked. Repeat this operation until the cross-feed dial reads .250 of an inch, the required depth of the recess.

End mills usually work better with shallow cuts and coarse feeds than with deep cuts and fine feeds. Another reason for taking shallow cuts in this case is because there are no teeth at the center of the cutting end A, Fig. 56. This makes it hard to force the tool into the metal.

Speed of Cutter.—As this cutter is much smaller in diameter than the spiral mill used in exercise No. 8 the spindle speed may be increased.

Milling the Slot.—The slot is to be milled with the same end mill that was used for cutting the recess. Before starting this cut, remove the work from the vise and drill a 1/2 inch hole as shown at H, Fig. 58. This hole is necessary on account of the center of the end mill having no teeth.

After reclamping the work in the vise adjust it so that the mill will be at the end of the slot where the hole has been drilled. Feed the cutter through the block, Fig. 59, as far as the cutting edges will permit. It cuts better in this position than at the outer end.

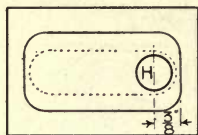

Fig. 58

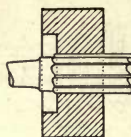

Fig. 59

Now feed the work horizontally until the cutter reaches the other end of the slot.

Rate of Feed.—If the automatic feed is used it should be very fine. The safest way for beginners is to feed it by hand. If too coarse a feed is used the cutter will break.

Direction of Feed.—When cutting a slot like this where half of the circumference of the mill is in contact with the metal and when using the end of the mill as in cutting the recess, the feed may be in either direction.

Gang Milling.—When two or more cutters are used on one spindle at the same time it is called gang milling. The corners E and D of this exercise may be milled by first cutting one and then the other with a side milling cutter. A simpler method would be to use two cutters, Fig. 60, with the collar I between them so that they will be the proper distance apart.

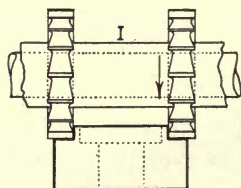

Fig. 60

A third method is to use a cutter between the side mills instead of a collar. If this method is used the surface should not be milled when squaring the block in exercise No. 8.

Depth of Cut.—When using gang cutters the required depth is usually cut at one time. To set the work for the depth shown in Fig. 55, bring the work up under the revolving cutter until it just touches. Then move the work clear of the cutter and raise it $\frac{3}{16}$ or .187 of an inch, using the graduated dial on the elevating shaft.

Cutting Speed.—The speed of the machine for gang cutting is determined by the diameter of the largest cutter.

Groove Cutting.—The two $3/8$ inch grooves in this exercise may be cut with one or two keyway cutters.

The difference between this cutter and the side milling cutter is that it has no cutting edges on the side. It is used principally for cutting grooves like these and for cutting standard keyways in shafts.

Forming Cutters.—Cutters having curved or irregular cutting edges are usually called formed cutters. The one used for the concave surface in this exercise might be classed as such, but is usually called a convex cutter.

When cutting the concave surface in the end of the block it will be less liable to slip if clamped edgewise in the vise.

DIVIDING HEAD AND TAILSTOCK

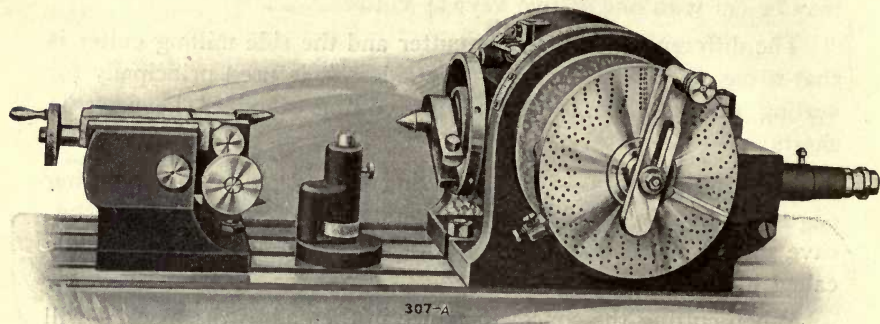

Fig. 61

Fig. 61 shows a dividing head and tailstock. The tailstock is used for holding the ends of shafts, mandrels, etc. The small jack shown is for supporting the middle of long slender work when mounted between the centers.

The Dividing Head.—The dividing head is used for accurately spacing or dividing the circumference of a piece of work into any number of parts, as in squaring a shaft, gear cutting, etc.

The center and slotted arm are made in one piece and like a lathe center are held in the spindle of the dividing head by a taper fit. The slot in the arm is to receive the tail of a lathe dog so that work mounted between the centers will rotate with the spindle of the dividing head. The set screw at the end of the slot is to take up the slack or lost motion between the sides of the slot and the tail of the lathe dog.

The spindle of the dividing head is threaded like a lathe spindle so that a chuck may be screwed on it.

The Index Plate.—The round plate with a number of circles of holes on the side of the dividing head is called the index plate.

Index Crank.—The index crank is in front of the index plate and is provided with a slot so that by loosening the hexagonal nut at the center it may be moved to different positions.

Index Pin.—At the end of the index crank is the index pin. One end of this pin is of such size that it just fits into the holes in the index plate. The other end has a knurled knob which is used to withdraw the pin so that the crank may be turned.

Indexing.—The shaft on which the index crank is mounted is geared to the spindle of the dividing head at a ratio of 40 to 1. Therefore, 40 turns of the crank will cause the spindle to make one complete revolution.

If it were desired to make 4 divisions, as in squaring a shaft, the number of turns of the crank would be $40 \div 4$, or 10 revolutions for each cut. To make 40 divisions as in a 40-tooth gear wheel the crank would be turned one revolution for each tooth.

In case 32 divisions are to be made, the turns of the crank per division would be $40/32$ or $1 \frac{1}{4}$ revolutions. To turn the crank $\frac{1}{4}$ of a revolution a circle of holes is selected that is evenly divided by 4 as 24, 36, etc. If the 24 hole circle is used, the crank should be turned 6 holes exclusive of the hole the index pin is in. Therefore to make one of the 32 divisions the index crank is turned 1 revolution plus 6 holes on the 24 hole circle.

The Sector.—All dividing heads are provided with a sector which eliminates counting the holes in the index plate each time a division is made.

By loosening the screw A, Fig. 62, the arms D and E may be adjusted to include any desired number of holes. Thus to turn the index crank $\frac{1}{4}$ of a revolution on a 24 hole circle the index pin should be rotated from B to C.

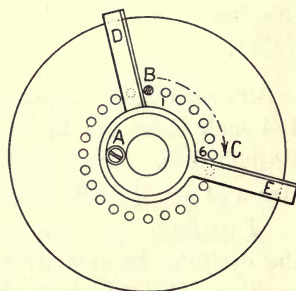

Fig. 62

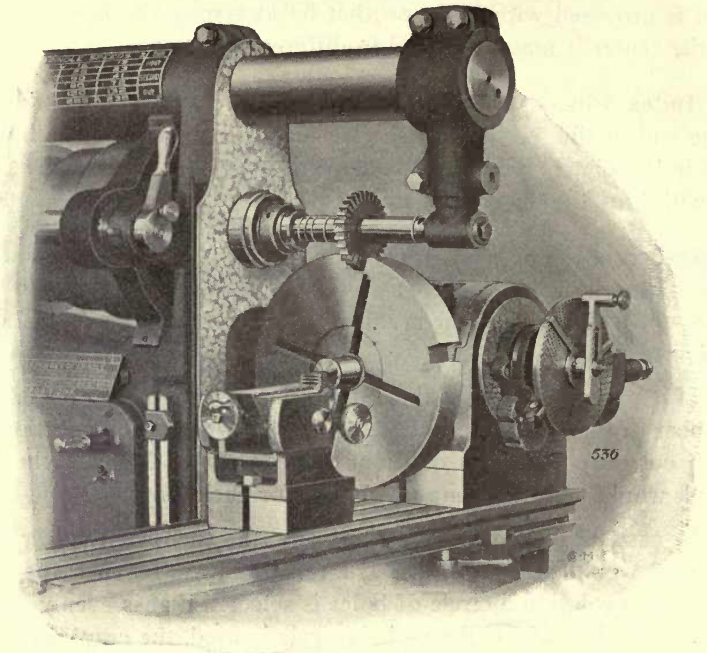

Fig. 63

Examples of Use for the Dividing Head.—Fig. 63 shows the method of cutting five equally spaced slots on the circumference of a circular plate. The latter is mounted on a mandrel such as is used in cutting gears. The method of supporting the outer end of this mandrel is clearly shown. The cutter used is a side cutting miller.

An example of accurate indexing is shown in Fig. 64. Thirty-six $\frac{1}{4}$ inch holes are to be equally spaced on the circumference of a 19-inch disc. They are first drilled with a short drill a little under size and are then finished to size with a $\frac{1}{4}$ -inch end mill.

This figure also shows the method of handling work larger than the dividing head will swing when the spindle is in the horizontal position. In this case the dividing head spindle has been turned through an angle of 90° .

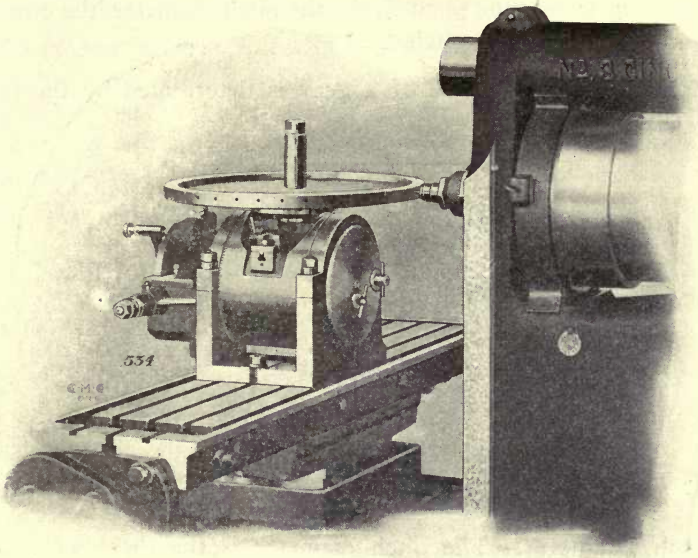

Fig. 64

SPUR GEARS AND RACK

Gears whose tooth elements are parallel with their axis are known as spur gears. They are also called straight faced gears.

There are several different systems of gear teeth outlines, but the one most commonly used is the involute system. This system requires only eight cutters for each pitch and has a wide application.

The operator of a milling machine should become familiar with the following terms: the pitch circle, the pitch diameter, the circular pitch and the diametral pitch.

Pitch Circle.—The size of a gear is determined by the pitch circle, C, Fig. 65.

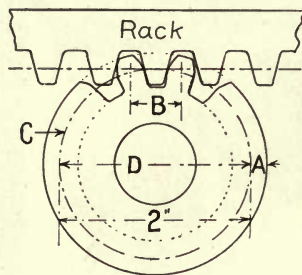

Fig. 65

Pitch Diameter.—The pitch diameter is the diameter of the pitch circle, D, Fig. 65.

Circular Pitch.—The circular pitch is the distance from the center of one tooth to the center of the adjoining tooth measured on the pitch circle, B, Fig. 65.

Diametral Pitch.—The diametral pitch is the number of teeth per inch of pitch diameter. It therefore determines the size of the teeth.

For example, a gear with 12 teeth and a pitch diameter of 2 inches will have a diametral pitch of 6. One with 16 teeth and the same pitch diameter will have a diametral pitch of 8. Of these two gears the teeth on the 16 tooth gear will necessarily be smaller than those on the 12 tooth gear.

The distance A, Fig. 65, is the reciprocal of the diametral pitch. Thus on an 8 diametral pitch gear, the distance A is $1/8$ of an inch.

The diametral pitch will hereafter be referred to as the pitch.

Shape of Tooth.—The thickness of the tooth on the pitch circle is the same in all sizes of gears having the same pitch. The shape of the tooth, however, varies with the size of the gear; that is, the curve on the side of a tooth on a 12 tooth gear is a little different from that on a gear having 13 teeth. The greatest contrast is noted between a 12 tooth gear and a rack, Fig. 65.

When gear wheels are cut in a milling machine a formed cutter having the same profile as the space between the teeth is used. If it were necessary to cut the teeth theoretically correct, a different cutter would be required for each different size gear. In practice, however, for the involute system only 8 cutters are used for each pitch. The following table gives the range of each cutter.

No. 1	will cut wheels from	135 teeth to a rack.
" 2	" " " "	" 55 " 134 teeth, inclusive.
" 3	" " " "	" 35 " 54 " "
" 4	" " " "	" 26 " 34 " "
" 5	" " " "	" 21 " 25 " "
" 6	" " " "	" 17 " 20 " "
" 7	" " " "	" 14 " 16 " "
" 8	" " " "	" 12 " 13 " "

For example, if it is desired to cut a 10 pitch gear with 28 teeth, a 10 pitch, number 4 cutter should be used.

Rack.—The teeth of a rack are developed along a straight line and mesh with a gear having the same pitch.

EXERCISE NO. 10

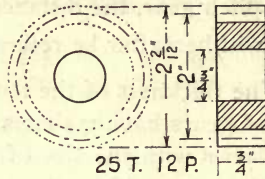

Fig. 66

GEAR CUTTING

Sequence of Operations:

1. Select cutter and mount on milling machine arbor.
2. Line up center of cutter with center of the dividing head.
3. Place gear blank on mandrel and mount mandrel between centers of the dividing head and the tail stock.
4. Set cutter to proper depth.
5. Set the index crank and sector on dividing head for 25 divisions.

Selecting Cutter.—The number of teeth to be cut in this gear is 25. Referring to the table on page 53 it is seen that a number 5 cutter has the proper range.

Mounting Cutter.—The cutter is mounted on the milling machine arbor as close to the main bearing of the spindle as possible and yet far enough away to have it line up with the center of the dividing head.

Centering Cutter.—In order to cut the teeth radially the center of the cutter must be in line with the center of the dividing head. All gear cutters are marked with a center line so that by moving the dividing head close to the cutter and adjusting the position of the table they may be accurately centered.

Placing Gear on Mandrel.—Gear blanks are usually mounted on a gear mandrel, Fig. 67.

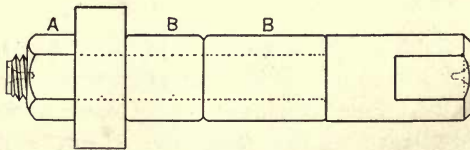

Fig. 67

This mandrel is not tapered, the clamping being done by means of the nut A. By removing the collars B B several gears can be mounted at one time.

Mounting the Gear Mandrel.—A milling machine dog or a lathe dog is fastened on one end of the mandrel. The latter is then mounted between the dividing head center and the tail stock center in very much the same manner as is shown in Fig. 63. Oil should be used on the tail stock center. The set screw in the slotted arm of the dividing head is screwed against the tail of the dog to prevent any lost motion.

Depth of Cut.—When cutting gear teeth of this size all of the stock is removed at one cut. For gears with large teeth, say of 4 or 5 pitch and larger, it may be necessary to take two cuts.

To set the work so that the cutter will cut the proper depth start the machine and raise the work up under the revolving cutter until it just touches. Move the work clear of the cutter and set the dial on the elevating shaft to zero. Now raise the table .180 of an inch as indicated by the graduations on the dial. This is the proper depth for a 12 pitch gear tooth.

All milling machines are provided with a chart that gives the depth to be cut and the range of the cutters for all sizes of gears. This side of each cutter is also marked with this information for its particular pitch and range.

Setting the Index Crank.—There is a clamping nut on the side of the dividing head opposite the index plate which should always be loosened before turning the index crank and tightened after indexing. In order to index 25 teeth, the crank must be turned $1/25$ of 40, or $1\frac{3}{5}$ turns per tooth. $3/5$ of a revolution can be measured on a circle of holes which is a multiple of 5 as 20, 25, 30, 35, etc. Assuming the use of the 30 hole circle, $3/5$ of a revolution will be represented by 18 spaces.

Loosen the nut B, Fig. 68, and adjust the index pin C in one of the holes of the 30 hole circle. Now tighten the nut B just enough to hold the crank in position and pull out the index pin to see if it will drop into the hole without binding. If the index pin is not in line with the hole its position may be changed slightly by rapping the end of the index crank with a piece of wood. If a light rap is not sufficient loosen the nut a little. After the index pin is properly set, tighten the nut B so that it will stay in this position.

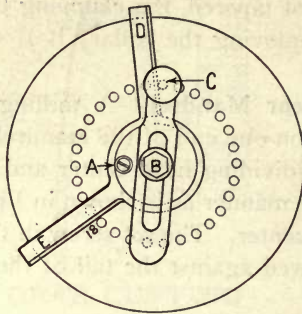

Fig. 68

Setting the Sector.—Loosen the clamping screw A on the sector, Fig. 68, and move the arm D so that the beveled edge rests against index pin C. Withdraw the index pin and turn the crank to the right 18 holes, not counting the hole the pin was in. Without changing the position of the arm D move the other arm E until its beveled edge strikes the index pin in its new position at the 18th hole. Tighten the screw A. The sector is now set to include $\frac{3}{5}$ of a turn, or 18 spaces.

Indexing.—Before taking the first cut, turn the index crank clockwise one complete revolution. This will take out all the slack or lost motion in the dividing head.

To index the gear for the next cut rotate the sector arm D up to the index pin. Withdraw the pin and give the crank one turn to the right or clockwise, plus the fraction of a turn included between the sector arms. This operation is repeated until the gear is finished.

Cutting a Rack.—The size of the teeth of a rack, as with spur gears, is designated by the pitch.

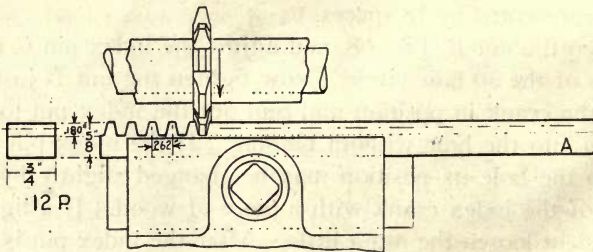

Fig. 69

To space the teeth it is necessary to know the distance from the center of one tooth to the center of the adjoining one. For a 12 pitch rack this is the same as the circular pitch of 12 pitch spur gears. The circular pitch is obtained by dividing 3.1416 by the diametral pitch. With a diametral pitch of 12 the circular pitch is .262". The following table gives the diametral pitches commonly used and the corresponding circular pitches.

Diametral Pitch	Circular Pitch	Diametral Pitch	Circular Pitch
1¼	2.5133"	10	.314
1½	2.0944	11	.286
1¾	1.7952	12	.262
2	1.571	14	.224
2¼	1.396	16	.196
2½	1.257	18	.175
2¾	1.142	20	.157
3	1.047	22	.143
3½	.898	24	.131
4	.785	26	.121
5	.628	28	.112
6	.524	30	.105
7	.449	32	.098
8	.393	36	.087
9	.349	40	.079
		48	.065

Clamp the rack blank in the milling machine vise on a parallel as shown in Fig. 69. After taking the first cut of the required depth, set the dial on the cross feed to zero. Move the table horizontally .262" as indicated by the dial on the hand crank. Take another cut and continue this operation until the rack is finished. If one end of the rack, as A, extends beyond the vise, it will be necessary to reset the work as the cutter will not cut satisfactorily with such poor support.

It is to be noted that it is necessary to know the distance from the center of one tooth to the center of the following one. For a 12-tooth gear this is the case as the circular pitch of 12 teeth and 1 inch is the circular pitch obtained by dividing 1 inch by the number of teeth. With a diametral pitch of 12 the circular pitch is 1 inch. The following table shows the theoretical pitches for gears of 12 teeth and 1 inch diameter.

Number of Teeth	Circular Pitch	Diametral Pitch
12	1.0000	12.0000
11	1.1071	11.0000
10	1.2571	10.0000
9	1.4143	9.0000
8	1.5708	8.0000
7	1.7361	7.0000
6	1.9105	6.0000
5	2.0944	5.0000
4	2.2872	4.0000
3	2.4899	3.0000
2	2.7000	2.0000

The following table shows the theoretical pitches for gears of 12 teeth and 1 inch diameter. It is to be noted that it is necessary to know the distance from the center of one tooth to the center of the following one. For a 12-tooth gear this is the case as the circular pitch of 12 teeth and 1 inch is the circular pitch obtained by dividing 1 inch by the number of teeth. With a diametral pitch of 12 the circular pitch is 1 inch. The following table shows the theoretical pitches for gears of 12 teeth and 1 inch diameter.

UNIVERSITY OF CALIFORNIA LI

This book is DUE on the last date stamp

Fine schedule: 25 cents on first day over

50 cents on fourth day over

One dollar on seventh day

ENGINEERING LIBRARY

JAN 13 1948

MAY 21 1948

FEB 28 1951

MAR 15 1951

LD 21-100m-12,'46(A2012s16)4120

104

735782 TJ1160

P3

Engineering
Library

UNIVERSITY OF CALIFORNIA LIBRARY

