

EX LIBRIS



THE ELEMENTS OF GRAPHIC STATICS

AND OF GENERAL GRAPHIC METHODS

BY

Brown

WILLIAM LEDYARD CATHCART

MEMBER AMERICAN SOCIETY OF NAVAL ENGINEERS, SOCIETY OF
NAVAL ARCHITECTS AND MARINE ENGINEERS, THE FRANKLIN
INSTITUTE, AMERICAN SOCIETY OF MECHANICAL ENGINEERS

AND

J. IRVIN CHAFFEE, A.M.

PROFESSOR OF MATHEMATICS
WEBB'S ACADEMY OF NAVAL ARCHITECTURE AND MARINE ENGINEERING
MEMBER SOCIETY OF NAVAL ARCHITECTS AND MARINE ENGINEERS

WITH 159 ILLUSTRATIONS



NEW YORK
D. VAN NOSTRAND COMPANY

23 MURRAY AND 27 WARREN STREETS

1910

TG270
C3

COPYRIGHT, 1910, BY
D. VAN NOSTRAND COMPANY.

THE
D. VAN NOSTRAND COMPANY

Norwood Press
J. S. Cushing Co. — Berwick & Smith Co.
Norwood, Mass., U.S.A.

PREFACE

THIS book is an extension of a course of lectures prepared originally by the authors for students of marine and mechanical engineering and naval architecture in their classes at Webb's Academy and Columbia University.

Graphical methods have had their widest application in the analysis of the stresses in stationary structures, and therefore the majority of the text-books on this subject have been written for civil engineers. For the use of students of mechanical and marine engineering, and as of possible service to engineers in those professions, this book gives a brief review of the principles of graphics and their application both to framed structures and to mechanism. The text has been illustrated fully by diagrams; occasional references have been furnished to sources of additional information; the principles of Applied Mechanics and of Strength of Materials which are involved in graphic processes have been discussed where necessary; and numerous problems have been assigned to test the students' knowledge of the subject.

The authors desire to acknowledge their indebtedness to the works of the pioneers in this science—Culmann, Hermann, Cremona, and Reuleaux—whose methods have been freely used.

NEW YORK, July 1, 1910.

CONTENTS

CHAPTER I

	PAGE
GRAPHIC ARITHMETIC	I
Art. 1. Definitions — 2. Graphic Arithmetic — 3. Addition and Subtraction — 4. Multiplication — 5. Division — 6. Multiplication by Ratios — 7. Powers — 8. Roots.	

CHAPTER II

GRAPHIC MEASUREMENT OF AREAS	15
Art. 9. Triangular Areas — 10. Quadrilateral Areas — 11. Areas of Polygons having More than Four Sides — 12. Areas of Figures whose Peripheries are partially or wholly Curvilinear.	

CHAPTER III

FORCES: CONCURRENT; NON-CONCURRENT, NON-PARALLEL	23
Art. 13. Definitions — 14. Parallelogram of Forces; Composition and Resolution of Forces — 15. The Force Triangle — 16. The Force (Vector) Polygon — 17. The Force Polygon is essentially the Graphic Addition of Forces — 18. The Force Polygon as applied to Non-concurrent Forces — 19. Jointed Frame in Equilibrium under the Action of External Forces — 20. The Equilibrium (Funicular or Cord) Polygon — 21. Resultant of Complanar, Non-concurrent Forces — 22. Equilibrium of Complanar Forces.	

CHAPTER IV

PARALLEL FORCES; COUPLES; CENTRE OF GRAVITY	40
Art. 23. Force Polygon for Parallel Forces — 24. Equilibrium of Parallel Forces — 25. Composition and Resolution of Parallel Forces — 26. Parallel Forces Equal in Magnitude and with Lines of Action at Equal Distances Apart — 27. Couples — 28. Centroid; Centre of Gravity — 29. Centre of Gravity of a Line — 30. Centre of Gravity of Polygonal Areas — 31. Centre of Gravity of Curvilinear Areas — 32. Centre of Gravity of Compound Areas — 33. Centre of Gravity of Partial Areas — 34. Centre of Gravity of Irregular Areas.	

CHAPTER V

	PAGE
MOMENTS	63
Art. 35. Moment of a Force with Respect to a Point — 36. Moments of Complanar, Non-parallel Forces with Respect to a Point — 37. Moments of Complanar, Parallel Forces with Respect to a Point — 38. Moment of a Couple with Respect to Any Point in its Plane — 39. Moment of the Resultant of Any System of Complanar Forces — 40. Conditions of Equilibrium — 41. Bending Moment — 42. Combined Bending Moments — 43. Moment of a Force with Respect to an Axis — 44. Moment of an Area with Respect to an Axis in its Plane; Centre of Gravity — 45. Moment of Inertia; Radius of Gyration — 46. Moment of Inertia of a System of Complanar, Parallel Forces — 47. Moment of Inertia of an Area — 48. Higher Moment Surfaces; the n th Moment of an Area — 49. Twisting Moment; Polar Moment of Inertia — 50. Twisting and Bending Moments Combined.	

CHAPTER VI

THE FUNDAMENTAL THEORY OF BEAMS	100
Art. 51. Definitions — 52. Fundamental Laws of Tension and Compression — 53. Elasticity — 54. Reactions at the Supports — 55. The Vertical Shear — 56. Shear Diagrams — 57. The Bending Moment — 58. Relation between Bending Moment and Vertical Shear — 59. Maximum Bending Moment — 60. Internal Stresses and External Forces — 61. Neutral Surface and Neutral Axis — 62. Shearing Force and Bending Moment — 63. The Elastic Curve.	

CHAPTER VII

FUNDAMENTAL THEORY OF BEAMS (<i>Continued</i>)	124
Art. 64. Relation of Curves of Load, Shear, and Bending Moment — 65. Relation of Curves of Bending Moment, Slope, and Deflection — 66. Stress Curves — 67. Deflection Curves for Simple Beams. — 68. Graphic Method of constructing the Deflection Curve — 69. Deflection Curves for Overhanging and Restrained Beams — 70. Stiffness — 71. Influence Diagrams — 72. Influence Diagram for Bending Moments due to a Single Moving Load — 73. Influence Diagram for Bending Moments due to a Uniform Moving Load — 74. Influence Diagram for Bending Moments due to a Series of Concentrated Loads — 75. Influence Diagram for Shears due to a Single Moving Load — 76. Influence Diagram for Shears due to a	

Uniform Moving Load—77. Influence Diagram for Shears due to a Series of Concentrated Loads—78. Influence Diagrams for the Left Reaction.

CHAPTER VIII

FRAMED STRUCTURES: ROOF TRUSSES; BRACED CANTILEVERS 146

Art. 79. Assumptions in the Analysis of Framed Structures—80. Definitions—81. Notation—82. Methods of determining Stresses—83. Roof Trusses: Definitions; Loads—84. Determination of Dead- and Snow-load Stresses—85. Wind Pressure on Roofs—86. Determination of Wind-load Stresses—87. Maximum and Minimum Stresses—88. Method of Substitution—89. Braced Cantilevers—90. Cranes—91. Accuracy in Drawing; Check on Results.

CHAPTER IX

BRIDGE TRUSSES 176

Art. 92. Bridge Trusses: Definitions—93. Loads on Bridge Trusses—94. Determination, by Stress Diagrams, of the Stresses due to Dead Loads and to Uniform Live Loads, Panels not Counterbraced—95. Intersections; Lattice Girders—96. Relation of Bending Moment and Chord Stress—97. Relation of Vertical Shear, Web Stresses, and Chord Increment—98. Stresses in Diagonals—99. The Chord Increment—100. Stresses in Verticals—101. Determination of Dead-load Stresses by the Force and Equilibrium Polygons—102. Live-load Shear; Maximum Shear—103. Counterbracing—104. Maximum Moments—105. Determination of Live-load Stresses in Web Members by Stress Diagrams—106. Determination of Live-load Stresses due to Locomotive Wheel Loads—107. Trusses with Inclined Chords—108. Plate Girders.

CHAPTER X

THE GRAPHICS OF FRICTION 228

Art. 109. Efficiency of Mechanism—110. Friction—111. Laws of Sliding Friction—112. Coefficient of Friction—113. Friction of Horizontal Plane Surfaces; Cone of Resistance—114. Wedge Friction—115. Friction of Screw-threads—116. Pivot Friction—117. Collar Friction—118. Journal Friction—119. Friction Circle—120. Friction of Link Connections—121. Chain Friction—122. Ropes: their Internal Friction and Resistance in Bending—123. Friction of Spur-gear Teeth—124. Belt Friction—125. Rolling Friction—126. Examples.

CHAPTER XI

	PAGE
MOMENT DIAGRAMS FOR SHAFTING	269
Art. 127. Shear and its Resultant Stresses — 128. Torsion —	
129. Torsion and Bending Combined — 130. Axles — 131. Shafts	
for Power Transmission — 132. Shaft with Single Overhung Crank	
— 133. Shaft with Single Crank, Overhung and Offset — 134. Cen-	
tre-crank Shaft — 135. Centre Cranks, Offset — 136. Double Crank	
Shaft.	
INDEX	305

GRAPHIC STATICS

CHAPTER I

GRAPHIC ARITHMETIC

1. **Definitions.** *Force* is an action between two bodies which causes, or tends to cause, change in their relative rest or motion and in their form. In its effect upon a body, a force should be considered with regard to its point of application to the body, its magnitude, and its direction.

A *rigid body* is a solid whose change of form, under the action of external forces, may be considered, in static and kinetic analyses, as negligible. No body, subjected to the action of such forces, is absolutely without change of form.

Equilibrium. When a body under the action of external forces is not undergoing sensible change of form, it is considered to be in either *static* or *kinetic equilibrium*.

In *static equilibrium*, the body, under the action of external forces, is either at rest or moving with uniform velocity (equal spaces in equal times) in a straight line. In *kinetic equilibrium*, the body is in motion and the velocity is not uniform, but accelerated, the word *acceleration* denoting any change—increase or diminution—in the velocity.

Statics treats of the principles and problems relating to bodies in *static equilibrium*. The subject includes, therefore, only the treatment of *balanced forces*. When a body, under the action of external forces, is at rest, it is apparent that the forces must exactly balance each other. Again, if this body be in uniform motion in a straight line, the same condition as to

equilibrium must prevail. Thus, when a railway car moves at constant speed on a straight track, the external forces which act on it—the forward pull of the car in front, the backward drag of the car in rear, the friction of the rails, the resistance of the air, the weight of the car acting downward, and the corresponding upward pressure of the rails—must exactly balance each other in order to maintain a uniform speed of the car.

Graphic statics covers the same field, but the algebraic analyses used in statics are replaced wholly by geometrical constructions. Its methods are fundamentally simple, since, for example, it is possible to represent the magnitude, direction, and point of application of a force by the length, inclination, and position of a straight line. Through the employment of graphic processes, there are thus obviated wholly the intricate and laborious computations which, in many cases, would otherwise be required.

2. Graphic Arithmetic. Graphic arithmetic treats of the employment of graphic methods in arithmetical calculations. In its general application to the computation of values of any character, it does not form a part of Graphic Statics proper; in its special uses in calculations relating to forces, it is, however, an essential branch of that science.

In graphic arithmetic, all computations are made by the use of lines, the magnitudes of the quantities being measured by the lengths of these lines. The lines may designate abstract numbers only, as 2, 33.5, 100, etc., or may represent quantities of any character, as pounds, dollars, cubic feet, etc., if the same unit of quantity be used throughout the calculation. Any convenient unit of length may be used to represent a unit of quantity, and the length of the line representing a given quantity will, therefore, be proportional to the number of units of quantity which the given quantity contains. Thus, if the scale be 0.1 inch = 1 pound, then 37 pounds will be represented by a line 3.7 inches long.

3. Addition and Subtraction. The methods of these operations are self-evident. Thus, to add 25 pounds and 7.5 pounds on a scale of 0.1 inch = 1 pound, lay off, in Fig. 1, $AB = 25$ lbs. = 2.5 in., and $BC = 7.5$ lbs. = 0.75 in.; then, $AC = 3.25$ in. = 32.5 lbs. is the sum required.

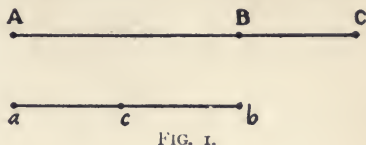

FIG. 1.

Similarly, to subtract 7.5 pounds from 25 pounds, lay off $ab = 25$ lbs. = 2.5 in. and from b set off $bc = 7.5$ lbs. = 0.75 in.; then, $ca = 1.75$ in. = 17.5 lbs. is the remainder required.

4. Multiplication. The methods used in this operation are based on the properties of similar triangles. These triangles are *mutually equiangular*. Thus, in Fig. 2, the triangles ABC and DEF will be similar if the angle $A =$ angle D , angle $B =$ angle E , and angle $C =$ angle F .

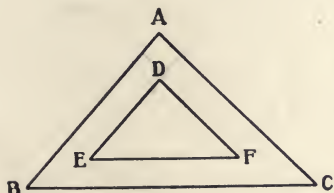

FIG. 2.

Again, the triangles ABC and DEF will be similar, if their *corresponding sides are proportional*, i.e., if:

$$AB : DE :: BC : EF :: CA : FD.$$

Further, these triangles will be similar, if they have *an angle in each equal and the including sides proportional*, i.e., if the angle $B =$ angle E , and also if:

$$BA : ED :: BC : EF.$$

Finally, they will be similar, if their *sides are parallel each to each or perpendicular each to each*, i.e., if $DE, EF,$ and FD are parallel or perpendicular to $AB, BC,$ and CA , respectively.

In graphic multiplication, we are required to find a line of length $x = a \times b, a \times b \times c,$ etc., which shall represent, on the

given scale, the product of two or more quantities, also represented on the same scale by lines of length a , b , c , etc. This operation may be performed graphically in a number of ways; the following general cases will suffice.

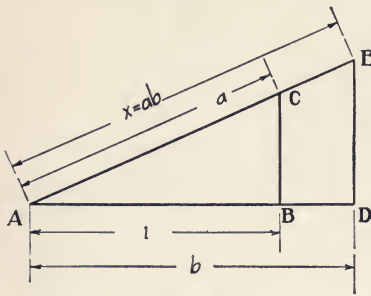

FIG. 3.

(a) Two factors, a and b , each greater than unity. In Fig. 3, lay off $AB = 1$; at B draw BC perpendicular to AB ; from A lay off $AC = a$, meeting BC at C ; on AB prolonged set off $AD = b$; from D erect DE meeting AC prolonged at

E . Then, $AE = x = a \times b$, since the triangles ABC and ADE are similar and:

$$AE : AC :: AD : AB, \text{ or}$$

$$x : a :: b : 1.$$

$$\therefore x = ab.$$

Thus, if $a = 1.25$, $b = 1.5$, $x = 1.875$. It will be observed that the fundamental principle of the method is to construct two similar triangles, one of which has a side whose length = 1.

(b) Two factors, a and b , each less than unity, Fig. 4. The method is the same as that in (a), except that DE is inclined toward A , and, since b is less than unity, DE is within the triangle ABC although still parallel to BC . The triangles ABC and ADE are similar and:

$$AE : AC :: AD : AB, \text{ or}$$

$$x : a :: b : 1.$$

$$\therefore x = ab.$$

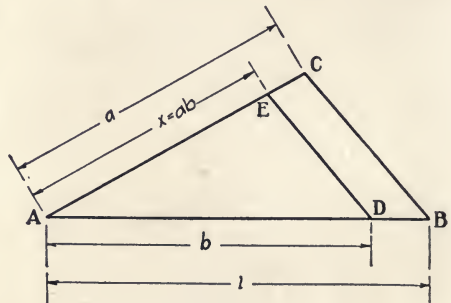

FIG. 4.

(c) Three factors, a , b , and c , so that the product $y = abc$. The method in this case is simply an extension of those given previously. Thus, in Fig. 5, find as in (a) the product $AE = x = ab$, and use it as a single factor for the final product $y = ab \times c$. Lay off $AD' = AE$; prolong BC to BC' , meeting $AC' = c$ at C' ; draw the perpendicular $D'E'$ meeting AC' prolonged at E' . Then, the triangles ABC' and $AD'E'$ are similar and $AE' = y = abc$.

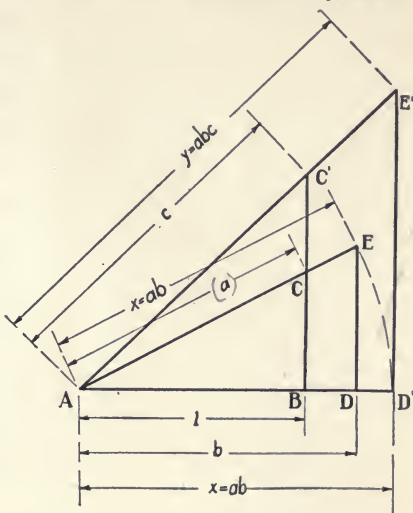

FIG. 5.

5. Division. Dividing a by b is the same as multiplying a by $1/b$. Hence, we must construct similar triangles from which may be derived the equation :

$$x = a \times 1/b = a/b,$$

found from the proportion :

$$x : 1 :: a : b,$$

which is the same as that in Art. 4 (a), except that the order is different, showing that the position of the sides, a and x , must be changed. In Fig. 6, lay off $AB = 1$; at B erect a perpendicular meeting the denominator, $b = AD$, at D ; prolong AD to C , making $AC =$ the numerator a ; from C let fall the perpendicular CE parallel to BD . Then, the triangles ABD and AEC are similar and $AE = x$, for :

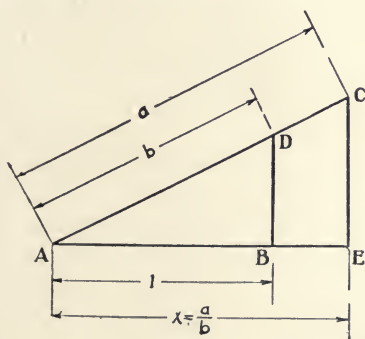

FIG. 6.

pendicular meeting the denominator, $b = AD$, at D ; prolong AD to C , making $AC =$ the numerator a ; from C let fall the perpendicular CE parallel to BD . Then, the triangles ABD and AEC are similar and $AE = x$, for :

Evidently the operation is, in general, a combination of those shown in Figs. 3 and 6. Thus, in Fig. 7, construct the lines $AE = a \times c$ and $AE' = b \times d$, by the methods shown in Fig. 3. Then, revolve the line AE' until it meets at C'' the line BCC'' prolonged; lay off $AE'' = a \times c$ on AC'' prolonged; from E'' drop the line $E''D''$ parallel to BC'' . Then, the triangles ABC'' and $AD''E''$ are similar and:

$$AD'' : AB :: AE'' : AC'', \text{ or}$$

$$x : 1 :: ac : bd.$$

$$\therefore x = ac/bd.$$

As drawn, the lines a, b, c, d have a value greater than unity. The diagram may be readily modified, by methods given previously, to provide for smaller values in any case.

7. Powers. To find the power of a number by graphical arithmetic the method of similar triangles may be again used.

Thus, in Fig. 3, if $b = a$, then $AE = a \times b = a^2$; similarly, in Fig. 5, if $c = b = a$, then $AE' = a \times b \times c = a^3$.

(a) Figure 8, based on this principle, gives a simple construction for finding a line representing the required power of a quantity indicated by a given line of length a . In this figure, $AB = 1$ is laid out on a horizontal line and a perpendicular BC is erected from B to meet

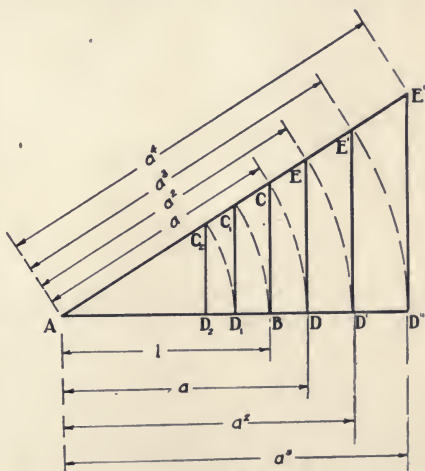

FIG. 8.

$AC = a$ drawn from A ; AC is then revolved to AD in AB prolonged and the perpendicular DE erected meeting AC pro-

longed at E . Then, the triangles ABC and ADE are similar and:

$$\begin{aligned} AE : AD &:: AC : AB, \text{ or} \\ AE : a &:: a : 1. \\ \therefore AE &= a^2. \end{aligned}$$

The triangle $AE'D'$ is constructed in the same way by revolving AE to AD' and erecting the perpendicular $D'E'$. The triangles ABC and $AD'E'$ are similar and:

$$\begin{aligned} AE' : AD' &:: AC : AB, \text{ or} \\ AE' : a^2 &:: a : 1. \\ \therefore AE' &= a^3. \end{aligned}$$

A similar construction will give the negative powers of a , *i.e.*, $a^{-1} = 1/a$, $a^{-2} = 1/a^2$, etc.; thus, in Fig. 8, revolve AB to AC_1 and drop the perpendicular C_1D_1 . Then:

$$\begin{aligned} AD_1 : AC_1 &:: AB : AC, \text{ or} \\ AD_1 : 1 &:: 1 : a. \\ \therefore AD_1 &= 1/a = a^{-1}. \end{aligned}$$

Again, revolve AD_1 to AC_2 and drop the perpendicular C_2D_2 . Then:

$$\begin{aligned} AD_2 : AC_2 &:: AB : AC, \text{ or} \\ AD_2 : 1/a &:: 1 : a. \\ \therefore AD_2 &= 1/a^2 = a^{-2}. \end{aligned}$$

This construction is convenient and compact, but it is limited to values of a which are greater than unity.

(*b*) The spiral polygon, with a constant angle of 90° between each pair of consecutive sides, is a construction which has been applied* in the graphical computation of powers and which is suitable for any value of a , greater or less than unity.

* Reuleaux, "The Constructor," Suplee's translation, Philadelphia, 1893, p. 25. Von Ott, "Grundzüge des graphischen Rechnens und der graphischen Statik," Prague, 1871, p. 10.

To construct this polygon, draw, in Fig. 9, the axes $X'OX$ and YOY' at right angles; on OX' lay off $OB = 1$; on OY set off $OA = a$, whose

value in this case will be taken as less than 1; from A draw $A2$, at right angles to AB and meeting OX at 2 . Then, the triangles OBA and $OA2$ are similar and:

$$O2 : OA :: OA : OB,$$

or $O2 : a :: a : 1.$

$$\therefore O2 = a^2.$$

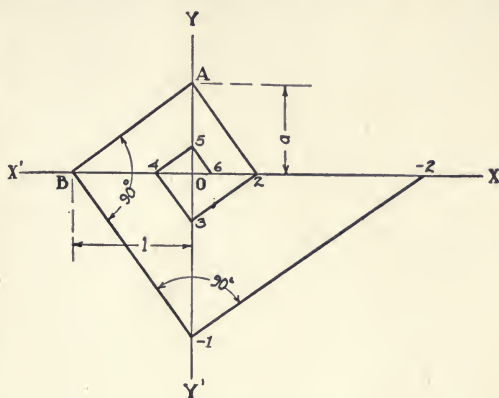

FIG. 9.

Again, draw $2, 3$ at right angles to $A2$ and meeting OY' at 3 . Then, the triangles OBA and $O2, 3$ are similar and :

$$O3 : O2 :: OA : OB, \text{ or}$$

$$O3 : a^2 :: a : 1.$$

$$\therefore O3 = a^3.$$

Continuing this process, we find the succeeding positive powers of a , the even powers on the axis $X'OX$, and the odd powers on the axis YOY' .

To find the negative powers of a , the spiral polygon is continued in the opposite direction from B . Thus, draw the line, $B, -1$, at right angles to AB and meeting OY' at -1 . Then, the triangles OBA and $O, -1, B$ are similar and :

$$O, -1 : OB :: OB : OA, \text{ or}$$

$$O, -1 : 1 :: 1 : a.$$

$$\therefore O, -1 = 1/a = a^{-1}.$$

Again, the triangles OBA and $O, -2, -1$ are similar and :

$$O, -2 : O, -1 :: OB : OA, \text{ or}$$

$$O, -2 : 1/a :: 1 : a.$$

$$\therefore O, -2 = 1/a^2 = a^{-2}.$$

For a value of a which is greater than unity, the construction of the spiral polygon is similar to that already given, the only difference being that the spiral expands with positive, and contracts with negative, powers.

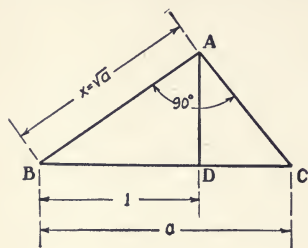

FIG. 10.

8. Roots. (a) The square root, fourth root, eighth root, etc., can be readily obtained by similar triangles. Thus, Fig. 10, if it is desired to find the square root of a quantity, a , greater than unity, lay off $BD = 1$, and, on BD prolonged, $BC = a$; and, erect the perpendicular DA , and,

from A as a vertex, draw the lines AB and AC at right angles to each other and completing the triangle ABC . Then, the side, $AB = x = \sqrt{a}$, since the triangles, ABC and DBA , are similar, and:

$$BC : BA :: BA : BD, \text{ or}$$

$$a : x :: x : 1.$$

$$\therefore x^2 = a \text{ and } x = \sqrt{a}.$$

To find the fourth root, make $BC = \sqrt{a}$, the latter value having been previously obtained as above. Similarly, for the eighth root, make $BC = \sqrt[4]{a}$.

If a is less than unity, construct the triangle, Fig. 10, so that $BC = 1$ and $BD = a$; then, as before:

$$BC : BA :: BA : BD, \text{ or}$$

$$1 : x :: x : a.$$

$$\therefore x = \sqrt{a}.$$

The triangle ABC may be drawn most readily by using BC as a diameter from which to describe a semicircle BAC , and then drawing the perpendicular DA to meet the circumference at A . In any triangle formed thus of two chords and a diameter, the angle A is a right angle, and either chord, as BA , is

a mean proportional between the diameter BC and the segment of the diameter BD , adjacent to that chord.

(*b*) For obtaining the odd-numbered roots, as the cube root, fifth root, etc., there are several methods, all somewhat complex. For example, referring to Fig. 9, we note, as to the lines drawn from the origin O to the vertices of the polygon, that :

$$OA/OB = a/1 \text{ and } O_2/OA = a^2/a = a;$$

i.e., that there is the same ratio, a , between each pair of consecutive lines thus drawn, and hence that these lines represent by their lengths the values of the terms of a geometrical progression, an operation in which each term is equal to the preceding term, multiplied or divided by a constant number called the *ratio*.

Again, while in Fig. 9 the angle, as BOA , formed by lines drawn from the origin to two consecutive vertices of the polygon, is 90° , it is evident that this angle may have varying values in different spiral polygons, providing it is always the same throughout any given polygon. Hence, the angle may be assumed to decrease in an infinite series of polygons until it becomes infinitely small, in which case the spiral polygon would be replaced by a curve called the *Equiangular Spiral*, of which curve any line, as OA , Fig. 9, is a *radius vector*.

Owing to the properties of these radii vectores as terms of a geometrical progression, the equiangular spiral may be used in obtaining odd- or even-numbered roots. Thus, if l be the last term and a the first term of a geometrical progression, n the number of terms, and r the common ratio, then :

$$l = ar^{n-1}, l/a = r^{n-1}, \text{ and } r = \sqrt[n-1]{l/a}.$$

If, then, we wish to find graphically the $n-1$ root of a quantity equal to l/a , the equiangular spiral is constructed, and to it there are drawn a radius vector equal to a and another equal to l , and the angle included between these vectors is divided into

$n-1$ equal parts. The radii vectores bounding these equal angular divisions will be the intermediate terms of the geometrical progression of which a is the first and l the last term. The required root is equal to the ratio r , and that ratio is the quotient of any one of the radii vectores, divided by the one immediately preceding it.

The characteristic property of the equiangular spiral is that the curve cuts all of the radii vectores at a constant angle, *i.e.*, that the angle between the tangent at any point of the curve and the radius vector drawn to that point, is constant. The polar equation of the curve is :

$$r = a^\theta,$$

or,
$$\log r = \theta \log a,$$

in which r is the length of the radius vector, a is an arbitrary constant, and θ is the vectorial angle.

This curve is also called the logarithmic spiral. The modulus of the system of logarithms which has a as its base is $\frac{rd\theta}{dr}$, and this modulus is the tangent of the constant angle be-

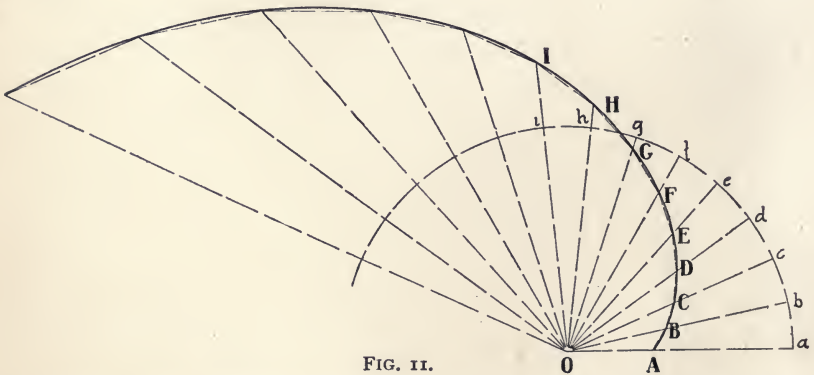

FIG. 11.

tween any radius vector and the tangent to the curve at the point where the radius vector cuts the curve.

One method of constructing the equiangular spiral is shown in Fig. 11. With the pole O as a centre and any convenient

radius, as Oa , describe a circle; on the circumference, lay off the equal arcs ab , bc , cd , etc.; the lines Oa , Ob , Oc , etc., joining these points of division with the pole, are the radii vectores, which are thus spaced at equal angular intervals. From any point, as A , on Oa , draw the line AB , giving the angle OAB any convenient value, preferably 90° or 120° ; from B , draw BC , making angle OBC equal to angle OAB . The $A, B, C \dots I$, thus found, are points on the equiangular spiral, as may readily be seen from the similar triangles OAB , OBC , OCD , etc.; through these points, a fair curve may be drawn and the spiral thus described.

PROBLEMS

It will be understood that, throughout this book, all problems assigned shall be worked by graphic methods.

1. A monument 275 feet high stands upon a plain whose elevation above the sea is 350 feet. Find the height of the top of the monument above sea level.
2. Find the difference in the readings of two Centigrade thermometers in one of which the mercury stood at 72° and in the other at 80° .
3. Represent the area of a triangle whose altitude is 1.5 feet and base 3.5 yards.
4. Indicate the ratio of the specific gravity of glass, taken as 3.3, to that of iron, taken as 7.7.
5. Find $\frac{2}{3}$ of $\frac{4}{5}$ of 10.
6. Represent the ratio of a diagonal to the side of a square 17 inches in length.
7. Find the cubic contents of a tank each dimension of which is 12 feet.
8. Find the sum of 3.4 pounds and 5.2 pounds.
9. Given the lines A — and B —; find their sum.
10. From 8.6 tons subtract 6 tons.
11. From an iron rod 12 feet long, weighing 16 pounds, there is cut a piece 5 pounds in weight. Find the length of the remainder.
12. Multiply 2.5 by 4.2.

13. Find a force which is 8.5 times as great as the force F —.
14. Find the length of one of the seven equal parts of a line 12 inches long.
15. If a line 9 inches long represents an area of 1500 square feet, determine the length of a line which will represent one-fourth of that area.
16. Find the third power of 3, if a scale of half inch equals one unit.
17. Find the fourth power of 4, taking any convenient scale for a unit.
18. With a scale of two inches equal one unit, find the cube root of 2.
19. Find the length of a line corresponding to the $3/2$ power of 2.5, using a scale 2 inches equals one unit.
20. Find the length of a radius vector of the logarithmic spiral, when a equals 2, θ equals $114^{\circ}.6$, using a scale of one inch equals one unit.

CHAPTER II

GRAPHIC MEASUREMENT OF AREAS

THE area of a rectangle is the product of its length by its breadth, that of a triangle the product of the base by one-half the altitude. In either case, it is evident that the operation is one of multiplication simply, which operation can be performed, as in Art. 4, by graphic methods and a line obtained which shall represent the magnitude of the area of the figure; *i.e.*, if one inch is the unit of measurement and the line thus determined is 3.5 inches long, the required area will be 3.5 square inches. The graphic measurement of areas thus obviates computation, and further, as will be shown, the methods used make possible the replacement of an area of curvilinear or other irregular form by an equivalent area bounded by straight lines and having as small a number of sides as is desired.

9. Triangular Areas. If b be the base of a triangle and a its altitude, the area, $x = ab/2$. From Art. 4, it is evident that, in finding the line x which shall represent this area, two similar triangles must be so constructed that their dimensions, a , b , x , and z , shall form the members of a proportion.

(a) Let ABC , Fig. 12, be the triangle whose area is required.

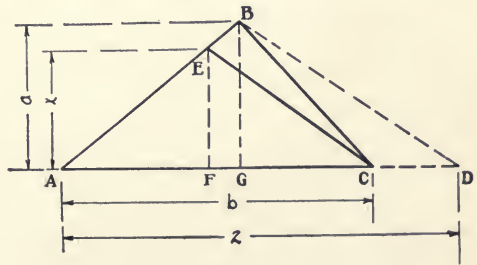

FIG. 12.

On AC prolonged lay off $AD = z$; draw a straight line from D to B ; from C , draw CE parallel to BD ;

from E drop the perpendicular EF on the base AC . Then, the triangles AEC and ABD are similar, and the required area, $x = ab/2 = EF$, since:

$$\begin{aligned} EF:BG &:: AC:AD, \text{ or} \\ x:a &:: b:2. \\ \therefore x &= ab/2. \end{aligned}$$

Since the same result will be obtained from the proportion:

$$x:b::a:2,$$

it is evident that the diagram can be so constructed that the line representing 2 units shall be parallel to the given altitude BG , in which case x will be a segment of the base AC , or of that base prolonged.

(*b*) The line representing two units need not, however, be parallel to, or a segment of, either the base or the altitude of the given triangle. Thus, in Fig. 13, let ABC be the triangle whose area is required.

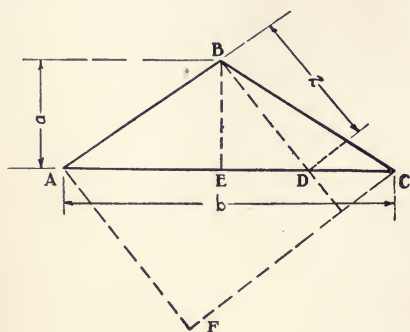

FIG. 13.

From B , lay off $BD = 2$ intersecting AC at D ; from A draw AF parallel to BD , and from C draw CF perpendicular to AF . Then, the triangles BED and CFA are similar and:

$$\begin{aligned} CF:BE &:: AC:BD, \text{ or} \\ x:a &:: b:2. \\ \therefore x &= ab/2. \end{aligned}$$

10. Quadrilateral Areas. The line representing the area of a quadrilateral figure may be obtained in any one of several ways. If the area is that of a parallelogram, the product of the length b by the breadth a may be found by the methods of Art. 4; or any quadrilateral figure may be divided by a diagonal into two triangles, the areas of the latter found separately, and their sum

taken as that of the quadrilateral; or, finally, the quadrilateral may be reduced to its equivalent triangle and the area of the latter ascertained. The first two methods have been already discussed.

(a) Let $ABCD$, Fig. 14, be the quadrilateral whose area is to be found. Draw the diagonal, BD , and the line CE parallel thereto, intersecting AD prolonged at E ; draw BE . Then, the triangles BDC and BDE are equal in area, as they have the same base, BD , and the same altitude in the perpendicular distance between BD and CE . As these triangles are equal, the triangles:

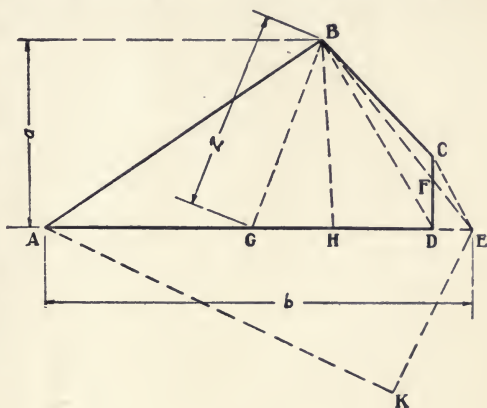

FIG 14.

$$BFD + BFC = BFD + DFE.$$

$$\therefore BFC = DFE.$$

Hence, the triangle ABE is equal in area to the quadrilateral $ABCD$. Drop the perpendicular BH on AE ; with $BG=2$ units, intersect AE at G ; draw EK parallel to BG , and AK perpendicular to EK . Then, the triangles AKE and BHG are similar and:

$$AK : AE :: BH : BG, \text{ or}$$

$$AK : b : a : 2.$$

$$\therefore AK = ab/2 = ABE = \text{area } ABE = \text{area } ABCD.$$

11. Areas of Polygons having More than Four Sides. When the polygon has more than four sides, its area is most readily found by the method just explained, *i.e.*, by reducing the poly-

gon to its equivalent triangle and determining the area of the latter.

(a) Thus, Fig. 15, let $ABCDEF$ be an irregular, six-sided

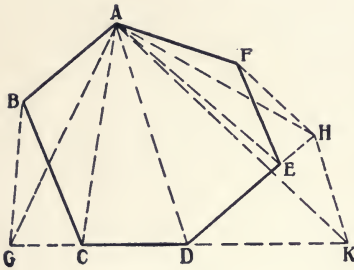

FIG. 15.

polygon whose area is required. From A draw AC , forming the triangle ABC ; from B draw BG parallel to AC and meeting DC prolonged at G ; connect A and G . Then, the triangles ACB and ACG are equal in area, since they have the same base AC and the same altitude. Hence

ACG may be substituted for ABC and the polygon becomes $AGDEF$, which is five-sided.

Similarly, draw the diagonal AE , FH parallel thereto and meeting DE produced at H , and also the line AH . Substituting the equivalent triangle AEH for the triangle AEF , the polygon becomes $AGDH$, which is a quadrilateral.

Finally, draw the diagonal AD and the line HK parallel thereto and meeting GD prolonged at K ; connect A and K . Substituting the triangle ADK for the triangle ADH , the polygon becomes three-sided as the triangle AGK , whose area may be found by the method of Art. 9.

(b) Again, it may be desired, as in rectifying a boundary line, to replace an irregular polygonal area by an equivalent quadrilateral, one of whose sides is a continuation of a specified side of the original polygon. Figure 16 gives a simple method* of effecting this.

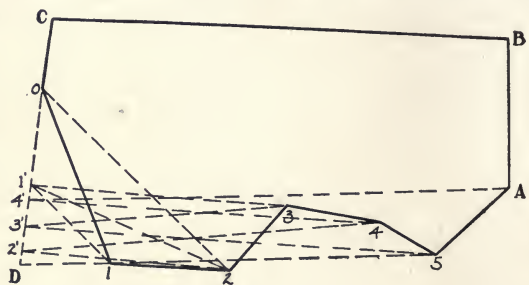

FIG. 16.

Figure 16 gives a simple method* of effecting this.

* Cremona, Graphical Statics, Oxford, 1890, p. 81.

In this figure, the polygon $ABCO_{12345}$ is to be replaced by an equivalent quadrilateral, one of whose sides shall be a continuation of the side CO of the polygon. Draw the diagonal o_2 and the line $i'1$ parallel thereto, intersecting CO prolonged at i' . Then, the triangles o_21 and o_2i' are equal in area; substituting the latter for the former, the polygon becomes $ABCO_{1'2345}$. Similarly, draw lines, intersecting CO prolonged, as follows:

- $22'$ parallel to $31'$; draw $2'3$; polygon becomes $ABC2'345$;
- $33'$ parallel to $42'$; draw $3'4$; polygon becomes $ABC3'45$;
- $44'$ parallel to $53'$; draw $4'5$; polygon becomes $ABC4'5$;
- $5D$ parallel to $A4'$; draw DA ; polygon becomes $ABCD$.

The polygon $ABCO_{12345}$ is therefore reduced to the equivalent quadrilateral $ABCD$, and the portion, $o_{12345}A$, of the periphery which was made up of a number of segments at various angles, is rectified as the line AD , intersecting the specified side CO , produced, at D .

(c) The method—as given above—of drawing the diagram so that all the new vertices of the polygon shall fall on a specified side, is of especial value in finding the algebraic sum of the areas of the segments of a polygon whose periphery is self-cutting, as at X , Fig. 17. The area thus found is the difference between

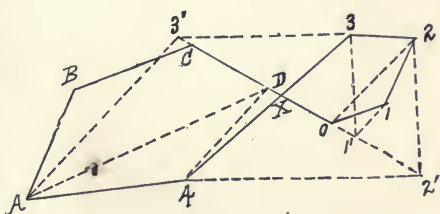

FIG. 17.

those of the larger and smaller segments of the polygon.

In Fig. 17, let CXO be the specified side of the polygon $ABCO_{1234}$ on which the new vertices are to fall. Draw $2o$ and $11'$ parallel thereto and intersecting CXO prolonged at i' ; draw $2i'$. Then, the triangles o_21 and o_2i' are equal in area. Substituting the latter for the former, the polygon becomes

$ABC1'234$. Similarly, draw lines, intersecting CXO prolonged, as follows :

$22'$ parallel to $31'$;

$33'$ parallel to $42'$;

$4D$ parallel to $A3'$;

and the polygon is thus reduced to the quadrilateral $ABCD$, whose area is the difference between the areas of the polygons $ABCX_4$ and X_123 . The area of the quadrilateral may be found by reducing it to its equivalent triangle. This method is of service when the segments of the self-cutting polygonal circuit represent areas whose difference is desired, as, for example, that of the cross-section of an embankment and that of an excavation which is required in connection with it.

12. Areas of Figures whose Peripheries are partially or wholly Curvilinear. When an area is bounded, wholly or in part, by curves, graphic processes for its determination are necessarily approximate. The approximation, however, may be made very close by proper subdivision of the curve.

(a) If the curve be circular, radii drawn from its ends to the centre of the circle will enclose, with the arc, a sector, as $OABCO$, Fig. 18. The area of this figure is equal to one-half the product of the radius by the developed length of the arc, *i.e.*, the area of a circle whose radius is r is πr^2 , that of a 60° sector

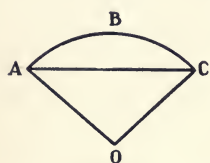

FIG. 18.

$= \pi r^2/6$; the circumference of the circle $= 2\pi r$, one-sixth of that circumference $= \pi r/3$; then $\pi r^2/6 \div \pi r/3 = r/2$. The area of a segment, as $ABCA$, Fig. 18, is evidently equal to that of the sector, less that of the triangle OAC formed by the two radii and the chord of the arc.

If, then, a portion of the periphery of an area be a circular curve, a chord may be drawn to the arc, thus forming a segment, and the latter may be replaced by a triangle whose dimensions

are obtained as above. To make the operation entirely graphic, the development of the arc to form one side of the triangle which is equivalent to the sector, may be performed by stepping off along a tangent a section of the arc sufficiently small to make this subdivision of the arc practically equal in length to its chord, the latter being set off on the tangent as many times as it is contained in the arc.

(b) For curvilinear peripheries in general, Culmann made use of the property of the parabola by which the area of a parabolic segment, as $ABCA$, Fig. 19, is equal to that of a

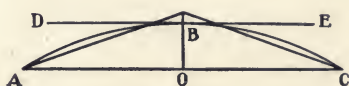

FIG. 19.

triangle whose base is the chord AC and whose altitude is equal to four-thirds of the perpendicular distance OB between the chord and the tangent DE parallel thereto.

If an irregular curvilinear periphery be divided into small sections and each of these sections be regarded as a parabolic arc and its chord drawn, then the segments thus formed may be replaced by their equivalent triangles as above, a chord forming one side of each of these triangles. The polygonal periphery thus constructed may be rectified by the method of Art. 11 (b).

PROBLEMS

21. Find the area of a triangle whose altitude is 4 inches and base 6 inches.
22. The sides of a triangle are 8, 10, and 12. Find its area.
23. Given the area of a triangle, 16; its base, 2.4. Find its altitude.
24. Find the area of a quadrilateral whose sides are respectively 4, 5, 6, and 7: (a) by the method of dividing it into triangles and finding the sum of the areas of those triangles; (b) by the method of reducing to an equivalent triangle and finding the area of that triangle.
25. Find the total area of the faces of a cubical block whose edge is 6.
26. Find the difference in area between an ellipse and an inscribed circle whose centres coincide.

27. Find the area included between two circular arcs.
28. Find the difference in area between a parabolic segment and the inscribed triangle whose vertex coincides with that of the segment.
29. Find the area of a Carnegie angle iron, $6 \times 6 \times \frac{7}{16}$ inches.
30. Find the area between two parallel chords of a circle, one of which subtends an angle of 45° at the centre, and the other an angle of 30° , the radius being 8.

CHAPTER III

FORCES : CONCURRENT ; NON-CONCURRENT, NON-PARALLEL.

13. Definitions. The *magnitude* and *direction* of a force (Art. 1) may be represented by the length and inclination, respectively, of a straight line. Thus, if it be desired to represent a force of 150 pounds acting at an angle of 60° with the horizontal, and if the scale be 100 pounds to the inch, the line OA , Fig. 20, having a length of 1.5 inches and the given angle, is drawn, the arrowhead being added to indicate that the force acts from O to A .

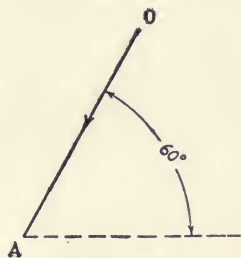

FIG. 20.

Similarly, the *line of action* of the force and its *point of application* to the body may be represented, as in Fig. 21, by a line oa , drawn in the given direction from the point of application, o .

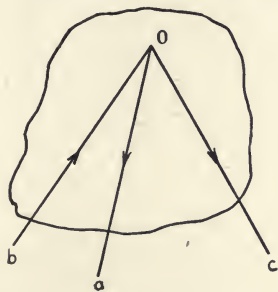

FIG. 21.

Concurrent forces, as oa , ob , oc , Fig. 21, are those whose lines of action intersect in the same point, as o , of a given body. With *non-concurrent forces*, the points of application have different locations and their lines of action, if prolonged, do not meet at one point, as with ab , cd , and ef , Fig. 22.

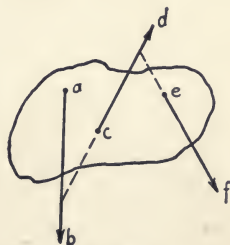

FIG. 22.

Parallel forces are non-concurrent forces

having their lines of action parallel, as ab , cd , ef , Fig. 23. A couple consists of two parallel forces, equal in magnitude but opposite in direction, as ab and cd , Fig. 24. The *arm of a couple* is the perpendicular distance, as ae , between the lines of action of its forces. The effect of a couple, acting on a free, rigid body (Art. 1), is to produce rotation at uniform velocity about an axis

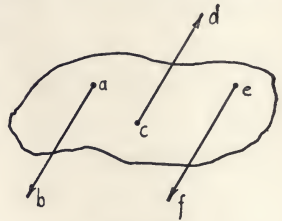

FIG. 23.

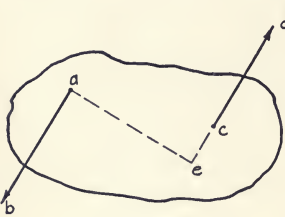

FIG. 24.

passing through the centre of gravity of the body. When a body is at rest or in uniform motion and hence in equilibrium, the application of a couple tends to cause change in its state of rest or motion and therefore to produce non-equilibrium. When,

however, the body, under the action of a couple, is in uniform motion, it is in static equilibrium (Art. 1).

14. Parallelogram of Forces; Composition and Resolution of Forces.

The experimental demonstration of the principles of the *parallelogram of forces* is illustrated by the diagram, Fig. 25. As shown, three cords are tied together as at O ; two of them are led over frictionless supports, as at A and B , respectively; to the ends of the cords are attached the weights W , W_1 , and W_2 , so proportioned

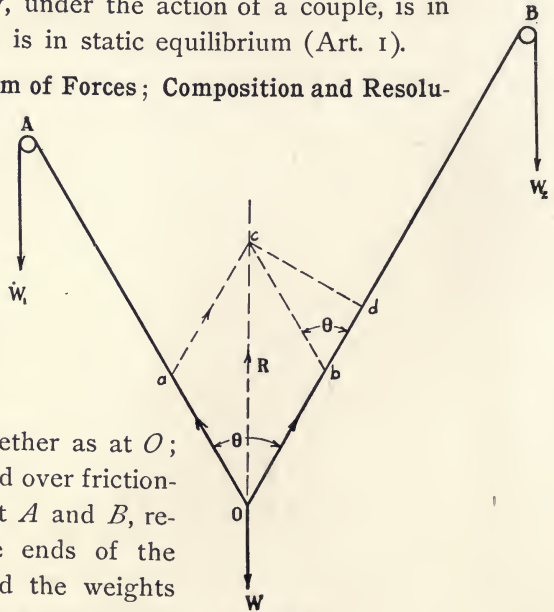

FIG. 25.

that the sum of any two of them is greater than the third. Each of the weights will produce a corresponding tension in its cord, and when, under the action of gravity, the system assumes equilibrium, as shown in the figure, there will be three concurrent forces, W , W_1 , and W_2 , acting from the common point of application O in the lines of action OA , OB , and OW , respectively. There is then laid off, on the scale adopted, $Oa = W_1$ and $Ob = W_2$, and the parallelogram $Oacb$ is completed. The diagonal Oc , which is a prolongation of the line of action OW , will be found to be equal, on the same scale as above, to the weight W .

It is evident that the force W , acting vertically downward, balances the forces W_1 and W_2 , acting on the lines OA and OB , respectively; further, it is clear that the force W would also balance exactly the equal force $Oc = R$, acting vertically upward from O . Hence, the force R is the *resultant* or equivalent of the two forces shown in magnitude and direction by the lines Oa and Ob . It follows, therefore, that the *components* of the force R , when resolved along the lines OA and OB , are Oa and Ob , respectively. The diagram thus illustrates the *composition of forces*, in the combination of the forces Oa and Ob into the single force R ; and the *resolution of forces*, along given lines, in the determination of the components Oa and Ob of the force R , resolved along the lines OA and OB , respectively.

The relation of the resultant to its components may also be found analytically. Thus, Fig. 25, let θ be the angle between the forces Oa and Ob ; from c drop the perpendicular cd on the line OB ; then the angle $cbd = \theta$ and the side $bc = Oa = W_1$. From the right-angled triangle Ocd we have :

$$\begin{aligned} \overline{Oc}^2 &= \overline{Od}^2 + \overline{cd}^2; \\ &= (Ob + bd)^2 + \overline{cd}^2; \\ &= \overline{Ob}^2 + 2Ob \times bd + \overline{bd}^2 + \overline{cd}^2; \\ &= \overline{bc}^2 + \overline{Ob}^2 + 2Ob \times bc \cos \theta; \\ R^2 &= W_1^2 + W_2^2 + 2W_1W_2 \cos \theta. \end{aligned}$$

15. **The Force Triangle.** Inspection of Fig. 25 shows that, assuming the side Ob of the parallelogram to be replaced by its equivalent ac , the force R is the resultant of two forces, Oa and ac , which form with it the triangle Oac , and which have directions opposed to that of R in passing around the sides of the triangle from and to any one of its vertices.

As is shown by Fig. 26, either of the forces Oa and ac may also form the diagonal of a parallelogram of forces whose sides are the equivalents of R and the other of the two forces, and is, hence, the resultant of R and the latter force, providing the directions of the three forces be such that that of the resultant opposes those of the other two in passing around the triangle. Thus, the force Oa is the resultant of the forces, $ea = R$ and $Oe = ac$, if the direction of the latter be reversed. Similarly, the force ac is the resultant of the force $af = R$ and of $fc = Oa$, reversed.



FIG. 26.

In general, then, in any triangle whose sides represent forces, any one of the sides is the resultant of the other two, the directions of the three forces being such that that of the resultant is the reverse of those of the other two forces in passing around the triangle. Further, if the forces are in equilibrium, the resultant will be replaced by an equal and opposite force, and the directions of the three forces, in passing around the triangle, will be the same.

In the *Force Triangle* thus formed, there are, for concurrent forces acting from a given point, but two particulars as to each force to be determined—its magnitude and its direction. If, of the six elements thus required to draw the triangle, any four are known, the remaining two may be determined by various geometrical constructions. With non-concurrent forces, the lines of action must also be found, by methods to be given later.

16. The Force (Vector) Polygon. In the force polygon, the methods employed in the construction of the force triangle are extended to cover systems comprising more than three forces. It is evident that such a polygon may be divided by diagonals into triangles and the diagonal forming the resultant of each triangle be combined with the succeeding force to obtain a new resultant, until the final resultant or its reverse, the force necessary to maintain equilibrium, is determined.

Thus, Fig. 27, let 1, 2, 3, 4, and 5 represent in magnitude and direction concurrent forces acting from the point o ; in Fig. 27a, lay off each side, as ab , parallel and equal to its corresponding force, as $o1$, thus forming the *Force Polygon*, $abcdef$; draw the diagonals ac , ad , and ae .

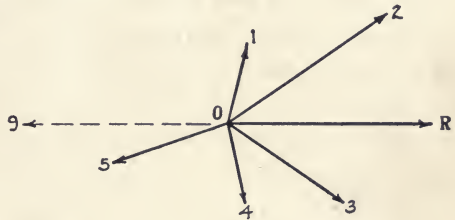

FIG. 27.

Then, the diagonal ac represents a force 6 which is the resultant of forces 1 and 2; similarly, ad , or 7, is the resultant of forces 3 and 6; and finally the force af , or R , is the resultant of forces 5 and 8, and therefore of the entire system, while the equal but reversed force, fa , or 9 , is the force which must be applied at the point o to secure equilibrium.

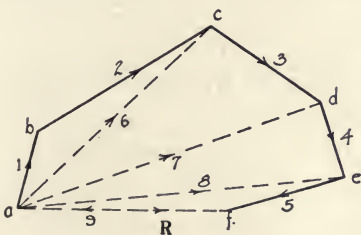

FIG. 27 a.

With regard to the force polygon, it will be observed that :

(a) For equilibrium, the polygon must close; i.e., the final side representing a force must terminate at the starting point, as a , Fig. 27 a, of the polygon. If the polygon does not close, as with $abcde$, there is a resultant force,

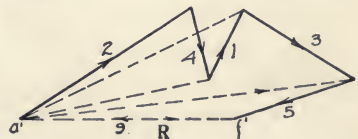

FIG. 27 b.

as af , which will tend to produce non-equilibrium and a motion of translation. Conversely, with concurrent forces, if the force polygon closes, equilibrium exists. With non-concurrent forces, as will be shown, the closure of the polygon does not fulfil all of the conditions for equilibrium.

(b) Since the final side of the polygon represents, in magnitude and direction, the resultant of all the forces of the polygon, if its direction be the reverse of those of these forces in passing around the polygon, it is evident that, by starting at a different vertex, any side may become the final side, and hence *any side of the force polygon represents the resultant of all the other forces forming the polygon*, the direction of this resultant being as stated above.

(c) As with the force triangle, the elements needed to construct the complete polygon are the magnitude and direction of each force. If all but two of these elements are known, the remainder can be determined geometrically and the polygon laid out. Thus, if there are n forces, the total number of elements required will be $2n$, and the number which must be known is $2n - 2$.

17. The Force Polygon is Essentially the Graphic Addition of Forces. As forces are represented by lines, as lines can be added or subtracted by the methods of graphic arithmetic, and as the chief purpose of the force polygon is to obtain the resultant of the forces comprising the system, it follows that the force polygon is, in effect, a method of obtaining the algebraic sum of the forces when projected upon coördinate axes, the sums of these components of the forces giving the similar components of the resultant.

Thus, Fig. 28, let abc be a force triangle and $a'b'$, $b'c'$, and $a''b''$, $b''c''$ be the projections of the forces upon the axes OX and OY , respectively. Then, taking the distances on the axes and proceeding from the origin as positive, and the similar

distances proceeding toward the origin as negative, we have, as the algebraic sum of the components of the forces :

$$a'b' - b'c' = a'c',$$

$$-(a''b'' + b''c'') = -a''c'',$$

the right-hand members of these equations giving the components of the resultant ac .

Hence, it is evident that it is immaterial in what order the forces are taken in drawing the force polygon.

Thus, in Fig. 27 *a*, the order is 1, 2, 3, 4, 5; in Fig. 27 *b*, it is 2, 4, 1, 3, 5; and, in the latter, the resultant, $a'f'$, is the same, in magnitude and direction, as the resultant af in the former figure.

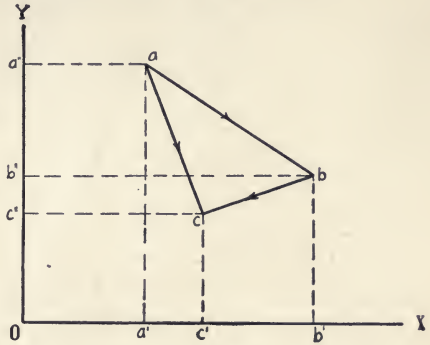

FIG. 28.

18. The Force Polygon as Applied to Non-concurrent Forces. It is an axiom of statics that, when a force acts on a rigid body, the effect of the force will be unchanged at whatever point in its line of action it be applied, if this point be within the body or be rigidly connected with the body. In graphic processes, this principle may be extended, in the determination of lines of action, to points of application which lie beyond the limits of the body.

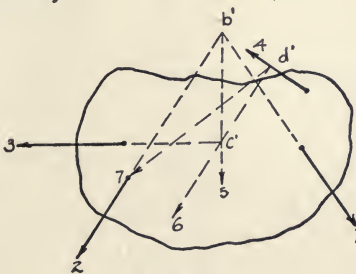

FIG. 29.

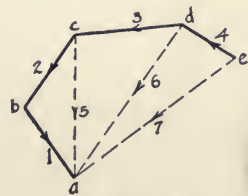

FIG. 29 a.

Thus, Fig. 29, let the forces 1, 2, 3, and 4 act on a rigid body.

Prolonging the lines of action of forces 1 and 2 until they intersect at b' , we have two concurrent forces, $1b'$ and $2b'$, to which the principle of the force triangle may be applied. Therefore, Fig. 29 *a*, draw the triangle abc , and ca or force 5 will be the resultant of the two forces in magnitude and direction, which resultant may be assumed to act at any point in the line $b'5$ drawn from b' and parallel to ca . Proceeding thus, we have next the lines of action of the forces 3 and 5 intersecting at c' , giving the force triangle acd , the resultant da , and the line of action $c'6$. Similarly, the lines of action of the forces 4 and 6 intersect at d' , giving the line of action $d'7$, at any point of which, within the body, the force 7, which is the resultant ea of the four forces, may be assumed to act. From the construction as above, it is evident that the methods of the force polygon, as $abcde$, Fig. 29 *a*, may be applied, in precisely the same way as with concurrent forces, to a system of non-concurrent forces, as 1, 2, 3, 4, Fig. 29, and the resultant ea determined in magnitude and direction.

The force polygon alone is, however, insufficient for the full solution of problems relating to non-concurrent forces, since :

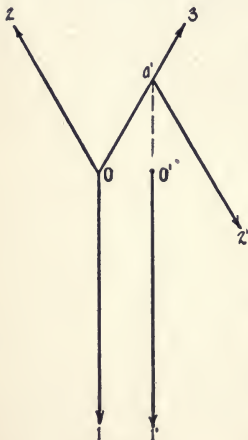

FIG. 30.

(a) It gives only, as in Fig. 29 *a*, the magnitude and direction of the resultant ea , but not its line of action $d'7$, Fig. 29, which must be found either as in the latter figure or by the use of the equilibrium polygon, to be described shortly. The methods of Fig. 29 are cumbrous, and, further, if the lines of action of the forces approach parallelism, their points of intersection, as b' , c' , d' , will lie beyond the limits of the drawing.

(b) Again, with concurrent forces, if the force polygon closes, equilibrium exists; with non-concurrent forces, this is not always the case. Thus, Fig. 30,

let 1, 2, 3, be three concurrent forces in equilibrium ; draw the force triangle, abc , Fig. 30 *a*, which closes, since equilibrium exists. Now, remove the force 1 to a new line of action, $O'I$, to the right of, but parallel to, O_1 , the system thus becoming non-concurrent so far as the force $O'I$ is concerned. The force triangle still closes, but equilibrium does not exist, since the forces $O'I$ and 3 have a resultant $a'z'$, equal in magnitude and opposite in direction to the force 2 and having a different point of application ; *i.e.*, this resultant forms a couple with the force 2, which couple tends to produce a motion of rotation and, hence, non-equilibrium. In general, as in this case, *when the force polygon closes but equilibrium does not exist, there is a resultant couple.*



FIG. 30 *a*.

19. Jointed Frame in Equilibrium under the Action of External Forces. Let Fig: 31 represent a polygonal frame composed of

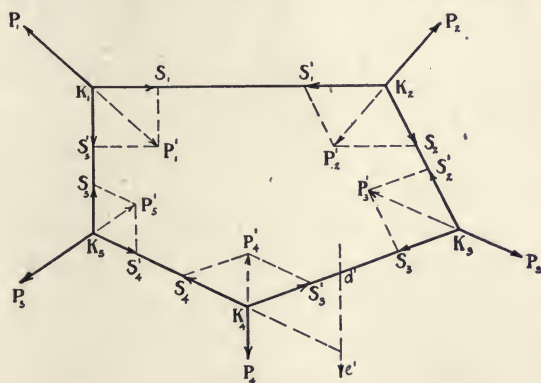

FIG. 31.

straight bars united to each other by joints $K_1 \dots K_5$, the bars being sufficiently rigid to withstand the tensile or compressive stresses resulting from the external forces $P_1 \dots P_5$, applied at the joints.

Assume the frame to be in equilibrium under the action of this system of external forces. Then, at each joint, as K_1 , the external force P_1 must be in equilibrium with the internal forces or stresses S_1 and S'_5 , produced in the bars K_1K_2 and K_1K_5 , respectively, the resultant of these stresses being a force,

P'_1 , equal and opposed to P_1 and assumed to act at the joint K_1 . Similarly, the force P_2 will be held in equilibrium by the forces S'_1 and S_2 , S'_1 being—for equilibrium along the line K_1K_2 —equal and opposed to S_1 . The conditions are similar at the remaining joints, K_3 , K_4 , and K_5 .

Each system of three forces in equilibrium, as P_1 , S_1 , and S'_1 , combines to form a force triangle, as oab , Fig. 31 *a*. The

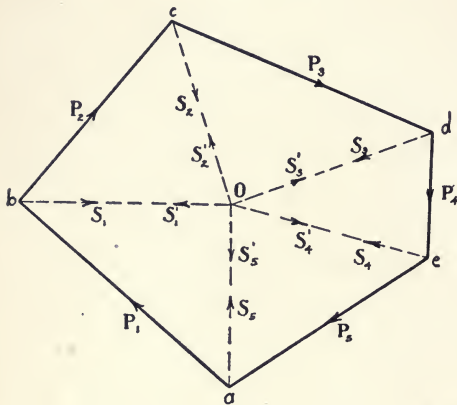

FIG. 31 *a*.

next system forms the triangle obc , the side ob being common to the two triangles, since the internal forces S' and S'_1 are equal in magnitude and have the same line of action K_1K_2 parallel to ob . This condition as to a common side holds for each pair of consecutive triangles. Hence, the five

triangles can be combined to form the closed force polygon, $abcde$, and the lines, $oa \cdots oe$, representing the stresses in the bars, will intersect at one point o .

The character of the stresses is shown by their direction with regard to the joint at which they act. Thus, at K_1 , the direction of P_1 is from a to b , Fig. 31 *a*, and hence that of S_1 is from b to o , or away from K_1 . Therefore, the stress is tensile. Had S_1 acted toward K_1 , the stress in the bar would have been compressive. The tensile stress existing in the bar K_1K_2 forms, with regard to the joints K_1 and K_2 , the internal forces S_1 and S'_1 , respectively.

20. The Equilibrium (Funicular or Cord) Polygon. The polygon $K_1 \cdots K_5$, Fig. 31, is called the *Equilibrium* or *Funicular*

(*Cord*) *Polygon*, although the latter term is only strictly applicable when the stresses in the sides of the polygon are tensile throughout. If, as in Fig. 31, a system of external forces $P_1 \cdots P_5$ act on a rigid body, the equilibrium polygon may be assumed to be substituted for the body, since (Art. 18) a force may be considered as applied at any point in its line of action.

Under these conditions, the equilibrium polygon is assumed to consist of a system of rigid rectilinear bars or sides, $K_1K_2 \cdots K_5K_1$, the adjacent ends of each pair of consecutive sides intersecting at any point in the line of action of one of the external forces. The vertices $K_1 \cdots K_5$, thus formed at these intersections, are called *Joints* or *Nodes*. The sides of the polygon are parallel, respectively, to the *Rays*, as $oa \cdots oe$, Fig. 31 *a*, drawn from the *Pole o*.

Each joint is thus the point of application of three concurrent forces in equilibrium—one an external force, the other two the internal forces or stresses produced by the external force in the two sides intersecting at this joint. Since each end of each side intersects the line of action of an external force, each side, as K_1K_2 , forms the line of action of two internal forces, as S_1 and S'_1 , equal in magnitude but opposite in direction, acting, respectively, from the joints K_1 and K_2 ; the magnitude of each of these stresses is given by the length of the corresponding ray, as ob , Fig. 31 *a*.

It should be borne in mind that the equilibrium polygon does not form, for the internal forces, a force polygon, as described in Art. 16; since its sides represent simply the lines of action of these forces, they do not give the magnitude of the latter, and each side is the line of action of two equal and opposite forces.

With regard to the equilibrium polygon, it will be observed that:

(*a*) For any system of coplanar forces, the number of equilibrium polygons which can be drawn is infinite, since the essential

requirements are only that the sides of the polygon shall be parallel to their corresponding rays and that consecutive sides shall intersect on the line of action of an external force. Hence, with a fixed location of the pole as in Fig. 31 *a*, the polygon may be begun at any point of one of such lines of action, and other polygons starting at different points of the same line will be, in general form, very different from the first polygon, although the corresponding sides of all will be parallel.

Again, the polygon will fulfil the essential requirements as above, whether the pole *o* be located at any point within or without the force polygon, Fig. 31 *a*. Therefore, the location of the pole may be selected at pleasure and the rays drawn; and, for each of such locations, any number of equilibrium polygons may be constructed.

(*b*) *For the equilibrium of a system of complanar, non-concurrent forces, both the force and equilibrium polygons must close.* It has been shown (Art. 18) that the methods of the force polygon may be applied to a system of non-concurrent forces; hence (Art. 16 *a*), for equilibrium, the force polygon must close. This requirement exists also for the equilibrium polygon, as may be seen by considering a system of external forces in non-equilibrium. Thus, in Fig. 31, let the external force P_4 be removed to the right to a parallel line of action $d'e'$, which removal will destroy the equilibrium of the system and, as shown in Art. 18 *b*, will produce a resultant couple, although the force polygon $abcde$ will still close. The equilibrium polygon, however, will not close, since the sides K_3d' and K_3e' , when drawn as before parallel to the rays od and oe , respectively, will intersect the new line of action at different points d' and e' ; hence, as the polygon does not close, the equal and opposite internal forces S_3 and S'_3 , which for equilibrium should neutralize each other, will have different lines of action, and non-equilibrium will exist.

That the closure of the polygon is essential for equilibrium

is clear also from a consideration of the conditions governing its construction. Each of the external forces, as P_1 , is maintained in equilibrium by the resultant internal forces, as S_1 and S'_5 ; each side of the polygon is in equilibrium because it is the line of action of two equal and opposite internal forces, as S_1 and S'_1 . Assuming the first four sides of the polygon to be thus held in equilibrium, there remain the internal forces S_5 and S'_5 , which, as given by the ray oa , are equal in magnitude and opposite in direction. Hence, in order that these forces shall neutralize each other and equilibrium shall exist in the system, they must have the same line of action K_5K_1 , and the polygon must close.

(c) With regard to the number of known elements necessary for the construction of the equilibrium polygon, it is evident, since the sides of the polygon are parallel to the rays and since the rays intersect at the pole, that if the external forces are known and in equilibrium, and if the directions of two consecutive sides of the polygon be assumed, the directions of the remaining sides and the magnitudes of the stresses which they represent can be found.

Again, if the lines of action of external forces in equilibrium and the magnitude of one force are given, and if the form of the equilibrium polygon be assumed, the magnitudes of the remaining external forces can be determined.

21. Resultant of Complanar, Non-concurrent Forces. The properties of the equilibrium polygon make it possible to determine fully the resultant of a number of consecutive forces forming part of a system of complanar, non-concurrent forces in equilibrium. Thus, let $P_1 \dots P_6$, Fig. 32, be the lines of action of the system. Construct the force polygon, Fig. 32 *a*, locate the pole o , draw the rays, lay out the equilibrium polygon $K_1 \dots K_6$, and determine the character of the stresses in its sides.

Now, assume the polygon to be cut into two sections, one to the left, the other to the right, of the line FG , which intersects

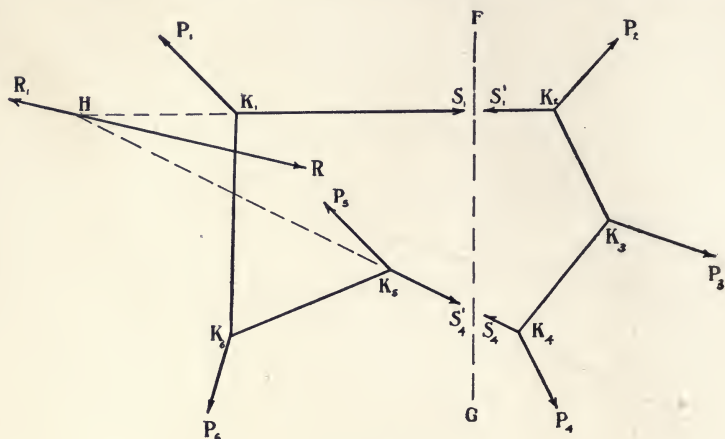

FIG. 32.

the sides K_1K_2 and K_4K_5 . It is evident that, if there were no stresses in these sides, forces equal in magnitude and the same in directions and lines of action as the internal forces S_1 and S'_4 would be required to maintain in equilibrium the left-hand

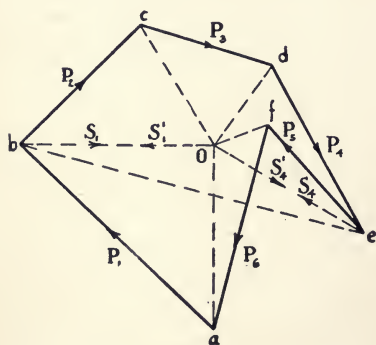

FIG. 32 a.

section of the polygon, and that a similar requirement holds as to the right-hand section and the internal forces S'_1 and S_4 . Hence, the internal forces S_1 and S'_4 hold in equilibrium the external forces, P_1 , P_5 , and P_6 , in the left-hand section, and similarly the internal forces S'_1 and S_4 hold the forces P_2 and P_3 and P_4 in equilibrium. This is evident, further, from the

force polygon, since the diagonal be represents the resultant of the forces S_1 and S'_4 , and is equal in magnitude and opposite in

direction to the diagonal eb which is the resultant of the forces P_5 , P_6 , and P_1 . Similarly, eb represents the resultant of S'_1 and S_4 and is equal in magnitude and opposite in direction to be , the resultant of P_2 , P_3 , and P_4 .

Since the intersection of the lines of action of two forces is a point in the line of action of their resultant, the line of action of the resultant of the internal forces S_1 and S'_4 can be determined by prolonging the sides S_1K_1 and S'_4K_5 , until they meet at the point H . Through H , and parallel to be , draw HR , the line of action of the force R , the resultant of S_1 and S'_4 , whose magnitude is given by the length of the line be ; the resultant of the external forces P_1 , P_5 , and P_6 is R_1 , identical with R except that it is opposite in direction. Since the system $P_1 \dots P_6$ is in equilibrium, the resultant of the forces P_2 , P_3 , and P_4 is equal in magnitude but opposite in direction to R_1 , and has the same line of action.

The internal forces S_1 and S'_1 constitute a single tensile stress (Art. 19) in the side K_1K_2 , which stress is equivalent to two equal and opposite forces having the same line of action, when considered with regard to its effect upon the joints K_1 and K_2 ; similarly, the internal forces S_4 and S'_4 represent a tensile stress in the side K_4K_5 . It will be seen, then, that at any section, as FG , the external forces are held in equilibrium by the stresses at that section — a principle which is of fundamental importance in the analysis of the stresses in beams.

22. Equilibrium of Coplanar Forces. The principles established in the foregoing articles for the equilibrium of a system of coplanar forces are :

(a) *For concurrent forces*, the force polygon must close. Conversely, if the force polygon closes, the system is in equilibrium.

(b) *For non-concurrent forces*, both the force and equilibrium polygons must close. Conversely, if the force polygon and any equilibrium polygon close, the system is in equilibrium.

PROBLEMS

31. A rope 14 feet long supports a weight of 100 pounds fastened at a point 8 feet from one extremity. If the supports are 10 feet apart and at the same level, what is the tension in each portion of the rope?

32. Two forces of 8 and 10 units act at an angle of 30° with each other. Find the magnitude and direction of their resultant.

33. Three forces, 15, 20, and 25 pounds, act on a particle at angles 30° , 60° , and 120° , respectively, with the axis of abscissas. Find a simpler equivalent set of two forces, acting at 0° and 135° with the same axis.

34. A flag weighing 3 pounds is blown horizontally by the wind with a force of 4 pounds. What is the tension in the halliards?

35. Forces of 9, 12, 15, 18, 21, and 24 pounds act along the radii of a regular hexagon from the centre. Find the magnitude and direction of their resultant.

36. Find the forces acting on the rafters and tie rod of a simple triangular roof truss of 24 feet span and 4 feet depth, if it supports a load of 5 tons at the apex.

37. A rectangular box containing a ball weighing 160 pounds is tilted about one of its lower edges through an angle of 40° . Find the pressure between the ball and the box.

38. What is the resistance which a stone 4 inches high offers to a wheel 4 feet in diameter passing over it if the wheel with its load weighs 4 tons?

39. What is the pressure on the crosshead guides of an engine, if the piston pressure is 25,000 pounds and the maximum angle made by the connecting rod with the line of action of the piston is 15° ?

40. A ladder 30 feet long weighing 120 pounds leans against a smooth vertical wall, and makes an angle of 60° with the ground. A man of 180 pounds weight stands on a rung halfway up the ladder. What is the horizontal thrust on the ground?

41. A weight of 600 pounds is supported by a rope 12 feet long. What force, acting horizontally, is necessary to carry the weight 4 feet out of its perpendicular?

42. The length of the string of a conical pendulum, whose mass is 2 pounds, is 3 feet and the angle of inclination to the vertical is 45° . What is the tension?

43. A pair of shear legs is 45 feet high when upright, each leg being 60 feet long. The back leg is 90 feet. The plane of the legs makes an angle of 30° with the vertical. What is the stress in the legs when a weight of 50 tons is supported?

44. The jib of a derrick is inclined at 30° to the vertical, and the topping lift is attached to a point vertically over the foot of the jib at a height equal to its length. Find the tension in the lift and the thrust in the jib when lifting 6 tons.

45. Let the forces 1, 2, 3, 4, 5 act on a rigid body along the sides of a regular pentagon, taken in order. Find the magnitude and direction of their resultant.

46. Take the jointed frame, Fig. 31, assuming P_1 and P_2 known in direction and magnitude. Determine the magnitude and direction of P_3 , P_4 , P_5 , that the frame may be in equilibrium.

CHAPTER IV

PARALLEL FORCES; COUPLES; CENTRE OF GRAVITY

23. Force Polygon for Parallel Forces. The force polygon for a system of parallel forces is a straight line. Thus, Fig. 33,

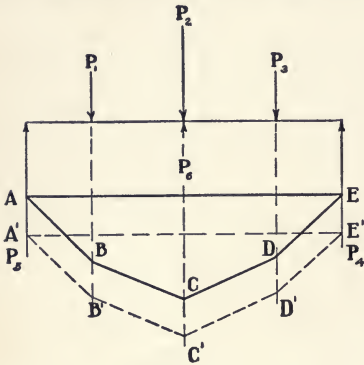

FIG. 33.

let $P_1 \dots P_5$ represent the lines of action of a system of coplanar parallel forces in equilibrium, the magnitude of the forces being known. In Fig. 33 *a* lay off the three consecutive downward forces P_1, P_2, P_3 , on the straight line ad , making ab = the magnitude of P_1 , bc that of P_2 , and cd that of P_3 .

Draw the equilibrium polygon

$ABCDE$ and the ray Oe parallel to the closing side AE . Then $de = P_4$ and $ea = P_5$.

Since the system is in equilibrium, the sum of the magnitudes of the downward forces must be equal to the similar sum of the upward forces. Hence, $ad = da$; the forces, as set off, start from, and return to, the same point a ; and the line $ad - da$ represents a closed force polygon for the system, the points a, b, c, d, e

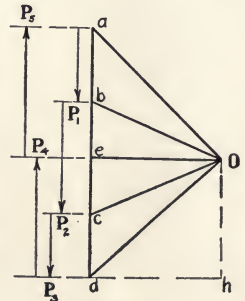

FIG. 33 *a*.

corresponding with the vertices of the force polygon for non-parallel forces.

If, as in Fig. 33 *b*, the force P_2 be replaced by a force P_6 acting upward, then $a'b' = P_1$, $b'f = P_6$, $fd' = P_3$, $d'g = P_4$, $ga' = P_5$, and the equilibrium

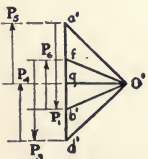

FIG. 33 *b*.

polygon is $A'B'C'D'E'$. In either case, the location of the pole O may be selected at pleasure and the rays Oa, Ob , etc., drawn as described previously for non-parallel forces. Preferably, the pole should be located, as in Fig. 33 *a*, opposite the middle point of the force line ad and at a pole-distance $dh = ad/2$, the rays Oa and Od being thus at right angles to each other. For clearness, the forces are shown, in magnitude and direction, at the right of Figs. 33 *a* and 33 *b*, although this construction forms no part of the polygons.

24. Equilibrium of Parallel Forces. Consider :

(*a*) *Three forces in equilibrium*, as $P_1 \dots P_3$ in Fig. 34, the lines of action and directions of all of the forces and the magnitude of one, as P_1 , being known. It is required to determine the magnitudes of P_2 and P_3 . Evidently :

$$P_1 = P_2 + P_3,$$

and, taking moments (Art. 35) about the point C :

$$P_2 \times BC = P_1 \times AC.$$

$$\therefore P_2 = P_1 \times AC/BC.$$

Such a problem may be solved graphically in various ways :

by graphic arithmetic, by the resolution of forces, or by the force and equilibrium polygons.

Thus, in the first case, inspection of the last equation shows that it is necessary only (Art. 6 *a*) to construct two similar triangles of such form that their sides P_2, P_1, AC , and BC shall give the proportion :

$$P_2 : P_1 :: AC : BC.$$

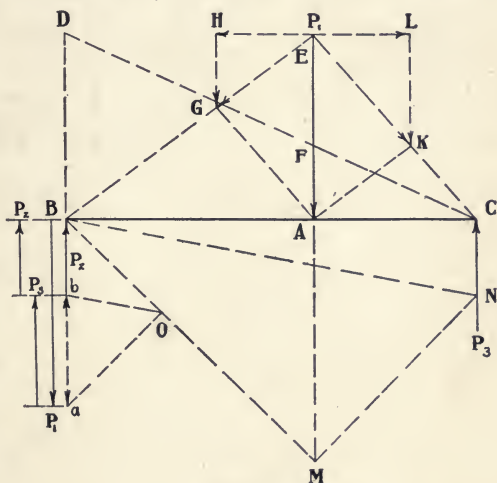

FIG. 34.

Hence, from B , the point of application of P_2 , draw BD parallel and equal to P_1 , and from D draw the line CD joining the latter point with the point of application of P_3 . Then, the triangles ACF and BCD are similar and:

$$AF:BD :: AC:BC, \text{ or}$$

$$AF = P_1 \times AC/BC = P_2, \text{ and}$$

$$P_3 = P_1 - P_2 = AE - AF = EF.$$

For the second solution, join E with B and C and resolve (Art. 14) the force P_1 on the lines ED and EC , giving thus the forces EG and EK , respectively. Resolve each of the forces into components parallel to the line BC and to the lines of action of the forces P_2 and P_3 . If we consider the forces EG and EK as applied at the points B and C , respectively, their horizontal components, EH and EL , will neutralize each other and the vertical components, HG and LK , will be equal in magnitude but opposite in direction to P_2 and P_3 , respectively.

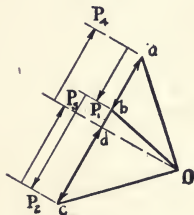
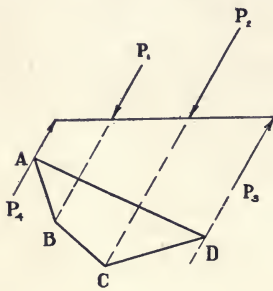

FIG. 35.

To solve by the force and equilibrium polygons, lay off $Ba = P_1$, locate the pole O , and draw the rays OB and Oa . From any point, as B , on the line of action of P_2 draw the side BM of the equilibrium polygon meeting the line of action of P_1 at M ; from M draw MN parallel to Oa and cutting the line of action of P_3 at N ; from N draw NB , completing the polygon. Then, draw the ray Ob parallel to NB , and $bB = P_2$ and $ab = P_3$.

In this example, the forces have been assumed, for convenience, as vertical. They may be inclined at any angle, the only requirement being that they shall be parallel. By similar methods for a similar system, the magnitude of the force P_1 can be determined

when the magnitudes of P_2 and P_3 and the lines of action of the three forces are known.

(b) *Four forces in equilibrium and unequal in magnitude.* As a further example, consider the system shown in Fig. 35, in which the lines of action and directions of the forces $P_1 \cdots P_4$ and the magnitudes of the forces P_1 and P_2 are known.

On the line ac parallel to the lines of action of the forces, lay off the force polygon, making $ab = P_1$ and $bc = P_2$; locate the pole and draw Oa , Ob , and Oc . From any point, as A , on the line of action of P_4 , draw the side AB of the equilibrium polygon parallel to the ray Oa ; make BC parallel to Ob and CD parallel to Oc , and draw the closing side AD . Then, draw the ray Od parallel to the side AD , and $cd = P_3$ and $da = P_4$, since, as the system is in equilibrium, $ac = P_1 + P_2 = ca = P_3 + P_4$, is a closed polygon.

25. Composition and Resolution of Parallel Forces. The composition and resolution of coplanar parallel forces may be effected by methods similar to those already described. In the *composition* of a system of forces, the object is either the determination of an equivalent system having a smaller number of forces than the given system or of a single force which is the *resultant* of the latter system. In the *resolution* of forces, a system of two or more forces is found which is the equivalent of the single force given, the latter being thus the resultant of the system to be determined.

(a) *Composition of parallel forces.* In Fig. 36, let $P_1 \cdots P_4$ be a system of coplanar parallel forces whose magnitudes, directions, and lines of action are known, and let it be required to replace this system by two forces, P_5 and P_6 , which are to be parallel to those of the given system, whose lines of action shall pass through the points G and H , respectively, and whose magnitudes are to be determined.

Construct the force polygon $ab = P_1 \cdots de = P_4$; draw the

rays $Oa \dots Oe$; lay out the equilibrium

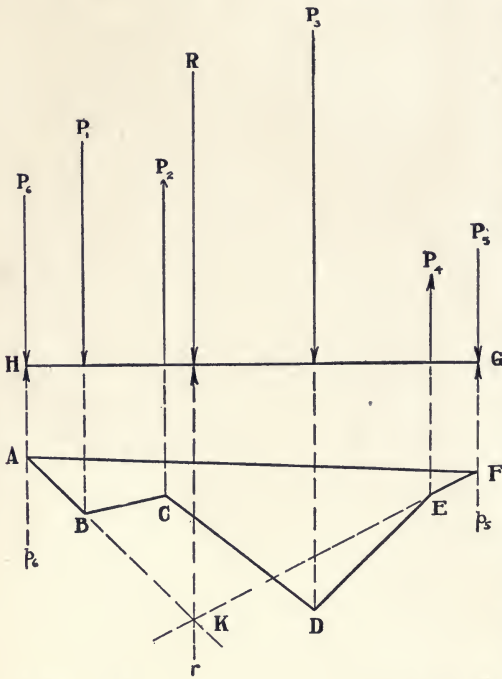

polygon, making AB parallel to Oa , BC to Ob , etc.; draw the ray Of parallel to the side FA . If the six forces formed a system in equilibrium, they would be represented by the closed equilibrium polygon $ABCDEF$ and by a closed force polygon, $ad-da$, the distance from e to f and from f to a being equal to the upward forces, p_5 and p_6 . Since the two latter forces would thus hold the system $P_1 \dots P_4$ in equilibrium,

it is evident that the forces P_5 and P_6 , equal in magnitude but opposite in direction to p_5 and p_6 , are equivalent to the system $P_1 \dots P_4$.

The magnitude of the resultant R of the system $P_1 \dots P_4$ is given by the distance ea in the force polygon, *i.e.*, the magnitude of the force r which is necessary to hold the four forces in equilibrium. Considering the equilibrium and force polygons as now limited to

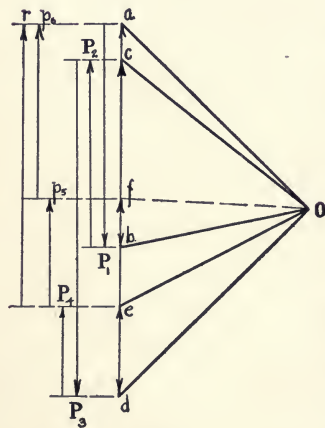

FIG. 36.

the forces $P_1 \dots P_4$ and r , the former polygon is begun at any

point B on the line of action of P_1 and is drawn as before to the point E ; then, from B and E , the sides BK and EK are drawn intersecting at K and parallel respectively to the rays Oa and Oe ; the complete polygon is now $BCDEK$. The intersection K is a point on the line of action of the force r and therefore of the resultant R , the latter being equal in magnitude but opposite in direction to the force.

(b) *Resolution of parallel forces.* The decomposition of a force into two or more parallel components is the reverse of the operation just described. Thus, Figs. 37 and 37a, let ABC and Oab represent respectively the equilibrium, and force polygons of a system of forces $P_1, P_2,$ and P_3 , in equilibrium and let it be required to replace the force P_1 by the equivalent system P_4 and P_5 , whose lines of action pass through the points D and E , respectively, one on each side of the force P_1 . In Fig. 37, prolong the lines of action of P_4 and P_5 until they intersect the equilibrium polygon at F and G , respectively; connect F and G , the complete polygon becoming $AFGCA$. In Fig. 37b, draw the ray Od parallel to the side FG . Then, $ad = P_4$, $db = P_5$, and $ad + db = P_4 + P_5 = P_1$.

If both of the required components are on the same side of the force P_1 , the method is similar. Thus, Fig. 37, let it be required to resolve P_1 into the two parallel forces P_6 and P_7 , whose lines of action pass through the points K and L , respectively. Prolong the line of action of P_6 until it intersects the side AB of the equilibrium

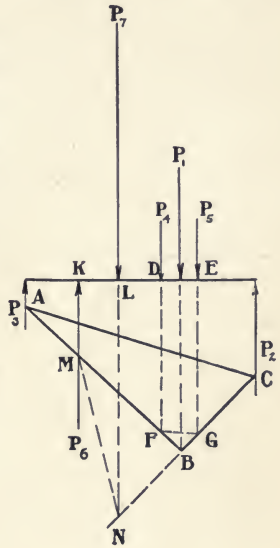

FIG. 37.

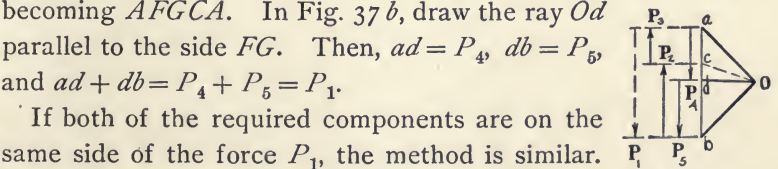

FIG. 37a.

FIG. 37b. This diagram shows the force polygon Oab and equilibrium polygon abc . A horizontal line contains points a, c, b . Vertical lines represent forces P_3, P_2, P_1, P_4, P_5 . A ray Od is drawn from O to d on ab , parallel to the side FG of the complete polygon in Fig. 37. The segments ad and db represent the magnitudes of the component forces P_4 and P_5 .

polygon at the point M ; similarly, let the line of action of P_7 meet the side CB produced at the point N ; connect M and N , the complete polygon becoming $AMNC$. In Fig. 37c, draw the ray Oe parallel to the side MN . Then, $ae = P_6$, $eb = P_7$, and $eb - ae = P_7 - P_6 = P_1$, the direction of the force P_6 being upward and that of P_7 downward.

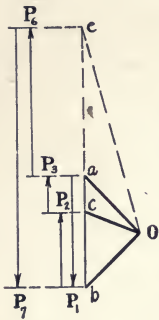

FIG. 37c.

26. Parallel Forces Equal in Magnitude and with Lines of Action at Equal Distances Apart. In Fig. 38, let the forces $1 \dots 7$ be parallel, equal in magnitude, with lines of action at equal distances

apart, and be held in equilibrium by the two equal forces, 9 and 10 , whose lines of action are parallel to those of forces $1 \dots 7$, the distance between forces 7 and 9 or 1 and 10 being one-half that between forces 1 and 2 , or 2 and 3 , etc.

Draw the force polygon $Oa7$ and the equilibrium polygon $ABCDEFGHJK$. Then, in the former polygon, the force $9 = 7, 8$, force $10 = 8, a$, and the resultant, $R = a, 7$; the lines AL and KL , drawn parallel to the rays Oa and $O7$, respectively, intersect at L , a point in the line of action of the resultant.

Draw the line bEh parallel to the closing

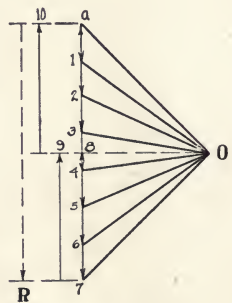
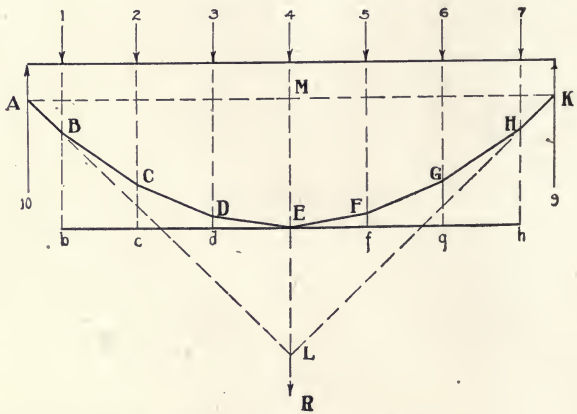

FIG. 38.

side AMK . The lines of action of the forces meet bEh at the points $b, c, d \dots h$. It will be found that :

$$Cc : Dd :: \overline{Ec}^2 : \overline{Ed}^2;$$

i.e., that the points C, D , and E lie on a parabola, since it is a property of that curve that its abscissæ are as the squares of their ordinates. This relation exists also for all other points in the line $A \dots E \dots K$. If therefore, as in the case of a beam uniformly loaded, the system $1 \dots 7$ be replaced by an infinite number of equal and parallel forces infinitely close together, the broken line $A \dots E \dots K$ will become a parabola, whose vertex lies at E , the middle and lowest point of the curve. Since the vertex of a parabola bisects all subtangents, $EM = LM/2$. If the pole O of the force polygon be moved vertically so that the closing line or chord AK is inclined to the horizontal, the corresponding curve $A \dots E \dots K$ will still be a parabola, but its vertex will lie to the right or left, as the case may be, of the line of action of the resultant, which line will still be ML .

27. Couples. A *couple* (Art. 13) consists of two parallel forces which are equal in magnitude and opposite in direction. The *arm of a couple* is the perpendicular distance between the lines of action of the forces. The *moment of a couple* is the product of one of the equal forces by the arm. The *tendency of a couple* is to produce rotation. *Two like couples* — *i.e.*, tending to cause rotation in the same direction — of equal moment in the same plane produce equal effects. *Two unlike complanar couples* of equal moment balance each other and equilibrium exists. The *moment* (Art. 35) *of a force* with respect to a point is the product of the force by the perpendicular distance from its line of action to the point. Consider :

(a) *Two complanar couples in equilibrium.* In Fig. 39, the couple P_1P_2 is given in magnitude, direction, and lines of

action, and it is required to find a coplanar couple which will produce equilibrium. As there are an infinite number of unlike couples which will satisfy the conditions of equilibrium, *i.e.*, having a moment equal to that of the given couple, assume the force P_3 in magnitude, direction, and line of action. From these conditions, there must be determined the line of action of a force, P_4 , equal in magnitude and opposite in direction to P_3 ,

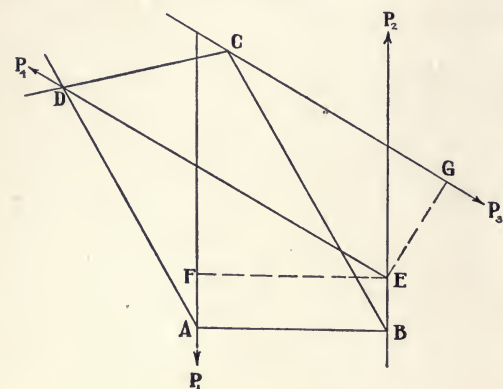

the arm of the couple P_3P_4 being such that its moment shall be equal to that of the couple P_1P_2 . To secure equilibrium, both the force and equilibrium polygons must close.

Lay out the force polygon, making

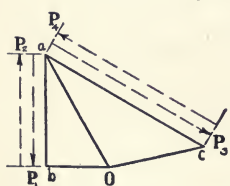

FIG. 39.

$ab = P_1$, $ba = P_2$, $ac = P_3$, and $ca = P_4$; draw the rays Oa , Ob , and Oc , selecting any location for the pole O . Begin the equilibrium polygon at any point, as A , on the line of action of P_1 , making the side AB parallel to Ob , BC to Oa , CD to Oc ,

and AD to Oa . The sides AD and CD intersect in a point D on the line of action of the force P_4 , as that force is, in the force polygon, held in equilibrium by the forces Oc and Oa . Since thus both the force and equilibrium polygons close and the couples are unlike, equilibrium exists and hence:

$$\text{Force } P_1 \times \text{arm } EF = \text{force } P_3 \times \text{arm } EG,$$

as can be shown analytically or by graphic arithmetic.

(b) *Three coplanar couples in equilibrium.* In this case, Fig. 40, there are given, in magnitude, direction, and lines of

action, two like couples P_1P_3 and P_2P_4 , and one opposing couple P_5P_6 , the magnitude of whose forces, to secure equilibrium, is to be determined.

Construct the force polygon $abcd$; although this polygon closes, it is incomplete, as it lacks the forces P_5 and P_6 , which are required for equilibrium. Draw the rays $Oa \dots Od$; starting at any point, as A ,

on the line of action of P_1 , lay out the equilibrium polygon, making the side AB parallel to Ob , BC to Oc , CD to Od , and DE to Oa ; draw AF parallel to Oa , since Oa aids in maintain-

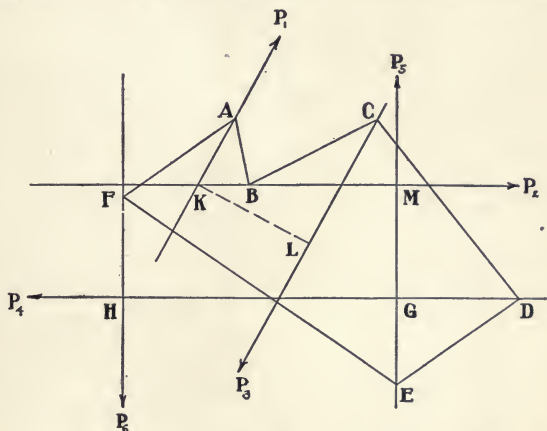

ing the equilibrium of P_1 at the joint A . Connect the intersections E and F , on the lines of action of P_5 and P_6 , by the closing side FE . Finally, draw the ray Oe parallel to the side EF and intersecting at e the line ae drawn parallel to the lines of action of P_5 and P_6 .

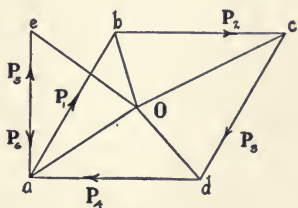

FIG. 40.

Then, ae represents the magnitude of those forces, and the complete polygon is $abcdae$. As both the force and equilibrium polygons close, equilibrium exists. Hence:

$$\text{Force } P_5 \times \text{arm } GH = \text{force } P_1 \times \text{arm } KL + \text{force } P_2 \times \text{arm } GM,$$

since, for equilibrium, the moment of the opposing couple must be equal to the sum of the moments of the two like couples.

28. Centroid; Centre of Gravity. The centre of gravity is virtually the *centroid* or *centre of a system of parallel forces*.

Consider:

(a) *Centroid of two parallel forces.* In Fig. 41, let P_1 and P_2 be two parallel forces acting from the points of application A and B , respectively. Draw the force polygon Oac and the equilibrium polygon ADE ; the resultant $R = P_1 + P_2$ acts on the line GD , the point G dividing the line AB into segments, AG and BG , which are inversely as the forces applied at A and B respectively.

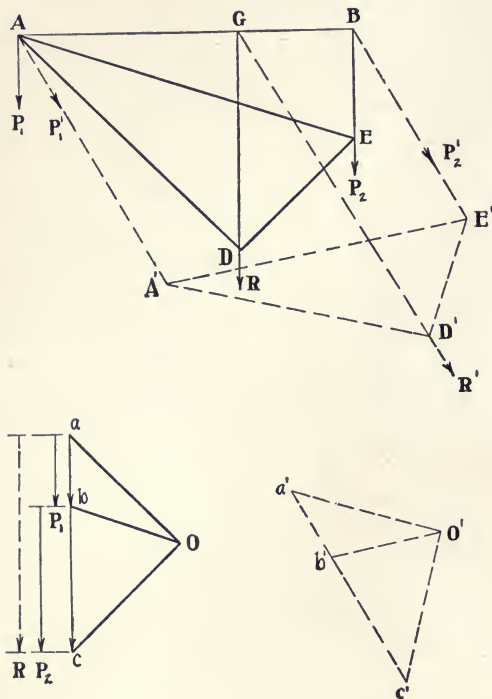

FIG. 41.

Now, revolve the forces P_1 and P_2 about their points of application, forming the system of parallel forces P_1' and P_2' , whose force and equilibrium polygons are $O'a'c'$ and $A'D'E'$, respectively. The resultant R' acts on the line GD' which intersects AB at G . With the same relative locations of the poles O and O' , the construction of the force polygon $O'a'c'$ is unnecessary, since the sides of the equilibrium polygon $A'D'E'$ are at the same angle with the corresponding sides of the polygon ADE as that through which the forces were revolved.

It is evident that, at whatever angle the forces be inclined, if they remain parallel, the line of action of their resultant will

pass through the point G , which is hence the point of application of that resultant. This point is called the *centre of parallel forces* or the *centroid*.

In Fig. 41 the forces have the same direction. If they act in opposite directions and are still unequal in magnitude, their resultant will be equal to the algebraic sum of the forces and will act on a line parallel to their lines of action, meeting AB produced at a point G , as in Fig. 41 *a*, where $R = P_2 - P_1$, and:

$$AG : BG :: P_2 : P_1.$$

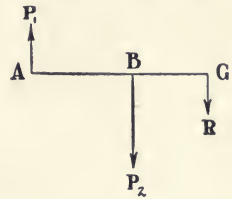

FIG. 41 *a*.

If the forces are equal in magnitude and opposite in direction, they form a couple whose centroid is infinitely distant from the points of application of the forces and on a line drawn through those points.

(*b*) *Centroid of coplanar parallel forces whose points of application are coplanar with all of the forces, but are not in a straight line.* It is evident that, so long as the points of application of parallel forces lie in the same straight line, the centroid of the system will be at the intersection of the resultant with that line, whatever may be the number or relative directions of the forces. When, however, the points of application, although in the same plane, do not lie in the same straight line, the method shown in Fig. 41, *i.e.*, the intersection of the lines of action of resultants, may be used for coplanar forces in determining the centroid of the system.

Thus, Fig. 42, let $P_1 \dots P_4$ be a system of parallel forces having the points of application, A, B, C, D , respectively, these points and the lines of action being in the same plane. Draw the force and equilibrium polygons Oae and $EBFKLH$, respectively; the resultant R acts on the line RHK . Revolve the forces about their points of application, keeping the lines of action still in their original plane. The system $P_1' \dots P_4'$ is

resultant passes, and hence on which, if supported, a rigid body will balance in any position. If any straight line pass through the centre of gravity, the sum of the moments of the forces of gravity, acting on the particles on one side of this line, will be equal to that of those on the other.

The use of the term 'centre of gravity,' as applied to lines or areas which have no mass, is based on the arbitrary assumptions noted below.

29. Centre of Gravity of a Line. It is assumed that the force of gravity acting on the line is proportional to the length of the latter, *i.e.*, that there is an equal force applied at the centre of each unit of length, as if the line were a thin wire.

(a) *Straight line.* The centre of gravity is at the middle of its length.

(b) *Broken line,* as in Fig. 43. The methods of Art. 28 *b* can be used to determine the centroid, since parallel forces proportional to the lengths of the segments *AB*, *BC*, and *CD* are assumed as applied at the respective centres *E*, *F*, and *G* of these segments. This process may be applied also to closed polygons.

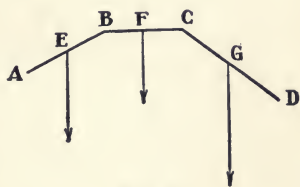

FIG. 43.

(c) *Circular arc.* If a regular polygon be assumed to have an infinite number of sides, it becomes a circle. Hence, on this assumption, the centre of gravity of a portion of the perimeter of a regular polygon may be determined in such a way as to make the method applicable to the corresponding arc of the inscribed circle, and to circular arcs in general.

Thus, Fig. 44, let *abcde* be a portion of the perimeter of a regular polygon; *r*, the radius of the inscribed circle; *AB*, a diameter of this circle drawn perpendicular to the radius *Oc* bisecting *abcde*; *s*, the length of one side of the polygon; *S*, the total length of these sides; $l_1 \dots l_4$, the projections of the sides

upon AB ; L , the total length of these projections; $y_1 \dots y_4$, the distances of the centres of gravity or middle points of the sides from AB ; Y , the similar distance of the centre of gravity of the polygonal circuit $abcde$.

It is assumed that a gravitational force proportional to the length s and perpendicular to the plane of the circuit $abcde$

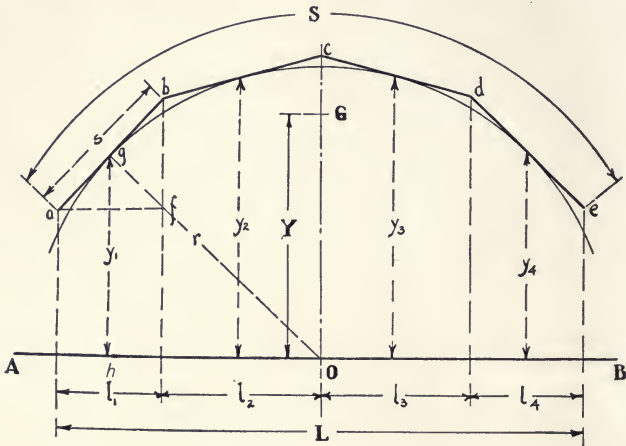

FIG. 44.

acts from the centre of gravity, as g , of each side. There is formed thus a system of parallel and equal forces, whose resultant is S and whose centroid will be the required centre of gravity of the polygonal circuit.

The triangles abf and Ogh are similar. Hence :

$$y_1 : l_1 :: r : s. \quad \therefore y_1 = rl_1/s.$$

Similarly :

$$y_2 = rl_2/s; \quad y_3 = rl_3/s; \quad y_4 = rl_4/s.$$

Taking moments about AB :

$$\begin{aligned} SY &= s(y_1 + y_2 + y_3 + y_4) \\ &= r(l_1 + l_2 + l_3 + l_4); \\ Y &= Lr/S, \end{aligned}$$

which is the distance from AB of the required centre of gravity

of the polygonal circuit, the point G , thus found, being located on the radius Oc , since this radius is the axis of symmetry of the figure.

When the number of sides becomes infinite, $abcde$ is an arc of the inscribed circle, of which arc L and S are, respectively, the chord and the length. Thus, for a semicircle, $L = 2r$, $S = \pi r$, and $Y = 2r/\pi$.

30. Centre of Gravity of Polygonal Areas. It is assumed that the force of gravity acting on the area is proportional to the magnitude of the latter, *i.e.*, that there is an equal force applied to the centre of each unit of area, as if the figure were a thin plate.

(a) *Triangle.* The centre of gravity is at the intersection of the lines drawn from the vertices to the middle points of the opposite sides. Thus, Fig. 45, in the triangle ABC , the line AD drawn from the vertex A to the middle D of the opposite side BC divides the triangular area ABC into two equal parts and also bisects all lines, as aa' , within the area

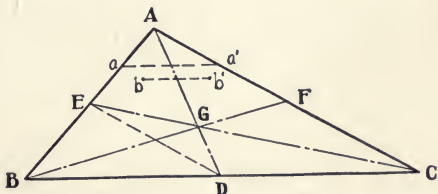

FIG. 45.

and parallel to the base BC . Hence, for every element of area, as b , there must be a corresponding element b' equally distant from AD on a line parallel to BC . The centroid of this pair of elements lies on AD . The entire area consists of an infinite number of such pairs of elements; therefore, the centre of gravity of the entire area lies on the line AD . Similarly, it lies on BF or CE , and is hence at the intersection G of these three median lines. Since $EB = AB/2$ and $BD = BC/2$, the triangles ABC and EBD are similar and $DE = AC/2$. For the same reasons, the triangles GAC and GED are similar, and therefore, as $DE = AC/2$, $DG = AG/2 = AD/3$.

(b) *Parallelograms.* For similar reasons, the centre of gravity of a parallelogram lies at the intersection of a line joining the middle points of one pair of opposite sides and a similar line connecting the other pair. The point thus determined is also the intersection of the two diagonals of the parallelogram.

(c) *Any polygonal area,* regular or irregular, can be divided into triangles and the centres of gravity of the latter located as above; then the centre of gravity of the whole area may be found either as shown in Art. 28 *b*, or by geometrical constructions.

The latter method is followed in Fig. 46 for the quadrilateral area $ABCD$. Draw the diagonal BC , thus dividing the quadrilateral into two triangular areas, ABC and DBC ; connect A and D with the middle point E of BC ,

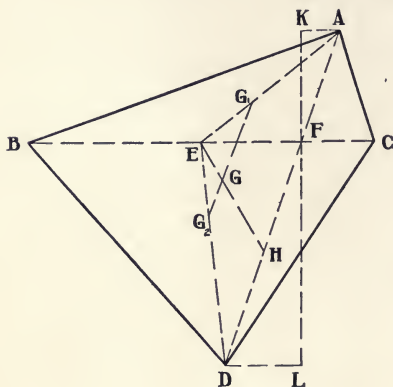

FIG. 46.

and on the median lines, AE and DE , lay off $EG_1 = \frac{1}{3} AE$ and $EG_2 = \frac{1}{3} ED$. The points G_1 and G_2 will then be the centres of gravity of the triangular areas ABC and DBC , respectively, and the centre of gravity of the quadrilateral will lie at the point G on the line G_1G_2 .

of gravity of the quadrilateral will lie at the point G on the line G_1G_2 .

To locate the point G : draw the diagonal AD intersecting BC at F , KFL perpendicular to BC , and AK and DL parallel thereto. The triangles ABC and DBC have the common base BC , and their areas are therefore proportional to their altitudes. Hence:

$$\text{area } ABC : \text{area } DBC :: FK : FL :: FA : FD.$$

Since the line G_1G_2 divides the sides EA and ED of the triangle

EAD into proportional parts, it is parallel to the side AD . Hence (Art. 27 *a*):

$$GG_2 : GG_1 :: FA : FD.$$

Lay off $DH = FA$ and draw EH intersecting G_1G_2 at the point G , which is the centre of gravity of the area $ABCD$.

31. Centre of Gravity of Curvilinear Areas. (a) Circular sector. Let it be required

to find the centre of gravity of the circular sector $OABC$, Fig. 47. The sector is composed of a number of elementary sectors, as Oab . If this number be assumed as indefinitely large, the distance ab becomes indefinitely small

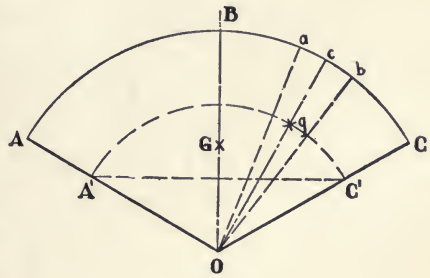

FIG. 47.

and Oab is virtually a triangle whose centre of gravity g lies on the median line Oc at a distance $Og = \frac{2}{3} Oc$ from O . Through g draw the arc $A'C'$ on which are located the centres of gravity of all of the elementary sectors. The centre of gravity G of the entire sector therefore coincides with that of the arc $A'C'$, which point lies on the axis of symmetry OB of the figure at a distance OG from the centre O , which distance can be determined by the methods of Art. 29 *c*.

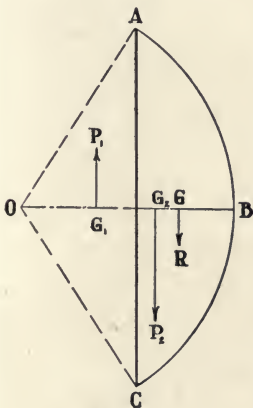

FIG. 48.

(b) *Circular segment.* The area of the circular segment ABC , Fig. 48, is the difference between the area of the sector $OABC$ and that of the triangle OAC . The centres of gravity of the three areas

all lie on the axis of symmetry OB . Let G_1 and G_2 be those of

the areas of the triangle and sector, respectively, and, at these points, let there be applied parallel forces P_1 and P_2 , respectively proportional to the areas. If P_2 be assumed to act downward, then P_1 must have the opposite direction, since the area of the segment is the difference between those of the sector and triangle. The problem is then to find the line of action of the resultant, $R = P_2 - P_1$, which will intersect OB at the point G , the required centre of gravity of the segment. By Art. 26 *a*:

$$G_1G : G_2G :: P_2 : P_1,$$

from which the point G can be located.

32. Centre of Gravity of Compound Areas. When an area can be divided into simple geometrical figures, its centre of gravity is found by assuming a force proportional to the area of

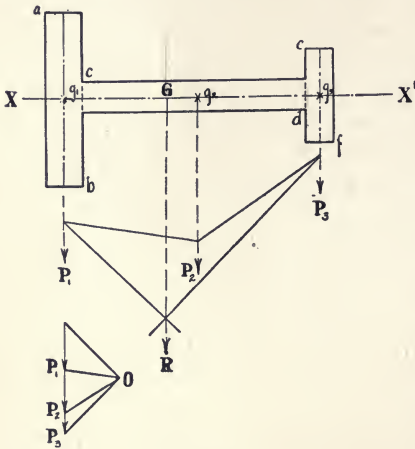

FIG. 49.

each part as applied at the centre of gravity of that part, and then determining the centroid of the system of parallel forces thus formed, which centroid is the centre of gravity of the combined areas. If the total figure is symmetrical about any axis, the centre of gravity will lie on that axis, and but one determination by the force and equilibrium polygons is necessary.

(a) *Symmetrical areas.* Thus, the T-shaped section, Fig. 49, is symmetrical about the axis XX' , on which, therefore, its centre of gravity must lie. Its area can be divided into the rectangles, ab , cd , and ef . Applying the parallel forces P_1 , P_2 , and P_3 , proportional to these rectangular areas, at the centres of gravity of the latter g_1 , g_2 , and g_3 , respectively, and drawing the force

and equilibrium polygons, the resultant R of the forces is found to intersect the axis XX' at the point G , which is the centre of gravity of the section.

Similarly, the channel-shaped section, Fig. 50, is symmetrical about the axis YY' and can be divided into three rectangular areas whose centres of gravity are $g_1, g_2,$ and g_3 , as shown. Since the point g_2 lies on the axis of symmetry of the entire figure, the system $P_1 \dots P_3$ must be assumed at an angle to that axis. Proceeding as in the previous case, the resultant R is found to intersect YY' at the point G , which is the required centre of gravity, although lying beyond the limits of the figure.

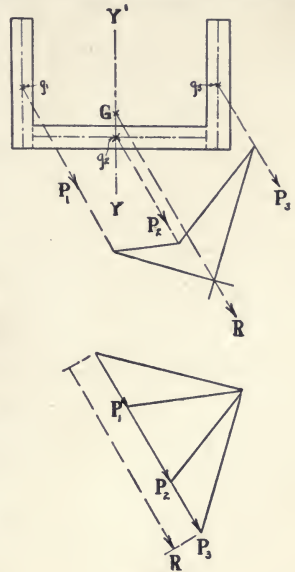

FIG. 50.

(b) *Unsymmetrical areas.* The angle section, Fig. 51, is unsymmetrical, but can be divided into the rectangular areas whose centres of gravity are g_1 and g_2 . Assume parallel vertical forces P_1 and P_2 , acting from these points and proportional to the respective areas. Draw the force polygon Oac , the equilibrium polygon ABC , and the line of action of the resultant R . Then, revolve the forces through an angle of 90° , forming the system P'_1 and

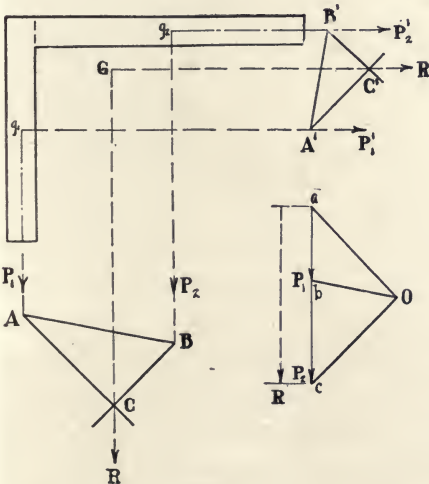

FIG. 51.

P_2' , the sides of whose equilibrium polygon $A'B'C'$ are at right angles to the corresponding sides of the polygon ABC . The line of action of the new resultant R' intersects that of R at the point G , which is the centre of gravity of the section. With the unsymmetrical areas, therefore, the centre of gravity is determined by the intersection of the lines of action of two resultants.

33. Centre of Gravity of Partial Areas. The area of a perforated plate is the total area, less the combined areas of the perforation. The location of the centre of gravity of the partial area remaining after these deductions can be found by the methods of Art. 28 *b*.

Thus, Fig. 52, let it be required to determine the centre of gravity of the partial area, $ABCDEF$, which area is equal to

that of the rectangle $ADEF$, less those of the triangle ABC and the circle g_2K . At the centres of gravity g_1 , g_2 and g_3 of these three figures, apply parallel forces P_1 , P_2 , and P_3 , respectively proportional to the areas, the forces corresponding with the two areas deducted being assumed to act in the opposite direction from

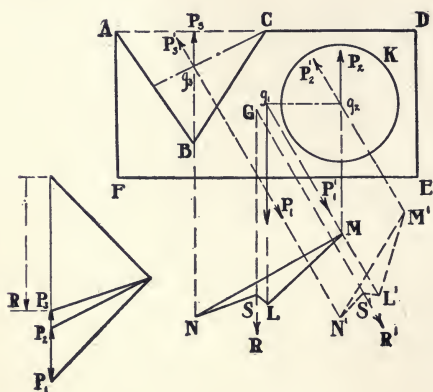

FIG. 52.

P_1 , which represents the area of the rectangle. Draw the force polygon and the equilibrium polygons $LMNS$ and $L'M'N'S'$ for two directions of the system of forces. The resultants R and R' intersect at the point G , which is the centroid of the system and the centre of gravity of the partial area $ABCDEF$.

34. Centre of Gravity of Irregular Areas. The centre of gravity of an irregular area, as shown in Fig. 53, may be found, in close approximation, by drawing

a series of vertical lines, closely and uniformly spaced, which divide the area into strips so narrow that the centre line of each space may be regarded as the length of the strip. At the centre of gravity of each strip, *i.e.*, the middle point of its centre line, apply a vertical force

proportional to the area of the strip. Proceeding as in Art. 28 *b*, find the centroid of this system of parallel forces, which centroid is the centre of gravity of the area.

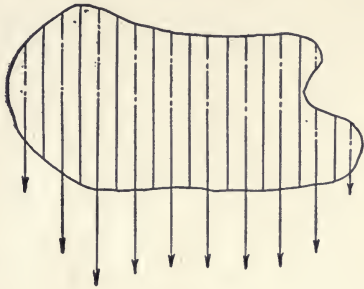

FIG. 53.

PROBLEMS

- 47.** A vertical force of 10 pounds at one end of a 12-foot lever balances a vertical force of 16 pounds at the other end. Find, by the equilibrium and force polygons, the position of the fulcrum and its reaction.
- 48.** Given a simple beam of 12-foot span upon which are concentrated loads of 300, 400 and 500 pounds, at distances of 2, 6 and 8 feet, respectively, from the left support. Determine the reactions at the supports.
- 49.** Forces of 300, 500 and 400 pounds act vertically downward at points 2, 4, and 8 feet from the left extremity of a rod, while forces of 600 and 800 pounds act vertically upward at points 3 and 7 feet from the same end. Find the magnitude of the resultant and its point of application.
- 50.** Replace the resultant of Problem 47 by two parallel components, one of which shall act at 5 feet and the other at 6 feet from the left extremity.
- 51.** Find the equilibrium polygon for a complanar, parallel set of eight equal forces at equal distances apart.
- 52.** The effective length of each arm of a die-stock is 24 inches. Determine the resistance which an iron pipe 1-1/2 inches outside diameter offers to each of the two pairs of thread-cutters, if a man exerts a force of 50 pounds at each end of the die-stock.

53. Find the centroid of the parallel forces 8 and 10 acting at the distance of 12 units apart.
54. Find the centre of gravity of a wire bent into three parts, whose lengths are as 2 : 3 : 4, the adjacent parts being perpendicular to each other.
55. Find the centre of gravity of a circular arc whose length is equal to its radius.
56. Find the centre of gravity of three equal weights placed at the vertices of a triangle whose sides are 6, 8, 10 feet, respectively.
57. Find the centre of gravity of a quadrilateral whose sides are 6, 8, 10, and 12, respectively.
58. Determine the centre of gravity of a circular sector which is one-sixth of the circle.
59. A bridge member has two web plates 18 by $\frac{3}{8}$ inches, top plate 21 by $\frac{3}{8}$, top angles 3 by 3 and $\frac{3}{8}$ inches thick, bottom angles 4 by 3 and $\frac{1}{2}$ inch thick. Find the distance from the centre of gravity to the middle of the section.

CHAPTER V

MOMENTS

GRAPHIC STATICS considers, in general, only the moments of forces with respect to a point and of forces and areas with respect to an axis. Since an area has no mass, the computation of its moment is based on the assumption (Art. 30) that the mass of each element of area is proportional to the area of the element. The moments which are treated herein are: the *first moment*, or simply *the moment*, which is the product of force-units or area-units by length-units, *i.e.*, the distance of the force- or area-units from the point or axis about which moments are taken; and the *second moment*, or *moment of inertia*, which is the product of force-units or area-units by the square of the length-units, as defined above. Article 48 gives, further, the method of obtaining higher moment surfaces.

35. Moment of a Force with Respect to a Point. The moment of a force about a given point is the product of the magnitude of the force by the perpendicular distance or *arm* between its line of action and the given point. The moment is thus a compound quantity. If the force be measured in pounds and its arm in feet, the magnitude of the moment will be expressed in pound-feet; or if kilograms and meters be the units, in kilogram-meters.

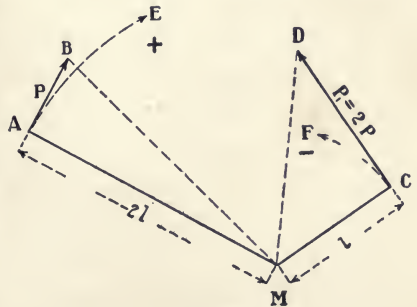

FIG. 54.

In Fig. 54, let the line AB represent a force P in magnitude,

direction, and line of action, and let M be any point and $MA = 2l$ be perpendicular to AB . Then, the moment of the force P with respect to the point M is:

$$AB \times MA = P \times 2l,$$

or, geometrically,

$$= 2 \times \text{area of triangle } MAB.$$

Similarly, the moment of the force $P_1 = 2P$ having the arm l is:

$$\begin{aligned} CD \times MC &= P_1 \times l = 2Pl, \\ &= 2 \times \text{area } MCD. \end{aligned}$$

The magnitude of the moment is hence the same for both forces, since P_1 has twice the magnitude of P with an arm one-half as long. The two moments differ, however, in the tendency of their respective forces to produce rotation. Thus, if M , AB , and CD lie in the same plane of a rigid body, and if M be a fixed centre about which the body may rotate in that plane, then the force P will have a *positive moment*, since it tends to produce clockwise rotation of the body about the point M , and similarly the force P_1 , as it tends to produce contra-clockwise rotation, will have a *negative moment*. This distinction is arbitrary; rotation in either direction may be considered as *positive*, if the same assumption be made throughout any investigation.

If the rigid body be free to revolve about any centre and the force P or P_1 be applied to it, the tendency of either force would be both to rotate the body about its centre of gravity and to produce a motion of translation in the direction of the force, so that, to prevent translation and produce rotation only, there would be required an additional force, the same in magnitude, parallel, and opposite in direction to the first, and so applied as to form a couple. With regard to a fixed centre M , as the *origin of moments*, however, the magnitude of the moment of a force measures the tendency of the force to produce rotation about that point. Hence, as the magnitudes of the moments of

the forces P and P_1 are equal, their tendencies to produce rotation are equal in amount but opposite in direction.

36. Moments of Complanar, Non-parallel Forces with Respect to a Point. In Fig. 55, let $P_1 \dots P_4$ be a system of

complanar, non-parallel forces, and let it be required to find the moments of the several forces about any complanar point as M . Draw the force polygon $a \dots e$ with pole O ; the magnitude and direction of the resultant R are given by the line ae . In the corresponding equilibrium polygon $ABCDE$, the line of action of the resultant

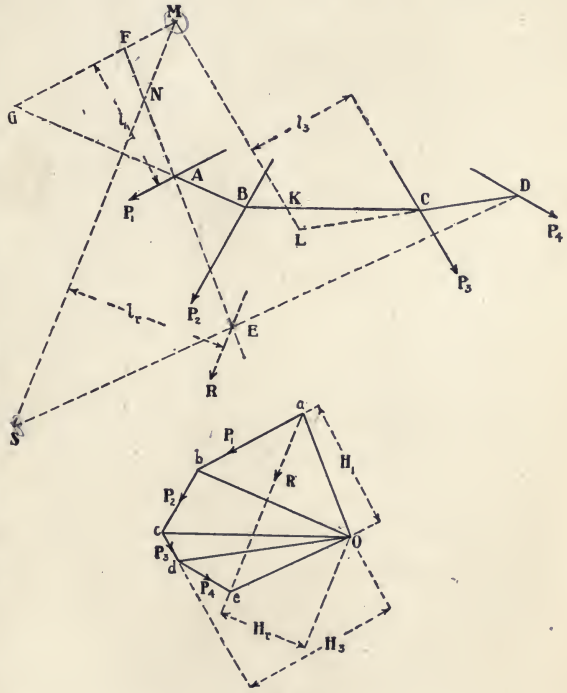

FIG. 55.

passes through the point E , the intersection of the sides AE and DE , which are parallel to the rays Oa and Oe , respectively.

The required moment of any force, as P_1 , is equal to the magnitude of P_1 , *i.e.*, ab , multiplied by the arm or perpendicular distance l_1 between the point M and the line of action of P_1 . Through M draw the line MG parallel to the line of action of P_1 ; from A , the point of intersection of two sides of the equilibrium polygon on the line of action of P_1 , prolong the sides BA and

EA until they meet MG at the points G and F , respectively. Let H_1 be the pole-distance of P_1 in the force polygon, *i.e.*, the perpendicular distance between the pole O and that force. The triangles Oab and AFG are similar. Hence :

$$ab : FG :: H_1 : l_1,$$

$$ab \times l_1 = FG \times H_1,$$

$$\text{moment} = \text{intercept } FG \times \text{pole-distance.}$$

Similarly, the moment of the force $P_3 = cd \times l_3 = \text{intercept } KL \times \text{pole-distance } H_3$. This principle applies to the moment of any force about any point. In general, then :

The moment of a force about a given point is equal to the product of the pole-distance of that force by the intercept which is cut from the line, drawn through the given point and parallel to the line of action of the force, through the prolongation of the two sides of the equilibrium polygon which intersect on the line of action of the force.

The positive or negative character of the moment is evident from the direction of the force with regard to the point M , the moments of P_1 and P_3 being thus both positive. In each case, the magnitude of the moment is obtained by measuring the intercept, as FG , by the *moment-scale*. The graduation of the latter depends, for all forces of the system, first, upon the *linear scale* used in spacing the forces, and, second, upon the *force-scale* employed in laying out the force polygon; for each force it depends also upon the pole-distance corresponding with that force.

For example, in Fig. 55, the linear scale was 5 feet to an inch, and the force-scale was 800 pounds to an inch. For the force P_1 , the pole-distance used for H_1 was $1\frac{3}{4}$ inches = $1\frac{3}{4} \times 800 = 1400$ pounds. Then, the moment-scale by which to measure the actual length of the intercept FG is :

$$\begin{aligned} & \text{linear scale} \times \text{pole-distance} \\ & = 5 \times 1400 = 7000 \text{ pound-feet to an inch.} \end{aligned}$$

In constructing the diagram, P_1 was 1200 pounds and l_1 was $1\frac{3}{4}$ inches = $1\frac{3}{4} \times 5 = 8\frac{3}{4}$ feet on the linear scale. The moment of P_1 about the point M is, therefore, $1200 \times 8\frac{3}{4} = 10,500$ pound-feet, and the actual length of the intercept FG was $1\frac{1}{2}$ inches = $1\frac{1}{2} \times 7000 = 10,500$ pound-feet on the moment-scale, or the same as the computed moment. It will be observed that, with non-parallel forces, the pole-distance differs for each force, giving thus a different moment-scale in each case.

37. Moments of Complanar, Parallel Forces with Respect to a Point. In Fig. 56, let $P_1 \dots P_4$ represent a system of complanar, parallel forces,

and let it be required to find the moments of the several forces about any point, as M . Draw the force polygon $a \dots e$ with pole O ; the magnitude and direction of the resultant R are given by the line ae . In the corresponding equilibrium polygon, $ABCDE$, the line of action of this resultant passes through the point E , the intersection of the sides AE and DE , which are parallel to the rays Oa and Oe , respectively.

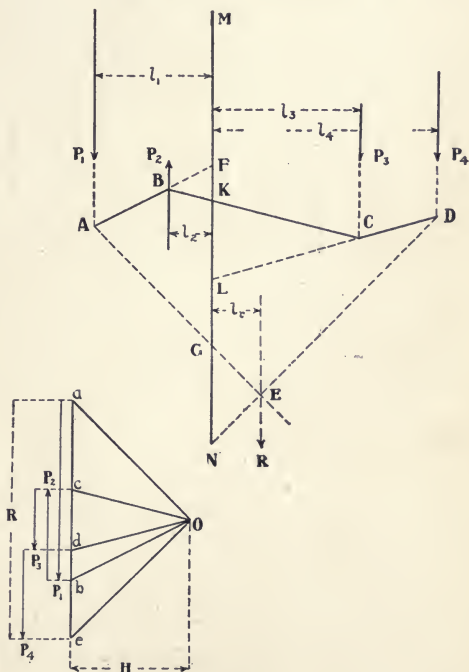

FIG. 56.

Through M draw the line MN parallel to the lines of action of the forces and to that of their resultant. Since the forces

are parallel, the pole-distance H is the same for all of the forces, and, therefore, the same moment-scale applies throughout. By Art. 36, the moment of any force is equal to the intercept cut from the line MN by the sides — produced, if necessary — of the equilibrium polygon which intersect on the line of action of that force. Hence, the moments of the system about the point M are represented by the intercepts :

$$\begin{aligned} FG & \text{ for force } P_1, \\ FK & \text{ for force } P_2, \\ KL & \text{ for force } P_3, \\ LN & \text{ for force } P_4, \\ GN & \text{ for resultant } R, \end{aligned}$$

which intercepts, measured by the common moment-scale computed as described previously, will give the magnitude of the several moments, the latter being all positive except that of P_1 .

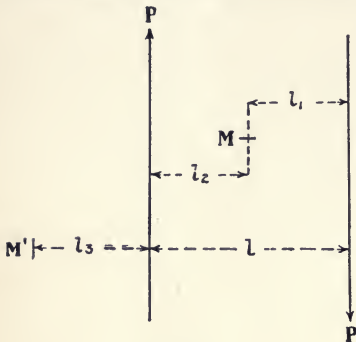

FIG. 57.

38. Moment of a Couple with Respect to Any Point in its Plane.

If, as in Fig. 57, the point M , about which moments are taken, lies between the lines of action of the two equal forces which form the couple, both moments are positive, and :

$$\begin{aligned} \text{moment of right-hand force} &= Pl_1, \\ \text{moment of left-hand force} &= Pl_2, \\ \text{algebraic sum of moments} &= P(l_1 + l_2) = Pl. \end{aligned}$$

Again, if the origin of moments lies outside of the lines of action, as at M' , one moment will be positive, the other negative, and :

$$\begin{aligned} \text{moment of right-hand force} &= +P(l + l_3), \\ \text{moment of left-hand force} &= -Pl_3, \\ \text{algebraic sum of moments} &= Pl, \end{aligned}$$

or the same magnitude as before. Hence, the moment of a couple about any point in its plane is a constant, and is equal to the product of either of the forces composing the couple, by the perpendicular distance between their lines of action.

39. Moment of the Resultant of Any System of Complanar Forces. The moment of the resultant is found by the same method as that given for the individual forces of a system. Thus, in Fig. 56, the line ae in the force polygon gives the magnitude and direction of the resultant R ; the sides AE and DE of the equilibrium polygon, which are parallel to the rays Oa and Oe , respectively, intersect at E , a point on the line of action ER of the resultant; through the origin of moments M , the line MN is drawn parallel to ER ; and the sides AE and DE , which intersect at E , cut the intercept GN from this line. The triangles EGN and Oae are similar. Hence:

$$\begin{aligned} ae : GN &:: H : l_r, \\ ae \times l_r &= GN \times H. \quad \text{i.e.,} \\ \text{moment of } R &= \text{intercept } GN \times \text{pole-distance } H. \end{aligned}$$

Again, as the forces of the system are parallel, the intercept in each case is multiplied by the same pole-distance H , in order to obtain the corresponding moment. All moments are positive except that of P_1 . Hence, the algebraic sum of the moments about the point M is:

$$H(FK + KL + LN - FG) = H \times GN;$$

i.e., the algebraic sum of the moments of the forces is equal to the moment of their resultant, which principle is general.

By similar methods, the moment of the resultant of a system of complanar, non-parallel forces is found, as in Fig. 55. In this case, the pole-distance differs for each force, and that the algebraic sum of the moments is equal to the moment of the resultant must be demonstrated by computation or by the geometrical methods given in works on elementary mechanics.

40. Conditions of Equilibrium. If a system of coplanar forces is in equilibrium, there will be neither a resultant force nor couple produced by their composition. Hence, the algebraic sum of the moments will be zero, which is the condition for equilibrium for moments about any point in the plane of the forces. Conversely, if the algebraic sum of the moments of the forces about any point in their plane be zero, the system will be in equilibrium.

41. Bending Moment. In the examination of the tensile and compressive stresses in beams, the term *Bending Moment* is used to denote the algebraic sum of the moments of the external forces acting on the left of the section of the beam to be investigated, these moments being taken about a point in this section. Since, up to the point of rupture, the system is in equilibrium, the forces to the right have, with respect to the given section, a bending moment of equal magnitude but of opposite sign. In each case, the bending moment simply measures the tendency of the corresponding external forces to produce rotation about a point in the section considered. The bending moment is a compound quantity which may be expressed in pound-inches, pound-feet, ton-feet, etc.

Thus, Fig. 58, consider a 'simple beam,' — *i.e.*, one resting upon two supports, one at each end, — as AB , carrying the loads $P_1 \dots P_4$, and supported by the reactions R_1 and R_2 . Construct the force and equilibrium polygons $abcde$ and $CDEFGH$, respectively; draw the ray O_f parallel to the closing side HC , thus determining the magnitude of the reactions R_1 and R_2 . Now, let it be required to find the bending moment at a point M in the section of the beam cut by the line MNQ , which line is parallel to the lines of action of the forces.

This moment is, by definition and by Art. 39, the moment of the resultant r of the forces to the left of M ; *i.e.*, of the forces P_1 and R_1 . The magnitude and direction of the resultant r are

given by the line fb in the force polygon; by Art. 21, the sides CH and DE , which are cut by the line MNQ , intersect, when prolonged, at a point L in the line of action of r . From L drop the perpendicular of length l on the line MNQ . Then,

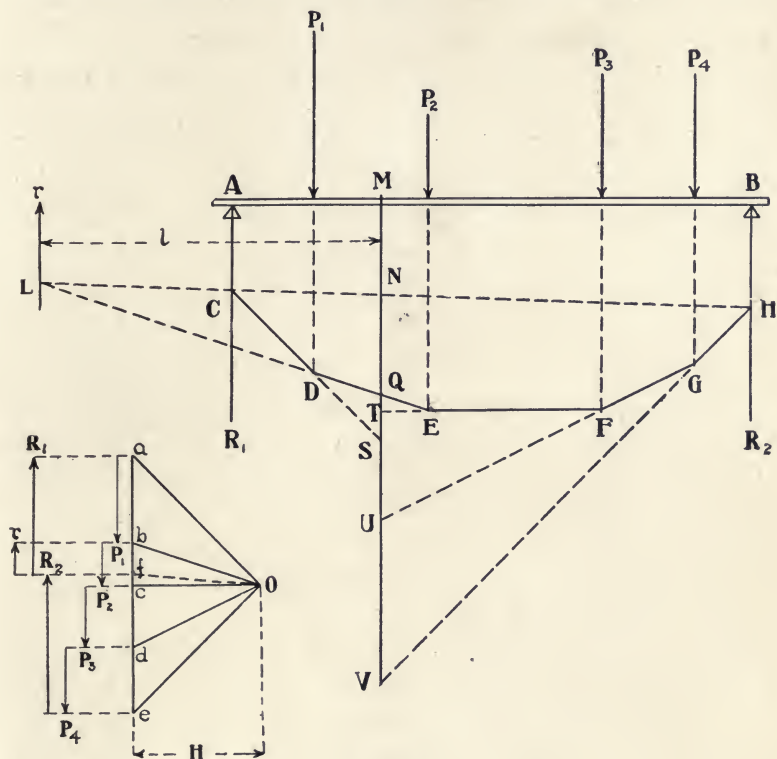

FIG. 58.

the bending moment at the point M is equal to $r \times l$, and, by Art. 37, it is also equal to the intercept $NQ \times$ the pole-distance H , since the sides LH and LE of the new equilibrium polygon $LEFGH$, formed by the composition of P_1 and R_1 into their resultant r , intersect on the line of action of r and also cut the intercept NQ from the line MNQ . This principle is general when the lines of action of the forces and reactions are parallel.

Under these conditions :

The bending moment in any section parallel to the lines of action of the forces is directly proportional to the corresponding ordinate of the equilibrium polygon, and is equal to the product of that ordinate by the pole-distance in the force polygon. If the pole-distance is made equal to the unit of force, the ordinate of the equilibrium polygon represents the magnitude of the bending moment.

By similar methods, it can be shown that the bending moment of the external forces to the right of the section at M is also equal in magnitude to the intercept $NQ \times$ the pole-distance, or, disregarding the resultant of the forces in both cases, we have, for the moments about M of :

$$R_1 = + NS \times H$$

$$P_1 = - QS \times H$$

$$\text{Algebraic sum of moments to left of } M = + NQ \times H$$

$$P_2 = + QT \times H$$

$$P_3 = + TU \times H$$

$$P_4 = + UV \times H$$

$$R_2 = - NV \times H$$

$$\text{Algebraic sum of moments to right of } M = - NQ \times H$$

i.e., the bending moment at the right of the section at M is equal in magnitude to that on the left, but with contrary sign.

The bending-moment scale, by which to measure the ordinates of the equilibrium polygon, is computed by the methods of Art. 36.

42. Combined Bending Moments. Since the bending moment, or any statical moment, may thus be represented, like a simple force, by a line, these moments may be combined or resolved by the same methods as in the case of forces.

(a) *Moments in the same plane.* In Fig. 59 let there be two equal and parallel forces P_1, P_2 applied to a simple beam. The upper equilibrium polygon or *bending-moment diagram* considers the left-hand force P_1 only; the second diagram, the

right-hand force only; and the final diagram includes both forces. The three force polygons are constructed with the same pole-

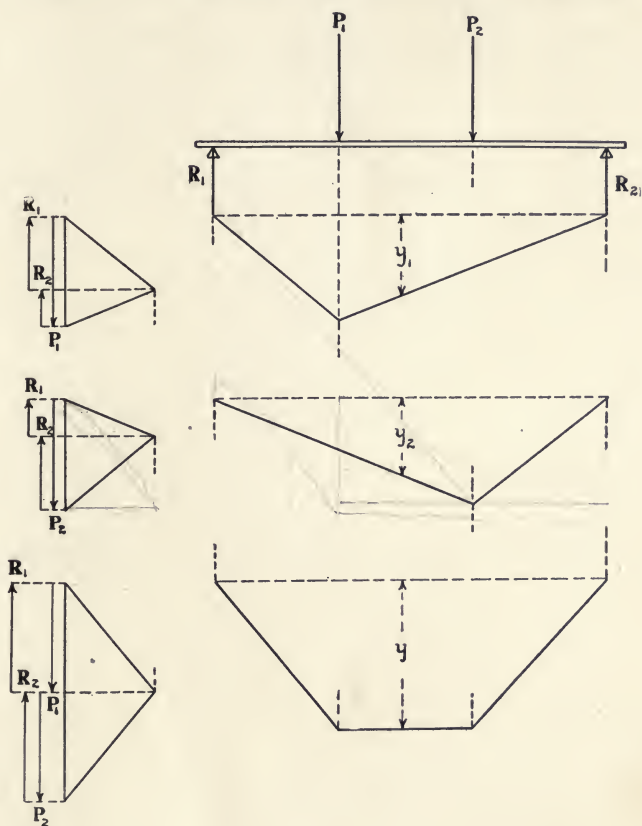

FIG. 59.

distance. Any ordinate, as y , in the lower diagram is the arithmetical sum of the corresponding ordinates y_1 and y_2 in the two upper diagrams. In this case, bending moments in the same plane have been treated like forces having the same line of action, and added to find the resultant moment. The principle is general for all bending-moment diagrams under these conditions. In Fig. 59 both forces have the same direction; if one

had acted upward and the other downward in the same plane, the two moments would have had different signs and the resultant moment would have been their algebraic sum.

(b) *Moments in planes inclined to each other.* In Fig. 60 assume the force P and the weight W to be acting normally to the neutral axis (Art. 61) of the beam, the line of action of the force being inclined at an angle θ with the vertical. Revolve the force into a vertical plane as the force P' ; draw the force polygons

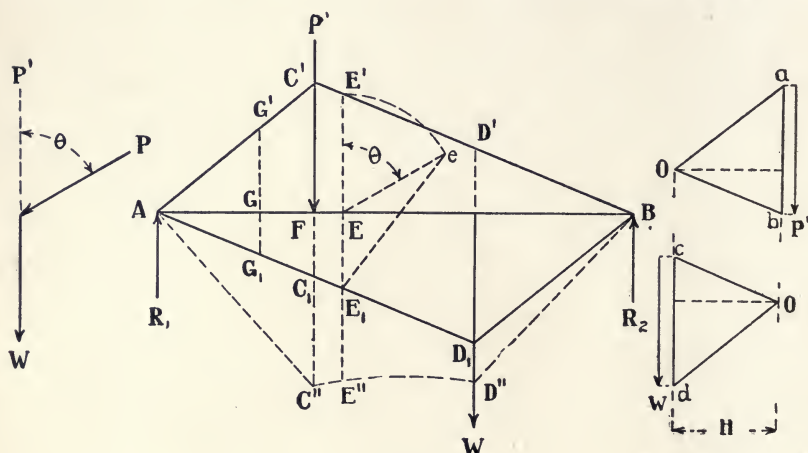

FIG. 60.

ab and cd with the same pole-distance; and construct the corresponding equilibrium polygons $AC'B$ and AD_1B , which, for clearness, will be located, one above and one below the neutral axis AB .

By Art. 41 the ordinates EE' and EE_1 , corresponding with any point E in the beam, are proportional to the bending moments at that point due to the force P' and the weight W , respectively. The bending moment caused by P' is the same in magnitude as that due to P , although acting at a different angle. Treating the moments as if they were forces, it is necessary only to find the resultant of the two moments of any given point, in order to determine the ordinate at that point of the diagram for the combined moments.

Therefore, revolve the ordinate EE' through the angle θ to Ee , and eE_1 will then represent the resultant of eE and EE_1 . From E lay off downward $EE'' = eE_1$, thus obtaining the point E'' in the diagram for the combined moments; other points are plotted in a similar way, the complete diagram being $AC''D''B$. The portions of the original polygons to the left of the line $C'C$ are triangles having the common altitude AF . Hence, any corresponding ordinates, as GG' , GG_1 , are proportional to the respective bases of these triangles, $GG'/GG_1 = \text{a constant}$, and AC'' , and similarly BD'' , are straight lines. Between $C'C$ and $D'D$, the portions of the polygons are trapezoids, making the side $C''E''D''$ a curve.

43. Moment of a Force with Respect to an Axis. The moment of a force about an axis is the product of the magnitude of the force by the common perpendicular between the axis and the line of action of the force. Thus, Fig. 61, if the line of action AB of the force P lie in the plane of the paper, and if, at C , an axis pass through that plane perpendicular to the latter, then CD , which lies in the plane and is the common perpendicular to the line of action and the axis, is the arm of the force with respect to the axis. The moment of the force $= P \times CD = 2 \times \text{area } ABC$. With respect to a given axis, this moment depends upon both the direction and the point of application of the force.

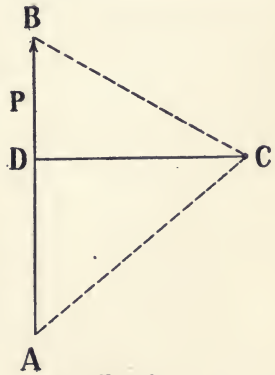

FIG. 61.

44. Moment of an Area with Respect to an Axis in its Plane; Centre of Gravity. The first moment of an area about an axis in its plane is equal to the magnitude of the area, multiplied by the perpendicular distance of its centre of gravity from the axis, since the centre of gravity (Art. 28) is the point at which the

mass of a body is assumed to be concentrated. This moment may be found, and the centre of gravity determined, by the principle of moments, as follows:

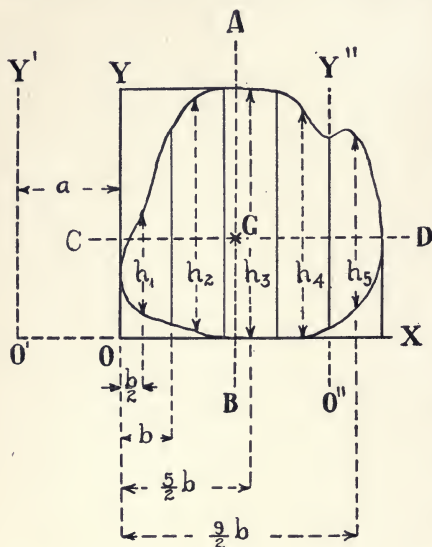

FIG. 62.

(a) *By computation.*

Taking the simplest case, let it be required to determine the moment of the irregular area, Fig. 62, about an axis OY in the plane of the area and tangent to its periphery. Divide the area into any number of strips, parallel to OY and of an equal breadth b , so narrow that the length of the centre-line, as h_1 , of each strip may be taken as the mean height of the latter, and as passing through

its centre of gravity. The areas of the strips and their moments about OY are:

	AREA	MOMENT
<i>First strip</i>	bh_1	$bh_1 \times \frac{1}{2}b$
<i>Second</i>	bh_2	$bh_2 \times \frac{3}{2}b$
<i>Third</i>	bh_3	$bh_3 \times \frac{5}{2}b$
<i>Fourth</i>	bh_4	$bh_4 \times \frac{7}{2}b$
<i>Fifth</i>	bh_5	$bh_5 \times \frac{9}{2}b$

Since the moment of the resultant of a system of forces is the algebraic sum of the moments of the forces:

$$\text{Moment of area about } OY = \frac{1}{2}b^2(h_1 + 3h_2 + 5h_3 + 7h_4 + 9h_5).$$

Again, if, as is assumed above, each strip-area represents a force proportional to that area, the resultant of these forces will act through the centre of gravity of the total area; and, further, the

moment of this resultant, divided by its magnitude, will give its arm, or distance, from the axis OY . Hence, the perpendicular distance of the centre of gravity, G , of the entire area from OY , is:

$$\frac{\text{Moment of area}}{\text{Area}} = \frac{b(h_1 + 3h_2 + 5h_3 + 7h_4 + 9h_5)}{2(h_1 + h_2 + h_3 + h_4 + h_5)} = x.$$

The centre of gravity is thus found to be on the line AB , parallel to, and at a distance x from, the axis OY . To determine the position of G on this line, draw the axis OX , divide the area into strips parallel to it, and find the distance y which is equal to the moment of the total area about OX divided by that area. This shows G to be on the line CD , parallel to, and at a distance y from, the axis OX , or at the intersection of the lines AB and CD .

If the axis OY were moved the distance a to the left, as at $O'Y'$, the moments of the strips would become $bh_1(a + \frac{1}{2}b)$,

$bh_2(a + \frac{3}{2}b)$,

etc., and the distance x

would be greater by

the amount a .

Again, if the axis

pass through the

area, as at $O''Y''$,

the moments of the

strips to the left

would be negative;

those to the right,

positive; and their

algebraic

sum would give the

moment of G about $O''Y''$.

(b) *By graphic methods.*

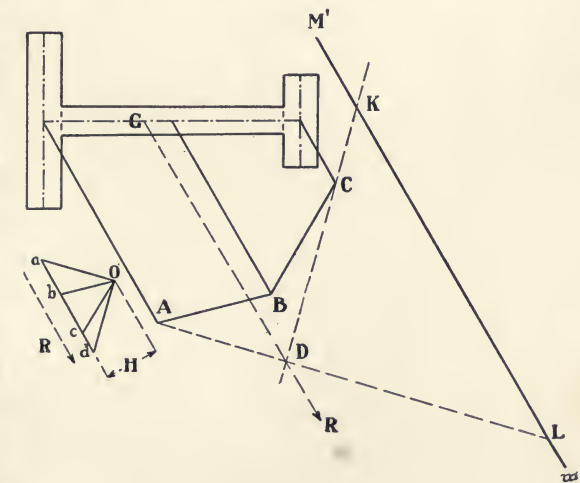

FIG. 63.

The determination of the centres

of gravity of various areas has been discussed in Arts. 30 to 34, inclusive; the moment of any area about an axis in its plane (except one passing through the centre of gravity, about which the moment is zero) may be found by the application of the methods of Art. 39 to those described in these articles.

Thus, Fig. 63, let it be required to find the moment of the area of the T-section about the axis $M'm'$. Construct the equilibrium polygon, as in Art. 32 *a*, with the lines of action of the forces parallel to $M'm'$; by Art. 39, the product of the intercept KL , cut from $M'm'$ by the sides AD and CD prolonged, and the pole-distance H is the magnitude of the required moment. This follows, since the resultant R , acting through the centre of gravity G , represents the entire area, and $KL \times H$ is the moment of that resultant about any point in the axis $M'm'$, and therefore about that axis.

45. Moment of Inertia; Radius of Gyration. (*a*) *Moment of inertia.* If a particle of mass m be rotating, with an angular velocity v , in a plane about a point lying in the plane and at a distance r from the particle, the angular momentum of the particle will be mvr^2 , and that of all the particles composing the body will be $v\Sigma mr^2$. The expression $\Sigma mr^2 = I$ is the sum of the *second moments* or *moments of inertia* of the particles, as defined at the beginning of this chapter, m being the quotient of W , the weight, divided by g , the acceleration of gravity. The term 'moment of inertia' was used primarily with regard to the rotation of rigid bodies. Since, in the mechanics of engineering, force is taken as the product of mass by acceleration, this term may be used to describe the second moment of a force or system of forces about an axis; as an area, however, is not a material body, the term is strictly applicable to it only on the assumption that each element of area has a mass proportional to its area, as if the given figure were a thin plate.

In the expression for I , as given above, the radius r evidently

differs for each particle considered. Hence, the *moment of inertia of a body* is the summation of the products of the masses of the elements of the body by the squares of their respective distances from the *axis of inertia* about which the body is assumed to rotate. Similarly, the *moment of inertia of a force* about such an axis is the product of the squares of the distance between the point of application of the force and the axis, by the magnitude of the force; and the *moment of inertia of a system of parallel forces* is the sum of these products. The *moment of inertia of an area* is, in the same way, the summation of the products of each elementary area, considered as a mass, by the square of its distance from the axis of inertia.

(b) *Radius of gyration.* The radius of gyration is the perpendicular distance from the axis of inertia to the *centre of gyration*. For a body, the centre of gyration is the point at which, if the entire mass of the body were concentrated in a single particle, the effect of the forces acting on the body would be unchanged and the moment of inertia of the body would remain the same.

The distinction between the centre of gyration and the centre of gravity should be noted. The centre of gravity of a body is the mass-centre; its position in the body is invariable; its distance from a given plane is equal to the mean distance of all of the particles of the body from that plane; its distance from an axis is equal to the first moment of the body about that axis, divided by the mass of the body. The centre of gyration of a body, on the contrary, has not an unchangeable location. Its position may be taken as that of any point in the body which, under the conditions then existing, is at a distance from the axis equal to the radius of gyration; with any variation in the virtual centre about which the body revolves, that radius changes also and with it the location of the centre of gyration.

If we assume the entire mass of the body to be concentrated at the centre of gyration, at a distance $k =$ the radius of gyra-

tion from the axis, then the moment of inertia of the body about that axis is :

$$I = \Sigma mr^2 = k^2 \Sigma m.$$

Hence :

$$k^2 = I/\Sigma m;$$

i.e., the square of the radius of gyration is equal to the moment of inertia of the body divided by its mass. Similarly, the square of the radius of gyration of a system of parallel forces is equal to the moment of inertia of the system, divided by the magnitude of the resultant R of the forces, *i.e.*, $k^2 = I/R$. For an area A , by similar reasoning, $k^2 = I/A$.

(c) *Parallel axes of inertia, one passing through the centre of gravity.* Since the moment of inertia of an area is the sum of the second moments, about the axis of inertia, of all of the elementary areas, its moment of inertia about an axis passing through its centre of gravity is the sum of the second moments about that axis of the two sections into which the axis divides the area. This reasoning applies also to the moments of inertia of a body or of a system of parallel forces about such an axis.

The moment of inertia of a system of parallel forces, about an axis passing through the centroid of the system, can be determined graphically with accuracy, since such a system consists of a relatively small number of elements. The graphic determination of the moment of inertia of an area or of a body, about an axis passing through the centre of gravity, is, however, — except under certain conditions to be given later, — but approximate, since the area or the body consists of an infinite number of

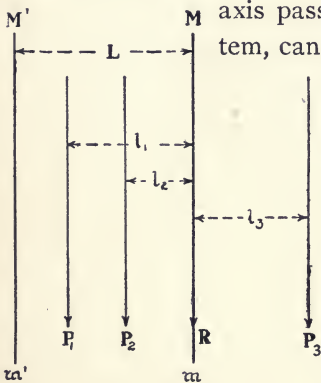

FIG. 64.

elementary areas or elementary masses, the summation of whose second moments is required. Such operations can only be performed with full accuracy by the methods of the calculus.

When, however, the moment of inertia of an area, about an axis passing through its centre of gravity, is known, its moment of inertia about any parallel axis of inertia can be readily found, since there are definite relations between the two moments. Thus, Fig. 64, let $P_1 \dots P_3$ be a system of parallel forces, the line of action of whose resultant R forms an axis Mm passing through the centroid of the system. Let $l_1 \dots l_3$ be the respective distances of the lines of action of the forces from the axis Mm ; let $M'm'$ be any axis parallel to Mm , at the distance L therefrom; and let I be the moment of inertia of the system about the axis Mm , and I' that about $M'm'$. Then:

$$\begin{aligned} I' &= P_1(L - l_1)^2 + P_2(L - l_2)^2 + P_3(L + l_3)^2, \\ &= P_1(L^2 + l_1^2 - 2Ll_1) + P_2(L^2 + l_2^2 - 2Ll_2) + P_3(L^2 + l_3^2 + 2Ll_3), \\ &= P_1(l_1^2 + l_2^2 + l_3^2) + L^2(P_1 + P_2 + P_3) + 2L(P_3l_3 - P_2l_2 - P_1l_1). \end{aligned}$$

In the last equation, the first term = I ; the second term = RL^2 ; and, in the third term, $P_1l_1 \dots P_3l_3$ are the first moments of the forces about an axis passing through the centroid, the algebraic sum of which moments is zero (Art. 40), since the forces on one side of the resultant balance those on the other. Hence, the third term vanishes and:

$$I' = I + RL^2.$$

By similar reasoning, for a body and an area, respectively:

$$I' = I + ML^2,$$

$$I' = I + AL^2,$$

in which M and A are the total mass and the total area, respectively. Hence:

The moment of inertia of a body, an area, or a system of parallel forces about any given axis is equal to the moment of inertia of the body, area, or system, respectively, about a parallel axis passing through the centre of gravity or centroid, plus the moment of inertia of the mass of the body, of the area, or of the resultant of the forces, respectively, about the given axis, the mass or area being considered as applied at their respective centres of gravity, and the resultant as acting from the centroid of the system.

As an example, consider the rectangular area, Fig. 65, of base B and height H , and let the axes of inertia be Mm , passing through the centre of gravity,

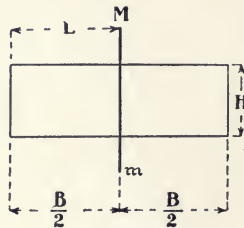
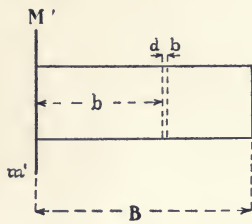

FIG. 65.

and $M'm'$ at the left-hand extremity of the area. Let db be the width of an indefinitely

small element of the area and b its distance from $M'm'$. Then, the moment of inertia of the entire area about the axis $M'm'$ is:

$$I' = H \int_0^B b^2 db = HB^3/3.$$

The axis Mm divides the area into two equal rectangles, each having the base $B/2$. Evidently each of these rectangles may be regarded as revolving about the axis Mm ; the moment of inertia of each section will then be similar to that of the entire area about $M'm'$; and the moment of inertia of the whole figure about Mm will be the sum of those of its two sections about this axis. Hence:

$$I = 2 [H(B/2)^3/3] = HB^3/12.$$

Superposing the figures, the distance L between the two axes will be $B/2$ and the area of the entire rectangle will be BH . Hence:

$$\begin{aligned} I' &= HB^3/3 \\ &= HB^3/12 + HB^3/4 \\ &= I + AL^2. \end{aligned}$$

For I' the radius of gyration is:

$$k = \sqrt{I'/A} = B\sqrt{3}.$$

For I :

$$k = \sqrt{I/A} = B\sqrt{12}.$$

46. Moment of Inertia of a System of Complanar, Parallel Forces. (a) *By the method of intercepts.* Let $P_1 \dots P_3$, Fig. 66, be a system of complanar, parallel forces, acting from the points of application, A , B , and C , respectively, and let it be required to find the moment of inertia of the system about the parallel and complanar axis $M'm'$.

To find the first moment, draw the force polygon $a \dots d$ with pole-distance H , and the corresponding equilibrium polygon, $DEFG$; the resultant $R = ad$ and its line of action passes through the point G . The intercept on the axis $M'm'$ of the sides DE and DG , which intersect on the line of action of P_1 , is $a'b'$, and the first moment of this force about this axis is therefore $a'b' \times H$. Similarly, the first moment of P_2 is $b'c' \times H$, and that of P_3 is $c'd' \times H$. The moment of P_1 is negative, while those of P_2 and P_3 are positive. Hence, the first moment of the resultant R is $(b'c' + c'd' - a'b')H = a'd' \times H$.

To determine the moment of inertia, assume that the first moments, as found above, are a system of forces, each moment acting on the line of action of its original force in the system, $P_1 \dots P_3$. Since the magnitude of each of the first moments is equal to the product of its intercept on the axis $M'm'$ by the pole-distance H , these intercepts may be taken as proportional to, and representing, the new system of forces, in magnitude and direction. Therefore, draw the force polygon $b' \dots d'$, with pole-distance H' , for the forces represented by the intercepts, $a'b'$, $b'c'$, and $c'd'$, and construct the corresponding equilibrium polygon $D'E'F'G'$; the resultant of this assumed system is $R' = a'd'$ and its line of action passes through the point G' . The intercepts of the new forces $a'b'$, $b'c'$, and $c'd'$ on the axis $M'm'$ are, respectively, $a''b''$, $b''c''$, and $c''d''$. All of the moments represented by these intercepts are positive, since the assumed force $a'b'$ acts in a direction opposite to that of P_1 .

As the first moment of any system of forces is equal to the

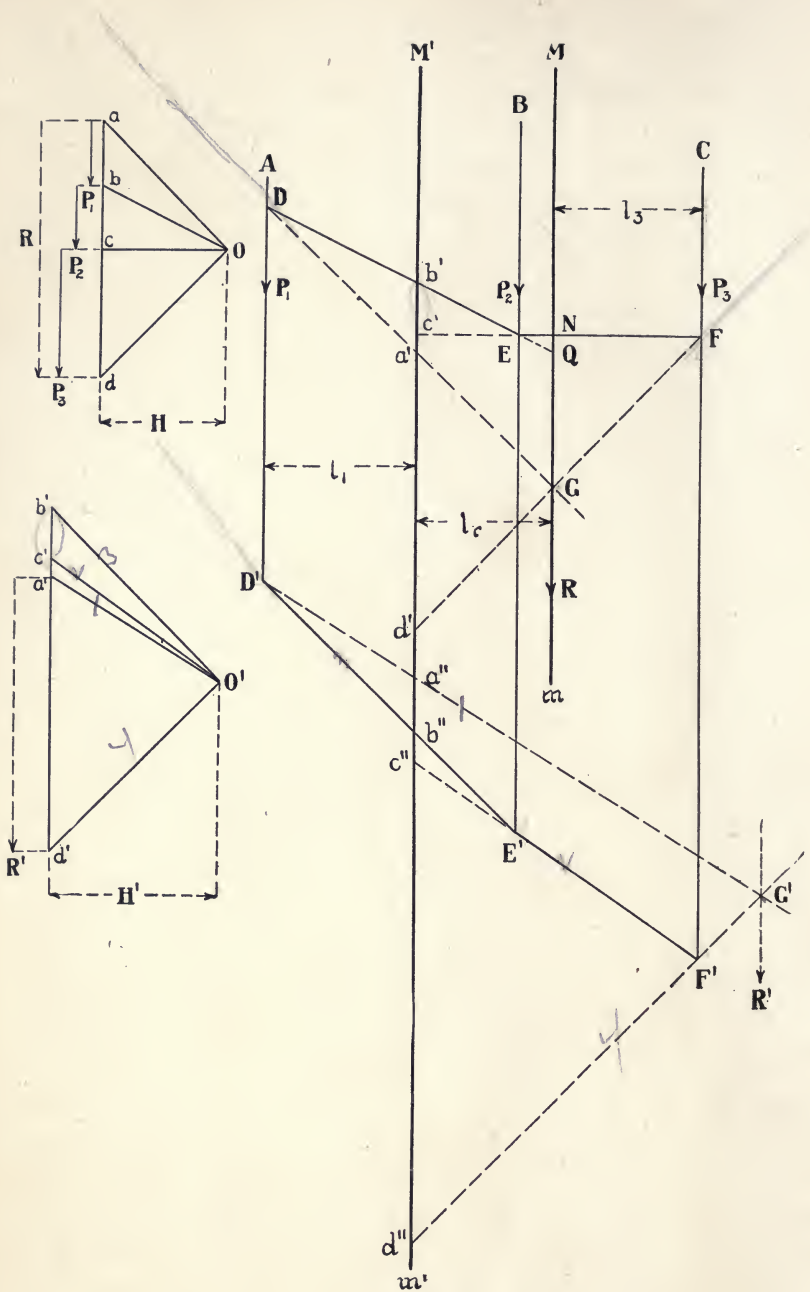

FIG. 66.

first moment of the resultant of the system, the first moment of the resultant R' is the first moment of the assumed system, $a'b'$, $b'c'$, etc., and, hence, is also the second moment of the original system, $P_1 \dots P_3$. The latter moment, which is the moment of inertia required, is hence:

$$a''d'' \times H' \times H.$$

The geometrical proof of this method is as follows:

Let l_1 be the perpendicular distance between the line of action of the force P_1 and the axis $M'm'$. Then, the second moment of P_1 is $P_1 \times l_1^2 = ab \times l_1^2$. The triangles Oab and $Da'b'$ are similar. Hence:

$$\begin{aligned} ab : a'b' &:: H : l_1, \\ ab \times l_1 &= a'b' \times H. \end{aligned}$$

The triangles $O'a'b'$ and $D'a''b''$ are similar. Hence:

$$\begin{aligned} a'b' : a''b'' &:: H' : l_1 \\ a'b' &= a''b'' \times H' / l_1. \end{aligned}$$

Substituting,

$$ab \times l_1^2 = a''b'' \times H \times H'.$$

Similarly, the second moments of the forces P_2 and P_3 are found to be the intercepts, $b''c''$ and $c''d''$, respectively, each multiplied by the two pole-distances. The sum of the three second moments is the moment of inertia of the system; *i.e.*, $a''d'' \times H \times H'$.

The methods of Art. 36 may be applied for the construction of a second-moment scale, by which the moments of inertia may be read directly from the intercepts $a''b''$, $b''c''$, etc. Thus, let the linear scale, by which the forces are spaced, be 5 feet to an inch; the force-scale, by which the polygon $a \dots d$ is laid out, be 800 pounds to an inch; and let the actual length of H be $1\frac{1}{8}$ inches, or $1\frac{1}{8} \times 800 = 900$ pounds. Then, the first-moment scale = linear scale $\times H = 5 \times 900 = 4500$ pound-feet. To find the second-moment scale, the units in which the moment is obtained should be noted. Thus, P_1 is given in pounds and l_1

in feet; the second-moment, $P_1 \times l_1^2$, will, therefore, be in pound-feet² units. Again, the intercepts $a'b'$, $b'c'$, etc., since they were derived from an equilibrium polygon, or *space-diagram*, are really distances and not forces, although they were assumed to be the latter in constructing the polygon $O'b'd'$. Hence, H' , whose actual length was $1\frac{1}{2}$ inches, should be measured by the linear scale, and becomes $1\frac{1}{2} \times 5 = 7\frac{1}{2}$ feet. Therefore, the second-moment scale = first-moment scale $\times H' = 4500 \times 7.5 = 33,750$ pound-feet². Thus, $P_1 = 450$ pounds and $l_1 = 6.9$ feet; the second moment will therefore be 21,425 pound-feet², and, since

$$33,750 : 21,425 :: 1 : 0.63,$$

the actual length of the intercept $a''b''$ was, in the original figure, 0.63 inch.

The square of the radius of gyration is equal to the magnitude of the intercept $a''d''$, measured by the second-moment scale, divided by the resultant $R = ad$, in pounds. The square root of this quotient is the value of k in feet.

(b) *From the area of the equilibrium polygon.* To find the moment of inertia of the system of parallel forces, Fig. 66, from the area of the equilibrium polygon, consider first the moment about the axis Mm , which is the line of action of the resultant R and hence passes through the centroid of the system. For any of the forces, the sides of the polygon which intersect on its line of action and the intercept of these sides on the axis form a triangle, as FGN for the force P_3 , to which there is a similar triangle, as Ocd , in the force polygon. Let l_3 be the distance between the line of action of P_3 and the axis Mm . Then :

$$cd : GN :: H : l_3.$$

$$\text{Since } cd = P_3, \quad P_3 l_3 = H \times GN.$$

$$\text{Multiplying by } l_3: \quad P_3 l_3^2 = 2H(GN \times l_3/2).$$

$P_3 l_3^2$ is the moment of inertia I for the force P_3 about the

central axis Mm , and $Gn \times l_3/2$ is the area of the triangle FGN . By similar reasoning:

$$2 H \times \text{area of triangle } DGQ = I \text{ for } P_1,$$

$$2 H \times \text{area of triangle } ENQ = I \text{ for } P_2.$$

The triangular areas:

$$DGQ + ENQ + FGN = \text{polygonal area } DEFG.$$

Let the area of the equilibrium polygon = A' . Then:

$$A' \times 2 H = I \text{ for } (P_1 + P_2 + P_3) = I \text{ for } R,$$

and for the system. If $H = R/2$:

$$I = A'R,$$

and the square of the radius of gyration is:

$$k^2 = A'.$$

In Fig. 66, the forces $P_1 \dots P_3$ have all the same direction. If one of them, as P_2 , had a direction opposite to that of the other two forces, its moment and the corresponding triangular area would have the opposite sign, and the area A' of the equilibrium polygon would then be equal to the algebraic sum of the three triangular areas.

Consider now the moment of inertia of the system with respect to the parallel axis $M'm'$. The triangles $Da'b'$ and Oab are similar. Hence:

$$ab : a'b' :: H : l_1,$$

$$P_1 \times l_1 = H \times a'b',$$

$$P_1 l_1^2 = 2 H(a'b' \times l_1/2).$$

Hence, the moment of inertia I' for the force P_1 is equal to $2 H \times \text{area of triangle } Da'b'$. Similarly:

$$I' \text{ for } P_2 = 2 H \times \text{triangular area } Eb'c',$$

$$I' \text{ for } P_3 = 2 H \times \text{triangular area } Fc'd'.$$

Let the area of the triangle $Ga'd' = A''$. Then the moment of inertia of the system is:

$$\begin{aligned} I' &= 2 H \times \text{polygonal area } DEFGd'a' \\ &= 2 H(A' + A''). \end{aligned}$$

$$\text{If } H = R/2, \quad I' = R(A' + A''),$$

and the square of the radius of gyration is

$$k^2 = A' + A''.$$

Hence, for an axis passing through the centroid, the moment of inertia is equal to the product of the resultant by the area of the equilibrium polygon, if the pole-distance H be made equal in magnitude to one-half of that resultant. For a parallel axis, the magnitude of this moment is increased by the product of the resultant by the triangular area formed by the sides intersecting on the line of action of the resultant and the intercept of these sides on the given axis.

This relation between the two moments of inertia may also be established by the principles of Art. 45 *c*, from which we have:

$$I' = I + Rl_r^2,$$

in which l_r is the distance from the line of action of R to the axis $M'm'$. The triangles $Ga'd'$ and Oad are similar. Hence:

$$\begin{aligned} ad : a'd' &:: H : l_r, \\ Rl_r &= H \times a'd' = R/2 \times a'd', \\ Rl_r^2 &= R(a'd' \times l_r/2) = A''R, \end{aligned}$$

which is the increase in the moment of inertia as found by the first method.

47. Moment of Inertia of an Area. The determination, with absolute accuracy, of the moment of inertia of a plane area by either of the methods of Art. 46 is impossible, since such an area consists of an indefinitely large number of elements of area, and the corresponding system of parallel forces would therefore be composed of an indefinitely large number of forces, thus making graphic methods unavailable, although the general principles of the latter, as demonstrated for parallel forces in Art. 46, are fully applicable to areas.

(*a*) *Approximate determination.* A working approximation, which will serve in most cases in practice, may be made by first

determining the centre of gravity of the given area; then dividing the latter into a number of narrow strips parallel to a complanar axis passing through the centre of gravity; and finally applying at the centre of gravity of each strip a force proportional to its area, the whole forming a system of complanar, parallel forces which may be treated by the methods of Art. 46. The greater the number of these strips and hence the less their width, the nearer the approximation approaches accuracy.

Thus, Fig. 66, if the forces represented elements of area and there were an infinite number of these forces, the width of each elementary area would be the infinitely small differential of the distance of the forces from the axis, as dl_3 for the force P_3 , and the moment of inertia of each element of area would be that of the corresponding force, as $P_3 l_3^2$ for the force P_3 , about the axis Mm . With an infinite number of such forces, it is evident that the upper sides DEF of the equilibrium polygon would be replaced by a curve tangent to the lower sides DG and FG . In practice, if the given area be divided into a reasonably large number of strips as explained, this curve may be drawn with sufficient accuracy, and the area A' of the equilibrium polygon can then be measured by any of the usual methods.

If A be the given area whose moment of inertia is required, and if $H = \frac{1}{2} A$, the moment of inertia about an axis passing through the centre of gravity is:

$$I = AA',$$

and about a parallel axis is:

$$I' = A (A' + A''),$$

in which A'' is the area of the triangle $Ga'd'$, as shown in Art. 46 *b*. Since the moments of inertia thus obtained are the products of an area by an area, both usually in square inches, the result is given in inches⁴.

If the method of intercepts be employed as in Art. 46 *a*, the force-scale of pounds to the linear inch, used originally in con-

structing the force polygon $abcd$ will be replaced by an area-scale of square inches to the linear inch, by which scale the distances ab, bc , etc., are laid out. The first-moment scale will then be, as before :

$$\text{linear scale} \times \text{pole-distance } H;$$

but H , measured from the polygon Oad , will be given in square inches. The second-moment scale will be, as before, the product of the first-moment scale by the pole-distance H' , the latter being measured by the linear scale. The second-moment scale will then give the number of inches⁴ corresponding with the actual length in linear inches of the intercepts $a''b''$, etc.

(*b*) *Accurate determination.* Both of the methods of Art. 46 are applicable, with entire accuracy, to the determination of the moment of inertia of an area, when the latter can be divided into sections, the area of each of which, and its moment of inertia with respect to an axis passing through its centre of gravity, are known. In this case, the force representing the area of the section is applied, not at the centre of gravity of the latter, but at a distance from the axis of inertia which is equal to the radius of gyration of the area of the section about that axis. Thus, let a be the area of the section, k its radius of gyration about the axis Mm passing through the centre of gravity, k_1 its radius of gyration about the given axis of inertia $M'm'$, and L the distance between the two axes. Then, by Art. 45 *b*:

$$\begin{aligned} I &= ak^2; \quad k^2 = I/a; \\ I' &= I + aL^2 = ak_1^2; \\ k_1^2 &= I/a + L^2 = k^2 + L^2. \end{aligned}$$

The required radius of gyration k_1 is therefore the hypotenuse of a right-angled triangle whose sides are k and L , the magnitudes of which are known. The force corresponding with the sectional area a is then assumed to act at a distance k_1 from the axis of inertia and to be parallel to that axis. If the total area can thus be divided into geometrical figures to which this

principle can be applied, either the method of intercepts or that of the area of the equilibrium polygon can be used, with entire accuracy, for the determination of the moment of inertia of a plane area.

48. Higher Moment Surfaces: the n th Moment of an Area.

If an area be divided into very small parts or elements, and each of these elementary areas be multiplied by its distance from any given line or axis, the algebraic sum of these products is known as the *first moment*, or simply the moment (Art. 44) of the area about the given axis. Again, if each of the elementary areas be multiplied by the square of its distance from the given axis, the sum of the products thus obtained is called the *second moment*, or moment of inertia (Art. 47) of the area. In general, the n^{th} moment of the area about the given axis would be the sum of the products found by multiplying each elementary area by the n^{th} power of its distance from the axis.

Thus, Fig. 67, let it be required to find the successive moments of the area enclosed by the square $BEFG$ about an axis NA , passing through its centre of gravity and parallel to the side BG . Assume the area to be divided into elementary strips, as CD , parallel to the axis NA . Project C and D to E and F on the side EF , and connect the points E and F with the centre O of the axis NA , forming the triangle EOF .

The moment of any strip, as CD , about the axis NA varies as the distance of that strip from the axis. From the similar triangles OEF and OHL we have :

$$EF:HL :: AF:AD,$$

$$HL \times AF = EF \times AD = CD \times AD.$$

But AF is the moment-arm of EF (which is equal to CD), and AD is the moment-arm of HL . Therefore, the moment of CD about NA is equivalent to the moment of HL about NA , if HL be at the distance FA from NA .

Similarly, it may be shown that the moment of any elementary strip — similar to CD , but located in a different part of the area

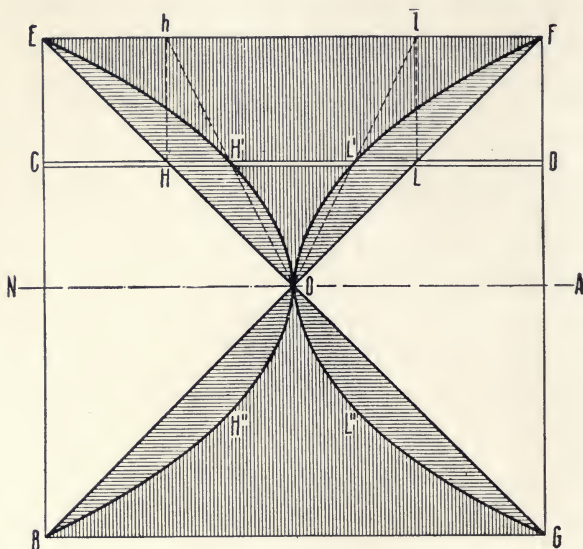

FIG. 67.

$NEFA$ — about the axis NA is equal to the moment about NA of that portion of the strip which is intercepted by the lines EO and FO , if that portion be at the distance FA from NA .

Hence, the product of the triangular area OEF by the distance AF of its most remote element EF from the axis NA is the first moment of the rectangular area $NEFA$ about the axis NA . Similarly, the first moment of the rectangular area $BNAG$ about the axis NA is equal to the product of the area of the triangle BOG by the distance AG , but, as this triangle is below the axis NA , the moment will be negative. The algebraic sum of the moments obtained from the triangles OEF and OBG is the moment of the square $BEFG$ about the axis NA , and is equal to zero, since the axis passes through the centre of gravity of the square. The areas OEF and OBG are known as the first-moment areas.

The second moment is the moment of the first moment. Hence, to obtain the second-moment area, the first-moment area is treated as if it were a simple area and its first moment found. Thus, let the triangle OEF be divided into elementary strips, as III . Project H and L to h and l , respectively, on the most remote element EF ; draw Oh and Ol , and the points H' and L' , where these lines intersect the element HL , will be points in the boundary of the second-moment area. Proceeding thus, we obtain the second-moment areas $OH'EFL'$ and $OH''BGL''$, whose sum, multiplied by the square of AF , the distance of EF or BG from NA , gives the second moment, or moment of inertia, of the square $BEFG$ about the axis NA .

For the third moment, the second-moment area is treated as a simple area, and its first moment is found. The operation is then repeated until the n th moment is determined.

49. Twisting Moment ; Polar Moment of Inertia. (a) *Twisting moment.* If a shaft be subjected, as by a crank, to a force of magnitude P applied normally to a radius of the cross-section at a distance p from the centre, the product Pp is called the twisting moment. The tendency of this moment is to twist the shaft around its axis and hence to shear it in a direction transverse to the axis. In works on mechanics of materials, it is shown that the twisting moment is equal to the product of the unit shearing stress, at a unit's distance from the axis, by the polar moment of inertia, *i.e.* :

$$Pp = S_s J/c,$$

in which c is the distance of the most remote fibre of the cross-section of the shaft from the centre of gravity of that cross-section, S_s is the unit shearing stress at the distance c , and J is the polar moment of inertia.

(b) *The polar moment of inertia, I_p (or J)* of a body or a plane surface is the moment of inertia of the body, or the area of the surface, when revolved about an axis which is perpendicular

to the plane of rotation of the body or the area. For plane figures, this axis of inertia or *pole* is perpendicular to the plane of the figure. For a shaft, it is perpendicular to the plane of the transverse section and coincides with the axis of the shaft.

There is a definite relation between the polar moment of inertia

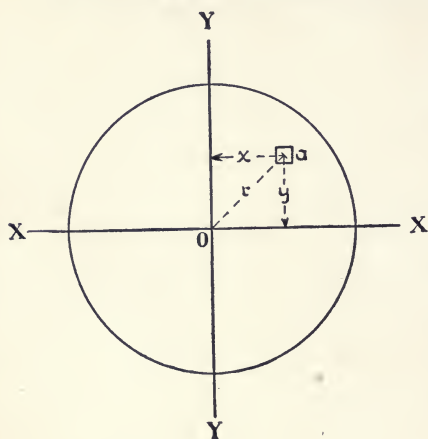

FIG. 68.

and the rectangular moments of inertia which have been discussed. Thus, let Fig. 68 represent a plane circular area with coplanar axes XX and YY , and let a be an element of the area which is distant r from the centre O , through which centre the pole passes in a direction perpendicular to the plane of the area. Let I_x and I_y be the rectangular

moments of inertia of the element a about the axes XX and YY , respectively. Then, if y and x be the distances of a from the axes XX and YY , respectively :

$$r^2 = x^2 + y^2,$$

$$ar^2 = ax^2 + ay^2,$$

$$I_p = I_x + I_y,$$

since ay^2 and ax^2 are the rectangular moments of inertia of the element a about the axes XX and YY , respectively, and ar^2 is the polar moment of inertia of a about the point O . This principle applies to every element and hence to the entire area. In general :

The polar moment of a plane area about any given point in its plane is the sum of the rectangular moments of inertia of the area about any two coplanar axes which pass through the given point and are at right angles to each other.

50. **Twisting and Bending Moments Combined.** A crank shaft is subjected to torsional stress between the crank and the point where the power is delivered. Similarly, a shaft carrying a driving and a driven pulley is under torsional stress between the two pulleys. Furthermore, the weights of the shaft, crank, and pulleys and the tension of the belts produce bending moments in the shafts.

In practical computations, these twisting and bending moments may be combined to form either a twisting moment equivalent to both of the original moments of torsion and bending, or similarly an equivalent bending moment. Rankine,* in combining the greatest direct stress due to the bending load and the greatest shearing stress due to the moment of torsion in a shaft, gives the intensity of the greatest resultant stress in the form:

$$t = \frac{1}{2} S + \frac{1}{2} \sqrt{S^2 + 4S_s^2}, \quad \dots \quad (1)$$

in which S is the maximum flexural unit-stress and S_s is the greatest shearing unit-stress due to torsion.

Let M_b be the bending moment, M_t the twisting moment, and EM_b and EM_t the equivalent bending and twisting moments, respectively, each assumed to be equivalent in effect to both M_b and M_t . By the fundamental formulæ for pure bending and pure torsion:

$$S = M_b c / I \text{ and } S_s = M_t c / J,$$

in which c is as defined in Art. 49.

For circular sections of diameter d :

$$I = \pi d^4 / 64 \text{ and } J = \pi d^4 / 32,$$

hence:

$$J = 2 I$$

For the equivalent bending moment, $t = EM_b c / I$. Substituting in (1):

$$EM_b = 1/2 (M_b + \sqrt{M_b^2 + M_t^2}). \quad \dots \quad (2)$$

For the equivalent twisting moment, $t = EM_t c / 2 I$. Substituting in (1):

$$EM_t = M_b + \sqrt{M_b^2 + M_t^2}. \quad \dots \quad (3)$$

* "Applied Mechanics," London, 1869, p. 358.

From (2) and (3): $EM_b = 1/2 EM_t,$ (4)

i.e., in converting a twisting moment into an equivalent bending moment the latter, on the same scale, is equal to one-half the twisting moment.

Grashof deduces equation (1) in the form:

$$t = \frac{m - 1}{2m} + \frac{m + 1}{2m} \sqrt{S^2 + 4 S_s^2},$$
 (5)

in which the value of m is usually taken as 4. Using that value, we have by the method as above:

$$EM_b = \frac{3}{8} M_b + \frac{5}{8} \sqrt{M_b^2 + M_t^2}$$

which is the form used by Reuleaux in *The Constructor*. Under these conditions, the equivalent bending moment is equal to five-eighths of the twisting moment.

It should be observed, as to the equivalent twisting moment (3), as deduced from (1), that the greatest resultant stress t , as given by Rankine, is not a shearing, but a direct stress. Merri-man,* in discussing combined flexure and torsion, finds the resultant maximum tensile or compressive unit-stress t as in (1), but deduces the greatest resultant shearing unit stress as:

$$s = \pm \frac{1}{2} \sqrt{S^2 + 4 S_s^2}$$
 (6)

from which, by the preceding methods:

$$EM_t = \sqrt{M_b^2 + M_t^2}.$$
 (7)

From (2) and (6):

$$EM_b = \frac{1}{2} \left(1 + \frac{M_b}{\sqrt{M_b^2 + M_t^2}} \right) EM_t$$
 (8)

The equations given above apply in their present form only to bodies of circular cross-section, as a shaft. They are applicable to those of other sections under similar stresses, when the proper values of c , I , and J are employed.

* "Mechanics of Materials," New York, 1909, p. 266.

The graphic method for combining bending and torsional stresses is shown in Fig. 69, as applied to a counter-shaft sup-

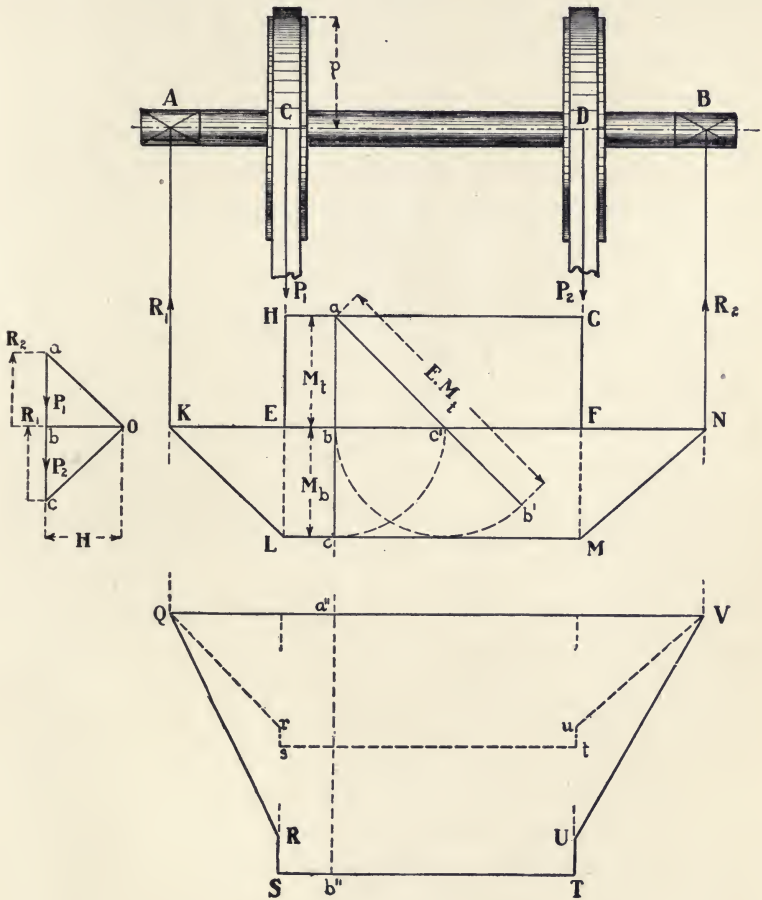

FIG. 69.

ported in bearings at *A* and *B*, and carrying a driving and a driven pulley at *C* and *D*, respectively. Such a shaft is subjected to bending stresses due to its weight, that of the pulleys and belts, and the tension of the latter. For simplicity, neglect the weight of the shaft and consider the loads P_1 and P_2 , due to

the weight of the pulleys and the pull of the belts, as acting in the same vertical plane. Draw the force polygon abc with pole O , and the corresponding equilibrium polygon $KLMN$. By Art. 41 the bending moment M_b at any section of the shaft, as b , is directly proportional to the corresponding ordinate, as bc , of the equilibrium polygon.

The shaft is also under torsional stress in the section CD between the driving and the driven pulleys. If p be the radius of the former pulley and P be the force exerted by the belt, the twisting moment M_t throughout the section CD will be Pp . Compute the bending-moment scale by Art. 36, and on the same scale construct the twisting-moment diagram $EFGH$, any ordinate of which is equal to M_t .

Using equation (3) to find the equivalent twisting moment, draw any ordinate, as abc , to the combined diagrams. With the centre b , revolve bc to bc' , and with the centre c' , revolve $c'b$ to $c'b'$ on ac' produced. Then, $ab' = ac' + c'b'$ is the equivalent twisting moment for the section b of the shaft, since $ab = M_b$, $bc = M_b$, $ac' = \sqrt{M_b^2 + M_t^2}$, and $c'b' = M_b$. Lay off $a''b'' = ab'$ in the lower diagram in line with ac , thus determining the points a'' and b'' . In a similar way all other points are found and the diagram $QRSTUW$, representing the equivalent twisting moment, is drawn. In the sections KL and FN , $M_t = 0$, and by (3), $EM_b = 2 M_b$. Since by (4), $EM_b = \frac{1}{2} EM_t$, the diagram $QrstuV$ for the equivalent bending moment is constructed by making each of its ordinates equal to one-half the length of the corresponding ordinate in the equivalent twisting-moment diagram.

PROBLEMS

60. A force of 12 pounds acts at right angles to the extremity of the diagonal of a square whose side is 10 inches. Find the moment of the force about the centre of the square.

61. Find the moment of a force of 15 pounds, exerted by a man upon the steering wheel of an automobile, about the axis of the wheel, the effective diameter of which is 18 inches.

62. In Fig. 55, assuming the forces P_1, P_2, P_3, P_4 to be to each other as 3 : 4 : 5 : 6, find the moments of the several forces about the point R .

63. Using the forces as given in Fig. 56, find the moments of the several forces about any point midway between the lines of direction of the forces P_3 and P_4 .

64. A brakeman sets up a brake on a car by pulling 40 pounds with one hand and pushing 40 pounds with the other. If his forces act tangentially to the brake wheel of 20 inches effective diameter, find the moment of the couple.

65. If the forces P_1, P_2, P_3 , and P_4 , in Fig. 58, be 200, 400, 600, and 800 pounds respectively, find the bending moment at M in the section of the beam cut by the line MNQ .

66. A straight rod AE , 8 feet long, weight neglected, divided in the points B, C, D so that $AB:BC:CD:DE::1:3:5:7$, supports weights of $P, 2P, 3P, 4P$ at the points B, C, D, E , respectively, and is in turn supported at G , the centre of gravity of the system of weights. Find the bending moment at a point M in the section midway between G and the point of application of the nearest force.

67. In Fig. 60, if θ be 45° and P equals one-half W , find the combined bending moments of P and W , the length of AB being taken as 12 feet.

68. Find the maximum moment of a force of 100 pounds acting upon the rim of a wheel, effective diameter 5 feet, about the axis of the wheel.

69. Find the moment of the area of the T-section, given in Fig. 63, about the line AL .

70. Find the moment of inertia of a triangular area about one side as an axis.

71. Compare the moment of inertia of a square about one side as an axis and that about one of its diagonals as an axis.

72. Find, by the method given in Art. 48, the second moment of a triangular area about an axis coinciding with one side of the triangle.

73. Find the third moment of a square area about an axis lying outside the square but parallel to one of its sides.

CHAPTER VI

THE FUNDAMENTAL THEORY OF BEAMS

THE determination of the character and magnitude of the internal stresses produced in the comprehensive class of bodies known as *beams* by the application of external loads or forces, presents a wide variety of problems which are capable of solution by graphic methods. For simplicity in the discussion of the latter, a brief review of the fundamental theory of beams is given below.*

51. Definitions. A beam may be generally defined as a rigid bar set, as a rule, horizontally, and supported at one or more points. If it has but two supports, one at each end, it is called a *simple beam*. If it be supported only in the middle or the portion considered be that projecting beyond a support, it is known as a *cantilever beam*. A *continuous beam* is a bar having more than two supports. The definitions, as above, refer only to the cases in which the beam rests freely on its supports. On the other hand, a beam is said to be *fixed* or *restrained* at a support, when, at that support, it is so constrained that the tangent to the elastic curve is horizontal there, as in the case of the built-in cantilever, Figs. 72 and 76. A beam having two supports may thus be simply supported as a simple beam, or one end may be supported and the other fixed, or both ends may be fixed.

When a beam is deflected by its own weight and that of the loads upon it, its neutral axis (Art. 61) bends in a curve known as the *elastic curve* (Art. 63). It is evident that the amount of the deflection thus produced is comparatively small and varies with different materials. The deflection may be due to either *uniform* or *concentrated loads*, or to the two combined.

*The notation and general methods of this chapter are those employed in Merriman's "Mechanics of Materials."

A beam is said to carry a uniform load when the latter is uniformly distributed over the beam and when the weight of the latter forms a part of this uniform load. Such loads are usually stated in pounds per lineal foot of the beam, the latter having the same cross-section throughout its length. Thus, let w be the weight of the uniform load per unit of length; then, for x units, the weight will be wx , and, for a span l units in length, wl or W would represent the total uniform load. A concentrated load P is one which is applied at one point only of the beam.

The external forces acting on a body and tending to change its shape are opposed by internal forces known as *stresses*; the stress thus produced may be *tensile*, tending to stretch or rupture the body; *compressive*, acting to cause failure by crushing; or *shearing*, in which the tendency is to sever the body by transverse cutting. The *unit stress* is the amount of the stress per unit of area of cross-section. The effect of any stress is a change in the form of the body; the amount of the change thus produced primarily by an external force or forces is called the *deformation*. Thus, a body under tension is elongated and one under compression is shortened, while shearing tends to produce detrusion or thrusting outward of the particles; as familiar examples, a rope used to hoist a weight is lengthened, a column supporting a load is compressed and shortened.

52. Fundamental Laws of Tension and Compression. These laws are:

(a) For small stresses, the materials used in engineering constructions may be considered as perfectly elastic, *i.e.*, they will regain their original form on the cessation of the stress.

(b) The deformations produced by small stresses are nearly proportional to the forces which cause them and also nearly proportional to the length of the body.

(c) When the stress is sufficiently great, the body fails to

return to its original form after the removal of stress, and a part of the deformation remains as 'permanent set.'

(d) Under a still greater stress, the deformation no longer increases in proportion to the stress, but grows more rapidly, and the body is finally ruptured.

53. Elasticity. The property, which most materials possess, whereby they tend to regain their original form after the removal of stress is known as *elasticity*.

If the stress to which a body is subjected be gradually increased, that point in the magnitude of the stress beyond which the body is incapable, after a removal of stress, of a return to its original form is called the *elastic limit*. Theoretically, this limit occurs at a definite point, but experimentally it is considered as at that point where the 'set' becomes well marked, as the stresses are increased, and after sufficient time has been given for the body to regain its original form.

The *Modulus of Elasticity*, also known as the *Coefficient of Elasticity* and designated by E , is the ratio of the unit stress in a material to the corresponding unit deformation. As the deformation within the elastic limit varies directly as the stress, it is clear that, for the same material, E is constant, as is shown very approximately by experiment.

54. Reactions at the Supports. When a beam, under the action of applied loads, is in equilibrium, it is evident that at the points of support there must be upward reactions equal to the downward pressures exerted at those points by the loads and the weight of the beam. To determine these reactions, the weight of the beam and the magnitudes and location of the loads must be known. Since the loads and reactions represent, in general, a system of vertical forces, the magnitudes of the reactions may be found by applying one or both of the following laws:

$$(a) \Sigma \text{ all vertical forces} = 0;$$

$$(b) \text{ moments of all forces} = 0.$$

In the case of the cantilever, a beam with but one support, it is evident from the first law that the reaction must be equal to the sum of the weights of the beam and the loads.

When the beam has two supports, it is necessary to apply the second law in order to determine the reactions. In this case, the centre of moments may be taken most conveniently at one of the supports.

Thus, let Fig. 70 represent a simple beam of 12 feet span with a concentrated load P , 5 feet from the left support. Designating the reactions at the left and right supports by R_1 and R_2 , respectively, and taking moments, first about the right, and then about the left support, we have, by the second law :

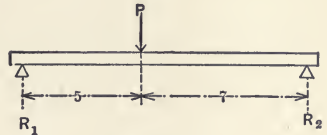

FIG. 70.

$$12 R_1 - 7 P = 0;$$

$$12 R_2 - 5 P = 0;$$

$$R_1 = \frac{7}{12} P;$$

$$R_2 = \frac{5}{12} P.$$

Again, let Fig. 71 represent a simple beam, 12 feet long, weighing 20 pounds per linear foot, and having concentrated loads of 300, 200, and 400 pounds applied, respectively, at 3, 5, and 8 feet from the left support. The weight of the beam may be considered as a concentrated load applied at the middle. Taking moments about the left support :

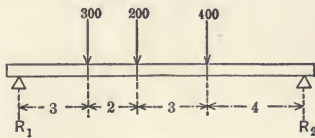

FIG. 71.

$$12 R_2 = 240 \times 6 + 300 \times 3 + 200 \times 5 + 400 \times 8.$$

Taking moments about the right support :

$$12 R_1 = 240 \times 6 + 300 \times 9 + 200 \times 7 + 400 \times 4.$$

Hence, $R_1 = 595$ pounds and $R_2 = 545$ pounds, the sum of

which is 1140 pounds, or the weight of the beam and its loads.

With a simple beam uniformly loaded, the reaction at each support is equal to half the weight of the beam, plus half the load. With a continuous beam, *i.e.*, one having more than two supports, the magnitude of the reactions cannot be determined by the application of laws (a) and (b), but must be found by the use of the properties of the elastic curve (Art. 63), as deduced for the given material and conditions of loading.

55. The Vertical Shear. A beam may fail by shearing in a vertical section. In Fig. 72, representing a cantilever, take any section, as *ab*,

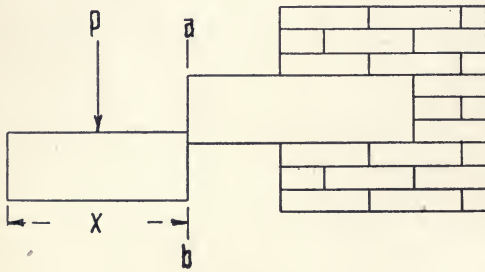

FIG. 72.

any section, as *ab*, distant *x* units from the left extremity. If *w* be the weight per unit of length of the beam and *P* be the concentrated load at the left of the section considered, it is evident that a force equal to

$P + wx$ acts downward on the left of the section *ab*, and that an equal force acts upward at the right of that section.

Again, in the simple beam, Fig. 73, take any section, as *ab*,

distant *x* units from the left support. In this case, there is a force $R_1 - (P + wx)$ acting upward on the left of the section and an equal force acting downward on the right of the section.

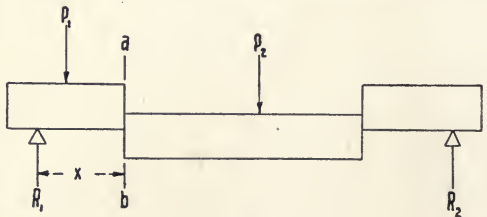

FIG. 73.

We have thus forces equal in magnitude but oppo-

site in direction acting on the two sides of the section. It is customary to call upward forces, positive, and downward forces, negative.

From the foregoing, it will be seen that :

the vertical shear V ,

at any vertical section of any beam, loaded in any manner, is the algebraic sum of all of the vertical forces on the left of the section ; or $V =$ reaction on the left of the section considered, minus all loads to the left of that section.

From this definition it is apparent that V may be positive or negative, according as the left reaction is greater or less than the sum of the loads to the left of the section. The direction in which the portion of the beam on the left of the section tends to move with respect to the portion on the right, is shown by the character of V . If V be positive, the left-hand portion is pressed upward ; if negative, downward.

Expressed in terms of R_1 , P , and w , the general equation for the vertical shear becomes :

$$V = \Sigma R_1 - \Sigma P - wx,$$

in which x is the distance in units between the left extremity of the beam and the section considered and ΣR_1 and ΣP are the sums of the reactions and loads, respectively, on the left of that section.

As numerical examples : in Fig. 72, let the beam be 12 feet long and weighing 20 pounds per linear foot, P be 150 pounds, and x , 6 feet. For the section ab , the left reaction is zero, and therefore, $V = 0 - 150 - 120$ or $V = - 270$ pounds, being thus negative. Again, in Fig. 73, let the beam be 12 feet long and weighing 20 pounds per linear foot, P to be 180 pounds applied at one foot from R_1 , and x to be 2 feet. Then, $V = 285 - 180 - 40$, or $V = 65$ pounds. From the positions of the load P and the weight of the beam, it will be seen that, for all sections between the left support and a point five and one-quarter feet to right of it, the vertical shear will

be positive; for sections beyond this point, the shear would be negative.

56. Shear Diagrams. The general equation for the vertical shear, as given above, makes it possible to draw a shear diagram for any section of a simple or cantilever beam, when the position and magnitudes of the loads and the weight of the beams are known.

Thus, Fig. 74, consider a simple beam l feet long and weighing

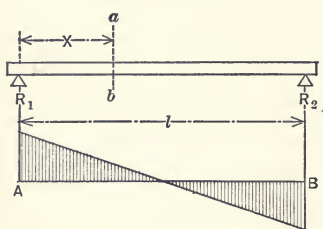

FIG. 74.

ing w pounds per linear foot. As the load is uniform, each reaction is $\frac{1}{2}wl$. Taking any section distant x from the left support, and remembering that $\Sigma R_1 = \frac{wl}{2}$ and

$$\Sigma P = 0, \text{ we have } V = \frac{wl}{2} - wx,$$

which shows that V has its maximum value when x is a minimum, *i.e.*, V is greatest and equal to $\frac{wl}{2}$ at the support, and

also that V is zero when $x = \frac{wl}{2}$. As this equation is of the

first degree in the variables V and x , the locus or curve represented by it will be a straight line; if the values of x be taken as abscissæ, those of V will be ordinates. If the base line AB be drawn and at A , taken as the origin of coördinates, an ordinate be erected equal to $\frac{wl}{2}$ on the scale employed, and from

the upper extremity of this ordinate a line be drawn, passing through the mid-point of AB and prolonged until it intersects the ordinate let fall from B , the area included between this line and the base line will be the diagram of shears for this case. The length of any ordinate in this diagram, measured in terms of the first ordinate, will give the vertical shear at the section of the beam directly above the ordinate. Ordinates above

the base line indicate positive shear; those below it, negative shear.

Thus, Fig. 74, let the span be 12 feet and the weight of beam per linear foot, 20 pounds. Each reaction, $\frac{wl}{2}$, will be 120 pounds. Taking any convenient scale and assigning to x consecutive values from zero to 12 and erecting the corresponding ordinates, the shear diagram is drawn as in the figure. The shear at the left end is + 120; at the right end, - 120; and at the middle, is zero.

Again, Fig. 75, take a simple beam with concentrated loads

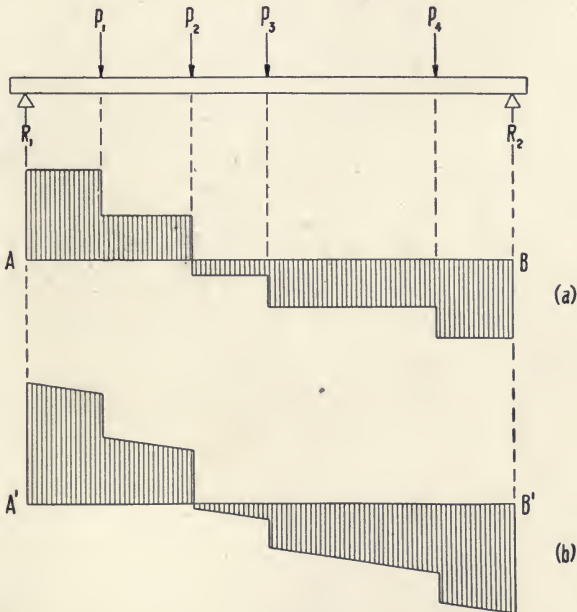

FIG. 75.

$P_1 \dots P_4$, and as in (a), neglect the weight of the beam. Draw the base line AB , and at its left extremity erect an ordinate equal to R_1 , whose value can be found by methods previously given. From the upper end of this ordinate, draw a line parallel

to the base line and meeting the ordinate corresponding to the sections of the beam where the load P_1 is applied; then drop a distance equal to this load, measured in terms of R_1 , and again draw a line, parallel to the base line and meeting the ordinate corresponding with the next load; continue this process until the diagram is complete, as shown in figure.

If, as in (b), the weight of the beam had been considered, the shear diagram would differ from that of (a) in that the reactions would have greater values, and that succeeding ordinates between the left support and the first load, and between consecutive loads, would decrease uniformly in value above the base line and increase below that line. This action is indicated also by the general equation for vertical shear.

For example, let the beam, Fig. 75, be 12 feet span, having loads of 300, 600, 400, and 500 pounds applied at 2, 4, 6, and 9 feet, respectively, from the left support. R_1 will then be 825 pounds and R_2 975 pounds. Then $V = 825 - \Sigma P$. In (a), the shear for any section between the left support and the first load will be + 825 pounds; between the first and second loads, + 525 pounds; between the second and third, - 75 pounds; between the third and fourth, - 475 pounds; and, between the fourth load and the right support, - 975 pounds.

Taking the weight of the beam as 20 pounds per linear foot,

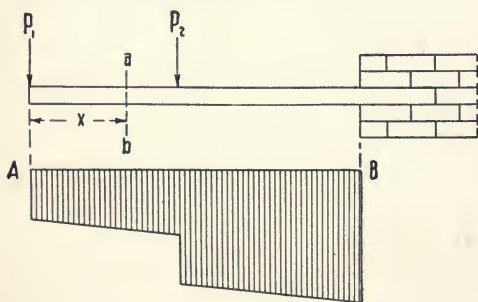

FIG. 76.

we have, as in (b), $R_1 = + 945$ pounds, and then, between the left support and the first load of 300 pounds, a gradual decrease in the ordinates, so that, just to the left of that load, V is + 905 pounds, and just to the right of

it, is 605 pounds. Continuing this process, the shear just to the

left of the right support will be found to be -1095 pounds. The inclined lines, bounding the top and bottom of the shear diagram, are parallel.

Let Fig. 76 represent a cantilever beam with its left extremity free, the right fixed, and carrying the concentrated loads P_1 and P_2 , in addition to its own weight. The diagram may be drawn as before, using the general equation, $V = \Sigma R - \Sigma P - wx$, and bearing in mind that ΣR , for any section ab , to the left of the fixed end, is zero, *i.e.*, that there is no left reaction. It should be noted that the ordinates in this diagram are all negative, since the shear at any section is obtained by subtracting a positive quantity from zero. Had the left end of the beam been fixed and the right end free, the value of ΣR , or the left reaction, would have been equal to the weight of the beam plus the loads, and the shears would all have been positive, as shown in Fig. 77.

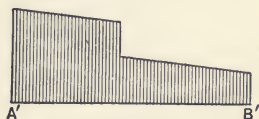

FIG. 77.

As a numerical example, let the beam, Fig. 76, be 8 feet long, weigh 20 pounds per linear foot, and have loads P_1 of 100 pounds at the free end and P_2 of 200 pounds at the middle. As $R_1 = 0$, $V = 0 - \Sigma P - wx$, and giving to x various values, the vertical shear is found to be, at the free end, -100 pounds; just to the left of the middle section, -180 pounds; at the right of that section, -380 pounds; and, at the wall, -460 pounds.

57. The Bending Moment. In order to determine the stresses in a beam, it is necessary to find the bending moment (Art. 41), as well as the shearing force, at any section of the beam. A beam fails generally by transverse rupture. Thus, in Fig. 76, the force P_1 and the weight of the portion of the beam to the left of the section ab tend to produce rotation of that part of the beam about any point in the section, while the effect of

P_2 , of the weight of the portion of the beam to the right of ab , and of the reaction at the support is to produce rotation in an opposite direction of that part of the beam, about the same point in the section ab . The measure of the tendency to rotation would be, in either case, the moment of the resultant of the forces considered above, with reference to the point in the section.

Since the beam is in equilibrium, the moment of the resultant of the forces to the right of a section, as ab , must be equal to that of the resultant of the forces to the left. Hence :

the *bending moment* M at any section of a beam is the algebraic sum of the moments of all the external forces acting on the portion of the beam to the left of the section, with reference to a point in that section; or, $M =$ moment of reaction, minus the moment of loads.

The bending moment is positive or negative, according as the portion of the beam to the left of the section considered, tends to rotate in a clockwise or contra-clockwise direction.

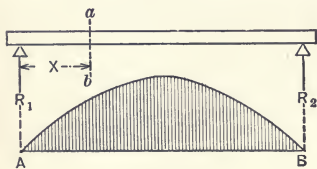

FIG. 78.

Let Fig. 78 represent a beam of length l , carrying a uniformly distributed load weighing w pounds per unit of length. Each reaction is then $\frac{wl}{2}$. For any section distant x units from the left support, the bending moment is :

$$M = \frac{wlx}{2} - \frac{wx^2}{2},$$

in which expression $M = 0$ when $x = 0$ and also when $x = l$. Hence, the bending moment is zero at the supports. Again,

M is a maximum and equal to $\frac{wl^2}{8}$ when $x = \frac{l}{2}$. From the form of the equation, it will be seen that the curve of bending moments is a parabola. The diagram of bending moments is laid out by drawing a base line AB , giving x various values, and plotting, as ordinates, to any convenient scale, the values of M obtained from the equation. Any ordinate therefore expresses, on the scale adopted, the value of the bending moment for the corresponding section of the beam.

Thus, in Fig. 78, let $l = 12$ feet, and $w = 50$ pounds. Substituting in the equation for M , we find that, when $x = 0$ and when $x = 12$, $M = 0$; when $x = 6$, $M = 900$ pound-feet; when $x = 3$ feet or 9 feet, $M = 675$ pound-feet. Any other values may be found similarly.

Again, Fig. 79, consider a simple beam carrying the concentrated loads P_1, P_2, P_3 ; neglect the weight of the beam. In this case, the general equation for the bending moment at any section distant x units from the left support is:

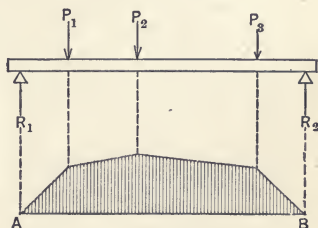

FIG. 79.

$$M = R_1x - \Sigma P(x - p),$$

in which R_1 is the left reaction, P is any concentrated load to the left of the section considered, and p is the distance of that load from the left support. Thus, for any section between the left support and the load P_1 , $M = R_1x$; and, for any section between P_1 and P_2 , $M = R_1x - P_1(x - p_1)$, in which p_1 is the distance of P_1 from the left support. As before, $M = 0$ when $x = 0$ and when $x = l$. As the expression for M for each of the several loads is the equation of

a straight line, the curve of bending moments becomes a broken line, as shown in the figure.

Considering the weight of the beam, the general equation for the bending moment becomes:

$$M = R_1x - \frac{wx^2}{2} - \sum P(x-p),$$

from which it will be seen that the portion of the moment curve between the left support and the first load, or between any two consecutive loads, is parabolic in form. For a simple beam, all the bending moments are positive.

For example, in Fig. 79, let the beam be of 12 feet span and the loads P_1 , P_2 , and P_3 be 50, 30, and 70 pounds, respectively, acting at 3, 6, and 9 feet from the left support. R_1 will then be 80 pounds. At the supports, M is zero; under P_1 , it is 240 pound-feet; under P_2 , 330; and under P_3 , 330 pound-feet.

The bending moments of a cantilever beam will be positive or negative, as the support is at the left or right end of the beam.

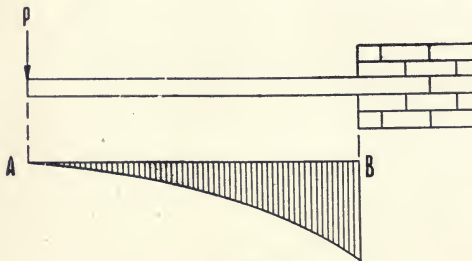

FIG. 80.

Fig. 80 shows a beam of the latter type. The bending moment at a section x units from the left is:

$$M = -\frac{wx^2}{2} - Px.$$

58. Relation between Bending Moment and Vertical Shear.

The bending moment at any section of a beam is equal to the area of the diagram for vertical shears included between the section and the left support, the area being measured in terms of the load and linear scales employed.

For example, let Fig. 81 represent a simple beam carrying the concentrated loads $P_1 \dots P_4$. Construct the shear diagram on

the base line AB . For any section distant x units from the left support, the bending moment is:

$$M = R_1x - P_1x_1 = P_2x_2,$$

in which x_1 and x_2 are the distances of P_1 and P_2 , respectively, from the section considered. The expression R_1x is the area of the rectangle whose altitude is $Aa = R_1$, measured in load units, and whose base is x , measured in length units; P_1x_1 and

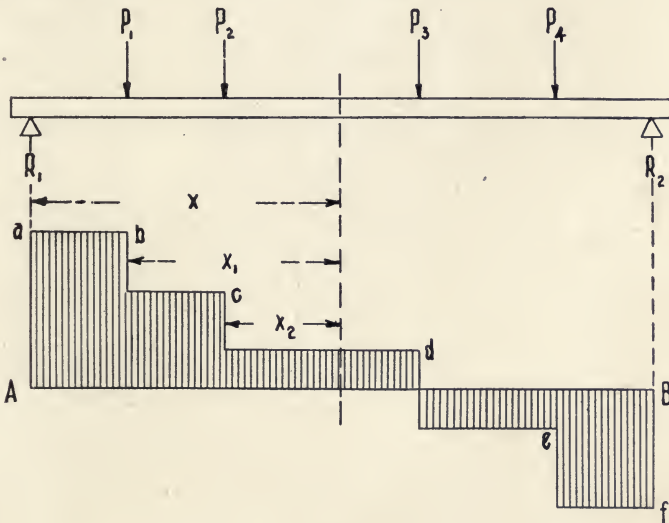

FIG. 81.

P_2x_2 are the areas, respectively, of the similar rectangles having P_1 and P_2 as their altitudes and x_1 and x_2 as their bases. The sum of the areas of the two latter rectangles, deducted from the first rectangle R_1x , leaves the area of the shear diagram to the left of the section considered, as stated above, this area being measured in terms of the load and length units employed and being equivalent to M . The principle is established, therefore, for a system of concentrated loads.

It is evident that this principle holds also for a uniformly loaded beam, since, in this case, the loads P_1, P_2, P_3 , etc.,

would be equal and their distance apart would be infinitesimal; the broken line *abcdef*, Fig. 81, would then be replaced by a straight line, as in Fig. 74.

59. Maximum Bending Moment. Since the bending moment at any section is equal to the area of the portion of the shear diagram extending from the left support to the section, it is evident that M will be a maximum when this partial area is a maximum, *i.e.*, at that section beyond which the area of the shear diagram ceases to increase with an increase in the value of x . Such a section occurs in Fig. 81 when the broken line *abcdef* crosses the base-line AB . Hence, the bending moment is a maximum when the vertical shear is zero.

60. Internal Stresses and External Forces. When a beam, loaded in any manner, is in equilibrium, internal stresses are

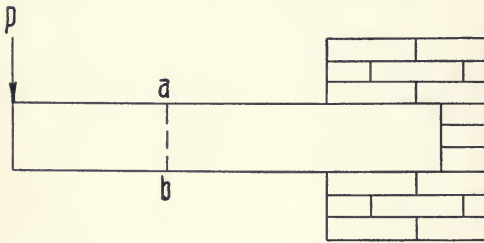

FIG. 82.

produced within it which oppose the external forces and aid in maintaining equilibrium. In any given case, there must be a definite relation between these stresses and forces. Thus, con-

sider the cantilever, Fig. 82, having the load P acting at the free end. At any section, as ab , the tendency of the force P and of the weight of the portion of the beam to the left of the section, is to produce rotation about ab and to shear at that section. This tendency is opposed, and the beam to the left of the section is kept in equilibrium, by the resisting and counterbalancing stresses set up at the section ab . Assume a plane to be passed through the section ab , as in Fig. 83, dividing the beam into two parts, and let forces, X , Y , and Z , equal in magnitude to, and of

like direction as, the stresses, be applied to the severed parts. It is evident that the equilibrium of each portion of the beam will still be maintained.

Hence :

the external forces on each side of any cross-section of any beam are held in equilibrium by the internal stresses at that section.

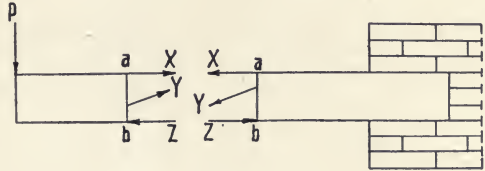

FIG. 83.

Since the system of forces is in equilibrium, the following condition of statics must obtain for the forces :

$$\begin{aligned}\Sigma \text{ all horizontal components} &= 0, \\ \Sigma \text{ all vertical components} &= 0, \\ \Sigma \text{ moments of all forces} &= 0.\end{aligned}$$

The external forces will produce at the cross-section stresses of different character—tensile, compressive, and shearing. These stresses may all, however, be resolved into horizontal and vertical components. It follows, from the first condition, that some of the horizontal components must act in one direction and some in another, *i.e.*, that some must be tensile and some compressive, and that the sum of the former must be equal to that of the latter.

Similarly, from the second condition, the sum of the vertical components must be equal to the algebraic sum of the vertical forces to the left of the section, which sum has already been expressed by V , equal in magnitude but opposite in direction. The algebraic sum of the internal vertical stresses is called the *resisting shear*; the relation between it and the vertical shear is:

$$\text{Resisting Shear} = \text{Vertical Shear.}$$

From the third condition, it follows that the algebraic sum of the moments of the external forces about any point in the section considered, *i.e.*, the bending moment, must be equal to the

algebraic sum of the moments of the internal horizontal stresses about the same point, the latter sum being known as the *resisting moment*. Hence:

$$\text{Resisting Moment} = \text{Bending Moment.}$$

The principles established in this investigation apply to any beam, loaded in any manner.

61. Neutral Surface and Neutral Axis. The fundamental laws cited in the preceding article are of primary importance in the investigation of the stresses in beams; the study of these stresses will be aided materially by a further investigation of the properties of the *neutral surface* and the *neutral axis* of beams under applied loads.

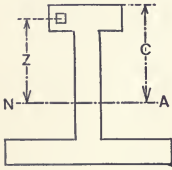

FIG. 24.

If a simple beam be loaded, it will undergo more or less 'deflection,' *i.e.*, the upper side will become concave and the lower side convex. The upper fibres of the beam are thus subjected, in being shortened, to horizontal compressive stresses, while the fibres of the lower portion are elongated by tension. From the upper surface of the beam the stress in the fibres passes through gradually decreasing compression, and then changes to tension which stress gradually increases and is greatest at the lower surface of the beam. Hence, in every vertical element of the vertical section of a beam, there must be a point where the fibres are under neither compression nor tension, and the stress is zero. The locus of these points is a surface called the *neutral surface*; the intersection of this surface with the plane of the vertical cross-section is known as the *neutral axis*. The amount of elongation or compression of any fibre is directly proportional to its distance from the neutral axis.

The neutral surface passes through the centre of gravity of the cross-section. Thus, let Fig. 84 represent the cross-section of an I beam, the line NA the neutral axis, and z the distance of any fibre from that axis. If S be the unit stress on the horizontal fibre at the greatest distance c from the neutral surface, then the stress on any fibre at unit distance from that surface will be equal to $\frac{S}{c}$, and at any distance z , the unit stress will be $S\frac{z}{c}$.

For any elementary area a , at the distance z , the horizontal stress will be $Sa\frac{z}{c}$, and, for the entire section, the total horizontal stress will be $\Sigma Sa\frac{z}{c}$. But:

$$\Sigma Sa\frac{z}{c} = \frac{S}{c} \Sigma az = \Sigma \text{ all horizontal stresses.}$$

In the preceding article, it was shown that the algebraic sum of all horizontal stresses was zero. Therefore, $\frac{S}{c} \Sigma az = 0$. As $\frac{S}{c}$ must have a definite value, Σaz must equal zero. From the definition of the centre of gravity of an area (Art. 28), it is known that this condition exists only when the line of reference passes through the centre of gravity, through which point therefore the neutral surface must pass.

62. Shearing Force and Bending Moment. In determining the strength of a given beam, it is necessary to ascertain the maximum shearing force and bending moment which may occur in any beam at any point. The following relations have been shown to exist for any section of any beam, loaded in any manner:

Resisting Shear = Vertical Shear;

Resisting Moment = Bending Moment.

If A denote the area of any vertical cross-section and S_s be the unit shearing stress, then, by definition :

$$\text{Resisting Shear} = AS_s.$$

Calling V the vertical shear for the same section, we have, since the vertical shear equals the resisting moment :

$$AS_s = V, \text{ or } S_s = \frac{V}{A}.$$

Thus, the section of the beam being known and also the positions and magnitudes of the loads, the maximum shearing force may be readily determined.

Again, that the beam may be in equilibrium, the bending moment at the given section must be counterbalanced by the moment of the internal horizontal stresses about a point in the section. Letting S represent the horizontal unit stress, whether tensile or compressive, upon the fibre most remote from the neutral axis and at a distance c from that axis, and letting z be the distance of any elementary area a from the axis, as in Fig. 84, it follows that :

$$\frac{S}{c} = \text{unit stress at distance unity,}$$

$$S \frac{z}{c} = \text{unit stress at distance } z,$$

$$aS \frac{z}{c} = \text{stress on elementary area } a.$$

To obtain the resisting moment for all the internal horizontal stresses, with respect to the neutral axis, the stress on each elementary area must be multiplied by the distance of that area from the neutral axis ; or :

$$\text{Resisting Moment of horizontal stresses} = \frac{S}{c} \Sigma az^2.$$

But, the expression, Σaz^2 is the moment of inertia of the section with respect to its neutral axis and may be represented

by I . Substituting this and remembering that the resisting moment is equal to the bending moment M :

$$\frac{SI}{c} = M, \text{ or } S = \frac{Mc}{I},$$

from which the maximum tensile or compressive stress may be found when the cross-section of the beam and the positions and magnitudes of its loads are given.

The expression $\frac{I}{c}$, known as the *modulus of the section* or the *section factor*, is thus the quotient of the moment of inertia of the section divided by the distance of its most remote fibre from its neutral axis. The determination of the moments of inertia of various sections has been treated in Art. 47; the value of c may be found when the position of the centre of gravity (Arts. 28, 30, 44) of the section has been determined.

63. The Elastic Curve. When a beam is deflected by applied loads, the curve assumed by its neutral axis is known as the *elastic curve*. The

equation of this curve will now be deduced.

From the assumption that the fibres above or below the neutral surface of any beam are elongated or contracted by an amount proportional to their distance from the

neutral surface, it follows that any vertical line, drawn upon the side of a beam before the latter is deflected, will still be a straight line after the beam becomes curved.

Let Fig. 85 represent a short portion of a beam under flexure, in which na is the curve assumed by the neutral axis, and mm'

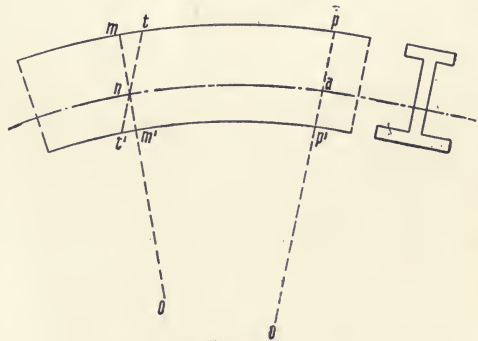

FIG. 85.

and pp' are two normal sections passing through n and a and meeting, when produced, in o , the centre of curvature. Through n , pass tt' parallel to pp' . As mm' and pp' were parallel before the beam was deflected, it is evident that pt has been elongated by an amount equal to mt , and that $p't'$ has been shortened by the amount $m't'$, the elongation and shortening being proportional to the distances of the fibres concerned from the neutral surface.

From the similar triangles pom and mnt , we have

$$om : nm :: mp : mt,$$

and, replacing om by its equivalent R , the radius of curvature, nm by c , the distance of the most remote fibre from the neutral surface, mp by dl , an indefinitely small part of l , the length of the beam, and mt by λ , the amount of elongation dl , the proportion becomes :

$$R : c :: dl : \lambda. \dots \dots \dots (a)$$

Assuming that the elongation λ is produced by the unit stress S (from the principle that the unit elongation bears the same ratio to the unit length as the unit stress to the coefficient of elasticity E), it follows that :

$$\lambda = \frac{Sdl}{E} \dots \dots \dots (b)$$

Substituting this value of λ in equation (a), we have :

$$R = E \frac{c}{S} \dots \dots \dots (c)$$

But, from Art. 62, $\frac{c}{S} = \frac{I}{M}$. Therefore :

$$R = \frac{EI}{M}, \dots \dots \dots (d)$$

an equation giving the radius of curvature of any section of the beam in terms of the bending moment and moment of inertia of the section and of the coefficient of elasticity of the material.

By the aid of the calculus, it may be shown that the radius of curvature for any point (x, y) of a curve of length l is:

$$R = \frac{dl^3}{dx \cdot d^2y} \dots \dots \dots (e)$$

Substituting this value of R in equation (d),

$$\frac{dl^3}{dx \cdot d^2y} = \frac{EI}{M}, \dots \dots \dots (f)$$

a general differential equation of the elastic curve.

In investigating the stresses in beams, the axis of abscissas is taken as parallel to the neutral axis of the beam before flexure and the axis of ordinates as perpendicular to the neutral axis. It will be seen, therefore, that dl is virtually the same as dx , the projection of dl upon the axis of X . Replacing dl in equation (f) by dx and simplifying, we have:

$$\frac{dx^2}{d^2y} = \frac{EI}{M} \text{ or } M = EI \frac{d^2y}{dx^2} \dots \dots \dots (g)$$

As a beam is considered to be homogeneous throughout its length and also of the same cross-section, E and I are constants for all parts of the curve, M being the only variable.

By inspection of equation (g), it will be seen that the character of M depends upon $\frac{d^2y}{dx^2}$, the second differential coefficient of the equation of the curve, as both E and I are always positive. Again, as EI in equation (d) equals MR , it will be seen that M and R are simultaneously positive or negative, *i.e.*, when M is positive, the upper side of the beam is concave or under compression, and R is directed upward and positive; and that, when M is negative, the lower side of the beam is concave and under compression, and R is directed downward and is negative as is the case in Fig. 85.

As an application of the general formula (g), consider a simple

beam, as in Fig. 86, having a load P at the middle. R_1 is $\frac{1}{2}P$ and the bending moment at any section between P and the left support is :

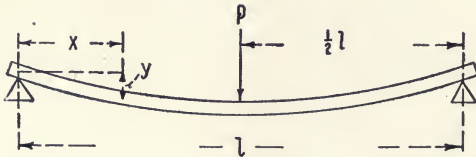

FIG. 86

$$EI \frac{d^2y}{dx^2} = M = \frac{1}{2} Px.$$

Integrating once, we have :

$$EI \frac{dy}{dx} = \frac{1}{4} Px^2 + C.$$

Now, $\frac{dy}{dx}$, *i.e.*, the slope of the curve, is zero directly under P , where $x = \frac{1}{2}l$. Therefore, $C = -\frac{1}{16}Pl^2$, and substituting this value, the equation becomes :

$$EI \frac{dy}{dx} = \frac{1}{4} Px^2 - \frac{1}{16} Pl^2.$$

Integrating again and finding the value of the constant from the fact that $y = 0$ when $x = 0$, the equation of the elastic curve for the portion of the beam to the left of P becomes :

$$48 EIy = P(4x^3 - 3l^2x).$$

The deflection of the beam at any section is the value of y for that section, which value may be obtained by substituting the value of x for that section in the equation, and solving for y . Thus, the deflection for a section midway between the left support and the load is found by making $x = \frac{1}{4}l$ in the equation and obtaining the corresponding value of y , which value is equal to $-\frac{11 Pl^3}{768 EI}$, but the minus sign is neglected since the value of y

is measured downward from the axis of abscissas, as shown in the figure.

The maximum deflection, represented by Δ , will be at the middle and is equal to $\frac{Pl^3}{48 EI}$.

CHAPTER VII

FUNDAMENTAL THEORY OF BEAMS (*CONTINUED*)

64. Relation of Curves of Load, Shear, and Bending Moment.*

A definite relation exists between the curves representing the loads, vertical shear, and bending moments for any given beam. Thus if, for a simple beam, a *load-curve* be drawn representing the amount of the load per running foot, and a derived curve be constructed from this by graphic summation, the ordinates of the latter curve will show the total load on the left of any section. If then, from the area between the derived curve and the base-line, the area representing the left reaction be deducted, the ordinate at any section will then give the vertical shear to the left of that section. The shear curve is thus the summation of the load-curve, less the area corresponding with the left reaction. Similarly, as shown in Art. 58, the ordinate or intercept at any point in the bending-moment diagram is equal to the summation of the portion of the shear diagram included between that point and the beginning of the diagram at the left support. The principles, as above, are general. Hence, the load, shear, and moment curves form a continuous series, in which each is the integral of the one preceding it.

65. Relation of Curves of Bending Moment, Slope, and Deflection. Similar relations exist between the curves of bending moment, slope, and deflection. The *deflection* (Art. 63) of a beam at any section is the value, for that section, of the ordinate y of the elastic curve, or the curve in which the neutral surface of the beam is bent by the applied loads; the *deflection*

* For further discussion, with examples, of the subjects of Arts. 64 and 65, the student is referred to Lineham's "Mechanical Engineering," Goodman's "Mechanics Applied to Engineering," and Cotterill's "Applied Mechanics."

curve is the elastic curve plotted, for convenience in measurement, to a greater vertical scale, the horizontal scale being the same or greater; the *slope* at any point is, in general, the angle which the tangent to the elastic curve makes with the horizontal, or with the neutral axis of the unstrained beam; the amount of the slope between any two points of the elastic curve is equal to the angle between their respective tangents to the curve; the ordinates to the *slope curve* give the slope of the elastic curve at all points.

Figure 87 represents a cantilever of uniform section throughout, whose neutral axis is bent from its original position OX into the curve OX' by applied loads. Let l_m be the distance from the free end to the centre of gravity of a portion m, n of the beam, the point m being indefinitely close to O and m and n being very near together, so that the radius of curvature R may be taken as the same for both points.

From m and n , draw the tangents mX and na to the elastic curve. Then, as a tangent is normal to its radius, the angle θ between the radii of curvature to m and n is equal to the angle between the two tangents, and also, by definition, to the amount of the slope between m and n .

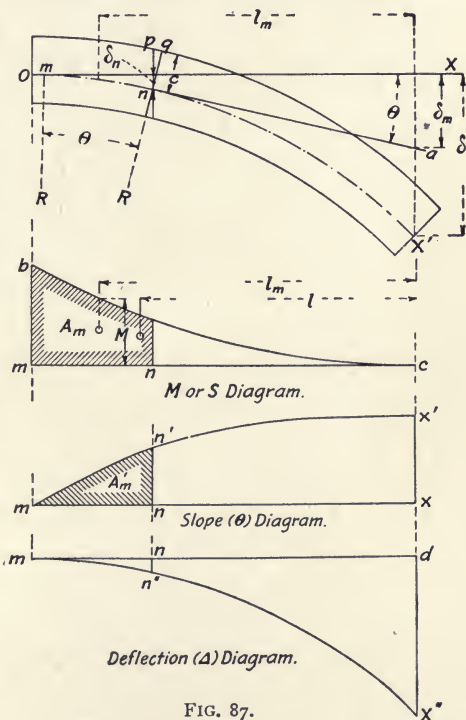

FIG. 87.

Bending Moment and Deflection. As the angle θ is very small and is taken in circular measure, $\tan \theta = \theta$, and :

$$\theta = \text{slope between } m \text{ and } n = mn/R.$$

But, from Art. 63 *d*, $R = EI/M$, in which M is the mean bending moment between m and n . Therefore :

$$\theta = \frac{M \times mn}{EI}.$$

In the bending-moment diagram bmc , the area $A_m = M \times mn$ is the portion of the diagram corresponding with the part mn of the beam. Hence :

$$\theta = \frac{A_m}{EI}.$$

Let δ be the total deflection of the beam at the free end, and δ_m the portion of this deflection which is due to the bending moment between the points m and n . Then, as θ is very small :

$$\tan \theta = \theta = \frac{\delta_m}{l_m};$$

$$\delta_m = \theta \times l_m = \frac{A_m \times l_m}{EI}, \dots \dots \dots (a)$$

and, since the total deflection is the sum of the deflections due to all such portions as mn :

$$\delta = \frac{A \times l}{EI}, \dots \dots \dots (b)$$

in which A is the total area of the bending-moment diagram to the section where δ occurs, and l is the distance of the centre of gravity of that area from the free end of the beam. Hence, to find the value of the deflection at any section of the beam, divide by EI the moment, about the free end, of the corresponding portion of the bending-moment diagram.

Bending Moment and Slope. By Art. 62, $M = SI/c$ and $I/c = Z$, in which S is the stress in the most remote fibre at the distance c from the axis, and Z is the modulus of the section. Hence :

and let mdX'' be the deflection (elastic) curve, whose ordinate mn'' corresponds with the point n in the beam. Then :

$$\begin{aligned} \tan \theta &= \theta = \delta_n / mn, \\ \delta_n &= mn'' = mn \times \theta, \\ &= mn \times \text{average slope between } m \text{ and } n, \\ &= \text{length of portion of beam} \times \text{its average slope,} \\ &= \text{partial area } A_m' \text{ of slope curve, } (d) \end{aligned}$$

a relation which holds for all portions of the beam and for their sum. The deflection curve mdX'' can therefore be drawn by taking for its ordinates the summation of the slope-curve area. This curve is in Fig. 87 identical with the elastic curve, OX' .

Summary. For the portion mn and the point n in the beam, we have :

$$\begin{aligned} \text{ordinate of stress curve, } S &= \text{ordinate of } M \text{ curve} \times I/Z; \\ \text{ordinate of slope curve, } \theta &= mn' = A_m \times I/E \\ &= \text{sum } S \text{ curve} \times I/E; \\ \text{ordinate of deflection curve, } \Delta &= mn'' = A_m' = \text{sum } \theta \text{ curve.} \end{aligned}$$

These relations hold for all portions of the beam and for their sum. It will be seen that the load, shear, moment, slope, and deflection curves form a continuous series, each being the summation of the one preceding it.

66. Stress Curves. The ordinates of the stress curve give, for any point of the beam, the value of the stress S (Art. 61) in the most remote fibre at the distance c from the neutral axis. As shown in Art. 65, the ordinates of the stress curve are derived from those of the bending-moment curve by dividing the latter ordinates by $I/c = Z$, the modulus of the section. When, as in Fig. 87, the section is assumed to be uniform throughout, the value of Z will be constant, and therefore the M curve may be used as an S curve, if due regard be had to the scale. When, however, the beam is not of uniform section, Z will vary with each change, and a separate stress curve must be plotted.

67. Deflection Curves for Simple Beams. The formulæ of

Art. 65 were deduced for cantilever beams. The same methods are applicable to simple beams. Thus, if the cantilever, Fig. 87, be inverted, it will represent a portion of a simple beam from one support at X' to the section at O , where the tangent to the elastic curve is horizontal. Hence, the deflection at any point between X' and O can be found from formula (*b*), Art. 65 :

$$\delta = \frac{A \times l}{EI},$$

where A is the area of the bending-moment diagram from the section of horizontal tangency at O to the given section and l is the distance of the centre of gravity of that area from the support X' . For the remaining portion of the beam, from O to the other support opposite X' , the process is the same, except that the moment of the area is taken about the other support.

68. Graphic Method of Constructing the Deflection Curve. Equation (*b*), Art. 65, for ascertaining the deflection at any given point in a beam, is cumbrous in application, since the area of a part or all of the bending-moment diagram must be found, and then the centre of gravity of that area must be located. The methods used for these two operations are necessarily approximate, although a close approach to accuracy may be attained for the first by employing graphic summation. A further objection to this equation is that its results apply to one point only, and to locate the point having a given deflection, maximum or otherwise, requires several trial solutions.

The whole of the deflection curve can be drawn at one operation by applying the method of the force and equilibrium polygon. The use of this method is warranted by the consideration that the ordinates of the bending-moment diagram and those of the deflection diagram are both proportional to moments — the former to the moments of forces, the latter to those of partial areas. Hence, the same general principles apply to both diagrams. Each ordinate of the deflection curve is the moment of

a moment (Art. 46), and, therefore, the curve may be constructed, like the M curve, as an equilibrium polygon, if we treat as forces the partial bending-moment areas to which the ordinates are directly proportional, as equation (b), Art. 65, shows.

Let Fig. 88 represent a simple beam AB , carrying three concentrated loads. Draw the force polygon Oab , with pole-distance H , and the bending-moment diagram CDE (Art. 41).

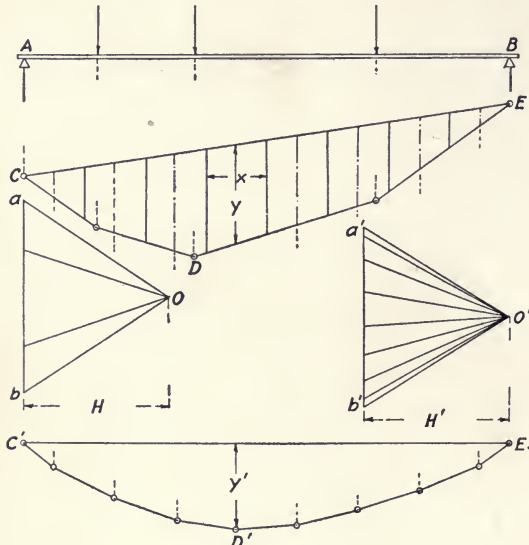

FIG. 88.

Divide this diagram into any number of vertical strips of uniform width x , and draw the middle ordinate of each strip. The area of the latter is then, approximately, the length of the middle ordinate, as y , multiplied by the constant width x . The series of areas into which the diagram is thus divided is the new system of parallel and vertical forces for which the deflection diagram is the equilibrium polygon; each of these forces is assumed to act on the centre-line of its strip.

With any convenient scale, draw the new force polygon $O'a'b'$, with pole-distance H' , and the corresponding equilibrium polygon $C'D'E'$ for this system of forces. A curve drawn tangent to the sides of this polygon will be the deflection curve, and will represent the elastic curve of the beam to an exaggerated vertical scale. Hence, the actual deflection of

distance H , and the bending-moment diagram CDE (Art. 41). Divide this diagram into any number of vertical strips of uniform width x , and draw the middle ordinate of each strip. The area of the latter is then, approximately, the length of the middle ordinate, as y , multiplied by the constant width x . The series of areas into which the diagram is thus divided is the new system of parallel and vertical forces for which the deflection diagram is the equilibrium polygon; each of these forces is assumed to act on the centre-line of its strip.

the beam at any point will be equal to the length of its corresponding intercept, as y' , in the polygon $C'D'E'$, when measured on the proper scale and divided by EI , as required by equation (b), Art. 65.

The final scale for y' is evidently the product of two individual scales: the moment-scale for the polygon $C'D'E'$ and an area-scale representing the area, $x \times y$, in the polygon CDE . Let:

- l = linear scale, inches per inch, both diagrams;
- w = force scale, pounds per inch, diagram Oab ;
- H = pole-distance, inches, diagram Oab ;
- x = measured width of strip, diagram CDE ;
- y = measured length of intercept, diagram CDE .

Then (Art. 36):

- moment-scale, CDE diagram = $l \times w \times H$ = pound-inches;
- moment at intercept $y = M = y \times l w H$;
- moment-area, measured from diagram = $x \times y$;
- moment-area, actual = $x \times M = x y l^2 w H$.

Hence, the area-scale per inch of measured length of y is:

$$(x y l^2 w H) / y = x l^2 w H.$$

For the polygon $C'D'E'$:

- pole-distance, inches = H' ;
- measured length of intercept = y' ;
- moment-scale = $l \times H'$.

Hence, the final scale for the intercept y' is:

$$\text{area-scale} \times \text{moment-scale} = x l^3 w H H',$$

and the moment of the partial bending-moment area, $x \times y$, is:

$$y' \times x l^3 w H H'.$$

By Art. 65 *b*, the deflection at the point in the beam corresponding with y and y' is then:

$$\delta = \frac{y' (x l^3 w H H')}{EI}.$$

Let $EI = aH'$, *i.e.*, let a be any convenient ratio and make H' proportional to EI . Then, the formula becomes:

$$\delta = \frac{y'(xl^3wH)}{a}$$

δ is the deflection in inches; x and y' are distances in inches, as measured from the drawing; H and H' are similar measurements in inches from the drawing; the linear scale l applies to both diagrams and represents the number of inches of actual length per inch of measured length from the diagram; w is the number of pounds per inch of measured length of the force polygon Oab .

69. Deflection Curves for Overhanging and Restrained Beams.

Overhanging and restrained beams are similar in this, that, at one or more sections called *inflection points*, the stresses which have been tensile become compressive and *vice versa*, the bending moment is zero, and the curvature changes from convex to concave.

(a) *Overhanging Beams.* Figure 89 represents a beam AC overhanging the right support by the amount BC ; the bending-moment diagram is $adbca$. The curvature changes at the section D , the inflection point. It will be seen that the section of length l is in the condition of a simple beam, and that the sections of lengths l_1 and l_2 are in the condition of a cantilever. The reactions, shears, and moments can be computed from the methods of Arts. 54, 55, and 57, the reaction at the right support being considered as an upward force for sections to the right of that support. From Art. 63 *g*, the equation of the elastic curve between the supports may be found and the deflection for any

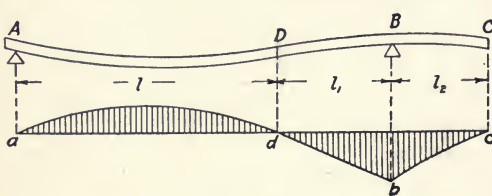

FIG. 89.

given point determined, or the methods of Art. 68 may be applied to the bending-moment diagram and the deflection curve for the three divisions of the beam be thus constructed graphically.

(b) *Restrained Beams.* Figure 90 represents a restrained beam which is built in at both supports. The inflection points

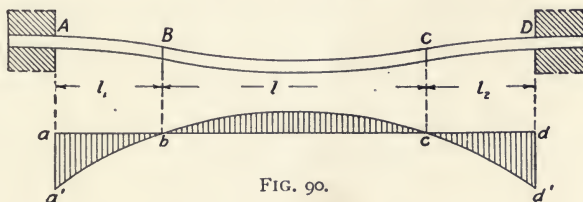

FIG. 90.

are located at B and C. Following the same general reasoning, the beam can be divided into a central simple beam of length l , and two cantilevers of lengths l_1 and l_2 . If, in Fig. 89, the length be such that the tangent to the elastic curve will be horizontal at the right support, the conditions would be the same as those for the beam in Fig. 90 at both supports. The general methods, cited previously, are applicable for the construction of the moment diagram in any particular case, and, from this diagram, the deflection diagram can be drawn by the methods of Art. 68, or the deflection can be computed for any section from the general equation of the elastic curve as modified for the conditions existing.

70. Stiffness. If two simple beams of the same length but of different cross-section carry the same loads applied in the same way, the maximum deflection of one beam will be less than that of the other, that is, it will be the stiffer of the two. Again, if the system of loading be the same in each case but the amounts of the loads be such that both beams will have the same deflection, the stiffer beam will carry the greater load. Under these conditions, the load is a measure of the relative stiffness. For cantilever and simple beams, in general :

$$W = mEI\Delta / l^3,$$

in which W is the load, l is the length of the beam, and m is a quantity whose value depends on the kind of the beam and the system of loading. From this equation, it will be seen that, as the stiffness is proportional to W , it is also proportional directly to E and I , and inversely to the cube of the length.

The load which a beam can carry is also a measure of its strength. For cantilever and simple beams, in general :

$$W = nSI/lc,$$

in which S is the stress in the outermost fibre at the distance c from the neutral axis and n is a quantity whose value depends on the kind of the beam and the system of loading. Hence, the strength of the beam is proportional directly to S and I and inversely to l and c .

There is thus a marked difference between stiffness and strength. A floor beam, for example, cannot be loaded to its full capacity without exceeding the maximum deflection which is permissible.

71. Influence Diagrams.* The shear and bending-moment diagrams which have been discussed (Arts. 56, 57) represent the magnitudes of the shears or moments at *all points* in the beam for *stationary loads*, uniform or concentrated. When a load moves across a beam, its effect on the reactions at the supports and on the moment, shear, and stress at any given point in the span varies with each change in its position, and the *influence line* or *influence diagram* is used in graphic statics to show the variation in these functions at any given point in a beam, or, in the case of a bridge truss, in any member of the latter, as the load traverses the beam or truss. The influence diagram, therefore, shows the effects, at a *fixed point*, of a *moving load* or system of loads, while the shear and moment diagrams represent,

*The student will find a full discussion of the use of influence lines, as applied to stresses in truss members, in three papers contributed by Myron S. Falk to the *School of Mines Quarterly*, Vol. XXIV.

for stationary loads, the same functions for all points in the beam.

With bridge trusses, the maximum moments, shears, and stresses in the members are the important elements in design, and the chief value of the influence line lies in the fact that, through its use, the corresponding positions of the moving load can be readily determined for any given member. The influence diagram is usually drawn for the unit-load, expressed in pounds, tons, or kilograms, and its ordinates are then multiplied by the number of pounds, etc., in the given load, to obtain the corresponding moment, shear, or stress.

72. Influence Diagram for Bending Moments due to a Single Moving Load. Figure 91 represents a simple beam of length L ,

whose section at C is distant l and l_1 from the left and right supports, respectively. It is required to find the bending moment at C for every position of a moving load of W pounds which crosses the beam from right to left.

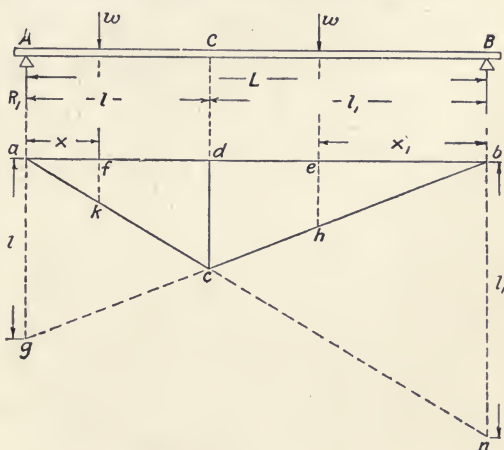

FIG. 91.

Let $w =$ unit-load = one pound, and assume w to be on the section l_1 at the point e , a distance x_1 from the right support. Taking moments about the latter, the left reaction (Art. 54) is :

$$R_1 = wx_1/L,$$

and the bending moment (Art. 57) at C is the moment of this reaction about C , or:

$$M_1 = wx_1l/L = x_1l/L \dots \dots \dots (a)$$

since $w = 1$.

Now, assume w to be on the section l at the point f , a distance x from the left support. The left reaction will then be:

$$R_1 = w(L - x)/L,$$

and the bending moment at C will be the difference between the moments of R_1 and w about C , or:

$$M = wx(L - l)/L = xl_1/L \dots \dots \dots (b)$$

since $w = 1$.

From its form, (a) is seen to be the equation of a straight line, inclined to the horizontal by an angle whose tangent is l/L . Further, if $x_1 = 0$, $M_1 = 0$, and this line passes through the point b , corresponding with the right support. From a , let fall the line $ag = l$ and draw bg . Then, the bending moment at C , for any value of x_1 , will be represented by the corresponding ordinate, as eh , of the partial diagram bdc , for:

$$l : L :: eh : x_1.$$

$$\therefore eh = x_1l/L = M_1.$$

In a similar way, it can be shown that equation (b) represents the line an passing through the point a and making an angle with the horizontal whose tangent is l_1/L . Hence, $bn = l_1$. As before, the ordinate fk represents the bending moment at C when the load w is at f , and, for any position of the load between C and A , the moment will be shown by the corresponding ordinate of the partial diagram adc . The lines an and bg must cut the vertical dc at the same point c , since w is, in both cases, then at C . This may be shown also by making x and x_1 equal to l and l_1 , respectively, in (a) and (b), when:

$$M = M_1 = ll_1/L = dc.$$

The triangle abc and the line acb are, therefore, the influence diagram and the influence line, respectively, for the bending moments at the section C , due to the passage of the unit-load

w across the beam. The moment produced by the total load W is W times the corresponding ordinate for the unit-load.

73. Influence Diagram for Bending Moments due to a Uniform Moving Load. With uniform unit-loads spaced at unit length over the entire beam or truss, there is a unit-load at every point on the line ab . Hence, the moment at C , Fig. 91, is equal to the area of the triangle abc , or :

$$M = (ab \times cd)/2,$$

and, by Art. 57, the ordinate under the point C is a maximum when $l = l_1$, the value of the moment for the total load on the beam being then :

$$M = WL^2/8,$$

in which the total load $W = wL$, w being the load per linear foot.

When the uniform load covers a part only of the truss, its moment at C is evidently equal to the area of the partial diagram included between the ordinates at the beginning and end of the load, multiplied by the load per lineal foot.

74. Influence Diagram for Bending Moments due to a Series of Concentrated Loads. The bending moment at any section in

a beam carrying a series of loads is the sum of the several bending moments of the individual loads. The moment of each load may be found from the influence dia-

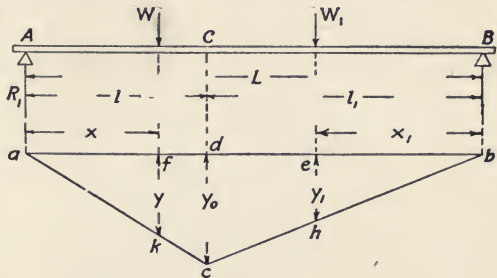

FIG. 92.

gram, Fig. 91, for the unit-load. In Fig. 92, let the beam AB carry a series of concentrated moving loads, like the wheel-loads of an engine and tender crossing a bridge. It is required to find the maximum moment at any section of the beam, as C .

As in Fig. 91, construct the diagram abc for a unit load, and let ΣW , at the distance x from the left support, and ΣW_1 , at the distance x_1 from the right support, represent, respectively, the summations of the concentrated loads to the left and right of C . The moment of each summation will then be equal to the aggregate moments of the individual loads composing it, since the summation represents the resultant load concentrated at the centre of gravity of the system.

The bending moment at C , due to a unit-load at f , is the ordinate y , and that of ΣW , in the same position, is hence $\Sigma(Wy)$; similarly, the moment of ΣW_1 is $\Sigma(W_1y_1)$. The moment of the series is then :

$$M = \Sigma(Wy) + \Sigma(W_1y_1). \dots \dots \dots (a)$$

By similar triangles (Fig. 91),

$$y = y_0 \cdot x/l \text{ and } y_1 = y_0 \cdot x_1/l_1.$$

Substituting in (a),

$$M = y_0 \left[\Sigma \left(\frac{Wx}{l} \right) + \Sigma \left(\frac{W_1x_1}{l_1} \right) \right].$$

If the series of loads move the distance dx toward A , x and x_1 become $x - dx$ and $x_1 + dx$, respectively. The corresponding difference in the moment is then :

$$dM = \Sigma \left(\frac{Wdx}{l} \right) - \Sigma \left(\frac{W_1dx}{l_1} \right). \dots \dots \dots (b)$$

For a maximum

$$\frac{dM}{dx} = \frac{\Sigma W}{l} - \frac{\Sigma W_1}{l_1} = 0,$$

and

$$\frac{\Sigma W}{l} = \frac{\Sigma W_1}{l_1} = \frac{\Sigma W_1}{L-l};$$

whence

$$\Sigma W = (\Sigma W + \Sigma W_1) \frac{l}{L}, \dots \dots \dots (c)$$

must be the origin of coördinates. From b , draw the horizontal line $bd = L$, and, from d , the vertical $da = \text{unity}$; connect a and b . Then, bc is the influence line for the shears at the section C , so long as the load is to the right of that section. Thus, for the ordinate gh , immediately below the load, we have, by similar triangles:

$$gh : 1 :: x : L$$

$$gh = x/L = V.$$

Therefore, the ordinate below the load and included in the partial diagram kcb gives the shear at C , for any position of the load between B and C .

As soon as the load W passes to the left of C , $V = R_1 - W$, the conditions being the same as before, except that there is a constant deduction, W , from the previous value of V , which deduction becomes unity for the unit-load diagram. Therefore, from c , let fall ce , and, from a , let fall ad , each equal to unity, and draw ed . By the same reasoning as before, it can be shown that, for any position of the load between C and A , the ordinate below the load and included in the partial diagram dke gives the shear at C for that position. The influence diagram for the unit-load and the section at C is then $dekcb$. The shears for the load W are obtained by multiplying the corresponding ordinates from the unit-load diagram by W .

76. Influence Diagram for Shears due to a Uniform Moving Load. When there is a uniform unit-load, spaced at unit distance,

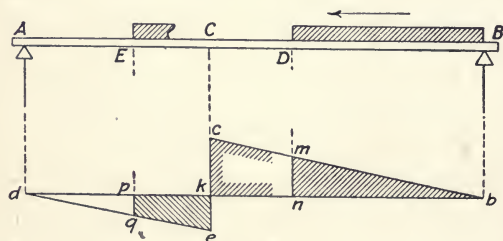

FIG. 94.

passing over the beam, the shear at any section, as C , Fig. 94, is equal to the algebraic sum of the positive and negative sections of the influence diagram

which lie below the load. Thus, when the head of the load

reaches the point D , the shear at C is positive and equal to the area of the triangle bmn ; when the load covers the section EB , the shear at C is equal to the area bck — area $ekpq$.

It will be seen that the maximum shear (positive) occurs when the load extends over the section between C and the right support; and that the maximum shear, numerically, exists when the load covers the greater section of the span, whether that section be CA or CB in the particular case considered. The minimum, or greatest negative shear, is produced when the load lies only on the section CA .

77. Influence Diagram for Shears due to a Series of Concentrated Loads. For a series of concentrated loads, the shear at any section of a beam, as C , Fig. 94, is the algebraic sum of the ordinates of the unit-load diagram which are below the loads, each ordinate being multiplied by its corresponding load. The maximum shear at a given section, when there are two or more loads on the beam, can thus be found by giving the system of loads different positions and comparing the algebraic summations for these positions. Usually, the number of possible positions for maximum shear is limited, and the operation is relatively simple.

The influence line for such a series of loads may also be found directly, without the aid of the unit-load diagram, by the method of the force and equilibrium polygon. Thus, Fig. 95 represents a simple beam AB of span L , over which passes, from right to left, a series of three loads, W_1 , W_2 , and W_3 , at fixed distances, a and b , apart. Let x and x_1 be the distances of W_3 and W_1 , respectively, from the right and left supports. For convenience in using the influence diagram, the intercept representing the magnitude of the left reaction R_1 should come under the leading load W_1 . Hence, in constructing the polygons, the beam AB is reversed, *i.e.*, swung through 180° on the right support as a pivot, as shown by $A'B'$ below. This change does not alter the relative order or magnitude of the loads and

reactions, and R_1 is still the left reaction of the original beam, although it is now assumed to act at the right-hand end of the reversed beam.

From the intersection, B' , of the line of action of W_1 with the horizontal line, $B'A' = L$, lay off to the right the distances $x, b,$

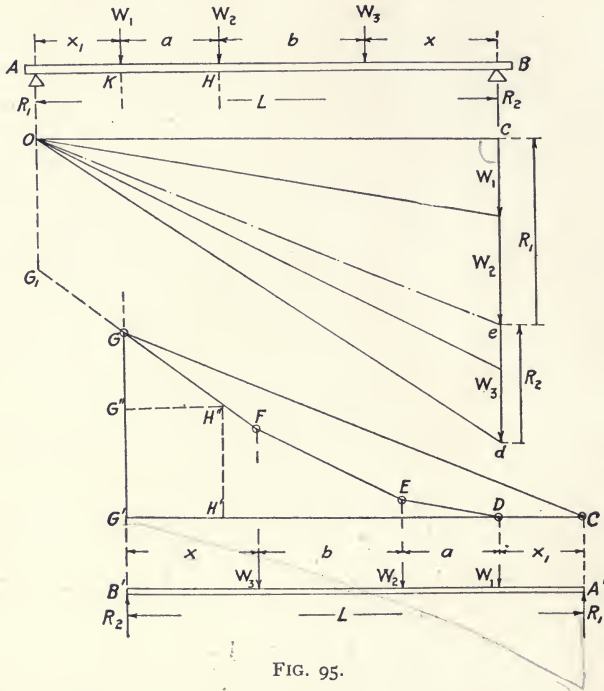

FIG. 95.

$a,$ and $x_1,$ in the order named, and draw the lines of action of the loads and reactions. On the load-line cd plot the loads from c downward, to any convenient scale; from c set off horizontally the pole-distance, $cO = L$; from O draw the rays to the extremities of the lines representing the loads; and construct the corresponding equilibrium polygon, $CDEFG$, with closing line GC . Draw the ray Oe parallel to GC . Then, $ec = R_1$ and $de = R_2$.

Prolong the first side CD of the equilibrium polygon to its

intersection at G' with the vertical from G . Then, the intercept GG' between the last side and this first side produced is equal to the left reaction for this position of the loads, since, when multiplied by the pole-distance L , the product represents, by Art. 41, the moment of R_1 about the right support of the beam, or :

$$\begin{aligned} GG' \times L &= R_1 \times L, \\ GG' &= R_1. \end{aligned}$$

This may also be shown by similar triangles. Thus, the triangles Oce and $CG'G$ are equal in all respects. Hence,

$$GG' = ce = R_1.$$

The form of the polygon $CDEFG$ and the value of the intercept GG' apply only to the position of the loads shown in the diagram. With any change in that position, the length of the intercept alters. Thus, if the distance x be increased or lessened by any amount, the new value of x is laid off in the lower diagram, and, from its left end, an ordinate is erected to intersect the side FG , produced if necessary. The intercept between this intersection and CG' , produced if necessary, is the value of R_1 for these conditions. In any case, R_1 is equal to the intercept under the leading load W_1 .

The partial polygon $DEFG$ can be modified to serve as an influence line for the shear V at any given section, as H , of the beam. Thus, project H to H'' on the polygon and to H' on the line CG' . Then, while the loads are approaching from the right, the shear at H will be equal to R_1 , and the magnitude of the latter, at any instant, is given by the intercept under W_1 . When W_1 reaches H , $R_1 = H'H''$, and the shear influence line to this point is $DEFH''$. After W_1 passes H , $V = R_1 - W_1$, a value which changes constantly as W_1 advances. When W_2 is at H , W_1 has reached K , and $R_1 = GG'$. From G , lay off $GG'' = W_1$. Then $G'G'' = R_1 - W_1$ is the shear at H for this position, and $DEFH''G''$ is the shear influence line for the sec-

tion at H , during the passage of the loads from the right support B to the section K of the beam. This method is applicable to any section and to any number of loads.

78. Influence Diagrams for the Left Reaction. (a) *Single Moving Load.* Figure 96 represents a simple beam AB of span

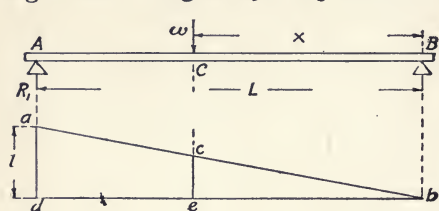

FIG. 96.

L over which a load of W pounds passes from right to left. It is required to construct the unit-load influence diagram, showing the changes in the value of the left reaction R_1 as

the load advances from the right support.

Let x be the distance of W from the right support at any instant. Then, $R_1 = Wx/L = x/L$ for the unit-load of one pound. This expression is the equation of a straight line making an angle with the horizontal whose tangent is $1/L$. When $x = 0$, $R_1 = 0$, and some point, as b , vertically below the right support, is the origin. From b , draw the horizontal line $bd = L$, and, from d , the vertical $da =$ unity. Connect a and b , and draw the ordinate ce under the load. Then, the tangent of the angle $abd = 1/L$ and ab is the required influence line, for the triangles abd and cbe are similar, and:

$$ce : ad :: x : L$$

$$ce = x/L = R_1.$$

The influence diagram is, therefore, the triangle abd , and, for any given position of the load, the corresponding value of R_1 will be the ordinate between ab and the base-line db . In all cases, the ordinate from the unit-load diagram must be multiplied by W to obtain the reaction due to the total load.

(b) *Uniform Load.* Let the section of length x , Fig. 96, be covered by a uniform unit-load, spaced at unit-distance. Then, when the head of the load is at any section, as C , the left reac-

tion will be equal to the area of the triangle cbe or $ce \times x/2 = x^2/2L$. The unit-load influence line and diagram are therefore ab and abd , respectively, as before.

(c) *Series of Loads.* If, in Fig. 95, the side FG be prolonged to its intersection at G_1 with the vertical from the left support, the line $DEFG_1$ will be, for the reasons given in Art. 77, the influence line for the left reaction, during the passage of the leading load of the series from the right to the left support. The intercept below this leading load and between the line $DEFG_1$ and the horizontal line CG' , produced if necessary, is the value of R_1 for that position of the series of loads.

CHAPTER VIII

FRAMED STRUCTURES: ROOF TRUSSES; BRACED CANTILEVERS

THE graphical analysis of the stresses in a jointed frame, subjected to the action of external forces, has been discussed in Art. 19. The principles of the method given therein are applicable to various framed structures, notably to the important class known as *trusses*, which, in the limited range of the stresses to which their principal members are subjected, resemble the jointed frame so closely as to permit the treatment of the truss virtually as such a frame in calculations for its design. The scope of this book does not admit detailed investigation of this extensive subject. The general principles of its more important branches, however, will be discussed briefly.

79. Assumptions in the Analysis of Framed Structures. The general assumptions made in the analysis of the jointed frame are applied also in the investigation of framed structures. They are :

(a) The external loads are held in equilibrium by the internal forces or stresses produced by these loads in the members of the structure.

(b) The loads, whether uniform or concentrated, are assumed to be divided proportionately and as acting only at the joints of the structure. Such division and application of the loads would produce only longitudinal tensile or compressive stresses in the members of the structure, and not the transverse stresses due to bending, as in a solid beam.

(c) The joints of the structure are assumed to permit rotation, as if the members were hinged. This is practically true of pin-

connections, although not of riveted or other more or less rigid joints.

(*d*) The axial lines of the members, passing through the centres of gravity of the cross-sections of the latter, are all assumed to lie in the same plane. This assumption is sufficiently accurate, so far as the stresses in the principal members are concerned. In the joints, however, bending stresses are produced in the connections, as for example, by eye bars which lie in parallel planes.

80. Definitions. Trusses, in general, consist of an upper chord, a lower chord, and the web members. The *upper chord* is the upper line — straight, broken, or forming an approximate curve — spanning the distance between the supports; the *lower chord* is the similar lower line of members; the *web members* connect the upper and lower chords, and may be either vertical, radial, or diagonal; the *span* is the distance from the centre of one support to that of the other, and hence between the extreme joints of the structure. A member subjected to tensile stress only is called a *tie*; one under compression only, a *strut*; one fitted for both stresses, a *tie-strut*. When a member, under a symmetrical dead load for example, is subjected to tension only, it may, under unsymmetrical loads, undergo a reversal of stress and be in compression. To limit its stress to tension only, a *counter-brace* can be fitted to receive the stress, which, while compressive on the main member, will be tensile on the counter. When the main member is acting to sustain the load, the counter-brace is unstrained, and *vice versa*. A *redundant member* is one which does not act directly to sustain the load, but may serve an auxiliary purpose, as in aiding another member to resist buckling. Counter-braces, when unstrained, are, strictly speaking, redundant. Redundant members are hence, in general, those which are not required to prevent distortion of the structure under the given system of loading, and in which, as

shown by the force polygon or stress diagram, no stresses exist. As contrasted with a structure containing redundant members, an *incomplete structure* is one the number of whose members is insufficient to prevent distortion of the structure under all forms of loading.

81. Notation. As shown in Fig. 97, the members divide the truss diagram, $A . . . M$, into sectional areas, each of the latter and the spaces outside of the chords being marked by a capital letter. In the stress diagram or force polygon, $a . . . m$, the same letters, but not in capitals, are placed at the corresponding vertices to designate the magnitude and direction of a load or stress whose line of action in the truss diagram is named by the letters on each side of it. Thus, CD and cd , in the truss and stress diagrams, respectively, designate the load at the peak; GH and gh , the stress in the left-hand web member; etc. In drawing the stress polygon for a joint, the members intersecting at the latter are taken in regular order, clockwise or the reverse, and, in this order, the sides of the polygon follow. Since the sequence of these sides must be known to determine the character of the stresses in the members, the order in which the latter are taken may be conveniently marked by a circle with arrow-heads, as in Fig 97. Thus, in the latter, the loads and stresses are taken in clockwise rotation; at the peak, the order is then: HC, CD, DK, KH ; and the corresponding stress polygon is $hcdkh$.

The character of the stresses in the members is, as in Art. 19, shown by their direction with regard to the two joints in the truss diagram between which each stress exists, a stress acting from these joints being tensile or *positive*, and one toward them, compressive or *negative*. The directions of the stresses are determined from the stress polygon for the joint in question, since, in traversing the perimeter of this polygon, the direction of the stresses is the same from the starting point to the return thereto.

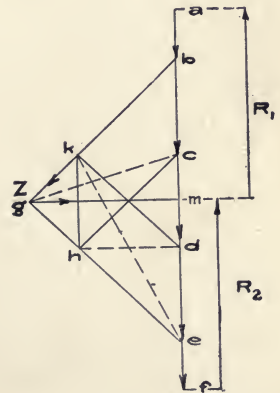
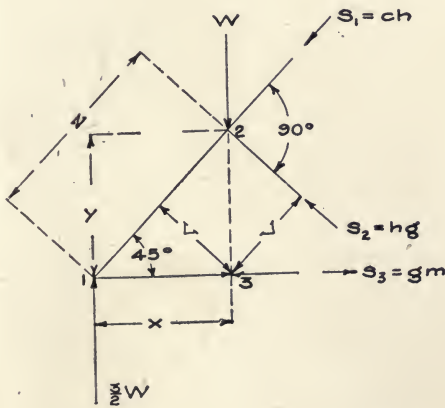
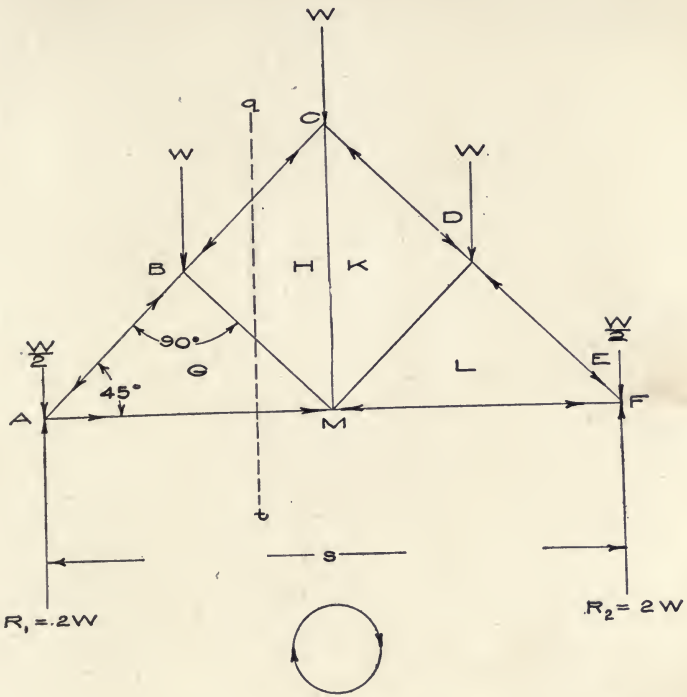

FIG. 97.

This follows, since the stresses and loads at any joint form a system of forces in equilibrium. Thus, at the peak, Fig. 97, the directions of the stresses are: $h-c$, $c-d$, $d-k$, and $k-h$; the stress $h-c$ acts upward toward the joint, and is hence a compressive stress; on the other hand, $k-h$ acts from the joint and is tensile. The character of the stresses in the members may be indicated in the truss diagram by arrow-heads or by using double or heavy lines for struts.

82. Methods of Determining Stresses. The stresses existing in the members of a framed structure may be determined by:

(a) *Reciprocal Diagrams.* Inspection of the truss diagram, Fig. 97, shows that the members intersect to form triangles and that each of these triangles is virtually an equilibrium polygon, since the loads at the joints are held in equilibrium by the stresses in the sides. Hence, for each triangle, a force polygon may be constructed (Art. 16), and these polygons, when combined, form the *stress diagram* for the entire truss. Each equilibrium polygon and its corresponding force polygon constitute *reciprocal diagrams*, whose property, as defined by Clerk Maxwell,* is:

“If forces represented in magnitude by the lines of a figure (*force polygon or stress diagram*) be made to act between the extremities of the corresponding lines of the reciprocal figure (*equilibrium polygon or truss diagram*), then the points (*joints*) of the reciprocal figure will all be in equilibrium under the action of these forces.”

Again, in either of the two diagrams, any point of intersection of the lines indicating loads or stresses may be considered broadly as a pole, parallel to whose rays a corresponding closed polygon exists in the other diagram. Thus, Fig. 97, the peak of the truss diagram is the intersection of the load CD and the stresses DK , KH , and HC ; in the stress diagram, these loads

* *Philosophical Magazine*, April, 1864.

and stresses are represented by the respectively parallel lines, cd , dk , kh , and hc , forming the closed polygon $cdkhc$. Similarly, in the stress diagram, the stresses bg , gh , and mg intersect at the point g , and these stresses are represented in the truss diagram by the closed polygon G . The two diagrams are therefore fundamentally reciprocal.

The principles governing the construction of the stress diagram are those discussed previously (Art. 20) with regard to the equilibrium and force polygons. The process is, however, reversed in this case, since the stress diagram is derived from the equilibrium polygon.

In general, the method to be followed is to draw first the force polygon for the loads; then, starting at a joint on the line of action of a load, preferably at the left support, construct the force or stress polygon for the load, the reaction, and the stresses acting at that joint, taking the loads and stresses usually in clockwise order. This polygon will determine the magnitude of a stress acting between the first joint and the next in clockwise order; this stress is then combined with the known load at the second joint, and, from their resultant and the other stresses acting at that joint, the second force polygon is constructed. In this way the magnitude of all the stresses is found, the essential condition being, as with the force and equilibrium polygons, that the stress diagram shall close and that its final side shall be parallel to the last member considered in the truss diagram. When there are more than two unknown stresses at a joint, the stress polygon for that joint cannot be drawn (Art. 16c). In some cases, the method of substitution (Art. 88) can then be employed; in others, the stress diagram can be continued from the right support, in the reverse order.

Thus, let Fig. 97 represent a triangular roof truss, fixed at the ends, having a load W at the peak and at each of the two adjacent joints, and a load of $W/2$ at each of the ends. The total load will then be $4W$. Letting s = length of span and taking

moments at the right support, the left reaction, R_1 is found thus :

$$R_1 s = s(W/2 + 3W/4 + W/2 + W/4),$$

$$R_1 = 2W;$$

and the right reaction,

$$R_2 = 4W - R_1 = 2W.$$

With any convenient load-scale of pounds or tons to the linear inch, lay off the force polygon for the loads and reactions, using the same letters to designate them as are employed in the truss diagram, and, in this case, taking the loads and reactions in regular clockwise order, as shown by the circle and arrow-heads. Thus, ab indicates the load $AB = W/2$, ma the reaction $R_1 = 2W$, etc. The closed force polygon for the loads and reactions will then be the line a to f and f to a .

The joint at the left support is the intersection of the reaction MA , the load AB , and the stresses, BG and GM . Beginning at the point m in the stress diagram, $ma = MA$ and $ab = AB$, their resultant being mb ; from b lay off bg and from m drawn gm , parallel respectively to BG and GM , thus closing the stress polygon, $mabgm$, for that joint. The magnitudes of the stresses in BG and GM will then be given by the lengths, on the load-scale, of the lines, bg and gm , respectively. To find the character of these stresses, the perimeter of the polygon is followed. Thus, as R_1 is known to act from m to a and the load $W/2$ from a to b , the stress in BG will act in the direction b to g , and that in GM from g to m . Since the former stress is toward the joint, BG is a strut, and, as the latter is from the joint, GM is a tie.

At the next joint, GB , BC , CH , and HG intersect; gb and bc are known and their resultant is gc ; from c lay off ch and from g draw hg , parallel respectively to CH and HG , and completing the polygon $bchgb$, which determines the stresses in CH and HG .

At the peak, HC , CD , DK , and KH intersect; hc and cd are known and their resultant is hd ; from d lay off dk and from h

draw hk , parallel respectively to DK and KH , completing the polygon $cdkhc$, which determines the stresses in DK and KH .

At the next joint and at the right support, the method is similar, the stress polygons being $delkd$ and $efmle$, respectively. The stresses acting at the mid-span joint will then all have been determined. Their force polygon is $mghklm$. The closing line of the stress diagram is ml , which is parallel to the final member ML .

Since the truss is symmetrical and each half is loaded in the same way, the line mg or ml is an axis of symmetry, and hence it is necessary to construct but one-half of the stress diagram. The methods described for this truss are general, and have therefore been given in detail. Familiarity with the principles involved will suggest to the student ways of shortening the work in some respects.

(b) *Method of Sections.* The stresses in the members of a framed structure may also be determined analytically by Rankine's method of sections.* While this method is, in general, complex, as compared with graphic processes, solutions by it are, in some difficult cases, simpler than those by graphics. Fundamentally, this method is based on the conditions of equilibrium for a system of coplanar forces. If each of the latter be resolved into two components, parallel respectively to axes XX and YY at right angles to each other, then, for equilibrium, the algebraic sum of all of the components in either direction, XX or YY , must be zero; and, further, the algebraic sum of the moments of the forces, about any axis perpendicular to the plane of the latter, must also be zero.

Thus, Fig. 97, let it be required to find the stresses in the members, CH , HG , and GM . Assume the truss to be cut into two sections by a plane passing through the line qt . Then, as shown in the lower diagram, there must be applied at the extremities of the severed members, the forces (Art. 21) $S_1 = ch$,

* "Applied Mechanics," London, 1869, p. 150.

$S_2 = hg$, and $S_3 = gm$, in order to maintain equilibrium in this section of the truss. The resultant of the forces at the left support is $R_1 - W/2 = 3/2 W$, and the system of external forces now acting on this section of the truss is: $3/2 W$, W , S_1 , S_2 , and S_3 . Assume, for simplicity, that the upper chord is inclined at 45° to the lower chord, and that the web members are at right angles with the upper chord. Let x and y be the horizontal and vertical distances, respectively, from the left support to the point of application of the load W , z the corresponding diagonal distance, and v the distance between the lines of action of S_1 and S_2 , and the point 3 the intersection of the span and the line of action of W .

Take moments about the left support. The lines of action of the forces, $3/2 W$, S_1 , and S_3 , pass through this point, and their moments are therefore zero. The moment of W is positive, and that of S_2 is negative. For equilibrium, the algebraic sum of the moments must be zero. Hence:

$$S_2 \times z = W \times x,$$

$$S_2 = W \times \frac{x}{z} = W \sin 45^\circ.$$

Similarly, taking moments about the point 2, where the load W is applied:

$$S_3 \times y = \frac{3}{2} W \times x,$$

$$S_3 = \frac{3}{2} W \times \frac{x}{y} = \frac{3}{2} W \tan 45^\circ.$$

Finally, taking moments about the point 3:

$$\frac{3}{2} W \times x = S_1 \times v + S_2 \times v,$$

$$S_1 = \frac{3}{2} W / \sin 45^\circ - S_2.$$

83. Roof Trusses: Definitions; Loads. Roof trusses are framed structures which support the roof of a building; they are set parallel, in vertical planes, and rest on the walls. Both ends of

the truss may be *fixed*, or one end may be *free* to move horizontally, in order to provide for the variation in length due to expansion and contraction from change in temperature. The upper chord, as in a triangular truss, may be composed of two straight *main rafters*; or this chord may be *hipped*, having a double slope; or the joints of both chords may be located in arcs of circles, as in the *crescent truss*. The lower chord is called the *tie-rod*; the *rise* is the height of the highest point of the truss, measured from the span. The web members, which connect the upper and lower chords, may be either struts or ties depending on their location and the manner of loading.

As shown in Fig. 97, the truss members are so connected as to form a series of triangles. This is essential in order to prevent deformation of the truss, as a triangle, loaded at one or all of its vertices, will not change its shape so long as the lengths of its sides remain constant, which is not the case with polygons of a greater number of sides connected by pivotal joints.

The loads which a roof truss is designed to sustain are: the *dead load*, *i.e.* the weight of truss and roof, the *snow load*, and the *load due to wind pressure*. The dead and snow loads produce a definite stress, tensile or compressive and unchanging in character, in each member. Since the wind may come from either side, the stresses arising from its pressure are variable in kind. Separate stress diagrams are constructed for the two cases, and the *maximum stress*, for all conditions of loading, is found for each member. When, under dead load, a member is subjected to tension, and, under wind loads, to compression, the stress, under the *combined loads*, is the resultant found by taking the algebraic sum of the two, tension being considered as positive and compression as negative.

The *weight of the truss* must be estimated from those of similar trusses whose weights are known. Owing to this, the first design of a complex truss may necessarily be tentative, since the size and weight of the members depend on their respective loads,

of which the truss weight forms a part. For preliminary estimates, Trautwine * states that "the *weights of steel trusses*, in pounds per square foot of building space covered, may be taken at $(0.05 \text{ to } 0.08) \times \text{span in feet}$, according to design and loading. Those of *wooden trusses*, with wooden, iron, or steel tension members, may be taken at from one-tenth to one-fifth less."

The approximate weight of the roof covering, per square foot of roof surface, may be estimated from the following table :

Shingles	2 pounds
Slates	9 pounds
Tin	1 pound
Corrugated iron	1 to 3.75 pounds
Tiles	7 to 30 pounds
Felt and gravel	8 to 10 pounds
Sheathing, 1 inch thick	2 to 5 pounds
Purlins, wood	1 to 3 pounds
Purlins, iron	2 to 4 pounds
Rafters, jack	1.5 to 3 pounds

Division of dead load. The *purlins* are beams, supported usually on the corresponding joints of the upper chords or main rafters of consecutive trusses being thus above and transverse to the latter. On the purlins, rest the *jack rafters*, parallel to the main rafters, and carrying the *sheathing, shingles*, etc. The purlins, therefore, transfer the weights of the roof covering and the snow to the joints of the upper chord, thus avoiding bending stresses in the latter.

The joints (*apexes* or *panel-points*) of the upper chord divide the roof into *panels*, and at each apex there is assumed to be concentrated one-half of the load on each of the panels adjacent to it. The weight of the truss is also assumed, without material error, to be divided among the apexes in proportion to the lengths of their adjacent panels. If, for example, there are four panels of equal length, as in Fig. 97, one-fourth of the

* "Civil Engineer's Pocketbook," New York, 1907, p. 713.

truss weight is applied at the peak, one-fourth at each of the adjacent apexes, and one-eighth at the joint at each support. The dead load at an apex consists thus of its proportion of the truss weight and of the weight of the roof covering on a rectangular strip of roof, whose limits are the median lines between the given apex and those adjacent to it on the four sides. When there is a ceiling or a line of shafting carried by the lower chords of the trusses, the weights in either case are considered as a dead load on the lower joints.

The *snow load*, depending on the latitude, varies from 10 to 30 pounds per square foot of horizontal projection of the roof surface; it is about 20 pounds in the latitude of New York City. This load is not considered for roofs at an angle with the horizontal of 60° or above. The apex loads due to *wind pressure* are discussed in Arts. 85 and 86.

84. Determination of Dead- and Snow-load Stresses. From the preceding article, it will be seen that, in the determination of the stresses in a roof truss due to dead loads, there are considered, in general, only the series of parallel, vertical loads assumed to be applied at the apexes of the upper chord, the sum of these loads being equal to that of the weights of the truss and the roof covering. When the panels have all the same inclination to the horizontal, as in Fig. 97, their horizontal projections, and therefore their snow loads, will be the same and will bear a constant relation to the dead load. The snow loads may, therefore, be omitted from the diagram and the stresses due to them computed from the dead-load stresses. When, however, as in Fig. 100, the panels, although equal in length, have different inclinations, their horizontal projections will differ and a separate stress diagram should be drawn for the snow loads.

(a) *Symmetrical truss, symmetrically loaded.* Figure 97 shows a triangular roof truss of this type under dead load. The apexes are the joints, *A, B, C*, etc.; the panels of the upper

chord extend from A to B , B to C , C to D , etc.; the dead load at apex A is one-eighth of the truss weight plus one-half of the weight of the roof covering on panel AB ; the load at apex B is one-fourth of the truss weight plus one-half the weight of the covering on panels AB and BC ; the reaction at apex $A =$ reaction at apex $B = R_1 = 2W = R_2$; the net or effective reaction at joint $A =$ net reaction at joint $B = R_1$ minus the load $= 2W - 1/2W = 3/2W$.

(b) *Unsymmetrical truss, unsymmetrically loaded.* Figure 98 gives the diagrams for a form of truss suitable for the "saw-tooth" roofs used in factories for obtaining overhead light, without direct sunlight, the windows of the saw-tooth usually facing the north.

The truss weight is divided among the panels, AB , BC , and CD , in proportion to the lengths of the latter; there is no snow load on panel AB ; the load at apex B is one-half of those on panels AB and BC ; at apex C , one-half those on panels BC and CD ; at joints D and A , one-half those on panels CD and AB , respectively.

The general method of determining the stresses is that given in Art. 82a and Fig. 97, except that the operation is not begun at the left support but at the first apex to the right of it, since, at the former apex, there are three unknown stresses. The

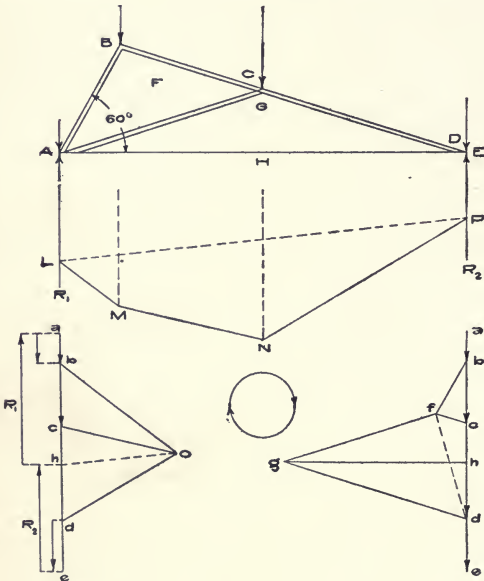

FIG. 98.

those on panels BC and CD ; at joints D and A , one-half those on panels CD and AB , respectively.

The general method of determining the stresses is that given in Art. 82a and Fig. 97, except that the operation is not begun at the left support but at the first apex to the right of it, since, at the former apex, there are three unknown stresses. The

reactions, R_1 and R_2 , are first determined either analytically or by drawing the force polygon $a - e$ with pole O and the corresponding equilibrium polygon $L - P$, the closing line, PL , of which gives the direction of the ray Oh and hence the magnitude of the reactions. The data as to the method and results are :

APEX	KNOWN	RESULTANT OF KNOWN STRESSES	STRESS POLYGON	FOUND
B	BC	fd	$bcfb$	$cf (-), fb (-)$
C	CD, FC		$cdgfc$	$dg (-), gf (-)$
D	DE, EH	dh	$dhgd$	$hg (+)$
A	all		$habfgh$	

(c) *Truss with loads on both upper and lower chords.* In addition to the usual dead load on the upper chord, a truss may carry also the weight

of a ceiling beneath it. The latter weight is considered as divided among the apexes of the lower chord, each of such apex loads being the sum of the ceiling weights on one-half of each of the adjacent panels. The stress diagram for the dead loads is then constructed to include these additional loads.

Thus, let Fig. 99 represent a symmetrical triangular truss carrying loads on both chords. The forces, R_1 and R_2 , are the

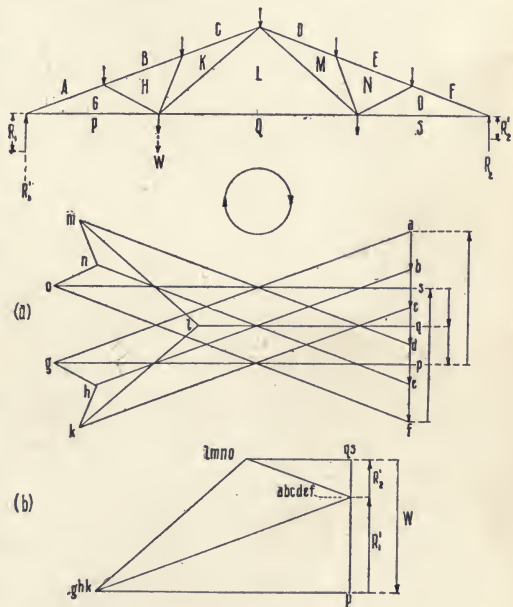

FIG. 99.

effective reactions, so that no loads are shown at the supports; the loads, PQ and QS , are equal, the additional load W , shown by dotted lines, being disregarded for the present. In constructing the stress diagram (a), the upper-chord loads, AB to EF , are first laid out on the load-line af ; then, the total reaction at the left support corresponds with the distance fs measured upward; the lower apex loads, SQ and QP , are designated by sq and qb , acting downward on the load line; and, finally, pa , acting upward, represents the total reaction at the right support. From the points thus determined on the load line, the stress diagram is laid out as described previously for dead loads, except that, in this case, the loads on the lower chord are included. For example, the stress polygon for the upper apex nearest to the left support is $abhga$; that for the similar apex on the lower chord is $ghklqpg$.

Again, the lower chord may have a concentrated load at one apex, such as that of shafting in a machine shop. In this case, the simplest way is to draw a diagram for the truss when carrying only this concentrated load, and to add algebraically the stresses thus determined for each member to the similar stresses found from the diagram for dead loads. Thus, let the truss, Fig. 99, be considered as carrying only the load W at the lower apex nearest to the left supports, the weight of the truss and that of the roof covering being disregarded. The reactions, R_1' and R_2' , are first determined, either analytically or by the force and equilibrium polygons. The distance pa on the load line of the stress diagram (b) represents R_1' ; since there are no loads on the upper chord, the point a is also the location of the points, b, c, d, e , and f ; fs then corresponds with the right reaction R_2' , and as s and q lie at the same point, qp designates the load W . The stress diagram is now constructed by the usual method. It will be found that there is no stress in any diagonal except KL , since the load W produces only tension in this diagonal and in the lower chord and compression in the

rafters, which stresses are the same in character as those arising from the dead load of the weights of the truss and roof covering.

85. Wind Pressure on Roofs. — But little is known definitely with regard to the general direction, and the intensity of wind pressure upon inclined surfaces such as roofs. The usual practice, in determining the stresses in roof trusses, assumes a horizontal direction of the wind with a pressure of 30 to 40 pounds per square foot on a surface normal to that direction. On this basis, the normal pressure on the roof panel is then computed by either of the following formulæ, in which θ is the inclination of the panel to the horizontal, p_n is the normal pressure per square foot on the roof surface, and p_h is the similar pressure on a vertical plane by a wind moving horizontally :

(a) *Duchemin's formula* :

$$p_n = p_h \frac{2 \sin \theta}{1 + \sin^2 \theta}.$$

(b) *Hutton's formula*, deduced by him from extended experiments :

$$p_n = p_h (\sin \theta)^{1.84 \cos \theta - 1}.$$

Taking $p_h = 40$, the latter formula gives :

θ°	p_n	θ°	p_n	θ°	p_n
5	5.1	35	30.1	65	40.
10	9.6	40	33.3	70	40.
15	14.2	45	36.0	75	40.
20	18.4	50	38.1	80	40.
25	22.6	55	39.4	85	40.
30	26.5	60	40.0	90	40.

For intermediate values of θ , the corresponding value of p_n may be obtained by interpolation. For values of 50° and upwards, the results from the two formulæ, at this value of p_h ,

are very close ; below that angle, Duchemin's formula gives considerably higher values.

86. Determination of Wind-load Stresses.— The stresses arising from wind pressure are determined independently, without

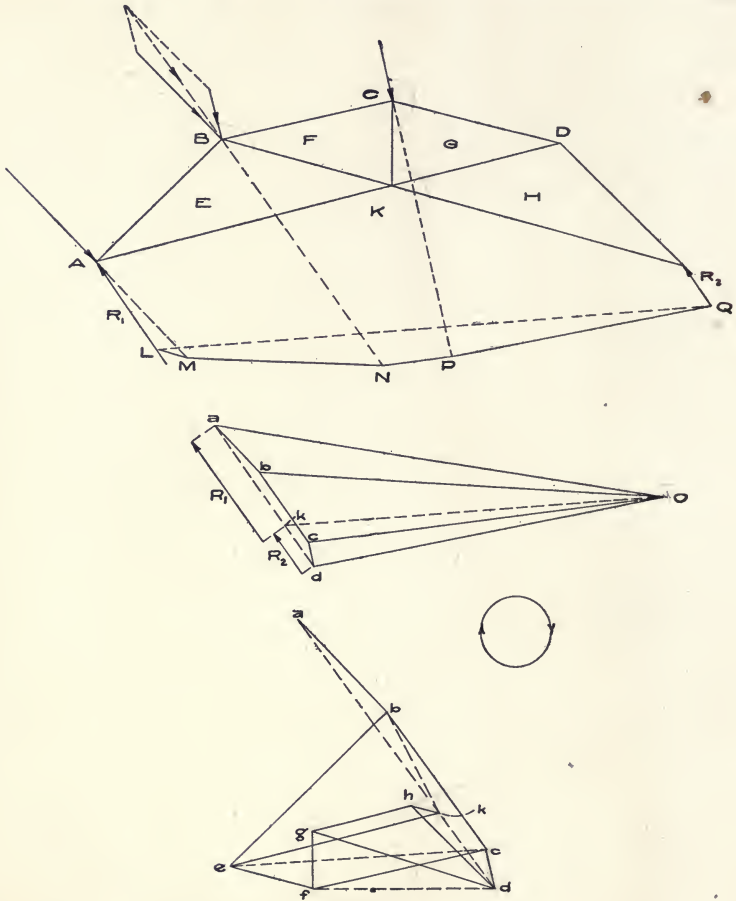

FIG. 100.

regard to those due to dead and snow loads. The loads on the windward side of the truss are assumed to be normal to the roof surface ; the lee side is unloaded. With this modification, the

general method of Art. 82 *a* is applicable, except as to the determination of the reactions. Two cases as to this are presented: short trusses whose ends are fixed in the walls, and, secondly, iron or steel trusses of long span which have one end free to provide for expansion or contraction and the consequent movement caused by changes in temperature.

Since the wind loads and the reactions form a system of external forces in equilibrium, the sum of the components of the reactions, in the direction of the wind loads, must be equal to the sum of the latter. Hence, with a truss having both ends fixed, the reactions are assumed to be parallel to the wind loads, or to the resultant of those loads. When but one end is fixed, the free end is frequently supported upon rollers, in which case the reaction at that end is vertical. Knowing this and the point of application of the other reaction, the direction of the latter and the magnitude of both can be found from the force and equilibrium polygons for the loads and reactions.

(*a*) *Fixed Ends.* Figure 100 gives the diagrams for a hipped truss having both ends fixed in the supporting walls. The panels have each a length of 14 feet; the trusses are spaced 12 feet apart; the inclination to the horizontal is 45° for the lower, and 15° for the upper, panels, giving—from the table, Art. 85—values of p_n of 36 and 14.2 pounds, respectively. Taking the left as the windward side, the wind loads, normal to the roof, will be:

$$\begin{aligned} \text{panel } AB: 14 \times 12 \times 36 &= 6048 \text{ pounds} \\ &\text{applied at } A, \quad 3024 \text{ pounds} \\ &\text{applied at } B, \quad 3024 \text{ pounds} \end{aligned}$$

$$\begin{aligned} \text{panel } BC: 14 \times 12 \times 14.2 &= 2386 \text{ pounds} \\ &\text{applied at } B, \quad 1193 \text{ pounds} \\ &\text{applied at } C, \quad 1193 \text{ pounds} \end{aligned}$$

The two loads at apex *B* are combined into a single resultant load, *BC*, by the parallelogram of forces; the latter load, those

acting at A and C , and the two reactions form the system of external forces acting on the truss, so far as wind pressure alone is concerned.

To determine the reactions, draw, to any convenient scale of loads, the force polygon $a \dots d$ with pole O and the corresponding equilibrium polygon $LMNPQ$. The magnitude and direction of the two reactions are shown by the dotted line ad ; the ray Ok , drawn parallel to the closing side QL , intersects ad at k , giving the magnitude of R_2 as dk and that of R_1 as ka .

The construction of the stress diagram is begun by drawing again the polygon $abcdka$, preferably on a larger scale. Then, starting at the left support, the loads and stresses acting are KA , AB , BE , and EK , of which KA and AB are known and are given in the stress diagram by ka and ab , whose resultant is kb . Lay off be and ke parallel, respectively, to BE and EK . The stress polygon for the apex A is then $kabek$ and the stresses determined are be and ek , the former compressive, the latter tensile. The stresses and loads, if any, at each apex are treated similarly and the stress diagram is thus completed. The stress polygons for the apexes $A \dots E$ are: $kabek$, $ebcfe$, $fcdfg$, $gdhgf$, $hdkh$.

Since the truss is symmetrical, it is evident that, if the right became the windward side, the stresses found for the wind on the left would be transferred to the corresponding members in the other half of the truss.

(*b*) *One Free End*, Fig. 101, represents a triangular roof truss, having the left end fixed and the right end free to move and supported on rollers; the upper panels are of equal length.

Assume the wind to be on the left side. There are two ways of determining the reactions at the supports. *First Method*: the right reaction R_2 is vertical owing to the rollers, and, since the panels B and C are uniformly loaded, the resultant of their apex loads due to the wind passes through the middle apex z and is normal to the roof. This resultant is held in equilibrium by the two reactions. Therefore, prolong the lines of action of R_2

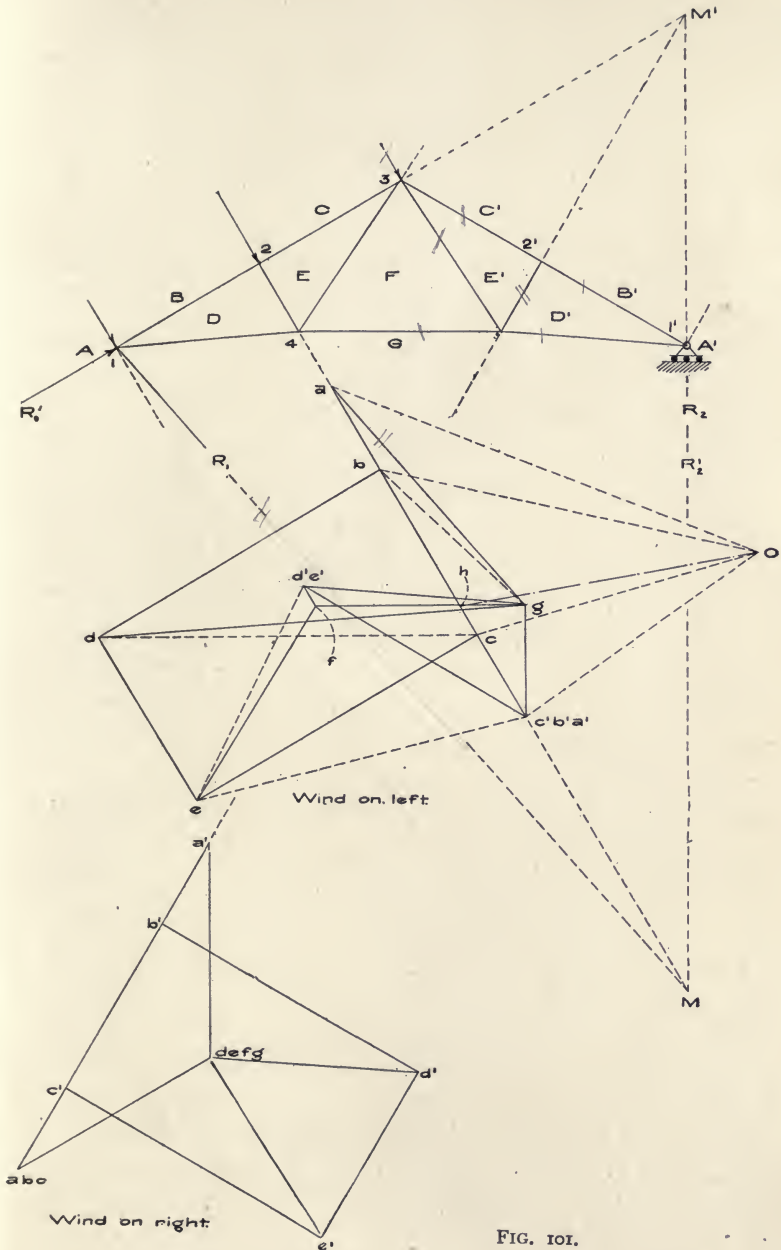

FIG. 101.

and the load-resultant, zM , until they meet at the point M , and from M draw the line M_I through the point of application of R_1 . The lines M_I and M_I' are then the lines of action of R_1 and R_2 , respectively. On M_2 , lay off the loads, ab , bc , cc' ; from a draw ag parallel to M_I and from c' draw $c'g$ parallel to M_I' . Then, since ac' = total wind load, $ga = R_1$ and $c'g = R_2$.

Second Method: assume at first that the reactions are parallel to the loads; draw the force polygon ac' with pole O for the loads and reactions and the corresponding equilibrium polygon (not shown); the closing side of the latter determines the direction of the ray Oh , which gives $R_1 = ha$, and $R_2 = c'h$, on the assumption as above. R_2 is, however, vertical and must therefore be equal to the vertical component of $c'h$, i.e. $c'g$; from g draw $ga = R_1$.

The stress diagram is constructed by the general method used for Fig. 100, except that the joints are not taken in clockwise rotation throughout, since there would then be three unknown forces at the peak joint 3. The order followed is: 1, 2, 1', 2', 3, and finally 4, to determine the stress in the last member FG . It will be observed that there is no stress in the member $D'E'$. The stress polygons, in the order named, are: $gabdg$, $dbced$, $a'gd'b'a'$, $b'a'e'c'b'$, $ecc'e'fe$, $gdefg$.

Using the first method, as given above, to determine the reactions with the wind on the right, draw the vertical line $r'M'$ from the right support until it intersects at M' the line of action, $z'M'$, of the resultant of the wind loads; from M' draw $M'I$ to the point of application of R_1' . On $M'z'$ prolonged, lay off the loads, $a'b'$, $b'c'$, and $c'c$; from a' drop the perpendicular $a'g$ intersecting at g the line ag drawn parallel to $M'I$. Then, $ag = R_1'$, and $ga' = R_2'$. The stress diagram is then constructed by the same methods as before, except that the operation is reversed, the order of the stresses being non-clockwise. As the line of action of R_1' coincides with the main rafter, there is no stress in the members, DE , EF , FG , and GD .

87. Maximum and Minimum Stresses. While the dead load always acts on a truss, the loads due to snow and wind are variable. Hence, each member will be subjected to changing stresses, and, as it should be designed, not only for the maximum stress endured, but also for the range of stress through which it passes, it is necessary to know both the maximum and minimum stresses in each case.

Therefore, after finding the stresses from the dead and snow loads and from the wind on each side separately, the results should be tabulated and the maximum and minimum stresses ascertained for each member. The *minimum stress* is that produced by the dead load, except when a stress due to wind is of the opposite character, and the algebraic sum of the two is less than the dead-load stress. The *maximum stress* is the larger of the two stresses, found by taking the algebraic sum of the wind stress on the right or left, and the stresses due to dead and snow loads. As stated previously, tensile stresses are taken as positive, and compressive stresses as negative, in obtaining the algebraic sum.

Thus, in Fig. 101, let the span be 35 feet; the inclination of the rafters, 30° to the horizontal; the four panels be equal in length; and the trusses be of steel and spaced 12.5 feet apart. Assume the weight of the roof covering as 13.5 pounds per square foot of roof surface, and the snow load as 15 pounds per square foot of horizontal projection of the roof surface. Then, the length of a rafter will be 20.21 feet, and, for each truss :

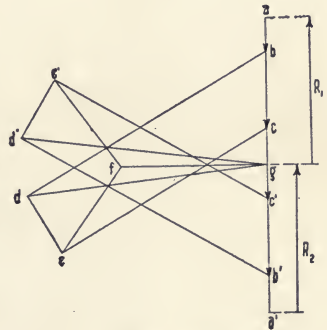

FIG. 101 a.

Area of roof covering	505.25 sq. ft.
Area of panel	126.31 sq. ft.
Area of horizontal projection of roof	437.5 sq. ft.

Weight of roof	6821	lb.
Weight of truss (Art. 83) = $.08 \times 35 \times 437.5 =$	1125	lb.
Dead load, total = $6821 + 1125 =$	7946	lb.
Dead load, apex = $7946/4 =$	1986.5	lb.
Dead load, reaction = $7946/2 =$	3973	lb.
Snow load, total = $437.5 \times 15 =$	6562.5	lb.
Snow load, apex = $6562.5/4 =$	1640.6	lb.
Ratio of stresses, snow load to dead load = $1640.6/1986.5 =$	0.826	
Wind pressure, normal, per square foot (Art. 85)	26.5	lb.
Wind load, normal, total = $126.31 \times 2 \times 26.5 =$	6694.4	lb.
Wind load, normal, apex = $6694.4/2 =$	3347.2	lb.

The dead-load diagram is shown in Fig. 101 *a*. Using a scale of 1000 pounds to the inch, this diagram and those of Fig. 101 give the stresses in pounds in the members, as follows:

TRUSS MEMBERS	STRESS DUE TO				MAXIMUM STRESS	MINIMUM STRESS
	Dead Load	Snow Load	Wind on			
			Left	Right		
<i>BD</i>	-7330	-6055	-6550	-3800	-19,935	-7330
<i>B'D'</i>	-7330	-6055	-5750	-4700	-19,135	-7330
<i>CE</i>	-6330	-5229	-6550	-3800	-18,109	-6330
<i>C'E'</i>	-6330	-5229	-4700	-5750	-17,309	-6330
<i>GD</i>	+6380	+5270	+8230	0	+19,880	+6380
<i>G'D'</i>	+6380	+5270	+4150	+4180	+15,830	+6380
<i>GF</i>	+3900	+3221	+3750	0	+10,871	+3900
<i>DE</i>	-1720	-1421	-3350	0	-6,491	-1720
<i>D'E'</i>	-1720	-1421	0	-3350	-6,491	-1720
<i>EF</i>	+2680	+2214	+4680	0	+9,574	+2680
<i>E'F'</i>	+2680	+2214	+550	+4150	+9,044	+2680

It will be seen that, with the majority of the members, the maximum stress is produced when the wind load is on the fixed side of the truss.

88. **Method of Substitution.** Let Fig. 102 represent a Fink truss, symmetrical and symmetrically loaded. The stress diagram can be constructed by the general method, excepting that part corresponding with apex 3, where there are three unknown stresses, DM , ML , and LK , to be determined.

Assume the members LM and MN to be replaced temporarily by the member PQ shown by a dotted line in the upper semi-truss diagram. From the latter, draw the stress polygons, $cdpkhc$ for apex 3, $deqpd$ for apex 4, and $fkpqof$ for apex 7, thus determining KP and QO , which correspond with KL and NO , respectively, in the original diagram. Re-

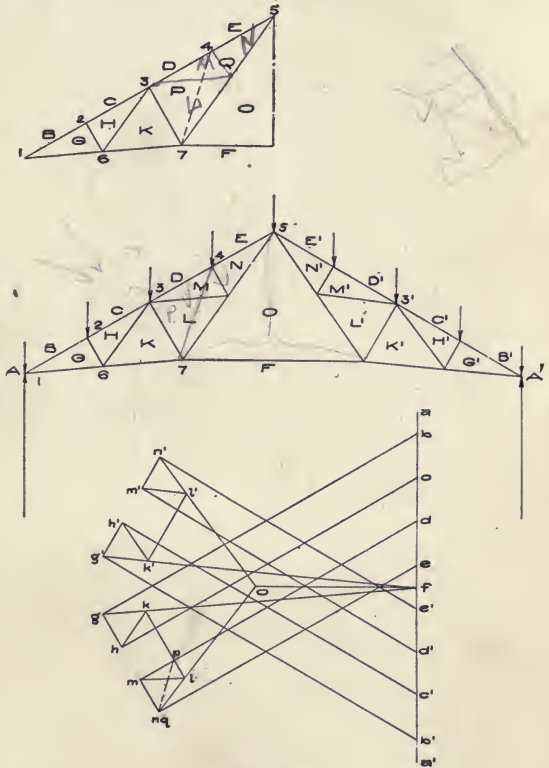

FIG. 102.

turning to the latter, the unknown stresses at apex 3 are now DM and ML , and the stress polygon $cdmlkhc$ can be constructed. The remainder of the stress diagram presents no difficulties.

There are other more or less complex solutions of this problem. The method of substitution is, however, both simple and general, being applicable when the panels are unequal in length and unsymmetrically loaded.

89. Braced Cantilevers. The following analyses by the method of reciprocal diagrams show the stresses in typical forms of framed or braced cantilevers.

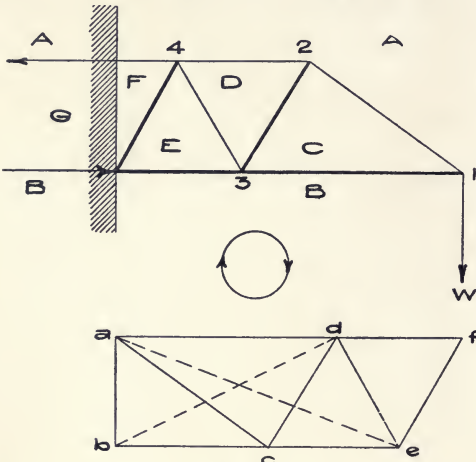

FIG. 103.

(a) In Fig. 103, the cantilever consists of a horizontal lower chord, an upper chord partly horizontal and partly inclined, and diagonal web members; the only load considered is the weight W at the end of the cantilever.

The stress diagram is begun at the apex

on the line of action of W . The stress polygons are:

apex 1, $abca$; apex 2, $acda$; apex 3, $bedcb$; apex 4, $adefa$. At apex 3, the known stresses are DC and CB ; their resultant is db . From b draw be and from d draw de , parallel to BE and ED , respectively. A similar method is followed at apex 4. The stress fa corresponds with the tensile stress GA in the support.

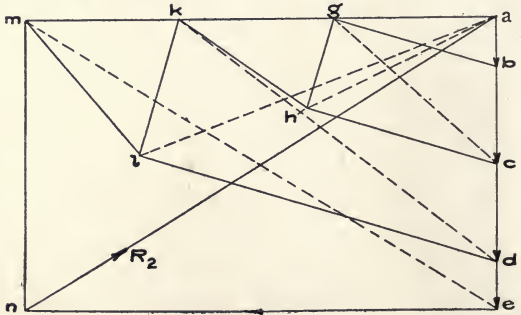
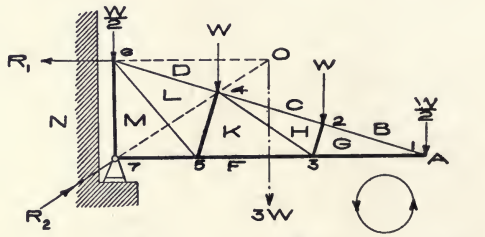

FIG. 104.

(b) Figure 104 gives the diagrams

for a cantilever truss such as would be used for an overhanging roof. The panels are equal in length and the dead load only is considered, being divided among the apexes as before. The apex loads are laid off on the line $a-e$ and the stress diagram is constructed by the general method. For the apexes 1-7, the stress polygons are: $abgfa$, $bchgb$, $ghkfg$, $cdlkhc$, $fklnmf$, $denmld$, $fmmf$.

Assuming a horizontal supporting tie, $R_1 = en$, at the upper extremity of the truss, its line of action intersecting that of the resultant of the loads at the point O , the line $O7$, drawn through the point of application 7 of the reaction R_2 , is the line of action of the latter, whose magnitude is given by the line nf in the stress diagram.

(c) Figure 105 shows a V-shaped cantilever with lattice bracing. Only the load applied at the end is considered, and the cantilever is assumed to be secured to the wall. The same numbers are used to designate the members in both diagrams; the joints are marked by capital letters; the lettering of the stress diagram is arbitrary.

To construct the stress diagram, draw $W = ab$, and from a and b lay off 1 and 2, meeting at e and parallel respectively to 1 and 2 in the truss diagram. The stress polygon $abea$ determines the stresses in the members 1 and 2. The stresses at apex C are 1, 3, and 4, of which 1 is known; the corresponding stress polygon is $ebde$, which determines 3 and 4. Stresses 5 and 6 are found similarly for joint D . At joint E there are four stresses, 5, 3, 7, 8, of which $5 = ce$ and $3 = db$ are known. Transfer ce to fd ; the resultant of fd and db is fb . From f draw $hf = 8$ and from h lay off $bh = 7$, thus determining stresses 7 and 8. The four stresses at each of the joints F , G , and H , are treated similarly, the two known stresses being combined and their resultant used to form a stress triangle with the two remaining stresses. Finally, at the joints K and L , the two stresses acting at each are known; their resultants are, respectively, nb and an ;

and the equal and opposite forces required to support the cantilever are the tensile force $M = bn$ and the reaction $N = na$,

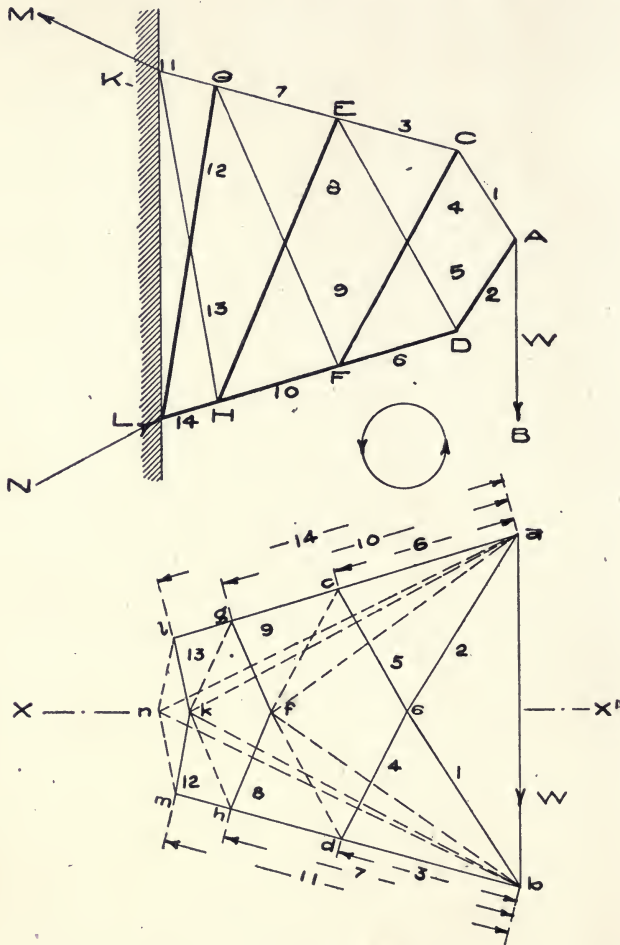

FIG. 105.

respectively. Since the stress diagram is symmetrical about the horizontal axis XX' , it is necessary to draw only one-half of it, due regard being had to the character of the stresses.

90. Cranes. Framing finds frequent use in crane construction.

Figure 106 shows a crane boom of this character, having a load W at the peak. For clearness, the dead load due to the weight of the crane is disregarded.

The stress diagram can be readily constructed by the general method.

The stress polygons are: joint A , $abca$; C , $cbde$; D , $acdea$; E , $edbf$; F , $aefga$; G , $agha$; H , $hgfbkh$; K , $kblk$. The upper chord and the diagonals are shown to be in tension; the lower chord, the radials, and the strut 13 , in compression. The load and the thrust produced by its leverage are sustained by the reactions, R_1 and R_2 , at the supports, R_2 being evidently equal to $R_1 + W$.

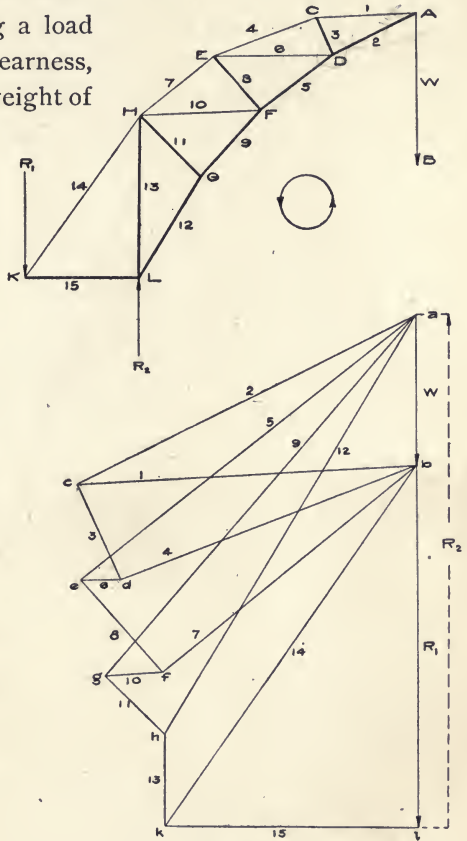

FIG. 106.

91. Accuracy in Drawing; Check on Results. In constructing stress diagrams for which, as with roof trusses, a usual scale is five or six tons to the inch, it is evident that accurate drawing is essential. The lines of the diagram should be as narrow as possible, and the pencil used should be hard, finely pointed, and held always at the same inclination to the paper. Especial care should be exercised in drawing a line parallel with another.

The fundamental check on the results is that the final line of the stress diagram — usually representing one of the members at the peak of a roof truss — shall be accurately parallel to its corresponding member. In some cases, it may be well also to find analytically the stress in one of the final members, as the rafter at the peak, and compare the results with those determined graphically.

PROBLEMS

74. The rafters of a triangular roof truss (3 members) of span s are inclined at the angle θ to the horizontal. Let w be the weight per lineal foot of the rafters and w' the similar weight of the uniformly distributed load of roof covering which they sustain. Treating the rafter as a beam, find, by force triangles, the compressive stress in the rafter at the middle of its length, the tension in the chord (neglect weight of chord), and the vertical pressure on each support.

75. Find the dead-load stresses in the members of a steel roof truss similar to that shown by Fig. 102, except that the lower chord is horizontal. Data: span, 40 feet; rise, 12 feet; trusses spaced 12 feet apart, c. to c.; weight of roof covering, 13.5 pounds per square foot of roof surface; weight of truss in pounds = $0.08 \times$ span in feet \times square feet of building space covered by roof supported by one truss.

76. In a crescent roof truss, the joints of both chords lie in arcs of circles which meet at the supports; corresponding joints of the upper and lower chords are joined by braces radiating from the centre of the upper arc; diagonal braces, inclined toward the peak, connect each upper joint with the next outer one in the lower chord.

Find the dead-load stresses in a steel truss of this type. Data: radius of arc of upper chord, 25 feet; of lower chord, 39 feet; span, 47 feet; 6 equal panels in each chord; trusses spaced 16 feet, c. to c.; truss- and roof-covering weights as in Problem 2.

77. Deduce an expression for the pressure, P , in pounds per square foot, produced on a flat vertical surface by wind moving at a velocity of V miles per hour, and an expression for the similar normal pressure, P_n , on a roof surface inclined at the angle θ to the horizontal.

78. In Fig. 100, assume the left end of the truss to be free, and draw the stress diagrams for the wind on the right.

79. Find, by the method of sections, the stresses in the members of the braced cantilever, Fig. 103. Scale, 1 inch = 10 feet; $W = 500$ pounds.

80. In the braced cantilever, Fig. 105, assume an additional weight equal to W as suspended at the intersection of members 8 and 9. Modify the stress diagrams to suit these conditions.

81. Find the dead-load stresses in the cantilever roof truss, Fig. 104. Scale, 1 inch = 10 feet; trusses spaced 10 feet, c. to c.; weights as in Problem 2.

82. Determine the stresses in the members of the crane post, Fig. 106. Scale, 1 inch = 10 feet; $W = 5$ tons.

83. Find the stresses in this crane with this load, if all of the members between the diagonal GH and the apex A were replaced by a strut AG and a tie AH .

CHAPTER IX

BRIDGE TRUSSES

THE discussion which follows relates only to the fundamental principles governing the design of bridge trusses. The subject is complex, and, for full treatment of the many points involved, the student must consult special works covering it.

92. Bridge Trusses : Definitions. Bridge trusses are vertical framed structures which carry the dead and live loads in highway or railroad bridges. In general, they may be classed as *simple beams* resting upon two abutments, or as *cantilevers*, each anchored at the outer end and supporting, by links at the other, one extremity of a separate central truss, which joins the two cantilevers and forms with them the vertical framing of the completed bridge.

Each truss is composed of an *upper chord*, a *lower chord*, and *web members* joining the two. The chords may be horizontal and parallel, or one chord may be a broken line or have its joints lying in the arc of a curve. The web members may be either *vertical* or *diagonal*, the two systems being frequently employed in combination. In order to limit the main web members to a stress of but one character, *counterbracing* (*counter-ties* or *counter-braces*) is frequently used, the diagonals crossing to form *lattice bracing*. The joints of the web members with the chords divide the latter into *panels*; at these joints (*apexes* or *panel-points*), the loads are assumed to be concentrated. The *span* of a truss is the distance between the centres of the supports; the *depth* is the distance between the centres of the upper and lower chords.

To provide for wind stresses and to add to the stability of the structure, adjacent trusses are connected by *lateral bracing*, the latter forming essentially a horizontal truss composed of the two corresponding chords of consecutive vertical trusses and of horizontal web members. Wind or *sway braces* are also used in the form of vertical trusses between, and transverse to, the main trusses.

Bridge trusses are built either as *deck* or *through spans*. In the former, the roadway of the bridge rests on the upper chord of the truss; in the latter, on the lower chord. The through span gives more height in the clear below the bridge; the deck span offers better facilities for sway bracing.

In either case, the upper chord is always in compression and the lower chord in tension; the web members may be either ties or struts. *Tension members* may be eye-bars—flat bars with circular holes at each end for pin-joints—which are suitable for tensile stress only, or they may be virtually rigid built-up members. *Compression members* are always of the latter type. The *joints* or panel-points are either pin-connections, which give the members freedom for motion about the pin as a centre, or riveted joints, which are practically rigid. Trusses—either pin-spans or with riveted joints—are frequently called *girders*; and, similarly, riveted trusses are sometimes termed *lattice girders*, etc.

A bridge truss may be considered as a beam, and, as such, is subjected to bending moments, vertical shear, and deflection in a vertical plane. The *bending moment* at any section can be found as for a beam; from this moment, the *chord stresses* at the given section can be computed. In a truss with parallel chords, the vertical component of the stress in a diagonal is equal in magnitude to the *vertical shear*; the horizontal component of the same stress is the *chord increment*, *i.e.*, the addition to the chord stress due to this diagonal stress. *Camber* is the slight curve upward, from the ends to the middle, given to the

chords in order to compensate for their bending downward under load, so that, in any case, they shall be horizontal or curving above it.

93. Loads on Bridge Trusses. The loads carried by bridge trusses are: the dead load, the live load, and the loads due to wind and snow. The stresses produced by these loads are augmented by others resulting from the *impact* of the live load, from the initial tension given counter-ties to prevent vibration and increase stiffness, and from the various indeterminate strains produced by a curved or uneven track, by the shock of starting or stopping trains on the bridge, etc. The *maximum stress* is, in general, that due to the dead and live loads and to impact; the remainder are relatively of minor importance, and will not be treated herein.

The *dead load* comprises the weights of the trusses, the lateral and sway bracing, the floor beams, the longitudinal beams, and the floor of a highway bridge, or that of the trusses, bracing, floor-system, and tracks of a railroad bridge. General formulæ for the weight of railway bridges, including that of trusses or plate girders and that of the floor-system, cannot be readily constructed, except when the proposed bridge is of a type which has been frequently built. This follows since the loads, unit stresses, and the details of specifications differ in every case. With highway bridges, the difficulty is still greater, as they vary more widely in the service for which they are intended, and consequently in design. As to approximate formulæ, Merriman and Jacoby state:*

"The total weight or dead load of a highway bridge with two trusses may be expressed approximately by the following empirical formula:

$$w = 140 + 12 b + 0.2 bl - 0.4 l,$$

* "Roofs and Bridges," New York, 1898, Part II, p. 67. See also Part III under "Weight Estimates," and Trautwine, "Civil Engineer's Pocketbook," New York, 1907, pp. 731, 738.

in which w is the weight in pounds per lineal foot, b the width of the bridge in feet (including sidewalks, if any), and l the span in feet. . . . The total dead load of a railroad bridge for a standard gauge track may be approximately found from the following empirical formulas :

For single track, $w = 560 + 5.6 l$,

For double track, $w = 1070 + 10.7 l$.

For spans not exceeding 300 feet, these formulas give values usually a little larger than the actual weights, but sufficiently accurate for the determination of the stresses. For spans greater than 300 feet, they should not be used."

The *live load* is the moving load which crosses the bridge—foot passengers, vehicles, or railway trains, as the case may be. A *uniform live load*, per running foot of the entire bridge, produces, with the dead load, when the latter is considered as applied on the loaded chord only, a maximum load which is equivalent, in the stresses developed, to the aggregate considered as a dead load. Hence, the stress diagrams for dead loads and for uniform live loads are similar, and the stresses due to the latter may be computed from those produced by the former.

In practice, it is customary to make an allowance for *impact*. The added stress resulting from impact and vibration, and due to the live load, is indeterminate in some degree and varies with the character of the bridge. For a plate girder bridge, Waddell recommends for the coefficient of impact :

$$I = 400 / (L + 500),$$

in which I is the percentage of a given live-load stress to be added and L is the length in feet of the segment of the span which is covered by the live load when that stress is produced.

The maximum *wind load* is assumed to be that existing when the wind is horizontal, transverse to the bridge, and has a pressure of 30 to 40 pounds per square foot. It produces a horizon-

tal pressure on the exposed surfaces of one truss and of a train, if the latter be crossing the bridge. As a result, stresses are developed by direct pressure in the lateral bracing and transmitted to the chords of the main trusses, and, as the wind also tends to overturn both bridge and train, the stresses in these trusses are not the same as under similar dead and live loads in still air.

The *snow load* is negligible for open railroad bridges; for highway bridges, it is, for various reasons, assumed to be much less than for roofs.

As with roof trusses, all loads are assumed to be concentrated at the joints or panel-points. The method of transmitting to the joints all loads except the weights of the truss and bracing is the same in principle as that employed for roof trusses: transverse floor beams connect the corresponding joints of adjacent trusses; on these, longitudinal beams are laid; and, on the latter, the floor or the sleepers which carry the tracks. Hence, the load due to the floor and the live load resting on it can reach the trusses only through the supports of the floor beams at the joints. The weight of the truss may be relatively small as compared with the aggregate load — in which case, without material error (Art. 94 *b*), it also may be assumed to be divided proportionately among the panels of the loaded chord, and to be concentrated at the joints of the latter, although, for accuracy, it should be divided proportionately between the two chords. In practice, the weight of the floor-system is frequently considered as acting on the loaded chord only, and the remainder of the dead load is divided equally among the joints of both chords.

94. Determination, by Stress Diagrams, of the Stresses due to Dead Loads and to Uniform Live Loads, Panels not Counter-braced, The trusses discussed below represent the various systems of arrangement of the web members which are commonly used. Counter-bracing — which will be treated later — is not consid-

ered, as the character of the stress in any member is always the same for both the dead load and a uniform live load. The reaction shown at each support is the net or effective reaction, *i.e.*, the total reaction less the load on the joint at that support. (*A*) and (*B*) represent the truss diagrams for through and deck spans, respectively; the corresponding stress diagrams are marked (*a*) and (*b*). Since each truss is symmetrical and loaded symmetrically, the stress diagrams are constructed only for the lettered members of the truss diagram, extending from the left support inward, or about one-half of the truss. The stresses are taken in contra-clockwise order, the joints of the upper and lower chords being followed alternately, beginning at the left support. The loads may be considered either as dead loads, uniform live loads, or the two combined. They are applied to one chord only.

(*a*) *Warren truss*. Figure 107 shows the Warren triangular truss, in which the web members are all diagonals inclined about 60° to the horizontal and forming isosceles or approximately equilateral triangles with the panels of the chords.

The stress diagrams, (*a*) and (*b*), are constructed, as in Art. 84, by the general method. Thus, in (*a*), the distances, *kl*, *lm*, *mn*, etc., representing the loads, are laid off on the load-line, *ka*; the force polygon for the left half of the truss is then *kak* and the effective reaction at the left support is *ak*. The forces and stresses acting at that support are *AK*, *KB*, and *BA*; the corresponding stress polygon is *akba*; and *kb* and *ba* are, by inspection, tensile and compressive stresses, respectively. In this way, the stress polygon is constructed for each panel-point, taking the upper and lower panel-points alternately, until the entire stress diagram, or the portion required, is completed.

In both the through and deck spans, the upper chord is in compression and the lower in tension, as in the case of a simple beam; this result is produced by any dead or live load applied to a bridge truss. In both cases, the chord stresses increase

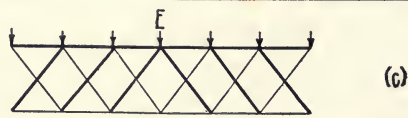
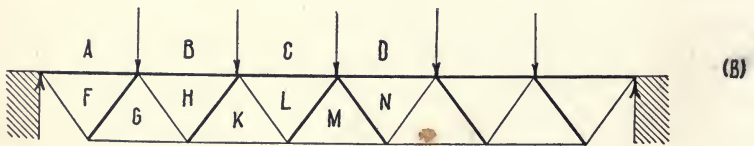
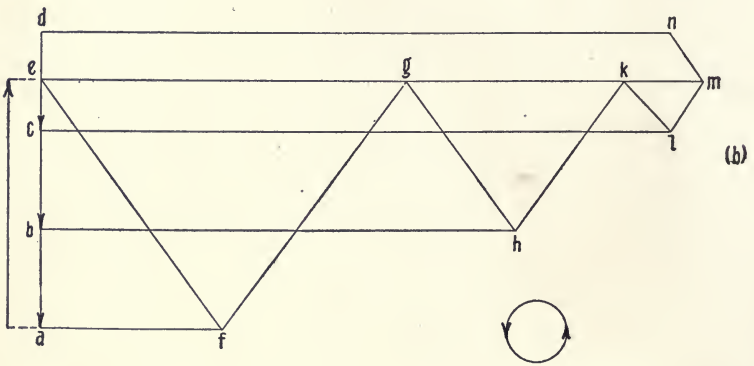
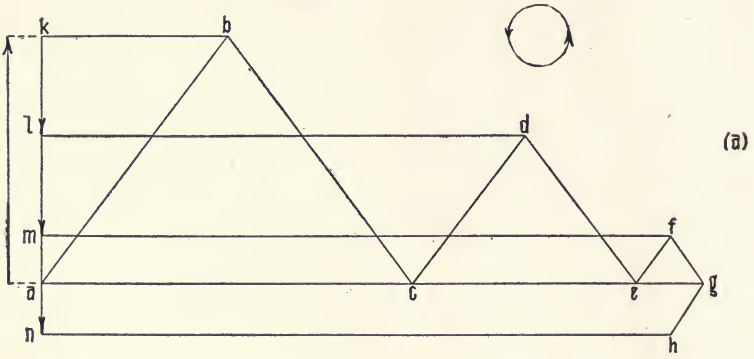
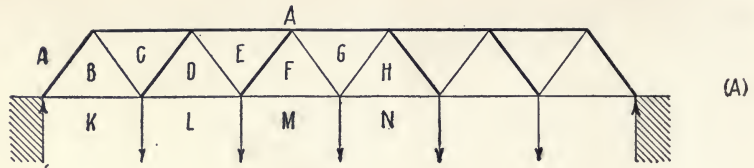

FIG. 107.

from the supports toward the middle, and the stresses in the web members, following the reverse order, increase from the centre of the span to the supports. This condition exists in any truss supported, as in this case, at the ends only, since, considering the truss as a simple beam uniformly loaded, the bending moment is a maximum at the centre and the vertical shear — to resist which is the primary function of the web members — is greatest at the supports.

Thus, in (*a*), the compressive stress in the upper chord increases from *ac* to *ag*, and the tensile stress in the lower chord, from *bk* to *fm*, while the alternately compressive and tensile stresses in the web members decrease from *ab* to *gf*. Similar results will be found for the deck span. The diagonals are, as stated, alternately struts and ties, the order changing at the middle, where, as in the six-panel trusses shown in Fig. 107, the two central web members are under the same kind of stress.

(*b*) *Howe truss*. Figure 108 gives the diagrams for through and deck spans of the Howe truss. It differs from the Warren type in that there are vertical as well as diagonal web members, and from the Pratt truss, Fig. 109, — which has also both verticals and diagonals, — in that, with the latter, the verticals are struts and the diagonals are ties, conditions which are the opposite of those in the Howe truss. For economy in construction and weight, the shorter web members of combined vertical and diagonal systems should, in general, be struts. The diagonals of the Howe truss are usually of wood, while the Pratt system is better adapted for trusses built wholly of steel.

The stress diagrams (*a*) and (*b*), for the through and deck spans, respectively, are drawn as with the Warren truss. In both spans, the stresses in the upper and lower chords, following the general rule, increase from the supports to the centre, while those in the web members grow larger in passing from the centre to the supports. Thus, in (*A*) and (*a*), the compressive stress in the chord increases from *ac* to *ae* and the

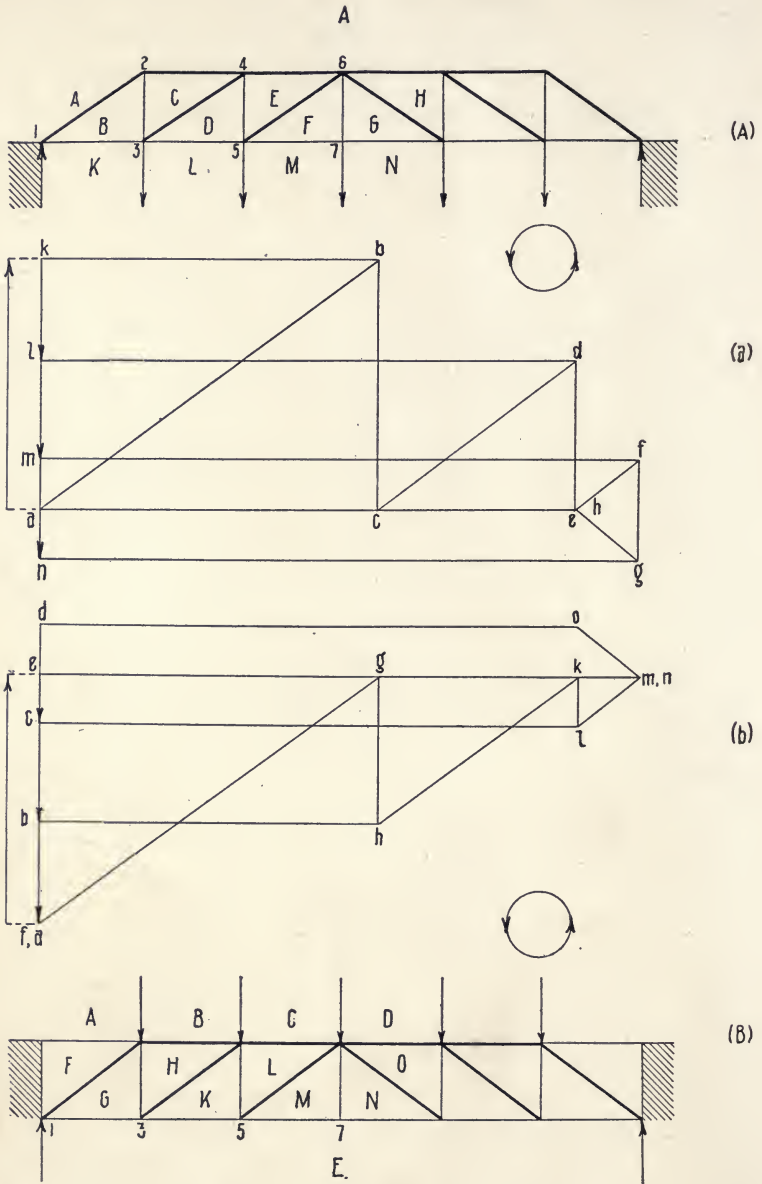

FIG. 108.

tensile stress from bk to fm , while the stress in the diagonals decreases from ab to ef and that in the verticals from cb to gf , being equal in the latter to the load MN only. In the deck span, the stress in the central vertical MN is zero, and that member serves simply to keep the middle panels of the lower chord from displacement or sagging. There are also in this span no stresses, from the loads shown in the diagram, in the vertical at the support and in the panel AF .

The effect produced on the stresses by a transfer of the loads from one chord to the other may be readily seen from the stress diagrams. Omitting the ineffective panel AF in (B) , the through and deck spans are identical in form and are fully comparable. Inspection of the stress lines for corresponding panels gives:

	(A)	(B)
Upper chords	{	$ac = bh,$ $ae = cl.$
Lower chords	{	$bk = ge,$ $dl = ke, \text{ etc.}$
Diagonals	{	$ab = fg,$ $cd = hk, \text{ etc.}$
Verticals	{	$cb = gh + \text{load at panel-point,}$ $ed = kl + \text{load at panel-point, etc.}$

From these data it appears that, so far as the chords and diagonals are concerned, it is immaterial with this truss whether the loads be applied on the upper or lower chords; and that, with regard to the verticals, the effect of loading the lower as compared with the upper chord is to increase the tensile stress in the vertical members by the amount of the load applied at each lower joint. These conclusions apply also to the Pratt truss discussed below, excepting that, as in it the verticals are struts, the compressive stress in each is increased, when the load is transferred to the upper chord, by the amount of the load applied at each upper panel-point. It will be seen, therefore,

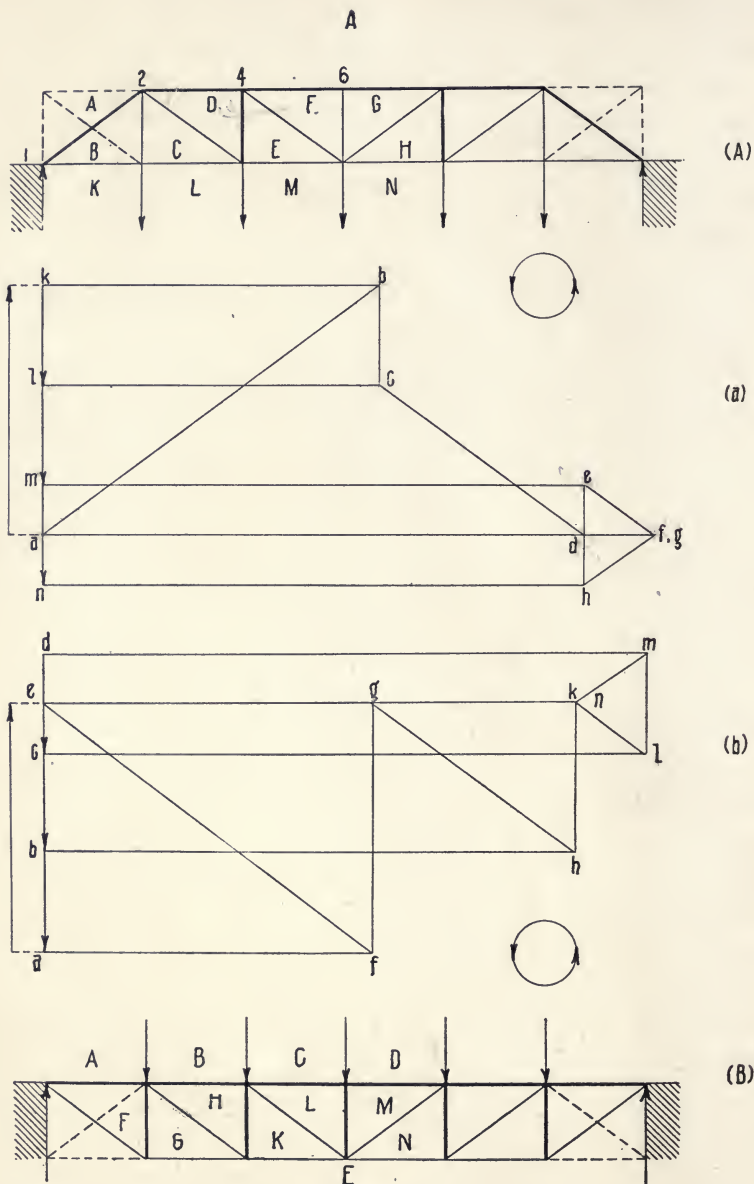

FIG. 109.

that, in apportioning the dead load among the panel-points of the loaded chord, the weight of the truss may be, in both cases, as above, equally divided, if allowance be made for the change in the stress of the verticals by a transfer of the load.

(c) *Pratt truss.* The diagrams for this truss are given in Fig. 109. The increase in the chord and web stresses follows the general rule previously given, except that, in (A), owing to the diagonal direction of the end post AB , the stress in BK is the same as that in CL , and the stress in CB is tensile and equal to the load LK . There is no stress in GF . The dotted lines in (A) and (B) show modifications sometimes made in the ends of this truss, the members, BA in (A) and GF and FE in (B), being omitted. Under these conditions, there is no stress in the lower panel BK of (A), which may also be omitted if the truss be supported at its upper extremity.

(d) *Bowstring truss.* In this truss, Fig. 110, one chord is a broken line with its panel-points arranged in the arc of a circular or parabolic curve, the members being straight; the web members may be either diagonals simply, as in the Warren truss, or diagonals and verticals, as in the Howe and Pratt systems, with corresponding variations in the character of the stresses to which these members are subjected. The effects of this virtual curvature of one chord, which thus forms an approximate arch, are, first, to make the stresses nearly uniform throughout each chord, as ab , ad , and af , and bk , cl , and em in (A); and, second, to reduce very materially the stresses in the web members, the diagonals especially, as shown in (A) by the decrease in ob , dc , etc., as compared with similar stresses in Fig. 109.

The equilibrium polygon for any system of forces requires no transverse web members to maintain equilibrium. Hence, the nearer the arc of the broken chord of this truss approaches, in curvature and height, the contour of the equilibrium polygon for the dead loads applied to the truss, the less, for these loads, will be the stress in the web members; the less the need of

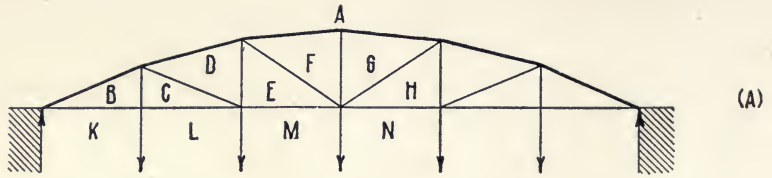

(A)

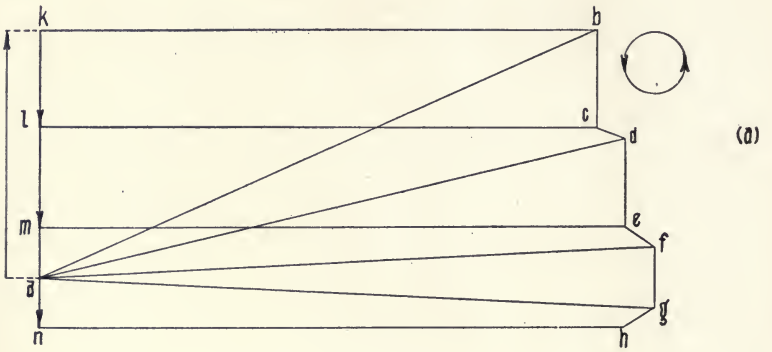

(a)

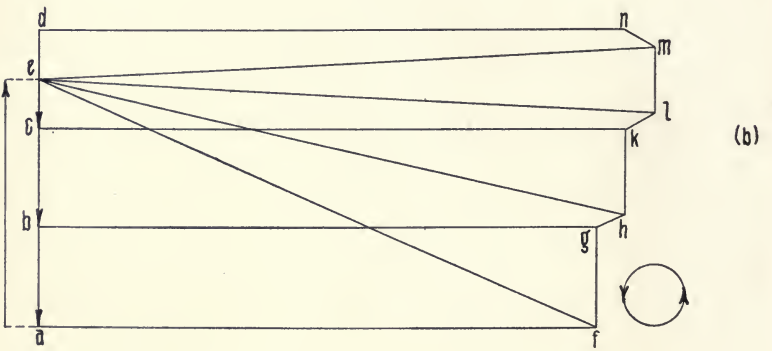

(b)

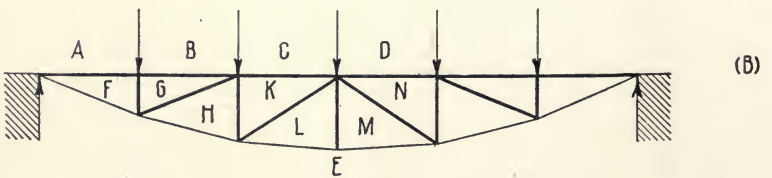

(B)

FIG. 110.

their presence, except as a means of transferring the loads from their points of application to the broken chord; the nearer the stresses in the diagonals will approach zero; and the more uniform will be the stress in the unloaded chord. Theoretically, these conditions are attained most closely when the truss is considered as a simple beam uniformly loaded, and the panel-points of the broken chord lie in a parabolic curve, since, for such a beam, the curve of bending moments is a parabola.

The bowstring truss finds frequent use for long spans in highway bridges. In an extension of this principle, both chords are curved in opposite directions, as in the *lenticular truss*. Against the economy in construction and weight of the bowstring type, there must be considered the disadvantage that, in through spans, lateral and sway bracing become impracticable as the abutments are approached, owing to the curvature of the broken chord.

95. Intersections; Lattice Girders. The trusses discussed in the preceding article have each but one system of web members consisting, as in the Warren type, of diagonals only, or, as in the Howe and Pratt systems, of diagonals and verticals combined. If, Fig. 107, the truss shown in (*B*) be superposed upon (*A*), there would be obtained, as in (*c*), the Warren *double intersection* or *double system* truss. If the loads shown in both (*A*) and (*B*) were applied to (*c*), the stress in each diagonal would still be that given by (*a*) and (*b*), but that in each chord, upper or lower, would be the sum of the original stresses in the two chords which combine to form it.

If a double-intersection truss similar to (*c*) be superposed on the latter with its joints intermediate with those of (*c*), the two form the quadruple Warren truss or *lattice girder*. This principle has been employed also with the Pratt system, the Whipple or double-intersection Pratt truss being composed of two simple Pratt trusses, combined with one pair of chords.

For any multiple-system truss, either the dead- or live-load stresses may be obtained by treating each system separately, as in (a) and (b), Fig. 107, and combining the stresses of the members which coincide. In some cases, as in the double and quadruple Warren trusses, a single stress diagram may be drawn by the general method which will give the stresses due to dead load in all of the web members; in the Whipple truss, each system must be treated separately throughout.

96. Relation of Bending Moment and Chord Stress. In a truss with horizontal chords, the stress in either of the latter at any panel-point is equal to the bending moment at that section, divided by the depth of the truss.

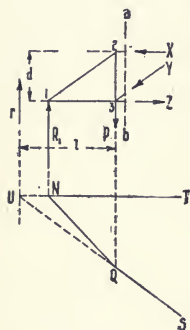

FIG. III.

Thus, let Fig. III represent a section of a Howe truss, through span, of depth d , with a part, $NQST$, of the equilibrium polygon drawn for the loads and reactions. Assume the truss to be cut on the vertical line ab to the right of, but indefinitely near, the panel-points z and 3 , so that the bending moments at the sections $a-b$ and $z-3$ will be virtually the same.

The external forces acting on the part of the truss to the left of the section $a-b$ are the load P at joint 3 and the effective reaction R_1 at the left support. To maintain equilibrium, assume the forces, X , Y , and Z ,—the same in magnitude and direction as their corresponding stresses,—as applied at the respective points of section of the severed members. For equilibrium, the algebraic sum of the moments of these external and applied forces, about an axis perpendicular to their plane of action, must be zero.

Prolong the sides, QS and NT , of the equilibrium polygon until they intersect in the point U , at a perpendicular distance l from the line of action of the force P at joint 3 . Then, by

Art. 41, the line of action of r , the resultant of R_1 and P , must pass through the point U , and the moment of r is equal to the sum of the moments of its two components. Taking moments about panel-point 3, where the lines of action of the forces Y and Z intersect,

$$\begin{aligned} X \times d &= r \times l, \\ X &= rl/d. \end{aligned}$$

But, by Art. 41, rl is the bending moment at the section 2-3, and this moment is virtually the same as that at the section $a-b$, since the two are indefinitely near.

The principle thus established is general. If the upper chord be broken (Art. 107) and the line of action of its applied force X be inclined to the horizontal, the depth d should be replaced by the perpendicular distance from the centre of moments — as panel-point 3 — to the line of action of X . Due regard should be had to the system of units employed. Thus, if the depth of the truss be taken in feet, the pole-distance of the force polygon in tons, and the bending moment in tons-feet, the chord stress will be given in tons.

It will be observed that (Art. 101 *b*), in trusses with parallel chords, the magnitude of the chord stress is the same for the chord members joining the two upper and the two lower extremities of consecutive and parallel diagonals.

97. Relation of Vertical Shear, Web Stresses, and Chord Increment. As in a simple beam, the vertical shear V , immediately to the left of any vertical section of a truss, is equal to the effective reaction, R_1 , at the left support, minus the sum of all the loads to the left of the section considered. V is thus the resultant of this reaction and these loads.

Under these conditions, for a dead load or a uniform live load, the shear diagrams, (*c*), Fig. 112, and $k''l''m''$, etc., Fig. 113, show that V is a positive maximum at the left support, decreases by steps at each panel-point, passes through

zero at the middle of the truss, and reaches a negative maximum at the right support, positive shear indicating that V acts upward, and negative shear the reverse. When the live load is not uniform, these conditions do not prevail, and the vertical shear in any panel is the algebraic sum of the shears due to dead and live loads (Art. 102); the actual shear thus found may be, as to sign, like or unlike the dead-load shear, depending on the magnitude and location of the live load.

Each panel is thus subjected to the action of vertical shear, and if, for trusses with parallel chords under any conditions of loading, the magnitude and sign of V are known, it is possible, as the succeeding articles show, to determine analytically from them the intensity and character of the stresses in the diagonals and verticals and the magnitude of the chord increment. When the upper chord is broken, as in Fig. 111, this determination becomes more complex, as the vertical components of the stresses in both the diagonals and the inclined chord members must be considered in finding the stresses which resist the vertical shear.

98. Stresses in Diagonals. It is evident that, in trusses with parallel chords, the vertical shear in any panel must be wholly resisted by the stress in the diagonal which is strained, since the latter member is the only one in the panel whose stress has a vertical component. Hence, this component must be equal in magnitude and opposite in direction to V , and, knowing V , the intensity and character of the stress in the diagonal may be found.

Thus, Fig. 112, let (A) and (B) represent, respectively, semi-trusses of the Howe and Pratt systems, under dead load or uniform live load, and let (c) be the shear diagram, which is the same for both (A) and (B). CD is the line of zero shear. Then, at the section de of (A), there is an upward shear whose magnitude is given by (c). In the force triangle (a), lay off on any scale the line $\gamma-6$ equal to V and draw the lines $6-5$ and

5-7 parallel, respectively, to the corresponding diagonal and chord member in (A). The length of the line 6-5 then represents, on the given scale, the magnitude of the stress in the diagonal; the character of the stresses, with regard to panel-point 5, is shown by the arrows, 6-5 being compressive and 5-7 tensile. The force triangle (b) gives similar results for the section *fg* in (B). In this case, as the diagonal is inclined in the other direction, the character of the stresses is reversed, that in the diagonal being tensile and that in the chord, compressive. The same reversal would occur in (a), if *V* were

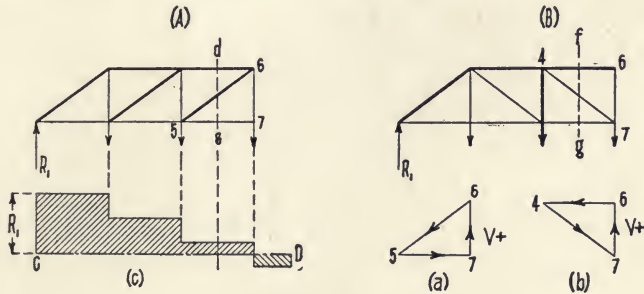

FIG. 112.

negative. The direction of the shear and stresses in passing around the triangles (a) and (b) is determined by the fact that the direction of *V* is known, and, as the three forces represent a system in equilibrium, their direction will be, by Art. 15, the same.

The reciprocal diagrams, Figs. 108 and 109, show graphically the principle established above. That it is general is clear from the diagrams for the Warren truss, Fig. 107, in which the vertical component of the stress in either of the two diagonals which intersect above or below the centre of a panel in the loaded chord is found to be equal in magnitude and opposite in direction to the vertical shear in that panel.

99. The Chord Increment. Each diagonal in a truss with parallel chords receives from one chord and delivers to the

other a horizontal stress whose intensity is equal to the horizontal component of the stress in the diagonal. This horizontal component is the *chord increment*, *i.e.*, the difference between the stresses in two consecutive members of the same chord, in proceeding from the end of the truss to the middle. The chord stress in any member of either chord is thus the sum of successive chord increments. For example, Fig. 108 (*A*), the stress fm in the lower chord member FM is the sum of the horizontal components of the stresses in the preceding diagonals, AB , CD , and EF ; and the stress in the upper chord member EA is the similar sum from the diagonals AB and CD . Hence, as the stresses in the diagonals can be ascertained by the methods of the preceding article, the magnitude of the corresponding chord increment can be determined.

It will be observed further, as to the horizontal component of a diagonal stress, that it is the difference between the stress in any two chord members which it connects, or between which it lies. Thus, Fig. 108 (*A*), the horizontal component of the stress in CD is the difference between the stresses in BK and LD , in AC and EA , and in BK and EA .

100. Stresses in Verticals. The stress in any vertical web member of a truss with parallel chords and loaded on one chord only is equal and opposed to the vertical component of the stress in the diagonal which—except in counter-braced panels and in some end and all middle panels—is the only web member to meet the vertical at a panel-point in the unloaded chord. This follows from the fact that, at such a panel-point, the only vertical forces are the stress in the vertical and the vertical component of the diagonal stress, and, for equilibrium, the two must be equal. By Art. 98, the stress in the vertical is hence equal in magnitude to the vertical shear in the panel in which the diagonal is located. In finding the stress in a vertical forming one side of a counter-braced panel (Arts. 105 *b*, 106), it is

necessary to determine which of the two adjacent diagonals is acting under the load.

Thus, Fig. 108 (*A*), the stress in the vertical *BC* which meets the diagonal *AB* at panel-point *z*, is equal in intensity to the vertical component of the stress *ab* and hence to the vertical shear in the panel to the left, or that in which the diagonal *AB* is situated. Similarly, the stress in *DE* is equal to the vertical shear in the second panel; and that in *FG*, which meets two diagonals at panel-point *o*, is the arithmetical sum of the shears in the third and fourth panels, in which these diagonals lie, the shears being added because the stresses in the two diagonals are the same in character. For the deck span (*B*), the method is the same, except that, as the panel-points in the lower chord are now considered, the stress in the vertical is equal in magnitude to the shear in the panel to the right.

For the Pratt truss, Fig. 109, the process and results are similar, with the exception that, at panel-point *z* in (*A*), two diagonals of opposite stress meet the vertical. The stress in the latter is therefore equal to the difference between the vertical components of the two diagonal stresses, or $ak - la = lk$, which is the difference between the vertical shears in the first and second panels.

In finding the stresses in vertical members of trusses with broken chords (Fig. 110), the principle of equilibrium must be applied to the vertical components of all members meeting the vertical at the panel-point selected, and the magnitude and direction of these components must be considered in determining the stress in the vertical.

101. Determination of Dead-load Stresses by the Force and Equilibrium Polygons. The stresses in a truss, due to dead load or to uniform live load, can be determined, as to magnitude, by the application of the force and equilibrium polygons to the loads and effective reactions, owing to the relations which have

been shown to exist between these stresses and the bending moments and vertical shear. This method is given in Fig. 113 as applied to a Howe truss, through span, of depth d , and under dead load.

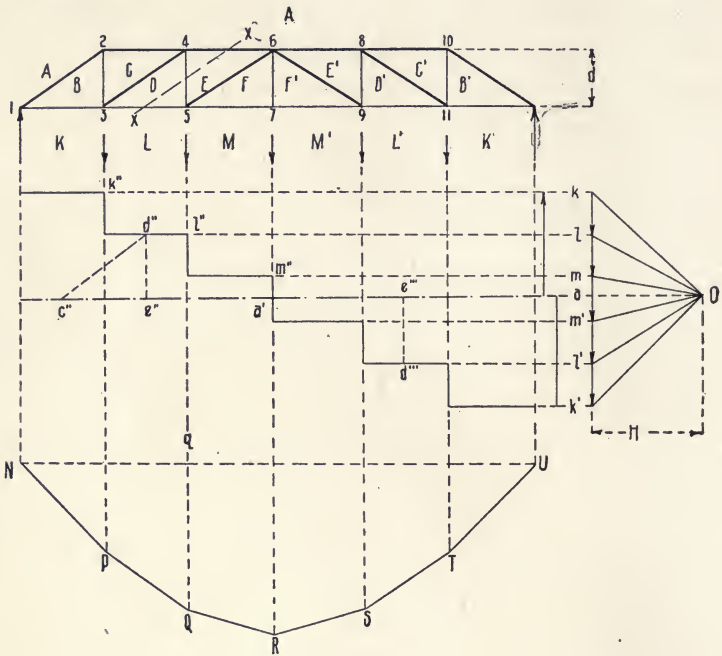

FIG. 113.

The loads and effective reactions, taken in contra-clockwise order, are plotted to any convenient scale of tons to the inch on the load-line kk' , the reactions being ak and $k'a$ and the closed force polygon, $kk'k$. Then, the pole O is located horizontally from a , at a pole-distance H equal to any desired number of tons, the distance being measured on the load-line scale. The rays $Ok, Ol, etc.$, are then drawn and the equilibrium polygon $N-R-U$ (Art. 20) is constructed.

The diagram $k'l'l'm''$, etc., for the vertical shears is drawn by projection from the lower chord of the truss and from the load-line. The median line Oa , produced, divides the diagram into

positive and negative sections, respectively, above and below this line.

(a) *Bending Moments.* By Art. 41, the bending moment at any section of the truss is equal to the product of the ordinate of the equilibrium polygon at that section by the pole-distance. Thus, at section 4-5, the bending moment is $qQ \times H$. The length of the ordinate is found in feet and is measured by the linear scale used in spacing the lines of action of the forces which pass through the vertices of the polygon, and, hence, by the scale of feet per inch employed in drawing the truss diagram. The pole-distance is measured in tons by the scale of tons per inch on which the load-line was laid out. The product, the bending moment, is thus obtained in tons-feet.

(b) *Chord Stresses.* By Art. 96, the chord stress at any section of a truss with parallel chords is equal to the bending moment at that section, divided by the depth of the truss, or $B.M./d$. If the bending moment $B.M.$ be found in tons-feet and d be taken in feet, the chord stress will be given in tons. Thus, at section 4-5, the chord stress is equal to $qQ \times H/d$, which is the stress in the members, AE and DL , as shown by Fig. 108 (a). Since the stress in any chord member is the sum of the horizontal components of the stresses in preceding diagonals, the magnitude of the stress is the same for the chord members joining the two upper and the two lower extremities of consecutive and parallel diagonals.

(c) *Stresses in Diagonals.* By Art. 98, the vertical component of the stress in any diagonal in a truss with parallel chords is equal to the vertical shear in the panel in which the diagonal is situated. Thus, $m''a'$ gives the magnitude of the vertical component of the stress in the diagonal EF . Similarly, $d''e'$ is equal to the vertical component of the stress in the diagonal CD , and $c''d''$, drawn parallel to the latter, represents, on the load-line scale, the stress in CD .

(*d*) *Stresses in Verticals.* By Art. 100, the stress in a vertical member of a truss with parallel chords is equal to the vertical component of the stress in the diagonal which meets the vertical at a panel-point in the unloaded chord, and hence is equal to the vertical shear in the panel in which that diagonal is located. Thus, the stresses in the verticals BC and DE are equal, respectively, to the shears in the panels BK and DL . The stress in FF' is equal to the sum of the shears in panels FM and $F'M'$, as explained in Art. 100.

(*e*) *Character of the Stresses.* The character of the stresses in the various members of a truss cannot be determined from the equilibrium polygon, but must be found by the other methods given previously.

Thus a truss, like a simple beam, has, for any manner of loading, its upper chord compressed and its lower chord in tension, which condition decides the character of all of the chord stresses. Again, the nature of the stresses in the diagonals is determined by the method of force triangles (Art. 98), these stresses being compressive in all of the diagonals of this truss. Finally, the stress in all of the verticals must be tensile, *i.e.*, the reverse of the vertical components of those in the diagonals meeting them at the unloaded chord.

102. Live-load Shear; Maximum Shear. As shown in Arts. 98 and 100, the stress in web members is dependent, directly or indirectly, on the vertical shear—that of any diagonal on the shear in the panel in which it is situated, and that of a vertical on the stress in the diagonal whose vertical component it resists. Thus far, only the vertical shear due to dead load has been treated. The resultant shear at any section, produced by the combination of the shears from dead and live loads, differs in intensity and sometimes in sign from the dead-load shear.

Consider first, Fig. 114 (*a*), the effect of a single-moving load P on the shear at any section, as mn , of a simple beam AB of

span s . Let the load move first from the right support toward the section. Then,

$$V = R_1 = Px/s,$$

$$R_1 - P = \frac{Px}{s} - P$$

and the shear is positive and increases as the load approaches the section. Again, let the load move to the right from the left support, being thus between the section mn and that support. Then,

$$V = R_1 - P = -P(s-x)/s,$$

and the shear is negative,

but again increases from the support to the section. It will be seen that, in each case, the shear at the section increases with the distance between it and the support from which the load moves.

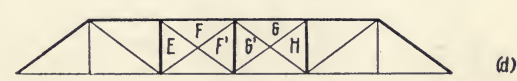
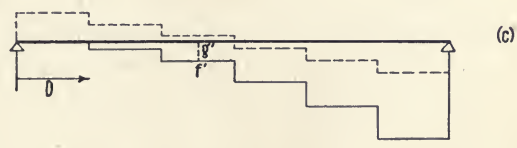
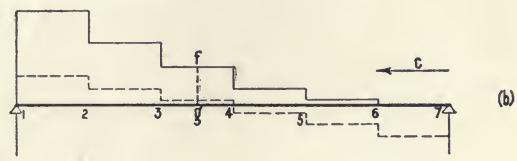
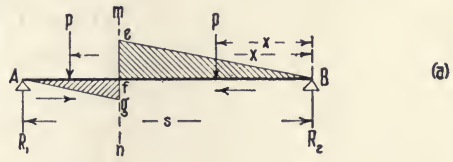

The maximum shear produced at any section by a series of such equal live loads, equally spaced, is shown in diagrams (b) and (c).

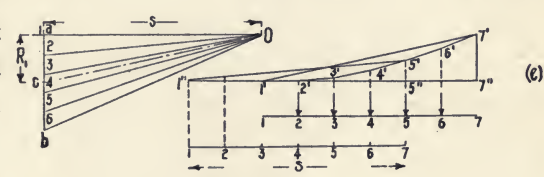

FIG. 114.

In (b), the series of loads moves from right to left; in (c), in the reverse direction. The shear diagrams for dead loads are shown by dotted lines; those for live loads, by full lines. The latter diagrams give, for any section, the shear due to equal loads at all panel-points between that section and the abutment

from which the load is moving. These are the conditions for any uniform live load covering a part of the span, as a train of cars having a constant weight per foot of length. Thus, in the panel 3-4 in (b), the live-load shear is positive and equal to fg , the loaded panel-points being 4-7; in the similar panel in (c), the similar shear is negative and equal to $f'g'$, with loads on panel-points 1-3. Since the effects produced by such a series of loads are, in general, the same as those arising from the single load P in (a), it is evident that the live-load shear in panel 3-4 passes, for these different methods of loading, from the negative shear $f'g'$ through zero to the positive shear fg which is its maximum value, since in (b) only the panel-points in the larger segment of the span are loaded.

In (b), the maximum live-load shear at any section is equal to the effective reaction R_1 at the left support; in (c), it is equal to R_1 minus all loads to the left. Figure 114 (c)* gives a ready means for obtaining graphically the value of R_1 . On the load-line ab , plot the loads 2-6; locate the pole O at a horizontal distance from a equal to the span s , and draw the rays. From the upper of the two lines indicating the truss and marked 1-7, lay off the lines of action of the loads and construct the equilibrium polygon $1'-4'-7'$, with the closing side $7'I'$. From O draw the ray Oc parallel to $7'I'$. Then, $ac = R_1$. Produce the horizontal side $1'2'$ of the polygon until it meets the vertical $7'7''$. Then, $7'7''$ is also equal to R_1 , for the triangles Oac and $1'7''7'$ are equal in all respects. This principle holds for any vertical let fall from a panel-point of the polygon on the line $2'7''$. Thus, $R_1 = 5'5''$ when the span is moved two panels to the left, as shown by the lower line. It will be observed that this process consists simply in first drawing an equilibrium polygon for the span when loaded at all of the panel-points; then, with the lines of action of the loads stationary, moving the span to the left until the required number of panel-points is loaded, and modify-

* Merriman and Jacoby, "Roofs and Bridges," Part II, p. 106, New York, 1898.

ing the original equilibrium polygon, by new closing lines, to suit these changed conditions.

Figure 115 shows the resultant shear produced by combining the shears of the dead and live loads. The dead load is indicated by full lines below the line AB representing the truss and the live load by full lines above it, except in (*a*), where it is shown by broken lines. The shear diagram is drawn beneath the load-line in each of the three cases. In (*a*) there are two such diagrams, that in full lines being for the dead load only, while the broken section lines mark the resultant shear due to this dead load combined with the uniform live load. Diagrams (*b*) and (*c*) show the resultant shear when the larger and smaller segments, respectively, of the span are loaded.

From (*a*), it will be seen that a uniform live load increases the intensity, but does not change the sign, of the shear due to dead load. Diagram (*b*) shows the maximum shear produced in the third panel, which is next to the loaded and larger segment of the span. This maximum shear is nearly twice the similar shear due to dead and uniform live loads, as in (*a*). Diagram (*c*) indicates that when a live load of this magnitude covers the smaller segment of the span, the resultant shear passes in the third panel from that shown in (*b*) through zero to its negative and minimum value, or about one-third of the numerical value given in (*b*). This tendency to a change in the sign of the resultant shear depends upon the manner of loading and upon the relation of the live and dead loads on a panel. In these diagrams, this ratio is 4 : 1, which is higher than the average in practice.

In summary, as to the live-load and resultant shears :

(*a*) A load to the right of any section of a truss produces positive shear at that section ; one to the left, negative shear. The resultant shear at the section is the algebraic sum of the shears generated by the loads to the right and left. The shear, in each case, increases as the load approaches the section.

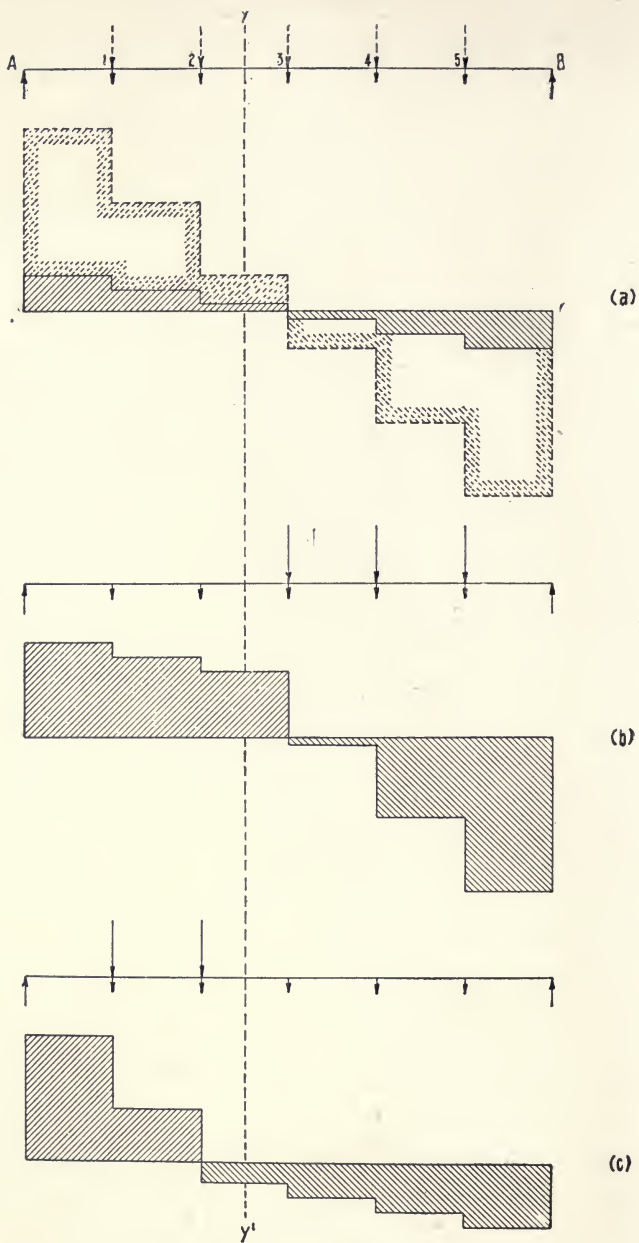

FIG. 115.

(*b*) The farther the given section is from an abutment, the greater will be the shear at that section produced by a uniform live load between the section and this abutment. Hence, the maximum absolute value of the shear at a section dividing the span into unequal segments occurs when the live load covers only the greater segment. Conversely, the minimum shear at the section exists when the live load extends over only the smaller segment of the span.

(*c*) The shear due to the dead load is positive for the left half and negative for the right half of the truss. A live load moving from the right abutment produces only positive shear in passing over the truss. The absolute value of this shear may exceed that of the negative dead-load shear before the live load reaches the middle of the truss, in which case the resultant shear will pass through zero at that point. Similarly, and with similar possibilities as to change of sign, a live load moving from the left produces negative shear, while the shear due to dead load is positive in the left half of the truss. This tendency to change of sign of the shear depends not only on the manner of loading, but also on the ratio of the live to the dead load on the panels so loaded.

103. Counter-bracing. The change of sign of the shear, referred to in section (*c*) of the preceding article, occurs in panels 3 and 4 of the Pratt truss shown in Fig. 114 (*d*). Hence, the main diagonals, EF and GH , of these panels would be subject to a reversal of stress. Since all diagonals in this truss are fitted to withstand tension only, counter-braces, FF' and GG' , are inserted. These counters are opposite in direction to the main diagonals, and, by Art. 98, a shear which would cause compression in the latter produces tension in the counters. When, therefore, the shear in a panel so changes as to tend to compress the main diagonal, the latter ceases to act and becomes a redundant member, while the load is taken, as

tension, by the counter-brace. This action is reversed when the shear again changes in sign, the counter becoming redundant. Hence, in whatever manner the load be applied, stress can exist in but one of these two crossed diagonals, and that stress is always tension. The determination of stresses in trusses having counter-braced panels is discussed in Art. 105.

104. Maximum Moments. By Art. 41, in any structure under the action of parallel forces—as a truss under dead or live loads—the bending moment at any section parallel to the lines of action of the forces is equal to the product of the corresponding ordinate y of the equilibrium polygon by the pole-distance H in the force polygon.

From Fig. 113, it will be seen, with regard to the length of the ordinate y at any section, that, for uniform live loads, any load applied to the right or left of the section increases this length. Hence, with uniform live loads, the maximum bending moment at every section occurs when the whole span is loaded, and depends upon this condition only.

When the truss is subjected to the action of a system of unequal loads not uniformly spaced,—as locomotive wheel loads,—one other condition requires consideration. The bending moment at any section is, in any case, equal to the moment of the left reaction, minus the moments of all loads to the left of that section. To increase the left reaction, and hence the moment at the section, the span should be fully loaded; but the distribution of the loads may be such that, in loading the entire span, one or more of the heaviest loads may be located so far to the left of the given section that, when their moments are deducted from that of the left reaction, the remainder may not represent the maximum moment possible at the given section with the given system of loads. Hence, generally:

With unequal live loads, unequally spaced, the maximum moment at any given section occurs when the span is, so far as is

possible, fully loaded, and one of the greatest loads is at or near the section.

Thus, Fig. 116, let it be required to find the maximum mo-

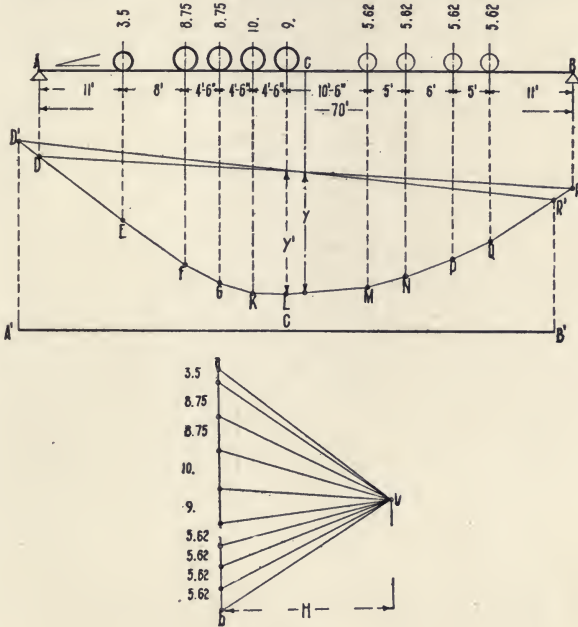

FIG. 116.

ment at the middle C of a plate girder bridge AB of 70 feet span for a single-track railway, when a 125-ton locomotive passes over the bridge. One-half of this weight will be borne by each of the two girders. In the figure, the wheel loads are given in tons (2000 pounds), and the locomotive is placed symmetrically on the span, there being a distance of 11 feet between each extreme axle and the adjacent support. The linear scale of the original drawing was 10 feet to the inch, and the load-scale was 20 tons to the inch.

The loads are laid off on the load-line ab , the pole-distance H is taken as 45 tons, the rays $Oa-Ob$ are drawn, and the corresponding equilibrium polygon $D-L-R$ is constructed. The

ordinate y under C measured 1.55 inches, which, multiplied by the linear scale, is equal to 15.5 feet; this product, multiplied by the pole-distance, gives 697.5 tons-feet as the bending moment for this position of the locomotive.

In any equilibrium polygon, the ordinate representing the maximum moment always passes through one of the vertices; that is, it corresponds with the line of action of one of the loads. One of the greatest loads, 9 tons, is 2.5 feet to the left of the section C . Therefore, keeping the lines of action of the loads stationary, assume the span to be moved that distance to the left, as shown by $A'B'$, thus bringing this load vertically over C . Prolong the side ED until it meets at D' a vertical from A' ; similarly, project B' vertically to R' on the side QR . The equilibrium polygon for the new conditions is then $D'E-L-R'$, with the closing side $R'D'$. The ordinate y' above the centre of the span $A'B'$ measured 1.62 inches, which corresponds with a bending moment of 729 tons-feet, which is the required maximum moment at the middle of the girder.

In this way, the maximum moments for any required number of sections from the centre of the span to the left can be ascertained by trial, and a curve of maximum moments plotted for the given system of loads. This curve will be symmetrical about the centre of the span. In designing a girder or truss for a railway bridge, the specified load consists of one or two locomotives followed by a train whose weight per lineal foot is given. In such cases, a section of the train should be included among the loads of sufficient length to give an original equilibrium polygon for a system of loads usually about 20 per cent longer than the span, so that the latter, when moved to ascertain the maximum moment at any section, shall not pass beyond the limits of the polygon. The section of train is considered as a uniform load, and the corresponding part of the equilibrium polygon is a parabolic curve.

The maximum bending moment produced at any section of a girder or truss by locomotive wheel loads, or by live loads in general, can be most readily ascertained by plotting a *stress-curve* for the moments as the load passes over the given section. The method of laying out this curve is described in Art. 106.

105. Determination of Live-load Stresses in Web Members by Stress Diagrams. The stresses in web members produced by a uniformly distributed live load covering the whole or a part of the span can be analyzed and, in part, determined by stress diagrams. The general method consists in drawing the stress diagram for a single live load, equal to that on one panel, applied at one of the outer panel-points in the loaded chord, as that next the left support; and, from the stresses thus found, computing those produced by a similar single load applied successively at each of the other panel-points. By this computation, the construction of a separate stress diagram for a load at each panel-point is avoided.

In Arts. 98 and 100, it was shown that the stresses in web members depend directly on the vertical shear; when but one load is applied to the truss, the vertical shear to the left of the load is equal to the left reaction and that to the right has the same magnitude as the right reaction; finally, if the load be moved from one panel-point to another, the new left reaction will be a multiple of the former one, and similarly with the right reaction although its multiple will differ. On these principles, the method of computation is based.

Since the final stress produced in a given member by the aggregate load at a number of panel-points is the algebraic sum of the stresses due to the individual loads, the total tensile and total compressive stresses and the stress due to a uniform live load can be found by the method as above; and the two former total stresses, when combined with the dead-load stress, give the range of stress in the member.

(a) *Warren truss.* Figure 117 gives the diagrams for a six-panel deck Warren truss, 96 feet span and 11.5 feet deep. The dead load per panel is 10.5 tons, one-third of which is con-

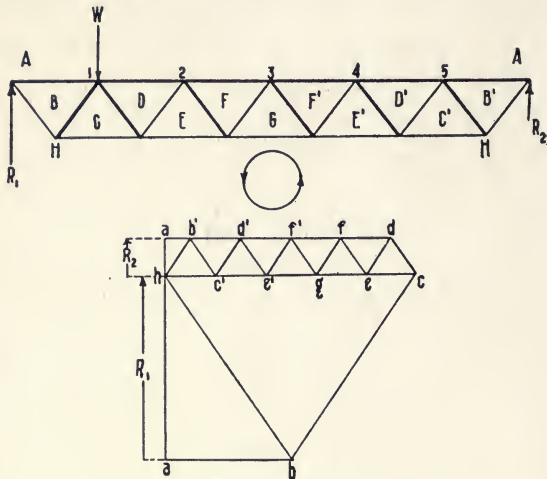

FIG. 117.

sidered as applied on the lower chord. The live load is 1800 pounds per lineal foot or 14.4 tons per panel. The diagrams represent a single live load at panel-point 1.

The stresses produced by this load and as measured from the diagram are given in tons in the second column of the following table:—

WARREN TRUSS

WEB MEMBER	LIVE LOAD AT PANEL-POINT					LIVE-LOAD STRESS			DEAD-LOAD STRESS	RANGE OF COMBINED STRESSES	
	1	2	3	4	5	+	-	UNI-FORM LOAD			
<i>HB</i> . .	+14.5	+11.6	+8.7	+5.8	+2.9	43.5	0	+43.5	+34.1	+34.1	+77.6
<i>BC</i> . .	-14.5	-11.6	-8.7	-5.8	-2.9	0	43.5	-43.5	-29.7	-29.7	-73.2
<i>CD</i> . .	-2.9	+11.6	+8.7	+5.8	+2.9	29.	2.9	+26.1	+21.2	+18.3	+50.2
<i>DE</i> . .	+2.9	-11.6	-8.7	-5.8	-2.9	2.9	29.	-26.1	-17.	-14.1	-46.
<i>EF</i> . .	-2.9	-5.8	+8.7	+5.8	+2.9	17.4	8.7	+8.7	+8.4	-0.3	+25.8
<i>FG</i> . .	+2.9	+5.8	-8.7	-5.8	-2.9	8.7	17.4	-8.7	-4.2	-21.6	+4.5

Those tabulated for loads at apexes 2, 3, 4, and 5 are computed from these stresses. Thus, when the load is at panel-point 1, $R_1 = \frac{5}{6}W$ and $R_2 = \frac{1}{6}W$; when W is moved to panel-point 2, $R_1 = \frac{4}{6}W$ and $R_2 = \frac{2}{6}W$. Therefore, in the latter case, the left reaction, the vertical shear to the left of the load, and the stresses in the diagonals to the left, are $\frac{4}{5}$ of those in the former case, while, on the right of the load, the multiple is 2. Hence, with W at panel-point 2, the stress in either HB , BC , CD , or DE is $\frac{4}{5}$ of that which existed in HB or BC when the load was at panel-point 1; similarly, the stress in any diagonal to the right of panel-point 2 is twice that which was present in any diagonal to the right of panel-point 1 when W was at the latter panel-point. With the load at panel-point 3, the multiples to left and right are $\frac{3}{5}$ and 3, respectively; similar changes take place in the multiples as the load is transferred to each succeeding panel-point.

The stress diagram is constructed for only the members in the left half of the span, as the corresponding members in the right half will have the same stresses. The stress is compressive in the two diagonals which meet at the loaded panel-point, and is alternately tensile and compressive in succeeding diagonals to the left and right. In any member, the stress which is produced by a uniform live load is the algebraic sum of the stresses tabulated for live loads at all of the panel-points from 1 to 5. The range of stress in any member is found by adding algebraically the dead-load stress to the total tensile and total compressive stresses.

The stresses due to dead load were obtained from a diagram similar to Fig. 107 (*b*), except that, as both chords are loaded in this case, the load-line overlaps as in Fig. 118 (*c*). Since the maximum chord stresses from the live load occur when the span is fully loaded, these stresses are found conveniently from a diagram for uniform live load similar to that for the dead load, except that the loads are applied on one chord only.

diagonals inclined in one direction; that is, with one-half of the truss having main diagonals only and the other half counter-ties. The substitution of the latter for a main diagonal of opposite inclination does not change the magnitude of the diagonal stress in a given panel; it simply alters its character from compressive to tensile.

In Fig. 118, the truss diagram and stress diagram (*a*) show the magnitude and character of the stresses produced by a single live load at panel-point 1; diagram (*b*) gives the stresses due to a single load at panel-point 4. The stresses from loads at the succeeding panel-points, as computed by the method of multiples employed with the Warren truss, are given in tons in the first of the two tables which follow. This computation could be made wholly from diagram (*a*), with one exception. As shown by diagram (*a*) and by Fig. 109, the stress in the end

PRATT TRUSS: ALL DIAGONALS INCLINED IN THE SAME DIRECTION

MEMBER	LIVE LOAD AT PANEL-POINT				LIVE-LOAD STRESS			DEAD-LOAD STRESS	RANGE OF COMBINED STRESSES	
	1	2	3	4	+	-	UNIFORM LOAD			
END POSTS										
<i>AB</i> ..	-27.5	-20.7	-13.8	-6.9	0	68.9	-68.9	-30.	-30.	-98.9
<i>KA</i> ..	-6.9	-13.8	-20.7	-27.5	0	68.9	-68.9	-30.	-30.	-98.9
DIAGONALS, MAIN AND COUNTER										
<i>CD</i> ..	-6.9	+20.7	+13.8	+6.9	41.4	6.9	+34.5	+15.	+8.1	+56.4
<i>EF</i> ..	-6.9	-13.8	+13.8	+6.9	20.7	20.7	0	0	-20.7	+20.7
<i>GH</i> ..	-6.9	-13.8	-20.7	+6.9	6.9	41.4	-34.5	-15.	-8.1	-56.4
VERTICALS										
<i>BC</i> ..	+25.	0	0	0	25.	0	+25.	+7.	+7.	+32.
<i>DE</i> ..	+5.	+10.	-10.	-5.	15.	15.	0	-3.5	-18.5	+11.5
<i>FG</i> ..	+5.	+10.	+15.	-5.	30.	5.	+25.	+7.	+2.	+37.
<i>HK</i> ..	+5.	+10.	+15.	+20.	50.	0	+50.	+17.5	+17.5	+67.5

vertical BC is equal to the load at panel-point 1; if there be no load at that panel-point, as in (*b*), the live-load stress in this member is always zero. This is due to the fact that, when the only loads are at or to the right of panel-point 2, the vertical shears in the first and second panels are the same, and, as the diagonal CD and the end post AB have stresses opposite in character, the vertical components of these stresses neutralize each other at panel-point 2, so that there can be no stress in BC . It will be seen that (Arts. 98, 100, 102) the stress due to any single live load is tensile in the diagonals to the left of the load and compressive in those to the right, while, on the contrary, compression is produced in verticals to the left and tension in those at, and to the right of, the loaded panel-point.

Diagram (*c*) gives the dead-load stresses; this diagram is also constructed on the assumption that all diagonals are inclined in the same way. There is no dead-load stress in the member EF , since the vertical shear is zero in the middle panel. The stresses due to a uniform live load and the range of stresses are found as before.

The first table is of service only in analyzing the stresses in the members when the diagonals are arranged as in the upper truss diagram, Fig. 118. This analysis makes it possible, however, to deduce the stresses which will exist when the members are assembled as in diagram (*d*), so that no diagonal, main or counter, shall be in compression under dead load or combined dead and live loads, the diagonals of this truss being built to withstand tension only. These final stresses are given in the table on p. 213, the dead-load stresses being those which conform with diagram (*d*).

Referring to the first table, it will be seen that it gives the final stresses in the end posts and also in the main diagonal CD , since the range of the latter should lie wholly in tension and that of the end posts in compression. The counter GH , however, in the panel corresponding with CD , is in compression

and must be replaced by the main tie GH' , whose stresses will be the same as those in CD but will occur in inverse order. In

PRATT TRUSS: FINAL STRESSES

MEMBER	LIVE LOAD AT PANEL-POINT				LIVE-LOAD STRESSES			DEAD-LOAD STRESS	RANGE OF COMBINED STRESSES	
	1	2	3	4	+	-	UNIFORM LOAD			
END POSTS										
AB . . .	-27.5	-20.7	-13.8	-6.9	0	68.9	-68.9	-30.	-30.	-98.9
KA . . .	-6.9	-13.8	-20.7	-27.5	0	68.9	-68.9	-30.	-30.	-98.9
DIAGONALS, MAIN AND COUNTER										
CD . . .	-6.9	+20.7	+13.8	+6.9	41.4	6.9	+34.5	+15.	+8.1	+56.4
EE' . . .	+6.9	+13.8	0	0	20.7	0	0	0	0	+20.7
EF . . .	0	0	+13.8	+6.9	20.7	0	0	0	0	+20.7
GH' . . .	+6.9	+13.8	+20.7	-6.9	41.4	6.9	+34.5	+15.	+8.1	+56.4
VERTICALS										
BC . . .	+25.	0	0	0	25.	0	+25.	+7.	+7.	+32.
DE . . .	0	0	-10.	-5.	0	15.	0	-3.5	-3.5	-18.5
FG . . .	-5.	-10.	0	0	0	15.	0	-3.5	-3.5	-18.5
$H'K=HK$	0	0	0	+25.	25.	0	+25.	+7.	+7.	+32.

the middle panel, the vertical shear is zero under dead load or uniform live load and hence the stress in the diagonal EF is also zero. Further, the data show that this diagonal is subjected to reversal of stress; therefore, the counter EE' should be fitted in addition, as in (a), and will then take the stress, which in it will be tensile, when one or both of the panel-points 1 and 2 are loaded, while the tie EF will be strained by the loads at panel-points 3 and 4, neither diagonal being under stress with other locations of the load.

With regard to the verticals: the essential condition for the adoption of any of the stresses in the first table as final is that

the diagonals, main or counter, which transmitted them shall be working also when the final stresses are produced. This condition holds for the vertical BC , whose stresses are governed by the position of the load and by the members AB and CD which remain unchanged. The stresses given for the corresponding vertical HK , finally $H'K$, are, however, affected by the fact that the counter GH has been replaced by the main tie GH' , the true stresses of which, as given in the final table, are evidently those of BC in reverse order.

The insertion of the tie EE' in the middle panel affects the tentative stresses given for the vertical DE with a load at panel-point 1 or 2, since EE' is then working in place of EF ; with a load at panel-point 3 or 4, EF is in action as originally, and the stresses tabulated are final. The true stress in DE for a load at panel-point 1 or 2 may be determined from the principle that, when a main tie, as CD , is working on one side of the vertical and a counter-tie, as EE' , is acting on the other, the live-load stress in the vertical is zero. Thus, the live load per panel is, in this case, 25 tons. With this load at panel-point 1, the vertical shear in the second and third panels is 5 tons, which is the vertical component of the stress in CD and also of that in EE' . The stress in the latter is tensile and in the former compressive. Hence, at panel-point 2, where the lines of action of these stresses meet, these two components neutralize each other, and the stress in DE is zero. Similarly, with a load at panel-point 2, the shear in the second panel is 15 tons and that in the third is 10 tons, and the stresses in CD and EE' are both tensile. There are then vertical upward components of 10 and 15 tons and a downward load of 25 tons acting at panel-point 2. Hence, again, the stress in DE is zero.

As to the vertical FG , it will be seen that the stresses tabulated for it will not serve for the changed conditions produced by the insertion of the tie EE' and the substitution of the main diagonal GH' for the counter GH . The true stresses are mani-

festly those of *DE* in inverse order. In both of the verticals *DE* and *FG*, the stress due to uniform live load is zero and not the algebraic sum of the individual stresses tabulated. This may be shown analytically by the method employed in computing the stresses in *DE*.

As with the Warren truss, the maximum chord stresses due to live load are found from the stress diagram for a uniform live load.

106. Determination of Live-load Stresses due to Locomotive Wheel Loads. The graphic analysis of the live-load stresses

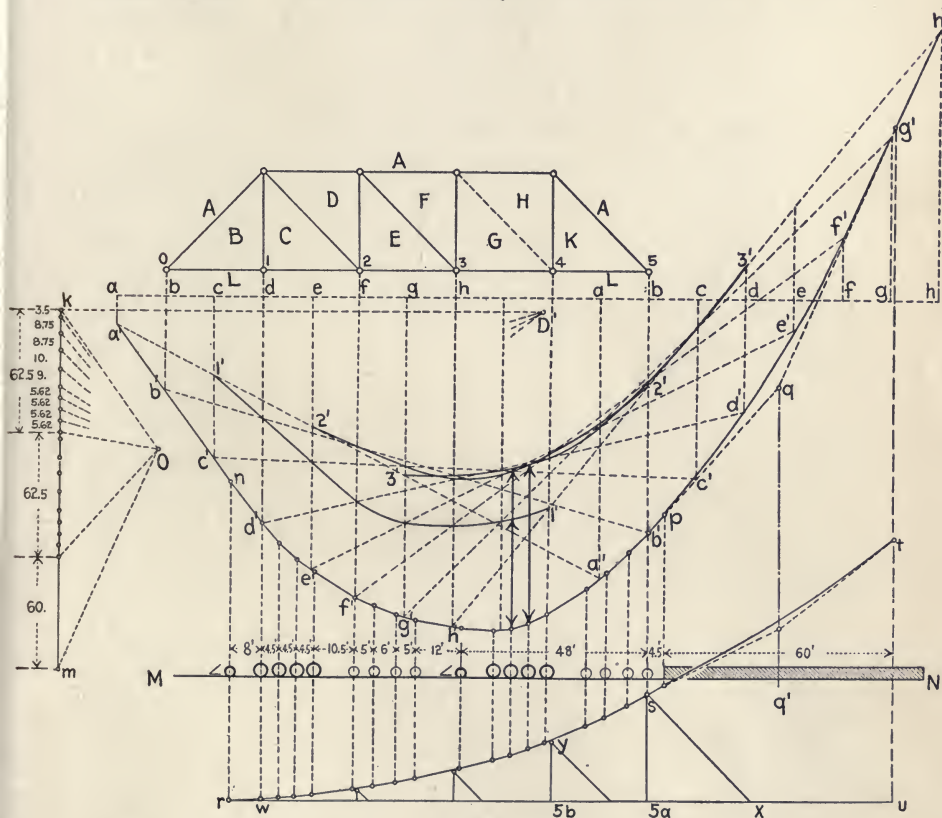

FIG. 119.

resulting from a series of unequal and unequally spaced concentrated loads, such as are applied when a locomotive crosses a bridge, can only be made by the use of the force and equilibrium polygons.

Thus, Fig. 119, consider the Pratt truss, through span, for a single-track railway bridge. The length of the truss, from centre to centre of end pins, is 125 feet; number of panels, five; depth, from centre to centre of chords, 26 feet. The assumed live load for the bridge is two 125-ton locomotives, coupled, followed by a train weighing 4000 pounds per lineal foot. One-half of this load is carried by each of the two trusses forming the sides of the bridge. The amounts and spacing of the wheel loads aggregating 62.5 tons, or half of the weight of each locomotive, are as given in Art. 104 and Fig. 116; the train weight is one ton per lineal foot of truss. The linear scale used for the truss diagram and the equilibrium polygon should not be over 10 feet to an inch and the force scale for the force polygon, 20 tons (2000 pounds) per inch. For convenience, the pole-distance should be a multiple of the depth of the truss; in the polygon Okm , it is 52 feet, or twice this depth.

(a) *Chord Stresses.* Draw the truss diagram $A-L$ with its diagonals all inclined one way, and the force polygon Okm for the weights of the two locomotives and a length, say 60 feet, of train. On the horizontal line MN , lay off the same loads with the line of action of that on the first driver coinciding with the first vertical BC prolonged. Construct the equilibrium polygon $n-d'-h'$, the portion corresponding with the train weight being a parabola tangent to the side $b'p$ prolonged and to the line $h'q$ drawn parallel to the ray Om of the force polygon. The two tangents meet at the point q on the median line qq' of the train load.

Draw the horizontal line ah and drop verticals through it from the panel-points with additional verticals at the mid-

point of each panel, in order to obtain a sufficient number of intersections to plot the stress curves. At the intersections of the verticals with the line ah , lay off $a-a$, $b-b$, etc., each equal to the span; prolong the side $d'n$ to a' and the tangent qh' to h' . Vertically below aa , bb , etc., draw the corresponding closing lines $a'a'$, $b'b'$, etc. Then (Art. 104), the equilibrium polygon $a'h'a'$ corresponds with the position aa of the span, as if the latter had been moved to the left by the distance of half a panel, the loads remaining stationary. The series of such polygons, from $a'h'a'$ to $h'ph'$, therefore, represents, for half-panel intervals, the effect of the loads as they pass over the bridge from right to left.

To determine the chord stresses, the maximum bending moment must be found at panel-points 1, 2, and 3, or from the left extremity of the truss to and through the middle panel. The intersection with a closing line of the second vertical to the right of the left end of that line will be vertically under the panel-point 1 for that position of the span, and the ordinate included between this intersection and the lower boundary of the equilibrium polygon will be the measure of the bending moment at that panel-point for that position of the span. Hence, if these intersections, for all of the closing lines, be connected by a free *stress curve*, as $I'-I'$ for panel-point 1, this curve will form the upper boundary of all of the bending-moment ordinates under panel-point 1, during the passage of the loads through the distance covered by the series of equilibrium polygons. The maximum ordinate is found by measurement between the curve and the lower boundary of the polygon; it will lie on the line of action of one of the loads, being, for panel-point 1, on that of the second driver of the second locomotive; *i.e.*, when this driver passes over panel-point 1, the maximum bending moment at that point occurs. Similarly, the intersections with the closing lines of the fourth vertical to the right of the left end of each line give the stress curve

$2'-2'$ for panel-point 2; and those of the sixth vertical, the curve $3'-3'$ for panel-point 3. The maximum ordinates in the two cases are, respectively, on the lines of action of the third and second drivers of the second locomotive.

The actual length in inches of the maximum ordinate, multiplied by the linear scale, gives the length of the ordinate in feet; and the product of this length by the pole-distance (measured in tons by the force-scale) is the bending moment in tons-feet. The quotient resulting from the division of this moment by the depth of the truss in feet (Art. 96) is the required chord stress. It will be observed that the chord stress found from the bending moment at panel-point 1 is the stress in the members BL and CL , as was shown previously in Fig. 109; that the chord stress determined from the moment at point 2 is that in members AD and EL (Art. 101 *b*); and, similarly, that the stress in AF and GL is due to the moment at panel-point 3.

(*b*) *Stresses in Diagonals.* Using the method given in Art. 102, draw a new force polygon with the pole O' at the height of the beginning of the load-line and at a horizontal distance $O'k$ equal, on the linear scale, to the span. Construct the corresponding equilibrium polygon rst with ru produced to u . Then (Art. 102), if the span be so located on the line ru that it shall include a part or all of the loads, beginning with the first load to the left, the ordinate included between ru and the polygon rst above the panel-point 5 will be equal to the left reaction, when measured by the force-scale.

Thus, placing panel-point 1 at w on the line of action of the first driver, panel-point 5 falls at $5a$ and the ordinate $s-5a$ is equal to the left reaction, and therefore to the vertical shear in the first panel. The length of the diagonal sx drawn at the same angle as AB then represents, on the force-scale, the stress in the end post AB , since the vertical component of the stress in a diagonal member is equal to the vertical shear in the panel in which that diagonal is located.

While the load on the first pilot falls at r between panel-point 1 and the left support, the shear in the first panel is still equal to the left reaction since this load is transferred by the stringers of the floor-system partly to the left support and partly to panel-point 1, and it does not act at r , but at these points. As every panel-point from 1 to the right abutment is loaded, the shear in the first panel and the stress in AB are maxima for this series of loads.

The stresses in the remaining diagonals are determined similarly, with one exception. If panel-point 2 be placed at w , panel-point 5 will be located at $5 \bar{b}$, and the left reaction will be equal to the ordinate above $5 \bar{b}$; but the load at r on the first pilot now lies in the second panel, and the shear in that panel will be equal to the left reaction, minus the portion of this load which is transferred by the stringers to panel-point 1. The load is 17 feet from this point, and the panel is 25 feet long; therefore, point 1 supports $\frac{8}{25}$ of the 3.5-ton load on the pilot. Deducting this amount, or 1.12 tons, from the ordinate, the remaining vertical $y - 5 \bar{b}$ then represents the shear in the second panel. The same deduction must be made when panel-points 3 and 4 are located at w .

The shears found from the polygon rst are those produced when the segment of the span to the right of the given panel is loaded. The shears due to a load on the left may be found from the principle that in two corresponding panels, as the second and fourth, the shear caused in one panel, when the segment to the right is loaded, is equal in intensity but opposite in sign to that in the other, when the load covers the segment to the left of it.

(c) *Stresses in Verticals.* The stresses in the vertical members are, in general, equal to the vertical shear in the panel to the right as given by the polygon rst , since (Art. 100) in that panel the diagonal is located which meets the vertical at the unloaded chord. This applies to all verticals except BC which, as explained previously (Art. 94c), has always a stress equal to the load at panel-point 1.

The maximum stress in BC will be produced when the first and second panels carry the greatest possible load. This load is evidently the half-weight, 62.5 tons, of one locomotive, since that weight covers only a distance of 48 feet, while the train weight would be one ton per foot, or but 50 tons for the two panels. If the locomotive be located in the first and second panels, its weight will be divided by the floor stringers between panel-points o , 1 , and 2 , thus constituting a system of parallel forces consisting of the nine loads and the three reactions. To find the maximum reaction at panel-point 1 , construct force and equilibrium polygons for the loads and determine the centre of gravity (Art. 28) of the latter; locate panel-point 1 at this centre of gravity and ascertain the reaction at that point; finally, determine this reaction when the span is so moved as to bring the drivers successively under the panel-point, modifying the equilibrium polygon to suit these conditions. The greatest of these reactions will be the maximum possible stress in BC .

(*d*) *Results.* The results, as determined by the foregoing methods, are given in the two tables which follow, the dead-load stresses being those ascertained previously in Art. 105 *b*. In practice, the total stresses as tabulated would be increased for impact by an amount averaging about 75 per cent of that found for live load. It will be seen that, as was shown in Art. 105, the middle panel of this truss should be counter-braced, since a reversal of stress occurs in the diagonal.

CHORDS AND VERTICALS

MEMBER	STRESS DUE TO		COMBINED STRESSES
	DEAD LOAD	LIVE LOAD	
Chords: AD	-31.	-77.2	-108.2
AF	-31.	-77.2	-108.2
LB and LC	+21.	+53.9	+74.9
LE	+31.	+77.2	+108.2
Verticals: BC	+7.	+34.6	+41.6
DE	-35	-16.5	-20.
FG	+7.	-5.7	+1.3

DIAGONALS

MEMBER	STRESS DUE TO			RANGE OF COMBINED STRESSES	
	DEAD LOAD	LIVE LOAD ON			
		RIGHT	LEFT		
<i>AB</i>	-30.	-78.	0	-30.	-108.
<i>CD</i>	+15.	+45.8	-7.9	+7.1	+60.8
<i>EF</i>	0	+22.9	-22.9	-22.9	+22.9
<i>GH</i>	-15.	+7.9	-15.	-7.1	-30.

107. Trusses with Inclined Chords. In the analysis of the stresses in trusses with broken chords, recourse must be had mainly to the method of sections (Art. 82 *b*) and the force polygon. The equilibrium polygon still serves in finding the maximum moment (Art. 104) at any given panel-point; but this moment is that in a section parallel to the lines of action of the loads (Art. 41), and when it is divided by the depth of the truss (Art. 96), the quotient is the horizontal component of the stress in an inclined member of the chord, and not the actual stress. Again, while the diagram for maximum shears (Fig. 114 *e*) may be used to determine the left reaction, it does not give, as in trusses with parallel chords, the maximum stresses in web members, since the shear is now resisted both by the latter and the inclined members of the chords. When the maximum moment is employed in any given case, it should be that at the *centre of moments*, *i.e.*, the panel-point at which a diagonal and one chord member intersect.

(*a*) *Chord Stresses.* In Fig. 120 (*a*), assume that the truss is cut on the section *ab*, indefinitely near, to the left of, and parallel to, the vertical 2-5, and that the stresses in the three severed members are replaced by the external forces, S , S_1 , and S_2 . The vertical shear is, by definition, the resultant of all of the forces to the left of the section considered. Hence, the exter-

nal forces acting on the left segment of the truss will be the shear V in the second panel and the applied forces S , S_1 , and S_2 . If there were no loads to the left of the section ab , V would correspond with a force equal to the left reaction, R_1 , and acting at the left support. In this case, as the maximum chord stress

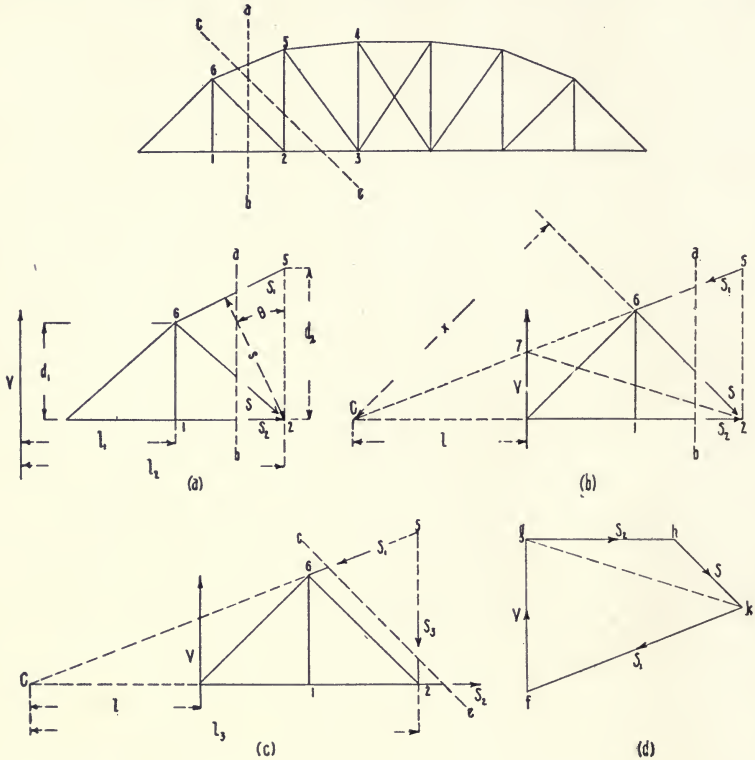

FIG. 120.

is desired, the span is fully loaded and V corresponds with the resultant r , Fig. 58, acting at the distance l from the section MN in that figure.

In Fig. 120 (a), let l_2 be the distance of the line of action of V from panel-point 2, d_2 be the depth of the truss at that point, s the perpendicular distance from that point to the member 5-6,

and θ the angle included between s and d_2 . Taking moments about the point z :

$$\begin{aligned} V \times l_2 - S_1 \times s &= 0, \\ S_1 &= Vl_2/s = Vl_2/d_2 \cos \theta. \end{aligned}$$

But as shown above, Vl_2 corresponds with rl in Fig. 58, and hence is equal to the bending moment M_2 at panel-point z . Therefore:

$$S_1 = M_2/d_2 \cos \theta.$$

Assume now that the section ab is taken at a point indefinitely near and to the right of the vertical $r-6$, where the depth of the truss is d_1 . V will then have the same magnitude, but will act at the distance l_1 . Taking moments about the point 6 :

$$\begin{aligned} V \times l_1 - S_2 \times d &= 0, \\ S_2 &= Vl_1/d_1 = M_1/d_1, \end{aligned}$$

in which M_1 is the bending moment at panel-point r .

(b) *Stresses in Diagonals.* In Fig. 120 (b), take the section ab at the middle of the second panel, and apply the external forces S , S_1 , and S_2 , as before. The maximum stress in the diagonal $z-6$ will occur when the load covers only the right and larger segment of the span. Hence, V will correspond with R_1 acting at the left support. Prolong the chord members $r-2$ and $5-6$ until they intersect at the centre of moments C . Let x be the perpendicular distance from C to the diagonal $z-6$ prolonged. Taking moments about C :

$$\begin{aligned} S \times x - V \times l &= 0, \\ S &= Vl/x. \end{aligned}$$

(c) *Stresses in Verticals.* In Fig. 120 (c), let the conditions as to the loads and as to V and C be the same as in (b). Take the diagonal section ce cutting the vertical $z-5$ and the upper and lower chords, and apply the external forces S_1 , S_2 , and S_3 . Taking moments about C :

$$\begin{aligned} S_3 \times l_3 - V \times l &= 0, \\ S_3 &= Vl/l_3. \end{aligned}$$

(*d*) *Application of Force Polygon.* In diagram (*b*), the segment of the truss is in equilibrium under the action of the forces V , S , S_1 , and S_2 . The lines of action of V and S_1 intersect at the point 7; similarly, the lines of action of S and S_2 meet at point 2. In the force polygon (*d*), resolve V on the lines fk and gk , parallel to S_1 and $7-2$, respectively; and from g and k , lay off gh , parallel to S_2 , and kh parallel to S . The polygon is then $fglkhf$, and, from it, the magnitudes and character of the stresses in the members can be determined.

108. Plate Girders. The plate girder, as shown in vertical transverse section in Fig. 121, consists essentially of a vertical

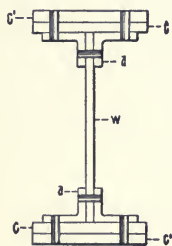

FIG. 121.

web plate, w , to the top and bottom of which horizontal angles, a , are riveted in pairs, the web and angles extending the full length of the girder. To these may be added, at top and bottom, a cover-plate, c , of partial or full length, and, if required, one or more additional plates, c' , covering the section in which the magnitude of the bending moment makes necessary the greater flange-area. These plates are all of the same width, which is that of the girder. The parts are joined by rivets passing through web and angles, and through angles and cover-plates when the latter are used. Vertical angles, riveted to the ends of the girder, transfer the load to the supports, and, to prevent buckling, additional vertical angles, or "stiffeners," are attached to the web at intervals. The effective depth of the girder may be taken as that of the web-plate. To avoid excessive deflection, this depth should be at least one-twentieth to one-sixteenth of the span.

The external forces acting on the girder are the loads and the reactions at the supports. These are transmitted directly to the web by the vertical angles riveted to the latter at the supports and under concentrated loads (if stationary), and by the rivets

of the upper or compression flange. The vertical shear produced in the web by the loads acts upon the rivets of both flanges with a leverage equal to the pitch of the rivets, and thus develops bending stress in the flanges. Since the parts are so bound together that the girder bends as a whole, bending stress, in addition to shear, acts in the web. Two methods of design are used: either (a), to assume that the web is subjected to vertical shear only and to proportion the flanges for the full bending stress; or, (b), to allow for the resistance to bending of the web, and design the flange-area for the remainder of the load.

(a) Let A be the sectional area of the angles and cover-plates forming one flange at any given point in the girder, S the mean unit working stress over that area, and h the depth of the web. Then, $A \times S$ is the total load or horizontal bending stress on the flange, and $AS \times h/2$ is the resisting moment of this stress about the neutral axis of the girder. Assuming A and S as the same for both flanges and *neglecting the bending stress in the web*, the external bending moment at the given point is equal to the resisting moment of the girder at that point, or:

$$M = 2(A \cdot S \cdot h/2) = ASh.$$

$$\text{Flange-stress} = AS = M/h.$$

$$\text{Flange-area} = A = M/hS.$$

(b) The web section is that of a rectangular beam of depth h , and breadth equal to the thickness t . Hence, its resistance to bending is $S \cdot th^2/6$. To allow for the reduced section due to vertical rows of rivet-holes, the 6 is replaced by 8. Then, *considering the resistance of the web to bending stress*:

$$M = h \cdot S(A + t \cdot h/8).$$

$$\text{Flange-stress} = AS = M/h - Sth/8.$$

$$\text{Flange-area} = A = M/Sh - th/8.$$

The flange-area, as found above, serves for the compression flange which is assumed as not weakened by the rivet-holes, since the rivets should about fill the latter. The resistance of

plates and angles in the tension flange is that of their net section, after deduction for rivet-holes. The larger gross area required in this flange is obtained by thickening one of the cover-plates, or by calculating for the tension flange and making the gross areas of both flanges the same. The maximum bending moment at any given point of the girder should be equal to the sum of the resisting moments of the angles and cover-plates.

Under stationary loads, uniform or concentrated, the girder may be treated as a simple beam in finding the shears and moments. When used in a bridge, the girders lie longitudinally and are equal in length to the span; they are connected by transverse cross-frames and diagonal lateral bracing. The analysis of the stresses in a plate girder bridge, under locomotive wheel loads, follows the same general method as that given for the Pratt truss in Art. 106, equidistant verticals being drawn which, for purposes of analysis, divide the left half of the girder into panels like those of the truss. From a similar series of equilibrium polygons, the stress curves are constructed, giving the maximum moments at these assumed panel-points; and, as with the truss, the vertical shear at the various sections is found from the polygon for maximum live-load shear. The flange stresses, as determined from the moments, are laid off as ordinates above an axis, equal in length to the girder and divided similarly, and the curve of live-load flange stress is drawn through the points thus plotted; a similar curve for the stresses due to dead load is laid out below the axis. The length of the ordinate included between the two curves at any point gives the total flange stress at that section.

PROBLEMS

84. A combination (wood and iron) Howe truss, through span, single track, railway bridge is of 77 feet span; number of panels, 7; depth, 25 feet; weight of bridge, 130,300 pounds; train-load, 4000 pounds per lineal foot. Find the maximum stresses in the members, considering the dead load as applied wholly on the loaded chord.

85. Let the double-intersection, deck Warren truss, Fig. 107 (*C*), have a span of 72 feet and a depth of 10 feet. The dead load per truss is 450 pounds per lineal foot and the uniform live load is 2000 pounds per lineal foot. Find the maximum stresses in the members, considering the dead load as applied wholly on the loaded chord.

86. Let Fig. 110 (*A*) represent the bowstring truss of a highway bridge of 45 feet span, 20 feet width in the clear, and 6 feet deep in the middle. Find dead load by approximate formula, and consider it as applied wholly on the loaded chord. Assume a maximum live load of 100 pounds per square foot of floor surface. Determine the maximum stresses in the members.

87. A single-track, deck, plate girder bridge is of 70 feet span; effective depth, 6.5 feet. A 125-ton locomotive, followed by a train weighing 4000 pounds per lineal foot, passes over the bridge. The locomotive wheel loads are those given in Art. 106. Neglecting dead load, find the maximum flange stresses and vertical shears at sections 5 feet apart from the middle to the left support.

88. Show that, as a uniform live load crosses a bridge, the curve of shears for the head of the load is a parabola.

89. In Fig. 113, assume a concentrated load as moving to the left from panel-point 5 to panel-point 3. Find the position of the load which will cause the maximum stress in the diagonal *CD*.

90. Show that the live load will produce the maximum shear in a given panel when :

$$P = W/n,$$

in which *P* is the live load on the panel, *W* is the total live load on the truss, and *n* is the number of panels.

91. Show that the live load will produce the maximum moment at any given section of the truss when :

$$P' = Wl'/l,$$

in which *W* is the total load on the truss, *P'* is the load to the left of the section, *l* is the span, and *l'* is the distance from the section to the left support.

92. Let *w* = dead load per panel and *w'* = 5 *w* = uniform live load per panel on a 7-panel truss. Which panel or panels require counter-bracing ?

93. What is the minimum stress in a vertical forming one side of a counter-braced panel in a Howe truss ? In a Pratt truss ? What position of the live load produces this minimum stress in a vertical not thus adjacent to a counter-braced panel in these trusses ?

CHAPTER X

THE GRAPHICS OF FRICTION

IN any machine, the force applied to the first or driving member acts — through the transfer of motion from one member to another of the train of mechanism — either wholly in overcoming the internal resistance of the machine and that met by the final or driven member in doing useful work, or partly in this and partly in storing energy in an intervening member, as a fly-wheel. Since energy thus absorbed in acceleration will be fully restored in retardation, this action may be disregarded and uniform motion assumed.

Under the latter assumption, the *total work* of any machine, in a given time, is that done by the driving force in the distance through which it acts; the *useful work* is that expended in overcoming the resistance met by the final or driven member in the space through which it moves during this period; and the difference between the two is the *lost work*, or that which is required to overcome the resistance to motion of the mechanism itself.

This loss of work is due to three causes: the resistance of the medium, as the air, in which the machine operates; the friction from the relative motion of surfaces of the mechanism in contact and under pressure; and, in machines not properly constructed, the work absorbed in the permanent distortion of their parts, owing to the lack of strength or elasticity of the latter. The first of these losses is negligible and the last is never present in well-designed machines, so that friction may be considered as virtually the sole cause of lost work in mechan-

ism. In the articles which follow, its action in reducing the efficiency of machine elements will be investigated.

109. Efficiency of Mechanism. The *efficiency of a machine* is the ratio between its useful and total work. Thus, if P be the driving force and s the space through which it acts in a given time, the total work will be $P \times s$. If, during this period, U be the resistance of the final or driven member in doing useful work and s' be the distance through which this resistance is overcome, the useful work, under the assumption of uniform motion as above, will be $U \times s'$. Then, the efficiency :

$$E = U \cdot s' / P \cdot s,$$

a ratio which is always less than unity, while, if the mechanism were frictionless, $U \cdot s'$ would be equal to $P \cdot s$ and E would be unity. This ratio, being expressed in quantities of work, gives the average efficiency during the period considered.

Again, the efficiency may be expressed as the ratio between the magnitudes of the useful and the total amounts of effort exerted at a given instant, and for the relative positions of the parts at that instant. Thus, if P represent the total force as before, and P_0 be the force, acting through the same space as P , which would be required to do the useful work, then :

$$E = P_0 \cdot s / P \cdot s = P_0 / P,$$

which is the efficiency at the given instant.

In determining the efficiency of a machine which is composed, as is usual, of a number of elementary mechanisms, the principle to be observed is that the force required to overcome the resistance of the final elementary mechanism constitutes the resistance of the elementary mechanism immediately preceding, so that the efficiency of the whole machine is the product of the efficiencies of all its elementary mechanisms.

The *counter-efficiency*, as used by Rankine, is the reciprocal of

the efficiency, and hence, as the relation between the total and the useful work or effort, gives the ratio in which the former must exceed the latter.

110. Friction. The sliding friction of solids is the resistance to relative motion when their surfaces are in contact and under pressure. If the parts thus in contact were perfectly smooth and hard, friction would not exist, since it is caused by the interlocking of surfaces which, although they may appear to be smooth, are in reality minutely rough and uneven. Hence, to secure motion, these projections must be disengaged and overridden, an operation requiring the expenditure of mechanical work. The investigation of friction is complicated by other factors which may enter into the total resistance to motion, such as adhesion at low pressures and with lubricated surfaces, the viscosity of the lubricant, and abrasion at unduly high pressures in machinery. The total resistance, when any of these factors enter, is not purely frictional.

Sliding friction is the friction of plane surfaces; the friction of screw-threads and journals is a modified form of this action. *Rolling friction* (Art. 125) is the friction of a curved body, as a sphere or cylinder, when rolled on a plane surface or one of different curvature. The force of friction, in this case, acts along the common tangent of the two surfaces. Theoretically, contact occurs only on a point or a line; practically, as the materials used in engineering constructions are all more or less elastic, there is a surface of contact. Hence, rolling friction is identical in cause with sliding friction, but the resistance due to it is so small that it is usually negligible in machine design.

Friction has been further differentiated as the *friction of rest* and the *friction of motion*. The former of these is evidently the greater of the two, since, while at rest, the harder body has opportunity to indent the softer and embed itself therein. As the slightest jar will nullify this action, and as, in machinery,

the resistances of surfaces often moving at high velocity constitute virtually all of the problems in friction requiring investigation, only the friction of motion will be considered herein, except with regard to belt-gearing.

111. Laws of Sliding Friction. These laws are far from being well established. The force of friction which opposes the relative motion of two surfaces acts along their common tangent, and if the normal pressure and the velocity be low and the surfaces be dry or but slightly lubricated, the force of friction is, in general, taken as :

$$F = fN,$$

in which N is the total pressure normal to the surfaces in contact and f is the *coefficient of friction* which is assumed to have a constant value for the same materials and conditions of the surfaces. This assumption implies that the force of friction is independent of the velocity of the surfaces, the area of contact, and the pressure per square inch.

Except under the limitations noted, these assumptions represent in no sense the conditions of practice. Kennedy * says :

“Engineers, however, have seldom to do with unlubricated rubbing surfaces, and they have to deal with surfaces moving often with very high velocities and under very great and frequently varying pressures. Under these conditions, the ‘laws’ of friction, as they have just been stated, not only do not hold exactly true, but fail even to represent approximately the more complex phenomena with which engineers have to deal. At many speeds and loads which are of daily occurrence in machinery, velocity and intensity of pressure (pressure per unit of surface) have an enormous effect on the friction, and not only these but the temperature of the surfaces and the nature of the lubricant. The nature of the rubbing contact also, whether continuously in one sense, or continually reversed, whether the surfaces be flat as in a guide, or cylindrical as in a bearing, whether contact exists throughout a surface or only along a line, greatly affect the friction. The actual materials of which the surfaces consist forms only one out of an immense number of conditions

* “Mechanics of Machinery,” London, 1898, p. 569.

which determine friction under a given load. . . . We may, therefore, write $F/N=f$, the friction-factor (or coefficient of friction), so that we still have :

$$F = fN,$$

but with the condition that f is a quantity whose value has to be separately considered for each set of conditions."

112. Coefficient of Friction. While the value of the coefficient of friction f requires independent determination for every alteration in the conditions governing the friction of surfaces in contact and moving relatively, it still may be taken as a factor by which the total normal pressure N on the contact-surfaces must be multiplied to obtain the force of friction F .

In Fig. 122, let AB and AC represent planes hinged at A and supporting a body D of weight W . Keeping AC horizontal, let

B be raised until the limiting condition for equilibrium of the body D is attained, *i.e.*, until, with any further elevation of B , the body will slide downward. Let the angle $BAC = \phi$. Resolve W into components DE and EG , perpendicular and parallel, respectively, to the surface AB . The force of friction F is produced by the

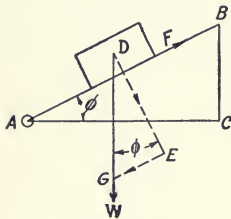

FIG. 122.

former of these components which is the total normal pressure N on the contact-surfaces, and is equal in magnitude and opposed in direction to the latter. Hence :

$$F = fW \cos \phi = W \sin \phi \text{ and } f = \tan \phi.$$

The angle ϕ is known as the *friction angle* or *angle of repose*; as has been stated, its size differs with every change in the conditions governing the friction of the surfaces under consideration. General, but arbitrary values of the coefficient f , which may be assumed in graphical problems are: for sliding friction of moderately lubricated surfaces, 0.16; for screw- and tooth-friction, 0.1; for chain-friction, 0.2.

113. Friction of Horizontal Plane Surfaces; Cone of Resistance.

Let Fig. 123 represent a body of weight W resting on a horizontal plane AB . While no force acts but that of gravity, the body will be held in equilibrium by the weight W , acting from the centre of gravity O , and by the reaction $R = N$ of the plane AB . This reaction is equal to and opposed to W , has the same line of action, is normal to the contact-surfaces, and is the resultant of the infinite number of infinitely small reactions from that surface.

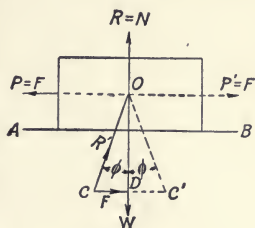

FIG. 123.

Assume now a force $P = F$ as applied. The magnitude of this force is such that, with any increase, it will cause motion to the left, the limiting condition of equilibrium having been reached; it therefore is opposed by the full force of friction F . The body is now in equilibrium under the action of the forces, W , R , P , and F . The resultant of R and F is the *virtual reaction*, $R' = CO$, making the angle of friction, ϕ , with the line of action of R . Since equilibrium prevails, W , R' , and P meet at a common point O . For motion to the right, similar but reversed conditions exist, as shown by dotted lines. In either case, the supporting plane AB , the normal reaction R , and the force of friction F may be replaced by the virtual reaction R' , making the angle of friction with the normal to the contact-surfaces, and in such a direction that its component parallel to those surfaces will oppose their relative motion.

It will be seen that the limiting condition for equilibrium, with regard to motion in any direction, is that the virtual reaction shall lie on the surface of the cone described by the revolution of the triangle OCD about the normal OD . This is the *cone of resistance* or the *friction-cone*. When the force P is less than F , R' falls within the surface of the cone and there will be no motion; when P is greater than F , R' lies beyond the cone, and motion ensues.

114. Wedge Friction. With a wedge, the load is supported on a plane slightly inclined to the horizontal. Taking the simplest case, let Fig. 124 represent a block *A* of weight *W* as raised in the guide-way *B* by the key *C*, resting on the horizontal support *D*, and driven to the right by the force *P*.

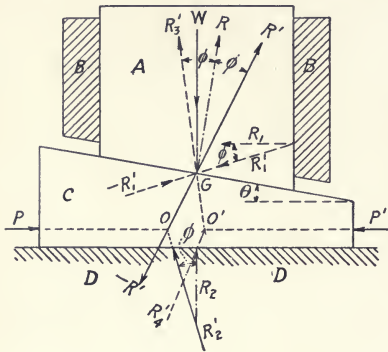

FIG. 124.

If the mechanism were frictionless, the block, when just about to move, would be acted on by the weight *W*, the reaction *R* normal to the surface of the key, and the reaction *R*₁ normal to the contact-surface of the guide. Considering friction, these reactions become, respectively, *R'* and *R*₁', inclined from the normals by the angle of friction in such a direction that the force of friction shall oppose the upward movement of the block on the key and in the guide. As to the forces, *W*, *R'*, and *R*₁', the magnitude and direction of the first are known and the directions of the two latter. Their points of application are not known, but this is immaterial in this case, the only requirement being that, as the block is in equilibrium, the lines of action of the three forces shall meet at a common point.

In the figure, this point is assumed to be *G*. In the force polygon, Fig. 124 *a*, the vertical line *ab* is made equal to *W* on the given scale, and *bc* and *ca*, drawn parallel to *R'* and *R*₁', respectively,

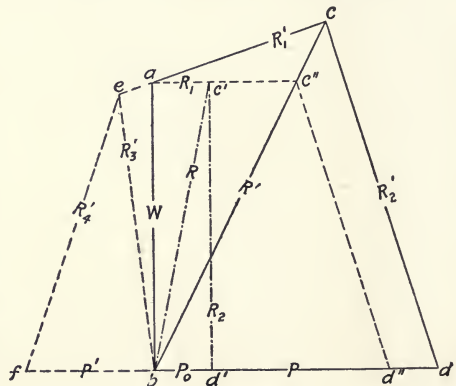

FIG. 124 *a*.

represent the magnitudes of these reactions. Similarly, bc' and $c'a$ show these magnitudes, when friction is disregarded.

The key, when on the point of moving to the right, is in equilibrium under the action of the force P , the reaction $-R'$ equal to and opposed to R' , and the reaction R_2' , inclined by the angle of friction to the normal, R_2 , to the contact-surface of the support D . The point of application of the reaction R_2' is determined by the consideration that its line of action must pass through the intersection O of the lines of action of P and R' . In the force polygon, bd and dc , drawn parallel to P and R_2' , respectively, represent the magnitudes of this force and reaction, while $bd' = P_0$ and $d'c'$ give these magnitudes when friction is neglected. The efficiency of the key is then :

$$E = P_0/P = bd'/bd.$$

Now, assume the force P to be removed and an opposite force P' applied, of such magnitude that the key will be just on the point of backing out. The block A will then be acted on by the weight W , the reaction R_3' , making the angle of friction with R and inclined in the opposite direction from R' , and by the reaction $-R_1'$ acting from some point on the contact-surface of the left-hand side of the guide B . Similarly, the key will be in equilibrium under the action of the force P' , the reaction $-R_3'$, and the reaction R_4' of the support D , the lines of action of these three forces meeting at the point O' . The corresponding sides of the force polygon are drawn parallel to the lines of action of the forces, as before, and $be = R_3'$, $ea = -R_1'$, $fe = R_4'$, and $bf = P'$. Since P' and W both act to back out the key, the efficiency is negative and is :

$$E = P'/P_0 = -bf/bd',$$

in which, as the figure shows, the frictionless force P_0 has the same value as before.

If, in the force polygon, the horizontal side ac' be prolonged

until it intersects the side bc , and the side $c'd''$ be drawn parallel to cd , the friction of the block A on the guide B will be disregarded and $P = bd''$, which is the horizontal force required to bring the block of weight W to the point of starting up the incline of the key or wedge. Analytically, if θ be the angle of taper of the key, this force bd'' is:

$$P = W[\tan(\phi + \theta) + \tan \phi],$$

and the corresponding backing force is:

$$P' = W[\tan(\phi - \theta) + \tan \phi].$$

If the key be double, *i.e.*, the top and bottom having the same angle of taper θ :

$$P = 2 W \tan(\phi + \theta),$$

$$P' = 2 W \tan(\phi - \theta),$$

which equations, as before, neglect the friction of the guide B .

115. Friction of Screw-threads. The threads of a bolt and nut are, in their frictional action, essentially the same as the block and the single-tapered key which were discussed in Art. 114, when the friction of the guide B and of the support for the nut are excluded. The load W is borne by the bolt, whose thread thus corresponds with the contact surface of the block A , Fig. 124; and the nut-thread, like the similar surface of the key C , raises the bolt-thread with its load, the nut being supported by a bearing surface similar to that of D .

The pressure on these threads is assumed as concentrated on the mean helix (Art. 117) or the circumference of the mean thread-diameter d , of pitch-angle α , as in Fig. 125. Each element of the thread-surface is regarded as sustaining an equal elementary portion of the total axial load or stress W , on the bolt, and each element has, therefore, a frictional resistance of the same magnitude. Since the conditions for all elements are thus identical, the total thread-resistance, the axial load, and the

external turning forces on the nut may be assumed to be each equally divided and concentrated at two points, 180° apart, on the circumference of diameter d . The forces P , for lifting the load, thus form a couple whose arm is d ; and, similarly, the

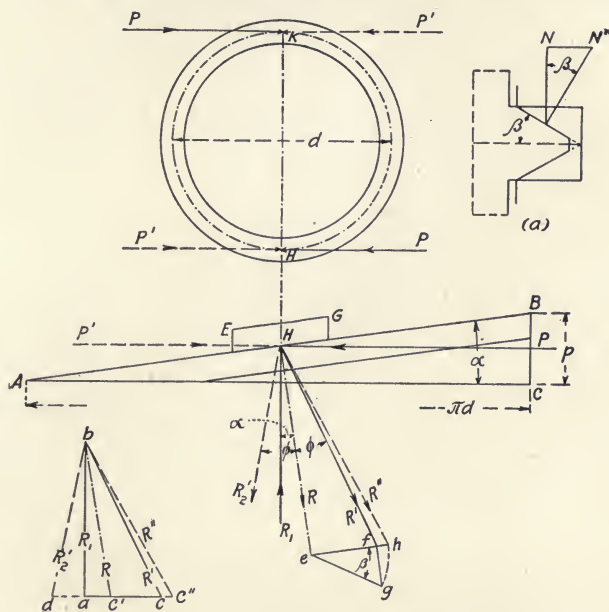

FIG. 125.

forces P' for lowering have the same arm and points of application. In Fig. 125, these points are H and K .

Square Threads. In Fig. 125, taking the nut as the turning member, let ABC be the inclined plane formed by developing one convolution of the nut-thread of the mean diameter; AB is the contact-surface of that thread and EG represents a portion of the bolt-thread. The base of the plane is πd , its height is the pitch p , and the pitch-angle is BAC . Consider the forces P or P' as applied to the nut in a plane normal to the axis and as tangent to the mean thread-circumference.

When the nut-thread is on the point of moving to the left to

raise the load, its front half, whose centre of pressure is at H , is in equilibrium under the action of one of the forces P , the reaction R' making the friction-angle with the reaction R which is normal to the contact-surface, and the reaction $R_1 = W/2$ of the nut-support, which reaction is vertical as the friction of the support is neglected. The force and the two reactions are all in the same vertical plane, which is distant $d/2$ from the axis.

In the force polygon, lay off $ab = R_1$, and draw bc , bc' , and ca parallel, respectively, to the lines of action of R' , R , and P . Then :

$$P = ca = W \tan (\phi + \alpha),$$

and, for frictionless motion :

$$P_0 = ac' = W \tan \alpha.$$

When the nut-thread is about to lower the load under the action of the force P' , the reaction at the contact-surface becomes R_2' , making the friction-angle with the normal reaction. Equilibrium then exists under the action of the force P' and the reactions R_1 and R_2' . Drawing bd parallel to the latter :

$$P' = da = W \tan (\phi - \alpha).$$

The efficiency of the screw threads in raising the load is :

$$E = P_0/P = ac'/ca = \tan \alpha / \tan (\phi + \alpha),$$

which is low, as ϕ is relatively large as compared with α . With ordinary square threads, dry or but slightly lubricated, the coefficient of friction f usually ranges between 0.1 and 0.2, giving values of ϕ of about $5^\circ 45'$ and $11^\circ 30'$, respectively. In the standard system of square threads used by William Sellers and Company, the angle α is for $\frac{1}{4}$ -inch screws and 4-inch screws about $8^\circ 45'$ and $3^\circ 15'$, respectively. These values are for power screws whose pitch is twice that of the United States Standard.

With regard to the equations and the graphic methods given above, it will be understood that, in order to eliminate all fric-

tion but that of the screw-thread, the section EG of the bolt-thread is assumed to have no lateral motion, so that it and the weight W rise or are lowered vertically, as would be the case with a bolt. Further, the force P is sufficient to raise but one-half of W , since it forms one force of the couple whose arm is d ; the lowering force P' is part of a similar couple.

Triangular Threads. In Fig. 125 *a*, let N and N' be the normal pressures on square and triangular threads, respectively. Then, $N' = N \sec \beta$, in which β is the base-angle of the triangular thread. If F and F' be the forces of friction for the two threads, we have, since $F = fN$:

$$F' = fN' = fN \sec \beta = F \sec \beta.$$

Hence, as compared with the square thread of the same pitch-angle, the friction F' of the triangular thread is $\sec \beta$ times greater.

To determine the force P in Fig. 125 for these conditions, prolong the lines of action of R and R' and, at any point, draw the line ef perpendicular to R . This line is proportional to the force F . From e draw eg making the angle β with ef ; from f drop the perpendicular fg on eg , thus determining the line eg which is proportional to the force F' . Revolve eg to eh on ef prolonged, and draw Hh which is then the virtual reaction R'' of the triangular thread. In the force polygon, lay off bc'' parallel to the line of action of R'' , and the force P will then be ac'' .

In the Sellers system, the angle $\beta = 30^\circ$ and $\sec \beta = 1.15$. The increased friction of the triangular thread reduces the efficiency of the screw, adds to the torsional stress in the body of the bolt produced by the component of the total load which is normal to the axis, and the inclination of the normal reaction develops a bursting action on the nut, which action, disregarding friction, does not exist with the square thread.

116. Pivot Friction. When the lower end of a vertical shaft,

subjected to end-thrust, is supported and guided by a step-bearing, the end of the shaft forms a *pivot journal*; the latter may be plane, conical, globular, etc.

Plane Pivots. As shown in Fig. 126, the pivot rests on a brass or steel disk, set in a casing bushed with brass; the disk

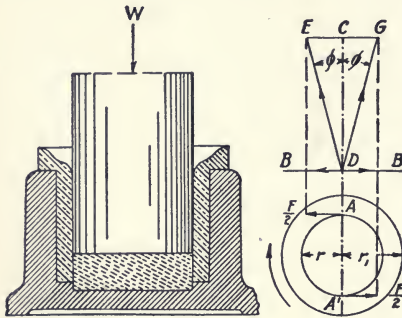

FIG. 126.

is usually slightly cup-shaped. If the disk is not fixed, but can revolve and is well lubricated, it will have relative motion with regard to the shaft, so that, owing to the reduced velocity of the disk and bearing surfaces, the friction between shaft and disk and disk and bearing will be less than if

the disk were fixed, with a consequent reduction in wear. Several such disks, one above the other, are often fitted in pivot bearings.

Let the total axial load on the shaft be W , and, as with the screw-thread, assume it to be equally divided and one half concentrated at each of the two points, A and A' , diametrically apart, on the circle of radius r described on the disk of radius r_1 . The total normal pressure on the bearing is W ; the average pressure per square inch is $W/\pi r_1^2$. The total force of friction is $F=fW$, and assuming a uniform pressure over the disk, the frictional resistance per unit of area is $fW/\pi r_1^2$. It is required to determine the relation between the radii r_1 and r , the latter being the distance from the centre to either of the points* of application, A and A' .

Consider the circumference $2\pi r$ to be an elementary ring of width dr and of area $2\pi r dr$. The total normal load or pressure on this ring is:

$$w = 2\pi r dr \times W/\pi r_1^2.$$

Multiplying w by the coefficient of friction f gives the frictional resistance of the elementary ring, and this product, multiplied by the radius r , is the moment m of this elementary resistance or force of friction :

$$wfr = m = \frac{2fW}{r_1^2} \cdot r^2 dr.$$

The integral of this expression, between the limits r_1 and zero, gives the moment of the total frictional load or force F , which is :

$$M = \frac{2fW}{r_1^2} \int_0^{r_1} r^2 dr = \frac{2}{3} fWr_1.$$

Dividing the moment by its force, $F = fW$, we have the mean radius at which the total force F acts, or :

$$M/F = 2/3 r_1 = r.$$

In the diagram, BB is the plane of the disk, $CD = 1/2 W$, and DE and DG are the virtual reactions at the points A and A' , respectively.

Conical Pivots. In this form, the end of the shaft is cone-shaped, and is supported by a bearing of similar inclination, as shown in Fig. 127.

Let θ be the half-angle of the cone, r_1 the radius of the upper end of the journal, and W the total axial load. As in Fig. 126, consider one-half of W as concentrated at each of two points, 180° apart, on an elementary strip of the conical surface of radius r and width dr . Resolve W in the directions of the two normals NN to the contact-surface at these points.

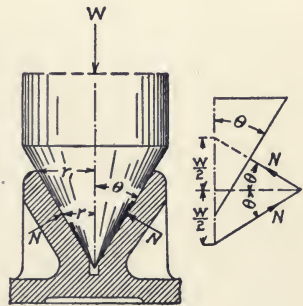

FIG. 127.

Then, $N = W/2 \sin \theta$, and the total force of friction,

$$F = 2fN = fW/\sin \theta.$$

By using the same method as with the plane pivot, the mean

radius at which the total force of friction F acts will be found again to be $2/3 r_1$. Hence, a diagram similar to that in Fig. 126 will show the forces graphically, the differences between the two cases being that the circular area of radius r_1 now represents the projected area of the conical bearing, and that each of the forces $F/2$ is now equal to $fW/2 \sin \theta$, and not to $fW/2$ as before. Under these conditions, the work expended in friction would be the same for this projected area as for the contact-surface of the bearing.

Mean Radius of Friction. For the two cases discussed, it has been shown that, theoretically, this radius is $2/3 r_1$, where r_1 is the greatest radius of the bearing; this is true also of all pivot bearings whose projected area is circular and not annular. The difference between the amounts of frictional work of the various forms of pivots lies thus, not in their radii of friction, but in the magnitudes of the respective forces of friction F .

The theoretical value of the mean radius, as above, assumes a uniform pressure per square inch and a constant value of the coefficient f for the whole surface of the bearing. Experiment shows, however, a dependence of the friction on the velocity of rubbing, and, further, as in any pivot this velocity increases directly as the distance of the surface considered from the centre, the augmented friction and wear thus produced on the outer portion of the bearing surface reduce its pressure per square inch and increase that on the inner portion. In view of these considerations, a mean radius of friction equal to one-half the greatest radius of the bearing surface of the pivot is, for types having a projected area of bearing surface of circular form, generally taken as more nearly correct than the two-thirds value deduced as above. For the plane pivot, F would then be equal to fW ; the moment of this force would be $fW \times r_1/2$; and the work of friction at n revolutions per minute would be

$$fW \times \frac{2\pi r_1}{2} \times n = \pi fWnr_1.$$

117. Collar Friction. The collar bearing is shown in Fig. 128. It has two advantages as compared with the plane pivot: as the collar is narrow radially, the velocity is more nearly uniform over its surface; and, by using a number of collars, as in the marine thrust-bearing, a much greater axial load can be carried by the shaft than the pivot bearing, with its restricted dimensions, will permit.

Let W be the total axial load on the shaft, and assume it to be equally divided and one-half concentrated at each of the two points, A and A' . The external radius of the bearing is r_1 ; its internal radius is r_2 ; and the mean radius of friction is r . The value of the latter, in relation to those of r_1 and r_2 , is to be deduced.

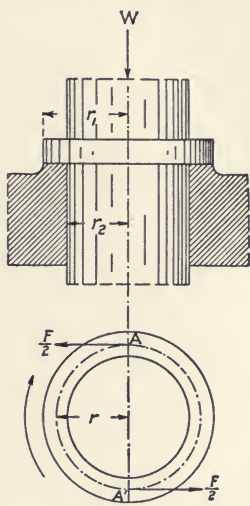

FIG. 128.

The total force of friction is $F = fW$, and, assuming a uniform pressure over the whole surface of the bearing, the frictional resistance per unit of area is $W/\pi(r_1^2 - r_2^2)$. The area of an elementary ring of radius r is $2\pi r dr$. The total load on this ring is:

$$w = 2\pi r dr \times W/\pi(r_1^2 - r_2^2).$$

The frictional resistance of this load is fw and the moment m of this resistance is:

$$fw \times r = m = fr \times 2\pi r dr \times W/\pi(r_1^2 - r_2^2).$$

The integral of this expression, between the limits r_1 and r_2 , gives the moment of the total frictional load or force F , which moment is:

$$M = \frac{2fW}{\pi(r_1^2 - r_2^2)} \int_{r_2}^{r_1} r^2 dr = \frac{2}{3} \cdot \frac{r_1^3 - r_2^3}{r_1^2 - r_2^2} \cdot fW.$$

Dividing this moment by the force $F = fW$, the mean radius of friction is :

$$r = \frac{2}{3} \cdot \frac{r_1^3 - r_2^3}{r_1^2 - r_2^2}.$$

If the internal diameter of the bearing be 10 inches and its width 2 inches, r_1 is 7", r_2 , 5", and, from the last formula, r will be found to be 6 inches, or the mean of r_1 and r_2 . This is the justification for considering the total load on a bolt as concentrated on the mean helix, in computing the friction of screw threads (Art. 115), since, if the pitch-angle be made equal to zero, the square thread becomes a collar.

118. Journal Friction. A shaft-journal fits its bearing more or less loosely for two reasons: the bearing is bored a little larger in order to make a working fit; and, to prevent "seizing" when hot, the sides near the joint with the cap are made free, so that, in each semicircle, there is an arc of contact which is considerably less than 180° . The wear in service increases this looseness, and the journal eventually rotates in a bearing of different and greater curvature.

When the shaft is at rest, the journal lies at the bottom of the bearing, the only forces then acting on it being the weight of the shaft and the equal and opposite reaction of the bearing, which have the same line of action. It would remain in this position when the shaft revolves, if the contact-surfaces were without friction; but the latter causes the journal to roll up the side of the bearing in a direction opposite to that of rotation. This action is similar to that of a car-wheel moving up an inclined section of track, except that, in this case, the path is curved, so that the angle of inclination changes continually.

The journal thus ascends the bearing until, owing to the opposing action of the weight, it begins to slide backward. At any instant, its condition is hence one of momentary equilibrium under the action of the turning force, the weight, the reaction

from the bearing, and the friction. This position will be maintained so long as the coefficient of friction remains unchanged; but, when the latter alters, through variations in shaft-velocity or in the character of the contact-surfaces, the journal rises or falls, as the case may be.

The conditions are thus complex, and the resistance to rotation of a shaft in a fairly free bearing cannot be considered as purely frictional. The latter action is much more nearly reached in the bearings of small axles and of the pins in link connections, where closer fits are permissible. The graphical analysis employed in such cases is shown in Fig. 129. The principles of this method were first established by Rankine,* and later developed by Hermann and others.

Let A be a cylindrical journal at rest in the bearing B ; the forces acting are the weight or other vertical pressure $W = CD$, and an equal and opposite reaction from the bearing at the point G . Now, let there be applied a turning force P , normal to a radius, and of such magnitude that the limiting condition of equilibrium is reached, the frictional resistance is overcome, and the journal is on the point of beginning clockwise rotation. The forces acting are then W, P , and the reaction R' from the bearing, whose line of action is yet to be determined.

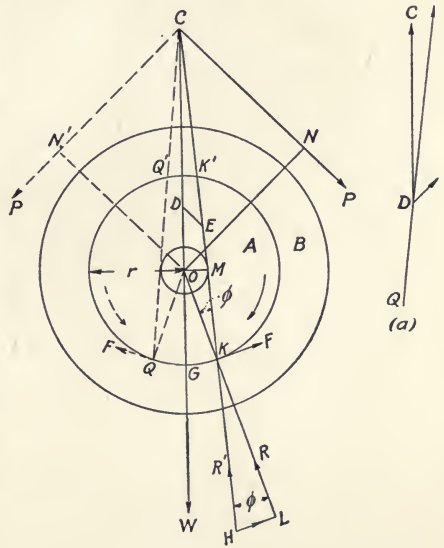

FIG. 129.

* "Applied Mechanics," London, 1869, p. 614.

Prolong the lines of action of W and P until they meet at C ; lay off $CD = W$, and DE equal to P , and parallel to the latter's line of action. Then, CE , the resultant of W and P , is equal in magnitude, opposed in direction, and has the same line of action as the virtual reaction R' from the bearing, since W , P , and R' are in equilibrium, and their lines of action must meet at a common point. Draw CEH , and, from the centre of pressure K , lay off $KH = R'$. This reaction is simply the resultant of the infinite number of small reactions from the bearing.

Draw the line of action OL of the normal reaction R through the point K ; resolve R' normally and tangentially. Then, $R = LK$ is the total normal pressure on the journal, and the force of friction $F = HL = KL \times$ coefficient of friction f . Since the virtual and normal reactions are, by definition, inclined from each other by the angle of friction, the angle $HKL = OKE = \phi$.

119. Friction Circle. In Fig. 129, drop the perpendicular OM from the centre O on the line of action of the reaction R' . Then, if r be the radius of the journal, $OM = r \sin \phi$. If now the radial arm ON and its force P be revolved through all positions about the centre O , it will be found that, while the location of the point of intersection C will be changed, the perpendicular distance of the line of action of R' from the centre will be equal, in every case, to $r \sin \phi$. Hence, the locus of such points of intersection as M is a circle described from O and of radius $r \sin \phi$. This is the *friction circle*.

The principle is general, applying to all forms of loading of a journal and bearing, either of which has motion relatively to the other. Thus, the dotted lines in the figure show the effect of anti-clockwise rotation, the force P having the new line of action CN' , but the other conditions remaining the same. It will be seen that, while the line of action of R' now assumes the similar but reversed position CQ , it is still tangent to the friction circle.

Thus far, the journal has been considered as the rotating member of the turning pair. If it be assumed that the journal is fixed and that the bearing revolves, carrying the downward load W ,—like a connecting rod pulling a crank pin,—the magnitude and lines of action of R' will remain the same for clockwise rotation and the reverse, but the centres of pressure will be changed from K and Q to K' and Q' , respectively, since the virtual reaction now acts upward from the journal through these points as virtual supports of the bearing.

Again, assume that the pressure acts upward instead of downward, as at (*a*), Fig. 129, and that the rotation is clockwise, the force P acting from N' to C . First, let the bearing be the moving member, as if the journal were the pin of a crank pressing upward against a link revolving on it. The centre of pressure will then be Q' , at which point R' will act downward on the journal. If, on the contrary, the journal be the moving member, the load will act upward and R' downward at the point Q . This case would be that of a connecting rod pushing a crank pin.

It will be seen that the friction circle and a tangent to it, which is the line of action of the virtual reaction R' , wholly replace either the journal or the bearing in the graphical investigation of their friction with any form of loading. The general law of sliding friction may be applied to determine on which of these tangents R' acts in any given case. Thus, either of the two members may be considered as having relative motion with regard to the other, and, hence, the virtual reaction of the stationary member is inclined from the normal reaction by the angle ϕ , in such a direction that its tangential component resists the motion of the other member.

120. Friction of Link Connections. In the preceding article, the effect of friction on the action of a single journal and its bearing was considered. A *link* is a straight machine member,

provided with two such bearings and used to connect the pins of two rotating cranks or levers or, like a connecting rod, those of a crank and a sliding member, as a cross head. If there were no friction, the radius of the friction circle would be zero and the force would be transmitted from one of the connected members to the other along the line joining the centres of the two journals, which line is the geometrical axis of the link. When friction is considered, the resultant of the transmitted force and the force of friction acts along the *friction-axis*, which is a line tangent to the friction circles of the two journals.

There are four fundamental cases of this action, two of which are represented in Figs. 130 and 131 and the others deduced therefrom. In each of these mechanisms, *A* is a link and *B* and *C* are hinged levers, *P* is a force acting upward on the lower or driving lever, and the dotted lines show the path in ascending. In analyzing the effect of friction on the force transmitted through the links of such mechanisms, there should be observed:

(*a*) The link may be assumed to be in equilibrium in any given position of the mechanism, but its efficiency, as thus determined, applies to that position only, and the direction of the friction-axis depends on which of the connected levers is the driver, and hence on whether the link is in tension or compression.

(*b*) A force and its reaction may be regarded simply as two equal and opposite forces, having the same line of action. Since the link is in equilibrium, the friction-axis is the line of action of a force acting from one journal and an opposing reaction from the other.

(*c*) The link-bearings move on the journals which engage them, the latter being thus relatively stationary. The direction of this motion is determined by that of the mechanism.

(*d*) Since the link is in equilibrium, the force of friction at either journal must so act as to oppose the relative motion of the

bearing. This consideration determines the direction of the friction-axis. If the direction of rotation is the same with both bearings, the axis will lie diagonally, being tangent to one friction circle on one side, and to the other, on the opposite side. If the bearings rotate in opposite directions, the friction-axis will be parallel to the geometric axis.

In Fig. 130, the lower lever, actuated by the force P , is the driver. Hence, disregarding friction, the force on the lower journal is concentrated at the point a on the geometric axis, acting there on the lower bearing of the link. This puts the latter in compression and its force acts on the lower side of the upper journal at the corresponding point b . From the path of the mechanism, the motion of both of the bearings is seen to be anti-clockwise. At the lower bearing, the tangential force of friction, $F = de$, acts from left to right, and therefore on the left side of the friction circle, where it and the normal pressure line cd' combine to form the resultant pressure line ce . Hence, the friction-axis is here tangent to the left side of the friction circle.

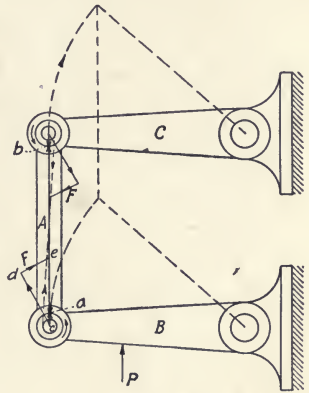

At the upper journal, F must act from right to left, combining with the reaction from the journal to form the virtual reaction, which, acting along the line ec , must be tangent to the right side of the friction circle. If, on the other hand, the upper lever be the driver in lifting the connected parts, the direction of motion of the bearings will be the same, but the link will be in tension and the friction-axis will be tangent to the other side of each friction circle.

In Fig. 131, the lower lever is the driver and the link is again in compression, but the direction of rotation of the two

bearings is not the same. Hence, the forces of friction act on the same sides of the two friction circles and the

friction-axis is parallel to the geometric axis. If, again, the upper lever be the driver in lifting the connected parts, the directions of motion of the bearings will not be changed, but the link will be in tension and the friction-axis, while still parallel to the geometric axis, will be tangent to the other sides of the friction circles.

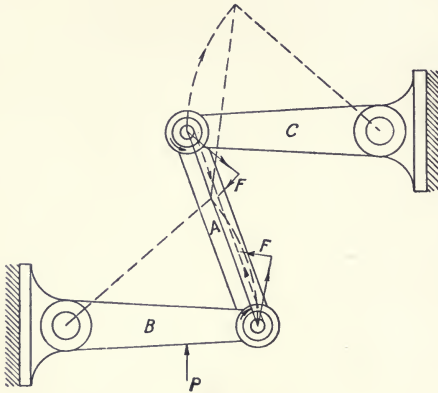

FIG. 131.

121. Chain Friction. The friction of a chain in passing over a chain drum or sprocket wheel is, in effect, a modified form of journal friction. Thus, let Fig. 132 represent a chain pulley whose effective radius is R and which is revolving in a clockwise direction. The load on the advancing or left side of the chain is W ; the driving force on the right, or receding, side is P . Let r be the radius of the pins joining the links and r_1 that of the wheel journal.

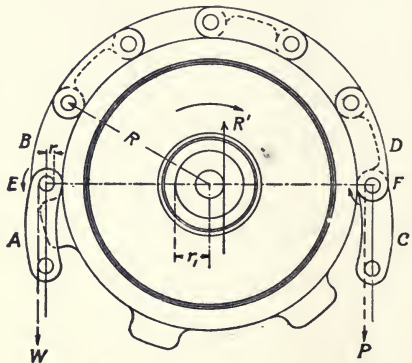

FIG. 132.

Relative motion of the links of the chain occurs only when the latter bends at the joints on reaching and leaving the horizontal diameter *EF* of the wheel. At this time, the advancing link *A* turns in an anti-clockwise direction on the link *B*, the

latter serving as a bearing; and, similarly, the link C is rotated in the same direction with regard to the link D . From Art. 120, it will be seen that the effect of these actions is to remove the lines of action of the load W and the driving force P from the vertical line passing through the centres of the link-pins to the left by the distance $r \sin \phi$, *i.e.*, the friction of the joints of the chain increases the leverage of the load and decreases that of the driving force by this amount.

Similarly, the line of action of R' , the vertical reaction of the wheel-bearing, is removed to the right through the distance $r \sin \phi$. R' is the resultant of P and W . Hence,

$$P = W \cdot \frac{R + (r + r_1) \sin \phi}{R - (r + r_1) \sin \phi}.$$

122. Ropes: their Internal Friction and Resistance in Bending. The resistance of a rope in passing on and off a sheave or grooved pulley has an effect, similar to that of chain friction, on the lines of action of the load and driving force, *i.e.*, the lever-arm of the load is increased, and that of the driving force decreased, by the same amount in both cases. This effect is not due, however, to the same causes as with the chain. In the rope, it is produced, when the latter is bent, by the relative motion and consequent friction of the strands, by the compression of the inner, and the stretching of the outer, fibres in winding on, and by the reversal of these actions when the rope leaves the pulley.

Thus, if we assume the rope to be wound on a pulley, like the chain in Fig. 132, it will be bent in advancing when it passes at E above the horizontal diameter EF , and will be straightened again when it descends below F at the right. In the first of these operations, the normal forces acting on the horizontal cross-section of the rope at E are the tension at the centre due to the load, the tension on the outer half from the stretching of those fibres, and the opposing compressive force on the inner

half. The resultant of these three forces is a tension which acts at a distance s outward from the centre of the rope, so that, neglecting the friction of the pulley-journal, the lever-arm of the weight W is $R + s$, R being the distance from the centre of the pulley to that of the rope.

When the rope straightens at F , the same forces act, but those of tension and compression from bending change places, occurring, respectively, on the inner and outer halves of the cross-section. Hence, the resultant tensile force acts between the pulley- and rope-centres, at a distance s from the latter, so that, neglecting journal-friction, the lever-arm of the driving force P is $R - s$. It will be seen that the distance s thus corresponds with the radius of the friction-circle for chain friction; and, as with the latter, considering journal-friction, we may write :

$$P = W \cdot \frac{R + r_1 \sin \phi + s}{R - r_1 \sin \phi - s}$$

in which $r_1 \sin \phi$ is the radius of the friction-circle for the journal of the pulley.

The value of s can only be expressed by empirical formulæ, the constants of which are derived from experiment. This follows, since the resistance of a rope to bending varies directly as the tensile stress in it due to the load or the driving force; directly as some power of its diameter, since the smaller the rope, the greater its pliability; and inversely as the radius of the pulley, since the greater this radius, the less the required bending. Evidently, it depends also upon the material of which the rope is composed, its length of service, etc.

Eytelwein's formula, as employed by Reuleaux and Weisbach,* gives, for the total resistance S to bending of a hemp rope in both winding on, and unwinding from, a pulley :

$$S = 0.472 W d^2 / r$$

* "Mechanics of Engineering and of Machinery," New York, 1896, Vol. I, § 197.

in which W is the load and d and r are, respectively, the diameter of the rope and the radius of the pulley, both in inches. The resistance to either winding or unwinding is then,

$$S/2 = 0.236 Wd^2/r.$$

But

$$Sr/2 = Ws.$$

Hence,

$$S = 0.236 d^2 \text{ inches.}$$

This formula, while approximate, is sufficiently accurate for hemp rope under heavy stress. For rope of other materials, the constant requires modification. The subject is treated more or less extensively in the works of Reuleaux, Weisbach, Hermann, and Thurston.

123. Friction of Spur-gear Teeth. In the transmission of power by gear wheels, a part of the lost work is expended in overcoming the frictional resistance of the teeth. This is due to the fact that a pair of teeth, while engaged, move one upon the other, the line of bearing changing continually on both contact-surfaces and the relative motion of the latter being a combination of rolling and sliding.

Figure 133 (a) represents the positions, at the beginning and end of engagement, of the same pair of involute teeth on the spur gears A and B , the wheel A being the driver and rotating in a clockwise direction. The two pitch circles are tangent at

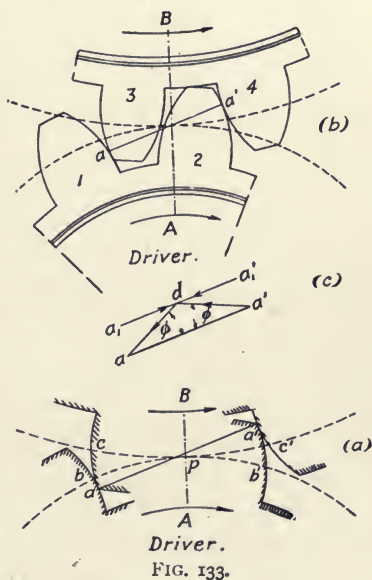

the point p on the line joining the centres of the wheels. The arcs bp and cp are the *arcs of approach*; pb' and pc' are the *arcs of recess*. The line aa' is the *line of action*, which is the path of the points of contact of the teeth during engagement. This line is normal to the contact surfaces, in properly formed teeth it always passes through the point p , and makes an angle with the horizontal, called the *angle of obliquity of action*.

In approach, the points b and c gradually draw nearer until they meet at p . Since the arc ab is shorter than the arc ac , it follows that the flank of the driving tooth rolls through a distance equal to ab on the face of the driven tooth, and slides for a distance equal to $ac - ab$. In recess, this process is reversed, the face of the driver rolling on the flank of the driven tooth through a distance equal to $c'a'$ and sliding through the distance $b'a' - c'a'$.

Figure 133 (*b*) shows the engaged portions of the two gear wheels A and B . In this figure, it is assumed that the lengths of the arcs of action, bpb' and cpc' in (*a*), are such that two pairs of teeth are simultaneously engaged, and that the normal pressure is the same between the teeth of each pair. The line of action is aa' as before.

If there were no friction, the reaction due to the load on the driven teeth 3 and 4 would act on the drivers 1 and 2 along the line $a'a$ from right to left, and this reaction would be exactly equal to the force P , exerted by the driving wheel and acting in the direction aa' and on that line. From the enlarged force polygon (*c*), it will be seen that, considering friction, the reaction from tooth 3 takes the direction da , and that from tooth 4, the direction $a'd$, both reactions being inclined to the normal by the angle ϕ and intersecting the line of centres at the point d . If these virtual reactions be resolved vertically and parallel to aa' , the vertical components will neutralize each other and the true line of action of the force and the resultant reactions will become $a_1'a_1$, parallel to $a'a$, and at a perpendicular dis-

tance therefrom of $\tan \phi \times aa'/2$, which, assuming aa' to be equal to the circular pitch, becomes $\tan \phi \times \text{pitch}/2$.

The friction of spur-gear teeth is then, in its effect, similar to chain friction. With frictionless motion, both the force and resistance would act along the normal aa' ; with friction, the line of action is shifted to the parallel line a_1a_1' . This change increases the distance from the centre of gear A at which the load from gear B acts on A , and decreases the distance from the center of gear B at which the driving force from gear A acts on B . Hence, in general, the leverage of the power is lessened and that of the load is increased by the distance as found above, $\tan \phi \times \text{pitch}/2$.

With cycloidal teeth, the line of action is not a straight line, as aa' , Fig. 133, but is an arc of the circle with which the profiles of the teeth are described. The loss from tooth-friction is less than with any other form, and the wear in service has, in consequence, less effect on the shape of the teeth.

124. Belt Friction. The friction of a belt on a pulley, in power transmission, is the friction of rest and not that of motion, in which respect it differs radically from the friction of mechanisms previously examined. Friction is, in this case, not the cause of lost work, but the means by which useful work is done, in preventing relative motion of the working parts; and the greater, within practical limits, it becomes, the better. With regard to the friction of motion of belt gearing, however, the reverse is true, the efficiency of such mechanisms being much less than that of toothed gearing, since, with the former, the power transmitted is directly proportional to the difference between the tensions of the tight and slack sides of the belt, while the aggregate thrust on the bearing which produces journal friction is due to the pull of both of these tensions.

The lost work of belt gearing is due to several causes:

(a) The stiffness of the belt and its consequent resistance to

bending in passing on and off the pulley; this is relatively so small as to be negligible.

(*b*) The driving and driven pulleys have, as is shown by Cotterill,* the circumferential speeds of the tight and slack sides, respectively, of the belt. The speed of the latter, at any given point, depends on its tension at that point. Hence, there is a loss of work from the creeping of the belt over the pulleys, which, in ordinary cases, may reach 2 per cent.

(*c*) Theoretically, a belt should not slip on the pulley, except under overload; practically, every belt slips to an extent which may be inappreciable, or, on the other hand, may reach 20 per cent. of its speed while it still drives and transmits power. The coefficient of friction increases with the slip, thus augmenting the work lost in moving the belt uselessly over the face of the pulley.

(*d*) Finally, the work lost in journal friction is, as explained above, relatively large.

The general theory of belting neglects "slip" and "creep," and assumes that the belt is perfectly elastic, *i.e.*, that its elongation is proportional to its tensile stress, an assumption which is not fully warranted for a material like leather whose initial stiffness increases with its stress. The theory serves, however, to show clearly the general principles governing the action of belting under the ordinary conditions of service.

Figure 136 represents a pulley *A* driving through belting a pulley *B*, the rotation being anti-clockwise. Let the initial tension of the belt, *i.e.*, that while at rest, be T_0 , and the tensions of the driving and slack sides during motion, T_2 and T_1 , respectively. If the belt were perfectly elastic, the sum of these two tensions would be equal to $2T_0$. Assume the pulley *A* as acted on by a driving force P whose arm is L , and the resistance of the driven pulley to be equivalent to a load W of arm l . When the pulley *A* begins to revolve, the right side of the belt is stretched and the left side slackened until the differ-

* "Applied Mechanics," London, 1895, p. 253.

ence, $T_2 - T_1$, between their tensions, is sufficient to overcome the resistance of the driven pulley, at which time

$$(T_2 - T_1)r = W \times l,$$

in which r is the radius of the driven pulley. If the mechanism be started under full load, the driving pulley will first slip under its belt, stretching the latter gradually on the driving side and thus increasing the tension T_2 until the moment of the difference of tensions is sufficient to overcome the moment of the resistance W .

This difference is constant with a uniform resistance, whatever the actual tensions of the two sides of the belt may be. If the magnitude of T_0 , and hence those of T_2 and T_1 , be increased by shortening the belt, or, with the same length, by separating further the shafts A and B , it is evident that, for equal moments of force and resistance on the driven shaft, the equation, as above, must still hold. Again, if the resistance be increased so that its moment is greater than the possible difference of tensions of a given belt, then the latter will slip, while, if the resistance be suddenly decreased with the same tension-difference, it will tend to creep.

The force of friction between a pulley and belt at any given point depends on the normal pressure between the two at that point and on the coefficient of friction. This normal pressure is proportional directly to the belt-tension at the given point. Thus, let Fig. 134 represent a pulley and belt at rest under the initial tension T , the arc of contact being 180° . Assume the mechanism to be frictionless, so that the tension of the belt is throughout equal to T .

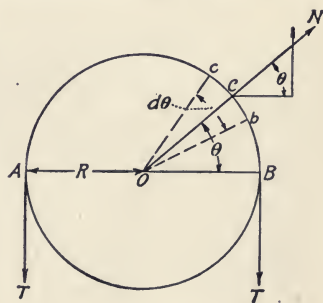

FIG. 134.

Let the angle $BOC = \theta$ and bOc be an elementary angle $d\theta$,

the length of the arc bc being $Rd\theta$, as R is the radius of the pulley. For convenience, take the width and thickness of the belt each as unity. N is the normal pressure acting at all points of the contact-surface. Then, the total radial pressure acting on the elementary strip of length $Rd\theta$ and area $Rd\theta \times 1$ will be $Rd\theta \times N$. Resolving N parallel and perpendicular to the diameter AB , we have $T = N \sin \theta$, so that the element of tension, due to the strip $Rd\theta$ and perpendicular to AB , is $Rd\theta \times N \sin \theta$, and the sum of these elements for the two sides of the belt is :

$$2 T = NR \int_{\pi}^0 \sin \theta d\theta = 2 NR,$$

whence,

$$N = T/R.$$

This principle is general, but, owing to the action of friction, the tension in the belt, and hence the normal pressure, increase from the slack side to the driving side of the belt and through

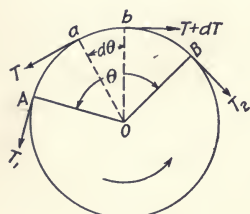

FIG. 135.

the arc of contact, in proportion to the lengths of the radii vectors of a logarithmic spiral. Thus, in Fig. 135, let the angle of contact be $AOB = \theta$, and let aOb be an elementary angle $d\theta$. The tension at a is T and that at b is $T + dT$. The increment of tension, dT , in passing through the elementary angle $d\theta$, must

be due to the force of friction on the strip ab , which force is the product of the area of the strip by the normal pressure $N = T/R$ and the coefficient of friction. Hence :

$$dT = Rd\theta \times \frac{T}{R} \times f,$$

$$\int_{T_1}^{T_2} dT/T = f \int_0^\theta d\theta,$$

$$\text{Hyp. log } T_2/T_1 = f\theta,$$

$$T_2/T_1 = e^{f\theta},$$

in which e is the base of the Napierian system of logarithms and

θ is given in circular measure. With the common system of logarithms and θ expressed in degrees :

$$\text{Common log } T_2/T_1 = 0.007578 f\theta.$$

In Fig. 135, the belt is assumed to be fully loaded, so that the tension-difference and the tension-ratio, as computed, are each a maximum value which cannot be exceeded without slip of the belt. The normal pressure at the contact-surface is reduced to some extent by centrifugal action on the belt, which should be considered at high speeds, since it not only increases the tendency to slip but also adds materially to the tension of the straight length of the belt on the driving side. In practice T_2/T_1 ranges between 2 and 3, and the coefficient of friction, roughly, from 0.2 to 0.4.

The graphics of belt gearing present no problems which have not been examined in previous mechanisms. Each pulley may be considered as in equilibrium under the action of a driving force or a resistance, the two tensions, the normal reaction of the bearing, and the journal friction, the latter being relatively large. Thus, in Fig. 136, the angle of contact, θ , can be found by construction, and, from the formula, $T_2/T_1 = e^{f\theta}$, the ratio between the two tensions can be determined. Prolong the lines of action of the latter until they intersect at O , and from O lay off OC and OD of such dimensions that OC/OD is equal to the tension-ratio just found. Their resultant OE gives the line of action of the resultant T of T_2 and T_1 , which line inter-

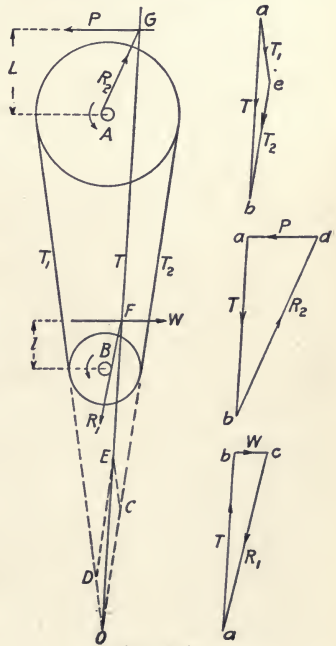

FIG. 136.

sects the lines of action of the resistance W and the driving force P at the points F and G , respectively. From the latter points and tangent to the friction circles, draw the lines of action of R_1 and R_2 , the virtual reactions of the bearings.

The driven pulley B is in equilibrium under the action of the resistance W , the resultant T of the tensions, and the virtual reaction R_1 , the magnitude of W and the lines of action of all the forces being known. In the lowest force triangle, lay off $bc = W$, and draw ba and ca parallel, respectively, to the lines of action of T and R_1 , thus determining the magnitudes of the two latter. To find the magnitude of P , consider the driving pulley as similarly in equilibrium and lay off, in the second triangle, $ab = T$, and draw ad and ab parallel to the lines of action of P and R_2 , respectively. The magnitude of the tensions is determined in the upper force triangle by resolving the resultant T of the tensions parallel to the lines of action of its components T_1 and T_2 . The effect of journal friction can be shown by replacing R_1 and R_2 by reactions passing through the centres of the respective journals, and drawing the corresponding sides of the force triangles parallel thereto, which will give the values, excluding journal friction, of P , T , T_1 , and T_2 , for the same resistance W .

125. Rolling Friction. As compared with sliding friction, rolling friction is immaterial in magnitude. The principles which govern its action are not clearly understood. It differs from sliding friction in this, that the coefficient of friction of the latter may be assumed to be dependent only on the nature of the materials in contact, while, with rolling friction, there is an added factor in the diameter of the rolling cylinder. The latter, in very soft materials, makes an indentation or rut, so that the resistance to movement is due to both the weight on the roller and the work necessary to displace material in indentation. With all other bearing materials, elasticity acts in greater or

less degree, tending to produce surface friction where the material closes in at the front and rear of the indentation. Since the greater the radius, the flatter the arc of a wheel, it is evident that the depth of the rut made by the latter is affected by its radius.

These considerations lead to the general formula :

$$P = eW/r,$$

whose results must be considered as very approximate. In this formula P is the force necessary to draw the roller, r is the radius of the latter in inches, W is the weight on the axle, and the coefficient e ranges from 0.02 for smooth, hard substances to 0.09 for those of opposite character.

When sufficient force is applied to a roller resting on a plane surface to bring it to the limiting condition of equilibrium, *i.e.*, when with any increase of force it will begin to roll, the cylinder is under the action of the force P applied as draught at its axis, the weight W , the latter's equal and opposite normal reaction R , and a force of friction F acting transversely to the line of contact of the roller and plane. The direction of the resultant of P and W gives the line of action of the virtual reaction R' , as in sliding friction. The horizontal component of this reaction represents the magnitude of the force F . The graphical analysis is, therefore, similar to that of sliding friction.

126. Examples. The following examples are given to illustrate or extend the graphic methods given in the preceding articles.

Figure 137 represents in diagrammatic form the ordinary stationary steam engine. Only centre lines and the friction circles are shown,

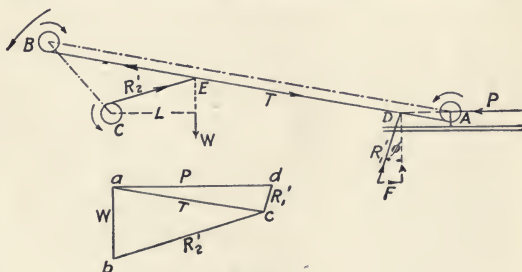

FIG. 137.

A being the bearing of the crosshead pin, and B and C , those of the crank-pin and shaft, respectively. The arrows at the friction circles show, for this position of the revolving parts, the direction of motion of the rotating member of each turning pair, *i.e.*, the two bearings of the connecting rod and the shaft in its bearing. Let the crank have clockwise rotation and its motion be opposed by a known resistance W of lever-arm L . It is required to determine the net force P —excluding the friction of piston rod and piston—exerted in the cylinder at this point in the forward stroke.

From Art. 120, it will be seen that the line of action of the thrust T of the connecting rod is tangent to the lower sides of the friction circles at A and B . The crosshead is in equilibrium under the action of P , T , and the virtual reaction R_1' from its slipper bearing. This reaction makes the angle of friction with the normal to the bearing, and the location of R_1' is determined

by the fact that it must pass through the intersection D of the lines of action of P and T . Similarly, the crank is in equilibrium under the action of T , W , and the reaction R_2' from the shaft bearing C , which reaction is tangent to the upper side of the friction circle and passes through the point E where W cuts T . In the force polygon, lay off ab

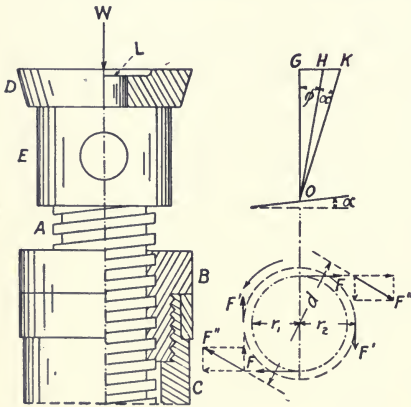

FIG. 138.

$= W$, and draw ac and bc parallel to T and R_2' , respectively. Similarly, lay off ad and cd parallel, respectively, to P and R_1' . Then, ad represents the magnitude of the required force P , on the scale adopted.

Figure 138 represents the upper part of an ordinary screw

jack. The screw A engages the nut B , fixed in the supporting frame C ; the load W rests on the swivel-plate D , journalled on the screw-head E , the latter being bored for the bar by which power is applied to turn the screw and lift the load.

Let the circle of radius r_1 be the horizontal projection of the mean helix (Art. 115) of pitch-angle α , on which the two halves of the load W may be assumed to be concentrated at two points diametrically apart. Lay off the vertical line $OG = W/2$, draw GK horizontally, and make GOH equal to the angle of friction and HOK equal to the pitch-angle. Then, GK represents the magnitude of the force of friction, F , acting at each of the points of application of the load $W/2$ on the mean helix.

Again, let r_2 represent the mean radius of friction of the collar bearing (Art. 117) between the swivel-plate and head, and assume, as before, that the load W is divided and concentrated at two diametrically opposite points on a circle of this radius. Then, GH represents the magnitude of the force of friction, F' , acting at each of these two points. These two couples, when combined, form a resultant couple of force F'' and arm d , which couple measures the resistance of the screw-thread and the collar-bearing at the swivel-plate.

Since it is impossible to make the load W absolutely central, there will also be journal friction on the pin L , on which the plate is centred. The amount of this resistance will depend on the eccentricity of the load and the resulting normal pressure on the pin. If this pressure be known, the frictional resistance can be determined by the methods of Art. 118.

Professor Hermann * gives the method shown in Fig. 139 for finding the relation of load and power, and the tensions in the various portions of a chain or rope passing over the sheaves of the pair of blocks of a tackle, friction being considered.

* "Graphical Statics of Mechanism," Hermann-Smith, New York, 1904, p. 88.

In Fig. 139, the blocks are three-sheaved; the load W is suspended from the lower or movable block A , and the frame C of the upper or fixed block B is supported from above.

The rotation of the sheaves in raising the weight is clockwise, the rope winding on at D and E , and off at F and G . If the upper or fixed end be secured to the hanger C , as at T_1 , there will then be seven portions of the rope whose tensions, T_1 to T_7 , are to be determined, the last, or that of the hauling end, being equal to the lifting force P .

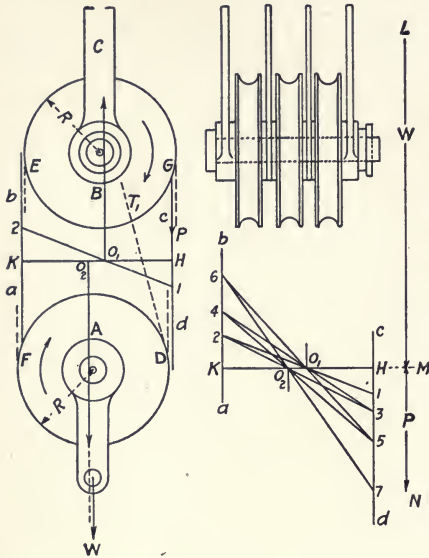

FIG. 139.

For any two consecutive sections of these seven — one on each side of a sheave of either block — the tension in the rope on one side constitutes the load, and that on the other, the power for the pair. If R be the effective radius of the sheave, r_1 that of the block-journal, and t be equal to $r \sin \phi$ as in Art. 121, or to s as in Art. 122, then, from these articles, the relation between the power p and the load w on these two portions, for either a rope or chain, will be :

$$p = w \cdot \frac{R + r_1 \sin \phi + t}{R - r_1 \sin \phi - t}$$

At the journal of the lower block, the load W acts on the vertical tangent to the left (Art. 120) of the friction circle; at the upper journal the reaction of the support C acts on the similar tangent to the right. Again, from the figure, it will be seen that the unwinding or power side is the left on the lower

block and the right on the upper, the tensile forces in the sections of rope or chain acting, in each case, at a distance $R - t$ from the centre, as shown by the full lines ab and cd ; similarly, on the respectively opposite, or load, sides of the blocks, the tensile forces act at a distance $R + t$ from the centre. Hence, as the lower block is free, it will, when ascending, swing to the left for a distance $2t$, as shown in the figure, so that the tensile forces shall act vertically. When motion ceases, the block swings backward until it is again vertically below the upper block; when the load is lowered, this process is reversed.

In passing from the fixed end of the rope or chain at the upper block to the free or hauling end, its tension is increased, whenever it passes over a sheave, in the ratio given by the reciprocal of the fraction in the preceding equation. Hence, starting at the fixed end, the general expression for the ratio between the tensions in two consecutive sections is

$$\frac{T_n}{T_{n+1}} = \frac{R - r_1 \sin \phi - t}{R + r_1 \sin \phi + t}.$$

In the left-hand figure, draw the horizontal line HK , cutting the lines of action of the rope tensions ab and cd at K and H , respectively, and those of the load W and the reaction from the upper bearing at o_2 and o_1 , respectively. Then, $HK = 2R$, and the distances:

$$\begin{aligned} Ho_1 &= Ko_2 = R - r_1 \sin \phi - t, \\ o_1o_2 &= 2r_1 \sin \phi + 2t, \\ Ho_2 &= Ho_1 + o_1o_2 = Ko_1 = R + r_1 \sin \phi + t. \end{aligned}$$

Assume that the tension T_1 in the first section from the fixed end is known and is equal to H, I on the line cd . From I draw through o_1 the line $I, 2$, cutting the line ab at 2 . Then $K, 2$ is equal to the tension T_2 in the next succeeding section, for the triangles H, I, o_1 and $K, 2, o_1$ are similar, and

$$\frac{H, I}{K, 2} = \frac{Ho_1}{Ko_1} = \frac{R - r_1 \sin \phi - t}{R + r_1 \sin \phi + t} = \frac{T_1}{T_2}.$$

Continuing in the right-hand diagram, draw from the point 2 through o_2 the line $2, 3$, and, by similar reasoning, $H, 3$ is the tension T_3 in the third section. In the same way, $K, 4 = T_4$, $H, 5 = T_5$, $K, 6 = T_6$, and $H, 7 = T_7 = P$ are found. The sum of the tensions, T_1 to T_6 , inclusive, which is the line LM , is equal to the load W , while the force P is on the same scale equal to MN .

Since the distances Ho_1 , Ho_2 , Ko_1 , and Ko_2 are constant for any system of sheaves, such as is shown in the figure, it is evident that the ratio MN/LM is constant, and that any value of T_1 may be assumed in finding the ratio. When the latter is determined, the value of P , for any value of W , is given by the expression,

$$P = W \cdot MN/LM.$$

Figure 140 represents the pitch circles of a train of spur gears, A , B , and C , with involute teeth. The power applied to the driving gear A is equivalent to a force P of arm L ; the resistance acting on the gear C is equal to a force W of arm L' . Assuming friction at the wheel journals and between the engaged teeth, it is required to determine the magnitude of the force P for a known resistance W .

The driving gear A is in equilibrium under the action of the force P , the reaction T_1 from the teeth of gear B , and the virtual reaction R_1 from the bearing. By Art. 123, the reaction T_1 is parallel to the line aa' passing through the point of tangency of the pitch circles, the distance of T_1 from the centre of A being greater than that of aa' by

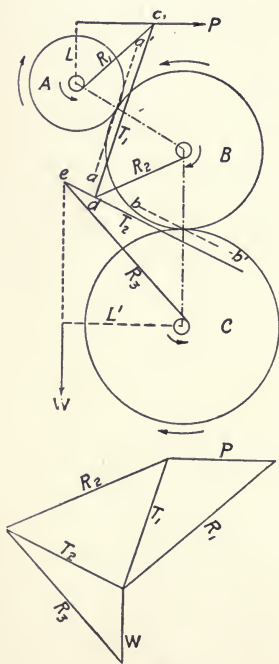

FIG. 140.

the amount given in the article cited. The lines of action of P and T_1 intersect at c , and the reaction R_1 drawn from c is, by Art. 120, tangent to the lower side of the friction circle.

The intermediate gear B is in equilibrium under the action of the force T_1 , the reaction T_2 from the teeth of gear C , and the vertical reaction R_2 from the bearing. Since the gear B is the driver for gear C and its motion is opposite to that of gear A , the reaction T_2 has, by Art. 123, the direction and location shown in the figure, being parallel to the line bb' passing through the point of tangency of the pitch circles. The lines of action of T_1 and T_2 intersect at d , from which point the reaction R_2 is drawn tangent to the lower side of the friction circle.

The driven gear C is in equilibrium under the action of the resistance W , the force T_2 and the reaction R_3 from the bearing. The lines of action of T_2 and W meet at e , from which point the reaction R_3 is drawn tangent to the upper side of the friction circle.

The directions of all the forces acting on the train and the magnitude of one, the resistance W , are known. Starting with the latter, the force polygon is constructed in the customary way.

NOTE.—Within the limits of a single chapter, it has been possible to give only a brief review of the general principles of this subject. For the full analytical treatment of friction in mechanisms and machines, the student is referred to Kennedy's "Mechanics of Machinery" and to Thurston's "Friction and Lost Work in Machinery and Mill Work." Professor Gustav Hermann was the pioneer in the application of graphical methods to mechanism, and his admirable work, "The Graphical Statics of Mechanism," presents these methods in detail, with numerous examples. A summary is also given in Weisbach's "Mechanics of Engineering and of Machinery," Vol. III, Part I, Section II, Appendix.

PROBLEMS

94. A bell crank has two arms at an angle of 90° . When at rest, one arm is horizontal, the other vertical. The horizontal arm has a weight W suspended from it by a link journalled on a crank-pin fitted at its outer end; the power P is applied in a horizontal line at the upper extremity of the vertical

arm, the latter being twice the length of the horizontal arm. Find the magnitude of P for a given value of W , when the bell crank has rotated through 45° , considering the friction at the bearing of the bell crank and that at the link-bearing.

95. Find the relation between the power P and the resistance W in a turn-buckle with right- and left-handed screws, considering friction as occurring only between the screw-threads and their nuts.

96. Draw the force polygons for four positions, 90° apart, of the crank of the ordinary beam engine with vertical cylinder, such as is used in marine service, considering friction throughout except that of the piston and piston-rod.

97. Draw the force polygon for an eccentric whose rod is directly connected with a valve-rod. Consider all friction.

98. Find graphically the efficiency of worm-gearing.

99. Draw the force polygon for a Prony friction-brake.

100. Considering friction, find graphically the forces which must be applied during forward and backward movement of a differential pulley carrying a known weight W .

101. Considering friction, draw the force polygon for a horizontal shaft resting in a ball-bearing.

CHAPTER XI

MOMENT DIAGRAMS FOR SHAFTING

THE stresses to which shafting is subjected are those due to bending or twisting, or to both of these actions. Thus, in a marine engine, the pressure on each crank-pin and the corresponding reaction from the adjacent shaft-bearing form a couple which can be resolved into a second couple tending to bend the shaft, and a third which acts to twist it. The torsional moment thus produced by one or more cranks is transmitted through the crank-shaft, is resolved into cross-shear at the coupling bolts, and again transformed into a twisting moment in the line-shaft, where, neglecting the weight, no action but torsion exists. The thrust- and propeller-shafts, revolved by torsion, are, in addition, subjected to bending, the former by the unbalanced thrust of the "horseshoe" bearing, the latter by the weight of the propeller and the oblique forces from its blades.

Similar conditions exist in stationary engines and mill work. The shaft rests in bearings or hangers, which correspond with the supports of a beam. The loads upon it are its own weight, and, between two or more bearings, those of pulleys or a fly-wheel with their belt-tensions, or the thrust of the connecting-rod on the crank-pin. These loads tend to bend the shaft, precisely as with a beam, except that, since the shaft revolves, there is a reversal of bending stress in each fibre during each revolution, and, further, the action of the belts may cause a swaying of the shaft, with a similar, but momentary, reversal of stress. Finally, the ordinary shaft is twisted between the driving mem-

ber, as a crank or pulley, and the driven member, a pulley, gear, or fly-wheel, and this twisting produces a torsional shearing stress.

These two actions, bending and torsion, must, in any event, be examined separately. In finding the required diameter of a section of shafting for given conditions, the character and locations of the loads determine as to which of the two stresses, or both, are of importance. Thus if, in mill work, there are no pulley or other loads between adjacent hangers and if the diameter is relatively small and the shaft is not deflected otherwise than by its own weight, the latter may be disregarded and the torsional stress alone considered, the diameter being made large enough, however, to prevent the twist of the shaft exceeding 1° in an axial length of about 20 diameters.

If, on the other hand, pulleys with heavy belt-tensions are located on the section at such a distance from the nearest hanger as to make the bending effect of their loads marked, the stress due to torsion may be immaterial as compared with that from flexure. The shaft may, therefore, be either designed for bending only, with a limitation in deflection under load to at least $\frac{1}{1200}$ of the length between bearings, or, for greater accuracy, the combined effect of bending and twisting may be determined by the formulas of Rankine or Grashof (Art. 50), and the diameter of the shaft found for the resultant stress.

In any event and for all classes of shafting, the limit of safe working stress should be fixed by the character of the strains to which the shaft is subjected from bending, twisting, and the frequency of stress-reversal.

127. Shear and its Resultant Stresses. As stated previously, the twisting of a shaft develops shearing stress on planes normal to the axis. The magnitude and effect of the vertical shear in beams has been discussed (Arts. 55, 56). It will now be shown that shearing force cannot exist alone, but that, for equilibrium, there must be resultant stresses produced by it.

(a) *Horizontal Shear.* Let $abcd$, Fig. 141, represent one face of a cube of unit length, subjected on the sides ab and cd to the vertical shear V , which is assumed to be of equal intensity on both of these sides. The two forces V form a couple whose arm is unity and which acts to cause clockwise rotation of the cube. For equilibrium, an opposing couple must exist whose forces V' have the same magnitude as V , since the arm is of the same length in both cases. The principle that the vertical shear always produces thus a horizontal shear is general. If the sections ab and cd be considered as indefinitely near each other, the effect of the weight of the material between them may be disregarded, and the two forces V will be equal to each other and to V' .

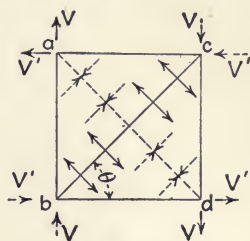

FIG. 141.

(b) *Tension and Compression Due to Shear.* The resultant of the forces V and V' at a and d is a tensile force acting to part the cube on the diagonal plane bc . Similarly, the resultant of these forces at b and c is a compressive force normal to the plane ad . The magnitude of these resultant forces depends on the angle θ of the diagonals; it is a maximum when $\theta = 45^\circ$. Its intensity, *i.e.*, the tensile or compressive unit-stress, is equal to the corresponding resultant force, divided by the area of the diagonal plane whose trace is ad or bc .

(c) *Coefficient of Elasticity for Shearing.* There is a definite relation between this coefficient (Art. 53) and those for tension and compression, the value of the former being about two-fifths of those for either of the two latter stresses. For cast iron, wrought iron, and steel, E , for shearing, is 6, 10, and 11 millions, respectively.

128. Torsion. Figure 142 represents a counter-shaft, supported by hangers at A and B , carrying driving and driven pulleys, C

and D , respectively, and rotating in a clockwise direction when viewed from the right. Each pulley is placed against its adjacent bearing, so that, for the length l between pulley-centres,

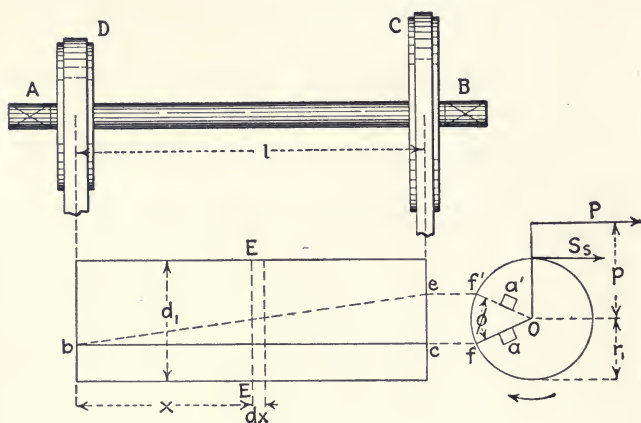

FIG. 142.

the shaft is virtually subjected to torsion only, if its weight be disregarded. This section is shown below to an exaggerated vertical scale. The shaft is solid and cylindrical. The effect of the driving pulley is equivalent to that of a force P with lever-arm p ; the driving and twisting moment is hence

$$P \times p = M^t.$$

Let bc be a line scribed parallel to the axis when the shaft is at rest. When motion begins, the load on the belt of pulley D holds the left end back, the belt-tension on C pulls the right end forward, and the shaft is twisted, so that, when uniform motion is attained, the line bc assumes the spiral form shown approximately by the dotted line be . The consequent radial displacement is represented on the elevation to the right, an elementary area a , originally on the radius of of , moving, through the angle ϕ , to a' with radius of' . Within the elastic limit, the angles ebc and ϕ increase with the moment Pp ; if the length l be extended, ϕ will grow proportionately for the same twist,

while ebc remains constant. The angle ϕ is the *angle of torsion* of the section at ec , with regard to that at b .

Assume that the section of length l , instead of being a solid cylinder, is composed of a number of thin circular plates strung on the axis, and let the line bc be scribed as before. Then, shift the plates until the points thus marked form the spiral be . It is evident that each plate must move, with regard to the next one to the left, by the amount of increase of the angle of torsion for that section. If now the plates be considered as indefinitely thin, the transverse motion and distortion which are thus required will reduce torsion, in effect, to shearing force applied normally to the radii of the shaft. Since the latter is uniform in cross-section throughout, and since that cross-section is circular, it is evident that the relations of shearing stress and deformation are the same for all cross-sections and for all elementary areas of the same radius in the same cross-section.

(a) *Unit Shearing Stress.* Consider any section as EE , distant x from the left-hand end, and an adjacent section distant dx to the right of it. Let r_1 be the external radius of the shaft. In twisting, the section to the right will rotate with regard to the other section, through the angle $d\phi$, or the arc $r_1 d\phi$, which is the total deformation at the radius r_1 and through the axial distance dx . Hence:

$$\text{unit-deformation } s \text{ at radius } r_1 = r_1 \frac{d\phi}{dx} = r_1 \frac{\phi}{l},$$

in which ϕ is taken in circular measure.

Let S_s be the unit shearing stress at the radius r_1 and E be the coefficient of elasticity for shearing. Then, by the definition of E (Art. 53):

$$S_s = Es = Er_1 \frac{d\phi}{dx} = Er_1 \frac{\phi}{l}.$$

The stress is hence directly proportional to the radius. The stress S_s' at the radius r is then:

$$S_s' = S_s \cdot \frac{r}{r_1}$$

(b) *Moment of Resistance.* Assume a concentric annulus in the cross-section EE , of width dr and radius r . Then :

$$\text{Area of annulus} = 2\pi r \times dr,$$

$$\text{Stress on annulus} = 2\pi r dr \times S_s' = \frac{2\pi S_s}{r_1} \cdot r^2 dr,$$

$$\text{Moment of stress about axis} = \frac{2\pi S_s}{r_1} \cdot r^2 dr \times r = \frac{2\pi S_s}{r_1} \cdot r^3 dr.$$

The moment of resistance to shearing of the entire cross-section at EE is the summation of the moments of the series of concentric rings of width dr , extending from the centre outward. Hence :

$$\text{Internal resisting moment} = \frac{2\pi S_s}{r_1} \int_0^{r_1} r^3 dr = \frac{\pi S_s r_1^3}{2} = \frac{S_s J}{c},$$

in which J is the polar moment of inertia (Art. 49) of a circular section, and $c = r_1$ is, as in beams, the distance of the most remote fibre of the cross-section of the shaft from the centre of gravity of that cross-section.

(c) *Relative Resistance to Bending and Shearing.* From the above and by Art. 62 we have :

$$\text{Moment of resistance to torsion} = S_s J/c,$$

$$\text{Moment of resistance to bending} = SI/c,$$

in which I is the rectangular moment of inertia of the cross-section. For a circular section, $J = 2I$. Hence, if $S_s = S$, the resistance of the shaft to torsion is twice that to bending. This is true also for hollow shafts.

(d) *Hollow Shafts.* The formula deduced above for the resisting moment to torsion is general, if the proper values of J and c be substituted in it. For :

Hollow cylindrical shaft, external diameter, d_1 ; internal, d ;

$$J = \frac{\pi}{32}(d_1^4 - d^4),$$

Solid cylindrical shaft of diameter d_1 , $J = \frac{\pi}{32} \cdot d_1^4$.

The distribution of the material of a solid shaft is uneconomical with regard to torsion, since the resisting stress is a maximum at the outer surface and falls to zero at the centre. The core removed from a hollow shaft is, therefore, virtually ineffective in resistance, and such shafts are stronger than solid shafts of the same sectional area. From the values of J , as given above, it will be seen that the angle of torsion of the hollow shaft is the difference between those of two solid shafts of diameters d_1 and d , respectively.

(e) *Angle of Torsion.* For the section at ec , distant l from that at b , we have:

$$M_t = S_s \frac{J}{c} \text{ and } S_s = \frac{Er_1\phi}{l},$$

in which $c = r_1$ and ϕ is in circular measure. Substituting and solving:

$$\phi = \frac{lM_t}{EJ}.$$

For a section distant x from b , the corresponding value of the angle of torsion in circular measure will be found by substituting x for l . In angular measure, this expression becomes for:

$$\text{Solid shaft, } \phi = \frac{584 lM_t}{Ed_1^4},$$

$$\text{Hollow shaft, } \phi = \frac{584 lM_t}{E(d_1^4 - d^4)}.$$

129. Torsion and Bending Combined.—If, Fig. 143, a tensile force P be applied to the bar ab , this force can be resolved into

tensile forces normal to, and shearing forces along, any plane, as cd , not normal to, nor coinciding with, the line of action

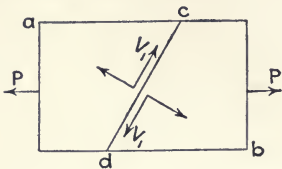

FIG. 143.

of P . Similarly, if P were compressive, there would be compressive forces normal to, and shearing forces along, the plane cd . Hence, when a tensile or compressive force, as P , is applied to a body, a shearing force V_1 exists on any plane, as cd , inclined to the line of action of the force at an angle less than 90° . This result is the converse of, and follows from, the principles established in Art. 127.

Again, assume, as in Fig. 144, that the bar is a parallelepipedal element, subjected to both a tensile force P and a vertical shear V . By Art. 127 (a), there will exist also a horizontal shear V' . These three forces can be resolved normal and parallel to the diagonal plane ab , giving a tensile force T and a shearing force V_1 , along the diagonal, each of the two latter forces reaching a maximum with a certain value of ϕ , the angle of inclination of the diagonal.

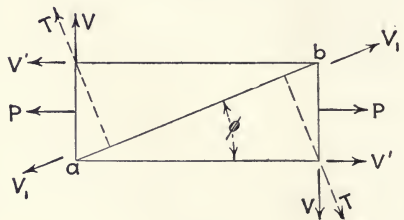

FIG. 144.

Equations (1) and (6), Art. 50, give the maximum resultant tensile and shearing unit-stresses, respectively, as deduced from these considerations; and equations (7) and (2), the equivalent twisting and bending moments for bodies of circular cross-section, as a shaft.

When a shaft is subjected to torsion only, the maximum tensile stress acts, as in Fig. 141, on the diagonal at an angle of 45° with the axis. If, in addition, the shaft be bent by applied loads which produce axial tensile and compressive stresses, the angle of maximum tension becomes greater than 45° ; and, if

the shaft yield, the fracture, while still spiral, will be more nearly transverse to the axis than a similar fracture from pure torsion.

When, as is usual, it is necessary to consider both stresses in determining the diameter of a shaft, the resultant or equivalent moment, either for twisting or bending, can be found by the methods of Art. 50. The diameter is then made large enough to keep the corresponding stress within safe working limits.

130. Axles. The term 'axle' is somewhat elastic in general application. In the examples which follow, it will be restricted to short lengths of revolving or oscillating shafting, which do not transmit power by torsion and which, therefore, are subjected to bending only from the loads carried. Under these conditions, the axle is essentially a beam, except that, when rotating, there is a reversal of stress in every fibre during a complete revolution. There are three cases: the load may act normal to, inclined to, or parallel with the axis.

(a) *Load Normal and between Journals.* Fig. 145 represents an axle with journals at A and B and carrying a vertical load P at C , the centre of the hub-seat. The resultants, R_1 and R_2 , of the upward pressures on the journals are assumed to act at the respective centres of the latter. From a , on the line of action of R_1 , lay off $ae = P$, and to

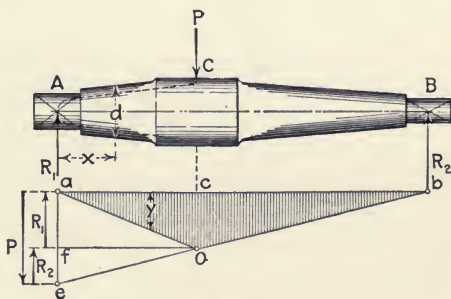

FIG. 145.

b , where the horizontal line ab meets the line of action of R_2 , draw cb intersecting the line of action of P at O . Project O to f on ae . Then, $fa = R_1$, since, taking moments about B :

$$P \times BC = R_1 \times AB,$$

$$P : R_1 :: ae : cO : af.$$

whence,

$$P \times BC = R_1 \times AB,$$

whence,

$$P : R_1 :: AB : BC :: ae : cf : ad.$$

From any pole O on cd , draw the rays Od , Oa , and Oe of the force polygon, and construct the corresponding equilibrium polygon and bending moment diagram, DEF . As shown in (a), the diameter of the axle at any given point can be found from the ordinates of this diagram, if a proper value of the working stress S be assumed.

(c) *Load between Journals and Inclined to Axis.* Fig. 147 represents an axle having the hub-seat between the journals,

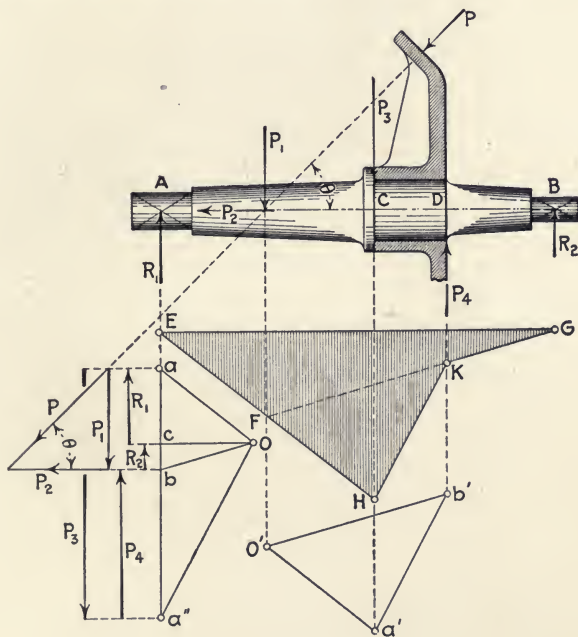

FIG. 147.

A and B , and the line of action of the load P inclined to the axis by the angle θ .

Resolve the force P into vertical and horizontal components, P_1 and P_2 , respectively. The former acts to bend the shaft; the

latter to produce horizontal thrust on the bearing A and on the collar at C . On the lines of action of R_1 , P_1 , and R_2 , draw any triangle, as EFG . This triangle is the equilibrium polygon for these forces. From any pole O , draw the rays Oa , Ob , and Oc , parallel respectively to the sides EF , FG , and GE . Then, $ab = P_1$, $ca = R_1$, and $bc = R_2$.

The inclined force P produces a downward thrust P_3 on the left end C of the hub-seat and an upward thrust P_4 at the other end D . The true vertical forces acting on the axle are then R_1 , R_2 , P_3 , and P_4 . The force P_1 is evidently the difference between the forces P_3 and P_4 , and the three forces are in equilibrium. Hence, construct the equilibrium polygon, $O'a'b'$, on the lines of action of P_1 , P_3 , and P_4 , with $O'a'$ and $O'b'$ parallel, respectively,

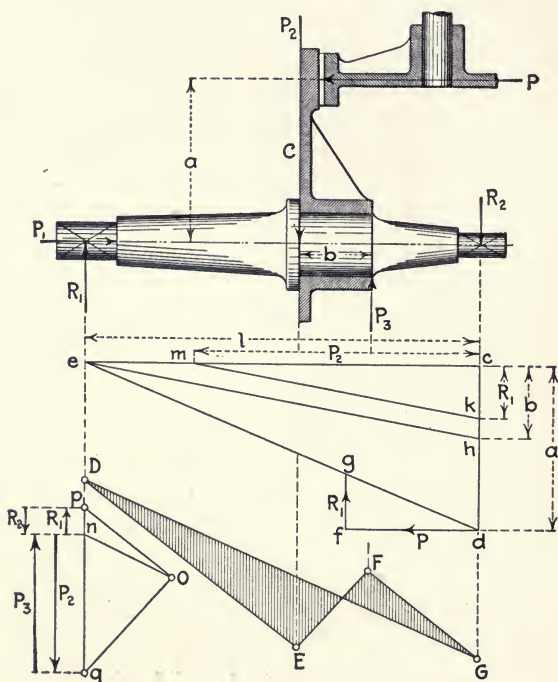

FIG. 148.

to Oa and Ob ; and, from O , draw Oa'' parallel to $a'b'$. Then, $aa'' = P_3$ and $a''b = P_4$. Prolong EF to H on the line of action of P_3 , and, from H , draw HK parallel to $a'b'$. The equilibrium polygon and bending moment diagram for the forces P_3 and P_4 and the reactions R_1 and R_2 is then $EHKG$.

(a). *Load between Journals and Parallel to Axis.* Figure 148 represents an axle driven by friction gearing, which produces a horizontal thrust P at the distance a from the axis. The driven wheel C is keyed on a boss of length b , between the journals A and B , the latter being distant l from centre to centre.

The force P develops an equal and opposite reaction P_1 from the bearing of the journal A , the two constituting a couple (Art. 27) of arm a . Similarly, the pressure of the axle is downward at the left end and upward at the right. Hence, the reactions, R_1 and R_2 , are, respectively, upward and downward forces, are equal, and form a couple of arm l . The axle is in equilibrium under the action of these opposing couples. Therefore

$$R_1 \times l = P \times a.$$

To determine the magnitude of $R_1 = R_2$, lay off $cd = a$ and $ce = l$, and draw de . From d , set off $df = P$ parallel to ce and draw fg parallel to cd . Then, the triangles cde and fgd are similar, and $fg = R_1 = R_2$, since:

$$\begin{array}{l} \text{or} \\ \text{and} \end{array} \quad \begin{array}{l} fg : fd :: cd : ce, \\ R_1 : P :: a : l, \\ R_1 \times l = P \times a. \end{array}$$

The force P also produces, and is equivalent to, a downward thrust P_2 at the left end, and an upward thrust P_3 at the right end, of the hub-seat. These two forces form a couple of arm b . The axle is in equilibrium under the action of the two opposing vertical couples, R_1, R_2 and P_2, P_3 . Hence:

$$R_1 \times l = P_2 \times b.$$

To determine the magnitude of $P_2 = P_3$, lay off $ch = b$ and

$ck = R_1$. Draw he and km parallel thereto. Then the triangles che and ckm are similar, and $cm = P_2 = P_3$.

On the load-line pq , lay off $np = R_1$ and $nq = P_2$. Then, $pn = R_2$ and $qn = P_3$. From any pole O , draw the rays On , Op , and Oq , and construct the corresponding equilibrium polygon and bending moment diagram, $DEFG$. The side DG is parallel to the ray On , DE and FG to Op , and EF to Oq .

(e) *Load Overhung*. When, as in Fig. 149, the line of action of the load P does not pass through the centre of gravity of the

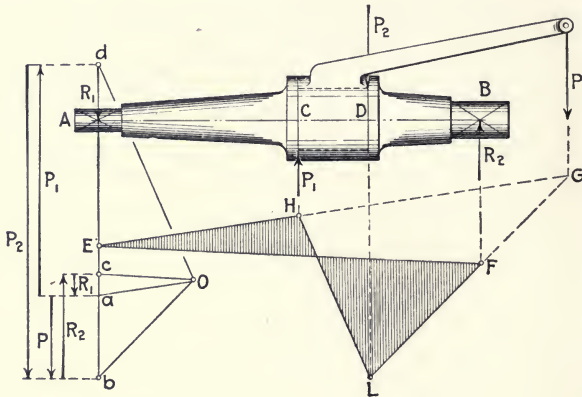

FIG. 149.

bearing area, the leverage of the load causes an upward thrust at one end of the hub-seat and a downward thrust at the other, with also, if the moment be sufficient, reactions which are reversed similarly.

In Fig. 149, draw any triangle, as EFG , with vertices on the lines of action of R_1 , R_2 , and P . This triangle is the equilibrium polygon for these three forces. On the load-line, lay off $ab = P$; from a and b , draw aO and bO , parallel to EG and FG , respectively, and intersecting at the pole O of the force polygon; from O , draw Oc parallel to Ef . Then, $ca = R_1$ and $bc = R_2$. The force P has thus been resolved into two parallel forces (Art. 25) on the same side of P , one with, the other against it.

The force P is also the resultant of the upward thrust P_1 and the downward thrust P_2 at the ends of the hub-seat. The magnitude of these two components of P can be determined by the same method as that just given for R_1 and R_2 . Prolong the line of action of P_1 until it intersects the side EG at H ; similarly, let the line of action of P_2 intersect GF prolonged at L . Connect H and L . Then, the bending moment diagram for the forces R_1 , R_2 , P_1 , and P_2 and the axle is $EHLF$. From O , draw Od parallel to HL . Then, $ad = P_1$ and $db = P_2$, their difference being $P = ab$.

(f) *Multiple-loaded Axles.* If an axle carries two or more loads whose lines of action lie in the same plane, the bending moment diagram for flexure in that plane can be drawn by the methods of Art. 42 (a). When the lines of action are in planes inclined to each other, the moment diagram for bending in any given plane can be constructed as described in Art. 42 (b).

Thus, Fig. 60 shows a vertical force W and a force P , inclined by the angle θ to the vertical, the lines of action of both forces being normal to the axis AB of the axle. With regard to the final reactions, R_1 and R_2 , at the bearings A and B , it should be noted that the partial reaction, due to W at either bearing and as given by the force polygon, lies in a vertical plane, while that due to P is inclined by the angle θ . The final reaction is hence, in magnitude and direction, the resultant of the two partial reactions corresponding with it, when they are inclined to each other by this angle. If the line of action of a force is not perpendicular to the axis, its component normal to the latter should be used in constructing the force and equilibrium polygons.

131. Shafts for Power Transmission. As has been stated, a power shaft is subjected to torsion and also to bending from its own weight, from those of any pulleys, gears, etc., which it may carry, and from the pull of belt-tensions. Each of several such

loads may act to produce bending in a different plane from those of the others.

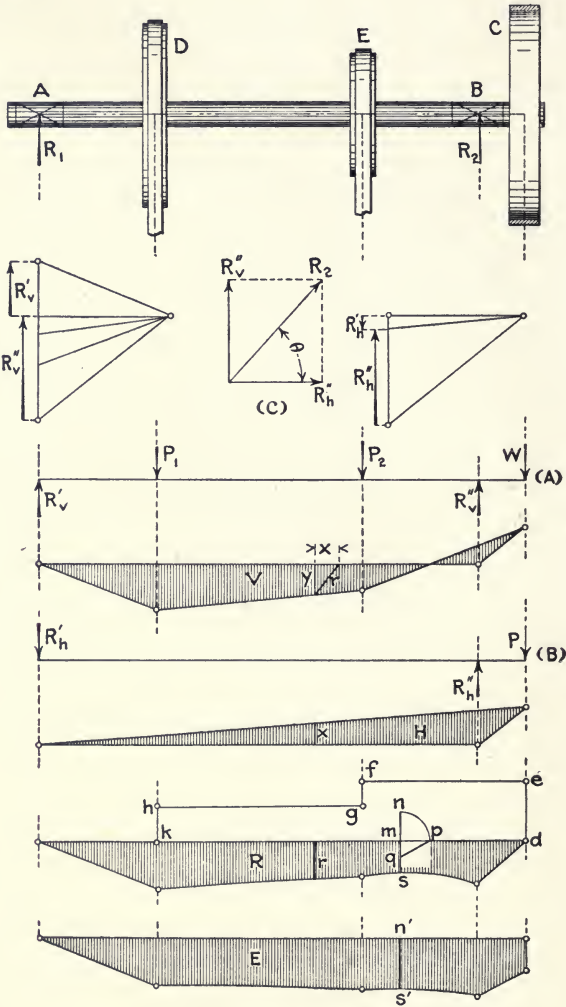

FIG. 150.

Thus, Fig. 150 represents a shaft supported in bearings at *A* and *B*, driven by the pulley *C* to the right of *B*, and driving the pulleys *D* and *E* between the journals. The latter pulleys

are assumed to be belted to others vertically beneath them, while the axis of the driver for C is parallel to, and in the same horizontal plane as, the shaft AB . Therefore, as shown by (A) , the shaft is acted on by the vertical bending forces, P_1 , P_2 , and W , which are, respectively, the weights and belt-tensions of pulleys D and E and the weight W of the pulley C and of one-half of its belt; the corresponding vertical reactions are R_v' and R_v'' . In a horizontal plane, as shown by (B) , the bending force is the resultant P of the belt-tensions of pulley C , the corresponding horizontal reactions being R_h' and R_h'' . The resultants, R_1 and R_2 , of these two sets of reactions are obtained as shown by (C) for B_2 .

The two force polygons are drawn to the same load-scale and with the same pole-distance. The equilibrium polygons V and H are, respectively, the bending-moment diagrams for the vertical and horizontal forces, while polygon R is the combined bending-moment diagram, or the resultant of V and H . To obtain any ordinate, as r , of diagram R , lay off horizontally from, the similar ordinate y of V , the corresponding ordinate x of H ; r is then the resultant of x and y .

The shaft is also subjected to torsion from C to D ; from C to E , the twisting moment is that required to drive both of the pulleys E and D ; between the two latter, the moment is equal to the driving moment for D only. This twisting moment is represented by the diagram $defghk$, the scale being the same as that of the bending moment.

Diagram E gives the equivalent bending moments at all sections of the shaft, *i.e.*, at each section, the bending moment which is equivalent in stress to the aggregate of the three other moments. The method of constructing this diagram is based on equation (2), Art. 50. With any point m on the axis kd as a centre, revolve the torsion semi-ordinate mn to the horizontal at mp ; and from q , the middle point of the corresponding bending ordinate, draw qp . Then, $pq + qs = n's'$, the resultant

shaft, as drawn, is uniform throughout and is equal to $P \times p$, in which p is the effective radius of the crank. The latter is a cantilever, and, as the load P is applied eccentrically, the tendency is not only to bend the crank but to twist it about the neutral axis bc , when the engine is not on either 'dead centre.' The crank pin is also a cantilever, loaded at the middle of its length with P .

The maximum effects in bending and twisting combined are produced when the force P is at right angles with the crank, which is the position shown by full lines in Fig. 152, where Q is the total pressure on the piston, P is the thrust on the crank pin, and R , the resultant of the reactions from the shaft bearings, is equal and parallel to P and opposed to it in direction. To simplify the diagrams of Fig. 151, the forces P

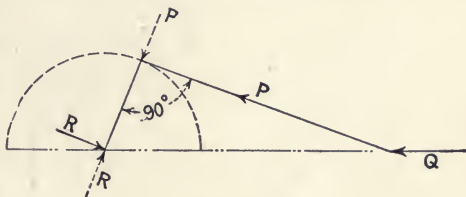

FIG. 152.

and R , with regard to their bending action on the crank pin and the shaft, are assumed to be revolved through 90° , as shown by dotted lines in Fig. 152, and to act in the plane of the crank, this change evidently having no effect on the flexure of these two members. In the bending and twisting of the crank and in the torsion of the shaft, however, P is considered in its original direction.

(a) *Shaft.* Lay off the line $abcd$ representing the neutral axes of the shaft, crank, and crank pin. The forces acting to bend this composite beam are P applied at the centre of the crank pin, and, in the same plane as P , the reactions R_1 and R_2 from the shaft bearings; the magnitude of P is known and those of the reactions are given by the force polygon. The bending moment diagram is aef ; the ordinates of this diagram from f to w are proportional to the moments on the crank pin, the remaining ordinates, from w to a , to the moments on the shaft.

The twisting moment acting on the shaft from b to a is equal to $P \times p$. In the partial force polygon for P , the abscissa p has the ordinate T which, on the same scale as that of the bending-moment diagram, is equal to Pp , since, in the force polygon :

$$T : P :: p : H$$

$$T \times H = Pp,$$

i.e., as T and any ordinate of the bending-moment diagram must each be multiplied by the pole-distance H to obtain the numerical value of the moment, the two ordinates are drawn to the same scale. The rectangle $akmb$ of height T therefore represents the twisting moments on the shaft. The diagram for the equivalent bending moments on the shaft is $ane'qb$; it is drawn by the methods given in Art. 131.

(*b*) *Crank Pin*. The pressure of the connecting rod on the crank pin is assumed to be uniform throughout the length of the pin, and may therefore be considered as concentrated in the force P at the middle. The corresponding bending moments are shown proportionately by the ordinates from f to g in the bending moment diagram. In addition to this bending, there is a cross (vertical) shear at the inner end of the pin, and, when the engine is on either 'dead centre,' flexure of the crank in the plane of the line of action of P .

(*c*) *Crank*. As has been stated, the force P , with regard to the crank, is considered to be at right angles with the latter, as shown in full lines in Fig. 152. The bending moment on the crank is then zero at the outer extremity c and is equal to $P \times p$ at the inner end b . The diagram of bending moments is therefore cbr , in which, on the same scale as that of the previous diagrams, $br = Pp = T$. The bending moment at any section of the crank is equal to the product of the pole-distance H by the length of a line drawn at the given section, parallel to br and extending from cb to cr .

The force P , when at right angles to the crank, also acts to twist the latter on its neutral axis bc with a lever-arm l equal to the distance between the line of action of the force and this neutral axis. The twisting moment is then $P \times l$, which, by the reasoning given previously, is seen to be equal to the ordinate t in the force polygon. This torsional moment is uniform throughout the length of the crank and is represented by the rectangle $bcsv$ of height t . The twisting moment at any section of the crank is therefore the product of H by the length of a line drawn at the section, parallel to cs and between bc and sv . The diagram for the equivalent bending moments on the crank is $cbxy$; it is constructed as described previously.

133. Shaft with Single Crank, Overhung and Offset. The crank shaft shown in Fig. 153 is, with one exception, the same as that of Fig. 151. The bearings of the two shafts are the same distance apart and the cranks have the same effective radius ρ ; but, in this case, the crank is not perpendicular to the shaft, being offset so that its neutral axis makes an angle of 60° with that of the shaft. As before, in examining the bending moments for the shaft and crank pin, the line of action of the load P on the pin is assumed to lie in the plane of the crank, while, with regard to the bending of the crank and the twisting of the latter and of the shaft, P is taken as perpendicular to the crank, as shown by full lines in Fig. 152.

(a) *Shaft and Crank Pin.* The bending-moment diagram for the forces P , R_1 , and R_2 , acting on the shaft and pin, is aef . The portion fgw gives the moments on the crank pin; the part $abhe$ shows the moments on the shaft from a to b ; and the remainder, from bh to gw , the bending of the crank when the force P is in the plane of the latter. The twisting moment on the shaft is $P\rho = T$, as before. The diagram of twisting moments is $akmb$, and that for the equivalent bending moments on the shaft is $ne'qb$.

(b) *Crank.* When the force P is, as drawn, in the plane of the crank, the bending moment on the crank at the inner end of the crank pin is represented by the ordinate wg , and that at the inner end of the crank by $bh = bh'$. From the following, it will be seen that, when the line of action of P is perpendicular

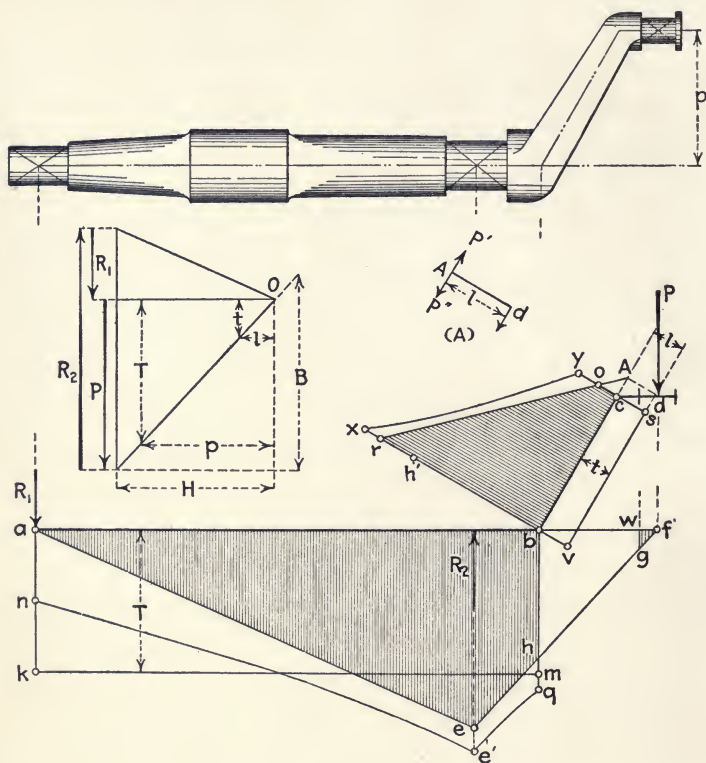

FIG. 153.

to the crank, the bending effect on the crank is materially greater.

Thus, from the centre d of the crank pin, draw the perpendicular $dA = l$ to the neutral axis bc of the crank. The moment of P with regard to that axis is then $P \times l$, and this moment can be resolved into a twisting couple acting on the crank and

a force tending to bend it. As in (*A*), apply at the point *A* the forces P' and P'' , parallel and equal to P and opposed in direction to each other. Then, P' and P form a couple of arm l which twists the crank on its neutral axis, and $P'' = P$ is a force acting at *A* to bend the crank.

The bending moment on the crank is zero at *A* and at *b* is $P \times Ab = B$, whose length is found from the force polygon by the method used for *T*. From *b*, lay off $br = B$ perpendicular to bc , and draw rA ; from *c*, erect the perpendicular co to bc meeting rA at *o*. Then, the diagram of bending moments for the crank is $broc$. Laying off l in the force polygon, we have the twisting moment t , which is uniform throughout the length of the crank. Hence, the diagram of twisting moments is the rectangle $bcsv$ of height t . The ordinates representing the bending and twisting moments are parallel to vr . The diagram for the equivalent bending moments is $bxyc$.

134. Centre-crank Shaft. Figure 154 represents a centre-crank shaft with the crank arms perpendicular to the shaft. No load is shown, the power transmitted through the shaft being assumed to be delivered as a torsional moment at the left-hand end. The friction of the bearings and the weight of the crank shaft are disregarded. As in Art. 132, the force P on the crank pin is treated as lying in the plane of the drawing, so far as the bending of the shaft and crank pin is concerned, and as perpendicular to that plane and to the cranks, with regard to the bending of the latter and the torsion on the shaft, cranks, and pin. The line $abcdef$ represents the neutral axes of these members.

(*a*) *Shaft.* The bending-moment diagram for the forces P , R_1 , and R_2 is afh . The section ef of the shaft acts, through the crank de , simply as a support for the right-hand end of the crank pin, and is therefore not subjected to torsion, but only to the bending whose moments are given by the portion fek of the

diagram. Both bending and twisting occur in the section ab . The moments for the former are shown by the triangle abg ; the twisting moment is $P \times p = T$ (Art. 132), and its diagram is $abmn$. This torsional moment extends also from a to the centre of the hub-seat at the left, but this part of the shaft will not be

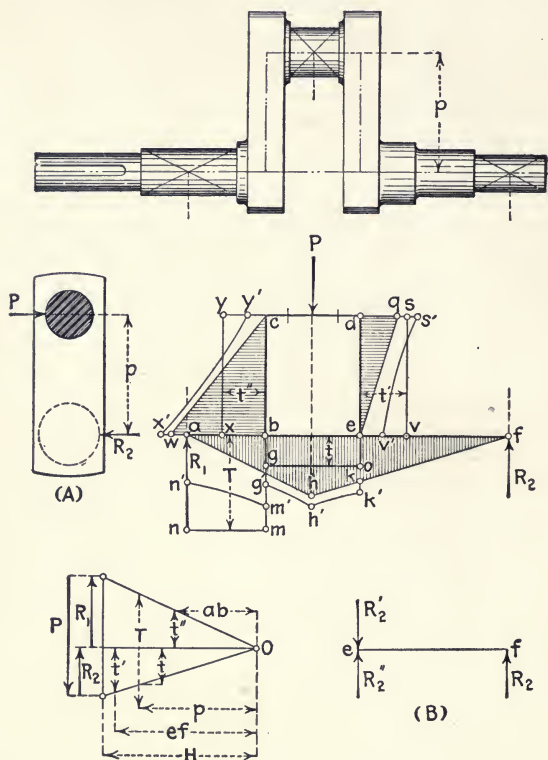

FIG. 154.

considered. The diagram for the equivalent bending moments on the section ab is $an'm'b$.

(b) *Crank Pin.* The bending-moment diagram is $bghke$. The pin is also subjected to torsion from the force R_2 , taken as acting at the point e , as is shown in (A). If, as in (B), there be applied at e two opposite forces R_2' and R_2'' , parallel and equal

to R_2 , no change in the conditions of equilibrium will occur. One of these forces, R_2' , will form with R_2 a couple of arm ef which will twist the crank; the other, R_2'' , will bend the crank and twist the crank pin with the lever-arm p . The twisting moment is $R_2 \times p = t$, the value of t being given by the force polygon. The twisting-moment diagram is the rectangle $bgce$ of height t . The diagram for the equivalent bending moments is $bg'h'k'e$.

In this torsion of the crank pin, the moment t acts against the moment of the forces to the left of it, which may be conceived as momentarily holding the pin stationary while the twisting takes place. Hence, these latter forces should not be considered as producing a similar, but contrary, twisting of the pin.

(c) *Right-hand Crank.* The force R_2 , acting at e , twists the crank pin through the medium of the crank ed as a cantilever fixed at d . Hence, this crank is subjected to bending, the moment at e being zero and that at d being $R_2 \times p = t$. The bending-moment diagram is edq .

The crank is also twisted on its neutral axis de by the force R_2 acting at f with the lever-arm ef . The twisting moment is $R_2 \times ef = t' = ek$, and the moment diagram is the rectangle $edsv$ of height t' . The diagram for the equivalent bending moments on the crank is $eds'v'$.

(d) *Left-hand Crank.* This crank is a cantilever, fixed at b and bent by the force P acting at c . The bending moment is zero at c and $P \times p = T$ at b . The corresponding diagram is cbw .

The crank is twisted on its neutral axis bc by the force R_1 acting at a with a lever-arm ab . The twisting moment is $R_1 \times ab = t'' = bg$, and the moment diagram is the rectangle $bxyc$ of height t'' . The diagram for the equivalent bending moments on the crank is $bx'y'c$.

135. Centre-cranks, Offset. The conditions for the crank shaft shown in Fig. 155 are the same throughout as those for the

shaft examined in Art. 134, except that the cranks are offset, making an angle of 60° with the horizontal, and the shaft bearings are farther apart in consequence. The pressure P on the crank pin is applied as described in Art. 132 and the power

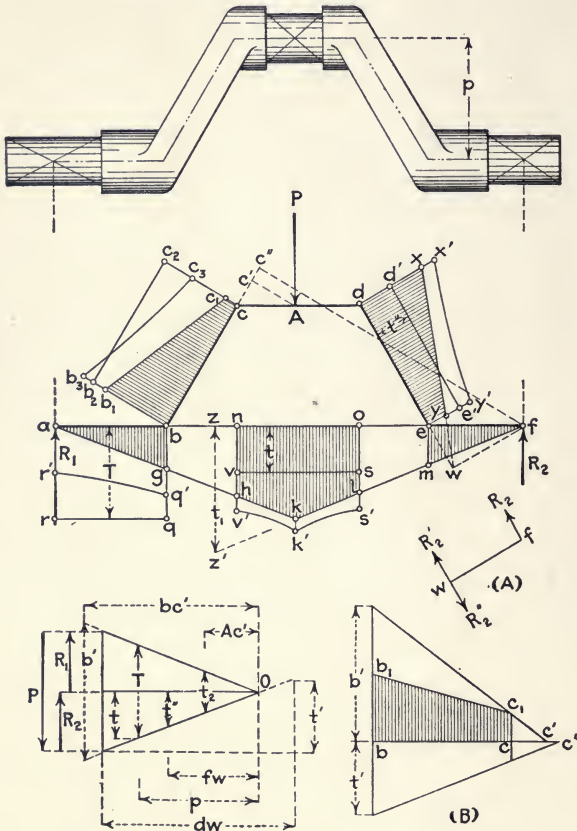

FIG. 155.

transmitted is assumed to be delivered as a torsional moment at the left end of the shaft. The line $abcdef$ represents the neutral axes of the shaft, cranks, and crank pin. The bending-moment diagram for the forces P , R_1 , and R_2 is $ajfk$.

(a) *Shaft.* The section fe is subjected to bending only.

The moment diagram is efm . The section ab is under bending stress as shown by the moment diagram abg ; it is twisted also by the force P with the lever arm p . The twisting moment is $P \times p = T$, the value of T being given by the force polygon (Art. 132). The twisting-moment diagram is the rectangle $abqr$ of height T . The diagram for the equivalent bending moments is $abq'r'$. The twisting moment T also extends through the shaft from a to the centre of the hub-seat on the left, but this section of the shaft will not be considered.

(b) *Crank Pin*. The crank pin is subjected to bending stress from the force P , as shown by the moment diagram $nolkh$. For the reasons given in Art. 134 (b), it is also twisted by the force R_2 , taken as acting at the point o with a lever-arm p . The twisting moment is $R_2 \times p = t$, the value of t being given by the force polygon. The twisting-moment diagram is the rectangle $nosv$ of height t . The diagram for the equivalent bending moments is $nos'k'v'$.

(c) *Right-hand Crank*. Prolong the neutral axis de until it cuts at w the normal to it from the bearing f . Assume, as in (A), two opposite forces, R_2' and R_2'' , each parallel and equal to R_2 , as applied at w . Then the forces R_2 and R_2'' form a couple of arm fw which twists the crank on its neutral axis, and the force R_2' , acting at w , bends the crank, as if the latter were a cantilever of length dw , fixed at d .

The bending moment is zero at w , and at d is $R_2 \times dw = t'$, as given by the force polygon. At d draw the perpendicular $dx = t'$ and connect x and w . The bending-moment diagram is $edxy$. The twisting-moment is $R_2 \times fw = t''$ in the force polygon; the corresponding diagram is $edd'e'$. The diagram for the equivalent bending moments is $edx'y'$.

(d) *Left-hand Crank*. Prolong the neutral axis bc of the crank until it intersects at c' and c'' the perpendiculars drawn from A and f , the points of application of the forces P and R_2 , respectively. Then, applying the principle shown in (A), we

have, at the point c' , a force P acting to drive the crank forward, and, at the point c'' , a force R_2 which resists this motion. Also, by the principle illustrated in (A), the force P , with lever-arm Ac' , tends to bend the crank on its neutral axis in one direction, while the force R_2 , with the lever-arm fc'' , produces torsion in the reverse direction.

Since P and R_2 act to bend the crank in opposite ways, the resultant bending moment is evidently the difference of the moments of these two forces. The moment of P is zero at c' , and at b is equal to $P \times bc' = t'$ in the force polygon. The moment of R_2 is zero at c'' , and at b is equal to $R_2 \times bc''$. As bc'' is equal to $d'w$, the moment of R_2 is equal to t'' , as found previously in the force polygon. Constructing, as in (B), the two bending-moment diagrams, and subtracting the ordinates below the axis bc'' from those above it, we have the diagram bcc_1b_1 for the bending moments on the crank.

Similarly, the twisting moment on the crank is the difference of the moments of R_2 and P . The moment of the former force is $R_2 \times fc''$. From f lay off $fs = fc''$, and the perpendicular $sz' = t_1$ on fk produced, is the moment of R_2 . The moment of P is $P \times Ac' = t_2$, as given by the force polygon. The twisting moment on the crank is, therefore, $t_1 - t_2 = bb_2$, and the moment diagram is bcc_2b_2 . The diagram for the equivalent bending moments is bcc_3b_3 .

136. Double-crank Shaft. Fig. 157 gives the front elevation of a double-crank shaft, the cranks being at right angles and the power being delivered as a twisting moment at the left-hand end of the shaft. The greatest stresses are developed in such a shaft when the cranks are in the position shown in Fig. 156, *i.e.*, the right-hand crank AC — the one farthest from the delivering end of

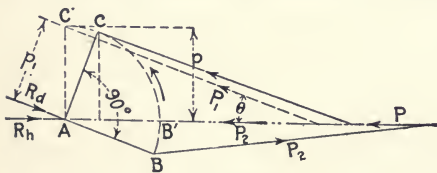

FIG. 156.

the shaft — at right angles with its connecting rod, and the left-hand crank nearly horizontal. If P be the total piston pressure, the thrust P_1 on the crank AC is $\frac{P}{\cos \theta}$ in which θ is the angle of the connecting rod. It will be seen that, when AC becomes vertical, there is but little change in the angle θ . Hence, for simplicity, the cranks will be assumed to be in the positions, AB' and AC' , one horizontal, the other vertical. The direction of the corresponding thrusts, P_2 and P_1 , will then be from right to left, the latter in the inclined plane of its connecting rod, the former horizontal. Each of these thrusts acts, in its plane, to

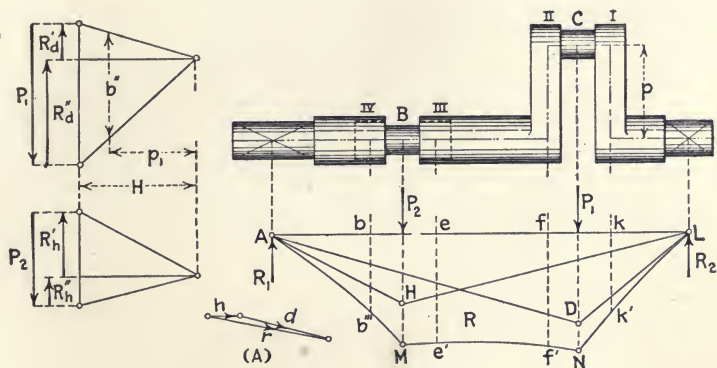

FIG. 157.

bend the crank shaft as a composite beam, and to each there are corresponding reactions in that plane and from the shaft bearings. In Fig. 157 the resultants of these reactions are designated R_d and R_h .

(a) *Bending-moment Diagrams.* These diagrams are superposed in Fig. 157. ADL gives the bending moments in the diagonal plane D due to the force P_1 ; AHL is the similar diagram for the force P_2 which acts in the horizontal plane; and $AMNL$ is the diagram of combined bending moments, whose ordinates are the resultants of those in D and H . The method of constructing the latter diagram is shown at (A). For any

point, as the middle of the crank pin C , the ordinate h from H is laid off horizontally, the similar ordinate d from D follows at the angle θ , and the resultant r of the two is the corresponding ordinate of diagram R , since both force polygons have the same pole distance H . The moments are thus treated as if they were forces. The surface of diagram R does not lie in one plane, but varies in inclination with the relative magnitudes of the corresponding ordinates from D and H . The reaction R_1 is the resultant of R_d' and R_h' ; R_2 is a similar resultant.

(b) *Right-hand Section of Shaft.* The section Lk of the

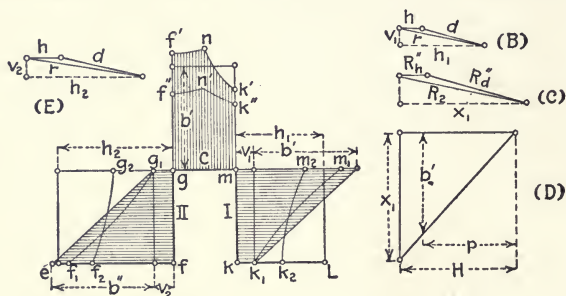

FIG. 158.

shaft is subjected only to the bending shown by the partial bending-moment diagram Lkk' , Fig. 157.

(c) *Crank I.* The line $efgmkL$, Fig. 158, represents the neutral axes of the right-hand crank pin, cranks, and the adjacent sections of the shaft. The plane of these axes is vertical. The right-hand crank, Fig. 154, is subjected to bending and twisting from the action of a single force P . In this case, there are two such forces, P_1 and P_2 , and their combined effect is not only to produce the same bending and twisting in Crank I, but also an additional bending stress in the plane of the crank.

The analysis of the stresses in a multiple-crank shaft is a complex operation. Either of two methods may be followed: the assumption of pairs of equal and opposite forces at any given point, as in Fig. 154 (B); or the treatment of the crank

shaft simply as a beam, in which case there must be considered not only the bending moment at any given point, but also as acting there the algebraic sum of the forces to right or left of it, *i.e.*, a resultant equal to the 'vertical shears' in the plane of the neutral axes of the shaft or in the plane normal to those axes. It should be remembered as to this that, under certain conditions, a bending moment may cause torsion, since fundamentally it is the result of two equal and opposite couples acting at any section to rotate in opposite directions the two parts into which that section divides the beam.

In (*B*), Fig. 158, lay off the bending-moment ordinates h and d from the polygons H and D , respectively, for the point k , the inner end of Crank I. The resultant bending moment r has horizontal and vertical components h_1 and v_1 , respectively. The bending moment h_1 tends to cause rotation of the point k in a horizontal plane, and therefore to twist the crank on its neutral axis km . The twisting-moment diagram is the rectangle of base km and height h_1 . The bending moment v_1 is simply the moment at the section km for bending in a vertical plane of a beam of span AL and depth km at the given section; this moment is uniform at all points in that depth, and the moment diagram is the rectangle of base km and height v_1 .

Regarding the crank as a vertical cantilever fixed at m , it is also subjected to bending in a plane normal to the axis of the shaft by the force equal to the shear acting horizontally at the point k in that plane; this shear is the horizontal component of the reaction R_2 , or x_1 as found in (*C*). The bending moment due to this force is zero at k , and at m is equal to the product of x_1 by $p = km$. In (*D*), lay off x_1 with the pole-distance H , and complete the polygon. Then, the ordinate b' , distant p from the pole, is the bending moment at m . The moment diagram is the triangle of base equal to km and of altitude b' . The two bending moments are perpendicular to each other, and are combined for any given point by using the hypotenuse of the right

triangle which they form as the resultant moment. The diagram of combined bending moments is thus kmm_1k_1 . Combining (Art. 131) this with the twisting-moment diagram, we have kmm_2k_2 as the diagram for the equivalent bending moments on the crank.

(d) *Crank Pin C.* This crank pin is subjected to bending, as shown by diagram R , Fig. 157. The partial diagram giving its moments is transferred to Fig. 158 as $gf'nk'm$. The pin is also subjected to torsion by the force equal to x_1 acting at k with the lever-arm p , the moment, as found previously, being b' . The twisting-moment diagram is therefore the rectangle of base gm and height b' . The diagram for the equivalent bending moments is $gf'n'k'm$.

(e) *Crank II.* The method of analysis is the same as with Crank I. The ordinate polygon (E) gives the horizontal and vertical components, h_2 and v_2 , respectively, of the bending moment at the inner end f of the crank, as shown by diagrams H , D , and R , Fig. 157. The horizontal moment h_2 twists the crank on its neutral axis fg ; the moment diagram is the rectangle of base fg and height h_2 . The moment v_2 is the bending moment on the crank in a vertical plane, the diagram being the rectangle of base fg and height v_2 . The crank is a vertical cantilever held at f by the resultant there of the forces acting on the axis, and having the force P_1 applied at g . This force acts in the plane of the connecting rod at the angle θ with the horizontal. From Fig. 156, the twisting moment on the shaft, and hence the bending moment at the point f , is:

$$M_t = P_1 \times p_1 = (P/\cos \theta) (p \cos \theta) = Pp,$$

in which P is the pressure on the piston and p_1 is the normal from A to the line of action of P_1 . Therefore, in the upper force polygon, Fig. 157, lay off p_1 and the corresponding ordinate, $b'' = P_1 \times p_1 = Pp$. At the point g , the moment is zero. The bending-moment diagram is the triangle of base equal to fg and of altitude b'' . Combining the two perpendicular bend-

ing moments, we have the final bending-moment diagram fgg_1f_1 . This combined with the twisting-moment diagram gives the diagram fgg_2f_2 for the equivalent bending moments on the crank.

(f) *Middle Section of Shaft.* This is subjected to bending, as shown by the partial diagram $eff'e'$, Fig. 157. Its twisting moment is that produced by Crank II, or $P_1 \times p_1 = b''$. The diagram of twisting moments is therefore a rectangle of base ef and height b'' . The two diagrams, when combined (Art. 131), give the equivalent bending moments on this section of the shaft.

(g) *Crank III.* The line $Abcdee_1$, Fig. 159, represents the neutral axes of the crank pin B and the adjacent cranks and shaft sections, all in the horizontal plane. The ordinate poly-

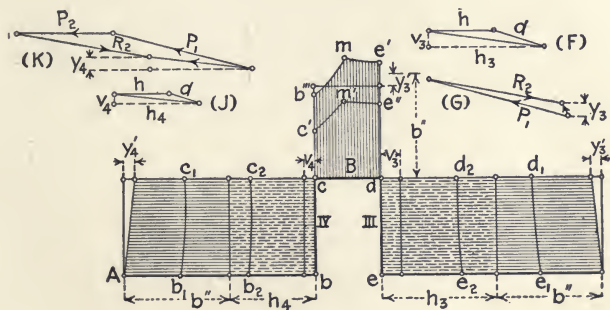

FIG. 159.

gon (F) gives, as before, the horizontal and vertical components of the bending moment at e , the inner end of Crank III. The polygon (G) shows the resultant of R_2 and P_1 , the forces acting to the right of the point e . The vertical component, y_3 , of this resultant is a bending force at e . Crank III is subject to:

Twisting by the vertical component, v_3 , of the bending moment at e which tends to rotate the section at e in a vertical plane, and therefore to twist the crank on its neutral axis ed . The moment diagram is the rectangle of base de and height v_3 .

Vertical Bending from two causes: First, the twisting moment, $Pp = b''$ on the middle section ef of the shaft, is transferred, unchanged in value, to a twisting moment on the crank pin cd . There are thus moments of equal value at the points e and d , and the twisting moment b'' acts, in passing through the crank, as a uniform vertical bending moment on the latter. The moment diagram is the rectangle of base de and height b'' . Second, the vertical component, y_3 , of the forces P_1 and R_2 , to the right of the point e , acts at that point as a vertical bending force on the crank considered as a cantilever fixed at d . The moment of y_3 is zero at e , and at d is equal to $y_3 \times p = y_3'$, whose value is found by the method used in (D), Fig. 158. The direction of the vertical force y_3 at e is upward. Hence, that of its reaction at d is downward, *i.e.*, tending to reverse the engine. As the twisting moment $Pp = b''$ acts to drive the shaft forward, the uniform vertical bending moment which it produces on the crank must have the opposite sign to that developed by the force y_3 . Hence, the resultant bending moment is the difference of the two, and the area of the triangle of base equal to de and altitude y_3' is deducted from that of the rectangle of the same base and the height b'' , the remainder being the diagram for the vertical bending moments.

Horizontal Bending. The horizontal component h_3 of the bending moment at e causes bending in a horizontal plane, as if the shaft were a beam of span AL and of depth de at e . The moment is therefore uniform throughout de , and its diagram is the rectangle of base de and height h_3 .

Combined Diagrams. The diagrams for horizontal and vertical bending give, when combined, the final bending-moment diagram, dee_1d_1 . Combining this with the twisting-moment diagram, we have the diagram dec_2d_2 for the equivalent bending moments on the crank.

(h) *Crank Pin B.* The bending moments on this crank pin are represented by the diagram $cb'''me'$, transferred from dia-

gram R , Fig. 157. The pin is twisted in the direction for forward motion by the twisting moment $Pp = b''$, transmitted from the middle section of the shaft; torsion in the reverse direction is produced by the moment y_3' at d on the crank de , due to the forces to the right of e , as explained previously. The twisting-moment diagram is therefore the rectangle of base cd and height $b'' - y_3'$. The diagram for the equivalent bending moments is $cc'm'e''d$.

(i) *Crank IV.* The ordinate polygon (J) gives the horizontal and vertical components, h_4 and v_4 , respectively, of the bending moment at b , the inner end of the crank. From polygon (K), there is found the vertical component, y_4 , of the forces acting to the right of the point b .

The analysis of the stresses is the same as that for Crank III, except that the forces and moments are now considered at the point b . The twisting moment on the crank is the vertical component, v_4 , of the bending moment at b ; the horizontal component, h_4 , of this moment bends the crank in a horizontal plane with a uniform moment throughout; there are, as before, two opposite bending moments in the vertical plane, $Pp = b''$ (uniform) in one direction and y_4' at C , this being the moment of y_4 which is assumed as acting at b . The diagram of combined bending moments is bb_1c_1c , and that of the equivalent bending moments, bb_2c_2c .

(j) *Left-hand Section of Shaft.* The bending moments acting on the section Ab of the shaft are shown by the partial diagram Abb''' , Fig. 157. The twisting moment is that produced by the crank C , or $Pp = b''$. From these data, the equivalent bending moments can be found.

(k) *Maximum Stresses.* The position of the cranks which is assumed in Figs. 156 to 159, inclusive, is that which will produce the maximum bending moments in the entire shaft and the greatest twisting moment on the middle section ef . Maximum torsion occurs in the section ab or power-delivering end when

each crank makes an angle of 45° with the centre-line of the engine. From Figs. 158 and 159, it will be seen that the equivalent bending stress in the four cranks is the greatest in Crank II at the inner or shaft end, and in Crank III at the outer end.

When a crank shaft of this type is of moderate or large size, it is necessary to have a bearing between the two pairs of cranks, in order to reduce the bending stresses. In such cases, the shaft should be treated as a continuous beam, having three supports, all on one level. The method of analysis is the same as that which has been followed herein, except that there is an additional force, in a third reaction from the middle bearing, to be considered.

PROBLEMS

102. A shaft is driven by two-to-one bevel gears located between the bearings; it carries a driven pulley at one end, outside the bearing. Find the bending and twisting stresses.

103. A shaft, carrying a fly-wheel between the bearings, is driven by two overhanging cranks, one at each end and at right angles to each other. Find the stresses.

104. Find the stresses in the 'Return Crank.'

105. Find the stresses in the driving axle of a locomotive (outside cylinders).

106. Find the bending stresses in the crank shaft, Fig. 157, when there is a middle bearing between the two cranks.

107. Find the stresses in a triple-crank shaft, cranks at 120° .

108. Find graphically a method of counterbalancing the centrifugal forces of a crank shaft having two cranks at right angles with each other.

INDEX

Addition, graphic	3, 28
Angle of friction	232
of torsion	273
Apex	156
Arc, centre of gravity of	53
Area, centre of gravity of, compound	58
curvilinear	57
irregular	61
partial	60
polygonal	55
Area, measurement of, curvilinear	20
polygonal	17
quadrilateral	16
triangular	15
Area, moment of	75
moment of inertia of	81, 88
n th moment of	91
Arithmetic, graphic	2
Axis, neutral	116
Axles, inclined loads	279
loads parallel to axis	281
multiple loads	283
normal loads	277, 278, 282
Beams	100
cantilever	100, 125, 170, 176
overhanging	132
reactions	102, 144
restrained	132
Belt friction	255
Bending moments	70, 72, 109, 112, 117, 124, 126, 197
and chord stress	190
and shearing force	112, 117, 124
combined	72
influence diagrams	135-139
maximum	114, 204
scale	66
Bending and twisting combined	95, 275
Bowstring truss	187
Bridge trusses	176
loads	178
weights	178

Camber	177
Cantilever beams	100, 125, 170, 176
braced	170
Centre of gravity	50, 53, 75
area	55-61, 75
line	53
Centre of gyration	79
Centroid	50
Chain friction	250
Character of stresses	32, 148, 198
Chords	147
increment	191, 193
stress and bending moment	190
stresses	190, 197, 216, 221
Coefficients of elasticity	102, 271
friction	231
Collar friction	243
Combined bending moments	72
Complanar forces, equilibrium	37
moment of	69
moment of inertia	83
Composition of forces	24, 43
Compression, laws of	101
Cone, friction	233
Conical pivots, friction	241
Cord polygon	32
Cotterill	124, 256
Counter-bracing	147, 203
Couples	24, 47
moment of	68
Cranes	173
Cranks, centre	291, 293
double	296
overhung	286
overhung, offset	289
Cremona	18
Crescent truss	155
Culmann	21
Curve, deflection	124, 129, 132
deflection and slope	124
elastic	119
load, shear, and bending moment	124
Dead-load stresses	157, 180, 195
Deck span	177
Deflection curve	124, 129, 132
Depth of truss	176
Diagonals, stresses in	181, 185, 192, 197, 208, 218, 223
Division, graphic	5
Duchemin's formula	161

Efficiency of mechanism	229
Elastic curve	119
limit	102
Elasticity	102
coefficients of	102, 271
modulus of	102
Equiangular spiral	11
Equilibrium polygon	32
Equilibrium, conditions of	34, 37, 41, 70, 115, 153
kinetic	1
of coplanar forces	37
of jointed frame	31
of parallel forces	41
static	1
Eytelwein's formula	252
Falk	134
Force	1
moment of	63, 65, 67, 69, 75
Force polygon	27, 40, 195, 224
Force triangle	26-29
Forces, composition and resolution	24, 43
non-concurrent	29, 35, 37
parallel	40-47, 83
parallelogram of	24
parallel, moment of inertia	83
Framed structures, assumptions	146
Friction	230
circle	246
coefficient of	231
cone	233
examples	261
laws of sliding	231
mean radius of	242
of motion	230
of rest	230
rolling	260
Friction of plane surfaces	233
belts	255
chains	250
collar bearing	243
journals	244
link connections	247
pivots	239
ropes	251
screw threads	236
spur-gear teeth	253
wedge	234
Funicular polygon	32

Girders, plate	205, 224
Goodman	124
Grashof	96
Gravity, centre of	50, 53, 75
Gyration, centre of	79
radius of	78
Hermann	263, 267
Higher moment surface	91
Howe truss	183, 192, 196
Hutton's formula	161
Impact	179
Inclined chords	221
Incomplete structure	148
Inertia, parallel axes of	80
polar moment of	93
rectangular moment of	78
Influence diagrams	134-145
Internal stresses	114
Intersections	189
Jointed frame, equilibrium of	31
Journal friction	244
Kennedy	231, 267
Key, friction of	234
Lateral bracing	177
Lattice girders	177, 189
Lenticular truss	189
Limit, elastic	102
Line, centre of gravity of	53
Lineham	124
Link connections, friction of	247
Live load shear	198
Load curve	124
Loads, bridge trusses	178
roof trusses	154
wind	161
Locomotive wheel loads	215
Logarithmic spiral	12
Lost work	228
Maximum and minimum stresses	167
moments	114, 204
shear	198
Maxwell, Clerk	150
Mechanism, efficiency of	229
Merriman	96
and Jacoby	178, 200

Method of sections	153
substitution	169
Modulus of elasticity	102
section	119
Moment diagrams, shafting	228
Moment	63
of force	63-69, 75
area	75
couple	68
non-parallel forces	65
parallel forces	67
Moment of inertia, polar	93
rectangular	78
Moment-surfaces, higher	91
Moment, resisting	116
twisting	93
Moments, bending	70, 72, 109, 112, 117, 124, 126, 197
combined	72
scale	66
Moments combined, bending and twisting	95, 275
Neutral axis	116
surface	116
Non-concurrent forces, force polygon	29
resultant	35
Non-parallel forces, moment	65
Overhanging beams, deflection curves	132
Panel-point	156
Parallel forces	40-47
composition and resolution	43
equilibrium of	41
force polygon	40
moments	67
moment of inertia	83
Parallelogram, centre of gravity of	56
Parallelogram of forces	24
Pivots, friction of	239
Plane surfaces, friction of	233
Plate girders	205, 224
Polar moment of inertia	93
Polygon, equilibrium	32
force	27-29, 40, 195, 224
spiral	8
Powers	7
Pratt truss	187, 189, 192, 195, 203, 210
Radius of friction	242
gyration	78

Rafters	155, 156
Rankine	95, 153, 245
Reactions	102
influence diagrams	144
Reciprocal diagrams	150
Redundant members	147
Resisting moment	116
Resolution of forces	24, 43
Restrained beams	100
deflection curve	132
Resultant, moment of	69
non-concurrent forces	35
Reuleaux	8
Rigid body	1
Rise, roof truss	155
Rolling friction	260
Roof covering, weights	156
Roof trusses	146
loads	154
notation	148
weight	156
Roots	10
Rope, friction of	251
Scale, moment	66
Screw threads, friction of	236
Section, modulus of	119
Sections, method of	153
Sector, area of	20
Segment, area of	20
centre of gravity of	57
Set, permanent	102
Shafts, crank	286-304
for power transmission	283
hollow	275
Shafting, moment diagrams for	269
Shear and bending moment	112, 117, 124
and resultant stresses	270
curves of	124
horizontal	271
influence diagrams for	139-144
live load	198
resisting	115
vertical	104, 106, 112, 191, 198
Shearing, coefficient of elasticity for	271
Similar triangles	3
Simple beams	100
Sliding friction, laws of	231
Slope, curves of	124

Snow load	157, 180
Span	147
Spiral, equiangular	11
logarithmic	12
polygon	8
Spur-gear teeth, friction of	253
Square threads, friction of	237
Statics	1
graphic	2
Stiffness	133
Stress curves	128
Stress diagrams	150
Stresses, internal	101, 114
Substitution, method of	169
Subtraction, graphic	3
Surface, neutral	116
Surfaces, moment	91
Strut	147
Sway bracing	177
Tension, laws of	101
Through span	177
Thurston	267
Tie	147
rod	155
Torsion	93, 271
and bending combined	95, 275
Total work	228
Trautwine	156, 178
Triangle, centre of gravity	55
force	26-29
Triangular threads, friction of	239
Trusses, bridge	176
roof	146
Twisting and bending combined	95, 275
moment	93
Uniform live load	179
stresses	180
Useful work	228
Vector polygon	27
Vertical shear	104, 106, 112, 191, 198
and bending moment	112, 117, 124
Verticals, stresses in	191, 194, 198, 211, 213, 219, 223
Von Ott	8
Waddell	179
Warren truss	181, 208
Web members	147
stresses	191, 207

Wedge, friction of	234
Weights, bridge trusses	178
roof trusses	156
Weisbach	252, 267
Whipple truss	189
Wind load	161, 179
stresses	162-164
pressure	161
Work — useful, lost, total	228

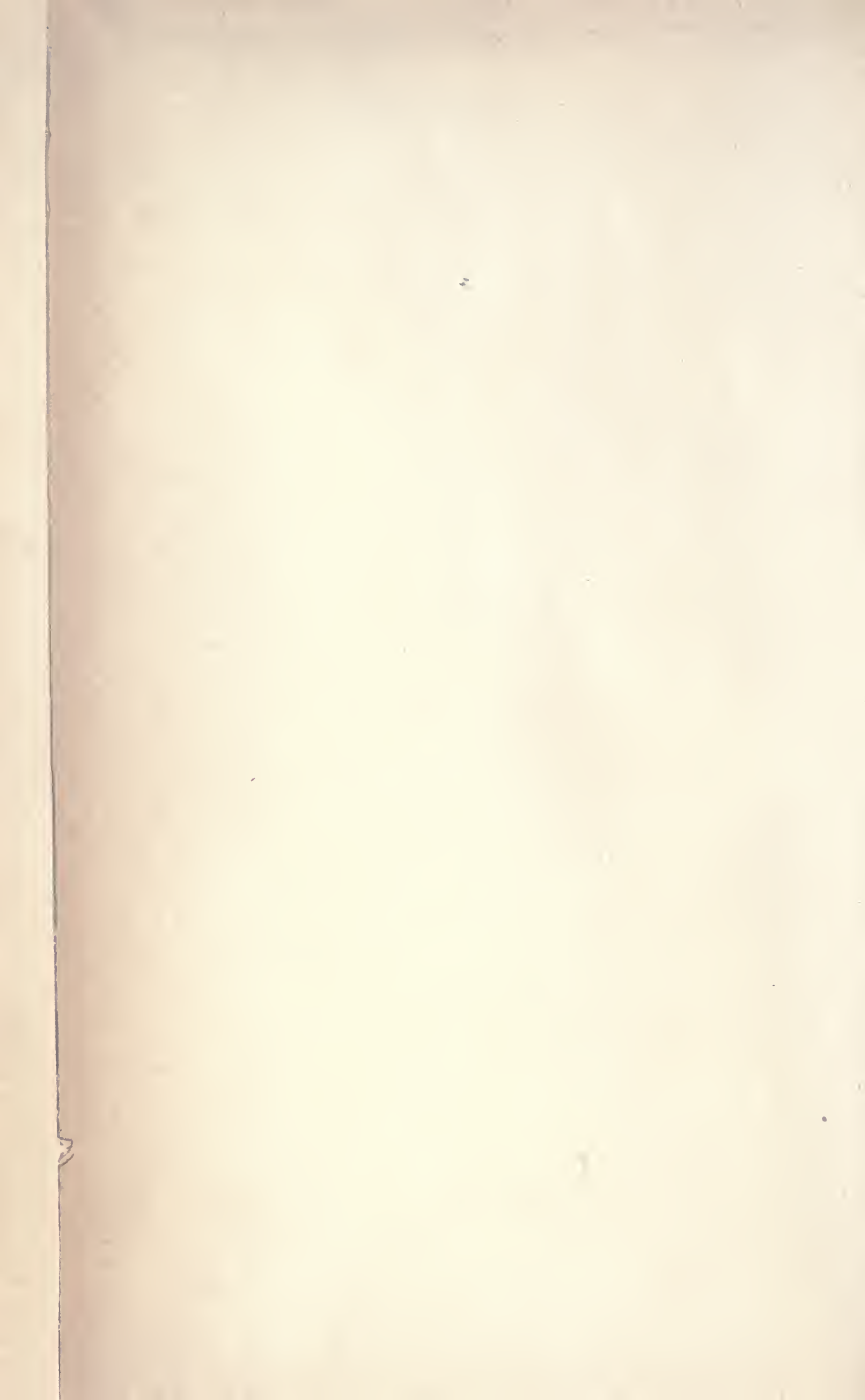

235521

TG 270

C 3

UNIVERSITY OF CALIFORNIA LIBRARY

