







**ELEMENTS OF HYDRAULICS**

# McGraw-Hill Book Company

*Publishers of Books for*

Electrical World	The Engineering and Mining Journal
Engineering Record	Engineering News
Railway Age Gazette	American Machinist
Signal Engineer	American Engineer
Electric Railway Journal	Coal Age
Metallurgical and Chemical Engineering	Power





Lock and dry dock of the Mississippi River Power Company at Keokuk, Iowa, the greatest hydraulic development in the world. (See Problems 36-39).  
*Frontispiece.*

# ELEMENTS OF HYDRAULICS

BY

S. E. SLOCUM, B. E., PH. D.,  
PROFESSOR OF APPLIED MATHEMATICS IN THE  
UNIVERSITY OF CINCINNATI

FIRST EDITION



McGRAW-HILL BOOK COMPANY, INC.  
239 WEST 39TH STREET, NEW YORK  
6 BOUVERIE STREET, LONDON, E. C.

1915

TC160  
S4

COPYRIGHT, 1915, BY THE  
MCGRAW-HILL BOOK COMPANY, INC.

TO WHOM  
APPROPRIATE

THE MAPLE PRESS YORK PA

## PREFACE

THE remarkable impetus recently given to hydraulic development in this country has caused the whole subject to assume a new aspect. Not only is this apparent in new and improved construction details, but in the scientific study which is beginning to be given a subject which seemed to have crystallized into a set of empirical formulas.

Such comprehensive plans as those recently undertaken by the State of New York and the Dominion of Canada for the systematic development of all their available water power, indicates the extent of the field now opening to the hydraulic engineer. The extent and cheapness of the natural power obtained not only from the development of existing streams but also from the artificial pondage of storm water is sufficient to convince even the most casual observer that no phase of conservation will have a more immediate effect on our industrial development or be more far reaching in its consequences.

The present text is intended to be a modern presentation of the fundamental principles of hydraulics, with applications to recent important works such as the Catskill aqueduct, the New York State barge canal, and the power plants at Niagara Falls and Keokuk. Although the text stops short of turbine design, the recent work of Zowski and of Baashuus is so presented as to enable the young engineer to make an intelligent choice of the type of development and selection of runner.

In order to make the book of practical working value, a collection of typical modern problems is added at the end of each section, and a set of the most useful hydraulic data has been compiled and is tabulated at the end of the volume.

S. E. SLOCUM.

CINCINNATI, OHIO,  
*January, 1915.*

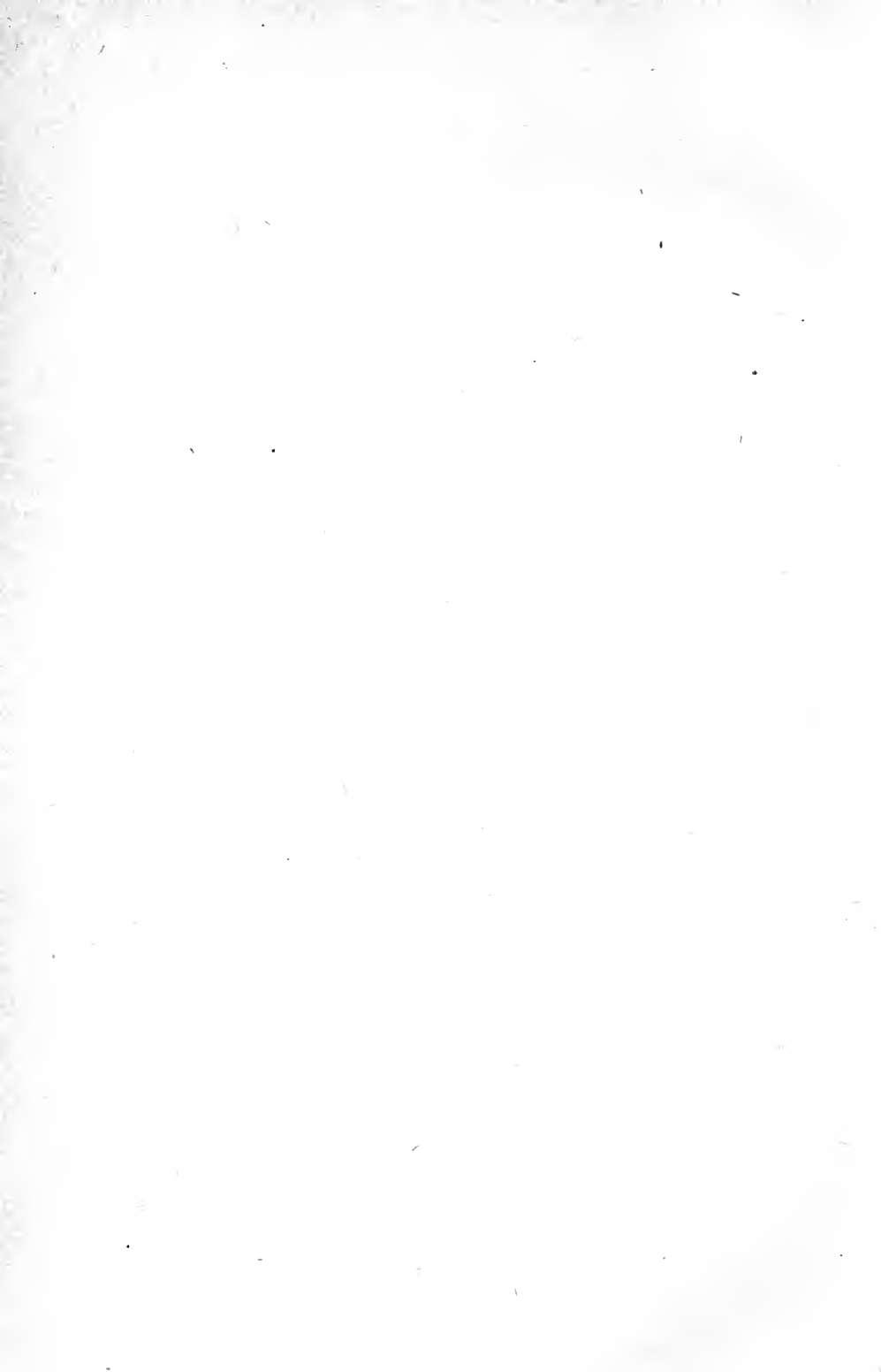



# CONTENTS

	PAGE
PREFACE . . . . .	V

## SECTION I

### HYDROSTATICS

ART. 1. PROPERTIES OF A PERFECT FLUID . . . . .	1
Definition—Distinction between liquid and gas—Elasticity of water—Fluid pressure normal to surface—Viscosity—Density of water—Specific weight.	
2. HYDROSTATIC PRESSURE . . . . .	3
Equal transmission of pressure—Pressure proportional to area—Hydraulic press—Frictional resistance of packing—Efficiency of hydraulic press.	
3. SIMPLE PRESSURE MACHINES . . . . .	8
Hydraulic intensifier—Hydraulic accumulator—Hydraulic jack—Hydraulic crane—Hydraulic elevator.	
4. PRESSURE ON SUBMERGED SURFACES . . . . .	12
Change of pressure with depth—Pressure on submerged area—Center of pressure—General formula for center of pressure—Application.	
5. EQUILIBRIUM OF TWO FLUIDS IN CONTACT . . . . .	16
Head inversely proportional to specific weight—Water barometer—Mercury barometer—Piezometer—Mercury pressure gage.	
6. EQUILIBRIUM OF FLOATING BODIES . . . . .	20
Buoyancy—Floating equilibrium—Theorem of Archimedes—Physical definition of specific weight—Determination of specific weight by experiment—Application to alloy—Zero buoyancy.	
7. METACENTER. . . . .	23
Stability of floating body—Metacenter—Coordinates of metacenter—Metacentric height—Period of oscillation—Rolling and pitching.	
APPLICATIONS . . . . .	28

## SECTION II

### HYDROKINETICS

ART. 8. FLOW OF WATER FROM RESERVOIRS AND TANKS. . . . .	44
Stream line—Ideal velocity head—Torricelli's theorem—Actual velocity of flow—Contraction coefficient—Efflux	

ART.	PAGE
	coefficient—Effective head—Discharge from large rectangular orifice—Discharge of a rectangular notch weir.
9. DISCHARGE THROUGH SHARP-EDGED ORIFICE . . . . .	48
	Contraction of jet—Complete contraction—Partial contraction—Velocity of approach.
10. RECTANGULAR NOTCH WEIRS . . . . .	51
	Contracted weir—Suppressed weir—Empirical weir formulas—Rational weir formula.
11. STANDARD WEIR MEASUREMENTS . . . . .	53
	Construction of weir—Hook gage—Location of hook gage—Proportioning of weirs.
12. TIME REQUIRED FOR FILLING AND EMPTYING TANKS. . . . .	56
	Change in level under constant head—Varying head—Canal lock—Rise and fall in connected tanks—Mariotte's flask.
13. FLOW THROUGH SHORT TUBES AND NOZZLES . . . . .	60
	Standard mouthpiece—Stream line mouthpiece—Borda mouthpiece—Diverging conical mouthpiece—Venturi adjunctage—Converging conical mouthpiece—Fire nozzles.
14. KINETIC PRESSURE IN A FLOWING LIQUID . . . . .	64
	Kinetic pressure—Bernoulli's theorem—Kinetic pressure head—Application to standard mouthpiece.
15. VENTURI METER . . . . .	67
	Principle of operation—Formula for flow—Commercial meter—Catskill aqueduct meter—Rate of flow controller.
16. FLOW OF WATER IN PIPES . . . . .	71
	Critical velocity—Viscosity coefficient—Parallel (non-sinusoidal) flow—Average velocity of flow in small pipes—Loss of head in small pipes—Ordinary pipe flow.
17. PRACTICAL FORMULAS FOR LOSS OF HEAD IN PIPE FLOW . . . . .	76
	Effective and lost head—Friction loss—Bends and elbows—Enlargement of section—Contraction of section—Gate valve in circular pipe—Cock in circular pipe—Throttle valve in circular pipe—Summary of losses—Application.
18. HYDRAULIC GRADIENT . . . . .	82
	Kinetic pressure head—Slope of hydraulic gradient—Peaks above hydraulic gradient.
19. HYDRAULIC RADIUS . . . . .	84
	Definition—Chezy's formula.
20. DIVIDED FLOW . . . . .	86
	Compound pipes—Branching pipes.
21. FIRE STREAMS . . . . .	89
	Freeman's experiments—Formulas for discharge—Height of effective fire stream.
22. EXPERIMENTS ON THE FLOW OF WATER . . . . .	90
	Verification of theory by experiment—Method of conducting experiments—Effect of sudden contraction or enlarge-

ART.		PAGE
	ment—Disturbance produced by obstacle in current— Stream line motion in thin film—Cylinder and flat plate— Velocity and pressure.	
23.	MODERN SIPHONS . . . . .	95
	Principle of operation—Siphon spillway—Siphon lock.	
24.	FLOW IN OPEN CHANNELS . . . . .	100
	Open and closed conduits—Steady uniform flow—Kutter's formula—Limitations to Kutter's formula—Bazin's for- mula—Kutter's simplified formula.	
25.	CHANNEL CROSS SECTION . . . . .	103
	Condition for maximum discharge—Maximum hydraulic efficiency—Regular circumscribed polygon—Properties of circular and oval sections.	
26.	FLOW IN NATURAL CHANNELS . . . . .	106
	Stream gaging—Current meter measurements—Float measurements—Variation of velocity with depth—Calcu- lation of discharge.	
27.	THE PITOT TUBE . . . . .	109
	Description of instrument—Darcy's modification of Pitot's tube—Pitometer—Pitot recorders—Theory of the impact tube—Construction and calibration of Pitot tubes— DuBuat's paradox.	
28.	NON-UNIFORM FLOW—BACKWATER . . . . .	118
	Energy equation for stream of variable depth—Differential equation of surface profile—Backwater curve for broad shallow stream—Integration of backwater function— Values of integral—Condition for singularities in back- water curve—Numerical application.	
	APPLICATIONS . . . . .	126

## SECTION III

## HYDRODYNAMICS

ART. 29.	PRESSURE OF JET AGAINST STATIONARY DEFLECTING SURFACE	144
	Normal impact on plane surface—Relation of static to dynamic pressure—Oblique impact on plane surface— Axial impact on surface of revolution—Complete reversal of jet—Deflection of jet—Dynamic pressure in pipe bends and elbows.	
30.	PRESSURE EXERTED BY JET ON MOVING VANE . . . . .	149
	Relative velocity of jet and vane—Work done on moving vane—Speed at which work becomes a maximum—Maximum efficiency for single vane—Maximum efficiency for con- tinuous succession of vanes—Impulse wheel, direction of vanes at entrance and exit—Work absorbed by impulse wheel.	
31.	REACTION OF A JET . . . . .	154

ART.	PAGE
	Effect of issuing jet on equilibrium of tank—Energy of flow absorbed by work on tank—Principle of reaction turbine—Barker's mill.
32. TYPES OF HYDRAULIC MOTORS . . . . .	156
	Current wheels—Impulse wheels—Reaction turbines—Classification of reaction turbines—Classification of hydraulic motors.
33. CURRENT AND GRAVITY WHEELS . . . . .	158
	Current wheels—Undershot wheels—Poncelet wheels—Breast wheels—Overshot wheels.
34. IMPULSE WHEELS AND TURBINES. . . . .	159
	Pelton wheel—Efficiency of Pelton wheel—Girard impulse turbine—Power and efficiency of Girard turbine.
35. REACTION TURBINES. . . . .	169
	Historical development—Mixed flow or American type—Use of draft tube—Recent practice in turbine setting.
36. CHARACTERISTICS OF IMPULSE WHEELS AND REACTION TURBINES . . . . .	181
	Selection of type—Action and reaction wheels—Speed criterion—Capacity criterion—Characteristic speed—Specific discharge—Specific power—Specific speed—Relation between characteristic speed and specific speed—Classification of reaction turbines—Classification of impulse wheels—Numerical applications—Normal operating range—Selection of stock runner.
37. POWER TRANSMITTED THROUGH PIPE LINE AND NOZZLE . . . . .	195
	Effective head at nozzle—Velocity of flow for maximum power—Maximum efficiency—Diameter of nozzle for maximum output of power—Graphical relation between power and efficiency—Method of determining nozzle diameter.
38. EFFECT OF TRANSLATION AND ROTATION . . . . .	198
	Equilibrium under horizontal linear acceleration—Equilibrium under vertical linear acceleration—Free surface of liquid in rotation—Depression of cup below original level in open vessel—Depression of cup below original level in closed vessel—Practical applications.
39. WATER HAMMER IN PIPES . . . . .	202
	Increase in pressure due to suddenly checking flow—Bulk modulus of elasticity of water—Pressure waves in pipe produced by suddenly checking flow—Velocity of compression wave—Period of compression wave—Increase in pressure produced by instantaneous stoppage of flow—Joukovsky's experiments—Gibson's experiments.
40. HYDRAULIC RAM . . . . .	205
	Principle of operation—Efficiency of ram.

ART.	PAGE
41. DISPLACEMENT PUMPS . . . . .	207
Suction pump—Maximum suction lift—Force pump— Stress in pump rod—Direct driven steam pump—Calcula- tion of pump sizes—Power required for operation—Diam- eter of pump cylinder.	
42. CENTRIFUGAL PUMPS . . . . .	215
Historical development—Principle of operation—Impeller types—Conversion of kinetic energy into pressure—Volute casing—Vortex chamber—Diffusion vanes—Stage pumps.	
43. PRESSURE DEVELOPED IN CENTRIFUGAL PUMP . . . . .	224
Pressure developed in impeller—Pressure developed in diffusor—General formula for pressure head developed.	
44. CENTRIFUGAL PUMP CHARACTERISTICS . . . . .	227
Effect of impeller design on operation—Rising and droop- ing characteristics—Head developed by pump—Effect of throttling the discharge—Numerical illustration.	
45. EFFICIENCY AND DESIGN OF CENTRIFUGAL PUMPS. . . . .	234
Essential features of design—Hydraulic and commercial efficiency.	
46. CENTRIFUGAL PUMP APPLICATIONS . . . . .	236
Floating dry docks—Deep wells—Mine drainage—Fire pumps—Hydraulic dredging—Hydraulic mining.	
APPLICATIONS . . . . .	242

SECTION IV

HYDRAULIC DATA AND TABLES

TABLE 1. Properties of water . . . . .	260
2. Head and pressure equivalents . . . . .	261
3. Discharge equivalents. . . . .	262
4. Weights and measures . . . . .	263
5. Specific weights of various substances. . . . .	264
6. Dimensions of steam, gas, and water pipe . . . . .	265
7. Capacity of reciprocating pumps . . . . .	266
8. Circumferences and areas of circles . . . . .	268
9. Efflux coefficients for circular orifice . . . . .	273
10. Efflux coefficients for square orifice . . . . .	272
11. Fire streams . . . . .	275
12. Coefficients of pipe friction . . . . .	277
13. Friction head in pipes. . . . .	278
14. Bazin's values of Chezy's coefficient . . . . .	282
15. Kutter's values of Chezy's coefficient . . . . .	283
16. Discharge coefficients for rectangular notch weirs. . . . .	285
17. Discharge per inch of length over rectangular notch weirs . . . . .	286
18. Discharge per foot of length over rectangular notch weirs . . . . .	287
19. Principles of mechanics . . . . .	288
20. Discharge per foot of length over suppressed weirs . . . . .	290
INDEX . . . . .	291



# ELEMENTS OF HYDRAULICS

## SECTION I.

### HYDROSTATICS

#### 1. PROPERTIES OF A PERFECT FLUID

**Definition.**—A fluid is defined, in general, as a substance which offers no resistance to change in form provided this deformation is not accompanied by change in volume. The fundamental property of a fluid is the perfect mobility of all its parts.

Most of the applications of the mechanics of fluids relate to water, and this domain of mechanics is therefore usually called *hydraulics* or *hydromechanics*. It is convenient to subdivide the subject into *hydrostatics*, relating to water at rest; *hydrokinetics*, relating to water in motion; and *hydrodynamics*, relating to the inertia forces exerted by fluids in motion, and the energy available from them.

**Distinction between Liquid and Gas.**—A liquid such as water has a certain degree of cohesion, causing it to form in drops, whereas a gaseous fluid tends to expand indefinitely. A gas is therefore only in equilibrium when it is entirely enclosed. In considering elastic fluids such as gas and steam, it is always necessary to take account of the relation between volume and pressure. For a constant pressure the volume also changes greatly with the temperature. For this reason the mechanics of gases is concerned chiefly with heat phenomena, and forms a separate field called thermodynamics, lying outside, and supplementary to, the domain of ordinary mechanics.

**Elasticity of Water.**—Water, like other fluids, is elastic, and under heavy pressure its volume is slightly diminished. However, since a pressure of one atmosphere, or 14.7 lb. per square inch, exerted on all sides only decreases its volume about  $\frac{1}{20,000}$ , and a pressure of 3000 lb. per square inch, only 1 per cent., it is customary in all practical calculations, and sufficiently accurate

for ordinary purposes, to assume that it is incompressible. The volume of an ideal liquid is therefore assumed to remain constant.

**Fluid Pressure Normal to Surface.**—Since a perfect fluid is one which offers no resistance to change in form, it follows that the pressure on any element of surface of the fluid is everywhere normal to the surface. To prove this proposition, consider any small portion of a fluid at rest, say a small cube. Since this cube is assumed to be at rest, the forces acting on it must be in equilibrium. In the case of a fluid, however, the general conditions of equilibrium are necessary but not sufficient, since they take no account of the fact that the fluid offers no resistance to change in form. Suppose, therefore, that the small cube under consideration undergoes a change in form and position without any change in volume. Since the fluid offers no resistance to this deformation, the total work done on the elementary cube in producing the given change must be zero.

In particular, suppose that the cube is separated into two parts by a plane section, and that the deformation consists in sliding one of these parts on the other, or a *shear* as it is called. Then in addition to the forces acting on the outside of each part, it is necessary to consider those acting across the plane section. But the total work done on each part separately must be zero independently of the other part, and also the total work done on the entire cube must be zero. Therefore, by subtraction, the work done by the forces acting across the plane section must be zero. But when any force is displaced it does work equal in amount to the product of this displacement by the component of the force in the direction of the displacement. Therefore if the work done by the force acting across the plane section of the cube is zero, this force can have no component in the plane of the section, and must therefore be normal, *i.e.*, perpendicular, to the section.

**Viscosity.**—This absence of shear is only rigorously true for an ideal fluid. For water there is a certain amount of shear due to internal friction, or viscosity, but it is so small as to be practically negligible. The greater the shear the more viscous the fluid is said to be, and its amount may be taken as a measure of viscosity. It is found by experiment that the internal friction depends on the difference in velocity between adjacent particles, and for a given difference in velocity, on the nature of the fluid. The viscosity of fluids is therefore of great importance in considering their motion, but does not affect their static equilibrium.



For any fluid at rest, the pressure is always normal to any element of surface.

**Density of Water.**—In hydraulic calculations the unit of weight may be taken as the weight of a cubic foot of water at its temperature of greatest density, namely, 39° F. or 4° C. It is found by accurate measurement that a cubic foot of water at 39° F. weighs 62.42 lb. This constant will be denoted in what follows by the Greek letter  $\gamma$ . In all numerical calculations it must be remembered therefore that

$$\gamma = 62.4 \text{ lb. per cubic foot.} \quad (1)$$

The density and volume of water at various temperatures are given in Table 1.

**Specific Weight.**—The weights of all substances, whether liquids or solids, may be expressed in terms of the weight of an equal volume of water. This ratio of the weight of a given volume of any substance to that of an equal volume of water is called the *specific weight* of the substance, and will be denoted in what follows by  $s$ . For instance, a cubic foot of mercury weighs 848.7 lb., and its specific weight is therefore

$$s = \frac{848.7}{62.4} = 13.6 \text{ approximately.}$$

Its exact value at 0° C. is  $s = 13.596$ , as may be found in Table 1.

The weight of 1 cu. ft. of any substance in terms of its specific weight is then given by the relation

$$\text{Weight} = \gamma s = 62.4s \text{ lb. per cubic foot.} \quad (2)$$

## 2. HYDROSTATIC PRESSURE

**Equal Transmission of Pressure.**—The fundamental principle of hydrostatics is that when a fluid at rest has pressure applied to any portion of its surface, this pressure is transmitted equally to all parts of the fluid.

To prove this principle consider any portion of the fluid limited by a bounding surface of any form, and suppose that a small cylindrical portion is forced in at one point and out at another, the rest of the boundary remaining unchanged (Fig. 1). Then if  $\Delta A$  denotes the cross-sectional area of one cylinder and  $\Delta n$  its height, its volume is  $\Delta A \cdot \Delta n$ . Similarly, the volume of the

other cylinder is  $\Delta A' \cdot \Delta n'$ , and, since the fluid is assumed to be incompressible,

$$\Delta A \cdot \Delta n = \Delta A' \cdot \Delta n'$$

Now let  $p$  denote the unit pressure on the end of the first cylinder, *i.e.*, the intensity of pressure, or its amount in pounds per square inch. Then the total pressure normal to the end is  $p\Delta A$ , and the work done by this force in moving the distance  $\Delta n$  is  $p\Delta A \cdot \Delta n$ . Similarly, the work done on the other cylinder is  $p'\Delta A' \cdot \Delta n'$ . Also, if  $\gamma$  denotes the heaviness of the fluid per unit volume, the work done by gravity in moving this weight  $\gamma\Delta A \cdot \Delta n$  through the distance  $h$ , where  $h$  denotes the difference in level between the two elements

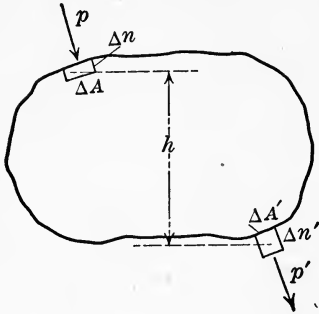

FIG. 1.

considered, is  $\gamma\Delta A \cdot \Delta n \cdot h$ . Therefore, equating the work done on the fluid to that done by it, we have

$$p\Delta A \cdot \Delta n + \gamma\Delta A \cdot \Delta n \cdot h = p' \cdot \Delta A' \cdot \Delta n'$$

Since  $\Delta A \cdot \Delta n = \Delta A' \cdot \Delta n'$ , this reduces to

$$p' = p + \gamma h. \quad (3)$$

If  $h = 0$ , then  $p' = p$ . Therefore the pressure at any point in a perfect fluid is the same in every direction. Also the pressure at the same level is everywhere the same.

Moreover, if the intensity of pressure  $p$  at any point is increased by an amount  $w$ , so that it becomes  $p + w$ , then by Eq. (3) the intensity of pressure at any other point at a difference of level  $h$  becomes

$$p'' = (p + w) + \gamma h.$$

But since  $p' = p + \gamma h$ , we have by subtraction,

$$p'' = p' + w,$$

that is, the intensity of pressure at any other point is increased by the same amount  $w$ . A pressure applied at any point is therefore transmitted equally to all parts of the fluid.

For fluids such as gas and steam the term  $\gamma h$  is negligible, and consequently for such fluids the intensity of pressure may be assumed to be everywhere the same.

**Pressure Proportional to Area.**—To illustrate the application of this principle consider a closed vessel or tank, filled with water, having two cylindrical openings at the same level, closed by movable pistons (Fig. 2). If a load  $P$  is applied to one piston, then in accordance with the result just proved there is an increase of pressure throughout the vessel of amount

$$p = \frac{P}{A}$$

where  $A$  denotes the area of the piston. The force  $P'$  exerted on the second piston of area  $A'$  is therefore

$$P' = pA' = \frac{PA'}{A},$$

whence

$$\frac{P'}{P} = \frac{A'}{A}.$$

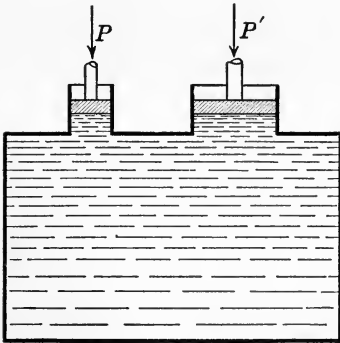

FIG. 2.

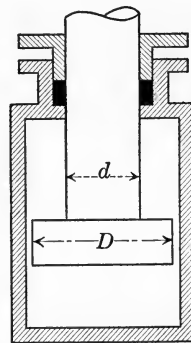

FIG. 3.

The two forces considered are therefore in the same ratio as their respective areas. This relation remains true whatever shape the ends of the pistons may have, the areas  $A$  and  $A'$  in any case being the cross-sectional areas of the openings. For instance, an enlargement of the end of the piston, such as shown in Fig. 3, has no effect on the force transmitted, since the upward and downward pressures on the ring of area  $\frac{\pi(D^2 - d^2)}{4}$  cancel, leaving  $\pi d^2$  as the effective area.

**Hydraulic Press.**—An important practical application of the law of hydrostatic pressure is found in the hydraulic press. In its essential features this consists of two cylinders, one large and one small, each fitted with a piston or plunger, and connected by a pipe through which water can pass from one cylinder to the other (Fig. 4). Let  $p$  denote the intensity of pressure within the fluid,  $D$ ,  $d$  the diameters of the two plungers,  $P$  the load applied

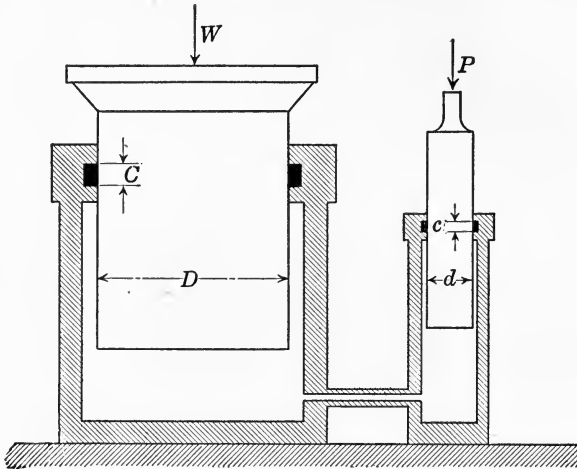

FIG. 4.

to one and  $W$  the load supported by the other, as indicated in the figure. Then

$$W = \frac{\pi D^2}{4} \cdot p, \quad P = \frac{\pi d^2}{4} \cdot p$$

and consequently

$$\frac{W}{P} = \frac{D^2}{d^2}. \quad (4)$$

If the small plunger moves inward a distance  $h$ , the large one will be forced out a distance  $H$  such that each will displace the same volume, or

$$\frac{\pi d^2 h}{4} = \frac{\pi D^2 H}{4},$$

whence

$$h = H \frac{D^2}{d^2}.$$

Neglecting friction, the work done by the force  $P$  in moving the distance  $h$  is then

$$Ph = P \left( H \frac{D^2}{d^2} \right) = H \left( P \frac{D^2}{d^2} \right) = HW,$$

and is therefore equal to the work done in raising  $W$  the distance  $H$ .

**Frictional Resistance of Packing.**—Usually, however, there is considerable frictional resistance to be overcome, since for high pressures, common in hydraulic presses, heavy packing is necessary to prevent leakage. One form of packing extensively used is the U leather packing shown in Fig. 5. In this form of packing the water leaking past the plunger, or ram as it is often called, enters the leather cup pressing one side against the cylinder and the other against the ram, the pressure preventing leakage being proportional to the pressure of the water.

To take into account the frictional resistance in this case, let  $\mu$  denote the coefficient of friction between leather and ram,  $C, c$  the depths of the packing on the large and small rams (Fig. 4), and  $p$  the intensity of water pressure. Then the area of leather in contact with the large ram is  $\pi DC$  and its frictional resistance is therefore  $\pi DCp\mu$ . Similarly, the frictional resistance for the small ram is  $\pi dc p\mu$ . Consequently

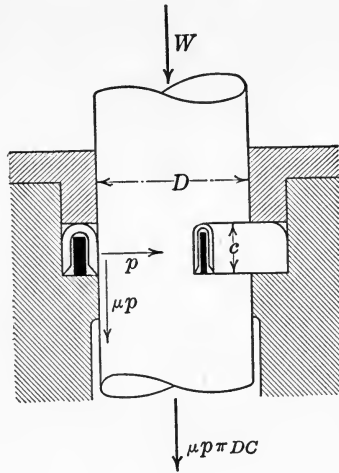

FIG. 5.

$$W = \frac{\pi D^2}{4} p - \mu p \pi DC,$$

and

$$P = \frac{\pi d^2}{4} p + \mu p \pi dc,$$

whence

$$\frac{W}{P} = \frac{D^2}{d^2} \left( \frac{1 - 4\mu \frac{C}{D}}{1 + 4\mu \frac{c}{d}} \right). \tag{5}$$

**Efficiency of Hydraulic Press.**—The efficiency of any apparatus or machine for transforming energy is defined as

$$\text{Efficiency} = \frac{\text{Useful work or effort}}{\text{Total available work or effort}},$$

and is therefore always less than unity. In the present case if there were no frictional resistance the relation between  $W$  and  $P$  would be given by Eq. (4). The efficiency for this type of press is therefore the ratio of the two equations (5) and (4), or

$$\text{Efficiency} = \frac{1 - 4\mu \frac{C}{D}}{1 + 4\mu \frac{c}{d}} \quad (6)$$

### 3. SIMPLE PRESSURE MACHINES

**Hydraulic Intensifier.**—Besides the hydraulic press described in Art. 2 there are a number of simple pressure machines

based on the principle of equal distribution of pressure throughout a liquid. Four types are here illustrated and described, as well as their combination in a hydraulic installation.

When a hydraulic machine such as a punch or riveter is finishing the operation, it is required to exert a much greater force than at the beginning of the stroke. To provide this increase in pressure, an *intensifier* is used (Fig. 6). This consists of several cylinders telescoped one inside another. Thus in Fig. 6, which shows a simple form of intensifier, the largest cylinder  $A$  is fitted with a ram  $B$ . This ram is hollowed out to form another cylinder  $C$ , fitted with a smaller ram  $D$ , which is fixed to the yoke at the top.

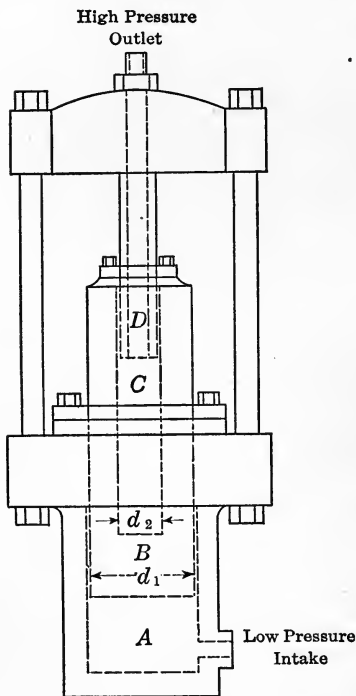

FIG. 6.

the cylinder  $A$  through the intake, thereby forcing the ram  $B$  upward. This has the effect of forcing the ram  $D$  into the cylinder  $C$ , and the water in  $C$  is thereby forced out through  $D$ , which is hollow, at an increased pressure. Let  $p_1$  denote the pressure

of the feed water,  $p_2$  the intensified pressure in  $C$  and  $d_1, d_2$  the diameters of the cylinders  $B$  and  $C$  respectively, as indicated in the figure. Then

$$\frac{\pi d_1^2}{4} p_1 = \frac{\pi d_2^2}{4} p_2$$

whence

$$\frac{p_1}{p_2} = \frac{d_2^2}{d_1^2}.$$

The intensity of pressure in the cylinders is therefore inversely proportional to the areas of the rams.

When a greater intensification of pressure is required a compound intensifier is used, consisting of three or four cylinders and rams, nested in telescopic form, the general arrangement and principle of operation being the same as in the simple intensifier shown in Fig. 6.

**Hydraulic Accumulator.**—A hydraulic accumulator is a pressure regulator or governor, and bears somewhat the same relation to a hydraulic system that the flywheel does to an engine; that is, it stores up the excess pump delivery when the pumps are delivering more than is being used, and delivers it again under pressure when the demand is greater than the supply.

There are two principal types of hydraulic accumulator, in one of which the ram is fixed or stationary, and in the other the cylinder. The latter type is shown in Fig. 7. When the delivery of the pumps is greater or less than required by the machine, water enters or leaves the cylinder of the accumulator through the pipe  $A$ . The ram is thereby raised or lowered, and with it the weights suspended by the yoke from its upper end. The pressure in

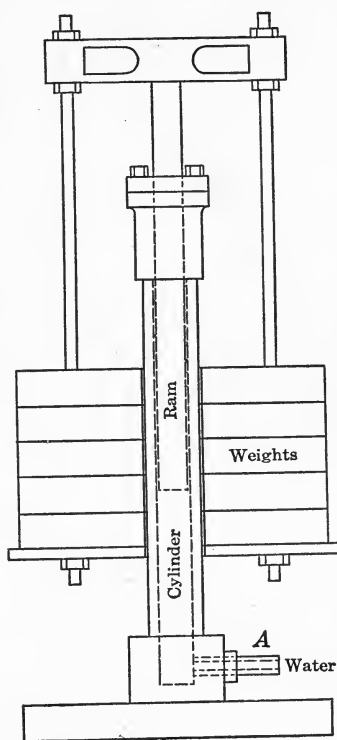

FIG. 7.

the system is thereby maintained constant and free from the pulsations of the pump.

The *capacity* of the accumulator is equal to the volume of the ram displacement, and should be equal to the delivery from the pump in five or six revolutions.

The diameter of the ram should be large enough to prevent a high speed in descent, so as to avoid the inertia forces set up by sudden changes in speed.

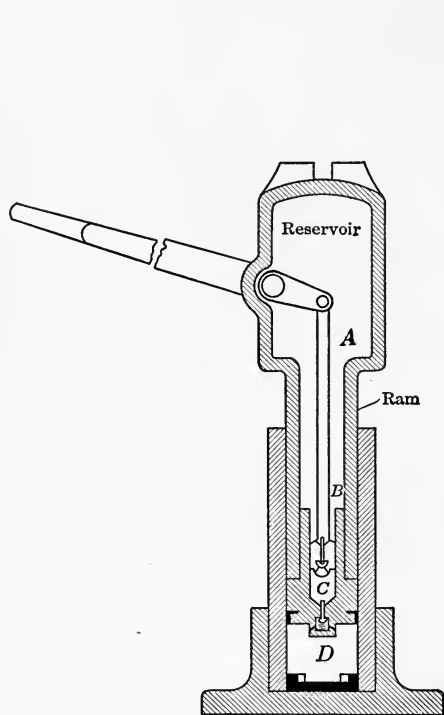

FIG. 8.

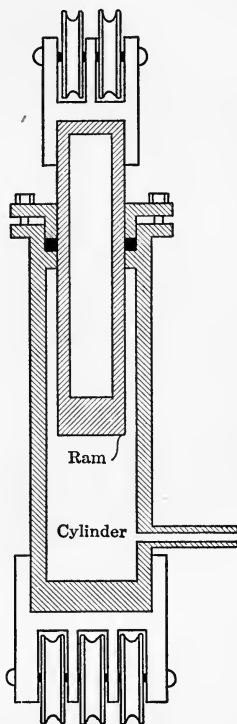

FIG. 9.

**Hydraulic Jack.**—The hydraulic *jack* is a lifting apparatus operated by the pressure of a liquid under the action of a force pump. Thus in Fig. 8 the hand lever operates the pump piston *B*, which forces water from the reservoir *A* in the top of the ram through the valve at *C* into the pressure chamber *D* under the ram. The force exerted is thereby increased in the direct ratio of the areas of the two pistons. Thus if the diameter of the pump piston is 1 in. and the diameter of the lifting piston or ram is 4 in.,



the area of the ram will be sixteen times that of the pump piston. If then a load of, say, 3 tons is applied to the pump piston by means of the lever, the ram will exert an upward lifting force of 48 tons.

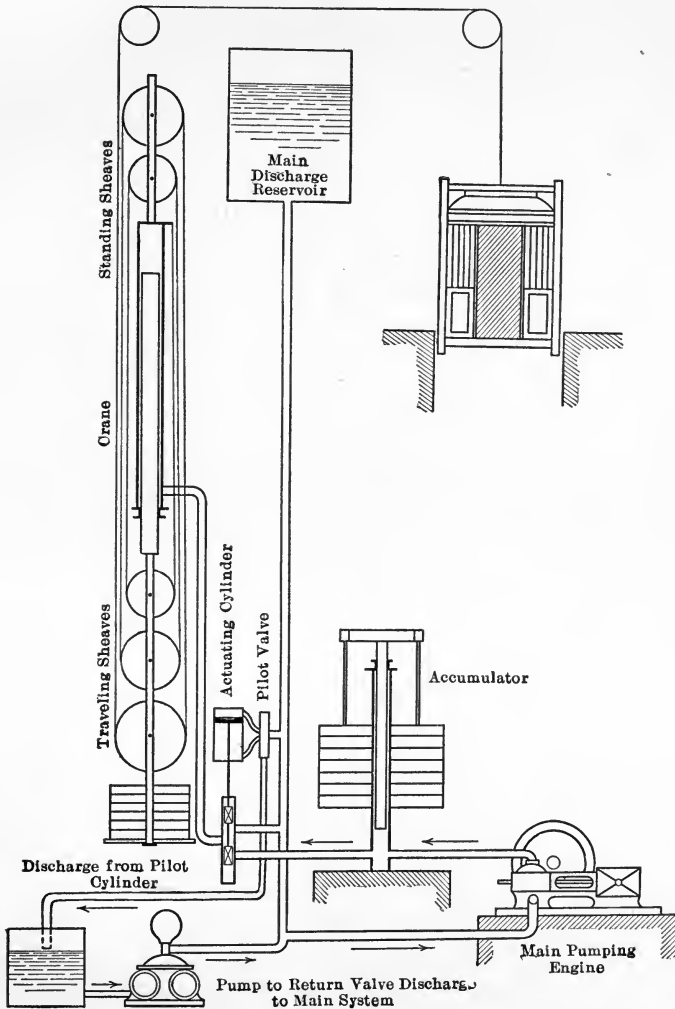

FIG. 10.

**Hydraulic Crane.**—The hydraulic crane, shown in Fig. 9, consists essentially of a ram and cylinder, each carrying a set of

pulleys. A chain or rope is passed continuously over the two sets of pulleys as in the case of an ordinary block and tackle, the free end passing over guide pulleys to the load to be lifted. When water is pumped into the cylinder under pressure, the two pulley blocks are forced apart, thereby lifting the load at the free end of the chain or rope.

**Hydraulic Elevator.**—In hydraulic installations two or more of these simple pressure machines are often combined, as in the hydraulic elevator shown in Fig. 10. In this case the accumulator serves to equalize the pump pressure, making the operation of the system smooth and uniform.

The main valve for starting and stopping is operated, in the type shown, by the discharge pressure, maintained by means of an elevated discharge reservoir. A pilot valve, operated from the elevator cab, admits this low-pressure discharge water to opposite sides of the main valve piston as desired, thereby either admitting high-pressure water from the pump and accumulator, or opening the outlet valve into the discharge. The other details of the installation are indicated on the diagram.

#### 4. PRESSURE ON SUBMERGED SURFACES

**Change of Pressure with Depth.**—For a liquid at rest in an open vessel or tank, the free upper surface is perfectly level. Let the atmospheric pressure on this surface be denoted by  $p$ . Then, from Eq. (3), the pressure  $p'$  at a depth  $h$  below the surface is given by

$$p' = p + \gamma h.$$

Since the atmospheric pressure is practically constant, the free surface of the liquid may be assumed as a surface of zero pressure when considering only the pressure due to the weight of the liquid. In this case  $p = 0$ , and the pressure  $p'$  at any depth  $h$ , due to the weight of the liquid, becomes

$$p' = \gamma h. \quad (7)$$

Hence the pressure at any point in a liquid due to its own weight is directly proportional to the depth of this point below the free upper surface.

Moreover, let  $\Delta A$  denote any element of a submerged surface. Then the pressure on it is

$$p' \Delta A = \gamma h \Delta A.$$

Therefore the pressure on any element of area of a submerged surface is equal to the weight of a column of water of cross section equal to the element considered, and of height equal to the depth of this element below the surface.

**Pressure on Submerged Area.**—Consider the pressure on any finite area  $A$  in the side of a tank a reservoir containing a liquid at rest (Fig. 11). Let  $\Delta A$  denote any element of this area and  $x$  its distance below the surface of the liquid. Then, by what precedes, the pressure on this elementary area is

$$\gamma x \Delta A,$$

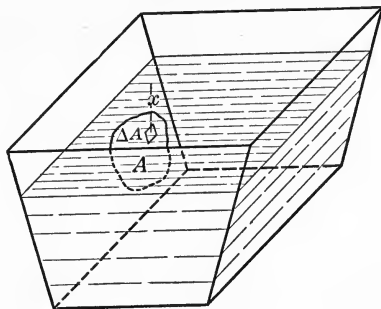

FIG. 11.

and consequently the total pressure  $P$  on the entire area  $A$  is given by the summation

$$P = \Sigma \gamma x \Delta A = \gamma \Sigma x \Delta A.$$

But from the ordinary formula for finding the center of gravity of an area, the distance  $x_0$  of the center of gravity of  $A$  below the surface is given by

$$Ax_0 = \Sigma x \Delta A$$

and consequently

$$P = \gamma Ax_0. \quad (8)$$

*Therefore, the pressure of a liquid on any submerged plane surface is equal to the weight of a column of the liquid of cross section equal to the given area and of height equal to the depth of the center of gravity of this area below the free surface of the liquid.*

**Center of Pressure.**—The point of application of the resultant pressure on any submerged area is called the *center of pressure*, and for any plane area which is not horizontal, lies deeper than the

center of gravity of this area. For instance, consider the water pressure against a masonry dam with plane vertical face (Fig. 12). By Eq. (7) the pressure at any point  $A$  is proportional to the depth of  $A$  below the water surface. If, then, a length  $AB$  is laid off perpendicular to the wall and equal to the depth of  $A$  below the surface, that is,  $AB = AO$ , then  $AB$  will represent to a certain scale the normal pressure at  $A$ . If the same is done at various other points of the wall, their ends,  $B, D$ , etc., will lie in a straight line inclined at  $45^\circ$  to the horizontal. For a portion of

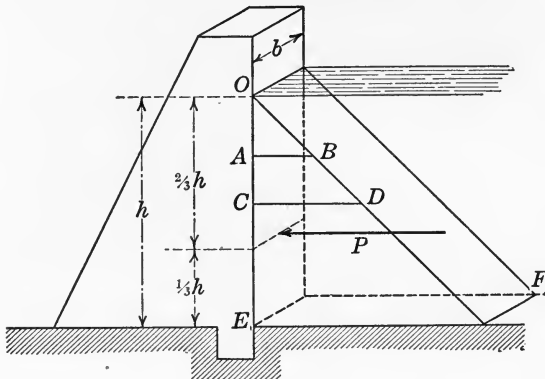

FIG. 12.

the wall of length  $b$ , the pressure acting on it will then be equal to the weight of the water prism  $OEF$ , namely,

$$P = \gamma \frac{bh^2}{2}; \quad (9)$$

and the center of pressure will coincide with the center of gravity of this prism. It therefore lies at a distance of  $\frac{2}{3}h$  below the water surface, which is below the center of gravity of the rectangular area under pressure since the latter is at a distance of  $\frac{h}{2}$  from the surface.

**General Formula for Center of Pressure.**—To obtain a general expression for the location of the center of pressure, consider any plane area inclined at an angle  $\alpha$  to the horizontal (or water surface) and subjected to a hydrostatic pressure on one side. Let  $OO'$  denote the line of intersection of the plane in which the given area lies with the water surface (Fig. 13). Also, let  $\Delta A$  denote any element of the given area,  $h$  the depth of this element below the

surface, and  $x$  its distance from  $OO'$ , as indicated in the figure. Then from Eq. (7), the pressure  $\Delta P$  acting on this element is

$$\Delta P = \gamma h \Delta A,$$

and the moment of this force with respect to the line  $OO'$  is

$$x \Delta P = \gamma h x \Delta A.$$

Now let  $P$  denote the total resultant pressure on the area  $A$  and  $x_c$  the distance of the point of application of this resultant from  $OO'$ , *i.e.*,  $x_c$  represents the  $x$  coordinate of the center of pressure. Then since the sum of the moments of all the elements of pressure

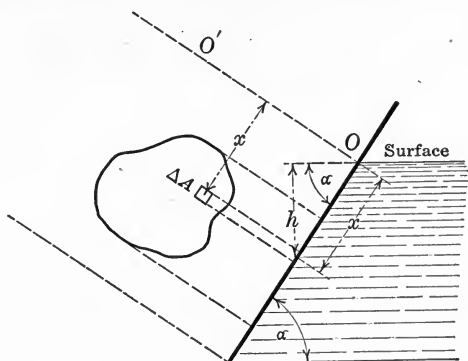

FIG. 13.

with respect to any axis  $OO'$  is equal to the moment of their resultant with respect to this axis, we have

$$\Sigma x \Delta P = P x_c.$$

But  $\Delta P = \gamma h \Delta A$  and  $P = \Sigma \gamma h \Delta A$ . Consequently this becomes

$$\Sigma \gamma h x \Delta A = x_c \Sigma \gamma h \Delta A.$$

Also, since

$$h = x \sin \alpha,$$

this may be written

$$\gamma \sin \alpha \Sigma x^2 \Delta A = \gamma \sin \alpha x_c \Sigma x \Delta A$$

or, cancelling the common factor  $\gamma \sin \alpha$ ,

$$\Sigma x^2 \Delta A = x_c \Sigma x \Delta A.$$

The left member of this expression is by definition the moment of inertia,  $I$ , of the area  $A$  with respect to the line  $OO'$ , that is

$$I = \Sigma x^2 \Delta A,$$

while by the formula for the center of gravity of any area  $A$  we also have

$$\Sigma x \Delta A = x_0 A$$

where  $x_0$  denotes the  $x$  coordinate of the center of gravity of  $A$ . The  $x$  coordinate of the center of pressure is therefore determined by the general formula

$$x_c = \frac{I}{Ax_0}.$$

**Application.**—In applying this formula it is convenient to use the familiar relation

$$I = I_g + Ad^2$$

where

$I$  = moment of inertia of  $A$  with respect to the axis  $OO'$ ;

$I_g$  = moment of inertia of  $A$  with respect to a gravity axis parallel to  $OO'$ ;

$d$  = distance between these two parallel axes.

For example, in the case of the vertical dam under a hydrostatic head  $h$ , considered above, we have for a rectangle of breadth  $b$  and height  $h$ ,

$$I_g = \frac{bh^3}{12}.$$

Consequently the moment of inertia  $I$  with respect to its upper edge is

$$I = \frac{bh^3}{12} + bh \left(\frac{h}{2}\right)^2 = \frac{bh^3}{3},$$

and therefore the depth of the center of pressure below the surface is

$$x_c = \frac{I}{Ax_0} = \frac{\frac{bh^3}{3}}{bh \left(\frac{h}{2}\right)} = \frac{2}{3}h,$$

which, of course, agrees with the result obtained geometrically.

## 5. EQUILIBRIUM OF TWO FLUIDS IN CONTACT

**Head Inversely Proportional to Specific Weight.**—If two open vessels containing the same fluid, say water, are connected by a tube, the fluid will stand at the same level in both vessels (Fig. 14). If the two vessels contain different fluids which are of

different weights per unit of volume, that is to say, of different specific gravities, then since the fluid in the connecting tube must exert the same pressure in either direction, the surface of the lighter fluid will be higher than that of the heavier.

For instance, let  $s_1$  and  $s_2$  denote the specific gravities of the two fluids in the apparatus shown in Fig. 15, and let  $A$  denote the area of their surface of contact. Then for equilibrium

$$\gamma s_1 A h = \gamma s_2 A H$$

whence

$$\frac{h}{H} = \frac{s_2}{s_1} \tag{10}$$

The ratio of the heights of the two fluids above their surface of separation is therefore inversely proportional to the ratio of their specific gravities.

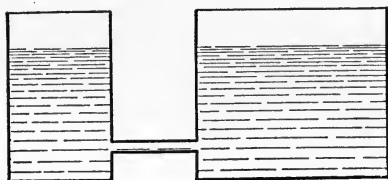

FIG. 14.

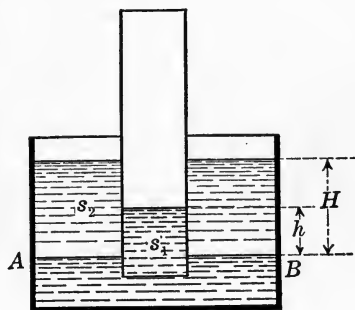

FIG. 15.

**Water Barometer.**—If one of the fluids is air and the other water, we have what is called a *water barometer*. For example, suppose that a long tube closed at one end is filled with water and the open end corked. Then if it is placed cork downward in a vessel of water and the cork removed, the water in the tube will fall until it stands at a certain height  $h$  above the surface of the water in the open vessel, thus leaving a vacuum in the upper end of the tube. The absolute pressure in the top of the tube,  $A$  (Fig. 16), is therefore zero, and at the surface,  $B$ , is equal to the pressure of the atmosphere, or approximately 14.7 pounds per square inch. But from Eq. (3) we have

$$p_B = p_A + \gamma h$$

where in the present case

$p_B = 14.7$  lb. per square inch;  $p_A = 0$ ;  $\gamma = 62.4$  lb. per cubic foot and by substitution of these values we find that

$$h = 34 \text{ ft. approximately.}$$

This is the height, therefore, at which a water column may be maintained by ordinary atmospheric pressure. It is therefore also the theoretical height to which water may be raised by means of an ordinary suction pump. As it is impossible in practice to secure a perfect vacuum, however, the actual working lift for a suction pump does not exceed 20 or 25 ft.

**Mercury Barometer.**—If mercury is used instead of water, since the specific gravity of mercury is  $s = 13.5956$ , we have

$$h = \frac{14.7 \times 144}{13.6 \times 62.4} = 30 \text{ in., approximately,}$$

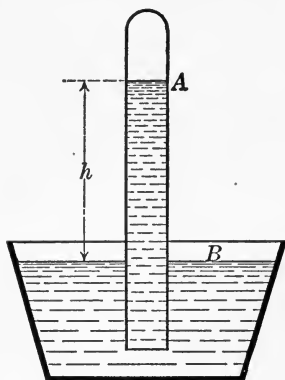

FIG. 16.

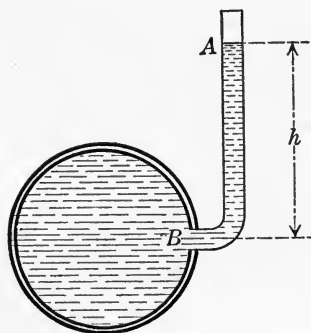

FIG. 17.

which is accordingly the approximate length of an ordinary mercury barometer.

**Piezometer.**—When a vessel contains liquid under pressure, this pressure is conveniently measured by a simple device called a *piezometer*. In its simplest form this consists merely of a tube inserted in the side of the vessel, of sufficient height to prevent overflow and large enough in diameter to avoid capillary action, say over 1/4 in. inside diameter. The height of the free surface of the liquid in the tube above any point  $B$  in the vessel then measures the pressure at  $B$  (Fig. 17). Since the top of the tube is open to the atmosphere, the absolute pressure at  $B$  is that due to a head of  $h + 34$  ft.



**Mercury Pressure Gage.**—In general it is convenient to use a mercury column instead of a water column, and change the form of the apparatus slightly. Thus Fig. 18 shows a simple form of mercury pressure gage, the difference in level,  $h$ , of the two ends

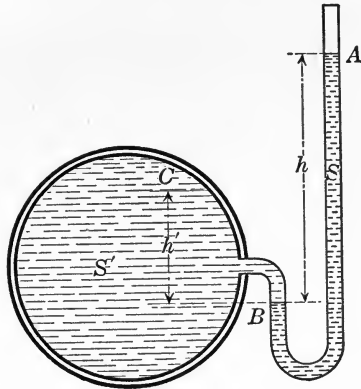

FIG. 18.

of the mercury column measuring the pressure at  $B$ . Let  $s$  denote the specific weight of mercury and  $s'$  the specific weight of the fluid in the vessel. The pressure at any point  $C$  in the vessel is then

$$p_c = \gamma sh - \gamma s'h'. \tag{11}$$

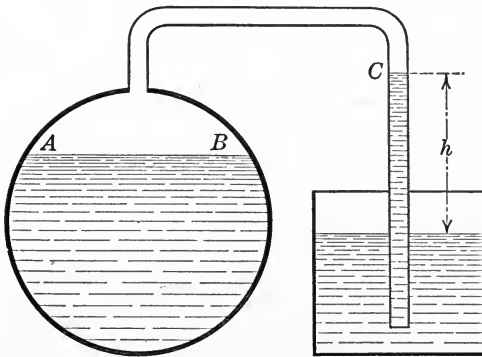

FIG. 19.

For example, if the fluid in the vessel is water, then  $\gamma = 62.4$ ,  $s' = 1$ ,  $s = 13.596$ , and consequently

$$p_c = 62.4(13.596h - h').$$

In case there is a partial vacuum in the vessel, the gage may be of the form shown in Fig. 19. The pressure on the free surface  $AB$  in the reservoir is then the same as at the top of the barometer column,  $C$ , namely,

$$p_c = 14.7 - \gamma sh.$$

## 6. EQUILIBRIUM OF FLOATING BODIES

**Buoyancy.**—When a solid body floats on the water partially submerged, as in the case of a piece of timber or the hull of a ship, each element of the wetted surface experiences a unit normal pressure of amount

$$p = \gamma h$$

where  $h$  denotes the depth of the element in question below the water surface. Since the body is at rest, the total pressure acting

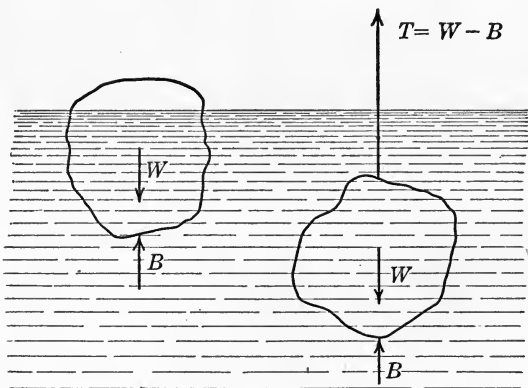

FIG. 20.

on the wetted surface together with the weight of the body, which in this case is the only other external force, must then form a system in equilibrium. Since the weight of the body acts vertically downward, the water must therefore exert an upward pressure of the same amount. This resultant upward pressure of the water is called the buoyant effort, or *buoyancy*, and the point of application of this upward force is called the *center of buoyancy*. For equilibrium, therefore, the buoyancy must be equal to the weight of the body and act vertically upward along the same line, since otherwise these two forces would form a couple tending to tip or rotate the body (Fig. 20).

**Floating Equilibrium.**—To calculate the buoyancy, suppose that the solid body is removed and the space it occupied below the water line refilled with water. Then since the lateral pressure of the water in every direction must be exactly the same as before, the buoyancy must be equal to the weight of this volume of water. The buoyancy is therefore equal to the weight of the volume of water displaced by the floating body, and the center of buoyancy coincides with the center of gravity of the displacement. For equilibrium, therefore, a solid body must sink until the weight of the water it displaces is equal to the weight of the body, and the centers of gravity of the body and its displacement must lie in the same vertical.

These conditions also apply to the case when a body is entirely submerged. As the density of water increases with the depth, if a solid is slightly heavier than the water it displaces, it will sink until it reaches a depth at which the density is such that the weight of the water it displaces is exactly equal to its own weight.

**Theorem of Archimedes.**—If a solid is heavier than the weight of water it displaces, equilibrium may be maintained by suspending the body in water by a cord (Fig. 20), in which case the tension,  $T$ , in the cord is equal to the difference between the weight of the body and its buoyancy, that is, the weight of the water it displaces. A solid immersed in a liquid therefore loses in weight an amount equal to the weight of the liquid displaced. This is known as the *Theorem of Archimedes*, and was discovered by him about the year 250 B. C.

**Physical Definition of Specific Weight.**—Consider a solid completely immersed in a liquid, and let  $V$  denote the volume of the solid, and  $\gamma$  the weight of a cubic unit of the liquid, say 1 cu. ft. Then the buoyancy,  $B$ , of the body is

$$B = \gamma V.$$

Also, if  $\gamma_1$  denotes the weight of a cubic unit of the solid, regarded as uniform and homogeneous, its weight is

$$W = \gamma_1 V.$$

The ratio

$$\frac{W}{B} = \frac{\gamma_1}{\gamma} = s \quad (12)$$

is called the *specific weight* of the solid with respect to the liquid in which it is immersed (compare Art. 1). In general, the liquid to which the specific weight refers is assumed to be water at a

temperature of 39° F. The specific weight of any substance is then that abstract number which expresses how many times heavier it is than an equal volume of water at 39° F. The specific weight of water is therefore unity; for lighter substances such as wood or oil it is less than unity; and for heavier substances like lead and mercury it is greater than unity.

**Determination of Specific Weight by Experiment.**—The specific weight of a body may be determined by first weighing it in air and again when immersed in water. The actual weight of the body in air is then

$$W = \gamma_1 V = \gamma sV$$

where  $s$  denotes its specific weight, and its apparent weight  $T$  when immersed (Fig. 20) is

$$T = W - B = \gamma sV - \gamma V = \gamma V(s - 1),$$

that is,

$$T = \gamma V(s - 1). \quad (13)$$

Therefore, by division,

$$\frac{W}{T} = \frac{s}{s - 1}$$

whence

$$s = \frac{W}{W - T}. \quad (14)$$

The specific weight of a body is therefore equal to its weight in air divided by its loss in weight when immersed in water.

**Application to Alloy.**—If a body is an alloy or mixture of two different substances whose specific weights are known, the volume of each substance may be determined by weighing the body in air and in water. Thus let  $V_1$  denote the volume, and  $s_1$  the specific weight, of one substance, and  $V_2$ ,  $s_2$  of the other. Then the weight of the body in air is

$$W = \gamma V_1 s_1 + \gamma V_2 s_2$$

and its apparent weight  $T$  when immersed is, from equation (13),

$$T = \gamma V_1 (s_1 - 1) + \gamma V_2 (s_2 - 1).$$

Solving these two equations simultaneously for  $V_1$  and  $V_2$ , the result is

$$V_1 = \frac{T - \left(1 - \frac{1}{s_2}\right)W}{\left(\frac{s_1}{s_2} - 1\right)\gamma},$$

$$V_2 = \frac{T - \left(1 - \frac{1}{s_1}\right)W}{\left(\frac{s_2}{s_1} - 1\right)\gamma}$$

This method of determining relative volumes was invented by Archimedes in order to solve a practical problem. Hiero, King of Syracuse, had furnished a quantity of gold to a goldsmith to be made into a crown. When the work was completed the crown was found to be of full weight, but it was suspected that the goldsmith had kept out a considerable amount of gold and substituted an equal weight of silver. To test the truth of this suspicion Archimedes first balanced the crown in air against an equal weight of gold, and then immersed both in water, when the gold was found to outweigh the crown, proving the goldsmith to be dishonest.

**Zero Buoyancy.**—When a body lies flat against the bottom of a vessel filled with water, fitting the bottom so closely that no water can get under it, its buoyancy is zero. In this case if  $W$  denotes the weight of the body,  $A$  the area of its horizontal cross section, and  $h$  the depth of water on it, the force  $T$  required to lift it is (Fig. 21)

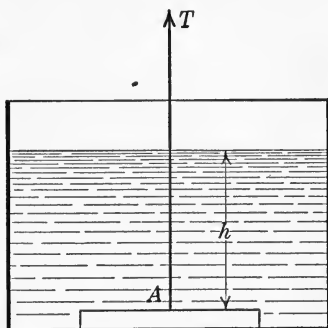

FIG. 21.

$$T = W + \gamma Ah.$$

That is to say, the force  $T$  is the same as would be necessary to lift the body itself and the entire column of water vertically over it.

This same principle underlies the action of a leather sucker or vacuum tipped arrow, the fluid in that case being air.

## 7. METACENTER

**Stability of Floating Body.**—When a floating body is shoved to one side it remains in this position and is therefore in neutral equilibrium as regards lateral translation. In determining the stability of a floating body it is therefore only necessary to consider its equilibrium as regards rotation.

After a floating body has been tipped or rotated a small amount from its position of equilibrium, the buoyancy, in general, no longer passes through the center of gravity of the body. Consequently the weight and buoyancy together form a couple tending to produce rotation or tip the body. If this couple tends to right the body the equilibrium is stable, whereas if it tends to tip it over it is unstable. This evidently depends on the form of the

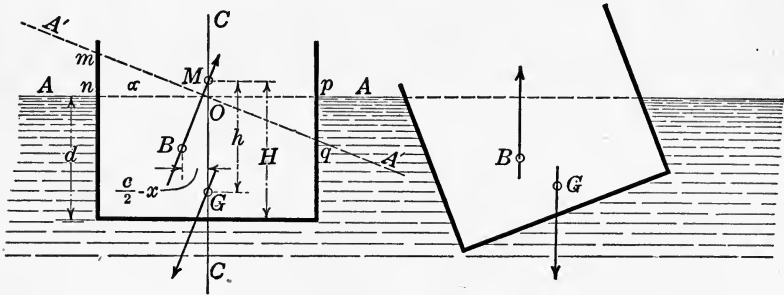

FIG. 22.

wetted surface, and also on the form of the part immersed by the rotation.

**Metacenter.**—For example, consider a floating box of rectangular cross section, immersed to a depth  $d$  below the surface  $AA$  (Fig. 22), and suppose it is tipped by an external couple until the water line becomes  $A'A'$ . In this new position the displacement is trapezoidal, and the center of buoyancy  $B$  is the center of gravity of this trapezoid. But since the buoyancy is of the same amount as before the box was tipped and the triangle of immersion  $mno$  is equal to the triangle of emersion  $opq$ , the lines  $AA$  and  $A'A'$  intersect on the vertical axis

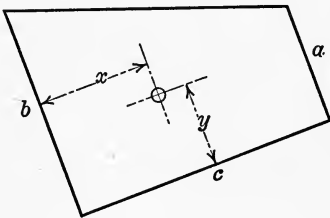

FIG. 23.

$CC$ . The intersection  $M$  of the line of action of the buoyancy with the vertical axis  $CC$  is called the *metacenter*. Evidently the location of the metacenter depends on the angle of tip and is different for each position. It is also apparent that the equilibrium is stable if the metacenter  $M$  lies above the center of gravity  $G$  of the body, and unstable if  $M$  lies below  $G$ . It is also shown in what follows that the metacenter moves higher as

the angle of tip,  $\alpha$ , increases. Its lowest position is called the *true metacenter*.

**Coordinates of Metacenter.**—For the special case of the rectangular cross section shown in Fig. 22, let  $x$ ,  $y$  denote the coordinates of the center of gravity of the trapezoid, and  $a$ ,  $b$ ,  $c$  the lengths of three sides (Fig. 23). Then from geometry,

$$x = \frac{c(2a + b)}{3(a + b)}; \quad y = \frac{a^2 + ab + b^2}{3(a + b)}.$$

From Fig. 21 the sides  $a$  and  $b$  of the trapezoid expressed in terms of  $d$  and  $\alpha$  are

$$a = d - \frac{c}{2} \tan \alpha; \quad b = d + \frac{c}{2} \tan \alpha.$$

Inserting these values of  $a$  and  $b$  in the expressions for  $x$  and  $y$ , the result is

$$x = \frac{c\left(3d - \frac{c}{2} \tan \alpha\right)}{6d}; \quad y = \frac{3d^2 + \frac{c^2}{4} \tan^2 \alpha}{6d}.$$

Also, from Fig. 22, the total height  $H$  of the metacenter above the bottom of the vessel or box is

$$H = y + \left(\frac{c}{2} - x\right) \cot \alpha.$$

Hence by inserting the above values for  $x$  and  $y$  in this expression for  $H$  and reducing, we obtain the relation

$$H = \frac{d}{2} + \frac{c^2}{24d} (\tan^2 \alpha + 2). \quad (15)$$

The height  $H$  therefore increases with  $\alpha$ ; that is, the greater the angle of tip, the higher the metacenter  $M$ . Moreover, by substituting  $\alpha = 0$  in Eq. (15) the position of the true metacenter, or limiting position of  $M$ , is found to be at a height  $H'$  above the bottom given by

$$H' = \frac{d}{2} + \frac{c^2}{12d}. \quad (16)$$

To prevent a ship from capsizing, it is necessary to so design and load it that the height of its center of gravity above the bottom shall be less than  $H'$ .

**Metacentric Height.**—To consider the general case of equilibrium of a floating body, take a vertical cross section through

the center of gravity  $G$  of the body (Fig. 24), and suppose that by the application of an external couple it is slightly tipped or rotated about an axis  $OY$ , drawn through  $O$  perpendicular to the plane of the paper. Then the volume displaced remains unchanged, but the center of buoyancy  $B$  is moved to some other point  $B'$ . To find the *metacentric height*  $h_y$ , or distance from the center of gravity  $G$  of the body to the metacenter  $M$ , let

$V$  = volume of liquid displaced,

$A$  = cross-sectional area of body in plane of flotation,

$b$  = distance from center of gravity  $G$  to center of buoyancy  $B$ ,

$k_y$  = radius of gyration of area of flotation  $A$  about the axis  $OY$ .

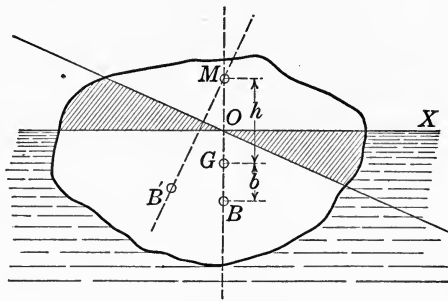

FIG. 24.

Then it can be shown that<sup>1</sup>

$$h_y = \frac{Ak_y^2}{V} - b. \quad (17)$$

Similarly, for rotation about the axis  $OX$ , the metacentric height  $h_x$  is given by

$$h_x = \frac{Ak_x^2}{V} - b, \quad (18)$$

where  $k_x$  denotes the radius of gyration of the area of flotation  $A$  about the axis  $OX$ .

Evidently the metacentric height is greater for a displacement about the shorter principal axis of the section  $A$ . For instance, it is easier to make a ship roll than to cause it to tip endwise or pitch.

The locus of the centers of buoyancy for all possible displacements

<sup>1</sup> Webster, *Dynamics of Particles*, p. 474. (Teubner).



ments is called the *surface of buoyancy*, and the two metacenters given by Eqs. (17) and (18) are the centers of curvature of its principal sections.

**Period of Oscillation.**—When a floating body is tipped and then released, it will oscillate, or roll, with a simple harmonic motion. To find the period of the oscillation, the general expression for the period of oscillation of a solid body rotating about a fixed axis may be applied, namely<sup>1</sup>

$$P = 2\pi \sqrt{\frac{I}{Wh}}, \quad (19)$$

where  $P$  = period or time of a complete oscillation,

$W$  = weight of the body,

$I$  = moment of inertia of the body with respect to the axis of rotation,

$h$  = distance from the center of gravity of the body to the axis of rotation.

Since  $I = MK^2$ , where  $M$  denotes the mass of the body and  $K$  its radius of gyration, and also  $W = Mg$ , Eq. (19) for the period may be written

$$P = 2\pi \sqrt{\frac{MK^2}{Mgh}} = \frac{2\pi K}{\sqrt{gh}}. \quad (20)$$

**Rolling and Pitching.**—In the present case, consider rotation about the two principal axes  $OX$  and  $OY$  of the section  $A$  in the plane of floatation, and let  $K_x$ ,  $K_y$  denote the radii of gyration of the solid with respect to these axes, and  $P_x$ ,  $P_y$  the corresponding periods, or times of performing a complete oscillation about these axes. Then from Eq. (20),

$$P_x = \frac{2\pi K_x}{\sqrt{gh_x}}; \quad P_y = \frac{2\pi K_y}{\sqrt{gh_y}}.$$

Substituting in these expressions the values of  $h_x$  and  $h_y$  given by Eqs. (17) and (18), they become

$$P_x = \frac{2\pi K_x}{k_x \sqrt{g \left( \frac{A}{V} - \frac{b}{k_x^2} \right)}}; \quad P_y = \frac{2\pi K_y}{k_y \sqrt{g \left( \frac{A}{V} - \frac{b}{k_y^2} \right)}}. \quad (21)$$

For a body shaped like a ship,  $K$  and  $k$  increase together, and consequently the larger value of  $k$  corresponds to the smaller period  $P$ . A ship therefore pitches more rapidly than it rolls.

<sup>1</sup> Slocum, *Theory and Practice of Mechanics*, p. 302. (Holt & Co.)

For further applications of the metacenter the student is referred to works on naval architecture.

### APPLICATIONS

1. The ram of a hydraulic press is 10 in. in diameter and the plunger is 2 in. in diameter. If the plunger is operated by a handle having a leverage of 8 to 1, find the pressure exerted by the ram, neglecting friction, when a force of 150 lb. is applied to the handle.

2. In a hydraulic press the diameter of the ram is 15 in. and of the plunger is  $\frac{3}{4}$  in. The coefficient of friction may be assumed as 0.12 and the width of the packing on ram and plunger is 0.2 of their respective diameters. What pressure will be exerted by the ram when a force of 200 lb. is applied to the plunger?

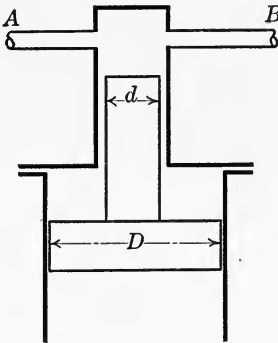

FIG. 25.

3. Water in a pipe  $AB$  is to be kept at a constant pressure of 1200 lb. per square inch by forcing in a plunger of diameter  $d$  (Fig. 25). This is operated by a piston of diameter  $D$ , whose lower surface is subjected to the pressure of a column of

water 75 ft. high. Find the ratio of the two diameters  $d$  and  $D$ .

4. In a hydraulic pivot bearing, a vertical shaft carrying a total load  $W$  is supported by hydraulic pressure (Fig. 26). The pivot is of diameter  $D$ , and is surrounded by a  $U$  leather packing of width  $c$ . Show that the frictional moment, or resistance to rotation, is given by the relation

$$M = 2 \mu c W$$

where  $\mu$  denotes the coefficient of friction.

5. For an ordinary flat pivot bearing of the same diameter  $D$  and for the same coefficient of friction  $\mu$  as in the preceding problem, the frictional moment is given by the relation<sup>1</sup>

$$M = \frac{1}{3} \mu W D.$$

<sup>1</sup> Slocum, Theory and Practice of Mechanics (Holt) p. 194.

Show that the hydraulic pivot bearing is the more efficient of the two provided that

$$c < \frac{D}{6}.$$

Calculate their relative efficiency when  $c = 0.2D$ .

6. An instrument for measuring the depth of the sea consists of a strong steel flask, divided into two compartments which are connected by a valve. The upper compartment is filled with 920 grams of distilled water and the lower compartment with mercury (Fig. 27). When lowered to the bottom, the outside pres-

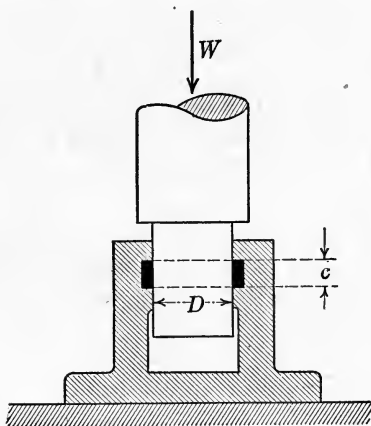

FIG. 26.

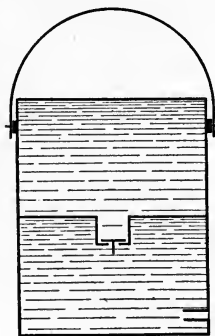

FIG. 27.

sure forces the sea water through a small opening in the side of the flask and thereby forces the mercury through the valve into the upper compartment. Assuming that the depth of the sea in certain parts of the Pacific ocean is 9429 meters, and that the ratio of the densities of distilled and salt water is 35:36, find how many grams of mercury enter the upper compartment.<sup>1</sup> The modulus of compressibility of water is 0.000047, that is, an increase in pressure of one atmosphere produces this decrease in volume.

7. A hydraulic jack has a 3-in. ram and a 3/4-in. plunger. If the leverage of the handle is 10 to 1, find what force must be applied to the handle to lift a weight of 5 tons, assuming the efficiency of the jack to be 75 per cent.

<sup>1</sup> Wittenbauer, Aufgaben aus der Technischen Mechanik, Bd. III.

8. A hydraulic intensifier is required to raise the pressure from 600 lb. per square inch to 2500 lb. per square inch with a stroke of 3 ft. and a capacity of 4 gal. Find the required diameters of the rams.

9. In a hydraulic intensifier like that shown in Fig. 6, the diameters are 2 in., 5 in. and 8 in., respectively. If water is supplied to the large cylinder at a pressure of 500 lb. per square inch, find the pressure at the high pressure outlet.

10. How would the results of the preceding problem be modified if the frictional resistance of the glands, or packing, is taken into account, assuming that the frictional resistance of one stuffing box is  $0.05 pd$ , where  $p$  denotes the water pressure in pounds per square inch, and  $d$  is the diameter of the ram in inches?

11. A hydraulic crane has a ram 10 in. in diameter and a velocity ratio of 1:12, that is, the speed of the lift is twelve times the speed of the ram. Assuming the efficiency of the crane to be 50 per cent., find what load it will lift with a water pressure of 1500 lb. per square inch.

12. A hydraulic crane has a velocity ratio of 1:9 and is required to lift a load of 4 tons. Find the required size of the ram for a pressure in the mains of 750 lb. per square inch, a loss of head due to friction of 75 lb. per square inch, and a mechanical efficiency of 70 per cent.

13. How many foot pounds of work can be stored up in a hydraulic accumulator having a ram 10 in. in diameter and a lift of 12 ft., with a water pressure of 800 lb. per square inch?

14. Find the energy stored in an accumulator which has a ram 10 in. in diameter, loaded to a pressure of 1000 lb. per square inch, and having a stroke of 25 ft. If the full stroke is made in 1 minute find the horsepower available during this time.

15. The stroke of a hydraulic accumulator is fifteen times the diameter of the ram and the water pressure is 1200 lb. per square inch. Find the diameter of the ram for a capacity of 125 horsepower minutes.

16. The ram of a hydraulic accumulator is 20 in. in diameter, the stroke 25 ft., and the water pressure 1050 pounds per square inch. If the work during one full downward stroke is utilized to operate a hydraulic crane which has an efficiency of 50 per cent. and a lift of 35 ft., find the load raised.

17. An accumulator is balanced by means of a chain of length  $l$  passing over two pulleys  $A$  and  $B$  (Fig. 28) and carrying a count-

erweight  $W$  equal to the total weight of the chain. Find the distance apart of the pulleys and the required weight of chain per unit of length in order that this arrangement may balance the difference in pressure during motion.

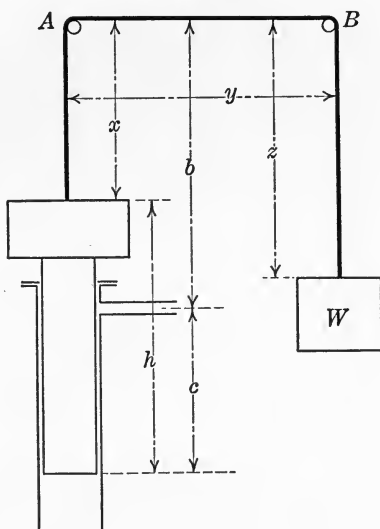

FIG. 28.

*Hint.*—Let  $A$  denote the area of the ram and  $w$  the weight of the chain per unit of length. Then for the dimensions shown in the figure, we have the relations

$$\begin{aligned} wx - wz &= \gamma Ac, \\ x + y + z &= l, \\ x + h &= b + c, \end{aligned}$$

whence

$$w = \frac{\gamma Ac}{2c + 2b - 2h - l + y}.$$

18. A hydraulic accumulator has a ram 15 in. in diameter and carries a load of 60 tons. Assuming the total frictional resistance to be 3 tons, find the required water pressure when the load is being raised and when it is being lowered.

19. Show that the depth of the center of pressure below the surface for a vertical rectangle of breadth  $b$  and depth  $d$ , with upper edge immersed to a depth  $h_1$  and lower edge to a depth  $h_2$  (Fig. 29) is given by the equation

$$x_c = \frac{2}{3} \left( \frac{h_2^3 - h_1^3}{h_2^2 - h_1^2} \right).$$

20. Show that the center of pressure for a vertical plane triangle with base horizontal and vertex at a distance  $h_1$  below the surface (Fig. 30) is given by the equation

$$x_c = \frac{1}{2} \left( \frac{3h_2^2 + 2h_1h_2 + h_1^2}{2h_2 + h_1} \right).$$

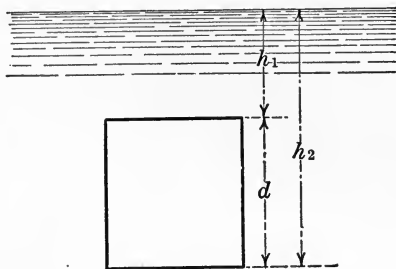

FIG. 29.

21. From the results of the preceding problem show that if the vertex of the triangle lies in the surface, the depth of the center of pressure is

$$x_c = \frac{3}{4} d,$$

and if the base of the triangle lies in the surface

$$x_c = \frac{1}{2} d.$$

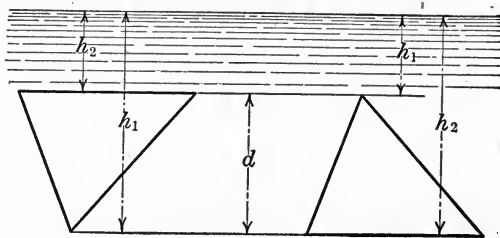

FIG. 30.

22. Show that the depth of the center of pressure below the surface for a vertical circular area of radius  $r$ , immersed so that its center lies at a depth  $h$  below the surface is given by

$$x_c = h + \frac{r^2}{4h}.$$

23. A circular opening, 2 ft. in diameter in the vertical side of a tank is closed by a circular cover held on by two bolts, one 14 in. above the center of the cover and the other 14 in. below its center. When water stands in the tank at a level of 20 ft. above the center of the opening, find the stress in each bolt.

24. A pipe of 4 ft. inside diameter flows just full, and is closed by a valve in the form of a flat circular plate balanced on a horizontal axis. At what distance from the center should the axis be placed in order that the valve may balance about it?

25. An automatic movable flood dam, or flashboard, is made of timber and pivoted to a back stay at a certain point  $C$ , as shown in Fig. 31.

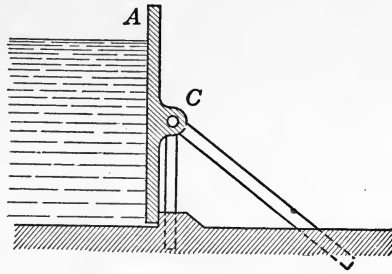

FIG. 31.

The point  $C$  is so located that the dam is stable provided the water does not rise above a certain point  $A$ , but when it rises above this point the dam automatically tips over. Determine where the point  $C$  should be located.

26. An opening in a reservoir wall is closed by a plate  $2-1/2$  ft. square, hinged at the upper edge, and inclined at  $60^\circ$  to the horizontal. The plate weighs 250 lb., and is raised by a vertical chain attached to the middle point of its lower edge. If the center of the plate is 15 ft. below the surface, find the pull on the chain required to open it.

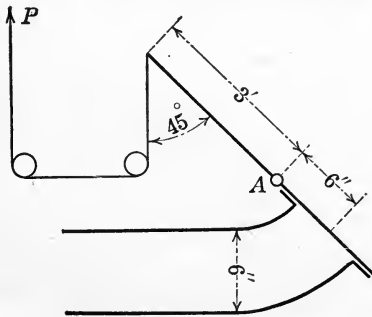

FIG. 32.

27. A rectangular cast-iron sluice gate in the bottom of a dam is 3 ft. high, 4 ft. wide and 3 in. thick. The head

of water on the center of the gate is 35 ft. Assuming the coefficient of friction of the gate on the slides to be  $1/4$ , and that there is no water on the lower side of the gate, find the force required to lift it. Weight of cast iron is 450 lb. per cubic foot.

28. Flow from a reservoir into a pipe is shut off by a flap valve, as shown in Fig. 32. The pivot  $A$  is so placed that the weight of

the valve and arm balance about this point. Calculate the pull  $P$  in the chain required to open the valve for the dimensions given in the figure.

29. The waste gate of a power canal is 8 ft. high and 5 ft. wide, and when closed there is a head of 10 ft. of water on its center. If the gate weighs 1000 lb. and the coefficient of friction between gate and seat is 0.4, find the force required to raise it.

30. A lock gate is 30 ft. wide and the depth of water on the two sides is 28 ft. and 14 ft. respectively. Find the total pressure on the gate and its point of application.

31. A lock is 20 ft. wide and is closed by two gates, each 10 ft. wide. If the depth of water on the two sides is 16 ft. and 4 ft. respectively, find the resultant pressure on each gate and its point of application.

32. A dry dock is 60 ft. wide at water level and 52 ft. wide at floor, which is 40 ft. below water level. The side walls have a straight batter. Find the total pressure on the gates and its point of application when the gates are closed and the dock empty.

33. A concrete dam is 6 ft. thick at the bottom, 2 ft. thick at top and 20 ft. high. The inside face is vertical and the outside face has a straight batter. How high may the water rise without causing the resultant pressure on the base to pass more than 6 in. outside the center of the base?

*Note.*—A dam may fail either by overturning or by sliding. In general, however, if a well-laid masonry dam is stable against overturning it will not fail by sliding on a horizontal joint. To prevent sliding on the base, an anchorage should be provided by cutting steps or trenches in the foundation if it is of rock, or in the case of clay or similar material by making the dam so massive that the angle which the resultant pressure on the base makes with the vertical is less than the angle of friction.

In designing dams it is customary to proportion the section so that the resultant pressure on any horizontal joint shall fall within the middle third of the joint. If this condition is satisfied there will be no danger of tensile stresses developing in the face of the dam.<sup>1</sup>

If water is allowed to seep under a dam, it will exert a lifting effort equal to the weight of a column of water of height equal to static head at this point. To secure stability it is therefore

<sup>1</sup> Slocum and Hancock, *Strength of Materials* (Ginn), Revised Edition, p. 220.



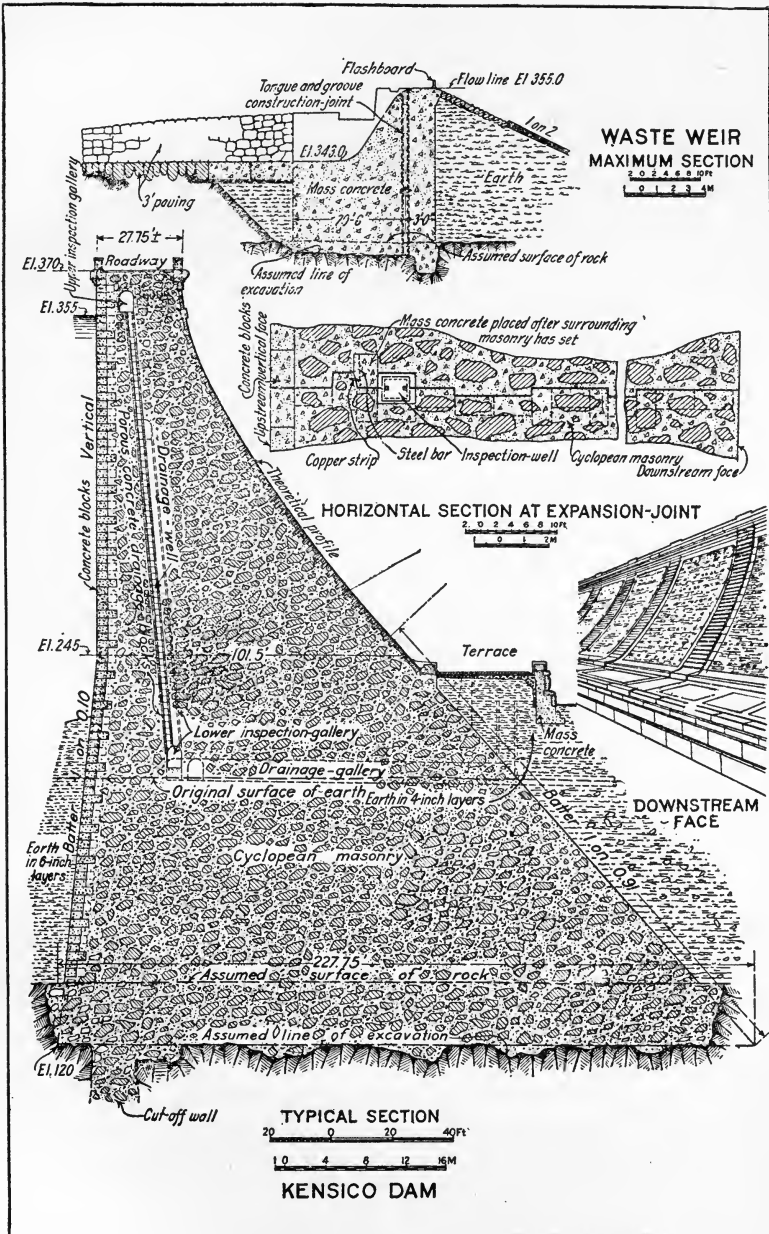

FIG. 33.—Catskill Aqueduct System.

essential to prevent seepage by means of a cut-off wall, as indicated in Figs. 33 and 34.

In investigating the stability of a dam, however, the best practice provides for accidental seepage by making allowance for an upward pressure on the base due to a hydrostatic head of two-thirds the actual depth of water back of the dam.

34. Figure 33 shows a typical section of the Kensico Dam, forming part of the Catskill Water System of the City of New York. The Kensico Reservoir covers 2218 acres, with a shore line 40

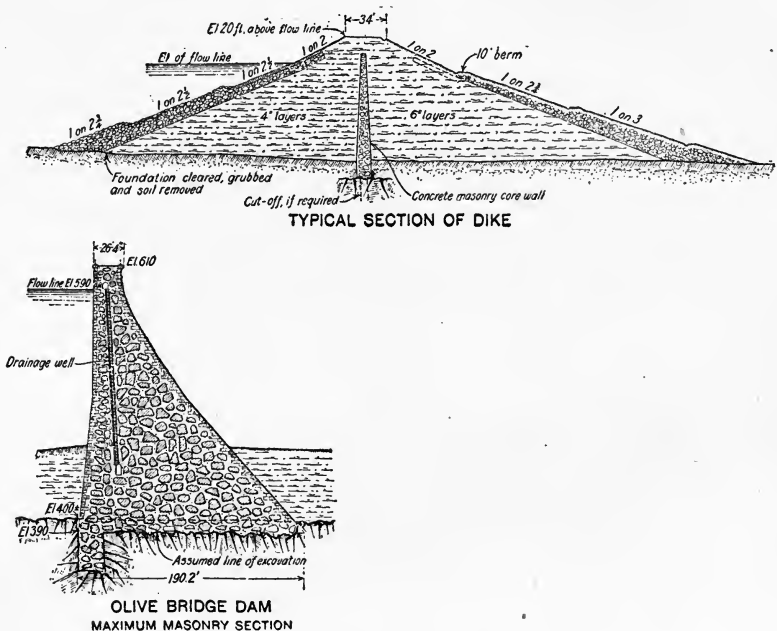

FIG. 34.—Catskill Aqueduct System.

miles in length, and has a storage capacity of 38,000,000,000 gal. The dimensions of the main dam are length 1843 ft.; height 300 ft.; thickness at base 230 ft.; thickness at top 28 ft.

Investigate the stability of this dam in accordance with the conditions stated in the note to Problem 33.

35. Figure 34 shows a section of the Olive Bridge Dam and typical dyke section of the Ashokan Reservoir, which forms part of the Catskill Water System of the City of New York. This reservoir covers 8180 acres, with a shore line 40 miles in length and a storage capacity of 132,000,000,000 gal. The principal dimensions

of the main dam are, length 4650 ft.; height 220 ft.; thickness at base 190 ft.; thickness at top 23 ft.

Investigate the stability of this dam as in the preceding problem.

36. In the \$25,000,000 hydraulic power development on the Mississippi river at Keokuk, Iowa, the dam proper is 4650 ft. long, with a spillway length of 4278 ft. The power plant is designed for an ultimate development of 300,000 h.p., and consists of vertical shaft turbines and generators in units of 10,000 h.p. each. Transmission lines convey the current at 110,000 volts to St. Louis, 137 miles distant, and to other points.<sup>1</sup>

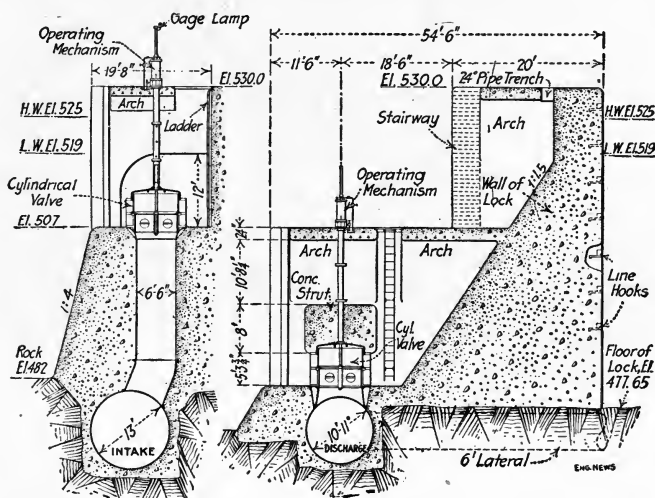

FIG. 35.—Section of side walls of lock at Keokuk, Iowa, showing valves for intake and discharge conduits.

A notable feature of the plant is the ship lock which is of unusual size for river navigation, the lock chamber being 400 ft. long by 110 ft. wide with a single lift of from 30 to 40 ft., the total water content of the lock when full being about 2,200,000 cu. ft. The locks at Panama are the same width but the maximum lift on the Isthmus is 32 ft., the average lift being about 28 ft. Find the maximum pressure on the lock gates at Keokuk and its point of application. (See frontispiece.)

37. The side walls of the Keokuk lock are monolithic masses of concrete, with a base width of 33 ft., a top width of 8 ft., and

<sup>1</sup> Eng. News, Sept. 28, 1911.

an outside batter of 1:1.5, as shown in Fig. 35. If the water stands 48 ft. above the floor of the lock on the inside and 8 ft. on the outside, find the point where the resultant pressure on the side walls intersects the base, neglecting the weight of the roadway on top and the arches which support it.

38. The lower lock gates at Keokuk are of the mitering type, as shown in Figs. 36 and 37, and are very similar to those in the Panama canal locks. The gates are 49 ft. high and each leaf consists of 13 horizontal ribs curved to a radius of 66 ft. 4-3/4 in. on the center line, framed together at the ends by the quoin and

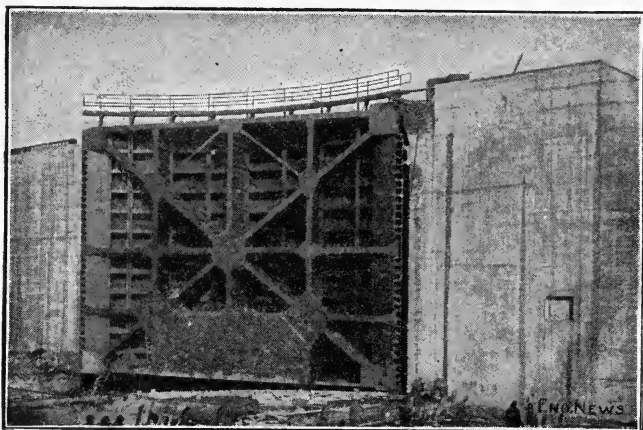

FIG. 36.—Steel miter gates for lower end of lock, showing buoyancy chamber.

miter posts, and also having seven lines of intermediate framing. The chord length over the posts is 66 ft. 4-3/4 in. and the rise of the curve is 10 ft. 8-1/2 in.<sup>1</sup>

Each leaf contains a buoyancy chamber to relieve the weight on the top hinge. This consists of a tank of about 3840 cu. ft. capacity, placed between the curve of the face and the chord line of the bracing. The total weight of each gate in air is about 240 tons. Find how much the buoyancy chamber relieves the weight on the top hinge.

39. The upper gates of the Keokuk lock are of a floating type never before used, and consist essentially of floating tanks moving in vertical guides and sinking below the level of the sill (Fig. 38).

<sup>1</sup> Eng. News, Nov. 13, 1913.

To close the lock, compressed air is admitted to an open-bottom chamber in the gate, which forces out the water and causes the gate to rise. To open the lock, the air in this chamber is al-

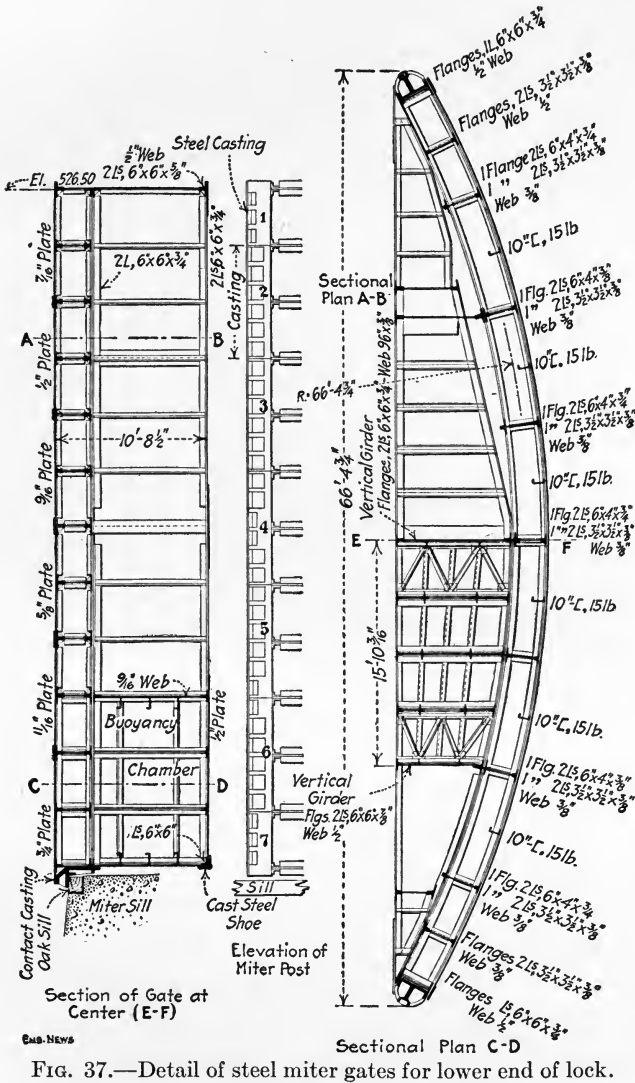

FIG. 37.—Detail of steel miter gates for lower end of lock.

lowed to escape, when the weight of the gate sinks it to its lower position.

The flotation of the gate is controlled by two closed displace-

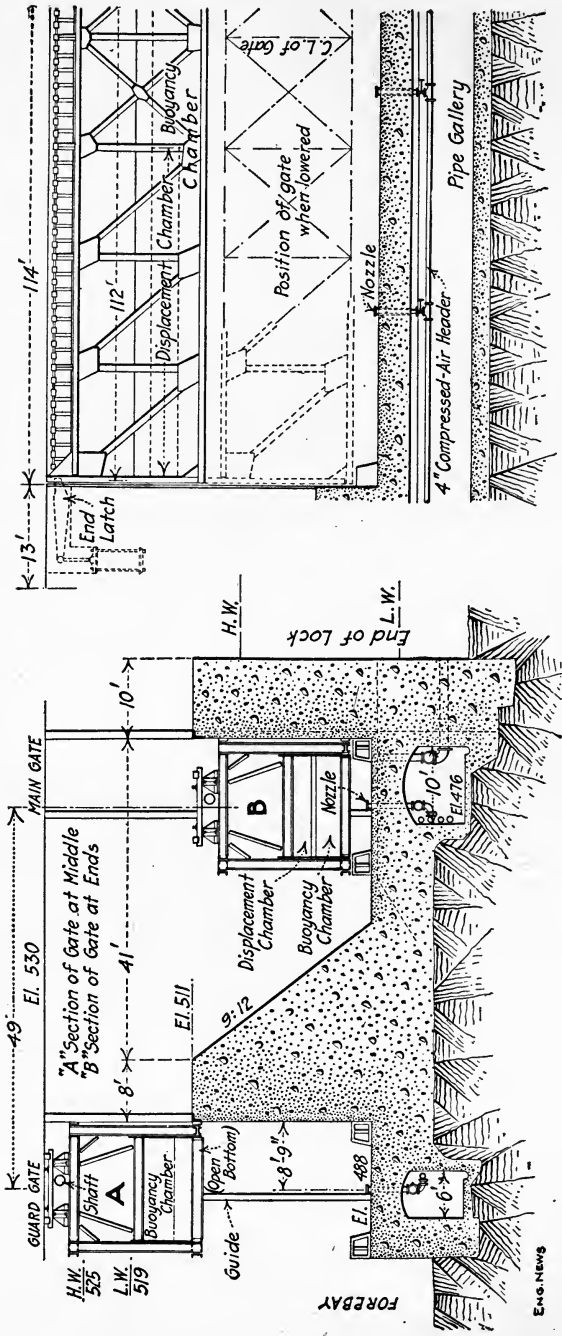

FIG. 38.—Detail of floating gates for dry dock and upper end of lock at Keokuk, Iowa.

ENG. NEWS

ment chambers, one at each end, and one open buoyancy chamber. Each of the former is 42 ft. long, 4 ft. deep and 16 ft. wide. The buoyancy chamber is 2-1/2 ft. high beneath the displacement chambers and 6-1/2 ft. high in the 28-ft. space between them, its capacity being 6000 cu. ft.

With the gate floating and its bottom just clear of the sill, the weight of the part above water is 190 tons, which is increased by the ballast in the displacement chambers to 210 tons. The displacement of the submerged part of the gate is 12 tons so that the buoyant effort required is 198 tons.

Find the equivalent displacement in cubic feet, from this result subtract the volume of the displacement chambers, and then find the required air pressure in the buoyancy chamber.

In raising the gate it is actually found that this pressure varies from 2 lb. per square inch to as high as 12 lb. per square inch when the gate is leaving its lower seat.

40. A gas tank is fitted with a mercury gage as shown in Fig. 18. The height  $h$  of the mercury column is 20 in. Find the excess of pressure in the tank above atmospheric.

41. A piece of lead weighs 20 lb. in air. What will be its apparent weight when suspended in water, assuming the specific weight of lead to be 11.4?

42. A pail of water is placed on a platform scales and found to weigh 12 lb. A 6-lb. iron weight is then suspended by a light cord from a spring balance and lowered into the water in the pail until completely immersed. Find the reading on the spring balance and on the platform scales.

43. A brass casting (alloy of copper and zinc) weighs 200 lb. in air and 175 lb. in water. If the specific weight of copper is 8.8 and of zinc is 7, how many pounds of each metal does the casting contain?

44. One end of a wooden pole 12 ft. long, floats on the water and the other end rests on a wall so that 2 ft. project inward beyond the point of support (Fig. 39). If the point of support is 18 in. above the water surface, find how much of the pole is immersed.

45. A floating platform is constructed of two square wooden beams each 16 ft. long, one 18 in. square and the other 1 ft. square. On these is laid a platform of 2-in. plank, 10 ft. wide. Find where a man weighing 160 lb. must stand on the platform to make it float level, and how high its surface will then be above

the water (Fig. 40). The weight of timber may be assumed as 50 lb. per cubic foot.

46. A piece of timber 4 ft. long and 4 in. square has a weight  $W$  attached to its lower end so that it floats in water at an angle of  $45^\circ$  (Fig. 41). Find  $W$ .

47. A rectangular wooden barge is 30 ft. long, 12 ft. wide and 4 ft. deep, outside measurement, and is sheathed with plank

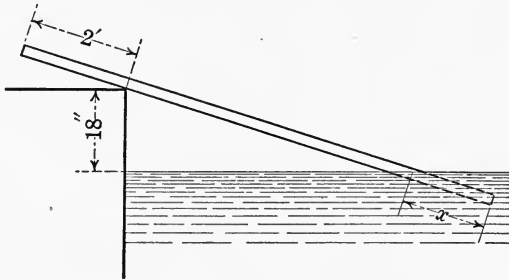

FIG. 39.

3 in. thick, the frame weighing half as much as the planking. Find the position of the water line when the barge floats empty, and also the load in tons it carries when the water line is 1 ft. from the top. Assume the weight of wood as 50 lb. per cubic foot.

48. A prismatic wooden beam 10 ft. long, 1 ft. wide and 6 in. thick floats flat on the water with 4 in. submerged and 2 in. above water. Find its specific weight.

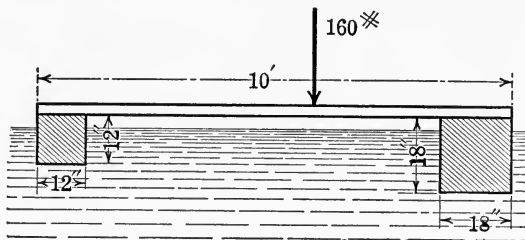

FIG. 40.

49. A dipper dredge weighs 1200 tons and floats on an even keel with bucket extended and empty. When the bucket carries a load of 3 tons at a distance of 50 ft. from the center line of the scow, a plumb line 15 ft. long, suspended from a vertical mast, swings out 5 in. Find the metacentric height.



50. A steamer is of 14,000 tons displacement. When its life boats on one side are filled with water, a plumb line 20 ft. long suspended from a mast is found to swing out  $9\frac{1}{2}$  in. If the

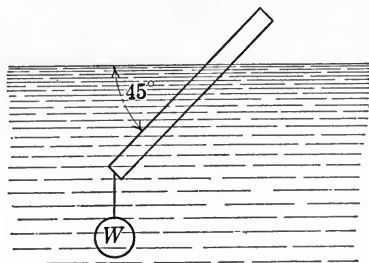

FIG. 41.

total weight of water in the boats is 75 tons and their distance from the center line of the vessel is 25 ft., find the period with which the ship will roll.

## SECTION II

### HYDROKINETICS

#### 8. FLOW OF WATER FROM RESERVOIRS AND TANKS

**Stream Line.**—In the case of a flowing liquid, the path followed by any particle of the liquid in its course is called a *stream line*. In particular, if a reservoir or tank is filled with water and a small opening is made in one side at a depth  $h$  below the surface, the water flows out with a certain velocity depending on the depth, or head,  $h$ . Since the particles of water flowing out converge at the opening, the stream lines inside the vessel are, in general, comparatively far apart, but become crowded more closely together at the orifice.

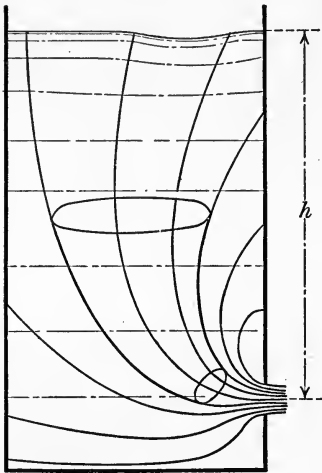

FIG. 42.

**Liquid Vein.**—Under the conditions just considered, suppose that a closed curve is drawn in any horizontal cross section of the vessel and through each point of the closed curve draw a stream line. The totality of all these stream lines will then form a tube, called a *liquid vein* (Fig. 42).

From the definition of a stream

line it is evident that the flow through such a tube or vein is the same as though it were an actual material tube. In particular, the same amount of liquid will flow through each cross section of the vein and therefore the velocity of flow will be greatest where the cross section of the vein is least, and *vice versa*.

**Ideal Velocity Head.**—In any particular vein let  $v$  denote the velocity of flow at a distance  $h$  below the surface, and  $Q$  the quantity of water per second flowing through a cross section of the vein at this depth. Then the weight of water flowing through the cross section per second is  $\gamma Q$  and its potential energy at the

height  $h$  is  $\gamma Qh$ . The kinetic energy of this quantity of water flowing at the velocity  $v$  is  $\frac{\gamma Qv^2}{2g}$ . Therefore by equating the potential energy lost to the kinetic energy gained and *neglecting all frictional and other losses* we have

$$\gamma Qh = \frac{\gamma Qv^2}{2g}$$

whence

$$v = \sqrt{2gh}. \quad (22)$$

This relation may also be written in the form

$$h = \frac{v^2}{2g}.$$

The quantity  $h$  is therefore called the *ideal velocity head*, since it is the theoretical head required to produce a velocity of flow  $v$ .

**Torricelli's Theorem.**—The relation

$$v = \sqrt{2gh}$$

is known as *Torricelli's Theorem*. Expressed in words, it says that the ideal velocity of flow under a static head  $h$  is the same as would be acquired by a solid body falling in a vacuum from a height equal to the depth of the opening below the free surface of the liquid.

**Actual Velocity of Flow.**—The viscosity of the liquid, as well as the form and dimensions of the opening, have an important effect in modifying the discharge.

Considering viscosity first, its effect is to reduce the velocity of the issuing liquid below the ideal velocity given by the relation  $v = \sqrt{2gh}$ . It is therefore necessary to modify this relation so as to conform to experiment by introducing an empirical constant called a *velocity coefficient*. Denoting this coefficient by  $C_v$ , the expression for the velocity becomes

$$v = C_v \sqrt{2gh}. \quad (23)$$

For water the value of the velocity (or viscosity) coefficient for an orifice or a nozzle is approximately  $C_v = 0.97$ .

**Contraction Coefficient.**—In the case of flow through an orifice or over a weir, the oblique pressure of the water approaching from various directions causes a contraction of the jet or stream so that the cross section of the jet just outside the orifice is some-

what less than the area of the opening. Consequently the discharge is also less than it would be if the jet were the full size of the opening.

If the area of the orifice is denoted by  $A$ , the area of the jet at the contracted section will be some fraction of this amount, say  $C_c A$ , where  $C_c$  is an empirical constant called a *contraction coefficient*, which must be determined experimentally for openings of various forms and dimensions.

**Efflux Coefficient.**—Taking into account both the viscosity of the liquid and the contraction of the jet, the formula for discharge becomes

$$\begin{aligned} Q &= \text{actual velocity} \times \text{area of jet} \\ &= (C_v \sqrt{2gh}) \times (C_c A) \\ &= C_v C_c A \sqrt{2gh}, \end{aligned}$$

where  $A$  denotes the area of the orifice. Since there is no object in determining  $C_v$  and  $C_c$  separately, they are usually replaced by

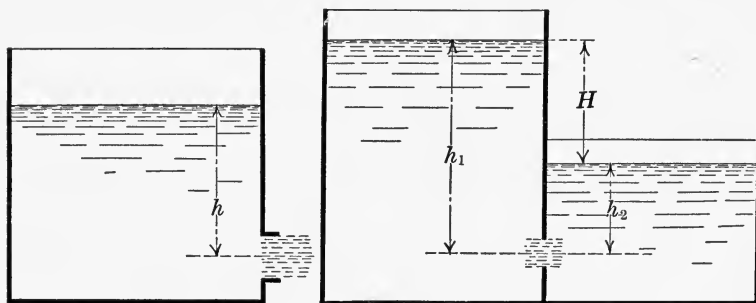

FIG. 43.

FIG. 44.

a single empirical constant  $K = C_v C_c$ , called the *coefficient of efflux*, or discharge. In general, therefore, the formula for the actual discharge becomes

$$Q = KA \sqrt{2gh}. \quad (24)$$

**Effective Head.**—The head  $h$  may be the actual head of water on the orifice; or if the vessel is closed and the pressure is produced by steam or compressed air, the effective head is the height to which the given pressure would sustain a column of water.

The height of the equivalent water column corresponding to any given pressure may be determined by calculating the weight

of a column of water 1 ft. high and 1 sq. in. in section, from which it is found that

$$1 \text{ ft. head} = 0.434 \text{ lb./in.}^2 \text{ pressure,}$$

and conversely,

$$1 \text{ lb./in.}^2 \text{ pressure} = 2.304 \text{ ft. head.}$$

For an orifice in the bottom of a vessel, the head  $h$  is of course the same at every point of the opening, but if the orifice is in the side of the vessel, the head  $h$  varies with the depth. However, if the depth of the opening is small in comparison with  $h$ , as is frequently the case, the head may be assumed to be constant over the entire orifice and equal to the distance of its center of gravity from the free surface of the liquid (Fig. 43).

If an orifice is entirely submerged, as shown in Fig. 44, the effective head on it is the difference in level between the water surfaces on the two sides of the opening.

**Discharge from Large Rectangular Orifice.**—In the case of a comparatively large orifice, the effective head is not the depth of

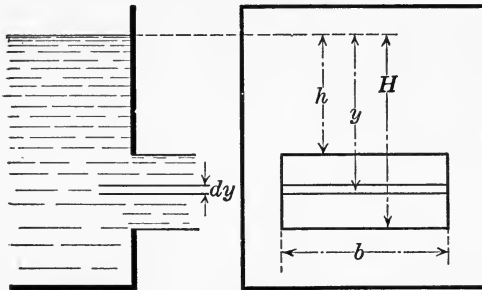

FIG. 45.

its center of gravity below the surface, and the discharge must be determined in a different manner.

To illustrate the method of procedure consider the particular case of an orifice in the form of a rectangle of breadth  $b$ , the upper and lower edges being horizontal and at depths of  $h$  and  $H$  respectively below the surface, as shown in Fig. 45. Let this rectangle be divided up into narrow horizontal strips, each of breadth  $b$  and depth  $dy$ . Then the ideal velocity of flow in any one of these strips at a distance  $y$  below the surface is  $v = \sqrt{2gy}$ ,

and since its area is  $b dy$ , the ideal discharge  $dQ$  through this elementary area per second is

$$dQ = b dy \sqrt{2gy}.$$

The total discharge per second,  $Q$ , through the entire orifice is therefore

$$Q = Kb \int_h^H \sqrt{2gy} \, dy = \frac{2}{3} Kb \sqrt{2g} (H^{3/2} - h^{3/2}). \quad (25)$$

This expression may also be written in the form

$$Q = \frac{2}{3} K b H \sqrt{2gH} - \frac{2}{3} K b h \sqrt{2gh}$$

which makes it easier to remember from analogy with the weir formula which follows.

**Discharge of a Rectangular Notch Weir.**—If the upper edge of the rectangular orifice just considered coincides with the water surface, the opening is called a *rectangular notch weir*. In this case  $h = 0$  and the preceding formula for discharge becomes

$$Q = \frac{2}{3} K b H \sqrt{2gH} = \frac{2}{3} KA \sqrt{2gH} \quad (26)$$

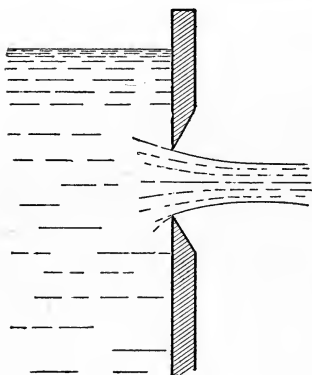

FIG. 46.

where  $H$  denotes the head on the crest of the weir, and  $A$  is the area of that part of the opening which lies below the surface.

## 9. DISCHARGE THROUGH SHARP-EDGED ORIFICE

**Contraction of Jet.**—In considering the flow of water through an orifice it is assumed in what follows that a sharp-edged orifice is meant, that is, one in which the jet is in contact with the wall of the vessel

along a line only (Fig. 46). When this is not the case, the opening is called an *adjuster* or *mouthpiece*, and the flow is modified, owing to various causes, as explained in Art. 13.

The value of the constant  $K$  in Eq. (26) depends on the form of the opening and also on the nature of the contraction of the jet. The contraction is said to be *complete* when it takes place

on all sides of the jet; that is to say, when the size of the opening is small in comparison with its distance from the sides and bottom of the vessel and from the water surface. The contraction is called *incomplete* when one or more of the edges of the orifice is continuous with the sides of the vessel.

**Complete Contraction.**—For a sharp-edged orifice with complete contraction the mean value of the efflux coefficient  $K$  is

$$K = 0.62.$$

The actual value of this coefficient varies slightly with the size of the orifice and effective head on it. The value given, however, is sufficiently accurate for all ordinary practical calculations. More exact values are given in Tables 9 and 10.

**Partial Contraction.**—In the case of incomplete contraction, let  $P$  denote the entire perimeter of the orifice, and  $nP$  that fraction of the perimeter which experiences no contraction. Then denoting the coefficient of efflux by  $K_1$ , its value as determined by experiment for sharp-edged orifices is as follows:

$$\left. \begin{array}{l} \text{Rectangular orifice, } K_1 = K(1 + 0.15n) \\ \text{Circular orifice, } K_1 = K(1 + 0.13n) \end{array} \right\} \quad (27)$$

Assuming  $K = 0.62$ , the following table gives the corresponding values of  $K_1$  as determined from these relations.<sup>1</sup>

	$n = \frac{1}{4}$	$n = \frac{1}{2}$	$n = \frac{3}{4}$
Rectangular orifice.....	$K_1 = 0.643$	$K_1 = 0.667$	$K_1 = 0.690$
Circular orifice.....	$K_1 = 0.640$	$K_1 = 0.660$	$K_1 = 0.680$

**Velocity of Approach.**—So far it has been assumed that the effective head  $h$  in the formula for discharge through an orifice, namely

$$Q = KA \sqrt{2gh},$$

is simply the static head, measured from the center of the orifice, if it is small, to the surface level. If the velocity of approach is considerable, however, the velocity head must also be included in the effective head. Thus let

$A$  = area of orifice,

$A'$  = cross section of channel of approach,

$V$  = ideal velocity corresponding to the total head  $H$ ,

<sup>1</sup>Lauenstein, *Mechanik*, p. 173.

$v$  = velocity of approach,

$h'$  = velocity head =  $\frac{v^2}{2g}$ ,

$h$  = static head,

$H$  = effective head =  $\frac{V^2}{2g}$ .

Since the total flow through the channel of approach must equal the discharge through the orifice, we have

$$A'v = Q = KAV$$

whence

$$v = \frac{KAV}{A'}$$

Also the effective head  $H = h + h'$ , or, expressed in terms of the velocities,

$$\frac{V^2}{2g} = h + \frac{v^2}{2g}$$

Substituting  $v = \frac{KAV}{A'}$  in this relation, it becomes

$$\frac{V^2}{2g} = h + \frac{K^2 A^2 V^2}{2g A'^2}$$

whence

$$V = \sqrt{\frac{2gh}{1 - K^2 \left(\frac{A}{A'}\right)^2}}$$

The expression for the discharge  $Q$  is then

$$Q = KAV = KA \sqrt{\frac{2gh}{1 - K^2 \left(\frac{A}{A'}\right)^2}} \quad (28)$$

From this relation it is evident that if the area  $A$  of the orifice is small in comparison with the cross section  $A'$  of the channel, say  $A'$  not less than fifteen times  $A$ , the error due to neglecting the velocity of approach will be negligible; that is, the term  $K^2 \left(\frac{A}{A'}\right)^2$

in Eq. (28) may be neglected, in which case the formula for the discharge simplifies into the original expression given by Eq. (26), namely,

$$Q = KA \sqrt{2gh}.$$



## 10. RECTANGULAR NOTCH WEIRS

**Contracted Weir.**—The most common type of weir consists of a rectangular notch cut in the upper edge of a vertical wall, and is called a *contracted weir* (Fig. 47). In order that the contraction shall be complete, there should be a clearance of not less than  $3h$  from the sides of the notch to the sides of the channel, and from the bottom of the notch (called the *crest* of the weir) to the bottom of the channel.

**Suppressed Weir.**—If the sides of the notch are continuous with the sides of the channel, it is called a *suppressed weir* (Fig. 48).

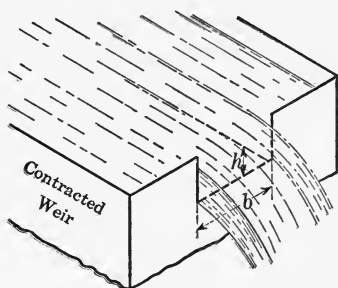

FIG. 47.

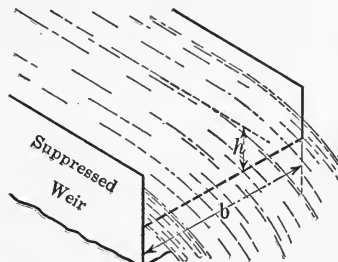

FIG. 48.

For both types of weir it has been found by experiment that the velocity of approach may be neglected when the product  $bh$  is less than one-sixth the cross section of the channel. For a suppressed weir this is equivalent to saying that the height of the weir crest above the bottom should be at least five times the head on the weir.

**Empirical Weir Formulas.**—Numerous experiments have been made on the flow of water over weirs for the purpose of deriving an empirical formula for the discharge. The most important of these results, including the formulas in common use, are tabulated on page 52. Although these formulas apparently differ somewhat in form, they are found in practice to give results which agree very closely.

**Rational Weir Formula.**—A rational formula for the discharge over a weir was derived in Art. 8, as expressed by Eq. (26), namely,

$$Q = \frac{2}{3}KA\sqrt{2gh}.$$

## EMPIRICAL FORMULAS FOR RECTANGULAR NOTCH WEIRS

Experimenter	Contracted weirs (Fig. 28).		Suppressed weirs (Fig. 29).	
	Velocity of approach, negligible	Vel. of approach = $V$ Vel. head $H = \frac{V^2}{2g}$	Velocity of approach, negligible	Vel. of approach = $V$ Vel. head $H = \frac{V^2}{2g}$
James B. Francis, 1851 <sup>1</sup> Length 10 ft. Head 0.6 to 1.6 ft.	$Q = 3.33 \left( b - \frac{2h}{10} \right) h^{3/2}$	$Q = 3.33 \left( b - \frac{2h}{10} \right) [(h + H)^{3/2} - H^{3/2}]$	$Q = 3.33 bh^{3/2}$	$Q = 3.33b[(h + H)^{3/2} - H^{3/2}]$
Pfley and Stearns, 1877, 1880 <sup>2</sup> Length 5 to 20 ft. Head 0.07 to 1.63 ft.			$Q = 3.31bh^{3/2} + 0.007b$	$Q = 3.31b(h + 1.5H)^{3/2} + 0.007b$
H. Bazin, 1888 <sup>3</sup> Length 1.64 to 6.56 ft. Head 0.164 to 1.969 ft.			$Q = C_1 bh \sqrt{2gh}$ $C_1 = 0.405 + \frac{0.00984}{h}$	$Q = C_1 C_2 bh \sqrt{2gh}$ $C_2 = 1 + 0.55 \left( \frac{h}{d + h} \right)^2$ $d =$ height of crest of weir above bottom of channel.
Hamilton Smith, Jr., 1886 <sup>4</sup> Résumé of work of various experimenters	$Q = \frac{2}{3} K bh \sqrt{2gh}$ For values of $K$ see Table 16	$Q = \frac{2}{3} Kb \sqrt{2g}(h + 1.4H)^{3/2}$ For values of $K$ see Table 16	$Q = \frac{2}{3} C bh \sqrt{2gh}$ For values of $C$ see Table 19	$Q = \frac{2}{3} Cb \sqrt{2g}(h + \frac{1}{3}H)^{3/2}$ For values of $C$ see Table 19

<sup>1</sup> Lowell Hydraulic Experiments, Van Nostrand, N. Y., 1868.<sup>2</sup> Flow of Water over Weirs, Trans. Am. Soc. C. E., 1883, Vol. 12.<sup>3</sup> Annales des Ponts et Chaussées, 1898, Tr. by Rafter, Trans. Am. Soc. C. E., 1900, Vol. 44.<sup>4</sup> Hamilton Smith, Jr., Hydraulics.

For a sharp-edged opening the mean value of the efflux coefficient is  $K = 0.62$ , as stated in Art. 9. In the present case, therefore,  $KA = 0.62bh$ , and if  $b$  and  $h$  are expressed in feet, the above formula becomes

$$\begin{aligned} Q &= \frac{2}{3}(0.62 bh)\sqrt{2gh}, \\ &= 3.3bh^{3/2} \text{ cu. ft. per sec.} \end{aligned} \quad (29)$$

It is often convenient to express  $b$  and  $h$  in inches, and the discharge  $Q$  in cubic feet per minute. Expressed in these units, the formula becomes

$$Q = \frac{2}{3}(0.62 \frac{bh}{144})\sqrt{\frac{2gh}{12}} \times 60,$$

or, reducing and simplifying,

$$Q = 0.4bh^{3/2} \text{ cu. ft. per min.} \quad (30)$$

where  $b$  and  $h$  are both expressed in inches. These formulas are the basis of many of the weir tables used in practical work, such as Tables 17 and 18 in this book.

## 11. STANDARD WEIR MEASUREMENTS

**Construction of Weir.**—From the experiments summarized in the preceding article it was found that any empirical weir formula could only be relied upon to give accurate results when the conditions under which the measurement was made were approximately the same as those under which the formula was deduced. To obtain accurate results from weir measurements it is therefore customary to construct the weir according to certain standard specifications, as follows:

1. A rectangular notch weir is constructed with its edges sharply beveled toward the intake, as shown in Fig. 49. The bottom of the notch, called the crest of the weir, must be perfectly level and the sides vertical.

2. The length, or width, of the weir should be between four and eight times the depth of water flowing over the crest of the weir.

3. The channel or pond back of the weir should be at least 50 per cent. wider than the notch, and of sufficient depth so that the velocity of approach shall not be over 1 ft. per second. In general it is sufficient if the area  $bh$  is not over one-sixth the area

of the channel section where  $b$  denotes the width of the notch and  $h$  the head of water on the crest.

4. To make the end contractions complete there must be a clearance of from  $2h$  to  $3h$  between each side of the notch and the corresponding side of the channel.

5. The head  $h$  must be accurately measured. This is usually accomplished by means of an instrument called a *hook gage* (Fig. 50), located as explained below. For rough work, however,

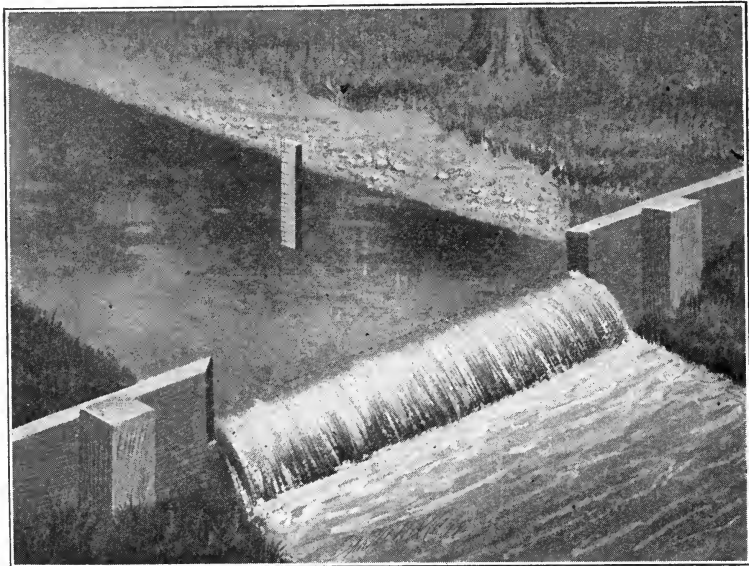

FIG. 49.

the head may be measured by a graduated rod or scale, set back of the weir at a distance not less than the length of the notch, with its zero on a level with the crest of the weir (Fig. 49).

**Hook Gage.**—As usually constructed, the hook gage consists of a wooden or metal frame carrying in a groove a metallic sliding scale graduated to feet and hundredths, which is raised and lowered by means of a milled head nut at the top (Fig. 50). By means of a vernier attached to the frame, the scale may be read to thousandths of a foot. The lower end of the frame carries a sharp-pointed brass hook, from which the instrument gets its name.

In use, the hook gage is set up in the channel above the weir and leveled by means of a leveling instrument so that the scale

reads zero when the point of the hook is at the exact level of the crest of the weir. The hook is then raised until its point just reaches the surface, causing a distortion in the reflection of light from the surface of the water. If slightly lowered the distortion disappears, thus indicating the surface level with precision. The reading of the vernier on the scale then gives the head on the crest to thousandths of a foot.

**Location of Hook Gage.**—To avoid surface oscillations, and thereby obtain more precise readings, the hook gage should be set up in a still box communicating with the channel. The channel end of the opening or pipe leading into the still box must be flush with a flat surface set parallel to the direction of flow, and the pipe itself must be normal to this direction.

The channel end of the pipe must be set far enough above the weir to avoid the slope of the surface curve, but not so far as to increase the head by the natural slope of the stream.

If the formula of any particular experimenter is to be used, his location for the still box should be duplicated.

**Proportioning Weirs.**—To illustrate the method of proportioning a weir, suppose that the stream to be measured is 5-1/2 ft. wide and 1-1/2 ft. deep, and that its average velocity, determined by timing a float over a measured distance or by using a current meter or a Pitot tube (Arts. 26 and 27), is approximately 4 ft. per second.

The flow is then approximately 1980 cu. ft. per minute. To determine the size of weir which will flow approximately this amount, try first a depth of say 10 in. From Table 17 it is found that each inch of length for this depth will deliver 12.64 cu. ft. per minute. The required length of weir would

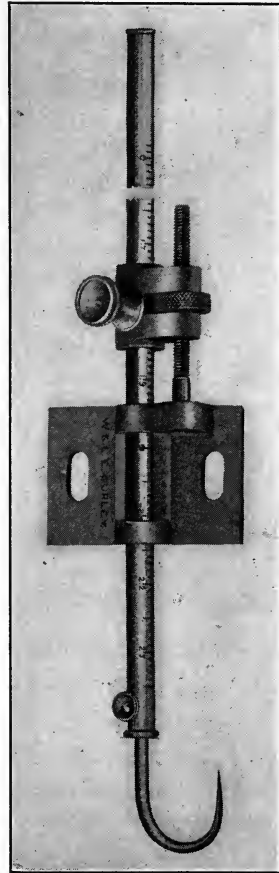

FIG. 50.—Hook gage.

then be  $\frac{1980}{12.64} = 156.6$ , which is fifteen and two-thirds times the depth and therefore too long by Rule 2 of the specifications.

Since the weir must evidently be deeper, try 18 in. From the table the discharge per linear inch for this depth is 30.54 cu. ft. per minute, and consequently the required length would be  $\frac{1980}{30.54} = 64.8$  in., which is now only 3.6 times the depth and therefore too short.

By further trial it is found that a depth of 15 in. gives a length of  $\frac{1980}{23.23} = 85.2$  in., which is 5.7 times the depth and therefore comes within the limits required by Rule 2.

Suppose then that the notch is made 7 ft. long and say 20 in. deep, so that the depth may be increased over the calculated amount if necessary. If then the width of the pond back of the weir is not 50 per cent. greater than the width of the notch, or if the velocity of flow should be in excess of 1 ft. per second, the pond should, if possible, be enlarged or deepened to give the desired result. With the weir so constructed suppose that the depth of water over the stake back of the weir is found to be 15-1/8 in. From the table the discharge per linear inch corresponding to this head is found to be 23.52 cu. ft. per minute, and this multiplied by 84, the length of the weir in inches, gives 1975.7 cu. ft. per minute for the actual measured discharge.

## 12. TIME REQUIRED FOR FILLING AND EMPTYING TANKS

**Change in Level under Constant Head.**—To find the time required to raise or lower the water level in a tank, reservoir, or lock, let  $A$  denote the area of the orifice through which the flow takes place and  $K$  its coefficient of discharge or efflux. Several simple cases will be considered.

The simplest case is that in which the water level in a tank is raised, say from  $AB$  to  $CD$  (Fig. 51), by water flowing in under a constant head  $h$ . Let  $V$  denote the total volume of water flowing in, represented in cross section by the area  $ABCD$  in the figure. Then since the discharge  $Q$  through the orifice per second is

$$Q = KA \sqrt{2gh},$$

the time  $t$  in seconds required to raise the surface to the level  $CD$  is

$$t = \frac{V}{Q} = \frac{V}{KA \sqrt{2gh}}. \quad (31)$$

**Varying Head.**—It is often necessary to find the time required to empty a tank or reservoir, or raise or lower its level a certain amount. A common case is that in which the level is to be raised or lowered from  $AB$  to  $CD$  (Fig. 52) by flow through a submerged orifice, the head on one side,  $EF$ , of the orifice being constant. If the cross section of the tank is variable, let  $Y$  denote its area at any section  $mn$ . In the time  $dt$  the level changes from the height  $y$  to  $y - dy$ , and consequently the volume changes by the amount

$$dV = Ydy.$$

But by considering the flow through the orifice, of area  $A$ , the volume of flow in the time  $dt$  is

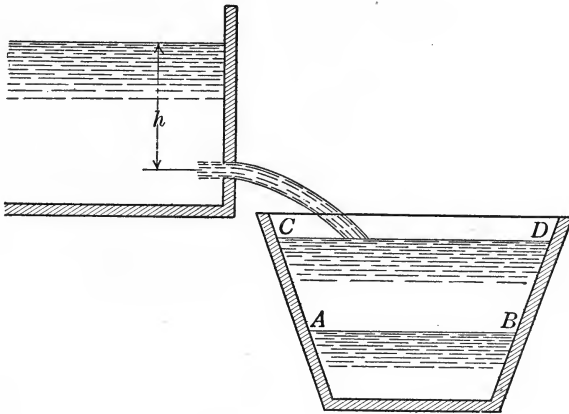

FIG. 51.

$$dV = KA \sqrt{2gy} dt.$$

Hence, by equating these values of  $dV$ , we obtain the relation

$$KA \sqrt{2gy} dt = Ydy$$

whence

$$t = \frac{1}{KA \sqrt{2g}} \int_h^H \frac{dy}{\sqrt{y}} \tag{32}$$

**Canal Lock.**—A practical application of Eq. (32) is in finding the time required to fill or empty a canal lock. For an

ordinary rectangular lock of breadth  $b$  and length  $l$ , the cross section is constant, namely  $Y = bl$ , and consequently the expression for the time integrates into

$$t = \frac{bl}{KA\sqrt{2g}} \int_h^H \frac{dy}{\sqrt{y}} = \frac{bl\sqrt{2}}{KA\sqrt{g}} (\sqrt{H} - \sqrt{h}). \quad (33)$$

**Rise and Fall in Connected Tanks.**—When one tank discharges into another without any additional supply from outside, the

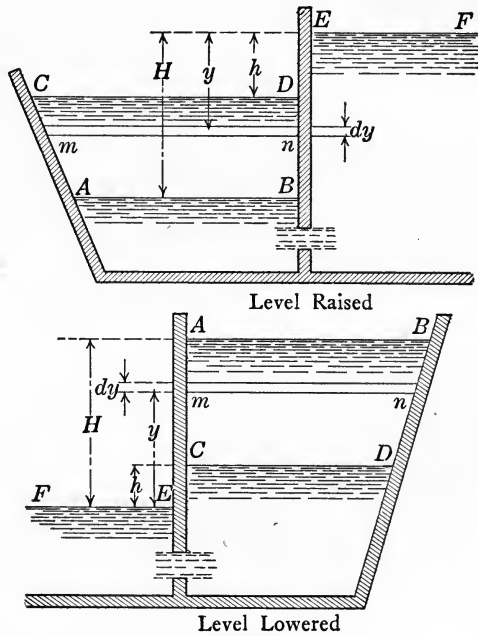

FIG. 52.

level in one tank falls as that in the other rises. If both tanks are of constant cross section, then when the level in one tank has been lowered a distance  $y$ , that in the other tank will have been raised a distance  $y'$  (Fig. 53), such that if  $M$  and  $N$  denote their sectional areas, respectively,

$$My = Ny'.$$



In the interval of time  $dt$  suppose  $y$  changes to  $y + dy$ . Then considering the flow through the orifice of area  $A$ , as in the preceding case, we have

$$Mdy = KA\sqrt{2g[H - (y + y')] }dt,$$

or, since  $y' = \frac{My}{N}$ , this may be written

$$dt = \frac{Mdy\sqrt{N}}{KA\sqrt{2g[NH - y(M + N)]}}$$

Simplifying this expression and integrating, the resulting expression for the time  $t$  is found to be

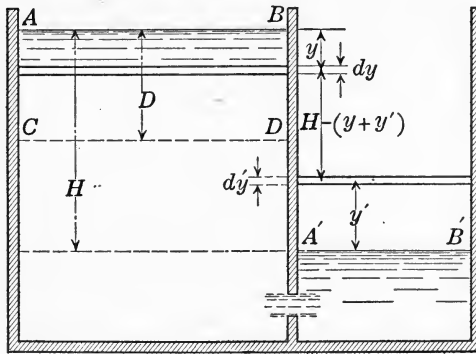

FIG. 53.

$$t = \frac{M\sqrt{N}}{KA\sqrt{2g}} \int_0^D \frac{dy}{\sqrt{NH - y(M + N)}} = \frac{M\sqrt{N}}{KA\sqrt{2g}} \left[ -\frac{2}{M + N} \sqrt{NH - y(M + N)} \right]_0^D$$

Substituting the given limits, the time  $t$  required to lower the level a distance  $D$  is

$$t = \frac{M\sqrt{N}}{KA\sqrt{2g}} \left[ \frac{2}{M + N} \left\{ \sqrt{NH} - \sqrt{NH - D(M + N)} \right\} \right]. \quad (34)$$

When the level becomes the same in both tanks, since the volume discharged by one is received by the other, we have

$$MD = N(H - D),$$

or

$$D = \frac{NH}{M + N}.$$

Substituting this value of  $D$  in Eq. (34), it becomes

$$t = \frac{2MN\sqrt{H}}{KA\sqrt{2g}(M+N)}, \quad (35)$$

which is therefore the length of time required for the water in the tanks to reach a common level.

**Mariotte's Flask.**—It is sometimes desirable in measuring flow to keep the head constant. It is difficult to accomplish this by keeping the supply constant, a more convenient method being by the arrangement shown in Fig. 54, which is known as *Mariotte's Flask*. This consists of putting an air-tight cover on the tank, having a corked orifice holding a vertical pipe open to the atmos-

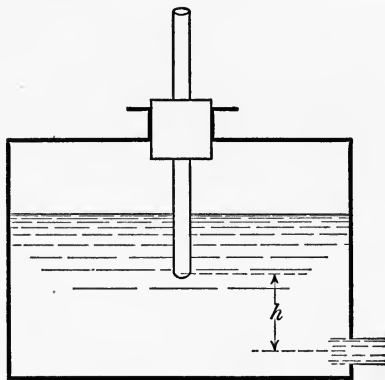

FIG. 54.

phere. Since the pressure at the lower end  $A$  of the tube is always atmospheric, the flow is the same as though the water level was constantly maintained at this height. Therefore as long as the water level does not sink below the bottom of the pipe, the effective head on the orifice is its distance  $h$  below the bottom of the pipe, and the discharge is given by the formula

$$Q = KA\sqrt{2gh}. \quad (36)$$

### 13. FLOW THROUGH SHORT TUBES AND NOZZLES

**Standard Mouthpiece.**—When a short tube (adjutage, mouthpiece or nozzle) is added to an orifice, the flow through the opening is changed both in velocity and in amount. In general the velocity is diminished by the mouthpiece, due to increased fric-

tional resistance, whereas the quantity discharged may be either increased or diminished, depending on the form of the mouthpiece.

What is called the *standard mouthpiece* consists of a circular tube projecting outward from a circular orifice, and of length equal to two or three diameters of the orifice (Fig. 56). At the inner end of the tube the jet is contracted as in the case of a standard orifice, but farther out it expands and fills the tube. The velocity of the jet is reduced by this form of mouthpiece to

$$v = 0.82 \sqrt{2gh},$$

which is considerably less than for a standard orifice, but since there is no contraction, the quantity discharged is

$$Q = 0.82A \sqrt{2gh},$$

where  $A$  denotes the area of the orifice. The discharge is therefore nearly one-third larger than for a standard orifice of the same area with complete contraction (Fig. 55).

**Stream-line Mouthpiece.**—By rounding the inner edge of the mouthpiece so that its contour approximates the form of a stream line, the velocity of the jet is greatly increased, its value for the relative dimensions shown in Fig. 57 being about

$$v = 0.96 \sqrt{2gh};$$

and since the jet suffers no contraction, the quantity discharged is

$$Q = 0.96A \sqrt{2gh},$$

the area  $A$ , as before, referring to the area of the orifice.

**Borda Mouthpiece.**—A mouthpiece projecting inward and having a length of only half a diameter is called a *Borda mouthpiece* (Fig. 58). The velocity is greatly increased by this form of mouthpiece, its value being about

$$v = 0.99 \sqrt{2gh},$$

but the contraction of the jet is more than for a standard orifice, so that the discharge is only

$$Q = 0.53A \sqrt{2gh},$$

where  $A$  denotes the area of the orifice.

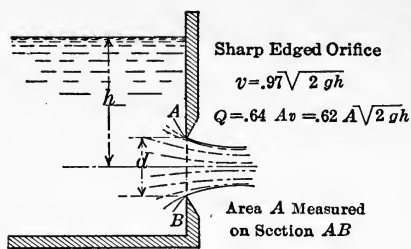

FIG. 55.

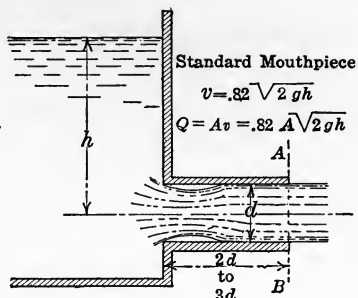

FIG. 56.

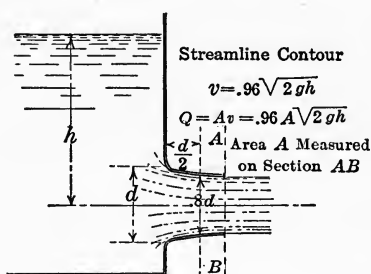

FIG. 57.

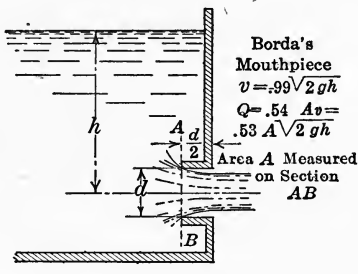

FIG. 58.

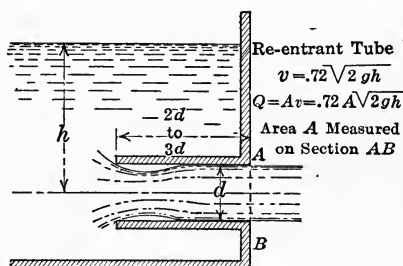

FIG. 59.

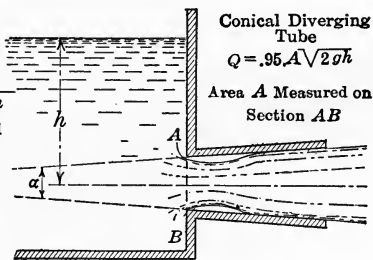

FIG. 60.

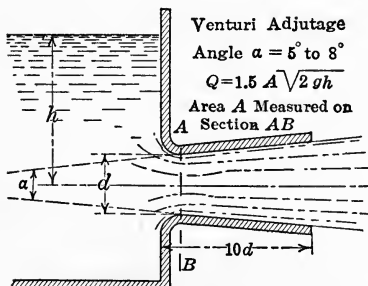

FIG. 61.

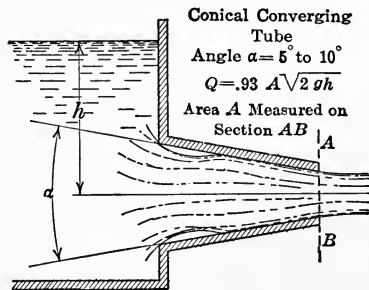
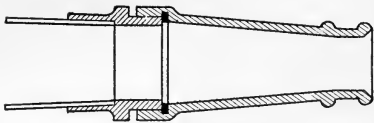

FIG. 62.



Fire Hose; Smooth Cone Nozzle

$$Q = .97 A \sqrt{2gh}$$

FIG. 63.

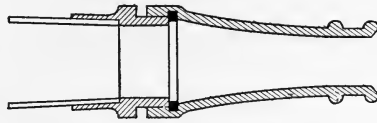

Fire Hose; Smooth Convex Nozzle

$$Q = .97 A \sqrt{2gh}$$

FIG. 64.

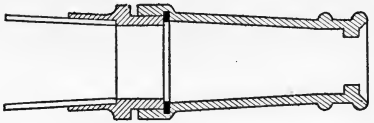

Fire Hose; Square Ring Nozzle

$$Q = .74 A \sqrt{2gh}$$

FIG. 65.

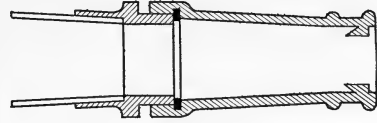

Fire Hose; Undercut Ring Nozzle

$$Q = .71 A \sqrt{2gh}$$

FIG. 66.

If, however, the length of the mouthpiece is increased to two or three diameters (Fig. 59) the discharge is increased nearly 50 per cent., becoming

$$Q = 0.72A \sqrt{2gh}.$$

**Diverging Conical Mouthpiece.**—For a conical diverging tube with sharp edge at entrance (Fig. 60) the jet contracts at the inner end as for an orifice, but farther on expands so as to fill the tube at outlet provided the angle of divergence is not over  $8^\circ$ . The discharge is therefore greater than for a standard mouthpiece, its amount referred to the area  $A$  at the smallest section being

$$Q = 0.95 A \sqrt{2gh}.$$

**Venturi Adjutage.**—If the entrance to a diverging conical mouthpiece has a stream-line contour, it is called a *Venturi adjutage* (Fig. 61). In experiments by Venturi and Eytelwein with diverging mouthpieces of the relative dimensions shown in Fig. 61, a discharge was obtained nearly two and one-half times as great as for a standard orifice of the same diameter as that at the smallest section, or about twice that for a standard short tube

of this diameter, the formula for discharge referred to the area  $A$  at the smallest section being

$$Q = 1.55A\sqrt{2gh}.$$

**Converging Conical Mouthpiece.**—In the case of a conical converging tube with sharp corners at entrance (Fig. 62) the jet contracts on entering and then expands again until it fills the tube, the most contracted section being just beyond the tip, and the greatest discharge occurring for an angle of convergence of approximately  $13^\circ$ .

**Fire Nozzles.**—The fire nozzles shown in Figs. 63, 64, 65 and 66 are practical examples of converging mouthpieces. The smooth cone nozzle with gradually tapering bore has been found to be the most efficient, the coefficient of discharge for the best specimen being 0.977 with an average coefficient for this type of 0.97. For a square ring nozzle like that shown in Fig. 65 the coefficient of discharge is 0.74; and for the undercut type shown in Fig. 66 the coefficient of discharge is 0.71.

#### 14. KINETIC PRESSURE IN A FLOWING LIQUID

**Kinetic Pressure.**—For a liquid at rest, the normal pressure exerted by it on any bounding surface is called the hydrostatic pressure and is given by the expression deduced in Art. 2, namely,

$$p = p' + \gamma h.$$

If a liquid is in motion, however, the normal pressure it exerts on the walls of the vessel containing it, or on the bounding surface of a liquid vein or filament, follows an entirely different law, as shown below.

To distinguish the hydrostatic pressure from the normal pressure exerted on any bounding surface by a liquid in motion, the latter will be called the *kinetic pressure*.

**Bernoulli's Theorem.**—To determine the kinetic pressure at any point in a flowing liquid, consider a small tube or vein of the liquid bounded by stream lines, as explained in Art. 8, and follow the motion of the liquid through this tube for a brief interval of time.

Let  $A$  and  $A'$  denote the areas of two normal cross sections of the vein (Fig. 67). Then since the liquid is assumed to be incompressible, the volume  $Ad$  displaced at one end of the tube

must equal the volume  $A'd'$  displaced at the other end. If  $p$  denotes the average unit pressure on  $A$ , and  $p'$  on  $A'$ , the work done by the pressure on the upper cap,  $A$ , is

$$+ pAd,$$

and that on the lower cap,  $A'$ , is

$$- p'A'd'.$$

Also, if  $h$  denotes their difference in static head, as indicated in Fig. 67, the work done by gravity in the displacement of the volume  $Ad$  a distance  $h$  is

$$\gamma Adh.$$

Since the forces acting on the lateral surface of the vein are normal to this surface they do no work. Assuming, then, the case of steady flow, that is to say, assuming that each particle arriving at a given cross section experiences the same velocity and pressure as that experienced by the preceding particle at this point, so that the velocities  $v$  and  $v'$  through the caps  $A$  and  $A'$  are constant, the change in kinetic energy between these two positions is

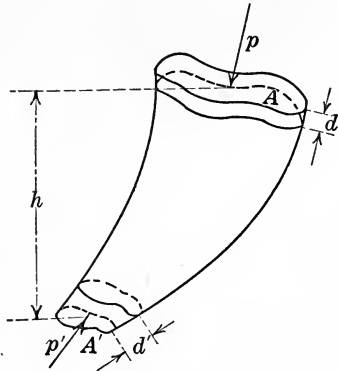

Fig. 67.

$$\frac{\gamma Ad}{2g} (v'^2 - v^2).$$

Therefore, equating the total work done to the change in energy, the result is

$$pAd - p'A'd' + \gamma Adh = \frac{\gamma Ad}{2g} (v'^2 - v^2),$$

or, since  $Ad = A'd'$ , this reduces to

$$p' + \frac{\gamma v'^2}{2g} = p + \frac{\gamma v^2}{2g} + \gamma h. \tag{37}$$

This result is known as *Bernoulli's Theorem*, and shows that in the case of steady parallel flow of an ideal liquid, an increase in velocity at any point is accompanied by a corresponding decrease

in kinetic pressure, or *vice versa*, in accordance with the relation just obtained.

**Kinetic Pressure Head.**—If the theoretic heads corresponding to the velocities  $v$  and  $v'$  are denoted by  $H$  and  $H'$ , respectively, then in accordance with Torricelli's theorem (Art. 8) we have

$$H = \frac{v^2}{2g}; \quad H' = \frac{v'^2}{2g};$$

and consequently Eq. (37) may be written in the form

$$p' = p + \gamma(h + H - H'), \quad (38)$$

which is a convenient form from which to compute the kinetic pressure at any given point.

If this relation is written in the form

$$\frac{p'}{\gamma} + H' = \frac{p}{\gamma} + H + h, \quad (39)$$

then since  $p/\gamma$  is the head corresponding to the hydrostatic pressure  $p$ , each term is a length, and Bernoulli's theorem may be expressed by saying that:

*In the case of steady, parallel flow of an ideal liquid, the sum of the pressure head, velocity head and potential head is a constant quantity for any particle throughout its course.*

**Application to Standard Mouthpiece.**—An illustration of Bernoulli's theorem is afforded by the flow through a standard mouthpiece. At the contracted section  $A$  (Fig. 68) the velocity is evidently greater than at the outlet  $B$ .

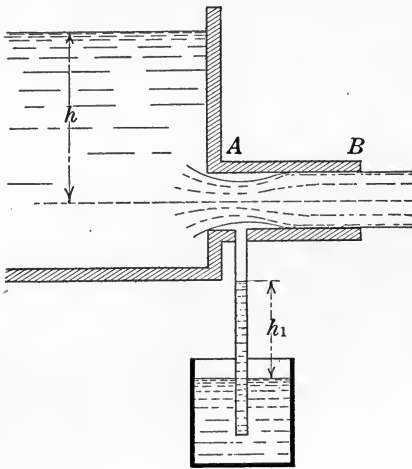

FIG. 68.

Therefore, by Bernoulli's theorem, the kinetic pressure must be less at  $A$  than at  $B$ . Thus if a piezometer is inserted in the mouthpiece at  $A$ , the liquid in it will rise, showing that the pressure in the jet at this point is less than atmospheric. It was found by Venturi, and can also be proved theoretically, that for a standard mouthpiece the negative pressure head at  $A$  is



approximately three-fourths of the static head on the opening, or, referring to Fig. 68,

$$h_1 = \frac{3}{4}h.$$

### 15. VENTURI METER

**Principle of Operation.**—The Venturi meter, invented by Clemens Herschel in 1887 for measuring flow in pipe lines, illustrates an important commercial application of Bernoulli's theorem. This device consists simply of two frustums of conical tubes with their small ends connected by a short cylindrical section, inserted in the pipe line through which the flow is to be measured (Fig. 69). If a pressure gage is inserted in the pipe



FIG. 69.

line at any point *A* and another at the throat of the meter *B*, as indicated in the figure, it will be found that the pressure at *B* is less than at *A*.

**Formula for Flow.**—Let  $v_A$  and  $v_B$  denote the velocities at *A* and *B*, and  $p_A$  and  $p_B$  the kinetic pressures at these points, respectively. Then since both points are under the same static head, Bernoulli's theorem, disregarding frictional losses, gives the relation

$$\frac{v_A^2}{2g} + \frac{p_A}{\gamma} = \frac{v_B^2}{2g} + \frac{p_B}{\gamma}.$$

If  $a$  and  $b$  denote the cross-sectional areas at *A* and *B*, the discharge  $Q$  is given by

$$Q = av_A = bv_B$$

whence

$$v_A = \frac{Q}{a}; \quad v_B = \frac{Q}{b}.$$

Substituting these values of  $v_A$  and  $v_B$  in the preceding equation and solving for  $Q$ , the result is

$$Q = \frac{ab}{\sqrt{a^2 - b^2}} \sqrt{\frac{2g}{\gamma} (p_A - p_B)}.$$

If  $h_A$  and  $h_B$  denote the static piezometer heads corresponding to the kinetic pressures  $p_A$  and  $p_B$ , respectively, this formula may be written

$$Q = \frac{ab}{\sqrt{a^2 - b^2}} \sqrt{2g(h_A - h_B)}. \quad (40)$$

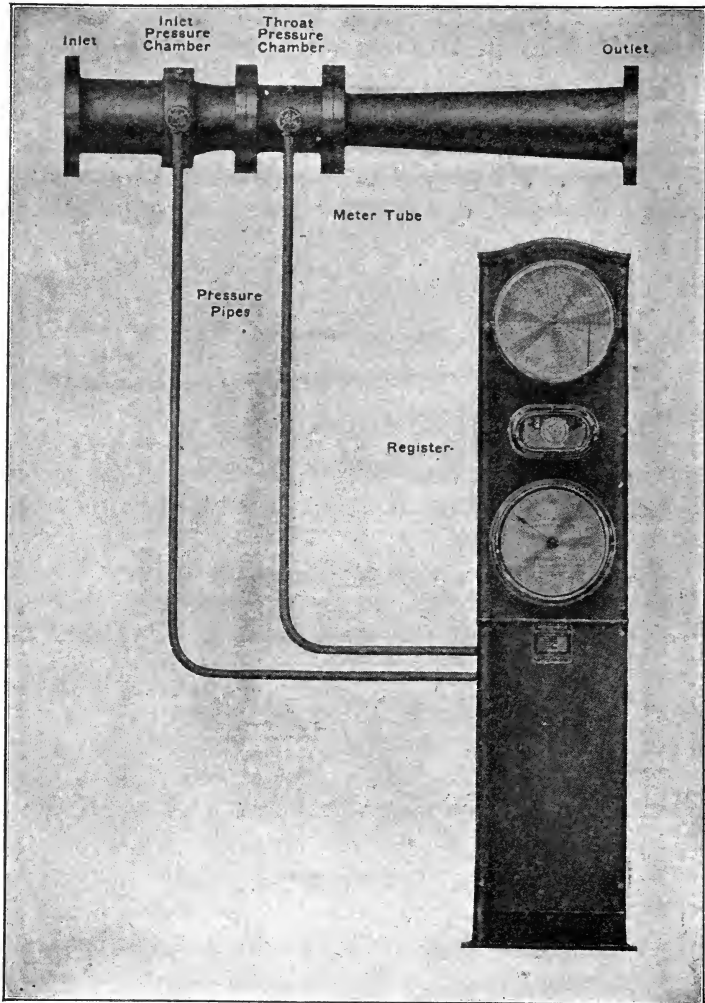

FIG. 70.—Venturi meter and recording gage, manufactured by the Builders Iron Foundry.

Ordinarily the throat diameter in this type of meter is made one-third the diameter of the main pipe, in which case  $a = 9b$ .

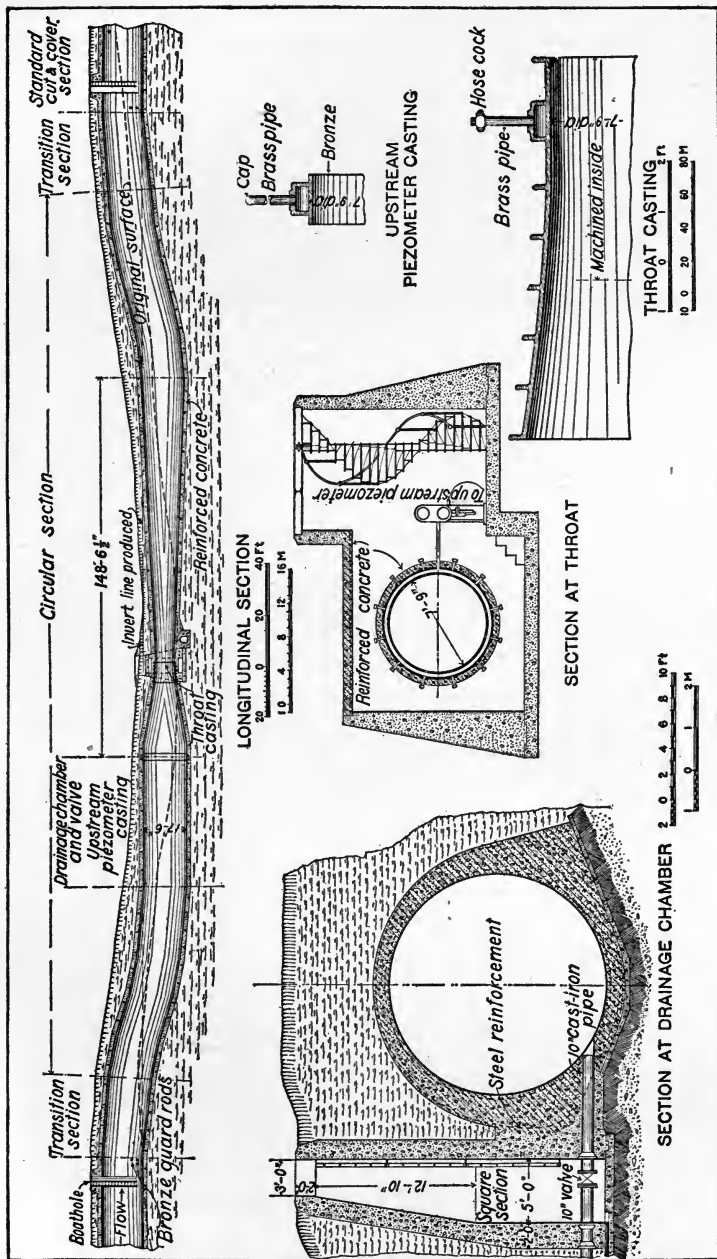

Fig. 71.—Venturi meter, Catskill aqueduct system.

If then,  $h$  denotes the difference in piezometer head between the up-stream end and the throat, the formula for discharge, ignoring frictional losses, becomes

$$Q = 1.0062 b \sqrt{2gh}. \quad (41)$$

By experiment it has been found that ordinarily for all sizes of Venturi meters and actual velocities through them, the actual discharge through the meter is given by the empirical formula

$$Q = (0.97 \pm 0.03)b \sqrt{2gh}. \quad (42)$$

**Commercial Meter.**—A typical arrangement of meter tube and recording apparatus is shown in Fig. 70, the lower dial indicating the rate of flow, and the upper dial making a continuous autographic record of this rate on a circular chart.

**Catskill Aqueduct Meter.**—The Venturi meter affords the most accurate method yet devised for measuring the flow in pipe lines. Fig. 71 shows one of the three large Venturi meters built on

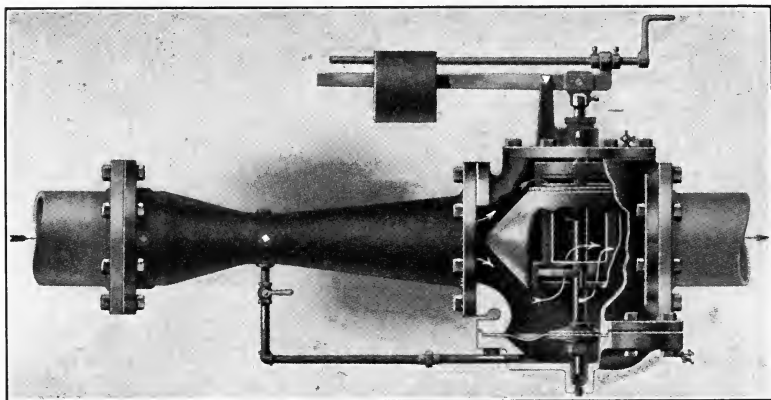

FIG. 72.—Venturi rate of flow controller manufactured by the Simplex Valve and Meter Co.

the line of the Catskill Aqueduct, which is part of the water supply system of the City of New York. Each of these meters is 410 ft. long and is built entirely of reinforced concrete except for the throat castings and piezometer ring, which are of cast bronze. Provision is also made in connection with the City aqueduct for the installation of a Venturi meter upon each connection between the aqueduct and the street distribution pipes.

**Rate of Flow Controller.**—Fig. 72 illustrates a rate of flow controller operated by the difference in pressure in a Venturi tube.

This apparatus is designed for use in a water pipe or conduit through which a constant discharge must be maintained regardless of the head on the valve. It consists of a perfectly balanced valve operated by a diaphragm which is actuated by the difference in pressure between the full and contracted sections of a Venturi tube. The valve and diaphragm are balanced by an adjustable counter-weight, which when set for any required rate of flow will hold the valve discs in the proper position for that flow.

## 16. FLOW OF WATER IN PIPES

**Critical Velocity.**—Innumerable experiments and investigations have been made to determine the laws governing the flow of water in pipes, but so far with only partial success, as no general and universal law has yet been discovered.

Experiments made by Professor Osborne Reynolds have shown that for a pipe of a given diameter there is a certain *critical velocity*, such that if the velocity of flow is less than this critical value, the flow proceeds in parallel filaments with true streamline motion; whereas if this critical value is exceeded, the flow becomes turbulent, that is, broken by whirls and eddies and similar disturbances. The results of Professor Reynold's experiments showed that at a temperature of 60° F. this critical velocity occurred when

$$Dv_a = 0.02$$

where  $D$  denotes the diameter of the pipe in feet and  $v_a$  is the average velocity of flow in feet per second.

For parallel, or non-sinuuous, flow it is possible to give a theoretical explanation of what occurs and deduce the mathematical law governing it, as shown below. No one, however, has yet explained why the flow suddenly becomes turbulent at the critical velocity, or what law governs it subsequently.

**Viscosity Coefficient.**—The loss of energy accompanying pipe flow is due to the internal resistance arising from the viscosity of the liquid. This shear or drag between adjacent filaments is analogous to ordinary friction but follows entirely different laws. Unlike friction between the surfaces of solids, fluid friction has been found by experiment to be dependent on the temperature and the nature of the liquid; independent of the pressure; and, for ordinary velocities at least, approximately proportional to the

difference in velocity between adjacent filaments. When this difference in velocity disappears, the frictional resistance also disappears.

The constant of proportionality required to give a definite numerical value to fluid friction is called the *viscosity coefficient* and will be denoted by  $\mu$ . This coefficient  $\mu$  is an empirical constant determined by experiment, the values tabulated below being the result of experiments made by O. E. Meyer.

Temperature in degrees Fahr.	50°	60°	65°	70°
Viscosity coefficient $\mu$ in $\frac{\text{lb. sec.}}{\text{ft.}^2}$	$32 \times 10^{-6}$	$28 \times 10^{-6}$	$26 \times 10^{-6}$	$24 \times 10^{-6}$

The dimensions of  $\mu$  are, of course, such as to make the equation in which it appears homogeneous in the units involved, as will appear in what follows.

**Parallel (non-sinuou) Flow.**<sup>1</sup>—Consider non-sinuou flow in a straight pipe of uniform circular cross section, that is, at a velocity

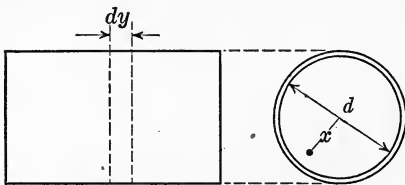

FIG. 73.

less than the critical velocity and therefore such that the filaments or stream lines are all parallel to the axis of the pipe. By reason of symmetry the velocity of any particle depends only on its distance from

the axis of the pipe. Let  $v$  denote the velocity of any particle and  $x$  its distance from the center (Fig. 73). Then if  $x$  changes by an amount  $dx$ , the velocity changes by a corresponding amount  $dv$ , and since the velocity is least near the pipe walls,  $v$  decreases as  $x$  increases and consequently the ratio  $\frac{dv}{dx}$  is negative.

Since the pipe is assumed to be of constant cross section and the flow uniform and parallel, the forces acting on any element of volume must be in equilibrium. Considering therefore a small water cylinder of radius  $x$  and length  $dy$ , in order to equilibrate the frictional resistance acting on the convex surface of this cylinder there must be a difference in pressure on its ends.

<sup>1</sup> The following derivation is substantially that given by Föppl in his *Dynamik*.

This explains the fall in pressure along a pipe, well known by experiment.

Let  $dp$  denote the difference in pressure in a length  $dy$ . Then the difference in pressure on the ends of a cylinder of radius  $x$  is  $(\pi x^2)dp$  and the shear on its convex surface is  $(2\pi x dy)\mu \frac{dv}{dx}$ . Equating these two forces and remembering that  $\frac{dv}{dx}$  is negative, we obtain the relation

$$(\pi x^2)dp = - (2\pi x dy)\mu \frac{dv}{dx}.$$

Also, since the difference in pressure on the ends of any cylinder is proportional to its length, we have

$$\frac{dp}{dy} = \frac{p_1 - p_2}{l} = k,$$

where  $p_1$  and  $p_2$  denote the unit pressures at two sections at a distance  $l$  apart, and the constant ratio is denoted by  $k$  for convenience.

Substituting  $dp = k dy$  from the second equation in the first and cancelling common factors, we have finally

$$\frac{dv}{dx} = - \frac{k}{2\mu} x,$$

whence, by integration,

$$v = - \frac{kx^2}{4\mu} + c,$$

where  $c$  denotes a constant of integration.

To determine  $c$  assume that the frictional resistance between the pipe wall and the liquid follows the same law as that between adjacent filaments of the liquid. Then it follows that the liquid in contact with the pipe must have zero velocity, as otherwise it would experience an infinite resistance. This seems also to be confirmed by the experiments of Professor Hele-Shaw, who showed that in the case of turbulent flow there was always a thin film of liquid adjoining the pipe walls which showed true stream-line motion, proving that its velocity was certainly less than the critical velocity and therefore small. Furthermore, the walls of commercial pipes are comparatively rough and consequently a thin skin or layer of liquid must be caught in these roughnesses and held practically stationary.

Assuming then that  $v = 0$  when  $x = r$ , and substituting this

pair of simultaneous values in the above equation, the value of  $c$  is found to be

$$c = \frac{kr^2}{4\mu}$$

and consequently

$$v = \frac{k}{4\mu} (r^2 - x^2). \quad (43)$$

This is the equation of a parabola, and therefore the velocity diagram is a parabolic arc with its vertex in the axis of the pipe; that is, the velocity is a maximum at the center where  $x = 0$ , its value being

$$v_{max} = \frac{kr^2}{4\mu}.$$

**Average Velocity of Flow in Small Pipes.**—Let the discharge through any cross section of the pipe be denoted by  $Q$ . Then if the velocity at any radius  $x$  is denoted by  $v$ , we have

$$Q = \int_0^r 2\pi x dx v,$$

or, since

$$v = \frac{k}{4\mu} (r^2 - x^2),$$

this becomes

$$Q = \frac{2\pi k}{4\mu} \int_0^r (r^2 x - x^3) dx = \frac{\pi k r^4}{8\mu}.$$

But if  $v_a$  denotes the average velocity of flow we also have

$$Q = v_a (\pi r^2)$$

whence by substituting the above value for  $Q$ , we have

$$v_a = \frac{Q}{\pi r^2} = \frac{\pi k r^4}{8\mu \pi r^2} = \frac{k r^2}{8\mu}.$$

Comparing this expression with that previously obtained for the maximum velocity, it is evident that *the maximum velocity is twice the average velocity of flow.*

**Loss of Head in Small Pipes.**—The loss in pressure in a length  $l$  is given by the relation obtained above, namely,

$$\frac{p_1 - p_2}{l} = k,$$



or, if the difference in head corresponding to this difference in pressure is denoted by  $h$ , then, since  $p = \gamma h$ , we have

$$\text{loss in head, } h = \frac{p_1 - p_2}{\gamma} = \frac{kl}{\gamma}$$

Substituting in this relation the value of  $k$  in terms of the average velocity of flow, the result is

$$h = \frac{8\mu l v_a}{kr^2\gamma} = \frac{2\mu l v_a}{kd^2\gamma} \quad (44)$$

For small pipes, therefore, the loss of head is proportional to the first power of the average velocity, and inversely proportional to the square of the diameter of the pipe.

This result has been verified experimentally for small pipes by the experiments carried out by Poiseuille.

**Ordinary Pipe Flow.**—Under the conditions usually found in practice the velocity of flow exceeds the critical velocity and consequently the flow is turbulent and a greater amount of energy is dissipated in overcoming internal resistance than in the case of parallel flow. The result of Professor Reynold's experiments indicated that the loss of head in turbulent flow was given by the relation

$$h \propto \frac{v_a^{1.72} l}{d}$$

In commercial pipes the degree of roughness is a variable and uncertain quantity, so that the exact loss of head cannot be predicted with accuracy. Practical experiments have shown, however, that ordinarily the loss in head is proportional to the square of the average velocity, so that the relation becomes

$$h \propto \frac{v_a^2 l}{d}$$

Since the theoretical head corresponding to a velocity  $v$  is  $h = \frac{v^2}{2g}$ , the expression for the loss in head for a circular pipe running full may in general be written

$$h \propto \frac{v_a^2 l}{2gd}$$

or, denoting the constant of proportionality by  $f$ , this becomes

$$h = f \frac{l}{d} \cdot \frac{v_a^2}{2g} \quad (45)$$

Here  $f$  is an empirical constant, depending on the condition of the inner surface of the pipe, and is determined by experiment.

Eq. (45) is identical with Chezy's well-known formula

$$v = C \sqrt{rs},$$

as will be shown in Art. 19.

## 17. PRACTICAL FORMULAS FOR LOSS OF HEAD IN PIPE FLOW

**Effective and Lost Head.**—In the case of steady flow through long pipes, much of the available pressure head disappears in frictional and other losses, so that the velocity is greatly diminished. Thus if  $h$  denotes the static head at the outlet and  $h_l$  the head lost in overcoming frictional and other resistances to flow, the velocity  $v$  at the outlet is given by the relation

$$h - h_l = \frac{v^2}{2g},$$

or its equivalent,

$$h = \frac{v^2}{2g} + h_l. \quad (46)$$

The lost head  $h_l$  is the sum of a number of terms, which will be considered separately.

**Loss at Entrance.**—A certain amount of head is lost at the entrance to the pipe, as in the case of a standard adjutage. If  $v$  denotes the velocity due to the head  $h$  with no losses, then

$$h = \frac{v^2}{2g},$$

whereas if  $v_A$  denotes the actual velocity of flow the head corresponding to this velocity is

$$h' = \frac{v_A^2}{2g}.$$

The head,  $h_1$ , lost at entrance, is therefore

$$h_1 = h - h' = \frac{v^2}{2g} - \frac{v_A^2}{2g}.$$

If  $C_v$  denotes the velocity coefficient for the entrance, then

$$v_A = C_v v,$$

and consequently the expression for the head lost at entrance may be written

$$\begin{aligned} h_1 &= \frac{v^2}{2g} - \frac{v_A^2}{2g} = \frac{\left(\frac{v_A}{C_v}\right)^2}{2g} - \frac{v_A^2}{2g} \\ &= \frac{v_A^2}{2g} \left(\frac{1}{C_v^2} - 1\right). \end{aligned}$$

For the standard short tube  $C_v = 0.82$  (Art. 13) and therefore  $\frac{1}{C_v^2} - 1 = \frac{1}{(0.82)^2} - 1 = 0.5$ . The head lost at entrance is therefore

$$h_1 = 0.5 \frac{v^2}{2g}. \quad (47)$$

If the pipe projects into the reservoir,  $C_v = 0.72$  (Art. 13), and the head lost at entrance is thereby increased to

$$h_1 = 0.93 \frac{v^2}{2g}.$$

For ordinary service taps on water mains it may be assumed as

$$h_1 = 0.62 \frac{v^2}{2g}.$$

**Friction Loss.**—In flow through long pipes the greatest loss in head is that due to the friction between the liquid and the walls of the pipe. Let  $d$  denote the internal diameter of the pipe and  $l$  its length. Then it has been found by experiment (Art. 16) that the head lost in internal friction, or *friction head* as it is called, is given by the formula

$$h_2 = f \frac{l}{d} \cdot \frac{v^2}{2g}, \quad (48)$$

the quantity  $f$  being an empirical constant determined by experiment. The average values of this coefficient for cast iron pipes are

$$\begin{aligned} \text{For new smooth pipes, } f &= 0.024; \\ \text{For old rusty pipes, } f &= 0.03. \end{aligned} \quad (49)$$

For more exact values of this coefficient, refer to Table 12.

**Bends and Elbows.**—Bends and elbows in a pipe also greatly diminish the effective head. From experiments by Weisbach

it has been found that the lost head due to a sharp elbow of angle  $\alpha$  (Fig. 74) is given by the formula

$$h_s = m \frac{v^2}{2g}, \quad (50)$$

where  $m$  is a function of the angle  $\alpha$ , given by the equation

$$m = 0.9457 \sin^2 \left( \frac{\alpha}{2} \right) + 2.047 \sin^4 \left( \frac{\alpha}{2} \right).$$

Values of  $m$ , calculated from this formula for various values of the angle  $\alpha$ , are tabulated as follows:

$\alpha =$	20°	30°	40°	50°	60°	70°	80°	90°
$m =$	.046	.073	.139	.234	.364	.533	.740	.984



FIG. 74.

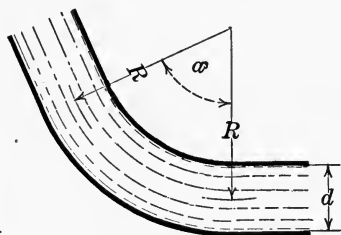

FIG. 75.

For a curved elbow of radius  $R$  and central angle  $\alpha$  (Fig. 75) the lost head is given by the formula

$$h_s = n \left( \frac{\alpha}{90} \right) \frac{v^2}{2g}, \quad (51)$$

where the coefficient  $n$  has the value

$$n = 0.131 + 0.163 \left( \frac{d}{R} \right)^{3.5}.$$

Values of  $n$  calculated from this formula for various values of the ratio  $\frac{d}{R}$  are tabulated below for convenience in substitution.

$\frac{d}{R} =$	.2	.3	.4	.5	.6	.8	1.0	1.2	1.25	1.3	1.4	1.6	1.8	2.0
$n =$	.131	.133	.138	.145	.158	.206	.294	.440	.487	.539	.661	.977	1.40	1.98

**Enlargement of Section.**—A sudden enlargement in the cross section of a pipe decreases the velocity of flow and causes a loss of head due to eddying in the corners, etc. (Fig. 76). If the

velocity is decreased by the enlargement from  $v_1$  to  $v_2$ , it has been found by experiment, and can also be proved theoretically, that the head lost in this way is given by the formula

$$h_4 = \frac{(v_1 - v_2)^2}{2g}. \tag{52}$$

To obtain a more convenient expression for  $h_4$ , let  $a$  denote the

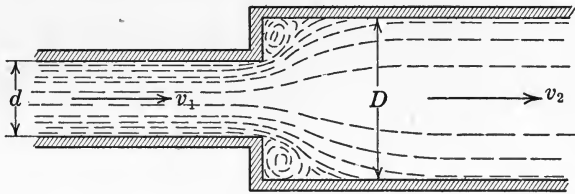

FIG. 76.

area of cross section of the smaller pipe and  $A$  of the larger. Then

$$v_1 a = v_2 A,$$

whence

$$v_1 = \frac{v_2 A}{a},$$

and consequently the expression for  $h_4$  may be written

$$h_4 = \frac{v_2^2}{2g} \left( \frac{A}{a} - 1 \right)^2. \tag{53}$$

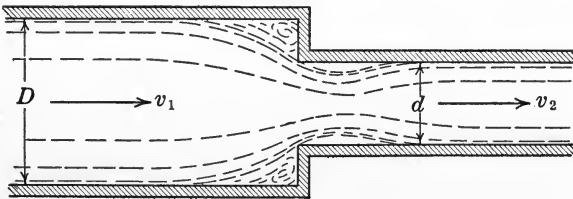

FIG. 77.

**Contraction of Section.**—A sudden contraction in section also causes a loss in head, similar to that due to a standard orifice or adjutage (Fig. 77). The lost head in this case has been found by experiment to be given by the equation

$$h_5 = q \frac{v^2}{2g}, \tag{54}$$

where  $q$  denotes an empirical constant, determined experimentally. The following tabulated values of the coefficient  $q$  are based on experiments by Weisbach,  $A$  being the cross-sectional area of the larger pipe and  $a$  of the smaller.<sup>1</sup>

$\frac{a}{A}$	.1	.2	.3	.4	.5	.6	.7	.8	.9	1.0
$q$	.362	.338	.308	.267	.221	.164	.105	.053	.015	.000

**Gate Valve in Circular Pipe.**—The loss in head due to a partly closed gate valve (Fig. 78) has been determined by experiment for different ratios of height of opening to diameter of pipe with the following results.<sup>2</sup> In this Table,  $x$  denotes the height of the opening,  $d$  the diameter of the pipe,  $h_6$  the loss in head and  $\zeta$  the empirical coefficient in the formula  $h_6 = \zeta \frac{v^2}{2g}$ .

$\frac{x}{d}$	$\frac{1}{8}$	$\frac{1}{4}$	$\frac{3}{8}$	$\frac{1}{2}$	$\frac{5}{8}$	$\frac{3}{4}$	$\frac{7}{8}$
$\zeta$	97.8	17.0	5.52	2.06	0.81	0.26	0.07

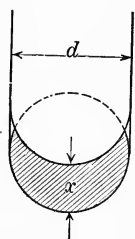

FIG. 78.

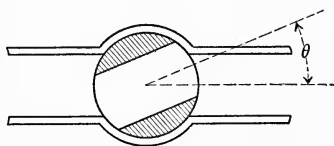

FIG. 79.

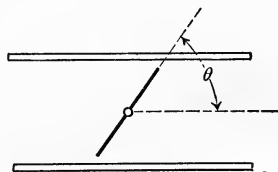

FIG. 80.

**Cock in Circular Pipe.**—For a cock in a cylindrical pipe (Fig. 79) the coefficient  $\zeta$  has been determined in terms of the angle of closure  $\theta$  with the following results.

$\theta$	5°	10°	15°	20°	25°	30°	35°	40°	45°	50°	55°	60°	65°	82°
$\zeta$	.05	.29	.75	1.56	3.1	5.47	9.68	17.3	31.2	52.6	106	206	486	Valve closed

<sup>1</sup> Hoskins, Text-book on Hydraulics, page 74.

<sup>2</sup> The coefficient for losses at valves are based on experiments by Weisbach and are given in most standard texts on Hydraulics. See for example *Wittenbauer, Aufgabensammlung*, Bd. III, S. 318; *Gibson, Hydraulics and its Applications*, pp. 249, 250.

**Throttle Valve in Circular Pipe.**—The coefficient  $\zeta$  in the formula  $h_6 = \zeta \frac{v^2}{2g}$  has been determined experimentally for a throttle valve of the butterfly type (Fig. 80) for various angles of closure with results as follows:

$\theta$	5°	10°	20°	30°	40°	45°	50°	60°	70°
$\zeta$	0.24	0.52	1.54	3.91	10.80	18.70	32.6	118	751

**Summary of Losses.**—The total head,  $h_l$ , lost in flow through a pipe line is then the sum of the six partial losses in head mentioned above, namely

$$h_l = h_1 + h_2 + h_3 + h_4 + h_5 + h_6.$$

The values of these six terms may be tabulated as follows:

Loss of head in pipe flow		
Head lost at entrance	$h_1 = .5 \frac{v^2}{2g}$	Coefficient modified by nature of entrance and varies from .5 to .9
Friction head	$h_2 = f \frac{l}{d} \left( \frac{v^2}{2g} \right)$	New pipe, $f = .024$ Old pipe, $f = .03$ See table 12
Head lost at bends and elbows	$h_3 = m \frac{v^2}{2g}$ (Sharp bend) $h_3 = n \left( \frac{\alpha}{90} \right) \frac{v^2}{2g}$ (Curved elbow)	$m = .9457 \sin^2 \frac{\alpha}{2} + 2.047 \sin^4 \left( \frac{\alpha}{2} \right)$ $n = .131 + .163 \left( \frac{d}{R} \right)^{3.5}$
Head lost at sudden enlargement	$h_4 = \frac{(v_1 - v_2)^2}{2g}$	
Head lost at sudden contraction	$h_5 = q \frac{v^2}{2g}$	For values of coefficient, see Table page 80
Head lost at partially closed valve	$h_6 = \zeta \frac{v^2}{2g}$	See Tabular values of $\zeta$ , pages 80 and 81

From Eq. (36) we have

$$h = \frac{v^2}{2g} + h_l = \frac{v^2}{2g} + h_1 + h_2 + h_3 + h_4 + h_5 + h_6,$$

and inserting in this relation the values tabulated above and solving for the velocity of flow,  $v$ , we have

$$v = \sqrt{\frac{2gh}{1 + 0.5 + f \left( \frac{l}{d} \right) + \left\{ \begin{matrix} m \\ \text{or} \\ n \end{matrix} \left( \frac{\alpha}{90} \right) \right\} + \left( \frac{A}{a} - 1 \right)^2 + q + \zeta}} \quad (55)$$

**Application.**—To give a simple illustration of the application of Formula (55), suppose it is required to find the velocity of flow for a straight new cast iron pipe, 1 ft. in diameter and 5000 ft. long, with no valve obstructions, which conducts water from a reservoir the surface of which is 150 ft. above the outlet of the pipe.

In this case

$$v = \sqrt{\frac{2gh}{1 + 0.5 + k\left(\frac{l}{d}\right)}} = \sqrt{\frac{2(32.2)150}{1 + 0.5 + 0.024\left(\frac{5000}{1}\right)}} = 8.9 \text{ ft. per sec.}$$

and the discharge is

$$Q = Av = \frac{\pi}{4} \times 8.9 \times 60 = 419.4 \text{ cu. ft. per min.}$$

### 18. HYDRAULIC GRADIENT

**Kinetic Pressure Head.**—In the case of steady flow through a long pipe, if open piezometer tubes are inserted at different points of its length and at right angles to the pipe, the height at

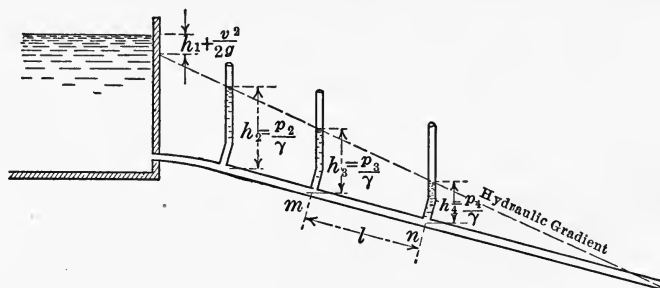

FIG. 81.

which the water stands in any tube represents the kinetic pressure head at this point. Assuming that the pipe is straight and of uniform cross section, the velocity head is constant throughout, and therefore as the frictional head increases the pressure head decreases. The head lost in friction between any two points  $m$  and  $n$  (Fig. 81) as given by Eq. (48), Art. 17, is

$$h = f \left(\frac{l}{d}\right) \frac{v^2}{2g},$$

and is therefore proportional to the distance  $l$  between these points. Consequently, the drop in the piezometer column between any two points is proportional to their distance apart, and



therefore the tops of these columns must lie in a straight line. This line is called the *hydraulic gradient*, or virtual slope of the pipe. Evidently the vertical ordinate between any point in the pipe and the hydraulic gradient measures the kinetic pressure head at the point in question.

**Slope of Hydraulic Gradient.**—When a pipe is not straight, successive points on the hydraulic gradient may be determined by computing the loss of head between these points from the relation

$$h = f \left( \frac{l}{d} \right) \frac{v^2}{2g},$$

taking as successive values of  $l$  the length of pipe between the points considered.

In water mains the vertical curvature of the pipe line is generally small, and its effect on the hydraulic gradient is usually

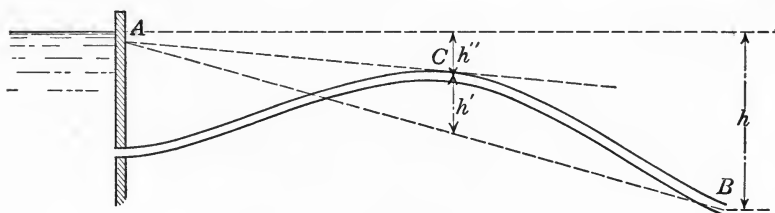

FIG. 82.

neglected. When, however, a valve or other obstruction occurs in a pipe there is a sudden drop in the hydraulic gradient at the obstruction, due to the loss of head caused by it.

It should be noted that the upper end of the hydraulic gradient lies below the water level in the reservoir a distance equal to the head lost at entrance plus the velocity head. The slope of the hydraulic gradient is usually defined, however, as

$$\text{Slope of hydraulic gradient} = \frac{\text{static head}}{\text{length of pipe}},$$

which is equivalent to neglecting the velocity head and head lost at entrance, thereby making the assumed hydraulic gradient slightly steeper than it actually is.

**Peaks above Hydraulic Gradient.**—When part of the pipe line rises above the hydraulic gradient (Fig. 82), the pressure in this portion must be less than atmospheric since the pressure head  $h'$  becomes negative. If the pipe is air-tight and filled be-

fore the flow is started this will not affect the discharge. If the pipe is not air-tight, air will collect at the summit above the hydraulic gradient, changing the slope of the latter from  $AB$  to  $AC$  as indicated in Fig. 82, thereby reducing the head to  $h''$  with a corresponding diminution of the flow. Before laying a long pipe line the hydraulic gradient should therefore be plotted on the profile to make sure there are no summits projecting above the gradient. In case such summits are unavoidable, provision should be made for exhausting the air which may collect at these points, so as to maintain full flow.

### 19. HYDRAULIC RADIUS

**Definition.**—That part of the boundary of the cross section of a channel or pipe which is in contact with the water in it is called the *wetted perimeter*, and the area of the cross section of the stream divided by the wetted perimeter is called the *hydraulic radius*, or hydraulic mean depth. In what follows the hydraulic radius will be denoted by  $r$ , defined as

$$\text{Hydraulic radius, } r = \frac{\text{Area of flow}}{\text{Wetted perimeter}}$$

Some writers apply the term hydraulic radius only to circular pipes, and use the term hydraulic mean depth for flow in channels.

For a channel of rectangular cross section having a breadth  $b$  and depth of water  $h$ , the hydraulic radius is

$$r = \frac{bh}{b + 2h}$$

In a circular pipe of diameter  $d$ , running full, the hydraulic radius is

$$r = \frac{\frac{\pi d^2}{4}}{\pi d} = \frac{d}{4}$$

For the same pipe running half full,

$$r = \frac{\frac{\pi d^2}{8}}{\frac{\pi d}{2}} = \frac{d}{4}$$

and is therefore the same as when the pipe is full.

Other examples of the hydraulic radius are shown in Figs. 98-104.

**Chezy's Formula.**—The formula proposed by Chezy for the velocity of flow in a long pipe is

$$v = C \sqrt{rs}, \quad (56)$$

where  $s$  denotes the slope of the hydraulic gradient, defined in the preceding article;  $r$  is the hydraulic radius, defined above; and  $C$  is an empirical constant which depends on the velocity of flow, diameter of pipe, and roughness of its lining.

For a circular pipe flowing full Chezy's formula is identical with the formula for friction loss in a pipe, given by Eq. (48), Art. 17, namely,

$$h = f \left( \frac{l}{d} \right) \frac{v^2}{2g}.$$

To show this identity, substitute in Chezy's formula the values

$$r = \frac{d}{4} \text{ and } s = \frac{h}{l}.$$

Then it becomes

$$v = C \sqrt{\frac{dh}{4l}},$$

whence, by squaring and solving for  $h$ , it takes the form

$$h = \frac{4}{C^2} \left( \frac{l}{d} \right) v^2 = \frac{8g}{C^2} \left( \frac{l}{d} \right) \frac{v^2}{2g}.$$

Consequently, if the constant term  $\frac{8g}{C^2}$  is denoted by  $f$ , that is,

$$f = \frac{8g}{C^2}, \text{ or } C = \sqrt{\frac{8g}{f}},$$

Chezy's formula assumes the standard form,

$$h = f \left( \frac{l}{d} \right) \frac{v^2}{2g}.$$

The most important application of Chezy's formula is to flow in open channels, as explained in Art. 24.

It has been found by experiment that the coefficient  $C$  in Chezy's formula is not strictly constant for any particular channel and dependent only on the roughness of the channel lining, but that it also varies with the slope and the hydraulic radius.

This variation may be taken into account by writing the formula in the exponential form

$$v = Cr^{m_3}n$$

where the exponents  $m$  and  $n$  are also empirical constants. Experimental data for this formula are not yet sufficient, however, to make its use practical.

## 20. DIVIDED FLOW

**Compound Pipes.**—In water works calculations the problem often arises of determining the flow through a compound system of branching mains.

To illustrate the method of finding the discharge through the various branches, consider first the simple case of a main tapped

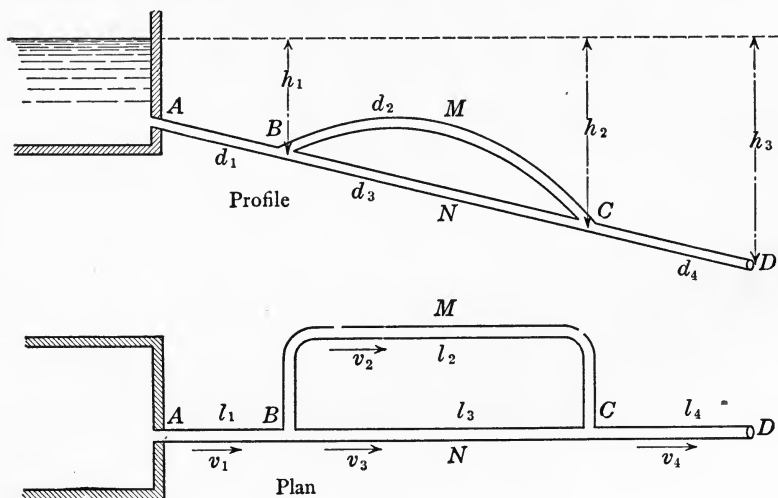

FIG. 83.

by a branch pipe which later returns to the main, as indicated in Fig. 83. The solution in this case is based on the fundamental relation deduced in Art. 17, namely,

$$h = \frac{v^2}{2g} + h_l$$

where  $h$  denotes the static head, and  $h_l$  the head lost in friction. Using the notation indicated on the figure and considering the

two branches separately, we obtain the following equations:—  
For line *ABMCD*,

$$h_3 = \frac{v_4^2}{2g} + f \left( \frac{l_1}{d_1} \right) \frac{v_1^2}{2g} + f \left( \frac{l_2}{d_2} \right) \frac{v_2^2}{2g} + f \left( \frac{l_4}{d_4} \right) \frac{v_4^2}{2g}. \quad (57)$$

For line *ABNCD*,

$$h_3 = \frac{v_4^2}{2g} + f \left( \frac{l_1}{d_1} \right) \frac{v_1^2}{2g} + f \left( \frac{l_3}{d_3} \right) \frac{v_3^2}{2g} + f \left( \frac{l_4}{d_4} \right) \frac{v_4^2}{2g}. \quad (58)$$

By subtraction of these two equations we have

$$f \left( \frac{l_2}{d_2} \right) \frac{v_2^2}{2g} = f \left( \frac{l_3}{d_3} \right) \frac{v_3^2}{2g}, \quad (59)$$

which shows that the frictional head lost in the branch *BMC* is equal to that lost in *BNC*.

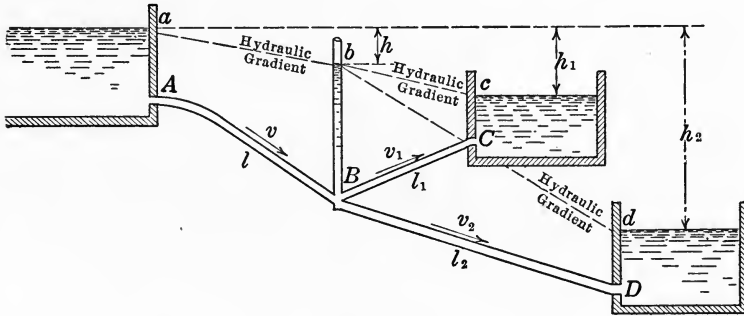

FIG. 84.

Since the total discharge through the branches is the same as that through the main before dividing and after uniting, we also have the two relations

$$a_1 v_1 = a_2 v_2 + a_3 v_3 = a_4 v_4. \quad (60)$$

By assuming an average value for the frictional coefficient  $f$ , the four Eq. (57), (58), (59) and (60) may then be solved for the four unknowns  $v_1$ ,  $v_2$ ,  $v_3$ ,  $v_4$ . Having found approximate values of the velocities, corresponding values of  $f$  may be substituted in these equations and the solution repeated, thus giving more accurate values of the velocities.

Having found the velocities, the discharge through the various pipes may be obtained from the relations

$$Q_1 = Q_4 = a_1 v_1 = a_4 v_4; \quad Q_2 = a_2 v_2; \quad Q_3 = a_3 v_3.$$

The solution for more complicated cases is identical with the above, except that more equations are involved.

**Branching Pipes.**—Another simple case of divided flow which is often met is that in which a pipe  $AB$  of diameter  $d$  divides at some point  $B$  into two other pipes,  $BC$  and  $BD$ , of diameters  $d_1$  and  $d_2$  respectively, which discharge into reservoirs or into the air (Fig. 84). If any outlet, as  $C$ , is higher than the junction  $B$ , then in order for flow to take place in the direction  $BC$ , the hydraulic gradient must slope in this direction; that is to say there must be a drop in pressure between the junction  $B$  and the level of the outlet reservoir  $C$ , or, in the notation of the figure, the condition for flow in the direction  $BC$  is  $h_1 > h$ .

Assuming this to be the case, the solution is obtained from the same fundamental relation as above, namely,

$$h = \frac{v^2}{2g} + h_1.$$

Using the notation indicated on the figure for length, diameter and velocity in the various pipes and considering one line at a time, we thus obtain the following equations:

$$\text{For line } ABC, \quad h_1 = \frac{v_1^2}{2g} + f\left(\frac{l}{d}\right)\frac{v^2}{2g} + f\left(\frac{l_1}{d_1}\right)\frac{v_1^2}{2g}; \quad (61)$$

$$\text{For line } ABD, \quad h_2 = \frac{v_2^2}{2g} + f\left(\frac{l}{d}\right)\frac{v^2}{2g} + f\left(\frac{l_2}{d_2}\right)\frac{v_2^2}{2g}. \quad (62)$$

Also, from the condition that the discharge through the main pipe must equal the sum of the discharges through the branches, denoting the cross-sectional areas by  $a$ ,  $a_1$ ,  $a_2$  respectively, we have

$$av = a_1v_1 + a_2v_2. \quad (49)$$

By assuming an average value for the frictional coefficient  $f$ , these three equations may then be solved for the three unknowns  $v$ ,  $v_1$  and  $v_2$ . Having thus found approximate values of the velocities, the exact value of  $f$  corresponding to each velocity may be substituted in the above equations and the solution repeated, giving more accurate values of the velocities. Having found the velocities, the discharge from each pipe is obtained at once from the relations

$$Q = av; \quad Q_1 = a_1v_1; \quad Q_2 = a_2v_2.$$

The method of solution is the same for any number of branches, there being as many equations in any given case as there are unknown velocities to be determined.

Other simple cases of divided flow are illustrated in the numerical examples at the end of the chapter.

## 21. FIRE STREAMS

**Freeman's Experiments.**—Extensive and accurate experiments on discharge through fire hose and nozzles were made by John R. Freeman at Lawrence, Mass., in 1888 and 1890.<sup>1</sup>

From these experiments it was found that the smooth cone nozzle with simple play pipe is the most efficient for fire streams, the coefficient of discharge being nearly constant for the various types tried and having an average value of 0.974 for smooth cone nozzles and 0.74 for square ring nozzles.

The friction losses for fire hose were found to depend chiefly on the nature of the interior surface of the hose, the loss in unlined linen hose being about 2-1/2 times as great as in smooth rubber hose of the same diameter. The friction loss was also found to vary approximately as the square of the velocity of flow.

For fire hose laid in ordinary smooth curves but not cramped or kinked, the friction loss was found to be about 6 per cent. greater than in perfectly straight hose.

**Formulas for Discharge.**—The following formulas for discharge were deduced by Freeman from these experiments.

Notation:

$Q$  = discharge in cubic feet per second,

$G$  = discharge in gallons per minute =  $448.83Q$ ,

$h$  = piezometer reading at base of nozzle in feet of water,

$p$  = pressure at base of nozzle in pounds per square inch =  $0.434h$ ,

$K$  = coefficient of discharge,

$C_c$  = coefficient of contraction,

$d$  = diameter of nozzle orifice in inches,

$D$  = diameter of channel, where pressure is measured, in inches,

$H$  = total hydrostatic head in feet =  $\frac{h}{1 - C^2 \left(\frac{d}{D}\right)^4}$ .

<sup>1</sup> Trans. Am. Soc. C. E. Vol. 21, pp. 303-482; Vol. 24, pp. 492-527.

Then

$$\left. \begin{aligned}
 Q &= 0.04374Kd^2 \left[ \frac{h}{1 - K^2 \left( \frac{d}{D} \right)^4} \right]^{1/2}, \\
 &= 0.04374Kd^2 \sqrt{H}, \\
 &= 0.06645Kd^2 \left[ \frac{p}{1 - K^2 \left( \frac{d}{D} \right)^4} \right]^{1/2},
 \end{aligned} \right\} \quad (63)$$

and

$$\left. \begin{aligned}
 G &= 19.635Kd^2 \left[ \frac{h}{1 - K^2 \left( \frac{d}{D} \right)^4} \right]^{1/2}, \\
 &= 19.635Kd^2 \sqrt{H}, \\
 &= 29.83 Kd^2 \left[ \frac{p}{1 - K^2 \left( \frac{d}{D} \right)^4} \right]^{1/2}.
 \end{aligned} \right\} \quad (64)$$

**Height of Effective Fire Stream.**—It was also found that the height,  $y$ , of extreme drops in still air from nozzles ranging in size from 3/4 in. to 1-3/8 in. in diameter was given by the formula

$$y = H - 0.00135 \frac{H^2}{d \sqrt{C_c}} \quad (65)$$

The height of a first class fire stream will then be a certain fraction of  $y$  as indicated in the following table:

When $y =$	50 ft.	75 ft.	100 ft.	125 ft.	150 ft.
Height of first class fire stream =	0.82 $y$	0.79 $y$	0.73 $y$	0.67 $y$	0.63 $y$

Table 11 is abridged from a similar table computed by Freeman from these and other formulas, not here given, and will be found convenient to use in solving fire-stream problems.

## 22. EXPERIMENTS ON THE FLOW OF WATER

**Verification of Theory by Experiment.**—The subject of hydraulics as presented in an elementary text book is necessarily limited to simple demonstrations of the fundamental principles. It should not be inferred from this that the subject is largely experimental and not susceptible of mathematical analysis. As a matter of fact, hydrodynamics is one of the most difficult branches of applied mathematics, and its development has absorbed the



best efforts of such eminent mathematical physicists as Poinso, Kirchhoff, Helmholtz, Maxwell, Kelvin, Stokes and Lamb. Naturally the results are too technical to be generally appreciated, but afford a rich field for study to those with sufficient mathematical preparation.



Sudden contraction.

Sudden enlargement.

FIG. 85.

Some of the results concerning the flow of liquids derived by mathematical analysis have been verified experimentally by the English engineers, Professor H. S. Hele-Shaw and Professor Osborne Reynolds. The chief importance of these experiments is that they serve to visualize difficult theoretical results.

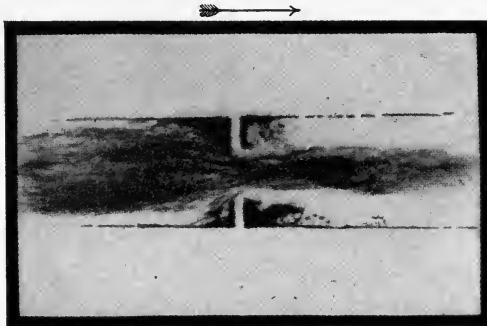

Contraction.

Enlargement.

FIG. 86.

**Method of Conducting Experiments.**—In Art. 8 a stream line was defined as the path followed by a particle of liquid in its motion. A set of stream lines distributed through a flowing liquid therefore completely determines the nature of the flow. To make such stream lines visible, so as to make it possible to actually trace the motion of the particles of a clear fluid, both experimenters named above allowed small bubbles of air to enter

a flowing stream. These bubbles do not make the motion directly visible to the eye, but by making the pipe or channel of glass and projecting a portion of it on a screen by means of a lantern, its image on the screen as viewed in this transmitted light clearly shows certain characteristic features.

**Effect of Sudden Contraction or Enlargement.**—Figs. 85 and 86, reproduced by permission of Professor Hele-Shaw, show the effect of a sudden contraction or enlargement of the channel section. It is noteworthy that the disturbance or eddying is much

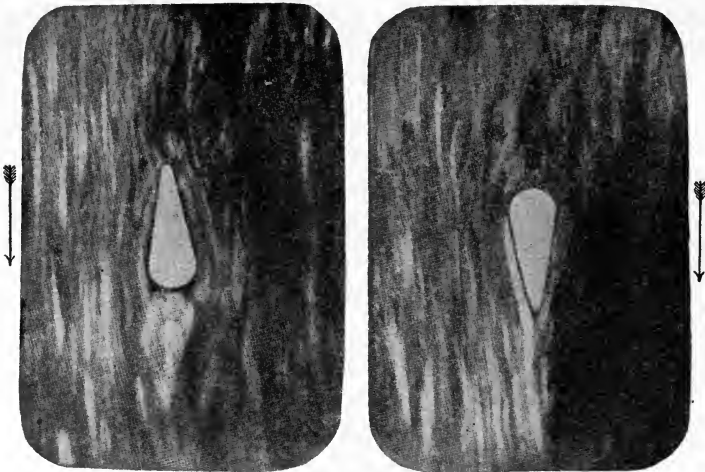

FIG. 87.

greater for a sudden enlargement than for a sudden contraction. This is due to the inertia of the fluid which prevents it from immediately filling the channel after passing through the orifice. This also confirms what has already been observed in practice, namely, that the loss of energy due to a sudden enlargement in a pipe is much greater than that due to a corresponding contraction.

**Disturbance Produced by Obstacle in Current.**—If the channel is of considerable extent and a small obstacle is placed in it, the stream lines curve around the obstacle, leaving a small space behind it, as shown in Fig. 87. If the object is a square block or flat plate this effect is greatly magnified, as shown in Fig. 88. The water is prevented from closing at once behind the obstacle by reason of its inertia. This indicates why the design of the

stern of a ship is so much more important than that of the bow, since if there are eddys in the wake of a ship, the pressure of the water at the stern is decreased, thereby increasing by just this much the effective resistance to motion at the bow.

**Stream-line Motion in Thin Film.**—In these experiments it was also observed that there was always a clear film of liquid, or border line, on the sides of the channel and around the obstacle. This observed fact was accounted for on the ground that by reason of the friction between a viscous liquid and the sides of the

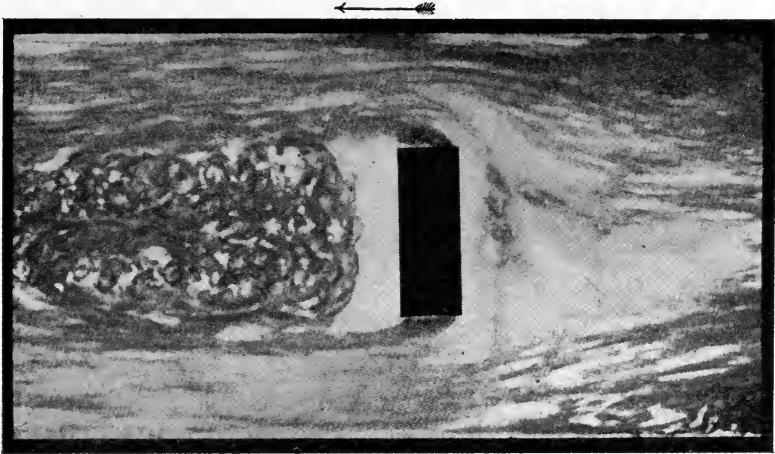

FIG. 88.

channel or obstacle, the thin film of liquid affected was not moving with turbulent motion but with true stream line motion, as in an ideal fluid. To isolate this film so as to observe its motion, water was allowed to flow between two plates of glass in a sheet so thin that its depth corresponded to the thickness of the border line previously observed. When this was done it immediately became apparent that the flow was no longer turbulent but a steady stream-line motion. The flow of a viscous fluid like glycerine in a thin film thus not only eliminates turbulent flow, but also to a certain extent the inertia effects, thereby resulting in true stream-line flow.

**Cylinder and Flat Plate.**—To make the stream lines visible, colored liquid was injected through a series of small openings, the result being to produce an equal number of colored bands or stream lines in the liquid. Fig. 89 shows these stream-lines for

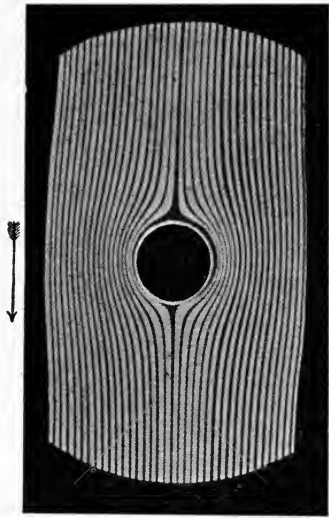

FIG. 89.

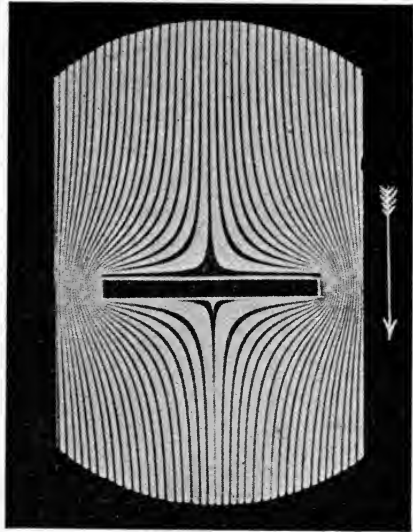
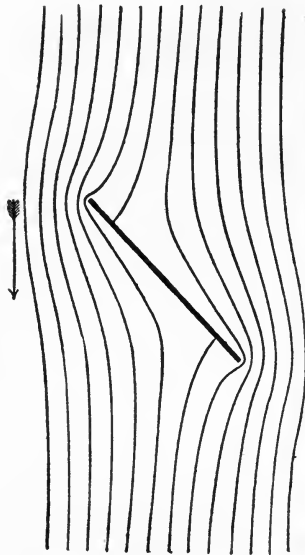

FIG. 90.



Theory



Experiment

FIG. 91.

a cylinder, and Fig. 90 for a flat plate placed directly across the current, while Fig. 91 shows a comparison of theory and experiment for a flat plate inclined to the current.

**Velocity and Pressure.**—The variation in thickness of the bands is due to the difference in velocity in various parts of the channel, the bands of course being thinnest where the velocity is greatest. Since a decrease in velocity is accompanied by a certain increase in pressure, the wide bands before and behind the obstacle indicate a region of higher pressure. This accounts for the standing bow and stern waves of a ship, whereas the narrowing of the bands at the sides indicates an increase of velocity and reduction of pressure, and accounts for the depression of the water level at this part of a ship.

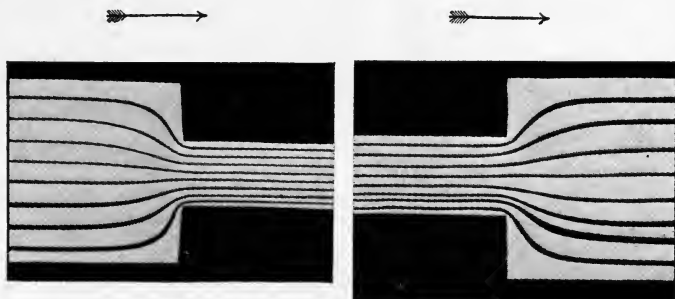

FIG. 92.

In the case of a sudden contraction or enlargement of the channel section, the true stream-line nature of the flow was clearly apparent, as shown in Fig. 92, the stream lines following closely the form derived by mathematical analysis for a perfect fluid.

### 23. MODERN SIPHONS

**Principle of Operation.**—In its simplest form, a siphon is merely an inverted U-shaped tube, with one leg longer than the other, which is used for emptying tanks from the top when no outlet is available below the surface. In use, the tube is filled with liquid and the ends corked, or otherwise closed. The short end of the tube is then placed in the reservoir to be lowered, so that the level of the end outside is lower than the surface of the reservoir (Fig. 93). When the ends of the tube are opened, the liquid in the reservoir begins to flow through the tube with a head,

$h$ , equal to the difference in level between the surface of the reservoir and the lower, or outer, end of the tube. If the inner end of the siphon is placed close to the bottom of the reservoir

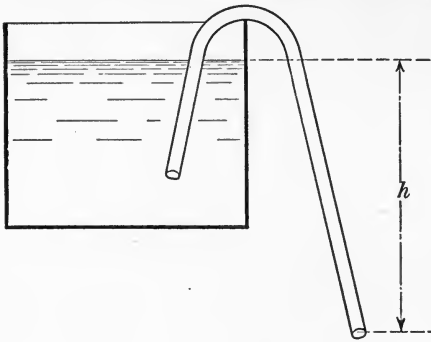

FIG. 93.

it can be practically emptied in this manner. For emptying small tanks a siphon can conveniently be made of a piece of ordinary tubing or hose.

**Siphon Spillway.**—Recent commercial applications of the siphon on a large scale are the siphon spillways and siphon lock on the New York State barge canal. At three localities on the Champlain division of the Barge canal the siphon principle is being used for the first time to create a spillway of any considerable size. At the place shown in Fig. 94, it was necessary

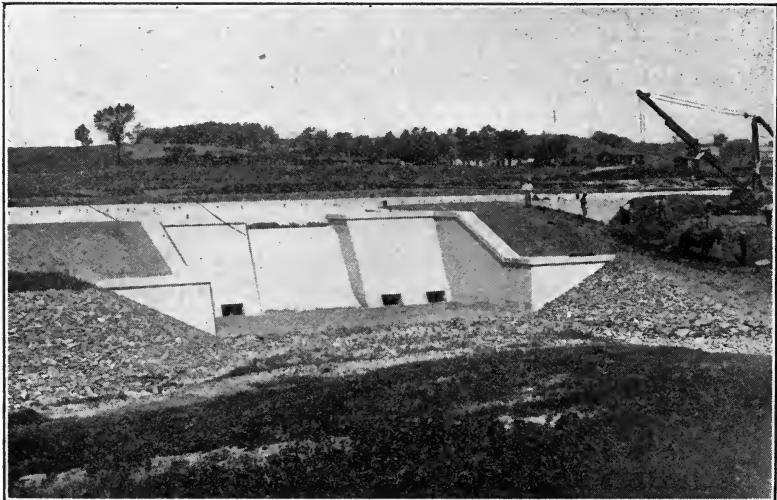

FIG. 94.—Siphon Spillway, Champlain division, New York State barge canal.

to provide for a maximum outflow of about 700 cu. ft. per second and to limit the fluctuation of water surface to about 1 ft. The ordinary waste weir of a capacity sufficient to take care of this

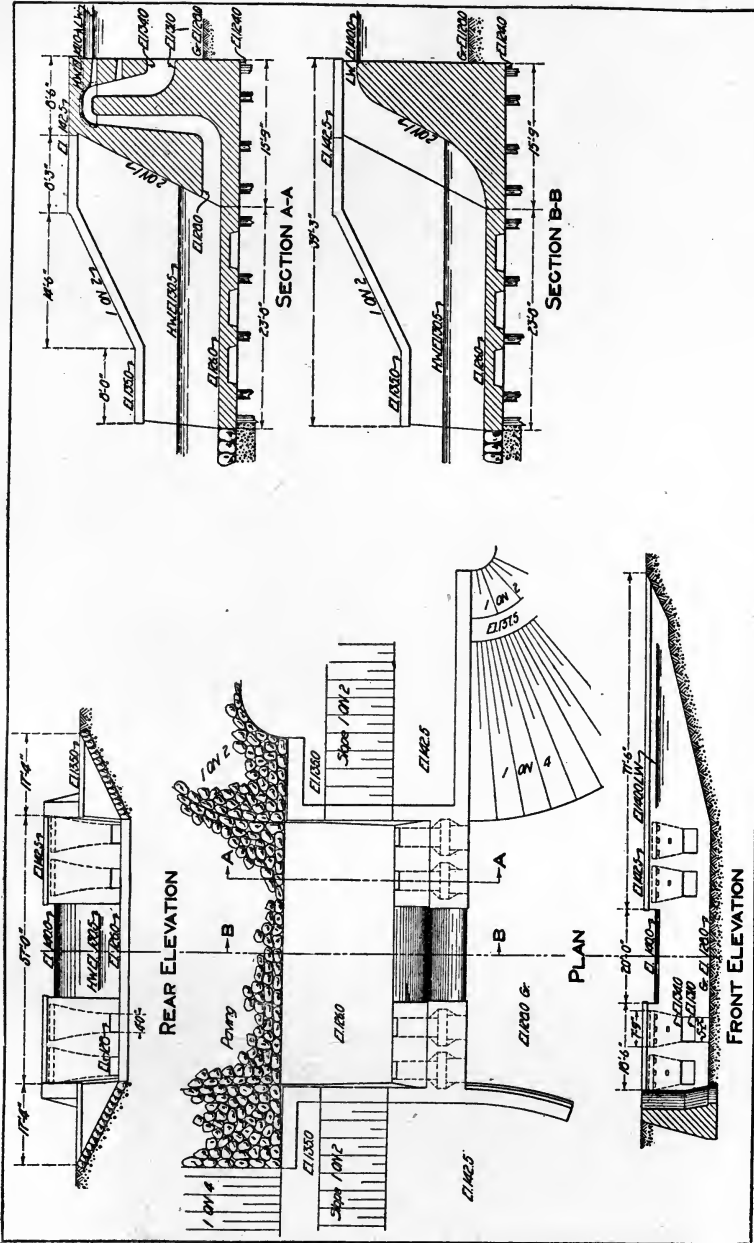

Fig. 95.—Detail of siphon spillway.

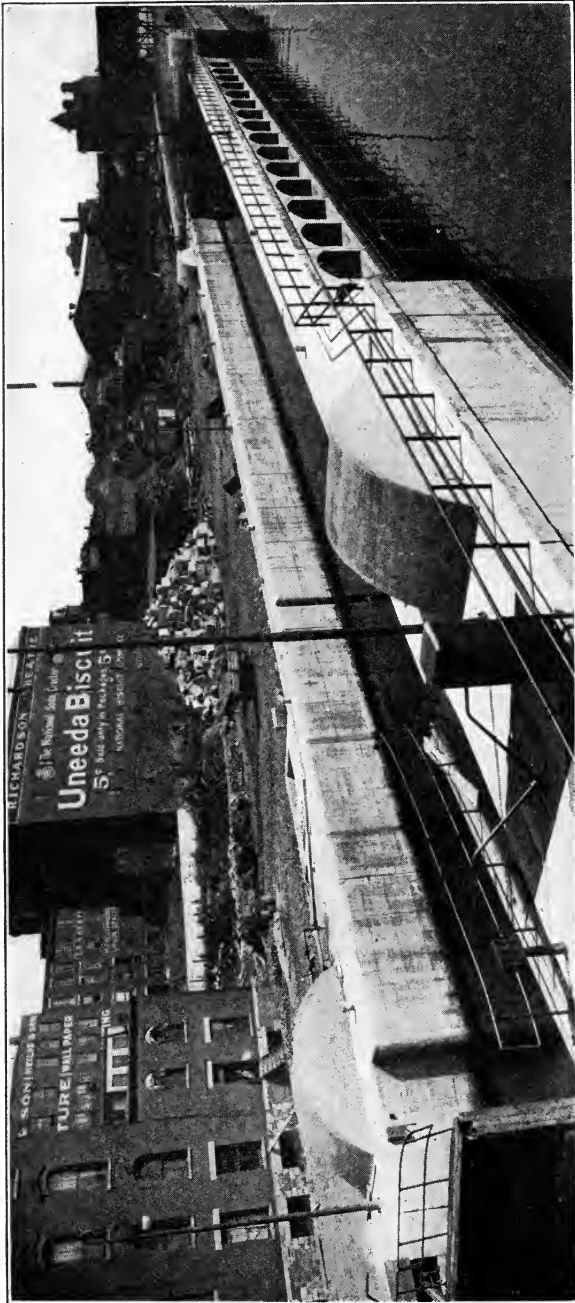

FIG. 96.—Siphon lock at Oswego, New York State barge canal.



flow, with a depth of only 1 ft. of water on the crest, would require a spillway 200 ft. long. The siphon spillway measures

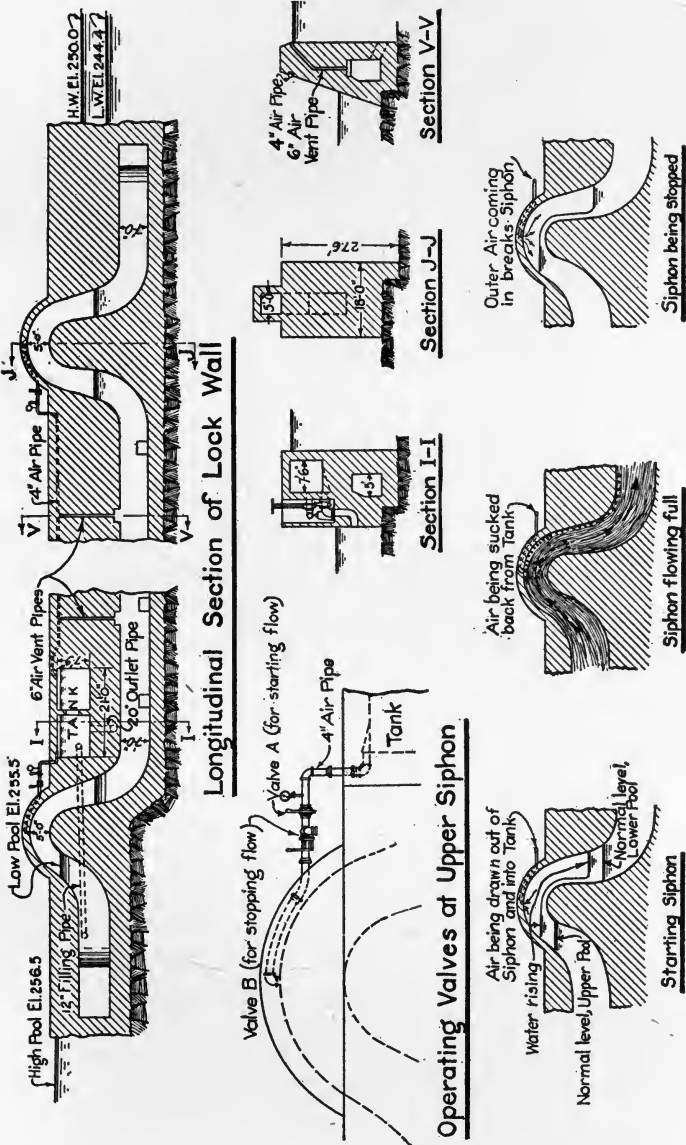

FIG. 97.—Detail of siphon lock.

only 57 ft. between abutments and accomplishes the same results. This particular structure consists of four siphons, each having a

cross-sectional area of  $7\text{-}\frac{3}{4}$  sq. ft. and working under a  $10\text{-}\frac{1}{2}$ -ft. head. There is also a 20-ft. drift gap to carry off floating débris. The main features of construction are shown in Fig. 95. The siphon spillway was designed and patented by Mr. George F. Stickney, one of the Barge canal engineers.

**Siphon Lock.**—The siphon lock on the New York State Barge Canal is located in the city of Oswego, and is the only lock of this type in this country and the largest ever built on this principle. It consists of two siphons, as shown in Fig. 96, the crown of each being connected by a 4-in. pipe to an air tank in which a partial vacuum is maintained. To start the flow, the air valve is opened, the vacuum in the tank drawing the air from the siphon and thereby starting the flow. When the siphon is discharging fully, its draft is such that the air is sucked out of the tank, thus restoring the partial vacuum. To stop the flow, outer air is admitted to the crest of the siphon by another valve, thereby breaking the flow, as indicated in Fig. 97. The operating power is thus self renewing, and, except for air leakage, lockages can be conducted by merely manipulating the 4-in. air valves. However, to avoid the necessity of refilling the tank when traffic is infrequent, it is customary to close the 20-in. outlet valve, thus holding the water in the tank. Using both siphons, the lock chamber can be filled in  $4\text{-}\frac{1}{2}$  to 5 min., and emptied in  $5\text{-}\frac{1}{2}$  to 6 min.

## 24. FLOW IN OPEN CHANNELS

**Open and Closed Conduits.**—Conduits for conveying water are usually classified as open and closed. By a closed conduit is meant one flowing full under pressure, as in the case of ordinary pipe flow discussed in Art. 15. Water mains, penstocks, draft tubes and fire hose are all examples of closed conduits.

Open channels, or conduits, are those in which the upper surface of the liquid is exposed to atmospheric pressure only, the pressure at any point in the stream depending merely on the depth of this point below the free surface. Rivers, canals, flumes, aqueducts and sewers are ordinarily open channels. A river or canal, however, may temporarily become a closed channel when covered with ice, and an aqueduct or sewer may also become a closed channel if flowing full under pressure.

**Steady Uniform Flow.**—The fundamental laws applying to flow in open and closed channels are probably identical, and in

the case of steady, uniform flow the same formulas apply to both. For steady flow in an open channel the quantity of water passing any transverse section of the stream is constant, and for uniform flow the mean velocity is also constant. Under these conditions the cross-sectional area of the stream is constant throughout its length, and the hydraulic gradient is the slope of the surface of the stream. The formula for velocity of flow is then the one given in Art. 19 under the name of Chezy's formula, namely

$$v = C \sqrt{rs}. \tag{66}$$

**Kutter's Formula.**—Numerous experiments have been made to determine the value of the coefficient  $C$  for open channels. In 1869, E. Ganguillet and W. R. Kutter, two Swiss engineers, made a careful determination of this constant, the result being expressed in the following form:

$$v = \left[ \frac{41.65 + \frac{0.00281}{s} + \frac{1.811}{n}}{1 + \left[ 41.65 + \frac{0.00281}{s} \right] \frac{n}{\sqrt{r}}} \right] \sqrt{rs} \tag{67}$$

in which

$s$  = hydraulic gradient, or slope of channel,

$r$  = hydraulic radius =  $\frac{\text{area of flow}}{\text{wetted perimeter}}$ ,

$n$  = coefficient of roughness.

The coefficient of roughness,  $n$ , depends on the nature of the channel lining. Approximate values of  $n$  for various surfaces are given in the following table:

Nature of Channel Lining	$n$
Planed timber carefully joined, glazed or enameled surfaces.....	0.009
Smooth clean cement.....	0.010
Cement mortar, one-third sand.....	0.011
Unplaned timber or good new brickwork.....	0.012
Smooth stonework, vitrified sewer pipe and ordinary brickwork...	0.013
Rough ashlar and good rubble masonry.....	0.017
Firm gravel.....	0.020
Ordinary earth.....	0.025
Earth with stones, weeds, etc.....	0.030
Earth or gravel in bad condition.....	0.035

**Limitations to Kutter's Formula.**—Kutter's formula, Eq. (67), is widely used and is reliable when applied to steady, uniform

flow under normal conditions. From a study of the data on which this formula is based, its use has been found to be subject to the following limitations:

It is not reliable for hydraulic radii greater than 10 ft., or velocities greater than 10 ft. per sec., or slopes flatter than 1 in 10,000. Within these limits a variation of about 5 per cent. may be expected between actual results and those computed from the formula.

Table 15 gives numerical values of the coefficient  $C$  calculated from Formula (67).

**Bazin's Formula.**—In 1897, H. Bazin also made a careful determination of the coefficient  $C$  from all the experimental data then available, as the result of which he proposed the following formula:

$$v = \left[ \frac{87}{0.552 + \frac{m}{\sqrt{r}}} \right] \sqrt{rs}, \quad (68)$$

where  $r$  = hydraulic radius,

$m$  = coefficient of roughness.

Bazin's formula has the advantage of being simpler than Kutter's, and is independent of the slope  $s$ . Values of the coefficient of roughness,  $m$ , for use with this formula are given in the following table:

Nature of Channel Lining	$m$
Planned timber or smooth cement.....	0.06
Unplanned timber, well-laid brick or concrete.....	0.16
Ashlar, good rubble masonry or poor brickwork.....	0.46
Earth in good condition.....	0.85
Earth in ordinary condition.....	1.30
Earth in bad condition.....	1.75

Table 14 gives numerical values of the coefficient  $C$  calculated from formula (68).

**Kutter's Simplified Formula.**—A simplified form of Kutter's formula which is also widely used is the following:

$$v = \left[ \frac{100 \sqrt{r}}{b + \sqrt{r}} \right] \sqrt{rs},$$

where  $b$  is a coefficient of roughness which varies from 0.12 to 2.44. For ordinary sewer work the value of this coefficient may be assumed as  $b = 0.35$ .

## 25. CHANNEL CROSS SECTION

**Condition for Maximum Discharge.**—From the Chezy formula for flow in open channels, namely,

$$Q = Av = AC\sqrt{rs},$$

it is evident that for a given stream section  $A$  and given slope  $s$ , the maximum discharge will be obtained for that form of cross section for which the hydraulic radius  $r$  is a maximum. Since

$$r = \frac{\text{area of flow}}{\text{wetted perimeter}},$$

this condition means that for constant area the radius  $r$ , and therefore the discharge, is a maximum when the wetted perimeter is a minimum. The reason for this is simply that by making the area of contact between channel lining and water as small as possible, the frictional resistance is reduced to a minimum, thus giving the maximum discharge.

**Maximum Hydraulic Efficiency.**—In consequence of this, it follows that the maximum hydraulic efficiency is obtained from a semicircular cross section, since for a given area its wetted perimeter is less than for any other form (Fig. 98). For rectangular sections the half square has the least perimeter for a given area, and consequently is most efficient (Fig. 99). Similarly, for a trapezoidal section the half hexagon is the most efficient (Fig. 100). In each case the hydraulic radius is half the water depth, as proved below.

In the case of unlined open channels it is necessary to use the trapezoidal section, the slope of the sides being determined by the nature of the soil forming the sides. This angle having been determined, the best proportions for the section are obtained by making the sides and bottom of the channel tangent to a semi-circle drawn with center in the water surface (Fig. 101).

**Regular Circumscribed Polygon.**—Any section which forms half of a regular polygon of an even number of sides, and has each of its faces tangent to a semi-circle having its center in the water surface, will have its hydraulic radius equal to half the radius of this inscribed circle (Figs. 98–103). To prove this, draw radii from the center of the inscribed circle to each angle of the polygon. Then since the area of each of the triangles so formed is equal to

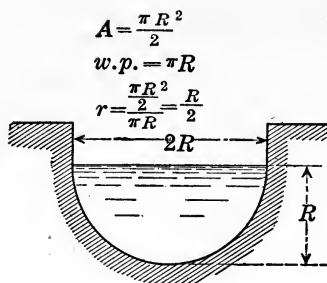

Semicircle

FIG. 98.

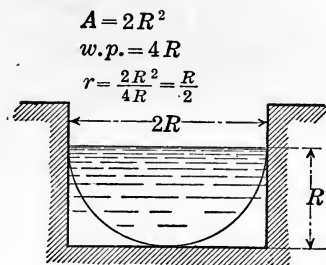

Half Square

FIG. 99.

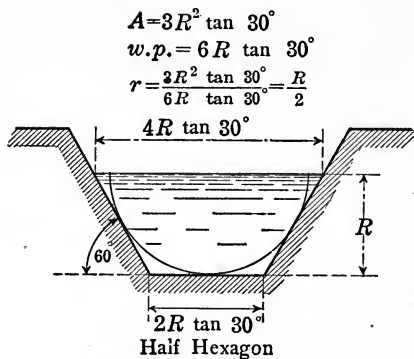

Half Hexagon

FIG. 100.

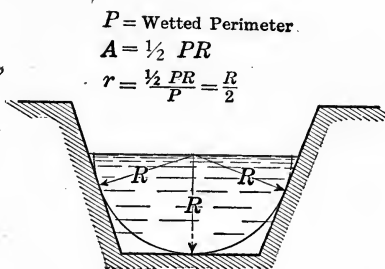

Trapezoid

FIG. 101.

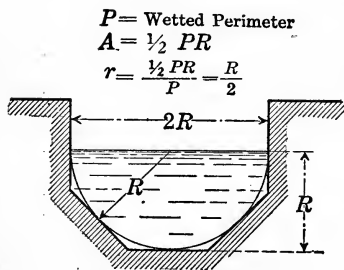

Half Octagon

FIG. 102.

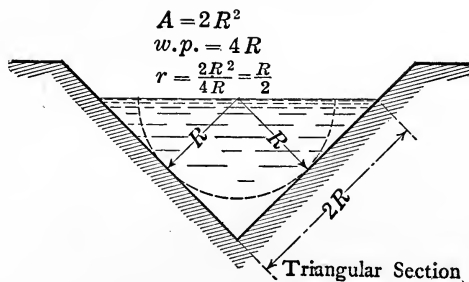

Triangular Section

FIG. 103.

	Angle $\phi$	Water depth $h$	Water section $A$	Wetted perimeter $p$	Hydraulic Radius $r = \frac{A}{p}$	Velocity $v$	Discharge $Q$	Condition of flow
Circular Section	180°	$h = 0.5D$	$A = 1.571R^2$	$p = 3.142R$	$r = 0.5R$	$v = 0.707C\sqrt{R_s}$	$Q = 1.111C\sqrt{R_s^3}$	Half full
	257.5°	0.809D	$2.735R^2$	4.493R	0.609R	$0.780C\sqrt{R_s}$	$2.133C\sqrt{R_s^3}$	Maximum velocity
	308°	0.949D	$3.082R^2$	5.379R	0.573R	$0.757C\sqrt{R_s}$	$2.333C\sqrt{R_s^3}$	Maximum discharge
	360°	D	$3.142R^2$	6.283R	0.500R	$0.707C\sqrt{R_s}$	$2.221C\sqrt{R_s^3}$	Full
Oval Section	180°	$h = 0.667H$	$A = 3.023R^2$	$p = 4.788R$	$r = 0.631R$	$v = 0.795C\sqrt{R_s}$	$Q = 2.400C\sqrt{R_s^3}$	Half full
	248.5°	0.854H	$4.086R^2$	5.984R	0.683R	$0.826C\sqrt{R_s}$	$3.377C\sqrt{R_s^3}$	Maximum velocity
	297.5°	0.952H	$4.493R^2$	6.841R	0.657R	$0.810C\sqrt{R_s}$	$3.641C\sqrt{R_s^3}$	Maximum discharge
	360°	H	$4.594R^2$	7.930R	0.579R	$0.761C\sqrt{R_s}$	$3.496C\sqrt{R_s^3}$	Full

one-half its base times its altitude, and since the altitude in each case is a radius of the inscribed circle, the total area is

$$\text{Area} = \frac{R}{2} \times \text{perimeter.}$$

Consequently the hydraulic radius  $r$  is

$$r = \frac{\text{area of flow}}{\text{wetted perimeter}} = \frac{\frac{R}{2} \times \text{perimeter}}{\text{perimeter}} = \frac{R}{2}.$$

**Properties of Circular and Oval Sections.**—For circular and oval cross sections, the maximum velocity and maximum dis-

$$A = \frac{D^2}{8} (\phi - \sin \phi) \quad \text{Angle } \phi \text{ in Radians}$$

$$w.p. = \frac{D}{2} \times \phi \quad h = \frac{D}{2} (1 - \cos \frac{\phi}{2})$$

$$r = \frac{A}{w.p.} = \frac{D}{4} (1 - \frac{\sin \phi}{\phi})$$

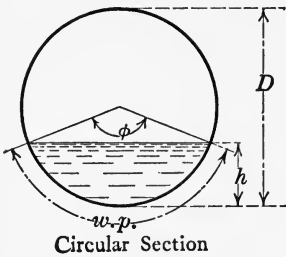

FIG. 104.

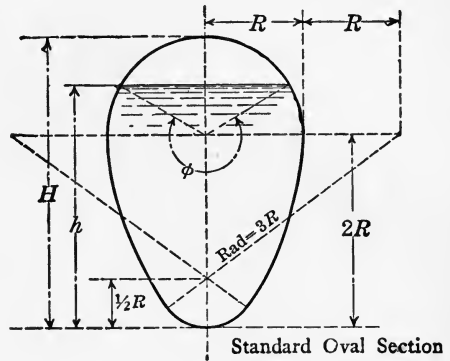

FIG. 105.

charge are obtained when the conduit is flowing partly full, as apparent from the table on page 105, which is a collection of the most important data for circular and oval sections,<sup>1</sup> as shown in Figs. 104 and 105.

Theoretically, the maximum discharge for a circular pipe occurs when the pipe is filled to a depth of 0.949  $D$ , but if it is attempted to maintain flow at this depth, the waves formed in the pipe strike against the top, filling it at periodic intervals and thus producing impact losses. To obtain the maximum discharge without danger of impact, the actual depth of flow should not exceed  $5/6 D$ .

## 26. FLOW IN NATURAL CHANNELS

**Stream Gaging.**—In the case of a stream flowing in a natural channel the conditions determining the flow are so variable that

<sup>1</sup> Weyrauch, *Hydraulisches Rechnen*, S. 51.



no formula for computing the discharge has been devised that can claim to give results even approximately correct. To obtain accurate results, direct measurements of cross sections and velocities must be made in the field.

The two methods of direct measurement in general use are as follows: Either

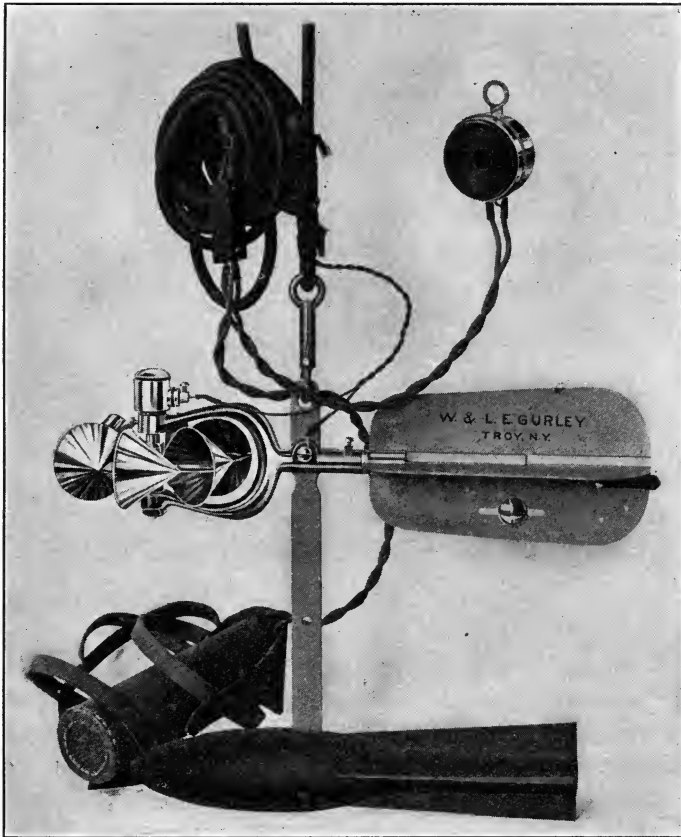

FIG. 106.—Electric current meter.

1. The construction of a weir across the stream, and the calculation of the discharge from a weir formula; or, if this is not feasible,
2. The measurement of cross sections of the stream by means of soundings taken at intervals, and the determination of average velocities by a current meter or floats.

The first of these methods is explained in Art. 11.

**Current Meter Measurements.**—The current meter, one type of which is shown in Fig. 106, consists essentially of a bucket wheel with a heavy weight suspended from it to keep its axis horizontal, and a vane to keep it directed against the current, together with some form of counter to indicate the speed at which the wheel revolves. The meter is first rated by towing it through still water at various known velocities and tabulating the corresponding wheel speeds. From these results a table, or chart, is constructed giving the velocity of the current corresponding to any given speed of the wheel as indicated by the counter. This method of calibration, however, is more or less inaccurate, as apparent from Du Buat's paradox, explained in Art. 27.

**Float Measurements.**—When floats are used to determine the velocity, a uniform stretch of the stream is selected, and two cross sections chosen at a known distance apart. Floats are then put

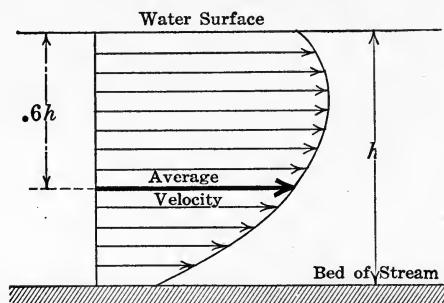

FIG. 107.

into the stream above the upper section and their times of transit from one section to the other observed by means of a stop watch. A sub-surface float is commonly used, so arranged that it can be run at any desired depth, its position being located by means of a small surface float attached to it.

If the cross section of the stream is fairly uniform, rod floats may be used. These consist of hollow tubes, so weighted as to float upright and extend nearly to the bottom. The velocity of the float may then be assumed to be equal to the mean velocity of the vertical strip through which it runs.

**Variation of Velocity with Depth.**—The results of such measurements show, in general, that the velocity of a stream is greatest midway between the banks and just beneath the surface. In

particular, the velocities at different depths along any vertical are found to vary as the ordinates to a parabola, the axis of the parabola being vertical and its vertex just beneath the surface, as indicated in Fig. 107. From this relation it follows that if a float is adjusted to run at about 0.6 of the depth in any vertical strip, it will move with approximately the average velocity of all the particles in the vertical strip through which it runs.

**Calculation of Discharge.**—In order to calculate the discharge it is necessary to measure the area of a cross section as well as the average velocities at various points of this section. The total cross section is therefore subdivided into parts, say  $A_1, A_2, A_3,$

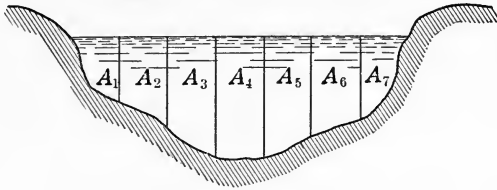

FIG. 108.

etc. (Fig. 108), the area of each being determined by measuring the ordinates by means of soundings. The average velocity for each division is then measured by one of the methods explained above, and finally the discharge is computed from the relation

$$Q = A_1v_1 + A_2v_2 + A_3v_3 + \dots$$

## 27. THE PITOT TUBE

**Description of Instrument.**—An important device for measuring the velocity of flow is the instrument known as the *Pitot tube*. In 1732 Pitot observed that if a small vertical tube, open at both ends, with one end bent at a right angle, was dipped in a current so that the horizontal arm was directed against the current as indicated in Fig. 109, *A*, the liquid rises in the vertical arm to a height proportional to the velocity head. The height of the column sustained in this way, or hydrostatic head, is not exactly equal to the velocity head on account of the disturbance created by the presence of the tube. No matter how small the tube may be, its dimensions are never negligible, and its presence has the effect of causing the filaments of liquid, or stream lines, to curve

around it, thereby considerably modifying the pressure. Since the column of liquid in the tube is sustained by the impact of the current, this arrangement is called an *impact tube*.

If a straight vertical tube is submerged, or a bent tube having its horizontal arm directed transversely, that is, perpendicularly, to the current, the presence of the tube causes the stream lines to turn their concavity toward the orifice, thereby producing a suction which is made apparent by a lowering of the water level in this tube, as shown in Fig. 109, *B*. In the case of the bent tube, if the horizontal arm is directed with the current, as shown in Fig.

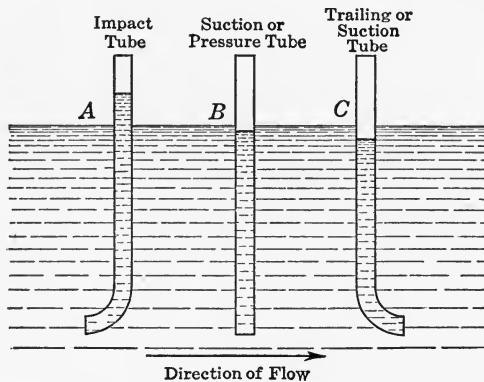

FIG. 109.

109, *C*, the suction effect is more pronounced, and the level in the tube is still further lowered. When the horizontal arm of a bent tube is directed with the current, the arrangement is called a *suction* or *trailing tube*.

It is practically impossible, however, to obtain satisfactory numerical results with this simple type of Pitot tube, as in the case of flow in open channels the free surface of the liquid is usually disturbed by waves and ripples and other variations in level, which are often of the same order of magnitude as the quantities to be measured; while in the case of pipe flow under pressure there are other conditions which strongly affect the result, as will appear in what follows.

**Darcy's Modification of Pitot's Tube.**—In 1850 Darcy modified the Pitot tube so as to adapt it to general current measurements. This modification consisted in combining two Pitot tubes, as shown in Fig. 110, the orifice of the impact tube being directed

up stream, and the orifice of the suction tube transverse to the current. In some forms of this apparatus, the suction tube is of the trailing type, that is, the horizontal arm is turned directly down stream.

To make the readings more accurate, the difference in elevation of the water in the two tubes is magnified by means of a differential gage, as shown in Fig. 110. Here *A* denotes the impact tube and *B* the suction tube (often called the pressure tube), connected with the tubes *C* and *D*, between which is a graduated scale. After placing the apparatus in the stream to be gaged, the air in both tubes is equally rarified by suction at *F*, thereby causing the water level in both to rise proportional amounts. The valve at *F* is then closed, also the valve at *E*, and the apparatus is lifted from the water and the reading on the scale taken.

It was assumed by Pitot and Darcy that the difference in level in the tubes was proportional to the velocity head  $\frac{v^2}{2g}$ , where *v* denotes the velocity of the current. Calling *h*<sub>1</sub> and *h*<sub>2</sub> the difference in level, that is, the elevation or depression of the water in the impact and suction tubes respectively, and *m*<sub>1</sub>, *m*<sub>2</sub> the constants of proportionality, we have therefore

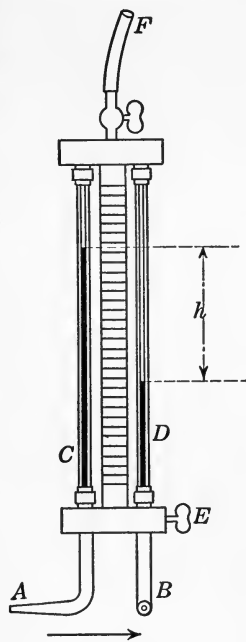

FIG. 110.

$$m_1 h_1 = \frac{v^2}{2g} = m_2 h_2.$$

If, then, *h* denotes the difference in elevation in the two tubes (Fig. 110), we have

$$h = h_1 + h_2 = \frac{v^2}{2g} \left( \frac{1}{m_1} + \frac{1}{m_2} \right).$$

The velocity *v* is therefore given in terms of *h* by the equation

$$v = m \sqrt{2gh} \tag{69}$$

where

$$m = \sqrt{\frac{m_1 m_2}{m_1 + m_2}}.$$

The coefficient  $m$  depends, like  $m_1$  and  $m_2$ , on the form and dimensions of the apparatus, and when properly determined is a constant for each instrument, provided that the conditions under which the instrument is used are the same as those for which  $m$  was determined.

The value of  $m$  in this formula has been found to vary from 1 to as low as 0.7; the value  $m = 1$  corresponding to  $h = \frac{v^2}{2g}$ ; and

the value  $m = 0.7$  to  $h = \frac{v^2}{g}$ .

The explanation of this apparent discrepancy is given below under the theory of the impact tube.

In the case of variable velocity of flow it has been shown by Rateau<sup>1</sup> that the Pitot, or Darcy, tube measures not the mean velocity but the mean of the squares of the velocities at the point where it is placed during the experiment. To obtain the mean velocity it is necessary to multiply  $\frac{v^2}{2g}$  by a coefficient which varies according to the rate of change of the velocity with respect to the time. From Rateau's experiments this coefficient was found to vary from 1.012 to 1.37, having a mean value of

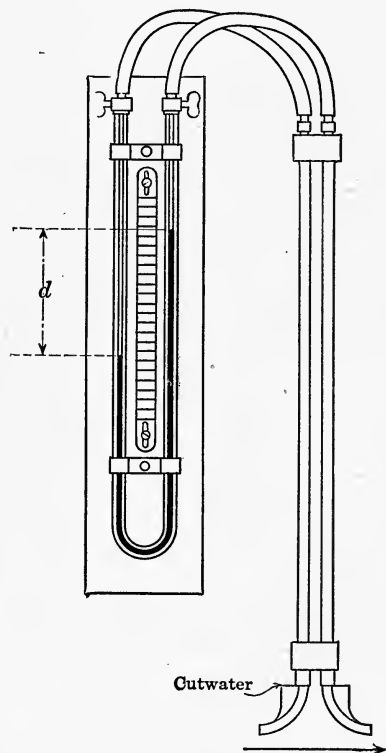

FIG. 111.

1.15. This corresponds to a mean value for  $m$  of 0.93.

**Pitometer.**—A recent modification of the Pitot tube is an instrument called the *Pitometer* (Fig. 111). The mouth-piece of this apparatus consists of two small orifices pointing in opposite directions and each provided with a cut-water, as shown in the figure. When in use, these are set in line parallel to the current,

<sup>1</sup> Annales des Mines, Mars, 1898.

so that one points directly against the current and the other with it. The differential gage used with this instrument consists of a U-tube, one arm of which is connected with one mouthpiece and the other arm with the other mouthpiece, and which is about half filled with a mixture of gasoline and carbon tetrachloride, colored dark red. The formula for velocity as measured by this instrument is given in the form

$$v = k[2g(s - 1)d]^{1/2}$$

where  $k$  = empirical constant = 0.84 for the instrument as manufactured and calibrated,

$s$  = specific weight of the tetrachloride mixture = 1.25,

$d$  = difference in elevation in feet between the tops of the two columns of tetrachloride.

Inserting these numerical values, the formula reduces to

$$v = 3.368 \sqrt{d}.$$

It is claimed that velocities as low as 1/2 ft. per second can be measured with this instrument.

**Pitot Recorders.**—The Pitot meter is used in power houses, pumping stations and other places where a Venturi tube cannot be installed, and is invaluable as a water-works instrument to determine the pipe flow in any pipe of the system.

A recent portable type, especially adapted to this purpose is shown in Fig. 112. This instrument is 34 in. high, weighs 75 lb., and furnishes a chart of the Bristol type which are averaged with a special planimeter furnished with the instrument. A 1-in. tap in the water main is required for inserting the Pitot mouthpiece.

It is claimed that these instruments have a range from 1/2 ft. per second to any desired maximum.

**Theory of the Impact Tube.**—The wide variation in the range of coefficients recommended by hydraulic engineers for use with the Pitot tube can be accounted for only on the ground of a faulty understanding of the hydraulic principles on which its action is based. The most important of these are indicated below, without presuming to be a complete exposition of its action.

It will be shown in Art. 29 that the force produced by the impact of a jet on a flat plate is twice as great as that due to the hy-

drostatic head causing the flow. That is to say, if the theoretical velocity of a jet is that due to a head  $h$ , where

$$h = \frac{v^2}{2g},$$

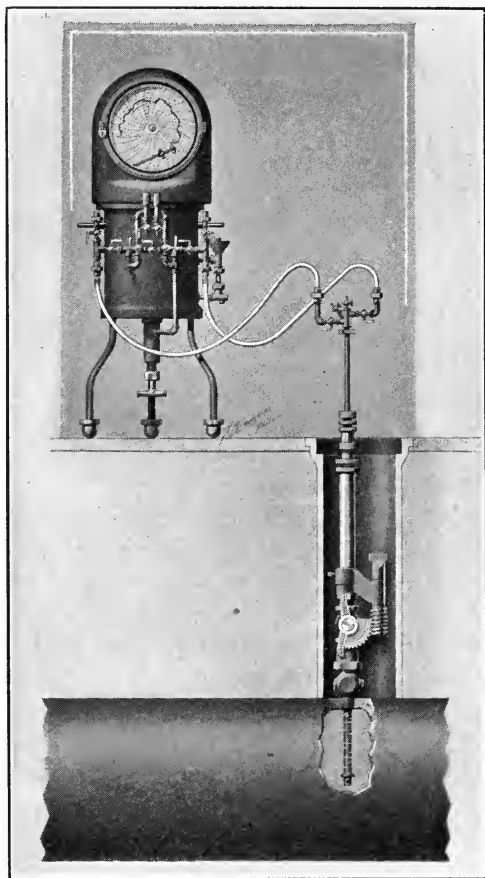

FIG. 112.—Pitot recording meter, Simplex Valve and Meter Co.

the force exerted on a fixed plate by the impact of this jet is equal to that due to a hydrostatic head of  $h' = 2h$ , in which case

$$h' = 2h = 2\left(\frac{v^2}{2g}\right) = \frac{v^2}{g}.$$

The orifice in a Pitot tube is essentially a flat plate subjected to the impact of the current. Considering only the impact effect,



therefore, the head which it is theoretically possible to attain in a Pitot tube is

$$h' = \frac{v^2}{g},$$

which corresponds to a value of  $m$  of 0.7 in the formula

$$v = m \sqrt{2gh}.$$

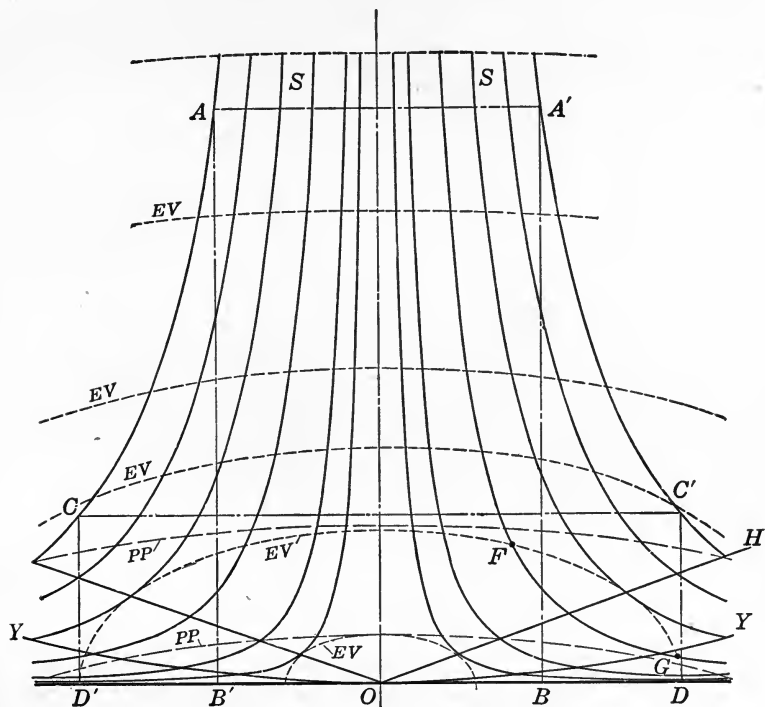

FIG. 113.

There are other considerations, however, which often modify this result considerably. The effect of immersing a circular plate in a uniform parallel current has been fully analyzed theoretically and the results confirmed experimentally. The results of such an analysis made by Professor Prasil, as presented in a paper by Mr. N. W. Akimoff,<sup>1</sup> are shown in Fig. 113. The diagram here shown represents a vertical section of

<sup>1</sup>Jour. Amer. Water Works Assoc., May, 1914.

a current flowing vertically downward against a horizontal circular plate.

The stream lines  $S$ , shown by the full lines in the figure, are curves of the third degree, possessing the property that the volumes of the cylinders inscribed in the surface of revolution generated by each stream line are equal. For instance, the volume of the circular cylinder shown in section by  $AA'BB'$  is equal to that of the cylinder  $CC'DD'$ , etc. It may also be noted that the size of the plate does not affect the general shape or properties of the curves shown in the diagram.

The surfaces of equal velocity are ellipsoids of revolution having the center of the plate  $O$  as center, and are shown in section in the figure by the ellipses marked  $EV$ . In general, each of these ellipses intersects any stream line in two points, such as  $F$  and  $G$ . Therefore somewhere between  $F$  and  $G$  there must be a point of minimum velocity, this being obviously the point of contact of the corresponding ellipse with the stream line. The locus of these points of minimum velocity is a straight line  $OH$  in section, inclined to the plate at an angle of approximately  $20^\circ$ . The surface of minimum velocity is therefore a cone of revolution with center at  $O$ , of which  $OH$  is an element.

The surfaces of equal pressure are also ellipsoids of revolution with common center below  $O$ , and are shown in section by the ellipses marked  $PP$  in the figure. The surface of maximum pressure is a hyperboloid of revolution of one sheet, shown in section by the hyperbola  $YOY$ .

It should be especially noted that the cone of minimum velocity is distinct from the hyperboloid of maximum pressure so that in this case minimum velocity does not necessarily imply maximum pressure, as might be assumed from a careless application of Bernoulli's theorem.

This analysis shows the reason for the wide variation in the results obtained by different experimenters with the Pitot tube, and makes it plain that they will continue to differ until the hydraulic principles underlying the action of the impact tube are generally recognized and taken into account.

**Construction and Calibration of Pitot Tubes.**—The impact end of a Pitot tube is usually drawn to a fine point with a very small orifice, whereas the vertical arm is given a much larger diameter in order to avoid the effect of capillarity. The tubes used by Darcy had an orifice about 0.06 in. in diameter which was

enlarged in the vertical arm to an inside diameter of about 0.4 in. In his well-known experiments for determining the velocity of fire streams (Art. 21), Freeman used for the mouthpiece of his impact tube the tip of a stylographic pen, having an aperture 0.006 in. in diameter. With this apparatus and for the high velocities used in the tests, the head was found to be almost exactly equal to  $\frac{v^2}{2g}$ , corresponding to a value of  $m = 1.0$  in the formula  $v = m \sqrt{2gh}$ .

It is also important that the impact arm should be long enough so that its orifice is clear of the standing wave produced by the current flowing against the vertical arm. The cutwater used with some forms of apparatus (see Fig. 111) is intended to eliminate this effect but it is doubtful just how far it accomplishes its purpose.

The most prolific source of error in Pitot-tube measurements is in the calibration of the apparatus. The fundamental principle of calibration is that the tube must be calibrated under the same conditions as those for which it is to be used. Thus it has been shown in Art. 16 that flow below the critical velocity follows an entirely different law from that above this velocity. Flow in a pipe under pressure is also essentially different from flow in an open channel.

**Du Buat's Paradox.**—Furthermore, the *method* of calibration is of especial importance. This is apparent from the well-known hydraulic principle known as *Du Buat's paradox*. By experiment Du Buat has proved that the resistance, or pressure, offered by a body moving with a velocity  $v$  through a stationary liquid is quite different from that due to the liquid flowing with the same velocity  $v$  past a stationary object. The pressure of the moving liquid on the stationary object was found by him to be greater than the resistance experienced by the moving object in a stationary liquid in the ratio of 13 to 10. All methods of calibration which depend on towing the instrument through a liquid at rest therefore necessarily lead to erroneous and misleading results.

Since the Pitot tube is so widely used for measuring velocity of flow, its construction and calibration should be standardized, so that results obtained by different experimenters may be subject to comparison, and utilized for a more accurate and scientific construction of the instrument.

## 28. NON-UNIFORM FLOW; BACKWATER

**Energy Equation for Stream of Variable Depth.**—In Art. 24 it is shown that steady, uniform flow implies constant slope and cross section of the channel, in which case the velocity and depth of water are also constant. In the case of natural channels, however, the cross section is never uniform but varies from point to point, in consequence of which the flow is non-uniform, both the velocity and hydraulic radius changing with the depth.

For a stream with free upper surface, the hydraulic gradient coincides with the water surface, and consequently the drop in the water surface in any distance  $l$  measures the head lost in this distance.

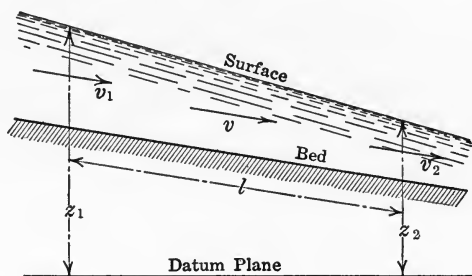

FIG. 114.

Now consider two adjacent cross sections of a stream of variable depth (Fig. 114). Then by Bernoulli's theorem we have

$$z_1 + \frac{p_a}{\gamma} + \frac{v_1^2}{2g} = z_2 + \frac{p_a}{\gamma} + \frac{v_2^2}{2g} + h_l$$

where  $z_1$ ,  $z_2$  denote the elevations of the surface at the two sections considered above a horizontal datum plane, and  $h_l$  is the frictional head lost in the given distance  $l$ . Since the atmospheric pressure  $p_a$  is constant, this expression simplifies into

$$(z_2 - z_1) + \frac{v_2^2 - v_1^2}{2g} + h_l = 0.$$

An expression for the lost head  $h_l$  in terms of the average velocity  $v$  may be obtained from Chezy's formula, namely,

$$v = C \sqrt{rs},$$

for by squaring and transposing, it becomes

$$s = \frac{v^2}{C^2 r}$$

and since  $\frac{h_l}{l} = s$ , these two relations combine to give

$$h_l = \frac{lv^2}{C^2r}$$

Substituting this value of  $h_l$  in the above expression it takes the form

$$(z_2 + z_1) + \frac{v_2^2 - v_1^2}{2g} + \frac{lv^2}{C^2r} = 0. \quad (70)$$

**Differential Equation of Surface Profile.**<sup>1</sup>—To obtain the equation of a longitudinal profile of the surface, or surface curve

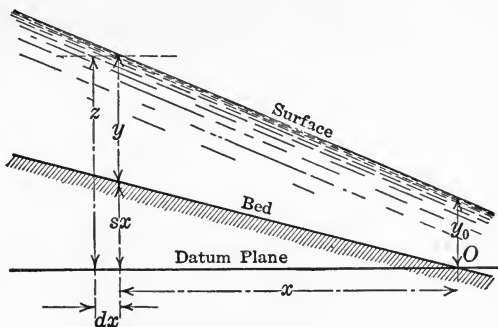

FIG. 115.

as it is called, let the distance between the two cross sections considered be infinitesimal, and denote this distance by  $dx$ . Then the difference in elevation  $z$  will also be infinitesimal, that is,  $z_2 - z_1 = -dz$ , and also  $v_2^2 - v_1^2 = d(v^2) = 2v dv$ , where  $d(v^2)$  is the ordinary differential notation indicating an infinitesimal change in  $v^2$ . Substituting these differential values in Eq. (70), it becomes

$$-dz + \frac{v dv}{g} + \frac{v^2 dx}{C^2 r} = 0, \quad (71)$$

which is therefore the differential equation of the surface curve.

Now take the origin on the down-stream side of the section at a distance  $x$  from it, and suppose the adjacent section to be at a distance  $x + dx$  from the origin, as indicated in Fig. 115. If  $s$  denotes the slope of the bed of the stream and  $y$  the depth of the

<sup>1</sup> The method here given for determining the equation of the surface curve is substantially that followed in all standard texts on hydraulics. For example, see Föppl, *Vorlesungen über Technische Mechanik*, Bd. 1.

water, the fall of the bed in the distance  $dx$  is  $sdx$  and the change in depth is  $dy$ . The latter, however, is negative since the slope of the surface is less than that of the bed, so that

$$dz = sdx - dy.$$

Also, if  $A$  denotes the area of the cross section with abscissa  $x$ ,  $b$  its average width, and  $Q$  the quantity of water flowing past this section per unit of time, then

$$\begin{aligned} A &= by, & dA &= bdy, \\ v &= \frac{Q}{A} = \frac{Q}{by}, & dv &= -\frac{Qdy}{by^2}. \end{aligned}$$

Substituting these values for  $dz$  and  $dv$  in Eq. (71), it becomes

$$dy - sdx - \frac{Q^2 dy}{gb^2y^3} + \frac{Q^2 dx}{b^2C^2ry^2} = 0. \quad (72)$$

**Back-water Curve for Broad Shallow Stream.**—The case of most practical importance is that in which the level of a stream is raised by means of a dam or weir, and it is required to determine the new elevation of the surface back of the dam or weir. In this case let  $h$  denote the original depth of the stream before the weir was built, or the depth below the weir after it is constructed (Fig. 116). Then assuming that the breadth of the stream and the total discharge remains unchanged, we have

$$Q = vbh = C\sqrt{r's}bh$$

where  $r'$  denotes the hydraulic radius for the original channel section. Substituting this value of  $Q$  in Eq. (72) it becomes

$$dy - sdx - \frac{C^2r'sb^2h^2dy}{gb^2y^3} + \frac{C^2r'sb^2h^2dx}{b^2C^2ry^2} = 0,$$

which simplifies into

$$dy \left( 1 - \frac{C^2r'sh^2}{gy^3} \right) = \left( 1 - \frac{r'h^2}{ry^2} \right) sdx. \quad (73)$$

If the stream is assumed to be shallow in comparison with its breadth, this expression can be greatly simplified. Since the expressions for the cross sections and hydraulic radii of the new channel and the original channel are

$$\begin{aligned} A &= by & r &= \frac{by}{b+2y}, \\ A' &= bh, & r' &= \frac{bh}{b+2h}, \end{aligned}$$

if  $y$  and  $h$  are small in comparison with the breadth  $b$ , the values of the hydraulic radii are approximately

$$r = y, r' = h.$$

Inserting these values of  $r, r'$  and  $A$  in Eq. (73) and multiplying through by  $\frac{y^3}{h^3}$ , it becomes

$$\left[ \left( \frac{y}{h} \right)^3 - \frac{C^2 s}{g} \right] dy = \left[ \left( \frac{y}{h} \right)^3 - 1 \right] s dx \quad (74)$$

which is the required differential equation of the backwater curve for the special case considered.

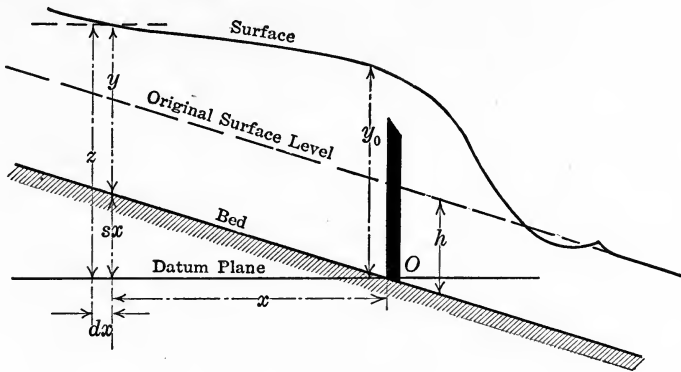

FIG. 116.

**Integration of Backwater Function.**—To integrate Eq. (74)

let  $\frac{y}{h} = u$ . Then  $dy = hdu$ , and Eq. (74) becomes

$$\left( u^3 - \frac{C^2 s}{g} \right) h du = (u^3 - 1) s dx,$$

which may be written in the form

$$\frac{s}{h} dx = \frac{u^3 - \frac{C^2 s}{g}}{u^3 - 1} du.$$

By ordinary division,

$$\frac{u^3 - \frac{C^2 s}{g}}{u^3 - 1} = 1 + \frac{1 - \frac{C^2 s}{g}}{u^3 - 1},$$

and consequently the above relation becomes

$$\frac{s}{h} dx = du + \left( 1 - \frac{C^2 s}{g} \right) \frac{du}{u^3 - 1}.$$

Now integrating between limits  $x_1$  and  $x_2$  for  $x$ , and corresponding limits  $u_1$  and  $u_2$  for  $u$ , we have

$$\frac{s}{h} \int_{x_2}^{x_1} dx = \int_{u_2}^{u_1} du + \left(1 - \frac{C^2 s}{g}\right) \int_{u_2}^{u_1} \frac{du}{u^3 - 1}. \quad (75)$$

The values of the first two integrals are simply

$$\int_{x_2}^{x_1} dx = x_1 - x_2 = l, \quad \int_{u_2}^{u_1} du = u_1 - u_2,$$

where  $l$  denotes the distance between the cross sections considered. For convenience let the remaining integral be denoted by  $\varphi(u)$ ; that is, let

$$\varphi(u) = - \int \frac{du}{u^3 - 1} = \frac{1}{6} \log \frac{u^2 + u + 1}{(u - 1)^2} - \frac{1}{\sqrt{3}} \cot^{-1} \left( \frac{2u + 1}{\sqrt{3}} \right).$$

Substituting the limits, we have in this notation

$$\int_{u_2}^{u_1} \frac{du}{u^3 - 1} = \varphi(u_1) - \varphi(u_2),$$

and therefore Eq. (75) becomes

$$\frac{sl}{h} = u_1 - u_2 - \left(1 - \frac{C^2 s}{g}\right) [\varphi(u_1) - \varphi(u_2)];$$

or, since  $\frac{y}{h} = u$ , we have  $y_1 = hu_1$ ,  $y_2 = hu_2$  and consequently this equation may be written

$$1 = \frac{l}{s}(y_1 - y_2) - \frac{h}{s} \left(1 - \frac{C^2 s}{g}\right) [\varphi(u_1) - \varphi(u_2)], \quad (76)$$

which is the required equation of the backwater curve.

**Values of Integral.**—To avoid the labor of calculating the numerical value of the integral  $\varphi(u)$  in any given case, the values of the integral corresponding to values of  $u$  ordinarily occurring in practice are tabulated below:<sup>1</sup>

<sup>1</sup> Bresse, *Mécanique Appliqués*, Vol. 2. Also given in Williamson's *Integral Calculus*; in Hoskin's *Text-book on Hydraulics*, and elsewhere.



Numerical values of $\varphi(u) = -\int \frac{du}{u^3 - 1}$							
$u$	$\varphi(u)$	$u$	$\varphi(u)$	$u$	$\varphi(u)$	$u$	$\varphi(u)$
1.00	$\infty$	1.10	0.680	1.30	0.373	1.65	0.203
1.01	1.419	1.12	0.626	1.32	0.357	1.70	0.189
1.02	1.191	1.14	0.581	1.34	0.342	1.80	0.166
1.03	1.060	1.16	0.542	1.36	0.328	1.90	0.147
1.04	0.967	1.18	0.509	1.38	0.316	2.00	0.1318
1.05	0.896	1.20	0.480	1.40	0.304	2.10	0.1188
1.06	0.838	1.22	0.454	1.45	0.278	2.20	0.1074
1.07	0.790	1.24	0.431	1.50	0.255	2.30	0.0978
1.08	0.749	1.26	0.410	1.55	0.235	2.40	0.0894
1.09	0.713	1.28	0.390	1.60	0.218	2.50	0.0822

**Condition for Singularities in Backwater Curve.**—If the constant  $C$  in Chezy's formula has the numerical value

$$C = 90 \text{ ft.}^{1/2} \text{ sec.}^{-1},$$

which may be assumed as its average value under ordinary conditions, then

$$\frac{C^2}{g} = 250, \text{ approximately.}$$

Consequently, when the slope  $s$  has the value

$$s = \frac{1}{250},$$

then

$$1 - \frac{C^2 s}{g} = 0$$

and Eq. (76) for the backwater curve reduces to

$$y_1 = y_2 + sl.$$

If the fall is steeper than  $\frac{1}{250}$ , there are singularities in the backwater curve. This is apparent from Eq. (72); for, writing it in the form

$$\frac{dy}{dx} = \frac{s - \frac{Q^2}{A^2 C^2 r}}{1 - \frac{Q^2 b}{g A^3}}$$

it is evident that the curve will have a vertical tangent, that is,  $\frac{dy}{dx} = \infty$ , if the denominator of this fraction is zero, that is, if

$$1 - \frac{Q^2 b}{g A^3} = 0.$$

But since  $Q = Av = byC\sqrt{ys}$ , this condition may be written

$$1 - \frac{b^2 y^2 C^2 y s b}{g b^3 y^3} = 0,$$

or, cancelling common factors,

$$1 - \frac{C^2 s}{g} = 0,$$

which is identical with the condition previously obtained. Consequently, if  $s > \frac{1}{250}$  approximately, there will be a sudden vertical drop in the backwater curve, whereas if  $s$  is less than this critical value,  $\frac{dy}{dx}$  is always negative and the curve contains no such singularity.

**Numerical Application.**—To illustrate the application of Eq. (76), suppose that on a certain river it is proposed to create a waterfall for a hydraulic power station by building a dam. Before proceeding with the construction it is required to know among other things whether the water can be raised 5 ft. at the dam without interfering with the operation of an existing power plant 7 miles up stream.

Suppose that the stream at the proposed site is 10 ft. deep and 500 ft. wide, the slope of its bed is 2 ft. per mile, and the maximum annual discharge is 25,000 cu. ft. per second. Then its mean velocity is

$$v = \frac{25,000}{500 \times 10} = 5 \text{ ft. per sec.},$$

the hydraulic radius for the given section is

$$r = \frac{500 \times 10}{500 + 20} = 9.6 \text{ ft.},$$

and the value of the constant  $C$  in Chezy's formula is

$$C = \frac{v}{\sqrt{rs}} = \frac{5}{\sqrt{9.6 \times \frac{2}{5280}}} = 82.9.$$

First, let it be required to find how far up stream the increase in depth will amount to 2 ft. From the given data,

$$h = 10, \quad s = \frac{2}{5280}, \quad C = 82.9, \quad y_1 = 15, \quad y_2 = 12,$$

$$u_1 = \frac{15}{10} = 1.5, \quad u_2 = \frac{12}{10} = 1.2,$$

and from the table for  $\varphi(u)$  on page 123,

$$\varphi(u_1) = 0.255, \quad \varphi(u_2) = 0.480.$$

Substituting these numerical values in Eq. (76) it becomes

$$l = \frac{5280}{2}(15 - 12) - 10 \left( \frac{5280}{2} \right) \left[ 1 - \frac{82.9^2}{\frac{5280}{2} \times 32.2} \right] (0.255 - 0.480) = 13,385 \text{ ft.} = 2\text{-}1/2 \text{ miles.}$$

Second, to find the increase in depth at the existing plant 7 miles up stream, the given data are

$$h = 10, \quad s = \frac{2}{5280}, \quad C = 82.9, \quad y_1 = 15, \quad u_1 = 1.5,$$

$$\varphi(u_1) = 0.255, \quad l = 7(5280),$$

the unknown quantities being  $y_2$  and  $\varphi(u_2)$ . Substituting the known quantities in Eq. (76), it becomes

$$36,960 = \frac{5280}{2}(15 - y_2) - \frac{10 \times 5280}{2} \left[ 1 - \frac{82.9^2 \frac{2}{5280}}{32.2} \right] [0.255 - \varphi(u_2)]$$

which reduces to

$$9.2\varphi(u_2) = y_2 + 1.346.$$

This equation can best be solved by trial by assuming a value for  $y_2$ , taking the corresponding value of  $\varphi(u_2)$  from the table, and substituting these trial values in the equation. Thus, assuming the rise to be 0.2 ft., we have

$$y_2 = 10.2, \quad u_2 = \frac{10.2}{10} = 1.02, \quad \varphi(u_2) = 1.191,$$

and the left member of the equation becomes

$$9.2\varphi(u_2) = 10.957,$$

whereas the right member is

$$y_2 + 1.346 = 11.546.$$

Similarly, assuming the rise to be 0.1 ft., we have

$$y_2 = 10.1, u_2 = \frac{10.1}{10} = 1.01, \varphi(u_2) = 1.419,$$

and the left member now becomes

$$9.2\varphi(u_2) = 13.055,$$

whereas the right member is

$$y_2 + 1.346 = 11.446.$$

It is evident, therefore, that the actual rise in surface elevation at the given point is slightly less than 0.2 ft.

#### APPLICATIONS

**51.** A device used by Prony for measuring discharge consists of a fixed tank *A* (Fig. 117) containing water, in which floats a cylinder *C* which carries a second tank *B*. Water flows through the opening *D* from *A* into *B*. Show that the head on the opening *D*, and consequently the velocity of flow through this opening, remains constant. (Wittenbauer.)

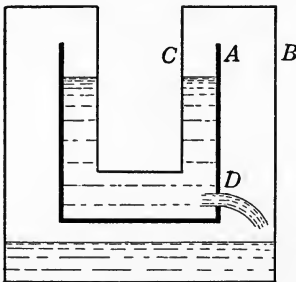

FIG. 117.

**52.** A cylindrical tank of 6 ft. inside diameter and 10 ft. high contains 8 ft. of water. An orifice 2 in. in diameter is opened in the bottom, and it is found that the water level is lowered 21 in. in 3 minutes. Calculate the coefficient of discharge.

**53.** Water flows through a circular sharp-edged orifice 1/2 in. in diameter in the side of a tank, the head on the center of the opening being 6 ft. A ring slightly larger than the jet is held so that the jet passes through it, and it is then found that the center of the ring is 3 ft. distant from the orifice horizontally, and 8.23 ft. below it. In 5 minutes the weight of water discharged is 301 lb. Calculate the coefficients of velocity, contraction and discharge for this orifice.

*Note.*—This is an interesting method of determining the coefficients by experiment but is not very accurate.

If the velocity of the jet at exit is denoted by  $v$ , its abscissa  $x$  after  $t$  seconds will be approximately

$$x = vt$$

and the ordinate of the same point, considering the water as a freely falling body, will be

$$y = \frac{1}{2}gt^2.$$

Eliminating  $t$  between these two relations, the equation of the path followed by the jet is found to be

$$x^2 = \frac{2v^2y}{g},$$

which represents a parabola with axis vertical and vertex at the orifice. Having found the actual velocity  $v$  from this equation, the velocity coefficient is obtained from the relation

$$C_v = \frac{v}{\sqrt{2gh}}.$$

The efflux coefficient  $K$  is then calculated from the measured discharge  $Q$  from the relation

$$Q = KAv,$$

and the contraction coefficient from

$$C_c = \frac{K}{C_v}.$$

**54.** Find the velocity with which water will flow through a hole in a steam boiler shell at a point 2 ft. below the surface of the water when the steam pressure gage indicates 70 lb. per square inch.

**55.** A reservoir having a superficial area of 0.5 sq. mile has an outlet through a rectangular notch weir 8 ft. long. If the head on the crest when the weir is opened is 2.5 ft., how long will it take to lower the level of the reservoir 1 ft.?

**56.** A rectangular notch weir 12 ft. long has a head of 15 in. of water on the crest. The cross-sectional area of the approach channel is 50 sq. ft. Calculate the flow.

**57.** A suppressed weir 6 ft. long has its crest 3 ft. above the bottom of the channel, and the head on the crest is 18 in. Compute the discharge.

58. A lock chamber 500 ft. long and 110 ft. wide is emptied through a submerged opening 6 ft. long by 3 ft. high, having a coefficient of discharge of 0.58. If the depth of water on the center of the opening is initially 30 ft. on the inside and 8 ft. on the outside, find how long it will take to lower the water in the lock to the outside level.

59. A hemisphere filled with water has a small orifice of area  $A$  at its lowest point. Calculate the time required for it to empty.

*Note.*—If  $x$  denotes the depth of water at any instant, the area  $X$  of the water surface is  $X = \pi(2rx - x^2)$ , where  $r$  denotes the radius of the hemisphere. The time required to empty the hemisphere is therefore

$$t = \frac{1}{KA\sqrt{2g}} \int_0^r \frac{X dx}{\sqrt{x}} = \frac{14}{15} \frac{\pi r^{5/2}}{KA\sqrt{2g}}.$$

60. A tank 10 ft. square and 12 ft. deep is filled with water. A sharp-edged circular orifice 3 in. in diameter is then opened in the bottom. How long will it take to empty the tank through this opening?

61. Compute the discharge through a Borda mouthpiece 1.5 in. in diameter under a head of 12 ft., and determine the loss of head in feet.

62. Compute the discharge through a re-entrant short tube 2 in. in diameter under a head of 20 ft., and determine the loss of head in feet.

63. Compute the discharge through a standard short tube of 1.75 in. inside diameter under a head of 6 ft., and also find the negative pressure head at the most contracted section of the vein.

64. Find the discharge in gallons per minute through a 1.5 in. smooth fire nozzle attached to a 2.5 in. play pipe under a pressure at base of nozzle of 90 lb. per square inch.

65. Water flows through a 6-in. horizontal pipe at 200 ft. per minute under a pressure of 30 lb. per square inch. If the pipe gradually tapers to 4 in. diameter, find the pressure at this point.

66. A 12-in. horizontal pipe gradually tapers to a diameter of 6 in. If the flow is 50,000 gal. per hour, calculate the difference in pressure at two sections having these diameters.

67. A Venturi meter in an 18-in. main tapers to 6 in. at the throat, and the difference in pressure in main and throat is equivalent to 11 in. of mercury. Find the discharge in gallons per minute.

68. The Ashokan Venturi meter on the line of the Catskill Aqueduct is 7 ft. 9 in. inside diameter at the throat, the diameter of the main being 17 ft. 6 in. (see Fig. 71, page 69). Find the difference in pressure between main and throat for the estimated daily flow of 500,000,000 gal.

69. The velocity of flow in a water main 4 ft. in diameter is 3.5 ft. per second. Assuming the coefficient of friction to be 0.0216, find the frictional head lost in feet per mile.

70. Two cylindrical tanks each 8 ft. in diameter are connected near the bottom by a 2-in. horizontal pipe 25 ft. long. If the water level in one tank is initially 12 ft. and in the other 3 ft. above the center line of the pipe, find how long it will take for the water to reach the same level in both tanks.

71. Find the frictional head lost in a pipe 2 ft. in diameter and 5 miles long which discharges 200,000 gal. per hour, assuming the coefficient of friction to be 0.024.

72. Find the required diameter for a cast-iron pipe 10 miles long to discharge 60,000 gal. per hour under a head of 200 ft.

73. A house service pipe is required to supply 4000 gal. per hour through a 1.5-in. pipe and a 1-in. tap. The total length of the service pipe is 74 ft., including the tap which is 1.5 ft. long. Find the total pressure required in the main.

*Solution.*—In the solution of water-supply problems of this type, it is recommended by W. P. Gerhard<sup>1</sup> that the following formulas be used.

$$\text{Head lost in tap, } h_t = 0.024 \left(\frac{l}{d}\right) \frac{v^2}{2g},$$

$$\text{Head lost at entrance, } h_i = 0.62 \frac{v^2}{2g},$$

$$\text{Head lost at stopcock} = 1/2 \text{ head lost in tap,}$$

$$\text{Head lost in pipe by Prony's formula,}$$

$$G = \left[ \frac{(3d)^5 H}{L} \right]^{1/2} (1.20032)$$

where, in this last formula,

$d$  = diameter of pipe in inches,

$H$  = head in feet,

$L$  = length in yards,

$G$  = discharge in U. S. gal. per minute.

<sup>1</sup> Discharge of Water through Street Taps and House Service Pipes, *Cassier's Mag.*, Nov., 1905.

Using these formulas we obtain in the present case the following numerical results:

Pressure lost in tap	=	2.24 lb. per square inch.
Pressure lost at stopcock	=	1.12 lb. per square inch.
Pressure lost at entrance	=	3.08 lb. per square inch.
Pressure lost in 72.5 ft. of 1-in. pipe	=	17.53 lb. per square inch.
Total pressure required in main	=	23.97 lb. per square inch.

**74.** A building is to be supplied with 2500 gal. of water per hour through 180 ft. of service pipe at a pressure at the building line of 15 lb. per square inch. The pressure in the main is 35 lb. per square inch. Find the required size of service pipes and taps.

*Solution.*—The total drop in pressure in this case is 20 lb. per square inch. Therefore using the formulas given in the preceding problem and assuming different sizes of service pipes, the results are as follows:

One 1.25-in. full-size pipe 180 ft. long discharges 1715 gal. per hour.

Two 1-in. full-size pipes discharge together 1920 gal. per hour.

Two 1.25-in. pipes with 5/8-in. taps discharge together 2880 gal. per hour.

One 1.5-in. pipe with 1-in. tap discharges 2519 gal. per hour.

The last has sufficient capacity and is cheapest to install, and is therefore the one to be chosen.

**75.** A pipe 1 ft. in diameter connects two reservoirs 3 miles apart and has a slope of 1 per cent. Assuming the coefficient of friction as 0.024, find the discharge and the slope of the hydraulic gradient when the water stands 30 ft. above the inlet end and 10 ft. above the outlet end.

**76.** Two reservoirs 5 miles apart are connected by a pipe line 1 ft. in diameter, the difference in water level of the two reservoirs being 40 ft. Assuming the value of Chezy's constant in feet and second units to be 125, find the discharge in gallons per hour.

**77.** A 12-in. main 5000 ft. long divides into three other mains, one 6 in. in diameter and 6000 ft. long, one 10 in. in diameter and 7000 ft. long, and one 8 in. in diameter and 4000 ft. long. The total static head lost in each line between reservoir and outlet is the same and equal to 100 ft. Find the discharge in gallons per 24 hours at each of the three outlets.



*Solution.*—The head lost in friction in the length  $l$  is given by the relation

$$h_f = f \left( \frac{l}{d} \right) \frac{v^2}{2g},$$

and the discharge by

$$Q = \frac{\pi d^2}{4} v.$$

Eliminating  $v$  between these relations, we have

$$h_f = \frac{16flQ^2}{2gd\pi^2d^4},$$

whence

$$Q = \sqrt{\frac{g\pi^2d^5}{8fl}} \sqrt{h_f}.$$

Assuming  $f = 0.02$  and  $l = 1000$  ft., the discharge  $Q$  for pipes of various sizes in terms of the head lost per 1000 ft. is given by the following relations:

Diameter of pipe in inches	Discharge in gal. per 24 hours in terms of head lost per 1000 ft.
4	$Q = 58,430 \sqrt{h_f}$
6	$= 161,000 \sqrt{h_f}$
8	$= 330,500 \sqrt{h_f}$
10	$= 577,500 \sqrt{h_f}$
12	$= 911,000 \sqrt{h_f}$
16	$= 1,870,000 \sqrt{h_f}$
20	$= 3,266,000 \sqrt{h_f}$
24	$= 5,147,000 \sqrt{h_f}$
30	$= 9,002,000 \sqrt{h_f}$
36	$= 14,200,000 \sqrt{h_f}$
48	$= 29,150,000 \sqrt{h_f}$
56	$= 42,850,000 \sqrt{h_f}$
60	$= 50,920,000 \sqrt{h_f}$
66	$= 64,600,000 \sqrt{h_f}$
72	$= 80,320,000 \sqrt{h_f}$

In the present case let the flow in gallons per 24 hours be denoted by  $Q$  with a subscript indicating the size of pipe. Then

$$Q_{12} = Q_6 + Q_8 + Q_{10}.$$

Also if  $h$  with the proper subscript denotes the head lost in each pipe per 1000 ft., we have from the above relations

$$Q_{12} = 911,000 \sqrt{h_{12}},$$

$$Q_6 = 161,000 \sqrt{h_6},$$

$$Q_8 = 330,500 \sqrt{h_8},$$

$$Q_{10} = 577,500 \sqrt{h_{10}},$$

and since from the conditions of the problem the head lost in each line amounts to 100 ft., we also have the relations

$$5h_{12} + 6h_6 = 100,$$

$$5h_{12} + 7h_{10} = 100,$$

$$5h_{12} + 4h_8 = 100.$$

From these relations we find

$$h_8 = \frac{6}{4}h_6; \quad h_{10} = \frac{6}{7}h_6; \quad h_{12} = \frac{100 - 6h_6}{5},$$

and substituting these values in the first equation, the result is

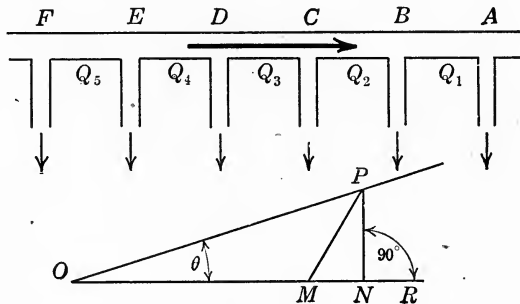

FIG. 118.

$$\begin{aligned} 161,000 \sqrt{h_6} + 330,500 \sqrt{\frac{6}{4}h_6} + 577,500 \sqrt{\frac{6}{7}h_6} \\ = 911,000 \sqrt{\frac{100 - 6h_6}{5}} \end{aligned}$$

whence  $h_6 = 7.52$  and consequently

$$h_8 = 12.28; \quad h_{10} = 6.446; \quad h_{12} = 10.976.$$

Substituting these values of  $h$  in the formulas for discharge, the results are

$$Q_6 = 444,360 \text{ gal. per 24 hr.}$$

$$Q_8 = 1,110,480 \text{ gal. per 24 hr.}$$

$$Q_{10} = 1,465,700 \text{ gal. per 24 hr.}$$

$$Q_6 + Q_8 + Q_{10} = 3,020,540 \text{ gal. per 24 hr.}$$

The actual calculated value of  $Q_{12}$  is

$$Q_{12} = 3,015,400 \text{ gal. per 24 hr.,}$$

the discrepancy between these results being due to slight inaccuracy in extracting the square roots.

78. A pipe of constant diameter  $d$  discharges through a number of laterals, each of area  $A$  and spaced at equal distances  $l$  apart (e.g., street main and house service connections). Find the relation between the volume of flow in three successive segments of the main<sup>1</sup> (Fig. 118).

*Solution.*—The discharge at  $A$  is

$$Q_1 = KA \sqrt{2gh} = \frac{\pi d^2}{4} v_1$$

where  $v_1$  denotes the velocity of flow at this point. Also the head lost in friction in the segment  $AB$  is

$$h_l = f \left( \frac{l}{d} \right) \frac{v_1^2}{2g}$$

and consequently

$$h_l = aQ_1^2$$

where

$$a = \frac{8fl}{g\pi^2 d^5}$$

At  $B$  the pressure head is  $h + h_l$  and the discharge is

$$Q_2 - Q_1 = KA \sqrt{2g} \sqrt{h + h_l} = KA \sqrt{2g} \sqrt{h + aQ_1^2}.$$

Similarly, for the discharge at  $C$  and  $D$  we obtain the relations

$$\begin{aligned} Q_3 - Q_2 &= KA \sqrt{2g} \sqrt{h + a(Q_1^2 + Q_2^2)}, \\ Q_4 - Q_3 &= KA \sqrt{2g} \sqrt{h + a(Q_1^2 + Q_2^2 + Q_3^2)}, \end{aligned}$$

whence by elimination

$$(Q_4 - Q_3)^2 - (Q_3 - Q_2)^2 = b^2 Q_3^2$$

where

$$b^2 = \frac{16fK^2}{\pi^2} \times \frac{Al}{d^5}.$$

The general relation is therefore

$$(Q_n - Q_{n-1})^2 - (Q_{n-1} - Q_{n-2})^2 = b^2 Q_{n-1}^2.$$

The following geometrical construction may be used for determining  $Q_n$ . Determine an angle  $\theta$  such that

$$b = \tan \theta$$

<sup>1</sup> J. P. Frizell, *Jour. Franklin Inst.*, 1878.

and lay off  $Q_{n-1}$  and  $Q_{n-2}$  on a straight line so that  $OM = Q_{n-2}$  and  $ON = Q_{n-1}$  as shown in Fig. 118. At  $N$  erect a perpendicular  $NP$  to  $ON$ , and then lay off  $NR = MP$ . Then  $OR = Q_n$ .

**79.** A reservoir discharges through a pipe line made up of pipes of different sizes, the first section being 4000 ft. of 24-in. pipe, followed by 5000 ft. of 20-in. pipe, 6000 ft. of 16-in. pipe and 7000 ft. of 12-in. pipe. The outlet is 100 ft. below the level of the reservoir. Find the discharge in gallons per 24 hours.

*Solution.*—Using the same notation as in Problem 77, we have in the present case

$$4h_{24} + 5h_{20} + 6h_{16} + 7h_{12} = 100.$$

Also, since

$$h_l = \left( \frac{8fl}{g\pi^2 d^5} \right) Q^2,$$

the loss in head per 1000 ft. varies inversely as the fifth power of the diameter, and consequently

$$h_{12} = \left( \frac{24}{12} \right)^5 h_{24} = 32 h_{24},$$

$$h_{16} = \left( \frac{24}{16} \right)^5 h_{24} = 7.594 h_{24},$$

$$h_{20} = \left( \frac{24}{20} \right)^5 h_{24} = 2.488 h_{24}.$$

Solving these three equations simultaneously with the first one, the results are

$$h_{24} = 0.35; h_{20} = 0.871; h_{16} = 2.658; h_{12} = 11.20.$$

As a check on the correctness of these results we have

$$4 \times 0.35 = 1.400$$

$$5 \times 0.871 = 4.355$$

$$6 \times 2.658 = 15.948$$

$$7 \times 11.20 = 78.400$$

---

$$100.103$$

The discharge may be found from the formulas given in Problem 77, the results being as follows:

$$Q_{12} = Q_{16} = Q_{20} = Q_{24} = 3,046,000 \text{ gal. per 24 hr.}$$

**80.** A pipe  $AB$ , 1000 ft. in length, divides at  $B$  into two pipes,  $BC$  which is 600 ft. long and  $BD$  which is 900 ft. long. The

fall for  $AB$  is 25 ft., for  $BC$  is 10 ft. and for  $BD$  is 20 ft. Find the required diameters of the three pipes to deliver 500 gal. per minute at  $C$  and 300 gal. per minute at  $D$ .

81. A reservoir empties through a pipe  $AB$  (Fig. 119) which branches at  $B$  into two pipes  $BC$  and  $BD$ , one of which discharges

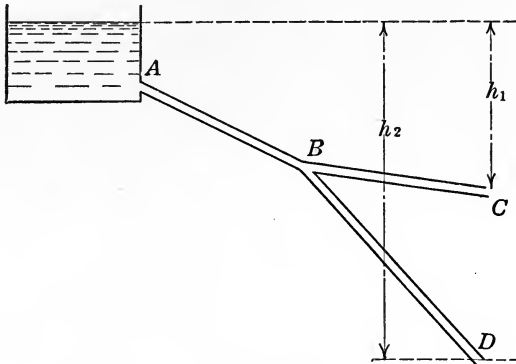

FIG. 119.

20,000 gal. per hour at  $C$  and the other 30,000 gal. per hour at  $D$ . The lengths of the pipes are  $AB = 1200$  ft.,  $BC = 900$  ft.,  $BD = 600$  ft., and the depths of the outlets below the surface of the reservoir are  $h_1 = 25$  ft.,  $h_2 = 60$  ft. The pipes are of cast iron,

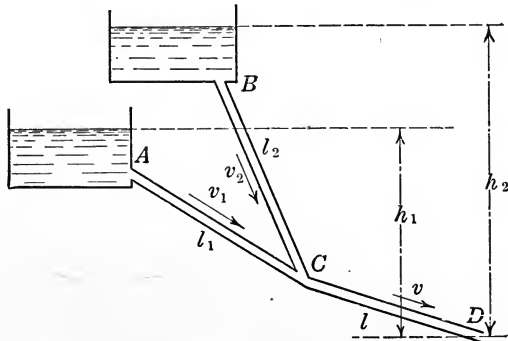

FIG. 120.

and the velocity of flow in  $AB$  is to be 3 ft. per second. Calculate the diameters of all three, and the velocity of flow in  $BC$  and  $BD$ .

82. Two reservoirs empty through pipes which unite at  $C$  (Fig. 120) into a single pipe which discharges at  $D$ . The lengths

of the pipes are  $l_1 = 1500$  ft.,  $l_2 = 900$  ft. and  $l = 2400$  ft. The diameters of the pipes are  $d_1 = 6$  in.,  $d_2 = 4$  in., and  $d = 9$  in., and the depths of the outlet below the levels of the reservoirs are  $h_1 = 75$  ft.,  $h_2 = 100$  ft. Find the velocity of flow in each pipe and the total discharge in gallons per hour.

83. A water main 3 ft. in diameter divides into two smaller mains of the same diameter and whose combined area equals that of the large main. If the velocity of flow is 3 ft. per second, compare the heads lost per mile in the large and small mains.

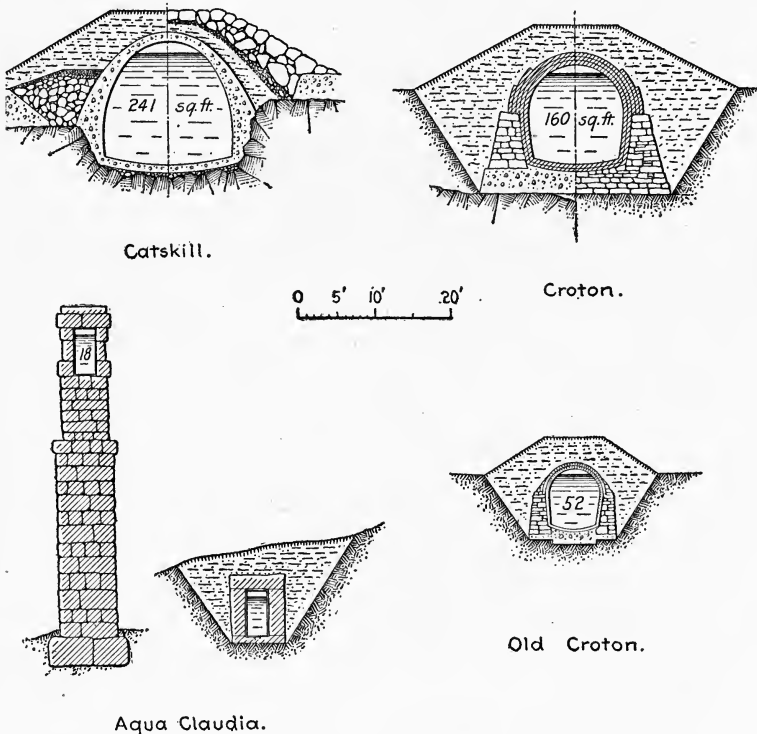

FIG. 121.—Comparison of ancient and modern aqueducts.

84. The head on a fire hydrant is 300 ft. Find its discharge in gallons per minute through 400 ft. of inferior rubber-lined cotton hose 2.5 in. in diameter and a 1.5-in. smooth nozzle.

85. What head is required at a fire hydrant to discharge 250 gal. per minute through a 1.25-in. ring nozzle and 500 ft. of 2.5-in. best rubber-lined cotton hose?

86. A fire stream is delivered through 100 ft. of 2-in. rubber-lined cotton hose and a nozzle 1-1/8 in. in diameter. The hydrant pressure is 75 lb. per square inch. Find pressure at nozzle, discharge in gallons per minute and height of effective fire stream.

87. Two reservoirs are connected by a siphon 16 in. in diameter and 50 ft. long. If the difference in level in the reservoirs is 25 ft., calculate the discharge, assuming the coefficient of pipe friction to be 0.02 and considering only friction losses.

88. A cast-iron pipe 2 ft. in diameter has a longitudinal slope of 1 in 2500. If the depth of water in the pipe is 18 in., calculate the discharge.

89. A rectangular flume 6 ft. wide, 3 ft. deep and 1 mile long is constructed of unplanned lumber and is required to deliver 120 cu. ft. per second. Determine the necessary gradient and the total head lost.

90. The Aqua Claudia, shown in Fig. 121, was one of the nine principal aqueducts in use in the First Century, A. D., for supplying Rome with water. The lengths and capacities of these nine aqueducts were as follows:

Name	Date of construction	Length in feet	Length in miles	Discharge per day in cu. ft.	Altitude of springs above sea level in feet	Level in Rome in feet
Aqua Appia....	312 B. C.	53,950	10.2	4,072,500	98	65
Anio Vetus....	272-269	209,000	39.6	9,814,200	918	157
Aqua Marcia...	144-140	299,960	56.8	10,465,800	1043	192
Aqua Tepula...	125	58,200	11.0	993,000	495	199
Aqua Julia.....	33	74,980	14.2	2,691,200	1148	209
Aqua Virgo.....	19	67,900	12.9	5,587,700	79	65
Aqua Absietina.....		107,775	20.4	874,800	685	54
Aqua Claudia...	38-52 A. D.	225,570	42.7	7,390,800	1050	221
Anio Novus....	38-52 A. D.	285,330	54.0	10,572,900	1312	231

The construction of the earliest aqueducts was the simplest, most of them being underground. In the Aqua Appia only 300 ft. were above ground, and in the Anio Vetus only 1100 ft. were above ground. In the Aqua Marcia 7.5 miles were supported on arches; in the Aqua Claudia 10 miles were on arches, and in the Anio Novus 9.5 miles were on arches. The construction of the last shows the greatest engineering skill, as it follows a winding course, at certain points tunnelling through hills and at others crossing ravines 300 ft. deep.

The cross section of the channels (*specus*) varied at different points of the course, that of the largest, the Anio Novus, being 3 to 4 ft. wide and 9 ft. high to the top, which was of pointed shape. The channels were lined with hard cement (*opus signinum*) containing fragments of broken brick. The water was so hard that it was necessary to clean out the calcareous deposits frequently, and for this purpose shafts or openings were constructed at intervals of 240 ft.

Filtering and settling tanks (*piscinæ limariæ*, or "purgatories") were constructed on the line of the aqueduct just outside the city, and within the city the aqueducts ended in huge distributing reservoirs (*Castella*) from which the water was conducted to smaller reservoirs for distribution to the various baths and fountains.

Supposing the population of Rome and suburbs to have then numbered one million, there was a daily water supply of nearly 400 gal. per capita. Modern Rome with a population of half a million has a supply of about 200 gal. per capita. The volume of water may also be compared with that of the Tiber which discharges 342,395,000 gal. per day, whereas in the First Century, A. D., the aqueducts carried not less than 392,422,500 gal. per day, which by the Fourth Century had been increased by additional supplies to 461,628,200 gal. per day.

Assuming that the Aqua Claudia had an average width of 3 ft. with 6 ft. depth of water, and that the grade was uniform and the difference in head lost in friction, calculate from the values tabulated above the velocity of flow and Chezy's constant  $C$  in the formula  $v = C \sqrt{rs}$ .

91. A channel of trapezoidal section with side slopes of two horizontal to one vertical is required to discharge 100 cu. ft. per second with a velocity of flow of 3 ft. per second. Assuming Chezy's constant as 115, compute the required bottom width of channel and its longitudinal slope.

92. A channel of trapezoidal cross section has a bottom width of 25 ft. and side slopes of 1 to 1. If the depth of water is 6 ft. and the longitudinal inclination of the bed is 1 in 5000, find the discharge, assuming the coefficient of roughness,  $n$ , in Kutter's formula to be 0.02.

93. A channel of rectangular section has a bottom width of 20 ft., depth of water 6 ft. and longitudinal slope of 1 in 1000. Calculate the discharge, assuming the coefficient of roughness,  $n$ , in Kutter's formula to be 0.01.

94. A reservoir  $A$  supplies another reservoir  $B$  with 400 cu. ft. of water per second through a ditch of trapezoidal section, with earth banks, 5 miles long. To avoid erosion, the flow in this channel must not exceed 2 ft. per second.



From reservoir *B* the water flows to three other reservoirs, *C*, *D*, *E*. From *B* to *C* the channel is to be rectangular in section and 4 miles long, constructed of unplanned lumber, with a 10-ft. fall and a discharge of 150 cu. ft. per second.

From *B* to *D* the channel is to be 5 miles long, semicircular in section and constructed of concrete, with 12-ft. fall and a discharge of 120 cu. ft. per second.

From *B* to *E* the channel is to be 3 miles long, rectangular in section and constructed of rubble masonry, with 15 ft. fall and a discharge of 130 cu. ft. per second.

Find the proper dimensions for each channel section.

95. The flow through a circular pipe when completely filled is 25 cu. ft. per second at a velocity of 9 ft. per second. How much

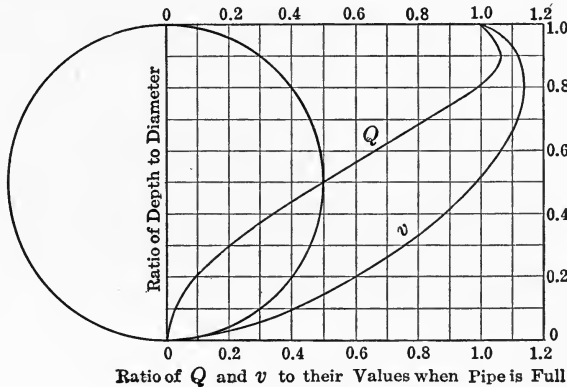

FIG. 122.

would it discharge if filled to 0.8 of its depth, and with what velocity?

*Solution.*—Fig. 122 shows a convenient diagram for solving a problem of this kind graphically.<sup>1</sup> The curve marked *v* (velocity) is plotted from Kutter's simplified formula

$$v = \left( \frac{100 \sqrt{r}}{b + \sqrt{r}} \right) \sqrt{rs}$$

for a value of *b* of 0.35, and the discharge *Q* from the formula  $Q = Av$ , the ordinates to the curves shown in the figure being the

<sup>1</sup> Imhoff. Taschenbuch für Kanalisations Ingenieure.

ratio of the depth of the stream to the diameter of the pipe, and the abscissas the ratios of  $Q$  and  $v$  respectively to their values when the pipe flows full.

To apply the diagram to the problem under consideration, observe that for a depth of  $0.8d$  the abscissa of the discharge curve is unity, and consequently the discharge for this depth is the same as when the pipe is completely filled. The abscissa of the velocity curve corresponding to this depth  $0.8d$  (*i.e.*, with abscissa 0.8) is 1.13, and consequently the velocity at this depth is  $1.13 \times 9 = 10.17$  ft. per second.

Similar diagrams have been prepared by Imhoff for a large variety of standard cross sections and are supplemented by other diagrams or charts which greatly simplify ordinary sewer calculations.

**Problem 96.**—In the Catskill Aqueduct, which forms part of the water supply system of the City of New York, there are four

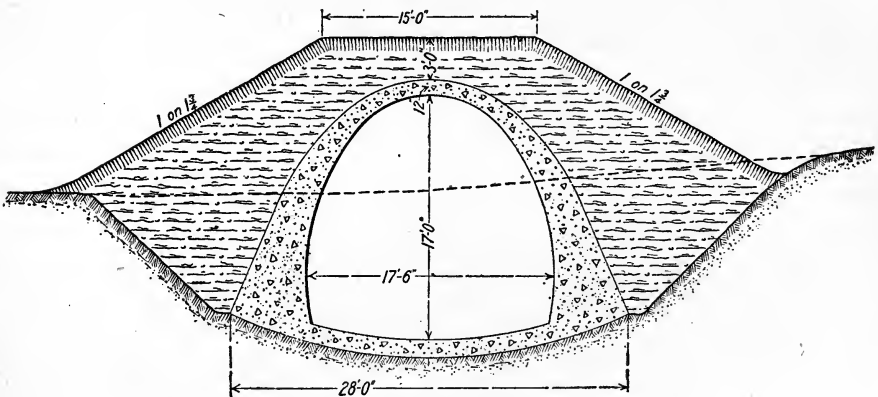

FIG. 123.—Cut and cover conduit, Catskill aqueduct.

distinct types of conduit; the cut-and-cover type, grade tunnel, pressure tunnel, and steel pipe siphon. The cut-and-cover type, shown in section in Fig. 123, is 55 miles in length, and is constructed of concrete and covered with an earth embankment. This is the least expensive type, and is used wherever the elevation and nature of the ground permits.

The hydraulic data for the standard type in open cut is as follows:

s = 0.00021				
Depth of flow in feet	Area of flow in sq. ft.	Wetted perimeter in feet	Hydraulic radius in feet	
17.0	241.0	57.4	4.20	Full, Max. cap.
16.2	237.7	50.8	4.67	
15.3	230.9	47.7	4.84	
14.0	217.6	44.1	4.92	
12.0	192.6	39.4	4.88	
10.0	163.2	35.0	4.65	
8.0	130.7	30.9	4.24	
6.0	97.1	26.8	3.61	
4.0	62.2	22.8	2.72	
2.0	27.0	18.8	1.47	

In the preliminary calculations the relative value of Chezy's coefficient for this type was assumed to be  $C = 125$ . Using this value, calculate the maximum daily discharge.

**Problem 97.**—Where hills or mountains cross the line of the Aqueduct, tunnels are driven through them at the natural elevation of the Aqueduct (Fig. 124). There are 24 of these grade tunnels, aggregating 14 miles. The hydraulic data for the standard type of grade tunnel is as follows:

s = 0.00037				
Depth of flow in feet	Area of flow in sq. ft.	Wetted perimeter in feet	Hydraulic radius in feet	
17.0	198.6	52.2	3.80	Full, Max. cap.
16.25	195.6	46.0	4.25	
15.3	188.5	42.7	4.41	
14.0	175.7	39.3	4.46	
12.0	152.4	35.0	4.35	
10.0	126.8	31.0	4.10	
8.0	100.2	26.9	3.72	
6.0	73.8	22.9	3.22	
4.0	47.6	18.9	2.51	
2.0	21.0	14.9	1.49	

The relative value of Chezy's coefficient for this type was assumed in the preliminary calculations to be  $C = 120$ . Using this value, calculate the maximum daily discharge and the corresponding velocity of flow.

**Problem 98.**—Where the line of the Aqueduct crosses broad and deep valleys and there is suitable rock beneath them, circular

tunnels are driven deep in the rock and lined with concrete (Fig. 125). There are seven of these pressure tunnels, with an

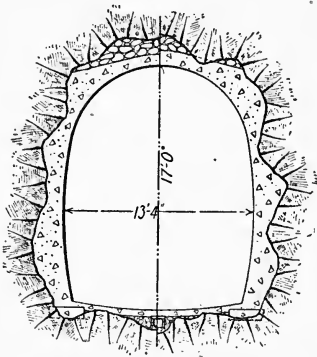

FIG. 124.—Grade tunnel, Catskill aqueduct.

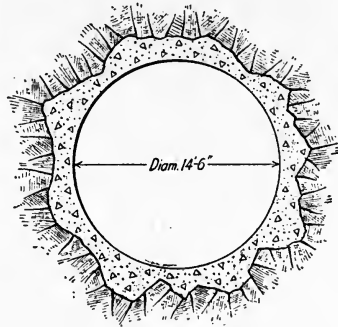

FIG. 125.—Pressure tunnel, Catskill aqueduct.

aggregate length of 17 miles. The hydraulic data for these pressure tunnels is as follows:

Slope	Diameter	Area of waterway	Wetted perimeter	Hydraulic radius
0.00059	14 ft. 6 in.	165.1 sq. ft.	45.55 ft.	3.625 ft.

Assuming the relative value of Chezy's coefficient to be  $C = 120$ , calculate the velocity of flow and the daily discharge.

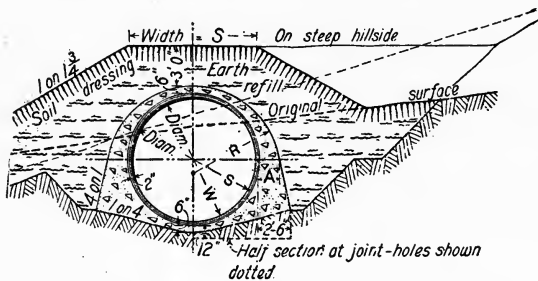

FIG. 126.—Steel pipe siphon, Catskill aqueduct.

**Problem 99.**—In valleys where the rock is not sound, or where for other reasons pressure tunnels are impracticable, steel pipe siphons are used (Fig. 126). These are made of steel plates riveted together, from  $7/16$  to  $3/4$  of an inch in thickness, and

are 9 ft. and 11 ft. in diameter respectively. These pipes are embedded in concrete and covered with an earth embankment, and are lined with 2 in. of cement mortar as a protection to the steel and also for the sake of smoothness. There are 14 of these siphons aggregating 6 miles in length, and three pipes are required for the full capacity of the Aqueduct. Assuming three mortar lined 11-ft. pipes, having a relative coefficient of  $C = 120$  and a slope  $s = 0.00059$ , calculate the velocity of flow through them and the maximum daily discharge.

**Problem 100.**—A broad shallow stream has naturally a depth of 3 ft. and a longitudinal slope of 5 ft. per mile. If a dam 8 ft. high is erected across the stream, determine the rise in level one mile up stream assuming the value of the constant  $C$  in Chezy's formula as 75.

SECTION III  
HYDRODYNAMICS

29. PRESSURE OF JET AGAINST STATIONARY DEFLECTING SURFACE

**Normal Impact on Plane Surface.**—When a jet of water strikes a stationary flat plate or plane surface at right angles, the water spreads out equally in all directions and flows along this plane surface, as indicated in Fig. 127. The momentum

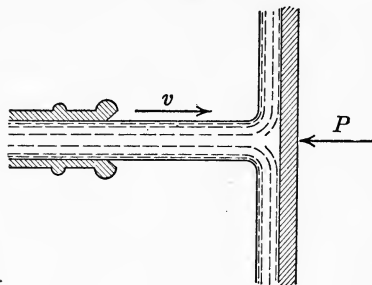

FIG. 127.

of the water after striking the surface is equal to the sum of the momenta of its separate particles, but since these flow off in opposite directions their algebraic sum is zero. Consequently the entire momentum of a jet is destroyed by normal impact against a stationary plane surface.

To find the pressure,  $P$ , exerted by the jet on the surface, let  $A$  denote the cross section of the jet and  $v$  its velocity. Then the mass of water flowing per unit of time is

$$M = \frac{\gamma Av}{g},$$

and, consequently, from the principle of impulse and momentum,

$$\int P dt = Mv = \frac{\gamma Av^2}{g}.$$

For uniform or steady flow,  $P$  is constant, and if  $M$  denotes the quantity flowing per unit of time, then  $t$  is unity. In this case the above expression for the hydrodynamic pressure  $P$  of the jet on the surface becomes

$$P = \frac{\gamma Av^2}{g}. \tag{77}$$

If  $h$  denotes the velocity head, then  $h = \frac{v^2}{2g}$ , and Eq. (77) may be written

$$P = 2\gamma Ah. \quad (78)$$

**Relation of Static to Dynamic Pressure.**—If the orifice is closed by a cover or stopper, then the *hydrostatic* pressure  $P'$  on this cover is approximately equal to the weight of a column of water of height  $h$  and cross section  $A$ ; and consequently

$$P' = \gamma Ah. \quad (79)$$

Comparing Eq. (78) and (79), it is apparent that the normal hydrodynamic pressure of a jet on an external plane surface is twice as great as the hydrostatic pressure on this surface would be if it was shoved up against the opening so as to entirely close the orifice.

In deriving this relation, the coefficient of efflux is assumed to be unity; that is, the area  $A$  of the jet is assumed to be the same as that of the orifice, and the velocity  $v$  to be the full value corresponding to the head  $h$ . Since the coefficient is actually less than unity, the hydrodynamic pressure never attains the value given by Eq. (78). For instance, in the case of flow from a standard orifice, if  $A$  denotes the area of the orifice and  $a$  the cross section of the jet, then from Arts. 8 and 9

$$a = 0.62A, \text{ and } v = 0.97 \sqrt{2gh}.$$

Therefore the expression for  $P$  becomes

$$P = \frac{\gamma av^2}{g} = 2\gamma(0.62A)(0.97^2h) = 1.19\gamma Ah$$

instead of  $2\gamma Ah$ , as given by Eq. (78). Note, however, that this apparently large discrepancy is due chiefly to the fact that the area  $A$  in Eq. (78) denotes the cross section of the jet, whereas in Eq. (79) it denotes the area of the orifice. If the area  $A$  in both expressions denotes the cross section of the jet, Eq. (78) is practically true, and the hydrodynamic pressure is approximately twice the hydrostatic pressure on an equal area.

**Oblique Impact on Plane Surface.**—If a jet strikes a stationary plane surface obliquely, at an angle  $\alpha$  (Fig. 128), the axial velocity  $v$  of the jet may be resolved into two components,  $v \sin \alpha$  normal to the surface, and  $v \cos \alpha$  tangential to the surface. If the surface is perfectly smooth, the water flowing along the surface experiences no resistance to motion, and the pressure,  $P$ , exerted on the surface is that corresponding to the normal velocity

component  $v' = v \sin \alpha$ . The area to be considered, however, is not a right section,  $A$ , of the jet, but a section  $A'$  normal to

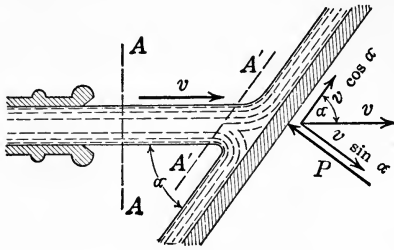

FIG. 128.

the component  $v \sin \alpha$ , as indicated in Fig. 128. The total pressure,  $P$ , exerted on the surface, is then

$$P = \frac{\gamma A' v^2}{g}$$

or, since  $v' = v \sin \alpha$  and  $A' = \frac{A}{\sin \alpha}$ , this may be written in

the form

$$P = \frac{\gamma A v^2}{g} \sin \alpha. \tag{80}$$

If  $\alpha = 90^\circ$ , this reduces to Eq. (77).

**Axial Impact on Surface of Revolution.**—If the surface on which the jet impinges is a surface of revolution, coaxial with the jet (Fig. 129), then in this case also the particles spread out

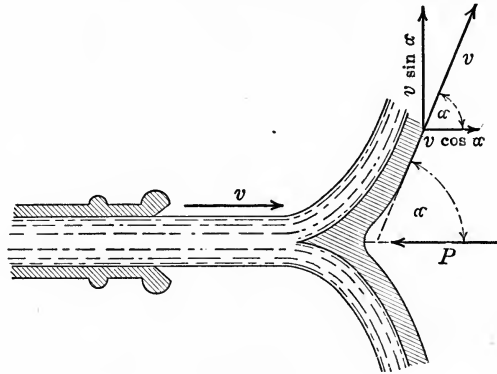

FIG. 129.

equally in all directions, and consequently the sum of the momenta of the particles in the direction perpendicular to the axis of the jet is zero. The velocity of any particle in a direction parallel to the axis of the jet, however, becomes  $v \cos \alpha$ , where  $\alpha$  denotes the angle which the final direction taken by the particles makes with their initial direction, as indicated in Fig. 129. The total initial momentum is then

$$Mv = \frac{\gamma A v^2}{g},$$



and the total final momentum is

$$Mv \cos \alpha = \frac{\gamma Av^2}{g} \cos \alpha.$$

Therefore, equating the impulse to the change in momentum, we obtain the relation

$$P = \frac{\gamma Av^2}{g} (1 - \cos \alpha). \quad (81)$$

For a jet impinging normally on a plane surface,  $\alpha = 90^\circ$ , and this expression reduces to Eq. (77).

**Complete Reversal of Jet.**—If  $\alpha$  is greater than  $90^\circ$ , then  $\cos \alpha$  becomes negative and the pressure  $P$  is correspondingly

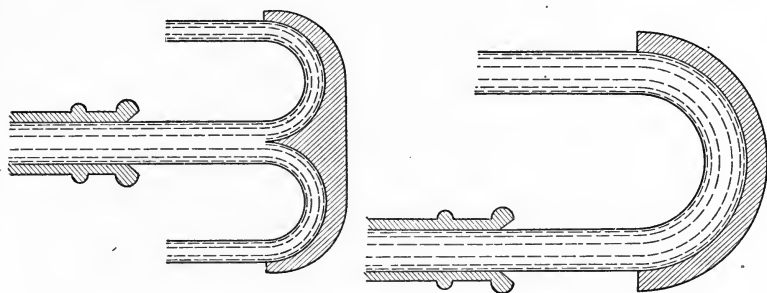

FIG. 130.

increased. For example, if the direction of flow is completely reversed, as shown in Fig. 130, then  $\alpha = 180^\circ$ ,  $\cos \alpha = -1$ , and hence

$$P = \frac{2\gamma Av^2}{g}. \quad (82)$$

The hydrodynamic pressure in this case is therefore twice as great as the normal pressure on a flat surface, and four times as great as the hydrostatic pressure on a cover over an orifice of the same area as the cross section of the jet.

**Deflection of Jet.**—When a jet is deflected in an oblique direction, the final velocity  $v$  may be resolved into components  $v \cos \alpha$  and  $v \sin \alpha$ , as indicated in Fig. 131. The component of the final momentum *parallel* to the initial direction of the jet is then

$$Mv(1 - \cos \alpha) = \frac{\gamma Av^2}{g} (1 - \cos \alpha),$$

and the horizontal component,  $H$ , exerted in this direction is

$$\mathbf{H} = \frac{\gamma A v^2}{g} (1 - \cos \alpha). \quad (83)$$

Similarly, the component of the final momentum *perpendicular* to the initial direction of the jet is

$$M v \sin \alpha = \frac{\gamma A v^2}{g} \sin \alpha,$$

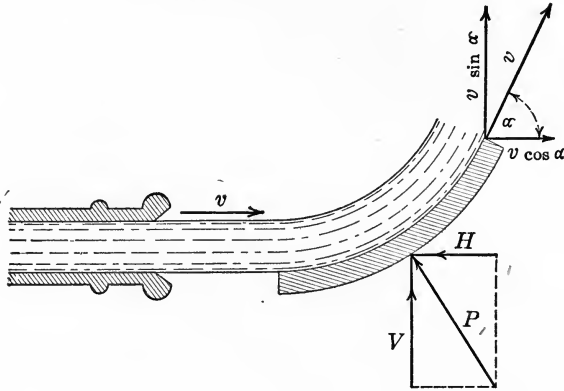

FIG. 131.

and the vertical component,  $V$ , exerted in this direction is

$$\mathbf{V} = \frac{\gamma A v^2}{g} \sin \alpha. \quad (84)$$

The total pressure of the jet on the deflecting surface, or reaction of the surface on the jet, is, then,

$$P = \sqrt{H^2 + V^2} = \frac{\gamma A v^2}{g} \sqrt{(1 - \cos \alpha)^2 + \sin^2 \alpha}$$

which simplifies into

$$\mathbf{P} = \frac{\gamma A v^2}{g} \sqrt{2(1 - \cos \alpha)}. \quad (85)$$

A more convenient expression for  $P$  may be obtained by using the trigonometric relation  $\sqrt{\frac{1 - \cos \alpha}{2}} = \sin \frac{1}{2} \alpha$ , by means of which Eq. (85) may be written in the form

$$\mathbf{P} = \frac{2\gamma A v^2}{g} \sin \frac{\alpha}{2}. \quad (86)$$

**Dynamic Pressure in Pipe Bends and Elbows.**—When a bend or elbow occurs in a pipe through which water is flowing, the change in direction of flow produces a thrust in the elbow, as in the case of the deflection of a jet by a curved vane, considered in the preceding article. From Eq. (85) and (86), the amount of this thrust  $P$  is

$$P = \frac{\gamma A v^2}{g} \sqrt{2(1 - \cos \alpha)} = \frac{2\gamma A v^2}{g} \sin \frac{\alpha}{2},$$

and the direction of the thrust evidently bisects the angle  $\alpha$ , as indicated in Fig. 132.

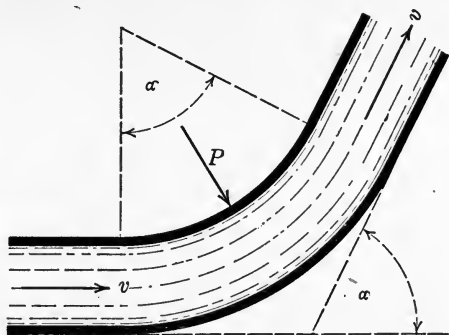

FIG. 132.

In the case of jointed pipe lines if the angle of deflection is large or the velocity of flow considerable, this thrust may be sufficient to disjoint the pipe unless provision is made for taking up the thrust by some form of anchorage, as, for example, by filling in with concrete on the outside of the elbow.

### 30. PRESSURE EXERTED BY JET ON MOVING VANE

**Relative Velocity of Jet and Vane.**—In the preceding article it was assumed that the surface on which the jet impinged was fixed or stationary. The results obtained, however, remain valid if the surface moves parallel to the jet in the same or opposite direction, provided the velocity,  $v$ , refers to the *relative velocity* between jet and surface. Thus if the surface moves in an opposite direction to the jet with a velocity  $v'$ , the relative velocity of jet and surface is  $v + v'$  and the pressure is correspondingly increased, whereas if they move in the same direction, their relative velocity is  $v - v'$ , and the pressure is diminished.

**Work Done on Moving Vane.**—Consider, for example, the case of a jet striking a deflecting surface and assume first that this surface moves in the same direction as the jet with velocity  $v'$  (Fig. 133). Since the surface, or vane, is in motion, the mass of water,  $M'$ , reaching the vane per second is not the same

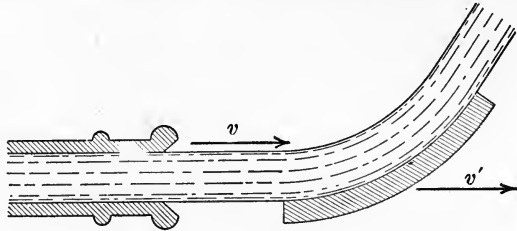

FIG. 133.

as the mass of water,  $M$ , passing a given cross section of the jet per second. That is, the mass,  $M$ , issuing from the jet per second is

$$M = \frac{\gamma A v}{g},$$

whereas the mass,  $M'$ , flowing over the vane per second is

$$M' = \frac{\gamma A (v - v')}{g}.$$

Therefore the components of the force acting on the vane, given by Eq. (83) and (84), become in this case

$$\left. \begin{aligned} H &= M'(v - v')(1 - \cos \alpha) = \frac{\gamma A}{g}(v - v')^2(1 - \cos \alpha), \\ V &= M'(v - v') \sin \alpha = \frac{\gamma A}{g}(v - v')^2 \sin \alpha. \end{aligned} \right\} (87)$$

Since the motion of the vane is assumed to be in the direction of the component  $H$ , the component  $V$ , perpendicular to this direction, does no work. The total work,  $W$ , done on the vane by the jet is therefore

$$W = H v' = \frac{\gamma A v' (v - v')^2}{g} (1 - \cos \alpha). \quad (88)$$

**Speed at which Work Becomes a Maximum.**—The condition that the work done shall be a maximum is

$$\frac{dW}{dv'} = 0 = \frac{\gamma A}{g} (1 - \cos \alpha) [(v - v')^2 - 2v'(v - v')],$$

whence

$$v' = \frac{v}{3}. \quad (89)$$

Substituting this value of  $v'$  in Eq. (88), the maximum amount of work that can be realized under the given conditions is found to be

$$W_{max} = \frac{\gamma A \frac{v}{3}}{g} \left( v - \frac{v}{3} \right)^2 (1 - \cos \alpha) = \frac{4\gamma A v^3}{27g} (1 - \cos \alpha).$$

**Maximum Efficiency for Single Vane.**—The efficiency of a motor or machine is defined in general as

$$\text{Efficiency} = \frac{\text{Useful work}}{\text{Total energy available}}. \quad (90)$$

Since, in the present case, the total kinetic energy of the jet is

$$K.E. = \frac{1}{2} M v^2 = \frac{\gamma A v^3}{2g},$$

the efficiency,  $E$ , becomes

$$E = \frac{\frac{4\gamma A v^3}{27g} (1 - \cos \alpha)}{\frac{\gamma A v^3}{2g}} = \frac{8}{27} (1 - \cos \alpha).$$

The maximum efficiency occurs when  $\alpha = 180^\circ$ , in which case

$$E_{max} = \frac{16}{27} = 59.2 \text{ per cent.} \quad (91)$$

**Maximum Efficiency for Continuous Succession of Vanes.**—

If there is a series of vanes following each other in succession so that each receives only a portion of the water, allowing this portion to expend its energy completely on this vane before leaving it, then the mass  $M'$  in Eq. (87) is replaced by  $M$ , and the component  $H$  becomes

$$H = M(v - v')(1 - \cos \alpha) = \frac{\gamma A v(v - v')}{g} (1 - \cos \alpha).$$

The work done on the series of vanes is therefore

$$W = H v' = \frac{\gamma A v v' (v - v')}{g} (1 - \cos \alpha). \quad (92)$$

The condition for a maximum in this case is

$$\frac{dW}{dv'} = 0 = \frac{\gamma A v}{g} (1 - \cos \alpha) [(v - v') - v'],$$

whence

$$v' = \frac{v}{2}. \quad (93)$$

Substituting this value of  $v'$  in Eq. (92), the maximum work which can be realized from a series of vanes moving parallel to the jet is

$$W_{max} = \frac{\gamma A v^2}{g} \left( v - \frac{v}{2} \right) (1 - \cos \alpha) = \frac{\gamma A v^3}{4g} (1 - \cos \alpha).$$

Hence the efficiency in this case is

$$E = \frac{\frac{\gamma A v^3}{4g} (1 - \cos \alpha)}{\frac{\gamma A v^3}{2g}} = \frac{1}{2} (1 - \cos \alpha).$$

The maximum efficiency therefore occurs when  $\alpha = 180^\circ$ , its value being

$$E_{max} = \frac{1}{2} (2) = 100 \text{ per cent.} \quad (94)$$

The actual efficiency of course can never reach this upper limit, as the conditions assumed are ideal, and no account is taken of frictional and other losses.

**Impulse Wheel; Direction of Vanes at Entrance and Exit.**— In general, it is not practicable to arrange a series of vanes so

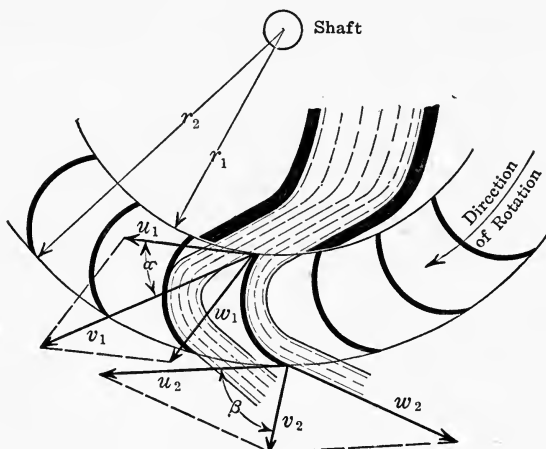

FIG. 134.

as to move continuously in a direction parallel to the jet. As usually constructed, the vanes are attached to the circumference of a wheel revolving about a fixed axis (Fig. 134). Let  $\omega$  denote the angular velocity of the wheel about its axis, and  $r_1, r_2$  the radii

of the inner and outer edges of the vanes. Then the tangential or linear velocities at these points, say  $u_1$  and  $u_2$ , are

$$u_1 = r_1\omega; u_2 = r_2\omega.$$

Now let  $v_1$  denote the absolute velocity of the jet at entrance to the vane, and  $v_2$  its absolute velocity at exit. Then by forming a parallelogram of velocities on  $u_1$  and  $v_1$  as sides, the relative velocity,  $w_1$ , between jet and vane at entrance is determined, as indicated in Fig. 134. Similarly, the parallelogram on  $u_2, w_2$  as sides determines the absolute velocity,  $v_2$ , at exit. In order that the water may glide on the vane without shock, the tip of the vane at entrance must coincide in direction with the vector  $w_1$ .

**Work Absorbed by Impulse Wheel.**—Let  $M$  denote the mass of water passing over the vane per second. At entrance the velocity of this mass in the direction of motion (*i.e.*, its tangential velocity) is  $v_1 \cos \alpha$ , and at exit is  $v_2 \cos \beta$ , where  $\alpha$  and  $\beta$  are the angles indicated in Fig. 134. The linear momentum of the mass  $M$  at entrance is then  $Mv_1 \cos \alpha$ , and its angular momentum is  $Mv_1r_1 \cos \alpha$ . Similarly, its linear momentum at exit is  $Mv_2 \cos \beta$  and its angular momentum is  $Mv_2r_2 \cos \beta$ . The total change in angular momentum per second, that is, the amount given up by the water or imparted to the wheel, is then

$$Mv_1r_1 \cos \alpha - Mv_2r_2 \cos \beta.$$

For a continuous succession of vanes, as in the case of an ordinary impulse wheel, the mass  $M$  is the total amount of water supplied by the jet per second. Hence, if  $T$  denotes the total torque exerted on the wheel, by the principle of angular impulse and momentum, remembering that  $M$  is the mass of water flowing per unit of time, and consequently that the time is unity,

$$T = M(v_1r_1 \cos \alpha - v_2r_2 \cos \beta). \tag{95}$$

The total work imparted to the wheel is

$$W = T\omega,$$

or, since  $M = \frac{\gamma Av_1}{g}$ ,  $u_1 = r_1\omega$ ,  $u_2 = r_2\omega$ , the expression for the work becomes

$$W = T\omega = \frac{\gamma Av_1}{g} (u_1v_1 \cos \alpha - u_2v_2 \cos \beta). \tag{96}$$

These relations will be applied in Art. 34 to calculating the power and efficiency of certain types of impulse wheels.

## 31. REACTION OF A JET

**Effect of Issuing Jet on Equilibrium of Tank.**—Consider a closed tank containing water or other liquid, and having an orifice in one side closed by a cover. When the cover is removed the equilibrium of water and tank will be destroyed. At the instant of removal this is due to the disappearance of the pressure previously exerted on the cover considered as part of the tank. After the jet has formed and a steady flow has been set up, assuming that the depth of water is maintained constant by supplying an amount equal to that flowing out, as indicated in Fig. 135, the pressure within the fluid and on the walls of the tank will not regain its original static value, since, in accordance with Bernoulli's theorem, an increase in velocity must be accompanied by a corresponding decrease in pressure.

**Energy of Flow Absorbed by Work on Tank.**—To calculate the effect of the flow on the equilibrium of the tank, suppose that the

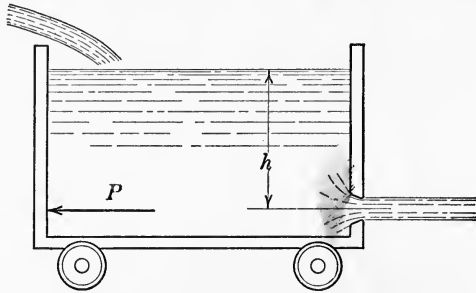

FIG. 135.

tank is moved in the direction opposite to that of the jet and with the same velocity,  $v$ , as that of the jet. Then the relative velocity of the jet with respect to the tank is still  $v$ , but the absolute velocity of the jet is zero and consequently its kinetic energy is also zero. If  $h$  denotes the head of water on the orifice (Fig. 135) and  $Q$  the quantity of water flowing per second, then its loss in potential energy per second is  $\gamma Qh$ . Moreover, while this volume of water  $Q$  moved with the tank, it had a velocity  $v$ , and therefore possessed kinetic energy of amount  $\frac{\gamma Qv^2}{2g}$ . The total energy given up by the water in flowing from the tank is then

$$\gamma Qh + \frac{\gamma Qv^2}{2g};$$



or, since  $h = \frac{v^2}{2g}$  approximately, these terms are equal, and the total energy lost by the water becomes

$$\text{Energy given up} = \frac{\gamma Q v^2}{g}.$$

Now let  $P$  denote the reaction of the jet, that is, the resultant of all the pressure exerted on the tank by the water except that due to its weight. Then, since the distance traversed by the force  $P$  in a unit of time is the velocity  $v$  of the tank, by equating the work done by  $P$  to the energy given up by the water, we have

$$Pv = \frac{\gamma Q v^2}{g},$$

whence

$$P = \frac{\gamma Q v}{g} = \frac{\gamma A v^2}{g} = 2\gamma A h.$$

The reaction  $P$  is therefore twice the hydrostatic pressure due to the head  $h$ .

This is also apparent from the results of Art. 27, since the pressure of a jet on a fixed surface close to the orifice must be equal to its reaction on the vessel from which the jet issues. The actual reaction of the jet is of course somewhat less than its theoretical value, as given by the relation  $P = 2\gamma A h$ , since there are various losses, due to internal friction, etc.

**Principle of Reaction Turbine.**—In order for the tank to retain its uniform velocity,  $v$ , a resistance of amount  $P$  must constantly be overcome, for if the resistance is less than this amount the motion will be accelerated. It is apparent, therefore, that by a proper choice of the velocity,  $v$ , of the tank it is possible to utilize almost the entire energy of the jet in overcoming a resistance coupled up with the tank. This is the principle on which the reaction turbine is based, as explained in Art. 35.

It should be noted that if the water flowing out is continually replaced from above, half of the available energy must be used in giving the supply water the same velocity as the tank. The useful work is therefore reduced to one-half the previous amount, and the available energy is only that due to the velocity head  $h$ .

**Barker's Mill.**—The simplest practical application of the reaction of a jet is the apparatus known as Barker's mill (Fig. 136). In this apparatus water flows from a tank into a hollow vertical arm, or spindle, pivoted at the lower end, and from this into a

horizontal tubular arm, having two orifices near the ends on opposite sides. The jets issue from these orifices, and their reactions cause the horizontal arm to rotate, driving the central spindle from which the power is taken off by a belt and pulley.

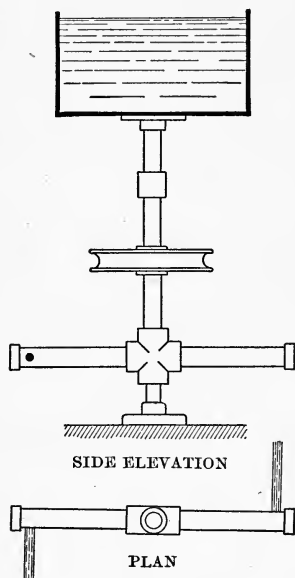

FIG. 136.

The steam turbine invented by Hero of Alexandria in the first century B. C., is an almost identical arrangement, the motive power in this case being due to the reaction of a jet of steam instead of a jet of water.

### 32. TYPES OF HYDRAULIC MOTORS

**Current Wheels.**—There are three general types of hydraulic motors, namely

1. Current and gravity wheels,
2. Impulse wheels and turbines,
3. Reaction turbines.

The current wheel is the oldest type of prime mover, and in its primitive form consisted of a large vertical wheel, with a set of paddles or

buckets attached to its circumference, and so placed in a running stream that the current acting on the lower, or immersed, portion produced revolution of the wheel. A later improvement consisted in placing the wheel at the foot of a water fall and conducting the water by a flume to the top of the wheel, the action of the water in this case being due almost entirely to its weight (Art. 33).

**Impulse Wheels.**—The impulse wheel, as its name indicates, is designed to utilize the impulsive force exerted by a jet moving with a high velocity and striking the wheel tangentially. The wheel, or runner, in this case carries a series of curved buckets or vanes which discharge into the atmosphere. A feature of this type is that the runner rotates at a high velocity and can therefore be made of comparatively small diameter. The two principal types of impulse wheel are the Girard impulse turbine, which originated in Europe, and the Pelton wheel, which was developed in the United States (Art. 34).

**Reaction Turbines.**—The reaction turbine depends chiefly on the reaction exerted by a jet on the vessel from which it flows, which in this case is the passage between the vanes on the runner. In an impulse wheel the energy of the water as it enters the wheel is entirely kinetic, and as there is free circulation of air between the vanes and they discharge into the atmosphere, the velocity of the water is that due to the actual head. In a reaction turbine the energy of the water as it enters the wheel is partly kinetic and partly pressure energy, and as the water completely fills the passages between the vanes, its velocity at entrance may be either greater or less than that due to the static head at that point. A feature of the reaction turbine is that it will operate when completely submerged.

**Classification of Reaction Turbines.**—Reaction turbines are subdivided into four classes, according to the direction in which the water flows through the wheel. These are

- (1) Radial outward flow turbines,
- (2) Radial inward flow turbines,
- (3) Parallel or axial flow turbines,
- (4) Mixed flow turbines, the direction of flow being partly radial and partly axial, changing from one to the other in passing over the vanes (Art. 35).

**Classification of Hydraulic Motors.**—The following tabulated classification is useful as a basis for the description of the various types of hydraulic motors given in Arts. 33, 34 and 35.

<p><i>Current and Gravity Wheels:</i> Utilizes impact of current or weight of the water.</p>	}	<p>Current wheel, Undershot wheel (Poncelet), Breast wheel, Overshot wheel.</p>
<p><i>Impulse Wheels and Turbines:</i> Utilizes kinetic energy of jet at high velocity. Suitable for limited amount of water under high head. Ordinarily used for heads from 300 ft. to 3000 ft.</p>	}	<p>Girard turbine (European), Pelton wheel (American).</p>
<p><i>Reaction Turbines:</i> Utilizes both kinetic and pressure energy of water. Suitable for large quantities of water under low or medium head. Ordinarily used for heads from 5 to 500 ft.</p>	}	<p>Radial inward flow (Francis type), Radial outward flow (Fourneyron type), Parallel or axial flow (Jonval type), Mixed flow (American type).</p>

## 33. CURRENT AND GRAVITY WHEELS

**Current Wheels.**—The vertical current wheel, mentioned in Art. 32, was the earliest type of hydraulic motor, dating from prehistoric times, although they are still in use in China and Syria.

**Undershot Wheels.**—The first improvement consisted in confining the water in a sluice and delivering it directly on the vanes. This type was known as the *Undershot wheel*, and was in common use until about the year 1800 A. D. (Fig. 137). Flat radial vanes were used with this type, for which the maximum theoretical efficiency was 50 per cent., the velocity of the vanes to realize this efficiency being one-half the velocity of the stream, as explained in Art. 29. The actual efficiency of such wheels was much lower, being only from 20 to 30 per cent.

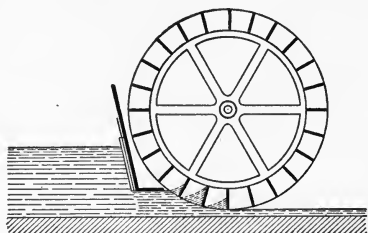

FIG. 137.

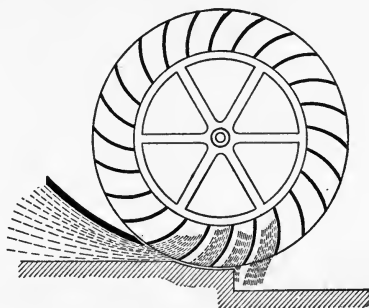

FIG. 138.

**Poncelet Wheels.**—Undershot wheels were greatly improved by Poncelet who curved the vanes, so that the water entered without shock and was discharged in a nearly vertical direction (Fig. 138). The water thus exerted an impulse on the vanes during the entire time it remained in the wheel, thereby raising the actual efficiency to about 60 per cent. Undershot wheels of the Poncelet type are adapted to low falls, not exceeding 7 ft. in height.

**Breast Wheels.**—A modification of the undershot wheel is the *Breast wheel*, the water being delivered higher up than for an ordinary undershot wheel, and retained in the buckets during the descent by means of a *breast*, or casing, which fits the wheel as closely as practicable (Fig. 139). Wheels of this type are known as *high breast*, *breast*, and *low breast* according as the water is delivered to the wheel above, at, or below the level of the center

of the wheel. The high breast wheel operates almost entirely by gravity, that is, by the unbalanced weight of the water in the buckets, its efficiency being from 70 to 80 per cent. Breast and low breast wheels operate partly by gravity and partly by impulse, the efficiency varying from about 50 per cent. for small wheels to 80 per cent. for large wheels. This type was in use until about 1850.

**Overshot Wheels.**—A more recent type is the *Overshot wheel*, the characteristic of this type being that the water is delivered at the top of the wheel by a sluice, as indicated in Fig. 140. For

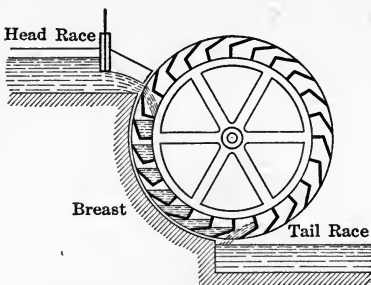

FIG. 139.

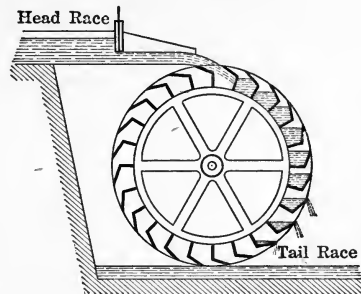

FIG. 140.

maximum efficiency the diameter of the wheel should be nearly equal to the height of the fall, the efficiency for well-designed overshot wheels ranging from 70 to 85 per cent., which is nearly as high as for a modern turbine. An overshot wheel at Troy, N. Y., is 62 ft. in diameter, 22 ft. wide, weighs 230 tons, and develops 550 H.P. Another on the Isle of Man is 72 ft. in diameter and develops 150 H.P.

#### 34. IMPULSE WHEELS AND TURBINES

**Pelton Wheel.**—The intermediate link between the old type of water wheel and the modern impulse wheel was the Hurdy Gurdy, which was introduced into the mining districts of California about 1865. This somewhat resembled the old current wheel, being vertical with flat radial vanes, but differed from it in that it was operated by a jet impinging on the vanes at high velocity. The maximum theoretical efficiency of the Hurdy Gurdy was 50 per cent. (Art. 29), while its actual efficiency varied from 25 to 35 per cent.

The substitution of curved buckets for the flat radial vanes was the great improvement which converted the Hurdy Gurdy into the Pelton wheel. The construction of the bucket is shown in Fig. 141, the jet being divided by the central ridge and each half deflected through nearly  $180^\circ$ . Evidently the angle of deflection must be slightly less than  $180^\circ$ , so that the discharge from one bucket may clear the one following. A later improvement is the Doble bucket, also shown in Fig. 141, each half of

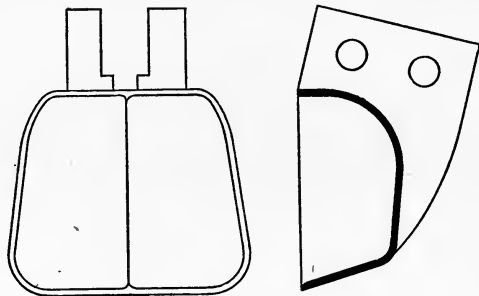

Pelton Bucket

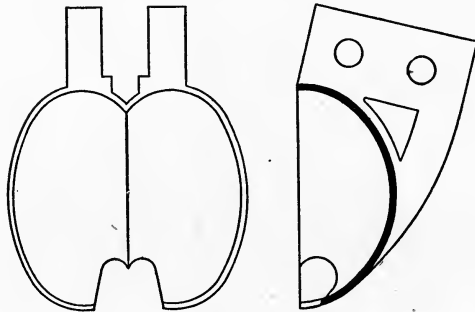

Doble Bucket

FIG. 141.

which is ellipsoidal in form, with part of the outer lip cut away so as to clear the jet when coming into action.

The relation of the jet to the wheel is shown in Fig. 142, the type there shown being arranged with a deflecting nozzle for economic regulation. A more recent type of Pelton wheel is shown in Fig. 143, the features of this type being the Doble buckets and the so-called chain type of attachment of the buckets.

One of the most important features of construction in this type of impulse wheel is the needle valve for regulating the flow. The

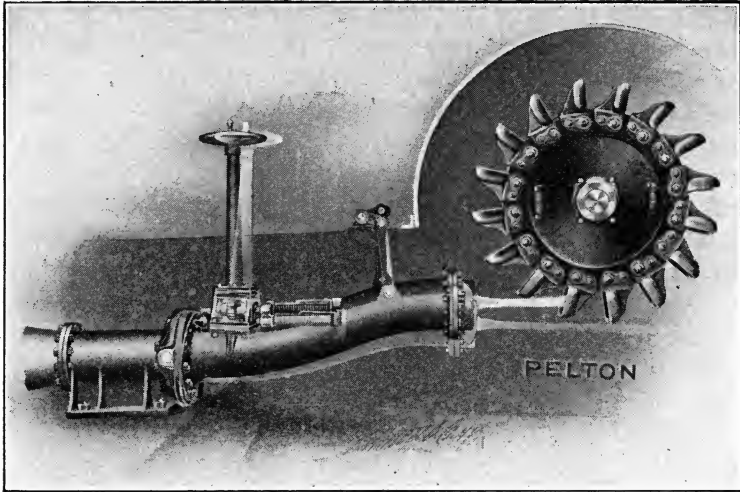

FIG. 142.

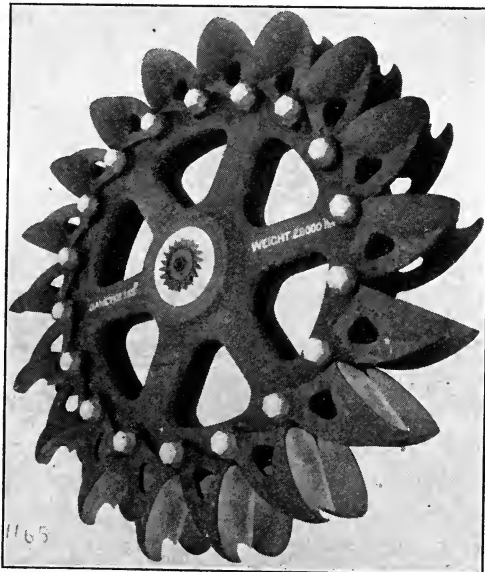

FIG. 143.—Pelton-Doble runner, diameter 153 in., weight 28,000 lbs.

cross section shown in Fig. 144 indicates the location of the needle valve with respect to the nozzle. The methods of operating the valve and of elevating and depressing the nozzle are shown in Fig. 145. This form of nozzle under the high heads ordinarily used gives a very smooth and compact jet, as shown by the instantaneous photograph reproduced in Fig. 146.

**Efficiency of Pelton Wheel.**—If the jet was completely reversed in direction and the speed of the buckets was one-half that of the jet, the theoretical efficiency of the Pelton wheel would be unity, or 100 per cent., as shown by Art. 30, Eq. (94). This is

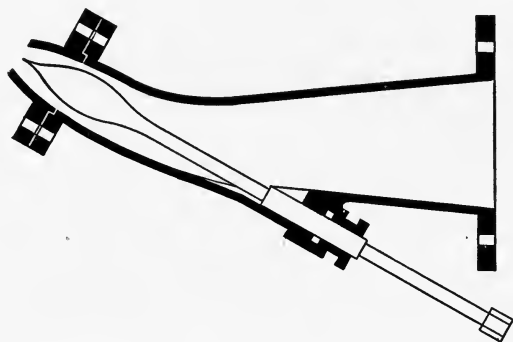

FIG. 144.

also apparent from other considerations; for if the velocity of the jet is  $v$  and that of the buckets is  $\frac{v}{2}$ , then the velocity of the water relative to the lowest bucket is  $v - \frac{v}{2}$ , or  $\frac{v}{2}$  (Fig. 147).

Therefore at exit the water is moving with velocity  $\frac{v}{2}$  relative to the bucket while the bucket itself is moving in the opposite direction with velocity  $\frac{v}{2}$ . Hence the absolute velocity of the

water at exit is  $\frac{v}{2} - \frac{v}{2}$ , or zero, and therefore, since the total kinetic energy of the water has been utilized, the theoretical efficiency of the wheel is unity. As a matter of fact there are hydraulic friction losses to be taken into account and also the direction of flow is not completely reversed. The efficiency of the Pelton wheel has been found in a number of authentic tests to exceed 86 per cent. The actual efficiency in operation de-



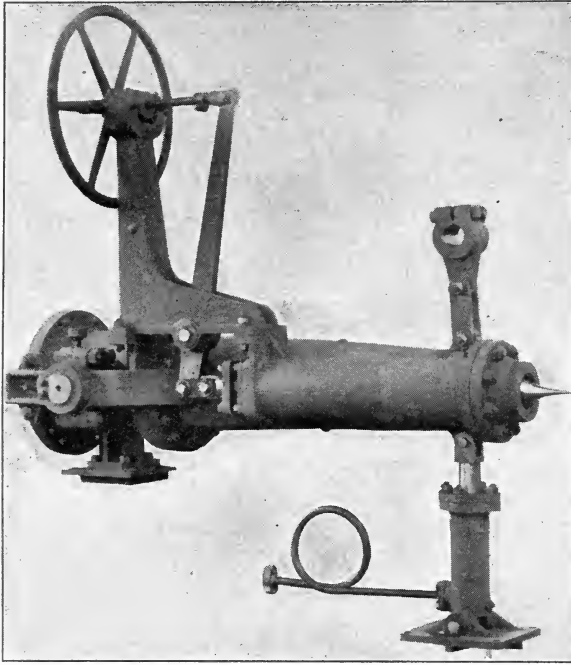

FIG. 145.—Pelton regulating needle nozzle.

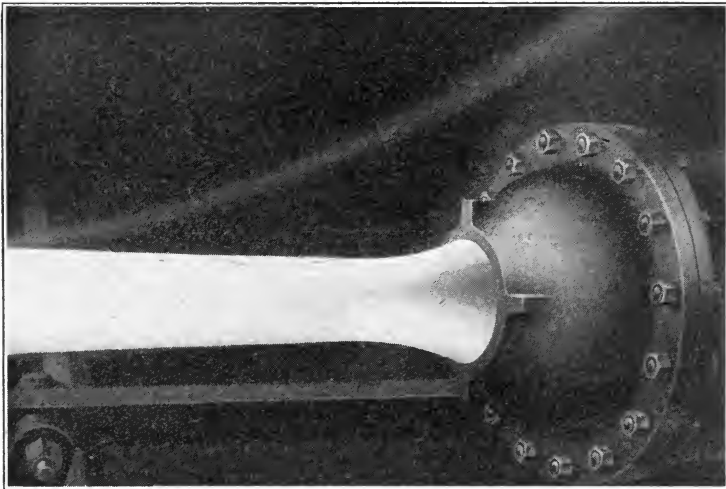

FIG. 146.

pends of course on the particular hydraulic conditions under which the wheel operates. A good idea of what may be expected in practice, however, is given by the following data, obtained from a unit of 4000 KW normal capacity, operating under a head of 1300 feet:

Load in KW	Percentage of normal capacity	Wheel efficiency
5000	125%	81%
4000	100%	83%
3000	75%	82%
2000	50%	70%

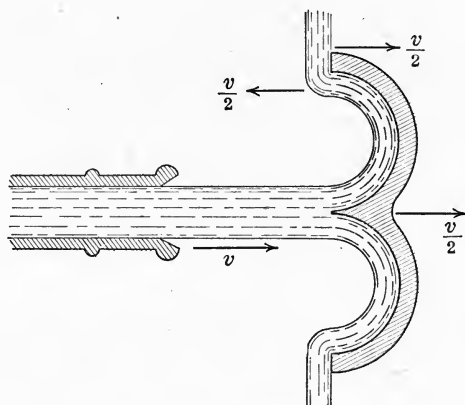

FIG. 147.

Since the Pelton wheel operates by utilizing the kinetic energy of the water, it is best adapted to a small discharge under a high head.

**Girard Impulse Turbine.**—A somewhat different type of impulse wheel has been developed in Europe, known as the Girard impulse turbine. In this type the shaft may be mounted either vertically or horizontally, and the flow may be either radial or axial. The type shown in Fig. 148 is arranged for radial flow, with vertical shaft. The construction is practically the same in all cases, the water entering through a pipe *B*, as shown in Fig. 148, and proceeding through one or more guide passages *C*, which direct the water onto the vanes. The quantity of water admitted to the vanes is regulated by some kind of gate, that indicated in Fig. 148 being a sliding gate operated by a rack and pinion not shown in the figure.

As the vanes are more oblique at exit than at entrance, they are necessarily closer together at exit. To prevent choking, it is therefore necessary to widen the vanes laterally at exit, as shown in elevation in Fig. 148. As the water discharges under atmospheric pressure, ventilating holes are made through the sides of the vanes at the back to allow free admission of air.

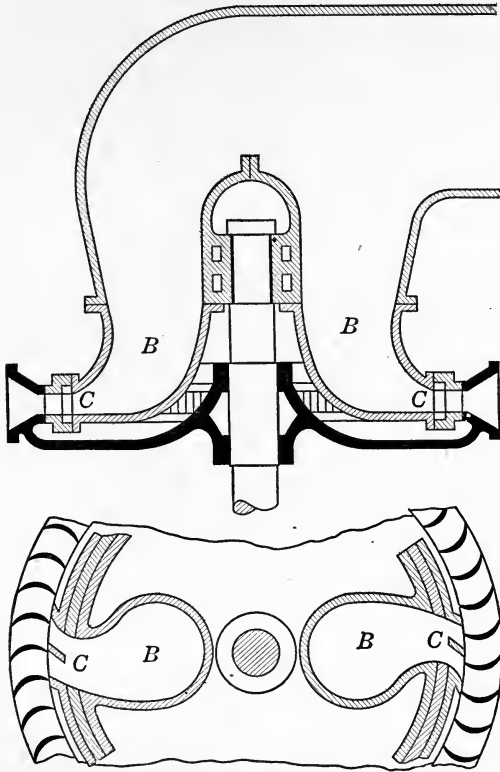

FIG. 148.

**Power and Efficiency of Girard Turbine.**—The power and efficiency of a Girard turbine may easily be calculated from the results of Art. 30. Using the same notation, as indicated on Fig. 134, from Eq. (96), Art. 30, the work done per second on the wheel is given by the relation

$$\text{Work per second} = \frac{\gamma A v_1}{g} (u_1 v_1 \cos \alpha - u_2 v_2 \cos \beta).$$

Since the water is under atmospheric pressure, the absolute velocity  $v_1$  of the water at entrance is calculated from the effective head  $h$  by means of the relation  $v_1 = \sqrt{2gh}$ . From Fig. 149 we have by geometry

$$\begin{aligned}v_1 \cos \alpha &= u_1 + w_1 \cos \theta, \\v_2 \cos \beta &= u_2 - w_2 \cos \phi,\end{aligned}$$

and from the law of cosines

$$\begin{aligned}v_1^2 &= u_1^2 + w_1^2 + 2u_1w_1 \cos \theta. \\v_2^2 &= u_2^2 + w_2^2 - 2u_2w_2 \cos \phi.\end{aligned}$$

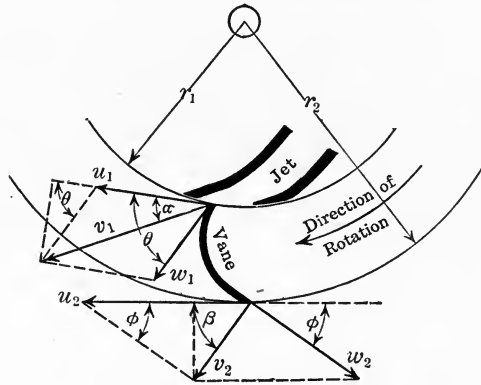

FIG. 149.

Now the total energy imparted to the wheel per second is the difference in kinetic energy at entrance and exit, namely

$$\frac{\gamma A v_1}{2g} (v_1^2 - v_2^2).$$

Therefore, equating this to the expression for the work done per second, as given above, we have

$$\frac{1}{2}(v_1^2 - v_2^2) = u_1 v_1 \cos \alpha - u_2 v_2 \cos \beta.$$

Substituting in this equation the values given above for  $v_1 \cos \alpha$ ,  $v_2 \cos \beta$ ,  $v_1^2$  and  $v_2^2$  and reducing, the result is finally

$$\mathbf{w}_1^2 - \mathbf{w}_2^2 = \mathbf{u}_1^2 - \mathbf{u}_2^2. \quad (97)$$

It is evident that the efficiency will be greater the more nearly the jet is reversed in direction, that is, the smaller  $\phi$  becomes, or what amounts to the same thing, the smaller the absolute

velocity  $v_2$  of the water at exit. However,  $\varphi$  cannot be decreased indefinitely as it is necessary to provide a sufficient area at exit to carry the discharge. For a given value of  $\varphi$ ,  $v_2$  will attain nearly its minimum value when  $u_2 = w_2$ . In this case, however, by Eq. (97) we have  $u_1 = w_1$ , in consequence of which

$$\theta = 2\alpha, \text{ and } \frac{\varphi}{2} = 90^\circ - \beta,$$

and hence

$$v_2 = 2u_2 \sin \frac{\varphi}{2}, \text{ and } u_1 = \frac{v_1}{2 \cos \alpha}.$$

Now the peripheral velocity of the inner and outer ends of the vanes in terms of the angular velocity  $\omega$  of the runner is given by the relations  $u_1 = r_1 \omega$ ,  $u_2 = r_2 \omega$ , whence

$$\frac{u_2}{u_1} = \frac{r_2}{r_1}, \text{ or } u_2 = \frac{u_1 r_2}{r_1}.$$

Substituting this value of  $u_2$  in the expression given above for  $v_2$ , we have

$$v_2 = 2u_2 \sin \frac{\varphi}{2} = \frac{2u_1 r_2 \sin \frac{\varphi}{2}}{r_1} = \frac{v_1 r_2 \sin \frac{\varphi}{2}}{r_1 \cos \alpha}.$$

Consequently if  $Q$  denotes the quantity of water discharged per second, the energy utilized per second is

$$\text{Energy per second} = \frac{\gamma Q}{2g} (v_1^2 - v_2^2) = \frac{\gamma Q v_1^2}{2g} \left( 1 - \frac{r_2^2 \sin^2 \frac{\varphi}{2}}{r_1^2 \cos^2 \alpha} \right).$$

Substituting  $\gamma = 62.4$  and dividing by 550, the expression for the horse power of the wheel is therefore

$$\text{H.P.} = \frac{62.4 Q v_1^2}{2g(550)} \left[ 1 - \left( \frac{r_2}{r_1} \right)^2 \frac{\sin^2 \frac{\varphi}{2}}{\cos^2 \alpha} \right]. \quad (98)$$

Since the total kinetic energy available is  $\frac{\gamma Q v_1^2}{2g}$ , the efficiency,

$E$ , of the wheel, as defined by Eq. (90), Art. 30, is

$$E = 1 - \left( \frac{r_2}{r_1} \right)^2 \frac{\sin^2 \frac{\varphi}{2}}{\cos^2 \alpha}. \quad (99)$$

Since  $E$  is less than unity, it is evident that the maximum theoretical efficiency is always less than 100 per cent., and also that the efficiency is greater the smaller the angles  $\alpha$  and  $\varphi$ .

In practice the angle  $\alpha$  is usually between  $20^\circ$  and  $25^\circ$ ;  $\varphi$  between  $15^\circ$  and  $20^\circ$ ; and the ratio  $\frac{r_2}{r_1}$  between 1.15 and 1.25.

Assuming as average numerical values

$$\alpha = 20^\circ, \quad \varphi = 15^\circ, \quad \frac{r_2}{r_1} = 1.15,$$

and substituting these values in Eq. (99), the theoretical efficiency of the wheel in this case is found to be

$$E = 1 - \left[ 1.15 \frac{\sin 7.5^\circ}{\cos 20^\circ} \right]^2 = 97.5 \text{ per cent. approximately.}$$

This efficiency is, of course, merely ideal as it takes no account of hydraulic friction losses.

The Girard type of impulse turbine was formerly manufactured in this country by the Stilwell-Bierce and Smith-Vaile Co. (now the Platt Iron Works Co., of Dayton, Ohio) under the trade name of the "Victor High Pressure Turbine." In a test of a 45 inch-wheel of this type installed in the power plant of the Quebec Railway Light and Power Co., Montmorency Falls, Quebec, with a rated capacity of 1000 horse power under a head of 195 feet at a speed of 286 r.p.m., a maximum efficiency of 78.38 per cent. was attained.

In another test of a 25-inch Victor wheel installed in the Napanoch Power Station of the Honk Falls Power Co., Ellenville, N. Y., with a rated capacity of 500 horse power under 145 feet head at a speed of 480 r.p.m., a maximum efficiency of 84.2 per cent. was attained.

The average efficiency of Victor wheels in plants installed is said by the manufacturers to vary from 70 to 80 per cent., depending on the design of unit.

In this type of unit, no draft tube is used and consequently that portion of the head from the center line of the wheel to the level of the tail race is lost. Various attempts have been made, both with this and other types of impulse wheel, to regain at least part of this lost head by means of an automatically regulated draft tube, designed to keep the water at a certain fixed level beneath the runner, but this feature has never proved successful in operation.

## 35. REACTION TURBINES

**Historical Development.**—In Art. 29 it was shown that a jet flowing from a vessel or tank exerted a pressure or reaction on the vessel from which it flows. A simple application of this principle was shown in Barker's mill, Fig. 136, in which the reactions of

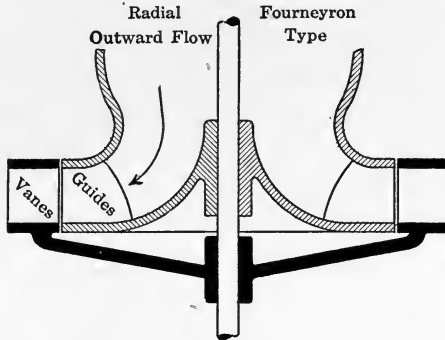

FIG. 150.

two jets caused a horizontal arm to revolve. Later this device was improved by curving the arms so that the jets issued directly from the ends of the arms instead of from orifices in the side, and in this form it was known as the Scotch mill. Subsequently the

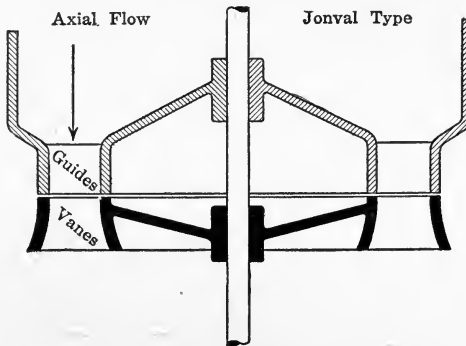

FIG. 151.

number of arms was increased and the openings enlarged, until it finally developed into a complete wheel.

In 1826 a French engineer, Fourneyron, placed stationary guide vanes in the center to direct the water onto the runner, or wheel, the result being the first reaction turbine, now known as the

Fourneyron or outward flow type (Fig. 150). This type was introduced into the United States in 1843.

A later modification of design resulted in the axial or parallel flow turbine, known as the Jonval type, which was also of European origin, and was introduced into the United States about 1850 (Fig. 151).

A crude form of inward flow turbine was built in the United States as early as 1838. Subsequently the design was greatly improved by the noted American hydraulic engineer, J. B. Francis, and it has since been known as the Francis type (Fig. 152).

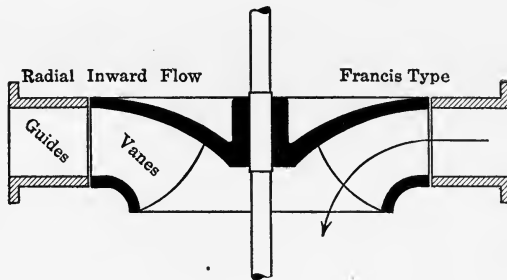

FIG. 152.

Fig. 153 shows a runner of the Francis type used in the plant of the Ontario Power Co. at Niagara Falls. These are double central discharge, or balanced twin turbines, designed to deliver 13,400 H.P. per unit, under 180 ft. head. The runners are of bronze, 82-3/4 in. in diameter; the shafts 24 in. maximum diameter; and the housings of reinforced steel plate 16 ft. in diameter, spiral in elevation and rectangular in plan, as shown in sectional detail in Fig. 154. A cross section of the power house in which these turbines are installed is shown in Fig. 155.

**Mixed Flow, or American, Type.**—The mixed flow turbine, or American type, is a modification of the Francis turbine resulting from a demand for higher speed and power under low heads. Higher speed could only be obtained by using runners of smaller diameter, which meant less power if the design was unaltered in other respects. To increase the capacity of a runner of given diameter the width of the runner was increased, fewer vanes were used, and they were extended further toward the center. As this decreased the discharge area, the vanes were curved so as to discharge the water axially (Fig. 156). In a standard turbine



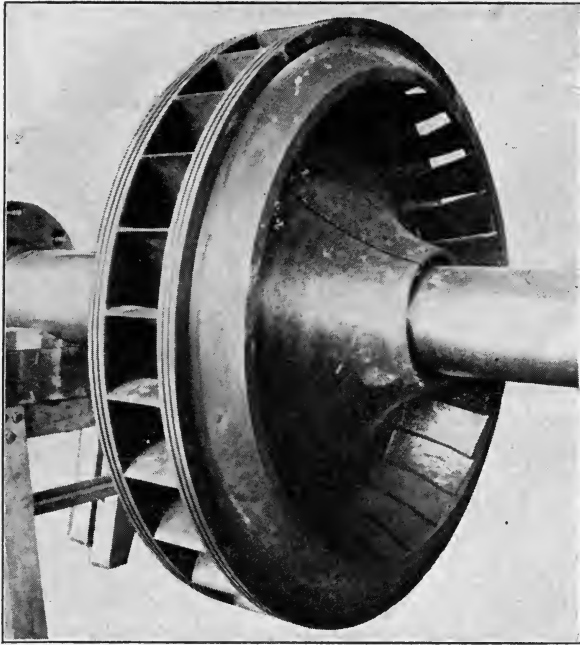

FIG. 153.

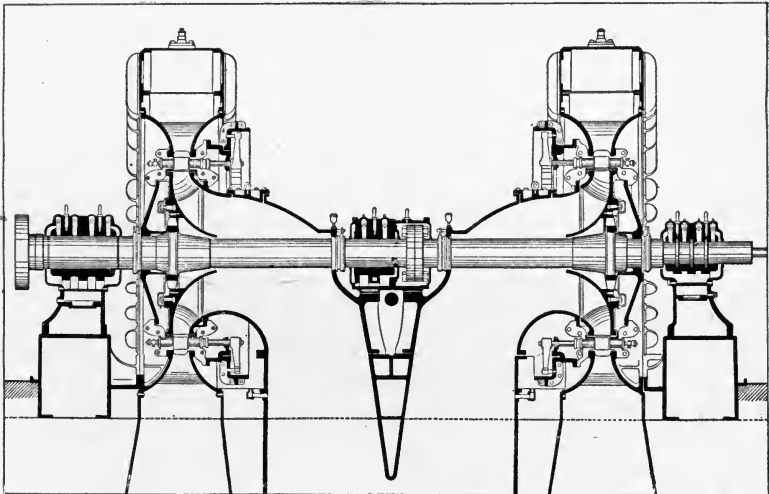

FIG. 154.

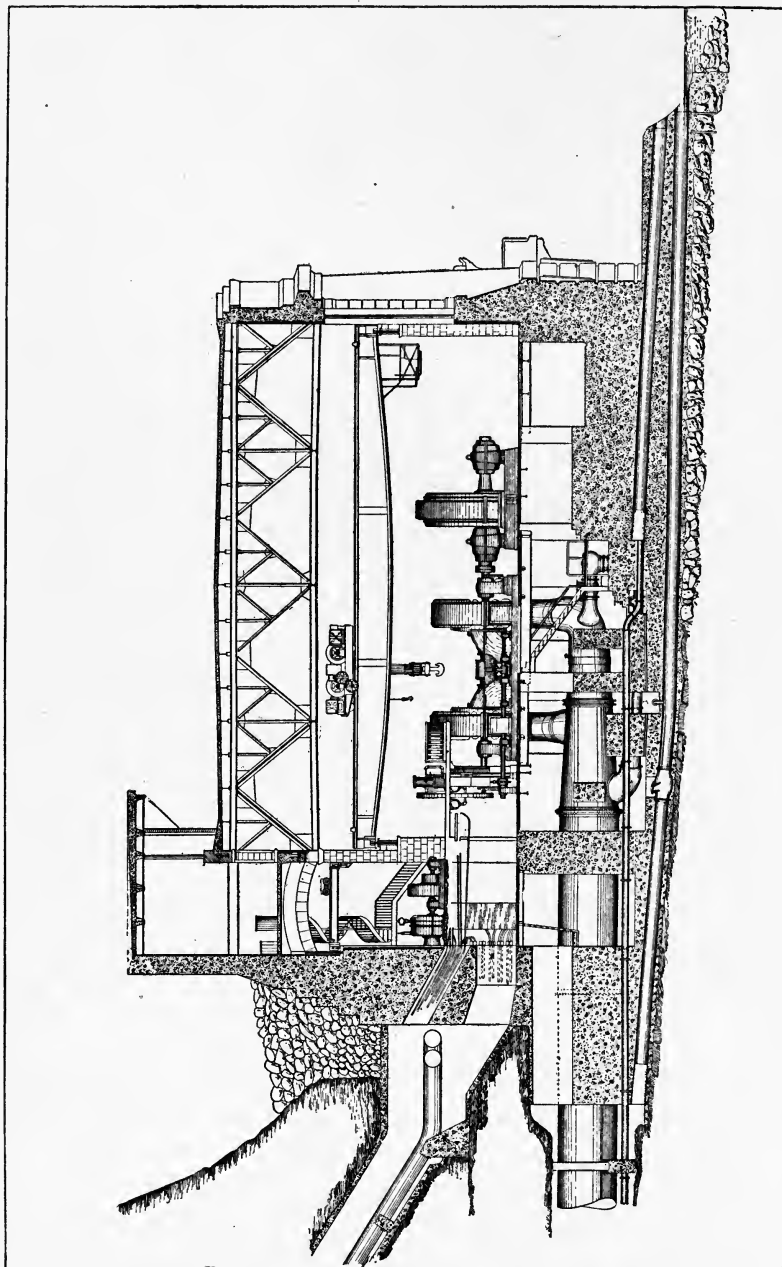

Fig. 155.—Cross section of generating station of the Ontario Power Co., Niagara Falls.

of this type, the water from the conduit or penstock, after passing through the shut-off valves, enters a cast-iron or cast-steel casing of spiral form encircling the runner, by which it is delivered to the whole circumference of the runner at a uniform velocity (Fig. 157). The detail of the gate work for regulating the admission of water to the runner is shown in Fig. 158, and the entire turbine unit is shown in perspective in Fig. 159.

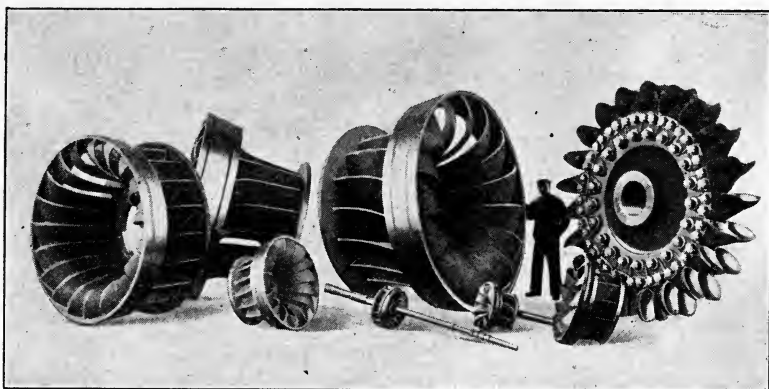

FIG. 156.—American turbine runners built by the Allis Chalmers Manufacturing Co.

**Use of Draft Tube.**—In a reaction, or pressure, turbine the passages between the vanes are completely filled with water, and since this is the case, it will run submerged. By the use of a draft tube or suction tube, invented by Jonval in 1843, it is possible, however, to set the turbine above the level of the tail water without losing head (Fig. 160). This is due to the fact that the pressure at the upper end of the draft tube is enough less than atmospheric to compensate for the loss of hydrostatic pressure at the point of entrance to the wheel. In fact, by the use of a flaring draft tube the efficiency may be slightly increased. The chief advantage of a draft tube, however, is that its use permits of setting the turbine in a more accessible position without any sacrifice of head.

The effect of using a draft tube may be explained mathematically as follows:—In Figure 161 let *B* refer to the point at which water enters the turbine, and *C* to its point of exit into

the draft tube. Then writing out Bernoulli's theorem between the points *A* and *B*, we obtain the relation

$$\frac{v_A^2}{2g} + \frac{p_A}{\gamma} + h = \frac{v_B^2}{2g} + \frac{p_B}{\gamma} + h_2.$$

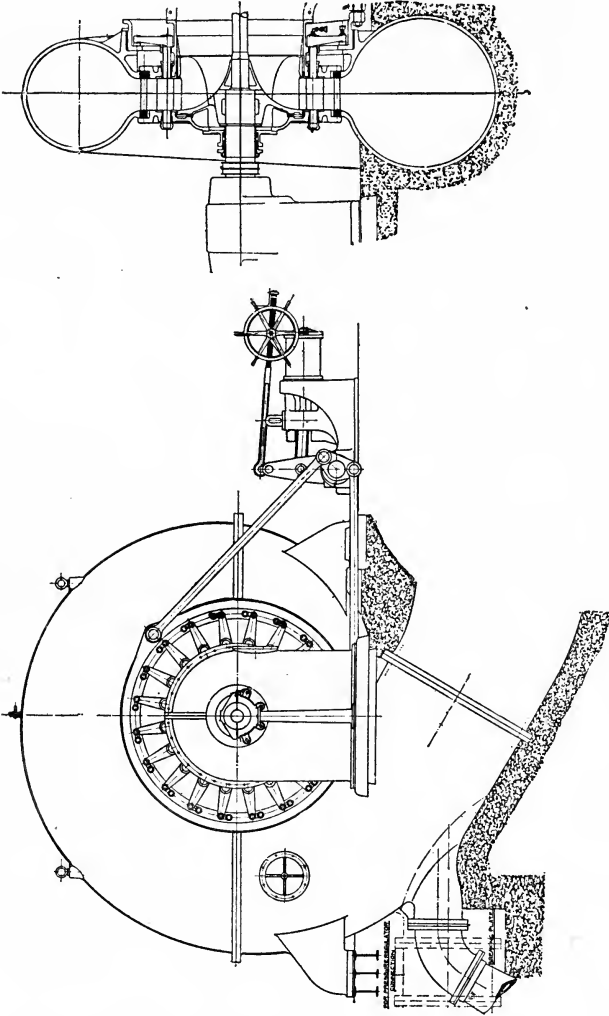

FIG. 157.

Since the intake tube is assumed to be of uniform cross section, we have

$$v_A = v_B,$$

and consequently the above equation reduces to

$$\frac{p_B}{\gamma} = \frac{p_A}{\gamma} + (h - h_2) = \frac{p_A}{\gamma} + h_1.$$

The pressure head at entrance,  $B$ , is therefore simply that due to the static head  $h_1$  plus that due to the atmospheric pressure  $p_A$ .

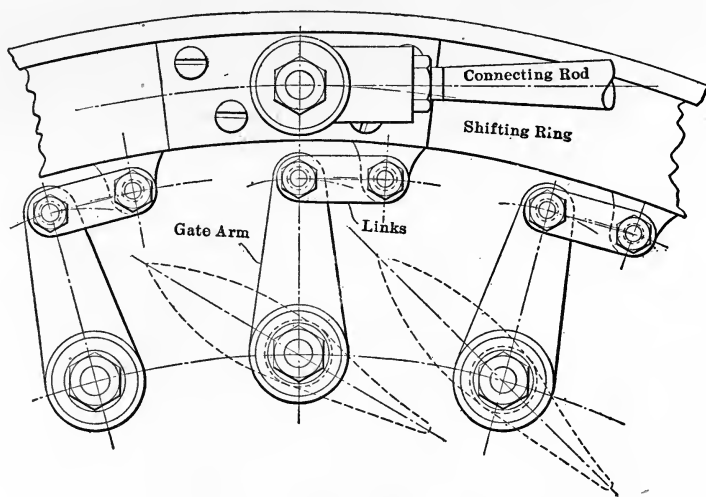

FIG. 158

Similarly, writing Bernoulli's equation between the points  $C$  and  $D$ , we have

$$\frac{v_C^2}{2g} + \frac{p_C}{\gamma} + h_2 = \frac{v_D^2}{2g} + \frac{p_D}{\gamma} + 0,$$

whence

$$\frac{p_C}{\gamma} = \frac{p_D}{\gamma} - h_2 - \frac{(v_C^2 - v_D^2)}{2g}.$$

The effective pressure head on the runner, however, is the difference in pressure between the entrance  $B$  and the exit  $C$ ; that is

$$\text{Effective head} = \frac{p_B}{\gamma} - \frac{p_C}{\gamma}.$$

Substituting the values just obtained for  $p_B$  and  $p_C$ , we have, therefore,

$$\text{Effective head} = \left( \frac{p_A}{\gamma} - \frac{p_D}{\gamma} \right) + h_1 + h_2 + \frac{v_C^2 - v_D^2}{2g}.$$

But since the pressures at  $A$  and  $D$  are atmospheric, we have  $p_A = p_D$ . Also  $h_1 + h_2 = h$ . Consequently this relation becomes

$$\text{Effective head} = h + \frac{(vc^2 - v_D^2)}{2g}$$

This, however, neglects all frictional losses in the intake and

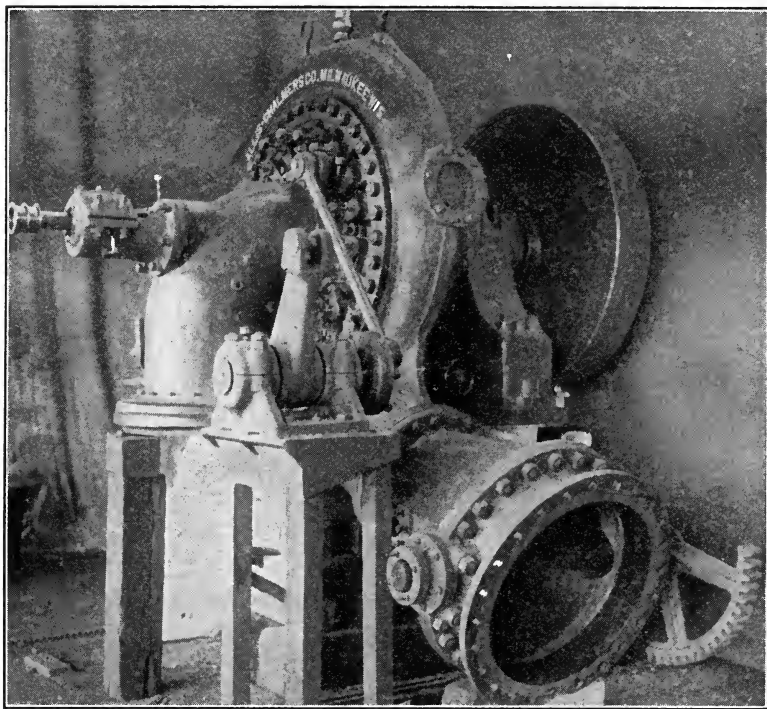

FIG. 159.—Single horizontal spiral cased turbine, 4000 H. P., 720 r. p. m., 550 ft. head. Built for the Cleveland Cliffs Iron Co., Marquette, Mich., by the Allis Chalmers Manufacturing Co.

draft tubes. Including such losses, the actual expression for the effective head becomes

$$\text{Effective head} = h + \frac{(vc^2 - v_D^2)}{2g} - \text{friction head.}$$

Provided the head,  $h_2$ , in the draft tube, does not exceed the ordinary suction head, say about 25 feet, the use of a draft tube therefore produces no loss in the static head,  $h$ . Furthermore, by the use of a flaring draft tube the velocity of flow at

the outlet of the draft tube may be made considerably less than that at the inlet; that is, for a flaring tube,  $v_D < v_C$ . In this case the term  $\frac{v_C^2 - v_D^2}{2g}$  is positive; consequently the effective head

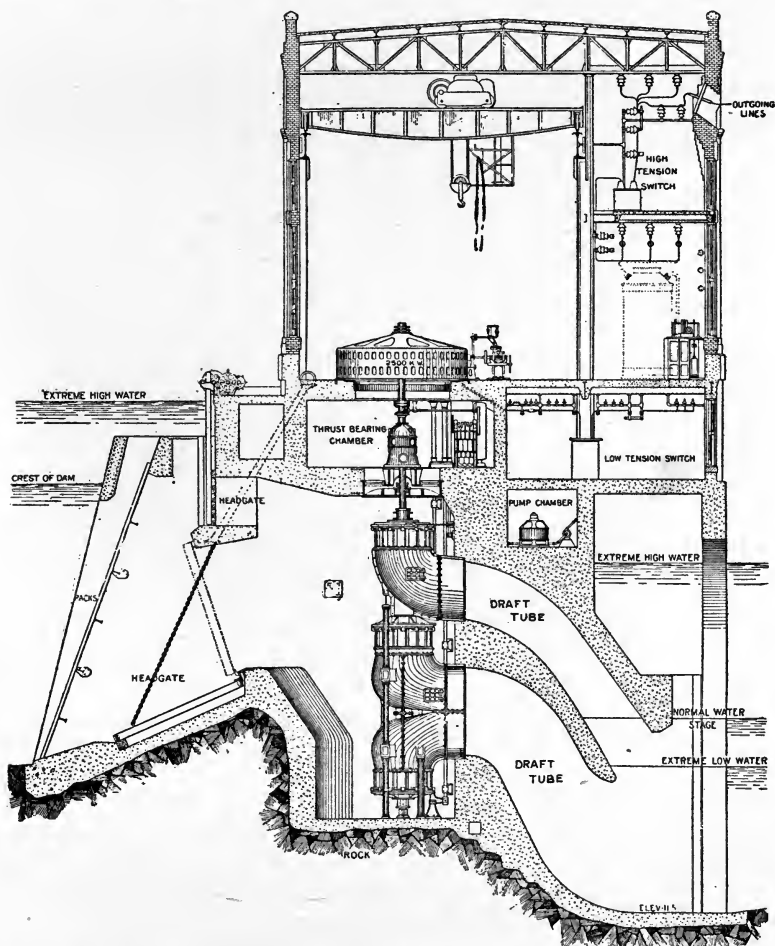

FIG. 160.—Vertical shaft, multi-runner type turbine, showing use of draft tubes. S. Morgan Smith Co.

is increased by this amount, and is therefore greater than if no draft tube was used.

**Recent Practice in Turbine Setting.**—A typical illustration of recent development in the design and installation of

reaction turbines in the United States is furnished by the plant of the Mississippi River Power Co. at Keokuk, Iowa (see frontispiece). These turbines are of the Francis type, with runners 16 ft. 2 in. in nominal diameter and develop 10,000 H.P. per unit at a speed of 57.7 r.p.m. under a head of 32 ft., with an overload capacity of 13,000 H.P. The rated efficiency of the turbines is 88 per cent.

The special feature which makes this installation typical of recent turbine development is the fact that each of the 30 units

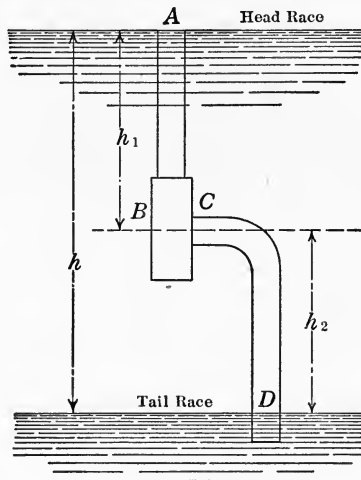

FIG. 161.

is of the single runner vertical shaft type as shown in Fig. 162. The trend of present development of the reaction turbine seems to indicate a still wider application of this type to all conditions of head and speed, and that the single runner vertical shaft turbine will eventually supersede the multi-runner horizontal shaft type (Fig. 154) and the multi-runner vertical shaft type (Fig. 160).

In the Keokuk plant the intakes and draft tubes are of concrete moulded in the substructure of the power house. The water from the forebay reaches each turbine through four intake openings, the outer dimensions of which are 22 ft. by 7-1/2 ft., leading into a scroll chamber 39 ft. in diameter (Fig. 163). The draft tube is circular and 18 ft. in diameter immediately below the runner, but at once enlarges and changes in direction from vertical





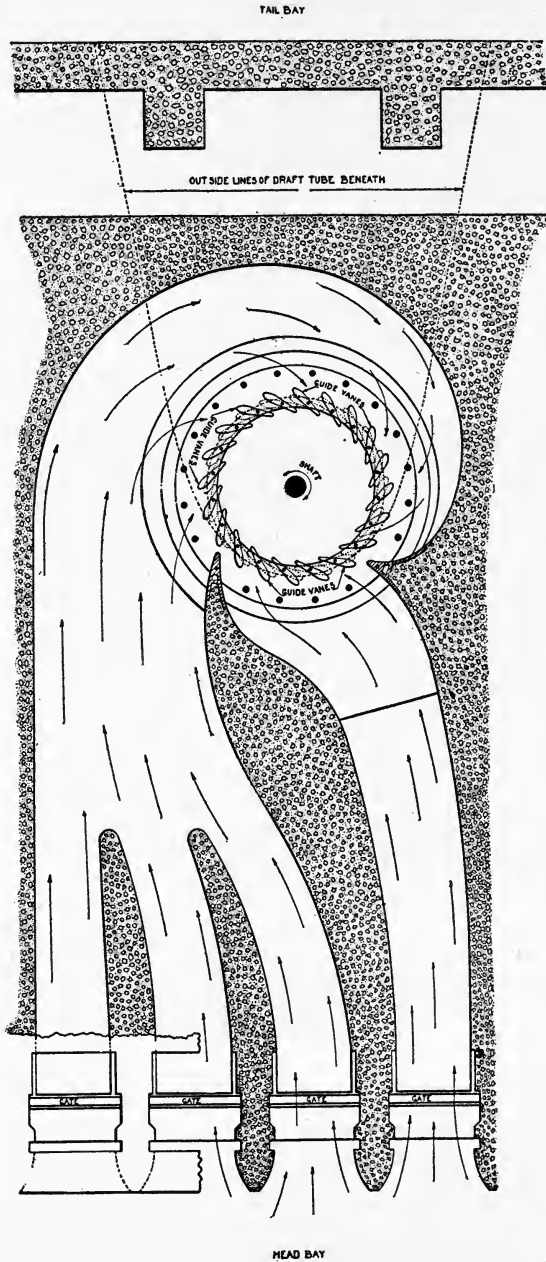

Fig. 163.—Intake, Mississippi River Power Co.

to horizontal, and also changes in cross section from circular to rectangular. The velocity of flow is thereby diminished from 14 ft. per second at the top of the draft tube to 4 ft. per second at the outlet, the effect being to increase the efficiency about 7 per cent. This type of construction is also representative of recent practice, which seems to favor the moulding of the volute casing directly in the substructure of the power house for all low head work. For heads exceeding 100 ft., the amount of reinforcement in the concrete becomes so great as to warrant the use of cast-iron casings, and for heads exceeding 250 ft. the use of cast steel for turbine casings is standard practice.

In the vertical shaft turbine the weight is carried on a thrust bearing, the design of which has been one of the most important considerations affecting the adoption of this type. In the Keokuk plant the turbine runner is coupled to the generator above by a shaft 25 in. in diameter the total weight of the revolving parts, amounting to 550,000 lb., being carried on a single thrust bearing 6 ft. in diameter. This bearing is of the oil pressure type, a thin film of oil being maintained at a pressure of 250 lb. per square inch between the faces of the bearings. As a momentary failure of the oil supply would result in the immediate destruction of the bearing, provision is made for such an emergency by introducing an auxiliary roller bearing which is normally unloaded. A slight decrease in the oil supply, however, allows the weight to settle on this roller bearing, which although not intended for permanent use is sufficiently large to carry the weight temporarily until the turbine can be shut down.

The oil pressure bearing when taken in connection with the necessary pumps and auxiliary apparatus is expensive to install and maintain, and requires constant inspection. For this reason the roller bearing and the Kingsbury bearing are now being applied to large hydro-electric units. One of the first installations in which the roller bearing was applied to large hydraulic units was at the McCall Ferry Plant of the Pennsylvania Water and Power Co., where both the roller and the Kingsbury type of bearing are now in satisfactory use.

### 36. CHARACTERISTICS OF IMPULSE WHEELS AND REACTION TURBINES

**Selection of Type.**—The design of hydraulic turbines is a highly specialized branch of engineering, employing a relatively

small number of men, and is therefore outside the domain of this book. On account of the rapid increase in hydraulic development, however, every engineer should have a general knowledge of turbine construction and type characteristics so as to be able to make an intelligent selection of type and size of turbine to fit any given set of conditions. For this reason the following explanation is given of the use and significance of commercial turbine constants, such, for instance, as those given in the runner table on page 193.

**Action and Reaction Wheels.**—The two systems of hydraulic power development now in use in this country are the impulse wheel and the radial inward flow pressure turbine. When an impulse wheel is used, the total effective head on the runner is converted into speed at entrance and this type is therefore sometimes called an action wheel. In the case of a pressure turbine, however, the effective head on the runner is not all converted into speed at entrance, the entrance speed being smaller than the spouting velocity, so that the water flows through the runner under pressure, the effect of which is to accelerate the stream as it passes over the runner. A pressure turbine is therefore called a reaction wheel.

Reaction turbines are generally used for heads between 5 and 500 ft., and impulse wheels for heads between about 300 and 3000 ft.<sup>1</sup> While there is no doubt as to the system proper for very low or very high heads, there is a certain intermediate range, say from 300 to 500 ft., for which it is not directly apparent which system is most suitable. To determine the proper system within this range, the criterion called the *characteristic speed* has been introduced, as explained in what follows.

**Speed Criterion.**—In determining the various criteria for speed, capacity, etc., the following notation will be used.

- Let  $h$  = net head in feet at turbine casing,  
       = gross head minus all losses in head race, conduit and tail race;  
 $d$  = mean entrance diameter of runner in feet;  
 $b$  = height of guide casing in feet;

<sup>1</sup> At the hydro-electric plant of the Georgia Railway and Power Co. at Tallulah Falls, Georgia, the hydraulic head is 600 ft., which is probably the highest head that has been developed east of the Rocky Mountains, and the highest in this country for which the reaction type of turbine has been employed. (General Electric Review, June 1914, pp. 608-621.)

- $n$  = runner speed in r.p.m.;  
 $v$  = spouting velocity in feet per second;  
 $u_1$  = peripheral velocity of runner in feet per second;  
 $U_1 = \frac{u_1}{v}$  = ratio of peripheral speed of runner to spouting velocity of jet.

From Eq. (23), Art. 8, the spouting velocity in terms of the head is given by the relation

$$v = C \sqrt{2gh}$$

where the constant  $C = 0.96$  to  $0.97$ .

For maximum efficiency the peripheral velocity of the runner is some definite fraction of the ideal velocity of the jet  $\sqrt{2gh}$ , that is,

$$u_1 = \varphi \sqrt{2gh} \quad (100)$$

where  $\varphi$  denotes a proper fraction. For tangential or impulse wheels the average value of  $\varphi$  is from 0.45 to 0.51, whereas for reaction turbines its value ranges from 0.49 to 0.96, with an average range from about 0.57 to 0.87.<sup>1</sup>

The ratio  $U_1$  of peripheral speed of runner to spouting velocity is therefore given by the expression

$$U_1 = \frac{u_1}{v} = \frac{\varphi}{C}$$

and consequently  $U_1$  is about 3 per cent. more than  $\varphi$ .

Since in Eq. (100) the factor  $\varphi\sqrt{2g}$  is a constant, this equation may be written in the form

$$u_1 = k_v \sqrt{h},$$

where the coefficient  $k_v$  may be called the *speed constant*. For a given runner for which  $d$ ,  $h$  and  $n$  are known, this speed constant may be calculated from the relation

$$k_v = \frac{u_1}{\sqrt{h}} = \frac{\pi dn}{60\sqrt{h}} \quad (101)$$

<sup>1</sup> For the numerical values of these and other constants given in this article see the periodical literature cited in succeeding footnotes. Also Gelpke and Van Cleve, *Hydraulic Turbines*, pp. 131-167; Thurso, *Modern Turbine Practice*, pp. 37-56; Mead, *Water Power Engineering*, pp. 326-351; Daugherty, *Hydraulic Turbines*, pp. 101-105.

By the use of the speed constant  $k_v$ , different types of runners may be compared as regards speed. In the case of reaction turbines if the speed constant is much in excess of 7, either the speed is too high for maximum efficiency or the nominal diameter of the runner is larger than its mean diameter.

**Capacity Criterion.**—The entrance area  $A$  of the runner is given by the relation

$$A = c_1\pi db$$

where  $c_1$  denotes a proper fraction, since the open circumference is somewhat less than the total circumference by reason of the space occupied by the ends of the vanes or buckets. The velocity of the stream normal to this entrance area is the radial component of the actual velocity at entrance, say  $u_r$ , and like this velocity is a multiple of  $\sqrt{h}$ , say

$$u_r = c_2\sqrt{h}.$$

Since the discharge  $Q$  is the passage area multiplied by the speed component normal to this area, we have

$$Q = Au_r = (c_1\pi db)c_2\sqrt{h}.$$

It is customary, however, to express the height of a runner in terms of its diameter as

$$b = c_3d,$$

where the coefficient  $c_3$  is a constant for homologous runners of a given type. For American reaction turbines  $c_3$  varies from about 0.10 to 0.30. Substituting this value for  $b$  in the expression for the discharge, it becomes

$$Q = (\pi c_1 c_2 c_3) d^2 \sqrt{h}.$$

Therefore if the constant part of this expression is denoted by  $k_q$ , it may be written

$$Q = k_q d^2 \sqrt{h}. \quad (102)$$

The coefficient  $k_q$  may be called the *capacity constant* of the runner, and for any given runner may be computed from the relation

$$k_q = \frac{Q}{d^2 \sqrt{h}}. \quad (103)$$

For American reaction turbines the capacity constant ranges in value from about 2 to 4. Since  $k_q$  has approximately the same

value for all runners of a given type, it serves as a criterion for comparing the capacities of runners of different types.

**Characteristic Speed.**—The speed constant and capacity constant taken separately are not sufficient to fix the requirements of combined speed and capacity. That is to say, two runners may have different values of  $k_v$  and  $k_q$  and yet be equivalent in operation. To fix the type, therefore, another criterion must be introduced which shall include both  $k_v$  and  $k_q$ . The most convenient combination of these constants is that introduced by Professor Camerer of Munich and the well-known turbine designer, Mr. N. Baashuus of Toronto, Ontario. This criterion may be obtained as follows.<sup>1</sup>

The horse power of a turbine is given by the expression

$$\text{H.P.} = \frac{62.37Qhe}{550}$$

where  $e$  denotes the hydraulic efficiency of the turbine. If the horse power, discharge  $Q$  and head  $h$  are given, the efficiency may be calculated from this relation by writing it in the form

$$e = \frac{550\text{H.P.}}{62.37Qh}$$

If the efficiency is known, the constants in the above expression for the horse power may be combined into a single constant  $k$ , and the equation written in the form

$$\text{H.P.} = kQh. \quad (104)$$

When the efficiency is not known it is usually assumed as 80 per cent., in which case  $k = \frac{1}{11}$ .

From Eq. (101) the speed in r.p.m. is given by the relation

$$n = \frac{60k_v \sqrt{h}}{\pi d} \quad (105)$$

and from Eq. (103) the nominal diameter of the runner is given as

$$d = \sqrt{\frac{Q}{k_q \sqrt{h}}}$$

Eliminating  $d$  between these two relations, we have therefore

$$n = \frac{60 k_v \sqrt{k_q} \sqrt{h} \sqrt[4]{h}}{\pi \sqrt{Q}}$$

<sup>1</sup> S. G. Zowski: A Comparison of American Highspeed Runners for Water Turbines. Engineering News, Jan. 28, 1909, pp. 99-102.

Moreover, from Eq. (104) we have

$$Q = \frac{H.P.}{kh},$$

and substituting this value of  $Q$  in the preceding expression for  $n$ , we have finally

$$n = \left( \frac{60k_r \sqrt{k_g} \sqrt{k}}{\pi} \right) \frac{h\sqrt[4]{h}}{\sqrt{H.P.}}. \quad (106)$$

The expression in parenthesis is a constant for any given type and may be denoted by  $N_s$ , in which case we have

$$n = N_s \frac{h\sqrt[4]{h}}{\sqrt{H.P.}}$$

For any given type of turbine this constant  $N_s$  may be calculated from the relation

$$N_s = \frac{n \sqrt{H.P.}}{h\sqrt[4]{h}}. \quad (107)$$

Various names have been proposed for this constant  $N_s$  such as "type constant" and "type characteristic." In Germany, where its importance as determining the type and performance of a turbine seems to have first been recognized, it is called the *specific speed* (spezifische Geschwindigkeit, or spezifische Umlaufzahl). This term, however, is not entirely satisfactory to American practice, as it seems desirable to use the term specific speed in another connection, as explained in what follows. The term for the constant  $N_s$  favored by the best authorities as more fully describing its meaning is *characteristic speed*, which is therefore the name adopted in this book.<sup>1</sup>

For impulse wheels the characteristic speed ranges in value from about 1 to 5, while for radial, inward flow turbines its value lies between 10 and 100.

**Specific Discharge.**—It is convenient to express the discharge, power, speed, etc., in terms of their values under a 1 ft. head.

The discharge under a 1 ft. head is called the *specific discharge*, and its value is found by substituting  $h = 1$  in Eq. (102).

<sup>1</sup>The use of the term *characteristic speed* has been recommended to the author by the well known hydraulic engineer Mr. W. M. White, who is using this term in preparing the American edition of the German handbook "de Hütte," and strongly advocates its general adoption in American practice.



Consequently if the specific discharge is denoted by  $Q_1$ , its value is

$$Q_1 = k_q d^2,$$

and therefore

$$Q = Q_1 \sqrt{h}. \quad (108)$$

For reaction turbines the specific discharge ranges in value from  $0.302d^2$  for the slowest speeds to  $2.866d^2$  for the highest speeds, the diameter  $d$  being expressed in feet.

**Specific Power.**—Similarly, the power developed under 1 ft. head is called the *specific power* and will be denoted in what follows by H.P.<sub>1</sub>. From Eq. (104) we have

$$\text{H.P.} = kQh$$

and since from Eq. (102)

$$Q = k_q d^2 \sqrt{h},$$

by eliminating  $Q$  between these two relations we have

$$\text{H.P.} = k k_q d^2 h \sqrt{h}.$$

Substituting  $h = 1$  in this equation, the specific power is therefore given as

$$\text{H.P.}_1 = k k_q d^2,$$

and consequently

$$\text{H.P.} = \text{H.P.}_1 h \sqrt{h}. \quad (109)$$

**Specific Speed.**—By analogy with what precedes, the speed under 1 ft. head will be called the *specific speed* and denoted by  $n_1$ . Substituting  $h = 1$  in Eq. (105), we have therefore

$$n_1 = \frac{60k_v}{\pi d},$$

and consequently

$$n = n_1 \sqrt{h}. \quad (110)$$

For reaction turbines the specific speed ranges in value from  $\frac{78}{d}$  for the lowest speeds, to  $\frac{147}{d}$  for the highest speeds, the diameter  $d$  being expressed in feet.

**Relation between Characteristic Speed and Specific Speed.**—From the relation

$$N_s = \frac{n \sqrt{\text{H.P.}}}{h^4 \sqrt{h}},$$

the *characteristic speed*  $N_s$  may be defined in terms of the quantities defined above as *specific*. Thus, assuming  $h = 1$  and  $H.P. = 1$ , we have  $N_s = n$ , expressed in r.p.m. Therefore, *the characteristic speed is the speed in r.p.m. of a turbine diminished in all its dimensions to such an extent as to develop 1 H.P. when working under a head of 1 ft.*

Since it is apparent from Eq. (106) that  $N_s$  stands for the combination

$$N_s = \frac{60k_v \sqrt{k_q} \sqrt{k}}{\pi}$$

where  $k$  is a function of the efficiency  $e$ , the characteristic speed  $N_s$  is an absolute criterion of turbine performance as regards speed, capacity and efficiency. From Eq. (107), however, it is evident that  $N_s$  may be calculated directly from the speed, power and head without knowing the actual dimensions of the runner, its discharge, or its efficiency.

**Classification of Reaction Turbines.**—The characteristic speed  $N_s$  may be used as a means of classifying both the various types of impulse wheels and of reaction, or pressure, turbines.

In the following table practically all the different kinds of pressure turbines of the radial inward flow type are classified by their characteristic speeds, the corresponding efficiencies being also given in each case.<sup>1</sup>

Type of pressure turbine	Characteristic speed, $N_s$	Efficiency	
		Maximum	At half power
Low speed.....	10 - 20	82 per cent. at 3/4 power	76 per cent.
Medium speed...	30 - 50	82 per cent. at 3/4 power	75 per cent.
High speed.....	60 - 80	80 per cent. at 0.8 power	70 per cent.
Very high speed.	90 -100	73 per cent. at 0.9 power	53 per cent.

The values of the constant  $N_s$  in this table refer to the maximum power of one runner only. In case the characteristic speed is higher than 100, it is necessary to use a multiple unit. At maximum power, the efficiencies are slightly lower than the maximum efficiencies given above.

From this table it is apparent that low speed turbines show a favorable efficiency over a wide range of loads but are practically limited to high heads, whereas high speed turbines are efficient at about 0.8 load but show a notable decrease in effi-

<sup>1</sup> Water Power Plants and the Type Characteristics of Turbines. N. Baashuus, Engineering News, Mar. 2, 1911, pp. 248-250.

ciency at half load. The use of the latter is therefore indicated for low heads where the water supply is ample at all seasons.

**Classification of Impulse Wheels.**—In a way similar to the preceding, the characteristic speed may be used to classify the various types of impulse wheels, as indicated in the following table.<sup>1</sup>

Impulse wheels					
$N_s$	1	2	3	4	5
Efficiency at 3/4 load.	80 per cent.	79 per cent.	78 per cent.	77 per cent.	76 per cent.

The numerical values of  $N_s$  in this table refer to the maximum power of one nozzle only. In case the characteristic speed lies between 5 and 10 it is therefore necessary to use more than one nozzle.

**Numerical Applications.**—To illustrate the use of the preceding numerical data, suppose that it is required to determine the proper system of hydraulic development for a power site with an available flow of 310 cu. ft. per second under an effective head of 324 ft.

The power capacity in this case is

$$\text{H.P.} = \frac{324 \times 310}{11} = 9100.$$

Of this amount about 100 H.P. will be required for exciter and lighting purposes. There would therefore be installed two exciter units running at 550 r.p.m., one of which would be a reserve unit. The characteristic speed for these units would then be

$$N_s = \frac{550}{310} \sqrt{\frac{100}{17.6}} = 4.25.$$

Since this lies between 1 and 5, an impulse wheel would be used for driving the exciter generators.

The main development of 9000 H.P. would be divided into three units of 3000 H.P. each, running at 500 r.p.m., with a fourth unit as a reserve. The characteristic speed for these main units would then be

$$N_s = \frac{500}{310} \sqrt{\frac{3000}{17.6}} = 21.$$

As  $N_s$  lies between 10 and 100, a pressure turbine would be used for driving the main generators.

<sup>1</sup> Water Power Plants and the Type Characteristics of Turbines. N. Baashuus, Engineering News, Mar. 2, 1911, pp. 248-250.

As a second illustration, suppose that an impulse wheel is required to develop 1300 H.P. under a 400 ft. head at an efficiency of not less than 78 per cent. From the preceding table for impulse wheels it is apparent that it is necessary to use a wheel having a characteristic speed of about 3. If a single wheel and nozzle is used, the speed in r.p.m. at which it must run is found from Eq. (107) to be

$$n = N_s h \sqrt{\frac{\sqrt{h}}{H.P.}} = 3 \times 400 \sqrt{\frac{20}{1300}} = 150 \text{ r.p.m.}$$

If two nozzles are used, each furnishes half of the power and the corresponding speed is  $150\sqrt{2} = 212$  r.p.m.

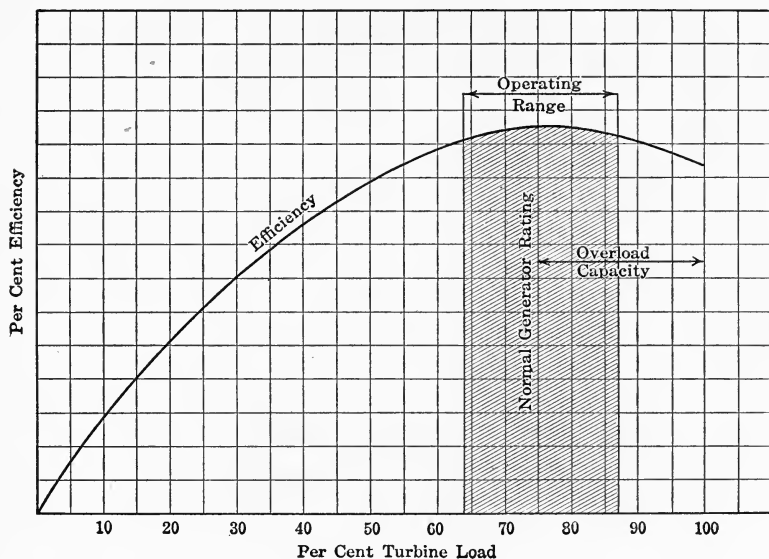

FIG. 164.

With four nozzles acting on two runners the required speed would be  $150\sqrt{4} = 300$  r.p.m., and for 6 nozzles acting on 3 runners,  $n = 150\sqrt{6} = 367$  r.p.m. Since the value of  $N_s$  is the same in each case, the efficiency is practically 78 per cent. in each case although there is a wide difference in the speed and setting.

**Normal Operating Range.**—Having determined the proper type of development, it is necessary, in case a reaction turbine is used, to determine the required size and type of runner to

develop maximum efficiency under the given conditions of operation.

For a turbine direct connected to a generator, the capacity of the turbine, in general, should be such as to permit the full overload capacity of the generator to be developed and at the same time place the normal operating range of the unit at the point of maximum efficiency of the turbine, as indicated in Fig. 164. The normal horse power, or full-load, here means the power at which the maximum efficiency is attained, any excess power being regarded as an overload.

When the supply of water is ample but the head is low, efficiency may to a certain extent be sacrificed to speed and capacity in order that the greatest power may be developed from each runner, thereby reducing the investment per horse power of the installation. On the other hand, when the flow of water is insufficient to meet all power requirements, an increase in efficiency shows a direct financial return in the increased output of the plant.

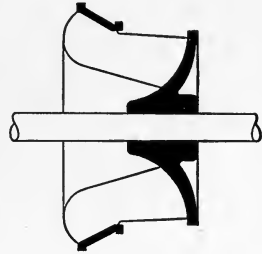

FIG. 165.

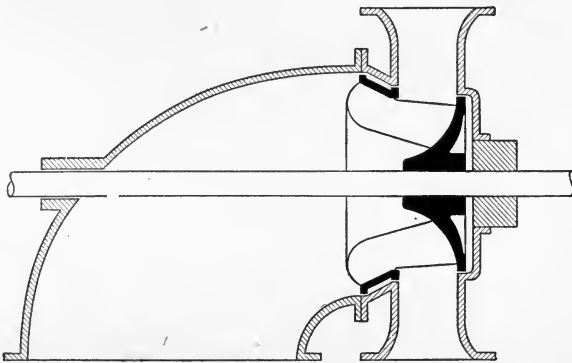

FIG. 166.

**Selection of Stock Runner.**—Ordinarily it is required to select a stock runner which will operate most favorably under the given conditions. To explain how an intelligent selection of size and type of runner may be made from the commercial constants given by manufacturers, the following runner table of a standard make of turbine is introduced.<sup>1</sup> (Page 193.)

<sup>1</sup> The Allis-Chalmers Company, Milwaukee.

The cut accompanying each of the six types given in the table shows the outline of runner vane for this type. To indicate its relation to the runner and to the turbine unit as a whole, Fig.

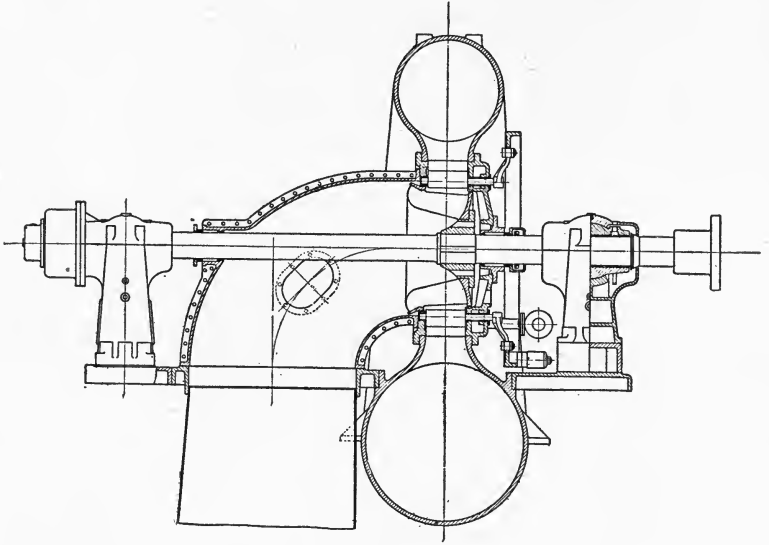

FIG. 167.

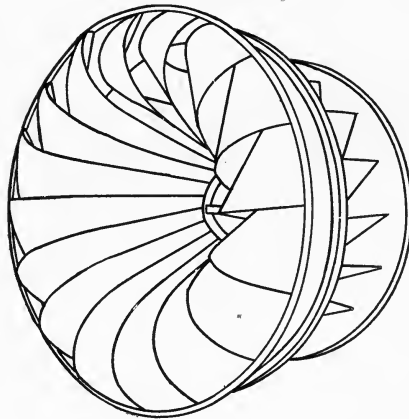
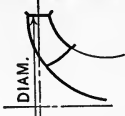
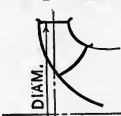
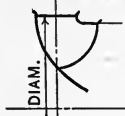
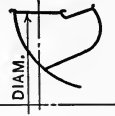



FIG. 168.

165 shows a typical cross section of runner; Fig. 166 shows how this is related to the casing; and Fig. 167 shows a cross section of the entire turbine unit. The runner is also shown in perspective in Fig. 168.

TYPE "A" RUNNER				TYPE "B" RUNNER			TYPE "C" RUNNER		
									
$N_s = 13.55$ $U_1 = 0.585$				$N_s = 20.3$ $U_1 = 0.625$			$N_s = 29.4$ $U_1 = 0.665$		
Diam.	R.P.M. <sub>1</sub>	H.P. <sub>1</sub>	Q <sub>1</sub>	R.P.M. <sub>1</sub>	H.P. <sub>1</sub>	Q <sub>1</sub>	R.P.M. <sub>1</sub>	H.P. <sub>1</sub>	Q <sub>1</sub>
15	71.7	0.0358	0.394	76.6	0.0705	0.776	81.4	0.130	1.43
18	59.8	0.0514	0.565	63.8	0.105	1.155	67.8	0.187	2.06
21	51.2	0.0705	0.776	54.7	0.138	1.523	58.2	0.225	2.48
24	44.8	0.0915	1.007	47.8	0.182	2.00	51.0	0.333	3.66
27	39.8	0.116	1.276	42.5	0.229	2.52	45.2	0.423	4.65
30	35.8	0.142	1.562	38.3	0.284	3.12	40.7	0.520	5.72
34	31.6	0.184	2.024	33.8	0.363	3.99	35.9	0.668	7.35
38	28.3	0.230	2.53	30.2	0.453	4.98	32.2	0.835	9.19
42	25.6	0.280	3.08	27.4	0.551	6.06	29.1	1.016	11.18
46	23.4	0.336	3.69	25.0	0.665	7.32	26.6	1.225	13.48
50	21.5	0.398	4.38	23.0	0.79	8.69	24.4	1.450	15.95
55	19.5	0.480	5.28	20.9	0.95	10.45	22.2	1.745	19.20
60	17.9	0.573	6.30	19.1	1.13	12.43	20.4	2.08	22.88
65	16.5	0.672	7.39	17.7	1.33	14.63	18.8	2.44	26.84
70	15.4	0.785	8.64	16.4	1.53	16.83	17.5	2.82	31.00

TYPE "D" RUNNER				TYPE "E" RUNNER				TYPE "F" RUNNER			
											
$N_s = 40.7$ $U_1 = 0.70$				$N_s = 51.7-60.5$ $U_1 = 0.75$				$N_s = 71.4-79$ $U_1 = 0.85$			
Diam.	R.P.M. <sub>1</sub>	H.P. <sub>1</sub>	Q <sub>1</sub>	Diam.	R.P.M. <sub>1</sub>	H.P. <sub>1</sub>	Q <sub>1</sub>	R.P.M. <sub>1</sub>	H.P. <sub>1</sub>	Q <sub>1</sub>	
				14	98.4	0.277	3.05	111.5	0.410	4.51	
				16	86.1	0.367	4.04	97.7	0.541	5.95	
				18	76.5	0.471	5.18	86.8	0.704	7.74	
15	85.7	0.226	2.49	20	69.0	0.597	6.57	78.1	0.912	10.03	
18	71.4	0.324	3.56	22	62.6	0.731	8.04	71.0	1.133	12.46	
21	61.3	0.442	4.86	24	57.4	0.883	9.70	65.1	1.375	15.13	
24	53.6	0.577	6.35	26	53.0	1.055	11.60	60.1	1.62	17.85	
27	47.6	0.731	8.04	28	49.2	1.243	13.67	55.8	1.93	21.25	
30	42.8	0.902	9.92	30	46.0	1.436	15.80	52.1	2.20	24.20	
34	37.8	1.158	12.74	32	43.0	1.65	18.15	48.8	2.55	28.10	
38	33.9	1.444	15.88	34	40.5	1.89	20.80	46.0	2.82	31.10	
42	30.6	1.765	19.4	36	38.3	2.15	23.65	43.5	3.14	34.55	
46	28.0	2.12	23.3	38	36.3	2.42	26.60	41.1	3.52	38.70	
50	25.7	2.50	27.5	40	34.4	2.75	30.25	39.1	3.93	43.20	
55	23.4	3.04	33.4	42 1/2	32.4	3.09	34.0	36.8	4.33	47.60	
60	21.4	3.61	39.7	45	30.6	3.53	38.8	34.7	4.92	54.10	
65	19.8	4.22	46.4	47 1/2	29.0	4.01	44.1	32.9	5.66	62.25	
70	18.4	4.90	53.9	50	27.6	4.45	49.0	31.2	6.13	67.40	
				52 1/2	26.3	4.95	54.5	29.8	6.75	74.25	
				55	25.1	5.52	60.7	28.4	7.50	82.50	
				57 1/2	24.0	6.10	67.1	27.2	8.16	89.75	
				60	23.0	6.80	74.8	26.0	8.94	98.30	

From Eq. (107) it is evident that, other things being equal, the characteristic speed for high heads will be relatively small whereas for low heads it will be large. Thus in the runner table above, type "A," with a characteristic speed of 13.55 is adapted to high heads, running up to 600 ft., while at the other end of the series, type "F," with a characteristic speed of about 75, is adapted to effective heads as low as 10 ft.

To give a numerical illustration of the use of the runner table, suppose it is required to determine the type of runner and the speed in r.p.m. to develop 750 H.P. under a head of 49 ft.

In this case  $h\sqrt{h} = 49\sqrt{49} = 343$ , and consequently

$$\text{H.P.}_1 = \frac{H.P.}{h\sqrt{h}} = \frac{750}{343} = 2.2,$$

which corresponds to a 30-in. type "F" runner. Referring to the table for this type and size, we have  $n_1 = 52.1$ , from which the required speed is found to be

$$n = 52.1\sqrt{h} = 364.7, \text{ say } 360 \text{ r.p.m.}$$

If twin turbines were used, we would have

$$\text{H.P.}_1 = \frac{750}{2h\sqrt{h}} = 1.11,$$

which corresponds to a 22-in. type "F" runner, having a speed of

$$n = 71.0\sqrt{h} = 497, \text{ say } 500 \text{ r.p.m.}$$

As a second illustration, let it be required to find from the table the type of runner and speed to develop 4000 H.P. under an effective head of 300 ft.

In this case  $h\sqrt{h} = 300\sqrt{300} = 5190$ , and consequently the specific power is

$$\text{H.P.}_1 = \frac{H.P.}{h\sqrt{h}} = \frac{4000}{5190} = 0.77,$$

which corresponds to a 50-in. type "B" runner. Referring to the table for this type and size we have

$$\text{H.P.}_1 = 0.79, \text{ and } n_1 = 23,$$

and consequently the power and speed for this type and size is

$$\text{H.P.} = 0.79h\sqrt{h} = 4100,$$

and

$$n = 23\sqrt{h} = 395, \text{ say } 400 \text{ r.p.m.}$$



## 37. POWER TRANSMITTED THROUGH PIPE LINE AND NOZZLE

**Effective Head at Nozzle.**—Hydraulic power is frequently delivered through a pipe line and nozzle (as, for instance, when power is developed by an impulse wheel), in which case there is considerable loss due to pipe friction and other causes. To investigate the amount of this loss and the condition for maximum efficiency, let

- $D$  = inside diameter of pipe in feet,  
 $l$  = length of pipe in feet,  
 $h$  = static head at nozzle in feet,  
 $v$  = velocity of flow in feet per second.

To simplify the solution it is customary to neglect the slight loss of head at entrance to the pipe and in the nozzle, as both of these terms are small in comparison with the head lost in pipe friction. From Eq. (48), Art. 17, the head lost in friction in a pipe of length  $l$  is given by the expression

$$\text{Lost friction head} = f \frac{l}{D} \cdot \frac{v^2}{2g}$$

where  $f$  denotes an empirical constant (Eq. (49), Art. 17, and Table 12). Therefore the effective head at the nozzle is

$$\text{Effective head} = h - f \frac{l}{D} \cdot \frac{v^2}{2g}. \quad (111)$$

**Velocity of Flow for Maximum Power.**—Since the discharge  $Q$  is

$$Q = \frac{\pi D^2}{4} v \gamma \text{ lb. per second,}$$

the horse power delivered at the nozzle is

$$\text{H.P. at nozzle} = \frac{\pi D^2 v \gamma}{4 \times 550} \left( h - f \frac{l}{D} \cdot \frac{v^2}{2g} \right).$$

The value of  $v$  for which the horse power is a maximum is found from the calculus condition

$$\frac{d(\text{H.P.})}{dv} = 0,$$

namely,

$$\frac{d(\text{H.P.})}{dv} = \frac{\pi D^2 \gamma}{4 \times 550} \left( h - 3f \frac{l}{D} \cdot \frac{v^2}{2g} \right) = 0,$$

whence

$$v = \sqrt{\frac{2ghD}{3fl}}. \quad (112)$$

**Maximum Efficiency.**—Substituting this value of  $v$  in the expression for the horse power, its maximum value is found to be

$$\text{Max. available H.P.} = \frac{\pi D^2 \gamma h}{6 \times 550} \sqrt{\frac{2ghD}{3fl}}. \quad (113)$$

If there was no friction, the total available horse power would be

$$\text{Total H.P.} = \frac{\pi D^2 v h \gamma}{4 \times 550}.$$

The efficiency  $E$  is therefore

$$E = \frac{\text{actual H.P.}}{\text{total H.P.}} = 1 - f \frac{l}{hD} \frac{v^2}{2g},$$

the maximum value of which, when  $v = \sqrt{\frac{2ghD}{3fl}}$ , is

$$E_{\text{max. power}} = 1 - \frac{1}{3} = \frac{2}{3}. \quad (114)$$

**Diameter of Nozzle for Maximum Output of Power.**—To investigate conditions at the nozzle, let

$p$  = pressure in pounds per square foot before entering the nozzle,

$A$  = area of cross section of pipe,

$a$  = area of cross section of nozzle,

$v$  = velocity of water in pipe,

$V$  = velocity of water through nozzle.

Then since all the water in the pipe discharges through the nozzle, we have  $Av = aV$ , or

$$\frac{A}{a} = \frac{V}{v},$$

and therefore, from Bernoulli's theorem,

$$\frac{p}{\gamma} + \frac{v^2}{2g} = \frac{V^2}{2g} = \left(\frac{A}{a}\right)^2 \frac{v^2}{2g},$$

and also

$$\frac{p}{\gamma} + \frac{v^2}{2g} + f \frac{l}{D} \frac{v^2}{2g} = h.$$

Therefore, by subtraction, we have

$$\left(\frac{A}{a}\right)^2 \frac{v^2}{2g} = h - f \frac{l}{D} \frac{v^2}{2g}$$

whence

$$a = Av \sqrt{\frac{D}{2ghD - flv^2}}.$$

For maximum power the velocity  $v$ , as given by Eq. (112), must be  $v = \sqrt{\frac{2ghD}{3fl}}$ , and inserting this value of  $v$  in the expression just obtained for the nozzle area  $a$ , the condition for maximum output of power is

$$a = A\sqrt{\frac{D}{2fl}} \tag{115}$$

For a circular pipe and nozzle we have

$$a = \frac{\pi d^2}{4} \text{ and } A = \frac{\pi D^2}{4},$$

where  $d$  denotes the nozzle diameter; hence for maximum output we must have

$$d = \sqrt[4]{\frac{D^5}{2fl}} \tag{116}$$

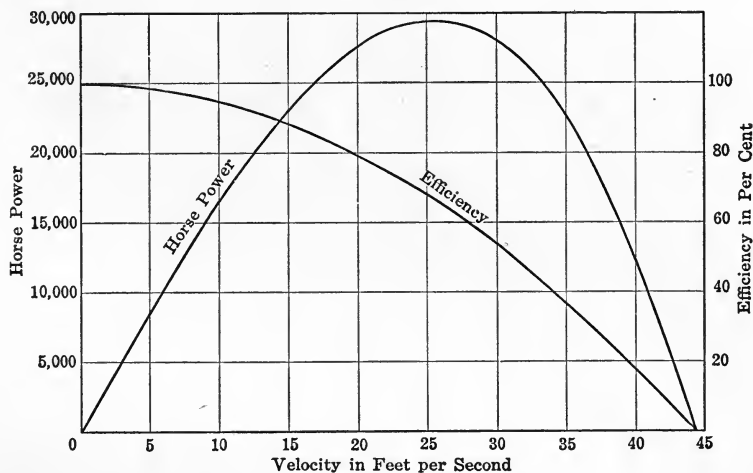

FIG. 169.

**Graphical Relation between Power and Efficiency.**—The relation between horse power and efficiency is shown graphically in Fig. 169 for the installation of the Vancouver Power Co. The length of pipe line in this case was  $l = 6678$  ft., diameter  $D = 4$  ft., and head  $h = 1214$  ft. Assuming  $f = 0.024$ , the horse power at the nozzle is found from the equation

$$\begin{aligned} \text{H.P. at nozzle} &= \frac{\pi D^2 v \gamma}{4 \times 550} \left( h - f \frac{l}{D} \frac{v^2}{2g} \right) \\ &= 1.4257v(1214 - 0.6222v^2). \end{aligned}$$

This is a maximum when

$$v = \sqrt{\frac{2ghD}{3fl}} = 25.5,$$

its value being 29,423 H.P.

The efficiency in per cent. is found from the relation

$$E = \left(1 - f \frac{l}{Dh} \frac{v^2}{2g}\right) 100 = (1 - 0.0005124v^2) 100.$$

The horse power and efficiency, plotted on a velocity base, are shown in Fig. 169.

**Method of Determining Nozzle Diameter.**—In finding the nozzle diameter,  $d$ , a tentative value of  $f$  may be assumed as in the example just cited (see Eq. (48), Art. 17), and the corresponding value of  $v$  found from Eq. (112). The value of  $f$  corresponding to this velocity may then be determined from Table 12, and with this value of  $f$ , the nozzle diameter may be determined from Eq. (116).

Note that the nozzle diameter so determined gives the maximum output of power for the size of pipe specified, but that more power may be developed from the same nozzle by using a larger supply pipe.

### 38. EFFECT OF TRANSLATION AND ROTATION

**Equilibrium under Horizontal Linear Acceleration.**—Consider the equilibrium of a body of water having a motion of translation

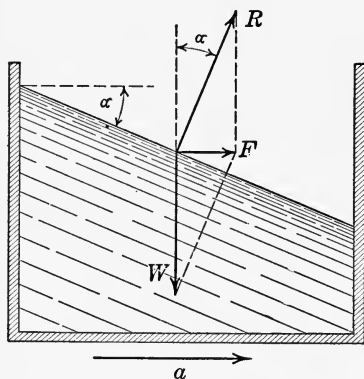

FIG. 170.

as a whole but with its particles at rest relatively to one another, such, for example, as the water in the tank of a locomotive tender when in motion on a straight level track. If the speed is constant, the forces acting on any particle of the liquid are in equilibrium, and conditions are the same as when the tank is at rest. If the motion is accelerated, however, every particle of the liquid must experience an inertia force

proportional to the acceleration. Thus, if the acceleration is denoted by  $a$ , the inertia force  $F$  acting on any particle of mass  $m$ , according to Newton's law of motion, is given by the relation

$$F = ma.$$

For a particle on the free surface of the liquid (Fig. 170), the inertia force  $F$  acting on this particle must combine with its weight  $W$  into a resultant  $R$  having a direction normal to the free surface of the liquid. From the vector triangle shown in the figure we have

$$F = W \tan \alpha,$$

and by Newton's law

$$F = \frac{W}{g} a,$$

whence by division

$$\tan \alpha = \frac{a}{g}. \quad (117)$$

**Equilibrium under Vertical Linear Acceleration.**—If the tank is moving vertically upward or downward, the surface of the liquid will remain horizontal. If the motion is uniform, that is, with constant velocity, the conditions will be the same as though the tank was at rest. If it is moving upward with acceleration  $a$ , the surface will still remain horizontal but the pressure on the bottom of the tank will be increased by the

amount  $ma = \frac{W}{g} a$ , where  $W$  denotes the weight of a column of water of unit cross section and height equal to the depth of water in the tank. Thus if  $p$  denotes the pressure on the bottom of the tank in pounds per square inch, then since  $ma = \frac{W}{g} a = \frac{\gamma h}{g} a$ , we have

$$p = \gamma h + ma = \gamma h \left( \frac{g + a}{g} \right). \quad (118)$$

If the acceleration is vertically downward, the pressure on the bottom of the tank is diminished by the amount  $\gamma h \left( \frac{a}{g} \right)$ , its value being

$$p = \gamma h \left( \frac{g - a}{g} \right). \quad (119)$$

**Free Surface of Liquid in Rotation.**—If the tank is in the form of a circular cylinder of radius  $r$ , and revolves with angular velocity  $\omega$  about its vertical axis  $Y Y$  (Fig. 171), the free surface of the liquid will become curved or dished. To find the form assumed by the surface, let  $P$  denote any particle on the free

surface at a distance  $x$  from the axis of rotation. Then if  $m$  denotes the mass of this particle, the centrifugal force  $C$  acting on it is

$$C = mx \omega^2 = \frac{W}{g} x \omega^2.$$

From the vector triangle shown in the figure we have

$$\tan \theta = \frac{C}{W} = \frac{x \omega^2}{g},$$

and since the slope of the surface curve is  $\frac{dy}{dx} = \tan \theta$ , we have as its differential equation

$$\frac{dy}{dx} = \tan \theta = \frac{x \omega^2}{g},$$

whence, by integration, its algebraic equation is found to be

$$y = \frac{\omega^2 x^2}{2g}. \quad (120)$$

The surface curve cut out by a diametral section is therefore a parabola with vertex in the axis of rotation, and the free surface is a paraboloid of revolution.

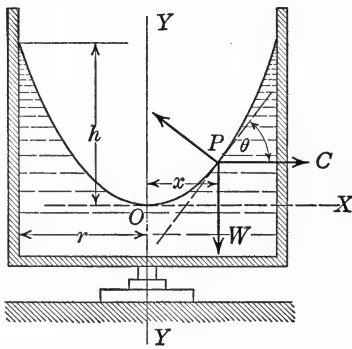

FIG. 171.

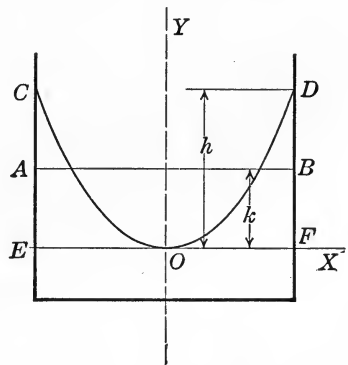

FIG. 172.

**Depression of Cup below Original Level in Open Vessel.**— Since the volume of a paraboloid is half the volume of the circumscribing cylinder, the volume of liquid above the level  $OX$  of the vertex (Fig. 172) is

$$\text{Vol. } OCDEF = \frac{\pi r^2 h}{2}.$$

But if  $AB$  is the level of the liquid when at rest, then

$$\pi r^2 k = \frac{\pi r^2 h}{2}$$

where  $k$  denotes the depth of the cup below the original level, and therefore

$$k = \frac{h}{2} = \frac{r^2 \omega^2}{4g}. \tag{121}$$

Consequently the depth of the cup below the original level is proportional to the square of the angular velocity.

**Depression of Cup below Original Level in Closed Vessel.**—If the top of the tank is closed and the angular velocity increased until the liquid presses against the top, as shown in Fig. 173, the surface will still remain a paraboloid. If the total depth of the cup is denoted by  $H$  and its greatest radius by  $R$ , then since its volume must be the same as that of the cup of depth  $h$ , we have the relation

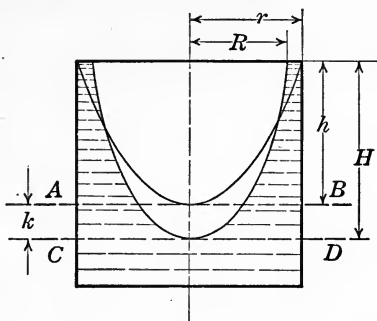

FIG. 173.

of depth  $h$ , we have the relation

$$hr^2 = HR^2$$

whence

$$R^2 = \frac{hr^2}{H}.$$

But from the equation of the surface curve,  $y = \frac{\omega^2 x^2}{2g}$ , by substituting the simultaneous values  $y = H$ ,  $x = R$ , we have

$$H = \frac{\omega^2 R^2}{2g},$$

and substituting in this relation the value of  $R^2$  from the previous equation, the result is

$$H = \frac{\omega^2 hr^2}{2gH},$$

whence

$$H = \omega r \sqrt{\frac{h}{2g}}. \tag{122}$$

Therefore after the liquid touches the top cover of the tank, the total depth of the cup is proportional to the first power of the angular velocity.

**Practical Applications.**—An important physical application of these results consists in the formation of a true parabolic mirror by placing mercury in a circular vessel which is then rotated with uniform angular velocity, the focus of the mirror depending on the speed of rotation.

Another practical application has been found in the construction of a speed indicator. A glass cylinder containing a colored liquid is mounted on a vertical spindle which is geared to the shaft whose speed is required. The required speed is then obtained by noting the position of the vertex of the paraboloid on a vertical scale. From the level  $AB$  to the level  $CD$  (Fig. 173) the graduations on the scale are at unequal distances apart, as apparent from Eq. (121), but below this point they are equidistant, as shown by Eq. (122).

### 39. WATER HAMMER IN PIPES

**Increase in Pressure due to Suddenly Checking Flow.**—If water is flowing in a pipe with uniform velocity and the flow is suddenly stopped, as by the closure of a valve, the pressure in the pipe is greatly increased. If the velocity of flow is denoted by  $v$  and the mass of water in the pipe by  $m$ , the momentum of this mass will be  $mv$ . Assuming that the pipe is rigid and the water incompressible, if the flow is stopped in a length of time  $t$ , the increased pressure  $F$  near the valve may be obtained from the principle of impulse and momentum, namely

$$Ft = mv. \quad (123)$$

From this relation it appears that if the valve is closed instantaneously, that is,  $t = 0$ , the pressure  $F$  is infinite since the right member,  $mv$ , is finite and different from zero.

**Bulk Modulus of Elasticity of Water.**—In reality, however, this result is not valid, since the pipe walls are elastic and the water compressible. Thus it has been found by experiment that a pressure of one atmosphere, or 14.7 lb. per square inch, on each face of a cube of water at 32° F. causes it to lose about 0.00005 of its original volume. Consequently the bulk modulus of elasticity of water,  $B$ , defined as

$$B = \frac{\text{unit stress}}{\text{unit volume deformation}},$$



has for its numerical value

$$B = \frac{14.7}{0.00005} = 294,000 \text{ lb. per square inch.} \quad (124)$$

**Pressure Waves in Pipe Produced by Suddenly Checking Flow.**—What actually happens when the flow in a pipe is suddenly shut off, is an increase in pressure, beginning at the valve, which compresses the water and distends the pipe. Beginning at the valve, this effect travels back toward the reservoir or supply, producing a wave of compression in the water and a wave of distortion in the pipe. When all the water in the pipe has been brought to rest, the total kinetic energy originally possessed by the flowing water is stored up in the elastic deformation of the water and pipe walls. Since this condition cannot be maintained under the actual head in the reservoir, the pipe then begins to contract and the water to expand, thereby forcing the water back into the reservoir until it acquires a velocity approximately equal to its original velocity but in the opposite direction, that is, back toward the reservoir. After this wave has traversed the pipe, the water again comes to rest, but the kinetic energy acquired by the flow toward the reservoir will have reduced the pressure below normal. Consequently water again enters the pipe from the reservoir and flows toward the valve, beginning a new cycle of operations.

**Velocity of Compression Wave.**—An expression for the velocity of the wave of compression and distortion has been deduced by Professor I. P. Church,<sup>1</sup> and is given by the formula

$$v_c = \sqrt{\frac{BE \text{ cg}}{\delta(Ec + Bd)}} \quad (125)$$

where  $v_c$  = velocity of pressure wave, in feet per second.

$B$  = bulk modulus of elasticity of water = 294,000 lb. per square inch,

$E$  = modulus of elasticity in tension of pipe material,

$c$  = thickness of pipe wall in inches,

$d$  = internal diameter of pipe in inches,

$$\delta = \frac{62.4}{144} = 0.4333.$$

**Period of Compression Wave.**—The period of the pressure

<sup>1</sup>Church: Hydraulic Motors, p. 203.

wave, or time  $T$  required for a wave to make a complete round trip from one end to the other and back again, is evidently

$$T = \frac{2l}{v_c}, \quad (126)$$

where  $l$  denotes the length of the pipe in feet.

**Increase in Pressure Produced by Instantaneous Stoppage of Flow.**—Professor Church has also derived a formula for the increase in pressure due to an instantaneous stop, namely,

$$p_{max} = \frac{\delta v v_c}{g} = v \sqrt{\frac{\delta B E a}{g(Ec + Bd)}}, \quad (127)$$

where  $v$  = velocity of flow before closure,

$p_{max}$  = increase in pressure in pounds per square inch in excess of original hydrostatic pressure.

**Joukovsky's Experiments.**—Elaborate experiments on water hammer in pipes, made by Professor Joukovsky<sup>1</sup> of Moscow, Russia, in 1897-98, confirm these theoretical results, and also show that if the time  $t$  of closure is less than the period  $T$  (Eq. (126)), the full force of the maximum pressure ( $p_{max}$ , Eq. (127)) will be felt in the pipe. But if the time  $t$  of closure is greater than the period  $T$ , the intensity of excess pressure,  $p$ , is reduced according to the relation

$$\frac{p}{p_{max}} = \frac{T}{t}; \quad (128)$$

that is, the excess pressure is inversely proportional to the time of closure.

**Gibson's Experiments.**—From more recent experiments, made by A. H. Gibson<sup>2</sup> of Manchester, England, it has been found that when the time of stoppage of flow is greater than  $2T$  or  $\frac{4l}{v_c}$ , the excess pressure  $p$  is given by the formula

$$p = \frac{\delta (la_1)}{g(ta)} \left[ \frac{la_1}{ta} + \sqrt{2gh + \left( \frac{la_1}{ta} \right)^2} \right] \quad (129)$$

where  $a$  = cross section of pipe,

$a_1$  = area through valve when closing begins,

$h$  = difference in static head in feet between the two sides of valve when there is no flow,

$t$  = time of uniform closing of valve.

<sup>1</sup> Joukovsky: Abstract by Simin; Jour. Amer. Water Works Assn., 1904, p. 335.

<sup>2</sup> Gibson: Water Hammer in Hydraulic Pipe Lines, Van Nostrand, 1909.

The best precaution against hydraulic shock of this nature has been found to be the use of slow closing valves. Air chambers placed near the valves have also been found effective if kept filled with air, and safety valves of course reduce the shock to a pressure corresponding to the strength of spring used.

#### 40. HYDRAULIC RAM

**Principle of Operation.**—A useful application of water hammer is made in the hydraulic ram. In principle, a hydraulic ram is an automatic pump by which the water hammer produced by suddenly checking a stream of running water is used to force a portion of that water to a higher elevation.

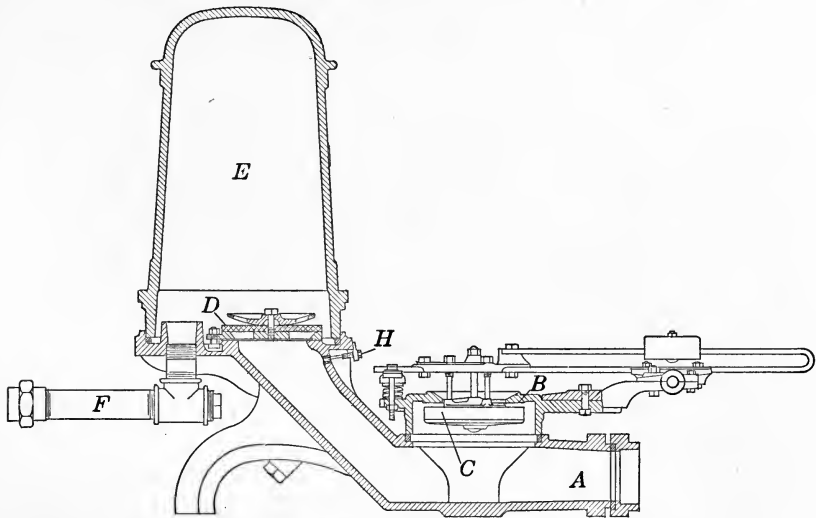

Drive Pipe Connection *A*      Discharge Pipe *F*      Air Chamber *E*  
 Escape Valve *C*      Delivery Valve *D*      Air Feeder *H*

FIG. 174.—Rife hydraulic ram.

To illustrate the method of operation, a cross section of a ram is shown in Fig. 174. The ram is located below the level of the supply water in order to obtain a flow in the drive pipe. If located some distance from the supply, the water is first conducted to a short standpipe, as shown in Fig. 175, and from here a drive pipe of smaller diameter than the supply pipe conducts the water to the ram. The object of this arrangement is to utilize the full

head of water available without making the drive pipe too long for the capacity of the ram.

Referring to Fig. 174, the water flowing in the drive pipe *A* at first escapes around the valve *C*, which is open or down. This permits the velocity of flow to increase until the pressure against *C* becomes sufficient to raise it against its seat *B*. Since the water can then no longer escape through the valve *C*, it enters the

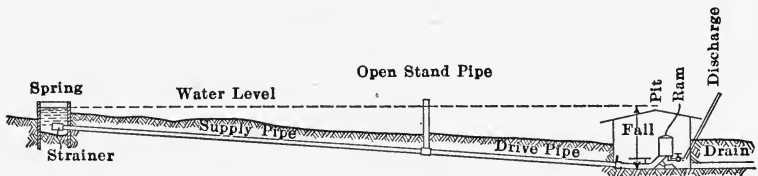

FIG. 175.

air chamber *E* through the valve *D*, thereby increasing the pressure precisely as in the case of water hammer discussed in the preceding article. When the pressure in *E* attains a certain maximum value, the flow is checked and the valve *D* falls back into place, closing the opening and trapping the water which has already entered the chamber *E*. The pressure in *E* then forces this water into the supply pipe *F*, which delivers it at an elevation proportional to the pressure in *E*.

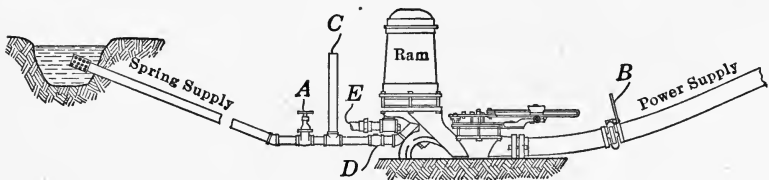

FIG. 176.

Hydraulic rams are also so built that they can be operated from one source of supply and pump water from a different source (Fig. 176). Muddy or impure water from a creek or stream may thus be used to drive a ram, and the water pumped from a pure spring to the delivery tank.

**Efficiency of Ram.**—The mechanical efficiency of a ram depends on the ratio of fall to pumping head, ranging from 20 per cent. for a ratio of 1 to 30, up to 75 per cent. for a ratio of 1 to 4.

Its efficiency as a pump is of course very small, as only a small fraction of the water flowing in the drive pipe reaches the delivery pipe. The advantages of the hydraulic ram are its small first cost, simplicity of operation, and continuous service day and night without any attention.

To obtain an expression for the mechanical efficiency of a ram, let

$H$  = supply head,

$h$  = effective delivery head including friction,

$q$  = quantity delivered,

$Q$  = quantity wasted at valve.

Then the total input of energy to the ram is  $(Q + q)H$ , and the total output is  $qh$ . Consequently the mechanical efficiency is given by the ratio

$$E = \frac{qh}{(Q + q)H}.$$

This is known as d'Aubuisson's efficiency ratio.

The hydraulic efficiency, however, is the ratio of the energy required for delivery to the energy of the supply. Consequently its value is

$$E = \frac{q(h - H)}{QH}.$$

The latter expression is known as Rankine's formula.

#### 41. DISPLACEMENT PUMPS

There are two types of pumps in general use; the displacement, or reciprocating type, and the centrifugal type. In the displacement pump the liquid is raised by means of a bucket, piston, or plunger, which reciprocates backward and forward inside a cylindrical tube called the pump barrel or cylinder. In the centrifugal pump, as its name indicates, the operation depends on the centrifugal force produced by rotation of the liquid.

**Suction Pump.**—One of the simplest forms of displacement pump is the ordinary suction pump shown in Fig. 177. Here the essential parts are a cylinder or barrel  $C$  containing a bucket  $B$ , which is simply a piston provided with a movable valve, permitting the water to pass through in one direction only. This bucket is made to reciprocate up and down inside the barrel by means of a rod  $E$ . A suction pipe  $S$  leads from the lower

end of the barrel to the liquid to be raised, and a delivery pipe  $D$  discharges the liquid at the desired elevation.

In operation, the bucket starts from its lowest position, and as it rises, the valve  $m$  closes of its own weight. The closing of this valve prevents the air from entering the space below the bucket, and consequently as the bucket rises the increase in volume below it causes the air confined in this space to expand and thereby lose in pressure. As the pressure inside the suction pipe  $S$  thus becomes less than atmospheric, the pressure outside forces some of the liquid up into the lower end of the pipe.

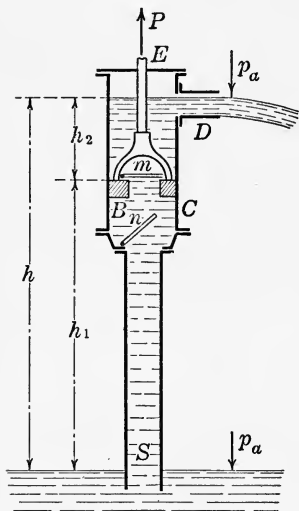

FIG. 177.

When the bucket reaches the top of its stroke and starts to descend, the valve  $n$  closes, trapping the liquid already in the suction pipe  $S$  and also that in the barrel, thereby lifting the valve  $m$  as the bucket descends. When the bucket reaches its lowest position, it again rises, repeating the whole cycle of operations. At each repetition the water rises higher as it replaces the air, until finally it fills the pump and a continuous flow is set up through the delivery pipe.

**Maximum Suction Lift.**—Since atmospheric pressure at sea level is 14.7 lb. per square inch, a pump operating by suction alone cannot raise water to a height greater than the head corresponding to this pressure. Since a cubic foot of water weighs 62.4 lb., the head corresponding to a pressure of one atmosphere is

$$h = \frac{14.7}{\frac{62.4}{144}} = \frac{14.7}{0.434} = 33.95 \text{ ft.},$$

which is therefore the maximum theoretical height to which water can be lifted by suction alone. As there are frictional and other losses to be considered, the actual suction lift of pumps is only about two-thirds of this amount, the practical lift for different attitudes and pressures being as given in the following table.

Altitude	Barometric pressure	Equivalent head of water	Practical suction lift of pumps
Sea level....	14.70 lb. per sq. in.	33.95 ft.	22 ft.
1/4 mile...	14.02 lb. per sq. in.	32.38 ft.	21 ft.
1/2 mile...	13.33 lb. per sq. in.	30.79 ft.	20 ft.
3/4 mile...	12.66 lb. per sq. in.	29.24 ft.	18 ft.
1 mile.....	12.02 lb. per sq. in.	27.76 ft.	17 ft.
1-1/4 miles.	11.42 lb. per sq. in.	26.38 ft.	16 ft.
1-1/2 miles.	10.88 lb. per sq. in.	25.13 ft.	15 ft.
2 miles....	9.88 lb. per sq. in.	22.82 ft.	14 ft.

**Force Pump.**—When it is necessary to pump a liquid to a height greater than the suction lift, or when it is desired to equalize the work between the up and down strokes, a combination suction and force pump may be used, as shown in Fig. 178. In the simple type here illustrated, the bucket is replaced by a solid piston, the movable valves being at *m* and *n* as shown. On the up stroke of the piston the valve *m* closes and the pump operates like a simple suction pump, filling the barrel with liquid. When the piston starts to descend, the valve *n* closes, and the liquid in the barrel is therefore forced out through the valve *m* into the delivery pipe *D*.

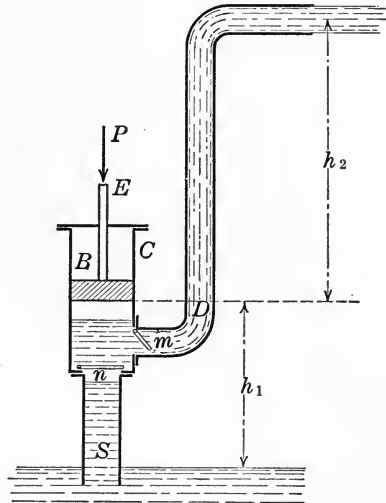

FIG. 178.

By making the suction and pressure heads equal, the piston can therefore be made to do the same amount of work on the down as on the up stroke; or the entire suction head may be utilized and the pressure head made whatever may be necessary.

**Stress in Pump Rod.**—To find the pull *P* on the pump rod *E* for the type shown in Fig. 177, let *A* denote the area of the bucket and *h*<sub>1</sub>, *h*<sub>2</sub>, the heads above and below the bucket, as indicated in the figure. Then the downward pressure *P*<sub>1</sub> on top of the bucket is

$$P_1 = 14.7A + 62.4h_2A,$$

and the upward pressure  $P_2$  on the bottom of the bucket is

$$P_2 = 14.7A - 62.4h_1A.$$

Therefore the total pull  $P$  in the rod is

$$P = P_1 - P_2 = 62.4A(h_1 + h_2) = 62.4Ah.$$

If  $l$  denotes the length of the stroke, the work done per stroke is then

$$\text{work per stroke} = Pl = 62.4Ahl.$$

For the combined suction and pressure type shown in Fig. 178, the pressure in the rod on the down stroke is

$$P = 62.4Ah_2,$$

and the tension in the rod on the up stroke is

$$P = 62.4Ah_1.$$

**Direct Driven Steam Pump.**—The modern form of reciprocating power pump of the suction and pressure type is the

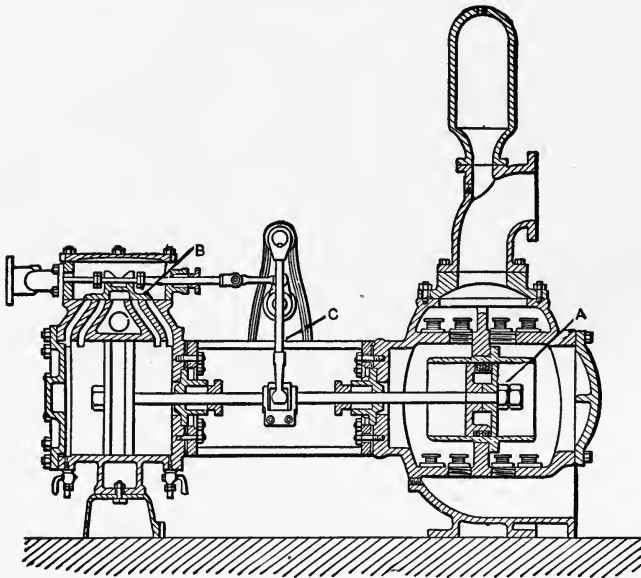

FIG. 179.

direct driven steam pump, illustrated in Figs. 179 and 180. In this type the steam and water pistons are on opposite ends of the same piston rod and therefore both have the same stroke, although their diameters are usually different. Until recently this was the standard type of general service pump, being used



for all pressures and capacities, from boiler feed pumps to municipal pumping plants. Although the centrifugal type is rapidly taking its place for all classes of service, the displacement pump is the most efficient where conditions demand small capacity at a high pressure, as in the operation of hydraulic machinery. Fig. 181 illustrates the use of a displacement pump in connection with a hydraulic press. The best layout in this case would be

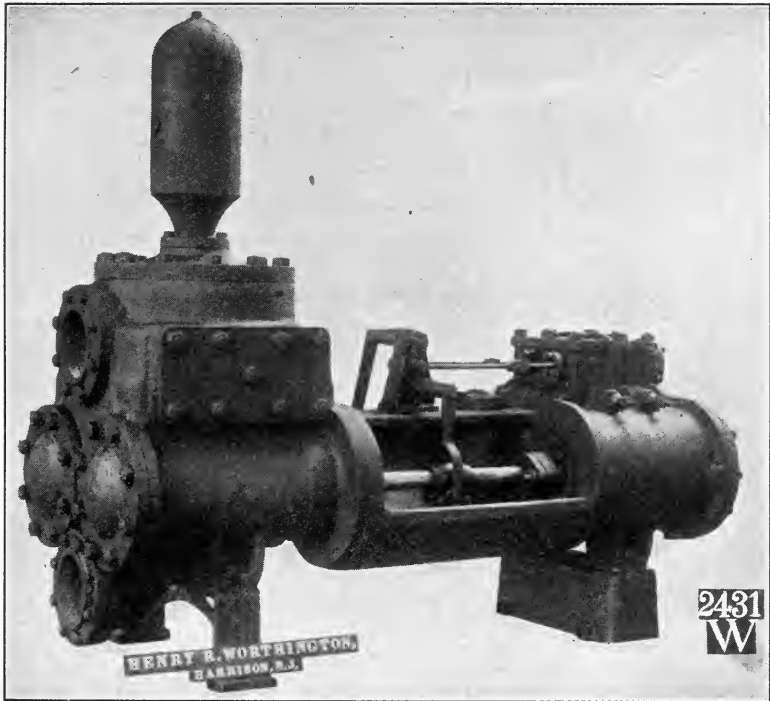

FIG. 180.

to use a high-pressure pump and place an accumulator (Art. 3) in the discharge line between pump and press. The press cylinder can then be filled immediately at the maximum pressure and the ram raised at its greatest speed, the pump running meanwhile at a normal speed and storing excess power in the accumulator.

**Calculation of Pump Sizes.**—To illustrate the calculation of pump sizes, suppose it is required to find the proper size for a duplex (*i.e.*, two cylinder, Fig. 180) boiler feed pump to supply a 100-H.P. boiler.

For large boilers the required capacity may be figured as 34-1/4 lb. of water evaporated per hour per horse power. For small boilers it is customary to take a larger figure, a safe practical rule being to assume 1/10 of a gallon per minute per boiler horse power.

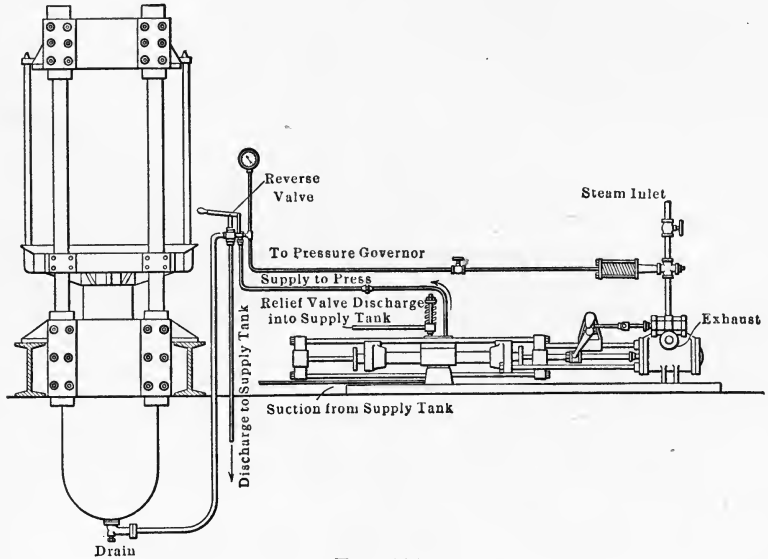

FIG. 181.

In the present case, therefore, a 100-H.P. boiler would require a supply of 10 gal. per minute. Assuming 40 strokes per minute as the limit for boiler feed pumps, the required capacity is

$$\frac{10}{40} = 0.25 \text{ gal. per stroke.}$$

Therefore, assuming the efficiency of the pump as 50 per cent., the total capacity of the pump per stroke should be

$$\frac{0.25}{0.50} = 0.5 \text{ gal. per stroke.}$$

Since we are figuring on a duplex, or two cylinder, pump, the required capacity per cylinder is

$$\frac{0.5}{2} = 0.25 \text{ gal. per stroke per cylinder,}$$

and consequently the displacement per stroke on each side of the piston must be

$$\frac{0.25}{2} = 0.125 \text{ gal. piston displacement.}$$

Referring to Table 7 it is found that a pump having a water cylinder 2-3/4 in. in diameter, with a 5-in. stroke, will have the required capacity.

**Power Required for Operation.**—To find expressions for the H.P. and steam pressure required to operate a displacement pump, let

- $Q$  = discharge of pump in gal. per minute,  
 $h$  = total pumping head in feet (including friction and suction head if any),  
 $D$  = diameter of steam piston in inches,  
 $d$  = diameter of water piston in inches,  
 $p$  = steam pressure in pounds per square inch,  
 $w$  = water pressure in pounds per square inch,  
 $n$  = number of full strokes (*i.e.*, round trips) per minute,  
 $c$  = number of pump cylinders (*e.g.*, for duplex pump, Fig. 180,  $c = 2$ ),  
 $l$  = length of stroke in inches,  
 $E$  = efficiency of pump.

Since a gallon of water weighs 8.328 lb., the total work per minute required to raise the given amount  $Q$  to the height  $h$  is

$$\text{work} = 8.328Qh \text{ ft.-lb. per minute.}$$

Taking into account the efficiency of the pump, the actual horse power required is therefore

$$\text{H.P.} = \frac{8.328 Qh}{33000 E} = 0.00025 \frac{Qh}{E}. \quad (130)$$

**Diameter of Pump Cylinder.**—If the pump makes  $n$  full strokes per minute, the piston displacement per minute for each cylinder is

$$2n \left( \frac{\pi d^2}{4} l \right),$$

and the actual effective displacement of the pump per minute is

$$\text{effective displacement} = 2ncE \left( \frac{\pi d^2}{4} l \right) \text{ cu. in. per minute.}$$

Equating this to the required discharge  $Q$ , expressed in cubic inches per minute, we have

$$2ncE \left( \frac{\pi d^2}{4} l \right) = 231Q,$$

whence the required diameter of the pump cylinder in terms of the speed is found to be

$$d = \sqrt{\frac{2 \times 231Q}{\pi \ln c E}} = 12.13 \sqrt{\frac{Q}{\ln c E}}. \quad (131)$$

**Steam Pressure Required for Operation.**—Since the total pressure on the steam piston cannot be less than that on the water piston, the minimum required steam pressure,  $p$ , is given by the relation

$$p \left( \frac{\pi D^2}{4} \right) = 0.434h \left( \frac{\pi d^2}{4} \right),$$

whence

$$p = 0.434h \left( \frac{d}{D} \right)^2. \quad (132)$$

**Numerical Application.**—To illustrate the application of these results, suppose it is required to determine the indicated horse power to operate a fire engine which delivers two streams of 250 gal. per minute each, to an effective height of 60 ft.

Since the height of an effective fire stream is approximately four-fifths that of the highest drops in still air, the required head at the nozzle is

$$\frac{5}{4}h = \frac{5}{4} \times 60 = 75 \text{ ft.}$$

To this must be added the friction head  $h_f$  lost in the hose between pump and nozzle, which is given by the relation (Art. 17)

$$h_f = f \frac{l}{d} \frac{v^2}{2g},$$

where  $l$  is the length of the hose and  $d$  its diameter, both expressed in inches,  $v$  is the velocity of flow through the hose, and  $f$  is an empirical constant. For the best rubber lined hose,  $f = 0.02$  for the first 100 ft. of hose and 0.0025 for each additional 100 ft. whereas for unlined hose  $f = 0.04$  for the first 100 ft. and 0.005 for each additional 100 ft. In the present case, assuming 100 ft. of the best 2-1/2-inch rubber-lined hose, we have  $f = 0.02$ , and since the quantity of water delivered is

$$Q = 250 \times \frac{231}{1728} \text{ cu. ft. per minute,}$$

and the area of the hose is

$$A = \frac{\pi d^2}{4} = \frac{\pi(2.5)^2}{4} = 4.908 \text{ sq. in.,}$$

the velocity of flow in the hose is

$$v = \frac{Q}{\frac{A}{144} \times 60} = 16.3 \text{ ft. per second.}$$

Consequently the friction head  $h_f$  is

$$h_f = 0.02 \frac{1200}{2.5} \frac{(16.3)^2}{64.4} = 39.6, \text{ say } 40 \text{ ft.,}$$

and therefore the total pumping head  $H$  is

$$H = 75 + 40 = 115 \text{ ft.}$$

From Eq. (130) the total horse power required, assuming a pump efficiency of 50 per cent., is then found to be

$$\text{H.P.} = 0.00025 \frac{500 \times 115}{0.50} = 28.75.$$

Assuming the efficiency of the engine to be 60 per cent., the total indicated horse power required would be

$$\text{I.H.P.} = \frac{28.75}{0.60} = 48.$$

#### 42. CENTRIFUGAL PUMPS

**Historical Development.**—The centrifugal pump in its modern form is a development of the last 15 years although as a type it is by no means new. The inventor of the centrifugal pump was the celebrated French engineer Denis Papin, who brought out the first pump of this type in Hesse, Germany, in 1703. Another was designed by Euler in 1754. These were regarded as curiosities rather than practical machines until the type known as the Massachusetts pump was produced in the United States in 1818. From this time on, gradual improvements were made in the centrifugal pump, the most important being due to Andrews in 1839, Bessemer in 1845, Appold in 1848, and John and Henry Gynne in England in 1851. Experiments seemed to show that the best efficiency obtainable from pumps of this type ranged from 46 to 64 per cent. under heads varying from 4-1/2 to 15 ft., and 40 ft. was considered the maximum head for practical operation.

About the year 1901 it was shown that the centrifugal pump was simply a water turbine reversed, and when designed on similar lines was capable of handling heads as large, with an efficiency as

high, as can be obtained from the turbines themselves. Since this date, great progress has been made in both design and construction, the efficiency of centrifugal pumps now ranging from 55 to over 90 per cent., and it being possible to handle heads as high as 300 ft. with a single stage-turbine pump and practically any head with a multi-stage type.<sup>1</sup>

The advantages of the centrifugal over the displacement type are its greater smoothness of operation, freedom from water hammer or shock, absence of valves, simplicity and compactness, and its adaptability for driving by belt or by direct connection to modern high-speed prime movers, such as steam turbines and electric motors. Under favorable conditions the first cost of a high-lift centrifugal pump may be as low as one-third that of a displacement pump, and the floor space occupied one-fourth that required by the latter. However, for small quantities of water discharged under a high head the displacement pump is preferable to the centrifugal type, as the latter requires too much compounding under such conditions.

**Principle of Operation.**—The principle on which the original centrifugal pumps of Papin and Euler operated was simply that when water is set in rotation by a paddle wheel, the centrifugal force created forces the water outward from the center of rotation. Appold discovered that the efficiency depended chiefly on the form of the blade of the rotary paddle wheel, or impeller, and the shape of the enveloping case, and that the best form for the blade was a curved surface opening in the opposite direction to that in which the impeller revolved, and for the case was a spiral form or volute. The first engineer to discover the value of compounding, that is, leading the discharge of one centrifugal pump into the suction of another similar pump, was the Swiss engineer Sulzer of Winterthur, who was closely followed by A. C. E. Rateau of Paris, France, and John Richards and Byron Jackson of San Francisco, California.

In its modern form, the power applied to the shaft of a centrifugal pump by the prime mover is transmitted to the water by means of a series of curved vanes radiating outward from the center and mounted together so as to form a single member called

<sup>1</sup> Rateau found by experiment that with a single impeller 3.15 in. in diameter, rotating at a speed of 18,000 r.p.m., it was possible to attain a head of 863 ft. with an efficiency of approximately 60 per cent. Engineer, Mar. 7, 1902.

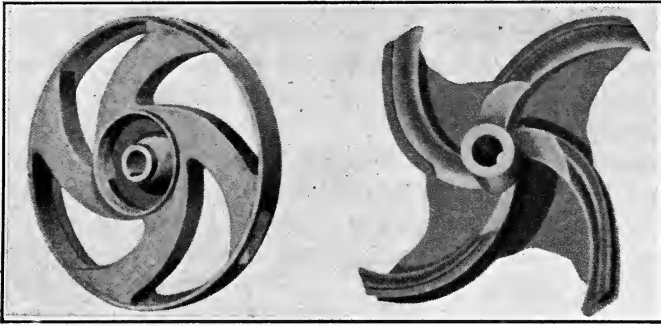

Hollow arm impeller.

Concave arm impeller.

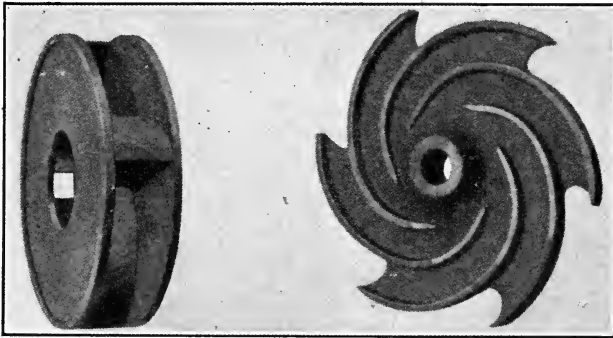

Sand pump impeller.

Open impeller used in sewage pumps.

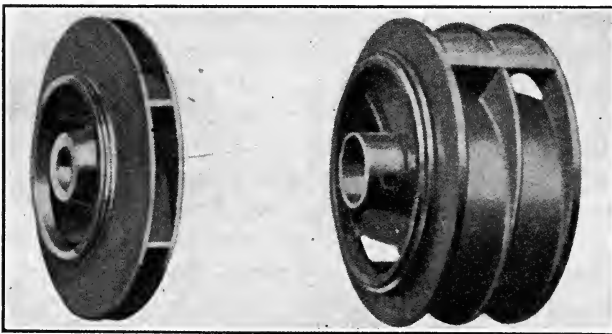

Enclosed side suction impeller.

Enclosed double suction impeller.

FIG. 182.—Impeller types. (Courtesy Morris Machine Works.)

the *impeller* (Fig. 182). The water is picked up at the inner edges of the impeller vanes and rapidly accelerated as it flows between them, until when it reaches the outer circumference of the impeller it has absorbed practically all the energy applied to the shaft.

**Impeller Types.**—There are two general forms of impeller, the open and the closed types. In the former the vanes are attached to a central hub but are open at the sides, revolving between two stationary side plates. In the closed type, the

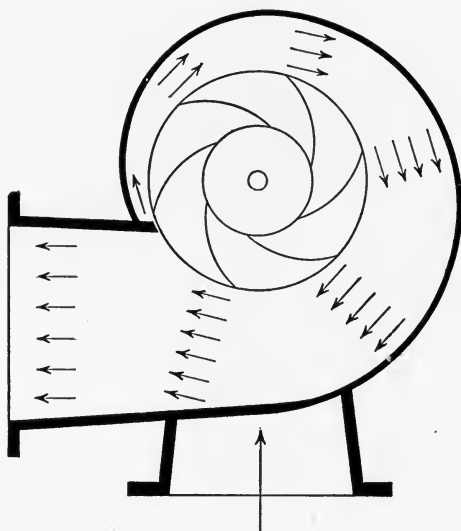

FIG. 183.

vanes are formed between two circular disks forming part of the impeller, thus forming closed passages between the vanes, extending from the inlet opening to the outer periphery of the impeller. The friction loss with an open impeller is considerably more than with one of the closed type, and consequently the design of pumps of high efficiency is limited to the latter.

**Conversion of Kinetic Energy into Pressure.**—As the water leaves the impeller with a high velocity, its kinetic energy forms a considerable part of the total energy and the efficiency of the pump therefore depends largely on the extent to which this kinetic energy is converted into pressure in the pump casing.

In some forms of pump no attempt is made to utilize this kinetic energy, the water simply discharging into a concentric



chamber surrounding the impeller, from which it flows into a discharge pipe. The result of such an arrangement is that only the pressure generated in the impeller is utilized and all the kinetic energy of the discharge is dissipated in shock and eddy formation.

**Volute Casing.**—This loss of kinetic energy may be partially avoided by making the casing spiral in section, so that the sectional area of the discharge passage increases uniformly,

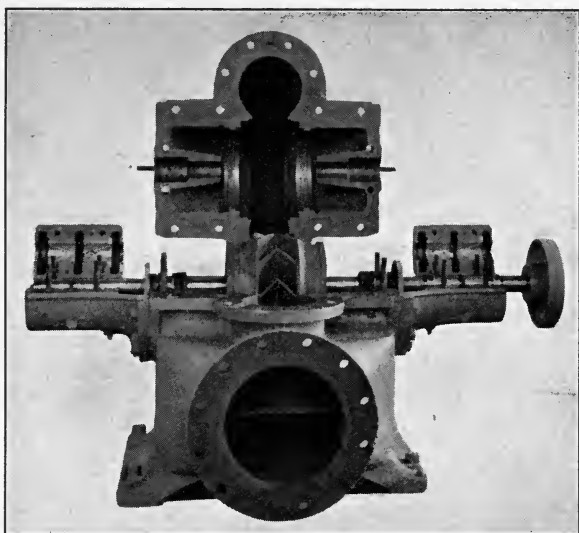

FIG. 184.—Double suction volute pump, built by the Platt Iron Works Co.

making the velocity of flow constant (Fig. 183). This type of casing is called a volute chamber (Fig. 184).

When the volute is properly designed, a high efficiency may be obtained with this type of casing.<sup>1</sup>

**Vortex Chamber.**—An improvement on the simple volute chamber is that known as the whirlpool chamber, or vortex chamber, suggested by Professor James Thomson. In this type the impeller discharges into a concentric chamber considerably larger than the impeller, outside of and encircling which is a volute chamber. In its original form this necessitated exces-

<sup>1</sup> With the De Laval volute type of centrifugal pump shown in Fig. 185, efficiencies as high as 85 per cent. have been obtained under favorable conditions.

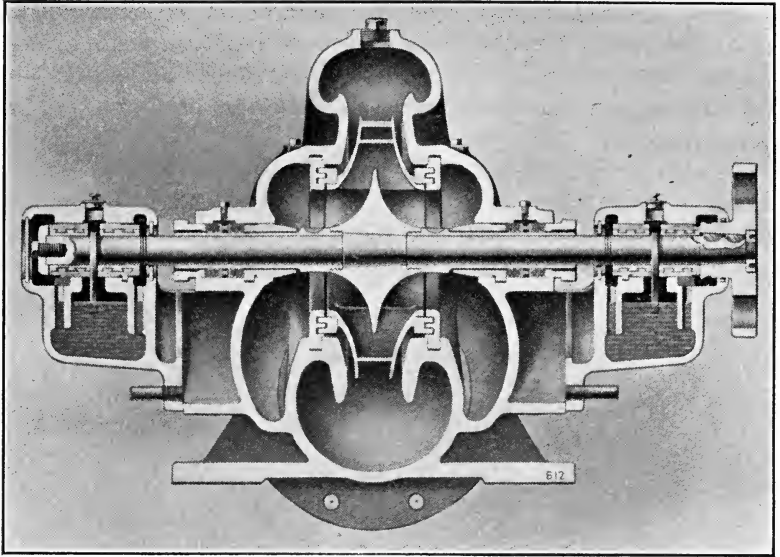

FIG. 185.—Longitudinal section of De Laval single-stage double-suction volute pump.

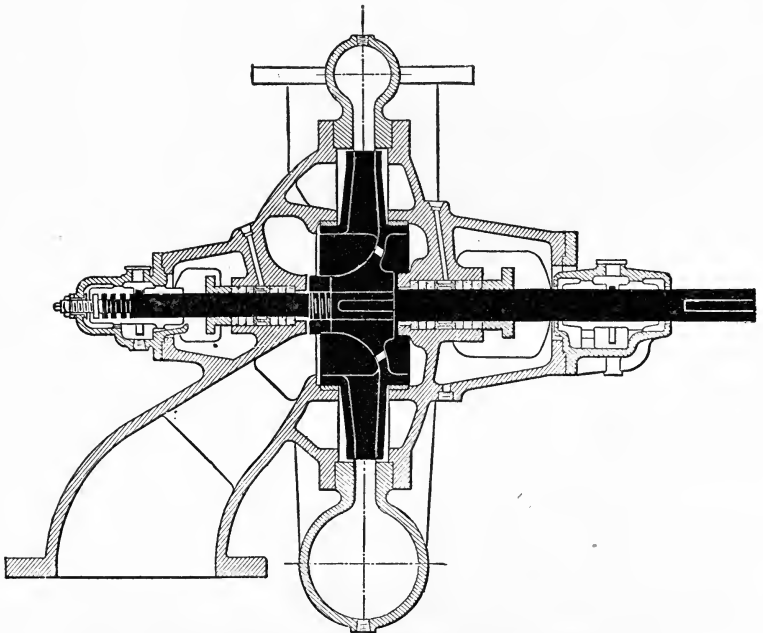

FIG. 186.—Longitudinal section of Alberger volute pump.

sively large dimensions, but in a modified form it is now very generally used (Figs. 185 and 186).

The effectiveness of this arrangement depends on the principle of the conservation of angular momentum. Thus, after the water leaves the impeller no turning moment is exerted on it (neglecting frictional resistance) and consequently as a given mass of water moves outward, its speed decreases to such an extent as to keep its angular momentum constant. For a well-designed vortex chamber, the velocity of the water at the outside

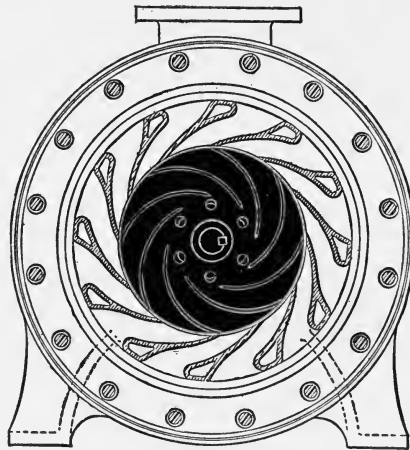

FIG. 187.—Diffusion vanes.

of the diffusion space is less than the velocity of the water as it leaves the impeller in the inverse ratio of the radii of these points, and if this ratio is large, a large part of the kinetic energy of the discharge may therefore be converted into pressure head in this manner. This method of diffusion is therefore well adapted to the small impellers of high speed pumps, since the ratio of the outer radius of the diffusion chamber to the outer radius of the impeller may be made large without unduly increasing the size of the casing.

**Diffusion Vanes.**—Another method for converting the kinetic energy of discharge into pressure head consists in an application

of Bernoulli's law as illustrated in the Venturi tube; namely, that if a stream flows through a diverging pipe the initial velocity head is gradually converted into pressure head without appreciable



END SECTIONAL VIEW

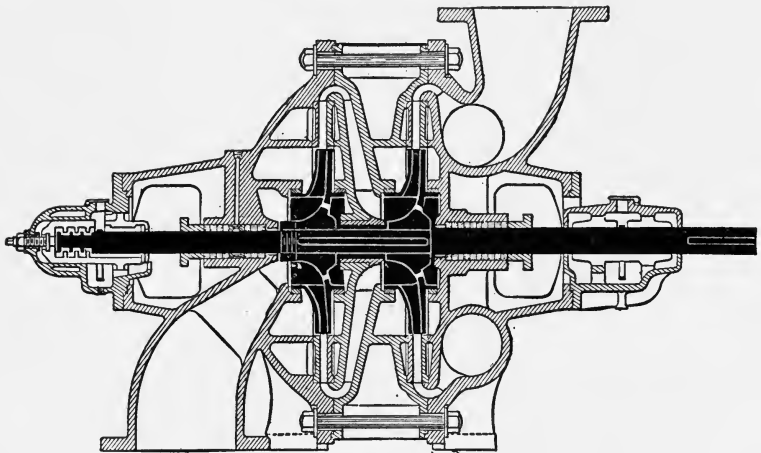

SIDE SECTIONAL VIEW

FIG. 188.—Alberger turbine pump.

loss. To apply this principle to a centrifugal pump, the impeller is surrounded by stationary guide vanes, or *diffusion vanes* (Fig. 187), so designed as to receive the water without shock on leaving the impeller and conduct it by gradually diverging passages into a vortex chamber or volute casing. This type of

construction is therefore essentially a reversed turbine, and is commonly known as a *turbine pump* (Fig. 188).

The angle which the inner tips of the diffusion vanes make with the tangents to the discharge circle is calculated exactly as in the case of the inlet vanes of a turbine, that is, so that they shall be parallel to the path of the water as it leaves the impeller. As this angle changes with the speed, the angle which is correct for one speed is incorrect for any other and may actually obstruct the discharge. A turbine pump must therefore be designed for a particular speed and discharge, and when required to work under variable conditions loses considerably in efficiency. If the conditions are very variable, the vortex chamber type is preferable, both by reason of its greater average efficiency under such conditions and also on account of its greater simplicity and cheapness of construction.

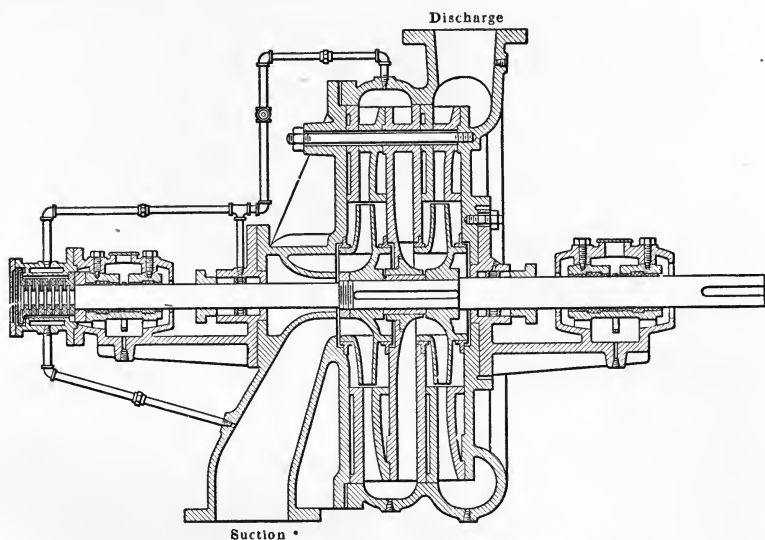

FIG. 189.—Worthington multi-stage turbine pump.

**Stage Pumps.**—Single impellers can operate efficiently against heads of several hundred feet, but for practical reasons it is desirable that the head generated by a single impeller should not exceed about 200 feet. When high heads are to be handled, therefore, it is customary to mount two or more impellers on the same shaft within a casing so constructed that the water flows successively from the discharge of one impeller into the suction

of the next. Such an arrangement is called a *stage pump*, and each impeller, or stage, raises the pressure an equal amount. Fig. 189 shows a multi-stage pump of the turbine type and Fig. 190 one of the volute type.

A single impeller pump may be either of the side suction or double suction type. In the latter, half of the flow is received on each side of the impeller which is therefore perfectly balanced

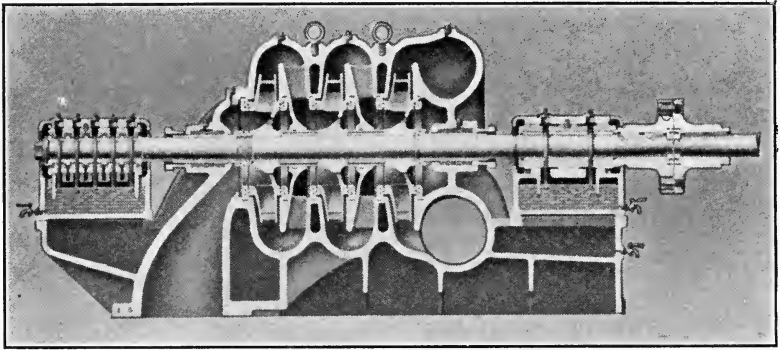

FIG. 190.—De Laval multi-stage volute pump.

against end thrust (Fig. 185). A side suction pump, however, is simpler in construction, and it is also possible to balance them hydraulically against end thrust (Fig. 186). In stage pumps the device sometimes used for balancing is to arrange the impellers in pairs so that the end thrust of one impeller is balanced by the equal and opposite end thrust of its mate.

#### 43. PRESSURE DEVELOPED IN CENTRIFUGAL PUMP

**Pressure Developed in Impeller.**—The pressure produced in a centrifugal pump must be sufficient to balance the static and frictional heads. When there is no volute, vortex chamber or diffuser, the kinetic energy of the discharge is all dissipated and the entire change in pressure is produced in the impeller. If, however, the velocity of discharge is gradually reduced by means of one of these devices, a further increase in pressure is produced in the casing or diffusion space, and if a diverging discharge pipe is used the pressure is still further increased.

The change in pressure which is produced in passing through the impeller may be deduced by applying Bernoulli's theorem. For this purpose it is convenient to separate the total difference

in pressure between the inlet and discharge circles into two components; one due to the rotation of the water in a forced vortex with angular velocity  $\omega$ , and the other due to the outward flow,

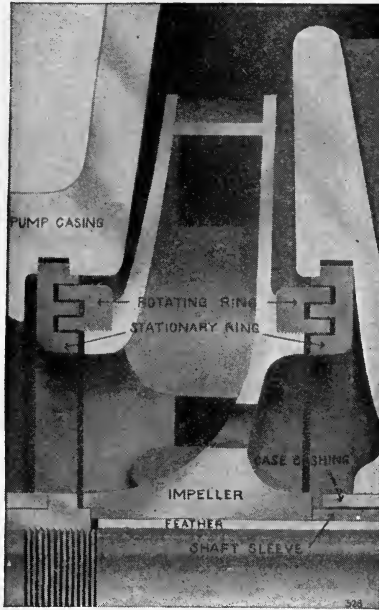

FIG. 191.—Detail of labyrinth rings in pump shown in Fig. 190.

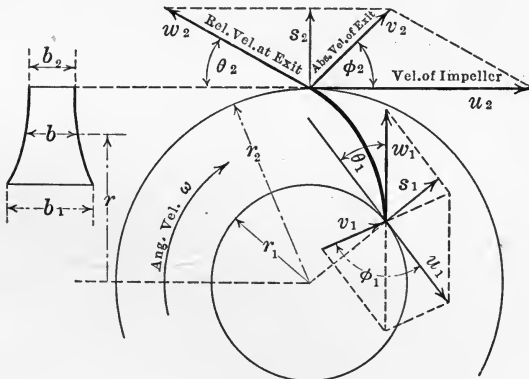

FIG. 192.

*i.e.*, the relative motion of the water with respect to the vanes of the impeller. Let the subscripts 1 and 2 refer to points on the inlet and discharge circles respectively. Then the radii of

these circles will be denoted by  $r_1, r_2$ ; the pressure at any point on these circles by  $p_1, p_2$ , etc. Also let  $\omega$  denote the angular velocity of rotation of the impeller, and  $u_1, u_2$  the tangential velocities of the vanes at their inner and outer ends (Fig. 192), in which case  $u_1 = r_1\omega$  and  $u_2 = r_2\omega$ .

Applying Bernoulli's theorem to the change in pressure produced by rotation alone, we have therefore

$$\frac{p_1}{\gamma} - \frac{\omega^2 r_1^2}{2g} = \frac{p_2}{\gamma} - \frac{\omega^2 r_2^2}{2g}.$$

Consequently the total change in pressure due to rotation, say  $p_r$  where  $p_r = p_2 - p_1$ , is given by the relation

$$\frac{p_r}{\gamma} = \frac{p_2 - p_1}{\gamma} = \frac{\omega^2}{2g}(r_2^2 - r_1^2) = \frac{u_2^2 - u_1^2}{2g}.$$

This expression is often called the *centrifugal head*.

By similar reasoning the change in pressure produced by the outward flow is given by the relation

$$\frac{p'_1}{\gamma} + \frac{w_1^2}{2g} = \frac{p'_2}{\gamma} + \frac{w_2^2}{2g},$$

whence

$$\frac{p'_2 - p'_1}{\gamma} = \frac{w_1^2 - w_2^2}{2g}.$$

If the water enters radially,  $\phi_1 = 90^\circ$  and consequently  $w_1^2 = v_1^2 + u_1^2$ . In this case, denoting the difference in pressure at inlet and exit due to the flow by  $p_f$ , where  $p_f = p'_2 - p'_1$ , we have

$$\frac{p_f}{\gamma} = \frac{p'_2 - p'_1}{\gamma} = \frac{v_1^2 + u_1^2 - w_2^2}{2g}.$$

The total increase in pressure in the impeller between the inlet and discharge ends of the vanes is therefore given by the relation

$$\frac{p_r + p_f}{\gamma} = \frac{v_1^2 + u_1^2 - w_2^2 + u_2^2 - u_1^2}{2g} = \frac{v_1^2 + u_2^2 - w_2^2}{2g}.$$

**Pressure Developed in Diffusor.**—Besides the increase in pressure produced in the impeller, the use of a suitable diffusion chamber permits part of the kinetic energy at exit, due to the absolute velocity  $v_2$  of the discharge from the impeller, to be converted into pressure. Thus if  $k$  denotes the fraction of this kinetic energy which is converted into pressure in the diffusor,



the expression derived above is increased by the term  $k\frac{v_2^2}{2g}$ . When diffusion vanes are used, as in a turbine pump, the value of  $k$  may be as high as 0.75, and for a vortex chamber it may reach 0.60.

**General Formula for Pressure Head Developed.**—Combining the terms derived above, the total pressure head  $H$  developed by the pump is given by the simple formula

$$H = \frac{kv_2^2 + v_1^2 + u_2^2 - w_2^2}{2g}. \quad (133)$$

In applying this formula it is convenient to note that the total head  $H$  developed in the pump consists of three terms, as follows:

$$\begin{aligned} \frac{v_1^2}{2g} &= \text{head at eye (entrance) of impeller;} \\ \frac{u_2^2 - w_2^2}{2g} &= \text{head developed in impeller;} \\ \frac{kv_2^2}{2g} &= \text{head developed in casing or diffusor.} \end{aligned}$$

#### 44. CENTRIFUGAL PUMP CHARACTERISTICS

**Effect of Impeller Design on Operation.**—The greatest source of loss in a centrifugal pump is that due to the loss of the kinetic energy of the discharge. As only part of this kinetic energy can be recovered at most, it is desirable to reduce the velocity of discharge to as low a value as is compatible with efficiency in other directions. This may be accomplished by curving the outer tips of the impeller vanes backward so as to make the discharge angle less than  $90^\circ$ . The relative velocity of water and vane at exit has then a tangential component acting in the opposite direction to the peripheral velocity of the impeller, which therefore reduces the absolute velocity of discharge. This is apparent from Fig. 193 in which the parallelogram of velocities in each of the three cases is drawn for the same peripheral velocity  $u_2$  and radial velocity at exit  $w_2 \sin \theta_2$ . A comparison of these diagrams indicates how the absolute velocity at exit  $v_2$  increases as the angle  $\theta_2$  increases. The backward curvature of the vanes also gives the passages a more uniform cross section, which is favorable to efficiency.

The effect which the design of the impeller has on the operation of the pump is most easily illustrated and understood by plotting

curves showing the relations between the variables under consideration. Assuming the speed to be constant, which is the usual condition of operation, three curves are necessary to completely illustrate the operation of the pump; one showing the relation between capacity and head, one between capacity and

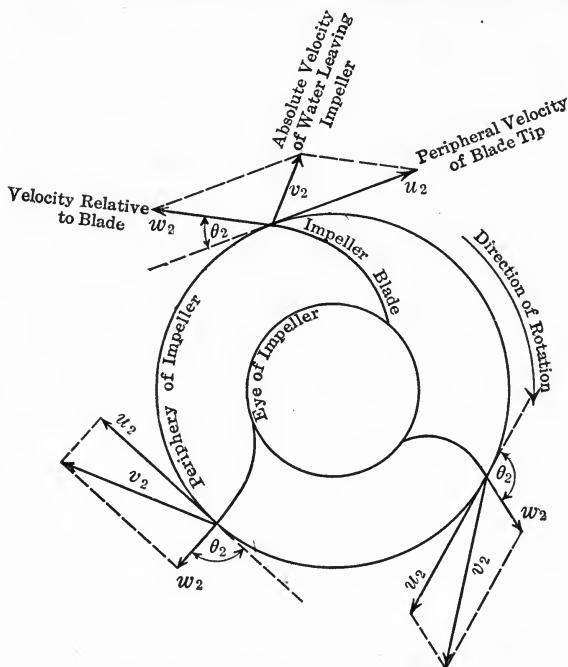

FIG. 193.

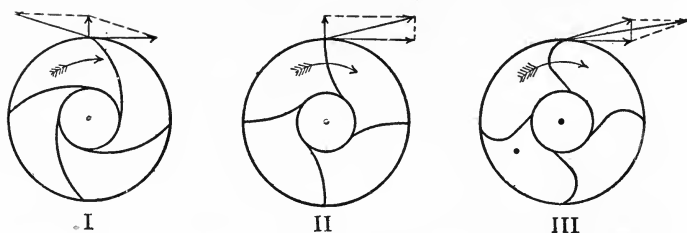

FIG. 194.

power, and one between capacity and efficiency. The first of these curves is usually termed the *characteristic*.

**Rising and Drooping Characteristics.**—The principal factor influencing the shape of the characteristic is the direction of the

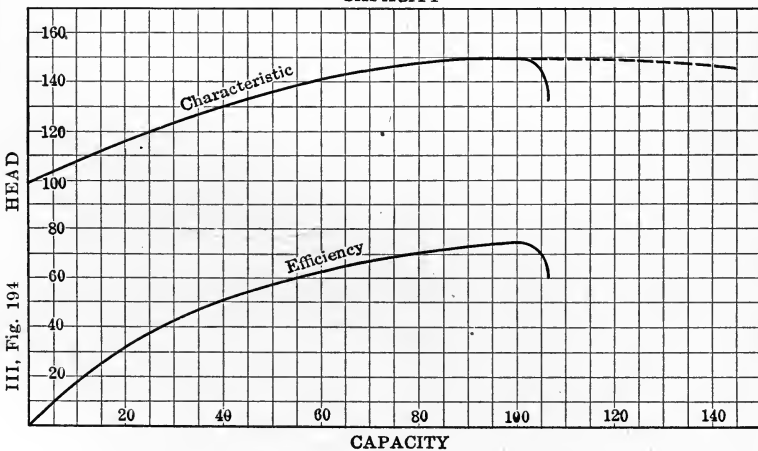
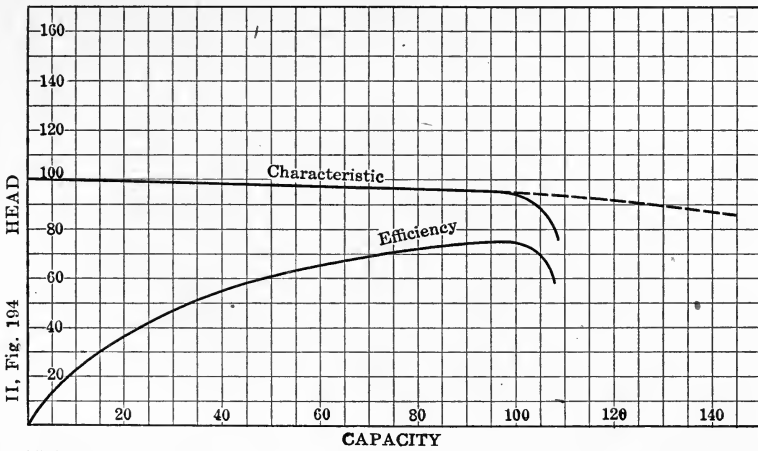
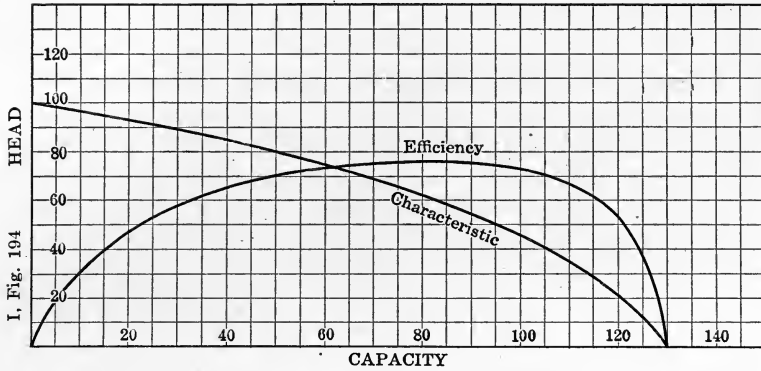

FIG. 195.—Characteristics and efficiency curves obtained with DeLaval pumps.

tips of the impeller blades at exit, although there are other factors which affect this somewhat. If the tips are curved forward in the direction of rotation the characteristic tends to be of the rising type, whereas if they curve backward the characteristic tends to be of the drooping type (Figs. 194 and 195). For a rising characteristic the head increases as the delivery increases and consequently the power curve also rises, since a greater discharge against a higher head necessarily requires more power (Fig. 196). A drooping power curve may be obtained by throttling at the eye of the impeller, but a greater efficiency results from designing the impeller so as to give this form of curve normally.

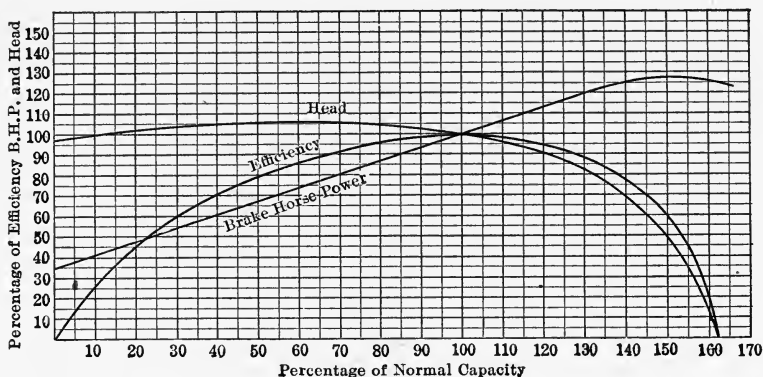

FIG. 196.

For a high lift pump under an approximately constant head, as in the case of elevator work, a pump with radial vanes is most suitable as the discharge may be varied with a small alteration in delivery head. This is also true for a pump working under a falling head, as in the case of emptying a lock or dry dock, as it makes it possible to obtain a large increase in the discharge as the head diminishes, thereby saving time although at a loss of efficiency.

One of the most important advantages of a drooping characteristic (Fig. 197) is that it is favorable to a drooping power delivery curve, making it impossible for the pump to overload the driving motor. For an electrically driven pump, in which the overload is limited to 20 per cent., or at most 25 per cent., of the normal power, backward curved vanes are therefore essential. Moreover, with a pump designed initially to work against a

certain head, if the vanes at exit are radial, or curved forward, the possible diminution in speed is very small, the discharge ceasing altogether when the speed falls slightly below normal. As the backward curvature of the vanes increases the range of speed also increases, and consequently when the actual working head is not constant, as in irrigation at different levels, or in delivering cooling water to jet condensers in low head work, where the level of the intake varies considerably, a pump with drooping characteristic is much better adapted to meet varying conditions without serious loss of efficiency.

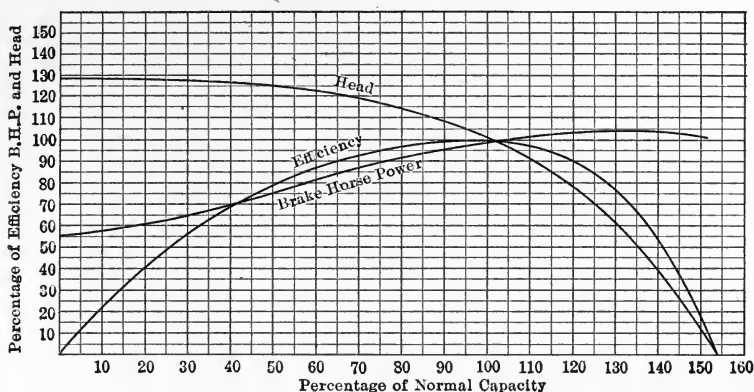

FIG. 197.

**Head Developed by Pump.**—These facts may be made more apparent by the use of the expression for the head developed by the pump, derived in the preceding article. Considering only the head developed in the impeller and casing, and omitting that due to the velocity of flow at entrance,  $v_1$ , which does not depend on the design of the pump, the expression for the head developed is

$$H = \frac{kv_2^2 + u_2^2 - w_2^2}{2g}.$$

Since  $v_2$  is the geometric resultant of  $u_2$  and  $w_2$ , we have by the law of cosines,

$$v_2^2 = u_2^2 + w_2^2 - 2u_2w_2 \cos \theta_2.$$

For an ideal pump, that is, one in which all the velocity head  $\frac{v_2^2}{2g}$  is converted into pressure head in the diffusor,  $k$  is unity. As-

suming  $k = 1$  and substituting the expression for  $v_2^2$  in the equation for  $H$ , the result is

$$H = \frac{u_2^2 - u_2 w_2 \cos \theta_2}{g}$$

For constant speed of rotation,  $u_2$  is constant.

For forward curved vanes  $\theta_2$  is greater than  $90^\circ$  and therefore  $\cos \theta_2$  is negative. In this case as  $w_2$  increases  $H$  also increases; *i.e.*, the greater the delivery the greater the head developed.

For radial tipped vanes,  $\theta_2 = 90^\circ$  and  $\cos \theta_2 = 0$ . In this case  $H = \frac{u_2^2}{g}$ , which is constant for all deliveries.

For backward curved vanes  $\theta_2$  is less than  $90^\circ$  and  $\cos \theta_2$  is positive. Consequently in this case as the delivery increases the head diminishes.

Although these relations are based on the assumption of a perfect pump, they serve to approximately indicate actual conditions, as is evident by inspection of the three types of characteristic.

**Effect of Throttling the Discharge.**—It is always necessary to make sure that the maximum static head is less than the head developed by the pump at no discharge. This is self-evident for the drooping characteristic, but the rising characteristic is misleading in this respect as the head rises above that at shut-off. Since for a certain range of head two different outputs are possible, it might seem that the operation of the pump under such conditions would be unstable. This instability, however, is counteracted by the frictional resistance in the suction and delivery pipes, which usually amounts to a considerable part of the total head. Any centrifugal pump with rising characteristic will therefore work satisfactorily if the maximum static head is less than the head produced at shut-off. If the frictional resistance is small it may be increased by throttling the discharge, so that by adjusting the throttle it is possible to operate the pump at any point of the curve with absolute stability.

**Numerical Illustration.**—The particular curves shown in Fig. 198 were plotted for an 8-in., 3-stage turbine fire pump built by the Alberger Co., New York, and designed to deliver 750 gal. per minute against an effective head of 290 ft., the pump being direct connected to a 75 H.P. 60-cycle induction motor operating at a synchronous speed of 1200 r.p.m.

The head curve shows that this pump would deliver two fire streams of 250 gal. per minute each at a pressure of 143 lb. per square inch; three streams of 250 gal. per minute each at a pressure of 125 lb. per square inch; four streams of 250 gal. per minute each at a pressure of nearly 100 lb. per square inch; or even five fairly good streams at a pressure of 80 lb. per square inch. With the discharge valve closed the pump delivers no water but produces a pressure equivalent to a head of 308 ft.

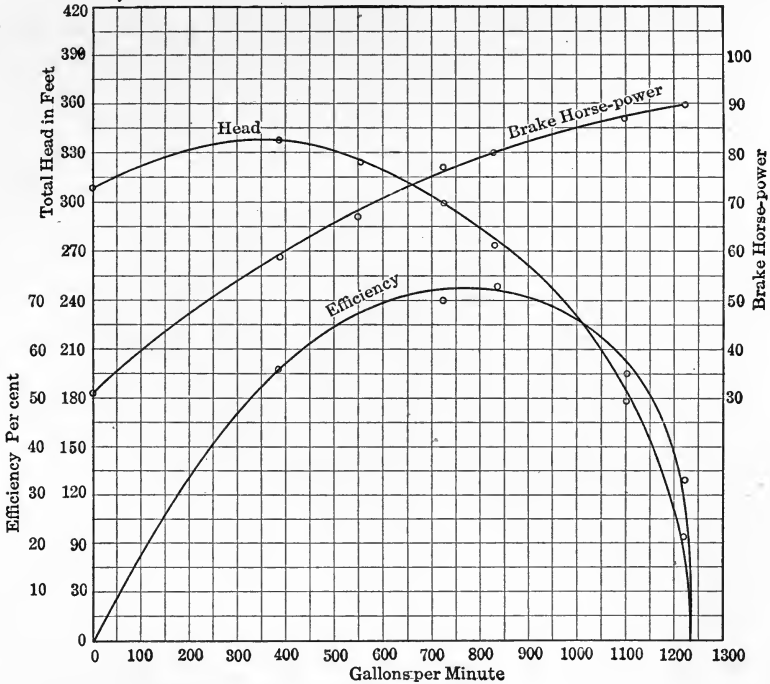

FIG. 198.

If the head against which the pump operates exceeds this amount, it is of course impossible to start the discharge. The head for which this particular pump was designed was 290 ft., which corresponds to the point of maximum efficiency. It is therefore apparent that the operating head must be carefully ascertained in advance, for if it is higher than that for which the pump was designed, both the efficiency and the capacity are diminished, whereas if it is lower, the capacity is increased but the efficiency is diminished.

The power curve shows that under low heads the power rises. Also that the overload in the present case is confined to about 12 per cent. of the normal power. Consequently the motor could only be overloaded 12 per cent. if all the hose lines should burst, whereas the head curve shows that if all the nozzles were shut off no injurious pressure would result.

The efficiency curve always starts at zero with zero capacity, as the pump does no useful work until it begins to discharge. The desirable features of an efficiency curve are steepness at the two ends, a flat top and a large area. Steepness at the beginning shows that the efficiency rises rapidly as the capacity increases, whereas a flat top and a steep ending show that it is maintained at a high value over a wide range. Since the average efficiency is obtained by dividing the area enclosed by the length of the base, it is apparent that the greater the area for a given length, the greater will be the average efficiency.

#### 45. EFFICIENCY AND DESIGN OF CENTRIFUGAL PUMPS

**Essential Features of Design.**—The design of centrifugal pumps like that of hydraulic turbines requires practical experience as well as detailed mathematical analysis. The general principles of design, however, are simple and readily understood, as will be apparent from what follows:

Three quantities are predetermined at the outset. The inner radius of the impeller,  $r_1$ , is ordinarily the same as the radius of the suction pipe; the outer radius,  $r_2$ , is usually made twice  $r_1$ ; and the angular speed  $\omega$  at which the impeller is designed to run is fixed by the particular type of prime mover by which the pump is to be operated.

The chief requirement of the design is to avoid impact losses. In order therefore that the water shall glide on the blades of the impeller without shock, the relative velocity of water at entrance must be tangential to the tips of the vanes.

Assuming the direction of flow at entrance to be radial, which is the assumption usually made although only approximately realized in practice, the necessary condition for entrance without shock is (Fig. 192)

$$v_1 = u_1 \tan \theta_1,$$



which determines the angle  $\theta_1$ . The relative velocity of water and vane at entrance is then

$$w_1 = \sqrt{u_1^2 + v_1^2}.$$

The direction of the outer tips of the vanes, or angle  $\theta_2$ , Fig. 192, is determined in practice by the purpose for which the pump is designed, as indicated in Art. 44. For an assigned value of  $\theta_2$ , the absolute velocity of the water at exit is

$$v_2^2 = u_2^2 + w_2^2 - 2u_2w_2 \cos \theta_2$$

and consequently as  $\theta_2$  increases, the absolute velocity at exit,  $v_2$ , also increases.

Let  $s_1, s_2$ , Fig. 192, denote the radial velocity of flow at entrance and exit, respectively, and  $A_1, A_2$  the circumferential areas of the impeller at these points. Then for continuous flow  $s_1A_1 = s_2A_2$ . Usually  $s_1 = s_2$ , in which case  $A_1 = A_2$ . If  $b_1$  and  $b_2$  denote the breadth of the impeller at inlet and outlet respectively, then  $A_1 = 2\pi r_1 b_1$  and  $A_2 = 2\pi r_2 b_2$ , and consequently for  $A_1 = A_2$  we have  $b_1 r_1 = b_2 r_2$ . Assuming the radial velocity of flow throughout the impeller to be constant, the breadth  $b$  at any radius  $r$  is given by the relation  $br = b_1 r_1$ .

**Hydraulic and Commercial Efficiency.**—Let  $H'$  denote the total effective head against which the pump operates, including suction, friction, delivery and velocity heads. Then if  $w$  denotes the velocity of the water as it leaves the delivery pipe,  $h$  the total lift including suction and delivery heads, and  $h_f$  the friction head, we have

$$H' = h + h_f + \frac{w^2}{2g}.$$

The total theoretical head  $H$  developed by the pump, as derived in Art. 43, is

$$H = \frac{v_1^2 + kv_2^2 + u_2^2 - w_2^2}{2g}.$$

Consequently the *hydraulic efficiency* of the pump is the ratio of these two quantities, that is,

$$\text{Hydraulic efficiency} = \frac{H'}{H}.$$

The *commercial efficiency* of the pump is the ratio of the work actually done in lifting the water through the height  $h$  to the

total work expended in driving the impeller shaft, and is of course less than the hydraulic efficiency.

#### 46. CENTRIFUGAL PUMP APPLICATIONS

**Floating Dry Docks.**—To illustrate the wide range of applications to which centrifugal pumps are adapted, a few typical examples of their use will be given.

The rapid extension of the world's commerce in recent years has created a demand for docking facilities in comparatively isolated ports, which has given rise to the modern floating dry dock (Fig. 199). In docks of this type the various compartments into

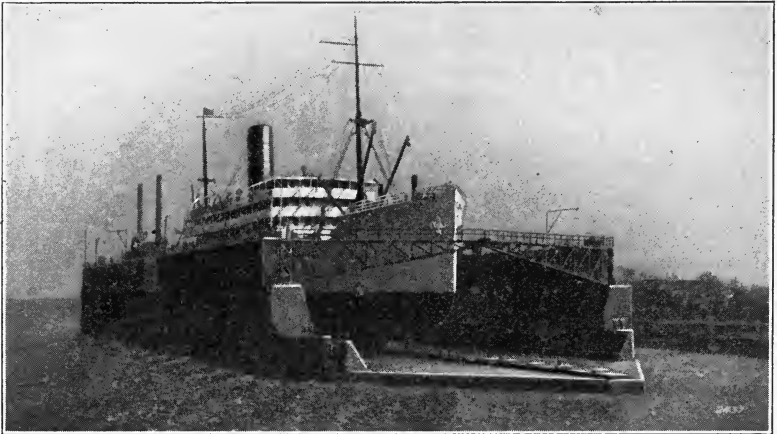

FIG. 199.

which they are divided are provided with separate pumps so that they may be emptied in accordance with the distribution of weight on the dock. Provision is usually made for handling one short vessel, two short vessels, or one extremely long ship, the balancing of the dock on an even keel being accomplished by emptying the various compartments in proportion to the weight sustained. The number of pumps in docks of this type varies from 6 to 20, depending on the number of compartments. The centrifugal pump is widely used and particularly suitable for this class of work, where a large quantity of water has to be discharged in a short time against a changing head which varies from zero

when the pumping begins to 30 or 40 feet when the dock is nearly dry (Fig. 200).<sup>1</sup>

**Deep Wells.**—In obtaining a water supply from deep wells, the problem is to secure a pump which will handle a large quantity of water efficiently in a drilled well of moderate diameter, the standard diameters of such wells being 12 and 15 in. To meet this demand, centrifugal pumps are now built which will deliver from 300 to 800 gal. per minute from a 12-in. well, and from 800 to 1500 gal. per minute from a 15-in. well, with efficiencies ranging from 55 to 75 per cent. The depth from which the water is pumped may be 300 ft. or more, the pumps being built in several stages according to the depth (Fig. 201).

**Mine Drainage.**—The extensive use of electric power for operating mining machinery has led to the employment of centrifugal pumps for mine drainage. The advantages of this type of pump when direct connected to a high

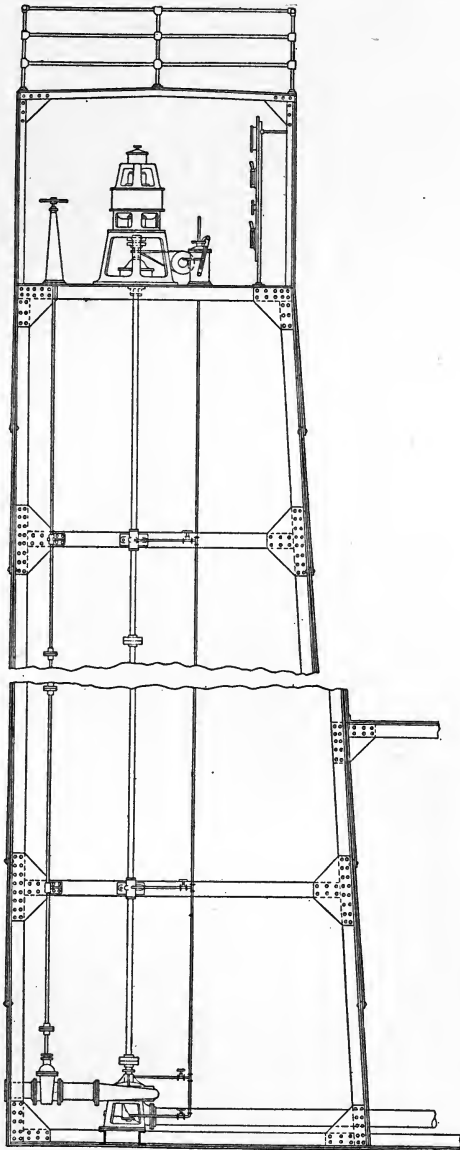

FIG. 200.

<sup>1</sup>Figs. 199-203 are reproduced by permission of the Platt Iron Works Co., Dayton, Ohio.

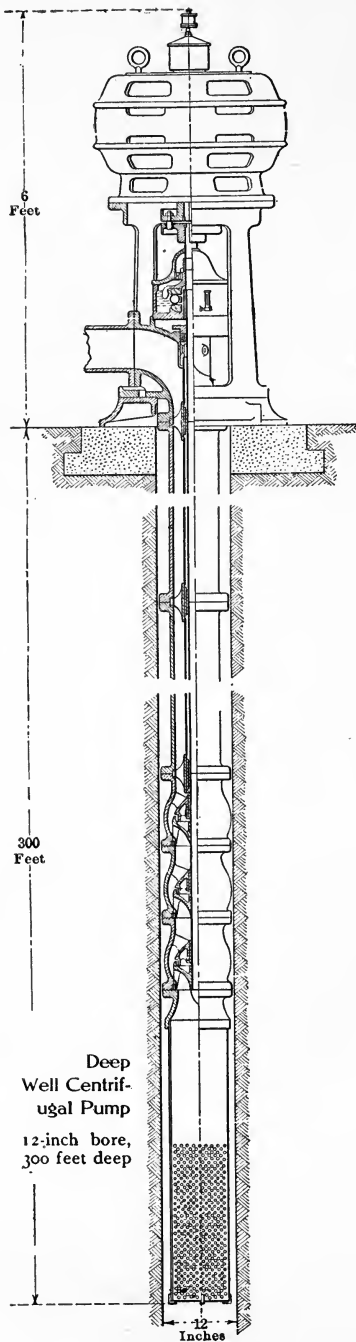

FIG. 201.

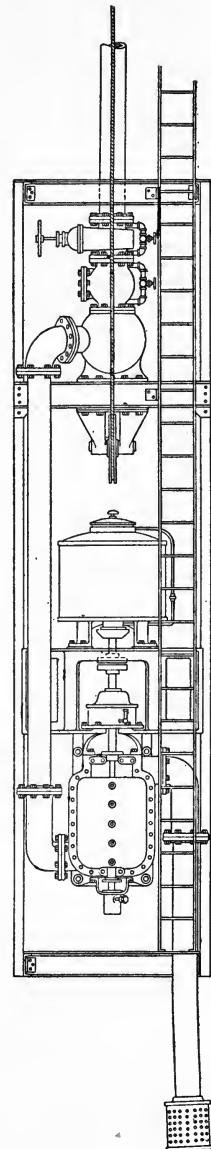

FIG. 202.

speed motor are its compactness, simplicity and low first cost. Fig. 202 illustrates a mine sinking turbine pump which operates against a 1250 ft. head in a single lift. Pumps of similar design are in operation in nearly all the important mining regions of the United States and Mexico. The turbine pump is used to best advantage where it is required to unwater a flooded mine shaft. For actual sinking work a displacement pump is preferable unless an ample sump is provided in order to keep the turbine pump well supplied with water so that it will not take air.

**Fire Pumps.**—The use of centrifugal pumps for fire protection has been formally approved by the Fire Insurance Underwriters,

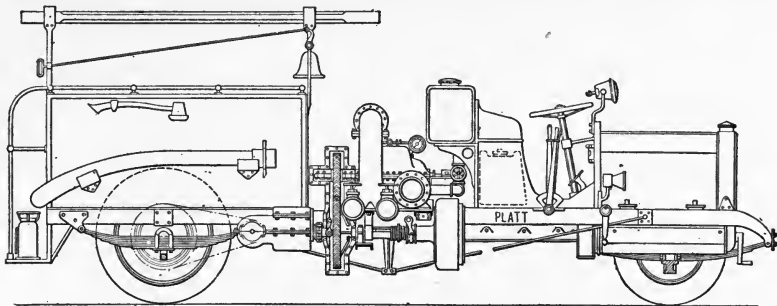

FIG. 203.

who have issued specifications covering the essential features of a pump of this type to comply with their requirements. In the case of fire boats the centrifugal pump has been found to fully meet all demands. The New York fire boats "James Duane" and "Thomas Willett" are equipped with turbine pumps, each of which has a capacity of 4500 gal. per minute against 150 lb. per square inch pressure. For automobile fire engines, the great range of speed for gas engines gives the centrifugal pump a great advantage, making it possible to throw streams to a great height by merely increasing the speed of the motor. This type can also be readily mounted on a light chassis and driven from the driving shaft of the machine, making a light, compact, flexible and efficient unit (Fig. 203).

**Hydraulic Dredging.**—The rapid development and improvement of internal waterways in the United States has demonstrated the efficiency of the hydraulic or suction dredge. The advantage of the hydraulic dredge over the dipper and ladder types is that it not only dredges the material but also delivers it at the desired

point with one operation. Its cost for a given capacity is also less than for any other type of dredge, while its capacity is enormous, some of the Government dredges on the Mississippi handling over 3000 cu. yd. of material per hour.

In operation the dredging pump creates a partial vacuum in the suction pipe, sufficient to draw in the material and keep it moving, and also produces the pressure necessary to force the discharge to the required height and distance. Hundreds of such pumps, ranging from 6 to 20 in. in diameter, are used on western rivers for dredging sand and gravel for building and other purposes. The dredge for this class of service is very simple, consisting principally of the dredging pump with its driving equipment mounted on a scow, the suction pipe being of sufficient length to reach to the bottom, and the material being delivered into a flat deck scow with raised sides, so that the sand is retained and the water flows overboard.

For general dredging service where hard material is handled, it is necessary to use an agitator or cutter to loosen the material so that it can be drawn into the suction pipe. In this case the suction pipe is mounted within a structural steel ladder of heavy proportions to stand the strain of dredging in hard material, and of sufficient length to reach to the depth required. The cutter is provided with a series of cutting blades, and is mounted on a heavy shaft supported on the ladder, and driven through gearing by a separate engine (Fig. 204).

Usually two spuds are arranged in the stern of the dredge to act as anchors and hold the dredge in position. The dredge is then swung from side to side on the spuds as pivots by means of lines on each side controlled by a hoisting engine, thus controlling the operation of the dredge.

Suction dredges are usually equipped with either 12-, 15-, 18- or 20-in. dredging pumps, the last named being the standard size. For most economical operation as regards power, the velocity through the pipe line should not be greater than just sufficient to carry the material satisfactorily.

With easily handled material the delivery pipe may be a mile or more in length, but with heavy material requiring high velocity the length should not exceed 4000 ft. The practical maximum discharge pressure is about 50 lb. per square inch. For long pipe lines it therefore becomes necessary to use relay pumps, the dredging pump delivering through a certain length of pipe

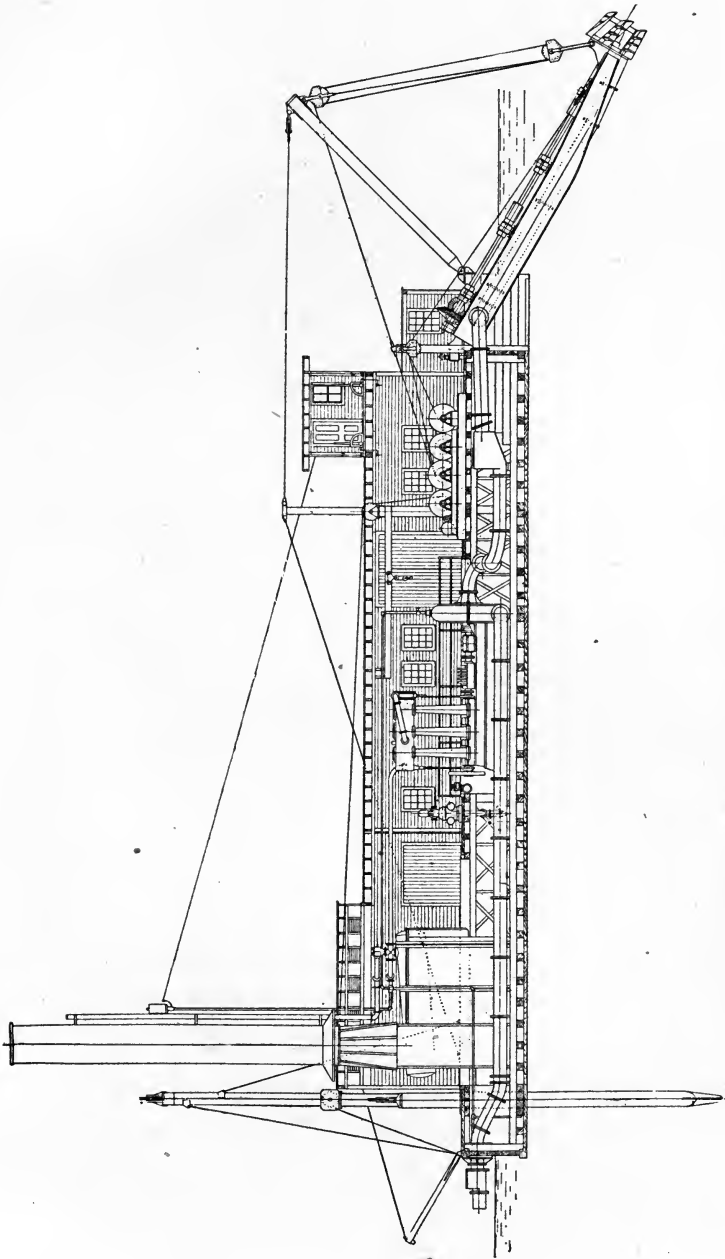

FIG. 204.—Suction dredge built by the Morris Machine Works, Baldwinsville, N. Y.

into the suction of the relay pump, and the latter delivering it through the remainder of the line. For high elevations or very long lines, several relay pumps may have to be used.

The efficiency of a dredging pump is usually only 40 or 50 per cent., a high efficiency in this case not being so important as the ability to keep going.

**Hydraulic Mining.**—The centrifugal pump is also successfully used in hydraulic mining, where a high pressure jet is used to wash down a hill. A number of centrifugal pumps are used for this purpose in the phosphate mines of Florida. Other uses for centrifugal pumps besides those described above are found in municipal water works, sewage and drainage plants, sugar refineries, paper mills and irrigation works.

### APPLICATIONS

**101.** A jet 2 in. in diameter discharges 5 cu. ft. of water per second which impinges on a flat vane moving in the same direction as the jet with a velocity of 12 ft. per second. Find the horse power expended on the vane.

**102.** A fireman holds a hose from which a jet of water 1 in. in diameter issues at a velocity of 80 ft. per second. What force will the fireman have to exert to support the jet?

**103.** A small vessel is propelled by two jets each 9 in. in diameter. The water is taken from the sea through a vertical inlet pipe with scoop facing forward, and driven astern by a centrifugal pump 2 ft. 6 in. in diameter running at 428 r.p.m. and delivering approximately 2250 cu. ft. of water per second. If the speed of the boat is 12.6 knots (1 knot = 6080 ft. per hour), calculate the hydraulic efficiency of the jet.

**104.** In the preceding problem, the efficiency of the pump was 48 per cent. and efficiency of engine and shafting may be assumed as 80 per cent. Using these values, calculate the total hydraulic efficiency of this system of propulsion.

**NOTE.**—The jet propeller is more efficient than the screw propeller, the obstacle preventing the adoption of this system in the past being the low efficiency obtainable from centrifugal pumps.

**105.** A locomotive moving at 60 miles per hour scoops up water from a trough between the rails by means of an L-shaped pipe with the horizontal arm projecting forward. If the trough is 2000 ft. long, the pipe 10 in. in diameter, the opening into the



tank 8 ft. above the mouth of the scoop, and half the available head is lost at entrance, find how many gallons of water are lifted into the tank in going a distance of 1600 ft. Also find the slowest speed at which water will be delivered into the tank.

**106.** A tangential wheel is driven by two jets each 2 in. in diameter and having a velocity of 75 ft. per second. Assuming the wheel efficiency to be 85 per cent. and generator efficiency 90 per cent., find the power of the motor in kilowatts (1 H.P. = 746 watts = 0.746 kilowatt).

**107.** In a commercial test of a Pelton wheel the diameter of the jet was found to be 1.89 in., static head on runner 386.5 ft., head lost in pipe friction 1.8 ft., and discharge 2.819 cu. ft. per second. The power developed was found by measurement to be 107.4 H.P. Calculate the efficiency of the wheel.

**108.** A nozzle having an efflux coefficient of 0.8 delivers a jet 1-1/2 in. in diameter. Find the amount and velocity of the discharge if the jet exerts a pressure of 200 lb. on a flat surface normal to the flow.

**109.** A jet 2 in. in diameter is deflected through  $120^\circ$  by striking a stationary vane. Find the pressure exerted on the vane when the nozzle is discharging 10 cu. ft. per second.

**110.** A power canal is 50 ft. wide and 9 ft. deep, with a velocity of flow of 1-1/2 ft. per second. It supplies water to the turbines under a head of 30 ft. If the efficiency of the turbines is 80 per cent., find the horse power available.

**111.** It is proposed to supply 1200 electrical horse power to a city 25 miles from a hydraulic plant. The various losses are estimated as follows:

Generating machinery, 10 per cent.; line, 8 per cent.; transformers at load end, 9 per cent.; turbine efficiency, 80 per cent.

The average velocity of the stream is 3 ft. per second, available width 90 ft., and depth 6 ft. Find the net fall required at the dam.

**112.** The head race of a vertical water wheel is 6 ft. wide and the water 9 in. deep, flowing with a velocity of 5 ft. per second. If the total fall is 20 ft. and the efficiency of the wheel is 70 per cent., calculate the horse power available from it.

**113.** A stream is 150 ft. wide with an average depth of 4 ft. and a velocity of flow of 1 ft. per second. If the net fall at the dam is 20 ft. and the efficiency of the wheel is 75 per cent., find the horse power available.

**114.** Eighty gallons of water per minute are to be pumped from a well 12 ft. deep by a pump situated 50 ft. from the well, and delivered to a tank 400 ft. from the pump and at 80 ft. elevation. The suction pipe is 3 in. in diameter and has two 3-in. elbows. The discharge pipe is 2-1/2 in. in diameter and has three 2-1/2-in. elbows. Find the size of engine required.

**NOTE.**—The lift is 92 ft. and the friction head in pipe and elbows amounts to about 25 ft., giving a total pumping head of 117 ft. The pump friction varies greatly, but for a maximum may be assumed as 50 per cent. of the total head, or, in the present case, 58-1/2 ft.

**115.** A single acting displacement pump raises water 60 ft. through a pipe line 1 mile long. The inside diameter of the pump barrel is 18 in., the stroke is 4 ft., and the piston rod is driven by a connecting rod coupled to a crank which makes 30 r.p.m. The velocity of flow in the pipe line is 3 ft. per second. Assuming the mechanical efficiency of the pump to be 75 per cent., and the slip 5 per cent., find the horse power required to drive the pump and the quantity of water delivered.

**116.** A 6-in. centrifugal pump delivers 1050 gal. per minute, elevating 20 ft. The suction and discharge pipes are each 6 in. in diameter and have a combined length of 100 ft. Find the friction head, total horse power required, and speed of pump for 50 per cent. efficiency.

**NOTE.**—The velocity of flow in this case is 12 ft. per second and the corresponding friction head for 100 ft. of 6-in. pipe is 8.8 ft. The total effective head is therefore 28.8 ft., requiring 15.26 H.P. at a speed of 410 r.p.m.

**117.** In the preceding problem show that if an 8-in. pipe is used instead of 6-in. there will be a saving in power of over 22 per cent.

**118.** A hydraulic ram uses 1000 gal. of water per minute under a 4-ft. head to pump 40 gal. per minute through 300 ft. of 2-in. pipe into a reservoir at an elevation of 50 ft. above the ram. Calculate the mechanical and hydraulic efficiencies of the ram, assuming the coefficient of pipe friction as 0.024.

**119.** An automobile booster fire pump, used for making a quick initial attack on a fire, is required to deliver two streams through 3/8-in. nozzles and 250 ft. of 1-in. hose. The pump is of the centrifugal type and is geared up to a speed of 3500 r.p.m. from the gas engine which drives the machine. Calculate the

discharge in gallons per minute and the horse power required to drive the pump, assuming 50 per cent. efficiency.

NOTE.—For this size nozzle, the maximum discharge is reached with a nozzle pressure of about 68 lb. per square inch corresponding to a velocity of about 100 ft. per second.

120. Feed water is pumped into a boiler from a round vertical tank 2-1/2 ft. in diameter. Before starting the pump the water level in the boiler is 38 in., and in the tank 22 in., above the floor level, and when the pump is stopped these levels are 40 in. and 15 in. respectively. If the steam pressure in the boiler while the pump is at work is 100 lb. per square inch find the number of foot-pounds of work done by the pump.

121. A fire pump delivers three fire streams, each discharging 250 gal. per minute under 80 lb. per square inch pressure. Find the horse power of the engine driving the pump if the efficiency of the engine is 70 per cent. and of the pump is 60 per cent.

122. A mine shaft 580 ft. deep and 8 ft. in diameter is full of water. How long will it take a 6-H.P. engine to unwater the shaft if the efficiencies of pump and engine are each 75 per cent.?

123. A fire engine pumps at the rate of 500 gal. per minute against a pressure of 100 lb. per square inch. Assuming the overall efficiency to be 50 per cent., calculate the indicated horse power of the engine.

124. A water power plant is equipped with tangential wheels having an efficiency of 80 per cent. The water is delivered to the wheels through a cylindrical riveted steel penstock 5 miles long with a total fall of 900 ft., practically the entire penstock being under this head.

The cost of power house and equipment is estimated at \$50,000, penstock 6 cents per pound, operating expenses \$5000 per annum, and interest on total investment 4 per cent. per annum. The income is to be derived from the sale of power at \$12 per horse power per annum. A constant supply of water of 100 cu. ft. per minute is available.

(A) Plot a curve with diameter of penstock as abscissa and yearly gross income as ordinate.

(B) Plot a curve with diameter of penstock as abscissa and yearly gross expenses as ordinate.

(C) From these two curves determine the two values of the diameter of penstock for either of which the net income is zero,

and the one value for which the net income is a maximum, and find the amount of the latter.

**125.** A hydraulic pipe line is required to transmit 150 H.P. with a velocity of flow not greater than 3 ft. per second and a delivery pressure of 900 lb. per square inch. Assuming that the most economical size of pipe is one which allows a pressure drop of about 10 lb. per square inch per mile, determine the required size of pipe.

**126.** Find the maximum horse power which can be transmitted through a 6-in. pipe 4 miles long assuming the inlet pressure to be 800 lb. per square inch and the coefficient of pipe friction to be 0.024. Also determine the velocity of flow and outlet pressure.

**127.** A 6-in. pipe half a mile long leads from a reservoir to a nozzle located 350 ft. below the level of the reservoir and discharging into the air. Assuming the coefficient of friction to be 0.03, determine the diameter of nozzle for maximum power.

**128.** A 10-in. water main 900 ft. long is discharging 1000 gal. of water per minute. If water is shut off in 2 sec. by closing a valve, how much is the pressure in the pipe increased?

**129.** In a series of experiments made by Joukowsky on cast-iron pipes, the time of valve closure in each case being 0.03 sec., the following rises in pressures were observed.<sup>1</sup> Show that these results give the straight line formula,  $p = 57v$ .

CAST-IRON PIPE, DIAM. 4 IN., LENGTH 1050 FT.

Vel. in ft./sec.....	0.5	2.0	3.0	4.0	9.0
Observed pressure in lb./in. <sup>2</sup> ...	31	119	172	228	511
Cast-iron pipe, diameter 6 in., length 1066 ft.					
Vel. in ft./sec.....	0.6	2.0	3.0	7.5	
Observed rise in pressure in lb./in. <sup>2</sup> ....	43	113	173	426	

**130.** It is customary in practice to make allowance for possible water hammer by designing the pipes to withstand a pressure of 100 lb. per square inch in excess of that due to the static head. Show that this virtually allows for an instantaneous stoppage at a velocity of 1.6 ft. per second.

**131.** A bowl in the form of a hemisphere, with horizontal rim,

<sup>1</sup>Gibson: Hydraulics and Its Applications, p. 239.

is filled with liquid and then given an angular velocity  $\omega$  about its vertical axis. How much liquid flows over the rim (Fig. 205)?

132. A closed cylindrical vessel of height  $H$  is three-fourths full of water. With what angular velocity  $\omega$  must it revolve around its vertical axis in order that the surface paraboloid shall just touch the bottom of the vessel (Fig. 206).

133. A closed cylindrical vessel of diameter 3 ft. and height 6 in. contains water to a depth of 2 in. Find the speed in r.p.m. at which it must revolve about its vertical axis in order that the water shall assume the form of a hollow truncated paraboloid for which the radius of the upper base is 1 per cent. greater than the radius of the lower base; or, referring to Fig. 207, such that  $r_1 = 1.01r_2$ .

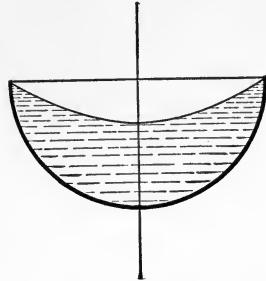

FIG. 205.

134. The test data for a 19-in. New American turbine runner are as follows:

Head 25 ft.; speed 339 r.p.m.; discharge 2128 cu. ft. per min.; power developed 80 H.P.

Calculate the turbine constants including the characteristic speed.

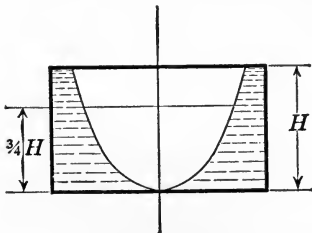

FIG. 206.

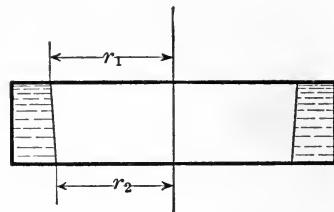

FIG. 207.

*Solution.*—In this case, from Article 36,

$$k_v = \frac{\pi dn}{60 \sqrt{h}} = \frac{\pi \frac{19}{12} 339}{60 \sqrt{25}} = 5.62;$$

$$\varphi = \frac{k_v}{\sqrt{2g}} = \frac{5.62}{\sqrt{64.4}} = 0.7;$$

$$Q_1 = \frac{Q}{\sqrt{h}} = \frac{2128}{\sqrt{25}} = 7.0933;$$

$$k_a = \frac{Q_1}{d^2} = \frac{7.0933}{\left(\frac{19}{12}\right)^2} = 2.829;$$

$$N_s = \frac{n \sqrt{H.P.}}{h^4 \sqrt{h}} = \frac{339 \sqrt{80}}{25^4 \sqrt{25}} = 54.24.$$

**135.** Two types of turbine runner, *A* and *B*, are to be compared. From tests it is known that runner *A* will develop a maximum of 2080 H.P. at 500 r.p.m. under 100 ft. head, and runner *B* will develop 4590 H.P. at 580 r.p.m. under 150 ft. head. Determine which of these types is the higher speed.

*Solution.*—Type *A*,  $N_s = \frac{500 \sqrt{2080}}{100^4 \sqrt{100}} = 72.11,$

Type *B*,  $N_s = \frac{580 \sqrt{4590}}{150^4 \sqrt{150}} = 74.86.$

**136.** Show that to transform the characteristic speed  $N_s$  from the English to the metric system it is necessary to multiply by the coefficient 4.46; that is to say, if the horse power and head are expressed in foot-pound units, and  $N_s$  in the metric system, we have the relation

$$N_s = 4.46n \frac{\sqrt{H.P.}}{h^{5/4}}.$$

**137.** Five two-runner Francis turbines installed in the power house of the Pennsylvania Water and Power Co. at McCall's Ferry on the Susquehanna River are rated at 13,500 H.P. each under a head of 53 ft. at a speed of 94 r.p.m. The quantity of water required per turbine is 2800 cu. ft. per second. Calculate from this rating the characteristic speed, efficiency, and other turbine constants.

**138.** Four two-runner Francis turbines operating in the Little Falls plant of the Washington Water Power Co. have a nominal power capacity of 9000 H.P. each under a head of 66 ft. at a speed of 150 r.p.m. The quantity of water required per turbine is 1500 cu. ft. per second. From this rating calculate the characteristic speed, efficiency, and specific constants for these units.

**139.** The upper curve shown in Fig. 208 is the official efficiency test curve of the 9000 H.P. turbines, built by the I. P.

Morris Co. for the Washington Water Power Co. These wheels are of the horizontal shaft, two-runner, central discharge type, with volute casings. Head 66 ft., speed 150 r.p.m., and rated runner diameter 6 ft. 2 in.

The lower curve shown in the figure is derived from a test at Holyoke of a homologous experimental runner having a rated diameter of 2 ft. 8-13/14 in. These curves are almost identical in shape, the efficiency of the large units exceeding by a small margin that of the experimental runner.

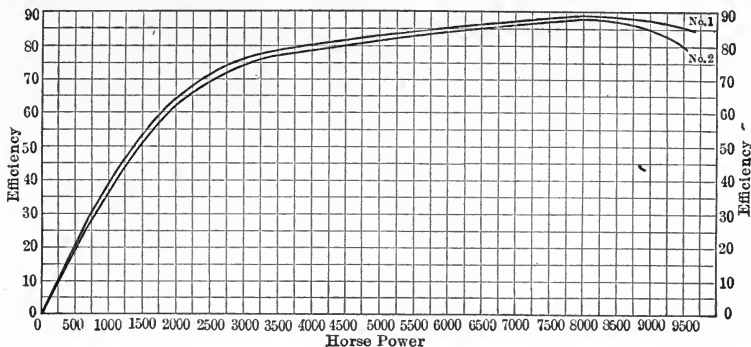

FIG. 208.

Calculate the discharge and characteristic speed at maximum efficiency, and from these results compute the specific constants.

**140.** In testing a hydraulic turbine it was found by measurement that the amount of water entering the turbine was 8000 cu. ft. per minute with a net fall of 10.6 ft. The power developed was measured by a friction brake clamped to a pulley. The length of brake arm was 12 ft., reading on scales 400 lb., and speed of pulley 100 r.p.m. Calculate the efficiency of the turbine.

**141.** One of a series of 65 tests of a 31-in. Wellman-Seaver-Morgan turbine runner gave the following data:<sup>1</sup>

Gate opening 75 per cent.; head on runner 17.25 ft.; speed 186.25 r.p.m.; discharge 63.12 cu. ft. per second; power developed 111.66 H.P.

Calculate the efficiency and the various turbine constants.

**142.** One of a series of 82 tests of a 30-in. Wellman-Seaver-Morgan turbine runner gave the following data:<sup>2</sup>

<sup>1</sup> Characteristics of Modern Hyd. Turbines, C. W. Larner, Trans. Am. Soc. C. E., Vol. LXVI (1910), pp. 306-386.

<sup>2</sup> *Ibid.*

Gate opening 80.8 per cent.; head on runner 17.19 ft.; speed 206 r.p.m.; discharge 85.73 cu. ft. per second; power developed 146.05 H.P.

Calculate the efficiency and the other turbine constants.

**143.** Four of the turbines of the Toronto Power Co. at Niagara Falls are of the two-runner Francis type, with a nominal development of 13,000 H.P. each under a head of 133 ft. at a speed of 250 r.p.m. The quantity of water required per turbine is 1060 cu. ft. per second.

Calculate the efficiency, characteristic speed and specific turbine coefficients for these units.

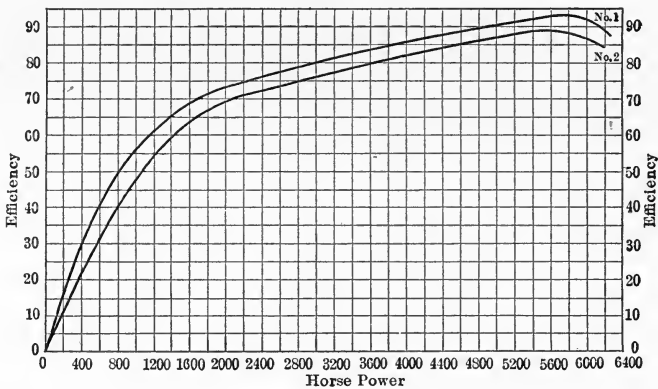

FIG. 209.

**144.** The upper curve shown in Fig. 209 is the official test curve of the 6000 H.P. turbines designed by the I. P. Morris Co. for the Appalachian Power Co. The rated runner diameter is 7 ft. 6-1/4 in., head 49 ft., and speed 116 r.p.m. These turbines are of the single runner, vertical shaft type.

The lower curve is derived from a test at Holyoke of the small, homologous, experimental runner, having a rated diameter of 27-3/8 in. The curves are identical in shape, but owing to the better arrangement of water passages in the large plant, its efficiency considerably exceeds that of the experimental runner. It may also be noted that the efficiency shown on this diagram is the highest ever recorded in a well-authenticated test.

Calculate the discharge and characteristic speed at maximum efficiency, and from these results compute the specific turbine constants.



145. The following data, taken from the official Holyoke test reports, give the results of tests made on a 35-in. vertical Samson turbine built by the James Leffel Co. of Springfield, Ohio. Calculate the turbine constants and characteristic speeds.

TESTS OF 35-IN. VERTICAL SAMSON TURBINE

Gate opening	Head on wheel in feet	Speed in rev. per min.	Discharge in. cu. ft. per sec.	Horse power developed	Efficiency in per cent.
Full gate.....	16.57	187	120.61	188.27	83.06
0.9 gate.....	16.69	191	114.35	188.88	87.26
0.8 gate.....	16.78	189	105.10	179.87	89.93
0.75 gate.....	16.86	187	100.29	172.57	89.99
0.7 gate.....	17.08	188	92.83	160.03	88.99
0.6 gate.....	17.23	185	77.15	128.22	85.05
0.5 gate.....	17.47	188	66.89	108.72	82.03

146. The speed and water consumption of a turbine vary as the square root of the head ( $\sqrt{h}$ ), and the power varies as the square root of the cube of the head ( $\sqrt{h^3}$ ). Thus if the head on a wheel is multiplied by 4, the speed and discharge will be multiplied by 2 and the power by 8.

Given that a 12-in. turbine under 12-ft. head develops 14 H.P. at 480 r.p.m. using 762 cu. ft. of water per minute, find the power, speed and discharge for the same turbine under 48-ft. head.

147. On page 252 is given a rating table of turbines manufactured by the S. Morgan Smith Co. of York, Pa., computed from actual tests of each size turbine under the dynamometer at the Holyoke testing flume.

Calculate the nominal efficiency and characteristic speed for each size runner, and determine whether it is of the low, medium or high speed type.

NOTE.—Data of this kind may be used by the instructor as problem material for an entire class without duplicating results, the final results being collected and tabulated, thus serving as a check on the calculations and also showing the range of the constants involved.

148. On pages 253, 254 and 255 is given a rating table of Victor Turbines manufactured by the Platt Iron Works Co., Dayton, Ohio.

Calculate the nominal efficiency, characteristic speed, and speed and capacity constants for each diameter and head.

RATING TABLE OF SMITH TURBINES

Dia. of wheel in inches	Horse power, cu. ft. discharged, revolutions per minute.	Head in feet														
		48	49	50	51	52	53	54	55	56	57	58	59	60	61	62
12	Horse power.....	112.0	115.8	119.3	122.8	126.4	130.2	134.0	137.7	141.6	145.3	149.3	153.0	156.8	160.8	164.8
	Cubic feet.....	1525	1544	1559	1574	1589	1605	1621	1636	1652	1666	1682	1695	1707	1722	1737
	Revolutions.....	960	970	980	990	1000	1009	1018	1028	1038	1047	1055	1064	1074	1083	1092
15	Horse power.....	176.8	182.9	188.6	194.3	200.0	205.7	211.8	217.6	223.2	229.5	235.6	241.8	248.0	254.0	260.3
	Cubic feet.....	2408	2439	2465	2490	2514	2536	2562	2585	2604	2632	2655	2679	2700	2720	2743
	Revolutions.....	768	776	784	793	800	807	814	822	830	837	844	851	858	866	873
18	Horse power.....	252.8	261.0	268.7	276.4	284.8	293.3	301.5	310.0	318.4	327.1	335.7	344.4	352.8	362.2	371.1
	Cubic feet.....	3443	3481	3512	3543	3580	3616	3648	3683	3715	3752	3783	3816	3842	3879	3911
	Revolutions.....	640	646	653	660	666	672	679	685	691	697	704	710	716	722	728
21	Horse power.....	344.0	354.7	365.4	376.1	387.2	399.0	410.4	421.5	432.8	445.0	456.7	468.4	480.0	492.7	504.8
	Cubic feet.....	4685	4731	4776	4821	4867	4919	4965	5007	5050	5104	5147	5190	5227	5276	5320
	Revolutions.....	549	554	560	565	570	576	582	587	592	597	603	608	614	620	626
24	Horse power.....	449.6	464.0	478.2	492.7	507.2	521.9	536.8	551.7	566.4	582.1	597.6	613.0	628.8	644.5	660.4
	Cubic feet.....	6123	6189	6250	6316	6375	6435	6495	6554	6610	6676	6735	6792	6847	6902	6960
	Revolutions.....	480	485	490	495	500	505	509	513	518	523	527	531	536	540	545
27	Horse power.....	568.8	586.7	604.7	623.1	641.6	660.0	678.8	697.6	716.4	736.1	755.7	775.1	795.2	814.9	835.0
	Cubic feet.....	7757	7826	7903	7988	8064	8137	8213	8287	8360	8443	8516	8588	8659	8727	8800
	Revolutions.....	426	430	435	439	444	448	453	457	462	466	470	474	478	482	486
30	Horse power.....	702.4	724.7	746.9	769.2	792.0	815.3	838.6	861.7	885.6	909.3	933.3	957.4	891.6	1006.7	1031.6
	Cubic feet.....	9566	9667	9762	9861	9955	10052	10147	10236	10334	10429	10518	10607	10689	10781	10873
	Revolutions.....	384	388	392	396	399	403	407	411	415	419	423	427	430	433	437

RATING TABLE OF WICKET GATE VICTOR TURBINES

Wheel diam., inches	Horse power, cubic feet discharged, revolutions per minute	Head in feet														
		36	37	38	39	40	41	42	43	44	45	46	47	48	49	50
12	Horse power.....	73.7	76.8	80	83.1	86	90	93	96	99	103	106	109	113	117	121
	Cubic feet.....	1356	1375	1394	1411	1430	1447	1465	1482	1498	1515	1533	1549	1566	1581	1597
	Revolutions.....	774	785	796	806	816	826	836	846	856	865	875	885	894	903	913
15	Horse power.....	115	120	125	129	135	140	145	150	155	161	166	172	177	183	188
	Cubic feet.....	2120	2148	2178	2206	2233	2261	2288	2314	2341	2369	2394	2420	2445	2472	2497
	Revolutions.....	620	629	637	645	649	661	669	676	685	693	701	708	715	722	730
18	Horse power.....	166	172	180	187	194	202	209	216	224	232	240	247	255	263	271
	Cubic feet.....	3051	3093	3134	3178	3206	3236	3295	3334	3372	3410	3448	3485	3523	3560	3595
	Revolutions.....	518	526	533	540	546	554	561	567	574	579	587	594	599	606	612
21	Horse power.....	225	235	245	254	265	275	285	295	305	316	326	337	348	358	370
	Cubic feet.....	4153	4210	4266	4324	4367	4434	4488	4540	4593	4644	4695	4747	4796	4846	4895
	Revolutions.....	443	450	455	462	467	474	479	485	490	496	501	507	512	518	523
24	Horse power.....	295	307	320	332	345	358	372	385	398	412	426	440	454	468	483
	Cubic feet.....	5424	5500	5572	5648	5718	5791	5861	5930	6000	6067	6134	6200	6265	6330	6394
	Revolutions.....	388	392	399	403	408	412	417	422	426	432	436	441	446	451	455
27	Horse power.....	373	389	405	421	447	454	470	487	505	522	540	557	575	593	611
	Cubic feet.....	6865	6960	7052	7147	7237	7329	7418	7505	7592	7677	7763	7847	7930	8011	8093
	Revolutions.....	344	348	354	357	363	367	372	376	379	384	388	392	397	401	405

RATING TABLE OF WICKET GATE VICTOR TURBINES.—Continued

Wheel diam., inches	Horse-power, cubic feet discharged, revolutions per minute	Head in feet														
		36	37	38	39	40	41	42	43	44	45	46	47	48	49	50
30	Horse power.....	461	480	500	520	540	560	581	601	623	644	666	688	710	732	754
	Cubic feet.....	8475	8594	8705	8825	8930	9047	9156	9265	9372	9477	9582	9686	9789	9891	9991
	Revolutions.....	310	315	319	322	328	331	334	339	342	346	350	354	358	362	365
33	Horse power.....	558	581	605	629	654	678	703	728	754	780	806	832	859	886	913
	Cubic feet.....	10256	10399	10536	10677	10812	10947	11080	11211	11340	11469	11594	11720	11845	11968	12089
	Revolutions.....	282	286	291	295	298	300	304	308	311	314	318	322	325	329	332
36	Horse power.....	664	691	720	738	778	809	836	867	897	928	959	990	1022	1054	1087
	Cubic feet.....	12205	12375	12537	12708	12867	13029	13187	13343	13498	13650	13800	13950	14097	14243	14393
	Revolutions.....	258	262	264	266	271	274	277	280	284	287	290	293	297	299	302
39	Horse power.....	779	811	845	878	913	947	982	1017	1053	1089	1125	1162	1200	1237	1276
	Cubic feet.....	14325	14525	14710	14914	15100	15290	15474	15658	15839	16018	16195	16369	16543	16715	16884
	Revolutions.....	237	242	244	247	251	254	256	259	262	265	268	271	275	277	279
42	Horse power.....	903	931	980	1019	1059	1098	1139	1180	1221	1263	1305	1349	1392	1435	1480
	Cubic feet.....	16613	16845	17064	17297	17513	17733	17950	18161	18371	18576	18784	18986	19188	19386	19583
	Revolutions.....	221	224	226	231	233	235	238	242	244	247	249	253	255	258	260
45	Horse power.....	1037	1081	1125	1170	1212	1261	1307	1354	1397	1450	1498	1548	1598	1647	1698
	Cubic feet.....	19072	19338	19591	19856	20103	20356	20601	20844	21086	21320	21560	21793	22024	22252	22478
	Revolutions.....	207	209	212	214	218	220	222	224	226	230	232	234	236	238	242

RATING TABLE OF WICKET GATE VICTOR TURBINES.—Continued

Wheel diam., inches	Horse power, cubic feet discharged, revolutions per minute	Head in feet														
		36	37	38	39	40	41	42	43	44	45	46	47	48	49	50
48	Horse power.....	1180	1229	1280	1331	1383	1433	1486	1539	1592	1648	1703	1759	1815	1872	1930
	Cubic feet.....	21699	22005	22288	22592	22874	23158	23438	23736	23990	24256	24529	24794	25056	25327	25574
	Revolutions.....	190	194	197	199	201	203	205	208	210	212	214	218	220	222	224
51	Horse power.....	1332	1388	1445	1503	1561	1620	1680	1740	1801	1863	1925	1988	2052	2116	2182
	Cubic feet.....	24497	24839	25162	25504	25823	26148	26464	26778	27088	27393	27697	27995	28292	28584	28875
	Revolutions.....	178	181	183	186	188	190	192	194	197	199	201	203	205	208	210
54	Horse power.....	1494	1556	1620	1684	1750	1816	1883	1950	2019	2088	2158	2230	2300	2373	2446
	Cubic feet.....	27464	27847	28207	28592	28959	29315	29669	30021	30368	30714	31051	31387	31718	32047	32372
	Revolutions.....	169	171	174	176	178	179	181	183	186	188	190	192	194	196	198
57	Horse power.....	1664	1734	1805	1877	1950	2023	2098	2173	2250	2327	2405	2484	2563	2654	2725
	Cubic feet.....	30600	31030	31432	31858	32256	32663	33059	33451	33837	34216	34597	34971	35341	35708	36071
	Revolutions.....	160	163	165	166	169	172	175	177	179	181	183	186	187	189	191
60	Horse power.....	1844	1921	2000	2080	2161	2242	2325	2408	2493	2578	2665	2752	2840	2930	3020
	Cubic feet.....	33905	34379	34827	35300	35741	36190	36629	37062	37491	37914	38334	38748	39159	39564	39966
	Revolutions.....	152	154	155	158	160	163	164	166	168	169	171	174	176	177	179

149. Fig. 210 shows a vertical section of the 10,800-H.P. turbines designed by the I. P. Morris Co. for the Cedar Rapids Mfg. and Power Co. The rated diameter of these turbines is 11 ft. 10-1/2 in., head 30 ft., and speed 55.6 r.p.m.

These turbines are at present the largest in the world, and it may be noted that all the latest features have been incorporated in the design, namely, volute casings and draft tubes molded in

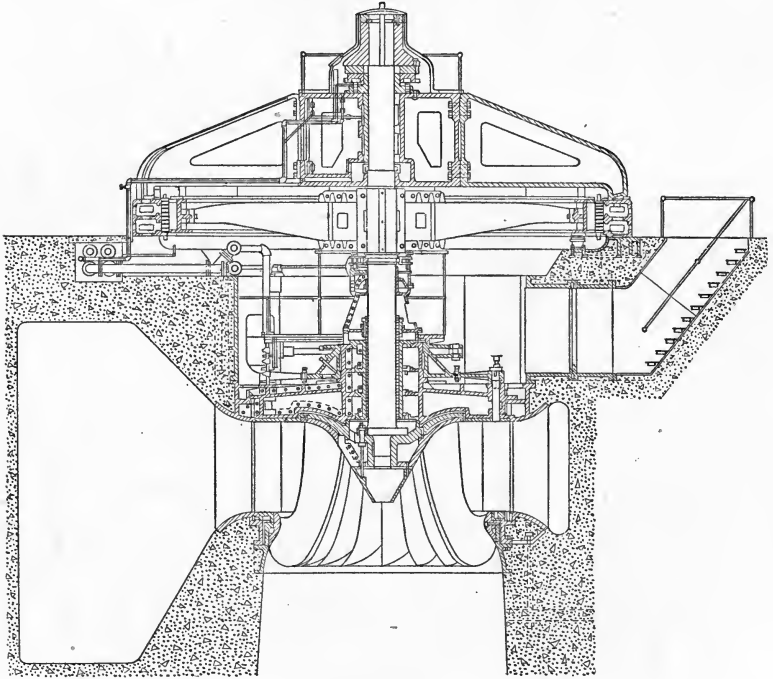

FIG. 210.

the concrete; cast-iron speed rings supporting the concrete, generator and thrust bearing loads from above; lignum vitæ turbine guide bearing; thrust bearing support located above the generator; Kingsbury thrust bearing with roller auxiliary; and pneumatic brakes acting on the rotor of the generator.

Calculate the characteristic speed from the rating given above, and from the table on page 188 determine to which speed type it belongs.

150. The following table gives the results of 20 tests out of a total of 66 made Sept. 3-4, 1912, at the testing flume of the

Holyoke Water Power Co. on a 24-in. Morris turbine type "O" runner. Calculate the characteristic speed for each test, and note its high value in test number 10.

NOTE.—Two of the wheels for the Keokuk installation and nine wheels for the Cedar Rapids plant are built with this type of runner, the large wheels being geometrically similar to the experimental wheel tested at Holyoke.

REPORT OF TESTS OF A 24-IN. MORRIS TURBINE, TYPE "O" RUNNER MADE IN THE TESTING FLUME OF THE HOLYOKE WATER POWER CO.

Number of experiment	Opening of speed gate in inches	Per cent. of full discharge of wheel	Head on wheel in feet	Speed in rev. per min.	Discharge in cu. ft. per sec.	Horse power developed	Efficiency in per cent.
1	3.0	0.792	17.39	344.25	84.66	103.98	62.31
2	3.0	0.779	17.40	298.00	83.35	126.01	76.66
3	3.0	0.775	17.39	275.75	82.91	133.26	81.55
4	3.0	0.778	17.36	257.50	83.13	139.99	85.59
5	3.0	0.779	17.33	249.20	83.13	143.01	87.58
6	3.0	0.782	17.30	241.25	83.35	145.73	89.17
7	3.0	0.779	17.30	235.50	83.13	146.53	89.89
8	3.0	0.781	17.28	238.25	83.24	146.80	90.05
9	3.0	0.783	17.27	240.20	83.46	146.55	89.71
10	3.0	0.781	17.23	236.80	83.13	146.62	90.32
11	3.0	0.762	17.31	214.00	81.28	138.97	87.15
12	3.0	0.782	17.24	237.20	83.24	146.51	90.08
13	3.0	0.744	17.34	185.50	79.44	128.86	82.54
14	3.5	0.902	17.15	357.20	95.73	107.89	57.98
15	3.5	0.900	17.10	320.50	95.38	135.52	73.31
16	3.5	0.903	17.06	287.75	95.61	156.44	84.62
17	3.5	0.892	17.14	265.75	94.70	160.53	87.26
18	3.5	0.871	17.17	243.25	92.55	154.29	85.67
19	3.5	0.903	17.15	280.20	95.84	160.80	86.32
20	3.5	0.904	17.19	278.60	96.07	164.09	87.67

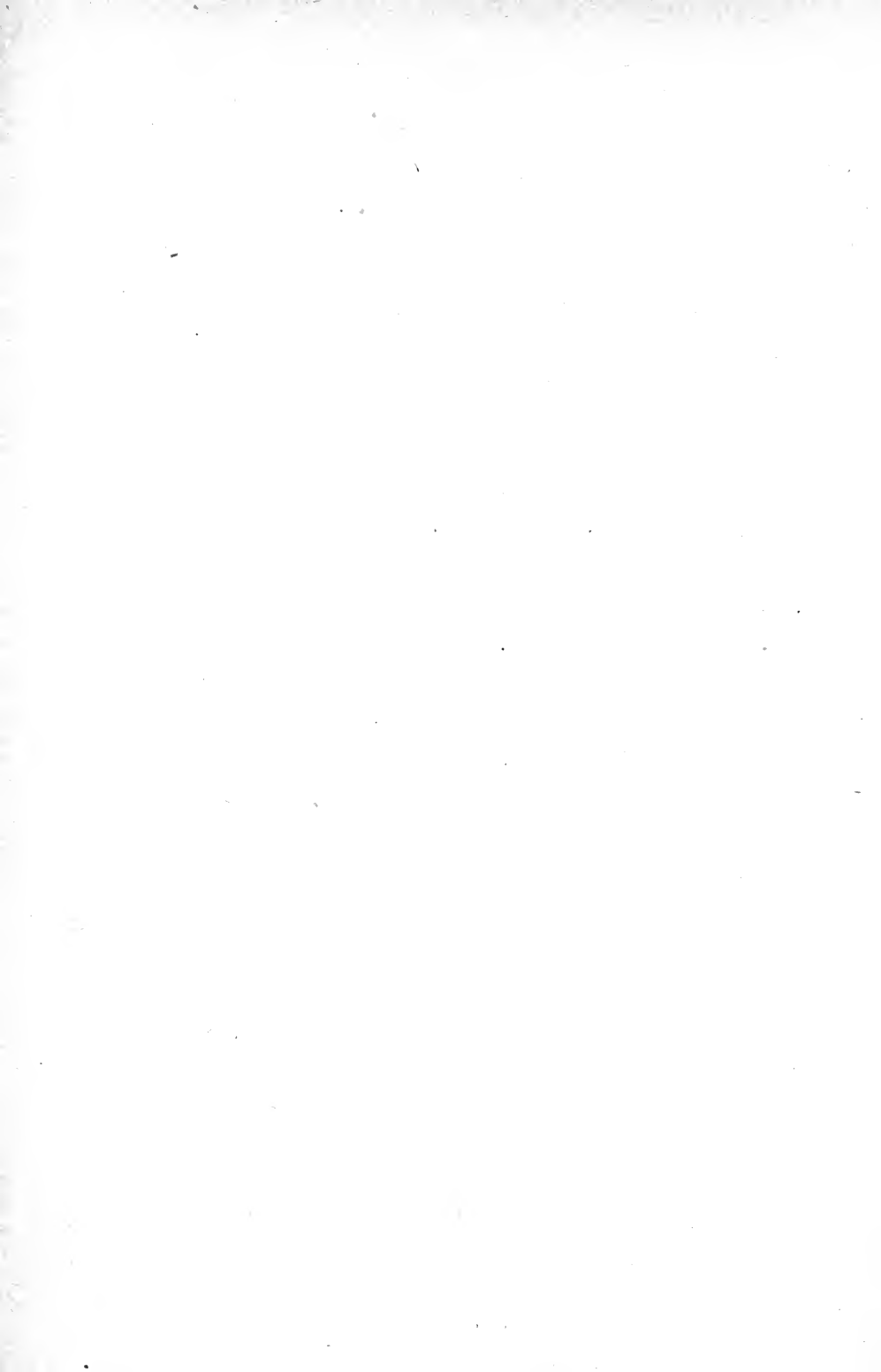



# HYDRAULIC DATA AND TABLES

TABLE 1.—PROPERTIES OF WATER

Density and Volume of Water

Temp. in degrees Centigrade	Density	Volume of 1 gram in cu. cm.	Temp. in degrees Centigrade	Density	Volume of 1 gram in cu. cm.
0	0.999874	1.00013	24	0.997349	1.00266
1	0.999930	1.00007	26	0.996837	1.00317
2	0.999970	1.00003	28	0.996288	1.00373
2	0.999993	1.00001	30	0.995705	1.00381
4	1.000000	1.00000	32	0.995087	1.00394
5	0.999992	1.00001	35	0.995098	1.00394
6	0.999970	1.00003	40	0.99233	1.00773
7	0.999932	1.00007	45	0.99035	1.00974
8	0.999881	1.00012	50	0.98813	1.01201
9	0.999815	1.00018	55	0.98579	1.01442
10	0.999736	1.00026	60	0.98331	1.01697
11	0.999643	1.00036	65	0.98067	1.01971
12	0.999537	1.00046	70	0.97790	1.02260
13	0.999418	1.00058	75	0.97495	1.02569
14	0.999287	1.00071	80	0.97191	1.02890
16	0.998988	1.00101	85	0.96876	1.03224
18	0.998642	1.00136	90	0.96550	1.03574
20	0.998252	1.00175	95	0.96212	1.03938
22	0.997821	1.00218	100	0.95863	1.04315

Weight of Water

Temp. in degrees Fahrenheit	Weight in pounds per cu. ft.	Temp. in degrees Fahrenheit	Weight in pounds per cu. ft.	Temp. in degrees Fahrenheit	Weight in pounds per cu. ft.
32	62.42	100	62.02	170	60.77
40	62.42	110	61.89	180	60.55
50	62.41	120	61.74	190	60.32
60	62.37	130	61.56	200	60.07
70	62.31	140	61.37	210	59.82
80	62.23	150	61.18	212	59.56
90	62.13	160	60.98		

TABLE 2.—HEAD AND PRESSURE EQUIVALENTS

Head of Water in Feet and Equivalent Pressure in Pounds per Sq. In.

Feet head	Pounds per sq. in.	Feet head	Pounds per sq. in.	Feet head	Pounds per sq. in.
1	0.43	55	23.82	190	82.29
2	0.87	60	25.99	200	86.62
3	1.30	65	28.15	225	97.45
4	1.73	70	30.32	250	108.27
5	2.17	75	32.48	275	119.10
6	2.60	80	34.65	300	129.93
7	3.03	85	36.81	325	140.75
8	3.40	90	38.98	350	151.58
9	3.90	95	41.14	375	162.41
10	4.33	100	43.31	400	173.24
15	6.50	110	47.64	500	216.55
20	8.66	120	51.97	600	259.85
25	10.83	130	56.30	700	303.16
30	12.99	140	60.63	800	346.47
35	15.16	150	64.96	900	389.78
40	17.32	160	69.29	1000	433.09
45	19.49	170	73.63	.....	.....
50	21.65	180	77.96	.....	.....

Pressure in Pounds per Sq. In. and Equivalent Head of Water in Feet

Pounds per sq. in.	Feet head	Pounds per sq. in.	Feet head	Pounds per sq. in.	Feet head
1	2.31	55	126.99	180	415.61
2	4.62	60	138.54	190	438.90
3	6.93	65	150.08	200	461.78
4	9.24	70	161.63	225	519.51
5	11.54	75	173.17	250	577.24
6	13.85	80	184.72	275	643.03
7	16.16	85	196.26	300	692.69
8	18.47	90	207.81	325	750.41
9	20.78	95	219.35	350	808.13
10	23.09	100	230.90	375	865.89
15	34.63	110	253.98	400	922.58
20	46.18	120	277.07	500	1154.48
25	57.72	125	288.62	.....	.....
30	69.27	130	300.16	.....	.....
35	80.81	140	323.25	.....	.....
40	92.36	150	346.34	.....	.....
45	103.90	160	369.43	.....	.....
50	115.45	170	392.52	.....	.....

TABLE 3.—DISCHARGE EQUIVALENTS

Gallons per min.	Cubic feet per sec.	Cubic feet per min.	Gallons per hour	Gallons per 24 hours	Bbls. per minute, 42 gal. bbl.	Bbls. per hour, 42 gal. bbl.	Bbls. per 24 hours, 42 gal. bbl.
10		1.3368	600	14,400	0.24	14.28	342.8
12		1.6042	720	17,280	0.29	17.14	411.4
15		2.0052	900	21,600	0.36	21.43	514.3
18		2.4063	1,080	25,920	0.43	25.71	617.1
20		2.6733	1,200	28,800	0.48	28.57	685.7
25		3.342	1,500	36,000	0.59	35.71	857.0
27		3.609	1,620	38,880	0.64	38.57	925.0
30		4.001	1,800	43,200	0.71	42.85	1,028.0
35		4.678	2,100	50,400	0.83	50.0	1,200.0
36		4.812	2,160	51,840	0.86	51.43	1,234.0
40		5.348	2,400	57,600	0.95	57.14	1,371.0
45	0.1	6.015	2,700	64,800	1.07	64.28	1,543.0
50		6.684	3,000	72,000	1.19	71.43	1,714.0
60		8.021	3,600	86,400	1.43	85.71	2,057.0
70		9.357	4,200	100,800	1.66	100.0	2,400.0
75		10.026	4,500	108,000	1.78	107.14	2,570.0
80		10.694	4,800	115,200	1.90	114.28	2,742.0
90	0.2	12.031	5,400	129,600	2.14	128.5	3,085.0
100		13.368	6,000	144,000	2.39	142.8	3,428.0
125		16.710	7,500	180,000	2.98	178.6	4,286.0
135	0.3	18.046	8,100	194,400	3.21	192.8	4,628.0
150		20.052	9,000	216,000	3.57	214.3	5,143.0
175		23.394	10,500	252,000	4.16	250.0	6,000.0
180	0.4	24.062	10,800	259,200	4.28	257.0	6,171.0
200		26.736	12,000	288,000	4.76	285.7	6,857.0
225	0.5	30.079	13,500	324,000	5.35	321.4	7,714.0
250		33.421	15,000	360,000	5.95	357.1	8,570.0
270	0.6	36.093	16,200	388,800	6.43	385.7	9,257.0
300		40.104	18,000	432,000	7.14	428.5	10,284.0
315		42.109	18,900	453,600	7.5	450.0	10,800.0
360	0.8	48.125	21,600	518,400	8.57	514.3	12,342.0
400		53.472	24,000	576,000	9.52	571.8	13,723.0
450	1.0	60.158	27,000	648,000	10.7	642.8	15,428.0
500		66.842	30,000	720,000	11.9	714.3	17,143.0
540	1.2	72.186	32,400	777,600	12.8	771.3	18,512.0
600		80.208	36,000	864,000	14.3	857.1	20,570.0
630	1.4	84.218	37,800	907,200	15.0	900.0	21,600.0
675	1.5	90.234	40,500	972,000	16.0	964.0	23,143.0
720	1.6	96.25	43,200	1,036,800	17.0	1,028.0	24,685.0
800		106.94	48,000	1,152,000	19.05	1,142.0	27,387.0
900	2.0	120.31	54,000	1,296,000	21.43	1,285.0	30,857.0
1,000		133.68	60,000	1,440,000	23.8	1,428.0	34,284.0
1,125	2.5	150.39	67,500	1,620,000	26.78	1,607.0	38,571.0
1,200		160.42	72,000	1,728,000	28.57	1,714.0	41,143.0
1,350	3.0	180.46	81,000	1,944,000	32.14	1,928.0	46,085.0
1,500		200.52	90,000	2,160,000	35.71	2,142.0	51,427.0
1,575	3.5	210.54	94,500	2,268,000	37.5	2,250.0	54,000.0
1,800	4.0	240.62	108,000	2,592,000	42.85	2,571.0	61,710.0
2,000		267.36	120,000	2,880,000	47.64	2,857.0	68,568.0
2,025	4.5	270.70	121,500	2,916,000	48.21	2,892.0	69,425.0
2,250		300.78	135,000	3,240,000	53.57	3,214.0	77,143.0
2,500		334.21	150,000	3,600,000	59.52	3,571.0	85,704.0
2,700	6.0	360.93	162,000	3,880,000	64.3	3,857.0	92,572.0
3,000		401.04	180,000	4,320,000	71.43	4,285.0	102,840.0

TABLE 4.—WEIGHTS AND MEASURES

Metric system		U. S. standard		Metric system		U. S. standard	
Length		Length		Weight		Weight	
1 millimeter = 0.0394 inches	1 inch = 2.5399 centimeters	1 gram = 15.4323 grains	1 lb. = 0.4536 kilos	1 kilogram = 2.2046 lb.	1 cwt. = 50.8024 kilos	1 pint = 55.0661 centiliters	1 qt. = 1.1013 liters
1 centimeter = 0.3937 inches	1 foot = 30.4794 centimeters	1 tonneau = 2204.55 lb.	1 ton = 1016.0483 kilos			1 quart = 0.908 quarts	1 bushel = 35.2416 liters
1 meter = 39.3708 inches	1 yard = 0.9143 meters						
1 kilometer = 0.6214 miles	1 mile = 1.6093 kilometers						
Area		Area		Dry measure		Dry measure	
1 sq. centimeter = 0.1549 sq. in.	1 sq. in. = 6.4513 sq. centimeters	1 centiliter = 0.0181 pints	1 pint = 55.0661 centiliters	1 liter = 0.908 quarts	1 quart = 1.1013 liters		
1 sq. meter = 10.7631 sq. ft.	1 sq. ft. = 0.0929 sq. meters	1 hectoliter = 2.837 bushels					
1 are = 119.5894 sq. yd.	1 sq. yd. = 0.8361 sq. meters						
1 hectare = 2.4711 acres	1 acre = 0.4047 hectares						
Volume		Volume		Liquid measure		Liquid measure	
1 cubic meter = 35.3166 cu. ft.	1 cubic foot = 0.02831 cubic meters	1 centiliter = 0.0211 pints	1 pint = 47.3171 centiliters	1 liter = 1.0567 quarts	1 quart = 0.9563 liters		
		1 hectoliter = 26.4176 gallons	1 gallon = 3.7854 liters				

1 U. S. ton of shipping = 40 cubic feet = 32.143 U. S. bushels = 1.1326 cubic meters.

EQUIVALENTS OF VARIOUS WEIGHTS AND MEASURES

	U. S. gallon	Imperial gallon	Cubic inch	Cubic foot	Pound	Cwt.	Ton	Liter	Cubic meter
U. S. gallon.....	1.0	0.83	231.0	0.133	8.33	0.07455	0.00372	3.8	0.00378
Imperial gallon.....	1.2	1.0	277.274	0.16	10.0	0.0892	0.00446	4.537	0.00454
Cubic inch.....	0.004329	0.003607	1.0	0.00058	0.03607	.....	.....	0.0163	.....
Cubic foot.....	7.48	6.23	1728.0	1.0	62.35	0.557	0.028	28.375	0.0283
Pound.....	0.083	0.10	27.72	0.016	1.0	112.0	2240.0	.....	.....
Cwt.....	13.44	11.2	.....	.....	.....	1.0	20.0	.....	.....
Ton.....	268.8	224.0	.....	.....	.....	0.05	.....	1000.0	1.0
Liter.....	0.264	0.22	61.0	0.0353	.....	.....	0.001	1.0	0.001
Cubic meter.....	264.0	220.0	61028.0	35.31	.....	.....	1.0	1000.0	1.0

TABLE 5.—SPECIFIC WEIGHTS OF VARIOUS SUBSTANCES

Air, press. 76 cm. Hg., 0° C.....	0.001293	Iron, cast.....	7.03- 7.73
Alcohol.....	0.79	pure.....	7.85- 7.88
Aluminium, pure.....	2.583	steel.....	7.60- 7.80
commercial.....	2.7 - 2.8	wrought.....	7.79- 7.85
Basalt.....	2.4 - 3.3	Lead.....	11.21-11.45
Bismuth.....	9.76- 9.93	Lime mortar.....	1.6 - 1.8
Brass.....	7.8 - 8.7	Limestone.....	2.4 - 2.8
Brick.....	1.4 - 2.3	Magnesium.....	1.69- 1.75
Cadmium.....	8.54- 8.69	Marble.....	2.5 - 2.9
Carbon, charcoal.....	1.45- 1.70	Mercury at 0° C.....	13.596
diamond.....	3.49- 3.53	Nickel.....	8.57- 8.93
graphite.....	2.17- 2.32	Oil.....	0.91- 0.94
Coal, hard.....	1.2 - 1.8	Platinum, cast.....	21.48-21.50
Copper, cast.....	8.3 - 8.92	wire and foil.....	21.2 -21.7
electrolytic.....	8.88- 8.95	Quartz.....	2.3 - 2.7
wire.....	8.93- 8.95	Rubber.....	0.93
Cork.....	0.24	Sand.....	1.2 - 1.9
Earth.....	1.4 - 2.8	Sandstone.....	1.9 - 2.7
Gold.....	19.30-19.34	Seawater.....	1.02- 1.03
Glass.....	2.5 - 3.8	Silver.....	10.42-10.57
Granite.....	2.5 - 3.0	Timber, oak.....	0.62- 1.17
Hydrogen, press. 76 cm. Hg., 0° C.....	0.0000894	fir.....	0.5 - 0.9
Ice.....	0.926	poplar.....	0.35- 1.02
		Tin.....	6.97- 7.37
		Zinc.....	6.86- 7.24

TABLE 6.—STANDARD DIMENSIONS OF WROUGHT IRON AND STEEL, STEAM, GAS, AND WATER PIPE

Diameter			Nominal thickness		Circumference		Cross-sectional area			Length of pipe per square foot of			Length of pipe containing 1 cubic ft.		Nominal weight per foot
Nominal internal	Actual external	Approximate internal	Inches		External	Internal	Sq. In.	External	Internal	Metal	Feet		Feet	Pounds	
			Inches	Inches							External surface	Internal surface			
1/8	0.405	0.27	0.068	0.848	0.129	0.0573	0.0717	9.44	14.15	0.0717	9.44	14.15	2513.0	0.241	
1/4	0.54	0.364	0.088	1.144	0.229	0.1041	0.1249	7.075	10.49	0.1249	7.075	10.49	1383.3	0.42	
3/8	0.675	0.494	0.091	1.552	0.358	0.1917	0.1663	5.657	7.73	0.1663	5.657	7.73	751.2	0.559	
1/2	0.84	0.623	0.109	2.639	0.554	0.3048	0.2492	4.547	6.13	0.3048	4.547	6.13	472.4	0.837	
3/4	1.05	0.824	0.113	3.299	0.866	0.5333	0.3327	3.637	4.635	0.5333	3.637	4.635	270.0	1.115	
1	1.315	1.048	0.134	4.131	1.358	0.8626	0.4954	2.904	3.645	0.8626	2.904	3.645	166.9	1.668	
1-1/4	1.66	1.38	0.14	5.215	2.104	1.496	0.668	2.301	2.768	1.496	2.301	2.768	96.25	2.244	
1-1/2	1.9	1.611	0.145	5.969	2.835	2.038	0.797	2.01	2.371	2.038	2.01	2.371	70.66	2.678	
2	2.375	2.067	0.154	7.461	4.43	3.356	1.074	1.608	1.848	1.074	1.608	1.848	42.91	3.609	
2-1/2	2.875	2.468	0.204	9.032	6.492	4.784	1.708	1.328	1.547	1.708	1.328	1.547	30.1	5.739	
3	3.5	3.067	0.217	10.996	9.621	7.388	2.243	1.091	1.245	2.243	1.091	1.245	19.5	7.536	
3-1/2	4.0	3.548	0.226	12.566	12.566	9.887	2.679	0.955	1.077	2.679	0.955	1.077	14.57	9.001	
4	4.5	4.026	0.237	14.137	15.904	12.73	3.174	0.849	0.949	3.174	0.849	0.949	11.31	10.665	
4-1/2	5.0	4.508	0.246	15.708	14.162	15.961	3.764	0.764	0.848	3.764	0.764	0.848	9.02	12.49	
5	5.563	5.045	0.259	17.477	15.849	19.99	4.316	0.687	0.757	4.316	0.687	0.757	7.2	14.502	
6	6.625	6.065	0.28	20.813	19.054	28.888	5.584	0.577	0.63	5.584	0.577	0.63	4.98	18.762	
7	7.625	7.023	0.301	23.955	22.063	38.738	6.926	0.501	0.544	6.926	0.501	0.544	3.72	23.271	
8	8.625	7.982	0.322	27.096	25.076	50.04	8.386	0.443	0.478	8.386	0.443	0.478	2.88	28.177	
9	9.625	8.937	0.344	30.238	28.076	62.73	10.03	0.397	0.427	10.03	0.397	0.427	2.29	33.701	
10	10.75	10.019	0.366	33.772	31.477	79.763	11.924	0.355	0.382	11.924	0.355	0.382	1.82	40.065	
11	11.75	11.0	.....	36.914	34.558	108.434	13.401	0.325	0.347	13.401	0.325	0.347	1.51	45.028	
12	12.75	12.0	.....	40.055	37.7	127.677	14.759	0.299	0.319	14.759	0.299	0.319	1.27	48.985	

TABLE 7.—CAPACITY OF RECIPROCATING PUMPS

Capacity, or piston displacement, of reciprocating pumps in gallons per single stroke

Diameter of cylinder, inches	Length of stroke in inches								
	2	3	4	5	6	7	8	9	10
1-1/4	0.0106	0.0159	0.0212	0.0266	0.0319	0.0372	0.0425	0.0478	0.0531
1-3/8	0.0128	0.0192	0.0256	0.0321	0.0385	0.0449	0.0513	0.0578	0.0642
1-1/2	0.0153	0.0229	0.0306	0.0382	0.0459	0.0535	0.0612	0.0688	0.0765
1-3/4	0.0208	0.0312	0.0416	0.0521	0.0625	0.0729	0.0833	0.0937	0.1041
2	0.0272	0.0408	0.0544	0.068	0.0816	0.0952	0.1088	0.1224	0.136
2-1/4	0.0344	0.0516	0.0688	0.086	0.1033	0.1205	0.1377	0.1548	0.1721
2-1/2	0.0425	0.0637	0.0850	0.1062	0.1275	0.1487	0.17	0.1912	0.2125
2-3/4	0.0514	0.0771	0.1028	0.1285	0.1543	0.1799	0.2057	0.2313	0.2571
3	0.0612	0.0918	0.1224	0.1530	0.1836	0.2142	0.2448	0.2754	0.306
3-1/4	0.0718	0.1077	0.1436	0.1795	0.2154	0.2513	0.2872	0.3231	0.3594
3-1/2	0.0833	0.1249	0.1666	0.2082	0.2499	0.2915	0.3332	0.3748	0.4165
3-3/4	0.0956	0.1434	0.1912	0.239	0.2868	0.3346	0.3824	0.4302	0.478
4	0.1088	0.1632	0.2176	0.272	0.3264	0.3808	0.4352	0.4896	0.544
4-1/4	0.1228	0.1842	0.2456	0.307	0.3684	0.4298	0.4912	0.5526	0.6141
4-1/2	0.1377	0.2065	0.2754	0.3442	0.4131	0.4819	0.5508	0.6196	0.6885
4-3/4	0.1534	0.2301	0.3068	0.3835	0.4602	0.5369	0.6136	0.6903	0.7671
5	0.17	0.2550	0.34	0.425	0.51	0.595	0.68	0.765	0.85
5-1/4	0.1874	0.2811	0.3748	0.4685	0.5622	0.6559	0.7496	0.8433	0.9371
5-1/2	0.2057	0.3085	0.4114	0.5142	0.6171	0.7199	0.8228	0.9256	1.0285
5-3/4	0.2248	0.3372	0.4496	0.562	0.6744	0.7868	0.8992	1.011	1.124
6	0.2448	0.3672	0.4896	0.612	0.7344	0.8568	0.9792	1.1016	1.2240
6-1/4	0.2656	0.3984	0.5312	0.6640	0.7968	0.9296	1.062	1.195	1.328
6-1/2	0.2872	0.4308	0.5744	0.7182	0.8610	1.0052	1.1488	1.2926	1.4364
6-3/4	0.3098	0.4647	0.6196	0.7745	0.9294	1.084	1.239	1.394	1.549
7	0.3332	0.4998	0.6664	0.833	0.9996	1.1662	1.3328	1.4994	1.666
7-3/4	0.4084	0.6126	0.8168	1.021	1.225	1.429	1.633	1.837	2.042
8	0.4352	0.6528	0.8704	1.088	1.3056	1.5232	1.7408	1.9584	2.176
9	0.5508	0.8262	1.1010	1.377	1.6524	1.9278	2.2032	2.4786	2.754
10	0.68	1.02	1.36	1.7	2.04	2.38	2.72	3.06	3.4
11	0.8227	1.2341	1.6451	2.057	2.464	2.879	3.2911	3.7258	4.1139
12	0.9792	1.468	1.9584	2.448	2.9376	3.4222	3.9168	4.4064	4.896
13	1.149	1.723	2.297	2.872	3.445	4.022	4.596	5.170	5.745
14	1.332	1.998	2.665	3.331	3.997	4.664	5.33	5.996	6.663
15	1.529	2.294	3.059	3.824	4.589	5.354	6.119	6.884	7.649
16	1.74	2.61	3.48	4.35	5.22	6.09	6.96	7.83	8.703
18	2.202	3.303	4.404	5.505	6.606	7.707	8.808	9.909	11.01
20	2.720	4.08	5.440	6.8	8.16	9.52	10.88	12.24	13.6



TABLE 7.—CAPACITY OF RECIPROCATING PUMPS—(Continued)

Diameter of cylinder, inches	Length of stroke in inches							
	12	14	15	16	18	20	22	24
1-1/4	0.0637	0.0743	0.0797	0.0848	0.0955	0.1062	0.1168	0.1274
1-3/8	0.077	0.089	0.0963	0.1027	0.1156	0.1280	0.1408	0.1541
1-1/2	0.0918	0.1071	0.1147	0.1224	0.1377	0.1530	0.1683	0.1836
1-3/4	0.1249	0.1457	0.1562	0.1666	0.1874	0.2082	0.2290	0.2499
2	0.1632	0.1904	0.204	0.2176	0.2448	0.2720	0.2992	0.3264
2-1/4	0.2063	0.241	0.258	0.2754	0.3096	0.344	0.3784	0.4128
2-1/2	0.255	0.2975	0.3187	0.34	0.3825	0.4252	0.4677	0.51
2-3/4	0.3085	0.3598	0.3855	0.4114	0.4626	0.5142	0.5656	0.617
3	0.3672	0.4284	0.459	0.4896	0.5508	0.612	0.6732	0.7344
3-1/4	0.4312	0.503	0.5385	0.5748	0.6466	0.7182	0.79	0.8624
3-1/2	0.4998	0.5831	0.6247	0.6664	0.7497	0.833	0.9163	0.9996
3-3/4	0.5736	0.6692	0.687	0.7648	0.8605	0.9561	1.0517	1.147
4	0.6528	0.7616	0.816	0.8904	0.9792	1.088	1.1968	1.3056
4-1/4	0.7368	0.8596	0.921	0.9824	1.105	1.228	1.3508	1.473
4-1/2	0.8262	0.9639	1.0327	1.1016	1.2393	1.377	1.5147	1.6524
4-3/4	0.9204	1.073	1.15	1.227	1.380	1.534	1.6874	1.84
5	1.02	1.19	1.275	1.36	1.53	1.7	1.87	2.04
5-1/4	1.124	1.311	1.405	1.499	1.686	1.874	2.0614	2.248
5-1/2	1.2342	1.4399	1.5427	1.6456	1.8513	2.057	2.2627	2.4684
5-3/4	1.348	1.573	1.686	1.789	2.022	2.248	2.4728	2.696
6	1.4688	1.7136	1.8362	1.9584	2.2032	2.448	2.6928	2.9376
6-1/4	1.593	1.859	1.992	2.124	2.39	2.656	2.9216	3.186
6-1/2	1.7955	2.0109	2.1546	2.2982	2.5885	2.8728	3.16	3.4473
6-3/4	1.858	2.168	2.323	2.479	2.788	3.098	3.4078	3.716
7	1.9992	2.3324	2.499	2.6656	2.9988	3.332	3.6652	3.9984
7-3/4	2.45	2.858	3.063	3.266	3.674	4.084	4.4924	4.9
8	2.6112	3.0464	3.264	3.4816	3.9168	4.352	4.7872	5.2224
9	3.3048	3.8556	4.131	4.4064	5.0572	5.508	6.0588	6.6096
10	4.08	4.76	5.1	5.44	6.12	6.8	7.48	8.16
11	4.9367	5.7595	6.1709	6.5823	7.4051	8.2279	9.0506	9.8735
12	5.8752	6.8544	7.344	7.833	8.8128	9.792	10.7712	11.7504
13	6.894	8.042	8.616	9.192	10.34	11.49	12.639	13.78
14	7.994	9.328	9.993	10.66	11.99	13.32	14.652	15.98
15	9.178	10.70	11.47	12.23	13.76	15.29	16.819	18.35
16	10.44	12.18	13.05	13.92	15.66	17.40	19.14	20.88
18	13.21	15.41	16.51	17.61	19.81	22.02	24.22	26.42
20	16.32	19.04	20.4	21.76	24.48	27.2	29.92	32.6

TABLE 8.—CIRCUMFERENCES AND AREAS OF CIRCLES

Diameters, 1/16 in. up to and including 120 in. Advancing, 1/16 to 1; 1/8 to 50; 1/4 to 80, and 1/2 to 120

Diameter, inches	Circumference, inches	Area, square inches	Diameter, inches	Circumference, inches	Area, square inches	Diameter, inches	Circumference, inches	Area, square inches
1/16	0.19635	0.00307	4-1/2	14.137	15.904	9-5/8	30.237	72.759
1/8	0.3927	0.01227	4-5/8	14.529	16.800	9-3/4	30.630	74.662
3/16	0.5890	0.02761	4-3/4	14.922	17.720	9-7/8	31.023	76.588
1/4	0.7854	0.04909	4-7/8	15.315	18.665	10	31.416	78.540
5/16	0.9817	0.07670				10-1/8	31.808	80.515
3/8	1.1781	0.1104	5	15.708	19.635	10-1/4	32.201	82.516
7/16	1.3744	0.1503	5-1/8	16.100	20.629	10-3/8	32.594	84.540
1/2	1.5708	0.1963	5-1/4	16.493	21.647	10-1/2	32.986	86.590
9/16	1.7771	0.2485	5-3/8	16.886	22.690	10-5/8	33.379	88.664
5/8	1.9635	0.3068	5-1/2	17.278	23.758	10-3/4	33.772	90.762
11/16	2.1598	0.3712	5-5/8	17.671	24.850	10-7/8	34.164	92.885
3/4	2.3562	0.4417	5-3/4	18.064	25.967	11	34.558	95.033
13/16	2.5525	0.5185	5-7/8	18.457	27.108	11-1/8	34.950	97.205
7/8	2.7489	0.6013				11-1/4	35.343	99.402
15/16	2.9452	0.6903	6	18.849	28.274	11-3/8	35.735	101.623
1	3.1416	0.7854	6-1/8	19.242	29.464	11-1/2	36.128	103.869
1-1/8	3.5343	0.9940	6-1/4	19.635	30.679	11-5/8	36.521	106.139
1-1/4	3.9270	1.2271	6-3/8	20.027	31.919	11-3/4	36.913	108.434
1-3/8	4.3197	1.4848	6-1/2	20.420	33.183	11-7/8	37.306	110.753
1-1/2	4.7124	1.7671	6-5/8	20.813	34.471	12	37.699	113.097
1-5/8	5.1051	2.0739	6-3/4	21.205	35.784	12-1/8	38.091	115.466
1-3/4	5.4978	2.4052	6-7/8	21.598	37.122	12-1/4	38.484	117.859
1-7/8	5.8905	2.7621				12-3/8	38.877	120.276
2	6.2832	3.1416	7-1/8	21.991	38.484	12-1/2	39.270	122.718
2-1/8	6.6759	3.5465	7-1/4	22.383	39.871	12-5/8	39.662	125.184
2-1/4	7.0686	3.9760	7-3/8	22.776	41.282	12-3/4	40.055	127.676
2-3/8	7.4613	4.4302	7-1/2	23.169	42.718	12-7/8	40.448	130.192
2-1/2	7.8540	4.9087	7-5/8	23.562	44.178	13	40.840	132.732
2-5/8	8.2467	5.4119	7-3/4	23.954	45.663	13-1/8	41.233	135.297
2-3/4	8.6394	5.9395	7-7/8	24.347	47.173	13-1/4	41.626	137.886
2-7/8	9.0321	6.4918				13-3/8	42.018	140.500
3	9.4248	7.0686	8	25.132	50.265	13-1/2	42.411	143.139
3-1/8	9.8175	7.6699	8-1/8	25.515	51.848	13-5/8	42.804	145.802
3-1/4	10.210	8.2957	8-1/4	25.918	53.456	13-3/4	43.197	148.489
3-3/8	10.602	8.9462	8-3/8	26.310	55.088	13-7/8	43.589	151.201
3-3/4	11.000	9.6211	8-1/2	26.703	56.745	14	43.982	153.938
3-1/2	10.995	9.6211	8-5/8	27.096	58.426	14-1/8	44.375	156.699
3-5/8	11.388	10.320	8-3/4	27.489	60.132	14-1/4	44.767	159.485
3-3/4	11.781	11.044	8-7/8	27.881	61.862	14-3/8	45.160	162.295
3-7/8	12.173	11.793				14-1/2	45.553	165.130
4	12.566	12.566	9	28.274	63.617	14-5/8	45.945	167.989
4-1/8	12.959	13.364	9-1/8	28.667	65.396	14-3/4	46.338	170.873
4-1/4	13.351	14.186	9-1/4	29.059	67.200	14-7/8	46.731	173.782
4-3/8	13.744	15.033	9-3/8	29.452	69.029			
			9-1/2	29.845	70.882			

TABLE 8.—CIRCUMFERENCES AND AREAS OF CIRCLES—(Continued)

Diameter inches	Circumference inches	Area square inches	Diameter inches	Circumference inches	Area square inches	Diameter inches	Circumference inches	Area square inches
15	47.124	176.715	21	65.973	346.361	27	84.823	572.556
15-1/8	47.516	179.672	21-1/8	66.366	350.497	27-1/8	85.215	577.870
15-1/4	47.909	182.654	21-1/4	66.759	354.657	27-1/4	85.608	583.208
15-3/8	48.302	185.661	21-3/8	67.151	358.841	27-3/8	86.001	588.571
15-1/2	48.694	188.692	21-1/2	67.544	363.061	27-1/2	86.394	593.958
15-5/8	49.087	191.748	21-5/8	67.937	367.284	27-5/8	86.786	599.370
15-3/4	49.480	194.828	21-3/4	68.329	371.543	27-3/4	87.179	604.807
15-7/8	49.872	197.933	21-7/8	68.722	375.826	27-7/8	87.572	610.268
16	50.265	201.062	22	69.115	380.133	28	87.964	615.753
16-1/8	50.658	204.216	22-1/8	69.507	384.465	28-1/8	88.357	621.263
16-1/4	51.051	207.394	22-1/4	69.900	388.822	28-1/4	88.750	626.798
16-3/8	51.443	210.597	22-3/8	70.293	393.203	28-3/8	89.142	632.357
16-1/2	51.836	213.825	22-1/2	70.686	397.608	28-1/2	89.535	637.941
16-5/8	52.229	217.077	22-5/8	71.078	402.038	28-5/8	89.928	643.594
16-3/4	52.621	220.353	22-3/4	71.471	406.493	28-3/4	90.321	649.182
16-7/8	53.014	223.654	22-7/8	71.864	410.972	28-7/8	90.713	654.837
17	53.407	226.980	23	72.256	415.476	29	91.106	660.521
17-1/8	53.799	230.330	23-1/8	72.649	420.004	29-1/8	91.499	666.277
17-1/4	54.192	233.705	23-1/4	73.042	424.557	29-1/4	91.891	671.958
17-3/8	54.585	237.104	23-3/8	73.434	429.135	29-3/8	92.284	677.714
17-1/2	54.978	240.528	23-1/2	73.827	433.731	29-1/2	92.677	683.494
17-5/8	55.370	243.977	23-5/8	74.220	438.363	29-5/8	93.069	689.298
17-3/4	55.763	247.450	23-3/4	74.613	443.014	29-3/4	93.462	695.128
17-7/8	56.156	250.947	23-7/8	75.005	447.699	29-7/8	93.855	700.981
18	56.548	254.469	24	75.398	452.390	30	94.248	706.860
18-1/8	56.941	258.016	24-1/8	75.791	457.115	30-1/8	94.640	712.762
18-1/4	57.334	261.586	24-1/4	76.183	461.864	30-1/4	95.033	718.690
18-3/8	57.726	265.182	24-3/8	76.576	466.638	30-3/8	95.426	724.641
18-1/2	58.119	268.803	24-1/2	76.969	471.436	30-1/2	95.818	730.618
18-5/8	58.512	272.447	24-5/8	77.361	476.259	30-5/8	96.211	736.619
18-3/4	58.905	276.117	24-3/4	77.754	481.106	30-3/4	96.604	742.644
18-7/8	59.297	279.811	24-7/8	78.147	485.978	30-7/8	96.996	748.694
19	59.690	283.529	25	78.540	490.875	31	97.389	754.769
19-1/8	60.083	287.272	25-1/8	78.932	495.796	31-1/8	97.782	760.868
19-1/4	60.475	291.039	25-1/4	79.325	500.741	31-1/4	98.175	766.992
19-3/8	60.868	294.831	25-3/8	79.718	505.711	31-3/8	98.567	773.140
19-1/2	61.261	298.648	25-1/2	80.110	510.706	31-1/2	98.968	779.313
19-5/8	61.653	302.489	25-5/8	80.503	515.725	31-5/8	99.353	785.510
19-3/4	62.046	306.355	25-3/4	80.896	520.769	31-3/4	99.745	791.732
19-7/8	62.439	310.245	25-7/8	81.288	525.837	31-7/8	100.138	797.978
20	62.832	314.160	26	81.681	530.930	32	100.531	804.249
20-1/8	63.224	318.099	26-1/8	82.074	536.047	32-1/8	100.924	810.545
20-1/4	63.617	322.063	26-1/4	82.467	541.189	32-1/4	101.316	816.865
20-3/8	64.010	326.051	26-3/8	82.859	546.356	32-3/8	101.709	823.209
20-1/2	64.402	330.064	26-1/2	83.252	551.547	32-1/2	102.102	829.578
20-5/8	64.795	334.101	26-5/8	83.645	556.762	32-5/8	102.494	835.972
20-3/4	65.188	338.163	26-3/4	84.037	562.002	32-3/4	102.887	842.390
20-7/8	65.580	342.250	26-7/8	84.430	567.267	32-7/8	103.280	848.833

## CIRCUMFERENCES AND AREAS OF CIRCLES—(Continued)

Diameter inches	Circumference inches	Area square inches	Diameter inches	Circumference inches	Area square inches	Diameter inches	Circumference inches	Area square inches
33	103.672	855.30	39	122.522	1194.59	45	141.372	1590.43
33-1/8	104.055	861.79	39-1/8	122.915	1202.26	45-1/8	141.764	1599.28
33-1/4	104.458	868.30	39-1/4	123.307	1209.95	45-1/4	142.157	1608.15
33-3/8	104.850	874.84	39-3/8	123.700	1217.67	45-3/8	142.550	1617.04
33-1/2	105.243	881.41	39-1/2	124.093	1225.42	45-1/2	142.942	1625.97
33-5/8	105.636	888.00	39-5/8	124.485	1233.18	45-5/8	143.335	1634.92
33-3/4	106.029	894.61	39-3/4	124.878	1240.98	45-3/4	143.728	1643.89
33-7/8	106.421	901.25	39-7/8	125.271	1248.79	45-7/8	144.120	1652.88
34	106.814	907.92	40	125.664	1256.64	46	144.513	1661.90
34-1/8	107.207	914.61	40-1/8	126.056	1264.50	46-1/8	144.906	1670.95
34-1/4	107.599	921.32	40-1/4	126.449	1272.39	46-1/4	145.299	1680.01
34-3/8	107.992	928.06	40-3/8	126.842	1280.31	46-3/8	145.691	1689.10
34-1/2	108.385	934.82	40-1/2	127.234	1288.25	46-1/2	146.084	1698.23
34-5/8	108.777	941.60	40-5/8	127.627	1296.21	46-5/8	146.477	1707.37
34-3/4	109.170	948.41	40-3/4	128.020	1304.20	46-3/4	146.869	1716.54
34-7/8	109.563	955.25	40-7/8	128.412	1312.21	46-7/8	147.262	1725.73
35	109.956	962.11	41	128.805	1320.25	47	147.655	1734.94
35-1/8	110.348	968.99	41-1/8	129.198	1328.32	47-1/8	148.047	1744.18
35-1/4	110.741	975.90	41-1/4	129.591	1336.40	47-1/4	148.440	1753.45
35-3/8	111.134	982.84	41-3/8	129.983	1344.51	47-3/8	148.833	1762.73
35-1/2	111.526	989.80	41-1/2	130.376	1352.65	47-1/2	149.226	1772.05
35-5/8	111.919	996.78	41-5/8	130.769	1360.81	47-5/8	149.618	1781.39
35-3/4	112.312	1003.78	41-3/4	131.161	1369.00	47-3/4	150.011	1790.76
35-7/8	112.704	1010.82	41-7/8	131.554	1377.21	47-7/8	150.404	1800.14
36	113.097	1017.88	42	131.947	1385.44	48	150.796	1809.56
36-1/8	113.490	1024.95	42-1/8	132.339	1393.70	48-1/8	151.189	1818.99
36-1/4	113.883	1032.06	42-1/4	132.732	1401.98	48-1/4	151.582	1828.46
36-3/8	114.275	1039.19	42-3/8	133.125	1410.29	48-3/8	151.974	1837.93
36-1/2	114.668	1046.35	42-1/2	133.518	1418.62	48-1/2	152.367	1847.45
36-5/8	115.061	1053.52	42-5/8	133.910	1426.98	48-5/8	152.760	1856.99
36-3/4	115.453	1060.73	42-3/4	134.303	1435.36	48-3/4	153.153	1866.55
36-7/8	115.846	1067.95	42-7/8	134.696	1443.77	48-7/8	153.545	1876.13
37	116.239	1075.21	43	135.088	1452.20	49	153.938	1885.74
37-1/8	116.631	1082.48	43-1/8	135.481	1460.65	49-1/8	154.331	1895.37
37-1/4	117.024	1089.79	43-1/4	135.874	1469.13	49-1/4	154.723	1905.03
37-3/8	117.417	1097.11	43-3/8	136.266	1477.63	49-3/8	155.116	1914.70
37-1/2	117.810	1104.46	43-1/2	136.659	1486.17	49-1/2	155.509	1924.42
37-5/8	118.202	1111.84	43-5/8	137.052	1494.72	49-5/8	155.901	1934.15
37-3/4	118.595	1119.24	43-3/4	137.445	1503.30	49-3/4	156.294	1943.91
37-7/8	118.988	1126.66	43-7/8	137.837	1511.90	49-7/8	156.687	1953.69
38	119.380	1134.11	44	138.230	1520.53	50	157.080	1963.50
38-1/8	119.773	1141.59	44-1/8	138.623	1529.18	50-1/8	157.473	1973.35
38-1/4	120.166	1149.08	44-1/4	139.015	1537.86	50-1/4	157.865	1983.18
38-3/8	120.558	1156.61	44-3/8	139.408	1546.55	50-3/8	158.257	1993.04
38-1/2	120.951	1164.15	44-1/2	139.801	1555.28	51	160.221	2002.84
38-5/8	121.344	1171.73	44-5/8	140.193	1564.03	51-1/8	160.613	2012.67
38-3/4	121.737	1179.32	44-3/4	140.586	1572.81	51-1/4	161.007	2022.54
38-7/8	122.129	1186.94	44-7/8	140.979	1581.61	51-3/8	161.401	2032.44

## CIRCUMFERENCES AND AREAS OF CIRCLES—(Continued)

Diame- ter inches	Circum- ference inches	Area square inches	Diame- ter inches	Circum- ference inches	Area square inches	Diame- ter inches	Circum- ference inches	Area square inches
52	163.363	2123.72	63	197.920	3117.25	74	232.478	4300.84
52-1/4	164.148	2144.19	63-1/4	198.706	3142.04	74-1/4	233.263	4329.95
52-1/2	164.934	2164.75	63-1/2	199.491	3166.92	74-1/2	234.049	4359.16
52-3/4	165.719	2185.42	63-3/4	200.277	3191.91	74-3/4	234.834	4388.47
53	166.504	2206.18	64	201.062	3216.99	75	235.620	4417.86
53-1/4	167.490	2227.05	64-1/4	201.847	3242.17	75-1/4	236.405	4447.37
53-1/2	168.075	2248.01	64-1/2	202.633	3267.46	75-1/2	237.190	4476.97
53-3/4	168.861	2269.06	64-3/4	203.418	3292.83	75-3/4	237.976	4506.67
54	169.646	2290.22	65	204.204	3318.31	76	238.761	4536.46
54-1/4	170.431	2311.48	65-1/4	204.989	3343.88	76-1/4	239.547	4566.36
54-1/2	171.217	2332.83	65-1/2	205.774	3369.56	76-1/2	240.332	4596.35
54-3/4	172.002	2354.28	64-3/4	206.560	3395.33	76-3/4	241.117	4626.44
55	172.788	2375.83	66	207.345	3421.19	77	241.903	4656.63
55-1/4	173.573	2397.48	66-1/4	208.131	3447.16	77-1/4	242.688	4686.92
55-1/2	174.358	2419.22	66-1/2	208.916	3473.33	77-1/2	243.474	4717.30
55-3/4	175.144	2441.07	66-3/4	209.701	3499.39	77-3/4	244.259	4747.79
56	175.929	2463.01	67	210.487	3525.66	78	245.044	4778.36
56-1/4	176.715	2485.05	67-1/4	211.272	3552.01	78-1/4	245.830	4809.05
56-1/2	177.500	2507.19	67-1/2	212.058	3578.47	78-1/2	246.615	4839.83
56-3/4	178.285	2529.42	67-3/4	212.843	3605.03	78-3/4	247.401	4870.70
57	179.071	2551.76	68	213.628	3631.68	79	248.186	4901.68
57-1/4	179.856	2574.19	68-1/4	214.414	3658.44	79-1/4	248.971	4932.75
57-1/2	180.642	2596.72	68-1/2	215.199	3685.29	79-1/2	249.757	4963.92
57-3/4	181.427	2619.35	68-3/4	215.985	3712.24	79-3/4	250.542	4995.19
58	182.212	2642.08	69	216.770	3739.28	80	251.328	5026.55
58-1/4	182.998	2664.91	69-1/4	217.555	3766.43	80-1/2	252.898	5089.58
58-1/2	183.783	2687.83	69-1/2	218.341	3793.67	81	254.469	5153.00
58-3/4	184.569	2710.85	69-3/4	219.126	3821.02	81-1/2	256.040	5216.82
59	185.354	2733.97	70	219.912	3848.45	82	257.611	5281.02
59-1/4	186.139	2757.19	70-1/4	220.697	3875.99	82-1/2	259.182	5345.62
59-1/2	186.925	2780.51	70-1/2	221.482	3903.63	83	260.752	5410.61
59-3/4	187.710	2803.92	70-3/4	222.268	3931.36	83-1/2	262.323	5476.00
60	188.496	2827.43	71	223.053	3959.19	84	263.894	5541.77
60-1/4	189.281	2851.05	71-1/4	223.839	3987.13	84-1/2	265.465	5607.95
60-1/2	190.066	2874.76	71-1/2	224.624	4015.16	85	267.035	5674.51
60-3/4	190.852	2898.56	71-3/4	225.409	4043.28	85-1/2	268.606	5741.47
61	191.637	2922.47	72	226.195	4071.50	86	270.177	5808.80
61-1/4	192.423	2946.47	72-1/4	226.980	4099.83	86-1/2	271.748	5876.55
61-1/2	193.208	2970.57	72-1/2	227.766	4128.25	87	273.319	5944.68
61-3/4	193.993	2994.77	72-3/4	228.551	4156.77	87-1/2	274.890	6013.21
62	194.779	3019.07	73	229.336	4185.39	88	276.460	6082.12
62-1/4	195.564	3043.47	73-1/4	230.122	4214.11	88-1/2	278.031	6151.44
62-1/2	196.350	3067.96	73-1/2	230.907	4242.92			
62-3/4	197.135	3092.56	73-3/4	231.693	4271.83			

## CIRCUMFERENCES AND AREAS OF CIRCLES—(Continued)

Diameter inches	Circum- ference inches	Area square inches	Diameter inches	Circum- ference inches	Area square inches	Diameter inches	Circum- ference inches	Area square inches
89	279.602	6221.14	100	314.159	7853.98	111	348.717	9766.89
89-1/2	281.173	6291.25	100-1/2	315.730	7938.72	111-1/2	350.288	9674.28
90	282.744	6361.73	101	317.301	8011.85	112	351.858	9852.03
90-1/2	284.314	6432.62	101-1/2	318.872	8091.36	112-1/2	353.430	9940.20
91	285.885	6503.88	102	320.442	8171.28	113	355.000	10028.75
91-1/2	287.456	6573.56	102-1/2	322.014	8251.60	113-1/2	356.570	10117.68
92	289.027	6647.61	103	323.584	8332.29	114	358.142	10207.03
92-1/2	290.598	6720.07	103-1/2	325.154	8413.40	114-1/2	359.712	10296.76
93	292.168	6792.91	104	326.726	8494.87	115	361.283	10386.89
93-1/2	293.739	6866.16	104-1/2	328.296	8576.76	115-1/2	362.854	10477.40
94	295.310	6939.78	105	329.867	8659.01	116	364.425	10568.32
94-1/2	296.881	7013.81	105-1/2	331.438	8741.68	116-1/2	365.996	10659.64
95	298.452	7088.22	106	333.009	8824.73	117	367.566	10751.32
95-1/2	300.022	7163.04	106-1/2	334.580	8908.20	117-1/2	369.138	10843.40
96	301.593	7238.23	107	336.150	8992.02	118	370.708	10935.88
96-1/2	302.164	7313.84	107-1/2	337.722	9076.24	118-1/2	372.278	11028.76
97	304.734	7389.81	108	339.292	9160.88	119	373.849	11122.02
97-1/2	306.306	7474.20	108-1/2	340.862	9245.92	119-1/2	375.420	11215.68
98	307.876	7542.96	109	342.434	9331.32	120	376.991	11309.73
98-1/2	309.446	7620.12	109-1/2	344.004	9417.12	.....	.....	.....
99	311.018	7697.69	110	345.575	9503.32	.....	.....	.....
99-1/2	312.588	7775.64	110-1/2	347.146	9589.92	.....	.....	.....

TABLE 9.<sup>1</sup>—EFFLUX COEFFICIENTS FOR CIRCULAR ORIFICE

Values of efflux coefficient  $K$  in Eq. (25), Art. 8,  $Q = 2/3Kb\sqrt{2g(H^{3/2} - h^{3/2})}$ , for circular, vertical orifices, with sharp edges, full contraction and free discharge in air.

For heads over 100 ft., use  $K = 0.592$ .

Head on center of orifice in feet	Diameter of orifice in feet												
	0.02	0.03	0.04	0.05	0.07	0.10	0.12	0.15	0.20	0.40	0.60	0.80	1.0
0.3	.....	.....	.....	0.637	0.628	0.621	0.613	0.608	.....	.....	.....	.....	.....
0.4	.....	.....	0.637	0.631	0.624	0.618	0.612	0.606	.....	.....	.....	.....	.....
0.5	.....	0.643	0.633	0.627	0.621	0.615	0.610	0.605	0.600	0.596	0.592	.....	.....
0.6	0.655	0.640	0.630	0.624	0.618	0.613	0.609	0.605	0.601	0.596	0.593	0.590	.....
0.7	0.651	0.637	0.628	0.622	0.616	0.611	0.607	0.604	0.601	0.597	0.594	0.591	0.590
0.8	0.648	0.634	0.626	0.620	0.615	0.610	0.606	0.603	0.601	0.597	0.594	0.592	0.591
0.9	0.646	0.632	0.624	0.618	0.613	0.609	0.605	0.603	0.601	0.598	0.595	0.593	0.591
1.0	0.644	0.631	0.623	0.617	0.612	0.608	0.605	0.603	0.600	0.598	0.595	0.593	0.591
1.2	0.641	0.628	0.620	0.615	0.610	0.606	0.604	0.602	0.600	0.598	0.596	0.594	0.592
1.4	0.638	0.625	0.618	0.613	0.609	0.605	0.603	0.601	0.600	0.599	0.596	0.594	0.593
1.6	0.636	0.624	0.617	0.612	0.608	0.605	0.602	0.601	0.600	0.599	0.597	0.595	0.594
1.8	0.634	0.622	0.615	0.611	0.607	0.604	0.602	0.601	0.599	0.599	0.597	0.595	0.595
2.0	0.632	0.621	0.614	0.610	0.607	0.604	0.601	0.600	0.599	0.599	0.597	0.596	0.595
2.5	0.629	0.619	0.612	0.608	0.605	0.603	0.601	0.600	0.599	0.599	0.598	0.597	0.596
3.0	0.627	0.617	0.611	0.606	0.604	0.603	0.601	0.600	0.599	0.599	0.598	0.597	0.597
3.5	0.625	0.616	0.610	0.606	0.604	0.602	0.601	0.600	0.599	0.599	0.598	0.597	0.596
4.0	0.623	0.614	0.609	0.605	0.603	0.602	0.600	0.599	0.599	0.598	0.597	0.597	0.596
5.0	0.621	0.613	0.608	0.605	0.603	0.601	0.599	0.599	0.598	0.598	0.597	0.596	0.596
6.0	0.618	0.611	0.607	0.604	0.602	0.600	0.599	0.599	0.598	0.598	0.597	0.596	0.596
7.0	0.616	0.609	0.606	0.603	0.601	0.600	0.599	0.599	0.598	0.958	0.597	0.596	0.596
8.0	0.614	0.608	0.605	0.603	0.601	0.600	0.599	0.598	0.598	0.597	0.596	0.596	0.596
9.0	0.613	0.607	0.604	0.602	0.600	0.599	0.599	0.598	0.597	0.597	0.596	0.596	0.595
10.0	0.611	0.606	0.603	0.601	0.599	0.598	0.598	0.597	0.597	0.597	0.596	0.596	0.595
20.0	0.601	0.600	0.599	0.598	0.597	0.596	0.596	0.596	0.596	0.596	0.596	0.595	0.594
50.0	0.596	0.596	0.595	0.595	0.594	0.594	0.594	0.594	0.594	0.594	0.594	0.593	0.593
100.0	0.593	0.593	0.592	0.592	0.592	0.592	0.592	0.592	0.592	0.592	0.592	0.592	0.592

<sup>1</sup> From Hamilton Smith's Hydraulics.

TABLE 10.—EFFLUX COEFFICIENTS FOR SQUARE ORIFICE

Values of efflux coefficient  $K$  in Eq. (25), Art. 8,  $Q = 2/3 K b \sqrt{2g(H^{3/2} - h^{3/2})}$ , for square, vertical orifices, with sharp edges, full contraction, and free discharge in air.  
For heads over 100 ft., use  $K = 0.598$

Head on center of orifice in feet	Side of square in feet												
	0.02	0.03	0.04	0.50	0.07	0.10	0.12	0.15	0.20	0.40	0.60	0.80	1.0
0.3	.....	.....	.....	0.642	0.632	0.624	0.617	0.612	.....	.....	.....	.....	.....
0.4	.....	.....	0.643	0.637	0.628	0.621	0.616	0.611	.....	.....	.....	.....	.....
0.5	.....	0.648	0.639	0.633	0.625	0.619	0.614	0.610	0.605	0.601	0.597	.....	.....
0.6	0.660	0.645	0.636	0.630	0.623	0.617	0.613	0.610	0.605	0.601	0.598	0.596	.....
0.7	0.656	0.642	0.633	.....	0.628	0.621	0.616	0.612	0.609	0.605	0.602	0.599	0.598
0.8	0.652	0.639	0.631	0.625	0.620	0.615	0.611	0.608	0.605	0.602	0.600	0.598	0.597
0.9	0.650	0.637	0.629	0.623	0.619	0.614	0.610	0.608	0.605	0.603	0.601	0.599	0.598
1.0	0.648	0.636	0.628	0.622	0.618	0.613	0.610	0.608	0.605	0.603	0.601	0.600	0.599
1.2	0.644	0.623	0.625	0.620	0.616	0.611	0.609	0.607	0.605	0.604	0.602	0.601	0.600
1.4	0.642	0.630	0.623	0.618	0.614	0.610	0.608	0.606	0.605	0.604	0.602	0.601	0.601
1.6	0.640	0.628	0.621	0.617	0.613	0.609	0.607	0.606	0.605	0.605	0.603	0.602	0.601
1.8	0.638	0.627	0.620	0.616	0.612	0.609	0.607	0.606	0.605	0.605	0.603	0.602	0.602
2.0	0.637	0.626	0.619	0.615	0.612	0.608	0.606	0.606	0.605	0.605	0.604	0.602	0.602
2.5	0.634	0.624	0.617	0.613	0.610	0.607	0.606	0.606	0.605	0.605	0.604	0.603	0.602
3.0	0.632	0.622	0.616	0.612	0.609	0.607	0.606	0.606	0.605	0.605	0.604	0.603	0.603
3.5	0.630	0.621	0.615	0.611	0.609	0.607	0.606	0.605	0.605	0.605	0.604	0.603	0.602
4.0	0.628	0.619	0.614	0.610	0.608	0.606	0.606	0.605	0.605	0.605	0.603	0.603	0.602
5.0	0.626	0.617	0.613	0.610	0.607	0.606	0.605	0.605	0.604	0.604	0.603	0.602	0.602
6.0	0.623	0.616	0.612	0.609	0.607	0.605	0.605	0.605	0.604	0.604	0.603	0.602	0.602
7.0	0.621	0.615	0.611	0.608	0.607	0.605	0.605	0.604	0.604	0.604	0.603	0.602	0.602
8.0	0.619	0.613	0.610	0.608	0.606	0.605	0.604	0.604	0.604	0.603	0.603	0.602	0.602
9.0	0.618	0.612	0.609	0.607	0.606	0.604	0.604	0.604	0.603	0.603	0.602	0.602	0.601
10.0	0.616	0.611	0.608	0.606	0.605	0.604	0.604	0.603	0.603	0.603	0.602	0.602	0.601
20.0	0.606	0.605	0.604	0.603	0.602	0.602	0.602	0.602	0.602	0.601	0.601	0.601	0.600
50.0	0.602	0.601	0.601	0.601	0.601	0.600	0.600	0.600	0.600	0.600	0.599	0.599	0.599
100.0	0.599	0.598	0.598	0.598	0.598	0.598	0.598	0.598	0.598	0.598	0.598	0.598	0.598

<sup>1</sup> From Hamilton Smith's Hydraulics.



TABLE 11.—FIRE STREAMS

From Tables Published by John R. Freeman

3/4-in. Smooth Nozzle													
Pressure at nozzle in pounds per sq. in.	Discharge in gallons per min.	Height of effective fire stream	Horizontal distance of stream	Pressure in pounds per sq. in. required at hydrant or pump to maintain pressure at nozzle through various lengths of 2-1/2-in. smooth, rubber-lined hose.									
				50	100	200	300	400	500	600	800	1000	
				ft.	ft.	ft.	ft.	ft.	ft.	ft.	ft.	ft.	
35	97	55	41	37	38	40	42	44	46	48	53	57	
40	104	60	44	42	43	46	48	50	53	55	60	65	
45	110	64	47	47	48	51	54	57	59	62	68	73	
50	116	67	50	52	54	57	60	63	66	69	75	81	
55	122	70	52	58	59	63	66	69	73	76	83	89	
60	127	72	54	63	65	68	72	76	79	83	90	97	
65	132	74	56	68	70	74	78	82	86	90	98	106	
70	137	76	58	73	75	80	84	88	92	97	105	114	
75	142	78	60	79	81	85	90	94	99	104	113	122	
80	147	79	62	84	86	91	96	101	106	111	120	130	
85	151	80	64	89	92	97	102	107	112	117	128	138	
90	156	81	65	94	97	102	108	113	119	124	135	146	
95	160	82	66	99	102	108	114	120	125	131	143	154	
100	164	83	68	105	108	114	120	126	132	138	150	163	
7/8-in. Smooth Nozzle													
35	133	56	46	38	40	44	48	52	56	60	68	76	
40	142	62	49	43	46	50	55	59	64	68	78	87	
45	150	67	52	49	51	57	62	67	72	77	87	97	
50	159	71	55	54	57	63	69	74	80	86	97	108	
55	166	74	58	60	63	69	75	82	88	94	107	119	
60	174	77	61	65	69	75	82	89	96	103	116	130	
65	181	79	64	71	74	82	89	96	104	111	126	141	
70	188	81	66	76	80	88	96	104	112	120	136	152	
75	194	83	68	82	86	94	103	111	120	128	145	162	
80	201	85	70	87	91	101	110	119	128	137	155	173	
85	207	87	72	92	97	107	116	126	136	145	165	184	
90	213	88	74	98	103	113	123	134	144	154	174	195	
95	219	89	75	103	109	119	130	141	152	163	184	206	
100	224	90	76	109	114	126	137	148	160	171	194	216	
1-in. Smooth Nozzle													
35	174	58	51	40	44	51	57	64	71	78	92	105	
40	186	64	55	46	50	58	66	73	81	89	105	120	
45	198	69	58	52	56	65	74	83	91	100	118	135	
50	208	73	61	57	62	72	82	92	102	111	131	151	
55	218	76	64	63	69	79	90	101	112	122	144	166	
60	228	79	67	67	75	87	98	110	122	134	157	181	
65	237	82	70	75	81	94	107	119	132	145	170	196	
70	246	85	72	80	87	101	115	128	142	156	183	211	
75	255	87	74	86	94	110	123	138	152	167	196	226	
80	263	89	76	92	100	115	131	147	162	178	209	241	
85	274	91	78	98	106	123	139	156	173	189	222	...	
90	279	92	80	103	112	130	147	165	183	200	236	...	
95	287	94	82	109	118	137	156	174	193	211	249	...	
100	295	96	83	115	125	144	164	183	203	223	...	...	

## FIRE STREAMS—(Continued)

1-1/8-inch Smooth Nozzle												
Pressure at nozzle in pound per sq. in.	Discharge in gallons per min.	Height of effective fire stream	Horizontal distance of stream	Pressure in pounds per sq. in. required at hydrant or pump to maintain pressure at nozzle through various lengths of 2-1/2-in. smooth, rubber-lined hose								
				50 ft.	100 ft.	200 ft.	300 ft.	400 ft.	500 ft.	600 ft.	800 ft.	1000 ft.
35	222	59	54	43	49	60	71	82	94	105	127	149
40	238	65	59	50	56	69	81	94	107	120	145	171
45	252	70	63	56	63	77	92	106	120	135	163	192
50	266	75	66	62	70	86	102	118	134	150	181	213
55	279	80	69	68	77	95	112	130	147	165	200	235
60	291	83	72	74	84	103	122	141	160	180	218	256
65	303	86	75	81	91	112	132	153	174	195	236	...
70	314	88	77	87	98	120	143	165	187	209	254	...
75	325	90	79	93	105	129	153	177	201	224	...	...
80	336	92	81	99	112	138	163	188	214	239	...	...
85	346	94	83	106	119	146	173	200	227	254	...	...
90	356	96	85	112	126	155	183	212	241	...	...	...
95	366	98	87	118	133	163	194	224	254	...	...	...
100	376	99	89	124	140	172	204	236	...	...	...	...
1-1/4-inch Smooth Nozzle												
35	277	60	59	48	57	74	91	109	126	142	178	212
40	296	67	63	55	65	84	104	124	144	164	203	243
45	314	72	67	62	73	95	117	140	162	184	229	...
50	331	77	70	68	81	106	130	155	180	204	254	...
55	347	81	73	75	89	116	143	170	198	225	...	...
60	363	85	76	82	97	127	156	186	216	245	...	...
65	377	88	79	89	105	137	169	201	234	...	...	...
70	392	91	81	96	113	148	182	217	252	...	...	...
75	405	93	83	103	121	158	195	232	...	...	...	...
80	419	95	85	110	129	169	208	248	...	...	...	...
85	432	97	88	116	137	179	221	...	...	...	...	...
90	444	99	90	123	145	190	234	...	...	...	...	...
95	456	100	92	130	154	210	247	...	...	...	...	...
100	468	101	93	137	162	211	261	...	...	...	...	...
1-3/8-inch Smooth Nozzle												
35	340	62	62	54	67	94	120	146	172	198	250	...
40	363	69	66	62	77	107	137	166	196	226	...	...
45	385	74	70	70	87	120	154	187	221	454	...	...
50	406	79	73	78	96	134	171	208	245	...	...	...
55	426	83	76	86	106	147	188	229	270	...	...	...
60	445	87	79	93	116	160	205	250	...	...	...	...
65	463	90	82	101	125	174	222	...	...	...	...	...
70	480	92	84	109	135	187	239	...	...	...	...	...
75	497	95	86	117	145	201	256	...	...	...	...	...
80	514	97	88	124	154	214	...	...	...	...	...	...
85	529	99	90	132	164	227	...	...	...	...	...	...
90	545	100	92	140	173	240	...	...	...	...	...	...
95	560	101	94	148	183	254	...	...	...	...	...	...
100	574	103	96	156	193	...	...	...	...	...	...	...

TABLE 12.<sup>1</sup>—COEFFICIENTS OF PIPE FRICTION

Values of the friction coefficient, *f*, in the formula

$$h = f \frac{l}{d} \frac{v^2}{2g}$$

Computed from the exponential formulas of Thrupp, Tutton and Unwin

Material	Diameter in inches	Velocity of flow in feet per second				
		2	4	6	8	10
Lead pipe	1	0.032	0.026	0.024	0.022	0.021
	2	0.030	0.025	0.023	0.021	0.020
	3	0.029	0.024	0.022	0.020	0.019
	4	0.028	0.023	0.021	0.020	0.019
Wood pipe	6	0.034	0.033	0.032	0.032	.....
	12	0.027	0.027	0.026	0.026	.....
	18	0.024	0.024	0.023	0.023	.....
	24	0.022	0.022	0.021	0.021	.....
	36	0.020	0.019	0.019	0.019	.....
	48	0.018	0.018	0.017	0.017	.....
Asphalted pipe	6	0.026	0.023	0.022	0.021	0.020
	12	0.025	0.022	0.021	0.020	0.019
	18	0.024	0.021	0.020	0.019	0.019
	24	0.023	0.020	0.019	0.018	0.018
	36	0.022	0.020	0.018	0.017	0.017
	48	0.021	0.019	0.017	0.017	0.016
Bare wrought iron pipe	3	0.024	0.021	0.019	0.018	0.017
	6	0.022	0.019	0.017	0.016	0.016
	12	0.019	0.017	0.015	0.014	0.014
	24	0.017	0.015	0.014	0.013	0.012
	36	0.016	0.014	0.013	0.012	0.011
	60	0.015	0.013	0.012	0.011	0.011
Riveted wrought iron or steel pipe	12	0.025	0.022	0.021	0.020	0.019
	24	0.020	0.018	0.017	0.016	0.016
	36	0.017	0.016	0.015	0.014	0.014
	48	0.016	0.014	0.014	0.013	0.013
	60	0.015	0.013	0.013	0.012	0.012
	72	0.014	0.013	0.012	0.011	0.011
New cast-iron pipe	3	0.028	0.026	0.025	0.025	.....
	6	0.024	0.022	0.022	0.021	.....
	9	0.021	0.020	0.020	0.019	.....
	12	0.020	0.019	0.018	0.018	.....
	18	0.018	0.017	0.017	0.016	.....
	24	0.017	0.016	0.016	0.015	.....
Old cast iron pipe	3	0.059	0.058	0.058	0.058	.....
	6	0.050	0.050	0.050	0.049	.....
	9	0.046	0.045	0.045	0.044	.....
	12	0.043	0.042	0.042	0.042	.....
	18	0.039	0.039	0.038	0.038	.....
	24	0.037	0.036	0.036	0.036	.....
36	0.033	0.033	0.033	0.032	.....	

<sup>1</sup> Compiled from data in Gibson's Hydraulics

TABLE 13.—FRICTION HEAD IN PIPES

Friction head in feet for each 100 ft. of straight, clean, cast-iron pipe. For old pipes the tabular values of the friction head should be doubled. Computed from Williams and Hazen's formula,  $v = C r^{0.638} s^{0.54} 0.001^{-0.04}$ ;  $v$  = velocity in feet per sec.,  $s$  = slope;  $r$  = hydraulic radius in feet,  $C = 100$ .

Discharge in gallons per min.	Inside diameter of pipe									
	1/2 in.		3/4 in.		1 in.		1-1/2 in.		2 in.	
	Velocity in feet per sec.	Friction head in feet per 100 ft.	Velocity in ft. per sec.	Friction head in feet per 100 ft.	Velocity in feet per sec.	Friction head in feet per 100 ft.	Velocity in feet per sec.	Friction head in feet per 100 ft.	Velocity in feet per sec.	Friction head in feet per 100 ft.
1	1.05	2.1	.....	.....	.....	.....	.....	.....	.....	.....
2	2.10	7.4	1.20	1.9	.....	.....	.....	.....	.....	.....
3	3.16	15.8	1.80	4.1	1.12	1.26	.....	.....	.....	.....
4	4.21	27.0	2.41	7.0	1.49	2.14	0.63	0.26	.....	.....
5	5.26	41.0	3.01	10.5	1.86	3.25	0.79	0.40	.....	.....
6	6.31	57.0	3.61	14.7	2.23	4.55	0.94	0.56	0.61	0.20
8	8.42	98.0	4.81	25.0	2.98	7.8	1.26	0.95	0.82	0.33
10	10.52	147.0	6.02	38.0	3.72	11.7	1.57	1.43	1.02	0.50
12	.....	.....	7.22	53.0	4.46	16.4	1.89	2.01	1.23	0.70
15	.....	.....	9.02	80.0	5.57	25.0	2.36	3.05	1.53	1.07
20	.....	.....	12.03	136.0	7.44	42.0	3.15	5.2	2.04	1.82
25	.....	.....	.....	.....	9.30	64.0	3.93	7.8	2.55	2.73
30	.....	.....	.....	.....	11.15	89.0	4.72	11.0	3.06	3.84
35	.....	.....	.....	.....	13.02	119.0	5.51	14.7	3.57	5.1
40	.....	.....	.....	.....	14.88	152.0	6.30	18.8	4.08	6.6
50	.....	.....	.....	.....	.....	.....	7.87	28.4	5.11	9.9
60	.....	.....	.....	.....	.....	.....	9.44	39.6	6.13	13.9
70	.....	.....	.....	.....	.....	.....	11.02	53.0	7.15	18.4
80	.....	.....	.....	.....	.....	.....	12.59	68.0	8.17	23.7
90	.....	.....	.....	.....	.....	.....	14.17	84.0	9.19	29.4
100	.....	.....	.....	.....	.....	.....	15.74	102.0	10.21	35.8
120	.....	.....	.....	.....	.....	.....	18.89	143.0	12.25	50.0
140	.....	.....	.....	.....	.....	.....	22.04	190.0	14.30	67.0
160	.....	.....	.....	.....	.....	.....	.....	.....	16.34	86.0
180	.....	.....	.....	.....	.....	.....	.....	.....	18.38	107.0
200	.....	.....	.....	.....	.....	.....	.....	.....	20.42	129.0
250	.....	.....	.....	.....	.....	.....	.....	.....	25.53	196.0

FRICTION HEAD IN PIPES—(Continued)

Discharge in gallons per min.	Inside diameter of pipe									
	2-1/2 in.		3 in.		4 in.		5 in.		6 in.	
	Velocity in feet per sec.	Friction head in feet per 100 ft.	Velocity in feet per sec.	Friction head in feet per 100 ft.	Velocity in feet per sec.	Friction head in feet per 100 ft.	Velocity in feet per sec.	Friction head in feet per 100 ft.	Velocity in feet per sec.	Friction head in feet per 100 ft.
10	0.65	0.17	0.45	0.07	.....	.....	.....	.....	.....	.....
15	0.98	0.37	0.68	0.15	.....	.....	.....	.....	.....	.....
20	1.31	0.61	0.91	0.25	0.51	0.06	.....	.....	.....	.....
25	1.63	0.92	1.13	0.38	0.64	0.09	.....	.....	.....	.....
30	1.96	1.29	1.36	0.54	0.77	0.13	0.49	0.04	.....	.....
35	2.29	1.72	1.59	0.71	0.89	0.17	0.57	0.06	.....	.....
40	2.61	2.20	1.82	0.91	1.02	0.22	0.65	0.08	0.45	0.03
50	3.27	3.32	2.27	1.38	1.28	0.34	0.82	0.11	0.57	0.05
60	3.92	4.65	2.72	1.92	1.53	0.47	0.98	0.16	0.68	0.07
70	4.58	6.2	3.18	2.57	1.79	0.63	1.14	0.21	0.79	0.09
80	5.23	7.9	3.63	3.28	2.04	0.81	1.31	0.27	0.91	0.11
90	5.88	9.8	4.09	4.08	2.30	1.0	1.47	0.34	1.02	0.14
100	6.54	12.0	4.54	4.96	2.55	1.22	1.63	0.41	1.13	0.17
120	7.84	16.8	5.45	7.0	3.06	1.71	1.96	0.58	1.36	0.24
140	9.15	22.3	6.35	9.2	3.57	2.28	2.29	0.76	1.58	0.31
160	10.46	29.0	7.26	11.8	4.08	2.91	2.61	0.98	1.82	0.41
180	11.76	35.7	8.17	14.8	4.60	3.61	2.94	1.22	2.05	0.53
200	13.07	43.1	9.08	17.8	5.11	4.4	3.27	1.48	2.27	0.61
250	16.34	65.5	11.35	27.1	6.38	6.7	4.08	2.24	2.84	0.93
300	19.61	92.0	13.62	38.0	7.66	9.3	4.90	3.14	3.40	1.29
350	22.87	122.0	15.89	50.5	8.93	12.4	5.72	4.19	3.98	1.73
400	26.14	156.0	18.16	65.0	10.21	16.0	6.54	5.4	4.54	2.21
450	29.41	196.0	20.43	81.0	11.49	19.8	7.35	6.7	5.11	2.75
500	.....	.....	22.70	98.0	12.77	24.0	8.17	8.1	5.68	3.35
550	.....	.....	24.96	117.0	14.04	28.7	8.99	9.6	6.24	3.98
600	.....	.....	27.23	137.0	15.32	33.7	9.80	11.3	6.81	4.68
700	.....	.....	.....	.....	17.87	44.9	11.44	15.1	7.95	6.24
800	.....	.....	.....	.....	20.42	57.0	13.07	19.4	9.08	7.98
900	.....	.....	.....	.....	22.98	71.0	14.71	24.0	10.22	9.93
1000	.....	.....	.....	.....	.....	.....	16.34	29.2	11.35	12.04
1100	.....	.....	.....	.....	.....	.....	17.97	34.9	12.49	14.4
1200	.....	.....	.....	.....	.....	.....	19.61	40.9	13.62	16.9
1300	.....	.....	.....	.....	.....	.....	.....	.....	14.76	19.6
1400	.....	.....	.....	.....	.....	.....	.....	.....	15.89	22.5
1500	.....	.....	.....	.....	.....	.....	.....	.....	17.03	25.6

## FRICTION HEAD IN PIPES—(Continued)

Discharge in thousands of gallons per 24 hours	Discharge in cubic feet per sec.	Inside diameter of pipe									
		8 in.		10 in.		12 in.		16 in.		20 in.	
		Velocity in feet per sec.	Friction head in feet per 100 ft.	Velocity in feet per sec.	Friction head in feet per 100 ft.	Velocity in feet per sec.	Friction head in feet per 100 ft.	Velocity in feet per sec.	Friction head in feet per 100 ft.	Velocity in feet per sec.	Friction head in feet per 100 ft.
200	0.309	0.89	0.08	0.57	0.04	0.39	0.01	0.22	0.003	.....	.....
250	0.386	1.11	0.12	0.71	0.05	0.49	0.02	0.28	0.004	.....	.....
300	0.464	1.33	0.14	0.85	0.06	0.59	0.02	0.33	0.006	.....	.....
350	0.541	1.56	0.22	0.99	0.07	0.69	0.03	0.39	0.008	.....	.....
400	0.619	1.77	0.28	1.13	0.09	0.79	0.04	0.44	0.010	0.28	0.003
450	0.696	1.99	0.34	1.28	0.12	0.89	0.05	0.50	0.012	0.31	0.004
500	0.774	2.22	0.42	1.42	0.14	0.99	0.06	0.55	0.015	0.35	0.005
550	0.851	2.44	0.50	1.56	0.17	1.09	0.07	0.61	0.017	0.39	0.006
600	0.928	2.66	0.59	1.70	0.20	1.18	0.08	0.66	0.02	0.43	0.007
700	1.083	3.10	0.78	1.99	0.26	1.38	0.11	0.77	0.03	0.50	0.009
800	1.238	3.55	0.99	2.27	0.34	1.58	0.14	0.89	0.03	0.57	0.012
900	1.392	3.99	1.24	2.55	0.42	1.77	0.17	1.00	0.04	0.64	0.014
1,000	1.547	4.43	1.51	2.84	0.51	1.97	0.21	1.11	0.05	0.71	0.017
1,100	1.702	4.88	1.80	3.12	0.61	2.17	0.25	1.22	0.06	0.78	0.020
1,200	1.857	5.37	2.11	3.40	0.71	2.36	0.29	1.33	0.07	0.85	0.024
1,500	2.321	6.65	3.18	4.26	1.08	2.96	0.44	1.66	0.11	1.06	0.04
2,000	3.094	8.86	5.4	5.67	1.84	3.94	0.76	2.22	0.19	1.42	0.06
2,500	3.868	11.08	8.4	7.10	2.78	4.92	1.15	2.77	0.28	1.77	0.09
3,000	4.642	13.30	11.6	8.51	3.86	5.91	1.60	3.32	0.40	2.13	0.13
3,500	5.41	.....	.....	9.93	5.19	6.89	2.13	3.88	0.53	2.48	0.18
4,000	6.19	.....	.....	11.35	6.65	7.88	2.70	4.43	0.68	2.84	0.23
5,000	7.74	.....	.....	14.19	10.05	9.85	4.10	5.54	1.02	3.55	0.34
6,000	9.28	.....	.....	17.03	14.09	11.82	5.8	6.65	1.43	4.26	0.48
7,000	10.83	.....	.....	.....	.....	13.79	7.7	7.76	1.90	4.96	0.64
8,000	12.38	.....	.....	.....	.....	15.76	9.9	8.86	2.42	5.67	0.82
9,000	13.92	.....	.....	.....	.....	17.73	12.2	9.97	3.02	6.38	1.02
10,000	15.47	.....	.....	.....	.....	19.70	15.0	11.08	3.68	7.09	1.24
11,000	17.02	.....	.....	.....	.....	.....	.....	12.19	4.40	7.80	1.48
12,000	18.57	.....	.....	.....	.....	.....	.....	13.30	5.2	8.51	1.74
15,000	23.21	.....	.....	.....	.....	.....	.....	16.62	7.8	10.64	2.62
16,000	24.76	.....	.....	.....	.....	.....	.....	.....	.....	11.35	2.96
17,000	26.30	.....	.....	.....	.....	.....	.....	.....	.....	12.06	3.31
18,000	27.85	.....	.....	.....	.....	.....	.....	.....	.....	12.77	3.68
19,000	29.40	.....	.....	.....	.....	.....	.....	.....	.....	13.47	4.07
20,000	30.94	.....	.....	.....	.....	.....	.....	.....	.....	14.18	4.48

FRICTION HEAD IN PIPES—(Continued)

Discharge in millions of gallons per 24 hours	Discharge in cubic feet per sec.	Inside diameter of pipe									
		24 in.		30 in.		36 in.		42 in.		48 in.	
		Velocity in feet per sec.	Friction head in feet per 100 ft.	Velocity in feet per sec.	Friction head in feet per 100 ft.	Velocity in feet per sec.	Friction head in feet per 100 ft.	Velocity in feet per sec.	Friction head in feet per 100 ft.	Velocity in feet per sec.	Friction head in feet per 100 ft.
1.0	1.547	0.49	0.007	0.32	0.002	0.22	0.002	.....	.....	.....	.....
1.5	2.321	0.74	0.015	0.47	0.005	0.33	0.003	.....	.....	.....	.....
2.0	3.094	0.98	0.026	0.63	0.009	0.44	0.004	.....	.....	.....	.....
2.5	3.868	1.23	0.039	0.79	0.013	0.55	0.005	.....	.....	.....	.....
3.0	4.642	1.48	0.055	0.95	0.018	0.66	0.008	0.48	0.004	.....	.....
3.5	5.41	1.72	0.07	1.10	0.025	0.77	0.010	0.56	0.005	.....	.....
4.0	6.19	1.97	0.09	1.26	0.032	0.88	0.013	0.64	0.006	0.49	0.003
4.5	6.96	2.22	0.12	1.42	0.039	0.99	.....	0.72	0.007	0.55	0.004
5.0	7.74	2.46	0.14	1.58	0.048	1.09	0.020	0.80	0.009	0.62	0.005
6.0	9.28	2.96	0.20	1.89	0.067	1.31	0.027	0.96	0.013	0.74	0.007
7.0	10.83	3.45	0.26	2.21	0.09	1.53	0.036	1.13	0.017	0.86	0.009
8.0	12.38	3.94	0.34	2.52	0.11	1.75	0.047	1.29	0.022	0.98	0.012
9.0	13.92	4.43	0.42	2.84	0.14	1.97	0.058	1.45	0.027	1.10	0.014
10.0	15.47	4.92	0.51	3.15	0.17	2.19	0.071	1.61	0.033	1.23	0.017
12.0	18.57	5.91	0.71	3.78	0.24	2.63	0.099	1.93	0.047	1.48	0.024
14.0	21.66	6.89	0.95	4.41	0.32	3.06	0.13	2.25	0.06	1.72	0.032
16.0	24.76	7.88	1.22	5.04	0.41	3.50	0.17	2.57	0.08	1.97	0.042
18.0	27.85	8.86	1.52	5.67	0.51	3.94	0.21	2.89	0.10	2.22	0.052
20.0	30.94	9.85	1.83	6.30	0.62	4.38	0.25	3.22	0.12	2.46	0.063
22.0	34.04	10.83	2.19	6.93	0.74	4.82	0.30	3.53	0.14	2.71	0.075
24.0	37.13	11.82	2.59	7.56	0.87	5.25	0.36	3.86	0.17	2.96	0.09
26.0	40.23	12.80	2.99	8.20	1.01	5.69	0.41	4.18	0.20	3.20	0.10
28.0	43.32	13.79	3.42	8.83	1.16	6.13	0.48	4.50	0.22	3.45	0.12
30.0	46.42	14.77	3.90	9.46	1.32	6.57	0.54	4.82	0.26	3.69	0.13
32.0	49.51	.....	.....	10.09	1.48	7.00	0.61	5.15	0.29	3.94	0.15
34.0	52.6	.....	.....	10.72	1.66	7.44	0.68	5.47	0.32	4.19	0.17
36.0	55.7	.....	.....	11.35	1.84	7.88	0.76	5.79	0.36	4.43	0.19
38.0	58.8	.....	.....	11.98	2.04	8.32	0.84	6.11	0.40	4.68	0.21
40.0	61.9	.....	.....	.....	.....	8.76	0.92	6.45	0.44	4.92	0.23
50.0	77.4	.....	.....	.....	.....	10.95	1.39	8.04	0.66	6.16	0.34
60.0	92.8	.....	.....	.....	.....	13.13	1.96	9.65	0.92	7.39	0.48
70.0	108.3	.....	.....	.....	.....	.....	.....	11.26	1.22	8.62	0.64
80.0	123.8	.....	.....	.....	.....	.....	.....	12.86	1.57	9.85	0.82
90.0	139.2	.....	.....	.....	.....	.....	.....	.....	.....	11.08	1.02
100.0	154.7	.....	.....	.....	.....	.....	.....	.....	.....	12.31	1.24

TABLE 14.—BAZIN'S VALUES OF CHEZY'S COEFFICIENT

Values of the coefficient  $C$  in Chezy's formula  $v = C\sqrt{rs}$  according to Bazin's formula (Art. 24):

$$C = \frac{87}{0.552 + \frac{m}{\sqrt{r}}}$$

Hydraulic radius $r$ , in feet	Coefficient of roughness, $m$					
	Planed tim- ber or smooth cement	Unplaned timber, well laid brick, or concrete	Ashlar, good rubble mas- onry, or poor brick- work	Earth in good condition	Earth in ordinary condition	Earth in bad condition
	$m = 0.06$	$m = 0.16$	$m = 0.46$	$m = 0.85$	$m = 1.30$	$m = 1.75$
0.1	117	82	43	27	19	14
0.2	127	96	55	35	25	19
0.3	131	103	63	41	30	23
0.4	135	108	68	46	33	26
0.5	136	112	71	50	36	29
0.6	138	115	76	53	39	31
0.7	139	117	79	55	41	33
0.8	141	119	82	58	43	35
0.9	141	121	84	60	45	36
1.0	142	122	86	62	47	38
1.25	143	125	90	66	51	41
1.50	145	127	94	70	54	44
1.75	145	129	97	73	57	47
2.00	146	131	99	75	59	49
2.5	147	133	104	80	63	53
3.0	148	135	106	83	67	57
4.0	150	138	111	89	72	61
5.0	150	140	115	93	77	65
6.0	151	141	118	97	80	69
7.0	152	142	120	100	83	72
8.0	152	143	122	102	86	74
9.0	152	144	123	104	88	77
10.0	152	145	125	106	90	79
12.0	153	145	127	109	94	82
15.0	153	147	130	113	98	86
20.0	154	148	133	117	103	92
30.0	155	150	137	123	110	100
40.0	155	151	139	127	115	105
50.0	155	151	141	129	118	109



TABLE 15.—KUTTER'S VALUES OF CHEZY'S COEFFICIENT

Values of the coefficient  $C$  in Chezy's formula  $v = C\sqrt{rs}$  according to Kutter's formula (Eq. (67), Art. 24):

$$C = \frac{41.65 + \frac{0.00281}{s} + \frac{1.811}{n}}{1 + (41.65 + \frac{0.00281}{s}) \frac{n}{\sqrt{r}}}$$

Slope, $s$	Coefficient of roughness, $n$	Hydraulic radius $r$ , in feet															
		0.1	0.2	0.4	0.6	0.8	1	1.5	2	3	4	6	8	10	15	20	
$s = 0.000025$ = 1 in 40,000 = 0.132 ft. per mile	0.009	65	87	111	127	138	148	166	179	197	209	226	238	246	262	271	
	0.010	57	75	97	112	122	131	148	160	177	188	206	216	225	240	249	
	0.011	50	67	87	100	109	118	133	144	160	172	188	199	207	222	231	
	0.012	44	59	78	90	99	106	121	131	147	158	174	184	192	206	215	
	0.013	40	53	70	81	90	97	111	121	135	146	161	171	179	193	202	
	0.017	28	38	51	60	66	72	83	91	103	113	126	135	142	155	164	
	0.020	23	31	42	49	55	60	69	77	88	96	108	117	124	136	144	
	0.025	17	24	32	38	43	47	55	61	70	78	88	96	102	114	121	
	0.030	14	19	26	31	35	38	45	50	59	65	74	82	87	98	106	
	0.035	12	16	22	26	30	32	38	43	50	56	64	71	76	86	94	
$s = 0.00005$ = 1 in 20,000 = 0.264 ft. per mile	0.009	78	100	124	139	150	158	173	184	198	207	220	228	234	244	250	
	0.010	67	87	109	122	133	140	154	164	178	187	199	206	212	220	228	
	0.011	59	77	97	109	119	126	139	148	161	170	182	189	195	205	211	
	0.012	52	68	88	98	107	114	126	135	148	156	168	175	181	189	196	
	0.013	47	62	79	90	98	104	116	124	136	145	156	163	169	179	184	
	0.017	33	44	57	65	71	77	87	94	104	111	122	129	134	142	149	
	0.020	26	35	46	53	59	64	72	79	88	95	105	111	116	125	131	
	0.025	20	26	35	41	46	49	57	62	71	77	85	91	96	104	110	
	0.030	16	21	28	33	37	40	47	51	59	64	72	78	82	90	96	
	0.035	13	18	24	28	31	34	40	44	50	56	63	68	72	79	85	
$s = 0.0001$ = 1 in 10,000 = 0.528 ft. per mile	0.009	90	112	136	149	158	166	178	187	198	206	215	221	226	233	237	
	0.010	78	98	119	131	140	147	159	168	178	186	195	201	205	212	216	
	0.011	68	86	106	118	126	132	144	151	162	169	178	184	188	195	200	
	0.012	60	76	95	105	114	120	130	138	149	155	164	170	174	181	185	
	0.013	54	69	86	96	103	109	120	127	137	143	152	158	162	169	173	
	0.017	37	48	62	70	76	81	89	96	104	111	119	124	128	135	139	
	0.020	30	39	50	57	63	67	75	81	89	94	102	107	111	118	122	
	0.025	22	29	38	44	48	52	59	64	71	76	84	88	92	98	102	
	0.030	17	23	31	35	39	42	48	53	59	64	71	75	78	85	89	
	0.035	14	19	25	30	33	35	41	45	51	55	61	66	69	75	79	

KUTTER'S VALUE OF CHEZY'S COEFFICIENT—(Continued)

Slope, <i>s</i>	Coefficient of roughness, <i>n</i>	Hydraulic radius <i>r</i> in feet															
		0.1	0.2	0.3	0.4	0.6	0.8	1.0	1.5	2	3	4	6	10	15	20	
<i>s</i> = 0.0002 = 1 in. 5000 = 1.056 ft. per mile	0.009	99	121	133	143	155	164	170	181	188	200	205	213	222	228	231	
	0.010	85	105	116	125	138	145	151	162	170	179	185	193	201	207	210	
	0.011	74	93	103	112	122	131	136	146	154	163	168	176	185	190	194	
	0.012	65	83	92	100	111	118	123	133	140	149	155	162	170	176	180	
	0.013	59	74	83	91	100	107	113	122	129	137	143	150	158	164	168	
	0.017	41	52	59	65	73	79	83	91	97	105	111	117	125	131	134	
	0.020	32	42	48	53	60	65	69	77	82	89	94	100	108	113	117	
	0.025	24	31	36	40	46	50	54	60	64	72	76	82	89	95	98	
	0.030	18	25	29	32	37	41	44	49	54	59	63	69	76	82	85	
	0.035	15	21	24	27	31	34	37	42	45	51	55	60	67	72	76	
<i>s</i> = 0.0004 = 1 in. 2500 = 2.112 ft. per mile	0.009	104	126	138	148	157	166	172	183	190	199	204	211	219	224	227	
	0.010	89	110	120	129	140	148	154	164	170	179	184	191	199	203	207	
	0.011	78	97	107	115	126	133	138	148	154	162	168	175	183	187	190	
	0.012	69	87	96	104	113	121	125	135	141	149	154	161	168	172	176	
	0.013	62	78	87	94	103	110	115	124	130	138	142	149	157	162	164	
	0.017	43	54	62	68	75	81	85	93	98	105	110	116	123	128	131	
	0.020	34	44	50	55	62	67	70	78	83	89	94	99	107	110	115	
	0.025	25	32	37	42	47	51	55	61	65	71	76	81	88	92	96	
	0.030	19	25	30	33	38	42	45	50	54	59	63	69	75	80	83	
	0.035	16	21	24	27	31	35	37	42	45	51	55	60	66	70	73	
<i>s</i> = 0.001 = 1 in. 1000 = 5.28 ft. per mile	0.009	110	129	141	150	161	169	175	184	191	199	204	211	218	222	225	
	0.010	94	113	124	131	142	150	155	165	171	179	184	190	197	202	205	
	0.011	83	99	109	117	127	134	139	149	155	163	168	174	181	186	188	
	0.012	73	89	98	105	115	122	127	136	142	149	154	160	167	171	175	
	0.013	65	81	89	96	104	111	116	124	130	138	142	149	155	160	163	
	0.017	45	57	63	69	76	82	86	93	98	105	110	116	122	127	129	
	0.020	36	45	51	56	63	68	71	78	83	89	93	99	105	110	113	
	0.025	27	34	39	43	48	52	56	62	66	71	75	81	87	91	94	
	0.030	21	27	30	34	39	42	45	50	54	59	63	68	74	78	81	
	0.035	17	22	25	28	32	35	38	43	46	51	54	59	65	68	72	
<i>s</i> = 0.01, = 1 in. 100 = 52.8 ft. per mile	0.009	110	130	143	151	162	170	175	185	191	199	204	210	217	222	225	
	0.010	95	114	125	133	143	151	156	165	171	179	184	190	196	200	204	
	0.011	83	100	111	119	129	135	141	149	155	162	167	173	180	184	187	
	0.012	74	90	100	107	116	123	128	136	142	149	154	160	166	170	173	
	0.013	66	81	90	98	106	112	117	125	130	138	142	148	154	159	161	
	0.017	46	57	64	70	77	82	87	94	99	105	109	115	121	126	128	
	0.020	36	46	52	57	64	68	72	79	83	89	93	99	105	108	112	
	0.025	27	34	39	44	49	53	56	62	66	71	76	81	86	90	93	
	0.030	21	27	31	35	39	43	45	51	55	59	63	68	74	77	80	
	0.035	17	22	25	29	33	35	38	43	46	51	55	59	65	68	71	

TABLE 16.—DISCHARGE COEFFICIENTS FOR RECTANGULAR NOTCH WEIRS

As determined by Hamilton Smith, Jr. (see Art. 10)

Contracted weir													Suppressed weir						
$Q = 2/3Cb\sqrt{2g}(h + 1.4H)^{3/2}$													$Q = 2/3Cb\sqrt{2g}(h + \frac{1}{3}H)^{3/2}$						
Values of coefficient <i>K</i>													Values of coefficient <i>C</i>						
Length of weir in feet													Length of weir in feet						
1	2	2.6	3	4	5	7	10	15	19	Effective head, <i>h</i> in feet	19	15	10	7	5	4	3	2	0.66
0.632	0.639	0.646	0.650	0.652	0.653	0.653	0.654	0.655	0.656	0.1	0.657	0.657	0.658	0.658	0.658	0.659	0.659	0.659	0.675
0.619	0.625	0.634	0.637	0.638	0.639	0.640	0.640	0.641	0.642	0.15	0.643	0.644	0.644	0.644	0.645	0.645	0.647	0.649	0.662
0.611	0.618	0.626	0.629	0.630	0.631	0.631	0.632	0.633	0.634	0.2	0.635	0.636	0.637	0.637	0.638	0.641	0.642	0.645	0.656
0.605	0.612	0.621	0.623	0.624	0.625	0.626	0.627	0.628	0.629	0.25	0.630	0.631	0.632	0.633	0.634	0.636	0.638	0.641	0.653
0.601	0.608	0.616	0.618	0.619	0.621	0.621	0.623	0.624	0.625	0.3	0.626	0.627	0.628	0.629	0.631	0.633	0.636	0.639	0.651
0.595	0.601	0.609	0.612	0.613	0.614	0.615	0.617	0.618	0.619	0.4	0.621	0.622	0.623	0.625	0.628	0.630	0.633	0.636	0.650
0.590	0.596	0.605	0.607	0.608	0.610	0.611	0.613	0.615	0.616	0.5	0.619	0.620	0.621	0.624	0.627	0.630	0.633	0.637	0.650
0.587	0.593	0.601	0.604	0.605	0.607	0.608	0.611	0.613	0.614	0.6	0.618	0.619	0.620	0.623	0.627	0.630	0.634	0.638	0.651
0.585	0.590	0.598	0.601	0.603	0.604	0.606	0.609	0.612	0.613	0.7	0.618	0.619	0.620	0.624	0.628	0.631	0.635	0.640	0.653
.....	.....	0.595	0.598	0.600	0.602	0.604	0.607	0.611	0.612	0.8	0.618	0.620	0.621	0.625	0.629	0.633	0.637	0.643	0.656
.....	.....	0.592	0.596	0.598	0.600	0.603	0.606	0.609	0.611	0.9	0.619	0.620	0.622	0.627	0.631	0.635	0.639	0.645	.....
.....	.....	0.590	0.593	0.595	0.598	0.601	0.604	0.608	0.610	1.0	0.619	0.621	0.624	0.628	0.633	0.637	0.641	0.648	.....
.....	.....	0.587	0.591	0.593	0.596	0.599	0.603	0.606	0.609	1.1	0.620	0.622	0.625	0.630	0.635	0.639	0.644	.....	.....
.....	.....	0.585	0.589	0.591	0.594	0.597	0.601	0.605	0.608	1.2	0.620	0.623	0.626	0.632	0.636	0.641	0.646	.....	.....
.....	.....	0.582	0.586	0.589	0.592	0.596	0.599	0.604	0.607	1.3	0.621	0.624	0.628	0.633	0.638	0.643	0.648	.....	.....
.....	.....	0.580	0.584	0.587	0.590	0.594	0.598	0.602	0.606	1.4	0.622	0.625	0.629	0.634	0.640	0.644	.....	.....	.....
.....	.....	0.582	0.585	0.589	0.592	0.596	0.599	0.605	0.608	1.5	0.622	0.625	0.630	0.636	0.641	0.646	.....	.....	.....
.....	.....	0.580	0.583	0.587	0.591	0.595	0.600	0.604	0.607	1.6	0.623	0.626	0.631	0.637	0.642	0.647	.....	.....	.....
.....	.....	.....	.....	.....	.....	0.594	0.599	0.603	0.607	1.7	0.623	0.626	0.632	0.638	.....	.....	.....	.....	.....

TABLE 17.—DISCHARGE PER INCH OF LENGTH OVER RECTANGULAR NOTCH WEIRS

Discharge over sharp-crested, vertical, rectangular notch weirs in cubic feet per minute per inch of length.

Computed from Eq. (30), Art. 10:  $Q = 0.4 bh^{3/2}$  for  $b = 1$  in.

Depth on crest in inches	0	1/8	1/4	3/8	1/2	5/8	3/4	7/8
0	0.00	0.01	0.05	0.09	0.14	0.19	0.26	0.32
1	0.40	0.47	0.55	0.64	0.73	0.82	0.92	1.02
2	1.13	1.23	1.35	1.46	1.58	1.70	1.82	1.95
3	2.07	2.21	2.34	2.48	2.61	2.76	2.90	3.05
4	3.20	3.35	3.50	3.66	3.81	3.97	4.14	4.30
5	4.47	4.64	4.81	4.98	5.15	5.33	5.51	5.69
6	5.87	6.06	6.25	6.44	6.62	6.82	7.01	7.21
7	7.40	7.60	7.80	8.01	8.21	8.42	8.63	8.83
8	9.05	9.26	9.47	9.69	9.91	10.13	10.35	10.57
9	10.80	11.02	11.25	11.48	11.71	11.94	12.17	12.41
10	12.64	12.88	13.12	13.36	13.60	13.85	14.09	14.34
11	14.59	14.84	15.09	15.34	15.59	15.85	16.11	16.36
12	16.62	16.88	17.15	17.41	17.67	17.94	18.21	18.47
13	18.74	19.01	19.29	19.56	19.84	20.11	20.39	20.67
14	20.95	21.23	21.51	21.80	22.08	22.37	22.65	22.94
15	23.23	23.52	23.82	24.11	24.40	24.70	25.00	25.30
16	25.60	25.90	26.20	26.50	26.80	27.11	27.42	27.72
17	28.03	28.34	28.65	28.97	29.28	29.59	29.91	30.22
18	30.54	30.86	31.18	31.50	31.82	32.15	32.47	32.80
19	33.12	33.45	33.78	34.11	34.44	34.77	35.10	35.44
20	35.77	36.11	36.45	36.78	37.12	37.46	37.80	38.15
21	38.49	38.84	39.18	39.53	39.87	40.24	40.60	40.96
22	41.28	41.64	41.98	42.36	42.68	43.04	43.44	43.76
23	44.12	44.48	44.84	45.20	45.56	45.96	46.32	46.68
24	47.04	47.40	47.76	48.12	48.52	48.88	49.28	49.64
25	50.00	50.40	50.76	51.08	51.52	51.88	52.28	52.64
26	53.04	53.40	53.80	54.16	54.56	54.96	55.36	55.72
27	56.12	56.52	56.92	57.32	57.68	58.08	58.48	58.88
28	59.28	59.68	60.08	60.48	60.84	61.28	61.68	62.08
29	62.48	62.88	63.28	63.68	64.08	64.52	64.92	65.32
30	65.72	66.16	66.56	66.96	67.36	67.80	68.20	68.64

TABLE 18.—DISCHARGE PER FOOT OF LENGTH OVER RECTANGULAR NOTCH WEIRS

Discharge over sharp crested, vertical, rectangular notch weirs in cubic feet per second per foot of length. Computed from Eq. (29), Art. 10:

$$Q = 3.36bh^{3/2} \text{ for } b = 1 \text{ ft.}$$

Depth on crest in feet	0.00	0.01	0.02	0.03	0.04	0.05	0.06	0.07	0.08	0.09
0.0	0.000	0.003	0.009	0.017	0.026	0.037	0.049	0.061	0.075	0.089
0.1	0.104	0.120	0.137	0.155	0.173	0.192	0.211	0.231	0.252	0.273
0.2	0.295	0.317	0.341	0.364	0.388	0.413	0.438	0.463	0.489	0.515
0.3	0.542	0.570	0.597	0.626	0.654	0.683	0.713	0.743	0.773	0.804
0.4	0.835	0.866	0.898	0.931	0.963	0.996	1.030	1.063	1.098	1.132
0.5	1.167	1.202	1.238	1.273	1.309	1.346	1.383	1.420	1.458	1.496
0.6	1.538	1.572	1.611	1.650	1.690	1.729	1.769	1.810	1.850	1.892
0.7	1.933	1.974	2.016	2.058	2.101	2.143	2.187	2.230	2.273	2.317
0.8	2.361	2.406	2.450	2.495	2.541	2.586	2.632	2.678	2.724	2.768
0.9	2.818	2.865	2.912	2.960	3.008	3.055	3.104	3.152	3.202	3.251
1.0	3.300	3.350	3.399	3.449	3.501	3.551	3.600	3.653	3.703	3.755
1.1	3.808	3.858	3.911	3.963	4.016	4.069	4.122	4.178	4.231	4.283
1.2	4.340	4.392	4.448	4.501	4.557	4.613	4.666	4.722	4.778	4.834
1.3	4.891	4.947	5.006	5.062	5.118	5.178	5.234	5.293	5.349	5.409
1.4	5.468	5.524	5.584	5.643	5.702	5.762	5.821	5.881	5.940	6.003
1.5	6.062	6.125	6.184	6.247	6.306	6.369	6.428	6.491	6.554	6.617
1.6	6.679	6.742	6.805	6.867	6.930	6.993	7.059	7.121	7.187	7.250
1.7	7.316	7.379	7.445	7.508	7.573	7.639	7.706	7.772	7.838	7.904
1.8	7.970	8.036	8.102	8.171	8.237	8.303	8.372	8.438	8.507	8.573
1.9	8.643	8.712	8.778	8.847	8.917	8.986	9.055	9.125	9.194	9.263
2.0	9.332	9.405	9.474	9.544	9.616	9.686	9.758	9.827	9.900	9.969
2.1	10.042	10.115	10.187	10.260	10.332	10.405	10.478	10.550	10.623	10.695
2.2	10.768	10.841	10.916	10.989	11.065	11.138	11.213	11.286	11.362	11.435
2.3	11.510	11.586	11.662	11.738	11.814	11.887	11.966	12.042	12.118	12.194
2.4	12.269	12.345	12.425	12.500	12.576	12.656	12.731	12.811	12.890	12.966
2.5	12.935	13.124	13.200	13.279	13.358	13.438	13.517	13.596	13.675	13.754
2.6	13.834	13.916	13.995	14.075	14.154	14.236	14.315	14.398	14.477	14.560
2.7	14.642	14.721	14.804	14.886	14.969	15.048	15.131	15.213	15.296	15.378
2.8	15.461	15.543	15.629	15.711	15.794	15.876	15.962	16.045	16.130	16.213
2.9	16.299	16.381	16.467	16.550	16.635	16.721	16.807	16.889	16.975	17.061
3.0	17.147	17.233	17.318	17.404	17.490	17.579	17.665	17.751	17.837	17.926
3.1	18.011	18.101	18.186	18.275	18.361	18.450	18.536	18.625	18.714	18.803
3.2	18.889	18.978	19.067	19.157	19.246	19.335	19.424	19.513	19.602	19.694
3.3	19.784	19.873	19.962	20.054	20.143	20.236	20.325	20.414	20.506	20.599
3.4	20.688	20.780	20.873	20.962	21.054	21.146	21.239	21.331	21.424	21.516
3.5	21.608	21.701	21.793	21.886	21.978	22.074	22.166	22.259	22.354	22.447
3.6	22.542	22.635	22.730	22.823	22.919	23.011	23.107	23.202	23.295	23.390
3.7	23.486	23.582	23.678	23.773	23.869	23.965	24.060	24.156	24.252	24.347
3.8	24.446	24.542	24.638	24.734	24.833	24.928	25.027	25.123	25.222	25.318
3.9	25.417	25.516	25.611	25.710	25.809	25.905	26.004	26.103	26.202	26.301
4.0	26.400	26.499	26.598	26.697	26.796	26.895	26.997	27.096	27.195	27.298

TABLE 19.—PRINCIPLES

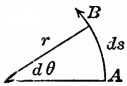
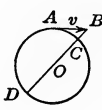
Kinematics (motion)		
	Linear motion	Angular motion
Notation	$s$ = displacement $v$ = velocity $a$ = acceleration $v_0$ = initial velocity $F$ = force $W = Fs$ = work $m$ = mass $w = mg$ = weight $t$ = time $Ft$ = impulse $mv$ = momentum	$\theta$ = displacement $\omega$ = velocity $\alpha$ = acceleration $\omega_0$ = initial velocity $M$ = torque about fixed axis $W = M\theta$ = work $I = \Sigma mr^2$ = moment of inertia $t$ = time $Mt$ = impulse $I\omega$ = momentum
Definitions	$v = \frac{ds}{dt}, a = \frac{dv}{dt} = \frac{d^2s}{dt^2}$	$\omega = \frac{d\theta}{dt}, \alpha = \frac{d\omega}{dt} = \frac{d^2\theta}{dt^2}$
Uniformly accelerated motion accel. = const.	$v = v_0 + at$ $s = v_0t + \frac{1}{2}at^2$ $v^2 = v_0^2 + 2as$	$\omega = \omega_0 + \alpha t$ $\theta = \omega_0t + \frac{1}{2}\alpha t^2$ $\omega^2 = \omega_0^2 + 2\alpha\theta$
Derivation of above formulas	$\frac{d^2s}{dt^2} = a, \frac{ds}{dt} = at + C_1$ $s = \frac{1}{2}at^2 + C_1t + C_2$ If $t = 0, v = v_0 \therefore C_1 = v_0$ If $t = 0, s = 0 \therefore C_2 = 0$	$\frac{d^2\theta}{dt^2} = \alpha, \frac{d\theta}{dt} = \alpha t + C_1$ $\theta = \frac{1}{2}\alpha t^2 + C_1t + C_2$ If $t = 0, \omega = \omega_0 \therefore C_1 = \omega_0$ If $t = 0, \theta = 0 \therefore C_2 = 0$
Relation between linear and angular motion	$v = r\omega$ $a_t = r\alpha$ $a_n = v^2/r = r\omega^2$	$a_t = \text{tang. comp. of accel.}$ $a_n = \text{normal comp. of accel.}$
Derivation of first two formulas		$\text{Arc } AB = ds = rd\theta$ $\frac{ds}{dt} = r \frac{d\theta}{dt}$ $v = r\omega$ $\frac{dv}{dt} = r \frac{d\omega}{dt}$ $a_t = r\alpha$
Derivation of normal accel. for uniform circular motion		If body at A were free, it would proceed in direction of tangent AB and in time $t$ would reach B where $AB = vt$ . Since it is found at C instead of B it must have experienced a central acceleration. Let $a_n$ denote this central acceleration. Then $BC = \frac{1}{2}a_n t^2$ . By geometry $BC \times BD = AB^2$ and in the limit $BD$ approaches $2r$ . Hence $\frac{1}{2}a_n t^2 \times 2r = v^2 t^2$ , from which $a_n = v^2/r = \omega^2 r$ .

OF MECHANICS

Dynamics (force)		
	Linear motion	Angular motion
Fundamental law	$F = ma$	$M = I\alpha$
Discussion and derivation	<p>By experiment it is found that <math>F \propto a</math> (Newton's 2nd Law)  <math>\therefore F/a = \text{const.}</math>, say <math>m</math>, whence <math>F = ma</math>. <math>m</math> = intrinsic property of body called its mass. Mass = measured inertia.</p> <p>If <math>F = 0</math> then <math>a = 0</math> and hence <math>v = 0</math> or constant, which expresses Newton's 1st Law.</p> <p><math>F</math> = impressed force, <math>ma</math> = kinetic reaction or inertia force. Equality <math>F = ma</math> is dynamical expression of Newton's 3rd Law.</p>	<p>Consider rotation of rigid body about a fixed axis.  Then for a particle of mass <math>m</math> at distance <math>r</math> from axis of rotation, law <math>F = ma</math> becomes <math>Fr = mar</math>, or since <math>a = r\alpha</math>, <math>Fr = mr^2\alpha</math>.</p> <p>By summation  <math>\Sigma Fr = \Sigma mr^2\alpha</math>  But <math>\Sigma Fr = M</math>, and <math>\Sigma mr^2 = I</math>  <math>\therefore M = I\alpha</math>.</p>
Principle of work and energy	$W = Fs = \frac{mv^2}{2} - \frac{mv_0^2}{2}$	$W = M\theta = \frac{I\omega^2}{2} - \frac{I\omega_0^2}{2}$
Derivation	<p><math>F = ma, v^2 = v_0^2 + 2as</math>  <math>\therefore as = \frac{v^2 - v_0^2}{2}</math>, and  <math>W = Fs = mas = \frac{mv^2}{2} - \frac{mv_0^2}{2}</math></p>	<p><math>M = I\alpha, \omega^2 = \omega_0^2 + 2\alpha\theta</math>  <math>\therefore \alpha\theta = \frac{\omega^2 - \omega_0^2}{2}</math>, and  <math>W = M\theta = I\alpha\theta = \frac{I\omega^2 - I\omega_0^2}{2}</math></p>
Principle of impulse and momentum	$Ft = mv - mv_0$	$Mt = I\omega - I\omega_0$
Derivation	<p><math>F = ma, v = v_0 + at</math>  <math>\therefore at = v - v_0</math>, and  <math>Ft = mat = mv - mv_0</math></p>	<p><math>M = I\alpha, \omega = \omega_0 + \alpha t</math>  <math>\therefore \alpha t = \omega - \omega_0</math>, and  <math>Mt = I\alpha t = I\omega - I\omega_0</math></p>
Power	Power = $Fv$ , h.p. = $\frac{Fv}{550}$	Power = $M\omega$ , h.p. = $\frac{M\omega}{550}$
Centrifugal force	$F_c = \frac{w}{g} a_n = \frac{w}{g} \frac{v^2}{r} = \frac{w}{g} \omega^2 r$	
Derivation	Special case of $F = ma$ where $m = \frac{w}{g}$ and $a = \frac{v^2}{r}$	
D'Alembert's principle	$F - m \frac{d^2s}{dt^2} = 0$	
Explanation and use	<p><math>F = ma</math> where <math>F</math> = external impressed force and <math>a</math> = accel. produced. Introduce another force <math>P</math>, given by <math>P = -ma</math>. Then by addition, <math>F + P = 0</math>; i.e., the body is in equilibrium under the action of <math>F</math> and <math>P</math>. <math>P</math> is called the kinetic reaction, or reversed effective force, since <math>P = -F</math>. By introducing this idea of the kinetic reactions equilibrating the impressed forces, all problems in dynamics are reduced to statical problems. This is called d'Alembert's Principle, and is usually expressed in the form</p> $F - m \frac{d^2s}{dt^2} = 0.$	

TABLE 20.<sup>1</sup>—DISCHARGE PER FOOT OF LENGTH OVER SUPPRESSED WEIRS

Discharge over sharp-crested, vertical, suppressed weirs in cubic feet per second per foot of length. Computed by Bazin's formula (Art. 10):

$$Q = \left( 0.405 + \frac{0.00984}{h} \right) \left( 1 + 0.55 \left( \frac{h}{d+h} \right)^2 \right) bh\sqrt{2gh}, \text{ for } b = 1 \text{ ft.}$$

Head on crest, <i>h</i> , in feet	Height of weir, <i>d</i> , in feet						
	2	4	6	8	10	20	30
0.1	0.13	0.13	0.13	0.13	0.13	0.13	0.13
0.2	0.33	0.33	0.33	0.33	0.33	0.33	0.33
0.3	0.58	0.58	0.58	0.58	0.58	0.58	0.58
0.4	0.88	0.88	0.87	0.87	0.87	0.87	0.87
0.5	1.23	1.21	1.21	1.21	1.21	1.20	1.20
0.6	1.62	1.59	1.58	1.58	1.57	1.57	1.57
0.7	2.04	1.99	1.98	1.98	1.97	1.97	1.97
0.8	2.50	2.43	2.41	2.41	2.40	2.40	2.40
0.9	3.00	2.90	2.88	2.86	2.86	2.85	2.85
1.0	3.53	3.40	3.36	3.35	3.34	3.33	3.33
1.1	4.09	3.92	3.87	3.86	3.85	3.84	3.84
1.2	4.68	4.48	4.42	4.40	4.38	4.36	4.36
1.3	5.31	5.07	4.99	4.96	4.94	4.91	4.91
1.4	5.99	5.68	5.58	5.54	5.52	5.49	5.48
1.5	6.68	6.30	6.20	6.16	6.13	6.10	6.09
1.6	7.40	6.97	6.84	6.78	6.74	6.69	6.69
1.7	8.14	7.66	7.49	7.42	7.39	7.33	7.32
1.8	8.93	8.37	8.18	8.09	8.05	7.98	7.96
1.9	9.75	9.11	8.89	8.79	8.74	8.65	8.63
2.0	10.58	9.87	9.62	9.51	9.44	9.34	9.32
2.1	11.45	10.65	10.37	10.25	10.17	10.05	10.02
2.2	12.34	11.46	11.14	10.99	10.91	10.78	10.75
2.3	13.24	12.29	11.93	11.77	11.66	11.52	11.48
2.4	14.20	13.15	12.75	12.56	12.45	12.28	12.24
2.5	15.17	14.03	13.59	13.38	13.26	13.06	13.01
2.6	16.16	14.92	14.44	14.20	14.07	13.85	13.80
2.7	17.18	15.83	15.31	15.04	14.92	14.65	14.60
2.8	18.23	16.79	16.21	15.92	15.76	15.48	15.42
2.9	19.29	17.77	17.11	16.79	16.63	16.33	16.25
3.0	20.39	18.74	18.06	17.71	17.52	17.18	17.10
3.1	21.50	19.74	19.02	18.64	18.42	18.04	17.96
3.2	22.64	20.77	19.98	19.58	19.34	18.93	18.83
3.3	23.81	21.80	20.98	20.55	20.27	19.82	19.73
3.4	24.98	22.89	21.99	21.52	21.24	20.75	20.63
3.5	26.20	24.00	23.01	22.48	22.22	21.69	21.60
3.6	27.41	25.09	24.06	23.52	23.20	22.62	22.48
3.7	28.64	26.22	25.14	24.56	24.20	23.59	23.43
3.8	29.94	27.38	26.22	25.60	25.23	24.56	24.39
3.9	31.21	28.53	27.33	26.65	26.26	25.53	25.34
4.0	32.54	29.74	28.45	27.74	27.32	26.55	26.35
4.1	33.85	30.95	29.59	28.83	28.36	27.55	27.33
4.2	35.22	32.18	30.75	29.96	29.48	28.59	28.36
4.3	36.59	33.43	31.93	31.10	30.58	29.62	29.37
4.4	37.99	34.70	33.12	32.24	31.70	30.66	30.42
4.5	39.40	35.98	34.33	33.39	32.83	31.74	31.47
4.6	40.83	37.29	35.56	34.58	33.98	32.84	32.53
4.7	42.29	38.62	36.82	35.75	35.13	33.93	33.61
4.8	43.75	39.96	38.07	37.00	36.33	35.05	34.70
4.9	45.22	41.30	39.35	38.20	37.49	36.15	35.77
5.0	46.71	42.67	40.62	39.44	38.70	37.28	36.88

<sup>1</sup> Compiled from extensive hydraulic tables by Williams and Hazen.



## INDEX

### A

- Accumulator, hydraulic, 9
- Adjutage, Venturi, 63
- American type of turbine, 170
- Aqua Claudia, 137
- Aqueducts, comparison of, 136
- Archimedes, theorem of, 21

### B

- Backwater, 118
- Barge canal, N. Y. State, 96
- Barker's mill, 155
- Barometer, mercury, 18
  - water, 17
- Bazin's coefficient, 280
  - formula, 102
- Bends and elbows, head lost at, 77
- Bernoulli's theorem, 64
- Borda mouthpiece, 61
- Branching pipes, 88, 133
- Breast wheel, 158
- Buoyancy, 20
  - chamber, Keokuk lock, 39

### C

- Canal lock, 58
- Capacity criterion, 184
- Catskill aqueduct, 36, 140
  - Venturi meter, 69, 70
- Center of pressure, 13
- Centrifugal pumps, 215
  - characteristics, 227
  - efficiency and design of, 234
- Channel cross section, 103
- Characteristic for centrifugal pumps, 227
  - speed, 185
- Characteristics of impulse wheels and turbines, 181
- Chezy's formula, 85
- Church's formula for water hammer, 204

- Circles, circumferences and areas of, 268
- Circular orifice, efflux coefficients for, 273
  - sections, hydraulic properties of, 106
- Cock in circular pipe, 80
- Complete contraction, 49
- Compound pipes, 86
- Conduits, flow in open, 100
- Conical mouthpiece, 63
- Contracted weir, 51
- Contraction coefficient, 45
  - of jet, 48
  - of section, 79
  - effect of, 92
  - partial and complete, 49
- Crane, hydraulic, 11
- Critical velocity of water in pipes, 71
- Cross section of channel, 103
- Current meter, 108
  - wheel, 156, 158

### D

- Darcy's modification of Pitot's tube, 110
- Deflection of jet, 147
- Density of water, 3
- Design of centrifugal pumps, 234
- Diffusion vanes, 221
- Diffusor, pressure developed in, 226
- Discharge, conditions for maximum, 103
  - equivalents, 260
  - from rectangular orifice, 47
  - of rectangular notch weir, 48
  - through sharp-edged orifice, 48
- Divided flow, 86
- Doble bucket, 160
- Draft tube, theory of, 173
- Dry dock, floating, 236
- DuBuat's paradox, 117

- Dynamic pressure, 145  
in bends and elbows, 149
- E
- Effective fire stream, height of, 90  
head, 46
- Efficiency curves for turbines, 249, 250  
of hydraulic press, 7  
maximum, for vanes, 151
- Efflux coefficients, 46  
for circular orifice, 273  
for square orifice, 274
- Elasticity, bulk modulus of, for water, 202  
of water, 1
- Elevator, hydraulic, 12
- Empirical weir formula, 51, 52
- Enlargement of section, 78  
effect of, 92
- Equilibrium of floating bodies, 20  
of fluids in contact, 16
- Experiments on flow of water, 90
- F
- Fire nozzles, 64  
pumps, 239  
streams, 89  
stream table, 275
- Flat plate in current, 93
- Float measurements, 108
- Floating equilibrium, 21  
gate, Keokuk lock, 40
- Flow in small pipes, velocity of, 74
- Force pump, 209
- Fourneyron type of turbine, 169
- Francis type of turbine, 170
- Freeman's experiments on fire streams, 89
- Friction head in pipes, 278  
loss in pipe flow, 77
- G
- Gate valve in circular pipe, 80
- Gibson's experiments on water hammer, 204
- Girard impulse turbine, 164
- Gradient, hydraulic, 82
- H
- Head and pressure equivalents, 47, 259  
developed by centrifugal pump, 231  
effective, on orifice, 46  
lost in pipe flow, 76
- Hele-Shaw's experiments, 92
- Hook gage, 54
- House service pipes, 129
- Hydraulic accumulator, 9  
crane, 11  
dredge, 239  
efficiency of centrifugal pumps, 235  
elevator, 12  
gradient, 82  
slope of, 83  
intensifier, 8  
jack, 10  
mining, 242  
motors, types of, 156  
press, 5  
radius, 84
- Hydrostatic pressure, 3
- I
- Ideal velocity head, 44
- Impact on plane surface, 144  
on surface of revolution, 146  
tube, theory of, 113
- Impeller, pressure developed in, 224
- Impellers for centrifugal pumps, 218
- Impulse wheel, 152, 156  
wheels, classification of, 189
- Intensifier, hydraulic, 8
- J
- Jack, hydraulic, 10
- Jonval type of turbine, 169
- Joukovsky's experiments on water hammer, 204
- K
- Kensico dam, 35, 36
- Keokuk turbines, 179  
power plant, 37
- Kinetic pressure, 64  
head, 66, 82

- Kutter's coefficients, 283  
 formula, 101, 102
- L
- Liquid vein, 44  
 Lock, Keokuk, 38  
 Loss of head in small pipes, 74  
 Lost head in pipe flow, 76  
 summary of, 81
- M
- Mariotte's flask, 60  
 Mechanics, principles of, 288  
 Mercury barometer, 18  
 pressure gage, 19  
 Metacenter, 23  
 coordinates of, 25  
 Metacentric height, 25  
 Mine drainage, 237  
 Mississippi River Power Co., 37, 179  
 Modulus of elasticity for water, 202  
 Motors, classification of hydraulic,  
 157  
 Moving vanes, 149
- N
- Natural channels, flow in, 106  
 New York State barge canal, 96  
 Niagara Falls power plant, 172  
 Non-sinuuous flow, 72  
 Nozzle diameter, determination of,  
 198  
 for maximum power, 196  
 Nozzles, flow through, 60
- O
- Ontario Power Co., 172  
 Operating range, normal, 190  
 Oval sections, hydraulic properties  
 of, 106  
 Overshot wheel, 159
- P
- Packing, frictional resistance of, 7  
 Parallel flow, 72  
 Partial contraction, 49  
 Pelton wheel, 159  
 efficiency of, 162  
 Period of oscillation of ship, 27
- Piezometer, 18  
 Pipe flow, ordinary, 75  
 friction, coefficient of, 277  
 lines, power transmitted  
 through, 195  
 Pipes, dimensions of, 265  
 friction head in, 278  
 Pitotmeter, 112  
 Pitot recorder, 113  
 tube, 109, 116  
 Poncelet wheel, 158  
 Power and efficiency, relation be-  
 tween, 197  
 Pressure gage, mercury, 19  
 hydraulic, 5  
 machines, 8  
 static and dynamic, 145  
 Properties of water, 260  
 Pump sizes, calculation of, 211  
 Pumps, capacity of reciprocating,  
 266  
 centrifugal, 215  
 displacement, 207  
 steam, 210  
 suction, 207
- R
- Ram, efficiency of hydraulic, 206  
 hydraulic, 205  
 Rate of flow controller, 70  
 Rational weir formulas, 51  
 Reaction of jet, 154  
 Reaction turbine, principle of oper-  
 ation, 155, 157  
 turbines, 169  
 classification of, 188  
 Rectangular notch weir, 51  
 discharge from, 48  
 weirs, coefficients for, 285-287  
 orifice, discharge from, 47  
 Relative velocity of jet and vane, 149  
 Reversal of jet, 147  
 Rolling and pitching of ships, 27  
 Rotation of liquids, 198
- S
- Siphon lock, 100  
 spillway, 96  
 steel pipe, 142

- Siphons, 95  
 Specific discharge, 186  
   power, 187  
   speed, 186, 187  
   weight, 3  
     determination of, 22  
     physical definition of, 21  
   weights of various substances, 264  
 Speed criterion, 182  
 Square orifice, efflux coefficients for, 274  
 Stage pumps, 223  
 Standard mouthpiece, 60  
 Steam pump, 210  
 Stock runner, selection of, 191  
 Stream gaging, 106  
   line, 44  
     motion, 93  
     mouthpiece, 61  
 Submerged surfaces, pressure on, 12  
 Suction lift, 208  
 Suppressed weir, 51  
   weirs, discharge coefficients for, 290  
 Surface of liquid in rotation, 199
- T
- Tanks, connected, rise and fall in, 58  
   filling and emptying, 56  
 Throttle valve in circular pipe, 81  
 Torricelli's theorem, 45  
 Translation, effect of, 198  
 Tubes, short, flow through, 60
- Turbine pumps, 223  
   setting, 177  
   test data, 251-255
- U
- Undershot wheel, 158
- V
- Vanes, pressure of jet on, 149  
 Varying head, 58  
 Velocity head, ideal, 44  
   of approach, 49  
   of flow, actual, 45  
   variation with depth, 108  
 Venturi adjutage, 63  
   meter, 67  
     Catskill aqueduct, 69, 70  
 Viscosity, 2  
   coefficient, 71  
 Volute casing, 219  
 Vortex chamber, 219
- W
- Water barometer, 17  
   hammer in pipes, 202  
   properties of, 260  
 Waves in pipes, pressure, 203  
   period of compression, 203  
   velocity of compression, 203  
 Weights and measures, 263  
 Weir formulas, 51, 52  
   measurements, 53  
 Weirs, construction of, 53  
   proportioning, 55



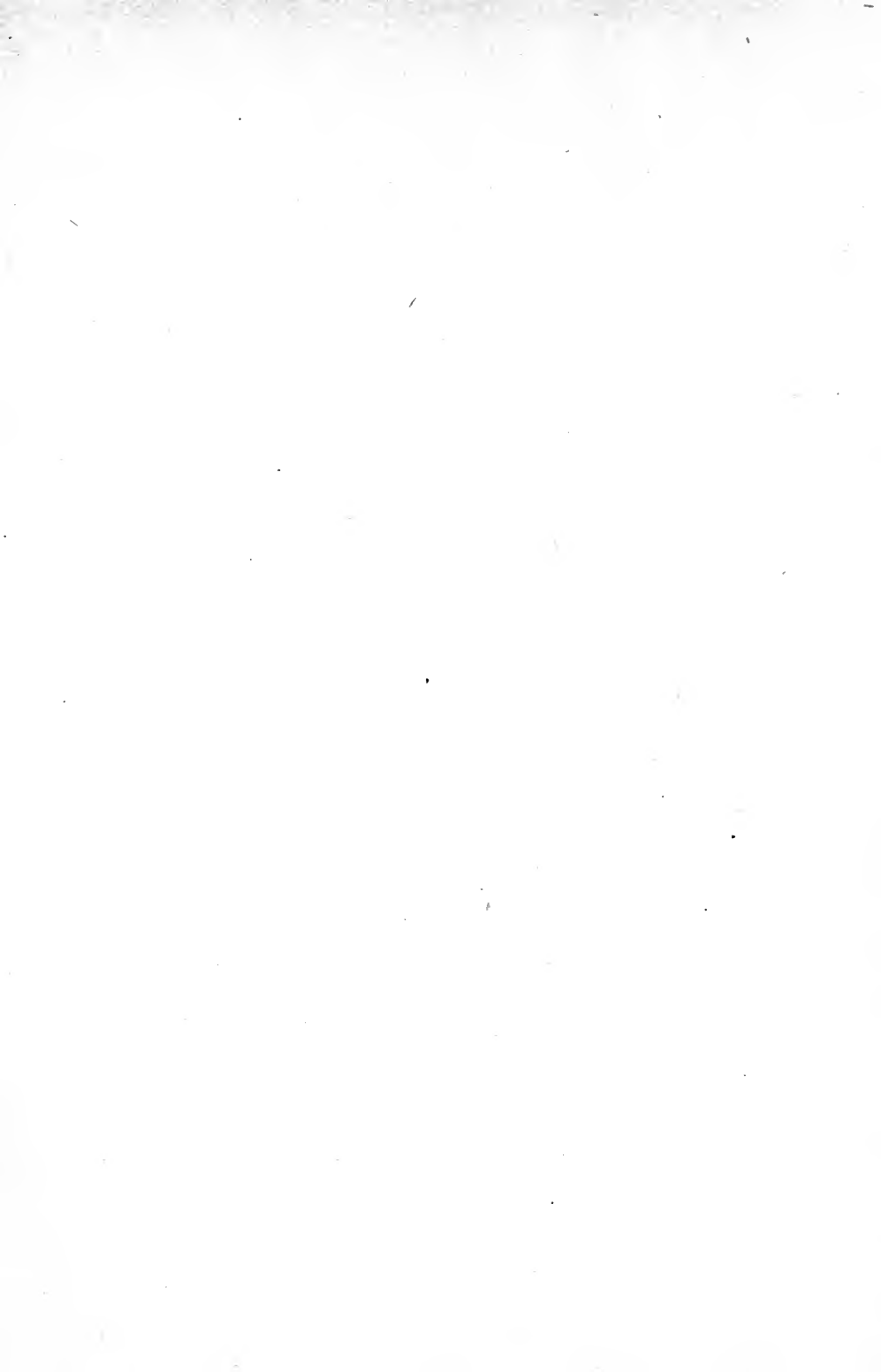



**THIS BOOK IS DUE ON THE LAST DATE  
STAMPED BELOW**

**AN INITIAL FINE OF 25 CENTS  
WILL BE ASSESSED FOR FAILURE TO RETURN  
THIS BOOK ON THE DATE DUE. THE PENALTY  
WILL INCREASE TO 50 CENTS ON THE FOURTH  
DAY AND TO \$1.00 ON THE SEVENTH DAY  
OVERDUE.**

FEB 18 1935

FEB 19 1935

FEB 24 1937

TA

APR 5 1938

NOV 18 1940



$\frac{1}{250} \times$

TC160

300315

S4

*Slocum*

UNIVERSITY OF CALIFORNIA LIBRARY

