

THE ELEMENTS *of* MECHANICS
OF MATERIALS

C·E·HOUGHTON

LIBRARY
OF THE
UNIVERSITY OF CALIFORNIA.

Class

The D. Van Nostrand Company

intend this book to be sold to the
Public at the advertised price, and
supply it to the Trade on terms which
will not allow of reduction.



THE ELEMENTS OF MECHANICS OF MATERIALS

A TEXT FOR
STUDENTS IN ENGINEERING COURSES

BY

C. E. HOUGHTON, A.B., M.M.E.
ASSOCIATE PROFESSOR OF MECHANICAL ENGINEERING
NEW YORK UNIVERSITY



NEW YORK
D. VAN NOSTRAND COMPANY
1909

TA 350
HL

GENERAL

COPYRIGHT, 1909,
BY D. VAN NOSTRAND COMPANY.

Norwood Press :
Set up and electrotyped by J. S. Cushing Company,
Norwood, Mass., U.S.A.

PREFACE

THIS is not a treatise on the Mechanics of Materials. The efforts of Merriman, Burr, Lanza, and others cover the field so thoroughly that there is no present need of such a work.

It is designed to be an elementary text-book for students in the engineering courses in colleges and universities, where the time allotted to the subject does not exceed three or four recitations per week, for one half year, and where the course is preceded by college courses in mathematics, through integral calculus, mechanics, and physics.

The extreme mathematical treatment of the subject has been avoided, but where the use of higher mathematics leads to clearness they have been freely used.

As it is intended as a text-book, the general cases are discussed fully, leaving the student to derive the formulas for special cases as part of the regular problem work.

At the end of each chapter there are review questions covering the more important parts of the subjects discussed and problems illustrating the same. The solution of one problem of each type has been given to show the application of the general formulas.

The appendix contains tables giving the values of the engineering constants of materials and the formulas commonly used in design, in addition to the tables usually found in books of this character.

The notation has been made uniform with that of Merriman's works, so that his more complete treatise on the subject may be conveniently used as a reference book.

NEW YORK, January, 1909.

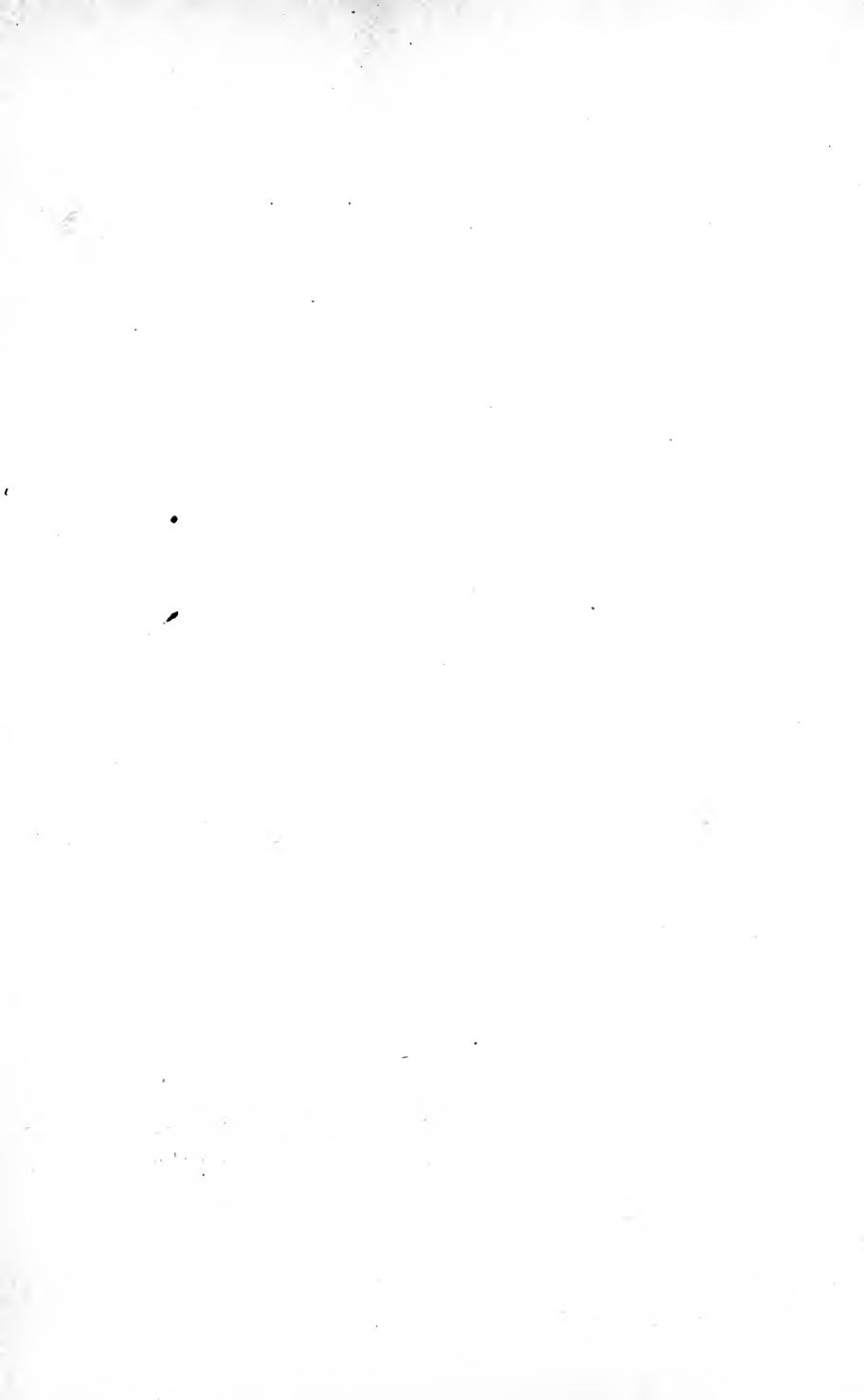

TABLE OF CONTENTS

CHAPTER I

APPLIED MECHANICS

ARTICLE	PAGE
1. Forces in structures	1
2. Axial forces	3
3. A bar	3
4. Internal forces	3
5. Tensile or compressive stresses	4
6. Unit stress	4
7. Maximum tensile or compressive stresses	5
8. Shearing stresses	5
9. External and internal forces	6
10. Deformation of elastic bodies	7
11. Unit deformations	7
12. Modulus or coefficient of elasticity	8
13. The elastic limit	8
14. Ultimate strength	9
15. Resilience	10
16. Ductility	11
17. Elastic resilience	12
18. Use of formulas	12
19. Constants of materials	13
20. Units	14
21. Working stresses; factors of safety	14
22. Accuracy of calculations	15
Examination questions	16
Problems	18

CHAPTER II

APPLICATIONS

23. Bars of uniform strength	22
24. Thin pipes, cylinders, and spheres	25

ARTICLE	PAGE
25. Thick pipes	27
26. Riveted joints	30
27. Tension in plates	30
28. Shear on rivets	32
29. Compression on rivets or plates	33
30. General case of a riveted joint	33
31. Kinds of riveted joints	35
32. Efficiency of a riveted joint	37
33. Stresses due to change of temperature	39
Problems	40

CHAPTER III

BEAMS

34. Kinds of beams	46
35. Reactions at the supports	47
36. Uniform and concentrated loads	47
37. Vertical shear	49
38. Bending moment	50
39. Resisting shear	51
40. Resisting moment	52
41. Use of formula	55
42. Shear and moment diagrams	58
43. Shear diagrams	59
44. Moment diagrams	60
45. The relation between the vertical shear and bending moment	63
46. Relative strengths of simple and cantilever beams	64
47. Overhanging beams	65
48. Beams of uniform strength	66
49. Moving loads	67
50. Use of formula	69
51. Examination questions	70
Problems	73

CHAPTER IV

TORSION

52. Derivation of formula	83
53. Modulus of section	86
54. Square sections	86

TABLE OF CONTENTS

vii

ARTICLE	PAGE
55. Illustrations	87
56. Twist of shafts	88
57. Relative strengths and stiffness	89
58. Horse power of shafts	89
59. Shaft couplings	90
60. Modulus of rupture for torsion	92
61. Helical springs	93
Examination questions	94
Problems	95

CHAPTER V

THE ELASTIC CURVE

62. Definition	99
63. The equation of the elastic curve	99
64. Deflection of beams	102
65. Fixed or restrained beams	105
66. Beams fixed at both ends	107
67. Continuous beams	109
Examination questions	114
Problems	116

CHAPTER VI

LONG COLUMNS

68. Stresses in long columns	123
69. Euler's formula for long columns	124
70. Columns with round or pin ends	125
71. Columns with square, flat, or fixed ends	126
72. Columns with round and square ends	128
73. Rankine's formula for long columns	131
74. Applications	135
Examination questions	137
Problems	139

CHAPTER VII

COMBINED STRESSES

75. Stresses due to force	143
76. Tension or compression combined with bending	143

ARTICLE	PAGE
77. Roof rafters	147
78. Eccentric axial loads	149
79. Shear and axial stress	149
80. Maximum stresses	150
81. Horizontal shear in beams	152
82. Maximum stresses in beams	156
Examination questions	158
Problems	160

CHAPTER VIII

COMPOUND BARS AND BEAMS

83. Definition	163
84. Compound columns, alternate layers	163
85. Compound columns, longitudinal layers	163
86. Compound beams	165
87. Reënforced concrete beams	166
88. Straight line formula for reënforced concrete beams	166
Examination questions	173
Problems	174
Tables, Explanation of	176
Table 1. Notation	176
Table 2. Fundamental formulas	178
Table 3. Derived formulas	179
Table 4. Properties of beams	182
Table 5. Average constants of materials	183
Table 6. Properties of sections	184



MECHANICS OF MATERIALS

CHAPTER I

APPLIED MECHANICS

ARTICLE 1. Forces in Structures.

One of the problems that confronts the engineer called upon to design any machine or structure is to so proportion the various parts that they will resist the forces that act on them.

To do this, he must apply the laws of mechanics to the forces to be resisted, and study the action of the materials under the same forces.

This application of mechanics may be termed *Applied Mechanics or the Mechanics of Materials*.

If we consider any structure or any member of the structure to be at rest, according to the laws of mechanics the forces that act on the structure or member must be in equilibrium. The various parts of a machine often have relative motion, but by introducing a force equal and opposite to the force which produces that motion, the forces that act on the member of a machine may also be treated as a system of forces in equilibrium.

In the more extended treatment of this subject the forces are taken as acting in different planes. The simpler theory that treats the forces as coplanar is the one that will be used here.

Since each member must be designed separately, if the forces that act on any member are determined, we will find that the forces may be resolved into :

- Forces tending to lengthen the member,
- Forces tending to shorten the member,
- Forces tending to bend the member,
- Forces tending to shear the member.

Imagine any body, acted on by a system of forces in equilibrium, denoting the sum of the components of the forces parallel to some line as the X forces, and those perpendicular to the same line as the Y forces; the sum of the X forces is zero and the sum of the Y forces is zero. If we take as the line of reference the axis of the body passing through the center of gravity of the body, the resultant of the X forces will be a couple, unless the lines of action of the forces of the couple coincide with the axis.

Each force of this couple may be replaced by a single force of equal magnitude, acting in the line of the axis and a couple whose moment is the moment of the force about a point in the axis. The X forces acting in the line of the axis will tend to either lengthen or shorten the member in the line of the axis, and the couple as well as the Y forces will tend to bend the member.

If the member be cut by a plane perpendicular to the axis, the Y forces on either side of the section will be opposite in sign, and in general tend to slide one part of the member, relative to the other, along the plane of the section. Any of the resultants may be zero, and in that case there would be no tendency to deformation in that line.

The force acting on any member is always transmitted by a surface of finite area, but by considering that each

elementary area of the surfaces in contact transmits the same amount of pressure, we may use the resultant of these elementary pressures passing through the center of gravity of the areas in contact, as the force applied.

ART. 2. Axial Forces.

When the lines of action of the acting forces lie in the axis of the body, passing through the centers of gravity of all sections perpendicular to the axis, the forces

are called *Axial Forces*, and their effect is to either lengthen or shorten the member.

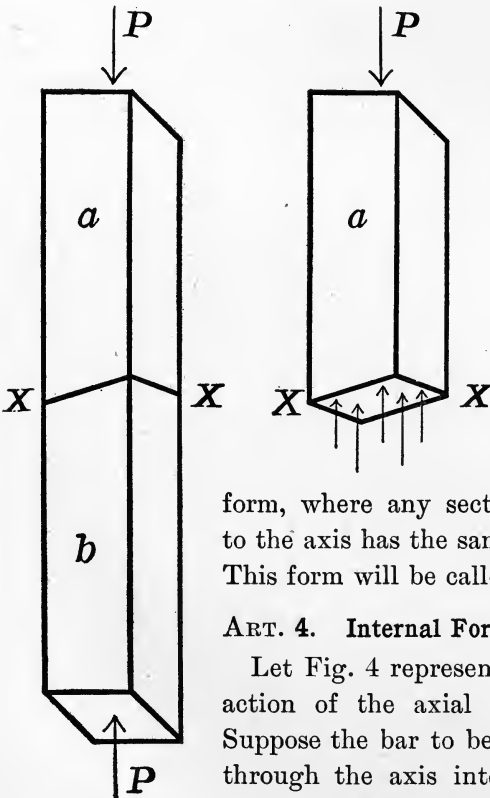

FIG. 4.

ART. 3. A Bar.

The member may have any shape whatever, the simplest being a prismatic or cylindrical

form, where any section perpendicular to the axis has the same shape and area. This form will be called a *Bar*.

ART. 4. Internal Forces or Stresses.

Let Fig. 4 represent a bar under the action of the axial forces P and P . Suppose the bar to be cut by any plane through the axis into the segments a and b , and consider the segment a .

This segment is acted on by the external force P , and as a part of the whole bar it is in equilibrium; hence there must be forces acting in the plane section $X-X$, whose resultant acts in the same line, and is equal and opposite to the force P . As the same is true of the segment b , the internal forces, called stresses, acting between a and b , hold the segments a and b in equilibrium against the external forces.

Therefore, in any plane section of the bar there exists a pair of equal and opposite forces or stresses, each of which are induced by and resist the external forces. In general, the stresses may be resolved into components parallel and perpendicular to the plane section. The components parallel to the plane of the section prevent the sliding of the segments along the plane, and are termed *Shearing Stresses*, while those perpendicular to the plane are called either *Tensile* or *Compressive Stresses*, depending on whether they tend to extend or compress the particles on which they act.

ART. 5. Tensile or Compressive Stresses.

When the external forces are axial, and the section perpendicular to the axis, the stresses can have no component parallel to the plane of the section; hence axial forces can produce only tensile or compressive stresses in planes perpendicular to the axis. The plane dividing the bar into the segments a and b was any plane; hence the reasoning holds true for all such planes, and there are only tensile or compressive stresses equal to the external force P , in all sections perpendicular to the axis.

ART. 6. Unit Stress.

Since the force P is the resultant of all the equal unit pressures on the areas in contact, it is reasonable to assume

that the stresses on each unit of area of the plane section are also equal, and if S equals the sum of the stresses acting on each unit of area of the plane section, and A is the area of that section, then

$$P = AS. \quad (a)$$

S is termed the unit stress, and is the resisting force per square unit of area; hence S must be expressed in the same units as P and A .

ART. 7. Maximum Tensile or Compressive Stresses.

When the cutting plane is not perpendicular to the axis, the resultant stress may be resolved into components parallel and perpendicular to the plane of the section, those perpendicular being either tensile or compressive stresses, while those parallel are shearing stresses.

As neither component can equal the resultant, it is evident that the maximum tensile or compressive stresses will be found in a section perpendicular to the axis. In such a section there are no shearing stresses, and when the bar has a uniform section area A , the formula (a) will determine the maximum tensile or compressive unit stress induced by the axial force P . If the areas of all sections perpendicular to the axis are not equal, the greatest unit stress will be found where the section area is the least, and the value of A to be used in formula (a) is the area of the least section.

ART. 8. Shearing Stresses.

When the external forces act in adjacent parallel lines, since the stresses can have no component perpendicular to the line of action of the forces, the stress in a section parallel to the line of action of the forces must be a

Shearing Stress, as the external forces tend to slide the two sections of the bar along the plane of the section. (Fig. 8.)

Assuming that the stress is uniformly distributed over the section, and that S_s is the unit stress in shear, then formula (a) $P = AS_s$, where A is the area of the section

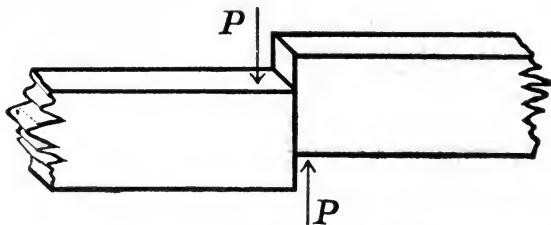

FIG. 8.

parallel to the line of the forces and P the forces producing the shear, will always give the relation between the external forces and the maximum unit shearing stress in the section.

ART. 9. External and Internal Forces.

The external forces on any member of a machine or structure are the weights or loads that member has to support and the pressure it receives from the adjacent members, while the internal forces are those that transmit the external force from element to element through the member. These latter forces are stresses, and the internal force per unit of area is the *Unit Stress*, and will be designated by the letter S , with a subscript t , c , or s , as the stress is tension, compression, or shear.

The formula $P = AS$ is a general one and applies to all cases where the stress is uniformly distributed over the area of any plane section A , and S , the kind of unit stress.

ART. 10. Deformation of Elastic Bodies.

In the study of mechanics, the forces were assumed to act on rigid bodies; that is, on bodies whose shape was not altered by the application of the force. As there are no rigid bodies in nature, every force applied produces some deformation or change of shape. This fact, however, does not prevent the application of the laws of mechanics to elastic bodies under the action of force after the deformation has taken place, since equilibrium must exist at that time.

ART. 11. Unit Deformations.

Consider a bar, l units in length, and A square units in section, under the action of an axial force P . From equation (a), $S = \frac{P}{A}$. S is constant, since P and A are constant for all sections perpendicular to the axis, or each square unit of every section is acted on by a force S .

Suppose the bar to be divided into bars, each one unit in section and l units long, then each of these bars is acted on by a force S . The change in the length l , that may take place under the force S , being e , since all particles are under the same force, the change in the length must be equal to the length l , multiplied by the unit load S , and some number which depends on the nature of the material. Calling this number $\frac{1}{E}$, the value of e must be $e = \frac{Sl}{E}$. This may be written $\frac{e}{l} = \frac{S}{E}$. Letting $\frac{e}{l} = \epsilon$ equal the change in the length of a bar one unit in length, or the unit deformation, it follows that $\epsilon = \frac{S}{E}$ or

$$E = \frac{S}{\epsilon} = \frac{\text{unit stress}}{\text{unit deformation}}. \quad (b)$$

ART. 12. Modulus or Coefficient of Elasticity.

If the value of S does not exceed a critical value which varies for different materials, E will be constant for all values of S , and this constant is called the *Modulus or Coefficient of Elasticity*. This constant is the value of the ratio of the unit stress to the unit deformation, as may be seen by the inspection of formula (b).

Equation (b) may be written $E = \frac{Pl}{Ae}$, since $S = \frac{P}{A}$ and $\epsilon = \frac{e}{l}$, and as A and l are constants for any bar under axial forces, E will be constant when e varies directly with P .

ART. 13. Elastic Limit.

If a bar length l is subjected to a small axial force P , it is observed that the length has changed a certain small amount. If P_2 is twice P , experiment shows that the change in length is twice that due to P , and if P_n is n times P , the change in the length is n times that due to P , provided that P_n does not exceed a certain limiting value which varies for each material and bar. That is, within that limit the change in length of any bar is proportional to the external force applied. If P_n is the limiting value for a given bar, then the corresponding value of S as derived from formula (a) must be the limiting value of the unit stress. This value of S , being a unit stress, is independent of the dimensions of the bar and depends only on the material of the bar, is called the *Elastic Limit* of the material or the limit of elasticity.

The elastic limit of a material may be defined as the unit stress for which the deformations cease to be proportional to the applied force.

To determine this value of S for any material, axial loads are applied to a bar of the material, the loads being applied in small equal increments, and the change in length due to each increment of load measured. For any total load less than the load producing a stress equal to the elastic limit, the last increment of load should produce the same change in length as any previous increment. Therefore, when an increase in the change in length for any equal increment of load is noted, the elastic limit has been passed. It will be noticed that the exact value of elastic limit depends on the accuracy with which the loads and especially the deformations are measured.

It has also been observed that if the stress in any bar is less than the elastic limit, the bar will return to its original length when the load is removed, and if the stress is slightly above the elastic limit, there will be some permanent change in the length of the bar. The unit stress at which this yielding takes place is called the *Yield Point* or the *Commercial Elastic Limit*. The latter term comes from the commercial practice of determining the elastic limit by the drop of the beam in the testing machine.

While the yield point or commercial elastic limit is from 3 to 5% higher than the true elastic limit, the ease with which the latter value may be determined and the fact that the allowable value of S for any engineering structure rarely exceeds one half of the elastic limit, combine to make it the one in general use.

ART. 14. Ultimate Strength.

After the elastic limit is reached, the change in length increases more and more rapidly as the loads are increased, and finally a load is reached that causes the bar to rupture.

If P is the load that causes rupture and A is the original area of the bar, then the value of S obtained from formula (a) is called the *Ultimate Strength* of the material.

ART. 15. Resilience.

If a bar of wrought iron, whose section area is A , and the length l as measured between two punch marks on the bar, is placed in a testing machine, the tensile loads and their corresponding extensions being measured and plotted to scale on section paper, the result would be a diagram similar to that in Fig. 15.

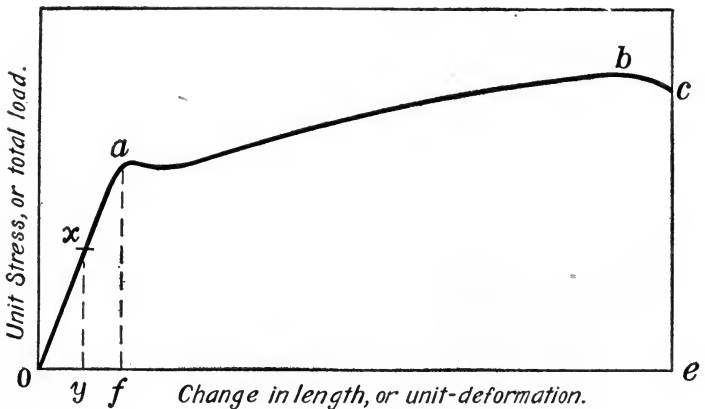

FIG. 15.

Since $P = AS$, the ordinates representing loads may, by a change of scale, represent unit stresses, and the abscissa representing total elongations may also represent unit elongations. Such a diagram is called a *Stress-strain diagram*. The use of the word "strain" gives it the meaning of "unit deformation." Authorities do not agree on the use of the word, some giving it the meaning as above, while others use it to mean load. On account of

this ambiguity, the term "unit deformation" will be used in its place. The unit stress for any load is obtained by dividing the load by the original area, and the unit elongations by dividing the elongation for any load by the original length l .

The point a on the curve is the elastic limit, and b is the ultimate strength of the material. After a load corresponding to b is reached, the bar begins to reduce at some point very rapidly, finally breaking at a load less than the load at b . This load is called the *Breaking Load*, and has but little significance in engineering work.

Since one coördinate represents force, and the other space, the area $o a b c e$, when measured in the proper units, is the work done in breaking a bar of unit volume. If we define the *Ultimate Resilience* as the work done in breaking a bar of unit volume, the area represents that quantity.

ART. 16. Ductility.

As the whole curve is rarely ever determined, the *Ductility*, a term that is defined by its method of calculation and is proportional to the ultimate resilience, is generally used in its place.

The ductility of any material is calculated as follows: After the bar has been broken by a tensile load, the pieces are removed from the testing machine and the broken ends placed together. The distance between the original punch marks, being l , has now increased to $l + p$; then $\frac{p}{l}$ is called the *Ductility*, and is usually stated as a percentage of the original length.

ART. 17. Elastic Resilience.

The area oaf is easily calculated, as it is the area of a triangle, and when measured in work units is called the *Elastic Resilience*. This work is evidently

$$\frac{\text{the unit stress at } a \times \text{the unit deformation at } a}{2}$$

Calling this value k , it is the elastic resilience of the material, or the work done in raising the unit stress in a bar of unit volume from 0 to the elastic limit.

The same reasoning is true for any stress less than the elastic limit, giving a method of calculating the work necessary to produce any given stress less than the elastic limit in a bar of unit volume. If S is any stress less than the elastic limit, and ϵ the unit deformation at that stress, then $k = \frac{1}{2} S\epsilon$ is the work done per unit of volume, and the work done on any bar whose volume is V is V times that quantity. Taking the work done on any bar as $\frac{1}{2} S\epsilon \times V$, substituting for S its value $\frac{P}{A}$, for ϵ , $\frac{e}{l}$, and for V , Al , the expression for the work done on any bar reduces to $K = \frac{Pe}{2}$, which is in terms of the total load and deformation, and is true when P is less than the load, causing a stress within the elastic limit.

ART. 18. Use of Formulas.

Whenever any stress can be assumed to be uniformly distributed over the area of any section of a bar, formula (a), $P = AS$, gives the relation between the load and the stresses on that area, and any two of these quantities involved being given, the other may be found.

The relation between the load and the deformation for

such cases is given by $E = \frac{S}{\epsilon} = \frac{Pl}{Ae}$, which is true when $S = \frac{P}{A}$ is less than the elastic limit, and is applicable to all problems involving the deformations of a bar under axial loads.

Also $k = \frac{1}{2} S\epsilon$ and $K = \frac{1}{2} \frac{Pe}{Al}$ can be used under the same conditions when the data for the problem include a consideration of the work done in deforming a bar. When the load is axial and the stress may be taken as uniformly distributed over the area of any section, these three equations furnish the means for the design and investigations of the strength of all members of a structure or machine.

Writing (a) $S = \frac{P}{A}$, (b) $E = \frac{S}{\epsilon}$, and $k = \frac{1}{2} S\epsilon$, it will be noticed that the equations are simply the algebraic expressions of the definitions of Unit Stress, Modulus of Elasticity, and the Unit Resilience, making it easier to remember either the formula or the definition.

ART. 19. Constants of Material.

These three equations make use of the following constants of materials:

- Elastic Limit,
- Ultimate Strength,
- Modulus of Elasticity, and
- Modulus of Elastic Resilience,

all of which have to be determined by experimental work on bars of the various materials. As this work cannot be done for each problem, a table containing average values of these constants for the more common materials will be found in the Appendix, and the question of the units in which each is expressed becomes important.

ART. 20. Units.

In American practice, the linear unit is the inch; the square unit, the square inch, and the unit of weight, the pound.

In the tables, the values of E , L , U , and E , are given in pounds / square inch and k in inch pounds. Therefore when the solution of any problem requires the use of any of these constants, all of the quantities involving weights or loads must be in pounds, and those involving linear or square measure, in inches.

ART. 21. Working Stresses ; Factors of Safety.

No material is entirely free from flaws and imperfections, which tend to diminish the area that is effective in resisting the external force, and in no case should the stress in any member be greater than the elastic limit, as such a stress would cause some permanent deformation. Suddenly applied loads, shocks, and loads producing alternate tension and compression, all produce stresses that are greater than the value of $S = \frac{P}{A}$, which is the value of S for the same loads gradually and steadily applied. When any of these conditions occur, they tend to reduce the allowable or safe value of S to be used in the equation $P = AS$. Therefore, if U is the ultimate strength of the material, the allowable value of the unit stress can be found by dividing the ultimate strength by some number. Calling this number the *Factor of Safety*, F , $S = \frac{U}{F}$ is the value of S to be used in connection with the formula $P = AS$, and is termed the *Safe* or *Working Stress*.

The factor F depends —

1. On the reliability of the material ; that is, the liability of flaws or imperfections that may reduce the effective area of the section.

2. On the way in which the loads are applied.

The first part has been termed a factor of ignorance, while the second may be determined more or less accurately from theoretical considerations.

The factors of safety as given in the tables in the Appendix are those to be used in the solution of the problems given in this book, and it must be remembered that the values are only approximate.

The safety of any structure calling for a large factor, while the consideration of cost always demands the smallest one, the final choice of the factor of safety to be used in any given case must be largely a question of engineering judgment. In some cases, as in buildings, the allowable stress under the various kinds of loadings is a part of the building laws, and the engineer has to conform to the law.

For steady loads and reliable material the smallest factor in general use is about four.

On account of the danger of permanent injury to the material, no stress should exceed the elastic limit ; hence, it would seem better engineering to base the factor of safety on the elastic limit rather than on the ultimate strength, but such practice is not general in engineering work.

ART. 22. Accuracy of Calculations.

As the use of a factor of safety of four will result in an area of section about twice what it would have been had the allowable stress been equal to the elastic limit, and the values of E , L , U , and E , being determined by experi-

ment, are liable to an error of from 3 to 5 %, there is no necessity for absolute accuracy in the calculations for the design of the different parts of a structure.

Students are urged to use a slide rule in the numerical solution of the problems given in this text, not only to save time during the college course, but because they will find the use of a slide rule almost necessary in the practice of their profession. The slide rule should always give results that are not in error more than 1, or at the outside 2 %, which is close enough for the greater part of engineering calculations.

They are warned that it is the significant figures in a number that is to be used as a factor, and not the decimal point, that is of importance. If in one case the area was given as 12,500 sq. in. and as .00125 sq. in. in another, the figure 5 is of equal importance in each case. The use of the latter area as .0012 sq. in. will result in an error of 4 % in the value of the stress.

EXAMINATION QUESTIONS

1. There is no relative motion between the different parts of a bridge, therefore each part must be in equilibrium. How is it that the same laws may be applied to machine parts, which we know have relative motion?
2. When may forces be considered as Axial?
3. Define the term "Bar" as used in the text.
4. What is a stress? If there are stresses in every section of a bar, why is it that there is no relative motion between the different parts?
5. When may stresses be termed Tensile or Compressive Stresses?
6. What is a Unit Stress?

7. If a member of any structure varies in size at different parts of its length, how can you find the maximum tensile or compressive unit stress due to an axial load?

8. Give some examples of forces that produce tensile, compressive, and shearing stresses.

9. What are the external forces for any member of a structure? What are the internal forces?

10. Show that $P = AS$, give the units involved, and the limits of use for the formula.

11. The science of mechanics is based on the action of forces on rigid bodies. Why is it that the same laws may be applied to forces acting on elastic bodies?

12. What is meant by the expression, Unit Deformation?

13. If the modulus of elasticity for steel is 30,000,000 and for wrought iron is 25,000,000, and one bar of each is the same size and carries the same tensile load, which bar will stretch the most?

14. The value of E may be termed a measure of the rigidity of a material. Why?

15. Define Elastic Limit and Ultimate Strength.

16. Why does the Commercial Elastic Limit or Yield Point differ from the true elastic limit?

17. What is a Stress-strain diagram?

18. If a load corresponding to the ultimate strength of the material is placed on a bar, why is not that load called the Breaking Load? Article 14 says otherwise. Explain.

19. What is meant by the term Ductility?

20. Define Elastic Resilience.

21. State the formulas for calculating the elastic resilience and modulus of elasticity; give the units involved and the limits of use for each formula.

22. What is a factor of safety? A working stress? What is the difference between a working stress and a safe stress? What do you understand by a safe load?

23. Show why, if the calculations for the stresses in any member are not in error more than 2%, they are substantially correct.

PROBLEMS

1. A square steel bar 2×2 in. in section and 4 ft. long, carries a tensile load of 60,000 lb. Required the unit tensile stress.

SOLUTION. The relation between the load, area, and unit stress, when the load is axial, is always given by $P = AS$, hence substituting for P and A , from the data given in the problem,

$$60,000 = 4 \times S, \text{ or } S = 15,000 \text{ lb./sq. in.}$$

2. A round wooden column, 16 in. in diameter and 12 ft. 6 in. long, supports a load of 20 tons. Required the unit stress.

3. What is the value of the maximum tensile load the bar in problem 1 will carry?

4. A wrought iron bar is 2 in. in diameter and 5 ft. long. What tensile load may be carried if the unit stress does not exceed 10,000 lb./sq. in.?

5. What is the maximum tensile load the bar in problem 4 will support?

6. A square cast iron column is hollow, 10×10 in. on the outside and 8×8 in. on the inside. Required the maximum compressive load that may be carried.

7. In problem 6, keeping the outside dimensions the same, required the inside dimensions if the load is 360,000 lb. and the unit stress is 10,000 lb./sq. in.

8. A punch is 1 in. in diameter. Required the probable pressure necessary to force the punch through a steel plate, $\frac{1}{2}$ in. thick.

SOLUTION. In order to force the punch through the plate, the unit shearing stress on an area equal to the cylindrical surface of the punched hole must be the ultimate shearing stress of the material; hence,

$$P = \pi dt \times S = \pi \times 1 \times \frac{1}{2} \times 50,000 = 8000 \text{ lb. approximately.}$$

9. Using a punch 1 in. in diameter and an available force of 80,000 lb., what is the thickest wrought iron that can be punched?

10. An iron casting is bolted to the floor by four one-inch bolts, and a force tends to slide the casting along the floor. Neglecting friction, what is the probable magnitude of the force when the unit shearing stress in the bolts is 10,000 lb. / sq. in.?

11. If the force in problem 10 was 24,000 lb., select four standard bolts, so that the unit shearing stress will not exceed 10,000 lb. / sq. in.

12. If steel costs five cents per pound and wrought iron four cents, which will it be cheaper to use to carry a tensile load if the same factor of safety is used in each case?

NOTE. Assume the weights per cubic foot are the same for each; then the weights in each case will be proportional to the areas of the sections.

13. With wrought iron at four cents per pound, and other conditions the same as in 12, how much can you afford to pay for steel?

14. Required the probable elongation of the bar in problem 1.

SOLUTION. The relation between the elongation and an axial load is given by $E = \frac{Pl}{Ae}$, and substituting the data as given in the problem,

$$30,000,000 = \frac{60,000 \times 48}{4e} \quad \therefore e = .024 \text{ in.}$$

15. How much work is done by the force in problem 1?

16. How much work is done by the force in problem 4?

17. A concrete pier 3 ft. by 4 ft. in area carries a load of 300 tons. Required the unit stress.

18. A brick pier carries the same load with a unit stress of 18 tons / sq. ft. Required the area of the section.

19. The thickness of the head of a standard bolt is approximately equal to the diameter of the bolt. Compare the unit tensile stress in the bolt with the unit shearing stress in the head.

20. A standard steel bolt $1\frac{1}{4}$ in. in diameter supports a tensile load of 9800 lb. Required the factors of safety for the tensile and shearing stresses.

(The least area to resist tension is at the root of the thread. See tables.)

21. If the bar in problem 1 was 4 ft. 2 in. long and the elongation was .025 in., required the modulus of elasticity.

22. If the modulus of elasticity of wood is 1,500,000, required the shortening of the column in problem 2.

23. A steel bar 1 in. in diameter has two punch marks 8 in. apart marked on it. The bar is placed in a testing machine and it is found that there is a rapid change in the rate of elongation, when the load was 24,000 lb. and after a load of 47,000 lb., no more load could be added, the bar finally breaking between the punch marks, when the load was 42,000 lb. The broken pieces were placed end to end, and the distance between the punch marks was found to be 10.4 in. Required the elastic limit, ultimate strength, and the ductility of the material.

24. If the bar in problem 1 has the load increased from 60,000 to 120,000 lb., how much more work is done?

25. How much should the bar in problem 24 stretch while the additional load is being added?

26. A certain grade of piano wire has an elastic limit of 100 tons / sq. in. If the diameter of a piece of the wire is .05 in. in diameter, required the diameter of a wrought iron wire to carry the same load when the unit stress is equal to the elastic limit in each case.

27. Show that the work done by an axial force on any bar is $K = \frac{1}{2} \frac{S^2}{E} \times \text{volume}$, provided the elastic limit is not passed.

28. If the load in problem 1 is suddenly applied, what will be the value of the maximum stress induced in the bar?

29. If a square wrought iron bar is to sustain a suddenly applied load of 60,000 lb. and the stress is not to exceed 15,000 lb. / sq. in., required the dimensions of the bar.

30. A round steel rod is to carry a tensile load of 37,700 lb. with a factor of safety of five; required the diameter of the bar.

31. Find the factor of safety in problem 1.

32. A steel rod 2 in. in diameter in a bridge truss has a unit stress due to the weight of the bridge of 4000 lb. / sq. in. A heavily loaded truck, if placed on the bridge, will add 51,000 lb. load to that already on the rod. Is it safe for the truck to cross?

CHAPTER II

APPLICATIONS

ARTICLE 23. Bars of Uniform Strength.

In the previous chapter, the bar was one of uniform section and no account was taken of its weight. When the bar was short, the effect of the weight of the bar could be neglected in comparison with the applied loads, and the unit stress found was that due to the loads alone. If the bar under axial forces is very long, the stress due to its own weight becomes too large to be neglected, and the stress in the bar is that due to the loads plus that due to its own weight.

Take the case of a wire rope used to hoist a bucket from a deep mine shaft. The weight of the bucket and its contents produces a certain unit stress in the rope that is equal at all sections of the rope.

If P is the weight of the bucket and its contents, and A the area of the section of the rope, this stress is $S = \frac{P}{A}$. The sectional area of the rope at any point has to support the weight of rope below that point, as well as the weight of the bucket and its contents; therefore the section of the rope at the upper end being A , and W the weight of the rope, $S = \frac{P + W}{A}$ instead of $\frac{P}{A}$.

It is readily seen that if W is small, the value of $P + W$

is not sensibly greater than the value of P ; the value of S will not be materially changed from $\frac{P}{A}$.

In the case where $P + W$ is much greater than P , and the rope is the same size throughout, it must be large enough to carry a load of $P + W$.

When a long vertical bar of uniform section is under an axial load, it follows that every section, except one, is larger than necessary, and if the section area is varied so that the unit stress in each section is the same, the weight of the bar could be reduced. Such a bar is called a *Bar of Uniform Strength*. This does not mean that the strength of the bar is the same at all sections, but that the change of section area makes the unit stress the same at all sections, and might better be termed a bar of uniform stress, or a uniformly safe bar.

Consider such a vertical bar, length l , and an axial load P . The smallest possible area, A_0 , is given by $A = \frac{P}{S}$, where S is the allowable unit stress, and design the bar so that S shall be constant. In Fig. 23, let A_0 be the area at the end where the load is applied, and A be the area at any distance y from that section. Then at a distance $y + dy$ the area must be increased to $A + dA$. Let w equal the weight of a cubic unit of the material; then the additional weight to be carried on the area $A + dA$ is $A w dy$, since the term containing $dA dy$ can be neglected in comparison to the term containing only dy . Since S is constant, and this weight is to be carried on the area dA ,

$$dA = \frac{A w dy}{S}, \quad \text{or } dy = \frac{S dA}{w A}, \quad (1)$$



gives the relation between the increase of length and the increase of area. If (1) is integrated,

$$y = \frac{S}{w} \log_e A + C, \quad (2)$$

and since $A = A_0$, when $y = 0$, $C = -\frac{S}{w} \log A_0$.

Substituting this value for C in (2) and transposing, $\log_e A = \frac{w}{S} y + \log_e A_0$ or $\log_{10} A = 0.434 \frac{w}{S} y + \log_{10} A_0$ (3) is an expression for the relation between the least area and

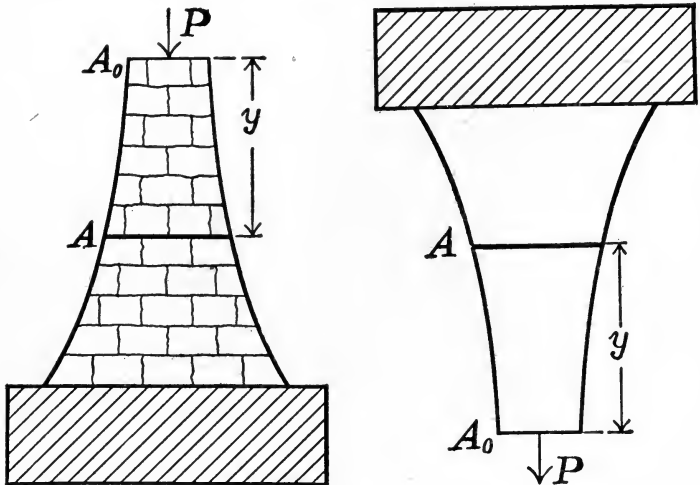

FIG. 23.

the area at any distance y from that section. In the application of the formula to a given case, different values might be assigned to y , and the corresponding values of A found, enough values being calculated to enable the profile to be drawn. In this case the outline of a vertical section is slightly curved. If the vertical section is made trapezoidal, and the bar is a masonry pier, the top of

the trapezoid is made proportional to A_0 , and the base to the value of A in equation (3), when y is the height of the pier.

Such a pier would require more material than one of uniform strength; but, although the unit stress would be only approximately equal at all sections, it would represent common practice.

ART. 24. Thin Pipes, Cylinders, and Spheres.

Take a pipe, internal diameter D , thickness of the pipe wall t , carrying a water pressure of R lb. / sq. in., to find

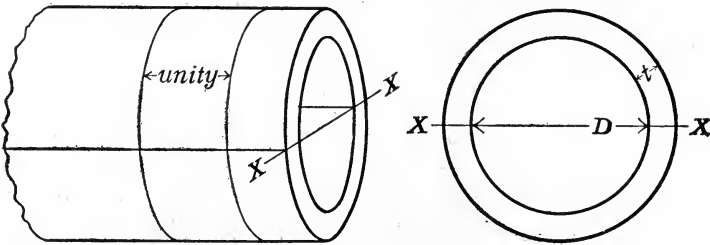

FIG. 24 a.

the unit stress in the walls of the pipe. As each unit of length of the pipe is under the same forces, we may take the length as unity. Suppose a length of pipe equal to unity (Fig. 24 a) to be cut by a diametral plane X-X; then the stresses acting on the pipe walls at the section cut by the diametral plane must resist the pressure of the water tending to force the two halves of the pipe apart, and if t is small, the stress may be considered as being uniformly distributed over the sections of the pipe walls cut by the diametral plane. Therefore, if we can calculate the value of P , the force tending to separate the two halves of the pipe, the formula $P = AS$, where A is the

area of the section of the pipe walls, will give the required unit stress.

A principle of hydraulics states that the pressure of water is the same in all directions and normal to the surface. Let Fig. 24*b* represent a half section, perpendicular to the axis of the pipe. If θ is any angle, then

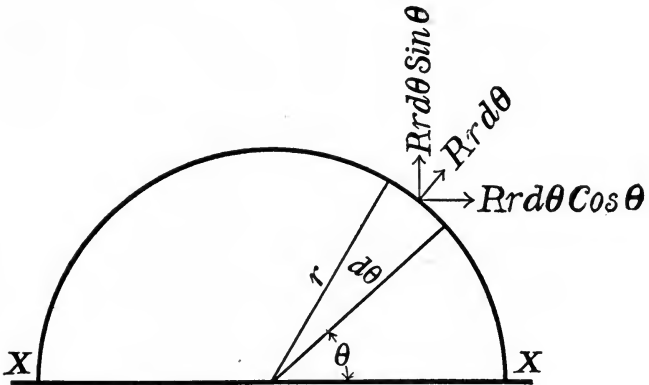

FIG. 24*b*.

for a length of pipe equal to unity, the radius of the pipe being r , an area of the internal surface of the pipe, equal to $rd\theta$, carries a pressure of R lb. / sq. in., or the total radial force on that area is $Rrd\theta$. This force may be resolved into components, parallel and perpendicular to the line $X-X$, which is the trace of the diametral cutting plane. The components are $Rr \cos \theta d\theta$ and $Rr \sin \theta d\theta$. The sum of the $Rr \cos \theta d\theta$ forces for one half of the pipe is zero, and the sum of the $Rr \sin \theta d\theta$ forces for the same half is $2Rr$, or RD , which is the force per unit of length perpendicular to the cutting plane, resulting from the internal pressure R .

Substituting this value in the general formula $P = AS$,

and noting that the area of the section of the pipe walls is $2t$, we have

$$RD = 2St \quad (1)$$

as a general expression for the unit stress induced in a longitudinal section of a pipe whose walls are thin. If the ends of the pipe are closed, the internal pressure of the water on the ends of the pipe tends to rupture the pipe in a plane perpendicular to the axis.

The force acting on the ends of the pipe is evidently $\frac{\pi D^2 R}{4}$, and the area to resist this force is πDt ; hence a substitution of these values in $P = AS$ gives $RD = 4St$, showing that the stress in a plane perpendicular to the axis is only one half that on a plane through the axis.

For a sphere with thin walls, the water pressure tends to produce rupture on the line of a great circle. It is readily seen that the pressures and areas are the same as for a plane section perpendicular to the axis of a cylinder; hence the same relation holds true.

ART. 25. Thick Pipes.

If t is large, the stress in a plane through the axis is no longer uniformly distributed over the area of the section, but is greater on the internal radius.

Many formulas have been proposed for finding the maximum unit stress in this case, the one given here being due to Barlow. The results are in simple form, and the value of the maximum unit stress being greater than that given by the more exact discussions, places the error on the side of safety.

Barlow's formula assumes that when the fluid pressure acts on the internal surface of the pipe, while the diameter

is increased, the volume of the pipe walls for a unit of length remains unchanged.

If we let D be the internal, and D_1 be the external, diameters of a pipe whose walls are thick (Fig. 25), and

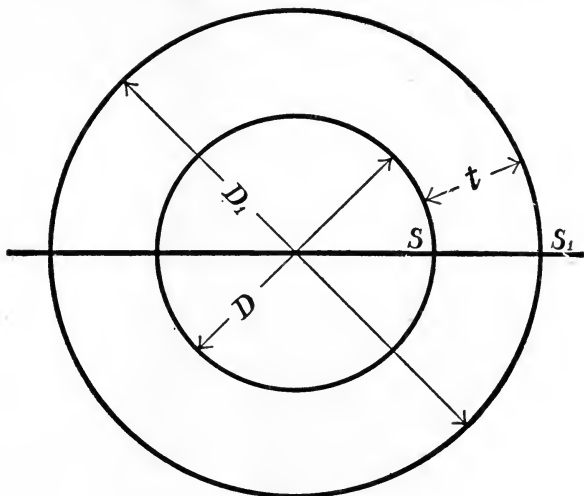

FIG. 25.

the thickness of the pipe walls t , before the pressure is applied the volume of a ring one unit in length is

$$\frac{\pi D_1^2}{4} - \frac{\pi D^2}{4}. \quad (1)$$

Let e and e_1 be the extensions of the diameters due to the fluid pressure and the volume becomes

$$\frac{\pi}{4} (D_1 + e_1)^2 - \frac{\pi}{4} (D + e)^2. \quad (2)$$

Expanding (2), neglecting the e^2 , as e is a very small quantity, and equating (1) and (2), the equation reduces to

$$D_1 e_1 = D e. \quad (3)$$

The unit elongations are $\frac{e}{D}$ and $\frac{e_1}{D_1}$, since the change in the circumference of the thin shells of diameters D and D_1 are πe and πe_1 , while the original circumferences are πD and πD_1 . The unit stresses in the thin shells of the diameters D and D_1 , being S and S_1 , as the unit stresses are proportional to the unit deformations within the elastic limit,

$$\frac{S}{S_1} = \frac{\frac{e}{D}}{\frac{e_1}{D_1}} = \frac{D_1 e}{D e_1}. \quad (4)$$

But $D_1 e_1 = D e$, hence,

$$\frac{e}{e_1} = \frac{D_1}{D},$$

and substituting this value of $\frac{e}{e_1}$ in (4) gives

$$\frac{S}{S_1} = \frac{D_1^2}{D^2} = \frac{r_1^2}{r^2}, \quad (5)$$

or the unit stresses are inversely proportional to the squares of the diameters or radii.

Let S_x be the unit stress at a radius x . Then, from (5),

$$S_x = \frac{S r^2}{x^2},$$

and the total force exerted over the area dx times 1 is

$$S_x dx = S r^2 \frac{dx}{x^2}. \quad (6)$$

The integral of the left hand member of (6) is the summation of all the stresses on one side of the pipe, and is

equal to one half of the total fluid pressure tending to rupture the pipe; hence the total force is

$$DR = 2 Sr^2 \int_r^{r_1} \frac{dx}{x^2} = \frac{2 Srt}{r+t} = \frac{2 SDt}{D+2t}. \quad (7)$$

Equation (7) reduces to $RD_1 = 2St$ instead of $RD = 2St$ for thin pipes. Formula (7) is the one to use in all cases where the value of RD_1 is enough larger than RD to cause serious error. The error in Barlow's formula increases as the internal radius decreases, and for thick pipes where the diameter is small, the more exact formulas of Lami and others should be used. (See Merriman's "Treatise on the Mechanics of Materials.")

ART. 26. Riveted Joints.

In the determination of simple stress, such as tension, compression and shear, the formula $S = \frac{P}{A}$ always gives the relation between the force P and the unit stress S . The area A must always be the area over which the stress is induced, and will, for tensile or compressive stresses, be a section of the bar perpendicular to the line of action of the force P , and parallel to the same line for shearing stresses. If the area of the section of the bar varies for different cutting planes, the plane that gives the least area should always be chosen.

When two plates are joined together by means of rivets, the joint is called a *Riveted Joint*.

ART. 27. Tension in the Plates.

Let A and B (Fig. 27 *a*) be two plates joined together by means of rivets passing through the cover plates a and b . Let P be the tensile force tending to separate the plates

A and B , w the width of the plates, t the thickness of the plates A and B , t_1 the thickness of the plates a and b , and d the diameters of the rivets.

Since P is a tensile force, and the greatest number of rivets in line is two, if we pass a plane perpendicular to the line of action of the force P through the line of the two rivets, cutting either of the plates A or B ,

or the cover plates a and b , the stress which acts in such a plane to resist separation is the product of the unit stress induced and the area cut.

The area cut by the plane is either the thickness of the two cover plates a and b times the width of the plates less the diameters of the rivets in line, or the thickness of the plates A or B into the same quantity. Hence the relation between the tensile force P and the unit stress induced in the plates is, $2t_1(w - 2d)S_t = P$, or $t(w - 2d)S_t = P$, depending on whether the failure is in the plates A or B or the cover plates a and b .

As there is no reason why one of these sections should be stronger than the other, $2t_1$ is generally made equal to t . Since any other cutting plane would cut a larger area, the value of S as given in the above formula is the largest

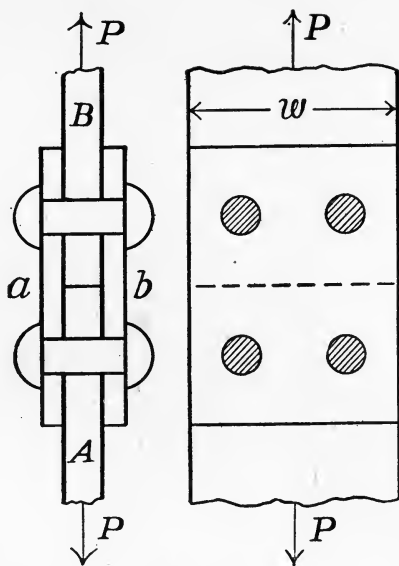

FIG. 27 a.

value possible with the force P . Figure 27 *b* shows the failure by tension in the plates.

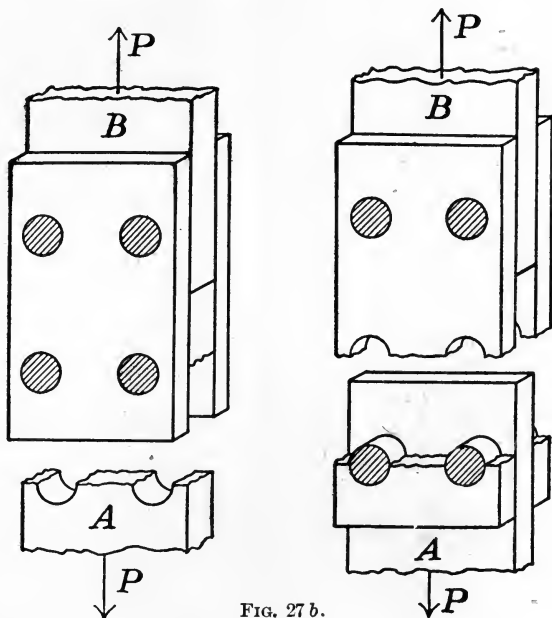

FIG. 27 *b*.

ART. 28. Shear on the Rivets.

If the plates do not yield in tension, in order to pull the plate A away from B , and the cover plates, the number of rivets passing through A must be sheared off in two sections parallel to the line of action of the force P , and perpendicular to the axis of the rivets. Therefore the area to resist shear on the rivets caused by the force P must be twice the sectional area of each rivet times the number of rivets passing through the plate A . These values substituted in the general formula, $P = AS$ give for this joint, $2 \times \frac{2\pi d^2}{4} S_s = P$. (See Fig. 28.)

ART. 29. Compression on the Rivets or Plates.

Suppose that the plates resisted the tensile stress, and that the rivets, the shearing stress, the force P acting on A , causes the plates to bear on the cylindrical surface of the rivets. The exact effective area of each rivet, or the plate through which it passes, is not known; but it is assumed to be the projected area of the rivet; that is, the

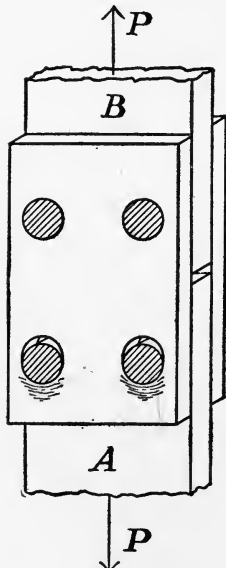

FIG. 29.

diameter of the rivet times the thickness of the plate through which it passes. On this assumption, taking $2t_1 = t$, the area to resist compression on each rivet is dt . This area times the number of rivets passing through A , when substituted in the general formula, $P = AS$, gives for this joint,

$$2 dtS_c = P_c,$$

as the relation between the force P and the unit compressive stress on the rivets or plates. (See Fig. 29.)

As there is no other way that the joint can fail, the equation that gives the least value of P determines the way in which the joint is most liable to fail.

ART. 30. General Case of Riveted Joint.

In general, while the joint may be very long, the rivets are regularly spaced. In this case, the distance between

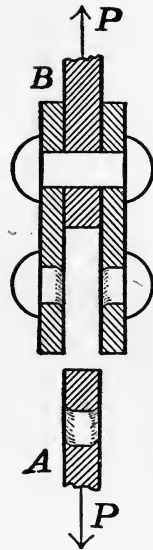

FIG. 28.

the centers of any two rivets in line is called the "pitch" of the rivets, and P is taken as that proportion of the load on the entire joint that the pitch is of the length; or in other words, P is the load or force on the joint for a distance equal to the pitch of the rivets.

Tension in the Plates.

Taking P as above, and letting p be the pitch of the rivets, the relation between the tensile unit stress in the solid plate and the force P is,

$$tpS_t = P, \quad (1)$$

where, if S is the safe unit stress, P is the safe load.

For all joints in tension, since there can never be but one rivet in line in the distance p ,

$$t(p - d)S_t = P_t. \quad (2)$$

If, as before, S_t is the safe tensile unit stress, P_t is the safe load when failure is considered as taking place by tension in the punched plates. If the values of S_t are the same in (1) and (2), it is easily seen that P_t can never equal P .

Shear on the Rivets.

The relation between the load P and the unit shearing stresses will depend on the nature of the joint. In any given case, the product of the number of times each rivet may shear, the number of rivets in the distance p , and the area of the section of the rivet perpendicular to its axis, will be the area over which the shearing stresses act. Letting c be the number of rivets times the number of sections in the distance p , then

$$\frac{\pi}{4} cd^2 S_s = P_s. \quad (3)$$

When safety of the joint against failure by the shearing of the rivets is considered, if S_s is the safe unit shearing stress, then P_s is the safe load.

Considering (2) and (3), the values of p and d can be chosen so that when safe values of the unit stresses S_t and S_s are used, $P_t = P_s$, but they are not necessarily equal.

Compression on the Rivets or Plates.

Taking S_c as the safe unit stress in compression, and td times the number of rivets in the distance p as the area resisting compression, and letting c_1 be the number of rivets,

$$c_1 t d S_c = P_c \quad (4)$$

is the relation between the unit stress in compression and the load P_c . As before, P_c may have different values from either P_t or P_s , but if they are assumed to be equal, and safe values of S_t , S_s , and S_c are used in equations (2), (3), (4), as there are three equations and three variable quantities, p , t , and d can always be determined.

If the values of p , t , and d are found in this manner, the joint will be equally safe against failure in all ways. In general, the equation which gives the least value of P will show the way in which failure is most liable to occur.

ART. 31. Kinds of Riveted Joints.

Lap Joints. Here the two plates to be joined together lap by each other and the rivets pass through both plates. The rivets tend to shear on but one section, and are said to be in "single shear."

Butt Joints with Single Cover Plates. Here the plates are both in the same plane, and the joint between them is covered by a plate of the same thickness as the plates. Any rivet passes through the cover plate and one of the

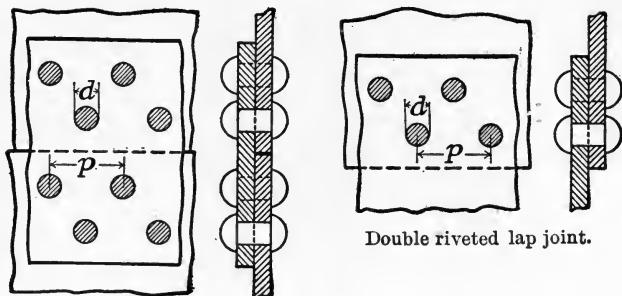

Double riveted butt joint with single cover plate.

Double riveted lap joint.

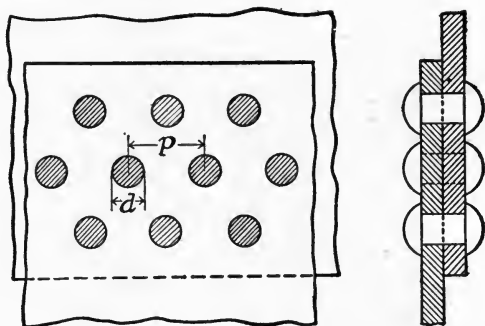

Triple riveted lap joint.

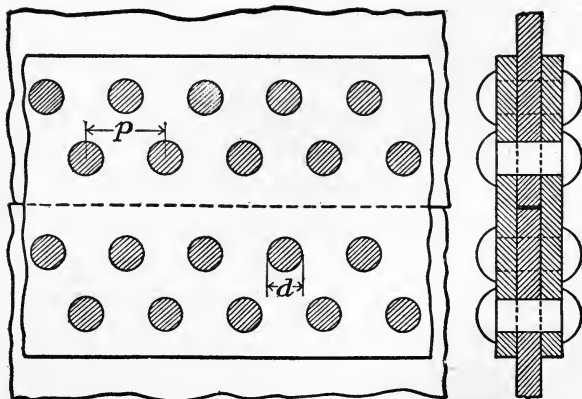

Double riveted butt joint with double cover plates.

FIG. 31.

plates that are to be joined together. The conditions for shear and compression are evidently the same as for lap joints.

Butt Joints with Double Cover Plates. In this kind of a joint the plates are in the same plane, and the cover plates, each one half the thickness of the plates to be joined, are placed on either side of the joint. Any rivet passes through both cover plates and one of the plates that are to be joined.

An inspection of the figure will show that each rivet is liable to be sheared in two sections and is said to be in "double shear," while the conditions for compression are the same as for the one with single cover plates.

Either type of a joint may have one or more rows of rivets, and the pitch in all rows is generally the same. The joint is said to be *Single*, *Double*, or *Triple* riveted, as there are one, two, or three rows of rivets. The figures show the details of the various joints and styles of riveting. It is evident that if lines are drawn passing through any two adjacent rivets in the same row, and parallel to the line of action of P , the rivets included between these lines will be the number of rivets that are to be considered as resisting the shear and compression.

ART. 32. Efficiency of a Riveted Joint.

When P_t , P_s , and P_c are the maximum safe loads a riveted joint will carry, the efficiency of that joint may be defined as the ratio of the least of the above values, to the load the unpunched plate of the same length will carry under the same conditions.

From this definition it is evident that the efficiency of any joint is P_t , P_s , or P_c , divided by P , depending on the

relative values of P_t , P_s , and P_c . Of all the ways in which a riveted joint may fail, the failure by compression of the rivets or plates is the least understood, and many engineers design the joint for equal strength in tension and shear, and simply check the resulting dimensions for the compressive stress. This practice has resulted in the efficiency of a riveted joint being given as $\frac{p-d}{p}$, but this is only approximately true unless $P_t = P_s = P_c$.

In general, when the values of t and d are calculated, the nearest commercial sizes have to be chosen, and the values of P_t , P_s , and P_c are rarely ever equal.

In many cases the pitch is fixed by the conditions for the tightness of the joint against leakage, as for boilers, tanks, and pipes, and in such cases only two conditions can be satisfied.

In the development of the preceding formula no account has been taken of the friction that must exist between the plates through which the rivets must pass.

As there is no good theoretical way of introducing the resistances due to friction in the formulas for strength, riveted joints have been pulled apart in testing machines, and the accuracy of the formulas checked by the breaking load as determined by the test. While the results in many cases seem to show that the theory that has been given here does not hold true, the conditions that are concurrent with the rupturing load not being the same as when all the stresses are within the elastic limit, there seems to be no good reason why the formulas as developed will not give reliable results.

In the design of a riveted joint for a pipe or a boiler to carry a pressure of R lb./sq. in., as one half of the

internal pressure tending to disrupt the pipe or boiler is carried on one joint of the shell the value of P to be used in the formulas is one half of the total pressure acting over a length p , or, $\frac{R D p}{2} = P$.

ART. 33. Stresses Due to Change of Temperature.

All metals tend to change in length as their temperature changes. If the change is resisted, that resistance must cause a stress in the material.

Consider a bar l units in length, A units in area, free to change its length as the temperature changes. If the change in length due to a given change of temperature is e , and a force is exerted to restore the bar to its original length, the unit stress induced by that force will be given by

$$E = \frac{Sl}{e}.$$

Therefore if a force prevents the change from taking place, it must induce an equal unit stress, and this unit stress is independent of the area of the bar. Knowing the change in unit of length for a change of 1° of temperature, or the coefficient of linear expansion, the unit stress in any bar corresponding to any change of temperature may be found provided the unit stress is within the elastic limit of the material.

If the bar is under an initial unit stress before the change of temperature, the change will increase or decrease that stress, depending on the nature of the initial and temperature stresses.

PROBLEMS

1. How long will a bar of wood have to be, in order that its own weight will produce a unit stress of 300 lb./sq. in.? The bar is hanging vertically.

SOLUTION. Taking the weight of a bar of wood, 1 sq. in. in section and 3 ft. long, as $\frac{1}{2}$ lb., the bar will have to be as long as 300 divided by $\frac{1}{2}$, equal 360 yd. *Ans.*

2. What is the length of a vertical steel bar a square inch in area, that carries a tensile load of 4000 lb., at the lower end when the maximum unit stress is 15,000 lb./sq. in.?

3. Find the probable elongation in problem 1.

SOLUTION. Since the maximum unit stress is 300 lb./sq. in. and the minimum 0, the average unit stress must be 150 lb./sq. in., and we have given that $E = \frac{Sl}{e}$,

$$1,500,000 = \frac{150 \times 360 \times 36}{e} \quad \therefore e = 1.296 \text{ in.}$$

4. Find the total elongation in problem 2.

(Total elongation is that due to the load and its own weight.)

5. Find the height of a brick chimney of uniform section, when the maximum compressive unit stress is 18 tons/sq. ft.

6. Suppose that the sectional area of the base of a chimney was twice that at the top, and that the change in area was uniform, how high could the chimney be built if the limiting value of the unit stress was 18 tons/sq. ft.?

7. Find the areas of the top and bottom section of a stone pier, 100 ft. high, to carry a load of 240 tons, the unit stress in all sections to be constant.

8. If the pier in problem 7 had the top and bottom areas as found and the vertical section was trapezoidal, find the unit stress at the bottom of the pier.

9. The wire rope used for hoisting in a certain mine is $1\frac{1}{4}$ in. in diameter, and weighs 2.5 lb./ft. If the mine is 800 ft. deep and the safe working load for the rope is $5\frac{1}{2}$ tons, what weight may be raised?

10. A pipe 6 in. in diameter is to carry water under a pressure of 1000 lb./sq. in., with a factor of safety of 6; required the thickness of the pipe walls.

11. A standard 2-inch steel pipe is 2.375 in. outside diameter and 2.067 inside. This size is tested under a pressure of 500 lb./sq. in.; required the unit stress in the pipe walls.

12. A steel pipe 10 in. in diameter is to carry water under 2770 ft. head. The factor of safety is to be 10. Find the thickness of the pipe.

(A column of water 1 ft. high and 1 sq. in. in area weighs .434 lb.)

13. Check the results in problem 12 by Barlow's formula and find the unit stress.

14. Compare the maximum unit stress in the pipe of problem 11, as determined by the formulas for thick and thin pipes.

15. Write the formulas for determining the strength of the following riveted joints in tension, compression, and shear. The pitch is p , the thickness of the plates t , diameter of the rivets d , and the safe unit stresses in tension, compression, and shear are S_t , S_c , and S_s .

- (a) Single riveted lap joint.
- (b) Double riveted lap joint.
- (c) Single riveted butt joint with one cover plate.
- (d) Double riveted butt joint with one cover plate.
- (e) Single riveted butt joint with two cover plates.
- (f) Double riveted butt joint with two cover plates.
- (g) Triple riveted butt joint with two cover plates.

SOLUTION FOR (a).

If P_t is a tensile force acting on the joint for a distance equal to the pitch, then since $P = AS$, and the area to resist the tensile stress is $t(p - d)$, $P_t = t(p - d)S_t$ gives the relation between the load and the unit tensile stress.

Let P_c be the tensile force that brings compression on the rivets. As there is but one rivet in the distance p , the area to resist compression is td , and since $P = AS$, $P_c = tdS_c$ is the relation between the load and the compressive unit stress, and if P_s is the tensile force that produces shear on the rivets, as there is only one rivet in the distance p , and it can shear in but one section, as $P = AS$, $P_s = \frac{\pi d^2}{4} S_s$ is the relation between the load and the unit stress in shear.

16. If the values of P_t , P_c , and P_s , in each of the different joints given in problem 15 are taken as being equal, find the expressions for the values of p and d , in terms of t , and the efficiency of each joint.

SOLUTION FOR (a).
$$tdS_c = \frac{\pi d^2}{4} S_s,$$

$$d = \frac{4 S_c t}{\pi S_s},$$

and

$$t(p - d)S_t = tdS_c,$$

$$p = \frac{d(S_t + S_c)}{S_t}.$$

Substituting the value of d ,

$$p = \frac{4 S_c t(S_c + S_t)}{\pi S_s S_t},$$

and since the expression for the efficiency when the strength of the joint is equal against all kinds of stress is $\frac{p - d}{p}$, substituting for these their values as found, their efficiency is $\frac{S_c}{S_c + S_t}$.

17. A steam boiler, 60 in. in diameter, carrying 120 lb./sq. in., is to have the longitudinal seams double riveted butt joints with two cover plates. Take $S_t = 12,000$ lb./sq. in., $S_s = 10,000$ lb./sq. in., and make the joint equally safe against failure by either tension or shear. If

the efficiency is to be either approximately 75 %, required the thickness of the plates, the diameter, and pitch of the rivets.

SOLUTION. The thickness of the plate is given by $RD = .75 \cdot 2 St$ as the unit stress in the unpunched part of the plates can be only 75% of the allowable unit stress, or,

$$120 \times 60 = .75 \times 2 \times 12,000 t$$

$$t = \frac{120 \times 60}{.75 \times 2 \times 12,000} = 0.4,$$

and the expression for the efficiency in tension being efficiency

$$\frac{p-d}{p} = .75,$$

$$p = 4d.$$

Take $\frac{7}{16}$ as the nearest market size for the required thickness of the plate, for equal strength,

$$t(p-d)S_t = 2 \times 2 \times \frac{\pi d^2}{4} S_s,$$

$$\frac{7}{16} (4d-d)12,000 = \pi d^2 \times 10,000,$$

$$d = \frac{1}{2}'' \text{ approximately;}$$

then

$$t = \frac{7}{16}'' , d = \frac{1}{2}'' , \text{ and } p = 2''.$$

18. In problem 17, taking the values p , t , and d as found, what must be the value of the unit stress in compression, in order that the joint will be equally safe against failure by tension, compression, or shear?

19. A boiler, 30 in. in diameter, has double riveted lap joints, plates $\frac{1}{2}$ in. thick, rivets $\frac{7}{8}$ in. diameter, pitch of the rivets 2.5 in. Taking S_t as 60,000 lb./sq. in., find the pressure per square inch that may be carried with a factor of safety of 6, considering failure by tension of the plates alone.

20. What are the values of S_t and S_c , and the efficiency of the joint, in problem 19?

21. A triple riveted butt joint with two equal cover plates is to have an efficiency of 80 %. Using $S_t = 10,000$

lb./sq. in. as the safe unit stress in tension, what will be the values of S_c and S_s , when the joint is equally safe against failure by tension, compression, or shear?

22. If S_t is taken as 10,000 lb./sq. in., and S_c as 15,000 lb./sq. in., what is the highest possible efficiency of a double riveted lap joint, designed for equal strength against tension, compression, and shear?

23. A steam boiler with double riveted lap joints is to carry 125 lb./sq. in. pressure. The allowable tensile unit stress is 10,000 lb./sq. in. The plates are $\frac{5}{8}$ in. thick, rivets 1 in. diameter, and the pitch $3\frac{1}{2}$ in. What will be the largest possible diameter of the boiler?

24. Compare the values of S_t , S_s , and S_c in problem 23.

25. A 30-foot steel railroad rail undergoes a change of temperature of 100° . If the change in length is prevented, what unit stress will be set up in the rail?

SOLUTION. The coefficient of linear expansion for steel is .0000065 per degree; hence the unit elongation for 100° is .00065 in., and since

$$S = E\epsilon,$$

$$S = 30,000,000 \times .00065 = 19,500 \text{ lb./sq. in.}$$

26. For electric railway work, the steel rails are often welded together. Assuming that there is no change of length, what is the maximum range of temperature allowable if the unit stress is not to be greater than the elastic limit?

27. The walls of a building had bulged out, and to pull them into place, five steel rods each two sq. in. in area were passed through from one wall to the other. The temperature was then raised 100° and the nuts on the rods tightened, so that the load on each bolt was 1000 lb. When the rods are at the original temperature, what is the maximum pull they could exert on the walls?

28. At St. Louis, Mo., a battery of steam boilers was connected together by a pipe in which there was no provision made for expansion. The temperature of the steam was about 360° F. and that of the room, 100° . Assuming that there was no change in length, what was the maximum unit stress in the pipe due to the change of temperature?

- (a) Material of the pipe steel?
- (b) Material of the pipe cast iron?

CHAPTER III

BEAMS

ART. 34. Kinds of Beams.

When a bar is placed in a horizontal position, and acted on by forces perpendicular to the axis of the bar, it is called a *Beam*.

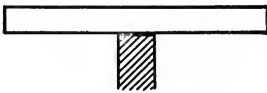

Cantilever Beam.
FIG. 34 a.

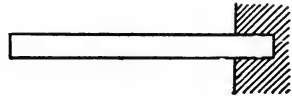

Cantilever Beam.
FIG. 34 b.

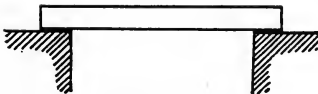

Simple Beam.
FIG. 34 c.

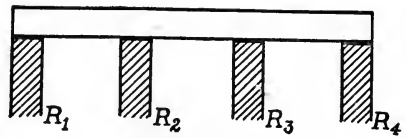

Continuous Beam.
FIG. 34 d.

If the beam has two supports on which it merely rests, it is called a *Simple Beam*.

A cantilever beam has only one support, which is at the middle, or, what is the same thing, has one end firmly fixed in the wall, leaving the other end free.

When a beam has both ends firmly fixed in the walls, or one end fixed and the other merely supported, it is called a *Fixed* or *Restrained Beam*.

A beam supported at more than two places is called a *Continuous Beam*.

ART. 35. Reactions at the Supports.

The reactions at the supports are the forces acting between the supporting walls and the beam, and so far as the beam is concerned, they may be treated as vertical forces acting upward.

ART. 36. Uniform and Concentrated Loads.

The loads on a beam are the weights that the beam carries, and since the attraction of gravity always acts downward, they may be represented as vertical forces. When the load is distributed uniformly over the entire length of the beam so that each element of the length of the beam carries the same load, the load is said to be a *Uniform Load*.

When a load is carried on so small a portion of the length of the beam that the effect of the weight acting as it does over that small portion may be assumed to have the same effect as a single force acting at the center of the load, it is called a *Concentrated Load*.

Since a simple or cantilever beam under any loads may be considered as a body acted on by forces which keep it at rest, the laws relating to the equilibrium of forces must be satisfied.

In general, all the forces, loads and reactions, will be vertical, and the magnitude and position of the loads will be known, so that the magnitude of the reactions may be determined by applying the laws relating to the equilibrium of parallel forces.

These laws are:

The algebraic sum of all the forces equals zero, and the algebraic sum of the moments of all the forces about any point equals zero.

These two equations are sufficient to determine the reactions for simple and cantilever beams, as there are not more than two quantities to be determined.

For all other beams another condition is derived by the use of the theory of the *Elastic Curve*. (See Chapter IV.)

The length of a simple beam is the distance between the supporting walls and the distance the beam projects beyond the wall for a cantilever beam.

While in any case the beam must rest on the supporting wall for a finite distance, the point of application of the single force that is to replace the resultant of the forces acting between the beam and the wall is taken at the edge of the wall beyond which the beam projects.

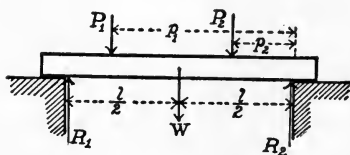

FIG. 36.

Let Fig. 36 represent a simple beam, length l , weight W , carrying two concentrated loads P_1 and P_2 at distances p_1 and p_2 from the right reaction,

and the values of the reactions R_1 and R_2 are required.

The weight W may be considered as a uniform load, and for equilibrium,

$$R_1 + R_2 - P_1 - P_2 - W = 0. \quad (1)$$

Taking moments about a point in the line of action of R_2 , and giving the moment a positive sign when it tends to produce clockwise rotation,

$$R_1 l + R_2 0 - P_1 p_1 - P_2 p_2 - \frac{Wl}{2} = 0. \quad (2)$$

The term containing R_2 is zero, therefore R_1 may be found, and by substituting for R_1 in equation (1), R_2 may also be determined.

R_2 may also be found by taking moments about a point in the line of action of R_1 , and this value used as a check.

If the weight of the beam, W , included both the weight of the beam and a uniform load, the equations would have been the same.

ART. 37. Vertical Shear.

Let Fig. 37 *a* represent a simple beam, loaded with both uniform and concentrated loads, and Fig. 37 *b* a cantilever beam with the same loading.

Suppose either beam to be cut by a plane $X-X$ perpendicular to the axis of the beam, at any distance x from the

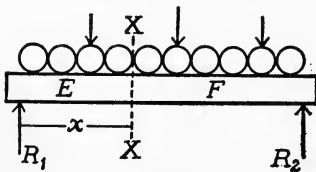

FIG. 37 *a*.

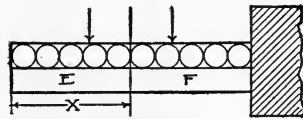

FIG. 37 *b*.

left end of the beam, and consider the end marked E . This end is acted on by known forces, since, when the loads are known, the reactions can be found, and relative to the end marked F , these forces tend to produce translation either up or down, the magnitude of the resultant force being the algebraic sum of all the forces acting on the part E .

Similarly, considering the part marked F , the resultant of all the forces acting on F tends to produce translation relative to E , and these two resultants being equivalent to all the forces acting on the beam, must be equal and opposite in sign, since the beam is in equilibrium.

These two resultants are a pair of shearing forces, and either one is the force producing shear in the plane $X-X$, and if we wish to call one of these forces the *Vertical*

Shear at the section $X-X$, it will be necessary to define vertical shear so that the sign will be determined as well as the magnitude.

The vertical shear at any section of a beam is defined as follows:

The *Vertical Shear* for any section of a beam is the algebraic sum of all the forces acting on that portion of the beam, lying to the left of that section.

When the resultant force acts upward, the vertical shear is considered positive, and negative when it acts downward.

ART. 38. Bending Moment.

If we take the sum of the moments of all the forces that act on the right and also those that act to the left of the section $X-X$ (Figs. 37 *a* and 37 *b*) about a point in that section, the resulting moments must be equal and opposite in sign, and as either is a measure of the tendency of rotation to take place about a point in the plane $X-X$, they are the bending moments for that section.

In order to fully determine the bending moment both as to sign and magnitude, it is defined as follows:

The *Bending Moment* at any section of a beam is the algebraic sum of the moments of all the forces, acting on that portion of the beam lying to the left of the section, moments being taken about a point in that section.*

It is considered positive when the moment tends to produce clockwise motion and negative for counterclockwise motion. The "section of the beam" as used in the definition of both vertical shear and bending moment

* A cantilever beam is always considered as being fixed at the right end, leaving the left end free. If the beam projects toward the right, look at it from the other side.

refers to any plane section perpendicular to the axis of the beam, and the "forces acting to the left of the section" includes both the loads and reactions whose points of application are on the left of the section.

ART. 39. Resisting Shear.

Since the part of the beam on the left of the section $X-X$ (Figs. 37 *a* and 37 *b*) is acted on by external forces, and as a part of the whole beam it is in equilibrium, there must be internal forces acting in the section $X-X$, which taken with the external forces acting to the left of the section, constitute a system of forces in equilibrium. Suppose these unknown forces to be resolved into their horizontal and vertical components. Then, since equilibrium exists, the algebraic sum of the vertical components of the internal forces must equal the sum of the vertical forces, and since the external forces have no horizontal components, the sum of the horizontal components of the internal forces must be zero, and also, the algebraic sum of the moments of the external forces must equal the sum of the moments of the internal forces, moments being taken about a point in the section $X-X$.

From the first condition, if we give the name of *Resisting Shear* to the sum of the vertical components of the internal forces,

The Vertical Shear = the Resisting Shear,

and assuming the shearing forces to be uniformly distributed over the area of the section, then

$$V = AS, \quad (3)$$

where A is the area of the section and S is the unit shearing stress, and V the vertical shear for the section.

ART. 40. Resisting Moment.

From the second condition, since the horizontal components of the internal forces must be either tensile or compressive forces, the sum of the tensile Forces = the sum of the compressive Forces.

Giving the name of *Resisting Moment* to the moments of the internal forces about a point in the section, the third condition for equilibrium states that,

The Bending Moment = the Resisting Moment.

The relation between the bending moment of the external forces and the unit stresses in the section considered, cannot be found by the laws of mechanics alone, as the distribution of the internal forces is unknown. The information necessary may be derived from the results of experimental observations on beams while under the action of bending forces.

When a beam is under the action of bending forces, it is observed that along the concave surface of the beam the fibers* of the beam are shortened, while those on the convex surface are lengthened, and that along a certain plane section of the beam there is no change in length.

We know that a compressive force shortens, and that a tensile force lengthens, any bar on which it acts, and that where there is no deformation there can be no force acting; therefore the stress on the concave surface must be compression, and that on the convex surface, a tensile

* The word "fiber" as used here may be defined as a bar of elementary sectional area and a length equal to that of the beam, the whole beam being composed of a bundle of such fibers. It is not necessary that the beam should be of a fibrous material in order that this conception should be true.

stress, while at the certain plane, called the *Neutral Surface*, there is no stress of any kind.

When the loads were such that there was no unit stress greater than the elastic limit, it was observed that the deformation of any fiber was proportional to its distance from the neutral surface.

If we call the trace of this neutral plane on any plane section of the beam perpendicular to the axis, the *Neutral Axis* of the section, since there is no unit stress greater than the elastic limit, it is evident that the unit stress at any point in that section, and consequently the forces producing that unit stress, must vary directly as the distance from the neutral axis. This assumes that E is constant, since $E = \frac{Sl}{e}$, and when the location of the axis is known, the unit stress at any point may be found.

Let Fig. 40 represent any cross section perpendicular to the axis of the beam, and the line $X-X$ the neutral axis. From the experimental observations we know that the greatest unit stress must be at the greatest distance from the neutral axis; and letting c be the distance from the neutral axis to the fiber most distant from that axis, A the area of the section, dA the area of any fiber, y the distance of that fiber from the neutral axis, and S the unit stress at a distance c from the neutral axis, then since the force varies as the distance from this neutral axis, the force at any distance y , acting on the area of any elementary fiber dA is $\frac{S}{c}y dA$, and $\frac{S}{c} \int y dA$ is the summation of the horizontal forces acting on the whole section.

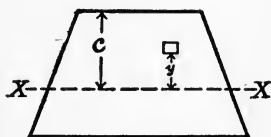

FIG. 40.

From the conditions of the problem, this sum is equal to zero, and as neither S or c can be zero, $\int y dA$ must be zero.

If we assume the density to be constant, this is the condition where the axis of moments passes through the center of gravity of the section; hence the neutral axis passes through the center of gravity of the section. The force on any fiber being $\frac{S}{c} y dA$, the moment of this force about the neutral axis is $\frac{S}{c} y^2 dA$, and the sum of the moments of these forces about a point in the section is $\frac{S}{c} \int y^2 dA$, which is the *Resisting Moment* by definition. The $\int y^2 dA$ is defined in mechanics as the moment of inertia of the section about a gravity axis, and is represented by the symbol I .

Therefore, since the Bending Moment = the Resisting Moment,

$$M = \frac{SI}{c} \quad (d)$$

In this formula M is the bending moment of the external forces that act on the left of any section, I the moment of inertia of the section about a gravity axis perpendicular to the direction of bending, c the greatest distance of any fiber from the neutral axis, while S is the maximum unit stress in that section.—

The formula expresses the relation between the bending moment and the unit stress in the section, and if the maximum unit stress in a beam is desired, M must be the maximum bending moment for that beam under the given loads.

As an aid to memory, attention is called to the similarity between this expression and the one derived for axial stress.

P and M are the external forces, S in each case is the unit stress induced; and as $\frac{I}{c}$ depends on the shape and area of the section for its value, it may be considered as replacing A in the formula for axial stress.

ART. 41. Use of Formula.

In the derivation of the formula for axial stress, there was no consideration taken of the intensity of the stress or of the nature of the material, the formula holding true for all unit stresses and materials. When the formula

$S = \frac{Mc}{I}$ was derived, certain conditions were specified.

They are:

(1) The material was to be elastic, and since we assumed that the forces were proportional to the deformations, the modulus of elasticity must also be constant.

(2) In order for $\int y^2 dA$ to be the sum of the moments of the differential areas about the gravity axis, the material of the beam must have a uniform density.

(3) No unit stress to be greater than the elastic limit.

If the material and loading of a beam does not satisfy these three conditions, the formula $S = \frac{Mc}{I}$ will not give the true unit stresses.

The *Modulus of Rupture* is the value of S as derived from $S = \frac{Mc}{I}$, when M is large enough to rupture the beam. Since the formula only holds true for unit stresses within the elastic limit, the value of the modulus of rup-

ture as an engineering constant is at least doubtful. In testing cast iron bars in bending, the breaking load at the center, which is of course proportional to the modulus of rupture, is taken as a measure of the quality of the material. The results of such tests are useful for comparison only when the tests are made on bars of the same length and size.

The formula $S = \frac{Mc}{I}$, expressing as it does the relation between the bending moment and the unit stress in a beam, is used in all calculations for the strength, safety, and design of beams. When sufficient data are given to fully determine the value of M , the value of either S or $\frac{I}{c}$ may be found.

The value of $\frac{I}{c}$ depends on the form and area of the section, and is called the *Section Modulus*.

In the application of the formula $S = \frac{Mc}{I}$ to any given case, the question of units becomes one of great importance.

It does not make any difference in the effect of M , whether it is expressed in inch pounds, or foot pounds; but as S is the unit stress and is usually given in pounds/square inch, the value of M must be expressed in inch pounds and c and I in inches, in order to get correct results.

The ton could just as well be used as the unit of weight and the foot as a unit of length, but such practice would require a special table of the constants of materials, the one given in the Appendix being based on the pound and inch.

As there are many different sections that have the same section modulus, the designer is called on to choose a form of section best suited to the conditions that exist in the case in hand.

The value of I for a rectangular section, breadth b , and depth d , about an axis through the center of gravity parallel to the side b , is $\frac{bd^3}{12}$, and c is $\frac{d}{2}$.

Substituting these values in the general formula $S = \frac{Mc}{I}$ gives the value of M as $\frac{Sbd^2}{6}$.

Therefore, when the section is rectangular we see that the value of M for any given value of S increases directly as b and as d^2 , and any increase in the value of d increases the strength more than a proportional increase in the value of b , while the weight of the beam will be the same for either case.

A practical limit of the ratio of $\frac{d}{b}$ is about 6.

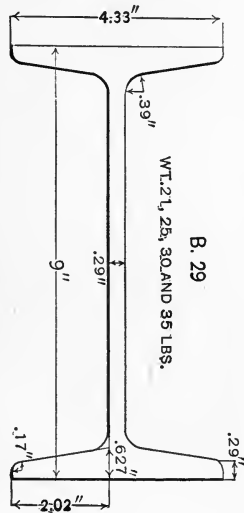

FIG. 41 a.

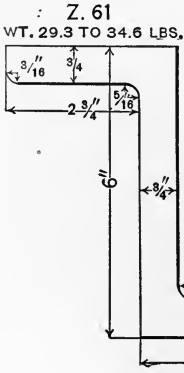

FIG. 41 b.

From the known condition that the unit stress in any point in the section varies as the distance from the neutral axis, it is evident that the form of section which presents the greatest area where the unit stresses are large and a minimum area where they are small will be the best from an economic standpoint.

The common steel I beam, so called from the form of the section, is an example of this distribution of area. There

is always a maximum vertical shear to be resisted in all beams, and care should be taken that the area of the section chosen is large enough to resist the shearing forces. In most cases if the beam is safe against the bending forces, it will be safe against the shearing forces, but the unit shearing stress should always be investigated before the final decision is made as to

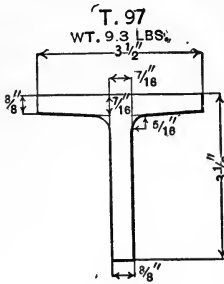

FIG. 41 c.

the size of a beam.

The hollow box or cored sections in cast iron machine parts subjected to bending forces represent the best practice on account of the large value of I relative to the weight.



Plate Girder.

FIG. 41 e.

Plate girders, made by riveting angle irons to a steel plate called the web, making a beam whose section resembles that of the common I beam, are in common use in structural steel construction.

the shearing forces. In most cases if the beam is safe against the bending forces, it will be safe against the shearing forces, but the unit shearing stress should always be investigated before the final decision is made as to

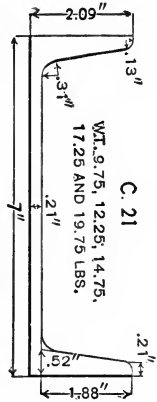

FIG. 41 d.

Plate girders, made by riveting angle irons to a steel plate called the web, making a beam whose section resembles that of the common I beam, are in common use in structural steel construction.

ART. 42. Shear and Moment Diagrams.

If a line which may be either straight, curved, or broken be drawn so that the ordinate to that line from any point of a straight line representing the length of the beam equals the vertical shear or bending moment for that section of the beam, the resulting diagram is called a *Shear* or *Moment Diagram*, depending on whether the vertical shears or the bending moments are used as ordinates.*

* This line will be called the shear or moment line.

To draw either diagram, the shears or moments for each unit of length of the beam might be calculated and the results plotted to scale, using as ordinates the values of the moments or shears and as abscissa the distances of the sections from the left end of the beam. A line through the points so located would be the shear or moment line, as the case might be.

This is a tedious process and may be shortened by a study of the effect of the different kinds of loads on the form of the shear or moment line.

ART. 43. Shear Diagram.

For a concentrated load, the difference between the shears for sections taken just to the right and left of the point of application of the load is the magnitude of that load, since in the former case the "negative forces acting to the left of the section" are increased by the magnitude of the load over those for a section taken just to the left of the load. Therefore, the shear line will always contain a line perpendicular to the length of the beam under each concentrated load.

When only concentrated loads are considered, the shear line between any two concentrated loads will be a straight line parallel to the length of the beam, since there is no change in the forces acting to the left of any section taken between the two loads.

For uniform loads of w pounds per linear unit, the shear line will be a straight line inclined toward the right, as the resultant force on the beam due to the uniform load is decreased by wx , where x is the distance of the section from the left end.

If there are concentrated loads as well as uniform loads,

the shear line will be straight and vertical under the loads and inclined between the concentrated loads.

To apply these principles, let Fig. 43 represent a simple beam, carrying two concentrated loads, P_1 and P_2 , and a uniform load of w pounds per linear unit.

Remembering the definition of vertical shear, it is easily noted that the shear at the left end is equal to the left reaction R_1 which is plotted as AO . The shear between the left end and P_1 is $R_1 - wx$, where x is the distance of the section considered from the left end.

For a section distant p_1 from the left end, taken just to the left of P_1 , the shear is less than the shear to the left end by wp_1 , and the ordinate to the line AB at any

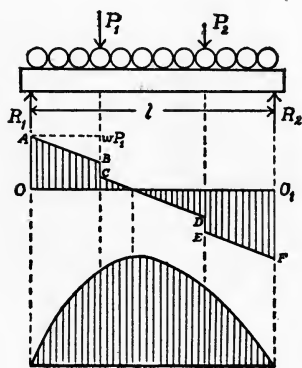

FIG. 43.

point will be the vertical shear for that section. For a section just to the right of P_1 , the equation of the shear has become $R_1 - wx - P_1$, as the two sections taken to the right and left of P_1 are considered so close together that the uniform load has not increased. The shear line will therefore drop to C on a vertical line through the point of application of P_1 .

Between P_1 and P_2 the shear will decrease at the same rate as between R_1 and P_1 , since the load increases directly as the distance and CD will be parallel to AB . Then comes the drop due to P_2 , and EF is parallel to AB and CD . FO must be the value of the right reaction, since the sum of the vertical forces must be equal to zero.

It is evident that the consideration of more concen-

trated loads would simply extend the diagram in a similar manner, and also, if the magnitude of the uniform load per unit of length should change at any point, the inclination of the shear line would also change at the same point.

ART. 44. Moment Diagrams.

The general equation of the bending moment for any section of a beam may be written from its definition. For a section of a beam distant x from the left end, the moment of the left reaction R_1 about a point in that section is R_1x , and the moment of the uniform load on the left of the section about a point in that section is the arm $\frac{x}{2}$ times $w x$, or $\frac{w x^2}{2}$, hence,

$$M = R_1x - \frac{w x^2}{2} - \left\{ \begin{array}{l} \text{the sum of the moments of the loads} \\ \text{that act to the left of the section} \\ \text{about a point in that section.} \end{array} \right.$$

If there are no concentrated loads, the term containing the sum of the moments, etc., is zero, and for a cantilever beam the term containing the reaction R_1 is zero, since there is no left reaction.

In some cases the supports of a beam are not at the ends, and in that case the moment of the left reaction would be $R_1(x - \text{the distance of the reaction from the left end})$. When there are uniform loads on the beam, the above equation shows that M varies with x^2 , hence the moment line will be a curve.

If there are no concentrated loads, the equation of the curve will be the same at all sections, being a parabola whose equation is

$$M = R_1x - \frac{w x^2}{2}.$$

When there are concentrated loads in connection with the uniform load, the form of the equation changes at each

concentrated load, and the moment line, while still parabolic in form, has a different equation between each pair of concentrated loads.

If only concentrated loads are considered, the equation of the bending moment is

$$M = R_1x - \left\{ \begin{array}{l} \text{the sum of the moments of the loads acting} \\ \text{to the left of the section about a point in} \\ \text{that section.} \end{array} \right\}$$

If x_1 is the distance from P_1 of any section of a beam taken between any two concentrated loads P_1 and P_2 , the moment of P_1 about a point in that section is P_1x_1 . It is evident that the equation of the bending moment for any section will be changed by the addition of P_1x_1 the instant the section is taken to the right of P_1 , and as at that point x_1 is very small there will be no abrupt change in the value of the bending moment as the section passes under P_1 . As the value of M depends on the first power of x , it is evident that the form of the equation is that of a straight line.

Therefore, when only concentrated loads are considered the moment line will consist of a series of straight lines whose inclination changes at each concentrated load. If the loads are all concentrated, the bending moments may be calculated for sections under the loads and plotted to scale. Joining the points so plotted by straight lines will accurately determine the form of the moment line. If uniform loads are to be considered, the moment line between any two loads being a parabola, the bending moments for enough sections between any two loads must be found to enable the curve to be drawn (Fig. 43).

The value of M in the general equation for the bending moment is zero when x is zero, hence M is zero at the left end. The moments of all the forces about any point being

zero, M must also be zero at the right end. That this is true for simple beams is so apparent that no proof is needed. In the case of cantilever beams with the right end fixed in the wall, if we remember that such a beam is but one half of a beam supported at the middle and that the right end of such a beam is, strictly speaking, the middle, the truth of the statement is evident.

Therefore the moment diagram will be a closed figure in all cases.

ART. 45. The Relation between the Vertical Shear and the Maximum bending Moment.

Writing the general equation of the bending moment

$$M = R_1x - \frac{wx^2}{2} - P_1(x - p_1) - P_2(x - p_2) \dots - P_n(x - p_n)$$

where p_1, p_2, \dots, p_n and x , are the distances of the loads and section from the left end of the beam and the loads P_1, P_2, \dots, P_n act on the beam to the left of the section.

The value of x which makes M a maximum is the value that renders $\frac{dM}{dx} = 0$ or

$$\frac{dM}{dx} = R_1 - wx - P_1 - P_2 \dots - P_n = 0.$$

The right hand member of the last equation is the expression for the vertical shear for any section of a beam, therefore the value of x which makes the vertical shear zero renders the bending moment a maximum.

As the equation for M was a general one and will apply to all kinds of beams and loadings, the results are true for all cases.

The section of a beam where the bending moment is maximum is called the *Dangerous Section*, and the prob-

lem of finding this section is simply one of finding where the vertical shear passes through zero.

Drawing the shear diagram, if the shear passes through zero under a concentrated load, the dangerous section is determined at once. When the shear becomes zero between two concentrated loads, the general equation for the vertical shear may be written for that part of the beam and equated to zero.

The value of x which satisfies this equation determines the dangerous section.

Having found the dangerous section, the bending moment may be calculated for that section, and when this value of M is substituted in the formula $M = \frac{SI}{c}$, the value of S will be the maximum unit stress in the beam.

ART. 46. Relative Strengths of Simple and Cantilever Beams.

Let the uniform load on either kind of a beam be W and a single concentrated load at the middle of a simple beam or at the end of a cantilever beam also be W ; then if α be some number whose value depends on the kind of a beam and the way in which it is loaded, the maximum bending moment for the beam may be expressed as $\frac{Wl}{\alpha}$.

This value substituted in the general formula $M = \frac{SI}{c}$, gives $\frac{Wl}{\alpha} = \frac{SI}{c}$, which may be written $W = \frac{\alpha SI}{cl}$. The strength of a beam may be defined as the weight it will carry with a given unit stress. From the above equation for W it is evident that the weight a beam will carry with a given unit stress depends on the value of α , hence the

relative strengths of simple and cantilever beams loaded as above are directly proportional to α . If the expressions for the maximum bending moments in simple and cantilever beams loaded with W as above are written, an inspection of the results will show that for

a cantilever beam loaded with W at the end	$\alpha = 1$,
a cantilever beam loaded uniformly with W	$\alpha = 2$,
a simple beam loaded with W at the middle	$\alpha = 4$,
a simple beam loaded uniformly with W	$\alpha = 8$.

ART. 47. Overhanging Beams.

Beams that overhang the supports are called *Overhanging Beams*. The fact that the reactions do not have their points of application at the ends of the beam does not prevent the application of the laws of mechanics to the determination of the magnitude of two reactions. Consider a beam that overhangs one or both supports and loaded in any way. Taking moments about a point in the line of action of one of the reactions as R_2 , the moment of R_1 — the moments of the loads on the left of R_2 + the moment of the loads on the right of $R_2 = 0$, and as the sum of all the forces is zero, $R_1 + R_2 =$ the sum of all the loads.

These two equations will suffice to fully determine the reactions R_1 and R_2 when the magnitude and position of the loads are known.

The shear and moment diagrams can be drawn by the same principles that were applied to simple and cantilever beams.

In general, the vertical shear will pass through zero at two or more points, giving more than one value of x for which the bending moment is a maximum. The value of the bending moment at each of these points must be

calculated in order to find the greatest bending moment in the beam.

The maximum moments may be either positive or negative, but when using the greatest value of M in the formula $M = \frac{SI}{c}$, the substitution is to be made without regard to sign.

As the sign of the bending moment changes from positive to negative, its value must pass through zero, and the position of the section of a beam for which the bending moment is zero is called an *Inflection Point*. The position of an inflection point may be approximately located by an inspection of the shear or moment diagrams and the general expression for the bending moment for that part of the beam written.

Equating this expression to zero gives the position of the inflection point accurately.

ART. 48. Beams of Uniform Strength.

When the maximum unit stress in all sections of a beam is constant, the beam is said to be one of *Uniform Strength*.

The beams so far discussed have all had uniform sections, and the value of $\frac{I}{c}$ was the same for all sections.

The bending moment M varies for all sections, and if S is to be constant, $\frac{I}{c}$ must vary with M , since $M = \frac{SI}{c}$. For any beam loaded in any way the bending moment for a section at any distance from the left end may be expressed in terms of a variable distance x and this expression equated to $\frac{SI}{c}$.

Assigning different values to x , the corresponding values

of $\frac{I}{c}$ may be determined and the section of the beam at that point chosen to satisfy the value of $\frac{I}{c}$ as found above.

Beams of uniform strength may have any form of section, but they are usually made either rectangular in section or an approximation to such a section.

For beams of rectangular section $\frac{I}{c}$ equals $\frac{bd^2}{6}$ and $M = \frac{Sbd^2}{6}$, in which either b or d may be variable. Expressing M in terms of the variable distance x , the law of the variation of b or d , as the case may be, determines the shape of the beam.

At any section of the beam where $M = 0$, there is no moment to be resisted, and so far as bending is concerned the area of that section can be made zero.

In addition to the unit stress due to bending, there is at all sections of the beam a shearing unit stress due to the vertical shear at that section.

If S is the allowable unit stress in shear the area of the section where $M = 0$ is given by $A = \frac{V}{S}$, where V is the vertical shear at that section.

ART. 49. Moving Loads.

In many cases the position of the loads is not fixed, and as the loads may occupy various positions, the value of M for finding the greatest unit stress in a beam must be determined from the position of the loads which gives the greatest bending moment.

When the loads on a beam may change their positions they are called moving or *Live Loads* to distinguish them from stationary or *Dead Loads*.

Assume a beam, length l , and P_1 and P_2 two unequal loads that pass over the beam. See Fig. 49.

Let z be the distance of the greater load P_1 from the left end of the beam, and p be the distance between the two

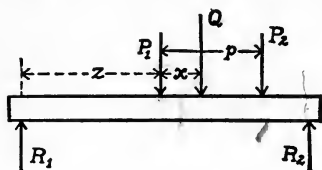

FIG. 49.

loads. The dangerous section will always occur under one of the loads, and assuming that it occurs under P_1

$$M = R_1 z.$$

Let Q be the magnitude of the resultant of P_1 and P_2 , and x be the distance of its line of action from P_1 ; then

$$P_1 x = P_2 (p - x),$$

$$x = \frac{P_2 p}{P_1 + P_2} = \frac{P_2 p}{Q}.$$

Therefore the resultant of P_1 and P_2 acts at a distance $z + \frac{P_2 p}{Q}$ from the left end of the beam.

Taking moments about a point in the line of action of the reaction R_2 ,

$$R_1 l = Q \left(l - z - \frac{P_2 p}{Q} \right),$$

$$R_1 = \frac{Q}{l} \left(l - z - \frac{P_2 p}{Q} \right),$$

and

$$R_1 z = Qz - \frac{Qz^2}{l} - \frac{P_2 p}{l} z = M.$$

M will be a maximum when

$$\frac{dM}{dz} = Q - \frac{2Qz}{l} - \frac{P_2 p}{l} = 0,$$

or

$$z = \frac{l}{2} - \frac{P_2 p}{2Q}.$$

Therefore when M is a maximum the middle of the beam is halfway between the resultant of the loads and the dangerous section of the beam.

It is evident from the form of the equations that the same results would have been obtained had there been any number of forces.

The results were obtained on the assumption that the dangerous section occurred under the first load, and if this assumption is true, the vertical shear must change sign as the section is taken to the right or left of the load P_1 .

When there are but two loads, the dangerous section always occurs under the left hand load when the two loads are equal, and under the heavier load when they are not equal.

When there are more than two loads, the position of the loads that gives the greatest bending moment does not always have the dangerous section under the maximum load, but the general law holds true that

When the middle of the beam is halfway between the resultant of the loads and the dangerous section a maximum bending moment occurs.

ART. 50. Use of Formula.

To find the position of a system of loads that causes the greatest bending moment, assume the loads to be so placed that when the dangerous section is assumed to occur under any load, the above criterion is satisfied and the vertical shear passes through zero, and calculate the bending moment for that position. The result will be the maximum bending moment that can occur and have the dangerous section under the load as assumed.

Assuming the dangerous section to occur under any other load, the maximum moment for that position may be found.

The position that gives the greatest value of M will be

the one where the greatest bending moment occurs as the loads move over the beam.

When a uniform live load moves over a beam, the greatest bending moment occurs when the load extends over the entire length of the beam. When the load only partially covers the beam, the maximum moment occurs at the dangerous section and the above criterion holds true.

The greatest vertical shear caused by any moving load is found at the supports when the resultant of the loads is nearest to that support.

ART. 51.

EXAMINATION

1. When is a bar called a beam? A simple beam? a cantilever beam? a continuous beam?
2. What is meant by, "the reactions at the supports"?
3. Define the term Uniform Load; Concentrated Load.
4. Name the laws of mechanics that are used to determine the reactions for a simple beam.
5. Define Vertical Shear and Bending Moment.
6. As, "the sum of the forces," as well as, "the sum of the moments of the forces," acting on each side of the section are equal, why is it necessary to use the expression, "acting to the left of the section," in giving the above definitions?
7. From the definitions of the bending moment and vertical shear, write the expression for each in terms of a variable distance from the left end of the beam.
8. Why is it necessary to say, "moments being taken about a point in that section," in defining the bending moment at any section?
9. Define Resisting Shear; Resisting Moment.

10. Certain laws are deduced from experimental observations made on beams under the action of bending forces. What are they?

11. What is the Neutral Surface of a beam? the Neutral Axis of a section of a beam?

12. Show that the neutral axis passes through the center of gravity of the section.

13. Prove that $S = \frac{Mc}{I}$.

14. State clearly what each symbol in the equation $S = \frac{Mc}{I}$ means, and the units that should be used in substituting for each.

15. What conditions as to loads and material must any beam satisfy in order that $S = \frac{Mc}{I}$ will be true for that beam?

16. What is a Modulus of Rupture?

17. Define the term Strength of a beam.

18. Show that the strength of any beam depends on the value of α , where α is a number depending on the kind of a beam and the nature of the loading.

19. What is a Shear diagram? a Moment diagram?

20. Define the Shear and Moment line.

21. The shear line for a beam carrying only concentrated loads consists of horizontal and vertical straight lines. Why?

22. When only uniform loads are considered, the shear line is a straight line from end to end. Why?

23. Show that for a beam with both concentrated and uniform loads, the moment line will be a series of curved lines. If there are no uniform loads, show that the moment line will consist of a succession of straight lines at different inclinations.

24. If any part of the moment line is straight and parallel to the line representing the beam, what can you say of the bending moments for any sections taken in that part of the beam?

25. Define the expression, "the Dangerous Section of a beam."

26. Give the relation that exists between the maximum bending moment for any beam, and the vertical shear for that section.

27. Show that the problem of finding the section of a beam where the bending moment is a maximum, is the same as that of finding the section where the vertical shear passes through zero.

28. What are overhanging beams?

29. How do they differ from simple beams?

30. Show why the reactions may be found in the same manner as for simple beams.

31. What is meant by the term Inflection Point?

32. If the vertical shear is zero at more than one section of a beam, how can you find the greatest bending moment for that beam?

33. When is a beam said to be one of Uniform Strength?

34. Show that if the section of any beam is varied so that $\frac{I}{c}$ varies with M , the beam will be one of uniform strength.

35. When are the loads on a beam called Moving Loads?

36. Give the criterion for the position of a system of moving loads that causes a maximum bending moment.

37. If there is more than the one position of the loads that satisfies the criterion, how can you tell which position causes the largest bending moment?

PROBLEMS

1. Find the reactions for a simple beam carrying a uniform load of w lb./in. The length is l in. and the whole weight W lb.

SOLUTION. As the whole load is W , the sum of the two reactions must equal W or

$$R_1 + R_2 = W.$$

Taking moments about a point in the line of action of R_2 , since the resultant of the uniform loads act at the center of the beam,

$$R_1 l - \frac{Wl}{2} = 0,$$

$$R_1 = \frac{W}{2} = \frac{wl}{2} \text{ and } R_2 = \frac{wl}{2}.$$

2. Find the reactions for a simple beam, length l , carrying a single concentrated load P at a distance p from the right support.

SOLUTION. The sum of the reactions equals the loads; hence

$$R_1 + R_2 = P.$$

Taking moments about a point in the line of action of R_2 ,

$$R_1 l - Pp = 0,$$

$$R_1 = \frac{Pp}{l}.$$

Substituting the value of R_1 ,

$$\frac{Pp}{l} + R_2 = P \text{ or } R_2 = P \left(l - \frac{p}{l} \right).$$

3. Find the reactions for a simple beam 10 ft. long carrying a uniform load of 500 lb./ft.

4. Find the reactions for a simple beam 30 ft. long carrying a load of 10 tons at a distance of 20 ft. from the left end of the beam.

5. Find the reactions for a simple beam 30 ft. long carrying two equal loads of 5 tons each at 10 ft. from either end, and a uniform load of 500 lb./ft.

6. Find the vertical shears at the middle and at the ends of the beam in problem 3.

SOLUTION. From the definition of vertical shear, V at a section taken just to the right of R_1 is the value of that reaction, or 2500 lb.

At the middle of the beam the force acting upward is simply the left reaction, and the forces on the left of the section that act down are the unit loads on that part of the beam, or one half the total uniform load. Therefore the vertical shear at the middle is

$$2500 - 2500 = 0.$$

At the right end just to the left of the right reaction

$$2500 - 5000 = -2500 \text{ lb.}$$

or the vertical shear at R_2 is -2500 lb.

7. Find the vertical shears in the beam given in problem 4, at sections taken just to the right and left of the load and at each end of the beam.

8. Find the vertical shears in the beam in problem 5, at each end of the beam and at sections taken just to the right and left of each load.

9. Find the bending moment at the middle of a simple beam, length l in.,

(a) for a load P at the middle.

(b) for a uniform load of w lb./in.

SOLUTION FOR (a). The reactions are each $\frac{P}{2}$, hence by the definition of the bending moment, for a section $\frac{l}{2}$ from the left end of the beam $M = \frac{P}{2} \times \frac{l}{2} = \frac{Pl}{4}$, as there are no other forces acting between R_1 and P .

10. Find the bending moments at section just to the right and left of the load on the beam given in problem 2.

11. Find the bending moment at the wall for a cantilever beam, length l in., when the beam carries,

(a) a uniform load of w lb./in.

(b) a single load P at the free end.

(c) a single load P at p in. from the free end.

SOLUTION for (a). As there is no left reaction, the bending moment is the moment of the forces acting on the beam about a point in a section taken at the wall. The moments of all the uniform forces being equal to the moment of their resultant, let the resultant of the forces wl equal W ; then

$$M = -W \frac{l}{2} = -\frac{wl^2}{2}.$$

12. Find the bending moment at each load and at the middle of the beam given in problem 5.

13. A cast iron bar 1 by 1 in. in section and 36 in. long is broken as a beam. The modulus of rupture is 35,000 lb./sq. in. Required the maximum bending moment.

14. Draw the shear diagrams approximately to scale for simple beams 30 ft. in length loaded with

(a) a uniform load of 100 lb./ft.

(b) a concentrated load of 3000 lb. at the middle.

(c) a uniform load of 100 lb./ft. and a load of 3000 lb. at the middle.

(d) two equal concentrated loads at 5 and 10 ft. from the left end.

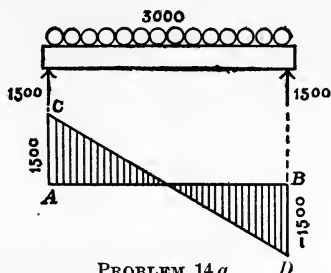

SOLUTION FOR (a). The vertical shear at any section distant x from the left end is

$$V = 1500 - 100x.$$

This is the equation of a straight line, and as V is 1500 lb. at the left support and -1500 lb. at the right support, if AB is 30 ft., $AC = 1500$ lb., and $BD = -1500$ lb., then the line through the points C and D will be the shear line, and the diagram $ABDC$ will be the shear diagram.

15. Draw the shear diagram approximately to scale for a cantilever beam 10 ft. long loaded with

(a) a uniform load of 500 lb./ft.

(b) a concentrated load of 500 lb. at the left end.

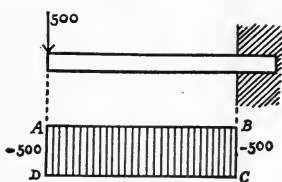
PROBLEM 15 *b*.

(*c*) a uniform load of 500 lb./ft. and a concentrated load of 5000 lb. at the free end.

(*d*) two equal loads 2500 lb. each at 5 and 8 ft. from the free end of the beam.

SOLUTION FOR (*b*). The equation of the shear line is $V = -500$, since there is no left reaction and the only load is 500 lb. at the end.

Therefore, the shear line will be a straight line parallel to AB and at a distance -500 from that line. $ABCD$ is the shear diagram.

16. Draw the moment diagrams approximately to scale for the beams as given in problems 14 and 15.

SOLUTION FOR THE BEAM IN 14 *a*. The value of the bending moment at any section x from the left end is

$$M = R_1x - \frac{wx^2}{2} = 1500x - 100\frac{x^2}{2},$$

where x is in feet. Giving any values to x , the corresponding value of M may be found.

When $x = 0$,	$M = 0$.
$x = 5$ ft.,	$M = 6250$ ft. lb.
$x = 10$ ft.,	$M = 10,000$ ft. lb.
$x = 15$ ft.,	$M = 11,250$ ft. lb.

As the loads are symmetrical with the middle of the beam, the values of M for x equal 20, 25, and 30 ft. will be the same as for x equal 10, 5, and 0 ft. Let $AB = 30$ ft. and CD, EF, GH , etc., represent on some scale the values of M corresponding to x equal 5, 10, 15 . . . 30 ft.; then a smooth curve passing through ADF , etc., will be the moment line, and the figure AHB will be the moment diagram.

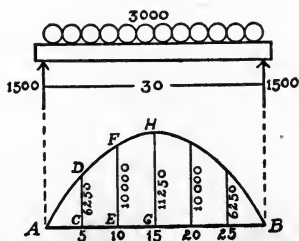

PROBLEM 16.

17. Write the expressions for the value of M and V for any section of the beam, and determine the maximum bending moments and vertical shears,

- (a) for a simple beam loaded uniformly with W lb.
 - (b) for a simple beam loaded at the middle with W lb.
 - (c) for a cantilever beam loaded uniformly with W lb.
 - (d) for a cantilever beam loaded with W at the end.
- The length of all the beams being l ft.

SOLUTION FOR (a). The expressions for M and V may be obtained from the general formula by making "the concentrated loads to the left of the section" equal zero.

$$\text{Therefore, } M = R_1x - \frac{wx^2}{2} = R_1x - \frac{Wx}{2}, \text{ if } W = wl,$$

and

$$V = R_1 - wx,$$

$$R_1 = \frac{wl}{2}.$$

Hence

$$V = \frac{wl}{2} - wx.$$

This expression is zero when $x = \frac{l}{2}$, and as M is a maximum when V is zero, substituting the value of x , which renders $V = 0$ in the expression for M , gives

$$M = \frac{wlx}{2} - \frac{wx^2}{2} = \frac{wl^2}{4} - \frac{wl^2}{8} = \frac{wl^2}{8} = \frac{Wl}{8}.$$

Evidently V is a maximum when x is zero.

18. A simple beam is 20 ft. long and carries two concentrated loads, one 100 lb. at 5 ft. and the other 500 lb. at 8 ft. from the left end, and a uniform load of 100 lb./ft. extending over the beam for a distance of 12 ft. from the right end of the beam. Draw the shear and moment diagrams and calculate the maximum bending moment and vertical shear.

19. A simple wooden beam 20 ft. long, 8 in. wide, 10 in. deep, carries a uniform load of 80 lb./ft. Required the maximum unit stress in the beam.

SOLUTION. For a uniformly loaded simple beam the maximum value of M is :

$$\frac{Wl}{8} = \frac{80 \times 20 \times 20 \times 12}{8} = 48,000 \text{ in. lb.},$$

and

$$\frac{c}{I} = \frac{\frac{d}{2}}{\frac{bd^3}{12}} = \frac{6}{bd^2} = \frac{6}{8 \times 10^2} = \frac{6}{800},$$

$$S = \frac{Mc}{I} = \frac{48,000 \times 6}{800} = 360 \text{ lb. / sq. in.}$$

20. A simple wooden beam, rectangular in section, and 20 ft. long, is to be designed to carry a load of 240 lb. at the middle with a maximum unit stress of 300 lb. / sq. in.

(d may be assumed to be equal to 6 b .)

SOLUTION. The maximum bending moment is :

$$M = \frac{Pl}{4} = \frac{240 \times 20 \times 12}{4} \text{ and } \frac{I}{c} = \frac{bd^2}{6} = \frac{d^3}{36},$$

and $\frac{M}{S} = \frac{I}{c} \therefore \frac{M \times 36}{S} = d^3.$

Whence $d^3 = \frac{240 \times 20 \times 12 \times 36}{4 \times 300} = 1728$, or $d = 12$, $b = 2$.

21. A simple wooden beam is 1 foot square and 10 yd. long. What uniform load can it carry if the unit stress is not to exceed 300 lb. / sq. in. ?

22. If the beam in problem **21** also carried a load of 1000 lb. at the middle, what uniform load may also be carried if the unit stress is not to exceed 400 lb. / sq. in. ?

23. Two planks, 12 in. wide and 2 in. thick, are placed one on top of the other and used as a simple beam. They support a uniform load of 1000 lb. What is the maximum unit stress in the material? What would it be if the planks were placed side by side and carried the same load ?

24. A simple beam of wrought iron is 4 in. wide, 6 in. deep, 12 ft. long, and carries a uniform load of 32,000 lb. Is it safe ?

25. If the beam in problem 24 was a cantilever beam, what uniform load will it carry with a maximum unit stress not greater than the elastic limit?

26. A simple steel 10 in. I beam weighing 25 lb. / ft. is 18 ft. long and carries a uniform load, including its own weight of 15,000 lb. Required the maximum unit stress.

SOLUTION. The table gives the value of $\frac{I}{c}$ for this beam as 24.4. The maximum value of M is

$$\frac{Wl}{8} = \frac{15,000 \times 18 \times 12}{8} \text{ and } S = \frac{Mc}{I}.$$

Hence
$$S = \frac{15,000 \times 18 \times 12 \times 1}{8 \times 24.4} = 16,600 \text{ lb. / sq. in.}$$

27. Show that when the weight W of a simple beam is 2 % of the load at the center, the error in the unit stress as found by neglecting the uniform load due to the weight of the beam is about 1 %.

28. A common rule states that when the load at the center of a simple beam is greater than five times the weight of the beam the weight may be neglected when making the calculations for strength. What maximum error will this rule allow?

29. If W is the weight of a cantilever beam and P the load at the end, find the ratio of $\frac{P}{W}$ when the error in the unit stress caused by the neglect of W is 5 %.

30. Select a simple I beam of structural steel 24 ft. long to carry a load of 12,500 lb. at the middle with a factor of safety of 4.

The maximum value of M is

$$M = \frac{Pl}{4} = \frac{12,500}{4} \times 24 \times 12. \quad S = \frac{60,000}{4} = 15,000 \text{ lb./sq. in.}$$

$$\frac{M}{S} = \frac{I}{c} = \frac{12,500 \times 24 \times 12}{4 \times 15,000} = 60.$$

The table gives the value of I for a 15 in. beam weighing 45 lb./ft. as 60.8, and as $P = 15 W$, this beam will satisfy the conditions.

31. Select a standard steel I beam 10 ft. long to be used as a cantilever beam, to carry a load of 4 tons at the free end. Factor of safety 4.

32. Select a simple steel I beam for a span of 20 ft. to carry two equal loads of 2 tons each at 5 ft. from either end and a uniform load of 300 lb. / ft., the unit stress not to be greater than 16,000 lb. / sq. in.

33. If the term Coefficient of Strength is defined as the product of the total uniform load on a simple beam multiplied by the length of the beam in feet, show that $\frac{I}{c}$ varies as this product.

34. Show that the coefficient of strength for a simple beam carrying a concentrated load at the middle is twice that for the same load uniformly distributed.

35. Find the relative values of the coefficient of strength for cantilever beams uniformly loaded, and loaded at the free end, compared with the same load uniformly distributed over a simple beam.

36. Select a standard steel channel 12 ft. long to be placed with the flanges vertical and used as a simple beam to carry a uniform load of 15,000 lb. Factor of safety 4.

37. A beam 30 ft. long is supported at points 10 and 5 ft. from the right and left ends. There is a uniform load of 500 lb. / ft. between the supports and concentrated loads of 450 lb. at either end of the beam.

(a) Draw the shear and moment diagrams.

(b) Find the greatest bending moments and vertical shears.

(c) Find the inflection points.

(d) Select a steel I beam to carry the loads with a maximum unit stress of 16,000 lb. / sq. in.

38. A beam supported at two points 18. ft. apart overhangs each support 6 ft. The overhanging ends carry a

uniform load of 300 lb. / ft. and there is a concentrated load of 12,000 lb. at the middle of the beam.

(a) Draw the shear and moment diagrams.

(b) Find the greatest bending moment and vertical shear.

(c) Find the inflection points.

(d) Select a steel I beam to carry the loads with a maximum unit stress of 16,000 lb. / sq. in.

39. Three men carry a stick of timber 12×12 in. \times 12 ft. long. One man is at one end and the other two are at such a point that each of the three men carries an equal load. Find that point.

40. A cantilever beam of uniform strength rectangular in section is 12 ft. long and carries a load of 1200 lb. at the free end. The material is cast iron and the factor of safety is 10.

Find the largest and smallest sections and make sketch showing the plan and elevation of the beam when,

(a) the width is constant at 4 in.

(b) the depth is constant at 12 in.

41. A simple beam of uniform strength is rectangular in section and 12 ft. long and carries a uniform load of 9600 lb. The material is cast iron and the factor of safety is 10. Find the smallest and largest sections and make a sketch showing the plan and elevation of the beam when,

(a) the width is constant at 4 in.

(b) the depth is constant at 12 in.

42. If the beam in problem 38 was a rectangular steel beam of uniform strength and constant depth, find the proper size for the largest section when $b = d$ for that section and the safe working unit stress is 16,000 lb. / sq. in. If the allowable unit stress in shear is 10,000 lb. / sq. in., find the area of the least section possible. Make a sketch of the plan of the beam.

43. Two equal loads are 6 ft. apart. Find their position as they are moved over a simple beam 20 ft. long that gives the greatest bending moment in the beam.

44. Three loads each 4 ft. apart are moved over a beam 18 ft. long. From left to right the loads are 4000, 2000, and 2000 lb. Find the position of the loads that gives the greatest bending moment in the beam.

45. As the loads (problem 44) pass over the beam from right to left, show that the maximum vertical shear for any position of the loads is given by $V = \left(1 - \frac{a+b}{l}\right)8000$, where a is the distance of the 4000-lb. load from the left support, and b the distance of the resultant of the loads from the same load.

46. As the loads pass over the beam (problem 44), make a diagram, using as ordinates the vertical shear to the left of the 4000-lb. load and as abscissa the distance of that load from the left end of the beam.

47. If Q is the resultant of a system of loads moving over a simple beam, x the distance of Q from the left end, and a the distance of Q from the middle of the beam, show that the conditions for maximum moment require that

$$l - x = x - 2a \text{ when } x > \frac{l}{2},$$

and

$$l - x = x + 2a \text{ when } x < \frac{l}{2};$$

and if this condition is satisfied, that the value of the maximum moment is given by

$$M_{\max} = \frac{Q}{l}(x \pm 2a)^2 - \left\{ \begin{array}{l} \text{the moments of the loads on} \\ \text{the left of the dangerous section.} \end{array} \right\}$$

CHAPTER IV

TORSION

ARTICLE 52. Derivation of Formula.

In the previous chapters the forces were assumed to act in a plane passing through the axis and were either parallel or perpendicular to the axis.

The forces that produce the stress known as torsion act in planes that are perpendicular to the axis of the bar, and while the lines of action of the forces are perpendicular to it, they do not pass through the axis.

The effect of such forces must be to twist the bar. Assume a cylindrical bar, one end of which is firmly fixed in the wall, to be acted on by a couple lying in a plane perpendicular to the axis of the bar at a distance l from the wall, and whose moment about that axis is Pp . A fiber of the bar that

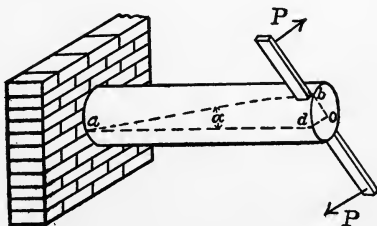

FIG. 52 a.

before the application of the force occupied the position of the line ad (Fig. 52 a), after the force has been applied will occupy the position of the helix ab , and a point d on the surface of the bar will have moved to the position b .

It is evident that the angle bad , the angle of the helix, is independent of the length of the bar and depends only

on the twisting forces and the material of the bar. Since any plane section perpendicular to the axis of the bar between the wall and the couple would contain an arc similar to bd , and the length of that arc is proportional to the distance from the wall, the angle bod is proportional to the length of the bar and the twisting forces.

This angle is called the angle of twist, and will be denoted by θ .

By analogy with tension, the distance a point on the end of the bar moves under the action of the twisting forces being similar to the distance a point on the end of a tension bar moves under the action of the tensile forces, the arc bd may be taken as a measure of the deformation of the surface fibers of the bar due to the twisting forces.

As the arc bd was proportional to the length, $\frac{bd}{l}$ can be taken as representing the unit deformation.

Experiment has proven that when a bar is circular in section and no stress is greater than the elastic limit, the

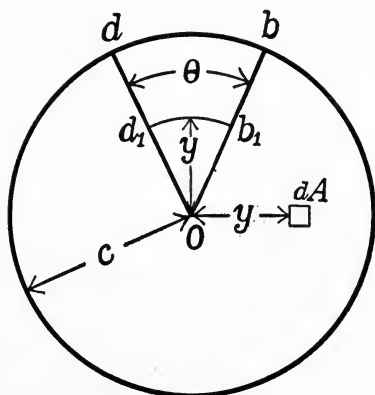

FIG. 52 b.

line od , moved to any new position during the twisting of the bar, remains a straight line. This being true, the length of any arc d_1b_1 (Fig. 52 b), with a center at O and a radius y , is proportional to its radius, and as the arc is proportional to the deformation at the radius y , the force producing this deforma-

tion is proportional to the same distance. This reasoning is true for any perpendicular section of the bar between the plane of the couple and the wall.

Assume the bar to be cut by a plane perpendicular to the axis between the wall and the twisting couple, and introduce forces in that section to render the free end in equilibrium. These forces must all act in a plane perpendicular to the axis, since the external couple has no component perpendicular to such a plane, and their resultant must be equivalent to a couple whose moment is equal to that of the twisting moment.

Considering the two faces of the bar in any section, it is evident that the face on the right end tends to slide against the face on the left end as the former tends to rotate about the axis of the bar, thus producing a shearing stress throughout the section. Since the force, and consequently the unit shearing stress, is proportional to the distance from the center of the bar, if we let S_s be the unit shearing stress in the surface fibers, c be the distance of those fibers from the axis of the bar, and y be the distance of any fiber from the same axis, then $\frac{S_s}{c}$ is the unit stress at a unit's distance from the axis and $\frac{S_s}{c}y$ is the unit stress at any distance y .

Considering the stress uniformly distributed over any small area dA at the distance y , $\frac{S_s}{c}y dA$ is the force acting on that elementary fiber, and $\frac{S_s}{c}y^2 dA$ is the moment of this force about the axis of the bar. But the sum of the moments of the forces acting in the section is equal to the twisting moment Pp , hence $\frac{S_s}{c} \int y^2 dA = Pp$. $\int y^2 dA$ is

the expression for the polar moment of inertia about an axis through the center of gravity of the section, and writing J for

$$\int y^2 dA \text{ gives } Pp = \frac{SJ}{c}, \quad (e)$$

which shows the relation between the maximum unit stress in shear and the twisting forces.

ART. 53. Modulus of Section.

Comparing formula (e) with $M = \frac{SI}{c}$, it will be noticed that they are of the same general form. M and Pp represent the effect of the external forces, S in each case is the maximum unit stress in the section, and by analogy with $\frac{I}{c}$, $\frac{J}{c}$ may be called a modulus of the section. Formula (e) is only true for bars whose sections are circular, and where the material and loading of the bar satisfies the conditions stated for $M = \frac{SI}{c}$.

ART. 54. Square Sections.

For rectangular sections the formula is only approximately true, as a radial line drawn from the corner does not remain straight during the twisting of the bar, as was the case with the circular section.

The investigations of St. Venant cover the rectangular section, and his results give for a rectangular shaft subjected to torsion,

$$Pp = S_s \frac{d^3}{4.8} \text{ (nearly),}$$

in which d is the side of the square. From the form of the expression the effective value of $\frac{J}{c}$ must be $\frac{d^3}{4.8}$ instead

of the calculated value $\frac{\sqrt{2}d^3}{6}$, hence the value of Pp as found from the above formula is less than that obtained from equation (e), when equal values of S_s and d are used.

Square sections are apt to be weaker than St. Venant's formula would indicate, since the maximum stress is carried on the edge of the square and any slight defect reduces the effective diameter of the bar.

For this reason square sections are rarely used to resist torsion alone.

ART. 55. Illustrations.

The resistance at the wall may be assumed as another couple, whose moment is equal and opposite to that of the twisting moment, without altering the conditions as assumed when formula (e) was developed. In the case of a line shaft, where the belt from the engine produces a twisting moment at one end of the shaft, the resistance of the belt on the pulley at the other end is equivalent to an equal moment. If there are several pulleys on the same shaft, each producing a moment by its resistance to turning, it is evident that the resisting moment of the shaft will not be constant throughout the length, but will vary with the resistance that it has to overcome. To illustrate, assume a shaft with three pulleys, one at each end and one at the middle of the shaft. The driving moment is applied at the left end and the resisting moment of the other two pulleys, P_1p_1 and P_2p_2 , must be equal to the driving moment Pp . The moment to be resisted by the shaft between the driving pulley and the one at the middle is $Pp = P_1p_1 + P_2p_2$. After passing

the middle pulley the resistance to be transmitted by the shaft is only the twisting force of the third pulley, and consequently the resisting moment between the second and third pulleys is equal to $P_2 p_2$.

ART. 56. Twist of Shafts.

In Fig. 52*b*, db was taken as a measure of the deformation of the surface fiber, and $\frac{db}{l}$ the unit deformation of that fiber. From the figure $db = \theta c$ and by the definition of the modulus of elasticity, if S_s is the unit stress in the surface fibers, the shearing modulus of elasticity must be

$$F = \frac{S_s}{\frac{db}{l}} = \frac{S_s l}{\theta c} \quad \text{or} \quad \frac{Ppl}{\theta J}. \quad (f)$$

The latter expression is obtained by substituting for S_s its value from $S_s = \frac{Ppc}{J}$.

Equation (*f*) gives the relation between the modulus of elasticity for shear, the twisting moment or the unit shearing stress, and the angle of twist.

When the data given in any problem is sufficient to determine two of the three quantities, the twisting moment, the unit shearing stress, or the section modulus, the formula $Pp = \frac{S_s J}{c}$ will completely determine the other one. Or when the given data will determine three of the following quantities, the twisting moment or the unit shearing stress, the dimensions of the bar, the angle of twist, and the shearing modulus of elasticity, formula (*f*) can be used to solve any problem involving the twisting moment or the unit stress and the angle of twist.

Since all of the tabulated values of the constants of materials are given in pounds and inches, all dimensions of weight and linear or square measure must be reduced to pounds and inches before making the substitutions in the formulas. As the value of θ used in the development of the formula was in circular measure, θ must be expressed in radians.

ART. 57. Relative Strengths and Stiffness of Shafts.

The strength of a shaft may be defined as the twisting moment it will carry with a given unit stress. Formula (e) shows that the strengths of shafts vary directly as the value of $\frac{S_s J}{c}$ for each shaft, and when the shafts are of the same material, as $\frac{J}{c}$.

Defining the stiffness of a shaft as the angle of twist for a given value of Pp , since $\theta = \frac{Ppl}{FJ}$ or $\frac{S_s l}{Fc}$, it is evident that the stiffness of two shafts of the same material varies directly as $\frac{l}{J}$ or $\frac{l}{c}$, depending on whether the twisting force is given directly or in terms of the stress.

ART. 58. Horse Power of Shafts.

A horse power being defined as 33,000 ft.-lb. per minute, if H is the horse power to be delivered by a shaft making N revolutions per minute, the value of Pp in terms of the horse power may be found from the equality of the work done by the twisting force per minute and the work represented by H horse powers. Assuming that P is a force acting at a radius p , the work done by that force in one revolution must be $2\pi Pp$ in.-lb. and as a horse power is 33,000 ft.-lb. per minute, or 396,000

in.-lb. per minute, $2\pi PpN = 396,000 H$, which reduces to $H = \frac{PpN}{63,000}$ (approximately). Substituting for Pp its value in terms of S_s from formula (e), gives $H = \frac{S_s JN}{63,000 c}$. These two expressions may be used to determine the horse power that a given shaft will transmit when the number of revolutions per minute and the twisting moment or the maximum unit stress are known. The values of either Pp or S_s may be found from (f) and the angle of twist for a given horse power determined.

ART. 59. Shaft Couplings.

When two lengths of shafting are to be joined together, the connection is often made as in Fig. 59. The moment

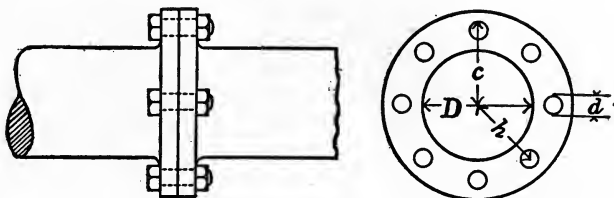

FIG. 59.

of the shearing stresses in the bolts must be equal to the twisting moment of the shaft, and the relation between the twisting moment of the shaft and the resisting moment of the bolts may be stated as $Pp = S_s' \frac{J'n}{c'}$, where J' is the polar moment of inertia of the section of a bolt about the axis of the shaft, n the number of bolts, S_s' the maximum unit stress in the bolts, and c' the distance of the most distant fiber of the bolt from the axis of the shaft.

If the bolts and shaft are of the same material, then $\frac{J}{c} = \frac{J'n}{c'}$, where J and c refer to the shaft and J' and c' to the bolts. The polar moment of inertia of the bolt about the axis of the shaft is equal to $J' = J_g + Ah^2$, where J_g is the polar moment of the bolt section about an axis through its center of gravity, and h is the distance of the axis of the bolt to the axis of the shaft. Expressing $\frac{J}{c}$ and $\frac{J'n}{c'}$ in terms of the diameters of the shaft and bolts, gives a method for finding the proper diameter of the bolts to be used. The equation thus formed gives a very awkward expression for the value of the diameter of the bolts, and it is common practice to assume that the shearing stress is uniformly distributed over the area of the bolts. This is equivalent to assuming that the resultant of the shearing stresses acts at the center of the bolts.

Let S_s'' be the uniform unit shearing stress in the bolts, h the radius of the bolt circle, or the distance between the center of the shaft and the center of the bolts, and d the diameter of the bolts; then the resisting moment of the bolts must be $n\frac{\pi d^2}{4}S_s''h$, and equating this to the twisting moment of the shaft gives

$$Pp = n\frac{\pi d^2}{4}S_s''h,$$

which is in convenient form for use in the determination of the bolt diameters.

As the resisting moment of the bolts must be equal to the resisting moment of the shaft, if S_s is the maximum unit stress in the shaft and D the diameter, then

$$\frac{S_s J}{c} = n\frac{\pi d^2}{4}S_s''h$$

gives the relation between the unit shearing stresses in the shafts and bolts. Either the number of the bolts, their diameter, or the radius of the bolt circle can be taken as unknown.

In applying the approximate solution to the solution of a problem, the total bolt area, $n \frac{\pi d^2}{4}$, needed, may be found and the number of bolts chosen that will give the required area. The assumption made in the approximate solution is also equivalent to assuming that $J' = \frac{\pi d^2 h^2}{4}$ and $c' = h$. Comparing the exact and approximate values of $\frac{J'}{c'}$, we find that the approximate value is nearly 10 % larger than the accurate one, when $h = 4 d$. The error will increase as the ratio of h to d increases, and of course decrease as that ratio decreases. The error, while not of much importance in the majority of cases, should always be considered when the decision is made regarding the diameters, the total bolt area as found by the approximate solution being less than the true area.

ART. 60. Modulus of Rupture in Torsion.

When the twisting moment $P\rho$ is great enough to rupture the bar, the value of S_s as found by equating this value of $P\rho$ to $\frac{SJ}{c}$ has been called the modulus of rupture in torsion. The value of such a constant of material is doubtful, as the formula is not true when the unit stress is greater than the elastic limit. It would seem to be better practice to use the maximum unit stress in shear, as determined by the use of $P = AS$ as the maximum unit stress in torsion, and base any factor of safety on that constant.

ART. 61. Helical Springs.

When a wire is wound around a cylinder so that the axis of the wire forms a helix, the resulting form of the wire is called a helical spring. Take such a spring made from wire whose diameter is d and wound on a cylinder so that the diameter of the helix is D , compressed or extended by the force P whose line of action passes through the centers of all the coils, and consider one coil. If the spring is closely

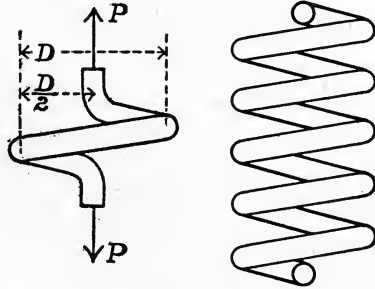

FIG. 61.

wound and D is large compared with d , the plane of the coil will be nearly perpendicular to the line of action of the force; hence the force P acting with a lever arm $\frac{D}{2}$ tends to twist the wire.

The twisting moment is $\frac{PD}{2}$ and the section modulus of the wire $\frac{\pi d^3}{16}$; hence, taking S_s as the unit stress $\frac{PD}{2} = \frac{\pi d^3}{16} S_s$, or $P = \frac{\pi d^3}{8D} S_s$, gives the relation between the tensile or compressive force P and the dimensions of the spring.

The length of one coil of the spring is approximately πD , and if the wire is twisted through a small angle θ , by a moment that increases uniformly from 0 to $\frac{PD}{2}$, the work done on the wire of one coil is $\theta \frac{PD}{4}$, where θ is in circular measure. If we let Δ be the total deflection of the spring, that is the amount of shortening or lengthening,

and δ the deflection for one coil, as the force acting varied uniformly from 0 to P , the work done on one coil is $\frac{\delta P}{2}$. Since these two expressions represent the same quantity of work, they must be equal, or $\theta \frac{PD}{4} = \frac{\delta P}{2}$ or $\theta = \frac{2\delta}{D}$.

As θ is the angle of twist, formula (f) gives as its value

$$\theta = \frac{Ppl}{FJ} = \frac{16 D^2 P}{Fd^4}.$$

Equating the two values of θ ,

$$16 \frac{D^2 P}{Fd^4} = \frac{2\delta}{D} \text{ or } \delta = \frac{8 PD^3}{Fd^4},$$

which is the deflection of one coil in terms of the load P .

Taking

$$\theta = \frac{S_s l}{Fc} = \frac{2\delta}{D},$$

we have $\delta = \frac{S_s \pi D^2}{Fd}$ as the relation between the unit stress and the deflection for one coil.

Since the strength of any bar under the action of twisting forces is independent of the length of the bar, the formula for the strength of a spring is also independent of the number of coils. If n is the number of coils, the total deflection of any spring must be n times the deflection for one coil, or

$$\Delta = \frac{8 PD^3 n}{Fd^4} \text{ or } \frac{S_s \pi D^2 n}{Fd}$$

EXAMINATION

1. What is a torsional force? How does it differ from a force that produces a shearing stress that is uniform over the section of a bar?

2. Can a torsional force produce any tensile or compressive stresses?

3. "It is evident that the angle bad is independent of the length of the bar." Prove it.

4. Show that the angle of twist depends on the length of the bar.

5. If a straight radial line drawn on the end of a bar remains straight when the bar is being twisted, show that this fact proves that the unit stress is proportional to the distance from the axis.

6. Show that $S_s = \frac{Ppc}{J}$.

7. State under what conditions of load and material the formula $Pp = \frac{S_s J}{c}$ is true.

8. Define the terms "strength of a shaft"; "stiffness of a shaft."

9. Does the strength of a shaft depend on its length? Is the same true of the stiffness?

10. Two shafts of the same diameter and length are of different materials. What is their relative strength? What is their relative stiffness?

11. Show how to find the expression for the modulus of elasticity in shear.

12. Why was it necessary to reduce the value of a horse power, 33,000 ft.-lb., to inch-pounds in order to obtain the expression

$$H = \frac{S_s J N}{63,000 c} ?$$

PROBLEMS

1. One end of a circular bar 2 in. in diameter and 10 ft. long is fixed in a wall, and at the other end there is a couple whose moment is 300 ft.-lb. Required the unit stress in the bar?

SOLUTION. The value of $J = \frac{\pi d^4}{32}$ and $c = \frac{d}{2}$; hence $\frac{J}{c} = \frac{\pi d^3}{16}$.
 $Pp = 300 \text{ ft.-lb.} = 3600 \text{ in.-lb.}$

Substituting these values in $P\rho = \frac{SJ}{c}$, and solving for S_s , gives

$$S_s = \frac{3600 \times 16}{\pi \times 8} = 2290 \text{ lb./sq. in.}$$

2. A circular bar 7 in. in diameter, 10 ft. long, is acted on by a force of 10 tons perpendicular to, and at a distance of 3.14 ft. from the axis. Required the unit stress induced.

3. Find the diameter of a circular steel bar to carry a twisting moment of 20 ft.-tons.

4. Find load that can be applied at the end of an arm 6 ft. long so that the maximum unit stress induced in a circular bar 2 in. in diameter will not exceed 12,000 lb./sq. in.

5. A circular steel bar 2 in. in diameter is twisted by a force at the end of an arm 6 ft. long. Required the force if the unit stress due to torsion is equal to the elastic limit.

6. If the bar in problem 1 was soft steel, find the angle of twist.

SOLUTION. Taking the values as found for 1 and substituting in $\theta = \frac{Sl}{Fc}$, $l = 10 \times 12$ in. and $F = 12,000,000$,

$$\theta = \frac{2290 \times 10 \times 12}{12,000,000 \times 1} = \frac{22,900}{1,000,000} = .0229 \text{ radian,}$$

or approximately $1^\circ 18'$.

7. A soft steel bar is 6 in. in diameter and 20 ft. long. What force acting tangent to the surface will twist the bar through an angle of 1° ?

8. A steel shaft 2 in. in diameter and 50 ft. long is transmitting a torsional moment that causes a unit stress equal to the elastic limit. Required the angle one end is twisted through relative to the other.

9. Find the diameter of a steel shaft 10 ft. long to carry a twisting moment of 81,700 ft.-lb., if the unit stress is not to be greater than 10,000 lb./sq. in., and the angle of twist less than 1.15° .

10. Find the diameter of a steel shaft making 100 revs./min. and transmitting 200 H.P., the unit stress being 6300 lb./sq. in.

$$\text{SOLUTION. } H = \frac{S_s J N}{63,000 c} = \frac{6300 \times \pi \times d^3 \times 100}{63,000 \times 16} = 200,$$

$$d^3 = \frac{200 \times 63,000 \times 16}{6300 \times \pi \times 100} = 4.67 \text{ in.}$$

The shaft chosen would be either $4\frac{1}{2}$ or 5 in. in diameter.

11. The Allis Chalmers Co. base their tables for the strength of mild steel shafting on the formula $H = cd^3 N$, where d is the diameter of the shaft in inches, and c a number which has the following values:

For heavy or main shafts $c = .008$

For shafts carrying gears $c = .010$

For light shafts carrying pulleys $c = .013$

Find the unit working stress allowable in each case.

12. 6000 H.P. is to be transmitted through a shaft. If the shaft is a hollow cylinder 36 in. outside diameter, find the inside diameter. Take the unit stress as 12,000 lb./sq. in. and the revolutions per minute as 90.

13. A coupling is to be used to connect two lengths of shafting 4 in. in diameter. The maximum allowable unit stress in the shaft is 10,000 lb./sq. in., the diameter of the bolt circle is 6 in., and the allowable unit stress in the bolts is 8000 lb./sq. in. Find the diameter and number of bolts necessary, assuming that the shear is uniformly distributed over the section of the bolts.

14. A hollow shaft has the outside diameter twice the inside diameter. Compare its strength with that of a solid shaft of the same material and section area.

15. If the elastic limit of the material in one shaft is 60,000 lb./sq. in. and costs 10¢ per pound, what can



you afford to pay for a shaft to do the same work, if the elastic limit of the material is 30,000 lb. /sq. in.?

16. A helical spring is made of wire whose diameter is 1 in., the mean diameter of the coil 4 in., and has 30 coils. If the value of F is 12,000,000 and the working unit stress 60,000 lb. /sq. in., required the load it will carry and the deflection under that load.

17. A helical spring has to carry a load of 5890 lb. and has a deflection under that load approximately 10 in. The unit stress, diameter of the wire, number of coils and the modulus of elasticity in shear are the same as in problem 16: find the diameter of the coils.

18. D. K. Clark gives as the deflection for one coil of a helical spring $\delta = \frac{D^3 P}{22 d^4}$, where d is the diameter of the wire in sixteenths of an inch.

CHAPTER V

THE ELASTIC CURVE

ARTICLE 62. Definition.

When the beam is bent, the neutral surface assumes a curved form; and the projection of this surface on a vertical plane parallel to the axis of the beam is called the *Elastic Curve*. If the equation of this curve for any beam is expressed as $y = f(x)$, where y is the deflection of the beam at any point distant x from the left end of the beam, the deflection of the beam at any point can be easily found.

ART. 63. Equation of the Elastic Curve.

To derive this equation of the elastic curve let Fig. 63 represent a portion of a bent beam.

Let ji measured along the axis of the beam be taken as representing dl , where l is the length of the beam and the curve dl a differential part of

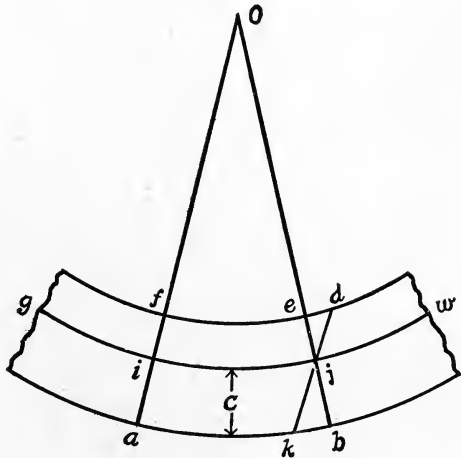

FIG. 63.

the elastic curve, then if o is the center of curvature, oi and oj are radii. Before any bending took place these radii were parallel to each other, and eb may be assumed to have been in the position kd parallel to af . Let the greatest distance of the neutral axis to the surface fiber be c and assume that $jb = c$. The deformation of the outer fiber is kb and the unit deformation is $\frac{kb}{dl}$, since kb is the change in the length dl ; E is the modulus of elasticity, and S the unit stress in that fiber, hence $kb = \frac{Sdl}{E}$. From the similar triangles $jk b$ and oij

$$\frac{kb}{ji} = \frac{jb}{oj}. \quad (1)$$

But $oj = r =$ the radius of curvature, $ji = dl$, $jb = c$, and $kb = \frac{Sdl}{E}$; hence, substituting these values in (1), we have $\frac{Sdl}{Edl} = \frac{c}{r}$, or $\frac{S}{E} = \frac{c}{r}$; but $S = \frac{Mc}{I}$,

hence
$$\frac{M}{I} = \frac{E}{r}, \text{ or } r = \frac{EI}{M}, \quad (2)$$

is the equation of the elastic curve of a beam in terms of the modulus of elasticity, the bending moment at any point of the beam, the moment of inertia, and the radius of curvature of the elastic curve at that point.

The value of r expressed in rectangular coördinates is

$$r = \frac{\left(1 + \left(\frac{dy}{dx}\right)^2\right)^{\frac{3}{2}}}{\frac{d^2y}{dx^2}}. \quad (3)$$

Since the degree of curvature of any beam in an engineering structure is very small, the value of the tangent

of the angle which the tangent at any point on the curve makes with the axis of X is a very small quantity and $\left(\frac{dy}{dx}\right)^2$ may be neglected in comparison with unity. Equation (3) then reduces to

$$r = \frac{1}{\frac{d^2y}{dx^2}}.$$

If dx is assumed to be equal to dl , an assumption which is approximately true when the degree of curvature is small, and the value of r as just found is inserted in equation (2), we have

$$\frac{1}{\frac{d^2y}{dx^2}} = \frac{EI}{M}, \text{ or } EI \frac{d^2y}{dx^2} = M, \quad (g)$$

which is the differential equation of the elastic curve of any beam. M is the bending moment for any part of the beam for which the equation represents the curve, therefore must be expressed in terms of x any distance from the left end of the beam, and y is the ordinate to the curve or the deflection of the beam.

Since the condition that $E = \frac{S}{\epsilon}$ was introduced in the derivation, the unit stress must be within the elastic limit, and as the formula $S = \frac{Mc}{I}$ was also used, all the conditions of the materials that are necessary to the correct use of that formula obtain with the one just developed. The assumptions that $dl = dx$, and that the maximum value of $\frac{dy}{dx}$ was so small that $\left(\frac{dy}{dx}\right)^2$ might be neglected as compared to unity, introduce errors that, while they are small, increase as the degree of curvature increases. The

use of the formula under ordinary engineering conditions gives results that agree well with those obtained in experimental work, the discussion of the limitations to its use being given to show that the formula is not applicable to all cases.

ART. 64. Deflection of Beams.

Let $M = f(x)$ be the expression for the bending moment for a portion of any beam loaded in any way; then

$$EI \frac{d^2y}{dx^2} = f(x) \quad (1)$$

is the differential equation of the elastic curve for that part of the beam for which $f(x)$ represents the bending moment.

Integrating (1),

$$EI \frac{dy}{dx} = f'(x) + C, \quad (2)$$

where C is a constant of integration. The value of C may generally be found by noting that $\frac{dy}{dx}$ is the tangent of the angle which the tangent at x makes with the axis of X , and from the conditions of the problem, finding a value of x for which $\frac{dy}{dx}$ is either zero or known.

Integrating again,

$$EIy = f''(x) + Cx + C_1. \quad (3)$$

The value of C_1 , the constant of integration, can in most cases be determined by finding a value for x for which y is either zero or known.

When C and C_1 are determined, equation (3) may be used to find the deflection at any point of the beam for which the bending moment is equal to $f(x)$.

As the right hand member of equation (2) is the differential coefficient of equation (3), the value of x which renders $f'(x) + C = 0$ makes the value of y a maximum, or the maximum deflection for that part of the beam may be found. As an aid in the determination of the constants of integration, the student is reminded that when the moment diagram is symmetrical about a vertical line at the middle of the beam, $\frac{dy}{dx}$ is zero for a value of $x = \frac{l}{2}$, and for the special case of cantilever beams $\frac{dy}{dx}$ is zero at the wall, as the restraint keeps that part of the beam fixed and horizontal.

Since there is no deflection at the supports, y will always be zero at the points where the beam is supported. When there are concentrated loads on the beam, the expression for M will take a different form for each part of the beam between the loads or between the loads and reactions.

If there are n concentrated loads on the beam, there will be $n + 1$ forms that the expression for the bending moment may take, making $n + 1$ equations of the elastic curve, the double integration of each bringing into the problem $2(n + 1)$ constants of integration.

For simple beams the value of x that will make $\frac{dy}{dx} = 0$ is not known unless the loads are symmetrical with the middle of the beam, but y is always equal to zero at the supports where x is either 0 or l .

Any two of the $n + 1$ equations representing consecutive portions of the beam will have the expressions for $\frac{dy}{dx}$ and y equal for a value of x at the load where the equations meet. As there are but $2n + 2$ constants of inte-

gration, and two known conditions are always to be had from the fact that $y = 0$ when $x = 0$ or $x = l$, the $2n$ equations resulting from the equating of the values of $\frac{dy}{dx}$ and y under each load will suffice to determine the other $2n$ constants of integration.

In using equation (3) for the determination of the maximum deflection of a beam, the student is again reminded that the equation only holds true for that portion of the beam represented by $f(x)$, and where there are several concentrated loads, each portion may have to be investigated, in order to find the greatest value of y for the beam. In general, an inspection of the distribution of the loads on the beam will show the portion of the beam where the greatest deflection is likely to occur.

If the bending moments for simple and cantilever beams loaded uniformly with W , simple beams loaded at the middle with W , and cantilever beams loaded with W at the end, are expressed in terms of x , these moments may be substituted in $EI \frac{d^2y}{dx^2} = M$, forming four differential equations. Integrating each equation twice gives the value of y , the deflection of the beam for any value of x . The maximum value of the deflection y may be expressed as $f = \frac{1}{\beta} \frac{Wl^3}{EI}$, where β is a constant depending on the kind of a beam and the nature of the loads. Transposing, $W = \beta \frac{EI f}{l^3}$. The load a similar beam will carry was given as $W = \alpha \frac{SI}{lc}$, and if these two expressions for W are equated we find that $f = \frac{\alpha SI^2}{\beta Ec}$, giving the relation

between the maximum deflection, the dimensions of the beam, the unit stress, and the modulus of elasticity.

Attention is called to the way f varies in the two expressions for the maximum deflection.

When the load W is considered, f varies directly as l^3 and inversely as I , and when the unit stress is given, f varies directly as l^2 and inversely as c . For rectangular sections, this latter variation makes the maximum deflection independent of the breadth of the beam.

ART. 65. Restrained or Fixed Beams.

A beam is said to be restrained or fixed when one or both ends are so firmly imbedded in the wall that the tangent to the elastic curve at the fixed ends always remains horizontal during the flexure of the beam. A cantilever beam under this definition is a fixed beam when it projects from the wall; but since there was no reaction at the free end, the bending moments and shears can be determined without reference to the fixed end. When the free end of a cantilever beam has a support placed under it, the conditions are changed. The magnitude of the reactions can not be determined from the conditions for mechanical equilibrium that were used for simple beams. The value of M for any section of the beam will contain a term that includes the unknown reaction, and this value of M substituted in the general equation of the elastic curve will give the differential equation of the curve for this beam. When this equation is integrated twice, the value of the unknown reaction may be found by applying the known conditions that the resulting equations must satisfy.

Let Fig. 65 represent a beam fixed at one end and supported at the other, loaded in any way. If R_1 is the

reaction at the left end of the beam, the bending moment for a section distant x from that end is

$$M = R_1x - \frac{wx^2}{2} - \left\{ \begin{array}{l} \text{the sum of the moments of the loads} \\ \text{to the left of the section with refer-} \\ \text{ence to a point in that section} \end{array} \right\},$$

and putting this value of M in the general equation of the elastic curve gives

$$EI \frac{d^2y}{dx^2} = R_1x - \frac{wx^2}{2} - \left\{ \begin{array}{l} \text{sum of the moments} \\ \text{of the loads, etc.} \end{array} \right\},$$

which is the general equation of the elastic curve for a beam fixed at one end and supported at the other.

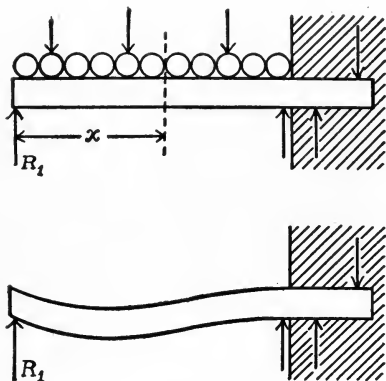

FIG. 65.

If there are no concentrated loads, the last term of the right hand member will be zero, and if there is no uniform load, $\frac{wx^2}{2}$ will be zero. In a previous article it was shown that in a general case there were $2(n-1)$ conditions for the determination of an equal number of integration constants, and in this case there is the additional condition that $\frac{dy}{dx} = 0$ when $x = l$, which may be used to determine R_1 , since the tangent to the curve is horizontal at the wall. Stated briefly, the conditions that $y = 0$ at the fixed and supported ends, $\frac{dy}{dx} = 0$ at the fixed end, and the $2n$ equations resulting from the

equating of the values of $\frac{dy}{dx}$ and y under each load, will be sufficient to completely determine the values of the $2(n - 1)$ constants of integration, and that of the unknown reaction at the left end of the beam.

ART. 66. Beams fixed at Both Ends.

Let Fig. 66 represent a beam fixed at both ends and loaded in any way. The forces which act between the beam and the walls supporting the beam, keeping the tangent to the elastic curve at the wall horizontal, are unknown. The unknown systems of forces acting in each wall may each be replaced by a single vertical force acting upward at the face of each wall, and a couple whose moment is sufficient to keep the tangent at the wall horizontal.

The beam, under the action of these forces and the loads, may then be considered as a body in equilibrium.

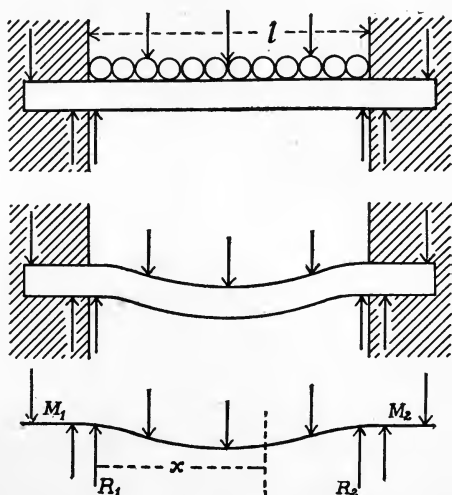

FIG. 66.

From the mechanics of equilibrium of parallel forces, it is evident that the sum of the two vertical forces acting upward must be equal to the sum of the loads on the beam, and if the moments of the couples are determined, the values of the two vertical forces may be found.

Let R_1 (Fig. 66) be the force at the left end and R_2 the force at the right end, and the moments of the couples at the left and right ends of the beam be M_1 and M_2 respectively. Since the moment of a couple about any point is constant, the moment of the couple on the left end about a point in a section distant x from the left end is M_1 , and the value of the bending moment for that section is

$$M = M_1 + R_1x - \frac{wx^2}{2} - \left\{ \begin{array}{l} \text{the sum of the moments} \\ \text{of the loads, etc.} \end{array} \right\}$$

This value of M substituted in $EI \frac{d^2y}{dx^2} = M$ is the differential equation of the elastic curve for a beam fixed at both ends. If there are no concentrated loads, the last term of the expression for M will be zero, and when there is no uniform load, the term containing w will disappear. If there are n concentrated loads, there will be $n + 1$ values for M , and each expression will contain the unknown moment M_1 . The double integration of the $n + 1$ equations will bring into the problem $2(n + 1)$ constants of integration, making $2n + 6$ unknown constants to be determined, as M_1 , M_2 , R_1 , and R_2 are all unknown.

Noting that $R_1 + R_2$ equals the sum of the loads, and that the moments of all the forces must be zero will give two, the values of y and $\frac{dy}{dx}$ being zero at each wall will give four more, the derived values for y and $\frac{dy}{dx}$ in the adjacent expressions for M are equal for values of x under any concentrated load will supply $2n$ equations, the required $2n + 6$ equations may be written. If the loads are symmetrical with the middle of the beam, the solution will be much simplified, as $\frac{dy}{dx}$ is zero at the

middle of the beam, and $R_1 = R_2$ and $M_1 = M_2$. The methods given are general and will completely determine the bending moments or deflections for any restrained beams.

Having fully determined the expression for the values of M and V for any restrained beam, the shear and moment diagrams may be drawn, and the maximum moments as well as the inflection points determined, as for simple beams. The value of x which makes the vertical shear equal zero gives the dangerous section for the beam, and the formula $S = \frac{Mc}{I}$ with the value of M a maximum can be used for all investigations of the strength and safety, as well as the design of restrained beams.

ART. 67. Continuous Beams.

A continuous beam was defined as one having more than two supports.

The supports are assumed to be on the same level and rigid, and the section of the beam uniform.

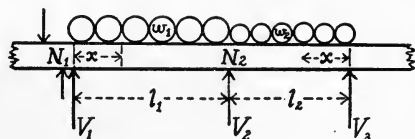

FIG. 67.

Let Fig. 67 represent any two intermediate spans of a continuous beam or girder whose lengths are l_1 and l_2 and loads per linear unit w_1 and w_2 respectively.

There is an unknown bending moment at each support. Let N_1 , N_2 , and N_3 represent these moments.

The moment N_1 is produced by the resultant of all the forces acting to the left of the first support. This resultant and the reaction at the left-hand support may be replaced by a couple whose moment is N_1 and a vertical force V_1 acting at the left-hand support. Evidently V_1 is the sum of the resultant force and the reaction at the left support.

Similarly V_2 , and a couple whose moment is N_2 , and V_3 and a couple whose moment is N_3 , can replace the forces acting at and to the left of the second and third supports.

Taking the origin at the left-hand support and x as any distance in the left-hand span from that support, the equation of the elastic curve for that span becomes

$$EI \frac{d^2y}{dx^2} = M = N_1 + V_1x - \frac{w_1x^2}{2}. \quad (1)$$

Integrating twice and determining the constants by the known conditions that $y = 0$ when x equals either 0 or l_1 ,

$$EI \frac{dy}{dx} = N_1x + \frac{V_1x^2}{2} - \frac{w_1x^3}{6} + C_1 \quad (2)$$

and
$$EIy = \frac{N_1x^2}{2} + \frac{V_1x^3}{6} - \frac{w_1x^4}{24} + C_1x + C_2, \quad (3)$$

$$C_2 = 0 \text{ and } C_1 = \frac{w_1l_1^3}{24} - \frac{N_1l_1}{2} - \frac{V_1l_1^2}{6}.$$

Substituting the value of C_1 in (2),

$$EI \frac{dy}{dx} = N_1x + \frac{V_1x^2}{2} - \frac{w_1x^3}{6} + \frac{w_1l_1^3}{24} - \frac{N_1l_1}{2} - \frac{V_1l_1^2}{6}. \quad (4)$$

Taking the origin at the second support and x as any distance in the second span, the differential equation of the elastic curve for that span becomes

$$EI \frac{d^2y}{dx^2} = M = N_2 + V_2x - \frac{w_2x^2}{2}. \quad (5)$$

Integrating twice and determining constants from the known conditions that $y = 0$ when x equals either 0 or l_2 , we can write

$$EI \frac{dy}{dx} = N_2x + \frac{V_2x^2}{2} - \frac{w_2x^3}{6} + \frac{w_2l_2^3}{24} - \frac{N_2l_2}{2} - \frac{V_2l_2^2}{6}. \quad (6)$$

The values of $\frac{dy}{dx}$ in (4) and (6) are equal when $x = l_1$ in (4) and 0 in (6). (4) reduces to

$$EI \left. \frac{dy}{dx} \right]_{x=l_1} = \frac{N_1 l_1}{2} + \frac{V_1 l_1^2}{3} - \frac{w_1 l_1^3}{8}, \quad (7)$$

and (6) to

$$EI \left. \frac{dy}{dx} \right]_{x=0} = \frac{w_2 l_2^3}{24} - \frac{N_2 l_2}{2} - \frac{V_2 l_2^2}{6}. \quad (8)$$

From (1) $M = N_2$ when $x = l_1$,

$$M = N_2 = N_1 + V_1 l_1 - \frac{w_1 l_1^2}{2}. \quad \therefore V_1 = \frac{N_2 - N_1}{l_1} + \frac{w_1 l_1}{2}. \quad (9)$$

Similarly, from (5) $M = N_3$ when $x = l_2$,

$$M = N_3 = N_2 + V_2 l_2 - \frac{w_2 l_2^2}{2}. \quad \therefore V_2 = \frac{N_3 - N_2}{l_2} + \frac{w_2 l_2}{2}. \quad (10)$$

Equating (7) and (8) and substituting values of V_1 and V_2 from (9) and (10) and reducing, we have

$$N_1 l_1 + 2 N_2 (l_1 + l_2) + N_3 l_2 = - \frac{w_1 l_1^3 + w_2 l_2^3}{4}, \quad (11)$$

which gives the relation between the unknown bending moments N_1 , N_2 , and N_3 , and the uniform loads w_1 and w_2 . One equation similar to (11) may be written for any three consecutive supports, and if n is the number of the supports, $n - 2$ such equations may be written.

When the ends of the beam are merely supported, the moments are N_1, N_2, \dots, N_n , and the values of N_1 and N_n are each equal to zero, so that the $n - 2$ equations that may be written will completely determine the values of the $n - 2$ unknown moments.

When both ends of the beam are to be fixed, the two additional conditions that $\frac{dy}{dx} = 0$ at either end support,

will furnish two more equations that will be sufficient to determine the unknown bending moments at the end supports.

When the values of the bending moments at the supports are determined, the maximum bending moment in any span may be found by writing for the desired span an equation similar to that given for M in (1). The forces V_1 , V_2 , and V_3 are equal to the vertical shears just to the right of the first, second, and third supports respectively. Let R with subscripts 1, 2, and 3 represent the reactions at the corresponding supports. Then for the first support

$$R_1 = V_1.$$

From the definition of vertical shear

$$V_1 - w_1 l_1 + R_2 = V_2 \text{ or } R_2 = V_2 - (V_1 - w_1 l_1). \quad (12)$$

As an equation similar to (12) can be written for any span, the reaction at any support can be determined.

When there are concentrated loads on each span, the discussion is complicated by the fact that there are two or more forms for the equation of the elastic curve for any span instead of only one, bringing into the problem two constants of integration for each concentrated load.

Noting the additional conditions; that the values of $\frac{dy}{dx}$ and y , where two equations meet at the point of application of any concentrated load are equal for the value of x at that point, it is simply a question of algebra to find the relation between the three moments.

The expression as given in equation (11) is known as the Theorem of Three Moments and was published in 1857.

Knowing the reactions and the loads, the shear and moment diagrams may be drawn as for simple beams.

The maximum bending and shearing stresses may be found by using the maximum values of M and V in the fundamental formulas $S = \frac{Mc}{I}$ and $S = \frac{V}{A}$.

The maximum bending moments occur where the shear passes through zero; hence, by writing the expression for the vertical shear and equating it to zero, the position of the maximum moment may be found and its magnitude determined from the equation for the bending moment. Equating the expression for the bending moment to zero will give the point of inflection. The caution given before may well be repeated here :

“When substituting the value of x which renders the vertical shear zero to determine the value of the maximum bending moment, substitute in the particular expression for the value of M that applies to that portion of the beam, and when equating the expression for M to zero in order to find the inflection points, the expression which applies to that portion of the beam must be used.”

As was the case with overhanging beams, the inflection points and the points of zero shear may be approximately located by inspection of the moment and shear diagrams.

The maximum stress in a continuous beam with a number of equal spans may be less than the maximum stress for simple beams for the same spans; hence, when using continuous beams care must be taken to insure that all the supports are on the same level and practically rigid, otherwise the maximum stress may be greater than for a number of simple beams. Take the case of two equal spans with a uniform load of w lb./ft. If the beam is truly continuous, that is the supports on the same level and practically rigid, the maximum unit stress is, $-\frac{1}{8}wl^2$.

This is numerically equal to the maximum moment in a simple beam of the same span.

Suppose the middle support of the continuous beam to sink so that there is no reaction, then the maximum moment is $\frac{1}{8} w 4 l^2 = \frac{1}{2} w l^2$, instead of $\frac{1}{8} w l^2$, or the unit stress will be four times as large as for the simple beam.

As the deflection of beams as used in engineering structures is a very small quantity, the stress may easily approximate this maximum value when the supports do not remain precisely at the same level.

EXAMINATION

What is meant by the expression, "the elastic curve of a beam" ?

Derive the differential equation for the elastic curve of any beam.

Name all the conditions that must be satisfied if the use of the equation will give results that are approximately correct.

What is the "deflection" of a beam ?

Show how the differential equation of the elastic curve may be used to determine the maximum deflection for any beam.

Prove that if the loading of any simple beam is symmetrical with the middle of the beam, $\frac{dy}{dx} = 0$ at that point.

Why is it that when there are n concentrated loads on a beam, the expression for the bending moment may take $n + 1$ different forms ?

Show that the maximum deflections of simple and cantilever beams rectangular in section, and uniformly loaded, vary as $\frac{Sl^2}{d}$ and $\frac{wl^3}{bd^3}$.

What is a restrained beam ?

Why is it that the laws of mechanical equilibrium can not be used to determine the reactions for restrained beams?

Explain how the differential equation of the elastic curve may be used as an aid in the determination of the reactions for restrained beams.

Explain how to find the maximum bending moment for any restrained beam.

Will the maximum bending moment and the maximum deflection always be found at the same point in the beam?

State under what conditions they will be found at the same point.

What is a continuous beam?

State the various steps in the method used in deriving the equation known as "the equation of three moments."

Write "the three-moment equation" for a continuous beam with equal spans and a uniform load on each span.

Show how to find the reactions for a continuous beam after the equation of three moments has been found.

Show that in the case of a continuous beam uniformly loaded the maximum unit stress may accidentally be greater than the maximum unit stress for a number of simple beams, one for each span.

When the size of a beam for a given span has been found on the assumption that the beam was to be fixed at both ends, it is necessary to take precautions to preserve the restraint. Why?

Show that in any uniformly loaded beam, simple, restrained, or continuous, if V is the vertical shear on the right of any left hand support, and N is the bending moment at that support, the maximum bending moment in that span is $M_{\text{Max.}} = N + \frac{V^2}{2w}$, in which w is the uniform load per inch.

PROBLEMS

1. Show that if the depth of a rectangular beam of uniform strength is constant, the elastic curve is a circle.

SOLUTION. We have the relation $\frac{S}{E} = \frac{c}{r}$, from which r is constant when c is constant, but $c = \frac{d}{2}$; hence, r is constant and the curve a circle.

2. Show that if a simple beam carries two equal loads at equal distances from either end of the beam, the elastic curve between the loads is a circle.

3. A simple beam 30 ft. long carries a uniform load of 160 lb./ft. The beam is 4 in. wide and 6 in. deep. Modulus of elasticity 1,600,000. Required, the inclination of the beam with the horizontal at the supports.

SOLUTION. Find the value of $\frac{dy}{dx}$ from the differential equation of the elastic curve; put $x = 0$ and solve.

4. Find the maximum deflection for a simple beam, length l , modulus of elasticity E , moment of inertia I , loaded with

(a) a uniform load of w lb./in.

(b) a single load P at the middle.

SOLUTION FOR (a). The expression for the bending moment at any section of the beam is $M = R_1x - \frac{wx^2}{2}$ and $R_1 = \frac{wl}{2}$; hence $EI \frac{d^2y}{dx^2} = \frac{wlx}{2} - \frac{wx^2}{2}$ is the differential equation of the elastic curve for this beam.

Integrating,

$$EI \frac{dy}{dx} = \frac{wlx^2}{4} - \frac{wx^3}{6} + C; \text{ but } \frac{dy}{dx} = 0 \text{ when } x = \frac{l}{2}, \text{ therefore } C = -\frac{wl^3}{24};$$

and substituting its value, $EI \frac{dy}{dx} = \frac{wlx^2}{4} - \frac{wx^3}{6} - \frac{wl^3}{24}$.

Integrating again,

$EIy = \frac{wlx^3}{12} - \frac{wx^4}{24} - \frac{wl^3x}{24} + C_1$; but as $y = 0$ when $x = 0$, $C_1 = 0$, and the equation of the elastic curve becomes $24EIy = 2wlx^3 - wx^4 - wl^3x$.

Equating the expression for $\frac{dy}{dx}$ to zero, we find that $x = \frac{l}{2}$, $-.365l$, and $1.365l$. The latter values have no meaning for this problem, and y is a maximum when $x = \frac{l}{2}$. Substituting this value for x in the expression will give the value of the maximum deflection.

5. Find the maximum deflection of a cantilever beam, length l inches, modulus of elasticity E , moment of inertia I , loaded with

- (a) a uniform load of w lb./in.
- (b) a single load at the end.

Solve by taking the origin at the wall and measuring x toward the free end; and also at the free end of the beam.

- (c) a single load P , at a distance kl from the wall.

SUGGESTION FOR (c). For any section on the left of P , $M = 0$; hence that part of the beam is straight. The value of $\frac{dy}{dx}$ for $x = kl$ gives the slope of the straight portion. When the deflection under the load is known, the deflection of the end of the beam may easily be found. Take the origin at the wall.

6. A steel cantilever beam rectangular in section is 18 in. in length, and is to carry a load of 1000 lb. at the free end, and deflect .36 in. under that load. The unit stress may be taken as 30,000 lb./sq. in. Find the size of the beam.

7. A beam fixed at one end and supported at the other is l in. long and carries,

- (a) a uniform load of w lb./in.
- (b) a single load P at the middle;

find the expressions for,

- (1) the deflection at any point of the beam.
- (2) the maximum deflection and the point where it occurs,
- (3) the maximum bending moment and where it occurs,

(4) the reaction at the supported end of the beam, and make a sketch showing the form of the shear and moment diagrams.

SOLUTION FOR (a). Taking the origin at the supported end let R_1 be the unknown reaction at the supported end. The value of M at any point of the beam is $M = R_1x - \frac{wx^2}{2}$, as there are no concentrated loads on the beam, and the differential equation of the elastic curve becomes

$$EI \frac{d^2y}{dx^2} = R_1x - \frac{wx^2}{2}. \quad (1)$$

Integrating,
$$EI \frac{dy}{dx} = \frac{R_1x^2}{2} - \frac{wx^3}{6} + C. \quad (2)$$

The tangent at the fixed end is zero, hence $\frac{dy}{dx} = 0$ when $x = l$, and substituting $x = l$ in (2) gives $C = \frac{wl^3}{6} - \frac{R_1l^2}{2}$. Substitute this value of C in (2) and integrate,

$$EIy = \frac{R_1x^3}{6} - \frac{wx^4}{24} + \frac{wl^3x}{6} - \frac{R_1l^2x}{2} + C_1. \quad (3)$$

This equation must be true for $x = 0$ when $y = 0$, therefore $C_1 = 0$. It must also be true for $y = 0$ and $x = l$; making $y = 0$ and $x = l$, (3) becomes

$$EIy]_{x=l} = \frac{R_1l^3}{6} - \frac{wl^4}{24} + \frac{wl^4}{6} - \frac{R_1l^3}{2} = 0, \text{ or } R_1 = \frac{3wl}{8}.$$

Substituting for C_1 and R_1 in (3), we have

$$48 EIy = 3wx^3 - 2wx^4 - wl^3x \quad (3')$$

as the equation of the elastic curve for this beam.

The value of M was $R_1x - \frac{wx^2}{2}$, and as $R_1 = \frac{3wl}{8}$,

$$M = \frac{3wlx}{8} - \frac{wx^2}{2}, \quad (4)$$

$$\text{also } V = R_1 - wx = \frac{3wl}{8} - wx, \quad (5)$$

and from these two equations the shear and moment diagrams may be drawn.

$V = 0$ for $x = \frac{3l}{8}$; therefore the maximum moment occurs at $\frac{3}{8}l$, and this value of x substituted in (4) gives

$$M_{\max.} = \frac{9wl^2}{128}.$$

There will be a negative moment at the wall, and its value can be obtained by making $x = l$ in (4), or

$$M_{x=l} = -\frac{wl^2}{8}.$$

Making $M = 0$ and solving (4) for x gives

$$M = \frac{3wx}{8} - \frac{wx^2}{2} = 0, \text{ or } x = \frac{3l}{4},$$

as the inflection point.

Substituting for C and R_1 in equation (2) gives

$$EI \frac{dy}{dx} = \frac{3wx^2}{16} - \frac{wx^3}{6} + \frac{wl^3}{6} - \frac{3wl^3}{16}.$$

This expression is the differential coefficient of (3); therefore, equating the right hand member to zero and solving for x gives the value of x for which (3) is a maximum. This results in a cubic equation, $8x^3 - 9lx^2 + l^3 = 0$. The roots of this equation are $x = l$, $.42l$, and $-.298l$. The latter value has no meaning for this beam, and $x = l$ is a minimum; therefore the maximum deflection occurs at $x = .42l$.

Substituting $x, .42l$ in (3') gives $y_{\max.} = \frac{.0054wl^4}{EI}$ as the maximum deflection.

SUGGESTION FOR (b). There are two differential equations for the elastic curve and the two curves have a common tangent and common deflection for a value of $x = \frac{l}{2}$.

8. A beam l in. long is fixed at both ends and carries,

(a) a uniform load of w lb./in.,

(b) a single load P at the middle;

find

(1) the expression for the deflection at any point of the beam,

(2) the expression for the maximum bending moment and its position,

(3) the expression for the maximum deflection and where it occurs.

(4) Make a sketch showing the form of the shear and moment diagrams.

SUGGESTION FOR (b). Since the loads are symmetrical with the middle of the beam $M_1 = M_2$ and $R_1 = R_2 = \frac{P}{2}$ and $\frac{dy}{dx} = 0$, when $x = l$, $x = \frac{l}{2}$, and $x = 0$.

9. A rectangular beam, 20 ft. long fixed at both ends carries a uniform load of 100 lb./ft. If the modulus of elasticity is 1,500,000, the safe unit stress is 500 lb./sq. in. and $d = 4b$, find the size of the beam.

10. If the beam in 9 carried a load of 2000 lb. at the middle, and the other data the same, find the size of the beam.

11. Find the maximum deflections for the beams in problems 9 and 10.

12. Draw the shear and moment diagrams for the beams as given in problems 9 and 10.

13. If the beams in problems 9 and 10 were to be beams of uniform strength with a constant depth, sketch the plan and elevation for each beam.

14. Sketch the shear and moment diagrams for the beams in problem 13, using as ordinates the unit shearing stresses instead of the vertical shears, and the unit bending stress instead of the bending moments.

15. Select a standard steel I beam to be used as a continuous girder for four equal spans of 8 ft. each. The ends are simply supported and the beam is to carry a uniform load of 7000 lb./ft. Unit stress not greater than 16,000 lb./sq. in.

SOLUTION. As the ends are supported, $N_1 = N_5 = 0$ and from the symmetry of the spans and loads, $N_2 = N_4$ and $R_1 = R_5$, $R_2 = R_4$.

The three-moment equation for equal loads and spans reduces to

$$N_1 + 4N_2 + N_3 = -\frac{wl^2}{2}. \quad (1)$$

Beginning with the second span,

$$N_2 + 4N_3 + N_4 = -\frac{wl^2}{2}, \quad (2)$$

and with the third span,

$$N_3 + 4 N_4 + N_5 = -\frac{wl^2}{2}. \tag{3}$$

Since $N_2 = N_4$, (2) becomes

$$2 N_4 + 4 N_3 = -\frac{wl^2}{2}, \tag{4}$$

and as $N_5 = 0$, eliminating N_4 from (3) and (4), we find that

$$N_3 = -\frac{wl^2}{14}.$$

Making $N_1 = 0$ and substituting for N_3 in (1),

$$N_2 = -\frac{3wl^2}{28}.$$

For the first span, $V = V_1 - wx$ or $V = 0$ when $x = \frac{V_1}{w}$.

The bending moment for any section of the first span [see equation (1), art. 67] is

$$M = N_1 + V_1x - \frac{wx^2}{2} \text{ and } M_{\max.} = N_1 + \frac{V_1^2}{2w}. \tag{5}$$

Similarly, for the second span $V = V_2 - wx$, or $V = 0$ when $x = \frac{V_2}{w}$,

and as the value of the bending moment for any section in the second span is

$$M = M + V_2x - \frac{wx^2}{2}, \text{ the } M_{\max.} = N_2 + \frac{V_2^2}{2w}. \tag{6}$$

Equations (9) and (10) of Art. 67 give value of V_1 and V_2 . Substituting these values in (5) and (6), we have

$$M_{\max.} \text{ in the first span} = \frac{121}{1568} wl^2 = \text{approx. } \frac{2.1}{28} wl^2,$$

$$M_{\max.} \text{ in the second span} = \frac{57}{1568} wl^2 = \text{approx. } \frac{1}{28} wl^2,$$

and as the moments in the third and fourth spans are the same as in the second and first, the greatest moment occurs at the second support and is $\frac{3wl^2}{28}$, which may be written $\frac{3Wl}{28}$, where W is the total load on one span.

Substituting this value of M in $\frac{M}{S} = \frac{I}{c}$, we find the value of $\frac{I}{c}$ as 36 in.³.

From the tables we find that a 12-in. I beam weighing 31.5 lb./ft. has a value of $\frac{I}{c} = 36$, and that beam will be chosen.

16. I beams are to be chosen to cover two equal spans of 10 ft. each. The uniform load for each span is 5000 lb./ft. and the maximum allowable unit stress is 15,000 lb./sq. in. Choose a standard I beam on the assumption that the beam is continuous. What beam must be used if two simple beams are used instead?

17. Select a standard steel I beam to cover three spans of 8 ft. each and carry a uniform load of 7000 lb./ft. The unit stress is not to exceed 16,000 lb./sq. in. What size beam would it be necessary to use if each span was covered by a simple beam? How much weight of steel will the use of continuous beams save?

18. In problem 17 find the reactions at the supports for each kind of a beam.

19. Select a continuous steel I beam to cover two equal spans of 12 ft. each, and carry a load of 36,000 lb. at the middle of each span. Unit stress 12,000 lb./sq. in.

SUGGESTION. There are four forms of the differential equation of the elastic curve, each two having a common tangent and deflection at the load or reaction where they meet. The three reactions are all unknown but $R_1 = R_3$, and there is an unknown bending moment at R_2 , the middle reaction.

CHAPTER VI

LONG COLUMNS

ART. 68. Stresses in Long Columns.

A theoretical bar under the action of axial compression should always yield by crushing, since the resultant of the stresses and the axial loads are in the same line. In dealing with the actual materials and loads, the force due to the load is not always axial, no matter how much care is taken to make it so, and no material in common use is absolutely uniform. In nearly every case of bars under axial compression, there is more or less of a couple caused by the bar not being straight and uniform in structure, or the loads not axially applied.

The effect of this couple is to produce bending in the bar. As the amount of bending or deflection of a beam under the action of bending forces varies directly with the cube of the length, it is easy to see that the danger of bending a bar under the action of compressive forces which are not exactly axial, increases very rapidly with the length, and also that any bending increases the moment of the axial forces.

Experiment has proven that when the length of the bar does not exceed ten times its least dimension, it is more liable to fail by crushing, than by bending and crushing combined.

Therefore, when the length of a bar under axial compression does not exceed ten times the least dimension, the formula $P = AS$ may be used to determine the relations between the load and unit stresses.

Such a bar is called a short column or strut. When the length of the bar exceeds this limit, it is called a long column; and as the stress which is a combination of bending and compressive stresses is not uniformly distributed over the area of the cross section, the formula $P = AS$ no longer applies.

Since the amount of the bending stress in a long column is due entirely to the imperfections of the material and the eccentricity of the loads, there can be no strictly theoretical formula developed for the determination of such stresses.

There are two formulas in general use expressing the relation between the load and the dimensions of a long column: Euler's formula for long columns, which is derived from theoretical considerations, gives the relation between the load and the elastic resistance of the column, taking no account of the unit stress induced; and Rankine's formula, which gives a relation between the loads and the unit stress induced, while theoretical in form, contains an empirical constant.

ART. 69. Euler's Formula.

This is the oldest discussion of the theory of long columns, and was offered by Euler in 1757.

He assumed:

- 1st, that the column was perfectly straight,
- 2d, that the loads were axially applied at the center of gravity of the cross section,
- 3d, that the material was uniform in density.

Such a column would never bend under any load, but would fail by crushing. To produce incipient bending he assumed a slight lateral force to be exerted against the column while it was under the axial load, and determined the value of the axial load P that would keep the column bent after the lateral force was removed.

The elastic curve of a bent column may take any one of several forms, depending on the condition of the ends.

ART. 70. Columns with "Round" or "Pin" Ends.

If the ends of the column are designed so that there will be no restraint to the tendency to rotation about a point on the end, the column is said to have "Round" or "Pin" ends. If the ends are rounded as in Fig. 70, it will bend in a single curve, and the elastic curve may be represented as in the figure.

Taking the origin at O , the moment of P about a point in any section distant x from O is $M = Pa - Py$, and the equation of the elastic curve for this case is

$$EI \frac{d^2y}{dx^2} = Pa - Py. \quad (1)$$

Multiplying by $\frac{2}{dx} \frac{dy}{dx}$ and integrating with respect to y ,

$$EI \left(\frac{dy}{dx} \right)^2 = 2Pay - Py^2 + C_1. \quad (2)$$

Evidently $\frac{dy}{dx}$ is 0 when $y = 0$, hence $C_1 = 0$.

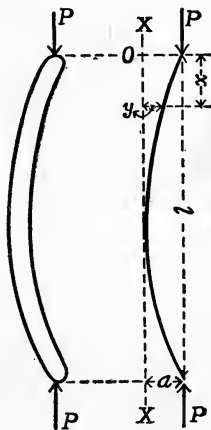

FIG. 70.

Extracting the square root and transposing,

$$dx = \sqrt{\frac{EI}{P}} \frac{dy}{\sqrt{2ay - y^2}}; \quad (3)$$

integrating,

$$x = \sqrt{\frac{EI}{P}} \operatorname{vers}^{-1} \frac{y}{a} + C_2. \quad (4)$$

When $x = 0$, then $y = a$ and $\operatorname{vers}^{-1} \frac{y}{a} = \frac{\pi}{2}$,

hence $C_2 = -\frac{\pi}{2} \sqrt{\frac{EI}{P}}$.

Also when $x = \frac{l}{2}$, $y = 0$, and $\operatorname{vers}^{-1} \frac{y}{a} = 0$,

hence $\frac{l}{2} = -\frac{\pi}{2} \sqrt{\frac{EI}{P}}$, or $P = \frac{EI\pi^2}{l^2}$,

which gives the value of the load P that will keep a column with round ends bent, *after the lateral force has been removed*. As the deflection y has disappeared from the expression for P , its value is independent of the amount of bending.

ART. 71. Columns with Square, Flat, or Fixed Ends.

When the column is so designed that the tangent to the elastic curve at each end will be parallel to the length of the column, the column is said to have square, flat, or fixed ends. A column of this type may have a cap, which on account of the large surface it presents, tends to prevent free bending about a point in that end, or it may

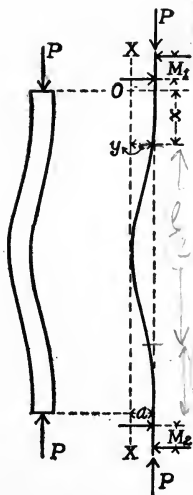

FIG. 71.

have the ends firmly imbedded in masonry. The form that the elastic curve takes in this case is similar to that of a beam fixed at both ends when there is a single load at the middle of the span. Let Fig. 71 represent a column with fixed ends as bent by the load P . The moments that keep the ends of the column vertical being denoted by M_1 and M_2 , the moment due to M_1 and the load P , at any section of the column distant x from O , is

$$M = M_1 + Pa - Py,$$

and the equation of the elastic curve is

$$EI \frac{d^2y}{dx^2} = M_1 + Pa - Py. \quad (5)$$

Reducing as before and integrating,

$$EI \left(\frac{dy}{dx} \right)^2 = 2 M_1 y + 2 Pay - Py^2 + C_3, \quad (6)$$

when $y = 0$, $\frac{dy}{dx} = 0$, and C_3 becomes zero, also when $y = a$, $\frac{dy}{dx} = 0$, and the value of M_1 is found to be $-\frac{Pa}{2}$.

Inserting these values in (6), taking square roots, and transposing,

$$dx = \sqrt{\frac{EI}{P}} \frac{dy}{\sqrt{ay - y^2}}. \quad (7)$$

Integrating (7), we have

$$x = \sqrt{\frac{EI}{P}} \text{vers}^{-1} \frac{2y}{a} + C_4. \quad (8)$$

Here $x = 0$ when $y = a$;

hence $\text{vers}^{-1} \frac{2y}{a} = \pi$, and $C_4 = -\pi \sqrt{\frac{EI}{P}}$;

also when $x = \frac{l}{2}$, $y = 0$, therefore $\text{vers}^{-1} \frac{2y}{a} = 0$.

Inserting these values in (8), we have

$$\frac{l}{2} = -\pi \sqrt{\frac{EI}{P}}, \text{ or } P = 4 \frac{EI\pi^2}{l^2},$$

which is Euler's formula for columns with fixed ends.

ART. 72. Columns with Round and Square Ends.

When one end of a column is restrained so that the tangent to the elastic curve at that end is always vertical, and the other end is left free to rotate about a point in that end, the column is said to be one with round and square ends.

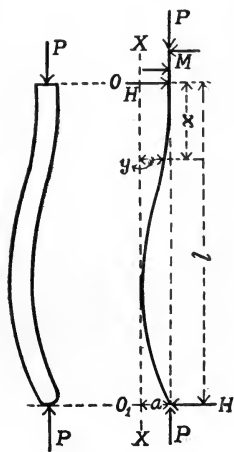

FIG. 72.

The elastic curve will take some such form as shown in Fig. 72.

Taking the axis of X as vertical and the origin at the upper end of the column, if M_1 is the moment that keeps the tangent vertical, the moment due to M_1 and that of the force P about a point in any section of the column distant x from the upper end, is $M = M_1 + Pa - Py$, and the

equation of the elastic curve becomes

$$EI \frac{d^2y}{dx^2} = M_1 + Pa - Py. \quad (9)$$

Equation (9) is the same form as (5), and as the conditions to be satisfied are the same with the exception that $\frac{dy}{dx}$ does not become zero when x equals $\frac{l}{2}$, we may write

$$x = \sqrt{\frac{EI}{P}} \text{ vers }^{-1} \frac{2y}{a} - \pi \sqrt{\frac{EI}{P}}. \quad (10)$$

Taking the origin at the lower end of the column, measuring x up from O_1 , and remembering that the value of the bending moment for one end of the column is the same as that for the other end with the sign changed, we may write

$$EI \frac{d^2 y}{dx^2} = Pa - Py. \quad (11)$$

This is of the same form as equation (1); therefore

$$x = \sqrt{\frac{EI}{P}} \operatorname{vers}^{-1} \frac{y}{a} - \frac{\pi}{2} \sqrt{\frac{EI}{P}}. \quad (12)$$

If b and d are two such numbers that $\frac{l}{b} + \frac{l}{d} = l$, then equations (10) and (12) are equal when $x = \frac{l}{b}$ in (10) and $x = \frac{l}{d}$ in (12), and when they are equal, $y = 0$.

Equating (10) and (12) and making $y = 0$, we have

$$\left(\sqrt{\frac{EI}{P}} \frac{\pi}{2} \right) b = d \sqrt{\frac{EI}{P}} \pi, \text{ whence } b = \frac{3}{2} \text{ and } d = 3.$$

Substituting $x = \frac{2l}{3}$ and $y = 0$ in equation (10), we have

$$\frac{2l}{3} = -\pi \sqrt{\frac{EI}{P}}, \text{ or } P = \frac{9}{4} \frac{EI\pi^2}{l^2}, \quad \text{approx } P = \frac{2EI}{l^2}$$

as the formula for columns with round and square ends.*

* The column is not in equilibrium for this case unless a couple H-H. (see Fig. 72) is introduced. Considering this couple and taking the origin at the round end of the column, the equation of the elastic curve becomes

$$EI \frac{d^2 y}{dx^2} = Pa - Py + Hx,$$

which reduces to $P = 2 \frac{EI\pi^2}{l^2}$ (nearly), instead of $\frac{9}{4} \frac{EI\pi^2}{l^2}$. The approximate solution has been offered because the value of P as usually given is

$$\frac{9}{4} \frac{EI\pi^2}{l^2}.$$

In the solution of problems by the use of these formulas, I is always the moment of inertia about a gravity axis *perpendicular to the direction of bending*. If the column is free to bend in any direction, the *least* value of I for that section must be used. E is the modulus of elasticity, and as the tabulated values are in inch pounds, P must be expressed in pounds and l and I in inches. It will be noticed that the formulas for the three types of long columns differ only by a constant.

If the strength of a column is defined as the load it will carry, and the strength of a column with square ends is taken as unity, it is easily shown that the strengths are as:

1 for a column with square ends,

$\frac{1}{4}$ for a column with round ends,

$\frac{9}{16}$ for a column with round and square ends.

Ar^2 may be substituted for I in the general formula for long columns and the formula written

$$\frac{P}{A} = m \frac{r^2 E \pi^2}{l^2},$$

where m has values of 1, 4, $\frac{9}{4}$, according to the condition of the ends of the columns, and r is the least radius of gyration.

The ratio of the length to the least value of the radius of gyration is called the "slenderness ratio" of a column, and when this ratio is greater than 25, the column may be considered as a long column.

If the stress was uniformly distributed over the section of the column, the value of $\frac{P}{A}$ would be the unit stress.

Taking $\frac{P}{A}$ as the unit stress, $m = 1$, $\pi^2 = 10$, and the ratio of $\frac{l}{r} = 100$, the value of S for a wrought iron column

is 25,000 lb./sq. in., which is practically the elastic limit of the material.

If $\frac{l}{r}$ is taken as 50, the value of S becomes greater than the ultimate strength of the material.

As the majority of columns in engineering structures have the ratios of $\frac{l}{r}$ from 50 to 150, it is plain that Euler's formula will not always give satisfactory results. The results of experimental work on long columns show that the formula can not be depended on unless the ratio of $\frac{l}{r}$ is nearly 200.

Euler's formula not being satisfactory for the usual range of the values of $\frac{l}{r}$ has led to the adoption of a formula, first proposed by Gordan and later modified by Rankine.

Rankine's modification of Gordan's formula is in common use among American engineers, while the European engineers prefer Euler's formula or some modification of it.

If Euler's formula is used for the design of a long column, the resulting dimensions should be checked by the formula for axial compression to determine the value of the unit stress.

ART. 73. Rankine's Formula.

This formula is based on the assumption that the maximum unit stress in any section of a long column under axial compression is a *combination of the compressive unit stress due to the axial compressive force and the maximum unit bending stress due to the probable moment of the same force.*

Let S_c be the maximum unit compressive stress in any section of a long column, $S_1 = \frac{P}{A}$ be the unit compressive stress due to the load P , $S_2 = \frac{Mc}{I}$ the maximum unit compressive stress due to the probable moment of the axial force, and A the area of the section of the column; then

$$S_c = S_1 + S_2 \text{ or } S_c = \frac{P}{A} + \frac{Mc}{I}, \quad (1)$$

from which the maximum unit stress S_c may be found when $\frac{P}{A}$ and $\frac{Mc}{I}$ are known. The value of $\frac{P}{A}$ may easily be found, but the value of $\frac{Mc}{I}$ is indeterminate, owing to the lack of knowledge of the probable eccentricity of the force P .

If we assume that f is the maximum deflection due to the unknown moment M , the value of that moment may be expressed as Pf . Writing Ae^2 for I and making $M = Pf$, equation (1) reduces to

$$S_c = \frac{P}{A} \left(1 + \frac{fc}{e^2} \right). \quad (2)$$

By analogy with beams where the maximum deflection varies as $\frac{l^2}{c}$, f may be taken as proportional to $\frac{l^2}{c}$. If ϕ is some number depending on the material of the column for its value, and n is a number whose value depends on the conditions at the ends of the column, then $f = n\phi \frac{l^2}{c}$. Substituting this value of f in equation (2), we have

$$S_c = \frac{P}{A} \left(1 + n\phi \frac{l^2}{e^2} \right), \text{ or } P = \frac{AS_c}{1 + n\phi \frac{l^2}{e^2}}, \quad (3)$$

eg. $\frac{f}{A} = \frac{10000}{1 + 10000 \frac{l^2}{e^2}}$

which is Rankine's formula for the solution of problems relating to long columns. Since S_c is usually given in pounds per square inch, P must be expressed in pounds, and l and r in inches. The value of r to be used will depend on the direction in which bending takes place. If there is no external restraint to bending, the *least* value of r for the section considered must be used. The value of ϕ has to be determined by experimental work on long columns. The method generally taken to determine the value of ϕ is to find by experiment the load that will cause the column to fail, and substitute that value for P in Equation (3). S_c is taken as the ultimate compressive strength of the material and, as n , l , A , and r are all known, the value of ϕ can be found. The reliability of the formula depends on the accuracy with which the value of ϕ is determined. The following table gives the usual value of ϕ as found for columns where the ratio of $\frac{l}{r}$ varied from 20 to 200, and therefore can be applied to problems where the ratio of $\frac{l}{r}$ is within these limits.

For hard steel	$\phi = \frac{1}{200000}$;
for mild steel	$\phi = \frac{1}{300000}$;
for wrought iron	$\phi = \frac{1}{360000}$;
for cast iron	$\phi = \frac{1}{64000}$;
for timber	$\phi = \frac{1}{30000}$.

The strengths of columns of the same dimensions with square, round, and round and square ends were found to be in the ratio of 1, $\frac{1}{4}$, and $\frac{9}{16}$ respectively.

The strengths of the columns also varied inversely as l^2 .

Let l_1 , l_2 , and l_3 be the lengths of three columns having equal section areas and ends square, round, and round and

square respectively; then $l_1 = 2l_2$, where each column has the same strength. Under the same conditions, $l_1 = \frac{4l_3}{3}$. Writing Rankine's formula $P = \frac{AS_c}{1 + \phi \frac{l^2}{r^2}}$, and making l equal

to l_1 , $2l_2$, and $\frac{4l_3}{3}$, successively, there will result a numerical coefficient for the last term in the denominator of 1, 4, $\frac{16}{9}$. In Equation (3) n was a number depending for its value on the conditions at the ends of the columns, hence n must equal 1 for columns with square ends, 4 for columns with round ends, and $\frac{16}{9}$ for columns with round and square ends.

As this constant n depends on the condition of the ends of the columns, and that condition determines the form that the elastic curve assumes, it is evident that n should bear some relation to the deflections of beams having similar elastic curves.

Compare the maximum deflection of a simple beam carrying a concentrated load at the middle with the maximum deflection for a beam with both ends fixed carrying the same load.

The elastic curve for the simple beam is similar to that for a column with round ends, and the deflection is four times as large as the deflection for the restrained beam, whose elastic curve resembles that for a column with both ends fixed. Therefore the value of n for a column with round ends should be four times that for a column with square ends. This agrees with the value derived from the assumptions of relative strengths.

ART. 74. Applications.

In the use of Rankine's formula the value of S_c may be taken as the safe working unit stress, and then P will be the load that can be carried with safety. P is always less than S_c , as $1 + n\phi \frac{l^2}{r^2}$ is always greater than unity; hence, no matter how short a column may be, Rankine's formula will give a safe value for P when the safe value of S_c is used. Since $n\phi$ is a small quantity, if the ratio of $\frac{l}{r}$ is small, $1 + n\phi \frac{l^2}{r^2}$ may be practically unity and the value of P very nearly equal to AS_c . The value of ϕ being derived from experiment, the formula is limited in its use to the range in the values of $\frac{l}{r}$ covered by the experimental work in its determination. The values of ϕ , as given, apply very well to all columns where the ratio of $\frac{l}{r}$ lies between 20 and 200. Above this ratio the load given by Rankine's formula will still be safe, as the formula gives the value of P too small. On the other hand, Euler's formula gives values for P that are too large when the ratio of $\frac{l}{r}$ is less than 150, and the load given does not agree well with practice till the ratio approaches 200.

The forces producing tensile, compressive, and bending stresses are all determinate, and the results given by the formulas for these stresses agree very well with those determined experimentally. The formula for the maximum unit stress in a long column contains the effect of an indeterminate bending moment, the actual stress depending on the magnitude of that moment. As no general assump-

tions can be made as to the probable value of the moment, the allowable working stress in long columns is always taken less than for the same materials under other forms of stress. Many other formulas, some of them entirely empirical and others more or less theoretical, have been proposed, but none have come into general use. For a full discussion of the various formulas the student is referred to "Text-book on the Mechanics of Materials," Merriman.

Cast iron columns are common in engineering work on account of the large compressive strength of the material. As long as the unit stress due to the bending does not equal the unit compressive stress due to the load there is no tensile stress in the column. The columns are generally made hollow and round in section.

Wrought iron and steel pipes are also often used for columns. The values of I or r may be found as soon as the internal and external diameters are known.

Rolled steel shapes, in channel and I beams, are joined together by plates, which are riveted to them, and used as columns. Timber is used in the solid section and in the hollow box section. In the case of circular sections the value of I is the same for bending in all directions. When the column is "built" up, as is the case when the rolled steel shapes are used with the joining plates, the spacing should be such that the values of I for the "built" section will be equal about the two principal axes. The same is true of the wooden box sections. For the rolled steel shapes the value of I for the gravity axes of the rolled section, parallel and perpendicular to the web, are given in the tables, and must be transferred to parallel axes passing through the

center of gravity of the built section. For the sections where the elements are rectangular the value of the gravity moment of inertia is $\frac{bd^3}{12}$, where d is the dimension perpendicular to the axis.

Although it involves considerable arithmetical and algebraic work, the process of determining the values of I for the "built" sections is simple.

Given the moment of inertia of any area about an axis passing through the center of gravity of the area, as I_g , the moment of inertia of the area about any parallel axis, distant h , is $I = I_g + Ah^2$.

Having transferred all the gravity moments of inertia to a set of axes passing through the center of gravity of the built section, the sum of the moments with reference to either axis should be equal, and in case they are unequal, the *least value* should be chosen for use in the long column formulas.

EXAMINATION

Explain why the formula $P = AS$ does not give results that agree with experiment when the bar under axial compression is very long.

Define a Long Column.

What assumptions were made when the formula $P = m \frac{EI\pi^2}{l^2}$ was derived?

What is meant by the expression "a column with round ends"? "a column with square ends"? "a column with round and square ends"?

Derive Euler's formula for long columns with square ends; with round ends.

Explain why the formula as derived for columns with round and square ends is approximate.

Explain why the use of Euler's formula for long columns does not always give satisfactory results.

Give the conditions under which the use of Euler's formula for long columns will give satisfactory results.

State the assumptions that were made for the derivation of Rankine's formula for long columns.

Derive Rankine's formula for the strength of long columns.

State the meaning of each symbol and the units to be used in making substitutions in the following formulas:

$$\frac{P}{A} = \frac{Er^2\pi^2}{l^2} \quad \text{and} \quad \frac{P}{A} = \frac{S_c}{1 + n\phi\frac{l^2}{r^2}}$$

Does Rankine's formula for long columns give results that are more reliable than Euler's? Why?

On what does the reliability of Rankine's formula depend?

The formula $S = \frac{Mc}{I}$ was used in the derivation of Rankine's formula for long columns. Does this fact limit the use of the formula to materials which satisfy the conditions for the use of the formula $S = \frac{Mc}{I}$?

Show by the use of Euler's formulas that the strength of a column with square ends being taken as unity, the strength of a column of the same size with round ends is $\frac{1}{4}$ and that of a column with round and square ends is $\frac{9}{16}$.

Explain why the value of n in Rankine's formula is

1 for a column with square ends

4 for a column with round ends, and

$\frac{16}{9}$ for a column with round and square ends.

Show that Rankine's formula applied to the solution for any column, no matter how short, will always give a safe load for that column. Is the same true for Euler's formula?

Is there any limit to the length of a column to which Rankine's formula will apply?

Why is the ratio of $\frac{l}{r}$ used as limiting the use of either formula?

If the section of a column is a rectangle having one side 4 in. and the other 6 in., find the values of I and r to be used in the formulas for the strength of long columns.

Why will a hollow cylindrical form make a stronger column than a solid cylinder of the same section area?

Given the moment of inertia about an axis through the center of gravity, how can you find the moment of inertia of the section about an axis parallel to the gravity axis?

PROBLEMS

1. A wooden column 10 ft. long is rectangular in section and has round ends. The sides of the rectangle are 6 and 8 in. respectively. What is the maximum load the column will carry?

Find the safe load. (Use Euler's formula.)

SOLUTION. The formula is $P = \frac{EI\pi^2}{l^2}$, $I = \frac{bd^3}{12} = \frac{8 \times 6^3}{12} = 144$, since the least moment of inertia must be used.

E may be taken as 1,500,000 and π^2 used as 10. $l = 120$ in.

Substituting,

$$P = \frac{1,500,000 \times 144 \times 10}{14,400} = 150,000 \text{ lb.}$$

This is the greatest load that can be carried without failure by bending. The corresponding unit stress due to the axial force P is $\frac{P}{A} = \frac{150,000}{48} = 3130$ lb./sq. in., or a stress about one half the ultimate strength of the material. In order to carry this load the column must be straight and the load axial. As these conditions are rarely ever satisfied, a factor of safety of at least 5 should be applied to the result. Using this factor, the safe load is 30,000 lb. and produces an axial unit stress of approximately 600 lb./sq. in., which has a fair margin for safety.

2. If the column in problem 1 was cast iron and had square ends, determine the maximum load it will carry and the unit stress induced by that load. Is it possible for the column to carry the load?

3. Show that a cast iron column with square ends must have the ratio of $\frac{l}{r}$ approximately 90 in order that the axial unit stress corresponding to the load P in Euler's formula shall be less than the ultimate compressive strength of the material.

4. If the axial unit stress produced by a force equal to the value of P as derived by Euler's formula is equal to the elastic limit of mild steel, find the ratio of $\frac{l}{r}$ for the column. Consider the ends round; square; and round and square.

5. A standard 12 in. I beam weighing 35 lb./ft. is to be used as a column with round ends. The length is 10 ft. What load may be carried with a factor of safety of 5? If there should be a factor of 5 used with the formula for axial compression, is the load given by Euler's formula safe?

6. A cast iron column 20 ft. long has a hollow circular section. The external diameter is 10 in. and the internal diameter is 8 in. Determine the value of the maximum load that can be carried, if the allowable unit stress for axial compression is 4000 lb./sq. in. What will be the factor of safety against failure by bending? (Column has square ends.)

7. Solve problem 1 by the use of Rankine's formula.

SOLUTION. The formula is $P = \frac{AS_c}{1 + 4\phi \frac{l^2}{r^2}}$, $A = 48$ sq. in., $\phi = \frac{1}{3000}$,
 $S_c = 10,000$ lb. / sq. in. for a maximum load, $r^2 = \frac{I}{A} = \frac{144}{48} = 3$, $l = 120$

in. Therefore $\frac{l}{r^2} = 4800$, and substituting these values,

$$P = \frac{48 \times 10,000}{1 + \frac{4}{30000} 4800} = 65,000 \text{ lb.}$$

Comparing the results obtained from the solution by the two formulas, we see that the allowable load from the former is about twice that obtained by the use of Rankine's formula. Therefore a factor of safety of 5 on Rankine's formula is equal to using a factor of 10 with Euler's formula.

8. Find the size of a circular wooden column 12 ft. long to carry a load of 50 tons with a unit stress of 1200 lb./sq. in. Column has square and round ends.

9. A wooden column 15 ft. long has a box section as shown in the figure. Find the value of x so that the column will carry the greatest load possible.

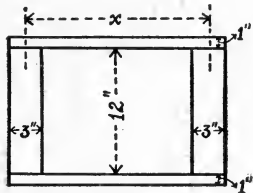

PROBLEM 9.

10. If the safe unit stress for the column as given in problem 9 is 1000 lb./sq. in., find the safe load for the column.

11. Two standard 12-in. channel beams are to be used for a column. The channels are to be placed as shown in the figure and joined by lattice work. If the moment of inertia of the lattice work is neglected, find the distance between the channels so that the column will carry the largest load possible. The column is to have square ends.

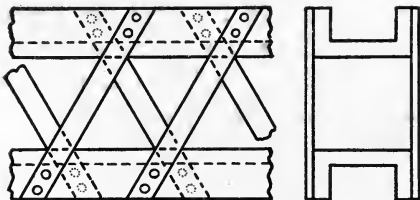

PROBLEM 11.

12. If the safe unit stress in the column given in problem 11 is 12,000 lb./sq. in., find the safe load.

13. A cast iron column 20 ft. long has a hollow circular section. The internal diameter is 8 in. and the external diameter is 10 in. Required the load that may be carried when the maximum unit stress in the column does not exceed 4000 lb./sq. in. (the column has square ends). Compare the result with that obtained from problem 6.

14. The connecting rod for a steam engine has pins at either end that are parallel to each other. When bending tends to take place in a direction perpendicular to the axis of the pins the rod acts as a column with round ends. When the bending tends to take place in a plane through the axis of the pins the rod becomes a column with square ends. If the section of the rod is rectangular, find the relation between the depth and breadth, so that the column may be equally safe against bending in either direction. (Use Euler's formula.)

15. A cast iron column 20 ft. long has a hollow circular section 12 in. outside diameter. The allowable unit stress is 10,000 lb./sq. in. and the load is 50 tons. Required the inside diameter of the column. Consider the column to have square ends.

16. A standard 12-in. I beam 40 ft. long has braces along the web that prevent bending in a direction perpendicular to the web. If S_c is 12,000 lb./sq. in., find the safe load for the column. Column has square ends.

CHAPTER VII

COMBINED STRESSES

ART. 75. Stresses due to Force.

When a force acts on any material, more than one kind of stress may be produced in any fiber of the material. In the previous chapters it was assumed that only one kind of stress resulted from the application of the force, and the magnitude of the stress calculated on that assumption. While this latter condition may be true in some cases, the force acting on a bar often produces two or more kinds of stress. These stresses when combined may result in a maximum unit stress greater than either of the original unit stresses. Any fiber of a beam has a tensile or compressive unit stress due to the bending moment, and a unit shearing stress due to the vertical shear. A shaft carrying a pulley between two supporting bearings is a beam and a torsion bar combined. Each fiber has a unit stress due to the bending, a unit shearing stress due to the vertical shear, and a unit shearing stress due to the twisting moment transmitted through the shaft.

ART. 76. Tension or Compression combined with Bending.

When a bar is subjected to a force whose line of action is parallel to the axis of the bar, it was shown that this force could be replaced by an axial force and a couple.

The axial force produces either tension or compression, and the couple both tension and compression. In such a case, an approximate solution for the problem of finding the value of the combined stress is obtained by combining the tension or compression resulting from the couple, and the tension or compression due to the axial force. Let S_1 be the maximum unit stress due to both sets of force, S be the unit tensile or compressive stress resulting from the axial force, and S_b the tensile or compressive unit stress due to bending, then $S_1 = S_b + S$, where $S_b = \frac{Mc}{I}$ and $S = \frac{P}{A}$ are both tensile or compressive stresses.

When the axial force is a tensile force, the maximum stress found in this way is too large, as the axial force on the bent beam produces a moment Py that tends to reduce the bending moment of the flexural forces. See Fig. 76. When the axial force produces compression, the moment Py of the axial force tends to increase the bending of the bar, and the approximate solution gives the resultant unit stress too small. As the error is due to the moment Py , when the deflection is small the error is also small. While the engineer as a rule desires to be as nearly accurate in his calculations as possible, when the approximate formula is simple and errs on the side of safety, it is often used in preference to the more exact and complicated formula. A bar is often designed to resist a combination of compression and bending stress by the use of the approximate formula, but when this is done the resulting dimensions should be used in a more exact expression and the actual unit stress determined.

Let Fig. 76 represent a beam under the action of flexural and axial forces. Let M be the maximum mo-

ment of the flexural forces, P an axial force which may be either tensile or compressive, f_1 the maximum deflection of the beam.

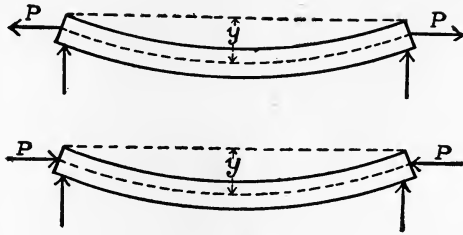

FIG. 76.

If M_1 and S_1 are the maximum bending moment and unit stress due to the sum of the moments M and Pf_1 , then $S_1 = \frac{M_1 c}{I} = \frac{(M \mp Pf_1) c}{I}$, the positive sign being used when P is a compressive force, and the negative sign when P produces a tensile stress. By analogy with beams under the action of flexural forces only, the value of f_1 may be assumed to be $f_1 = \frac{\alpha l^2 S}{\beta E c}$, and the substitution of this value in the equation for S_1 gives

$$S_1 = \frac{M c}{I} \pm \frac{\alpha S_1 P l^2}{\beta E I} \quad \text{or} \quad S_1 = \frac{M c}{I \pm \frac{\alpha P l^2}{\beta E}}$$

The maximum unit stress is $S_1 + \frac{P}{A} = S$, where S_1 has the value as just found. S is either tension or compression, depending on the kind of stress represented by $\frac{P}{A}$. The values of α and β for various kinds of beam and loadings are given in the appendix. There are no values that apply strictly to this case, as the bending moment is increased by the value of the moment Pf_1 . Since f_1 is a small quantity, the error made in assuming that the values of α and β are those found for beams under

flexural forces only is very small, hence α and β will be determined by the kind of a beam and the nature of the loading. The unit stress due to the effect of the two moments is

$$S_1 = \frac{Mc}{I \pm \frac{Pl^2}{E} \frac{\alpha}{\beta}},$$

while that due to the flexural forces only is $S_b = \frac{Mc}{I}$. The difference is

$$S_1 - S_b = \frac{Mc \frac{Pl^2 \alpha}{E \beta}}{I \left(I \pm \frac{Pl^2 \alpha}{E \beta} \right)}.$$

This difference divided by the value of S_1 and multiplied by 100 is the percentage error in the bending unit stress when S_b is used instead of S_1 . The value of this error is $\pm \frac{Pl^2 \alpha}{EI \beta} 100$, from which the per cent of error may be easily found. As the amount of the error depends directly on the value of P , and inversely on E , when P is small, and E large, the error will be so small that it may be neglected. The error also varies directly as l^2 ; therefore it is more liable to be serious when l is large.

For a timber beam 20 ft. long, 6 in. wide, and 12 in. deep, carrying a load of 8000 lb. at the middle and at the same time a compressive load of 45,000 lb., the use of the approximate formula will result in an error of approximately 8 per cent.

For a steel I beam, 10 ft. long, having a moment of inertia of 122, a concentrated load of 6000 lb. at the middle and an axial compressive force of 20,000 lb., the values of S_1 and S_b differ by less than one per cent, an error too small to be taken into account.

ART. 77. Roof Rafters.

The common roof rafter is an example of a beam under axial and bending forces. As a part of a truss there is some compression in the rafter, and the weight of the roof and the probable snow load produce both bending and compression.

Let Fig. 77 represent a roof rafter, length l in., carrying a uniform load of w lb. in. The rafter is in equilibrium under the horizontal forces H_1 and H_2 , V acting vertically at the wall, and the uniform load.

$$H_1 l \sin \phi = \frac{wl^2}{2} \cos \phi,$$

from which

$$H_1 = \frac{wl}{2} \cot \phi.$$

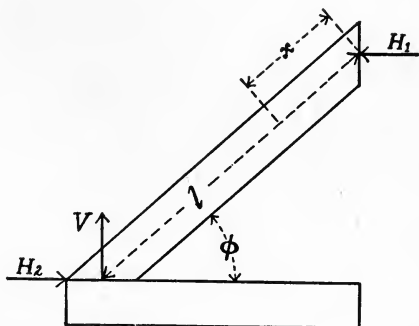

FIG. 77.

The bending moment of the force

H_1 about a point in a section distant x from the upper end of the rafter is $H_1 x \sin \phi$, while that for the uniform loads on the left of the same section is $\frac{wx^2}{2} \cos \phi$. The unit stress due to the bending forces is

$$S_b = \frac{Mc}{I} = \frac{(Hx \sin \phi - \frac{1}{2} wx^2 \cos \phi)c}{I}.$$

The compressive force on the same section is $H_1 \cos \phi$ due to the force H_1 , and $w x \sin \phi$, due to the uniform loads on the section. Hence the total compressive stress in the section is

$$\frac{P}{A} = \frac{(H \cos \phi + wx \sin \phi)}{A}.$$

Using the approximate formula, the maximum unit stress is

$$S = \frac{P}{A} + S_b = \frac{(H \cos \phi + wx \sin \phi)}{A} + \frac{(Hx \sin \phi - \frac{1}{2} wx^2 \cos \phi)c}{I}$$

$\frac{wl}{2} \cot \phi$ may be substituted for H and the value of x that makes S a maximum found. Using this value of x , the value of the maximum unit stress in the rafter may be calculated. If the rafter carries a single concentrated load at the middle, the maximum compression and bending stresses occur at the middle and the maximum stress is easily found.

When there are several concentrated loads on the rafter, the greatest unit stress will have to be found by trial. The compression between any two loads is constant; therefore, the maximum unit stress between any two loads will occur at the point of maximum bending moment between the loads. The maximum stress in several sections may have to be found to determine the greatest unit stress in the rafter.

ART. 78. Eccentric Axial Loads.

When a beam is to resist axial as well as flexural forces, it is nearly always possible to make the point of application of the axial force so that the moment about a point in the neutral axis of the mid-section of the beam will be equal and opposite to the moment of the flexural forces. If P (Fig. 78) is an eccentric axial force, and y is the distance of its point of application above or

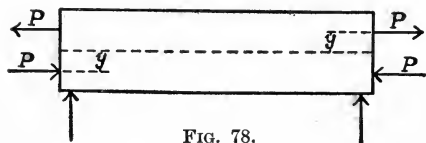

FIG. 78.

below the neutral plane, then before any bending takes

place Py is the moment of the axial force about a point in the center of the beam. Let M be the maximum moment of the flexural forces; then if the axial force is compression and the distance y measured below the neutral plane has such a value that $M = Py$, the resultant bending moment will be zero. Similarly, when the axial force is tension, if y is measured above the neutral surface and its value taken so that $Py = M$, the resultant bending moment will also be zero.

ART. 79. Shear and Axial Stress.

When a bar which is subjected to an axial stress is acted on by forces at right angles with the axis, there are tensile or compressive and shearing stresses at every point in that bar. Let Fig. 79 represent an elementary cube

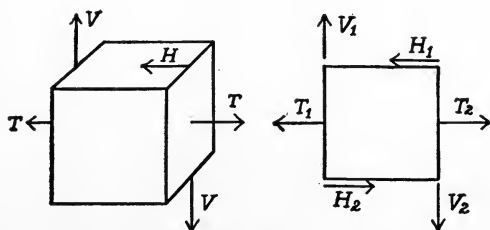

FIG. 79.

cut from any portion of the bar at which there are tensile or compressive stresses parallel, and shearing stresses perpendicular to the axis. The tensile or compressive forces T_1 and T_2 act on opposite sides of the cube, and the shearing forces V_1 and V_2 on parallel faces. Since they differ only by differential quantity, $T_1 = T_2$ and $V_1 = V_2$. The cube is not in equilibrium unless a pair of equal shearing forces H_1, H_2 are introduced. As the cube is in equilibrium and the arms of the couples are equal, it follows that $V = H$. Since the elementary block was a cube, the unit stresses

due to the equal forces H and V must be equal. Hence at every point of the bar there exists a pair of equal unit shearing stresses at right angles to each other, in addition to the unit tensile or compressive stresses. The tensile or compressive and shearing unit stresses that exist at every point in the bar combine and create shearing and tensile or compressive unit stresses that are greater than the original unit stresses.

ART. 80. Maximum Stresses.

To determine these maximum stresses let Fig. 80 represent an elementary parallelepiped cut from any portion of the bar.

Let its length be dx , height dy , width unity, and the faces be parallel and perpendicular to the axis of the bar.

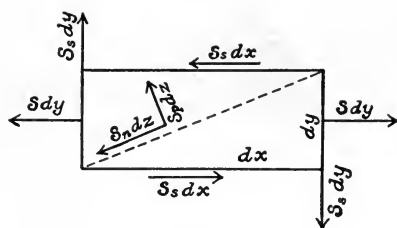

FIG. 80.

The area on which the tensile or compressive forces act is dy times unity, while that on which the shearing forces act, is either dy or dx times unity. The forces that act on opposite sides may be considered to be

equal since they differ by an infinitesimal quantity. Let S_s be the unit shearing stress and S the unit tensile or compressive stress. The force that acts perpendicular to the dy face is Sdy and the shearing force in the same plane is $S_s dy$. The shearing force in the dx face is $S_s dx$. Let dz be the diagonal, ϕ the angle between dx and dz , S_n the unit stress perpendicular to dz , and S_p the unit shearing stress along dz . Resolving the forces that act on

either side of dz into components parallel and perpendicular to dz we have

$$S_p dz = S dy \cos \phi + S_s dx \cos \phi - S_s dy \sin \phi, \quad (1)$$

$$S_n dz = S_s dx \sin \phi + S dy \sin \phi + S_s dy \cos \phi. \quad (2)$$

Divide each of these equations by dz , make $\frac{dy}{dz} = \sin \phi$ and $\frac{dx}{dz} = \cos \phi$, and equations (1) and (2) reduce to

$$S_p = S \sin \phi \cos \phi + S_s (\cos^2 \phi - \sin^2 \phi), \quad (3)$$

$$S_n = S \sin^2 \phi + 2 S_s \sin \phi \cos \phi. \quad (4)$$

Writing the equivalents of $\sin \phi$ and $\cos \phi$ in terms of 2ϕ , we have

$$S_p = \frac{S}{2} \sin 2\phi + S_s \cos 2\phi, \quad (5)$$

$$S_n = \frac{S}{2} (1 - \cos 2\phi) + S_s \sin 2\phi. \quad (6)$$

By the usual process

$$S_n \text{ is a maximum when } \tan 2\phi = -\frac{2 S_s}{S};$$

$$S_p \text{ is a maximum when } \tan 2\phi = \frac{S}{2 S_s}.$$

Substituting these values of ϕ in equations (5) and (6), we find that the maximum values of S_n and S_p are

$$S_n = \frac{1}{2} S \pm \sqrt{S_s^2 + \frac{1}{4} S^2},$$

$$S_p = \pm \sqrt{S_s^2 + \frac{1}{4} S^2}.$$

In these expressions S_n and S may be either tension or compression. When the positive sign is used before the radical, S_n is the same kind of stress as S . When the value of S_n is obtained by using the negative sign before the radical, S_n is compression when S is tension, and *vice versa*. When there is no shearing stress, $S_s = 0$ and the

value of S_n is S , while the value of S_p is $\frac{1}{2} S$. For $S_s = 0$ the $\tan 2\phi = \infty$ or $\phi = 45^\circ$. ϕ is the angle between the directions of the tensile or compressive unit stresses and the plane on which the maximum stress acts, hence the maximum S_p makes an angle of 45° or 135° with the direction of S . The angle that S_n makes with S under the same conditions is the $\tan^{-1} \phi = 0$. This latter expression shows that $S = \frac{P}{A}$ will give the maximum unit tensile or compressive stress in a bar on which there are axial forces only.

These formulas are general and apply to all combinations of tensile and compressive with shearing stresses without regard to the nature of the force producing the stresses.

When the unit stress S is induced by axial forces, the value of $S = \frac{P}{A}$. The stress S may also be due to a bending moment, and in that case the value of S is taken from $S = \frac{Mc}{I}$. S_s may be due to a simple shearing force or the result of a twisting moment.

In the former case the value of S_s to be used is derived from $S_s = \frac{P}{A}$, and in the latter case $S_s = \frac{Ppc}{J}$. When the bar under axial forces is a long column, Rankine's formula for long columns must be used to find the value of S . This formula may be written $S = \frac{P}{A} \left(1 + n\phi \frac{l^2}{r^2} \right)$, from which the value of S may be easily found.

ART. 81. Horizontal Shear in Beams.

There is a tensile or compressive unit stress in every fiber of a beam that is equal to $S = \frac{Mc}{I}$ and at the same

time a unit shearing stress resulting from the vertical shear. When the formula $V = AS_s$ was derived, it was assumed that the shearing stresses were uniformly distributed over the section of the beam. In the previous article it was

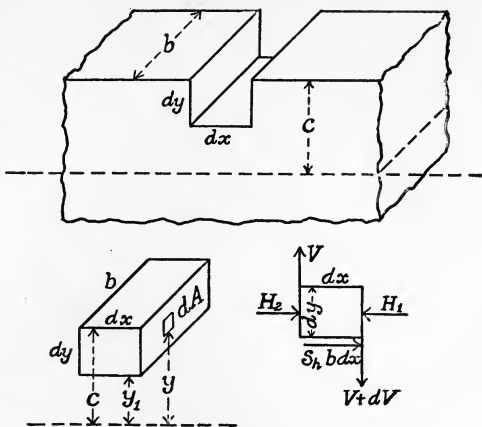

FIG. 81.

shown that there was a pair of shearing stresses at right angles to each other.

Therefore in any beam there is also a horizontal unit shearing that is equal to the vertical unit shearing stress at all points of the beam. To deduce an expression for the horizontal unit shearing stress at any point of a beam imagine a parallelepipedon cut from the top half of any beam (Fig. 81).

Let the length be dx , the width b , the distance of the lower side from the neutral axis y_1 , and the distance of the top of the beam from the same axis c . The faces are to be taken as parallel and perpendicular to the axis of the beam.

There are compressive forces acting on each end of the elementary block which vary in intensity directly as their distance from the neutral axis. Let S be the unit compressive stress at the upper surface, and dA a differential area at any distance y from the neutral axis; then $\frac{S}{c} y dA$

is the force acting at the distance y from the neutral axis. The sum of the horizontal forces acting on either end of the elementary block is the sum of the compressive stresses acting on the same area. Calling this sum $H = \frac{S}{c} \int_{y_1}^c y dA$, and writing $\frac{M}{I}$ for $\frac{S}{c}$, we have $H = \frac{M}{I} \int_{y_1}^c y dA$. Let the bending moments at the ends of the block be M_1 and M_2 , and the sum of the compressive stresses on the same ends be H_1 and H_2 . Since the ends are separated by dx , $M_1 - M_2 = dM$; then $H_1 - H_2 = \frac{dM}{I} \int_{y_1}^c y dA$. For equilibrium a force equal to $H_1 - H_2$ must be introduced, and this force must be equal to the sum of the shearing stresses on the area dx times b .

This sum is a horizontal shearing force, and the unit stress is $\frac{H_1 - H_2}{b dx}$. Therefore if S_h is the horizontal unit shearing stress, $S_h = \frac{dM}{dx} \frac{1}{Ib} \int_{y_1}^c y dA$. From the theory of beams $V dx = dM$ or $\frac{dM}{dx} = V$. Substituting V for $\frac{dM}{dx}$ in the expression for S_h , we have $S_h = \frac{V}{Ib} \int_{y_1}^c y dA$ as the value of the unit shearing stress at a distance y_1 from the neutral axis.

The parallelepipedon could have been cut from the lower half of the beam where the stress is tension and the reasoning would be equally true. The formula gives the value of the unit shearing stress at a distance y_1 from the axis, in a section for which V is the vertical shear as defined in the chapter on beams. The width of the beam at a distance y_1 from the axis is b , I is the moment of inertia of the entire section, while $\int_{y_1}^c y dA$ is the static moment

of the area of the section lying above the distance y_1 from the neutral axis. If c_1 is taken as the distance of the center of gravity of the area above y_1 from the neutral axis and a_1 is that area, then $\int_{y_1}^c y dA = a_1 c_1$, and $S_h = \frac{V}{Ib} a_1 c_1$.

For a point $y_1 = c$ from the axis, $a_1 c_1 = 0$, and therefore $S_h = 0$ at the distance c from the neutral axis. When a_1 is the whole area above the axis, S_h will be a maximum for that section. The greatest value of S_h for the beam will be found at the neutral surface in the section where the vertical shear is a maximum, since the value of S_h varies directly with V . Similarly, there will be no horizontal unit shearing stress in the sections where $V = 0$. It has been proven that for any point in a section of a beam there was a horizontal unit shearing stress that was equal to the vertical unit shearing stress at the same point. The expression just derived for S_h shows that the horizontal unit shearing stress is a variable quantity in any section of the beam, therefore the vertical unit shearing stress must also be variable. For a rectangular section, breadth b , depth d , the value of S_h for any section is $\frac{3}{2} \frac{V}{bd}$ instead of $S_s = \frac{V}{bd}$, showing the maximum horizontal shearing unit stress, and therefore the maximum vertical unit shearing stress is 50 per cent greater than the assumption of uniform distribution of stress would indicate. In determining the conditions for the safety of a beam, if the unit stress derived from the formula $S = \frac{Mc}{I}$ is a safe stress, the beam will in most cases be safely loaded. When a beam is short and deep, the horizontal unit shearing stress along the neutral surface may exceed the

safe unit shearing stress. This is especially true of timber beams on account of the low value of the ultimate shearing strength of timber along the grain. Hence the value of the shearing stresses should always be investigated, as no beam is known to be safely loaded until the unit stresses of all kinds have been determined and found safe.

ART. 82. Maximum Stresses in Beams.

In the general theory of beams as presented in Chapter III, the shearing stress due to the vertical shear was assumed to be uniformly distributed over the area of the section of the beam. That this assumption was not strictly true is evident from the equality of the variable value of the horizontal unit shearing stress with the unit vertical shearing stress in the same section. The value of S_h being a maximum or zero, as V is a maximum or zero, shows that S_h is zero when M is a maximum, or that there are no shearing stresses in the section for which M is a maximum. The value of S as derived from $S = \frac{Mc}{I}$ will, therefore, be the true unit stress for any section where M is a maximum bending moment for the beam. The shearing stresses in the fibers along the upper and lower sides of the beam are also zero, since $a_1c_1 = 0$. Hence the unit stresses in these fibers at the various sections of the beam will be the value of S as derived from $\frac{Mc}{I}$, when M is the bending moment for the section considered.

The unit tensile or compressive stress being zero along the neutral surface, the unit stress along that axis is one

of shear, and its value may be found from the expression for S_h . For simple beams M is zero at the supports and the unit stress at all points of the section is simply S_h .

With these exceptions the unit stress at all points in a beam is a combination of the tensile or compressive stresses with the shearing stresses. The value of the maximum unit stress at any point in the beam may be found from the expressions for the maximum values of S_n or S_p , when S_h is substituted for S_s . These maximum stresses make angles with the axis of the beam that depend for their value on the relative values of S and S_h .

The unit stress given by $\frac{Mc}{I}$ is the true unit stress, when

M is a maximum moment, and it is easy to see by an inspection of the expressions for the maximum values of S_n and S_p that their values can rarely ever exceed those

given by $\frac{Mc}{I}$ and $\frac{V}{Ib} \int_{y_1}^c y dA$. When a beam is deep

vertically and carries a concentrated load at the center, the value of V is constant for all sections up to the middle of the beam. Therefore it is possible in such a beam that the maximum value of S_n may exceed the

maximum value of S as found from $\frac{Mc}{I}$. This is espe-

cially true of beams having I sections, as the value of the static moment of the flanges is nearly as large as the moment of the whole area above the neutral axis. The value of S_h in the web just below the flange being very large, for a section just to the left of the load where V is a maximum and S nearly so, the values of S_n and S_p may be greater than the maximum values of S and S_h .

The shearing stress S_p at any point of the beam is a stress that is inclined at angles that vary from 0° to 45° with the axis of the beam. When the beam has an I section and is deep, these shearing stresses have a tendency to cause the web to buckle. To resist this tendency vertical angle irons are often riveted to the webs. When a beam of an I section is composed of angle irons riveted to a web plate, making what is known as a plate girder, the force on the rivets joining the angles to the web can be found from the values of S_n and S_h , and the areas over which these stresses are distributed.

While the theory of beams as presented in Chapter III was defective in its assumptions regarding the distribution of the shearing stress, and its neglect of the combined stress, this discussion shows that for the majority of beams the formula $S = \frac{Mc}{I}$ will give the maximum bending stress when the value of M is a maximum. The formula may be used for the design of all beams and the dimensions checked for safety by determining the values of S_n , S_p , and S_h .

EXAMINATION

Give some examples of bars where the forces acting produce more than one kind of stress.

When a bar under bending forces also has a tensile or compressive axial force acting on it, why does not the resulting unit stress always equal the sum of the unit stresses due to each force?

Develop the expression

$$S_1 = \frac{Mc}{I \pm \frac{\alpha l^2 P}{\beta E}}$$

where S_1 is the maximum unit stress due to both the axial and bending forces acting on any bar.

What assumptions are made in the development of the formula that are not strictly true?

When a beam which carries bending loads also has to resist tensile or compressive loads, how can the resulting bending moment be made practically zero?

When a bar is subjected to both axial and shearing forces, show that at every point of the bar there is a pair of equal unit shearing stresses whose directions make right angles with each other.

What is the effect of the combination of shearing with unit tensile stresses? Is the effect any different if the shearing stress is combined with an equal stress in compression?

Show how to determine the value of the maximum unit stress when tensile or compressive stresses are combined with shearing stress?

A bar is being acted on by tensile or compressive forces applied in the line of the axis. Is there any shearing stress? How may its value be determined?

If the maximum tensile or compressive unit stress is given by

$$S_n = \frac{S}{2} \pm \sqrt{S_s^2 + \frac{1}{4}S^2},$$

and the positive sign is used before the radical, what kind of stress is S_n ?

What is meant by the expression "horizontal shear" in beams?

Deduce an expression for the horizontal unit shearing stress at any point of a beam.

Under what conditions will the unit stress given by

$S = \frac{Mc}{I}$ be the maximum unit tensile or compressive stress in a beam?

Under what conditions may the horizontal shearing stress become the most dangerous stress in the beam?

A deep I beam is short and carries a load at the middle. Is it possible that at some point in the beam there may be a unit tensile or compressive stress greater than that given by $S = \frac{Mc}{I}$ when the value of M is that of the maximum bending moment for the beam?

When a beam is rectangular in section, where will the maximum unit shearing stress be found? Is the same true for beams of other sections?

PROBLEMS

1. A roof with two equal rafters has a span of 40 ft. and a rise of 15 ft. If the weight of the rafter is neglected, determine the size of the rafters 6 in. wide when each rafter carries a uniform load of 50 lb. per foot.

Assume the allowable unit stress as 600 lb. / sq. in.

2. Assume the rafters in problem 1 to carry a load of 1000 lb. at the middle, instead of the uniform load, and find the depth of the rafters for the same unit stress.

3. A simple wooden beam, 30 ft. long, 12 in. deep, and 4 in. wide, carries a single load of 320 lb. at the middle and an axial compressive load of 14,400 lb. Find the maximum unit stress in the beam,

(a) by the approximate method,

(b) by the more exact method.

4. A simple steel I beam 20 ft. long, 12 in. deep, weighing 35 lb. / ft., carries a uniformly distributed load

of 500 lb./ft. and sustains a compressive load of 40,000 lb. Is it safe if a factor of safety of 5 is needed?

5. Find the points of application of the compressive loads in problem 4 so that the unit stress resulting from the effect of the loads will be as small as possible.

6. A steel eye bar 30 ft. long has a section area of 2 by 6 in. The eye bar is to be used horizontally, and carries a tensile load of 288,000 lb. Determine the distance from the center of the eyes to the axis of the bar so that the resulting unit stress will be as small as possible.

7. Determine the value and location of the maximum unit shearing stress in the beam as given in problem 3.

8. If the point of application of the compressive forces in problem 3 is taken so as to neutralize the effect of the central load, determine the value of the maximum shearing unit stress.

9. A simple steel I beam, 20 ft. long, 12 in. deep, weighing 35 lb./ft., carries a concentrated load of 30,000 lb. at the middle. Determine the maximum horizontal unit shearing stress. What is the value of the total maximum shearing force?

10. Given the same beam as in problem 9, carrying the same loads, find the difference between the maximum unit tensile stress and the stress given by the formula

$$S = \frac{Mc}{I}.$$

11. A horizontal steel shaft, 5 in. in diameter, is 20 ft. between bearings, and carries a load of 1200 lb. at the center. It transmits 250 H.P. at 100 revs./min. Required the maximum unit stress induced.

12. A standard 2-in. steel bolt is screwed so as to cause a unit tensile stress of 10,000 lb./sq. in. What

shearing force may be resisted if the maximum unit stress is not to exceed 15,000 lb./sq. in.?

13. How many 1-in. standard steel bolts must be used to resist a shearing force of 300,000 lb. if the tensile stress due to screwing up is assumed to be 10,000 lb./sq. in. and the allowable maximum unit stress is taken as 12,000 lb./sq. in.?

14. An angle iron is bolted to the side of an I beam and supports another beam whose reaction at the supported end is 50,000 lb. Select a number of 1-in. bolts to carry the load. Assume that the unit stress in each bolt due to screwing up is 12,000 lb./sq. in., and the factor of safety is 4.

CHAPTER VIII

COMPOUND BARS AND BEAMS

ART. 83. Definition.

When a bar is composed of more than one kind of material it is sometimes termed a compound bar. The formulas derived in the previous chapters apply only to bars made of one material throughout. This chapter will be devoted to the investigation of a few of the simpler cases of stress in the compound bars.

ART. 84. Compound Columns; alternate layers.

A column or pier built with alternate layers of different materials, as in Fig. 84, will evidently carry only the load the weaker section will support. The unit stress in any section may be found when the area of the section is known, as each section has to support the entire load.

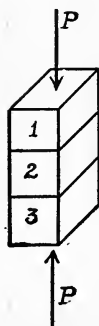

FIG. 84.

When the modulus of elasticity of the material and the length of each section are known, then the amount of shortening for each section can be found as for simple bars. The total shortening of the entire column is the summation of the deformations of the different sections.

ART. 85. Compound Columns; longitudinal layers.

When a column is composed of different materials arranged longitudinally, the column becomes a bundle

of simple bars. Each bar does not carry a part of the total load that is proportional to its area as in the previous case. All the bars have the same amount of deformation, and when the unit stress is within the elastic limit, the unit stress in each bar must vary directly as the modulus of elasticity.

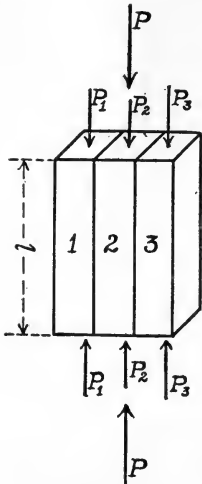

FIG. 85.

In Fig. 85 let E_1 , E_2 , E_3 , be the moduli of elasticity of the three bars, and the areas be A_1 , A_2 , A_3 , and the common deformation and length, e and l ; then,

$$E_1 = \frac{S_1 l}{e}, \quad E_2 = \frac{S_2 l}{e}, \quad E_3 = \frac{S_3 l}{e}.$$

Writing for S_1 , S_2 , and S_3 , their values in terms of the loads and areas, we have

$$e = \frac{P_1 l}{A_1 E_1} = \frac{P_2 l}{A_2 E_2} = \frac{P_3 l}{A_3 E_3}. \quad (1)$$

As the sum of the partial loads must be equal to the total load,

$$P = P_1 + P_2 + P_3. \quad (2)$$

Equations (1) and (2) will suffice to fully determine the values of the partial loads P_1 , P_2 , and P_3 , when the length, moduli of elasticity, and areas are known.

The above discussion will apply equally well to compound bars under tensile forces, as the stress in each case is the result of an axial force.

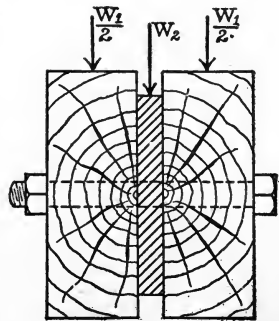

FIG. 86 a.

ART. 86. Compound Beams.

When a beam is composed of two different materials, the load carried by the beam is divided between the two beams of the different materials in a similar manner as in the case of a compound bar under compressive forces (Fig. 86). The deflection for each part of the beam is the same, and if the deflection is expressed as

$$f = \frac{Wl^3}{\beta EI}, \text{ then in the given case}$$

$$f = \frac{W_1 l^3}{\beta E_1 I_1} = \frac{W_2 l^3}{\beta E_2 I_2}, \text{ and } W = W_1 + W_2.$$

In the above expressions W is the total load carried by the beam and W_1 and W_2 are the partial loads carried by each material of the beam.

The equations will suffice to determine the safety of a compound beam under any loading.

To design a beam to be composed of wood and steel, the size and shape of either material may be assumed and the load it will carry with a

safe unit stress calculated. Either W_1 or W_2 being found, the other becomes known at once.

The shape of the required part of the beam may be found from the equations resulting from the equality of the deflections. The solution is a tentative one, as the unit stresses must all be within the elastic limit for the equations to hold true.

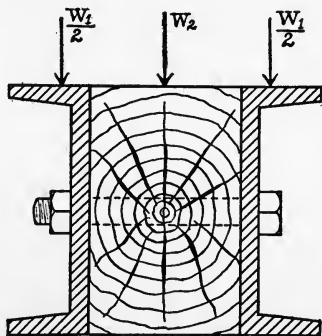

FIG. 86 b.

ART. 87. Reënforced Concrete Beams.

Concrete, being a material strong in compression and rather weak in tension, is not suitable as a material for use in beams. To remedy the defect in tensile strength, steel rods are embedded in the concrete below the neutral axis. The steel supplies the tensile strength that is lacking in the concrete, and as the concrete is fireproof and non-corrosive, the combination of concrete and steel, known as reënforced concrete, is used extensively in all building operations. Steel I beams are often imbedded in concrete, but this is done mainly to protect the beam from corrosion.

The common theory for the design of reënforced concrete beams neglects the tensile strength of the concrete and considers the entire tensile load to be carried on the steel reënforcement.

Experiments made on concrete in compression do not agree as to the possible variation of the modulus of elasticity with the unit stress. The theory given here assumes that the value of the modulus of elasticity is constant for all stresses that are allowable in engineering structures. The so-called parabolic formulas are derived on the assumption that the value of E decreases with an increase of stress. With a fair value of the ratio of the areas of steel to concrete the two formulas give nearly the same results.

ART. 88. Straight Line Formula.

In the derivation of the straight line formula for the strength of reënforced beams the following assumptions are made:

1. That the unit compressive stress in the concrete varies directly as the distance from the neutral axis.

2. That the unit tensile stress in the steel reinforcement is constant and depends on the distance of its center of gravity from the neutral axis.

3. That the entire tensile stress is carried by the steel reinforcement, the tensile strength of the concrete being neglected.

4. That the neutral axis is located so that the tensile resistance of the steel is equal to the total compressive resistance of the concrete.

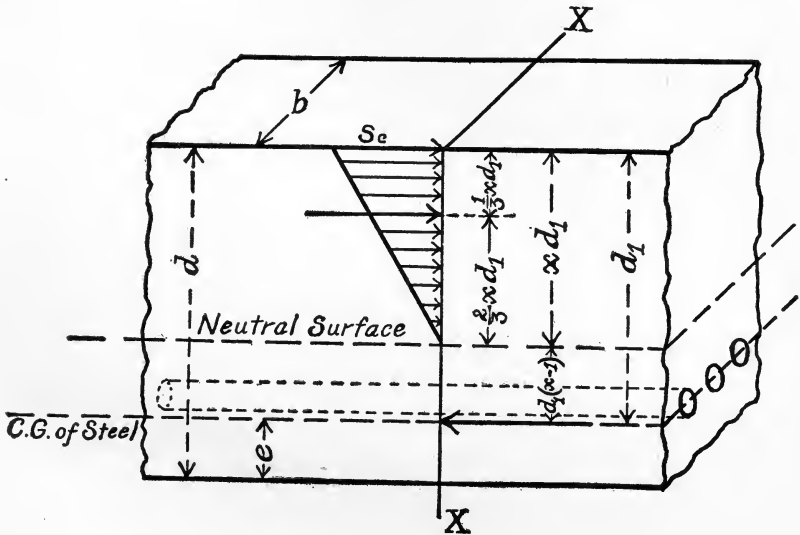

FIG. 88.

5. Perfect adhesion between the steel and concrete.

6. That the value of the modulus of elasticity of the concrete is constant.

Let Fig. 88 represent a portion of a reinforced concrete beam, and $X-X$ the location of the dangerous section.

NOTATION

- d = the depth of the beam.
 b = the breadth of the beam.
 z = the ratio of the sectional area of the steel reënforcement to the sectional area of the concrete above the center of gravity of the steel.
 S_c = the maximum unit compressive stress in the concrete.
 S_t = the maximum unit tensile stress in the steel.
 E_c = the modulus of elasticity of the concrete.
 E_s = the modulus of elasticity of the steel.
 y = the ratio $\frac{E_s}{E_c}$.
 d_1 = the distance of the outer compression fiber in the concrete to the center of gravity of the steel.
 x = the ratio of the depth of the neutral axis to the depth of the center of gravity of the steel, both being measured from the outer fiber of the concrete in compression.
 xd_1 = the distance of the neutral axis from the outer fiber of the concrete in compression.
 M_r = the maximum moment of resistance.
 M = the maximum bending moment for the beam.
 e = the depth of concrete below the center of gravity of the steel.
 l = the length of the beam.
 Linear unit, the inch; unit of weight, the pound.

For equilibrium, the resultant of the compressive stresses in the concrete must be equal to the tensile stress in the steel, and the moment of the couple formed by these two forces must be equal to the bending moment for the beam.

Since all the stresses are within the elastic limit, the deformation of the fibers of the concrete and steel are proportional to their distance from the neutral axis; hence

$$\frac{\frac{S_t}{E_s}}{\frac{S_c}{E_c}} = \frac{d_1(1-x)}{xd_1} \tag{1}$$

Solving for S_c and writing y for the ratio of E_s to E_c , we have

$$S_c = S_t \frac{x}{y(1-x)} \tag{2}$$

Solving (2) for x , we have

$$x = \frac{1}{1 + \frac{S_t}{S_c y}} \tag{3}$$

The area over which the compressive forces is distributed being xd_1b while that for the steel is zd_1b , and since the total forces are equal,

$$zd_1bS_t = \frac{xd_1b}{2} S_c, \text{ or } zS_t = \frac{xS_c}{2} \tag{4}$$

Substituting for x its value taken from (3) and solving for z , we have

$$z = \frac{1}{2 \left(\frac{S_t}{S_c} \right) \left(1 + \frac{S_t}{S_c y} \right)} \tag{5}$$

Equation (5) gives the required value to the ratio z in order that the given values of S_c and S_t may be developed. (It must be noticed that z depends for its value on the relative values of S_c , S_t , E_c , and E_s , and can not be assumed at will, if the full strength of the steel and concrete is to be made available.)

Eliminating S_c from (2) and (4), we have

$$z = \frac{x}{2} \left(\frac{x}{(1-x)y} \right) = \frac{x^2}{2(1-x)y}, \quad (6)$$

and solving for x ,

$$x = yz \left(\sqrt{1 + \frac{2}{yz}} - 1 \right). \quad (7)$$

Equation (7) gives the ratio x in terms of y and z ; hence the location of the neutral axis may be found when these ratios are known.

The value of the resisting moment can be found by taking the moment of the tensile force in the steel reinforcement about a point in the line of action of the resultant of the compressive forces in the concrete; therefore,

$$M_r = S_t z d_1 b \left(d_1 - \frac{x d_1}{3} \right) = S_t z b d_1^2 \left(1 - \frac{x}{3} \right). \quad (8)$$

The value of M_r may be found in terms of S_c in a similar manner to be

$$M_r = S_c \frac{x b d_1^2}{2} \left(1 - \frac{x}{3} \right). \quad (9)$$

Equating the maximum bending moment for a given beam to the value of M_r as given by either equations (8) or (9) will give a relation between the bending moment and the dimensions of the beam. The resulting equations may be used to investigate the safety of a given beam or to design a beam to carry a given load.

When the ratio z is given, equation (5) shows that the ratio of $\frac{S_t}{S_c}$ must have a definite value.

If the given value of z is larger than necessary, the full strength of the steel will not be utilized. The allowable value of S_c becomes the limiting factor, and its

value may be assumed. This assumed value used in equation (5) will determine the value of the unit stress in the steel.

On the other hand, when the value given for z is too small, the safe unit stress in the steel becomes the limiting condition and the full safe strength of the concrete can not be made available. In any case neither S_c or S_s can exceed the elastic limit of the material and should not exceed a safe working stress.

The depth, e , of the concrete below the center of gravity of the steel does not enter into the formula, as the tensile strength of the concrete is neglected. Evidently, to get the most value for the steel reënforcement it should be placed as close to the lower side of the beam as possible. The assumption that the bond between the steel and the concrete is perfect requires that there shall be a reasonable thickness of concrete around the steel. Therefore the depth e must be determined by practice. The depth should never be less than one inch.

The extensive use of reënforced concrete is of comparatively recent date, and while there has been a great deal of experimental work done on reënforced concrete beams and columns, much more will have to be done before the theory for their design can be considered as good as that for beams of one material. There are so many variable conditions to be taken into account that various experimenters have arrived at seemingly contradictory results.

The formula as given here is the one in general use and appears to give reliable results. The allowable unit stresses are generally taken lower than the usual practice for the same materials under conditions where the effect of the load is better understood.

The form of the steel reënforcement is a subject to which experimenters have given a great deal of attention, the object being to find the form that will insure the best bond between the steel and the concrete.

The value of the modulus of elasticity for concrete depends on the proportions of cement, sand, and broken stone in the concrete. The value of E ranges from 4,000,000 to as low as 850,000, the lower value being for a cinder concrete and the upper value for a $1:1\frac{1}{2}:3$ mixture. A fair average value for E may be assumed to be 3,000,000. Taking the modulus of elasticity of steel as 30,000,000, the ratio of $\frac{E_s}{E_c} = 10$. The allowable unit stress in steel may be taken as varying from 10,000 to 12,000 lb./sq. in. for steady loads and the corresponding value of the safe unit stress in the concrete ranges from 500 to 600 lb./sq. in. The ratio of $\frac{S_t}{S_c}$ then becomes about 20.

These values inserted in equation (5) give a value of z as slightly over .8 per cent. The usual values of z range from .75 per cent to 1.50 per cent.

To determine the safety of a reënforced concrete beam carrying a given load, first find the limiting value of the unit stress in the steel or concrete. This being done, the equation resulting from placing the maximum bending moment of the beam equal to the right hand member of either equation (8) or (9), as the unit stress in the steel or concrete is the limiting stress, will suffice to determine the value of that stress.

To design a reënforced beam, z may be assumed and limiting stress found, or z may be calculated by the use

of either equations (4) or (5), using the maximum allowable values for S_t and S_c . Either b or d_1 may be assumed, and equating the maximum bending moment for the beam to the expression for the resisting moment will suffice to determine the other dimension. The total depth d is equal to $d_1 + e$, where e must be assumed empirically.

If z is assumed, the equation for the resisting moment that depends for its value on the limiting stress must be used.

EXAMINATION

What is a compound bar?

When a compound bar is used as a short column, will the formula for axial compression always give the true maximum unit stress? Explain your answer fully, giving reasons.

When a beam is composed of more than one kind of material, name the conditions that are used to determine the part of the load carried by each material.

What is meant by "reënforced concrete"?

In the development of the "straight line" formula for the strength of a reënforced concrete beam, certain assumptions are made. What are they?

Can the tensile stress in the steel, the maximum compressive stress in the concrete, and the ratio of the section area of the steel to that of the concrete be assumed at will?

How many of the three can be assumed?

Equation (8) of Art. 88 is an expression for the resisting moment for a reënforced concrete beam. Explain why it is true.

If the ratio z is too large, what can you say of the unit stress in the steel?

If z is too small, can the full strength of the concrete be made available? Explain fully.

PROBLEMS

1. A wooden column, section area 36 sq. in., is used to support a floor. The load on the floor is to be increased and a hollow circular cast iron column 6 in. external and 4 in. internal diameter is placed beside the wooden column. What part of the total load will each carry?

2. A load of 60,000 lb. is to be carried on a hollow cast iron column 6 in. internal diameter. The interior of the column is filled with concrete; how thick should the cast iron be if the maximum unit stresses in the cast iron and concrete are 3000 and 750 lb./sq. in., respectively?

3. If the column in problem 2 was filled with wood instead of concrete, how thick should the cast iron be made?

4. A standard 6-in. steel pipe is encased in concrete 2 in. thick and used as a column. How much more load may be carried with, than without, the concrete?

5. Two standard 12-in. steel channels weighing 25 lb./ft. are to be bolted to the sides of a wooden beam 4 in. wide, 12 in. deep, and 20 ft. long. What uniform load including the weight of the beam may be carried? Maximum unit stress in the steel 12,000 lb./sq. in., and 600 lb./sq. in. in the wood.

In the following problems the maximum allowable unit stress in the concrete may be taken as 600 lb./sq. in. and steel as 12,000 lb./sq. in., and the value of y as 10.

6. A reënforced concrete beam 6 in. deep, 4 ft. wide, and 6 ft. span has 2 sq. in. of steel reënforcement placed 2 in. from the lower side. What uniform load including

its own weight will it carry? What are the maximum unit stresses in the steel and the concrete?

7. Find the proper area for the steel in a beam similar to the one given in problem **6**.

8. A concrete beam 10 ft. long and 6 in. square is to be reënforced by steel rods placed 2 in. from the lower side. Find the proper area for the steel reënforcement.

9. What uniform load will the beam in problem **8** carry with safety?

10. What load could be carried without any reënforcement, assuming the tensile stress in the concrete to be 150 lb./sq. in.?

TABLES.—EXPLANATION OF

TABLE I. NOTATION.

The number following the description of each symbol refers to the article where the symbol was introduced.

TABLE II. FUNDAMENTAL FORMULAS.

TABLE III. DERIVED FORMULAS.

The numbers following each expression refer to the chapter and article in which the formula was derived.

TABLE IV. PROPERTIES OF BEAMS.

The columns 1 and 2 give the relative strengths and stiffness of the various kinds of beams of the same length and shape. Columns 3 to 6 are the expressions for Maximum Vertical Shear, Bending Moment, Unit Stress, and deflection of the various beams under uniform and single concentrated loads. Columns 7 and 8 give the values of α and β for the various beams; for a description of these symbols see: for α , Art. 48; β , Art. 64.

TABLE V. CONSTANTS OF MATERIALS.

This table has been compiled solely for the use of the student in solving the problems in the text. As all the constants are liable to considerable variation, it should not be used in the design of a structure that is to be built.

TABLE VI. PROPERTIES OF SECTIONS.

In the rectangular sections d is the dimension in the direction of bending. In the hollow sections d_1 and b_1 are the inside dimensions.

TABLES VII AND VIII. PROPERTIES OF I AND CHANNEL BEAMS.—
CAMBRIA STEEL.

These tables have been inserted for the convenience of the student. As every engineer should own some of the trade books giving the properties of the various steel shapes, he will prefer to get his data first hand.

NOTATION.—TABLE I

A	area of cross section.	4.
a	a distance.	72.
b	breadth of a beam.	41.
C, C_1, C_2 , etc.	constants of integration.	64.

c	distance from neutral axis to most distant fiber. 40.
D	internal diameter of a pipe. 24.
D	mean diameter of coils (helical springs only). 61.
D_1	external diameter of thick pipe. 25.
d	diameter of rivets. 27.
d	diameter of bolts in shaft couplings. 59.
d	diameter of wire for helical springs. 61.
d	depth of a beam. 41.
d_1	a distance (reënforced concrete only). 88.
E	modulus of elasticity. 12.
E_b, E_c	modulus of elasticity for concrete and steel (reënforced concrete only). 88.
e	total deformation in length of bar. 11.
e	a distance (reënforced concrete only). 88.
F	factor of safety. 21.
F	shearing modulus of elasticity. 56.
f	maximum deflection for a beam. 73.
h	distance between parallel axes. 74.
I	rectangular moment of inertia. 40.
J	polar moment of inertia. 52.
J'	polar moment of inertia of bolts about shaft axis (shaft couplings only). 59.
K	total elastic resistance of a bar. 18.
k	elastic resistance of a material. 17.
l	a length. 11.
M	the bending moment. 40.
M_1, M_2	bending moments due to resultant couples. 64.
M_r	moment of resistance (reënforced concrete only). 88.
N	number of revolutions per minute. 58.
N_1, N_2, N_3	bending moments at the supports in continuous beams. 67.
n	number of concentrated loads on a beam. 64.
n	constant depending on kind of column. 73.
n	number of bolts in a shaft coupling. 59.
P	external force. 4.
p	pitch of rivets. 30.
p	a distance. 43.
p	arm of twisting moment. 52.
R	pressure per square unit. 24.
r	radius of curvature. 63.
r	radius of gyration. 73.

R_1, R_2, R_3	reactions at the supports of a beam. 36.
S	unit stress, with subscripts $t, c,$ and s for unit stress in tension, compression, and shear. 9.
S_h	horizontal unit shearing stress in beams. 81.
S_p, S_n	maximum shearing and tensile unit stresses due to combined stresses. 80.
t	thickness. 24.
W	weight of a box or beam. 23.
W	total uniform load on beam, may include weight of beam. 36.
w	weight of a cubic unit of material. 23.
w	width of plate. 27.
w	uniform load on beam per linear unit. 36.
x, y	variable distances.
x, y, z	ratios (for concrete beams only). 88.
α, β	material constants. 46, 64.
ϕ	constant depending on material. 73.
θ	angle of twist. 52.

FUNDAMENTAL FORMULAS.—TABLE II

TENSION, COMPRESSION, AND SHEAR

$$(a) \quad P = AS. \quad \text{Chap. I, Art. 4.}$$

Applies to all cases of uniformly distributed stress.

MODULUS OF ELASTICITY FOR TENSION AND COMPRESSION

$$(b) \quad E = \frac{S}{\epsilon} = \frac{Pl}{Ae}. \quad \text{Chap. I, Art. 11.}$$

Applies to all problems where the unit stress in tension or compression is within the elastic limit.

BEAMS.—VERTICAL SHEAR

$$(c) \quad V = AS. \quad \text{Chap. III, Art. 39.}$$

True for all values of S .

BENDING MOMENT

$$(d) \quad M = \frac{SI}{c}. \quad \text{Chap. III, Art. 40.}$$

Applies to all problems where the value of S is within the elastic limit.

TWISTING MOMENT IN SHAFTS

$$(e) \quad P_p = \frac{SJ}{c} \quad \text{Chap. IV, Art. 53.}$$

$$(f) \quad F = \frac{Sl}{\theta c} = \frac{Ppl}{\theta J} \quad \text{Chap. IV, Art. 56.}$$

Applies to all problems where the value of S is within the elastic limit.

EQUATION OF ELASTIC CURVE

$$EI \frac{d^2y}{dx^2} = M. \quad \text{Chap. V, Art. 63.}$$

DERIVED FORMULAS.—TABLE III

STRENGTH OF BARS OF UNIFORM STRENGTH

$$\log_{10} A = 0.434 \frac{S}{w} y + \log_{10} A_0. \quad \text{Chap. II, Art. 23.}$$

THICKNESS OF STEAM AND WATER PIPES, CYLINDERS, ETC.

Thin pipes:

Longitudinal ruptures.

$$RD = 2 St. \quad \text{Chap. II, Art. 24.}$$

Circumferential ruptures.

$$RD = 4 St. \quad \text{Chap. II, Art. 24.}$$

Thick pipes:

Longitudinal ruptures.

$$RD_1 = 2 St. \quad \text{Chap. II, Art. 25.}$$

STRENGTH OF RIVETED JOINTS

$$\text{Tension in plate.} \quad t(p-d)S_t = P_t. \quad \text{Chap. II, Art. 30.}$$

$$\text{Shear on rivet.} \quad \frac{c\pi d^2}{4} S_s = P_s. \quad \text{Chap. II, Art. 30.}$$

$$\text{Compression on rivet or plate.} \quad c_1 t d S_c = P_c. \quad \text{Chap. II, Art. 30.}$$

HORSE POWER OF SHAFTS

$$H = \frac{PpN}{63,000} \text{ (approx.)} = \frac{S_s J N}{63,000 c}. \quad \text{Chap. IV, Art. 58.}$$

SHAFT COUPLINGS

Diameter of bolts. $Pp = n \frac{\pi d^2}{4} S_s'' h$ (approx.). Chap. IV, Art. 59.

HELICAL SPRINGS

Strength. $P = \frac{\pi d^3}{8 D} S_s.$

Deflection. $\delta = \frac{8 PD^3}{Fd^4} = \frac{S_s \pi D^2}{Fd}$. Chap. IV, Art. 61.

CONTINUOUS BEAMS. — THREE-MOMENT EQUATION

$N_1 l_1 + 2 N_2 (l_1 + l_2) + N_3 l_2 = - \frac{w_1 l_1^3 + w_2 l_2^3}{4}$. Chap. V, Art. 67.

LONG COLUMNS

Round ends.

Euler. $P = \frac{EI\pi^2}{l^2}$. Chap. VI, Art. 70.

Rankine. $P = \frac{AS_c}{1 + \phi 4 \frac{l^2}{r^2}}$. Chap. VI, Art. 73.

Square ends.

Euler. $P = 4 \frac{EI\pi^2}{l^2}$. Chap. VI, Art. 71.

Rankine. $P = \frac{AS_c}{1 + \phi \frac{l^2}{r^2}}$. Chap. VI, Art. 73.

Round and square ends.

Euler. $P = \frac{9}{4} \frac{EI\pi^2}{l^2}$. Chap. VI, Art. 72.

Rankine. $P = \frac{AS_c}{1 + \phi \frac{16}{9} \frac{l^2}{r^2}}$. Chap. VI, Art. 73.

COMBINED STRESSES

Tension or compression with bending.

$S = \frac{P}{A} + \frac{Mc}{I \pm \frac{\alpha}{\beta} \frac{Pl^2}{E}}$, Chap. VII, Art. 76.

or

$S = \frac{P}{A} + \frac{Mc}{I}$ (approx.).

Maximum tension, compression, or shear.

Tension or compression combined with shear.

Max. shear. $S_p = \pm \sqrt{S_s^2 + \frac{1}{4}S^2}$. Chap. VII, Art. 80.

Max. tension or
compression. $S_n = \frac{1}{2}S \pm \sqrt{S_s^2 + \frac{1}{4}S^2}$. Chap. VII, Art. 80.

HORIZONTAL SHEARING STRESSES IN BEAMS

$$S_h = \frac{dM}{dxIb} \int_{v_1}^c y dA. \quad \text{Chap. VII, Art. 81.}$$

REINFORCED CONCRETE BEAMS

and
$$\left. \begin{aligned} M &= S_c z b d_1^2 \left(1 - \frac{x}{3}\right), \\ M &= S_c \frac{x b d_1^2}{2} \left(1 - \frac{x}{3}\right). \end{aligned} \right\} \text{Chap. VII, Art. 88.}$$

PROPERTIES OF BEAMS. — TABLE IV

KIND OF BEAM AND LOADING	1 RELATIVE STRENGTH	2 RELATIVE STIFFNESS	3 MAX. VERTICAL SHEAR	4 MAX. BENDING MOMENT	5 MAX. TENSILE OR COMPRESSIVE UNIT STRESS	6 MAX. DEFLECTION	7 α	8 β
Cantilever loaded at end with W	1	1	W	Wl	$\frac{Wl}{I}$	$\frac{Wl^3}{3EI}$	1	3
Cantilever loaded uniformly with W	2	$\frac{8}{3}$	W	$\frac{Wl}{2}$	$\frac{Wl}{2I}$	$\frac{Wl^3}{8EI}$	2	8
Simple beam loaded at middle with W	4	16	$\frac{W}{2}$	$\frac{Wl}{4}$	$\frac{Wl}{4I}$	$\frac{Wl^3}{48EI}$	4	48
Simple beam loaded uniformly with W	8	$\frac{128}{5}$	$\frac{W}{2}$	$\frac{Wl}{8}$	$\frac{Wl}{8I}$	$\frac{5Wl^3}{384EI}$	8	$\frac{384}{5}$
Beam fixed at one end, supported at other, uniform load	8	62	$\frac{5W}{8}$	$\frac{Wl}{8}$	$\frac{Wl}{8I}$	$\frac{Wl^3}{186EI}$	8	186
Beam fixed at both ends, loaded at middle	8	64	$\frac{W}{2}$	$\frac{Wl}{8}$	$\frac{Wl}{8I}$	$\frac{Wl^3}{192EI}$	8	192
Beam fixed at both ends, loaded uniformly	12	128	$\frac{W}{2}$	$\frac{Wl}{12}$	$\frac{Wl}{15I}$	$\frac{Wl^3}{384EI}$	12	384

AVERAGE CONSTANTS OF MATERIALS. — TABLE V

MATERIAL	Elastic Limit $\frac{FL}{L}$ Lbs./Sq. In.	ULTIMATE STRENGTH			Modulus of Elasticity E Lbs./Sq. In.	Shearing Modulus of Elasticity K Lbs./Sq. In.	FACTORS OF SAFETY		
		Tension Lbs./Sq. In.	Comp. Lbs./Sq. In.	Shear Lbs./Sq. In. <small>Along Grain</small>			Steady Loads	Variable Loads	Shocks
Timber	3000	8000	8000	1200	1,500,000	140,000	8	10	15
Cast iron	3000	20,000	80,000	20,000	12,000,000	5,000,000	8	12	20
Wrought iron	25,000	55,000	55,000	45,000	28,000,000	10,000,000	4	6	10
Structural steel	30,000	60,000	60,000	50,000	30,000,000	12,000,000	4	6	10
Hard steel	80,000	100,000	100,000	90,000	30,000,000	15,000,000	5	9	15
Brick	—	500	3000	1000	—	—	15	25	40
Stone	—	—	6000	1500	—	—	15	25	40
Concrete	—	—	3000	—	3,000,000	—	15	25	40

PROPERTIES OF SECTIONS. — TABLE VI

SHAPE OF SECTION	AREA	MOMENT OF INERTIA GRAVITY AXIS		RADIUS OF GRAVITY SQUARES	SECTION MODULUS	
		I	J		$\frac{I}{c}$	$\frac{J}{c}$
Solid rectangle, breadth b , depth d	bd	$\frac{bd^3}{12}$	$\frac{bd^3 + b^3d}{12}$	$\frac{d^2}{12}$	$\frac{bd^2}{6}$	$\frac{bd^3 + b^3d}{6\sqrt{b^2 + d^2}}$
Solid square	d^2	$\frac{d^4}{12}$	$\frac{d^4}{6}$	$\frac{d^2}{12}$	$\frac{d^3}{6}$	$\frac{d^3}{4.24}$
Hollow rectangle	$bd - b_1d_1$	$\frac{bd^3 - b_1d_1^3}{12}$	—	$\frac{bd^3 - b_1d_1^3}{12(bd - b_1d_1)}$	—	—
Solid circle	$\frac{\pi d^2}{4}$	$\frac{\pi d^4}{64}$	$\frac{\pi d^4}{32}$	$\frac{d^2}{16}$	$\frac{d^3}{10.2}$	$\frac{d^3}{5.1}$
Hollow circle	$\frac{\pi(d^2 - d_1^2)}{4}$	$\frac{\pi(d^4 - d_1^4)}{64}$	$\frac{\pi(d^4 - d_1^4)}{32}$	$\frac{d^2 + d_1^2}{16}$	$\frac{d^4 - d_1^4}{10.2d}$	$\frac{d^4 - d_1^4}{5.1d}$

INDEX

- Axial force, 3.
- Bar, A compound, 165.
 Definition of, 3.
 of uniform strength, 22, 179.
- Beams, Compound, 163.
 Continuous, 109, 180.
 Deflection of, 102.
 Kinds of, 46.
 Maximum stress in, 156.
 of uniform strength, 66.
 Overhanging, 65.
 Reactions at the supports of, 47.
 Reënforced concrete, 166, 181.
 Relative strengths of, 64.
 Restrained or fixed, 105, 106, 107.
- Bending moment, in beams, 50, 178.
 Relation between vertical shear and, 63.
- Columns, Long, 123.
 Euler's formula for, 125, 180.
 Rankine's formula for, 131, 180.
- Compound bars and beams, 163.
- Compression combined with shear, 149.
 Formula for, 3, 178.
- Concrete beams, Reënforced, 166, 181.
- Continuous beams, 109, 180.
- Dangerous section in beams, 63.
- Deformation, of elastic bodies, 7.
 Unit, 7.
- Ductility, 11.
- Elastic Limit, 8.
 Commercial, 9.
- Elastic curve, 48, 99.
 Equation of the, 99, 179.
- Elasticity, Modulus of, 8, 178.
- Euler's formula for long columns, 125.
- Factors of safety, 14.
- Force, Internal and external, 6.
- Formula, Table of fundamental, 178.
 Table of derived, 179.
- Helical springs, 93.
- Horizontal shear in beams, 152.
- Load, Concentrated or uniform — on beams, 47.
 Eccentric axial — on beams, 148.
 Moving — on beams, 67.
- Materials, Constants of, 13, 183.
- Modulus of,
 Elasticity, Tension or compression, 8.
 Elasticity, Flexure, 102.
 Elasticity, Torsion, 88, 183.
 Rupture, Tension or compression, 3.
 Rupture, for beams, 55.
 Rupture, for torsion, 92.
 Section, Beams, 56.
 Section, Torsion, 86.
 for beams, 56.
- Moment, Bending, 50, 178.
 Diagram, 58.
 Resisting, 52.
- Neutral axis or plane, 53.
- Notation, Table of, 176.
- Pipes, Thin, strength of, 25, 179.
 Thick, strength of, 179, 27.
- Rankine's formula for long columns, 131.
- Reactions for beams, 47.
- Reënforced concrete beams, 166.
- Resilience, 10.
 Ultimate, 11.
 Elastic, 12.
- Riveted joints, 30.
 Compression in, 33, 179.
 Efficiency of, 37.

- Riveted joints (*continued*)
 General case of, 33.
 Kinds of, 35.
 Shear in, 32, 179.
 Tension in, 30, 179.
- Sections, Properties of, 184.
 Square — in Torsion, 86.
- Shafts, Couplings for, 90, 180.
 Horse power of, 89, 179.
 Strength and stiffness of, 89.
 Twist of, 88.
 Twisting moment in, 179.
- Shear, and axial stress, 149.
 Diagrams, 58, 59.
 Horizontal shear in beams, 152, 181.
 Resisting, 51.
 Vertical — in beams, 49, 179.
- Shearing stress, 5.
- Springs, Helical, 93, 180.
- Strength, Bars of uniform, 22, 179.
 of cylinders, pipes, and spheres, 25.
 of thick pipes, 27.
 Ultimate — of materials, 9.
- Stress, 3.
- Stress, Combined, 143, 180, 181.
 in roof rafters, 147.
- in long columns, 123.
 due to change of temperature, 39.
 Maximum — in beams, 63, 150.
 Maximum — tensile or compressive,
 5, 178.
 Shearing, 5, 178.
 Tensile or compressive, 4.
 Unit, 4.
 Working, 14.
- Tables: Constants of materials, 183.
 Derived formulas, 179.
 Fundamental formulas, 178.
 Notation, 176.
 Properties of beams, 182.
 Properties of sections, 184.
- Tension, combined with bending, 144.
 combined with shear, 149.
 Formula for, 3, 178.
- Torsion, Derivation of formula for, 83.
 Modulus of elasticity for, 183.
- Vertical shear, 49.
 Relation between the bending mo-
 ment and, 63.
- Yield point, 9.



STANDARD TEXT BOOKS

PUBLISHED BY

D. VAN NOSTRAND COMPANY,

NEW YORK.

- ABBOTT, A. V.** **The Electrical Transmission of Energy.** A Manual for the Design of Electrical Circuits. **Fifth Edition, entirely rewritten and enlarged.** Fully illustrated. 8vo, cloth.....net, \$5.00
- ASHE, S. W., and KEILEY, J. D.** **Electric Railways, Theoretically and Practically Treated. Vol. I, Rolling Stock. Second Edition, Revised.** 12mo, cloth. 290 pp., 172 illustrations.....net, \$2.50
- ASHE, S. W. Vol. II. Engineering Preliminaries and Direct Current Sub-Station.** 12mo, cloth. Illustrated.....net, \$2.50
- ATKINSON, A. A., Prof. Ohio University. Electrical and Magnetic Calculations,** for the use of Electrical Engineers and Artisans, Teachers, Students, and all others interested in the Theory and Application of Electricity and Magnetism. **Third edition, revised.** 12mo, cloth. Illustrated.....net, \$1.50
- **PHILIP. The Elements of Electric Lighting,** including Electric Generation, Measurement, Storage, and Distribution. **Tenth edition.** Illustrated. 12mo, cloth.....\$1.50
- **The Elements of Dynamic Electricity and Magnetism. Fourth edition.** 120 illustrations. 12mo, cloth.....\$2.00
- **Power Transmitted by Electricity, and its Application by the Electric Motor,** including Electric Railway Construction. **Fourth edition, fully revised, new matter added.** Illustrated. 12mo, cloth....\$2.00
- AUCHINCLOSS, W. S. Link and Valve Motions Simplified.** Illustrated with 29 wood-cuts, 20 lithographic plates, together with a Travel Scale, and numerous useful tables. **Fifteenth edition, revised.** 8vo, cloth.....\$1.50
- BARNARD, J. H. The Naval Militiaman's Guide.** Full leather, pocket size.....\$1.25
- BARRUS, G. H. Engine Tests: Embracing the Results of over one hundred feed-water tests and other investigations of various kinds of steam-engines,** conducted by the author. With numerous figures, tables, and diagrams. 8vo, cloth. Illustrated.....\$4.00
- BARWISE, S. M. The Purification of Sewage.** Being a brief account of the Scientific Principles of Sewage Purification and their Practical Application. 12mo, cloth. Illustrated. **New edition**.....net, \$3.50

- BEAUMONT, ROBERT.** **Color in Woven Design.** With 32 colored plates and numerous original illustrations. Thick 12mo, cloth.....\$7.50
- BEDELL, F.** **Direct and Alternating Current Testing.** Assisted by Clarence A. Pierce. Illustrated. 8vo, cloth, 250 pp.....net, \$2.00
- BEGTRUP, J., M.E.** **The Slide Valve and its Functions.** With Special Reference to Modern Practice in the United States. With numerous diagrams and figures. 8vo, cloth.....\$2.00
- BERNTHSEN, A.** **A Text-Book of Organic Chemistry.** Translated by George McGowan, Ph.D. **Fifth English Edition.** Revised and extended by the author and translator. Illustrated. 12mo, cloth...\$2.50
- BIGGS, C. H. W.** **First Principles of Electricity and Magnetism.** A book for beginners in practical work, containing a good deal of useful information not usually to be found in similar books. With numerous tables and 343 diagrams and figures. 12mo, cloth, illustrated.....\$2.00
- BLYTH, A. W.** **Foods: Their Composition and Analysis.** A Manual for the use of Analytical Chemists, with an Introductory Essay on the History of Adulterations. With numerous tables and illustrations. **Fifth edition, thoroughly revised, enlarged and rewritten.** 8vo, cloth.....\$7.50
- BODMER, G. R.** **Hydraulic Motors and Turbines.** For the use of Engineers, Manufacturers and Students. **Third edition, revised and enlarged.** With 192 illustrations. 12mo, cloth.....\$5.00
- BOWIE, AUG. J., Jr., M.E.** **A Practical Treatise on Hydraulic Mining in California.** With Descriptions of the Use and Construction of Ditches, Flumes, Wrought-iron Pipes and Dams; Flow of Water on Heavy Grades, and its Applicability, under High Pressure, to Mining. **Tenth edition.** Quarto, cloth. Illustrated.....\$5.00
- BOWSER, E. A., Prof.** **An Elementary Treatise on Analytic Geometry.** Embracing Plane Geometry, and an Introduction to Geometry of Three Dimensions. **Twenty-second edition,** 12mo, cloth.....\$1.75
- **An Elementary Treatise on the Differential and Integral Calculus.** With numerous examples. **Twenty-second edition,** enlarged by 640 additional examples. 12mo, cloth.....\$2.25
- **An Elementary Treatise on Analytic Mechanics.** With numerous examples. **Twentieth edition,** 12mo, cloth.....\$3.00
- **An Elementary Treatise on Hydro-Mechanics.** With numerous examples. **Sixth edition.** 12mo, cloth.....\$2.50
- **A Treatise on Roofs and Bridges.** With numerous Exercises. Especially adapted for school use. **Second edition.** 12mo, cloth. Illustrated. net, \$3.00
- BROWN, SIR HANBURY, K.C.M.G.** **Irrigation: Its Principles and Practice as a Branch of Engineering.** 8vo, cloth, 301 pp. Illustrated. net, \$5.00
- BRUCE, E. M., Prof.** **Pure Food Tests: the Detection of the Common Adulterants of Foods by simple Qualitative Tests.** A ready manual for Physicians, Health Officers, Food Inspectors, Chemistry Teachers, and all especially interested in the Inspection of Food. 12mo, cloth, illustrated. net, \$1.25

- BRUHNS, Dr.** **New Manual of Logarithms to Seven Places of Decimals. Seventh Edition.** 8vo, half morocco\$2.50
- CAIN, W., Prof.** **Brief Course in the Calculus.** With figures and diagrams. 8vo, cloth, illustrated.....net, \$1.75
- CARPENTER, R. C., Prof., and DIEDERICH, H., Prof.** **Internal Combustion Engines.** With figures and diagrams. 8vo, cloth, illustrated.....net, \$4.00
- CATHCART, WM. L., Prof.** **Machine Design. Part I. Fastenings.** 8vo, cloth. Illustrated.....net, \$3.00
- CHAMBERS' MATHEMATICAL TABLES, consisting of Logarithms of Numbers 1 to 108,000. Trigonometrical, Nautical and other Tables. New edition.** 8vo, cloth.....\$1.75
- CHRISTIE, W. WALLACE.** **Chimney Design and Theory.** A book for Engineers and Architects, with numerous half-tone illustrations and plates of famous chimneys. **Second edition, revised.** 8vo, cloth...\$3.00
- **Boiler Waters. Scale, Corrosion, Foaming.** 8vo, cloth. Illustrated.....net, \$3.00
- CORNWALL, H. B., Prof.** **Manual of Blow-pipe Analysis, Qualitative and Quantitative.** With a Complete System of Determinative Mineralogy. With many illustrations. 8vo, cloth.....\$2.50
- CROCKER, F. B., Prof.** **Electric Lighting.** A Practical Exposition of the Art, for Use of Engineers, Students, and others interested in the Installation or Operation of Electrical Plants. **Eighth edition, thoroughly revised and rewritten. Vol. I. The Generating Plant.** 8vo, cloth. Illustrated.....\$3.00
- **Vol. II. Distributing Systems and Lamps.** Sixth edition. 8vo, cloth. Illustrated.....\$3.00
- **and WHEELER, S. S.** **The Management of Electrical Machinery.** A thoroughly revised and enlarged edition of "The Practical Management of Dynamos and Motors." **Eighth edition, twenty-fourth thousand.** 131 illustrations. 12mo, cloth. .223 pp...net, \$1.00
- DINGER, H. C., Lieut., U.S.N.** **Handbook for the Care and Operation of Naval Machinery.** 16mo, cloth, illustrated.....net, \$2.00
- DORR, B. F.** **The Surveyor's Guide and Pocket Table-Book.** Seventh edition, revised, and greatly extended. With a second appendix up to date. 16mo, morocco, flaps.....\$2.00
- DRAPER, C. H.** **Heat, and the Principles of Thermodynamics.** With many illustrations and numerical examples. 12mo, cloth.....\$1.50
- ECCLES, Dr. R. G.** **Food Preservatives; their Advantages and Proper Use.** With an Introduction by E. W. Duckwall, M.S. 8vo, 202 pp., cloth.....\$1.00
 " Paper..... .50

- ELIOT, C. W., Prof., and STORER, F. H. A., Prof.** **Compendious Manual of Qualitative Chemical Analysis.** Revised with the co-operation of the authors, by Prof. William R. Nichols. Illustrated. **Twenty-second edition.** newly revised by Prof. W. B. Lindsay and F. H. Storer. 12mo, cloth.....\$1.50
- EVERETT, J. D.** **Elementary Text-Book of Physics.** Illustrated. **Seventh edition.** 12mo, cloth.....\$1.40
- EWING, A. J., Prof.** **The Magnetic Induction in Iron and other metals.** **Third edition, revised.** 159 illustrations. 8vo, cloth...\$4.00
- FANNING, J. T.** **A Practical Treatise on Hydraulic and Water-supply Engineering.** Relating to the Hydrology, Hydro-dynamics and Practical Construction of Water-works in North America. 180 illustrations. **Seventeenth edition, revised, enlarged,** and new tables and illustrations added. 650 pp. 8vo, cloth.....\$5.00
- FISH, J. C. L.** **Lettering of Working Drawings.** Thirteen plates, with descriptive text. Oblong, $9 \times 12\frac{1}{2}$, boards.....\$1.00
- FLEMING, J. A., Prof.** **The Alternate-current Transformer in Theory and Practice. Vol. I. The Induction of Electric Currents.** 611 pp. **New edition, illustrated.** 8vo, cloth.....\$5.00
- **Vol. II. The Utilization of Induced Currents.** Illustrated. 8vo, cloth.....\$5.00
- **Electrical Laboratory Notes and Forms, Elementary and Advanced.** 4to, cloth, illustrated.....\$5.00
- **A Handbook for the Electrical Laboratory and Testing Room. Vol. I. Equipment, Resistance, Current, Electromotive Force and Power Measurement.** 538 pages. Illustrated. 8vo, cloth...net, \$5.00
- **Vol. II. Meter, Lamp, Cable, Dynamo, Motor and Transformer Testing.** 650 pages. Illustrated. 8vo, cloth.....net, \$5.00
- FOSTER, H. A.** **Electrical Engineers' Pocket-Book.** With the Collaboration of Eminent Specialists. A handbook of useful data for Electricians and Electrical Engineers. With innumerable tables, diagrams, and figures. **Fifth edition, completely revised and enlarged.** Pocket size, flexible leather, elaborately illustrated with an extensive index and patent thumb index tabs. 1636 pp.....\$5.00
- FOX, WM., and THOMAS, C. W., M.E.** **A Practical Course in Mechanical Drawing.** With plates. **Third edition, revised.** 12mo, cloth.\$1.25
- GANT, L. W.** **Elements of Electric Traction, for Motormen and Others.** Illustrated. 217 pp., 8vo, cloth.....net, \$2.50
- GEIKIE, J.** **Structural and Field Geology, for Students of Pure and Applied Science.** With figures, diagrams, and half-tone plates. 8vo, cloth.....net, \$4.00
- GILLMORE, Q. A., Gen.** **Practical Treatise on the Construction of Roads, Streets, and Pavements.** **Tenth edition.** With 70 illustrations. 12mo, cloth.....\$2.00

- GOODEVE, T. M.** A Text-Book on the Steam-Engine. With a Supplement on Gas-Engines. Twelfth edition, enlarged. 143 illustrations. 12mo, cloth.....\$2.00
- GUNTHER, C. O., Prof.** Integration by Trigonometric and Imaginary Substitution. With an Introduction by J. Burkitt Webb. Illustrated. 12mo, cloth.....net, \$1.25
- GUY, A. E.** Experiments on the Flexure of Beams, resulting in the Discovery of New Laws of Failure by Buckling. Reprinted from the "American Machinist." With diagrams and folding plates. 8vo, cloth, illustrated. 122 pp.....net, \$1.25
- HAEDER, HERMAN, C. E.** A Handbook on the Steam-Engine. With especial reference to small and medium sized engines. Third English edition, re-edited by the author from the second German edition, and translated with considerable additions and alterations by H. H. P. Powles. Nearly 1100 illustrations. 12mo, cloth.....\$3.00
- HALE, W. J., Prof. (Univ. of Mich.)** Calculations of General Chemistry, with Definitions, Explanations, and Problems. 174 pp. 12mo, cloth.....net, \$1.00
- HALL, WM. S., Prof.** Elements of the Differential and Integral Calculus. Sixth edition, revised. 8vo, cloth. Illustrated....net, \$2.25
- **Descriptive Geometry; With Numerous Problems and Practical Applications.** Comprising an 8vo volume of text and a 4to Atlas of illustrated problems. Second edition. Two vols., cloth.....net, \$3.50
- HALSEY, F. A.** Slide-Valve Gears: an Explanation of the Action and Construction of Plain and Cut-off Slide-Valves. Illustrated. Eleventh edition, revised and enlarged. 12mo, cloth.....\$1.50
- HANCOCK, HERBERT.** Text-Book of Mechanics and Hydrostatics. With over 500 diagrams. 8vo, cloth.....\$1.75
- HAWKESWORTH, J.** Graphical Handbook for Reinforced Concrete Design. A series of plates, showing graphically, by means of plotted curves, the required design for slabs, beams, and columns under various conditions of external loading, together with practical examples showing the method of using each plate. 4to, cloth.....net, \$2.50
- HAY, A.** Alternating Currents; Their Theory, Generation, and Transformation. 8vo, cloth, illustrated.....net, \$2.50
- **Principles of Alternate-Current Working.** 12mo, cloth, illustrated.....\$2.00
- **An Introductory Course of Continuous Current Engineering** With 183 figures and diagrams. Illustrated. 327 pp. 8vo, cloth.
net, \$2.50
- HECK, R. C. H., Prof.** The Steam-Engine. Vol. I. The Thermodynamics and the Mechanics of the Engine. 8vo, cloth, 391 pp. Illustrated.....net, \$3.50
- **Vol. II. Form, Construction, and Working of the Engine.** The Steam-Turbine. 8vo, cloth. Illustrated.....net, \$5.00

- HERRMANN, GUSTAV.** *The Graphical Statics of Mechanism.* A Guide for the Use of Machinists, Architects, and Engineers; and also a Text-Book for Technical Schools. Translated and annotated by A. P. Smith, M.E. 7 folding plates. **Sixth edition.** 12mo, cloth.....\$2.00
- HIROI, I.** *Statically-Indeterminate Stresses in Frames Commonly Used for Bridges.* With figures, diagrams, and examples. 12mo, cloth, illustrated.....net, \$2.00
- HOPKINS, N. MONROE, Prof.** *Experimental Electrochemistry.* Theoretically and Experimentally Treated. 300 pp., Svo. Illustrated. net, \$3.00
- HOUGHTON, C. E.** *The Elements of Mechanics of Materials.* A text for students in engineering courses. Illustrated. 194 pp., 12mo, cloth.....net, \$2.00
- HUTCHINSON, R. W., Jr.** *Long Distance Electric Power Transmission: being a treatise on the Hydro-electric Generation of Energy; its Transformation, Transmission, and Distribution.* 12mo, cloth, illustrated, 345 pp.....net, \$3.00
- JAMIESON, ANDREW, C. E.** *A Text-Book on Steam and Steam-Engines, including Turbines and Boilers.* Specially arranged for the Use of Science and Art, City and Guilds of London Institute, and other Engineering students. **Fifteenth edition, revised.** Illustrated. 12mo, cloth. \$3.00
- *Elementary Manual on Steam, and the Steam-Engine.* Specially arranged for the Use of First-Year Science and Art, City and Guilds of London Institute, and other Elementary Engineering Students. **Twelfth edition.** 12mo, cloth.....\$1.50
- JANNETTAZ, EDWARD.** *A Guide to the Determination of Rocks: being an Introduction to Lithology.* Translated from the French by G. W. Plympton, Professor of Physical Science at Brooklyn Polytechnic Institute. **Second edition, revised.** 12mo, cloth.....\$1.50
- JOHNSTON, J. F. W., Prof., and CAMERON, Sir CHARLES.** *Elements of Agricultural Chemistry and Geology.* **Seventeenth edition,** 12mo, cloth.....\$2.60
- KAPP, GISBERT, C. E.** *Electric Transmission of Energy, and its Transformation, Subdivision, and Distribution.* A practical handbook. **Fourth edition, revised.** 12mo, cloth.....\$3.50
- KELLER, S. S., Prof.** *Mathematics for Engineering Students* (Carnegie Schools Textbook Series. 12mo, half leather, illustrated.)
 Algebra and Trigonometry, with a chapter on Vectors. 282 pp...net, \$1.75
 — Special Algebra Edition. 113 pp.....net, \$1.00
 — Plane and Solid Geometry, 212 pp.....net, \$1.25
 — Analytical Geometry and Calculus, 359 pp.....net, \$2.00
- KEMP, JAMES FURMAN, A.B., M.E.** *A Handbook of Rocks; for use without the microscope.* With a glossary of the names of rocks and other lithological terms. **Fourth edition, revised.** 8vo, cloth. Illustrated.....\$1.50

- KERSHAW, J. B. C. Electrometallurgy.** Illustrated. 303 pp. 8vo, cloth.....net, \$2.00
- KLEIN, J. F. Design of a High-Speed Steam-engine.** With notes diagrams, formulas, and tables. **Second edition, revised and enlarged.** 8vo, cloth. Illustrated. 257 pp.....net, \$5.00
- KNIGHT, A. M., Lieut.-Com., U.S.N. Modern Seamanship.** Illustrated with 136 full-page plates and diagrams. **Third edition, revised.** 8vo, cloth, illustrated.....net, \$6.00
Half morrocco.....\$7.50
- KOESTER, F. Steam-Electric Power Plants and their Construction.** A Practical Treatise on the Design of Central Light and Power Stations and their Economical Construction and Operation. 473 pp., 340 illustrations. 8vo, cloth.....net, \$5.00
- KRAUCH, C., Dr. Testing of Chemical Reagents for Purity.** Authorized translation of the Third Edition, by J. A. Williamson and L. W. Dupre. With additions and emendations by the author. 8vo, cloth, net, \$3.00
- LAMBORN, L. L. Cottonseed Products.** A Manual of the Treatment of Cottonseed for its Products and Their Utilization in the Arts. With tables, figures, full-page plates, and a large folding map. 8vo, cloth, illustrated.....net, \$3.00
- LANCHESTER, F. W. Aerodynamics: Constituting the First** Volume of a Complete Work on Aerial Flight. With Appendices on the Velocity and Momentum of Sound Waves, on the Theory of Soaring Flight, etc. With numerous diagrams and half-tones. Illustrated. 442 pp, 8vo, cloth.....net, \$6.00
- LASSAR-COHN, Dr. An Introduction to Modern Scientific Chemistry,** in the form of popular lectures suited to University Extension Students and general readers. Translated from the author's corrected proofs for the second German edition, by M. M. Pattison Muir, M.A. 12mo, cloth. Illustrated.....\$2.00
- LATTA, M. N. Handbook of American Gas-Engineering Practice.** With diagrams and tables. 8vo, cloth, illustrated, 460 pp..net, \$4.50
- LEEDS, C. C. Mechanical Drawing for Trade Schools. High School edition.** (Carnegie Technical Schools Textbooks.) Text and Plates. 4to, oblong cloth.....net, \$1.25
- **Mechanical Drawing for Trade Schools. Machinery Trades' edition.** 43 lessons in text and plates. 4to, oblong cloth, 150 pp. net, \$2.00
- LIVERMORE, V. P., and WILLIAMS, J. How to Become a Competent Motorman.** Being a Practical Treatise on the Proper Method of Operating a Street Railway Motor Car; also giving details how to overcome certain defects. **Revised edition, entirely rewritten and enlarged.** 16mo, cloth, illustrated.....\$1.00
- LODGE, OLIVER J. Elementary Mechanics,** including Hydrostatics and Pneumatics. **Revised edition.** 12mo, cloth.....\$1.50

- LUCKE, C. E.** *Gas Engine Design.* With figures and diagrams. Second edition, revised. 8vo, cloth, illustrated.....net, \$3.00
- LUNGE, G., Ph.D.** *Technical Chemists' Handbook.* Tables and methods of analysis for manufacturers of inorganic chemical products. 283 pp. 12mo, leather.....net, \$3.50
- LUQUER, LEA McILVAINE, Ph.D.** *Minerals in Rock Sections.* The Practical Method of Identifying Minerals in Rock Sections with the Microscope. Especially arranged for Students in Technical and Scientific Schools. Third edition, revised. 8vo, cloth. Illustrated....net, \$1.50
- MASSIE, W. W., and UNDERHILL, C. R.** *Wireless Telegraphy and Telephony Popularly Explained.* With a special article by Nikola Tesla. 76 pp. 28 illustrations. 12mo, cloth.....net, \$1.00
- MELICK, C. W., Prof.** *Dairy Laboratory Guide.* 12mo, cloth, illustrated.....net, \$1.25
- MERCK, E.** *Chemical Reagents: Their Purity and Tests.* 250 pp.....net, \$1.50
- MILLER, E. H.** *Quantitative Analysis for Mining Engineers.* Second edition, revised. 8vo, cloth.....net, \$1.50
- MINIFIE, WM.** *Mechanical Drawing. A Text-Book of Geometrical Drawing* for the use of Mechanics and Schools, in which the Definitions and Rules of Geometry are familiarly explained; the Practical Problems are arranged from the most simple to the more complex, and in their description technicalities are avoided as much as possible. With illustrations for Drawing Plans, Sections, and Elevations of Railways and Machinery; an Introduction to Isometrical Drawing, and an Essay on Linear Perspective and Shadows. Illustrated with over 200 diagrams engraved on steel. Tenth thousand. With an appendix on the Theory and Application of Colors. 8vo, cloth.....\$4.00
- MINIFIE, WM.** *Geometrical Drawing. Abridged from the Octavo Edition,* for the use of schools. Illustrated with 48 steel plates. Ninth edition. 12mo, cloth.....\$2.00
- MOSES, ALFRED J., and PARSONS, C. L.** *Elements of Mineralogy, Crystallography, and Blow-Pipe Analysis, from a Practical Standpoint.* 336 illustrations. Fourth edition. 8vo, cloth.....\$2.50
- NASMITH, JOSEPH.** *The Student's Cotton Spinning.* Thirteenth thousand, revised and enlarged. 8vo, cloth. Illustrated.....\$3.00
- NUGENT, E.** *Treatise on Optics; or, Light and Sight theoretically and practically treated, with the application to Fine Art and Industrial Pursuits.* With 103 illustrations. 12mo, cloth.....\$1.50
- OLSEN, Prof. J. C.** *Text-Book of Quantitative Chemical Analysis* by Gravimetric, Electrolytic, Volumetric, and Gasometric Methods. With seventy-two Laboratory Exercises giving the analysis of Pure Salts, Alloys, Minerals, and Technical Products. Fourth edition, revised and enlarged. 8vo, cloth. Illustrated. 513 pp.....net, \$4.00
- OLSSON, A.** *Motor Control as Used in Connection with Turret Turning and Gun Elevating.* (The Ward Leonard System.) Illustrated. 8vo, Pamphlet, 27 pp. (U. S. Navy Electrical Series, No. 1.).....net, \$5.00

- LOUDIN, MAURICE A.** **Standard Polyphase Apparatus and Systems.** With many diagrams and figures. **Sixth edition, thoroughly revised.** Fully illustrated. 8vo, cloth\$3.00
- PALAZ, A., Sc.D.** **A Treatise on Industrial Photometry,** with special application to Electric Lighting. Authorized translation from the French by George W. Patterson, Jr. **Second edition, revised.** 8vo, cloth. Illustrated.....\$4.00
- PARSHALL, H. F., and HOBART, H. M.** **Armature Windings of Electric Machines.** With 140 full-page plates, 65 tables, and 165 pages of descriptive letter-press. **Second edition.** 4to, cloth.....\$7.50
- **Electric Railway Engineering.** With numerous tables, figures, and folding plates. 4to, cloth, 463 pp., illustrated.....net, \$10.00
- PAULDING, CHAS, P.** **Practical Laws and Data on Condensation of Steam in Covered and Bare Pipes.** 12mo, cloth. Illustrated. 102 pages.....net, \$2.00
- **The Transmission of Heat through Cold-Storage Insulation.** Formulas, Principles, and Data relating to Insulation of every kind. A Manual for Refrigerating Engineers. 12mo, cloth. 41 pp. Illustrated. net, \$1.00
- PERRINE, F. A. C., A.M., D.Sc.** **Conductors for Electrical Distribution; Their Manufacture and Materials, the Calculation of the Circuits, Pole Line Construction, Underground Working and other Uses.** With diagrams and engravings. **Second edition, revised.** 8vo, cloth.....net, \$3.50
- PERRY, JOHN.** **Applied Mechanics. A Treatise for the Use of Students who have time to work experimental, numerical, and graphical exercises illustrating the subject.** **New edition, revised and enlarged.** 650 pages. 8vo, cloth.....net, \$2.50
- PLATTNER.** **Manual of Qualitative and Quantitative Analysis with the Blow-Pipe.** From the last German edition, revised and enlarged, by Prof. Th. Richter, of the Royal Saxon Mining Academy. Translated by Prof. H. B. Cornwall, assisted by John H. Caswell. Illustrated with 78 woodcuts. **Eighth edition, revised.** 463 pages. 8vo, cloth. net, \$4.00
- POPE, F. L.** **Modern Practice of the Electric Telegraph.** A Technical Handbook for Electricians, Managers, and Operators. **Seventeenth edition, rewritten and enlarged,** and fully illustrated. 8vo, cloth. \$1.50
- PRELINI, CHARLES.** **Tunneling.** A Practical Treatise containing 149 Working Drawings and Figures. With additions by Charles S. Hill, C.E., Associate Editor "Engineering News." **Third edition, revised.** 8vo, cloth. Illustrated.....\$3.00
- **Earth and Rock Excavation.** A Manual for Engineers, Contractors, and Engineering Students. **Second edition, revised.** 8vo, cloth. Illustrated. 350 pp.....net, \$3.00
- **Graphical Determination of Earth Slopes. Retaining Walls, and Dams.** 8vo, cloth, illustrated, 136 pp.....net, \$2.00

- PRESCOTT, A. B., Prof. Organic Analysis.** A Manual of the Descriptive and Analytical Chemistry of Certain Carbon Compounds in Common Use; a Guide in the Qualitative and Quantitative Analysis of Organic Materials in Commercial and Pharmaceutical Assays, in the Estimation of Impurities under Authorized Standards, and in Forensic Examinations for Poisons, with Directions for Elementary Organic Analysis. **Sixth edition.** 8vo, cloth. \$5.00
- and **SULLIVAN, E. C. First Book in Qualitative Chemistry.** Eleventh edition. 12mo, cloth. net, \$1.50
- and **OTIS COE JOHNSON. Qualitative Chemical Analysis.** A Guide in the Practical Study of Chemistry and in the Work of Analysis. **Sixth revised and enlarged edition, entirely rewritten.** with an Appendix by H. H. Willard containing a few improved methods of Analysis. 8vo, cloth. net, \$3.50
- RANKINE, W. J. MACQUORN, C.E., LL.D., F.R.S. Machinery and Mill-work.** Comprising the Geometry, Motions, Work, Strength, Construction, and Objects of Machines, etc. Illustrated with nearly 300 woodcuts. **Seventh edition.** Thoroughly revised by W. J. Millar. 8vo, cloth. \$5.00
- **The Steam-Engine and Other Prime Movers.** With diagram of the Mechanical Properties of Steam. With folding plates, numerous tables and illustrations. **Fifteenth edition.** Thoroughly revised by W. J. Millar. 8vo, cloth. \$5.00
- **Useful Rules and Tables for Engineers and Others.** With appendix, tables, tests, and formulæ for the use of Electrical Engineers. Comprising Submarine Electrical Engineering, Electric Lighting, and Transmission of Power. By Andrew Jamieson, C.E., F.R.S.E. **Seventh edition, thoroughly revised** by W. J. Millar. 8vo, cloth. \$4.00
- **A Mechanical Text-Book.** By Prof. Macquorn Rankine and E. E. Bamber, C.E. With numerous illustrations. **Fifth edition.** 8vo, cloth. \$3.50
- RANKINE, W. J. MACQUORN, C.E., LL.D., F.R.S. Applied Mechanics.** Comprising the Principles of Statics and Cinematics, and Theory of Structures, Mechanics, and Machines. With numerous diagrams. **Eighteenth edition.** Thoroughly revised by W. J. Millar. 8vo, cloth \$5.00
- **Civil Engineering.** Comprising Engineering, Surveys, Earthwork, Foundations, Masonry, Carpentry, Metal-Work, Roads, Railways, Canals, Rivers, Water-Works, Harbors, etc. With numerous tables and illustrations. **Twenty-third edition.** Thoroughly revised by W. J. Millar. 8vo, cloth. \$6.50
- RATEAU, A. Experimental Researches on the Flow of Steam** Through Nozzles and Orifices, to which is added a note on The Flow of Hot Water. Authorized translation by H. Boyd Brydon. 12mo, cloth. Illustrated. net, \$1.50
- RAUTENSTRAUCH, W., Prof., and WILLIAMS, J. T. Machine Drafting and Empirical Design.** A Textbook for Students in Engineering Schools and Others Who are Beginning the Study of Drawing as Applied to Machine Design. Part I. Machine Drafting. Illustrated, 70 pp., 8vo, cloth net, \$1.25
Complete in Two Parts. Part II in preparation.

- RAYMOND, E. B.** *Alternating Current Engineering Practically Treated.* **Third edition, revised and enlarged**, with an additional chapter on "The Rotary Converter." 12mo, cloth. Illustrated. 232 pages. net, \$2.50
- REINHARDT, CHAS. W.** *Lettering for Draughtsmen, Engineers and Students.* A Practical System of Free-hand Lettering for Working Drawings. New and revised edition. **Thirty-first thousand.** Oblong boards. \$1.00
- RICE, J. M., Prof., and JOHNSON, W. W., Prof.** *On a New Method of Obtaining the Differential of Functions, with especial reference to the Newtonian Conception of Rates of Velocities.* 12mo, paper. \$0.50
- RIPPER, WILLIAM.** *A Course of Instruction in Machine Drawing and Design for Technical Schools and Engineer Students.* With 52 plates and numerous explanatory engravings. **Second edition.** 4to, cloth. \$6.00
- ROBINSON, J. B.** *Architectural Composition.* An attempt to order and phrase ideas which hitherto had been only felt by the instinctive taste of designers. 233 pp., 173 illustrations. 8vo, cloth. net, \$2.50
- ROGERS, ALLEN.** *A Laboratory Guide of Industrial Chemistry.* Illustrated. 170 pp. 8vo, cloth. net, \$1.50
- SCHMALL, C. N.** *First Course in Analytic Geometry, Plane and Solid, with Numerous Examples.* Containing figures and diagrams. 12mo, half leather, illustrated. net, \$1.75
- and **SHACK, S. M.** *Elements of Plane Geometry.* An Elementary Treatise. With many examples and diagrams. 12mo, half leather, illustrated. net, \$1.25
- SEATON, A. E., and ROUNTHWAITE, H. M.** *A Pocket-book of Marine Engineering Rules and Tables.* For the Use of Marine Engineers and Naval Architects, Designers, Draughtsmen, Superintendents and all engaged in the design and construction of Marine Machinery, Naval and Mercantile. **Seventh edition, revised and enlarged.** Pocket size. Leather, with diagrams. \$3.00
- SEIDELL, A.** (Bureau of Chemistry, Wash., D. C.). *Solubilities of Inorganic and Organic Substances.* A handbook of the most reliable Quantitative Solubility Determinations. 8vo, cloth, 367 pp. . . . net, \$3.00
- SEVER, Prof. G. F.** *Electrical Engineering Experiments and Tests on Direct-Current Machinery.* With diagrams and figures. **Second edition, thoroughly revised and enlarged.** 8vo, pamphlet. Illustrated. net, \$1.00
- and **TOWNSEND, F.** *Laboratory and Factory Tests in Electrical Engineering.* **Second Edition, thoroughly revised and enlarged.** 8vo, cloth. Illustrated. 236 pages. net, \$2.50
- SHELDON, S., Prof., and MASON, HOBART, B.S.** *Dynamo Electric Machinery; its Construction, Design, and Operation.* Direct-Current Machines. **Seventh edition, revised.** 12mo, cloth. Illustrated. net, \$2.50

- SHELDON, S., MASON, H., and HAUSMANN, E.** **Alternating Current Machines.** Being the second volume of the authors' "Dynamo Electric Machinery; its Construction, Design, and Operation." With many diagrams and figures. (Binding uniform with volume I.) **Seventh edition, completely rewritten.** 12mo, cloth. Illustrated.....net, \$2.50
- SHIELDS, J. E.** **Notes on Engineering Construction.** Embracing Discussions of the Principles involved, and Descriptions of the Material employed in Tunneling, Bridging, Canal and Road Building, etc. 12mo, cloth.....\$1.50
- SHUNK, W. F.** **The Field Engineer. A Handy Book of Practice** the Survey, Location and Track-work of Railroads, containing a large collection of Rules and Tables, original and selected, applicable to both the standard and Narrow Gauge, and prepared with special reference to the wants of the young engineer. **Nineteenth edition, revised and enlarged.** With addenda. 12mo, morocco, tucks.....\$2.50
- SMITH, F. E.** **Handbook of General Instruction for Mechanics.** Rules and formulæ for practical men. 12mo, cloth, illustrated. 324 pp. net, \$1.50
- SOTHERN, J. W.** **The Marine Steam Turbine.** A practical description of the Parsons Marine Turbine as now constructed, fitted and run, intended for the use of students, marine engineers, superintendent engineers draughtsmen, works managers, foremen, engineers and others. **Third edition, rewritten up to date and greatly enlarged.** 180 illustrations and folding plates, 352 pp. 8vo, cloth.....net, \$5.00
- STAHL, A. W., and WOODS, A. T.** **Elementary Mechanism.** A Text-Book for Students of Mechanical Engineering. **Sixteenth edition, enlarged.** 12mo, cloth.....\$2.00
- STALEY, CADY, and PIERSON, GEO. S.** **The Separate System of Sewerage; its Theory and Construction.** With maps, plates, and illustrations. **Third edition, revised and enlarged,** with a chapter on "Sewage Disposal." 8vo, cloth.....\$3.00
- STODOLA, Dr. A.** **The Steam-Turbine.** With an appendix on Gas Turbines and the future of Heat Engines. Authorized Translation from the Second Enlarged and Revised German edition by Dr. Louis C. Loewenstein. 8vo, cloth. Illustrated. 434 pages.....net, \$4.50
- SUDBOROUGH, J. J., and JAMES, T. C.** **Practical Organic Chemistry.** 92 illustrations. 394 pp., 12mo, cloth.....net, \$2.00
- SWOOPE, C. WALTON.** **Practical Lessons in Electricity.** Principles, Experiments, and Arithmetical Problems. An Elementary Text-Book. With numerous tables, formulæ, and two large instruction plates. **Tenth edition.** 12mo, cloth. Illustrated.....net, \$2.00
- TITHERLEY, A. W., Prof.** **Laboratory Course of Organic Chemistry,** including Qualitative Organic Analysis. With figures. 8vo, cloth. Illustrated.....net, \$2.00
- THURSO, JOHN W.** **Modern Turbine Practice and Water-Power Plants.** **Second edition, revised.** 8vo, 244 pages. Illustrated. net, \$4.00

- TOWNSEND, F.** *Short Course in Alternating Current Testing.* 8vo, pamphlet. 32 pages.....net, \$0.75
- URQUHART, J. W.** *Dynamo Construction.* A practical handbook for the use of Engineer-Constructors and Electricians in charge, embracing Framework Building, Field Magnet and Armature Winding and Grouping, Compounding, etc., with examples of leading English, American, and Continental Dynamos and Motors. With numerous illustrations. 12mo, cloth.....\$3.00
- VAN NOSTRAND'S** *Chemical Annual, based on Biederman's "Chiemker Kalender."* Edited by Prof. J. C. Olsen, with the co-operation of Eminent Chemists. **Revised and enlarged.** Second issue 1909. 12mo, cloth.....net, \$2.50
- VEGA, Von (Baron).** *Logarithmic Tables of Numbers and Trigonometrical Functions.* Translated from the 40th, or Dr. Bremiker's thoroughly revised and enlarged edition, by W. L. F. Fischer, M.A., F.R.S. **Eighty-first edition.** 8vo, half morocco.....\$2.50
- WEISBACH, JULIUS.** *A Manual of Theoretical Mechanics. Ninth American edition.* Translated from the fourth augmented and improved German edition, with an Introduction to the Calculus by Eckley B. Coxe, A.M., Mining Engineer. 1100 pages, and 902 woodcut illustrations. 8vo, cloth.....\$6.00
Sheep.....\$7.50
- and **HERRMANN, G.** *Mechanics of Air Machinery.* Authorized translation with an appendix on American practice by Prof. A. Trowbridge. 8vo, cloth, 206 pages. Illustrated.....net, \$3.75
- WESTON, EDMUND B.** *Tables Showing Loss of Head Due to Friction of Water in Pipes. Fourth edition.* 12mo, full leather...\$1.50
- WILLSON, F. N.** *Theoretical and Practical Graphics.* An Educational Course on the Theory and Practical Applications of Descriptive Geometry and Mechanical Drawing. Prepared for students in General Science, Engraving, or Architecture. **Third edition, revised.** 4to, cloth, illustrated.....net, \$4.00
- *Descriptive Geometry, Pure and Applied, with a chapter on Higher Plane Curves, and the Helix.* 4to, cloth, illustrated.....net, \$3.00
- WILSON, GEO.** *Inorganic Chemistry, with New Notation. Revised and enlarged by H. G. Madan. New edition.* 12mo, cloth.....\$2.00
- WINCHELL, N. H., and A. N.** *Elements of Optical Mineralogy.* An introduction to microscopic petrography, with descriptions of all minerals whose optical elements are known and tables arranged for their determination microscopically. 354 illustrations. 525 pages. 8vo, cloth.....net, \$3.50
- WRIGHT, T. W., Prof.** *Elements of Mechanics, including Kinematics, Kinetics, and Statics. Seventh edition, revised.* 8vo, cloth....\$2.50
- and **HAYFORD, J. F.** *Adjustment of Observations by the Method of Least Squares, with applications to Geodetic Work. Second edition, rewritten.* 8vo, cloth, illustrated.....net, \$3.00
- ZEUNER, A., Dr.** *Technical Thermodynamics.* Translated from the Fifth, completely revised German edition of Dr. Zeuner's original treatise on Thermodynamics, by Prof. J. F. Klein, Lehigh University. 8vo, cloth, two volumes, illustrated, 900 pages.....net, \$8.00



**THIS BOOK IS DUE ON THE LAST DATE
STAMPED BELOW**

AN INITIAL FINE OF 25 CENTS

WILL BE ASSESSED FOR FAILURE TO RETURN
THIS BOOK ON THE DATE DUE. THE PENALTY
WILL INCREASE TO 50 CENTS ON THE FOURTH
DAY AND TO \$1.00 ON THE SEVENTH DAY
OVERDUE.

MAR 8 1942

SEP 8 1947

MAY 1 1948

MAY 5 1948

LD 21-100m-7,'40 (6936s)

part
750 m

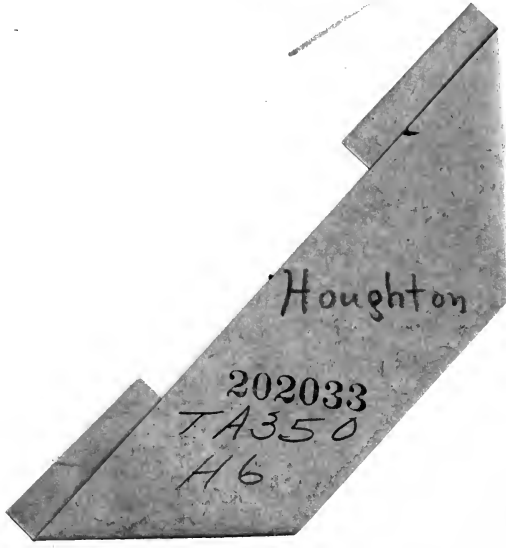

Houghton

202033
TA350
H6

