

W. F. Meyer

GIFT OF
the estate of
Professor William F. Meyer

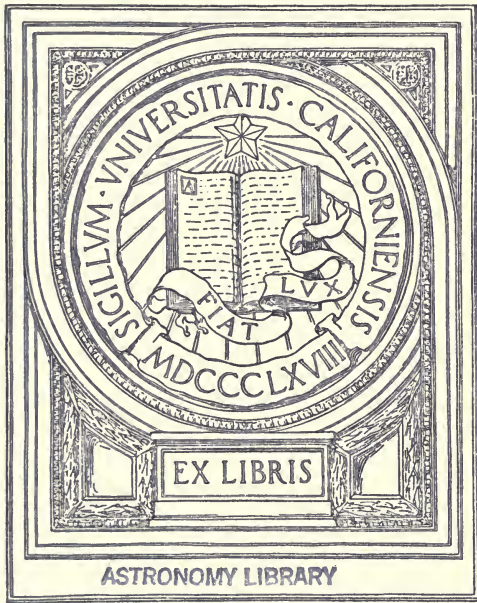

W. F. Meyer.



Digitized by the Internet Archive
in 2007 with funding from
Microsoft Corporation



THE ELEMENTS
OF
PLANE AND SOLID
ANALYTIC GEOMETRY

BY

ALBERT L. CANDY, PH.D.

ASSISTANT PROFESSOR OF MATHEMATICS IN THE UNIVERSITY
OF NEBRASKA

BOSTON, U.S.A.

D. C. HEATH & CO., PUBLISHERS

1904

Astronomy
Add to Lib

COPYRIGHT, 1904,
BY D. C. HEATH & Co.

Meyer gift

QA 551
C 2
Astron.
Lib.

PREFACE

ANALYTIC GEOMETRY is a broader subject than Conic Sections. It is far more important to the student that he should acquire a good knowledge of the analytic method, that he should comprehend the generality of its processes, and learn how to interpret its results, than that he should obtain a detailed knowledge of the properties of any particular set of curves. Furthermore, there is a certain interrelation, or interdependence, between the various branches of elementary mathematics. Experience in teaching these subjects has convinced me that, on the ground of expediency alone, this interdependence should be recognized in the class room. In the study of mathematics, as well as in its applications, Algebra and Geometry, Analytics and Calculus, are mutually helpful. Hence these branches should not be studied entirely apart. As all these branches, or at least more than one, must finally be used in the complete solution of many problems, there seems to be no good reason why the student should not be taught to do this as soon as possible.

For these reasons a fuller treatment than usual is given of the general analytic method before taking up the study of the conic sections, and subjects have been introduced that are not ordinarily included in text-books on Analytic Geometry. The method of the Differential Calculus is the only way of studying the slope of curves, and furnishes the best means for finding the equation of the tangent and the normal. The graphical method of illustration and the derivative are indispensable in the study of the Theory of Equations. The use of the *Derivative Curve* in the theory of equal roots, together with the fact that the ordinate of the derivative curve is the slope of the *Integral Curve*, naturally suggests a possible converse relation, and leads easily and logically and with no difficult transition to the study of Quadrature and Maxima and Minima.

It is believed that the elementary treatment of these subjects here given will tend to meet the needs of scientific and technical students, who now require a knowledge of the graphical method and the simpler elements of the Calculus at the earliest possible moment; and that it will also be helpful to the general student who pursues the study of mathematics no farther. Moreover, in the

secant method of finding the equation of the tangent, the reasoning is essentially the same as in the method here used, but the student seldom or never comprehends its significance. And, furthermore, he never uses the method save in the case of the conic sections, whereas the *derivative method* is one that he can always use.

The subjects discussed in Chapter VI need not be taken at the time or in the order in which they occur in the book. Or, if the teacher prefers to pursue the old established method of teaching each branch of mathematics exclusively, he may, at his discretion, omit this entire chapter without interfering in any way with the continuity of his course. While this book has been in preparation, my own plan has been (with students who have not previously had the Theory of Equations) to give in substance the theorems contained in §§ 63-71 immediately after the work on curve tracing, or symmetry. The remainder can be given any time after Chapter V has been read.

In finding the equations of loci, special emphasis is given to the meaning of the parameters which appear in the final equations, and the significance of a variation in their value, and a full discussion and a thorough geometric interpretation of the result are rigidly insisted on from the beginning. *The teacher should never lose sight of this vital principle.*

Polar coordinates and their relations to rectangular coordinates have been introduced at the very beginning.

The conic section is first briefly studied geometrically. Its defining property is proved in this way, from which its general equation is shown to be of the second degree. The two central conics are treated simultaneously by using the double sign in the standard equation. In this way much time is saved, and the similarities of the properties of the two conics are presented in a striking manner.

As the book is intended for beginners, numerous illustrative examples are given in the first part on Plane Geometry, and also a large number of exercises. The numerical examples have all been prepared especially for this book. Answers are given to only a few of these, as it is far better to check results in such exercises by constructing an accurate figure. A unique feature in the way of exercises is found in the list of *Miscellaneous Problems on Loci* that occur in the phenomena of everyday life. These cover a wide range of subjects and should be of interest to students in any department. The study of mathematics should not only develop the power of investigation, but should also cultivate the habit of carefully examining interesting phenomena. I hope these problems will help toward the accomplishment of these ends, and at the same time tend to bridge over the chasm between the theoretical and the practical. They are

placed at the end of Part I, so that they may be assigned at any time without seeming to have been passed over.

The theory of the second part on Solid Geometry is somewhat fuller, and the examples are considerably more extensive both as to number and character, than is usually the case in elementary books. The chief new feature that has been introduced is the use of the notion of *Contour Lines* in the tracing of surfaces. This idea, as well as the whole subject of *surface tracing*, has not hitherto been sufficiently emphasized.

Where the proof in Solid Geometry is the same as in the corresponding proposition in Plane Geometry the demonstration has not always been repeated. In two instances, viz. § 154 and § 169, an entirely different method of proof has been used. This has not been done simply for the sake of variety, although this would be a sufficient reason, but *because the algebraic results obtained in this way admit of a much broader interpretation*. The student should be required, as an exercise, to apply these methods of proof to the corresponding propositions in Plane Geometry, and *vice versa*. As a suggestion to this end, appropriate references are given in all these sections. If this is done, the student will be able to prove for himself the harmonic properties of the conic section.

I have put two small sections, I and II, in the Appendix rather than assign them to any particular place in the body of the text. The method of finding the direction of a curve at the origin, given in I, I have found to be helpful as early as in the section on curve plotting in Chapter II. If used at all, it should at least precede the formal study of slope.

I wish to thank most heartily all my colleagues in this university who have aided me so kindly in the work, and to acknowledge my special obligation to Professor Ellery W. Davis, who, from the inception of the plan to the completion of the book, has given me much valuable assistance. I am also much indebted to Professor George D. Olds, of Amherst College, and Professor E. V. Huntington, of Harvard University, who have read the entire manuscript with great care and offered many helpful suggestions.

A. L. C.

THE UNIVERSITY OF NEBRASKA,
May 25, 1904.

CONTENTS

PART I. PLANE GEOMETRY

CHAPTER I

COORDINATES, DISTANCES, AND AREAS

SECTIONS		PAGE
1-4.	Cartesian coordinates. <i>Exercises</i>	1
5.	Polar coordinates. <i>Exercises</i>	5
6.	Relations between rectangular and polar coordinates. <i>Exercises</i> .	7
7-9.	Distance between two points	8
10-13.	Areas of polygons	12
	Examples on Chapter I	16

CHAPTER II

LOCI AND THEIR EQUATIONS

14-20.	Illustrative examples and definitions	18
21-22.	Plotting loci of equations. <i>Exercises</i>	23
23.	Use of graphic methods. <i>Illustrations</i>	28
24-26.	Intersection of loci. <i>Exercises</i>	32
27-29.	Symmetry of loci. <i>Exercises</i>	34
30-37.	Finding the equations of loci. <i>Exercises</i>	38

CHAPTER III

THE STRAIGHT LINE

38-49.	Standard forms of the equations in rectangular and polar coordinates. <i>Exercises</i>	46
50-51.	Equations of the straight line in oblique coordinates. <i>Exercises</i> .	62
	Examples on Chapter III	63

CHAPTER IV

TRANSFORMATION OF COORDINATES

SECTIONS		PAGE
53.	To move the origin to the point (h, k)	67
54.	To turn rectangular axes through an angle θ	68
	Examples on Chapter IV	69

CHAPTER V

SLOPE, TANGENTS, AND NORMALS

55-56.	Examples of limiting values of ratios. <i>Exercises</i>	70
58.	Geometric meaning of the derivative of the function $f(x)$	72
59.	Illustrative examples of derivatives. <i>Exercises</i>	74
60-61.	General formulæ for differentiation	76
62.	Tangents and normals	78
	Examples on Chapter V	78

CHAPTER VI

THEORY OF EQUATIONS, QUADRATURE, AND MAXIMA AND MINIMA

63-80.	Theory of equations. <i>Exercises</i>	82
81.	Quadrature. <i>Exercises</i>	101
82.	Maxima and minima. <i>Exercises</i>	105

CHAPTER VII

CONIC SECTIONS

85.	Geometric proof of the defining property of the conic section	113
86.	Classification of the conic sections. <i>Exercises</i>	116
87.	General equation of the conic sections	117
88-91.	Standard equations of the conic sections	119
92-93.	Tangents	126
94-95.	Pole and polar. <i>Exercises</i>	128

CHAPTER VIII

THE PARABOLA

96-100.	Properties of the parabola $y^2 = 4ax$. <i>Exercises</i>	131
	Examples on Chapter VIII.	136

CONTENTS

ix

CHAPTER IX

THE CIRCLE

SECTIONS	PAGE
101-106. Properties of the circle. <i>Exercises</i>	139
Examples on Chapter IX	146

CHAPTER X

THE ELLIPSE AND HYPERBOLA

107-108. Tangent, polar, and normal	150
109. Geometric properties. <i>Exercises</i>	152
110-111. Conjugate hyperbola, and director circle	155
112-114. Auxiliary circle and eccentric angle. <i>Exercises</i>	157
115. Asymptotes — definition and equations	162
116-117. Similar and coaxial conics — diameters	164
118-121. Conjugate diameters. <i>Exercises</i>	168
122-123. Equation referred to asymptotes, and polar equation	174
Examples on Chapter X	175

CHAPTER XI

GENERAL EQUATION OF THE SECOND DEGREE

124-126. To transform the general equation to the standard forms	179
Examples on Chapter XI	187
Examples on loci	188
Miscellaneous problems on loci	189

PART II. SOLID GEOMETRY

CHAPTER XII

SYSTEMS OF COORDINATES, THE POINT, RECTANGULAR COORDINATES

127-130. Rectangular coordinates. <i>Exercises</i>	193
131. Polar coordinates and direction cosines	197
132. Spherical coordinates	198
133. Cylindrical coordinates. <i>Exercises</i>	199

CHAPTER XIII

Loci

SECTIONS		PAGE
134-135.	The locus (in space) of an equation is a surface	200
136-139.	To trace the locus of an equation. Contour lines. <i>Exercises</i>	202
140.	To find the equation of a locus	205
141.	Surfaces of revolution. <i>Exercises</i>	206

CHAPTER XIV

THE PLANE AND THE STRAIGHT LINE

142-143.	The plane. <i>Exercises</i>	209
144-149.	The straight line. <i>Exercises</i>	211
150-151.	Transformation of coordinates	216
	Examples on Chapter XIV	218

CHAPTER XV

CONICOIDS

152-155.	The sphere. <i>Exercises</i>	220
156-157.	The cone	224
158.	The ellipsoid	227
159.	The hyperboloid of one sheet	229
160.	The asymptotic cone of the hyperboloid of one sheet	231
161.	The hyperboloid of two sheets	232
162.	The elliptic paraboloid.	234
163.	The hyperbolic paraboloid	235
164.	The paraboloids the limiting forms of the central conicoids. <i>Exercises</i>	237
165-168.	Tangent planes and normals	238
169-170.	Poles and polar planes	241
	Examples on Chapter XV	243

APPENDIX

I.	The direction of a curve at the origin	245
II.	Example illustrating § 81	246
III.	Trigonometrical formulæ	248

ANALYTIC GEOMETRY

CHAPTER I

COORDINATES, LENGTHS OF LINES, AND AREAS OF POLYGONS

RECTILINEAR COORDINATES

1. Let $X'X$ and $Y'Y$ be two fixed, non-parallel straight lines, intersecting in the point O . Let P be any point in the plane of these lines. Draw RP and QP parallel to $X'X$ and $Y'Y$ respectively.

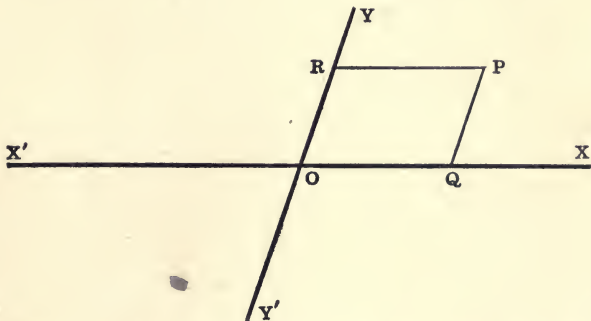

These distances, RP and QP , determine the place of P within the angle XOY . That is, to every position of P there is one and only one pair of distances, to every pair of distances one and only one position of P . Moreover, the position of P can be found when the lengths of the lines RP and QP are given, and *vice versa*.

Suppose, for example, that we are given $RP = a$, $QP = b$, we need only measure $OQ = a$ and $OR = b$ and draw the parallels RP and QP , which will intersect in the required point.

2. The two lines RP and QP , or OQ and OR , which thus determine the position of the point P with reference to the lines

$X'X$ and $Y'Y$ are called the **Rectilinear** or **Cartesian*** **Coordinates** of the point P . QP is called the **Ordinate** of the point P , and is denoted by the letter y ; RP , or its equal OQ , the intercept cut off by the ordinate, is called the **Abscissa**, and is denoted by the letter x .

The fixed lines $X'X$ and $Y'Y$ are called the **Axes of Coordinates**, and their point of intersection O is called the **Origin**. When the angle between the axes of coordinates is oblique, the axes, and also the coordinates, are said to be **Oblique**; when the angle between the axes is right, the axes and the coordinates are said to be **Rectangular**.

If $OQ = a$ and $OR = b$, then at P , $x = a$ and $y = b$; at Q , $x = a$ and $y = 0$; at R , $x = 0$ and $y = b$; and at O , $x = 0$ and $y = 0$.

The axis $X'X$ is called the **Axis of Abscissas**, or the **x-axis**; and $Y'Y$ is called the **Axis of Ordinates** or the **y-axis**.

3. Let OQ and OQ' be equal in *magnitude* to a , and let OR and OR' be equal in *magnitude* to b . Through Q , Q' , R , and R' draw lines parallel to the axes, and intersecting in P_1 , P_2 , P_3 , P_4 .

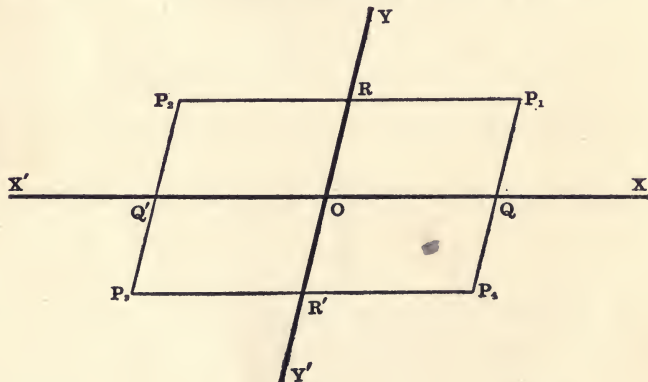

Now at all of these four points $x = a$, in *magnitude*, and $y = b$, in *magnitude*. Hence in order that the equations $x = a$ and $y = b$

* This method of determining the position of a point in a plane is due to the French philosopher and mathematician, Descartes. Hence the name *Cartesian*. The new method was first published in 1637.

"It is frequently stated that Descartes was the first to apply algebra to geometry. This statement is inaccurate, for Vieta and others had done this before him. Even the Arabs sometimes used algebra in connection with geometry. The new step that Descartes did take was the introduction into geometry of an analytical method based

shall determine *only one* point, it is not sufficient to know the *lengths* of a and b , we must also know the *directions* in which they are measured.

In order to indicate the directions of lines we adopt the rule that *opposite directions shall be indicated by opposite signs*. It is agreed, as in Trigonometry, that distances measured in the directions OX (or to the right) and OY (or upwards) shall be considered *positive*. Hence distances measured in the directions OX' (or to the left) and OY' (or downwards) *must* be considered *negative*. Therefore (assuming a and b to be positive numbers)

$$\begin{aligned} &\text{at } P_1, x = a, y = b; \text{ at } P_2, x = -a, y = b; \\ &\text{at } P_3, x = -a, y = -b; \text{ at } P_4, x = a, y = -b. \end{aligned}$$

Thus the four points are easily and clearly distinguished, for no two *pairs* of values of x and y are the same.

If all possible values, positive and negative, be given to x and to y , *i.e.*, if both x and y be made to vary independently from $-\infty$ to $+\infty$, all points in the plane will be obtained. Moreover, to each *pair of values* of x and y there corresponds, in all the plane, *one and only one* point; to each point, one and only one pair of values.

4. For the sake of brevity, a point is represented by writing its coordinates within a parenthesis, the *abscissa* being always written *first*. Thus, in the preceding figure, P_1, P_2, P_3, P_4 , are the points $(a, b), (-a, b), (-a, -b), (a, -b)$, respectively. In general, the point whose coordinates are x and y is called the point (x, y) .

When the axes are rectangular it is convenient to distinguish the parts into which the axes divide the plane as first, second, third, and fourth quadrants, as in Trigonometry.

Because of simplicity in formulæ and equations, it is *generally more convenient* to use rectangular axes.

on the notion of variables and constants, which enabled him to represent curves by algebraic equations. In the Greek geometry, the idea of motion was wanting, but with Descartes it became a very fruitful conception. By him a point on a plane was determined in position by its distances from two fixed right lines or axes. These distances varied with every change of position in the point. This geometric idea of *coordinate representation*, together with the algebraic idea of *two variables in one equation* having an indefinite number of simultaneous values, furnished a method for the study of loci, which is admirable for the generality of its solutions. Thus the entire conic sections of Apollonius is wrapped up and contained in a single equation of the second degree." [A History of Mathematics by Florian Cajori, p. 185.]

Accordingly, throughout this book, except when the contrary is expressly stated, the axes may be assumed rectangular.

EXAMPLES

1. In what quadrants must a point lie if its coordinates have the same sign? different signs?
2. Locate the points $(1, -3)$, $(-2, 4)$, $(5, 0)$, $(-1, -3)$, $(4, 2)$, $(0, 3)$.
3. Construct the triangle whose vertices are the points $(0, 4)$, $(-5, -1)$, and $(4, -3)$.
4. Construct the triangle whose vertices are $(4, -1)$, $(1, 2)$, $(-1, -3)$.
5. Construct the quadrilateral whose vertices are the points $(3, 4)$, $(-1, 4)$, $(-1, -2)$, $(3, -2)$. What kind of a quadrilateral is it? Consider both oblique and rectangular axes.
6. Plot the points $(8, 0)$, $(5, 4)$, $(0, 4)$, $(-3, 0)$, $(0, -4)$, $(5, -4)$, and connect them by straight lines. What kind of a figure do these six lines enclose?
7. P is the point (x, y) ; P_1 , P_2 , P_3 are its symmetrical points with respect to the x -axis, y -axis, and origin, respectively. What are the coordinates of P_1 , P_2 , P_3 ?
8. The side of a square is $2a$. What are the coordinates of its vertices when the diagonals are the axes?
9. The side of an equilateral triangle is $2a$. What are the coordinates of its vertices, if one vertex is at the origin and one side coincides with the x -axis?
10. Where may a point be if its abscissa is 2? if its ordinate is -3 ?
11. Can a point move and yet always satisfy the condition $x = 0$? $y = 0$? both the conditions $x = 0$ and $y = 0$?
12. How must a point move so as to satisfy the condition $x = c$? $y = d$? both these conditions, c being a negative and d a positive number?
13. If a point moves along either of the bisectors of the angles between the axes, what is the relation between its coordinates?
14. Where may a point be if its coordinates satisfy the condition $x^2 + y^2 = a^2$? What is the relation between the coordinates of a point which moves so that its distance from the origin is always 2?
15. If a line AB is two units to the left of the y -axis, what are the coordinates of a point whose distance from AB is three units?
16. If P be any point on the bisector of the angle between the y -axis and a line three units above the x -axis, what is the general relation between the coordinates of P ?

POLAR COORDINATES

5. Let O be a fixed point called the **Pole**, and OX a fixed line called the **Initial Line**.

Take any other point P in the plane and draw OP . The position of the point P with reference to the line OX is known when the distance OP and the angle XOP are given.

The line OP is called the **Radius Vector** of the point P , and will be denoted by ρ ; the angle XOP , which the radius vector makes with the initial line, is called the **Vectorial Angle** of the point P , and will be denoted by θ .

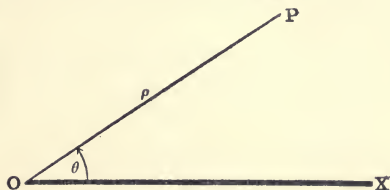

Then ρ and θ are the **Polar Coordinates*** of P ; that is, P is the point (ρ, θ) . As in Trigonometry, it is agreed that the angle θ shall be positive when measured from OX counter clockwise; that ρ shall be positive when measured in the direction of the terminal line of the vectorial angle θ .

In determining the position of a point whose polar coordinates are given the following direction will be useful: Suppose I stand at O facing in the direction of OX . To get to the point (ρ, θ) , I turn through the angle θ to the *left* or *right* according as θ is *positive* or *negative*, then, keeping my new facing, I go a distance ρ *forward* or *backward* according as ρ is *positive* or *negative*. †

* Whenever the position of a point in a plane is determined by any two magnitudes whatever, these two magnitudes are the coordinates of the point. Thus there may be an indefinite number of systems of coordinates. For an explanation of other systems which are in common use see Chap. I of Elements of Analytical Geometry by Briot and Bouquet, translated by J. H. Boyd.

† This method of locating points by means of coordinates is not altogether new to the student, neither is it confined to mathematics. For example, when we locate places on the surface of the earth by means of their latitude and longitude, we make use of a *system of rectangular coordinates* in which the axes are the equator and some chosen meridian. When we say the city B is forty miles north-east of the city A, we locate B with reference to A by means of a *system of polar coordinates* in which the initial line is the meridian through A, and A is the pole. Let the student suggest other familiar examples, if possible. How are places located in cities? in Washington, D.C.?

EXAMPLES

Plot on one diagram the following points :

1. $(4, 30^\circ)$, $(-3, 135^\circ)$, $(3, 120^\circ)$, $(-4, -30^\circ)$.
2. $(5, 45^\circ)$, $(-4, 120^\circ)$, $(3, -150^\circ)$, $(-6, -240^\circ)$.
3. $(a, \frac{1}{4}\pi)$, $(-a, \frac{1}{6}\pi)$, $(a, -\frac{3}{4}\pi)$, $(2a, -\frac{2}{3}\pi)$, $(-\frac{1}{2}a, -\frac{1}{3}\pi)$, $(a, 0)$, $(2a, \pi)$.
4. $(5, \tan^{-1}5)$, $(-2, \tan^{-1}2)$, $(3, -\tan^{-1}3)$, $(-4, \tan^{-1}-1)$.
5. $(a, \tan^{-1}2)$, $(a, -\tan^{-1}3)$, $(-a, \tan^{-1}\frac{1}{2})$, $(-a, -\tan^{-1}\frac{1}{3})$, $[a, \tan^{-1}(-4)]$.

6. Plot the points $(-6, 30^\circ)$, $(2, 150^\circ)$, $(2, -90^\circ)$ and connect them by straight lines. What kind of a figure do these lines enclose?

7. Plot the points $(a, 60^\circ)$, $(b, 150^\circ)$, $(a, 240^\circ)$, $(b, -30^\circ)$, and join them by straight lines. What kind of a figure do these lines enclose?

8. Find the polar coordinates of the vertices of a square whose angular points in rectangular coordinates are $(3, -1)$, $(-1, -1)$, $(-1, 3)$, $(3, 3)$.

9. The side of an equilateral triangle is $2a$. If one vertex is at the pole, and one side coincides with the initial line, what are the polar coordinates of its vertices? of the middle points of the sides?

10. Change "equilateral triangle" to "square" in Ex. 9.

11. Change "equilateral triangle" to "regular hexagon" in Ex. 9.

12. How must ρ and θ vary in order to obtain all points in the plane? (See § 3.)

13. Show that to each pair of values of ρ and θ there corresponds in all the plane one and only one point.

14. Show by plotting the four points, $(3, 60^\circ)$, $(-3, 240^\circ)$, $(3, -300^\circ)$, $(-3, -120^\circ)$, that the converse of Ex. 13 is not true.

15. Show that in general the same point is given by each of the four pairs of polar coordinates,

$$(\rho, \theta), (-\rho, \pi + \theta), [\rho, -(2\pi - \theta)], [-\rho, -(\pi - \theta)].$$

16. Show that for all integral values of n the same point (ρ, θ) is also given by

$$(\rho, \theta \pm 2n\pi) \text{ and } [-\rho, \theta \pm (2n + 1)\pi].$$

17. Where does the point (ρ, θ) lie if $\theta = 0$? if $\theta = \pi$? if $\rho = 2$?

18. How can the point (ρ, θ) move if $\theta = \alpha$? if $\rho = a$? where α and a are constants?

19. What condition must ρ and θ satisfy if the point (ρ, θ) moves along a line perpendicular to the initial line? parallel to the initial line?

20. What is the position of the point (ρ, θ) if $\rho = a \cos \theta$? $\rho = a \sin \theta$?

RELATIONS BETWEEN RECTANGULAR AND POLAR COORDINATES

6. Let P be any point whose rectangular coordinates are x and y , and whose polar coordinates, referred to O as pole and OX as initial line, are ρ and θ .

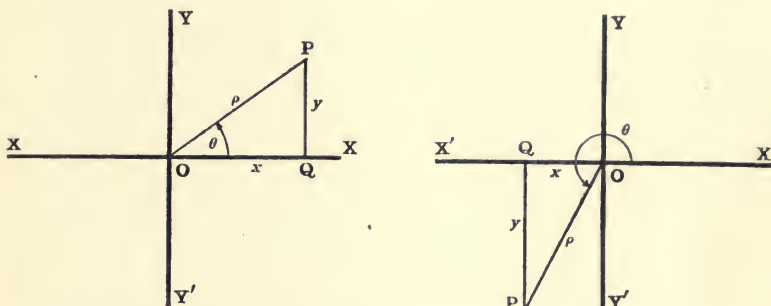

Draw PQ perpendicular to OX .

Then, according to the preceding definitions,

$$OQ = x, \quad QP = y, \quad OP = \rho, \quad \angle XOP = \theta.$$

From the right triangle PQO we have

$$OQ = OP \cos XOP \quad \text{and} \quad QP = OP \sin XOP.$$

$$\left. \begin{aligned} \therefore x &= \rho \cos \theta. \\ y &= \rho \sin \theta. \\ x^2 + y^2 &= \rho^2. \end{aligned} \right\} \quad (1)$$

These equations (1) express the rectangular coordinates in terms of the polar coordinates.

From equations (1) we find the corresponding equations expressing the polar coordinates in terms of the rectangular coordinates to be

$$\left. \begin{aligned} \rho &= \sqrt{x^2 + y^2}, & \theta &= \tan^{-1} \frac{y}{x}, \\ \sin \theta &= \frac{y}{\sqrt{x^2 + y^2}}, & \cos \theta &= \frac{x}{\sqrt{x^2 + y^2}}. \end{aligned} \right\} \quad (2)$$

By means of formulæ (1) and (2) equations in *either* system of coordinates can be changed into the *other* system of coordinates. It is seldom necessary, however, to use equations (2).

EXAMPLES

1. Change the equation $\rho^2 = a^2 \cos 2\theta$ to rectangular coordinates.

Multiplying the equation by ρ^2 , and putting $\cos 2\theta = \cos^2\theta - \sin^2\theta$ gives

$$\rho^4 = a^2(\rho^2 \cos^2\theta - \rho^2 \sin^2\theta).$$

Whence by substituting equations (1) we have

$$(x^2 + y^2)^2 = a^2(x^2 - y^2).$$

Change to polar coordinates the equations

2. $x^2 + y^2 = 2rx$. Ans. $\rho = 2r \cos \theta$. 3. $x^2 - y^2 = a^2$. Ans. $\rho^2 = a^2 \sec 2\theta$.

4. $(2x^2 + 2y^2 - ax)^2 = a^2(x^2 + y^2)$. Ans. $\rho^{\frac{1}{2}} = a^{\frac{1}{2}} \cos \frac{1}{2}\theta$.

Transform to rectangular coordinates

5. $\rho^2 \sin 2\theta = 2a^2$. Ans. $xy = a^2$. 6. $\rho^{\frac{1}{2}} \cos \frac{1}{2}\theta = a^{\frac{1}{2}}$. Ans. $y^2 + 4ax = 4a^2$.

DISTANCE BETWEEN TWO POINTS

7. To find the distance between two points whose rectilinear coordinates are given.

Let $P_1(x_1, y_1)$ and $P_2(x_2, y_2)$ be the given points, and let the axes be inclined at an angle ω .

Draw P_1Q_1 and P_2Q_2 parallel to OY , to meet OX in Q_1 and Q_2 .

Draw P_2R parallel to OX to meet P_1Q_1 in R .

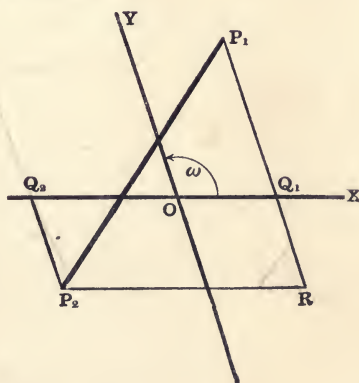
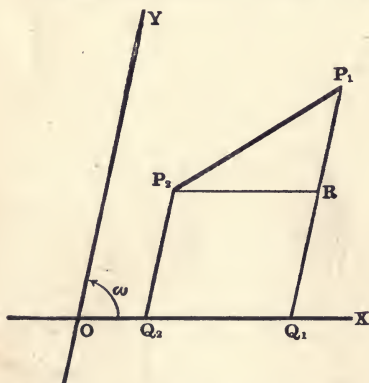

Then $OQ_1 = x_1$, $OQ_2 = x_2$, $Q_1P_1 = y_1$, $Q_2P_2 = y_2$.

$\therefore P_2R = Q_2Q_1 = OQ_1 - OQ_2 = x_1 - x_2$,

and $RP_1 = Q_1P_1 - Q_1R = Q_1P_1 - Q_2P_2 = y_1 - y_2$.

Also $\angle P_2RP_1 = \angle OQ_1P_1 = \pi - \omega$.

From the triangle P_1RP_2 we have, by the law of cosines,

$$P_2P_1^2 = P_2R^2 + RP_1^2 - 2P_2R \cdot RP_1 \cos (\pi - \omega).$$

Whence by substitution, since $\cos (\pi - \omega) = -\cos \omega$,

$$P_2P_1 = [(x_1 - x_2)^2 + (y_1 - y_2)^2 + 2(x_1 - x_2)(y_1 - y_2) \cos \omega]^{\frac{1}{2}}. \quad (1)$$

When the axes are rectangular, $\omega = 90^\circ$ and $\cos \omega = 0$.

Hence for the distance between two points whose rectangular coordinates are given, we have the very useful formula

$$P_2P_1 = \sqrt{(x_1 - x_2)^2 + (y_1 - y_2)^2}. \quad (2)$$

If the plus sign before the radicals in (1) and (2) gives P_2P_1 , the minus sign will give P_1P_2 . It will aid the memory to observe that the meaning of (2) is expressed by writing

$$(\text{Distance})^2 = (\text{Easting})^2 + (\text{Northing})^2.$$

COR. If P_2 coincides with the origin $x_2 = y_2 = 0$, and equations (1) and (2) give for the distance of a point $P_1(x_1, y_1)$ from the origin

$$OP_1 = \sqrt{x_1^2 + y_1^2 + 2x_1y_1 \cos \omega}, \text{ for oblique axes,} \quad (3)$$

$$OP_1 = \sqrt{x_1^2 + y_1^2}, \text{ for rectangular axes.} \quad (4)$$

EXAMPLES

1. Find the distance between $(-5, 3)$ and $(7, -2)$.
2. Show that if the axes are inclined at an angle of 60° , the distance between the points $(-3, 3)$ and $(4, -2)$ is $\sqrt{39}$.
3. Find the distance from the origin to the point $(-2, 4)$ when the axes are inclined at angle of 120° .
4. Find the lengths of the sides of the triangle whose vertices are $(4, 1)$, $(-2, 4)$, and $(1, -2)$.
5. Show that the four points $(2, 4)$, $(1, 7)$, $(-2, 4)$, and $(-1, 1)$ are the angular points of a parallelogram.
6. If the point (x, y) is 5 units distant from the point $(3, 4)$, then will $x^2 + y^2 - 6x - 8y = 0$.

* The student should convince himself of the generality of equations (1) and (2) by constructing other special cases in which the given points lie in different quadrants. He will thus have an illustration of the general principle that formulæ and equations deduced by considering points lying in the first quadrant, where both coordinates are positive, must, from the nature of the analytic method, hold true when the points are situated in any quadrant.

8. The distance between two points in terms of their polar coordinates.

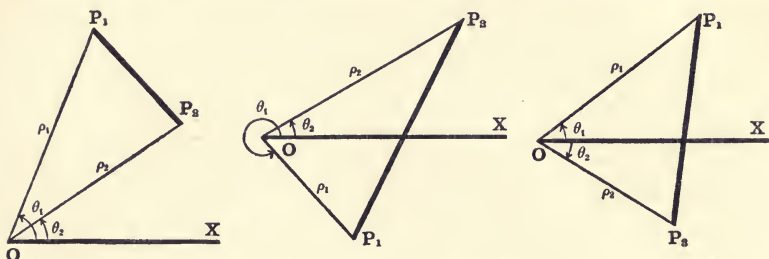

Let $P_1(\rho_1, \theta_1)$ and $P_2(\rho_2, \theta_2)$ be the two given points.

Then $OP_1 = \rho_1$, $OP_2 = \rho_2$, $\angle XOP_1 = \theta_1$, $\angle XOP_2 = \theta_2$,
and $\angle P_2OP_1 = \theta_1 - \theta_2$.

From the triangle P_1OP_2 , as in § 7, we have

$$P_1P_2^2 = OP_1^2 + OP_2^2 - 2 OP_1 \cdot OP_2 \cos P_2OP_1,$$

$$\therefore P_1P_2 = \sqrt{\rho_1^2 + \rho_2^2 - 2 \rho_1 \rho_2 \cos(\theta_1 - \theta_2)}. \quad (1)$$

Ex. 1. Derive equation (2), § 7, from equation (1), § 8.

Expanding the last term and squaring (1), § 8, gives

$$P_1P_2^2 = \rho_1^2 + \rho_2^2 - 2(\rho_1 \cos \theta_1)(\rho_2 \cos \theta_2) - 2(\rho_1 \sin \theta_1)(\rho_2 \sin \theta_2).$$

Substituting the values given in equations (1), § 6, we have

$$P_1P_2^2 = x_1^2 + y_1^2 + x_2^2 + y_2^2 - 2x_1x_2 - 2y_1y_2.$$

$$\therefore P_1P_2 = \sqrt{(x_2 - x_1)^2 + (y_2 - y_1)^2}.$$

Ex. 2. Show that the distance between the points $(4, 90^\circ)$ and $(-3, 30^\circ)$, is $\sqrt{37}$.

Ex. 3. Find the distance between $(2a, 180^\circ)$ and $(-a, 45^\circ)$.

9. To find the coordinates of the point which divides the line joining two given points in a given ratio ($m_1 : m_2$).

Let $P_1(x_1, y_1)$ and $P_2(x_2, y_2)$ be the two given points, and let $P(x, y)$ be the required point.

Draw P_1Q_1 , PQ , P_2Q_2 parallel to the y -axis, and PR , P_1R_1 parallel to the x -axis.

$$\text{Then} \quad P_1R_1 = x - x_1, \quad PR = x_2 - x,$$

$$R_1P = y - y_1, \quad RP_2 = y_2 - y.$$

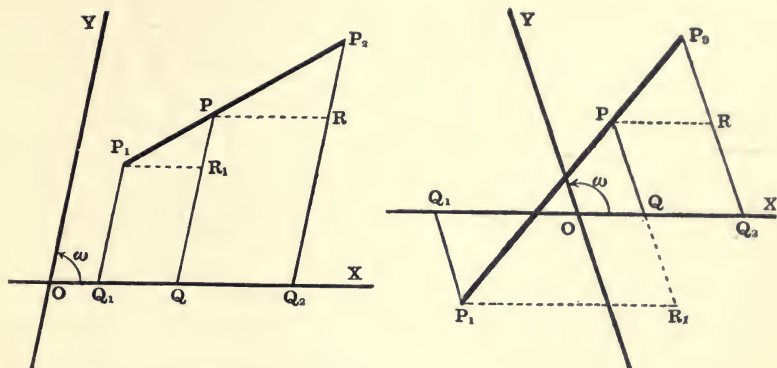

From the similar triangles P_1PR_1 and PP_2R , we have

$$\frac{P_1P}{PP_2} = \frac{P_1R_1}{PR} = \frac{R_1P}{RP_2} = \frac{m_1}{m_2} = \frac{x - x_1}{x_2 - x} = \frac{y - y_1}{y_2 - y}$$

$$\therefore m_1(x_2 - x) = m_2(x - x_1), \quad (1)$$

and

$$m_1(y_2 - y) = m_2(y - y_1). \quad (2)$$

Solving (1) and (2) for x and y , respectively, we obtain

$$x = \frac{m_1x_2 + m_2x_1}{m_1 + m_2}, \quad y = \frac{m_1y_2 + m_2y_1}{m_1 + m_2}. \quad (3)$$

If we let $\lambda = m_1 : m_2$, equations (3) reduce to the form

$$x = \frac{x_1 + \lambda x_2}{1 + \lambda}, \quad y = \frac{y_1 + \lambda y_2}{1 + \lambda}. \quad (4)$$

These equations, (3) or (4), cover all cases, the division being *internal* or *external* according as λ is *positive* or *negative*.

If P be the middle point of P_1P_2 , $m_1 = m_2$, and therefore the coordinates of the middle of a line joining two given points are

$$x = \frac{1}{2}(x_1 + x_2), \quad y = \frac{1}{2}(y_1 + y_2). \quad (5)$$

These formulæ, (3), (4), (5), are independent of the angle between the axes, and hold for both rectangular and oblique axes.

Ex. 1. Find the points which divide the line joining $(2, 5)$ and $(-5, -2)$ internally in the ratio $3 : 4$, and externally in the ratio $2 : 9$.

Ex. 2. In what ratio is the line joining the points $(2, 1)$ and $(-8, 6)$ divided by the point $(-2, 3)$? by the point $(8, -2)$?

AREAS OF POLYGONS

10.* To find the area of a triangle in terms of the coordinates of its vertices, the axes being inclined at an angle ω .

CASE I. When one vertex is at the origin.

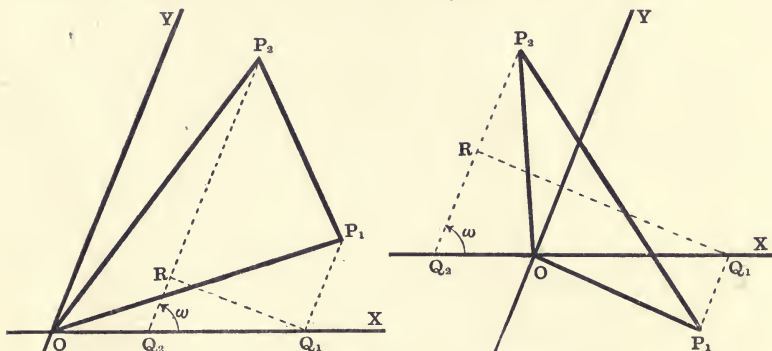

Let $P_1(x_1, y_1)$, $P_2(x_2, y_2)$ be the other two vertices. Draw P_1Q_1 , P_2Q_2 parallel to the y -axis, and Q_1R perpendicular to P_2Q_2 .

Then $OQ_1 = x_1$, $OQ_2 = x_2$, $Q_1P_1 = y_1$, $Q_2P_2 = y_2$,

$RQ_1 = Q_2Q_1 \sin \omega = (x_1 - x_2) \sin \omega$, and

$$\begin{aligned} \Delta OP_1P_2 &= \Delta OQ_2P_2 + \text{trap. } Q_2Q_1P_1P_2^* - \Delta OQ_1P_1, \\ &= \frac{1}{2} [OQ_2 \cdot Q_2P_2 + Q_2Q_1(Q_2P_2 + Q_1P_1) - OQ_1 \cdot Q_1P_1] \sin \omega, \\ &= \frac{1}{2} [x_2y_2 + (x_1 - x_2)(y_1 + y_2) - x_1y_1] \sin \omega, \\ &= \frac{1}{2} (x_1y_2 - x_2y_1) \sin \omega = \frac{1}{2} \begin{vmatrix} x_1 & y_1 \\ x_2 & y_2 \end{vmatrix} \sin \omega \end{aligned} \quad (1)$$

in the notation of determinants.

* The area of the trapezoid $ABCD$, in which the non-parallel sides intersect, is the *difference* of the areas of the two triangles formed by the diagonal AC . That is, $ABCD = ABC - ADC = ABE - CDE$.

This is expressed analytically by saying that the area is the *algebraic sum* of the triangles. The base CD is then regarded as changing its direction (and sign) with reference to AB ; for in going along the sides consecutively in the order $ABCD A$, the base CD is traversed in the same direction as AB , which is not the case in the ordinary trapezoid. That is, when D is to the left of C , both the base CD and the area of the triangle ACD are positive, say.

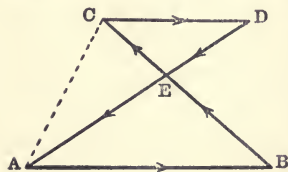

But as D moves to the right, both CD and the area ACD become zero and change sign as D passes through C .

CASE II. When the origin is not a vertex of the given triangle.

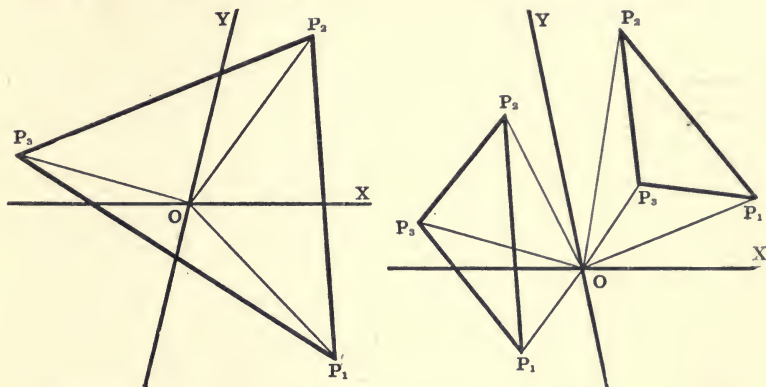

Let $P_1(x_1, y_1)$, $P_2(x_2, y_2)$, $P_3(x_3, y_3)$ be the vertices of the given triangle. Draw the lines OP_1 , OP_2 , OP_3 . Then by Case I we have

$$\Delta OP_1P_2 = \frac{1}{2}(x_1y_2 - x_2y_1) \sin \omega = \frac{1}{2} \begin{vmatrix} x_1 & y_1 \\ x_2 & y_2 \end{vmatrix} \sin \omega.$$

$$\Delta OP_2P_3 = \frac{1}{2}(x_2y_3 - x_3y_2) \sin \omega = \frac{1}{2} \begin{vmatrix} x_2 & y_2 \\ x_3 & y_3 \end{vmatrix} \sin \omega.$$

$$\Delta OP_3P_1 = \frac{1}{2}(x_3y_1 - x_1y_3) \sin \omega = \frac{1}{2} \begin{vmatrix} x_3 & y_3 \\ x_1 & y_1 \end{vmatrix} \sin \omega.$$

$$\therefore \Delta P_1P_2P_3 = \frac{1}{2}[(x_1y_2 - x_2y_1) + (x_2y_3 - x_3y_2) + (x_3y_1 - x_1y_3)] \sin \omega \quad (2)$$

$$= \frac{1}{2} \left\{ \begin{vmatrix} x_1 & y_1 \\ x_2 & y_2 \end{vmatrix} + \begin{vmatrix} x_2 & y_2 \\ x_3 & y_3 \end{vmatrix} + \begin{vmatrix} x_3 & y_3 \\ x_1 & y_1 \end{vmatrix} \right\} \sin \omega$$

$$= \frac{1}{2} \begin{vmatrix} x_1 & y_1 & 1 \\ x_2 & y_2 & 1 \\ x_3 & y_3 & 1 \end{vmatrix} \sin \omega. \quad (3)$$

When the axes are rectangular $\sin \omega = 1$, and equations (1), (2), (3), respectively, reduce to

$$\Delta OP_1P_2 = \frac{1}{2}(x_1y_2 - x_2y_1) = \frac{1}{2} \begin{vmatrix} x_1 & y_1 \\ x_2 & y_2 \end{vmatrix}. \quad (4)$$

$$\Delta P_1P_2P_3 = \frac{1}{2}(x_1y_2 - x_2y_1 + x_2y_3 - x_3y_2 + x_3y_1 - x_1y_3) \quad (5)$$

$$= \frac{1}{2} \begin{vmatrix} x_1 & y_1 & 1 \\ x_2 & y_2 & 1 \\ x_3 & y_3 & 1 \end{vmatrix} = \frac{1}{2} \begin{vmatrix} x_1 - x_2 & y_1 - y_2 \\ x_2 - x_3 & y_2 - y_3 \end{vmatrix}. \quad (6)$$

11.* When the origin is within the given triangle, the given triangle includes the three triangles OP_1P_2 , OP_2P_3 , OP_3P_1 (§ 10); hence the expressions $\frac{1}{2}(x_1y_2 - x_2y_1)$, $\frac{1}{2}(x_2y_3 - x_3y_2)$, and $\frac{1}{2}(x_3y_1 - x_1y_3)$ must have the *same sign*. When the origin is outside, the given triangle does not include all of these triangles, and therefore the above expressions can *not* have the *same sign*.

Suppose a person to start from O and walk consecutively around the triangles OP_1P_2 , OP_2P_3 , OP_3P_1 in the direction indicated by this order of vertices. This imaginary person would thus walk along each side of the given triangle *once* in the *same* direction around the figure, as indicated by $P_1P_2P_3$, and along each of the lines OP_1 , OP_2 , OP_3 , *twice* in *opposite* directions. When the origin is inside the given triangle, he would walk around each of these triangles in such a manner that he would have *its area always on his left hand*. When the origin is outside, he would go around those triangles which include *no part of the given triangle*, in such a manner that he would have *their area always on his right hand*.

Thus direction around a triangle may be taken to indicate the *sign* of its area. (See footnote under § 10.)

The expressions for area in § 10 will be found to be *positive*, if the vertices are numbered so that in passing around in the direction thus indicated *the area is always on the left*.

Let the student show by trial that $(x_1y_2 - x_2y_1)$ is \pm according as $\angle P_1OP_2$ is \pm ; $\angle P_1OP_2$ is \pm according as the cycle OP_1P_2 is \pm .

12.* *To express the area of a triangle in terms of the polar coordinates of its vertices.*

Let $P_1(\rho_1, \theta_1)$, $P_2(\rho_2, \theta_2)$, $P_3(\rho_3, \theta_3)$ be the three vertices.

Then $x_1 = \rho_1 \cos \theta_1$, $x_2 = \rho_2 \cos \theta_2$, $x_3 = \rho_3 \cos \theta_3$,

$y_1 = \rho_1 \sin \theta_1$, $y_2 = \rho_2 \sin \theta_2$, $y_3 = \rho_3 \sin \theta_3$. [(1), § 6.]

Substituting these values in (5) and (6) of § 10 gives

$$OP_1P_2 = \frac{1}{2} \rho_1 \rho_2 (\sin \theta_2 \cos \theta_1 - \cos \theta_2 \sin \theta_1) = \frac{1}{2} \rho_1 \rho_2 \sin (\theta_2 - \theta_1). \quad (1)$$

$$P_1P_2P_3 = \frac{1}{2} [\rho_1 \rho_2 \sin (\theta_2 - \theta_1) + \rho_2 \rho_3 \sin (\theta_3 - \theta_2) + \rho_3 \rho_1 \sin (\theta_1 - \theta_3)]. \quad (2)$$

From (1) it follows that the three terms of (2) represent, respectively, the areas of the triangles OP_1P_2 , OP_2P_3 , and OP_3P_1 .

The signs of these terms are the signs of the *angle differences* (since ρ can always be made positive), and we therefore have an independent proof of the statements in § 11.

Let the student prove (1) and (2) directly from a figure.

13.* *To find the area of any polygon when the rectangular coordinates of its vertices are known.*

Let $P_1(x_1, y_1)$, $P_2(x_2, y_2)$, $P_3(x_3, y_3)$, $P_4(x_4, y_4) \dots P_n(x_n, y_n)$ be the n vertices of the given polygon. Then, we have, from (5) § 10,

$$\Delta OP_1P_2 = \frac{1}{2} \begin{vmatrix} x_1 & y_1 \\ x_2 & y_2 \end{vmatrix}, \quad \Delta OP_2P_3 = \frac{1}{2} \begin{vmatrix} x_2 & y_2 \\ x_3 & y_3 \end{vmatrix},$$

$$\Delta OP_3P_4 = \frac{1}{2} \begin{vmatrix} x_3 & y_3 \\ x_4 & y_4 \end{vmatrix}, \quad \Delta OP_4P_5 = \frac{1}{2} \begin{vmatrix} x_4 & y_4 \\ x_5 & y_5 \end{vmatrix},$$

.....

$$\Delta OP_nP_1 = \frac{1}{2} \begin{vmatrix} x_n & y_n \\ x_1 & y_1 \end{vmatrix}.$$

$$\therefore \text{Area } P_1P_2 \dots P_n = \frac{1}{2} \left\{ \begin{vmatrix} x_1 & y_1 \\ x_2 & y_2 \end{vmatrix} + \begin{vmatrix} x_2 & y_2 \\ x_3 & y_3 \end{vmatrix} + \begin{vmatrix} x_3 & y_3 \\ x_4 & y_4 \end{vmatrix} \right. \\ \left. + \begin{vmatrix} x_4 & y_4 \\ x_5 & y_5 \end{vmatrix} + \dots + \begin{vmatrix} x_n & y_n \\ x_1 & y_1 \end{vmatrix} \right\}, \quad (1)$$

since the area of the polygon is the *algebraic* sum of the areas of these triangles. This formula is easy to remember, but by expanding the determinants and collecting the positive and negative terms it may be written,

$$\text{Area } P_1P_2 \dots P_n = \frac{1}{2} [(x_1y_2 + x_2y_3 + x_3y_4 + \dots x_ny_1) \\ - (y_1x_2 + y_2x_3 + y_3x_4 + \dots y_nx_1)], \quad (2)$$

which gives the following simple rule for finding the area of a polygon when the rectangular coordinates of its vertices are known:

- (1) *Number the vertices consecutively, keeping the area on the left.*
- (2) *Multiply each abscissa by the next ordinate.*
- (3) *Multiply each ordinate by the next abscissa.*
- (4) *From the sum of the first set of products subtract the sum of the second set and take half of the result.*

If the axes are oblique, the second members of (1) and (2) must be multiplied by the sine of the angle between the axes.

The law of the *sign* of the area is the same as for the triangle.

EXAMPLES ON CHAPTER I

Find the area of the polygons the coordinates of whose vertices taken in order are, respectively,

1. $(1, 3)$, $(-2, -4)$, and $(3, -1)$.
2. $(2, 5)$, $(-6, -2)$, and $(-1, 5)$, when $\omega = 60^\circ$.
3. $(4, 15^\circ)$, $(-5, 45^\circ)$, and $(6, 75^\circ)$.
4. $(3, -30^\circ)$, $(-5, 150^\circ)$, and $(4, 210^\circ)$.
5. $(2, 15^\circ)$, $(6, 75^\circ)$, and $(5, 135^\circ)$.
6. $(-a, \frac{1}{3}\pi)$, $(a, \frac{1}{2}\pi)$, and $(-2a, -\frac{2}{3}\pi)$.
7. $(a, b+c)$, $(a, b-c)$, and $(-a, c)$.
8. $(a, c+a)$, (a, c) , and $(-a, c-a)$.
9. $(2, 3)$, $(-1, 4)$, $(-5, -2)$, and $(3, -2)$.
10. $(4, 5)$, $(1, 4)$, $(-2, 6)$, $(-5, 3)$, $(-2, -1)$, $(-3, -4)$, $(1, -2)$, $(3, -4)$, and $(2, 1)$.
11. What are the rectangular coordinates of $(4, 30^\circ)$, $(-2, 135^\circ)$, $(-3, \frac{3}{8}\pi)$?
12. What are the polar coordinates of $(3, -4)$, $(-5, 12)$, $(1, 3)$?
13. Find the coordinates of the points which trisect the line joining the points $(-2, -1)$ and $(3, 2)$.
14. Find the coordinates of the point which divides the line joining $(3, -2)$ and $(-5, 4)$ internally in the ratio $3:4$.
15. Find the coordinates of the point which divides the line joining $(5, 3)$ and $(-1, 4)$ externally in the ratio $3:2$.
16. Find the length of the sides and medians of the triangle $(2, 6)$, $(7, -6)$, $(-5, -1)$. What kind of a triangle is it?
17. Find the length of the sides and the area of the triangle $(3, 4)$, $(-1, 0)$, $(2, -3)$. What kind of a triangle is it?
18. Find the sides and area of the quadrilateral whose vertices taken in order are $(5, -1)$, $(-1, 2)$, $(-5, 0)$, and $(1, -3)$. What kind of a quadrilateral is it?

Change to polar coordinates the equations

19. $x^2 + y^2 = r^2$.

20. $y = x \tan \alpha$.

21. $x^3 = y^2(2a - x)$.

22. $(x^2 + y^2)(x - a)^2 = b^2x^2$.

Transform to Cartesian coordinates

23. $\theta = \tan^{-1} m$.

24. $\rho^2 = a^2 \sec 2\theta$.

25. $\rho = a \sin 2\theta$.

26. $\rho^{\frac{1}{2}} = a^{\frac{1}{2}} \sin \frac{1}{2}\theta$.

Prove analytically the following theorems :

- ✓ 27. The diagonals of a parallelogram bisect each other.
28. The lines joining the middle points of the adjacent sides of any quadrilateral form a parallelogram.
- ✓ 29. The three medians of a triangle meet in a point, which is one of their points of trisection.
30. The lines joining the middle points of opposite sides of any quadrilateral and the line joining the middle points of its diagonals meet in a point and bisect one another.
- ✓ 31. The area of the triangle formed by joining the middle points of the sides of a given triangle is equal to one-fourth of the area of the given triangle.
32. If in any triangle a median be drawn from the vertex to the base, the sum of the squares of the other two sides is equal to twice the square of half the base plus twice the square of the median.
- ✓ 33. The sum of the squares of the four sides of any quadrilateral is equal to the sum of the squares of the diagonals plus four times the square of the line joining the middle points of the diagonals.
34. $P_1(x_1, y_1)$, $P_2(x_2, y_2)$, $P_3(x_3, y_3)$, $P_4(x_4, y_4)$. . . $P_n(x_n, y_n)$ are any n points in a plane. P_1P_2 is bisected at Q_1 ; Q_1P_3 is divided at Q_2 in the ratio 1:2; Q_2P_4 is divided at Q_3 in the ratio 1:3; Q_3P_5 at Q_4 in the ratio 1:4, and so on till all the points are used. Show that the coordinates of the final point so obtained are

$$\frac{x_1 + x_2 + x_3 + x_4 + \dots + x_n}{n} \quad \text{and} \quad \frac{y_1 + y_2 + y_3 + y_4 + \dots + y_n}{n}.$$

Show that the result is independent of the order in which the points are taken.

[This point is called the *Centre of Mean Position* of the n given points.]

CHAPTER II

LOCI AND THEIR EQUATIONS

14. It has been shown in § 3 that to each pair of values of x and y there corresponds in all the plane one and only one point, and that to each point corresponds one and only one pair of values. Also, if x and y vary independently and unconditionally from $-\infty$ to ∞ , every point in the plane will be obtained.

If, on the contrary, one or both of the coordinates cannot take all values, or if all values cannot be independently taken by both, the point cannot move to all positions in the plane.

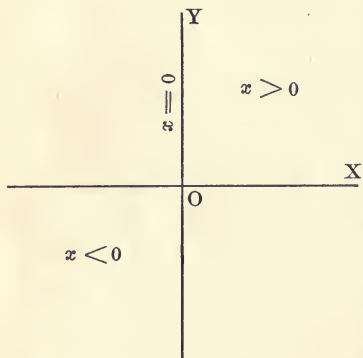

If, for example, $x > 0$, the point (x, y) must lie to the *right* of the y -axis; if $x < 0$, the point must lie to the *left* of the y -axis; if x is neither *greater* nor *less* than zero, the point can lie neither to the *right* nor to the *left* of the y -axis; *i.e.* if $x = 0$, the point must lie *on* the y -axis.

15. If $x > a$, the point (x, y) must lie to the *right* of the parallel AB , which is a units to the right of the y -axis; if $x < a$, the point must lie to the *left* of AB . Therefore, if $x = a$, the point will lie *on* the line AB .

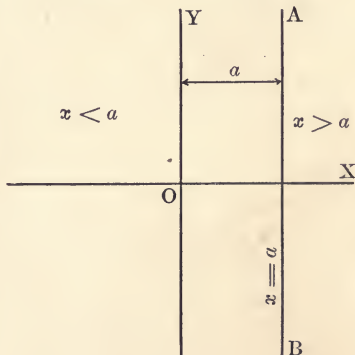

Ex. 1. Where will the point (x, y) lie if $x > -3$? $x < -3$? $x = -3$?

Ex. 2. Where is the point (x, y) if $y > b$? $y < b$? $y = b$? $y > -b$? $y < -b$? $y = -b$?

16. Draw a circle with centre at the origin and radius equal to a .

Then the point $P(x, y)$ will be outside, inside, or on this circle according as

$$OP > a, \quad OP < a, \quad \text{or} \quad OP = a.$$

$$\text{But } OP^2 = x^2 + y^2. \quad [(4), \S 7.]$$

Therefore the point $P(x, y)$ is outside, inside, or on the circle, according as

$$x^2 + y^2 > a^2, \quad x^2 + y^2 < a^2, \quad \text{or} \quad x^2 + y^2 = a^2.$$

Ex. 1. Write down the conditions that the point (x, y) shall be outside, inside, or on the circle whose centre is at the origin and radius 3.

Ex. 2. What are the conditions that the point (x, y) shall be outside, inside, or on a circle with centre at $(-3, 1)$ and radius 4?

Ex. 3. Draw a circle with centre at (a, b) and radius r , and write down the conditions that the point (x, y) shall be outside, inside, or on this circle.

17. Let the line AOB bisect the angle XOY .

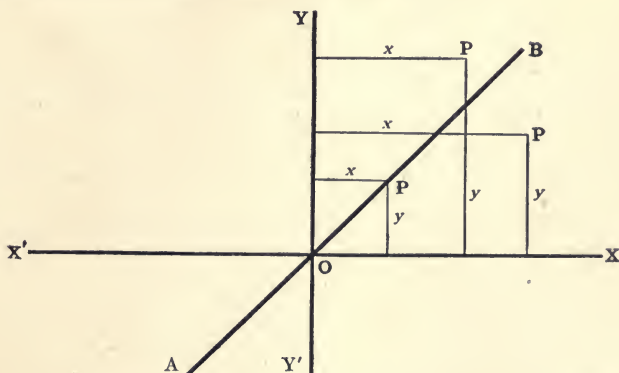

Then every point on AB is equidistant from the axes. Hence the point $P(x, y)$ is *above* AB , *below* AB , or *on* AB , according as

$$y > x, \quad y < x, \quad \text{or} \quad y = x,$$

or according as $y - x >, <, \text{ or } = 0;$

i.e. according as $y - x$ is positive, negative, or zero.

18. Draw CD parallel to AB , cutting the y -axis in E , three units above O .

Then every point on CD is three units farther from the x -axis than from the y -axis. Therefore the point $P(x, y)$ will be *above* CD , *below* CD , or *on* CD , according as

$$y >, <, \text{ or } = x + 3;$$

i.e. according as $y - x - 3$ is positive, negative, or zero.

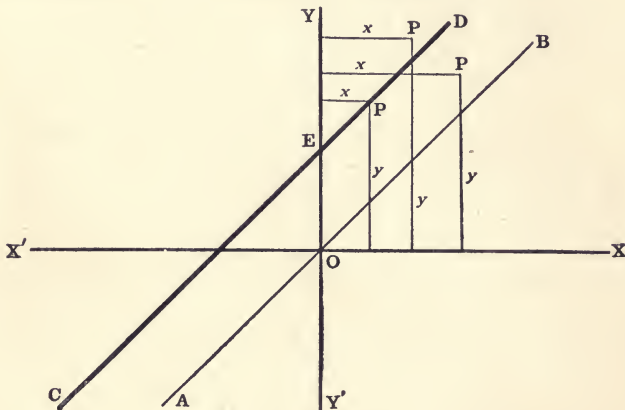

Ex. 1. Draw a line parallel to AB , cutting the y -axis two units below O ; and write down the conditions that the point (x, y) shall be above, below, or on this line.

Ex. 2. What are the conditions that the point (x, y) shall be above, below, or on the line through E parallel to the bisector of the angle $X'OY'$?

19. Let CD be the perpendicular bisector of the line joining $A(-1, 1)$ and $B(3, -1)$.

Then all points on CD are equidistant from A and B , and all other points are not equally distant from A and B . Hence the point $P(x, y)$ will lie to the *right* of, to the *left* of, or *on* CD , according as

$$AP >, <, \text{ or } = BP,$$

or according as

$$AP^2 >, <, \text{ or } = BP^2;$$

i.e. according as [(2), § 7]

$$(x + 1)^2 + (y - 1)^2 >, <, \text{ or } = (x - 3)^2 + (y + 1)^2;$$

whence

$$2x - y - 2 >, <, \text{ or } = 0.$$

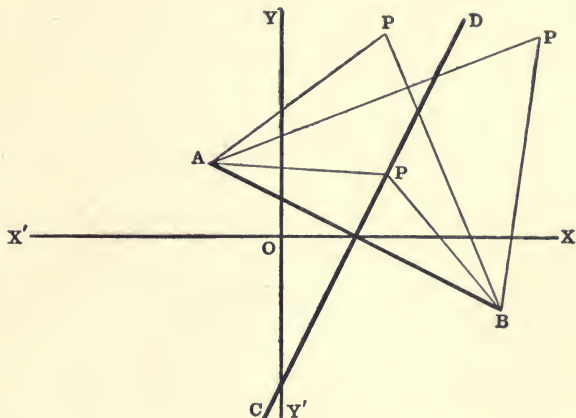

Ex. 1. Find the conditions that the point (x, y) shall be above, below, or on the perpendicular bisector of the line joining $(2, 3)$ and $(-1, -2)$.

Ex. 2. What is the condition that (x, y) shall be on the perpendicular bisector of the line joining (a, b) and (c, d) ?

where 20. The examples in §§ 14–19 illustrate certain general principles, of which we will here make only a preliminary statement.

I. All points whose coordinates satisfy an *equation of condition* (not an identity) lie on a certain line; and conversely, if a point lies on a fixed line, its coordinates must satisfy an *equation*.

II. Points whose coordinates satisfy a *condition of inequality* do not lie on any fixed line.

If $f(x, y)$ be used to represent any expression containing the two variables x and y and certain constants, these principles may be stated more definitely, as follows:

I. All points whose coordinates make $f(x, y) = 0$, lie on a certain line; and conversely, the coordinates of all points on this line make $f(x, y) = 0$.

II. If $f(x_1, y_1) > 0$ and $f(x_2, y_2) < 0$, the two points (x_1, y_1) and (x_2, y_2) lie on *opposite* sides of the line the coordinates of whose points make $f(x, y) = 0$.

Hence every line, as well as the axes of coordinates, is said to have a *positive* and a *negative* side.

DEF. The locus of a variable point subject to a given condition is the place, i.e. the totality of positions, where the point may lie and satisfy the given condition.

DEF. The line (or lines) containing all points, and no others, whose coordinates satisfy a given equation is called the **Locus of the Equation**; conversely, the equation satisfied by the coordinates of all points on a certain line (or lines) is called the **Equation of the Line**, or the **Equation of the Locus**.

DEF. That part of the plane containing all points, and no others, whose coordinates satisfy a given *inequation* is the *Locus of the Inequation*.

Thus the *Locus* of a point in Plane Geometry is *not always a line*.

In the examples of §§ 14–19 only Cartesian coordinates have been used, but the fundamental principles there illustrated, and also the above definitions, hold for all systems of coordinates.

Let the student give some similar illustrations with polar coordinates.

EXAMPLES

What is the locus of

1. $x^2 + y^2 = 0$? $x^2 + y^2 > 0$? $x^2 + y^2 < 0$?
2. $x = \sqrt{x^2 + y^2}$? $x > \sqrt{x^2 + y^2}$? $x < \sqrt{x^2 + y^2}$?
3. $\rho = a \sec \theta$? $\rho > a \sec \theta$? $\rho < a \sec \theta$?
4. $\rho = b \csc \theta$? $\rho > b \csc \theta$? $\rho < b \csc \theta$?
5. $4 < x^2 + y^2 < 9$?
6. $9 < (x-2)^2 + (y-3)^2 < 16$?
7. $a \sec \theta < \rho < b \sec \theta$?
8. $\rho = a \cos \theta$? $\rho > a \cos \theta$? $\rho < a \cos \theta$?
9. $a \cos \theta < \rho < b \cos \theta$?
10. $\rho = a \sin \theta$? $\rho > a \sin \theta$? $\rho < a \sin \theta$?
11. $\rho = a$? $\rho > a$? $\rho < a$?

12. What is the locus of a point moving so that the sum of its distances from the lines $x = 0$ and $x = 3$ is 1, 2, 3, 4?

TO FIND THE LOCUS OF A GIVEN EQUATION

21. If the locus of an equation is a straight line, the locus is easily drawn; it is only necessary to locate two points on it (preferably the intersections* with the axes) and draw a straight line through these points. Likewise, if the locus is a circle, the complete locus can be drawn when the centre and radius are known.

It will be shown farther on that straight lines and circles can easily be recognized by the forms of the equations.

In general, having given an equation of condition between the coordinates (in any system) of a variable point, we may assign any value we please to one coordinate and find a corresponding † value, or values, of the other. To every such pair of corresponding values will correspond a definite point of the locus. Since these pairs of values may be as numerous as we please, we can in this way locate as many points of the locus as we please. A smooth curve drawn through these points will be an *approximation* to the locus of the given equation. The degree of approximation will depend upon the proximity of the points thus located. This method of constructing a locus is applicable to any equation that can be solved for one of the variables, and is called **Plotting ‡ an Equation**, or **Plotting the Locus of an Equation**. The steps of this process are as follows:

* Unless *both* intersections are near the origin, when the line will be inaccurately determined, or both at the origin, when its direction will be quite undetermined.

† “Corresponding values” of the variables, x and y say, involved in a given equation are a pair of values of x and y which satisfy the equation.

‡ The logic of the process of plotting is that of induction, and should be so recognized by the student. Given the points A, B, C, D, E, F on a curve; then, in the absence of further knowledge, we take as a probable approximation a *smooth* curve drawn through them like the full curve in the figure. We are not war-

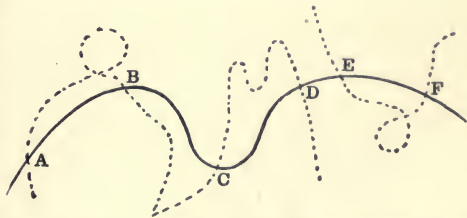

ranted in drawing such a curve as the dotted one through the points, because it is unlikely that, taking points at random on such an irregular curve, the position of these points should fail to disclose any of the irregularity. The student should also be warned that sudden changes of slope or curvature are as unlikely as sudden changes in the value of an ordinate.

- (1) Solve the equation with respect to *one* of the coordinates.
- (2) Assign to the *other* coordinate a series of values differing but little from each other.
- (3) Find each corresponding value, or values, of the *first* coordinate.
- (4) Locate the point corresponding to each pair of corresponding values thus found.
- (5) Join these points *in order* by a smooth curve, and this curve will be approximately the required locus. If there be doubt how to fill up any of the intervening spaces, interpolate more points.

22. ILLUSTRATIVE EXAMPLES.

Ex. 1. Plot the locus of the equation $10y = x^2 - 3x - 20$.

Assigning to x values from -8 to $+10$, differing by two units, we find the following pairs of values of x and y to satisfy the equation:

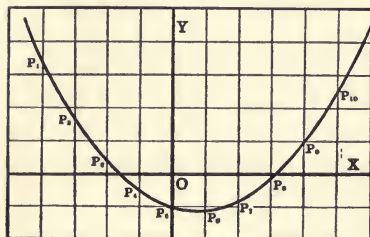

$x =$	-8	-6	-4	-2	0
$y =$	6.8	3.4	$.8$	-1	-2
$x =$	2	4	6	8	10
$y =$	-2.2	-1.6	$-.2$	2	5

Plotting the corresponding points P_1, P_2, P_3 , etc., and drawing a smooth curve through them in the order of the increasing values of x , we find the locus to be approximately the curve drawn in the figure.

Ex. 2. Plot the locus of the equation $y^2 = 4x$.

Solving for y gives $y = \pm 2\sqrt{x}$.

When $x = 0, 1, 4, 9, \dots$ to ∞ ,

$y = 0, \pm 2, \pm 4, \pm 6 \dots$ to $\pm \infty$,

The corresponding points of the locus are $O(0, 0), P_1(1, -2), P_2(1, 2), P_3(4, -4), P_4(4, 4), P_5(9, -6),$ and $P_6(9, 6) \dots$

When x is negative, y is imaginary. Therefore no points of the locus lie to the left of the y -axis. For every positive value of x there are two values of y numerically equal but opposite in sign. Hence the two corresponding points of the locus are equidistant from the x -axis. As x increases, both values of y increase numerically.

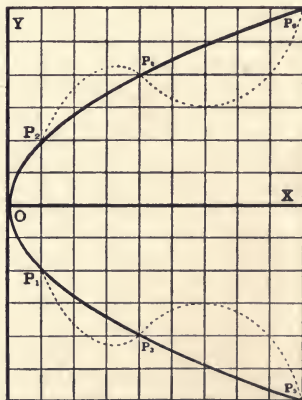

Therefore the locus cannot be such a curve as that represented by the dotted line, but must be approximately that indicated by the full line.

Ex. 3. Plot the locus of the equation $25(x-1)^2 + 16(y-3)^2 = 400$.

Solving for y gives $y = 3 \pm \frac{5}{4}\sqrt{16 - (x-1)^2}$.

This form of the equation shows that y is imaginary when $x < -3$, or $x > 5$, since $16 - (x-1)^2$ is then negative; and when x is neither less than -3 nor greater than 5 there are two real unequal values of y , one found by using the + sign before the radical, the other by using the - sign. Hence the locus lies between the two parallel lines $x = -3$ and $x = 5$.

The equation is satisfied by the following pairs of values of x and y :

$x =$	-3	-2	-1	0	
$y =$	3	6.3	7.3	7.8	
$y =$	3	- .3	-1.3	-1.8	
$x =$	-1	2	3	4	5
$y =$	8	7.8	7.3	6.3	3
$y =$	-2	-1.8	-1.3	- .3	3

The corresponding points are $P(-3, 3)$, $P_1(-2, 6.3)$, $P_2(-2, -.3)$, etc., and the locus is the curve shown in the figure.

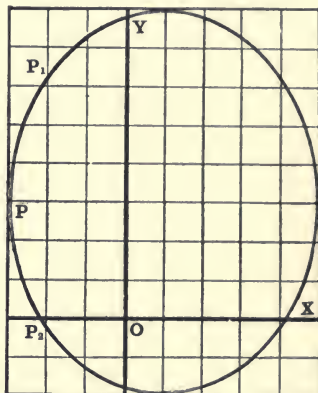

Ex. 4. Plot the locus of the equation, $\rho = 2a \sin \theta$.

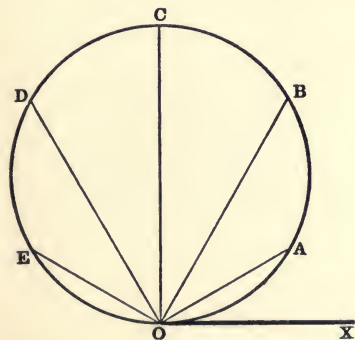

Here ρ has its greatest value when $\sin \theta$ has its greatest value, i.e. when $\theta = \frac{1}{2}\pi$. As θ increases from 0 to $\frac{1}{2}\pi$, $\sin \theta$ increases from 0 to 1, and ρ increases from 0 to $2a$; as θ increases from $\frac{1}{2}\pi$ to π , $\sin \theta$ decreases from 1 to 0, and ρ decreases from $2a$ to 0. Hence the locus starts from the origin and returns to the origin as θ is made to vary from 0 to π .

Assigning to θ values from 0 to 180° , differing by 30° we find the following points are on the locus:

$O(0, 0)$, $A(a, 30^\circ)$, $B(a\sqrt{3}, 60^\circ)$, $C(2a, 90^\circ)$, $D(a\sqrt{3}, 120^\circ)$, $E(a, 150^\circ)$, and $O(0, 180^\circ)$.

The complete locus is the curve shown in the figure.

Ex. a. Show that the points A, B, \dots all lie on a circle tangent to Ox at O and whose radius is a . Show also that every point on this circle satisfies the given equation.

Ex. *b*. Show that the same circle will be described as θ varies from 180° to 360° ; also as θ varies from any value α to $\alpha + \pi$.

We have in this example an illustration of a characteristic property of equations in polar coordinates containing a periodic function of θ . In such equations ρ takes all possible values as θ varies through a limited range of values called the period of the function. The complete locus is described at least once as θ varies through this period, and is repeated as θ varies through any other equal period.

The period of $\sin \theta$ is 2π ; hence ρ takes all possible values from $-2a$ to $+2a$ as θ varies from 0 to 2π . The whole circle is described twice as θ varies through this period, once as θ varies from 0 to π with ρ positive, and once as θ varies from π to 2π with ρ negative. Also the whole circle is described twice if θ starts from any value and varies through 2π in either direction.

Ex. 5. Plot the locus of the equation $\rho = \sin 2\theta$.

This equation is satisfied by the following pairs of values of ρ and θ :

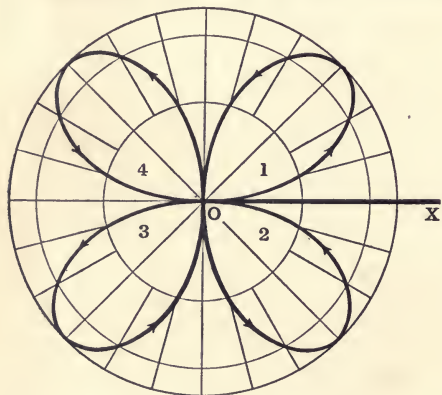

$$\theta = 45^\circ, 225^\circ, \rho = 1.$$

$$\theta = 135^\circ, 315^\circ, \rho = -1.$$

$$\theta = 30^\circ, 60^\circ, 210^\circ, 240^\circ, \\ \rho = \frac{1}{2}\sqrt{3}.$$

$$\theta = 120^\circ, 150^\circ, 300^\circ, 330^\circ, \\ \rho = -\frac{1}{2}\sqrt{3}.$$

$$\theta = 15^\circ, 75^\circ, 195^\circ, 255^\circ, \\ \rho = \frac{1}{2}.$$

$$\theta = 105^\circ, 165^\circ, 285^\circ, 345^\circ, \\ \rho = -\frac{1}{2}.$$

$$\theta = 0^\circ, 90^\circ, 180^\circ, 270^\circ, 360^\circ, \\ \rho = 0.$$

The corresponding points are found by drawing three circles with centres at O and radii $\frac{1}{2}$, $\frac{1}{2}\sqrt{3}$, and 1, and then drawing radii dividing these circles into arcs of 15° . The locus is the four-leaf curve shown in the figure.

As θ varies from 0 to 2π , the four leaves are described in the order 1, 2, 3, 4, and in the direction indicated by the arrow heads.

EXAMPLES

Plot the loci of the following equations :*

$$1. \left\{ \begin{array}{l} 2x - 3y - 6 = 0. \\ 4x - 6y - 6 = 0. \\ 6x - 9y + 27 = 0. \end{array} \right\} \dagger$$

$$2. \left\{ \begin{array}{l} 2x + 3y + 5 = 0. \\ 3x - 2y - 12 = 0. \\ 5x + 2y - 4 = 0. \end{array} \right\}$$

* For convenience in plotting loci the student should be supplied with "coordinate paper," both "rectangular" and "polar."

† Loci grouped under the same number should be plotted on the same diagram.

$$\checkmark 3. \begin{cases} 2x + 9y + 13 = 0. \\ y = 7x - 3. \\ 2y - x = 2. \end{cases}$$

$$7. 6x^2 + 5xy - 6y^2 = 0.$$

$$\checkmark 8. \begin{cases} x^2 + y^2 = 4. \\ x^2 - y^2 = 4. \end{cases} \quad 9. \begin{cases} xy = 2. \\ xy = -2. \end{cases}$$

$$11. \begin{cases} 4(x+1) = (y-2)^2. \\ 10y = (x+1)^2. \end{cases}$$

$$\checkmark 13. \begin{cases} y = (x^2 - 4)^2. \\ y^2 = (x^2 - 4)^2. \end{cases}$$

$$16. y = x, x^2, x^3, x^4, x^5, \dots x^n. \quad x = y, y^2, y^3, y^4, y^5, \dots y^n.$$

$$4. (x-4)(y+3) = 0.$$

$$5. (x^2 - 4)(y - 2) = 0.$$

$$6. x^2 - y^2 = 0. \quad 4x^2 - y^2 = 0.$$

$$10. \begin{cases} x^2 + y^2 = 25. \\ (x-8)^2 + (y-4)^2 = 25. \\ (x-4)^2 + (y-2)^2 = 5. \end{cases}$$

$$12. y = x^3 - 4x^2 - 4x + 16.$$

$$14. \begin{cases} y = x^4 - 20x^2 + 64. \\ y^2 = x^4 - 20x^2 + 64. \end{cases}$$

$$15. (x^2 + y^2)^2 = a^2(x^2 - y^2).$$

Note the effect of interchanging x and y ; e.g. the locus of $x = y^3$ is obtained from the locus of $y = x^3$ by revolving the plane through 180° around the line $y = x$.

$$17. y = (x-1), (x-1)^2, (x-1)^3. \quad \times 18. y = x^3, x^3 - x, x^3 + x. \quad \text{!}$$

$$\checkmark 19. y^2 = x, x^2, x^3, x^4.$$

$$20. y = \sin x, \cos x, \sin^{-1} x, \cos^{-1} x.$$

$$21. y = \tan x, \cot x, \tan^{-1} x, \cot^{-1} x.$$

$$22. y = \sec x, \csc x, \sec^{-1} x, \csc^{-1} x.$$

$$+ \checkmark 23. y = \sin 2x, \sin \frac{x}{2}, \frac{1}{2} \sin 2x, 2 \sin \frac{x}{2}. \quad 24. y = b \sin \frac{x}{a}, b \sin \frac{x+c}{a}.$$

$$25. \rho = \sin \theta, \cos \theta, \sec \theta, \csc \theta.$$

$$\times 26. \rho = \sin 3\theta, \sin 4\theta.$$

$$27. \rho = \cos 2\theta, \cos 3\theta, \cos 4\theta.$$

$$28. \rho = \tan \theta, \cot \theta.$$

$$\checkmark 29. \rho = \sin \frac{1}{2}\theta, \cos \frac{1}{2}\theta.$$

$$30. \rho = \frac{2}{1 - \cos \theta}, \frac{6}{3 - 2 \cos \theta}.$$

$$\checkmark 31. \rho = a \cos \theta + b.$$

$$32. \rho^2 = \sec 2\theta, \csc 2\theta. \quad (\text{Cf. No. 9.})$$

$$\checkmark 33. y = 2^x, \log_2 x.$$

$$34. y = 10^x, \log_{10} x.$$

$$\checkmark 35. y = a^x, \log_a x. \quad (a >, =, < 1.) \quad \times 36. y = 2^x, 2^{-x}, \frac{1}{2}(2^x + 2^{-x}).$$

$$37. y = e^{\frac{x}{a}}, e^{-\frac{x}{a}}, \frac{1}{2}(e^{\frac{x}{a}} + e^{-\frac{x}{a}}). \quad \text{Catenary, if } e = 2.7 +.$$

$$38. y = \frac{x-2}{x-3}, \frac{(x-1)(x-2)}{x-3}.$$

$$39. y = \frac{(x-1)(x-2)}{(x-3)(x-4)}, \frac{(x-1)(x-3)}{(x-2)(x-4)}.$$

$$+ 40. y = \frac{x+2}{x+3}, \frac{(x-1)(x-3)}{x-2}.$$

$$41. y = \frac{(x+1)(x-2)}{(x+3)(x-4)}, \frac{(x+2)(x-4)}{(x-1)(x-3)}.$$

$$42. y = \frac{(x-1)(x-3)(x-5)}{(x-2)(x-4)(x-6)}.$$

$$43. y = \frac{(x+1)(x-4)(x-6)}{(x-1)(x+2)(x-3)}.$$

$$44. y = \frac{(x-1)(x-3)(x-5)}{(x-2)(x-4)}.$$

$$45. y = \frac{(x-1)(x+3)(x-5)}{(x-2)(x-4)}.$$

$$46. y = \frac{x^2 + 1}{x^2}.$$

$$47. y = \frac{x^3 + x^2 + 1}{x^2}.$$

$$48. y = \frac{x^2 + 2}{(x + 2)^2}.$$

$$49. y = \frac{x^3 + 1}{(x - 1)^2}.$$

$$50. y = \frac{(x - 1)(x - 3)}{(x - 2)^2}.$$

$$51. y = \frac{x^2 + 1}{(x - 2)(x - 3)}.$$

52. Are the points $(3, 60^\circ)$ $(\frac{3}{2}, -90^\circ)$ on the same or opposite sides of the loci of Ex. 30?

53. Which of the following loci pass through the origin?

$$\dagger (1) 2x + 3y = 0. \quad \dagger (4) y^2 - a^2x^2 = 0. \quad \dagger (7) y^2 = 4ax.$$

$$\dagger (2) x^2 + y^2 = 1. \quad (5) ax + by + c = 0. \quad (8) y^2 = 4a(x + a).$$

$$\dagger (3) y = 3x^2 - x. \quad (6) ax^2 + by^2 = 1. \quad (9) (x - a)^2 + (y - b)^2 = a^2 + b^2.$$

What is the necessary and sufficient condition that the locus of an equation in Cartesian coordinates shall pass through the origin?

THE USE OF GRAPHIC METHODS

23. It has been shown in §§ 14-20 that whenever the relation between two quantities, whose values depend upon one another, can be definitely expressed by an equation, then the geometric or *graphic* representation of this relation is given by means of a curve. Such a curve often gives at a glance information which otherwise could be obtained only by considerable computation; and in many cases reveals facts of peculiar interest and importance which might otherwise escape notice.

The use of graphic methods in the study of physics, analytical mechanics, engineering, and many other branches of scientific investigation, is already extensive and is rapidly increasing. Graphic methods can be used, however, not only in examples where the equation connecting the two variable quantities is known, such as those already given, but also in examples where no such relation can be found; in these latter cases the graphic method furnishes almost the only practical means of studying the relations involved.

Comparative statistics, and results of experiments and direct observations, can frequently be more concisely and forcibly represented graphically than by tabulating numerical values. The following are simple examples of this kind:

1. The following table shows the net gold (to the nearest million of dollars) in the U. S. Treasury at intervals of one month, from Jan. 10, 1893, to Oct. 31, 1894 (Report of the Sec. of the Treas., 1894, p. 8):

1893	Millions of Dollars.	1893	Millions of Dollars.	1894	Millions of Dollars.	1894	Millions of Dollars.
Jan. 10	120	July 10	97	Jan. 10	74	July 10	65
Feb. 10	112	Aug. 10	104	Feb. 10	104	Aug. 10	52½
Mar. 10	102	Sept. 9	98	Mar. 10	107	Sept. 10	56
Apr. 10	106	Oct. 10	87	Apr. 10	106	Oct. 10	60
May 10	99	Nov. 10	85	May 10	92	Oct. 31	61
June 10	91	Dec. 9	84	June 9	69

Using time (in months) as abscissas, and dollars (1,000,000 per unit) as ordinates, the separate points represented by the table have been plotted (Fig. 1) and then joined by a smooth curve.

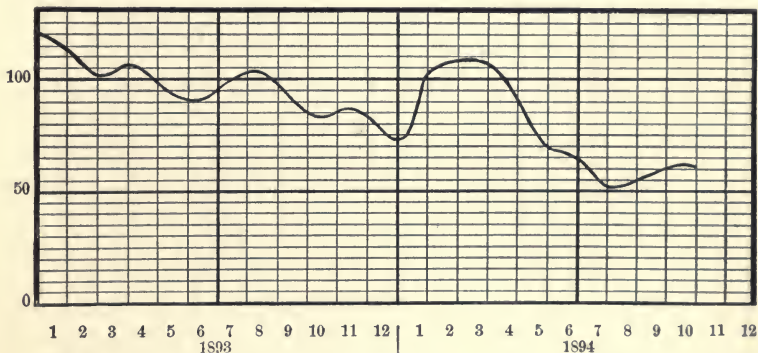

FIG. 1.

In this example the curve gives no *new* information, but it presents in a much more concise form the information given by the tabulated numbers. Observe also that *if the points are inaccurately located, the diagram becomes not only worthless, but misleading.*

2. An excellent example of the use and advantages of the graphic method of representing comparative statistics is found in the large engraved plate placed under the front cover of the Annual Report of the Secretary of the Treasury for 1894. This plate presents on a single sheet information that covers several pages when expressed in tabulated numbers. All of the curves given on this plate, except one, are shown (on a smaller scale) in Fig. 2. This figure should be carefully studied, and if possible the original plate should be consulted.

3. The curves in figures 1 and 2 were constructed by locating separate points and then drawing a smooth curve through these points. Such curves give no *new* information, but represent graphically information already ascertained.

In some cases, however, curves can be drawn mechanically. When this is possible the curve is constructed, not for the purpose of exhibiting facts previously known, but for the purpose of *obtaining new information.* For instance, in the stations of the U. S. Weather Bureau an instrument called

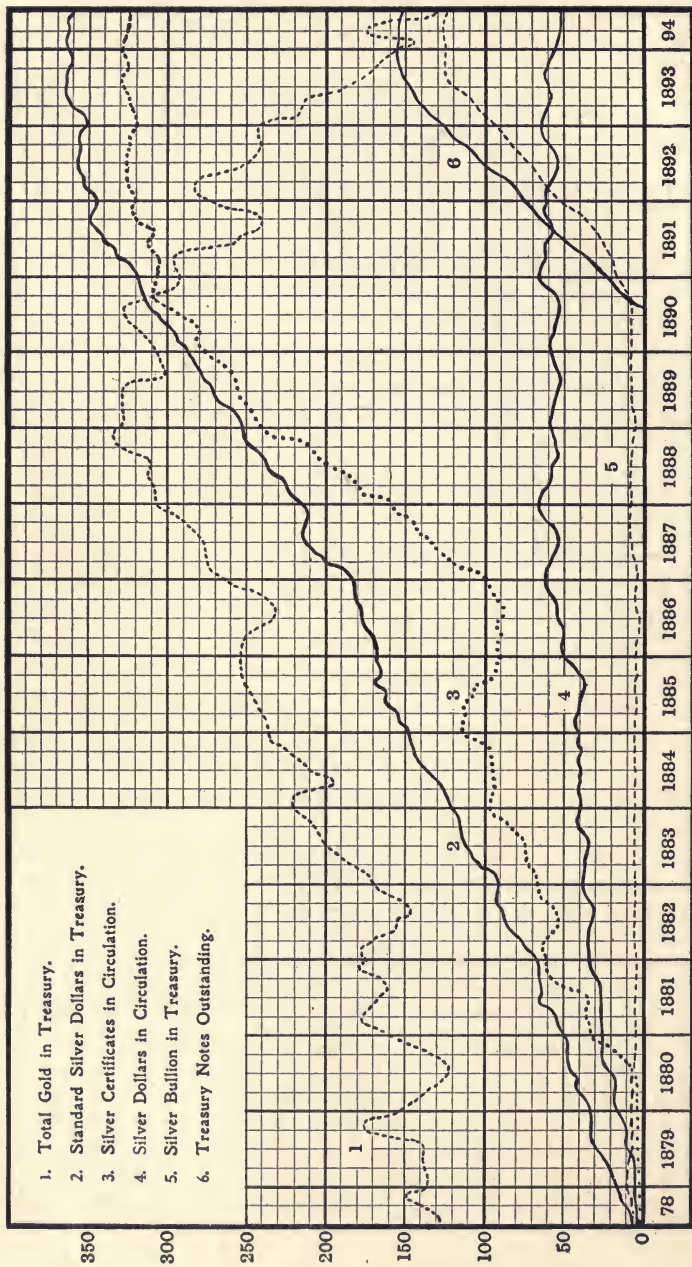

Fig. 2.— Gold and Silver in the Treasury of the United States, and Circulation of Silver and Silver Certificates, at the end of each quarter, in millions of dollars. (Report of the Secretary of the Treasury, 1894. Plate under front cover.)

the Thermograph* constructs automatically a curve which shows the continuous variation of the local temperature. Similarly the Barograph* records the variation of the barometric pressure, etc.

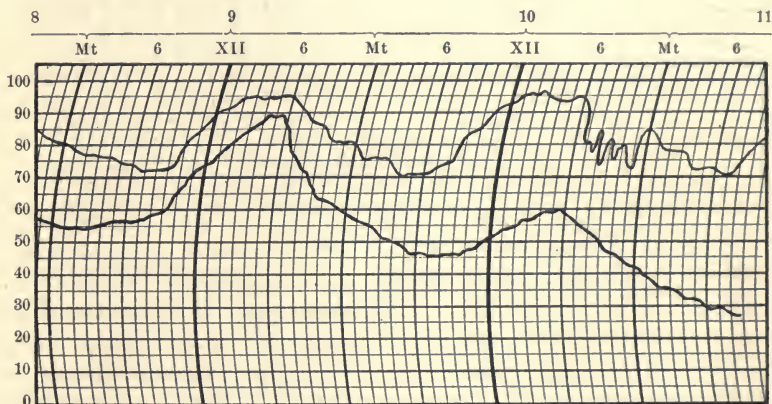

FIG. 3.— Thermographs for Aug. 9-10 and Sept. 27-28, 1899, at Lincoln, Neb.

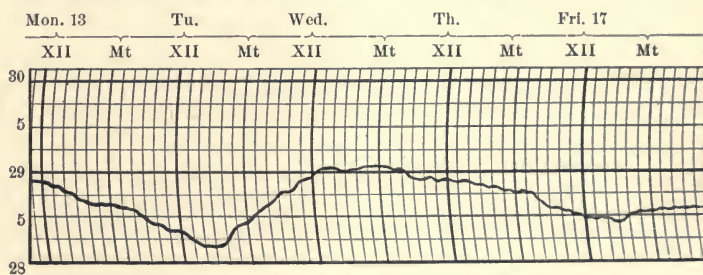

FIG. 4.— Barograph Sheet, March 13-17, 1899, at Lincoln, Neb.

Figures 3 and 4 are copies of curves thus constructed in the local station at Lincoln, Neb. The upper curve in Fig. 3 shows the temperature from 10 P.M. Aug. 8, 1899, to 9 A.M. Aug. 11, 1899; the lower from 11 P.M. Sept. 26, 1899, to 8 A.M. Sept. 29, 1899. Interpret these curves. Notice especially the record from 6 P.M. to midnight Aug. 10.

The varying pressure on the piston in the cylinder of a steam engine is determined in the same way by means of a similar instrument, called an Indicator.*

4. Exhibit graphically the information contained in the following table of wind velocities for Jan. 20 and June 15 and 25, 1894:

* For a description and cut of the "Thermograph," "Barograph," and "Indicator," see these words in the Century, Standard, or Webster's International Dictionary.

Day	12-1	1-2	2-3	3-4	4-5	5-6	6-7	7-8	8-9	9-10	10-11	11-12
Jan. 20, A.M. . .	3	6	7	7	8	9	12	15	15	19	12	21
June 15, A.M. . .	15	11	8	10	8	9	8	8	11	15	17	21
June 25, A.M. . .	17	14	13	13	11	23	23	13	9	4	2	10
Jan. 20, P.M. . .	22	22	18	19	14	9	6	7	5	6	5	4
June 15, P.M. . .	15	21	22	20	17	17	12	5	5	6	6	3
June 25, P.M. . .	12	15	11	12	12	5	1	3	6	7	7	3

INTERSECTION OF LOCI

24. To find the points of intersection of two loci when their equations are known.

Since the points of intersection of two loci lie on both curves, their coordinates must satisfy both equations. Therefore, to find the coordinates of the points of intersection of two loci we treat their equations simultaneously, regarding the coordinates as the unknown quantities, and thus find the values of the coordinates which satisfy both equations. A pair of values which satisfy both equations are the coordinates of a point of intersection of the two loci.

If the equations are both of the first degree, there will be but one pair of values of coordinates satisfying them, and therefore but one point of intersection of the loci.

If one or both of the equations be of a higher degree than the first, there will be several pairs of roots, and *one* point of intersection for *each pair*. The loci will then have several points of intersection.

If of a pair of roots *even one* is imaginary, there is no corresponding real point common to the two loci. We then say the intersection is imaginary.

Since imaginary roots of equations always occur in pairs, imaginary intersections of loci always occur in pairs, and hence the passage from a real pair of intersections to an imaginary one is through a coincident pair. Suppose, for example, that a straight line intersects a circle in two real points. If the line be moved so that it becomes tangent to the circle, the two points of intersection coincide in the point of contact. If the line be moved still farther, the intersections are said to become imaginary.

25. *Intercepts on the axes of coordinates.*

This is a special and very important case of the preceding section in which one of the given equations is $x = 0$, or $y = 0$.

To find the points of intersection of a curve with the x -axis, put $y = 0$ in the equation of the curve and solve the resulting equation for x . The roots of this equation in x represent the distances from the origin to the points of intersection; and these distances are called the **x -intercepts** of the given curve.

Similarly, to find the **y -intercepts**, put $x = 0$ in the given equation and solve the resulting equation for y .

Ex. 1. How many x -intercepts may a curve of the n th degree have? *$n - x$ intercepts*

Ex. 2. What does it mean when in an equation in polar coordinates we put $\theta = 0$? $\rho = 0$?

26. A line may be defined as the path of the moving point. Then, if (x, y) be the moving point, both x and y are *variable* quantities, and are called the **variable** or **current coordinates** of the moving point. The path of the moving point is then determined by the condition that its coordinates must vary only in such a manner as always to satisfy a given equation; *i.e.* although *both coordinates vary the relation between them remains fixed*.

EXAMPLES

Find the intercepts and the points of intersection of the following loci :

1. $2x + 3y = 12$, $4x - y = 5$. 7. $x - 3y = 0$, $x^2 + y^2 + 20y = 0$.
2. $3x + 5y = 1$, $x - 3y + 7 = 0$. 8. $y^2 = 4ax$, $2xy = a^2$.
3. $5x - 2y + 4 = 0$, $x - 2y = 4$. 9. $y^2 = 4ax$, $y^2 - x^2 = a^2$.
4. $x + 3y = 15$, $x^2 + y^2 = 25$. 10. $y^2 = 4ax$, $x^2 = 4ay$.
5. $3x - 4y = 20$, $x^2 + y^2 - 10x - 10y + 25 = 0$.
6. $5x + 4y = 20$, $x^2 + y^2 = 4$.

11. Find the points of intersection of the loci of Nos. 1, 2, 3, 9, 15, 17, 18, 19, 20, 21, 26 in the last preceding set of examples.

12. Find the intercepts of the loci of Nos. 7, 9, 10, 11, 12, 13, 14, 18, 19, 20 of the same set and check the results by the plots already made.

13. Find the area of the triangle whose sides are $x - 3y + 5 = 0$, $3x + 4y = 11$, $x^2 + 7y = 3$.

SYMMETRY OF LOCI

27. The process of constructing a locus explained in § 21 is long and tedious. It may often be shortened by an examination of the peculiarities of the given equation, such as the limiting values of the variables for which both are real (see Ex. 3, § 22), symmetry, etc. Such considerations will often reveal the general form and limits of the curve and give all the information desired with little labor. The intercepts (§ 25) are almost always useful for this purpose.

DEFINITIONS. Two points A and B are said to be *symmetrical with respect to a centre O* when the line AB is bisected by O .

Two points C and D are said to be *symmetrical with respect to an axis* when the line CD is bisected at right angles by the axis.

The two points (x, y) and $(-x, -y)$ are symmetrical with respect to the origin; (x, y) and $(x, -y)$ with respect to the x -axis.

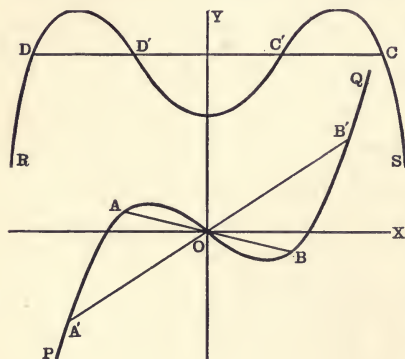

A curve is said to be *symmetrical with respect to a centre O* when all lines passing through O meet the curve in a pair, or pairs, of points symmetrical with respect to O .

A curve is said to be *symmetrical with respect to an axis* when all lines perpendicular to the axis meet the curve in a pair, or pairs, of points symmetrical with respect to the axis.

Or, in other words, a curve is symmetrical with respect to an axis, if the figure appears the same when a plane mirror is placed on the axis perpendicular to the plane of the curve.

The curve PQ is symmetrical with respect to the origin, and RS is symmetrical with respect to the y -axis.

The principal kinds of symmetry arising from the form of the equation are as follows:

28. *Equations in Cartesian Coordinates.*

(1) If $f(x, y) \equiv f(x, -y)$,* the locus of the equation $f(x, y) = 0$ is symmetrical with respect to the x -axis; i.e.

If an equation is not altered when the sign of y is changed, its locus is symmetrical with respect to the x -axis.

Let (x', y') be any point on the locus $f(x, y) = 0$.

Then, since $f(x, y) \equiv f(x, -y)$, by hypothesis,

$$f(x', y') = f(x', -y') = 0.$$

That is, the point $(x', -y')$ is also on the locus. Therefore, since the line $x = x'$ meets the locus in any point (x', y') , it will also meet the locus in the symmetrical point $(x', -y')$, and the curve is symmetrical with respect to the x -axis.

Ex. Let $f(x, y) = y^2 - 4x$, then $f(x, -y) = (-y)^2 - 4x = y^2 - 4x$.

Therefore $f(x, y) \equiv f(x, -y)$ and the curve $y^2 - 4x = 0$ is symmetrical with respect to the x -axis. (See Ex. 2, § 22.)

(2) Similarly, if $f(x, y) \equiv f(-x, y)$, the locus of $f(x, y) = 0$ is symmetrical with respect to the y -axis.

Ex. $y - \cos x \equiv y - \cos(-x)$.

Therefore the locus of $y = \cos x$ is symmetrical with respect to the y -axis.

(3) If $f(x, y) \equiv \pm f(-x, -y)$, the locus of $f(x, y) = 0$ is symmetrical with respect to the origin.

Let (x', y') be any point on the locus $f(x, y) = 0$.

Then, since $f(x, y) \equiv \pm f(-x, -y)$ by hypothesis,

$$f(x', y') = f(-x', -y') = 0.$$

Hence the straight line through the origin and the point (x', y') meets the locus again in the symmetrical point $(-x', -y')$. Therefore the curve is symmetrical with respect to the origin.

Ex.
$$\begin{aligned} \frac{x^2}{a^2} + \frac{y^2}{b^2} - 1 &\equiv \frac{x^2}{a^2} + \frac{(-y)^2}{b^2} - 1 \equiv \frac{(-x)^2}{a^2} + \frac{y^2}{b^2} - 1 \\ &\equiv \frac{(-x)^2}{a^2} + \frac{(-y)^2}{b^2} - 1. \end{aligned}$$

* The sign " \equiv " means "identical with," i.e. the same for all values of x and y , and therefore that the two expressions vanish for the same values of x and y .

E.g. $(x + y)^2 \equiv x^2 + 2xy + y^2$, $\cos x \equiv \cos(-x)$.

Therefore the curve $\frac{x^2}{a^2} + \frac{y^2}{b^2} = 1$ is symmetrical with respect to both axes and the origin. (See figure, § 34.)

(4) If $f(x, y) \equiv f(y, x)$ the locus of $f(x, y) = 0$ is symmetrical with respect to the line $y = x$. E.g. $x^2 + y^2 = 1$.

(5) If $f(x, y) \equiv f(-y, -x)$ the locus of $f(x, y) = 0$ is symmetrical with respect to the line $y = -x$. E.g. $xy = \pm 1$.

Let the student prove propositions (4) and (5).

The foregoing conditions of symmetry are both *necessary* and *sufficient*; i.e. if either one of the conditions (3), for example, is satisfied, the locus is symmetrical with respect to the origin, otherwise not. The student, however, should examine the opposite propositions independently.

The following conditions, (6), (7), (8), are *sufficient*, but not *necessary*; i.e. the opposite propositions are not necessarily true.

(6) If an equation contains only even powers of y , its locus is symmetrical with respect to the x -axis. [From (1).]

(7) If an equation contains only even powers of x , its locus is symmetrical with respect to the y -axis. [From (2).]

(8) If an equation contains only even powers of both x and y , its locus is symmetrical with respect to both axes and also with respect to the origin. [From (3).]

In an algebraic* equation either one of the following conditions is *sufficient*, and one or the other is *necessary*.

(9) If all the terms of an algebraic equation are of even degree, or if all the terms are of odd degree, its locus is symmetrical with respect to the origin. [From (3).]

Show that (6), (7), (8), and (9) follow from (1), (2), and (3).

Show that (6), (7), (8) are *necessary* conditions of symmetry if the equation is algebraic.

* A function in which the variables are involved in no other way than by addition, subtraction, multiplication, division, and root extraction is called an *Algebraic Function*. All others are called *Transcendental Functions*.

$$\text{E.g. } 3x^2 - 2x + 4, x^2 - axy + by^2, \frac{ax^3 + by^2}{x+a} + n\sqrt{xy},$$

are algebraic functions; while ax , $\sin x$, $\sec^{-1} y$, $\log(x^2 + y)$ are transcendental functions.

29. Equations in Polar Coordinates.

The best way to determine the symmetric properties of loci in polar coordinates is to transform their equations to rectangular coordinates, and then apply the tests given in § 28.

The following conditions, however, are useful in simple cases. They are *sufficient* but not *necessary*, conditions of symmetry.

(1) If $f(\theta) \equiv f(-\theta)$, or, if $f(\theta) \equiv -f(\pi - \theta)$, the locus of $\rho = f(\theta)$ is symmetrical with respect to OX .

(2) Similarly, if $f(\theta) \equiv f(\pi - \theta)$, or, if $f(\theta) \equiv -f(-\theta)$, the locus of $\rho = f(\theta)$ is symmetrical with respect to OY .

(3) If $f(\theta) \equiv f(\pi + \theta)$, the locus of $\rho = f(\theta)$ is symmetrical with respect to O .

EXAMPLES

In what respects are the loci of the following equations symmetrical?

- | | | | |
|--|---------------------------------------|---|---------------------------------|
| 1. $y = x^2$. <i>to y-axis</i> | 2. $y = x^4$. | 3. $y^2 = x$. | 4. $y^4 = x$. <i>to x-axis</i> |
| 5. $y = x^3$. | 6. $x^3 = y$. <i>to origin</i> | 7. $y^2 = x^3$. | 8. $y^3 = x^2$. |
| 9. $y^2 = x^2$. | 10. $y = x^5$. " | 11. $y^2 = x^4$. | 12. $y^4 = x^2$. |
| 13. $y^2 = x^6$. | 14. $y^6 = x^2$. " | 15. $y^4 = x^6$. | 16. $y^3 = x^4$. |
| 17. $y = x^3 - x$. <i>to origin</i> | 18. $y = x^3 - x^2$. | 19. $y = x^4 - x^2$. | 20. $y = x^4 - x^3$. |
| 21. $xy = a$. | 22. $x^2y = a$. | 23. $ax^2 + by^2 = 1$. <i>to origin</i> | |
| 24. $ax^2 + 2bxy + cy^2 = 1$. | | 25. $ax^2 + 2bxy + ay^2 = 1$. | |
| 26. $xy - 2(x + y) = 1$. | | 27. $x^3 + y^3 = 1$. <i>to origin</i> | |
| 28. $x^4 + y^4 = 1$. <i>to origin</i> | | 29. $x^4 = y^2(4a^2 - x^2)$. | |
| 30. $x(y + x)^2 + a^2y = 0$. | | 31. $x^2y^2 = a^2(x^2 + y^2)$. | |
| 32. $x^{\frac{1}{2}} + y^{\frac{1}{2}} = a^{\frac{1}{2}}$. <i>to origin</i> | | 33. $x^{\frac{2}{3}} + y^{\frac{2}{3}} = a^{\frac{2}{3}}$. | |
| 34. $(a - x)y^2 = (a + x)x^2$. | | 35. $(a - x)y^2 + x^3 = 0$. | |
| 36. $y = \frac{1}{2}(2^x + 2^{-x})$. | 37. $y = \frac{1}{2}(2^x - 2^{-x})$. | 38. $\rho^2 = \cos 2\theta$. | 39. $\rho^2 = \sin 2\theta$. |

40. Point out the symmetric properties of the loci in the last two preceding sets of examples, especially those given in polar coordinates.

41. Show that if an equation is not altered when $-x$ is written in the place of y , and y in the place of x , its locus will show no change in position when the curve is turned about the origin through a right angle in its plane. For an example see No. 7, p. 27; also $2x^2 - 3xy - 2y^2 = c$.

The locus of $x^4 + a^2xy - y^4 = 0$ is also such a curve.

TO FIND THE EQUATION OF A LOCUS, HAVING GIVEN ITS GEOMETRIC DEFINITION

30. It should be borne in mind that to find the equation of a locus we have merely to find an equation that is satisfied by the coordinates of every point on the locus, and not satisfied by the coordinates of any other point. It is not easy to give specific directions which can be applied in all cases, but the following plan will be useful to the beginner, at least in the simpler cases :

(1) Choose the system of coordinates best adapted to the locus under consideration, and select a convenient set of axes.

(2) Write down the *geometric equation* which expresses the given geometric definition, or any known geometric property of the locus.

(3) Express this geometric equation in terms of the chosen system of coordinates, and simplify the result.

The following examples will give a better idea of the method of procedure than any formal rules ; they should be carefully studied :

31. To find the equation of any straight line.

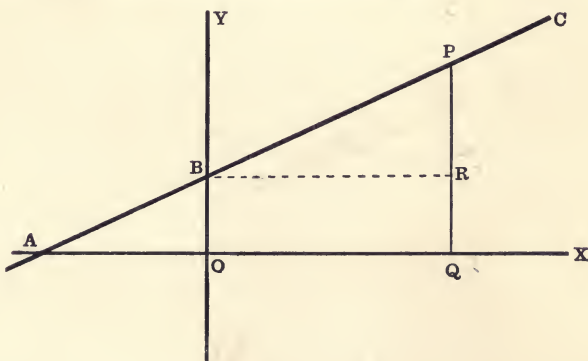

Let ABC be any straight line meeting the axes in A and B .

Let $OB = b$, let $\tan XAC = m$.

Let $P(x, y)$ be any point on the line.

Draw PQ parallel to OY , and BR parallel to OX .

Then for the geometric equation we have

$$QP = QR + RP = OB + BR \tan PBR.$$

$$\text{But } QP = y, \quad OB = b, \quad BR = x, \quad \tan PBR = m.$$

$$\therefore y = mx + b, \tag{1}$$

which is the required equation.

For any particular straight line the quantities m and b remain the same, and are therefore called constants. Of these, m , the tangent of the angle between the line and the x -axis, is called the **Slope** of the line, while b is the y -intercept.

By giving suitable values to the constants m and b , (1) may be made to represent any straight line whatever, *e.g.*

If $b = 0$, we have

$$y = mx, \tag{2}$$

for the equation of *any* line through the origin.

Quantities entering into an equation, such as m and b , which remain constant so long as we consider any particular curve, but whose variation causes a change in the position, size, or shape of the curve, are called **Parameters** of the curve.*

Moreover, any equation that can be put in the form (1), *i.e.* y equals some multiple of x plus a constant, represents a straight line.

The general equation of the first degree

$$Ax + By + C = 0 \tag{3}$$

may be written
$$y = -\frac{A}{B}x - \frac{C}{B},$$

and therefore (3) represents a straight line whose slope is $-\frac{A}{B}$ and whose y -intercept is $-\frac{C}{B}$. (See § 43.)

Ex. 1. If b varies in (1) while m remains constant, how will the line change position? If m varies while b remains constant? If m varies in (2)?

Ex. 2. What will be true of the signs of m and b when the line crosses the various quadrants?

* The difference between *parameters* and *coordinates* should be carefully noted; also the difference in the effect of a variation of the parameters of an equation and the variation of the current coordinates. (See § 26.)

32. To find the equation of a circle referred to any rectangular axes.

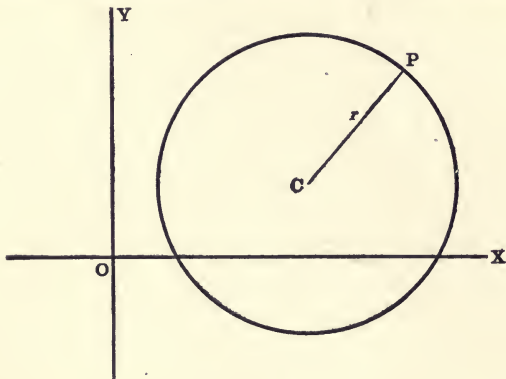

Let $r =$ radius, and let $C(a, b)$ be the centre.

Let $P(x, y)$ be any point on the circle.

Then $CP = r.$ [Geometric equation.]

But $CP^2 = (x - a)^2 + (y - b)^2.$ [(2), § 7.]

$$\therefore (x - a)^2 + (y - b)^2 = r^2 \quad (1)$$

is the required equation.

If $a = r$ and $b = 0$, (1) reduces to

$$x^2 + y^2 - 2rx = 0. \quad (2)$$

If $a = -r$ and $b = 0$, (1) becomes

$$x^2 + y^2 + 2rx = 0. \quad (3)$$

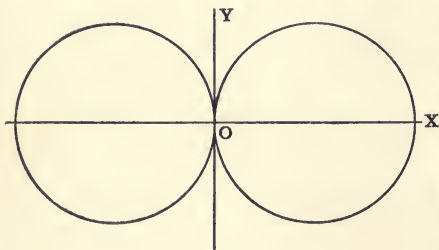

The circle at the right in the figure is the locus of equation (2); the circle at the left is the locus of equation (3).

When the centre is at the origin, $a = b = 0$, and we have for the simplest equation of the circle in

Cartesian coordinates the standard form (§ 16),

$$x^2 + y^2 = r^2. \quad (4)$$

Moreover, any equation of the second degree in which the term in xy is wanting and the coefficients of x^2 and y^2 are equal, can be written in the form of equation (1), and therefore will represent a circle, real or imaginary. For example, the equation

$$x^2 + y^2 - 4x + 6y - 3 = 0$$

may be written in the form

$$(x-2)^2 + (y+3)^2 = 16,$$

which shows that its locus is a circle whose centre is at the point $(2, -3)$, and whose radius is 4.

EXAMPLES

1. What is the form of the equation and the position of the circle, if $b = \pm r$ and $a = 0$?

2. What are the parameters in these equations? Discuss the effect produced by their variation.

Find the centres and radii of the following circles:

3. $x^2 + y^2 \pm 4x = 0.$

4. $x^2 + y^2 \pm 6y = 0.$

5. $x^2 + y^2 + 2x - 4y = 0.$

6. $x^2 + y^2 - 3x + 5y = 0.$

7. $x^2 + y^2 + 6x - 4y + 9 = 0.$

8. $4(x^2 + y^2) - 12x + 8y - 23 = 0.$

9. $x^2 + y^2 + 3x + 8y - 11 = 0.$

10. $4(x^2 + y^2) - 20x - 32y + 25 = 0.$

11. Find the general equation of a circle which touches both axes.

33. Polar equations of the circle.

It follows from (1), § 8, that the polar equation of the circle whose centre is at the point (a, a) and whose radius is r , is

$$\rho^2 - 2a\rho \cos(\theta - a) + a^2 - r^2 = 0. \quad (1)$$

If the pole is on the circle, the equation is

$$\rho = 2r \cos(\theta - a); \quad (2)$$

if the centre is also on the initial line, the equation is

$$\rho = 2r \cos \theta; \quad (3)$$

if the circle is above the initial and tangent to it at the pole, its equation is

$$\rho = 2r \sin \theta. \quad (4)$$

Ex. 1. Why is (1) of the second degree in ρ while (2), (3), and (4) are of the first degree? When is the pole outside, and when inside the circle? Discuss the effect of the variation of the parameters in these polar equations.

Ex. 2. Transform equations (1), (2), (3), (4) to rectangular coordinates.

34. THE ELLIPSE. *The ellipse is the locus of a point which moves so that the sum of its distances from two fixed points, called foci, is constant.*

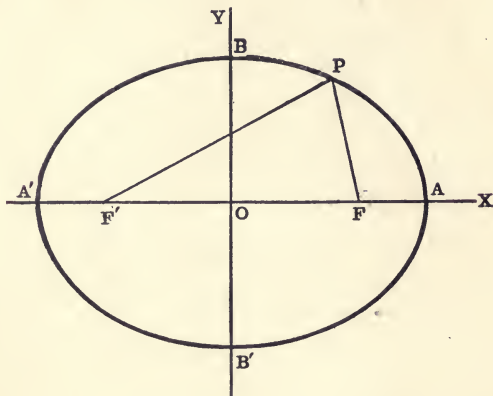

Take the line through the foci as the x -axis, and the point midway between the foci as origin.

Let $2a$ = the sum of the distances from any point on the ellipse to the foci. Let $F(c, 0)$ and $F'(-c, 0)$ be the two foci.

Let $P(x, y)$ be any point on the locus.

Then $FP + F'P = 2a$. [Geometric equation.]

But $FP = \sqrt{(x-c)^2 + y^2}$,

and $F'P = \sqrt{(x+c)^2 + y^2}$. [(2), § 7.]

$$\therefore \sqrt{(x-c)^2 + y^2} + \sqrt{(x+c)^2 + y^2} = 2a. \quad (1)$$

Transposing the first radical and squaring

$$(x+c)^2 + y^2 = 4a^2 + (x-c)^2 + y^2 - 4a\sqrt{(x-c)^2 + y^2},$$

or $a\sqrt{(x-c)^2 + y^2} = a^2 - cx$.

Squaring and transposing again

$$(a^2 - c^2)x^2 + a^2y^2 = a^2(a^2 - c^2).$$

If we put $a^2 - c^2 = b^2$, we get the equation of the ellipse in the standard form,

$$\frac{x^2}{a^2} + \frac{y^2}{b^2} = 1. \quad (2)$$

35. An examination of this equation (2) as to symmetry, limiting values of the variables and intercepts, will give the general form and limits of the curve.

(1) Only the square of the variables x and y appear in this equation.

Therefore the ellipse is symmetrical with respect to both axes, and also with respect to the origin. [(8), § 28.]

Hence every chord passing through O is bisected by O . For this reason, the point O is called the **Centre** of the ellipse. Likewise the lines AA' and BB' are called the **Major Axis** and **Minor Axis**, respectively.

(2) When $y = 0$, $x = \pm a$, x -intercepts.

When $x = 0$, $y = \pm b$, y -intercepts.

Therefore the curve cuts the x -axis a units to the right and a units to the left, the y -axis b units above and b units below the origin.

(3) Solving the equation (2) for y and x respectively we find

$$y = \pm \frac{b}{a} \sqrt{a^2 - x^2}, \quad x = \pm \frac{a}{b} \sqrt{b^2 - y^2}.$$

Hence y is imaginary when $x > a$, or $x < -a$; and x is imaginary when $y > b$, or $y < -b$.

Therefore the curve lies wholly within the rectangle formed by the lines $x = \pm a$ and $y = \pm b$.

Also, as either variable increases, the other diminishes. The form of the curve is shown in the figure.

Such an examination of an equation is called **A Discussion of the Equation**.

Ex. 1. Transform equation (2), § 34, to polar coordinates and show that ρ is finite for all values of θ .

Ex. 2. Where is the point (h, k) if $\frac{h^2}{a^2} + \frac{k^2}{b^2} - 1 > 0$? < 0 ?

Ex. 3. Show the relation of the ellipse $\frac{x^2}{a^2} + \frac{y^2}{b^2} = 1$ to the circles $x^2 + y^2 = a^2$ and $x^2 + y^2 = b^2$.

Ex. 4. Find the axes, coordinates of the foci, and plot the ellipses.

✓ (1) $\frac{x^2}{25} + \frac{y^2}{9} = 1.$

✓ (2) $\frac{x^2}{8} + \frac{y^2}{4} = 1.$

(3) $\frac{x^2}{16} + \frac{y^2}{25} = 1.$

36. THE HYPERBOLA. *The hyperbola is the locus of a point which moves so that the difference of its distances from two fixed points (foci) is constant.*

Choose axes as in the case of the ellipse, let $2a$ be the constant difference, and show that when $b^2 = c^2 - a^2$ the equation of the hyperbola reduces to the standard form. [See Fig. § 90.]

$$\frac{x^2}{a^2} - \frac{y^2}{b^2} = 1. \quad (1)$$

Ex. 1. Discuss equation (1).

Ex. 2. Show that the hyperbola (1) lies wholly between the two straight lines $ay = \pm bx$, and that as x becomes infinite the ordinates of the lines become equal to the ordinates of the hyperbola. These lines are called the **Asymptotes** of the hyperbola. [See Fig. § 110.]

Ex. 3. Transform equation (1) to polar coordinates, and find the value of ρ when $\theta = \pm \tan^{-1} \frac{b}{a}$.

Ex. 4. Find the foci, equations of the asymptotes, and trace the curves

$$\dagger (1) \frac{x^2}{16} - \frac{y^2}{9} = 1. \quad (2) \frac{y^2}{16} - \frac{x^2}{25} = 1. \quad (3) \frac{x^2}{4} - \frac{y^2}{16} = 1.$$

$$\dagger (4) x^2 - y^2 = a^2. \quad (5) y^2 - x^2 = b^2. \quad (6) 4x^2 - y^2 = 4.$$

37. THE PARABOLA. *The parabola is the locus of a point whose distance from a fixed straight line is equal to its distance from a fixed point.*

The fixed point is called the **Focus**; the fixed line is called the **Directrix**.

Take the line through the focus perpendicular to the directrix as the x -axis, and the origin midway between the focus and the directrix; let $2a$ denote the distance from the focus to the directrix. [See Fig. § 88.]

Then show that the equation of the parabola is

$$y^2 = 4ax. \quad (1)$$

Ex. 1. Discuss this equation (1), also $y^2 = -4ax$ and $x^2 = \pm 4ay$.

Find the foci, equations of the directrices, and draw the parabolas

$$(2) y^2 = 4x. \quad (3) y^2 = -8x. \quad (4) y^2 = 6x.$$

$$(5) x^2 = 8y. \quad (6) x^2 = -10y. \quad (7) x^2 = -12y.$$

EXAMPLES

1. A moving point is always four times as far from the x -axis as from the y -axis. What is the equation of its locus? $y = 4x$
2. Find the locus of a point which is equidistant from the two points $(3, 2)$ and $(-2, 1)$. Ans. $5x + y = 4$.
3. Find the locus of a point which is equidistant from the points (a, b) and (c, d) .
4. A point moves so that its distance from the point $(3, -4)$ is always 5. Find the equation of its locus. Does the locus pass through the origin? Why? Ans. $x^2 + y^2 - 6x + 8y = 0$.
5. Find the equation of a circle touching both axes and having its centre at that point $(-3, 3)$.
6. Find the equation of a circle touching both axes and having a radius equal to 4.
7. A point P is two units from a circle with radius 4 and centre at $(2, -6)$. What is the locus of P ?
8. A point moves so that its distance from the origin is twice its distance from the x -axis. What is the equation of its locus? Ans. $x^2 - 3y^2 = 0$.
9. A point moves so that its distance from the x -axis is equal to its distance from the point $(2, -3)$. Show that the equation of its locus is $x^2 - 4x + 6y + 13 = 0$.
10. A point P moves so that its distances from the points $A(2, 2)$ and $B(-2, -2)$ satisfy the condition $AP + BP = 8$. Show that the equation of its locus is $3x^2 - 2xy + 3y^2 = 32$.
11. What is the locus of a point which moves so that (1) the sum, (2) the difference, (3) the product, (4) the quotient of its distances from the axes is constant (a)?
12. What is the locus of a point which moves so that (1) the sum, (2) the difference, (3) the product, (4) the quotient of the squares of its distances from the axes is constant (a^2)?
13. Find the locus of a point which moves so that the sum of the squares of its distances from the points $(a, 0)$ and $(-a, 0)$ is constant ($2c^2$).
14. Find the locus of a point which moves so that the sum of the squares of its distances from the three points $(5, -1)$, $(3, 4)$, $(-2, -3)$ is always 64.
15. Find the locus of a point which moves so that the difference of the squares of its distances from $(a, 0)$ and $(-a, 0)$ is the constant $2c^2$.
16. Find the locus of a point such that the sum of the squares of its distances from the sides of a square is constant.

CHAPTER III

THE STRAIGHT LINE

38. It was shown in § 31 that the equation of any straight line when expressed in terms of its slope m and y -intercept b is an equation of the first degree,

$$y = mx + b;$$

and also that the general equation of the first degree,

$$Ax + By + C = 0,$$

represents a straight line. It is sometimes more convenient, however, to write the equation of the straight line in other forms; *i.e.* to express it in terms of some other *pair* of parameters.

39. *To find the equation of the straight line in terms of its intercepts on the axes.*

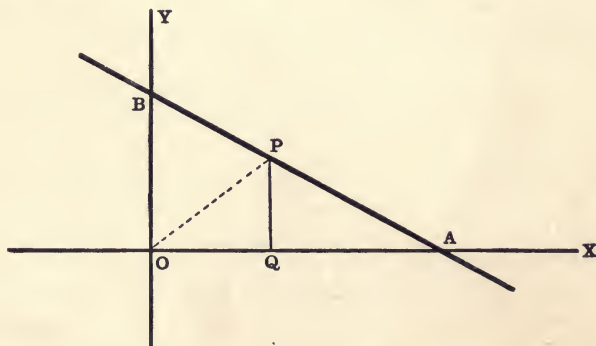

Let A and B be the points in which the straight line meets the axes; let $OA = a$, and $OB = b$. Let $P(x, y)$ be any point on the line.

Draw PQ parallel to the y -axis, and join O and P .

Then $\triangle OAP + \triangle OBP = \triangle OAB$.

Hence $bx + ay = ab$,

or
$$\frac{x}{a} + \frac{y}{b} = 1. \tag{1}$$

If $l = \frac{1}{a}$ and $m = \frac{1}{b}$, the equation may be written

$$lx + my = 1. \quad (2)$$

40. To find the equation of a straight line in terms of the length of the perpendicular from the origin upon the line and the angle which that perpendicular makes with the x -axis.

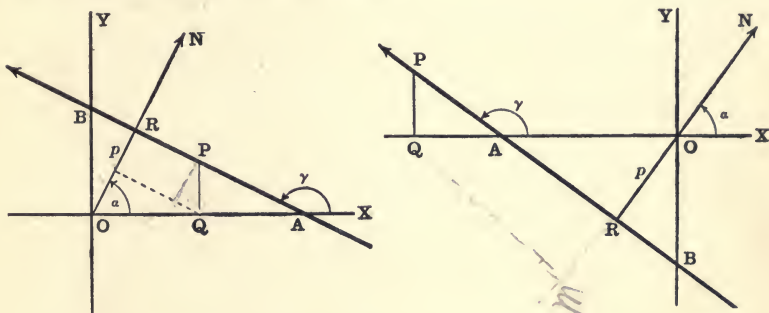

Let ON be perpendicular to the straight line AB , and intersect it in R . Let $OR = p$, and angle $XON = \alpha$.

Let $P(x, y)$ be any point on the line.

Then since $OQPR$ is a closed polygon, OR is equal to the sum of the projections of OQ , QP , and PR upon OR . That is,

$$\begin{aligned} OR &= \text{proj. of } OQ + \text{proj. of } QP + \text{proj. of } PR \\ &= OQ \cos \alpha + QP \sin \alpha + 0. \end{aligned}$$

$$\therefore x \cos \alpha + y \sin \alpha = p, \quad (1)$$

which is the required equation.

Let $\angle XAP = \gamma = 90^\circ + \alpha$. Then $\cos \alpha = \sin \gamma$, $\sin \alpha = -\cos \gamma$, and, by substituting in (1), the equation of the line becomes

$$x \sin \gamma - y \cos \gamma = p. \quad (2)$$

Since equations (1) and (2) involve the trigonometric functions, \sin and \cos , ON and AB must be regarded as *directed* lines. As in Trigonometry, we will consider the directions of the terminal lines of α and γ as the *positive* directions of these lines.

If $\gamma = 90^\circ + \alpha$, as assumed above, then standing at R facing the positive direction of ON , the positive direction of AB is to the *left*;

and standing at R facing the positive direction of AB , the positive direction of ON is from AB toward the right.

This will be called the *positive side* of the line AB .

Then in equations (1) and (2) p is positive when taken in the positive direction of ON . Hence when p is *positive* the *origin* is on the *negative* side of the line.

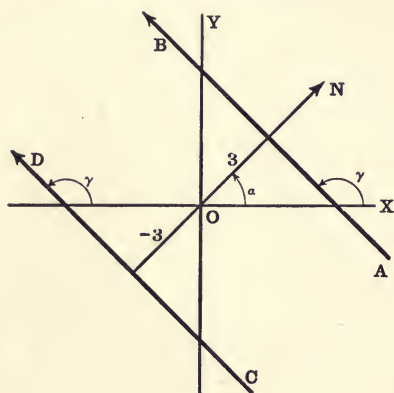

E.g. In the equations

$$\frac{x}{\sqrt{2}} + \frac{y}{\sqrt{2}} = \pm 3,$$

$$\cos \alpha = \sin \alpha = \frac{1}{\sqrt{2}}.$$

$$\therefore \alpha = 45^\circ \text{ and } \gamma = 135^\circ$$

for both lines ; but

for AB $p = 3$,

for CD $p = -3$.

Hence the two lines are parallel but on opposite sides of O . Also O is on the positive side of CD and on the negative side of AB .

Since $\sin(\theta \pm \pi) = -\sin \theta$ and $\cos(\theta \pm \pi) = -\cos \theta$,

if the signs of all the terms in (1), or (2), be changed, the direction of AB , and also of ON , will be changed by $\pm \pi$; and therefore the positive and negative sides of the line will be reversed. That is, the equation of a line may be written so as to make either side of the line positive or negative, just as we choose.

E.g. The equation of the line AB ,

$$\frac{x}{2} - \frac{\sqrt{3}y}{2} = -2, \quad (1)$$

may also be written

$$-\frac{x}{2} + \frac{\sqrt{3}y}{2} = 2. \quad (2)$$

In (1) $p = -2$,

$$\cos \alpha = \sin \gamma = \frac{1}{2},$$

$$\sin \alpha = -\cos \gamma = -\frac{\sqrt{3}}{2}.$$

$$\therefore \alpha = -60^\circ \text{ and } \gamma = 30^\circ.$$

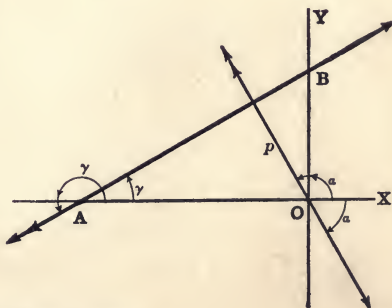

$$\text{In (2) } p = 2, \quad \cos \alpha = \sin \gamma = -\frac{1}{2}, \quad \sin \alpha = -\cos \gamma = \frac{\sqrt{3}}{2}.$$

$$\therefore \alpha \approx 120^\circ \text{ and } \gamma = 210^\circ.$$

Angles and directions corresponding to (1) are denoted by single arrow-heads, those corresponding to (2) by double arrow-heads.

The origin is on the positive or negative side of the line according as the equation is written in the form (1) or (2).

Ex. Point out the combinations of signs of $\cos \alpha$, $\sin \alpha$, and p when the line crosses the different quadrants.

41. Transformation of the equations of the straight line.

In §§ 31, 39, and 40 we have found, by independent methods, the three *standard forms* of the equation of a straight line involving different pairs of parameters, m and b , a and b , α or γ , and p ; viz.:

$$y = mx + b, \quad \textit{Slope form}, \quad (1)$$

$$\frac{x}{a} + \frac{y}{b} = 1, \quad \textit{Intercept form}, \quad (2)$$

$$\left\{ \begin{array}{l} x \cos \alpha + y \sin \alpha = p, \\ x \sin \gamma - y \cos \gamma = p, \end{array} \right\} \quad \textit{Distance, or normal form}. \quad (3)$$

Any one of these forms of the equation may, however, be deduced from any other.

I. From the figure we obtain directly the relations

$$m = \tan \gamma = \frac{\sin \gamma}{\cos \gamma} = -\frac{\cos \alpha}{\sin \alpha} = -\frac{b}{a},$$

$$\text{and } p = a \cos \alpha = b \sin \alpha$$

$$= -b \cos \gamma = a \sin \gamma.$$

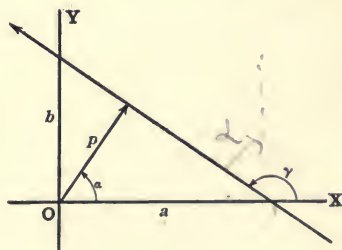

Then substituting these values of m in (1), for example, gives

$$y = -\frac{b}{a}x + b,$$

$$y = -\frac{\cos \alpha}{\sin \alpha}x + b,$$

$$\text{and } y = \frac{\sin \gamma}{\cos \gamma}x + b.$$

Whence, since $b \sin \alpha = -b \cos \gamma = p$, we get

$$\frac{x}{a} + \frac{y}{b} = 1,$$

$$x \cos \alpha + y \sin \alpha = p,$$

and

$$x \sin \gamma - y \cos \gamma = p.$$

Moreover, the general equation of the first degree,

$$Ax + By + C = 0, \quad (4)$$

can be transformed into any one of the three standard forms.

II. Solving (4) for y gives (see § 31)

$$y = -\frac{A}{B}x - \frac{C}{B}. \quad \text{Slope form.} \quad (5)$$

III. If we transpose and divide by C , (4) may be written

$$\frac{x}{-\frac{C}{A}} + \frac{y}{-\frac{C}{B}} = 1. \quad \text{Intercept form.} \quad (6)$$

IV. To reduce the general equation (4) to the distance form.

In this case we are to transform (4) so that the sum of the squares of the resulting coefficients of x and y shall be unity. Hence, if we assume the transformed equation to be

$$KAx + KBy + KC = 0, \quad (7)$$

then

$$K^2A^2 + K^2B^2 = \cos^2 \alpha + \sin^2 \alpha = 1.$$

Whence

$$K = \frac{1}{\sqrt{A^2 + B^2}}.$$

$$\therefore \frac{A}{\sqrt{A^2 + B^2}}x + \frac{B}{\sqrt{A^2 + B^2}}y = -\frac{C}{\sqrt{A^2 + B^2}} \quad (8)$$

is the required equation.

Hence, to reduce the general equation (4) to the distance form, transpose C and divide by $\sqrt{A^2 + B^2}$.

The general equation of the first degree must therefore represent a straight line, since, by transposing and multiplying by a suitable constant, it can be reduced to any one of the standard forms of the equation of the straight line. (Cf. § 31.)

V. Values of parameters in terms of A , B , and C .

Comparing coefficients in (1) and (5), (2) and (6), (3) and (8), we

get
$$a = -\frac{C}{A}, \quad b = -\frac{C}{B}, \quad m = -\frac{A}{B}, \quad p = \frac{-C}{\sqrt{A^2 + B^2}},$$

$$\cos \alpha = \sin \gamma = \frac{A}{\sqrt{A^2 + B^2}}, \quad \sin \alpha = -\cos \gamma = \frac{B}{\sqrt{A^2 + B^2}}.$$

Observe that the values of a and b thus obtained are the same as those found by putting $y = 0$, then $x = 0$ in (4); also that $m = -\frac{A}{B} = -\frac{b}{a}$, as found above directly from the figure. Then $\sin \alpha$, $\cos \alpha$, and p can be found by Trigonometry and the relations obtained from the figure.

EXAMPLES

1. When is it impossible to write the equation of a straight line in the *intercept form*? in the *slope form*?

Change the following equations to the standard forms and thus determine their parameters. Also draw the lines:

2. $x + \sqrt{3}y + 10 = 0.$

3. $4y = 3x + 24.$

4. $y = x - 6.$

5. $5x + 4y = 20.$

6. $5x - 12y = 13.$

7. $2x - 4y + 9 = 0.$

8. $2x - 3y = 4.$

9. $2x + 3y = 0.$

10. $x - a = 0.$

11. $y = 4.$

12. Transform $Ax + By + C = 0$ so that the sum of the three coefficients shall be K ; so that the square of the first shall be three times the second; so that the product of the three shall be twice their sum.

13. Transform $5x + 4y - 20 = 0$ so that the sum of the three coefficients shall be 22; so that the product of the first and third shall be equal to the second.

14. Transform $3x - 4y + 12 = 0$ so that the square of the second coefficient shall be equal to twice the third minus four times the first; so that the product of the three shall be minus three times the last.

15. Transform $5x - 2y - 3 = 0$ so that the product of the first and second coefficients minus ten times the third shall be equal to -40 ; so that the square of the second plus twice the sum of the first and third shall be equal to 24.

where

42. To find the polar equation of a straight line.

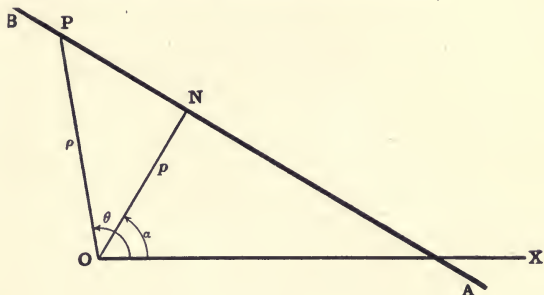

Let $N(p, \alpha)$ be the foot of the perpendicular from O upon the given line AB .

Let $P(\rho, \theta)$ be any other point on AB .

Then $\angle NOP = (\theta - \alpha)$,

and $OP \cos \angle NOP = ON$.

$$\therefore \rho \cos(\theta - \alpha) = p, \quad (1)$$

which is the required equation.

EXAMPLES

Find the parameters and draw the lines whose equations are

1. $\rho \cos(\theta - 30^\circ) = 2$.

2. $\rho \cos(\theta - 60^\circ) = 1$.

3. $\rho \cos(\theta + 45^\circ) = 3$.

4. $\rho \cos(\theta + 120^\circ) + 4 = 0$.

5. $\rho \cos(\theta - 120^\circ) + 1 = 0$.

6. $\rho \cos(\theta + 60^\circ) + 5 = 0$.

7. Transform $x \cos \alpha + y \sin \alpha = p$ to polar coordinates.

8. What is the polar equation of a line perpendicular to the initial line? parallel to the initial line?

9. What is the polar equation of any straight line through the pole? of the initial line?

10. What locus is represented by $\sin \theta = 0$? $\sin 2\theta = 0$? $\sin 3\theta = 0$?
... $\sin n\theta = 0$?

11. What is the locus of $\cos n\theta = 0$ when $n = 1, 2, 3, \dots$?

12. Find the coordinates of the point of intersection of $\rho \cos(\theta \pm 45^\circ) = 1$.

13. Find the polar equations of the bisectors of the angles between the lines
 $\rho \cos(\theta - 60^\circ) = 2$, and $\rho \cos(\theta - 30^\circ) = 2$.

where

43. To find the equation of a straight line passing through a fixed point (x_1, y_1) in a given direction.

Let the line make with the x -axis an angle $\tan^{-1} m$.

Its equation will then be (where b is unknown)

$$y = mx + b; \quad (1)$$

and since the line passes through (x_1, y_1) ,

$$y_1 = mx_1 + b. \quad (2)$$

Whence, by subtracting (2) from (1),

$$y - y_1 = m(x - x_1). \quad (3)$$

The line given by (3) will pass through the point (x_1, y_1) for all values of m ; and may be made to represent any line through (x_1, y_1) by giving to m a suitable value.

If then we know a line passes through a certain point, we may write its equation in the form (3), and determine the value of m from the other condition the line is made to satisfy.

Since $m = \tan \gamma = \frac{\sin \gamma}{\cos \gamma}$ (§ 40), equation (3) may be written in the form

$$\frac{x - x_1}{\cos \gamma} = \frac{y - y_1}{\sin \gamma} = r, \quad (4)$$

where r is the variable distance from the fixed point (x_1, y_1) to any point (x, y) on the line. *This is a very useful formula.*

Let the student prove (4) directly from a figure.

44. To find the equation of a straight line which passes through two given points (x_1, y_1) and (x_2, y_2) .

Since the line passes through (x_1, y_1) , its equation will be of the form [(3), § 43]

$$y - y_1 = m(x - x_1); \quad (1)$$

then, since (x_2, y_2) is also on the line, we have

$$y_2 - y_1 = m(x_2 - x_1). \quad (2)$$

Dividing (1) by (2) gives the required equation

$$\frac{y - y_1}{y_2 - y_1} = \frac{x - x_1}{x_2 - x_1}. \quad (3)$$

Equation (3) may also be written

$$\begin{vmatrix} x, & y, & 1 \\ x_1, & y_1, & 1 \\ x_2, & y_2, & 1 \end{vmatrix} = 0. \quad (4)$$

which is obvious, since the area of the triangle formed by (x_1, y_1) (x_2, y_2) and any other point (x, y) on the line is zero.

EXAMPLES

Find the equation of the straight line

1. if $b = \frac{2}{3}$ and $\gamma = \tan^{-1} \frac{1}{2}$.
2. if $a = b$ and $p = 5$.
3. if $\gamma = 30^\circ$ and $p = 4$.
4. if $b = -3$ and $\gamma = 150^\circ$.
5. if $\gamma = \tan^{-1} 2$ and the line passes through $(3, -4)$.
6. if $\gamma = \tan^{-1} \frac{a}{b}$ and the line passes through $(-a, b)$.
7. passing through the pairs of points $(2, 3)$ and $(-6, 1)$; $(-1, 3)$ and $(6, -7)$; (a, b) and $(a+b, a-b)$.
8. Find the equations of the sides of the triangle whose vertices are the points $(1, 3)$, $(3, -5)$, and $(-1, -3)$.
9. Find the equations of the three medians of this triangle, and show that they meet in a point.
10. Find the equation of a line passing through $(-1, 4)$ and having intercepts (1) equal in length, (2) equal in length but opposite in sign.
11. What is the equation of the line through $(4, -5)$ parallel to $2x + 3y = 6$?
45. To find the angle between two straight lines whose equations are given.

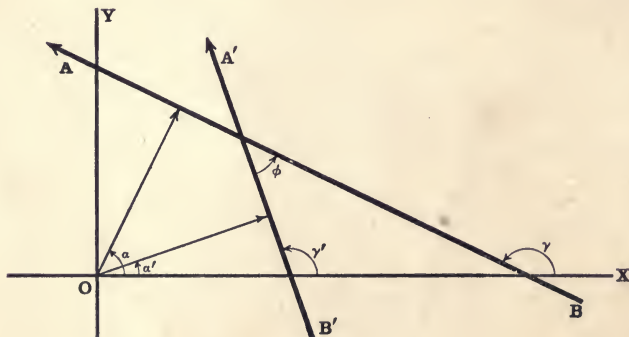

Let AB and $A'B'$ be the given lines.

Let ϕ be the required angle.

Then, using the same notation and the same convention as to direction of the lines as in § 40,

$$\phi = \alpha - \alpha' = \gamma - \gamma'. \quad (1)$$

I. If the equations of the given lines be

$$x \cos \alpha + y \sin \alpha = p \quad \text{and} \quad x \cos \alpha' + y \sin \alpha' = p',$$

$\cos \phi$ can be found by direct substitution in

$$\cos \phi = \cos \alpha \cos \alpha' + \sin \alpha \sin \alpha'. \quad (2)$$

II. If the equations of the given lines be

$$y = mx + b \quad \text{and} \quad y = m'x + b',$$

we have from (1), since $\tan \gamma = m$, and $\tan \gamma' = m'$,

$$\tan \phi = \tan (\gamma - \gamma') = \frac{\tan \gamma - \tan \gamma'}{1 + \tan \gamma \tan \gamma'} = \frac{m - m'}{1 + mm'}. \quad (3)$$

$$\therefore \phi = \tan^{-1} \left(\frac{m - m'}{1 + mm'} \right). \quad (4)$$

When $m = m'$, $\tan \phi = 0$, and the lines are parallel.

When $1 + mm' = 0$, $\tan \phi$ is infinite.

Therefore, when $m' = -\frac{1}{m}$, the lines are perpendicular to one another.

III. If the equations of the lines be

$$Ax + By + C = 0 \quad \text{and} \quad A'x + B'y + C' = 0,$$

then $m = -\frac{A}{B}$, $m' = -\frac{A'}{B'}$; and therefore, from (3),

$$\tan \phi = \frac{A'B - AB'}{AA' + BB'}. \quad (5)$$

If $A'B - AB' = 0$, i.e. if $\frac{A}{A'} = \frac{B}{B'}$, the lines will be parallel.

If $AA' + BB' = 0$, the lines will be at right angles to one another.

It should be noticed that (2) gives the angle between two directed lines. For if all the signs in *one* of the equations in I be changed, the direction of the line will be changed by $\pm \pi$, (§ 40).

The *sign* of $\cos \phi$ given by (2) will also be changed and ϕ becomes the supplement of its former value. But if all the signs in both equations be changed, ϕ is unaltered.

If the equations be so written that the origin is on the *same* side (either positive or negative) of both lines, it will be in the obtuse angle between the lines when $\cos \phi$ is positive, and in the acute angle when $\cos \phi$ is negative.

If m and m' be so taken that $m' > m$, then $\gamma' > \gamma$ and (3) will give $\tan(-\phi) = -\tan \phi = \tan(\pi - \phi)$, instead of $\tan \phi$.

46. To find the equations of two lines passing through a given point (x_1, y_1) , the one parallel, the other perpendicular, to a given line.

Let the given line be

$$Ax + By + C = 0.$$

Then the parallel line is

$$Ax + By + K = 0, \quad [\S 45, \text{III.}] \quad (1)$$

and the perpendicular line is

$$Bx - Ay + K' = 0, \quad [\S 45, \text{III.}] \quad (2)$$

where K and K' are constants to be determined.

Since both (1) and (2) are to go through (x_1, y_1) , these constants are such that

$$\left. \begin{aligned} Ax_1 + By_1 + K &= 0 \\ Bx_1 - Ay_1 + K' &= 0, \end{aligned} \right\} \quad (3)$$

and

$$\left. \begin{aligned} K &= -(Ax_1 + By_1) \\ K' &= -(Bx_1 - Ay_1). \end{aligned} \right\} \quad (4)$$

i.e.

and

Therefore, the required equations are, respectively,

$$A(x - x_1) + B(y - y_1) = 0, \quad (5)$$

and

$$B(x - x_1) - A(y - y_1) = 0. \quad (6)$$

If the equation of the given line is in the form

$$y = mx + b,$$

the required equations may be written [(3), § 43, and II, § 45]

$$y - y_1 = m(x - x_1) \quad (7)$$

and

$$y - y_1 = -\frac{1}{m}(x - x_1). \quad (8)$$

EXAMPLES

Find the angles between the following pairs of lines :

1. $3x + 4y = 8$ and $7y - x + 14 = 0$.
2. $2x + 3y = 6$ and $2y = 3x - 12$.
- ✓ 3. $x + 4 = 2y$ and $x + 3y = 9$.
4. $3y + 12x + 16 = 0$ and $2y = 4x + 5$.
- ✓ 5. $\frac{x}{a} - \frac{y}{b} = 1$ and $\frac{y}{a} - \frac{x}{b} = 1$.
- ✗ 6. Prove that the points $(1, 3)$, $(5, 0)$, $(0, -4)$, and $(-4, -1)$ are the vertices of a parallelogram, and find the angle between its diagonals.

Find the equations of the two straight lines

7. passing through the point $(2, 3)$, the one parallel, the other perpendicular, to the line $4x - 3y = 6$.
- ✓ 8. passing through $(4, -2)$, the one parallel, the other perpendicular, to the line $y = 2x + 4$.
- ✗ 9. passing through the intersection of $4x + y + 5 = 0$ and $2x - 3y + 13 = 0$, one parallel, the other perpendicular, to the line through the two points $(3, 1)$, and $(-1, -2)$.
- ✓ 10. Find the equation of the perpendicular bisector of the line joining the points $(3, -1)$ and $(-2, 1)$.
- ✓ 11. Find the equations of the lines perpendicular to the line joining $(2, 1)$ and $(-3, -2)$ at the points which divide it internally and externally in the ratio $2 : 3$.
- ✓ 12. What is the equation of a line parallel to $3x + 4y = 12$ and at a distance 4 from the origin?

13. Find the point of intersection of two parallel lines. (∞, ∞)

The vertices of a triangle are $(3, 1)$, $(-2, 3)$, and $(2, -4)$:

14. Find the equations of its altitudes and show that they meet in a point.
15. Find the equations of the perpendicular bisectors of its sides, and show that they meet in a point which is equidistant from the three vertices.
16. Find its interior angles.
17. Find the equations of two lines through the origin, each making an angle of 30° with the line $4x + y + 4 = 0$.
- ✓ 18. Show that the equations of the two straight lines through a given point (x_1, y_1) making a given angle ϕ with the line $y = mx + b$ are

$$y - y_1 = \frac{m \pm \tan \phi}{1 \mp m \tan \phi} (x - x_1).$$

47. To find the perpendicular distance from a given straight line to a given point $P_1(x_1, y_1)$.

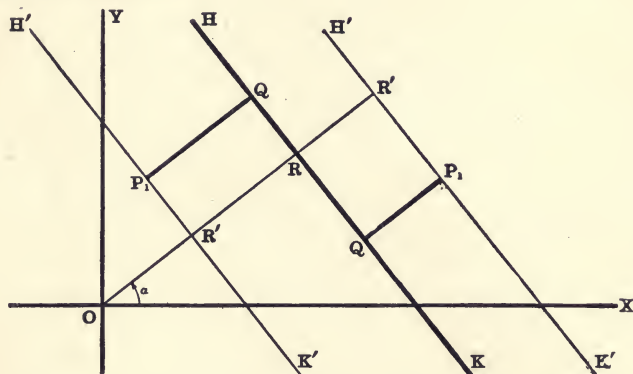

Let HK be the given line, and let $H'K'$ be parallel to HK and pass through P_1 . Let P_1Q be the perpendicular from P_1 on HK , and OR, OR' the perpendiculars from O on HK and $H'K'$.

Let the equation of HK be

$$x \cos \alpha + y \sin \alpha = p. \quad (1)$$

Then the equation of $H'K'$ is

$$x \cos \alpha + y \sin \alpha = p + RR' = p + QP_1; \quad (2)$$

and since this line (2) goes through $P_1(x_1, y_1)$,

$$x_1 \cos \alpha + y_1 \sin \alpha = p + QP_1. \quad (3)$$

$$\therefore QP_1 = x_1 \cos \alpha + y_1 \sin \alpha - p, \quad (4)$$

which is the distance from the line a, p to the point (x_1, y_1) .

If the equation of the given line be

$$Ax + By + C = 0,$$

$$\cos \alpha = \frac{A}{\sqrt{A^2 + B^2}}, \quad \sin \alpha = \frac{B}{\sqrt{A^2 + B^2}}, \quad p = \frac{-C}{\sqrt{A^2 + B^2}}; \quad [\S 41, V.]$$

and substituting these values in (4) gives

$$QP_1 = \frac{Ax_1 + By_1 + C}{\sqrt{A^2 + B^2}}, \quad (5)$$

which is the distance from line A, B, C to the point (x_1, y_1) .

Hence the length of the perpendicular from a given line to a given point is found by substituting the coordinates of the point in the equation of the line reduced to the distance form with all the terms transposed to the first member.

The expression (5) will be positive or negative according as $Ax_1 + By_1 + C$ is positive or negative (if $\sqrt{A^2 + B^2}$ be positive). If $Ax_1 + By_1 + C$ is positive, the point (x_1, y_1) is said to be on the *positive side* of the line $Ax + By + C = 0$; if $Ax_1 + By_1 + C$ is negative, (x_1, y_1) is said to be on the *negative side* of the line. If the equation of the line be written so that p is *positive*, the expression (5) will be found to be positive when P_1 and O are on opposite sides of the line. (Cf. § 40.)

Hence the points (x_1, y_1) and (x_2, y_2) are on the *same side* or *opposite sides* of the line $Ax + By + C = 0$ according as $Ax_1 + By_1 + C$ and $Ax_2 + By_2 + C$ have the *same sign* or *opposite signs*. This proves for the straight line the principles illustrated in §§ 14–20.

48. To find the equations of the bisectors of the angles between the lines

$$Ax + By + C = 0, \quad \text{or} \quad x \cos \alpha + y \sin \alpha - p = 0, \quad (1)$$

$$\text{and} \quad A'x + B'y + C' = 0, \quad \text{or} \quad x \cos \alpha' + y \sin \alpha' - p' = 0. \quad (2)$$

Suppose the equations of the lines written so that the origin is on the *same side* of both lines.

Then for any point (x, y) on the bisector of the angle which includes the origin,

$$\text{Dist. from (1) to } (x, y) = \text{Dist. from (2) to } (x, y);$$

and for any point (x, y) on the other bisector,

$$\text{Dist. from (1) to } (x, y) = - \text{Dist. from (2) to } (x, y).$$

Therefore the required equations are [§ 47]

$$\frac{Ax + By + C}{\sqrt{A^2 + B^2}} = \pm \frac{A'x + B'y + C'}{\sqrt{A'^2 + B'^2}}, \quad (3)$$

$$\text{or} \quad x \cos \alpha + y \sin \alpha - p = \pm (x \cos \alpha' + y \sin \alpha' - p'). \quad (4)$$

Ex. Show that these two lines are perpendicular to each other. [Use (4).]

EXAMPLES

Find the following distances :

1. From $3x + 4y + 10 = 0$ to $(1, 12)$, $(-3, -9)$, $(3, 4)$.
2. From $x - 3y = 7$ to $(3, 2)$, $(6, 3)$, $(2, -5)$.
3. From $5x + 12y = 13$ to $(3, -2)$, $(-3, 2)$, $(4, -7)$.
4. From $b(x - a) + a(y - b) = 0$ to $(-a, -b)$, $(-b, -a)$, (b, a) .
5. From $4(x - 3) = 3(y + 1)$ to $(6, 1)$, $(4, -5)$, $(-7, 2)$.

Are the above points on the same or opposite sides of the lines ?

Find the equations of the bisectors of the angles between the lines

6. $3x + 4y + 12 = 0$ and $4x - 3y = 12$.
7. $3x - 4y + 5 = 0$ and $12x + 5y + 14 = 0$.
8. $y = 2x + 5$ and $x - 2y = 8$.
9. $y = \sqrt{3}x + 3$ and $x + \sqrt{3}y = 9$.
10. Find the lengths of the altitudes of the triangle whose vertices are $(3, 4)$, $(-4, 1)$, and $(-1, -5)$.
- + 11. What is the locus of a point which is 3 units distant from the line $2x - 4y = 9$?

49. *To find the equation of a straight line passing through the intersection of two given straight lines.*

The most obvious method of finding the required equation is to find the coordinates x' , y' of the point of intersection of the two given lines, and then substitute these values in equation (3), § 43.

The following method of dealing with this class of problems is, however, sometimes preferable, both on account of its generality and because it saves the labor of solving the two given equations :

Let the equations of the two given straight lines be

$$Ax + By + C = 0, \quad (1)$$

and $A'x + B'y + C' = 0. \quad (2)$

The required equation is then written

$$Ax + By + C + \lambda(A'x + B'y + C') = 0, \quad (3)$$

where λ is any constant.

Equation (3) is of the first degree, and therefore represents a straight line; if (x', y') is the point common to (1) and (2), we have

$$Ax' + By' + C = 0$$

and

$$A'x' + B'y' + C' = 0.$$

$$\therefore Ax' + By' + C + \lambda(A'x' + B'y' + C') = 0,$$

which shows that the point (x', y') is also on (3).

Hence (3) is the equation of a straight line passing through the point of intersection of the two given lines. Moreover, equation (3) contains one arbitrary parameter, λ , and therefore, by giving a suitable value to λ , the line may be made to satisfy any other given condition; it may, for example, be made to pass through any other given point, may be made parallel, or perpendicular to a given line. Hence equation (3) represents, for different values of λ , all straight lines through the point of intersection of (1) and (2).

The other condition which any particular line is made to satisfy will give an equation for the determination of the value of λ .

Ex. Find the equation of a straight line passing through the point of intersection of $2x + 5y - 4 = 0$ and $4x - 2y + 2 = 0$, and perpendicular to the line

$$2x - 4y = 7. \quad (1)$$

Any line through the intersection is given by

$$2x + 5y - 4 + \lambda(4x - 2y + 2) = 0,$$

or

$$(2 + 4\lambda)x + (5 - 2\lambda)y + (2\lambda - 4) = 0. \quad (2)$$

Now (2) is perpendicular to (1) if (§ 45, III)

$$2(2 + 4\lambda) - 4(5 - 2\lambda) = 0; \text{ i.e. if } \lambda = 1.$$

$$\therefore 6x + 3y = 2 \text{ is the required equation.}$$

EXAMPLES

1. Find the equations of the lines joining the points $(0, 0)$, $(4, 2)$, $(-1, 3)$, $(-3, -4)$ to the point of intersection of the lines $2x + y = 2$ and $2x - 3y = 6$.

2. What is the equation of the straight line passing through the intersection of $4x - 2y = 4$ and $7x - 3y + 21 = 0$, and parallel to $9x - 4y = 0$?

3. Find the equations of the two lines passing through the intersection of $x - 2y = 1$ and $2x + 5y + 4 = 0$, the one parallel, the other perpendicular, to $x + 2y = 0$.

4. Find the equations of the two lines passing through the intersection of $7x - 5y = 35$ and $8x - 3y + 24 = 0$, the one parallel to $y = 2x$, the other perpendicular to $3x + 4y = 0$.

5. Show that if $S = 0$ and $S' = 0$ represent the equations of any two loci with terms all transposed to the first member, and λ denotes an arbitrary constant, then the locus represented by the equation

$$S + \lambda S' = 0$$

will pass through all the common points of the two given loci.

Consider the two cases $\lambda = 0$ and $\lambda = \infty$.

6. Find the equation of the circle which passes through the origin and the common points of the circles

$$x^2 + y^2 = 25 \text{ and } x^2 + y^2 - 18x + 20 = 0.$$

7. Find the equation of the circle which passes through the common points of

$$x^2 + y^2 = 16 \text{ and } x - y = 4,$$

and (1) passes through the origin, (2) touches the x -axis.

50. To find the equation of a straight line referred to axes inclined at an angle ω .

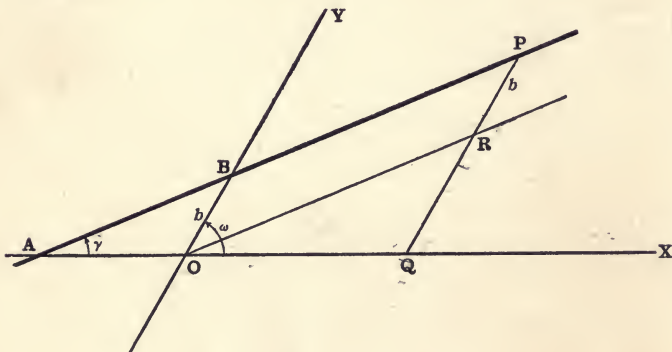

Let ABP be any line meeting the y -axis at a distance b from the origin, and making an angle γ with the x -axis.

Draw PQ parallel to the y -axis and OR parallel to the given line ABP .

Let $P(x, y)$ be any point on the line ABP ; then

$$OQ = x, \text{ and } QR = QP - RP = y - b.$$

Since $\angle ORQ = \angle ROY = \omega - \gamma$, we also have

$$\frac{y-b}{x} = \frac{QR}{OQ} = \frac{\sin QOR}{\sin ORQ} = \frac{\sin \gamma}{\sin (\omega - \gamma)}.$$

$$\therefore y = \frac{\sin \gamma}{\sin (\omega - \gamma)} x + b, \quad (1)$$

which is the required equation.

$$\text{Let } m \equiv \frac{\sin \gamma}{\sin (\omega - \gamma)} = \frac{\tan \gamma}{\sin \omega - \cos \omega \tan \gamma}. \quad (2)$$

$$\text{Then } \tan \gamma = \frac{m \sin \omega}{1 + m \cos \omega}, \quad (3)$$

$$\text{and equation (1) becomes } y = mx + b, \quad (4)$$

which in oblique coordinates represents a straight line inclined to

the x -axis at an angle $\tan^{-1} \left(\frac{m \sin \omega}{1 + m \cos \omega} \right)$.

51. Some of the investigations in the preceding sections of this chapter apply to oblique as well as to rectangular axes. Let the student show that this is true of the following equations:

$$\frac{x}{a} + \frac{y}{b} = 1, \quad [(1), \text{ § 39.}]$$

$$y - y_1 = m(x - x_1), \quad [(3), \text{ § 43.}]$$

$$\frac{y - y_1}{y_2 - y_1} = \frac{x - x_1}{x_2 - x_1}. \quad [(3), \text{ § 44.}]$$

EXAMPLES ON CHAPTER III

1. What are the loci of the following equations?

$$(1) x^2 + axy = 0.$$

$$(2) x^3 - xy^2 = 0.$$

$$(3) x^3 + y^3 = 0.$$

$$(4) x^3 - y^3 = 0.$$

$$(5) a^2x^2 - b^2y^2 = 0.$$

$$(6) a^2x^2 + b^2y^2 = 0.$$

$$(7) (x^2 - 1)(y^2 - 4) = 0.$$

$$(8) (ax + by)^2 = c^2.$$

$$(9) y^2 - (x - a)^2 = 0.$$

$$(10) (x - a)^2 + (y - b)^2 = 0.$$

$$(11) (x - a)^2 - (y - b)^2 = 0.$$

$$(12) x^3 - x^2y + xy^2 - y^3 = 0.$$

$$(13) \rho = a \sec (\theta - \alpha).$$

2. Find the equations of the lines which bisect the opposite sides of the quadrilateral (3, 4), (5, 1), (-3, 4), and (5, -1).

✓ 3. Find the equations of the lines which go through the origin and trisect that portion of the line $3x - 2y = 18$ which is intercepted between the axes.

4. Find the equation of the line through (a, b) parallel to the line joining $(0, -a)$ and $(b, 0)$.

5. Find the equations of the lines which pass through $(-2, 1)$ and cut off equal lengths from the axes.

✓ 6. Show that the three lines $2x - y = 4$, $x + 2y = 7$, and $3x + y = 11$ meet in a point.

7. Show that the three points (1, 3), (-1, 4), and (9, -1) are on a straight line; also $(3a, 0)$, $(0, 3b)$, and $(a, 2b)$.

✓ 8. For what value of m will the line $y = mx - 4$ pass through (4, 2)? be 2 units distant from the origin?

9. A line is 3 units distant from O and makes an angle of 60° with OX . What is its polar equation? its rectangular equation?

10. Find the locus of all points which are equidistant from the two lines $3x - 2y = 8$ and $3x - 2y + 2 = 0$.

✓ 11. What is the distance between the parallel lines

$$3x + 4y = 5 \text{ and } 6x + 8y + 15 = 0?$$

12. Find the points on the axes which are 4 units from the line

$$x - 7y + 21 = 0.$$

✓ 13. Show that the perpendiculars let fall from any point of $22x - 4y = 15$ upon the lines $24x + 7y = 20$ and $4x - 3y = 2$ are equal. Find another line of which this statement is true.

14. Find the perpendicular distance of the point (l, m) from the line through (a, b) perpendicular to $lx + my = 1$.

+ ✓ 15. Show that the bisectors of the interior angles of a triangle meet in a point.

16. Find the locus of a point which is equally distant from the lines

$$5x - 3y = 15 \text{ and } 3y = 5x + 6.$$

✓ 17. Show, by the use of (1), § 42, or by transforming (3), § 43, that the polar equation of a line passing through the fixed point (ρ_1, θ_1) may be written

$$\rho \cos(\theta - \alpha) = \rho_1 \cos(\theta_1 - \alpha).$$

18. Show, directly from a figure, or by transforming (3), § 44, that the polar equation of the straight line which passes through the two fixed points (ρ_1, θ_1) and (ρ_2, θ_2) is

$$\rho_1 \rho_2 \sin(\theta_2 - \theta_1) + \rho_2 \rho \sin(\theta - \theta_2) + \rho \rho_1 \sin(\theta_1 - \theta) = 0.$$

- ✓ 19. Show that the equations

$$A \cos \theta + B \sin \theta + \frac{C}{\rho} = 0, \quad A \cot \theta = K, \quad \forall$$

$$\rho = k \sec(\theta - \alpha), \quad \rho = l \csc(\theta - \beta),$$

represent straight lines.

20. Show that the equations of the lines passing through $(-3, 2)$ and inclined at an angle of 60° to the line $\sqrt{3}y - x = 3$ are

$$x + 3 = 0 \quad \text{and} \quad \sqrt{3}y + x + 3 = 2\sqrt{3}.$$

- ✓ 21. Find the equations of the sides of a square of which the points $(2, 2)$ and $(-2, 1)$ are opposite vertices.

22. What are the equations of the sides of a rhombus if two opposite vertices are at the points $(-1, 3)$ and $(5, -3)$, and the interior angles at these vertices are each 60° ?

- ✓ 23. Prove that the equation of the straight line which passes through the point $(a \cos^3 \theta, a \sin^3 \theta)$ and is perpendicular to the straight line $x \sec \theta + y \csc \theta = a$ is

$$x \cos \theta - y \sin \theta = a \cos 2\theta.$$

24. Show that the equations of the lines passing through the point $(4, 4)$ and whose distance from the origin is 2 are $x(1 \pm \sqrt{7}) + y(1 \mp \sqrt{7}) = 8$.

25. Find the area of the triangle formed by the lines

$$y + 3x = 6, \quad y = 2x - 4, \quad y = 4x + 3.$$

26. Show that the area of the triangle formed by the lines

$$y = m_1x + b_1, \quad y = m_2x + b_2, \quad \text{and} \quad x = 0,$$

is

$$\frac{1}{2} \frac{(b_1 - b_2)^2}{m_1 - m_2}.$$

27. Show that the area of the triangle formed by the lines

$$y = m_1x + b_1, \quad y = m_2x + b_2, \quad \text{and} \quad y = m_3x + b_3$$

is

$$\frac{1}{2} \left[\frac{(b_1 - b_2)^2}{m_1 - m_2} + \frac{(b_2 - b_3)^2}{m_2 - m_3} + \frac{(b_3 - b_1)^2}{m_3 - m_1} \right]. \quad (\text{Use Ex. 26.})$$

28. What is the equation of a line passing through the intersection of $3x - 2y + 12 = 0$ and $x + 4y = 20$, and (a) equally inclined to the axes? (b) whose slope is -2 ?

29. The distance of a line from the origin is 5, and it passes through the intersection of $2x + 3y = 6$ and $3x - 5y + 29 = 0$. Find its equation.

30. Find the equations of the two lines which pass through the intersection of $x + 2y = 0$ and $2x - y + 8 = 0$, and touch the circle

$$x^2 + y^2 = 9.$$

31. Find the equations of the two lines which pass through the intersection of $x + 3y + 9 = 0$ and $3x = y + 13$, and touch the circle

$$(x + 2)^2 + (y - 3)^2 = 25.$$

32. Find the equations of the diagonals of the rectangle whose sides are $x + 2y = 10$, $x + 2y + 2 = 0$, $2x - y = 12$, and $2x - y = 16$, without finding the coordinates of its vertices.

33. A circle passes through the common points of

$$x^2 + y^2 = 25 \text{ and } x - 4y + 13 = 0,$$

and cuts the x -axis in two coincident points. Find its equation.

34. Show that the locus of a point which moves so that the *sum* of its distances from the two lines

$$x \cos \alpha + y \sin \alpha = p \text{ and } x \cos \alpha' + y \sin \alpha' = p'$$

is constant and equal to K is the straight line

$$2x \cos \frac{1}{2}(\alpha + \alpha') + 2y \sin \frac{1}{2}(\alpha + \alpha') = (p + p' + K) \sec \frac{1}{2}(\alpha - \alpha').$$

Show that the locus is parallel to *one* of the bisectors of the angles formed by the two given lines.

Show also that if the *difference* of the distances from the two given lines is constant, the locus is a straight line parallel to the other bisector.

35. If p and p' be the perpendiculars from the origin upon the straight lines whose equations are

$$x \sec \theta + y \csc \theta = a \text{ and } x \cos \theta - y \sin \theta = a \cos 2\theta,$$

prove that

$$4p^2 + p'^2 = a^2.$$

36. Show that the equation of the line passing through the points $(a \cos \alpha, b \sin \alpha)$ and $(a \cos \beta, b \sin \beta)$ is

$$bx \cos \frac{1}{2}(\alpha + \beta) + ay \sin \frac{1}{2}(\alpha + \beta) = ab \cos \frac{1}{2}(\alpha - \beta).$$

37. Show that the equation of the line which passes through the points $(a \sec \alpha, b \tan \alpha)$ and $(a \sec \beta, b \tan \beta)$ is

$$bx \cos \frac{1}{2}(\alpha - \beta) - ay \sin \frac{1}{2}(\alpha + \beta) = ab \cos \frac{1}{2}(\alpha + \beta).$$

38. Show that the three straight lines

$$a_1x + b_1y + c_1 = 0, \quad a_2x + b_2y + c_2 = 0, \quad a_3x + b_3y + c_3 = 0$$

will meet in a point if

$$\begin{vmatrix} a_1 & b_1 & c_1 \\ a_2 & b_2 & c_2 \\ a_3 & b_3 & c_3 \end{vmatrix} = 0.$$

39. Find the determinant expressions for the coordinates of the vertices, and for the area of the triangle formed by the three lines in Ex. 38, and show that the determinant there given is a *square factor* of the determinant expression for the area of the triangle.

From

CHAPTER IV

TRANSFORMATION OF COORDINATES, OR CHANGE OF AXES

52. The formulæ for changing an equation from rectangular to polar coordinates and *vice versa* have already been found in § 6, and their usefulness amply illustrated. Moreover, the equation of a curve in any system of coordinates is sometimes greatly simplified by referring it to a new set of axes of the same system. Hence, it is also desirable to be able to deduce from the equation of a curve referred to one set of axes its equation referred to another set of axes of the same system. Either of these operations is known as a **Transformation of Coordinates, or Change of Axes.**

The equations, which express the relations between the two sets of coordinates of *the same point*, and by means of which these operations are performed, are called **Formulæ of Transformation.**

53. *To move the origin to the point (h, k) without changing the direction of the axes.*

Let OX and OY be any pair of axes inclined at an angle ω , and let $O'X'$ and $O'Y'$ be a new pair parallel respectively to the old. Let P be any point whose coordinates are (x, y) with respect to the original axes, and (x', y') with respect to the new axes.

Then from the figure,

$$OQ = ON + NQ,$$

and $QP = QR + RP.$

But $OQ = x, NQ = x', ON = h,$

$QP = y, RP = y', QR = k.$

$$\therefore \left. \begin{aligned} x &= x' + h, \\ y &= y' + k. \end{aligned} \right\} \quad (1)$$

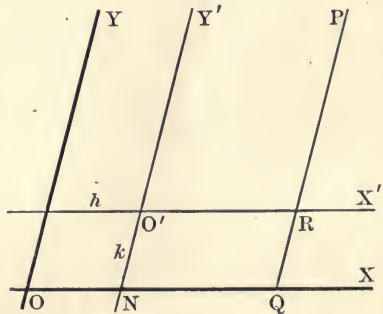

As these equations are independent of ω , they hold for both rectangular and oblique coordinates.

Hence to find what a given equation becomes when the origin is moved to the point (h, k) , the new axes being parallel to the old, substitute $x' + h$ for x and $y' + k$ for y . After the substitution is made we can write x and y instead of x' and y' ; so that practically this transformation is effected by simply writing $x + h$ in the place of x , and $y + k$ in the place of y .

54. To transform from one set of rectangular axes to another, having the same origin.

Let (x, y) be the coordinates of any point P referred to the old axes OX and OY ; and (x', y') the coordinates of the same point referred to the new axes OX' and OY' . Let the angle $XOX' = \theta$.

Draw the ordinates MP and NP , and the lines QN and RN parallel to OX and OY respectively.

$$\begin{aligned} \text{Then } \quad \angle NPQ &= \theta, \\ OM &= x, \quad MP = y, \\ ON &= x', \quad NP = y', \\ OR &= ON \cos \theta = x' \cos \theta, \\ RN &= ON \sin \theta = x' \sin \theta, \\ QN &= NP \sin \theta = y' \sin \theta, \\ QP &= NP \cos \theta = y' \cos \theta. \end{aligned}$$

$$\begin{aligned} \text{But } \quad OM &= OR - QN, \\ \text{and } \quad MP &= RN + QP. \end{aligned}$$

$$\begin{aligned} \text{Therefore} \quad & \left. \begin{aligned} x &= x' \cos \theta - y' \sin \theta, \\ \text{and} \quad y &= x' \sin \theta + y' \cos \theta. \end{aligned} \right\} \quad (1) \end{aligned}$$

If at the same time the origin be changed to the point (h, k) , the required formulæ will be

$$\left. \begin{aligned} x &= x' \cos \theta - y' \sin \theta + h, \\ y &= x' \sin \theta + y' \cos \theta + k. \end{aligned} \right\} \quad (2)$$

This transformation is clearly obtained by combining the two formulæ (1) and (1) of § 53.

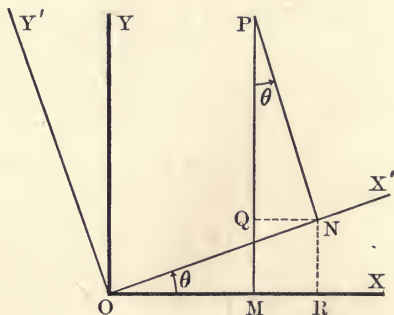

EXAMPLES

Transform to parallel axes through the point $(3, -2)$

1. $y^2 - 4x + 4y + 16 = 0$. 2. $2x^2 + 3y^2 - 12x + 12y + 29 = 0$.

What are the equations of the following loci when referred to parallel axes through the point (a, b) ?

3. $(x - a)^2 + (y - b)^2 = r^2$. 4. $xy - bx - ay + ab = a^2$.
 5. $y^2 - 2by + 4ax = 4a^2 - b^2$. 6. $x^2 - y^2 - 2ax + 2by = b^2 - a^2$.
 7. $b^2(x^2 - 2ax) + a^2(y^2 - 2by) + a^2b^2 = 0$.

Transform by turning rectangular axes through an angle of 45° .

8. $x^2 - y^2 = a^2$. 9. $3x^2 - 2xy + 3y^2 = 32$. (10. p. 45.)
 10. $2(y + x) = (y - x)^3$. 11. $ax^2 + 2hxy + ay^2 = 1$.
 12. $x^{\frac{1}{2}} + y^{\frac{1}{2}} = a^{\frac{1}{2}}$. 13. $(x^2 + y^2)^3 = 4a^2x^2y^2$.

In 13 change the given equation and the result to polar coordinates.

14. Transform $\frac{x}{a} + \frac{y}{b} = 1$ by turning the axes through $\tan^{-1} \frac{a}{b}$.

* 15. What does $2x^2 - 3xy - 2y^2 = 5a^2$ become when the axes are turned through $\tan^{-1} 2$?

16. If the axes be turned through an angle of 30° , what does the equation $9x^2 - 2\sqrt{3}xy + 11y^2 = 4$ become?

* 17. Show that the equation $2x^2 + xy - y^2 + 5x - y + 2 = 0$ can be reduced to $2x^2 + xy - y^2 = 0$, by transforming to parallel axes through a properly chosen point.

Through what angle must the axes be turned to cause the term in xy to disappear from the following equations?

18. $x^2 - 6xy + y^2 = 16$. 19. $8x^2 + 4xy + 5y^2 = 36$.

20. $(4y - 3x)^2 - 20x + 110y = 75$. 21. $ax^2 + 2hxy + by^2 = c$.

22. Show that the transformation $x = \frac{x'}{k}$, $y = \frac{y'}{k}$ simply changes the scale of the curve, k being the factor of magnification.

23. Compare the curves $y = \sin x$ and $y = \frac{1}{2} \sin 2x$.

24. Show that the curve $y = \sin^2 x$ differs only in position and size from $y = \sin x$.

CHAPTER V

SLOPE, TANGENTS, AND NORMALS

55. It sometimes happens that the substitution of a particular value for the variable in a fraction causes both numerator and denominator to vanish, and the fraction takes the form $\frac{0}{0}$.

Thus, $\frac{1 - \sin x}{1 - \csc x}$ becomes $\frac{0}{0}$ when $x = \frac{\pi}{2}$.

The fraction is then said to be *indeterminate*; that is, the fraction has *no value*, or meaning, for this particular value of the variable. Such a fraction, however, usually approaches a *definite limit* as the variable approaches this particular value as its limit. This *limit* is the value we then *assign* to the fraction, because it fits in continuously with the other values of the fraction. This definite limit can be found by reducing the given fraction to an equivalent one whose terms do not both vanish when the particular value is substituted for the variable.

E.g. $\lim_{x \rightarrow 90^\circ} \frac{1 - \sin x}{1 - \csc x} = \lim_{x \rightarrow 90^\circ} (-\sin x) = -1.$

In all the investigations which follow in this chapter it will be found to be necessary to determine the limit which a ratio approaches when its terms both approach zero. Hence the student should now fix in mind the following definition, viz.:

A constant is called the limit of a variable if the difference between the constant and the variable can be made to become and remain as small as we please.

56. *Examples of limiting values of ratios.*

(1) Let K be the area of a square whose side is x .

Then $\left[\lim_{x \rightarrow 0} \frac{K}{x} \right] = \frac{0}{0}$. But $\lim_{x \rightarrow 0} \frac{K}{x} = \lim_{x \rightarrow 0} \frac{x^2}{x} = \lim_{x \rightarrow 0} (x) = 0.$

* The sign " \rightarrow " in these conditions for a limit should be read "approaches."

(2) Let K be the area of a rectangle with a constant base b and a variable altitude x .

$$\text{Then } \left[\frac{\lim K}{\lim x} \right]_{x \neq 0} = \frac{0}{0}. \quad \text{But } \lim_{x \neq 0} \frac{K}{x} = \lim_{x \neq 0} \frac{bx}{x} = b.$$

(3) Let V be the volume, T the total surface, C the circumference of the base of a right circular cylinder whose altitude is constant and radius variable.

$$\text{Then } \left[\frac{\lim T}{\lim C} \right]_{r \neq 0} = \frac{0}{0}, \quad \left[\frac{\lim T}{\lim V} \right]_{r \neq 0} = \frac{0}{0}.$$

$$\text{But } \lim_{r \neq 0} \frac{T}{C} = \lim_{r \neq 0} \frac{2\pi r(r+h)}{2\pi r} = \lim_{r \neq 0} (r+h) = h,$$

$$\text{and } \lim_{r \neq 0} \frac{T}{V} = \lim_{r \neq 0} \frac{2\pi r(r+h)}{\pi r^2 h} = \lim_{r \neq 0} \frac{2(r+h)}{rh} = \frac{2h}{0} = \infty.$$

If S be the convex surface, find $\lim_{r \neq 0} \frac{T}{S}$.

$$(4) \quad \left[\frac{\lim (x-a)^2}{\lim (x^2-a^2)} \right]_{x \neq a} = \frac{0}{0};$$

$$\text{but } \lim_{x \neq a} \frac{(x-a)^2}{x^2-a^2} = \lim_{x \neq a} \frac{x-a}{x+a} = 0.$$

$$(5) \text{ Find } \lim_{x \neq 0} \frac{1-\sqrt{1-x^2}}{x^2}.$$

Multiplying both numerator and denominator by $1+\sqrt{1-x^2}$ gives

$$\lim_{x \neq 0} \frac{1-\sqrt{1-x^2}}{x^2} = \lim_{x \neq 0} \frac{x^2}{x^2(1+\sqrt{1-x^2})} = \lim_{x \neq 0} \frac{1}{1+\sqrt{1-x^2}} = \frac{1}{2}.$$

EXAMPLES

Find the limits indicated in the following expressions :

$$1. \quad \lim_{x \neq a} \frac{x^3 - a^3}{x^2 - a^2}.$$

$$2. \quad \lim_{x \neq a} \frac{x^4 - a^4}{x^2 - a^2}.$$

$$3. \quad \lim_{x \neq a} \frac{(x-a)^3}{x^3 - ax^2 - a^2x + a^3}.$$

$$4. \quad \lim_{x \neq 1} \frac{3x^2 - 6x + 3}{2x^2 - 4x + 2}.$$

$$5. \quad \lim_{x \neq 0} \frac{x^2}{a - \sqrt{a^2 - x^2}}.$$

$$6. \quad \lim_{x \neq \infty} \frac{2x^2 + x - 1}{x^2 - x + 2}.$$

$$7. \quad \lim_{x \neq 0} \frac{\sqrt{4+x} - \sqrt{4-x}}{x}.$$

$$8. \quad \lim_{x \neq \infty} \sqrt{a^2 + x^2} - x.$$

$$9. \quad \lim_{x \neq 0} \frac{\sin x}{\tan x} = 1.$$

$$10. \quad \lim_{x \neq 90^\circ} \frac{\sec x}{\tan x} = 1.$$

$$11. \quad \lim_{x \neq 0} \frac{1 - \cos x}{\sin^2 x} = \frac{1}{2}.$$

$$12. \quad \lim_{x \neq 0} \frac{\tan x - \sin x}{1 - \cos x} = 0.$$

$$13. \quad \lim_{x \neq 0} \frac{\sin x}{x} = \lim_{x \neq 0} \frac{\tan x}{x} = 1.$$

$$14. \quad \lim_{x \neq 0} \frac{\sec x - 1}{x^2} = \frac{1}{2}.$$

15. If V be the volume, T the total surface, S the convex surface, C the circumference of the base of a cone of revolution whose altitude h is constant,

show that $\lim_{r \neq 0} \frac{T}{C} = \frac{h}{2}$, $\lim_{r \neq 0} \frac{T}{V} = \infty$, $\lim_{r \neq 0} \frac{T}{S} = 1$, $\lim_{r \neq \infty} \frac{T}{S} = 2$.

57. DEFINITIONS. Let two points P and Q be taken on any curve PQR , and let the point Q move along the curve nearer and nearer to P ; the limiting position, TT' , of the secant PQ when the point Q approaches indefinitely near to P is called the **Tangent** to the curve at the point P .

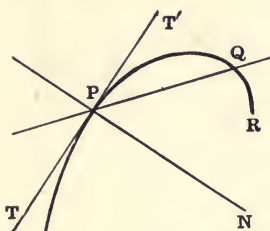

The straight line PN through the point P , perpendicular to the tangent TT' , is called the **Normal** to the curve at the point P .

The **Slope**, or **Gradient**, of a curve at any point is the slope of the straight line tangent to the curve at that point.

58. *To find the slope of a curve at any point.**

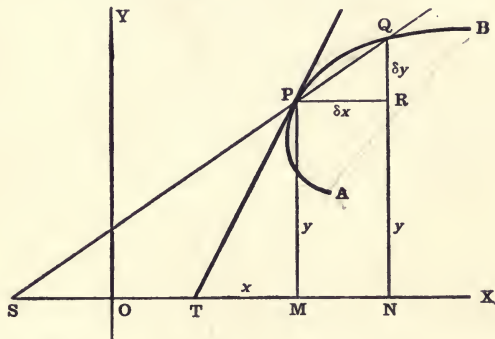

Let $P(x, y)$ and $Q(x + \delta x, y + \delta y)$ be two points close together on any curve AB ; then δx is the difference of the abscissas, δy the difference of the ordinates of P and Q .

Let the secant PQ meet the x -axis in S , and let the tangent line at P meet the x -axis in T .

Draw the ordinates MP, NQ , and draw PR parallel to the x -axis.

Then $PR = \delta x, RQ = \delta y$.

Let the equation of the curve be

$$y = f(x). \quad (1)$$

* Read Ex. 1, § 59, in connection with this general demonstration.

Then at the points P and Q we have

$$\begin{aligned} OM &= x, & MP &= y = f(x), \\ ON &= x + \delta x, & NQ &= y + \delta y = f(x + \delta x). \\ \therefore \delta y &= f(x + \delta x) - f(x). \end{aligned}$$

Also $\tan XSQ = \tan RPQ = \frac{RQ}{PR} = \frac{\delta y}{\delta x}$.

$$\therefore \tan XSQ = \frac{\delta y}{\delta x} = \frac{f(x + \delta x) - f(x)}{\delta x}. \quad (2)$$

The slope of the tangent TP , which is the slope of the curve at the point P , is the ultimate slope of the secant SPQ when the point Q moves along the curve close up to P ; *i.e.*

$$\tan XTP = \lim \tan XSQ = \lim \frac{\delta y}{\delta x} \text{ as } Q \text{ approaches } P.$$

When the point Q approaches the position of P as a limit, the differences δx and δy simultaneously approach zero as a limit, and the *limiting value of the ratio* $\frac{\delta y}{\delta x}$ is denoted by $\frac{dy}{dx}$; therefore in the limit we have

$$\tan XTP = \frac{dy}{dx} = \lim_{\delta x \rightarrow 0} \frac{f(x + \delta x) - f(x)}{\delta x}. \quad (3)$$

The ratio represented by the last member of equation (3) is also a function of x ; and if, x being regarded as fixed, this ratio has a definite limiting value as δx approaches zero, this limiting value is called the **Derived Function**, or the **Derivative** of $f(x)$ with respect to x , and will be denoted by $f'(x)$, or $D_x[f(x)]$;

i.e. if $y = f(x)$, then $\frac{dy}{dx} \equiv f'(x) \equiv D_x[f(x)]$.

Hence to find the slope at any point of a curve whose equation is in the form $y = f(x)$ we find $f'(x)$, the derivative of $f(x)$ with respect to x , and in this substitute the *abscissa of the given point*.

To find the derivative of a function of x , denoted by $f(x)$, we assign a small increment δx to x , producing an increment, denoted by $f(x + \delta x) - f(x)$, in the function, and then find the limiting value of the ratio

$$\frac{f(x + \delta x) - f(x)}{\delta x}, \text{ as } \delta x \rightarrow 0.$$

59. Examples of derivatives and slope of curves.

Ex. 1. Find the slope of the curve whose equation is

$$y = x^2 + a. \quad (1)$$

Let $P(x, y)$ and $Q(x + \delta x, y + \delta y)$ be any two points close together on the curve; and let TP be the tangent at P .

$$\text{Then at } P, \quad y = x^2 + a, \quad (2)$$

$$\text{and at } Q, \quad y + \delta y = (x + \delta x)^2 + a. \quad (3)$$

Whence

$$\begin{aligned} \frac{(y + \delta y) - y}{\delta x} &= \frac{(x + \delta x)^2 + a - (x^2 + a)}{\delta x} \\ &= \tan RPQ. \end{aligned} \quad (4)$$

$$\therefore \frac{\delta y}{\delta x} = 2x + \delta x = \tan XSQ. \quad (5)$$

When Q approaches P , or as we say, proceeding to the limit $\delta x \doteq 0$, we have (§ 58)

$$\frac{dy}{dx} = 2x = \tan XTP. \quad (6)$$

Hence the slope of the curve at any point is equal to twice the abscissa of the point.

At P_0 , $x = 0$.

$\therefore P_0T_0$ is parallel to the x -axis.

At P_1 , $x = \frac{1}{2}$,

$\therefore \tan XT_1P_1 = 1$.

At P_2 , $x = \frac{3}{2}$,

$\therefore \tan XT_2P_2 = 3$.

At P_3 , $x = -\frac{1}{2}$,

$\therefore \tan XT_3P_3 = -1$.

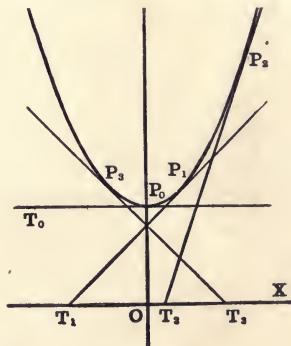

Ex. 2. Let the equation of the given curve be $y = x^5$.

In this example we have given $f(x) \equiv x^5$. Then from the definition of the derivative given in equation (3) of § 58, we have,

$$\begin{aligned} f'(x) &= \lim_{\delta x \doteq 0} \frac{f(x + \delta x) - f(x)}{\delta x} = \lim_{\delta x \doteq 0} \frac{(x + \delta x)^5 - x^5}{\delta x} \\ &= \lim_{\delta x \doteq 0} (5x^4 + 10x^3\delta x + 10x^2\delta x^2 + 5x\delta x^3 + \delta x^4) = 5x^4. \end{aligned}$$

That is, the slope of this curve at any point (x, y) on the curve is equal to five times the fourth power of the abscissa of the point.

Ex. 3. Find the slope of the curve $y = \frac{1}{x}$.

We now have from the definition of a derivative, since $f(x) \equiv \frac{1}{x}$,

$$\begin{aligned} \frac{dy}{dx} &= \lim_{\delta x \doteq 0} \frac{\frac{1}{x + \delta x} - \frac{1}{x}}{\delta x} = \lim_{\delta x \doteq 0} \frac{x - (x + \delta x)}{x(x + \delta x)\delta x}, \\ &= \lim_{\delta x \doteq 0} \frac{-1}{x(x + \delta x)} = -\frac{1}{x^2}. \end{aligned}$$

That is, the slope is always negative and varies inversely as the square of the abscissa of the point.

Ex. 4. Let $y = \sqrt{x}$ be the given curve.

Then, since $f(x) \equiv \sqrt{x}$, we have from the definition

$$\begin{aligned} \frac{dy}{dx} &= \lim_{\delta x \doteq 0} \frac{f(x + \delta x) - f(x)}{\delta x} = \lim_{\delta x \doteq 0} \frac{\sqrt{x + \delta x} - \sqrt{x}}{\delta x}, \\ &= \lim_{\delta x \doteq 0} \frac{1}{\sqrt{x + \delta x} + \sqrt{x}} = \frac{1}{2\sqrt{x}}. \end{aligned}$$

Ex. 5. To find the derivatives of $\sin x$ and $\cos x$.

Let $\delta x \equiv h$, for convenience, then will

$$D_x(\sin x) = \lim_{h \doteq 0} \frac{\sin(x + h) - \sin x}{h} = \lim_{h \doteq 0} \left[\cos\left(x + \frac{h}{2}\right) \frac{\sin \frac{1}{2} h}{\frac{1}{2} h} \right]$$

i.e. $D_x(\sin x) = \cos x$; (Ex. 13, p. 71.)

$$D_x(\cos x) = \lim_{h \doteq 0} \frac{\cos(x + h) - \cos x}{h} = \lim_{h \doteq 0} \left[-\sin\left(x + \frac{h}{2}\right) \frac{\sin \frac{1}{2} h}{\frac{1}{2} h} \right]$$

i.e. $D_x(\cos x) = -\sin x$.

Check the results found in Exs. 2, 3, 4, and 5 by constructing the loci.

EXAMPLES

Find the slope at the points where $x = 0, \pm 1, \pm 2$, etc., of the curves whose equations are

- ✓ 1. $y = x^3$. ✓ 2. $y = x^4$. ✓ 3. $x^2y = 1$. 4. $y^2 = x^3$.
 ✓ 5. $y = x^3 - 4x$. ✓ 6. $y = x^4 - 20x^2 + 64$. ✗ 7. $y = \frac{(x-1)}{x-2}$.

8. Find the slope of $y = \sqrt{a^2 + x^2}$, where $x = 0, \pm a, \infty$.

9. Find the slope of $y = \sqrt{a^2 - x^2}$, where $x = 0, \pm a, \pm \frac{1}{2}a$.

10. Find the slope of $10y = x^2 - 3x - 20$, where $x = 0, \pm 1, \pm 4$. [§ 22.]

GENERAL FORMULÆ FOR DIFFERENTIATION

60. *The derivative of the product, and sum, of two functions.*

Let $\phi(x)$ and $F(x)$ be any two functions of x . Then (§ 58)

$$D_x[\phi(x)F(x)] = \lim_{\delta x \doteq 0} \frac{\phi(x + \delta x)F(x + \delta x) - \phi(x)F(x)}{\delta x}. \quad (1)$$

Introducing $\phi(x + \delta x)F(x) - \phi(x + \delta x)F(x)$ in the numerator gives

$$D_x[\phi(x)F(x)] =$$

$$= \lim_{\delta x \doteq 0} \left[\phi(x + \delta x) \frac{F(x + \delta x) - F(x)}{\delta x} + F(x) \frac{\phi(x + \delta x) - \phi(x)}{\delta x} \right], \quad (2)$$

$$\text{i.e.} \quad D_x[\phi(x)F(x)] = \phi(x)F'(x) + F(x)\phi'(x). \quad [(3), \text{ § 58.}] \quad (3)$$

By an extension of this process it can be shown that

$$D_x[\phi_1(x)\phi_2(x)\phi_3(x)\dots] = \phi_1'(x)\phi_2(x)\phi_3(x)\dots + \phi_2'(x)\phi_1(x)\phi_3(x)\dots + \phi_3'(x)\phi_1(x)\phi_2(x)\dots + \dots \quad (4)$$

Or, as a special case of (4), we have, if n is a positive integer,

$$D_x[\phi(x)]^n = D_x[\phi(x)\phi(x)\phi(x)\dots \text{ to } n \text{ factors}] \quad (5)$$

$$= [\phi(x)]^{n-1}\phi'(x) + [\phi(x)]^{n-1}\phi'(x) + \dots \text{ to } n \text{ terms} \quad (6)$$

$$\therefore D_x[\phi(x)]^n = n[\phi(x)]^{n-1}\phi'(x). \quad (7)$$

$$\text{E.g.} \quad D_x(\sin x)^3 = 3(\sin x)^2 D_x(\sin x) = 3 \sin^2 x \cos x. \quad [\text{Ex. 5, p. 75.}]$$

One of the most important results that follows from (7) is

$$D_x(x^n) = nx^{n-1}. \quad (8)$$

In like manner it can easily be shown that

$$D_x[cf(x)] = cf'(x), \text{ where } c \text{ is a constant,} \quad (9)$$

$$\text{and } D_x[\phi_1(x) + \phi_2(x) + \phi_3(x) + \dots] = \phi_1'(x) + \phi_2'(x) + \phi_3'(x) + \dots \quad (10)$$

Hence, if $f(x)$ is a rational and integral algebraic function of x (§ 63), $f'(x)$ is found by multiplying the coefficient of each term by the exponent of x in that term and diminishing each exponent by unity.

$$\text{E.g.} \quad D_x[x^4 - 2x^3 + 4x^2 - 3x + 5] = 4x^3 - 6x^2 + 8x - 3.$$

61. To find the derivative of a function of the type $F(x, y) = 0$.

When we desire to differentiate a function of the type $F(x, y) = 0$, we may try first to solve the equation with respect to y , so as to put it in the form $y = f(x)$; or to solve with respect to x , so as to bring it to the form $x = f_1(y)$. It is useful, however, to have a rule to meet cases when this process would be inconvenient or impracticable. It will be sufficient for the purpose of this book to illustrate the rule by considering the general equation of the second degree (§ 87).

$$\text{Let } F(x, y) \equiv ax^2 + 2hxy + by^2 + 2gx + 2fy + c = 0. \quad (1)$$

Let $P(x, y)$ and $Q(x + \delta x, y + \delta y)$ be two points close together on the locus of (1); then at P and Q , respectively,

$$ax^2 + 2hxy + by^2 + 2gx + 2fy + c = 0, \quad (2)$$

$$a(x + \delta x)^2 + 2h(x + \delta x)(y + \delta y) + b(y + \delta y)^2 + 2g(x + \delta x) + 2f(y + \delta y) + c = 0. \quad (3)$$

Subtracting (2) from (3) gives

$$a(2x\delta x + \delta x^2) + 2h(y\delta x + x\delta y + \delta x\delta y) + b(2y\delta y + \delta y^2) + 2g\delta x + 2f\delta y = 0. \quad (4)$$

$$\text{Whence } \frac{\delta y}{\delta x} = -\frac{2ax + 2hy + 2g + a\delta x + h\delta y}{2hx + 2by + 2f + b\delta y + h\delta x}. \quad (5)$$

In the limit when δx and δy approach zero, we have

$$\frac{dy}{dx} = -\frac{ax + hy + g}{hx + by + f}. \quad (6)$$

Now apply to (1) the rule deduced in § 60 and differentiate first with respect to x regarding y as constant; then differentiate with respect to y regarding x as constant. Denoting these partial derivatives respectively by $F_x'(x, y)$ and $F_y'(x, y)$, we thus obtain

$$F_x'(x, y) = 2(ax + hy + g), \quad (7)$$

$$\text{and } F_y'(x, y) = 2(hx + by + f). \quad (8)$$

$$\therefore \frac{dy}{dx} = -\frac{F_x'(x, y)}{F_y'(x, y)} = -\frac{ax + hy + g}{hx + by + f}. \quad (9)$$

It can be proved that this formula (9) expresses the rule for differentiating any function of the type $F(x, y) = 0$.

TANGENTS AND NORMALS

62. To find the equations of the tangent, and the normal at any point (x', y') of a curve.

For the tangent,
$$m = \frac{dy'}{dx'} \quad (\S 58.)$$

For the normal,
$$m = -\frac{dx'}{dy'} \quad (\S 57 \text{ and } \S 45.)$$

The primes in $\frac{dy'}{dx'}$ denote that the coordinates x', y' of the point of contact are to be substituted in the derivative of the equation.

Since both lines pass through the point (x', y') , the equation of the tangent is (§ 46)

$$y - y' = \frac{dy'}{dx'} (x - x'); \quad (1)$$

and the equation of the normal is

$$y - y' = -\frac{dx'}{dy'} (x - x'). \quad (2)$$

COR. If the axes are oblique,

$$\frac{dy}{dx} = \frac{\sin \gamma}{\sin (\omega - \gamma)} = m. \quad (\S 50.)$$

Hence equation (1) holds also for oblique axes.*

EXAMPLES ON CHAPTER V

Find the equations of the tangent and the normal to the curve.

1. $x^2 + y^2 = 25$ at $(3, 4)$.
2. $x^2 + y^2 = 169$ at $(-12, 5)$.
3. $y^2 = 8x$ at $(2, 4)$, $(8, 8)$.
4. $6y + x^2 = 0$, at $(6, -6)$.
5. $y = x^3 - 4x$ at $(2, 0)$, $(-1, 3)$.
6. $y^3 = x^2$, at $(-8, 4)$.
7. $x^2 + y^2 - 4x + 6y = 0$ at the points where $x = 0$.
8. $x^2 + y^2 + 4x - 6y = 12$ at the points where $x = 2$, $x = -6$.
9. $x^2 + y^2 - 8x - 4y + 15 = 0$ at the points where $x = 3$, $x = 5$.
10. $x^2 + y^2 - 16x - 8y + 55 = 0$ at the points where $x = 3$, $x = 5$.

* The theory of this chapter proves what has hitherto been assumed (see note on logic of plotting, § 21), viz., that loci of equations are usually smooth curves without sudden changes in slope or curvature. For, since the slope of a curve $f(x, y) = 0$ at any point (x, y) is a function of x and y , a small change in x and y will ordinarily produce only a small change in the slope.

Find the equation of the tangent to each of the following curves at the point (x', y') :

11. $y = x^2$.

Ans. $\frac{2x}{x'} - \frac{y}{y'} = 1$.

✓ 12. $y^2 = x$.

Ans. $\frac{2y}{y'} - \frac{x}{x'} = 1$.

13. $y = x^3$.

Ans. $\frac{3x}{2x'} - \frac{y}{2y'} = 1$.

✓ 14. $y^2 = x^3$.

Ans. $\frac{3x}{x'} - \frac{2y}{y'} = 1$.

15. $xy = 1$.

Ans. $\frac{x}{2x'} + \frac{y}{2y'} = 1$.

✓ 16. $x^2 + y^2 = 1$.

Ans. $xx' + yy' = 1$.

17. $x^2 - y^2 = 1$.

18. $x^3 + y^3 = 1$.

Ans. $xx'^2 + yy'^2 = 1$.

19. $\frac{x^2}{a^2} + \frac{y^2}{b^2} = 1$.

20. $x^n + y^n = 1$.

21. What are the equations of the tangents to 16, 17, 18, 20 at the point $(1, 0)$; and to 16, 18, 20 at the point $(0, 1)$?

Find the equation of the tangent to

22. $y^4 = 4x - 3x^2$, at the point $(1, 1)$.

23. $10y = (x + 1)^2$ at the point where $x = 9$. (Ex. 11, p. 27.)

24. $4(x + 1) = (y - 2)^2$ at the point where $x = 3$. (Ex. 11, p. 27.)

25. $(x - 8)^2 + (y - 2)^2 = 25$ at the points where $x = 4$.

26. $x(x^2 + y^2) = a(x^2 - y^2)$ at the point where $x = 0$, and $\pm a$.

27. Find the equation of the tangent to $\left(\frac{x}{a}\right)^n + \left(\frac{y}{b}\right)^n = 2$, and show that at the point (a, b) it is the same for all values of n .

28. Show that the curve $x^{\frac{2}{3}} + y^{\frac{2}{3}} = a^{\frac{2}{3}}$ becomes steeper as it approaches the y -axis, and is tangent to the axes at the points $(\pm a, 0)$ and $(0, \pm a)$.

29. Let $y = f(x)$ and $y = F(x)$ be two curves intersecting in the point (x_1, y_1) , and let ϕ be the angle at which they intersect. Show that

$$\tan \phi = \frac{f'(x_1) - F'(x_1)}{1 + f'(x_1) \cdot F'(x_1)}$$

What is the condition that the two curves shall meet at right angles? be tangent to each other?

[The angle at which two curves intersect is the angle between their tangents at the point of intersection of the curves.]

30. Find the angle of intersection between the parabolas

$$y^2 = 4ax \text{ and } x^2 = 4ay.$$

31. Show that the confocal parabolas

$$y^2 = 4a(x+a) \text{ and } y^2 = -4b(x-b)$$

intersect at right angles.

32. At what angle do the rectangular hyperbolas

$$x^2 - y^2 = a^2 \text{ and } xy = b$$

intersect? Draw several sets of these curves by assigning different values to a and b .

33. Find the angle at which the circle $x^2 + y^2 + 2x = 12$ intersects the parabola $y^2 = 9x$.

- † 34. Find the angle of intersection between $x^2 + y^2 = 25$ and $4y^2 = 9x$.

- † 35. Find the equations of the tangent and the normal to the parabola $y^2 = 4x$ at the point $(4, 4)$.

Also find the angle at which the normal meets the curve at its other point of intersection with the curve.

36. Find the derivative of the quotient of two functions.

Let $y = \frac{f(x)}{\phi(x)}$, and write h in the place of δx . (1)

Then $\frac{dy}{dx} = \lim_{h \rightarrow 0} \left\{ \left[\frac{f(x+h)}{\phi(x+h)} - \frac{f(x)}{\phi(x)} \right] \div h \right\}$. (2)

$$= \lim_{h \rightarrow 0} \left[\frac{\phi(x)f(x+h) - f(x)\phi(x+h)}{h\phi(x)\phi(x+h)} \right]. \quad (3)$$

Introducing $\phi(x)f(x) - \phi(x)f(x)$ in the numerator gives

$$\frac{dy}{dx} = \lim_{h \rightarrow 0} \left\{ \frac{\phi(x) \left[\frac{f(x+h) - f(x)}{h} \right] - f(x) \left[\frac{\phi(x+h) - \phi(x)}{h} \right]}{\phi(x)\phi(x+h)} \right\}. \quad (4)$$

$$\therefore D_x \left[\frac{f(x)}{\phi(x)} \right] = \frac{\phi(x)f'(x) - f(x)\phi'(x)}{[\phi(x)]^2}. \quad (5)$$

Find the derivatives of the following functions :

37. $\frac{x-a}{x+a}$ Ans. $\frac{2a}{(x+a)^2}$

38. $\frac{2x+3}{x+1}$ Ans. $\frac{-1}{(x+1)^2}$

39. $\frac{1+x^2}{1-x^2}$

40. $\frac{x^3}{x^2-1} - \frac{x^2}{x-1}$ Ans. $\frac{2x}{(x^2-1)^2}$

41. $\frac{a-2bx}{(a-bx)^2}$

42. $\frac{x^n}{(1+x)^n}$

43. Show that formula (7), § 60, holds (a) when n is a negative integer, and (b) when n is a rational fraction.

[To prove (a) use the formula in Ex. 36; for (b) use (9), § 61.]

44. Prove $D_x \left[\frac{1}{f(x)} \right] = - \frac{f'(x)}{[f(x)]^2}$.

45. Prove $D_x \sqrt{f(x)} = \frac{f'(x)}{2\sqrt{f(x)}}$.

46. Prove $D_x \left[\frac{1}{a^2 - x^2} \right] = \frac{2x}{(a^2 - x^2)^2}$.

47. Prove $D_x \sqrt{a^2 - x^2} = \frac{-x}{\sqrt{a^2 - x^2}}$.

✕ 48. Show that $D_x(\tan x) = \sec^2 x$.

Let $y = \tan x = \frac{\sin x}{\cos x}$. Then from (5), Ex. 36, we get

$$\frac{dy}{dx} = \frac{\cos x \cdot D_x(\sin x) - \sin x \cdot D_x(\cos x)}{\cos^2 x}.$$

But $D_x(\sin x) = \cos x$, and $D_x(\cos x) = -\sin x$. [Ex. 5, p. 75.]

$$\therefore \frac{dy}{dx} = \frac{\cos^2 x + \sin^2 x}{\cos^2 x} = \frac{1}{\cos^2 x} = \sec^2 x.$$

Prove the following formulæ:

✕ 49. $D_x(\cot x) = -\csc^2 x$.

✕ 50. $D_x(\sec x) = \sec x \tan x$.

✕ 51. $D_x(\csc x) = -\csc x \cot x$.

✕ 52. $D_x(\sin x \cos x) = \cos 2x$.

Find the derivatives of the following functions:

53. $\cos^2 x$.

54. $\sin x - \frac{1}{3} \sin^3 x$.

Ans. $\cos^2 x$.

55. $\tan x - x$.

56. $3 \tan x + \tan^3 x$.

57. $x \sin x + \cos x$.

58. $\cos^3 x - 3 \cos x$.

Ans. $3 \sin^3 x$.

59. $\sec^4 x - \tan^2 x$.

61. $(x^2 + a)(x^2 + b)$.

60. $(ax^2 + b)^3$.

Ans. $6ax(ax^2 + b)^2$.

63. $\frac{a^2 - x^2}{a^2 + x^2}$.

62. $(a + x^3)(b + 3x^2)$.

64. $\tan 2x \equiv \frac{2 \sin x \cos x}{1 - 2 \sin^2 x}$.

Ans. $2 \sec^2 2x$.

65. $(a + x)\sqrt{a - x}$.

67. $x^2 \sqrt{1 + x^2}$.

66. $\cot 2x \equiv \frac{1}{2}(\cot x - \tan x)$.

Ans. $-2 \csc^2 2x$.

69. $\frac{x}{\sqrt{1 + x^2}}$.

68. $(2x^3 + 3)^2(1 - 3x^2)^3$.

70. $\sec x + \cos x$.

Ans. $\frac{\sin^3 x}{\cos^2 x}$.

71. $\frac{x^3}{(1 + x^2)^2}$.

72. $2x \sin x + (2 - x^2) \cos x$.

Ans. $x^2 \text{ s. } \tau$.

73. $\frac{2x^2 - 1}{x\sqrt{1 + x^2}}$.

74. $\frac{\sin^n x}{\cos^m x} - \frac{\cos^m x}{\sin^n x}$.

Read
Preface

CHAPTER VI

THEORY OF EQUATIONS, QUADRATURE, AND MAXIMA AND MINIMA

THEORY OF EQUATIONS

320M

63. An expression of the form

$$ax^n + bx^{n-1} + cx^{n-2} + \dots + kx + l, \tag{1}$$

where n is a finite positive integer and the coefficients a, b, c, \dots, k, l do not contain x , is called a **Rational and Integral Algebraic Function** of x of the n th degree; and

$$ax^n + bx^{n-1} + cx^{n-2} + \dots + kx + l = 0 \tag{2}$$

is called the **General Equation** of the n th degree. This is the kind of equation we shall consider in this section.

If we divide the left side of equation (2) by a , the coefficient of x^n , we shall obtain the general equation of the n th degree in the *standard form*,

$$x^n + p_1x^{n-1} + p_2x^{n-2} + \dots + p_{n-1}x + p_n = 0, \tag{3}$$

where $p_1, p_2, \dots, p_{n-1}, p_n$ do not contain x , but are otherwise unrestricted. As will be seen hereafter, some of the properties of equations can be stated more concisely when the equation is in the standard form.

In this section the symbols $f(x), f_1(x), \phi(x), \phi_1(x)$, etc., will be used to denote rational integral functions of x , such as (1) and (3).

Any quantity which substituted for x in $f(x)$ makes $f(x)$ vanish is called a **Root of $f(x)$** ; or a **Root of the Equation $f(x) = 0$** .

If we put $y = f(x)$ and plot the locus of this equation, we shall obtain a curve which is called the **Graph of $f(x)$** . The real roots of $f(x)$ are, therefore, the x intercepts of its graph.

64. A rational integral function of x is continuous, and finite for any finite value of x .

Let $f(x) \equiv p_0x^n + p_1x^{n-1} + p_2x^{n-2} + \dots + p_{n-1}x + p_n$. (1)

Then each term will be finite, provided x is finite; and therefore, as the number of terms is finite, the sum of them all, that is $f(x)$, will be finite for any finite value of x .

Now suppose x receives a small increment h , producing in $f(x)$ the increment $f(x+h) - f(x)$; then

$$f(x+h) - f(x) = p_0[(x+h)^n - x^n] + p_1[(x+h)^{n-1} - x^{n-1}] + \dots + p_{n-1}[(x+h) - x]. \quad (2)$$

Each of the terms in the right member of (2) will become indefinitely small when h is indefinitely small; hence their sum will become indefinitely small. Therefore $f(x+h) - f(x)$ can be made as small as we please by making h sufficiently small. This shows that as x changes from any value a to another value b , $f(x)$ will change gradually and without interruption, *i.e.* without any sudden jump, from $f(a)$ to $f(b)$; so that $f(x)$ must pass at least once through every value intermediate to $f(a)$ and $f(b)$. That is, $f(x)$ is a *continuous function*.

Hence the graph of $f(x)$ is a continuous curve with finite ordinates for finite values of x .

65. To calculate the numerical value of $f(a)$.

Let $f(x) \equiv p_0x^3 + p_1x^2 + p_2x + p_3$. (1)

Then we wish to calculate the numerical value of

$$f(a) = p_0a^3 + p_1a^2 + p_2a + p_3. \quad (2)$$

This result is most easily obtained as follows:

Multiply p_0 by a and add to p_1 , this gives $p_0a + p_1$;

Multiply this by a and add to p_2 , this gives $p_0a^2 + p_1a + p_2$;

Multiply this by a and add to p_3 , this gives $p_0a^3 + p_1a^2 + p_2a + p_3$.

The process may be arranged in the following way:

p_0	p_1	p_2	p_3
	p_0a	$p_0a^2 + p_1a$	$p_0a^3 + p_1a^2 + p_2a$
p_0	$p_0a + p_1$	$p_0a^2 + p_1a + p_2$	$p_0a^3 + p_1a^2 + p_2a + p_3$

We may proceed in the same way, whatever the degree of $f(x)$.

Ex. Find the numerical value of $f(3)$ if

$$f(x) \equiv 2x^4 - 7x^3 + 13x - 16.$$

2	- 7	0	13	- 16
	6	- 3	- 9	12
2	- 1	- 3	4	- 4

$\therefore f(3) = -4.$

This process is called **Synthetic Substitution**.

66. To find the remainder and the quotient when $f(x)$ is divided by $x - a$, where a is any constant.

Divide $f(x)$ by $x - a$ until the remainder no longer contains x .

Let $\phi(x)$ denote the quotient and R the remainder. We then have the identical equation

$$f(x) \equiv \phi(x)(x - a) + R, \quad (1)$$

which must be satisfied when any value whatever is substituted for x . Let $x = a$, then

$$f(a) = \phi(a)(a - a) + R = R; \quad (2)$$

for $\phi(a)(a - a) = 0$, since by § 64 $\phi(a)$ is finite. That is, the remainder is equal to the result obtained by substituting a for x in the given function.

Cor. If a is a root of $f(x)$, then $f(x)$ is divisible by $x - a$.

Conversely, if $f(x)$ is divisible by $x - a$, then a is a root of $f(x)$.

For, if either $f(a) = 0$, or $R = 0$, in (2) the other is also equal to zero, which proves the proposition.

Let $f(x) \equiv p_0x^3 + p_1x^2 + p_2x + p_3$ for example.

By actual division we find

$$\phi(x) = p_0x^2 + (p_0a + p_1)x + (p_0a^2 + p_1a + p_2),$$

and $R = p_0a^3 + p_1a^2 + p_2a + p_3.$

By comparing these expressions with the results found in § 65

we see that R and the coefficients in $\phi(x)$ are the same as the sums obtained by synthetic substitution.

Ex. Find $\phi(x)$ and R when $3x^5 - 2x^4 - 16x^3 - x + 7$ is divided by $(x + 2)$.

$$\begin{array}{r} 3 \quad -2 \quad -16 \quad 0 \quad -1 \quad +7 \quad \zeta \\ \underline{-6 \quad +16 \quad 0 \quad 0 \quad +2} \\ 3 \quad -8 \quad 0 \quad 0 \quad -1 \quad +9 \end{array}$$

Thus $\phi(x) = 3x^4 - 8x^3 - 1$, and $R = 9$.

$$\therefore 3x^5 - 2x^4 - 16x^3 - x + 7 \equiv (x + 2)(3x^4 - 8x^3 - 1) + 9.$$

This process can be applied to any function of any degree, and is a particular case of **Synthetic Division**. (See Todhunter's Algebra, Chap. LVIII.)

67. An equation of the n th degree has n roots, real or imaginary.

Let the equation be

$$f(x) \equiv x^n + p_1x^{n-1} + p_2x^{n-2} + \dots + p_n = 0. \quad (1)$$

Let a_1 be one root* of the equation $f(x) = 0$, then $f(x)$ is divisible by $(x - a_1)$. (§ 66.)

$$\therefore f(x) \equiv (x - a_1)f_1(x), \quad (2)$$

where $f_1(x)$ is an integral function of x of degree $(n - 1)$.

In like manner if a_2 is a root of $f_1(x)$, then

$$f_1(x) \equiv (x - a_2)f_2(x), \quad (3)$$

where $f_2(x)$ is an integral function of x of degree $(n - 2)$.

Proceeding in this way we shall find n factors of the form $(x - a_r)$, and we have finally,

$$f(x) \equiv (x - a_1)(x - a_2)(x - a_3) \dots (x - a_n) = 0. \quad (4)$$

It is now clear that $a_1, a_2, a_3, \dots, a_n$ are roots of the equation $f(x) = 0$; and as no other value of x will make $f(x)$ vanish, the equation can have no other roots.

The factors of $f(x)$ need not all be different from one another; thus we may have

* We here assume the fundamental theorem that every equation has one root, real or imaginary. Proofs of this theorem have been given by Argand, Cauchy, Clifford, and others, but they are too difficult to be included in this book. The student, however, is already familiar with the fact that every equation of the first degree has one root; that every equation of the second degree has two roots, real or imaginary; and it will be shown in § 71 that every equation of an odd degree has one real root.

$$f(x) \equiv (x - a_1)^p (x - a_2)^q (x - a_3)^r \dots, \quad (5)$$

where

$$p + q + r + \dots = n.$$

In this case $f(x)$ has p roots each a_1 , q roots each a_2 , etc., the whole number of roots being

$$p + q + r + \dots = n.$$

Therefore the graph of $f(x)$ will cut the x -axis in n points, which may be real, coincident, or imaginary: and the real roots are its x -intercepts.

Hence the real roots of a function may be found exactly or approximately by constructing its graph.

EXAMPLES

1. Divide $2x^5 - 6x^4 - 5x^2 + 10x + 18$ by $x - 3$.

Find the other roots of the following equations:

2. Two roots of $x^4 - 12x^3 + 49x^2 - 78x + 40 = 0$ are 1 and 5.

3. One root of $x^3 - 16x^2 + 20x + 112 = 0$ is -2 .

4. Two roots of $x^4 + 8x^3 - 22x^2 - 16x + 40 = 0$ are 2 and -10 .

5. Two roots of $x^4 - 12x^3 + 48x^2 - 68x + 15 = 0$ are 5 and 3.

6. Three roots of $6x^5 + 11x^4 - 21x^3 + 7x^2 + 15x - 18 = 0$ are ± 1 and -3 .

Find graphically the exact or approximate roots of

7. $x^3 - 2x^2 - 11x + 12 = 0$.

8. $x^4 - 8x^3 + 14x^2 + 8x - 15 = 0$.

9. $x^4 - 2x^3 - 13x^2 - 14x + 24 = 0$.

10. $x^3 - 8x^2 - 28x + 80 = 0$.

11. $6x^3 - 13x^2 - 21x + 18 = 0$.

12. $8x^3 - 18x^2 - 71x + 60 = 0$.

13. $x^4 - 6x^3 - 5x^2 + 56x - 30 = 0$.

Form the equations whose roots are

14. 1, 3, -5 .

15. $-2, 3, -4, 6$.

16. $\frac{1}{3}, -\frac{7}{2}, \frac{3}{5}$.

17. $\pm 1, \pm 4$.

18. 0, 1, $-4, 5$.

19. $\pm \sqrt{2}, \pm \sqrt{3}$.

20. 0, $-2, \pm \sqrt{-2}$.

21. $3, 5 \pm \sqrt{5}$.

22. $4 \pm \sqrt{3}, -1 \pm \sqrt{6}$.

23. 1, $-2, 3, -4, 5$.

24. 0, $2 \pm \sqrt{-1}, -3 \pm \sqrt{6}$.

25. 0, 0, $\frac{1}{2}, -\frac{3}{5}, 1 \pm \sqrt{2}$.

26. $1 \pm \sqrt{-5}, -2 \pm \sqrt{-7}$.

27. $-3, 2 \pm \sqrt{-3}, -3 \pm \sqrt{-2}$.

68. *Relations between the roots and the coefficients of an equation.*

If there are two roots, a_1 and a_2 , we have (§ 67)

$$\begin{aligned} x^2 + p_1x + p_2 &\equiv (x - a_1)(x - a_2) \\ &\equiv x^2 - (a_1 + a_2)x + a_1a_2. \end{aligned} \quad (1)$$

$$\therefore a_1 + a_2 = -p_1, \quad a_1a_2 = p_2.$$

If there are three roots a_1 , a_2 , and a_3 , we have

$$\begin{aligned} x^3 + p_1x^2 + p_2x + p_3 &\equiv (x - a_1)(x - a_2)(x - a_3) \\ &\equiv x^3 - (a_1 + a_2 + a_3)x^2 + (a_1a_2 + a_2a_3 + a_3a_1)x - a_1a_2a_3. \end{aligned} \quad (2)$$

$$\therefore a_1 + a_2 + a_3 = -p_1, \quad a_1a_2 + a_2a_3 + a_3a_1 = p_2, \quad a_1a_2a_3 = -p_3.$$

In like manner if the equation is of the n th degree and therefore has n roots $a_1, a_2 \dots a_r \dots a_n$, then

$$\begin{aligned} x^n + p_1x^{n-1} + p_2x^{n-2} + \dots + p_r x^{n-r} + \dots + p_n \\ \equiv (x - a_1)(x - a_2) \dots (x - a_r) \dots (x - a_n) \end{aligned} \quad (3)$$

$$\begin{aligned} \equiv x^n - S_1x^{n-1} + S_2x^{n-2} - \dots + (-1)^r S_r x^{n-r} \\ \pm \dots + (-1)^n S_n, \end{aligned} \quad (4)$$

where S_r is the sum of all the products of $a_1, a_2, \dots, a_r \dots a_n$ taken r together.

Equating the coefficients of the same powers of x on the two sides of the identity (4) gives

$$S_1 = -p_1, \quad S_2 = p_2, \quad S_r = (-1)^r p_r,$$

$$S_n = (-1)^n p_n = a_1 a_2 \dots a_r \dots a_n.$$

If $p_n = 0$, one root is zero; if $p_n = p_{n-1} = 0$, two roots are zero; if $p_n = p_{n-1} = \dots = p_{n-r} = 0$, $r + 1$ roots are zero.

EXAMPLES

Find the other roots of the following equations:

1. Two roots of $x^3 + x^2 - 4x - 4 = 0$ are 2 and -1 .
2. Two roots of $x^3 - 4x^2 - 3x + 12 = 0$ are 4 and $\sqrt{3}$.
3. Two roots of $x^3 - 13x + 12 = 0$ are 1 and 3.
4. Three roots of $x^4 - 10x^3 + 35x^2 - 50x + 24 = 0$ are 1, 2, and 3.
5. One root of $x^5 - 6x^4 + 12x^3 = 0$ is $3 - \sqrt{-3}$.
6. Two roots of $6x^4 - 7x^3 - 14x^2 + 15x = 0$ are 1 and $\frac{5}{3}$.
7. Two roots of $4x^5 - 5x^4 + 2x^3 + 6x^2 = 0$ are $1 \pm \sqrt{-1}$.

69. The first term of $f(x)$ can be made to exceed the sum of all the other terms by giving to x a value sufficiently great.

Let $f(x) \equiv p_0x^n + p_1x^{n-1} + p_2x^{n-2} + \dots + p_n$

and let k be the greatest of the coefficients; then

$$\begin{aligned} \frac{p_0x^n}{p_1x^{n-1} + p_2x^{n-2} + \dots + p_n} &> \frac{p_0x^n}{k(x^{n-1} + x^{n-2} + \dots + 1)} \\ &= \frac{p_0x^n(x-1)}{k(x^n-1)} > \frac{p_0x^n(x-1)}{kx^n} = \frac{p_0}{k}(x-1). \end{aligned}$$

Now $\frac{p_0}{k}(x-1)$ can be made as great as we please by sufficiently increasing x , which gives the proposition.

70. An even number, or an odd number, of real roots of $f(x) = 0$ lie between a and b according as $f(a)$ and $f(b)$ have the same sign, or opposite signs.

The two points $A[a, f(a)]$ and $B[b, f(b)]$ are on the same side, or on opposite sides, of the x -axis according as $f(a)$ and $f(b)$ have the same sign, or opposite signs.

Therefore, since the graph of $f(x)$ is a continuous curve (§ 64), in passing from A to B along the graph the x -axis will be crossed an even number, or an odd number, of times according as $f(a)$ and $f(b)$ have the same sign, or opposite signs. This proves the proposition. (An even number includes the case of no roots.)

E.g. If $f(x) \equiv x^3 - 3x + 1$, then $f(1) = -1$ and $f(2) = 3$.

\therefore At least one real root of $x^3 - 3x + 1 = 0$ lies between 1 and 2.

71. An equation of an odd degree has at least one real root.

Let the given equation be

$$f(x) \equiv x^{2n+1} + p_1x^{2n} + p_2x^{2n-1} + \dots + p_{2n+1} = 0.$$

Let a be a positive value of x sufficiently large to make the first term of $f(a)$ greater than the sum of all the other terms (§ 69). Then the sign of $f(a)$ will be the same as the sign of a^{2n+1} , i.e. the same as the sign of a .

Hence if a be sufficiently great, $f(a)$ is positive, $f(0) = p_{2n+1}$, and $f(-a)$ is negative.

Therefore in all cases there is one real root, which is positive or negative according as p_{2n+1} is negative or positive (§ 70).

Hence the graph of a function of an odd degree in the standard form extends to infinity in the first and third quadrants.

72. An equation of an even degree in the standard form with the last term negative has at least two real roots with opposite signs.

Let the given equation be

$$f(x) \equiv x^{2n} + p_1x^{2n-1} + p_2x^{2n-2} + \dots + p_{2n} = 0.$$

If a is taken sufficiently great, $f(a)$ will have the same sign as a^{2n} (§ 69), which is positive for both positive and negative values of a ; that is, $f(a)$ and $f(-a)$ will both be positive, while $f(0) = p_{2n}$, which by hypothesis is negative. Therefore there is at least one real root between 0 and a , and another between 0 and $-a$ (§ 70).

The graph of a function of an even degree in the standard form extends to infinity in the first and second quadrants.

73. To find approximately the real roots of $f(x) = 0$.

Plot the graph of $f(x)$ and thus find the pairs of numbers, usually consecutive integers, between each of which one root lies.

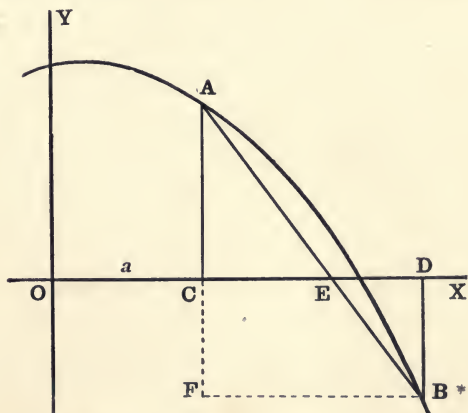

Suppose $f(a) = CA$, a positive number; and $f(a + 1) = DB$, a negative number.

Then there is at least one real root (§ 70) between a and $a + 1$.

Draw the chord AB cutting the x -axis in E ; draw BF parallel to the x -axis meeting AC produced in F .

Then, if there is *only one* root between a and $a + 1$, it is approximately equal to OE ; if the graph were a straight line, it would be *exactly* equal to OE .

Since the triangles ACE and AFB are similar, and $FB = 1$,

$$CE = \frac{FB \cdot CA}{FA} = \frac{CA}{CA + BD} = \frac{f(a)}{f(a) - f(a + 1)}. \quad (1)$$

If we use *numerical* values of $f(a)$ and $f(a + 1)$, we shall then have for all cases

$$OE = a + \frac{f(a)}{f(a) + f(a + 1)}. * \quad (2)$$

Ex. Find the roots of $x^3 - 29x + 42 = 0$.

Here $f(4) = -10$ and $f(5) = 22$. Hence there is a root between 4 and 5.

Substituting in (2) gives $OE = 4 + \frac{10}{10 + 22} = 4.4$.

Then $f(4.4) = -.416$ and $f(4.5) = 2.625$.

Hence the root lies between 4.4 and 4.5.

When the root is greater than OE , as in the diagram and also in this example, it is better to try the figure next greater than that given by the quotient.

The next figure of the root may now be approximated in the same way.

Thus $\frac{f(4.4) \times .1}{f(4.4) + f(4.5)} = \frac{.0416}{3.041} = .01$, since now $FB = .1$.

\therefore The approximate root is 4.41. The exact root is $(3 + \sqrt{2})$.

EXAMPLES

Calculate to two places of decimals the real roots of the equations

1. $x^3 - 3x - 1 = 0$.

6. $x^4 - 12x + 7 = 0$.

2. $x^3 - 7x + 7 = 0$.

7. $x^4 - 5x^3 + 2x^2 - 13x + 55 = 0$.

3. $x^3 + 2x^2 - 3x - 9 = 0$.

8. $x^3 - 3x^2 - 2x + 5 = 0$.

4. $x^3 + 2x^2 - 4x - 43 = 0$.

9. $x^5 - 81x + 40 = 0$.

5. $x^3 - 15x + 21 = 0$.

10. $x^4 - 55x^2 - 30x + 400 = 0$.

74. In any equation with real coefficients imaginary roots occur in pairs.

I. Let $f(x) = 0$ be an equation with real coefficients having r real roots and the other roots imaginary. Then

$$f(x) \equiv (x - a_1)(x - a_2) \cdots (x - a_r)\phi(x) = 0, \quad (\S 67) \quad (1)$$

* The student should compare this method with *Horner's Method of Approximation* found in almost any complete algebra.

where $\phi(x)$ is a function with real coefficients whose roots are all the imaginary roots of $f(x)$, and no others. Hence $\phi(x)$ must be of even degree, and therefore has an even number of roots. Otherwise it would have at least one real root (§ 71).

Therefore (1) has an *even number* of imaginary roots.

II. *If $a + b\sqrt{-1}$ is a root of an equation with real coefficients, then $a - b\sqrt{-1}$ is also a root.*

Let the equation be

$$x^n + p_1x^{n-1} + p_2x^{n-2} + \dots + p_n = 0. \quad (2)$$

Substituting $a + b\sqrt{-1}$ for x in (2), we have

$$(a + b\sqrt{-1})^n + p_1(a + b\sqrt{-1})^{n-1} + p_2(a + b\sqrt{-1})^{n-2} + \dots + p_n = 0. \quad (3)$$

Expanding by the binomial theorem, and collecting together the real and imaginary terms, we shall have a result in the form

$$P + Q\sqrt{-1} = 0. \quad (4)$$

In order that this equation may hold we must have

$$P = Q = 0. \quad (5)$$

Since P and Q are *real*, they contain only even powers of $\sqrt{-1}$, and hence will not be changed by changing the sign of $\sqrt{-1}$. Therefore, when $a - b\sqrt{-1}$ is substituted for x in (2), the result will be $P - Q\sqrt{-1}$.

But from (5) $P - Q\sqrt{-1} = 0$.

$\therefore a - b\sqrt{-1}$ is also a root of (2).

Corresponding to the roots $a \pm b\sqrt{-1}$ of $f(x) = 0$, $f(x)$ will have the real quadratic factor $[(x - a)^2 + b^2]$.

The two quantities $a \pm b\sqrt{-1}$ are called *conjugate imaginary expressions*.

Show that the locus of the equation $y = x^2 + k$ cuts the x -axis in two points which are real and distinct, real and coincident, or imaginary according as k is negative, zero, or positive. Hence illustrate graphically the preceding theorem by showing that, as the absolute term of $f(x)$ is changed, real intersections of its graph

with the x -axis disappear or reappear in pairs; and that the passage from a pair of real distinct roots to a pair of imaginary roots is through a pair of real coincident roots.

EXAMPLES

1. Show that if either $a \pm \sqrt{b}$ is a root of an equation with rational coefficients, the other is also a root.

2. Solve the equation $x^4 - 2x^3 - 22x^2 + 62x - 15 = 0$, having given that one root is $2 + \sqrt{3}$.

3. Solve the equation $2x^3 - 15x^2 + 46x - 42 = 0$, having given that one root is $3 + \sqrt{-5}$.

4. If $\sqrt{a} + \sqrt{b}$ is a root of an equation with rational coefficients, \sqrt{a} and \sqrt{b} not being similar surds, show that $\pm\sqrt{a} \pm \sqrt{b}$ will all four be roots.

5. Form the biquadratic equation with rational coefficients one root of which is $\sqrt{2} + \sqrt{3}$.

6. Show that Ex. 4 holds when either or both a and b are negative.

7. Find the biquadratic equation with rational coefficients one root of which is $\sqrt{2} + \sqrt{-3}$.

8. Solve the equation $2x^6 - 3x^5 + 5x^4 + 6x^3 - 27x + 81 = 0$, having given that one root is $\sqrt{2} + \sqrt{-1}$.

TRANSFORMATION OF EQUATIONS

75. *To find an equation whose roots are those of a given equation with opposite signs.*

If the given equation is $f(x) = 0$, the required equation will be $f(-x) = 0$. For, when $x = a$, $f(x) = f(a)$, and when $x = -a$, $f(-x) = f(a)$; hence, if a is a root of $f(x) = 0$, then $-a$ will be a root of $f(-x) = 0$.

The graph of $f(-x)$ is the reflection of the graph of $f(x)$ in a mirror through the y -axis perpendicular to the plane; *i.e.* the two graphs are symmetrical with respect to the y -axis, which proves the transformation for real roots.

If $f(x) \equiv f(-x)$ [§ 28, (2)], the two graphs will coincide, and the roots of $f(x)$ will occur in symmetric pairs of the form $\pm a$.

The transformed equation is found by simply changing the signs of all the terms of odd degree, or of all the terms of even degree, in the given equation.

76. To find an equation whose roots are those of a given equation, each diminished by the same given quantity.

If we put $x = x' + h$, the origin will be moved to the right a distance equal to h [§ 53, (1)].

Hence the x -intercepts of the graph of $f(x)$, i.e. the real roots of $f(x)$, will each be diminished by h .

Therefore, if $f(x) = 0$ is the given equation, the required equation will be $f(x + h) = 0$. For, when $x = a$, $f(x) = f(a)$, and when $x = a - h$, $f(x + h) = f(a)$; hence, if a is a root of $f(x) = 0$, then $a - h$ is also a root of $f(x + h) = 0$, whether a is real or imaginary.*

The coefficients of the new equation can be found by synthetic substitution as follows:

Ex. Transform the equation $x^4 - 3x^3 - 15x^2 + 49x - 12 = 0$ into another whose roots shall be those of the first each diminished by 2.

Operation	1	- 3	- 15	+ 49	- 12	
		2	- 2	- 34	+ 30	
	1	- 1	- 17	+ 15	+ 18	
		2	2	- 30		
	1	+ 1	- 15	- 15		
		2	+ 6			
	1	+ 3	- 9			
		2				
	1	5				

$\therefore x^4 + 5x^3 - 9x^2 - 15x + 18 = 0$ is the required equation.

[Check this result by substituting directly $x + 2$ for x .]

If we put $x = x' - \frac{p_1}{n}$, where p_1 is the coefficient of x^{n-1} , each root will be diminished by $\left(-\frac{p_1}{n}\right)$, and therefore the sum of the roots will be diminished by $n \left(-\frac{p_1}{n}\right) = -p_1$.

Hence the sum of the roots of the new equation will be zero (§ 68); i.e. the coefficient of the second term will be zero.

Ex. Transform the equation $x^3 + 6x^2 + 4x + 5 = 0$ into another in which the coefficient of x^2 is zero.

* This transformation is used in Horner's Method. See foot-note, p. 90.

Let $x = x' - 2$, since $p_1 = 6$ and $n = 3$; then we obtain

$$\begin{array}{r}
 1 \quad +6 \quad +4 \quad +5 \\
 \quad \quad -2 \quad -8 \quad +8 \\
 \hline
 1 \quad +4 \quad -4 \quad \quad +13 \\
 \quad \quad -2 \quad -4 \quad \quad \quad \\
 \hline
 1 \quad +2 \quad \quad -8 \\
 \quad \quad -2 \quad \quad \quad \\
 \hline
 1 \quad \quad \quad 0
 \end{array}$$

$\therefore x^3 - 8x + 13 = 0$ is the required equation.

77. To find an equation whose roots are the reciprocals of the roots of a given equation.

Let the given equation be

$$p_0 x^n + p_1 x^{n-1} + p_2 x^{n-2} + \dots + p_{n-1} x + p_n = 0. \quad (1)$$

Substituting $\frac{1}{z}$ for x in (1) gives

$$p_0 \left(\frac{1}{z}\right)^n + p_1 \left(\frac{1}{z}\right)^{n-1} + p_2 \left(\frac{1}{z}\right)^{n-2} + \dots + p_{n-1} \left(\frac{1}{z}\right) + p_n = 0, \quad (2)$$

which is the required equation, for (2) is satisfied by the reciprocal of any quantity which satisfies (1).

Multiplying (2) by z^n gives

$$p_n z^n + p_{n-1} z^{n-1} + p_{n-2} z^{n-2} + \dots + p_1 z + p_0 = 0. \quad (3)$$

Therefore the required equation is obtained by merely *reversing the order of the coefficients* of the given equation.

If $p_n = 0$, one root of (1) is zero, and hence the corresponding root of (2) is infinite. Therefore, *as the coefficient of the highest power of x in $f(x)$ approaches the limit zero, one root of $f(x)$ becomes infinite.*

If the coefficients of (1) are the same (or differ only in sign) when read in order backwards as when read in order forwards, the roots of (1) and (3) are the same. That is, the roots of (1) will then occur in pairs of the form a and $\frac{1}{a}$.

An equation in which the reciprocal of any root is also a root is called a **Reciprocal Equation**.

E.g. $6x^3 - 19x^2 + 19x - 6 = 0$ is a reciprocal equation in which the coefficients differ in sign when read in order backwards and forwards; two roots are $\frac{2}{3}$ and $\frac{3}{2}$.

EXAMPLES

Find the equations whose roots are those of the following equations with opposite signs :

1. $x^2 - 4x - 5 = 0.$

2. $x^3 + 6x^2 - 7x - 60 = 0.$

3. $x^3 - 8x^2 - 28x + 80 = 0.$

4. $x^4 - 12x^2 + 12x - 3 = 0.$

Find the equation whose roots are those of

5. $x^3 - 16x^2 + 20x + 112 = 0$, each diminished by 4.

6. $x^4 - 12x^3 + 49x^2 - 78x + 40 = 0$, each diminished by 2.

7. $x^4 - 3x^3 - 6x^2 + 14x + 12 = 0$, each diminished by -2 .

Transform the following equations so as to make the second terms disappear :

8. $x^2 - 4x - 21 = 0.$

9. $x^3 - 6x^2 + 8x - 2 = 0.$

10. $x^4 + 4x^3 - 29x^2 - 156x + 180 = 0.$

11. Find the equation whose roots are those of $x^3 + 6x^2 - 15x + 12 = 0$ each diminished by c , and find what c must be in order that, in the transformed equation, (1) the sum of the roots, and (2) the sum of the products of the roots two together, may be zero.

12. Transform the equation $x^3 + 3x^2 - 9x - 27 = 0$ into another in which the coefficient of x shall be zero.

Find the equation whose roots shall be the reciprocals of the roots of

13. $x^2 - 8x - 9 = 0.$

14. $2x^3 + 3x^2 - 13x - 12 = 0.$

15. $6x^4 - 5x^3 - 30x^2 + 20x + 24 = 0.$

16. Show that a reciprocal equation of an odd degree whose corresponding coefficients have the same sign has one root equal to -1 .

17. Show that a reciprocal equation of an odd degree in which corresponding coefficients have opposite signs has one root equal to $+1$.

18. Show that a reciprocal equation of an even degree in which corresponding coefficients have opposite signs has the two roots ± 1 .

Solve the following equations :

19. $2x^3 - 7x^2 + 7x - 2 = 0.$

20. $6x^3 - 7x^2 - 7x + 6 = 0.$

21. $3x^3 + 5x^2 + 5x + 3 = 0.$

22. $5x^3 - 7x^2 + 7x - 5 = 0.$

23. $2x^4 + 5x^3 - 5x - 2 = 0.$

24. $12x^4 - 25x^3 + 25x - 12 = 0.$

25. $6x^4 - 7x^3 + 7x - 6 = 0.$

26. Solve the equation $2x^4 - 3x^3 - 16x^2 - 3x + 2 = 0$, having given that one root is -2 .

27. Solve the equation $14x^5 - 3x^4 - 34x^3 - 34x^2 - 3x + 14 = 0$, having given that one root is 2.

28. Solve the equation $10x^6 - 21x^5 + 21x - 10 = 0$, having given that one root is 2.

78. Successive Derivatives. If $f(x)$ denote any function of x , its derivative $f'(x)$, (§ 58), will in general be a function of x that can also be differentiated. The result of differentiating $f'(x)$ is called the **Second Derivative** of $f(x)$. If this, again, can be differentiated, the result is called the **Third Derivative**, and so on.

The successive derivatives of $f(x)$ will be denoted by

$$f'(x), f''(x), f'''(x) \dots f^{(n)}(x).$$

Let $f(x) \equiv A_0 + A_1x + A_2x^2 + A_3x^3 + \dots + A_nx^n.$

Then $f'(x) = A_1 + 2 A_2x + 3 A_3x^2 + \dots + nA_nx^{n-1},$ (§ 60)

$$f''(x) = 2 A_2 + 2 \cdot 3 A_3x + \dots + n(n-1) A_nx^{n-2},$$

$$f'''(x) = 1 \cdot 2 \cdot 3 A_3 + \dots + n(n-1)(n-2) A_nx^{n-3},$$

.....

$$f^{(n)}(x) = n(n-1)(n-2) \dots 3 \cdot 2 \cdot 1 A_n = A_n \cdot n!.$$

E.g. if $f(x) \equiv x^4 - 3x^3 - 5x^2 + 2x - 1,$

then $f'(x) = 4x^3 - 9x^2 - 10x + 2,$

$$f'''(x) = 24x - 18,$$

$$f''(x) = 12x^2 - 18x - 10,$$

$$f''''(x) = 24 = 4!.$$

Hence the r th derivative of a rational integral function of the n th degree is itself a rational integral function of degree $(n - r)$, (where r is not greater than n); and the n th derivative is a constant. Therefore the preceding theorems pertaining to a rational integral function $f(x)$ will also hold for its derivatives.

79. The Derivative Curve, and Elbows.

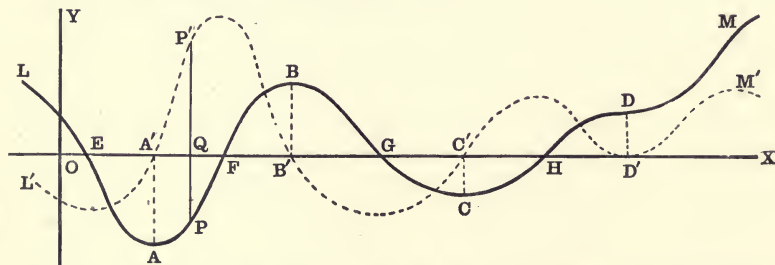

Let the curves LM and $L'M'$ be the loci, respectively, of the equations

$$y = f(x) \tag{1}$$

and $y = f'(x).$ (2)

We will call $L'M'$, the locus of (2), the **Derivative Curve**, (or D. C.), and LM the **Integral Curve**. (See § 81.)

Draw any line parallel to the y -axis meeting the x -axis in Q , and the curves in P and P' .

We will call P and P' **corresponding points**.

Then, if $OQ = a$, we have by § 58

$$QP' = f'(a) = \text{slope of } LM \text{ at } P.$$

Hence the D. C. is a curve such that its *ordinate* at any point is the *slope* of the integral curve at the corresponding point.

Let A, B, C, D be the points on LM where the slope, i.e. $f'(x)$, is zero; then the ordinates of the corresponding points A', B', C', D' on $L'M'$ are zero. Hence A', B', C', D' are the intersections of $L'M'$ with the x -axis. Between A and B the slope of LM is positive, between B and C negative, etc. Therefore, between A' and B' the curve $L'M'$ is above the x -axis between B' and C' below, etc.

It will be convenient to call such points as A, B, C, D , **Elbows** of the curve. Then the abscissas of the elbows of the graph of $f(x)$ are the roots of $f'(x)$, and may therefore be found by plotting the D. C. or by solving the equation $f'(x) = 0$.

Since $f'(x)$ is of degree $(n - 1)$, (§ 78) the graph of $f(x)$ cannot have more than $(n - 1)$ elbows.

If $f(x)$ is of an odd degree, its graph will have an even number of elbows (including *no* elbows), and therefore $f(x)$ will have at least one real root. (Cf. § 71.)

If the roots of $f'(x)$ are all imaginary, the graph of $f(x)$ will have no elbows.

If two roots of $f'(x)$ are equal, its graph will touch the x -axis, as at D' , and the two corresponding elbows of the integral curve will coincide as shown at D . Hence the slope of LM has the same sign on both sides of D . The integral curve therefore changes the direction of its curvature at D , and crosses its own tangent, which it cuts in *three coincident points*. Such a point is called a **Point of Inflection**.

Ex. Find the coordinates of the elbows of the following loci:

1. $y = x^3 - 12x.$

2. $y = 2x^3 - 15x^2 + 24x + 5.$

3. $y = x^3 - 6x^2 + 32.$

4. $y = 3x^4 - 20x^3 + 18x^2 + 108x.$

5. $y = 3x^5 - 20x^3 + 10.$

6. $y = 3x^4 - 8x^3 - 66x^2 + 144x.$

and a is a single root of $f^{(r-1)}(x)$, then a is a double root of $f^{(r-2)}(x)$, a triple root of $f^{(r-3)}(x)$, ... an $(r-1)$ -fold root of $f'(x)$, and an r -fold root of $f(x)$.

This suggests an easy method of finding real multiple roots of an equation, when the roots are all equal except one or two.

$$\begin{aligned} \text{E.g. if} \quad & f(x) \equiv x^5 - 5x^4 + 40x^2 - 80x + 48 = 0, \\ \text{we have} \quad & f'(x) = 5x^4 - 20x^3 + 80x - 80, \\ & f''(x) = 20x^3 - 60x^2 + 80, \\ & f'''(x) = 60x^2 - 120x. \end{aligned}$$

The roots of $60x^2 - 120x = 0$ are 0 and 2.

Since $f'''(2) = f''(2) = f'(2) = f(2) = 0$, 2 is a fourfold root of $f(x) = 0$. Hence all its roots are 2, 2, 2, -3.

Moreover, equations (3) are true whether a is real or imaginary. For suppose $f(x)$ has an r -fold root equal to a , then, whether a is real or imaginary, we have (§ 66 and § 67)

$$f(x) \equiv (x-a)^r \phi(x). \quad (4)$$

In this case the given function $f(x)$ is expressed as the product of two distinct functions of x , viz. $(x-a)^r$ and $\phi(x)$. Hence its derivative may be found by formula (3), § 60.

$$\text{That is, } f'(x) = (x-a)^r \cdot D_x[\phi(x)] + \phi(x) \cdot D_x(x-a)^r. \quad (5)$$

$$\text{But } D_x(x-a)^r = r(x-a)^{r-1} \cdot D_x(x-a) = r(x-a)^{r-1} \cdot [(7), \text{ § 60}] \quad (6)$$

$$\therefore f'(x) = (x-a)^r \phi'(x) + r(x-a)^{r-1} \phi(x) \quad (7)$$

$$= (x-a)^{r-1} [(x-a)\phi'(x) + r\phi(x)] \quad (8)$$

$$= (x-a)^{r-1} \phi_1(x). \quad (9)$$

That is, if a is an r -fold root of $f(x)$, then it is also an $(r-1)$ -fold root of $f'(x)$, whether a is real or imaginary.

In like manner if $f(x)$ also has a q -fold root equal to b , and an s -fold root equal to c , and so on, then

$$f(x) \equiv (x-a)^r (x-b)^q (x-c)^s \dots \phi(x); \quad (10)$$

$$\text{and } f'(x) = (x-a)^{r-1} (x-b)^{q-1} (x-c)^{s-1} \dots \phi_1(x). \quad (11)$$

$$\therefore (x-a)^{r-1} (x-b)^{q-1} (x-c)^{s-1} \dots$$

is the G. C. D of $f(x)$ and $f'(x)$.

Hence the multiple roots of an equation $f(x) = 0$, if there are any, can be detected by finding the G. C. D. of $f(x)$ and $f'(x)$ by the usual algebraic process.

Likewise the common roots of any two functions can be obtained by finding the G. C. D. of the two functions, and then finding the roots of this G. C. D.

Ex. If $f(x) \equiv x^5 + x^4 - 13x^3 - x^2 + 48x - 36 = 0$,
then $f'(x) = 5x^4 + 4x^3 - 39x^2 - 2x + 48$.

The G. C. D. of $f(x)$ and $f'(x)$ will be found to be

$x^2 + x - 6 \equiv (x - 2)(x + 3)$. $\therefore f(x) \equiv (x - 2)^2(x + 3)^2(x - 1) = 0$,
and the roots are 2, 2, -3, -3, 1.

EXAMPLES

Solve the following equations by testing for equal roots:

1. $x^3 + 11x^2 + 24x - 36 = 0$.
2. $x^3 - 2x^2 - 15x + 36 = 0$.
3. $x^4 - 7x^3 + 9x^2 + 27x - 54 = 0$.
4. $x^4 - 11x^3 + 44x^2 - 76x + 48 = 0$.
5. $x^4 - 5x^3 - 9x^2 + 81x - 108 = 0$.
6. $x^5 - 15x^3 + 10x^2 + 60x - 72 = 0$.
7. $x^5 - x^4 - 5x^3 + x^2 + 8x + 4 = 0$.
8. $x^4 - 2x^3 - 11x^2 + 12x + 36 = 0$.
9. $x^5 - 10x^2 + 15x - 6 = 0$.
10. $x^4 - 3x^3 - 6x^2 + 28x - 24 = 0$.
11. $x^5 - 10x^3 + 20x^2 - 15x + 4 = 0$.
12. $x^4 + 10x^3 + 24x^2 - 32x - 128 = 0$.
13. $x^5 + 19x^4 + 130x^3 + 350x^2 + 125x - 625 = 0$.
14. $x^6 - 5x^5 + 5x^4 + 9x^3 - 14x^2 - 4x + 8 = 0$.
15. $x^5 - 2x^4 - 6x^3 + 8x^2 + 9x + 2 = 0$.
16. $x^6 + 7x^5 + 4x^4 - 58x^3 - 115x^2 - 49x - 6 = 0$.
17. $x^5 - 8x^3 + 24x^2 - 28x + 16 = 0$.
18. $x^5 - 6x^3 - 28x^2 - 39x - 36 = 0$.

19. What is the condition that the cubic equation $x^3 + qx + r = 0$ shall have a double root?

20. Show that in any cubic equation with rational coefficients a multiple root must be rational.

QUADRATURE

81. Let $y = f(x)$ and $y = f'(x)$ be the equations of the continuous curves LM and $L'M'$ respectively.

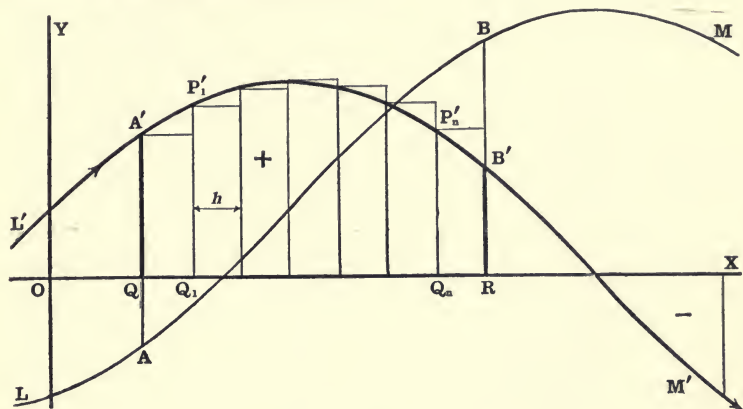

It is required to find the area included between the curve $L'M'$, the x -axis, and the ordinates corresponding to $x = a = OQ$, and $x = b = OR$, where $b > a$. Let K denote the area $QA'B'R$.

Divide the distance QR into $(n + 1)$ equal parts, each equal to $h = \delta x$. Then $(n + 1)h = b - a$. Draw ordinates at the points of division and construct rectangles as shown in the figure.

Let $x_1 = a + h = OQ_1$, $x_2 = a + 2h, \dots, x_n = a + nh = OQ_n$.

Then $QA' = f'(a)$, $Q_1P_1' = f'(x_1), \dots, Q_nP_n' = f'(x_n)$,

and the sum of the areas of the $(n + 1)$ rectangles is

$$hf'(a) + hf'(x_1) + hf'(x_2) + \dots + hf'(x_n).$$

$$\therefore K = \lim_{n \rightarrow \infty} [h\{f'(a) + f'(x_1) + f'(x_2) + \dots + f'(x_n)\}]. \quad (1)$$

Now
$$f'(x) = \lim_{h \rightarrow 0} \frac{f(x+h) - f(x)}{h}. \quad (\S 58.) \quad (2)$$

Let
$$f'(x) + \rho = \frac{f(x+h) - f(x)}{h}, \quad (3)$$

where ρ is a quantity that approaches zero when $h \rightarrow 0$.

Then
$$hf'(x) + h\rho = f(x+h) - f(x). \quad (4)$$

Hence we may put $hf'(a) + h\rho_0 = f(x_1) - f(a)$,

$$hf'(x_1) + h\rho_1 = f(x_2) - f(x_1),$$

$$hf'(x_2) + h\rho_2 = f(x_3) - f(x_2),$$

.....

$$hf'(x_{n-1}) + h\rho_{n-1} = f(x_n) - f(x_{n-1}),$$

$$hf'(x_n) + h\rho_n = f(b) - f(x_n).$$

From these equations we have by addition

$$\Sigma hf'(x) + \Sigma h\rho = f(b) - f(a). \quad (5)$$

The second member of (5) is independent of n , $\Sigma hf'(x)$ represents the *sum* of the areas of the $(n+1)$ rectangles however great their number, and $\Sigma h\rho \doteq 0$ when $h \doteq 0$, *i.e.* when n becomes infinite. For $\Sigma h\rho < (n+1)h\rho' = (b-a)\rho'$, where ρ' is the greatest of the quantities $\rho_1, \rho_2 \dots \rho_n$, and $\rho' \doteq 0$ when $h \doteq 0$.

$$\therefore K = \lim_{n=\infty} \Sigma f'(x)\delta x = f(b) - f(a) = RB - QA. \quad (6)$$

The notation used to express this is

$$K = \int_a^b f'(x) dx = f(b) - f(a), \quad (7)$$

where the symbol \int stands for "the limit of the sum," in this case, *the limit of the sum of an infinite number of infinitesimal rectangles.*

Therefore, in order to find the required area, we must first obtain a function *which when differentiated will give $f'(x)$* ; then substitute in this new function $f(x)$ the abscissas of the bounding ordinates and take the difference of the results. Hence equation (7) may be written

$$K = \int_a^b f'(x) dx = \left[f(x) \right]_a^b = f(b) - f(a). \quad (8)$$

In applying the formula we must first find $f(x)$ from $f'(x)$, *i.e.* we must *reverse* the operation of differentiation. In this sense the symbol \int denotes an operation which is the *inverse of differentiation.*

This inverse process is called **Integration.**

If then the symbol D be used to denote differentiation, the two symbols \int and D neutralize each other, *i.e.* $\int Df(x) = f(x)$.

E.g. if $Df(x) = f'(x)dx = (4x^3 - 3x^2 + 4x - 6)dx$,

then $\int Df(x) = \int f'(x)dx = f(x) = x^4 - x^3 + 2x^2 - 6x + c$.

Hence, to *integrate* an integral function of x , increase the exponent of each power of x by unity and divide the coefficient by the increased exponent.

Thus, $\int x^n dx = \frac{x^{n+1}}{n+1}$, provided $n \neq -1$.

If $f'(x)$ is the derivative of $f(x)$, then $f(x)$ is called the **Integral** of $f'(x)$. The curve LM may be called the *Integral Curve* with respect to $L'M'$. Then we may say that the area bounded by the D. C., the x -axis, and two ordinates is numerically equal to the difference of the two corresponding ordinates of the I. C.

If $L'M'$ lies below the x -axis between A' and B' , the slope of LM between A and B will be negative (§ 79). Hence $RB < QA$, *i.e.* $f(b) < f(a)$, and the *area is negative*. The rectangles will then lie above the curve.

Therefore the area will be *positive* or *negative* according as it lies to the *right* or *left* of the curve *viewed in the direction of x increasing*. If $L'M'$ cuts the x -axis between A' and B' , the formula gives the excess (positive or negative) of the area which lies to the right over that which lies to the left.

Ex. 1. Find the area of the segment of the parabola $y^2 = 4ax$ cut off by the double ordinate through $P(x', y')$.

Here $y = 2\sqrt{ax}^{\frac{1}{2}} = f'(x)$.

\therefore Area

$$ONP = \int_0^{x'} 2\sqrt{ax}^{\frac{1}{2}} dx = 2\sqrt{a} \int_0^{x'} x^{\frac{1}{2}} dx$$

$$= 2\sqrt{a} \left[\frac{2}{3} x^{\frac{3}{2}} \right]_0^{x'} = 2\sqrt{a} \cdot \frac{2}{3} x'^{\frac{3}{2}}$$

$$= \frac{2}{3} x' \cdot 2\sqrt{ax'}^{\frac{1}{2}} = \frac{2}{3} x'y'$$

$$= \frac{2}{3} \text{rectangle } OBPN.$$

\therefore Area $OPQ = \frac{2}{3}$ rectangle $ABPQ$.

\therefore Area between AB and the curve is equal to $\frac{1}{3} ABPQ$.

That is, the parabola trisects the rectangle.

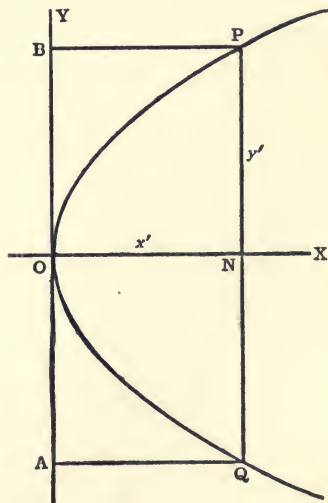

Ex. 2. The curve $y = x^3 - 3x^2 + 2x$ cuts the x -axis in the points $(0, 0)$, $B(1, 0)$, $D(2, 0)$.

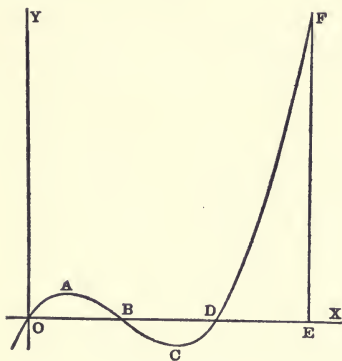

We now have $f'(x) = x^3 - 3x^2 + 2x$.

$$\therefore OAB = \int_0^1 f'(x) dx$$

$$= \int_0^1 (x^3 - 3x^2 + 2x) dx$$

$$= \left[\frac{x^4}{4} - x^3 + x^2 + c \right]_0^1 = \frac{1}{4}.$$

$$BCD = \left[\frac{x^4}{4} - x^3 + x^2 + c \right]_1^2$$

$$= (4 - 8 + 4 + c) - \left(\frac{1}{4} + c \right) = -\frac{1}{4}.$$

$$DEF = \left[\frac{x^4}{4} - x^3 + x^2 + c \right]_2^3$$

i.e. $DEF = \left(\frac{81}{4} - 27 + 9 + c \right) - (4 - 8 + 4 + c) = 2\frac{1}{4}.$

EXAMPLES

1. Find the area included between the curve $y = x^3 - 9x^2 + 23x - 15$, the x -axis, and the lines $x = 1$, $x = 3$; also $x = 3$, $x = 5$; $x = 1$, $x = 5$.

2. Find the area included between the curve $y = x^2 - 2x - 8$, the x -axis, and the lines $x = -2$, $x = 4$; also between the curve $y = x^2 - 2x + 1$ and the same lines.

Find the area between the x -axis and the curve

3. $y = x^3 - 3x^2 - 9x + 27$.

4. $y = x^3 + ax^2$.

Ans. $\frac{a^4}{12}$.

5. $y = x^4 - 4x^3 - 2x^2 + 12x + 9$.

Find the area between the curves

6. $y^2 = 4ax$ and $x^2 = 4ay$.

9. $y^m = x^n$ and $y^n = x^m$.

Ans. $\frac{m-n}{m+n}$.

7. $y^2 = 4x$ and $y^2 = x^3$.

10. $y = x^3 - x$ and $y = x$.

8. $y^3 = x^2$ and $y^2 = x^3$.

11. $y = x^3 - x$ and $y^2 = x\sqrt{2}$.

12. $y^2 = 4ax$ and $y = 2x - 4a$.

13. $x^2y = a^3$, $x = b$, $x = c$, and $y = 0$.

Ans. $a^3 \left(\frac{b-c}{bc} \right)$.

14. $y = x^2 - 5x + 4$ and $x + y = 4$.

Ans. $10\frac{2}{3}$.

15. $y = x^3$ and $y^3 = x$.

16. Show that the area included between the curve $y = Ax^n$, the x -axis and the line $x = a$ is $\frac{ab}{n+1}$, where b is the ordinate corresponding to $x = a$.

Show that the parabola is a particular case.

MAXIMA AND MINIMA

82. Let the curves ML , $L'M'$, and $L''M''$ be the loci, respectively, of the equations

$$(1) y = f(x), \quad (2) y = f'(x), \quad (3) y = f''(x).$$

It is assumed in this investigation that the functions $f(x)$, $f'(x)$, $f''(x)$ are finite and continuous for all finite values of x .

Then $L''M''$ is the *Second Derivative Curve*.

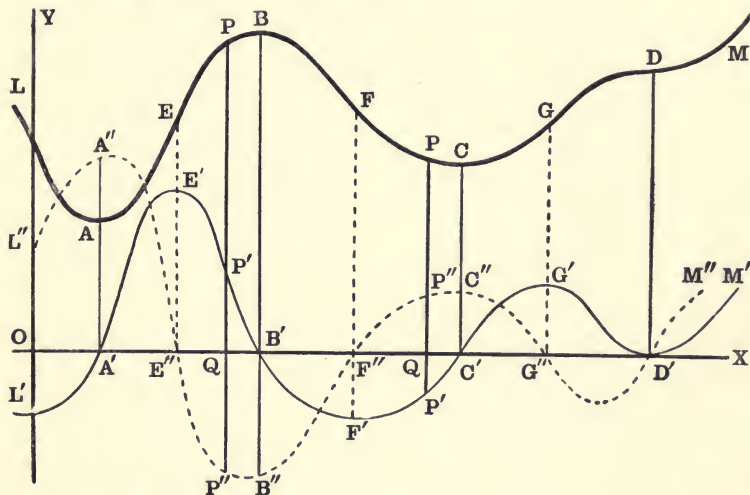

Since $f''(x)$ is the first derivative of $f'(x)$, the ordinate of $L''M''$ at any point represents the slope of $L'M'$ at the corresponding point; and the intersections E'' , F'' , G'' of $L''M''$ with the x -axis correspond to the elbows E' , F' , G' of $L'M'$ (§ 79).

Let the line $x = a$ meet the curves in the corresponding points P , P' , P'' , and the x -axis in Q .

$$\text{Then } QP = f(a), \quad QP' = f'(a), \quad QP'' = f''(a).$$

That is, QP' is the slope of LM at P , and QP'' is the slope of $L'M'$ at P' .

Suppose the point P to move along the curve LM toward the right. As P approaches the elbow B , the ordinate QB increases; but as P passes through B , the ordinate ceases to increase and begins to

decrease. At such a point the ordinate, *i.e.* $f(x)$, is said to have a **Maximum Value**, or to be a **Maximum**. In like manner as P approaches the elbow A , or C , the ordinate QP decreases; but as P passes through A , or C , the ordinate *ceases to decrease and begins to increase.* At such points QP , *i.e.* $f(x)$, is said to have a **Minimum Value**, or to be a **Minimum**.

That is, a function, $f(x)$, is said to have a *maximum value* when $x = a$, if $f(a) > f(a \pm h)$; and a *minimum value*, if $f(a) < f(a \pm h)$, for *very small* values of h .

Since in these definitions the comparison is made between values of $f(x)$ in the immediate vicinity only of A, B, C , a maximum is not necessarily the *greatest*, nor a minimum the *least*, of *all* the values of the function.

Moreover, since maximum and minimum ordinates occur only at the elbows of a curve where the tangent is parallel to the x -axis, a *necessary* but not a *sufficient* condition for a maximum or minimum value of $f(x)$ is $f'(x) = 0$ (§ 79).

Suppose a tangent to be drawn to LM at any elbow, *i.e.* at any point where $f'(x) = 0$. Then the curve will lie below or above this tangent line for a short distance on both sides of the elbow, according as the ordinate of the elbow is a maximum or a minimum. If the curve crosses this tangent, as at D , the ordinate is neither a maximum nor a minimum.

Hence, as P passes (toward the right) through an elbow, as B , whose ordinate is a maximum, the slope of LM , *i.e.* $f'(x)$, changes from *positive* to *negative*; and as P passes through an elbow, such as A or C , whose ordinate is a minimum $f'(x)$ changes from *negative* to *positive*.

Therefore, the necessary and sufficient conditions that $f(x)$ shall be a maximum or a minimum when $x = a$ are as follows:

$$\left. \begin{array}{l} \text{For max., } f'(a) = 0; f'(a - h), \text{ positive; } f'(a + h), \text{ negative.} \\ \text{For min., } f'(a) = 0; f'(a - h), \text{ negative; } f'(a + h), \text{ positive.} \end{array} \right\} \quad (4)$$

If $f'(a + h)$ and $f'(a - h)$ have the *same* sign, $f(a)$ is neither a maximum nor a minimum value of $f(x)$.

Now suppose, as is usually the case, that a is a single root of $f'(x) = 0$, so that $f''(a) \neq 0$. (§ 80.)

Then if QP passes through a maximum value, as $B'B$, when $x = a$, the slope of LM changes from $+$ to $-$. Hence the corresponding point P' crosses the x -axis from *above downwards*, and therefore the slope of $L'M'$ at B' is negative, *i.e.*

$$B'B'' = f''(a) \text{ is negative.}$$

If QP passes through a minimum value, as $C'C$, the slope of LM changes from $-$ to $+$. Hence P' crosses the x -axis from *below upwards*, and therefore the slope of $L'M'$ at C' is positive, *i.e.*

$$C'C'' = f''(a) \text{ is positive.}$$

Therefore, if $f''(a) \neq 0$, the necessary and sufficient conditions that $f(a)$ shall be a maximum or a minimum value of $f(x)$ are:

$$\left. \begin{array}{l} \text{For a maximum, } f'(a) = 0; f''(a), \text{ negative.} \\ \text{For a minimum, } f'(a) = 0; f''(a), \text{ positive.} \end{array} \right\} \quad (5)$$

If a is an r -fold root of $f'(x) = 0$, then $f''(a) = 0$ when $r > 1$ (§ 80) and the conditions (5) fail to disclose the nature of the corresponding ordinate.

If r is an odd number, the curve $L'M'$ will cut the x -axis in an odd number of coincident points, and hence will cross the x -axis at the point $(a, 0)$. Therefore the sign of $f'(x)$ will change from $+$ to $-$ for a maximum, and from $-$ to $+$ for a minimum. In this case we must use conditions (4) to determine the nature of $f(a)$.

If r is an even number, $L'M'$ will not cross the x -axis at the point $(a, 0)$, as at D' . Hence $f'(x)$ will not change sign, and therefore $f(a)$ is neither a maximum nor a minimum.

The maximum and minimum ordinates of $L'M'$ can be determined in the same manner. The points E, F, G, D on LM corresponding to the maximum and minimum ordinates of $L'M'$ are therefore, respectively, the points of maximum and minimum slope of LM . At the points where the slope of a curve ceases to increase and begins to decrease, or *vice versa*, the curve changes the direction of its curvature. Therefore E, F, G, D are the points of inflection of LM (§ 79).

Hence the position of the points of inflection of a curve are obtained by finding the position of the maximum and minimum ordinates of the $D. C.$

83. ILLUSTRATIVE EXAMPLES.

EX. 1. The curves $y = \sin x$ and $y = \cos x$ are good examples of the relations and principles explained in § 81 and § 82.

Let $f(x) \equiv \sin x$.

$$\text{Then } f'(x) = \lim_{h \rightarrow 0} \frac{\sin(x+h) - \sin x}{h} = \lim_{h \rightarrow 0} \left[\cos\left(x + \frac{1}{2}h\right) \frac{\sin \frac{1}{2}h}{\frac{1}{2}h} \right] \quad (1)$$

$$= \cos x. \quad (\text{Ex. 13, p. 71.}) \quad (2)$$

Similarly it has been shown that $D_x(\cos x) = -\sin x$. (p. 75.)

Let $y = f(x) = \sin x$, equation of LM ,

$y = f'(x) = \cos x$, equation of $L'M'$,

and $y = f''(x) = -\sin x$, equation of $L''M''$.

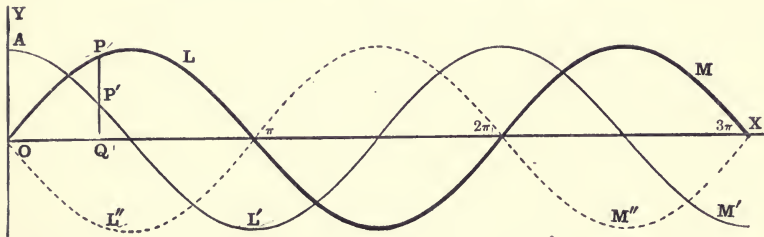

Then $f'(x) = \cos x = 0$, when $x = \frac{1}{2}\pi, \frac{3}{2}\pi, \frac{5}{2}\pi$, etc.,

and $f''(\frac{1}{2}\pi) = -\sin \frac{1}{2}\pi = -1$. $\therefore \sin \frac{1}{2}\pi = 1$ is a max.

$f''(\frac{3}{2}\pi) = -\sin \frac{3}{2}\pi = 1$. $\therefore \sin \frac{3}{2}\pi = -1$ is a min., etc.

Also $f''(x) = -\sin x = 0$, when $x = 0, \pi, 2\pi, 3\pi$, etc.

These values of x make $\cos x$ alternately a maximum and a minimum, and hence give the points of inflection of LM . That is, the sine curve changes the direction of its curvature as it crosses the x -axis.

Let $x = OQ$ be any line parallel to the y -axis.

Then $f'(x) = \cos x = QP'$ = slope of LM at P .

Moreover, by § 81 we have

$$\text{Area } OAP'Q = \int_0^x f'(x)dx = \int_0^x \cos x dx = \left[\sin x \right]_0^x = \sin x = QP. \quad (3)$$

That is, the ordinate of any point of the cosine curve is equal to the slope of the sine curve at the corresponding point; and the ordinate of the sine curve is equal to the area bounded by the ordinate, the cosine curve, and the axes of coordinates.

Ex. 2. Find the maximum and minimum values of the function

$$f(x) \equiv x^4 - 4x^3 - 2x^2 + 12x + 4.$$

$$\text{Here } f'(x) = 4x^3 - 12x^2 - 4x + 12$$

$$\text{and } f''(x) = 12x^2 - 24x - 4.$$

The roots of $f'(x) = 0$

are $-1, 1, 3.$

$$f''(-1) = 32.$$

$\therefore f(-1) = -5$ is a minimum.

$$f''(1) = -16.$$

$\therefore f(1) = -11$ is a maximum.

$$f''(3) = 32.$$

$\therefore f(3) = -5$ is a minimum.

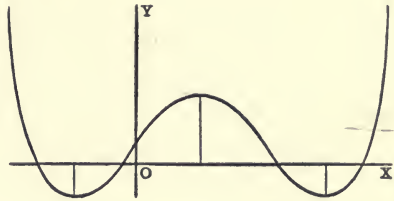

The roots of $f''(x) = 0$ are $1 \pm \frac{2}{3}\sqrt{3}$, which are the distances of the points of inflection from the y -axis.

In the solution of problems in maxima and minima, we must first obtain an algebraic expression, $f(x)$, for the quantity whose maximum or minimum is required. We may then proceed as in the preceding examples.

Ex. 3. Find the maximum rectangle that can be inscribed in a given triangle.

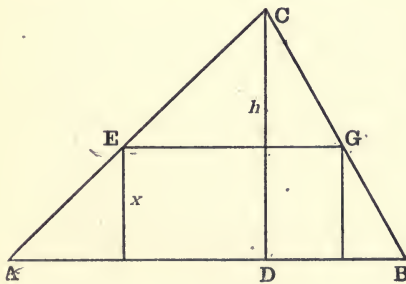

Let b = the base of the given triangle ABC , h the altitude, and x the altitude of the inscribed rectangle. Then from similar triangles,

$$EG : b = (h - x) : h.$$

$$\therefore EG = \frac{b}{h}(h - x).$$

Then $\frac{b}{h}(hx - x^2)$ is the area of the rectangle, which is to be made a maximum. Any value of x that

will make $(hx - x^2)$ a maximum will also make $\frac{b}{h}(hx - x^2)$ a maximum. Hence we may put

$$f(x) \equiv hx - x^2.$$

Then $f'(x) = h - 2x = 0$ when $x = \frac{1}{2}h.$

Also $f''(x) = -2.$

$$\therefore f\left(\frac{1}{2}h\right) = \frac{1}{4}h^2 \text{ is a maximum.}$$

Therefore the altitude of the maximum inscribed rectangle is one-half the altitude of the triangle.

Ex. 4. Find the area of the largest rectangle which can be inscribed in the ellipse

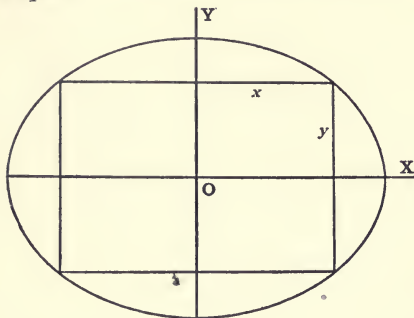

$$\frac{x^2}{a^2} + \frac{y^2}{b^2} = 1. \quad (1)$$

Let K denote the area of the rectangle. Then

$$K = 2x \cdot 2y = \frac{4b}{a} \sqrt{a^2x^2 - x^4} \quad (2)$$

is the function of x which is to be a maximum.

Any value of x which will make $a^2x^2 - x^4$ a maximum, or a minimum, will also make K a maximum, or a minimum.

Therefore, let $f(x) \equiv a^2x^2 - x^4$.

Then $f'(x) = 2a^2x - 4x^3 = 0$ when $x = 0$, or $\pm \frac{1}{2}a\sqrt{2}$,

and $f''(x) = 2a^2 - 12x^2 = -4a^2$ when $x = \frac{1}{2}a\sqrt{2}$.

$\therefore x = \frac{1}{2}a\sqrt{2}$ will make K a maximum.

Therefore $K = 2ab$ is the area of the maximum rectangle, which is half the rectangle whose sides are the axes of the ellipse.

Ex. 5. Find the dimensions of a cone of revolution which shall have the greatest volume with a given surface.

Let x = the radius of the base, y = the slant height, V = the volume, and S = the total surface.

Then $S = \pi x^2 + \pi xy$; whence $y = \frac{S}{\pi x} - x$,

and $(\text{Altitude})^2 = y^2 - x^2 = \frac{S^2}{\pi^2 x^2} - \frac{2S}{\pi}$.

$$\therefore V = \frac{\pi x^2}{3} \sqrt{\frac{S^2}{\pi^2 x^2} - \frac{2S}{\pi}} = \frac{\sqrt{S^2 x^2 - 2\pi S x^4}}{3}$$

Let $f(x) \equiv Sx^2 - 2\pi x^4$.

Then $f'(x) = 2Sx - 8\pi x^3 = 0$ when $x = 0$, or $\pm \frac{1}{2}\sqrt{\frac{S}{\pi}}$,

and $f''(x) = 2S - 24\pi x^2 = -4S$ when $x = \frac{1}{2}\sqrt{\frac{S}{\pi}}$.

$\therefore V$ is a max. when $x = \frac{1}{2}\sqrt{\frac{S}{\pi}}$, and $y = \frac{3}{2}\sqrt{\frac{S}{\pi}}$.

That is, if the surface is constant, the volume of the cone is a maximum when the slant height is three times the radius of the base.

EXAMPLES

Find the maximum and minimum ordinates and the points of inflection (points of maximum or minimum slope) of the curves

1. $y = x^3 - 3x^2 + 4.$

2. $y = x^3 - 9x^2 + 15x - 3.$

3. $y = x^3 - 3x^2 + 6x + 7.$

4. $y = x^3 - 9x^2 + 24x + 16.$

5. Find the sides of the maximum rectangle which can be inscribed in a circle ; in a semicircle.

6. Find the sides of the maximum rectangle which can be inscribed in a semi-ellipse.

7. Find the altitude of the maximum rectangle which can be inscribed in a segment of a parabola, the base of the segment being perpendicular to the axis of the parabola.

8. What is the least square that can be inscribed in a given square ?

9. Find the altitude of a cylinder inscribed in a cone when the volume of the cylinder is a maximum.

10. What are the most economical proportions for a cylindrical tin can ? That is, what should be the ratio of the height to the radius of the base that the capacity shall be a maximum for a given amount of tin ?

11. What are the most economical proportions for a cylindrical tin cup ?

12. What are the most economical proportions for an open cylindrical water tank made of iron plates, if the cost of the sides per square foot is two-thirds of the cost of the bottom per square foot ?

13. An open box is to be made from a sheet of pasteboard 12 inches square by cutting equal squares from the four corners and bending up the sides. What are the dimensions of the largest box that can be made ?

14. If a rectangular piece of pasteboard, whose sides are a and b , have a square cut from each corner, find the side of the square so that the remainder may form a box of maximum capacity.

15. A person being in a boat 3 miles from the nearest point of the shore, wishes to reach in the shortest possible time a place 5 miles from that point along the shore ; supposing he can walk 5 miles an hour, but can row only at the rate of 4 miles an hour, required the place where he must land.

16. The cost per hour of driving a steamer through still water varies as the cube of its speed. At what rate should it be run to make a trip against a four-mile current most economically ?

17. Find the altitude of the greatest cylinder that can be cut out of a given sphere.

18. Find the altitude of the maximum isosceles triangle that can be inscribed in a given circle.

19. Find the altitude of the greatest cone that can be inscribed in a given sphere.

20. Find the altitude of a cone inscribed in a sphere which shall make the convex surface of the cone a maximum.

21. If the slant height of a cone is constant, what is the ratio of the radius of the base to the altitude when the volume of the cone is a maximum?

22. Find the dimensions of a cone with a given convex surface and a maximum volume.

23. Find the altitude of the least cone that can be circumscribed about a given sphere.

24. Find the altitude of the maximum cylinder that can be inscribed in a given paraboloid.

25. What is the diameter of a ball which, being let fall into a conical glass of water, shall expel the most water possible from the glass; the depth of the glass being 6 inches and its diameter at the top 5 inches? *Ans.* $4\frac{1}{4}$ in.

26. The sides of a rectangle are a and b . Show that the greatest rectangle that can be drawn so as to have its sides passing through the corners of the given rectangle is a square whose side is $\frac{a+b}{\sqrt{2}}$.

27. The strength of a beam of rectangular cross-section, if supported at the ends and loaded in the middle, varies as the product of the breadth of the cross-section by the square of its depth. Find the dimensions of the cross-section of the strongest beam that can be cut from a log 18 inches in diameter.

28. A Norman window consists of a rectangle surmounted by a semicircle. If the perimeter of the window is given, show that the quantity of light admitted is a maximum when the radius of the semicircle is equal to the height of the rectangle.

29. What are the most economical proportions for a cylindrical tin can, and a cylindrical tin cup, if the top and bottom are cut out of regular hexagons, and allowance is made for waste? *Ans.* $\pi h = 4r\sqrt{3}$, and $\pi h = 2r\sqrt{3}$.

30. Show that the curve $(x^2 + a^2)y = a^2x$ has three points of inflection, and that they all lie on the line $x = 4y$.

From

CHAPTER VII

CONIC SECTIONS

84. The general equation of the first degree and also some special cases of the equation of the second degree have been considered in Chapters II and III. We now proceed to the general equation of the second degree, and the standard forms to which it can be transformed. It will presently be shown that the locus of such an equation is always a curve that can be obtained by making a plane section of a right circular cone. For this reason the locus is called a **Conic Section**.*

85. *The Fundamental Property of a Plane Section of a Right Circular Cone, or a Conic Section.*

Let VO be the axis of a right circular cone, and APB any section made by a plane not passing through V .

Inscribe a sphere in the cone tangent to the plane of the section at F ; then the line of contact HRK of the sphere and cone is a circle with centre C in VO , whose plane is perpendicular to VO and meets the plane of the section APB in the line ES .

Pass the plane VMN through VO perpendicular to the plane APB , meeting it in the line AB , meeting the plane HRK in HK , and the line ES in D ; then the plane VMN is also perpendicular to the plane HRK , and therefore perpendicular to ES .

* After studying the straight line and the circle, the old Greek mathematicians turned their attention to the conic sections, and by investigating them as sections of a cone soon discovered many of their characteristic properties. The most important of these discoveries were probably made by Archimedes and Apollonius, as the latter wrote a treatise on conic sections about 200 B.C.

These curves are worthy of careful study, not only on account of their historic interest, but also on account of their importance in the physical sciences and their frequent occurrence in the experiences of everyday life. For example, the orbit of a heavenly body is a conic section. For this reason they were thoroughly studied by the astronomer, Kepler, about 1600 A.D. The path of a projectile is a parabola. The graphical representations of the law of falling bodies, the pressure-volume law of gases, the law of moments in uniformly loaded beams, are all conic sections. The bounding line of a beam of uniform strength, the oblique section of a stove-pipe, the shadow of a circle, the apparent line dividing the dark and light parts of the moon, etc., are conic sections. The reflectors in head-lights and search-lights are parabolic.

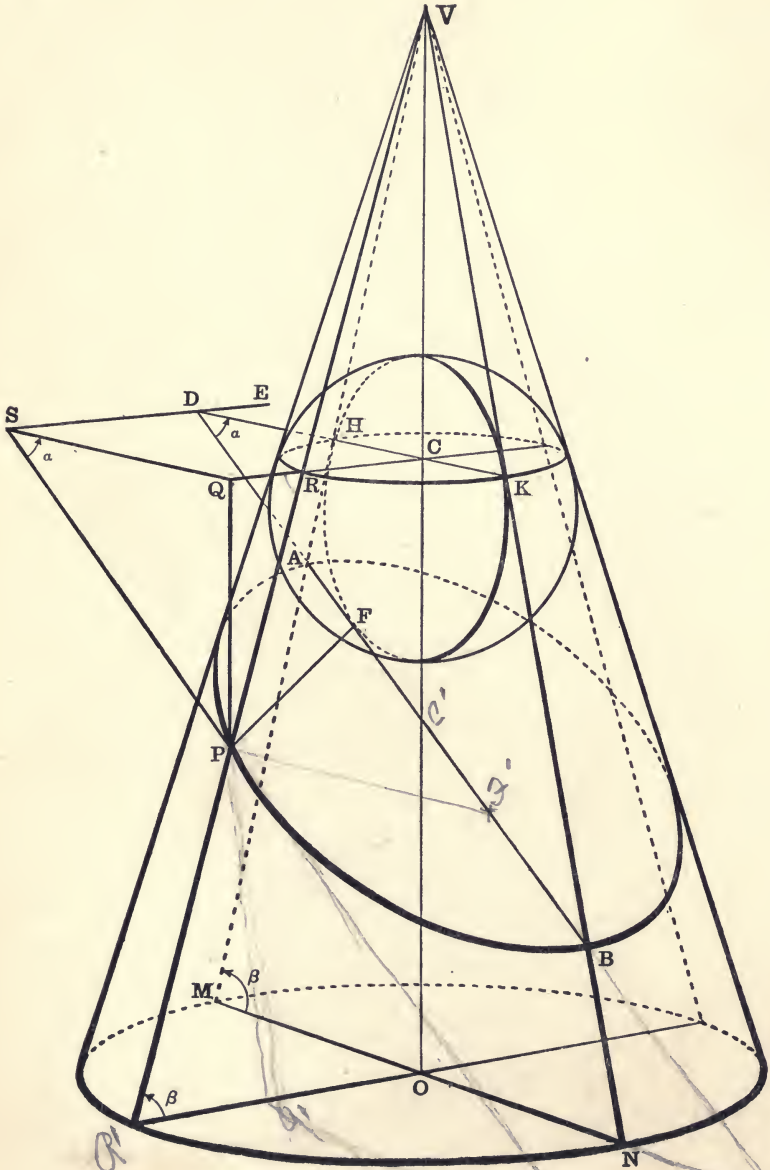

Let P be any point on the section.

Draw PF , and the element PV which will be tangent to the sphere at R .

Through P draw a line perpendicular to the plane HKR , which will meet CR produced in Q ; and through PQ pass a plane perpendicular to ES meeting it in S .

Let $\beta = \angle PRQ = \angle AHD$, the complement of the semi-vertical angle of the cone. Let $\alpha = \angle ADH = \angle PSQ$. Then, since tangents from an external point to a sphere are equal, $PF = PR$.

From the right triangles PQR and PSQ we get

$$PQ = PR \sin \beta = PS \sin \alpha.$$

$$\therefore \frac{PF}{PS} = \frac{\sin \alpha}{\sin \beta}. \quad \frac{PF}{\sin \alpha} = \frac{PS}{\sin \beta} \quad (1)$$

So long as we consider any particular section, the point F and the line ES are fixed, α is constant, and therefore the ratio of PF to PS is constant.

Equation (1) expresses the *Fundamental Property of a Conic Section*, which is used as the defining property. Moreover, all curves which have this property are plane sections of some cone; for all possible curves satisfying this condition are gotten by giving this constant ratio all possible values, and also letting the distance, FD , from the fixed point to the fixed line have all possible values. We can do this with a conic section. For any particular value of β , i.e. for any particular cone, the ratio can vary from zero (when $\alpha = 0$) to $\csc \beta$ (when $\alpha = \frac{1}{2} \pi$). For any particular value of α the ratio can vary from $\sin \alpha$ (when $\beta = \frac{1}{2} \pi$) to ∞ (when $\beta = 0$). Thus the ratio can have any value from 0 to ∞ . Also the distance of F from ES , depending as it does upon the size of the inscribed sphere, for any particular cone and any particular value of α can vary from zero to ∞ . Therefore the property expressed by (1) is indeed a defining property of a conic section, that is:

*A Conic Section, or a Conic, is the locus of a point which moves in a plane so that its distance from a fixed point in the plane is in a constant ratio to its distance from a fixed line in the plane.**

* This is generally known as Boscovich's definition of a conic section, but, in the article on Analytic Geometry in the Encyclopedia Britannica, ninth edition, Cayley calls it the definition of Apollonius.

The fixed point F is called the **Focus**; the fixed line ES is called the **Directrix**; the constant ratio is called the **Eccentricity**, and is denoted by the letter e ; the line BFD , through the focus perpendicular to the directrix, is called the **Principal Axis** of the conic.

86. Classification of the Conic Sections.

Using e to denote the eccentricity, we have, by (1) of § 85,

$$\frac{PF}{PS} = \frac{\sin \alpha}{\sin \beta} = e. \quad (1)$$

When $\alpha < \beta$, $e < 1$; the plane of the section meets all the elements of the cone on the same side of the vertex; the section is a closed curve as shown in the figure § 85, and is called an **Ellipse**.

When $\alpha = 0$, $e = 0$; the plane of the section is perpendicular to the axis of the cone, VO , and the section is a **Circle**. Hence a circle is a particular case of the ellipse.

When $\alpha = \beta$, $e = 1$; the line AB (§ 85) is then parallel to VN , and the point B moves off to an infinite distance; the section consists of a single infinite branch, and is called a **Parabola**.

When $\alpha > \beta$, $e > 1$, and the plane APB (§ 85) meets NV produced on the other sheet of the conical surface; the section is then composed of two infinite branches, one lying on each sheet of the cone, and is called a **Hyperbola**.

Thus the parabola is the limiting case of both the ellipse and the hyperbola.

Let the plane of the section pass through the vertex of the cone.

Then if $e < 1$, the section is a point ellipse or a point circle.

If $e = 1$, the plane is tangent to the cone, and the parabola reduces to two coincident straight lines.

If $e > 1$, the hyperbola becomes two intersecting straight lines, which approach in the limit two parallel lines as the vertex of the cone moves off to an infinite distance.

Hence a point, two intersecting straight lines, two parallel straight lines, and two coincident straight lines are all limiting cases of conic sections.

Under the head of conic sections we must therefore include:

- (1) *The Ellipse, including the circle and the point;*
- (2) *The Parabola;* (3) *The Hyperbola;* (4) *The Line-pair.*

EXAMPLES

1. Inscribe a sphere* tangent to the plane APB (fig. § 85) on the other side and thus show that the ellipse has another focus and a corresponding directrix; and that the two directrices are parallel and equidistant from the foci.
2. By means of these two inscribed spheres, prove the property of the ellipse given in § 34.
3. Inscribe spheres* in both sheets of the cone and show that the hyperbola also has two foci and two directrices.
4. Prove the property of the hyperbola stated in § 36.
5. Where are the foci and the directrices of the circle, the parabola, and two intersecting straight lines?

GENERAL EQUATION OF THE CONIC SECTIONS

87. To find the equation of a conic section in rectangular coordinates.

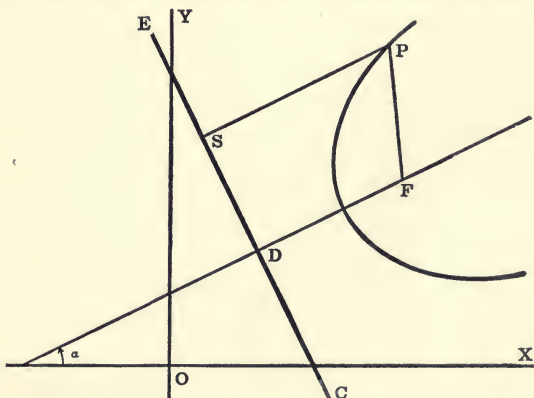

I. Let the equation of the directrix EC be

$$x \cos \alpha + y \sin \alpha - p = 0. \quad (1)$$

Let $F(k, l)$ be the corresponding focus.

Let $P(x, y)$ be any point on the conic.

Draw PS perpendicular to EC , and join P and F .

Then from equation (1) of § 86 we have

$$PF = e \cdot PS. \quad (2)$$

* For complete diagrams see *Some Mathematical Curves and their Graphical Construction*, by F. N. Willson, pp. 45, 46. Also his *Descriptive Geometry*, pp. 44, 45.

Now $PF^2 = (x - k)^2 + (y - l)^2, \quad [(2), \S 7.]$

and $PS = x \cos \alpha + y \sin \alpha - p. \quad [(4), \S 47.]$

Therefore the required equation is

$$(x - k)^2 + (y - l)^2 = e^2(x \cos \alpha + y \sin \alpha - p)^2. \quad (3)$$

Expanding (3) and collecting terms we have

$$(1 - e^2 \cos^2 \alpha)x^2 - 2(e^2 \sin \alpha \cos \alpha)xy + (1 - e^2 \sin^2 \alpha)y^2 + 2(e^2 p \cos \alpha - k)x + 2(e^2 p \sin \alpha - l)y + k^2 + l^2 - e^2 p^2 = 0. \quad (4)$$

Since equation (4) contains five arbitrary constants, k, l, α, p, e , it may be any equation of the second degree. That is, any equation of the second degree represents a conic section.

The most general equation of a conic is, therefore, the complete equation of the second degree, and may be written

$$ax^2 + 2hxy + by^2 + 2gx + 2fy + c = 0. \quad (5)$$

II. Let the directrix be taken as the y -axis, the principal axis, FD , (§ 85) as the x -axis. Then $\alpha = l = p = 0$, and $k = DF$. Therefore the equation of the conic (3) takes the simple form.

$$\left. \begin{aligned} (x - k)^2 + y^2 &= e^2 x^2, \\ (1 - e^2)x^2 + y^2 - 2kx + k^2 &= 0. \end{aligned} \right\} \quad (6)$$

If $x = 0$ in (6), then $y = \pm k\sqrt{-1}$.

Hence a conic does not intersect its directrix.

If $y = 0$, then there are two real values of x , viz.,

$$x_1 = \frac{k}{1 + e}, \quad x_2 = \frac{k}{1 - e}. \quad (7)$$

Therefore a conic section cuts its principal axis in two points. These points are called the **Vertices** of the conic. The point midway between the vertices is called the **Centre of the Conic**.

The **Latus Rectum** of a conic is the chord through either focus perpendicular to the principal axis.

To find its length, let $x = k$ in (6), then

$$y = \pm ek, \text{ and } 2y = \text{Latus Rectum} = 2ek.$$

The different cases corresponding to the different values of e will now be separately considered.

STANDARD EQUATIONS OF THE CONIC SECTIONS

88. THE PARABOLA. $e = 1$.

When $e = 1$, equations (7) of § 87 give

$$x_1 = \frac{1}{2}k = DO, \quad x_2 = \frac{k}{0} = \infty.$$

Hence the parabola has one vertex midway between the focus and directrix, and the other at infinity.*

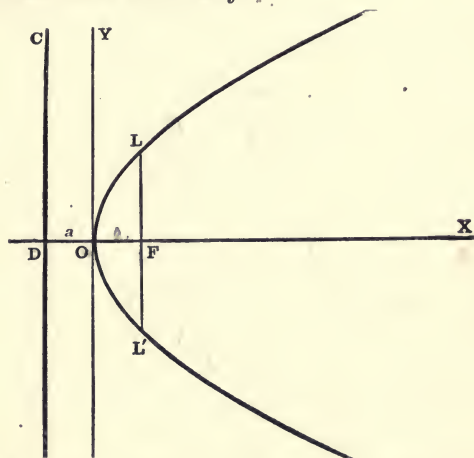

When $e = 1$, equation (6) of § 87 gives for the equation of the parabola referred to its axis and directrix

$$y^2 = 2k(x - \frac{1}{2}k). \quad (1)$$

Let $a = \frac{1}{2}k = DO = OF$; then this equation becomes

$$y^2 = 4a(x - a). \quad (2)$$

Now write $x + a$ in the place of x ; this moves the origin to the vertex $O(a, 0)$ [§ 53, (1)], and the equation becomes

$$y^2 = 4ax, \quad (3)$$

which is the *standard form* of the equation of the parabola.

When $x = a$ in (3), $y = \pm 2a$.

$$\therefore L'L = 4a = \text{Latus Rectum}.$$

Ex. Construct the parabola, having given the focus and the directrix.

* Compare this result with the position of B in the figure of § 85 when $\alpha = \beta$.

89. THE ELLIPSE. $e < 1$.

When $e < 1$, the two x -intercepts [(7), § 85] are both finite and positive; that is,

$$x_1 = \frac{k}{1+e} = DA < k,$$

$$x_2 = \frac{k}{1-e} = DA' > k.$$

Hence the ellipse has two vertices lying on the same side of the directrix, but on opposite sides of the focus.

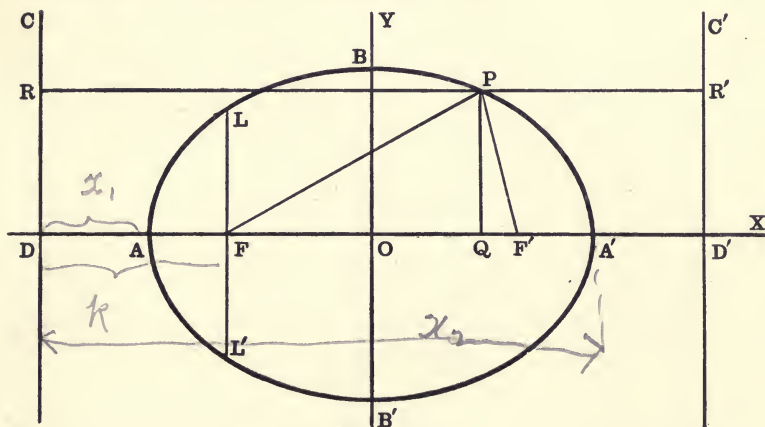

Let O be the centre, and let $AA' = 2a$.

$$\text{Then } 2a = x_2 - x_1 = \frac{k}{1-e} - \frac{k}{1+e} = \frac{2ek}{1-e^2} \quad (1)$$

$$\therefore \frac{a}{e} = \frac{k}{1-e^2};$$

$$\text{whence } k = \frac{a}{e} - ae. \quad (2)$$

$$\begin{aligned} \text{Also } DO &= \frac{1}{2}(x_1 + x_2) = \frac{1}{2} \left(\frac{k}{1+e} + \frac{k}{1-e} \right) \\ &= \frac{k}{1-e^2} = \frac{a}{e}. \end{aligned} \quad (3)$$

$$\therefore FO = DO - DF = \frac{a}{e} - k = ae. \quad (4)$$

Substituting in equation (6) of § 85 the value of k given by (2) gives for the equation of the ellipse referred to DC and DX

$$\left(x - \frac{a}{e} + ae\right)^2 + y^2 = e^2 x^2. \quad (5)$$

The origin may be transferred to the centre, $O\left(\frac{a}{e}, 0\right)$, by writing $x + \frac{a}{e}$ in the place of x [§ 53, (1)]; this gives

$$(x + ae)^2 + y^2 = e^2 \left(x + \frac{a}{e}\right)^2,$$

or

$$x^2(1 - e^2) + y^2 = a^2(1 - e^2).$$

$$\therefore \frac{x^2}{a^2} + \frac{y^2}{a^2(1 - e^2)} = 1. \quad (6)$$

When $x = 0$, we have

$$y = \pm a \sqrt{1 - e^2};$$

which gives the y -intercepts OB and OB' .

If these lengths are denoted by $\pm b$, we have

$$b^2 = a^2(1 - e^2), \quad (7)$$

and equation (6) takes the *standard form*

$$\frac{x^2}{a^2} + \frac{y^2}{b^2} = 1. \quad (8)$$

Since $e < 1$, $b < a$ from (7); therefore

$$B'B < AA'.$$

Hence the line AA' is called the **Major Axis**, and BB' is called the **Minor Axis** of the ellipse.

Take $OF' = FO$ and $OD' = DO$; draw $D'C'$ perpendicular to OX . Then F' is the other focus, and $D'C'$ the corresponding directrix (Ex. 1, p. 117). Hence the foci are the points $F'(ae, 0)$ and $F(-ae, 0)$ from (4); and the equations of directrices are, from (3),

$$x = \pm \frac{a}{e}. \quad (9)$$

Let $P(x, y)$ be any point on the ellipse; draw a line through P parallel to AA' meeting the directrices in R and R' , and draw PQ perpendicular to AA' .

* For a discussion of this equation see § 35.

Then

$$FP = e \cdot RP,$$

and

$$F'P = e \cdot R'P. \quad [(2), \text{§ } 87.]$$

$$\begin{aligned} \therefore FP &= e \cdot DQ = e(DO + OQ) \\ &= e\left(\frac{a}{e} + x\right) = a + ex, \end{aligned} \quad (10)$$

and

$$\begin{aligned} F'P &= e \cdot QD' = e(OD' - OQ) \\ &= e\left(\frac{a}{e} - x\right) = a - ex. \end{aligned} \quad (11)$$

Whence

$$FP + F'P = 2a. \quad (\text{Cf. § } 34.) \quad (12)$$

From equations (7) and (4) we get

$$ae = \sqrt{a^2 - b^2} = FO = OF'.$$

$$\therefore e = \frac{\sqrt{a^2 - b^2}}{a} = \frac{FF'}{AA'}.* \quad (13)$$

To find the length of the *latus rectum* we put $x = \pm ae$ in (8); this gives

$$y^2 = b^2(1 - e^2) = \frac{b^4}{a^2}. \quad \text{from (7)}$$

$$\therefore L'L = \frac{2b^2}{a}. \quad (14)$$

If $a = b$, equation (8) reduces to

$$x^2 + y^2 = a^2,$$

and equations (13), (4), and (3), respectively, give

$$e = 0, \quad FO = OF' = 0, \quad DO = OD' = \infty.$$

That is, the circle is the limiting form of the ellipse, as the eccentricity approaches zero, and the directrices recede to infinity.

Ex. Construct an ellipse, having given the foci and the length of the major axis.

* In all conics $e = \frac{\text{distance between foci}}{\text{distance between vertices}}$; both distances become infinite in the parabola, and both become zero in the case of two intersecting lines. (See also (11), § 90.)

90. THE HYPERBOLA. $e > 1$.

From equations (7) of § 87 we have for the vertices

$$x_1 = \frac{k}{1+e} \quad \text{and} \quad x_2 = \frac{k}{1-e}.$$

Since $e > 1$, $x_1 = DA < k$, and $x_2 = DA'$ is negative.

Therefore, the hyperbola has two vertices lying on the same side of the focus but on opposite sides of the directrix.

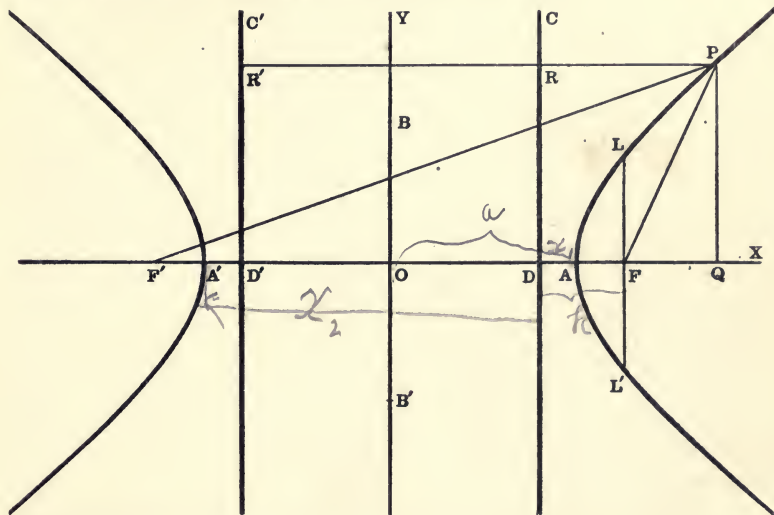

Let O be the centre, and let $A'A = 2a$.

Then

$$\begin{aligned} 2a &= A'D + DA = -x_2 + x_1 \\ &= \frac{k}{e-1} + \frac{k}{e+1} = \frac{2ek}{e^2-1}. \end{aligned} \quad (1)$$

$$\therefore \frac{a}{e} = \frac{k}{e^2-1} \quad \text{and} \quad k = ae - \frac{a}{e}. \quad (2)$$

$$\begin{aligned} DO &= \frac{1}{2}(x_1 + x_2) = \frac{1}{2} \left(\frac{k}{1+e} + \frac{k}{1-e} \right) \\ &= \frac{k}{1-e^2} = -\frac{a}{e}. \end{aligned} \quad (3)$$

$$FO = FD + DO = -\left(k + \frac{a}{e}\right) = -ae. \quad (4)$$

The equation of the hyperbola referred to DC and DX is, from (2), and (6) of § 87,

$$\left(x - ae + \frac{a}{e}\right)^2 + y^2 = e^2 x^2. \quad (5)$$

Moving the origin to the centre $O\left(-\frac{a}{e}, 0\right)$ gives

$$(x - ae)^2 + y^2 = e^2 \left(x - \frac{a}{e}\right)^2,$$

or
$$\frac{x^2}{a^2} + \frac{y^2}{a^2(1 - e^2)} = 1. \quad (6)$$

Since $e > 1$, the quantity $a^2(1 - e^2)$ is *negative*; if we put

$$-b^2 = a^2(1 - e^2),$$

or
$$b^2 = a^2(e^2 - 1), \quad (7)$$

equation (6) reduces to the *standard form*

$$\frac{x^2}{a^2} - \frac{y^2}{b^2} = 1. \quad (8)$$

When $x = 0$, $y = \pm b\sqrt{-1}$. Since these values of y are both imaginary, the hyperbola does not meet the line through its centre perpendicular to its principal axis in *real* points; but, if B, B' are points on this line such that $B'O = OB = b$, the line BB' is called the **Conjugate Axis**. The line AA' joining the vertices is called the **Transverse Axis**.

On the line OX take $OF' = FO$, and $OD' = DO$; then F' is the other focus and $D'C'$, perpendicular to OX , is the corresponding directrix (Ex. 3, p. 117). Hence the coordinates of the foci are $(\pm ae, 0)$, from (4), and the equations of the directrices are, from (3),

$$x = \pm \frac{a}{e}. \quad (9)$$

As in the ellipse, we find the latus rectum

$$LL' = \frac{2b^2}{a}. \quad (10)$$

Equations (7) and (4) give

$$ae = \sqrt{a^2 + b^2} = OF. \\ \therefore e = \frac{\sqrt{a^2 + b^2}}{a} = \frac{OF}{OA} = \frac{F'F}{A'A}. \quad (11)$$

Let $P(x, y)$ be any point on the hyperbola; draw a line through P parallel to AA' meeting the directrices in R and R' , and draw PQ perpendicular to AA' .

Then $FP = e \cdot RP$, $F'P = e \cdot R'P$. [(2), § 87.]

$$\therefore FP = e \cdot DQ = e(OQ - OD) = e\left(x - \frac{a}{e}\right) = ex - a; \quad (12)$$

$$\text{and } F'P = e \cdot D'Q = e(OQ + D'O) = e\left(x + \frac{a}{e}\right) = ex + a. \quad (13)$$

$$\text{Whence} \quad F'P - FP = 2a. \quad (\text{Cf. § 36.}) \quad (14)$$

If $a = b$, the equation of the hyperbola becomes

$$x^2 - y^2 = a^2. \quad (15)$$

This is called the *Equilateral* or *Rectangular Hyperbola*. (See §§ 169, 170.)

Then from (11), (3), and (4) we have, respectively,

$$e = \sqrt{2}, \quad OD = \frac{1}{2}a\sqrt{2}, \quad OF = a\sqrt{2}.$$

Ex. Construct a hyperbola, having given the foci and the distance between the vertices.

91. Limiting cases of conic sections.

If $k = 0$, equation (6) of § 87 reduces to

$$y^2 = x^2(e^2 - 1).$$

This equation represents *two straight lines*, which are real if $e > 1$, coincident if $e = 1$, and imaginary, but with a real point of intersection, if $e < 1$.

From (7) of § 87 we then have $x_1 = x_2 = 0$. Hence the foci, the vertices, and the centre of two intersecting lines all coincide on the directrix. The two directrices also coincide.

When $e = \infty$ (a being finite), the equation of the hyperbola [(8), § 90] reduces to $x^2 = a^2$, which represents two parallel lines. Equations (3) and (4) of § 90 then show that the foci of two parallel lines (considered as the limiting case of a hyperbola) are at infinity while their directrices coincide and are equidistant from the two lines.

Hence we must consider two intersecting lines, real or imaginary (*i.e.* a real point), two coincident lines, and two parallel lines as limiting cases of conic sections. (Cf. § 86.)

where

TANGENTS

92. To find the equation of the tangent to the conic represented by the general equation

$$ax^2 + 2hxy + by^2 + 2gx + 2fy + c = 0. \quad (1)$$

The equation of the tangent to any curve $f(x, y) = 0$ at the point (x', y') is (§ 62)

$$y - y' = \frac{dy'}{dx'}(x - x'). \quad (2)$$

For equation (1) we have found in § 61

$$\frac{dy}{dx} = -\frac{ax + hy + g}{hx + by + f}. \quad (3)$$

Therefore the required equation is

$$y - y' = -\frac{ax' + hy' + g}{hx' + by' + f}(x - x'), \quad (4)$$

or
$$axx' + h(xy' + x'y) + byy' + gx + fy = ax'^2 + 2hx'y' + by'^2 + gx' + fy'. \quad (5)$$

Add $gx' + fy' + c$ to both sides of (5); then, since (x', y') is on the conic, the right member will vanish and we have the required equation,

$$axx' + h(xy' + x'y) + byy' + g(x + x') + f(y + y') + c = 0. \quad (6)$$

Observe that the equation of the tangent at (x', y') is obtained from the equation of the conic by writing xx' for x^2 , $x'y + xy'$ for $2xy$, yy' for y^2 , $x + x'$ for $2x$, and $y + y'$ for $2y$. Note also that putting x for x' and y for y' in (6) reproduces the equation of the curve.

E.g. the equation of the tangent

to the circle	$x^2 + y^2 = r^2$	at the point (x', y') is	$xx' + yy' = r^2,$
to the parabola	$y^2 = 4ax$	at the point (x', y') is	$yy' = 2a(x + x'),$
to the ellipse	$\frac{x^2}{a^2} + \frac{y^2}{b^2} = 1$	at the point (x', y') is	$\frac{xx'}{a^2} + \frac{yy'}{b^2} = 1,$
to the hyperbola	$\frac{x^2}{a^2} - \frac{y^2}{b^2} = 1$	at the point (x', y') is	$\frac{xx'}{a^2} - \frac{yy'}{b^2} = 1.$

93. Two tangents can be drawn to a conic from any point, which will be real, coincident, or imaginary, according as the point is outside, on, or within the curve.

Let the equation of the conic be [§ 87, (6)]

$$ax^2 + y^2 + 2gx + g^2 = 0, \quad (1)$$

where $a \equiv 1 - e^2$, and $g \equiv -k$.

Let (h, k) be any point; then the equation of any line through this point will be (§ 43)

$$y - k = m(x - h). \quad (2)$$

Eliminating y between (1) and (2) gives

$$(a + m^2)x^2 + 2(km - hm^2 + g)x + h^2m^2 - 2hkm + k^2 + g^2 = 0. \quad (3)$$

The roots of (3) are, by § 24, the abscissas of the points of intersection of (1) and (2). If these roots are equal, the points of intersection will coincide and, by § 57, (2) will be tangent to (1). The condition that (3) shall have equal roots* is

$$(km - hm^2 + g)^2 = (a + m^2)(h^2m^2 - 2hkm + k^2 + g^2), \quad (4)$$

$$\text{or} \quad (ah^2 + 2gh + g^2)m^2 - 2(ahk + gk)m + (ak^2 + ag^2 - g^2) = 0. \quad (5)$$

Equation (5) is a quadratic in m whose roots are the slopes of the tangents from (h, k) to the conic. Since a quadratic equation has two roots, two tangents will pass through any point (h, k) .

The conic is, therefore, a curve of the *second class*.

The roots of (5) are real, equal, or imaginary, according as

$$ah^2 + k^2 + 2gh + g^2 >, =, \text{ or } < 0. \quad (6)$$

Therefore the tangents are real, coincident, or imaginary according as the point (h, k) is outside, on, or within the conic. (§ 20, II.) (The directrix is outside, the focus inside the conic.)

Since equation (3) is a quadratic in x , any straight line meets a conic in two points, which may be real, coincident, or imaginary.

Therefore the conic is also a curve of the *second order*.

If $e = 1$ and $m = 0$, then $a + m^2 = 0$, and hence one root of (3) is infinite (§ 77). Therefore a straight line parallel to the axis of the parabola meets the curve in one point at a finite distance, and in another at an infinite distance from the directrix.

* The two roots of $ax^2 + bx + c = 0$ will be equal, if $b^2 = 4ac$.

The method here used is worthy of special attention because of its wide application.

POLE AND POLAR

94. The equation of the tangent to the conic

$$ax^2 + y^2 + 2gx + g^2 = 0 \quad (1)$$

at the point (x', y') , if this point is on the conic, is (§ 92)

$$axx' + yy' + g(x + x') + g^2 = 0. \quad (2)$$

Suppose, however, that $P'(x', y')$ is not on the conic. Then what is (2)? It still has a meaning, still represents a straight line related in a definite way to the point (x', y') and the conic (1). Moreover this line will cut the conic in two points (§ 93).

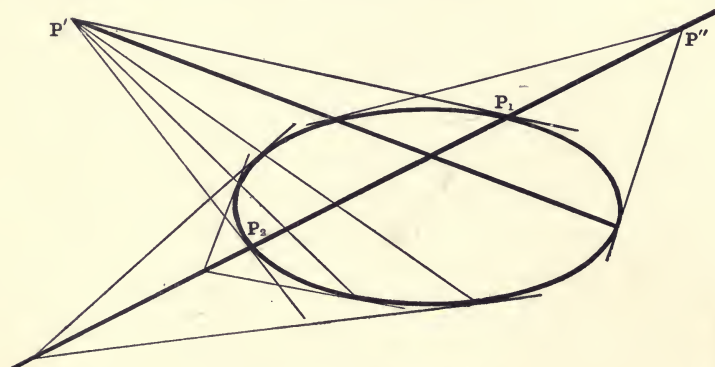

Let these points be $P_1(x_1, y_1)$ and $P_2(x_2, y_2)$.

Then the equations of the tangents at these points are (§ 92)

$$axx_1 + yy_1 + g(x + x_1) + g^2 = 0, \quad (3)$$

and
$$axx_2 + yy_2 + g(x + x_2) + g^2 = 0. \quad (4)$$

The conditions that (3) and (4) shall pass through (x', y') are

$$ax'x_1 + y'y_1 + g(x' + x_1) + g^2 = 0, \quad (5)$$

and
$$ax'x_2 + y'y_2 + g(x' + x_2) + g^2 = 0. \quad (6)$$

But (5) and (6) are also the conditions that (2) shall pass through both of the points (x_1, y_1) and (x_2, y_2) .

Therefore (2) is the line passing through the points of contact of the tangents from the point $P'(x', y')$.

The point (x', y') and the line (2) are called **Pole and Polar** with respect to the conic (1).

The tangents from the point (x', y') will be real or imaginary according as (x', y') is outside or inside the conic (§ 93); but the line (2) is real when (x', y') is real. So that there is always a real line passing through the imaginary points of contact of the two imaginary tangents drawn from a point within a conic.

If (x', y') is on the conic, the two tangents from it will coincide, and each of the points (x_1, y_1) and (x_2, y_2) will coincide with (x', y') . Therefore the tangent is the particular case of the polar which passes through its own pole. (See demonstration in § 169.)

95. If the polar of a point $P'(x', y')$ pass through $P''(x'', y'')$, then will the polar of P'' pass through P' . (See fig. § 94.)

Let the equation of the conic be [§ 93, (1)]

$$ax^2 + y^2 + 2gx + g^2 = 0. \quad (1)$$

The equations of the polars of P' and P'' are

$$axx' + yy' + g(x + x') + g^2 = 0 \quad (2)$$

and

$$axx'' + yy'' + g(x + x'') + g^2 = 0. \quad (\S 94.) \quad (3)$$

The line (2) will pass through the point P'' if

$$ax'x'' + y'y'' + g(x' + x'') + g^2 = 0; \quad (4)$$

but this is also the condition that (3) shall pass through P' , which proves the proposition.

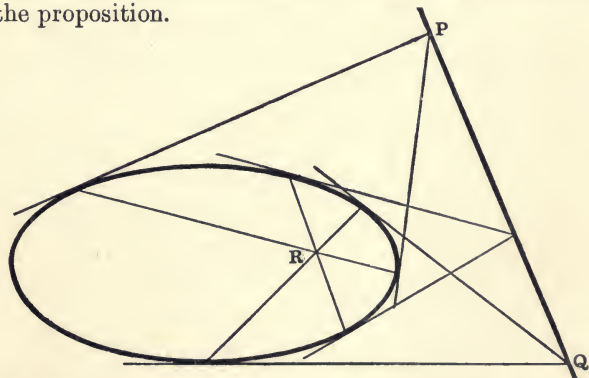

COR. I. The locus of the poles of all lines passing through a fixed point is a straight line; viz. the polar of the fixed point.

COR. II. If the polars of two points P and Q meet in R , then R is the pole of the line PQ .

Two straight lines are said to be *conjugate* with respect to a conic when each passes through the pole of the other.

Two points are said to be *conjugate* with respect to a conic when each lies on the polar of the other.

EXAMPLES

Find the equations of the tangent and normal to

- | | |
|--------------------------------------|--------------------------------------|
| 1. $x^2 = 2y$, at $(-2, 2)$. | 2. $y^2 = 8x$, at $(2, -4)$. |
| 3. $x^2 + y^2 = 25$, at $(4, -3)$. | 4. $x^2 - y^2 = 16$, at $(-5, 3)$. |
| 5. $x^2 + 4y^2 = 8$, at $(-2, 1)$. | 6. $2y^2 - x^2 = 4$, at $(2, -2)$. |

Find the equations of the tangents to the following conics at the origin :

- | | |
|---------------------------|----------------------------------|
| 7. $x^2 + y^2 + 2x = 0$. | 8. $x^2 + 2x + 3y = 0$. |
| 9. $2xy + 5x - 3y = 0$. | 10. $3x^2 - 2xy + 4x - 2y = 0$. |
11. State a rule for finding the tangent to a conic at the origin.

Find the polar of the point

12. $(3, 2)$ with respect to $y^2 = 6x$.
13. $(-2, -4)$ with respect to $x^2 + y^2 = 4$.
14. $(1, 1)$ with respect to $2x^2 + 3y^2 = 1$.
15. $(0, 0)$ with respect to $2x^2 - 3y^2 + 12x - 6y + 21 = 0$.
16. Give a rule for writing the equation of the polar of the origin.

Find the tangents to the following conics drawn from the given points (see § 93):

- | | |
|------------------------------------|---|
| 17. $y^2 = 4x$, $(2, 3)$. | 18. $y^2 = 5x$, $(-3, -1)$. |
| 19. $x^2 + y^2 = 25$, $(-1, 7)$. | 20. $9x^2 + 25y^2 = 225$, $(10, -3)$. |

21. Show that the polar of the focus is the directrix.

What is the locus of the intersection of tangents at the ends of focal chords? (Use equation (1), § 93.)

22. Show that the line joining the focus to any point on the directrix is perpendicular to the polar of the latter point.

23. Show that tangents to a conic at the ends of a chord through the centre are parallel.

24. What is the polar of the centre of a conic? Where is the pole of a line passing through the centre?

25. What is the pole of $x \cos \alpha + y \sin \alpha = p$ with respect to

$$x^2 + y^2 = r^2? \quad y^2 = 2x?$$

CHAPTER VIII

THE PARABOLA

96. *Standard equations of the tangent, polar, and normal to the parabola.*

In studying the properties of the parabola in this chapter we shall use the standard form of the equation found in § 88, viz.

$$y^2 = 4ax. \quad (1)$$

Then the focus is the point $(a, 0)$, the directrix is the line $x = -a$, and the latus rectum is $4a$.

Equation (6), § 92, applied to (1) gives

$$yy' = 2a(x + x'), \quad (2)$$

as the equation of the tangent at the point (x', y') , if (x', y') is on the curve; but always the equation of the polar of (x', y') , (§ 94), with respect to the parabola (1).

The equation of the normal at the point (x', y') on the curve is [(2), § 62]

$$y - y' = -\frac{y'}{2a}(x - x'), \quad (3)$$

or
$$2a(y - y') + y'(x - x') = 0. \quad (4)$$

The tangent at the vertex $(0, 0)$ is the line $x = 0$; and the normal at the same point is $y = 0$, *i.e.* the axis of the curve.

Ex. 1. Show that the equation of the parabola is

$$y^2 = 4a(x \pm a),$$

according as the origin is at the focus or on the directrix.

Ex. 2. Change the equations of the parabolas

$$(y - k)^2 = 4a(x - h) \text{ and } (x - h)^2 = 4a(y - k)$$

to the standard form, and show that their vertices are at the point (h, k) .

Ex. 3. What relation does the line (3) have to the parabola when the point (x', y') is not on the curve?

97. Geometric properties of the parabola.

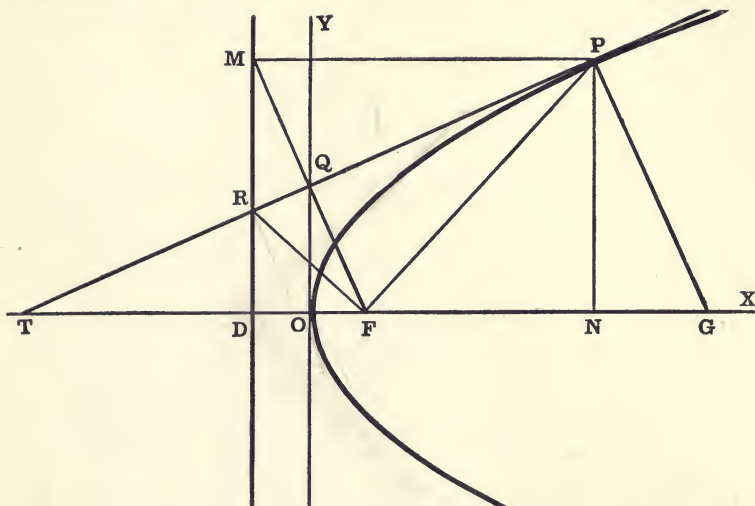

Let the tangent at the point $P(x', y')$ meet the axis in T , the directrix in R , and the tangent at the vertex in Q . Let PM and PN be the perpendiculars from P to the directrix and axis, respectively.

Let the normal at P meet the axis in G .

Then we have the following properties :

$$TO = ON = x'. \quad [(2), \S 96.] \quad (1)$$

$$\therefore \text{Subtangent} = TN = 2 ON = 2 x'. \quad (2)$$

$$OQ = \frac{1}{2} NP = \frac{1}{2} y'. \quad (3)$$

$$TF = FP = FG = a + x'. \quad (4)$$

$$\angle FPR = \angle MPR. \quad (5)$$

$$\angle RFP = \angle RMP = \frac{1}{2} \pi. \quad (\text{See Ex. 22, p. 130.}) \quad (6)$$

$$FM \text{ is perpendicular to } TP. \quad (7)$$

$$FM, PT, \text{ and } OY \text{ meet in a point.} \quad (8)$$

$$OG = 2 a + x'. \quad [(4), \S 96.] \quad (9)$$

$$\therefore \text{Subnormal} = NG = 2 a, \text{ a constant.} \quad (10)$$

The use of parabolic reflectors depends on the property expressed in (5). Let the student explain.

Properties (5) and (7) suggest a method of drawing tangents from an exterior point. Show how this can be done.

98. *Equations of the tangent and normal in terms of the slope m .*

The equation of the tangent [(2), § 96] may be written

$$y = \frac{2a}{y'}x + \frac{2ax'}{y'} = \frac{2a}{y'}x + \frac{4ax'}{2y'}, \quad (1)$$

or

$$y = \frac{2a}{y'}x + \frac{y'}{2}. \quad (2)$$

Let $\frac{2a}{y'} = m$; then $\frac{y'}{2} = \frac{a}{m}$, and (2) may be written

$$y = mx + \frac{a}{m}, \quad (3)$$

which is the required equation. That is, the line (3) will touch the parabola $y^2 = 4ax$, whatever the value of m may be.

In a similar manner it can be shown from (3), § 96, that the equation of the normal expressed in terms of its slope is

$$y = mx - 2am - am^3. \quad (4)$$

EXAMPLES

1. Find the equations of the tangents, and the normals at the ends of the latus rectum.

2. Show that the line $y = 3x + \frac{a}{3}$ touches the parabola $y^2 = 4ax$; and also that $y = 4x + \frac{a}{2}$ touches $y^2 = 8ax$.

3. Find the equation of the tangent to $y^2 = 12x$ which makes an angle of 60° with the x -axis.

4. Find the tangent to the parabola $y^2 = 6x$ which makes an angle of 45° with the x -axis.

Find the coordinates of the vertex, of the focus, the length of the latus rectum, and the equation of the directrix of each of the following parabolas:

5. $y^2 = 3x + 6$.

6. $x^2 + 4x + 2y = 0$.

7. $(y - 4)^2 = 6(x + 2)$.

8. $4(x - 3)^2 = 3(y + 1)$.

9. $y^2 + 8x - 6y + 1 = 0$.

where

99. *The locus of the middle points of a system of parallel chords of a parabola is a straight line parallel to the axis of the parabola.*

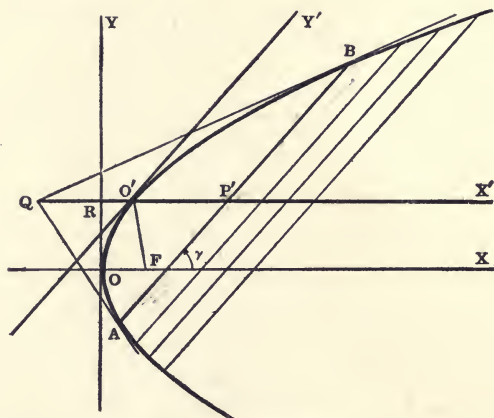

Let AB be any one of the chords, let $P'(x', y')$ be its middle point, and let γ be the angle it makes with the axis of the parabola.

Then the equation of AB may be written [(4), § 43]

$$\frac{x - x'}{\cos \gamma} = \frac{y - y'}{\sin \gamma} = r, \quad (1)$$

or
$$x = x' + r \cos \gamma, \quad y = y' + r \sin \gamma. \quad (2)$$

Let the equation of the parabola be

$$y^2 = 4ax. \quad (3)$$

Substituting in (3) the values of x and y given by (2), we have for the points common to the chord and the curve

$$(y' + r \sin \gamma)^2 = 4a(x' + r \cos \gamma),$$

or
$$r^2 \sin^2 \gamma + 2(y' \sin \gamma - 2a \cos \gamma)r + y'^2 - 4ax' = 0, \quad (4)$$

a quadratic equation in r , whose roots are represented by the distances $P'B$ and $P'A$. Since P' is the middle point of AB , the sum of these roots is zero. That is,

$$y' \sin \gamma - 2a \cos \gamma = 0. \quad (\S 68.)$$

Whence
$$y' = 2a \cot \gamma = \frac{2a}{m}, \quad (5)$$

where m is the constant slope of the chords.

The coordinates of P' therefore satisfy the equation

$$y = \frac{2a}{m} = 2a \cot \gamma. \quad (6)$$

Hence the locus of P' , as AB moves keeping m constant, is a straight line $O'X'$ parallel to the axis of the parabola.

DEFINITION. The locus of the middle points of a system of parallel chords of a conic is called a **Diameter**; and the chords it bisects are oblique double ordinates to that diameter considered as an axis of abscissas.

We have seen in § 93 that a diameter of a parabola meets the curve in only *one* point at a finite distance from the directrix. This point is called the **Extremity** of the diameter.

COR. The line (6) meets the curve in O' where

$$x = \frac{a}{m^2} = RO', \quad y = \frac{2a}{m}. \quad (7)$$

The equation of the tangent at O' is, therefore [(2), § 96],

$$y = mx + \frac{a}{m}. \quad (8)$$

Hence the tangent at the extremity of a diameter is parallel to the chords bisected by that diameter.

100. *To find the equation of a parabola when the axes are any diameter and the tangent at its extremity.*

Using the figure of § 99, and keeping the same notation, we will let $O'P' = x$, the new abscissa, and $P'B = y$, the new ordinate.

Then y is always the same as r of equation (4), § 99. And since the coefficient of the first power of r in this equation is zero, we have

$$y^2 = \frac{4ax' - y'^2}{\sin^2 \gamma}, \quad (1)$$

where $y' = \frac{2a}{m}, \quad [(5), \text{§ } 99.]$

and $x' = RO' + O'P' = \frac{a}{m^2} + x. \quad [(7), \text{§ } 99.]$

$$\therefore y^2 = \frac{4a}{\sin^2 \gamma} x. \quad (2)$$

$$\begin{aligned} \text{Now } FO' &= a + RO' && [(4), \text{ § 97.}] \\ &= a \frac{(1 + m^2)}{m^2} = a \frac{1 + \tan^2 \gamma}{\tan^2 \gamma} = \frac{a}{\sin^2 \gamma}. \end{aligned} \quad (3)$$

Therefore, if $a' = \frac{a}{\sin^2 \gamma} = FO'$, the required equation is

$$y^2 = 4 a' x. \quad (4)$$

Hence the equation $y^2 = 4 ax$ always represents a parabola, the x -axis being a diameter, the y -axis the tangent at its extremity, a the distance from the focus to the origin, and $4 a$ the length of the focal chord parallel to the y -axis.

Formula (6), § 92, by means of which equation (2), § 96, was obtained, and also the derivation of equation (3), § 98, from equation (2), § 96, hold good equally whether the axes are rectangular or not. That is, if the equation of a parabola is $y^2 = 4 ax$, the line

$$yy' = 2 a(x + x') \quad (5)$$

will be the tangent at the point (x', y') if the point is on the curve; but always the polar of (x', y') with respect to the parabola. And the line

$$y = mx + \frac{a}{m} \quad (6)$$

will also touch the parabola for all values of m , the meaning of n , being that given in § 50.

Cor. The polar of any point with respect to a parabola is parallel to the chords bisected by the diameter through the point.

Conversely, the locus of the poles of parallel chords is the bisecting diameter.

For the polar of any point $(x', 0)$ is, by (5), $x = -x'$.

EXAMPLES ON CHAPTER VIII

1. Find the equation of that chord of the parabola $y^2 = 6x$ which is bisected by the point $(4, 3)$.
- ✓ 2. Find the equation of the chord of $x^2 = -8y$ whose middle point is $(-3, -2)$.
3. Find the equations of the tangents drawn from the point $(-2, 2)$ to the parabola $y^2 = 6x$.

4. Show that the axis of the parabola $y^2 = 8x$ divides each of the chords whose equations are $\frac{y}{\sin 30^\circ} = \frac{x \pm 2}{\cos 30^\circ}$ into two segments whose product is 64 .

5. For what point on the parabola $y^2 = 4ax$ is (1) the subtangent equal to the subnormal, and (2) the normal equal to the difference between the subtangent and the subnormal?

6. Show that the lines $y = \pm(x + 2a)$ touch both the parabola $y^2 = 8ax$ and the circle $x^2 + y^2 = 2a^2$.

7. Find the equation of the common tangent to the parabolas $y^2 = 4ax$ and $x^2 = 4by$. Show also that if $a = b$, the line touches both at the end of the latus rectum.

8. Two equal parabolas, A and B , have the same vertex and their axes in opposite directions. Prove that the locus of the poles with respect to B of tangents to A is the parabola A .

9. Show that the locus of the poles of tangents to the parabola $y^2 = 4ax$ with respect to the parabola $y^2 = 4bx$ is the parabola $ay^2 = 4b^2x$.

10. Show that for all values of m the line

$$y = m(x + a) + \frac{a}{m} \text{ will touch } y^2 = 4a(x + a);$$

$$y = m(x - a) + \frac{a}{m} \text{ will touch } y^2 = 4a(x - a);$$

and $(y - k) = m(x - h) + \frac{a}{m}$ will touch $(y - k)^2 = 4a(x - h)$.

11. If (x', y') and (x'', y'') are the points of contact of two tangents to $y^2 = 4ax$, show that the coordinates of their point of intersection are

$$x = \sqrt{x'x''}, \quad y = \frac{1}{2}(y' + y'').$$

12. Show that the directrix is the locus of the vertex of a right angle whose sides slide upon a parabola. (§ 98.)

13. Two lines are perpendicular to one another; one of them is tangent to $y^2 = 4a(x + a)$, and the other is tangent to $y^2 = 4b(x + b)$; show that these lines intersect on the line $x + a + b = 0$.

14. Show that the line $lx + my + n = 0$ will touch the parabola $y^2 = 4ax$, if $ln = am^2$.

15. If the chord PQR passes through a fixed point Q on the axis of the parabola, show that the product of the ordinates, and also the product of the abscissas of the points P and R , is constant.

16. Find the coordinates of the point of intersection of $y = mx + \frac{a}{m}$ and $y = m'x + \frac{a}{m'}$. Show that the locus of this point is a straight line if mm' is constant. What is the locus when $mm' = -1$?

17. If perpendiculars be let fall on any tangent to a parabola from two points on the axis which are equidistant from the focus, the difference of their squares will be constant.

18. The vertex A of a parabola is joined to any point P on the curve, and PQ is drawn at right angles to AP to meet the axis in Q . Prove that the projection of PQ on the axis is always equal to the latus rectum.

19. If P , Q , and R be three points on a parabola whose ordinates are in geometrical progression, the tangents at P and R will meet on the ordinate of Q .

20. Show that the locus of the intersection of two tangents to a parabola at points on the curve whose ordinates are in a constant ratio is a parabola.

21. Prove that the circle described on a focal radius as diameter touches the tangent drawn through the vertex.

22. Prove that the circle described on a focal chord as diameter touches the directrix.

23. Find the locus of the point of intersection of two tangents to a parabola which make a given angle α with one another.

If $\alpha = 45^\circ$, show that the locus is $y^2 - 4ax = (x + a)^2$.

If $\alpha = 60^\circ$, show that the locus is $y^2 - 3x^2 - 10ax - 3a^2 = 0$.

[*Suggestion.* The line $y = mx + \frac{a}{m}$ will go through (x', y') if $m^2x' - my' + a = 0$. The roots of this equation are the slopes of the two tangents which meet in (x', y') . Let m_1, m_2 be these roots, then see § 68.]

24. The two tangents from a point P to the parabola $y^2 = 4ax$ make angles $\tan^{-1}m_1$ and $\tan^{-1}m_2$ with the x -axis. Find the locus of P , (1) when $m_1 + m_2$ is constant, (2) when $m_1^2 + m_2^2$ is constant, and (3) when m_1m_2 is constant.

25. If K is the area of a triangle inscribed in the parabola $y^2 = 4ax$, and K' is the area of the triangle formed by the tangents at the vertices of the inscribed triangle, prove that

$$8aK = 16aK' = (y_1 \sim y_2)(y_2 \sim y_3)(y_3 \sim y_1),$$

where y_1, y_2, y_3 are the ordinates of the vertices of the inscribed triangle. (See Ex. 11.)

Find the locus of the middle points

26. Of all ordinates of a parabola.

27. Of all focal radii.

28. Of all chords through the fixed point (h, k) .

As special cases, let (h, k) be (1) the focus, (2) the vertex, (3) the point $(4a, 0)$, and (4) the point $(-a, 0)$.

29. Show that the parabola is concave towards its axis.

CHAPTER IX

THE CIRCLE

101. *Equations of the circle, and the corresponding equations of the tangent, polar, and normal.*

We have seen in § 32 that the equation of the circle whose radius is r takes the simple form

$$x^2 + y^2 = r^2, \quad (1)$$

when the origin is at the centre; while if the centre is at the point (a, b) the equation may be written

$$(x - a)^2 + (y - b)^2 = r^2. \quad (2)$$

Moreover, we have found in § 87 that the locus of any equation of the second degree is a conic. Now the conic represented by the general equation (5), § 87, will be a circle if $a = b$ and $h = 0$. For this equation may then be written

$$x^2 + y^2 + 2gx + 2fy + c = 0. \quad (3)$$

Equation (3) may be put in the form of (2), which gives

$$(x + g)^2 + (y + f)^2 = g^2 + f^2 - c. \quad (4)$$

Hence the locus of (3) is a circle whose centre is the point $(-g, -f)$, and the radius is equal to $\sqrt{g^2 + f^2 - c}$.

The circle will therefore be real, a point, or imaginary according as $g^2 + f^2 - c >, =, \text{ or } < 0$.

By applying the rule of § 92 to equations (1), (2), and (3), respectively, we obtain

$$xx' + yy' = r^2, \quad (5)$$

$$(x - a)(x' - a) + (y - b)(y' - b) = r^2, \quad (6)$$

and
$$xx' + yy' + g(x + x') + f(y + y') + c = 0. \quad (7)$$

These are the equations of the tangent to the circles (1), (2), (3), respectively, at the point (x', y') if this point is on the curve; but,

by § 94, they are always the equations of the polar of the point (x', y') with respect to the circles represented by (1), (2), (3).

Since the normal (§ 57) at any point (x', y') of the circle $x^2 + y^2 = r^2$ is perpendicular to (5), its equation is [(2), § 62]

$$y - y' = \frac{y'}{x'}(x - x'),$$

or
$$xy' - x'y = 0. \quad (8)$$

That is, the normal at any point of a circle passes through the centre.

The equations of the normals to the circles (2) and (3) at the point (x', y') are, respectively [(2), § 62],

$$y - y' = \frac{y' - b}{x' - a}(x - x'), \quad (9)$$

and
$$y - y' = \frac{y' + f}{x' + g}(x - x'); \quad (10)$$

or
$$xy' - x'y - b(x - x') + a(y - y') = 0, \quad (11)$$

and
$$xy' - x'y + f(x - x') - g(y - y') = 0. \quad (12)$$

The general equation of the circle (3), or (2), contains three parameters, or constants. Therefore a circle can be made to satisfy three conditions, and no more. If we wish to find the equation of a circle which satisfies three given conditions, we assume the equation to be of the form (3), or (2), and then determine the values of the constants g, f, c , or a, b, r , from the given conditions.

Ex. Find the equation of the circle passing through the three points $(0, 1)$, $(2, 0)$, and $(0, -3)$.

Let the equation of the required circle be

$$x^2 + y^2 + 2gx + 2fy + c = 0. \quad (1)$$

Since the given points are on the circle, their coordinates must satisfy equation (1).

$$\therefore 1 + 2f + c = 0, \quad 4 + 4g + c = 0, \quad 9 - 6f + c = 0.$$

Whence we find $g = -\frac{1}{4}$, $f = 1$, and $c = -3$. Substituting these values in (1) the required equation becomes $x^2 + y^2 - \frac{1}{2}x + 2y - 3 = 0$.

The centre is the point $(\frac{1}{4}, -1)$, and the radius is $\frac{1}{4}\sqrt{65}$.

102. *A geometrical construction for the polar of a point with respect to a circle.*

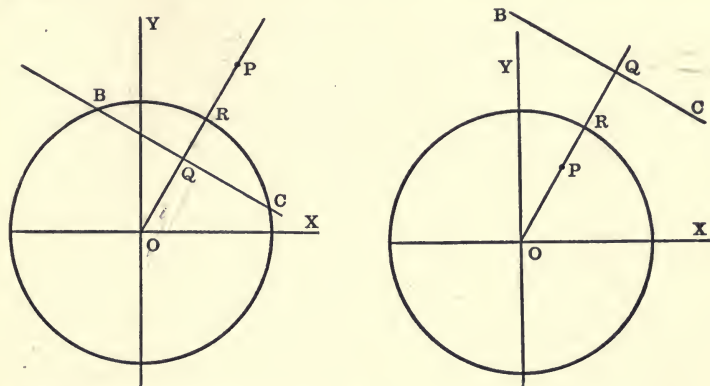

Let the equation of the circle be

$$x^2 + y^2 = r^2. \quad (1)$$

Let $P(x', y')$ be any point, BC its polar, and let OP and BC intersect in Q . Then the equation of BC is [(5), § 101]

$$xx' + yy' = r^2, \quad (2)$$

and the equation of the line OP is (§ 44)

$$xy' - x'y = 0. \quad (3)$$

Hence BC is perpendicular to OP (§ 45), and therefore

$$OQ = \frac{r^2}{\sqrt{x'^2 + y'^2}}. \quad [(5), § 47.] \quad (4)$$

Also $OP = \sqrt{x'^2 + y'^2}. \quad [(4), § 7.] \quad (5)$

$$\therefore OP \cdot OQ = r^2. \quad (6)$$

We therefore have the following construction for the polar of a point P . Draw OP and let it cut the circle in R ; then construct a third proportional, OQ , to OP and r , *i.e.* take Q on the line OP , such that $OP:OR = OR:OQ$, and draw a line through Q perpendicular to OP .

Ex. 1. Construct the pole of a given line.

103. To find the equation of the tangent to the circle

$$x^2 + y^2 = r^2 \quad (1)$$

in terms of its slope m .

The line $y = mx + b$ (2)

will touch the circle (1) if the perpendicular distance from it to the origin is equal to the radius r of the circle; that is, (§ 47) if

$$r = \frac{b}{\sqrt{1+m^2}}, \text{ or } b = r\sqrt{1+m^2}. \quad (3)$$

Therefore the straight line

$$y = mx + r\sqrt{1+m^2} \quad (4)$$

will touch the circle (1) for all values of m .

Since either sign may be given to the radical $\sqrt{1+m^2}$ in (3), it follows that there are *two* tangents to the circle for every value of m ; *i.e.* there are two tangents parallel to any given straight line.

Ex. 1. Derive equation (3) by treating (1) and (2) simultaneously and taking the condition for equal roots.

EXAMPLES

Find the equation of the circle passing through the three points

- | | |
|--------------------------------|-----------------------------|
| 1. (1, 0), (6, 0), (0, 4). | 2. (0, 0), (1, 1), (4, 0). |
| 3. (2, -3), (3, -4), (-2, -1). | 4. (1, 2), (3, -4), (5, 6). |

Find the equations of the tangents to the circle

5. $x^2 + y^2 = 4$ parallel to $2x + 3y + 1 = 0$.
 6. $x^2 + y^2 = 6x$ parallel to $3x - 2y + 2 = 0$.

Find the polar of the point

7. (1, 2) with respect to $x^2 + y^2 = 5$.
 8. (3, -2) with respect to $3(x^2 + y^2) = 14$.
 9. (-4, 1) with respect to $x^2 + y^2 - 2x + 6y + 7 = 0$.

Find the polar of the line

10. $2x + y = 1$ and $x - 3y = 1$ with respect to $x^2 + y^2 = 2$.
 11. $x - 2y = 3$ and $2x + y = 4$ with respect to $x^2 + y^2 = 6$.
 12. $x + y + 1 = 0$ with respect to $x^2 + y^2 + 4x - 6y + 11 = 0$.

1. done

104. To find the length of a tangent drawn from a given point $P(x', y')$ to a given circle.

Let the equation of the circle be

$$(x - a)^2 + (y - b)^2 - r^2 = 0. \quad (1)$$

Let C be the centre and PT one tangent from P .

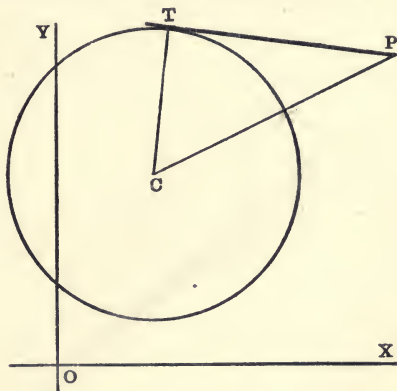

Then, since CPT is a right triangle,

$$PT^2 = CP^2 - CT^2.$$

But $CT^2 = r^2$, and $CP^2 = (x' - a)^2 + (y' - b)^2$. [§ 7, (2).]

$$\therefore PT^2 = (x' - a)^2 + (y' - b)^2 - r^2. \quad (3)$$

That is, the square of the tangent is found by substituting the coordinates x', y' of the given point in the left member of equation (1).

Since the general equation of the circle,

$$x^2 + y^2 + 2gx + 2fy + c = 0, \quad (4)$$

can be put in the form of (1) by merely adding and subtracting g^2 and f^2 in the first member, it follows that if the coordinates of any point are substituted in the first member of (4) the result will be equal to the square of the length of the tangent drawn from the point to the circle; or the product of the segments of any chord (or secant) drawn through the point. (See proof of § 154.)

Ex. 1. What is the meaning of (3) when the second member is negative? *(Answer must make circle)*

Ex. 2. What is represented by c in equation (4)?

Ex. 3. Where is the origin if c is positive? if c is zero? if c is negative?

105. If a circle passes through the common points of two given circles, tangents drawn from any point on it to the two given circles are in a constant ratio.

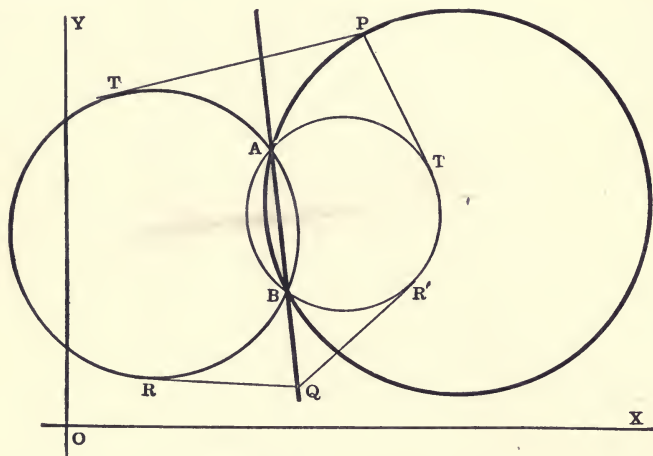

Let $S \equiv x^2 + y^2 + 2gx + 2fy + c = 0$ (1)

and $S' \equiv x^2 + y^2 + 2g'x + 2f'y + c' = 0$, (2)

be the equations of the two given circles.

Then the locus of $S = \lambda S'$, i.e. (See Ex. 5, p. 62.)

$$x^2 + y^2 + 2gx + 2fy + c = \lambda(x^2 + y^2 + 2g'x + 2f'y + c'), \quad (3)$$

for all values of λ , will pass through the common points A, B , of (1) and (2). Moreover, (3) is a circle (§ 101), and therefore, for different values of λ , represents all circles through the intersection of (1) and (2).

Let $P(x', y')$ be any point on (3); let PT and PT' be the tangents to (1) and (2) respectively. Then the coordinates x', y' must satisfy (3), and we therefore have

$$x'^2 + y'^2 + 2gx' + 2fy' + c = \lambda(x'^2 + y'^2 + 2g'x' + 2f'y' + c'). \quad (4)$$

Therefore $PT^2 = \lambda \cdot PT'^2$, (§ 104.) (5)

which proves the proposition, since λ is constant for any particular circle.

When $\lambda = 1$, it is easy to show that the radius and the coordinates of the centre (§ 101) of the circle represented by equation (3) all become infinite. In this case the equation reduces to

$$2(g - g')x + 2(f - f')y + c - c' = 0, \quad (6)$$

which is of the first degree, and therefore represents the straight line AB through the common points of the two given circles.

Let QR and QR' be tangents to $S = 0$ and $S' = 0$, respectively, from any point Q on AB ; then, since ABQ is the circle through the common points of (1) and (2) corresponding to $\lambda = 1$, it follows from (5) that

$$QR = QR'. \quad (7)$$

That is, tangents drawn to the two given circles from any point on the line (6) are equal.

It is to be noticed that the straight line given by (6) is in all cases real, provided g, f, c, g', f', c' are real, although the circles $S = 0$ and $S' = 0$ may not intersect in real points; in fact one or both of the circles may be wholly imaginary. We have here, therefore, the case of a real straight line passing through the imaginary points of intersection of two real or imaginary circles. (Cf. § 94.)

DEFINITION. The straight line through the points of intersection (real or imaginary) of two circles is called the **Radical Axis** of the two circles.

From equation (7) it follows that the radical axis may also be defined as the locus of the points from which tangents drawn to the two circles are equal to one another.

COR. *If the coefficients of x^2 in S and S' are unity, the equation of the radical axis of the two circles $S = 0$ and $S' = 0$ is $S - S' = 0$.*

Ex. 1. Show that the radical axis of two circles is perpendicular to the line joining their centres.

Ex. 2. If tangents are drawn to two circles from any point on a line parallel to their radical axis, show that the difference of the squares of these tangents is constant.

Ex. 3. Show that the radical axis of two circles divides the line joining their centres into two segments, such that the difference of their squares is equal to the difference of the squares of the radii.

106. *The radical axes of three circles, taken in pairs, meet in a point.*

Let $S_1 = 0$, $S_2 = 0$, $S_3 = 0$ be the equations of three circles, in each of which the coefficient of x^2 is unity.

Then the equations of their three radical axes are (§ 105, Cor.)

$$S_1 - S_2 = 0, \quad S_2 - S_3 = 0, \quad S_3 - S_1 = 0.$$

The sum of any two of these equations is equivalent to the third. Hence they form a consistent system, and therefore their loci meet in a point. Or, prove by § 49, letting $\lambda = 1$.

This point is called the **Radical Centre** of the three circles.

EXAMPLES ON CHAPTER IX

Find the length of the tangents (or the product of the segments of the chords) drawn from the points

1. $(3, 2)$, $(5, -4)$ to the circle $x^2 + y^2 = 4$.
2. $(-3, 2)$, $(4, -4)$ to the circle $x^2 + y^2 = 25$.
3. $(3, -2)$, $(1, 3)$ to the circle $x^2 + y^2 - 2x - 4y = 0$.
4. $(2, 1)$, $(0, 0)$ to the circle $2(x^2 + y^2) - 12x - 4y + 15 = 0$.
5. $(0, 0)$, $(-2, -5)$ to the circle $x^2 + y^2 - 6x + 4y + 4 = 0$.
6. $(0, 0)$, $(6, -3)$ to the circle $x^2 + y^2 + 6x - 8y - 11 = 0$.

Find the radical axis of the circles

7. $x^2 + y^2 + 6x - 4y - 3 = 0$ and $x^2 + y^2 - 4x + 8y - 5 = 0$.
8. $x^2 + y^2 - 8x - 10y + 25 = 0$ and $x^2 + y^2 + 8x - 2y + 8 = 0$.
9. $x^2 + y^2 + ax + by - c = 0$ and $ax^2 + ay^2 + a^2x + b^2y = 0$.
10. Find the radical axis and the length of the common chord of the circles $x^2 + y^2 + ax + by + c = 0$ and $x^2 + y^2 + bx + ay + c = 0$.
11. Show that the three circles

$$\begin{aligned} x^2 + y^2 - 2x - 4y = 0, & \quad x^2 + y^2 - 6x + 4y + 4 = 0, \\ x^2 + y^2 - 8x + 8y + 6 = 0 & \end{aligned}$$

have a common radical axis. Find the equation of a fourth circle such that the four shall have a common radical axis.

Find the radical centre of the three circles

12. $x^2 + y^2 - 4x + 8y - 5 = 0$, $x^2 + y^2 - 8x - 10y + 25 = 0$,
 $x^2 + y^2 + 8x + 11y - 10 = 0$.
13. $x^2 + y^2 + 6x - 8y + 9 = 0$, $x^2 + y^2 + 8x + 2y + 9 = 0$,
 $2(x^2 + y^2) - 5(3x + y) + 18 = 0$.

- ✓ 14. What is the equation of the normal in terms of its slope ?
- ✓ 15. How many normals can be drawn from a point to a circle ?
16. Find the equation of a circle passing through $(0, 4)$ and $(6, 0)$, and having $\sqrt{13}$ for radius.
- ✓ 17. Find the equation of a circle whose centre is $(3, 4)$ and which touches the line $4x - 3y + 20 = 0$.
18. Find the equation of the circle passing through the point $(-3, 6)$ and touching both axes.
- ✓ 19. Find the equation of the circle touching the line $y = c$ and both axes.

Write down the equation of the tangent to the circle

20. $x^2 + y^2 - 2x + 3y - 4 = 0$ at the point $(2, 1)$.

21. $x^2 + y^2 + 4x - 6y - 13 = 0$ at the point $(-3, -2)$.

22. Show that the lines $y = m(x - r) \pm r\sqrt{1 + m^2}$ touch the circle

$$x^2 + y^2 = 2rx,$$

whatever the value of m may be.

Find the equation of the tangent to the circle

23. $9(x^2 + y^2) - 9(6x - 8y) + 125 = 0$ parallel to $3x + 4y = 0$.

24. Show that the line $x - 2y = 0$ touches the circle

$$x^2 + y^2 - 4x + 8y = 0.$$

✗ 25. The line $y = 3x - 9$ touches the circle

$$x^2 + y^2 + 2x + 4y - 5 = 0.$$

Find the coordinates of the point of contact.

26. Find the equation of the tangent to $x^2 + y^2 = r^2$ (1) which is perpendicular to $y = mx + b$, (2) which passes through the point $(c, 0)$, (3) which makes with the axes a triangle whose area is r^2 .

Find the polar of the point

✗ 27. $(2, -\frac{1}{2})$ with respect to $x^2 + y^2 + 3x - 5y + 3 = 0$.

28. $(-a, b)$ with respect to $x^2 + y^2 - 2ax + 2by + a^2 - b^2 = 0$.

Find the pole of the line

✓ ✗ 29. $2x + 14y = 15$ with respect to $2(x^2 + y^2) - 3x + 5y - 2 = 0$.

30. $3(ax - by) = a^2 + b^2$ with respect to $x^2 + y^2 - 2ax + 2by = a^2 + b^2$.

✗ 31. Show that the circles $x^2 + y^2 - 4x + 2y = 15$ and $x^2 + y^2 = 5$ touch one another at the point $(-2, 1)$.

32. Show that the radical axis of two circles bisects their four common tangents.

33. The distances of two points from the centre of a circle are proportional to the distances of each from the polar of the other.

34. What is the analytic condition that the origin shall be the radical centre of three given circles?

35. Find the equation of the circle through the origin and the points of intersection of the circles

$$x^2 + y^2 - 5x - 7y + 6 = 0 \text{ and } x^2 + y^2 + 4x + 6y - 12 = 0.$$

What is the ratio of the tangents drawn from any point on it to the two given circles?

36. Find the equation of the circle which touches the line $4y = 3x$ and passes through the common points of

$$x^2 + y^2 = 9 \text{ and } x^2 + y^2 + x + 2y = 14.$$

37. What is the ratio of the tangents drawn from any point on the third circle in Ex. 11 to the other two circles?

38. Find the equations of the straight lines which touch both of the circles $x^2 + y^2 = 4$ and $(x - 4)^2 + y^2 = 1$. *Ans.* $3x \pm \sqrt{7}y = 8$ and $x \pm \sqrt{15}y = 8$.

39. Find the equations of the common tangents to the circles

$$x^2 + y^2 + 6y + 5 = 0 \text{ and } x^2 + y^2 - 12y + 20 = 0.$$

40. If the length of the tangent from the point (x', y') to the circle $x^2 + y^2 = 9$ is twice the length of the tangent from the same point to $x^2 + y^2 + 3x - 6y = 0$, show that

$$x'^2 + y'^2 + 4x' - 8y' + 3 = 0.$$

41. If the tangent from P to the circle $x^2 + y^2 + 3y = 0$ is four times as long as the tangent from P to the circle $x^2 + y^2 = 9$, show that the locus of P is

$$5(x^2 + y^2) = y + 48.$$

42. The length of a tangent drawn from a point P to the circle

$$x^2 + y^2 + 4x - 6y + 4 = 0$$

is three times the length of the tangent from P to the circle

$$x^2 + y^2 - 6x + 2y + 6 = 0.$$

Find the locus of P .

43. Find the locus of a point whose distance from the origin is equal to the length of the tangent drawn from it to the circle

$$x^2 + y^2 - 8x - 4y + 4 = 0.$$

44. Find the locus of a point P whose distance from a fixed point is in a constant ratio to the tangent drawn from P to a given circle. Under what condition is the locus a straight line?

45. Show that the polar of any point on the circle

$$x^2 + y^2 - 2ax - 3a^2 = 0,$$

with respect to the circle $x^2 + y^2 + 2ax - 3a^2 = 0$, will touch the parabola $y^2 + 4ax = 0$.

46. Show that the polars of the point $(1, 0)$ with respect to the two circles $x^2 + y^2 + 4x - 14 = 0$ and $x^2 + y^2 = 4$ are the same line; show that the same is true of the point $(4, 0)$.

47. Find two points such that the polars of each with respect to the two circles $x^2 + y^2 - 2x - 3 = 0$ and $x^2 + y^2 + 2x - 17 = 0$ coincide.

48. A certain point has the same polar with respect to two circles; prove that any common tangent subtends a right angle at that point. Show also that there are two such points for any two circles.

49. Find the locus of the intersection of two tangents to $x^2 + y^2 = r^2$ which are at right angles to one another.

50. Find the locus of the intersection of two tangents to $x^2 + y^2 = r^2$ which intersect at an angle α .

51. Show that if the coordinates of the extremities of a diameter of a circle are (x_1, y_1) and (x_2, y_2) , respectively, the equation of the circle will be

$$(x - x_1)(x - x_2) + (y - y_1)(y - y_2) = 0.$$

[*Suggestion.* Lines joining any point (x, y) on the circle to (x_1, y_1) and (x_2, y_2) are at right angles to one another.]

Find the equation of the circle which touches

52. the lines $x = 0$, $x = a$, and $3y = 4x + 3a$.

One Ans. $4(x^2 + y^2) - 4a(x + 5y) + 25a^2 = 0.$

53. both axes and the line $\frac{x}{a} + \frac{y}{b} = 1$.

54. Prove analytically that the locus of the middle points of a system of parallel chords of a circle is the diameter perpendicular to the chords. (See § 99.)

55. Show that as α varies the locus of the intersection of the lines

$$x \cos \alpha + y \sin \alpha = a \text{ and } x \sin \alpha - y \cos \alpha = b$$

is a circle.

56. A circle touches the y -axis and cuts off a constant length $(2a)$ from the x -axis; show that the locus of its centre is $x^2 - y^2 = a^2$.

57. Two lines are drawn through the points $(a, 0)$ and $(-\frac{a}{2}, 0)$ and make an angle α with one another. Show that the locus of their point of intersection is

$$x^2 + y^2 \pm 2ay \cot \alpha = a^2.$$

58. If the polar of the point (x', y') with respect to the circle $x^2 + y^2 = a^2$ touches the circle $x^2 + y^2 = 2ax$, show that $y'^2 + 2ax' = a^2$.

59. Show that if the axes are inclined at an angle ω , the equation of the circle is (§ 8)

$$(x - a)^2 + (y - b)^2 + 2(x - a)(y - b) \cos \omega = r^2,$$

where (a, b) is the centre and r the radius.

$$\frac{b^2 x^2 \pm a^2 y^2}{a^2 y^2} = \dots$$

CHAPTER X

THE ELLIPSE AND HYPERBOLA

107. *Standard equations of the tangent, polar, and normal to the ellipse and hyperbola.*

It has been shown in § 89 and § 90* that, if the axes of the curve are taken as coordinate axes, the equations of the *central conics* may be written in the standard form

$$\frac{x^2}{a^2} \pm \frac{y^2}{b^2} = 1. \dagger \tag{1}$$

Then the coordinates of the foci are $(\pm ae, 0)$; the equations of the directrices are $x = \pm \frac{a}{e}$; the length of the latus rectum is $\frac{2b^2}{a}$; and $e = \frac{\sqrt{a^2 \mp b^2}}{a}$.

For equation (1) formula (6), § 92, gives

$$\frac{xx'}{a^2} \pm \frac{yy'}{b^2} = 1. \tag{2}$$

Equation (2) is the equation of the polar (§ 94) of the point (x', y') with respect to the central conic (1), which polar is a tangent at the point (x', y') when (x', y') is on the conic.

The equation of the normal at any point (x', y') on the conic (1) is

$$y - y' = \frac{a^2 y'}{\pm b^2 x'} (x - x'), \text{ or } \frac{x - x'}{a^2} = \frac{y - y'}{\pm b^2}. \quad [(2), \text{ § 62.}] \tag{3}$$

Ex. 1. Find the equations of the central conics when the origin is at either focus; at either vertex; at the point (h, k) , the coordinate axes being parallel to the axes of the conic.

Ex. 2. What relation does the line (3) have to the conic when (x', y') is not on the curve?

* These sections should now be carefully reviewed.

† We shall use this form of the equation, although the simpler form $ax^2 + by^2 = 1$ is sometimes more convenient. When the double sign \pm or \mp is prefixed to b^2 , the upper sign holds for the ellipse and the lower for the hyperbola. All results are true for both curves unless the contrary is expressly stated. Furthermore, results for the ellipse include those for the circle as the special case when $a = b$.

108. To find the equation of the tangent to the conic

$$\frac{x^2}{a^2} \pm \frac{y^2}{b^2} = 1 \quad (1)$$

in terms of its slope m .

Assume the equation of the tangent to be

$$y = mx + c, \quad (2)$$

where m is known, and c is to be determined so that (1) and (2) shall intersect in two coincident points (§ 57).

Eliminating y between (1) and (2) gives

$$\frac{x^2}{a^2} \pm \frac{(mx + c)^2}{b^2} = 1,$$

$$\text{or} \quad x^2(a^2m^2 \pm b^2) + 2a^2cmx + a^2(c^2 \mp b^2) = 0. \quad (3)$$

The roots of equation (3) will be equal if

$$a^2(c^2 \mp b^2)(a^2m^2 \pm b^2) = a^4c^2m^2.$$

Whence

$$c^2 = a^2m^2 \pm b^2. \quad (4)$$

That is, the points of intersection of the straight line and the conic will coincide if

$$c = \pm \sqrt{a^2m^2 \pm b^2}. \quad (5)$$

Hence the line whose equation is

$$y = mx \pm \sqrt{a^2m^2 \pm b^2}, \quad (6)$$

will touch the conic (1) for all values of m .

The double sign before the radical in (6) shows that there are two tangents for every value of m ; i.e. there are two tangents to a central conic parallel to any given straight line; and these two parallel tangents are equidistant from the centre of the conic.

Ex. 1. Derive equation (6) by the method used in § 98.

Ex. 2. In a similar manner show that the equation of the normal to (1) expressed in terms of its slope is

$$y = mx - \frac{m(a^2 \mp b^2)}{\sqrt{a^2 \pm b^2m^2}}.$$

Ex. 3. How many normals can be drawn from a given point to a central conic?

109. Geometric properties of the ellipse and hyperbola.

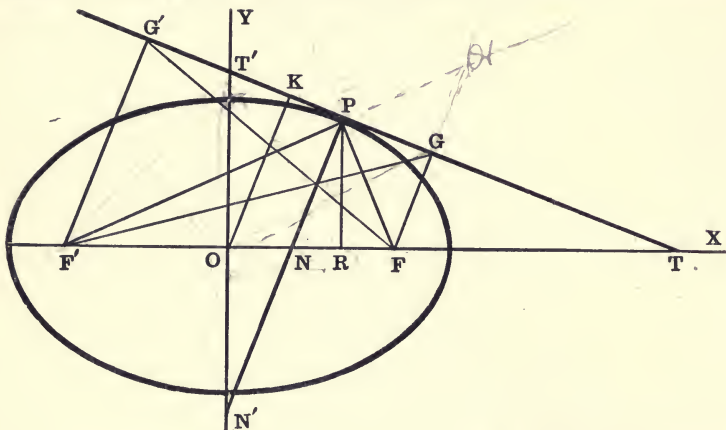

Let the tangent at $P(x', y')$ meet the axes in T and T' ; let the normal at P meet the axes in N and N' ; let RP be the ordinate of P and F, F' the foci of the conic.

Draw $FG, F'G'$, and OK perpendicular to the tangent PT .

Then $OT = \frac{a^2}{x'}$, $OT' = \frac{\pm b^2}{y'}$. [(2), § 107.] (1)

\therefore Subtangent $= TR = \frac{a^2 - x'^2}{x'} = y' \div \frac{dy'}{dx'}$. (2)

$ON = e^2 x'$, $ON' = \frac{e^2}{e^2 - 1} y'$. [(3), § 107.] (3)

\therefore Subnormal $= RN = (e^2 - 1)x' = y' \frac{dy'}{dx'}$. (4)

$OK \cdot NP = FG \cdot F'G' = \pm b^2$. (5)

$ON \cdot OT = a^2 e^2 = OF^2$. From (1) & (2) (6)

$PN \cdot PN' = FP \cdot F'P = \pm (a^2 - e^2 x'^2)$. (§§ 89, 90.) (7)

$F'G$ and FG' bisect PN . (8)

The locus of G and G' is $x^2 + y^2 = a^2$. [Use (6), § 108.] (9)

$$\frac{F'N}{NF} = \frac{F'O + ON}{OF - ON} = \frac{ae + e^2 x'}{ae - e^2 x'} = \frac{a + ex'}{a - ex'}$$

$\therefore \frac{F'N}{NF} = \frac{F'P}{\pm FP}$ (§§ 89, 90.) (10)

Therefore the tangent and the normal bisect the angles between the focal radii FP and $F'P$.

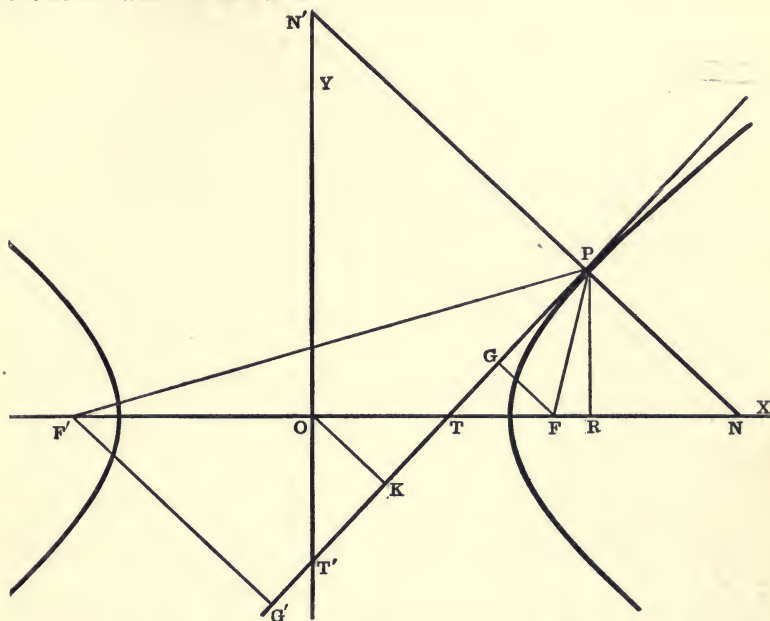

Hence, if an ellipse and a hyperbola have the same foci, the *tangent* and the *normal* to one of the curves at any one of their four common points are, respectively, the *normal* and the *tangent* to the other. That is, the two conics intersect orthogonally.

Conics having the same foci are called **Confocal Conics**.

Ex. 1. Explain what would happen if a light were placed at one focus of an ellipse; a hyperbola.

Ex. 2. What is the limit of ON , ON' , and RN as $x' = a$? as $x' = 0$?

Ex. 3. Show that equations (1), (3), and $OK \cdot NP = b^2$ are also true when P is any point, TT' the polar of P , and PN is perpendicular to TT' .

Ex. 4. Show that the equation $\frac{x^2}{a^2 + \lambda} + \frac{y^2}{b^2 + \lambda} = 1$ represents a system of *confocal conics*, where λ is the arbitrary parameter. Investigate the nature of these conics for values of λ ranging from $-\infty$ to $+\infty$. Show that two confocals, an ellipse and a hyperbola, pass through every point in the plane, and that these meet at right angles.

EXAMPLES

Find the eccentricity, foci, and latus rectum of each of the following conics :

1. $x^2 + 2y^2 = 4$.

2. $4x^2 - 9y^2 = 36$.

3. $4x^2 + y^2 = 8$.

4. $3x^2 - y^2 = 9$.

5. $3(x-1)^2 + 4(y+2)^2 = 1$.

6. $3(y-1)^2 - 4(x+1)^2 = 1$.

Find the equation of an ellipse referred to its axes

7. if the latus rectum is 6 and the eccentricity $\frac{1}{2}$.

8. if the latus rectum is 4 and the minor axis is equal to the distance between the foci.

9. Find the equation of the hyperbola whose foci are the points $(\pm 4, 0)$ and whose eccentricity is $\sqrt{2}$.

10. Find the eccentricity and the equation of the ellipse, if the latus rectum is equal to half the minor axis.

11. Find the equation of the hyperbola with eccentricity 2 which passes through $(-4, 6)$.

12. Find the equation of the ellipse passing through the points $(-2, 2)$ and $(3, -1)$; also the equation of the hyperbola through $(1, -3)$ and $(2, 4)$.

Through how many points can a central conic be made to pass if its axes are given? Why?

13. Find the eccentricity and the equation of a central conic if the foci lie midway between the centre and the vertices; if the vertices lie midway between the centre and the foci.

14. Show that the tangents at the ends of either axis of a central conic are parallel to the other axis; and also that tangents at the ends of any chord through the centre are parallel.

15. Find the equations of the tangents and normals at the ends of the latera recta. Where do they meet the x -axis? *One Ans. $y + ex = a$.*

16. Show that the line $y = 2x - \sqrt{\frac{7}{3}}$ touches the conic

$$3x^2 - 6y^2 = 1.$$

17. Find the equations of the tangents to the ellipse $x^2 + 4y^2 = 16$ which make angles of 45° and 60° with the x -axis.

18. Show that the directrix is the polar of the focus.

19. If the slope of a moving line remains constant, the locus of its pole with respect to a central conic is a straight line through the centre of the conic.

110. *Conjugate Hyperbolas.*

The two hyperbolas whose equations are

$$\frac{x^2}{a^2} - \frac{y^2}{b^2} = 1, \quad (1)$$

$$\text{and } \left. \begin{array}{l} \frac{x^2}{a^2} - \frac{y^2}{b^2} = -1, \\ \text{or } \frac{y^2}{b^2} - \frac{x^2}{a^2} = 1, \end{array} \right\} \quad (2)$$

are so related that the transverse axis of the one is the conjugate axis of the other.

The two hyperbolas are then said to be **conjugate** to one another.

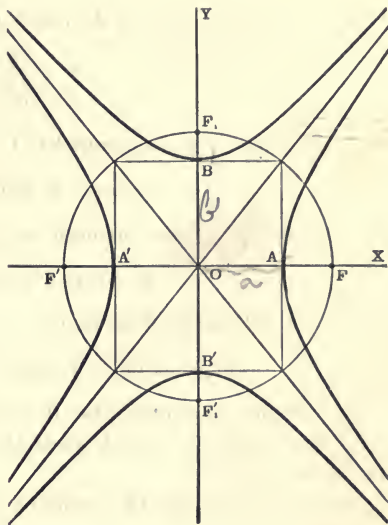

The eccentricity of the *Conjugate Hyperbola** is $e_1 = \frac{\sqrt{b^2 + a^2}}{b}$; the coordinates of its foci are $(0, \pm be_1)$; the equations of its directrices are $y = \pm \frac{b}{e_1}$; and its latus rectum is $\frac{2a^2}{b}$.

When $a = b$, equations (1) and (2) become, respectively,

$$\text{and } \left. \begin{array}{l} x^2 - y^2 = a^2, \\ y^2 - x^2 = a^2. \end{array} \right\} \quad (3)$$

Hence if a hyperbola is equilateral or rectangular [§ 90, (15)], its conjugate is also rectangular.

Two conjugate hyperbolas are not, in general, similar (§ 116), *i.e.* of the same shape, but two conjugate rectangular hyperbolas are equal.

* The hyperbola (2) is usually called the *Conjugate Hyperbola*, while (1) is called the *Original*, or *Primary Hyperbola*. It is to be noticed that the equation of the conjugate hyperbola is found by *changing the sign of one member of the equation of the primary hyperbola*. Likewise the equation of the conjugate ellipse is found to be

$$\frac{x^2}{a^2} + \frac{y^2}{b^2} = -1.$$

Hence the conjugate of an ellipse is imaginary.

111. To find the locus of the point of intersection of two perpendicular tangents to the conic

$$\frac{x^2}{a^2} \pm \frac{y^2}{b^2} = 1. \quad (1)$$

The equation of any tangent to (1) may be written (§ 108)

$$y = mx + \sqrt{a^2 m^2 \pm b^2}. \quad (2)$$

If this line (2) passes through (x_1, y_1) , we shall have

$$y_1 = mx_1 + \sqrt{a^2 m^2 \pm b^2},$$

which when rationalized becomes

$$(x_1^2 - a^2)m^2 - 2x_1 y_1 m + (y_1^2 \mp b^2) = 0. \quad (3)$$

This equation is a quadratic in m whose two roots are the slopes of the two tangents which pass through the point (x_1, y_1) , whose locus is required.

Let m_1 and m_2 be the two roots of (3); then (§ 68)

$$m_1 m_2 = \frac{y_1^2 \mp b^2}{x_1^2 - a^2}.$$

The two tangents will be at right angles if $m_1 m_2 = -1$ (§ 45); i.e. if

$$\frac{y_1^2 \mp b^2}{x_1^2 - a^2} = -1,$$

or

$$x_1^2 + y_1^2 = a^2 \pm b^2. \quad (4)$$

The required locus is, therefore, the circle

$$x^2 + y^2 = a^2 \pm b^2, \quad (5)$$

which is called the **Director Circle** of the conic.

COR. I. If $a < b$, the director circle of a hyperbola is imaginary.

Hence one of the director circles of two conjugate hyperbolas is always imaginary.

COR. II. The director circle of the ellipse $\frac{x^2}{a^2} + \frac{y^2}{b^2} = 1$ passes through the foci of the hyperbolas $\frac{x^2}{a^2} - \frac{y^2}{b^2} = \pm 1$, and vice versa.

What does this mean when $a = b$?

112. *Auxiliary Circle, and Eccentric Angle.*

I. The circle described on the major axis of an ellipse as diameter is called the **Auxiliary Circle**.

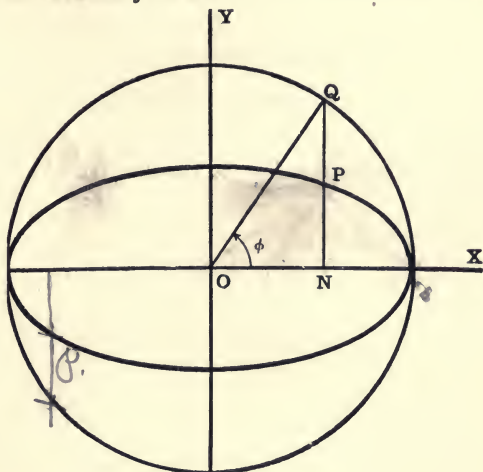

If the equation of the ellipse is

$$\frac{x^2}{a^2} + \frac{y^2}{b^2} = 1, \quad (1)$$

the equation of the auxiliary circle will be

$$x^2 + y^2 = a^2. \quad (2)$$

If the ordinate NP of any point P on the ellipse is produced to meet the auxiliary circle in Q , then P and Q are called **Corresponding Points**.

Let $P(x_1, y_1)$ and $Q(x_1, y_2)$ be any two corresponding points; then, since these points are on (1) and (2), respectively,

$$y_1 = \frac{b}{a} \sqrt{a^2 - x_1^2}, \quad (3)$$

and

$$y_2 = \sqrt{a^2 - x_1^2}. \quad (4)$$

$$\therefore \frac{y_1}{y_2} = \frac{b}{a}. \quad (5)$$

That is, the ordinates of corresponding points are in a constant ratio.

Ex. Show that the area of the ellipse is πab .

The angle XOQ is called the **Eccentric Angle** of the point P . It will be denoted by ϕ .

Then the coordinates of the point Q are

$$x_1 = a \cos \phi, \quad y_1 = a \sin \phi.$$

Since $y_1 = \frac{b}{a} x_1$, $y_2 = b \sin \phi$, the coordinates of P are

$$x_1 = a \cos \phi, \quad y_1 = b \sin \phi. \quad (6)$$

II. The circle described on the transverse axis of a hyperbola as diameter may be called the *Auxiliary Circle* of the hyperbola.

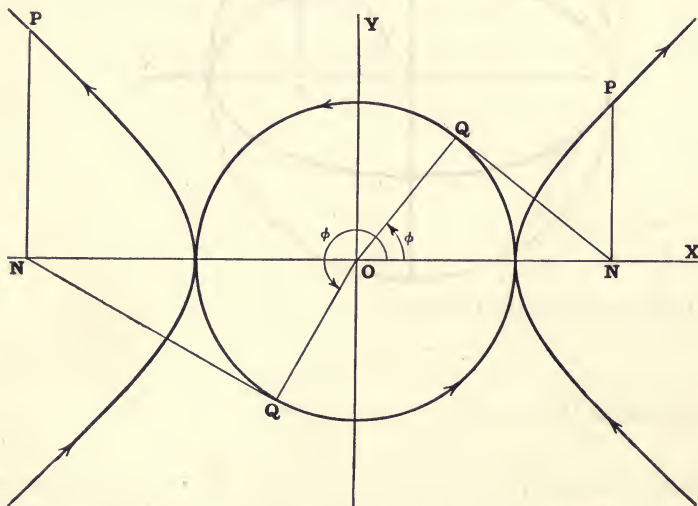

Let $P(x, y)$ be any point on the hyperbola and NP its ordinate. Draw NQ tangent to the auxiliary circle at Q , so that P and Q are on the same side of the transverse axis when P is on the right branch, and on opposite sides when P is on the left branch of the curve. Then, as P describes the complete hyperbola in the direction indicated by the arrows, Q will move consecutively around the circle in the direction indicated. Thus, for every position of P on the hyperbola, there is one and only one corresponding position of Q on the circle.

Hence P and Q may be called *Corresponding Points*, and the angle $XOQ \equiv \phi$ may be called the *Eccentric Angle* of the point P .

Let the equation of the hyperbola be

$$\frac{x^2}{a^2} - \frac{y^2}{b^2} = 1. \quad (7)$$

Then

$$ON = x = a \sec \phi, \quad (8)$$

which substituted in (7) gives

$$y = b \tan \phi. \quad (9)$$

That is, P is the point $(a \sec \phi, b \tan \phi)$.

Similarly, $x^2 + y^2 = b^2$ is the auxiliary circle of the conjugate hyperbola, and $(a \tan \phi, b \sec \phi)$ is any point on the curve if ϕ is measured *clockwise* from the positive end of the y -axis; if ϕ is measured from the x -axis the point is $(a \cot \phi, b \csc \phi)$.

113. To find the equation of the straight line joining two points on a conic whose eccentric angles are ϕ and ϕ' .

If the conic is an ellipse, the points are (§ 112)

$$(a \cos \phi, b \sin \phi) \quad \text{and} \quad (a \cos \phi', b \sin \phi').$$

The equation of the line through these points is [(3), § 44]

$$\frac{x - a \cos \phi}{a \cos \phi - a \cos \phi'} = \frac{y - b \sin \phi}{b \sin \phi - b \sin \phi'}. \quad (1)$$

Since $\cos \phi - \cos \phi' = -2 \sin \frac{1}{2}(\phi + \phi') \sin \frac{1}{2}(\phi - \phi')$
and $\sin \phi - \sin \phi' = 2 \cos \frac{1}{2}(\phi + \phi') \sin \frac{1}{2}(\phi - \phi')$,
equation (1) reduces to

$$\frac{\frac{x}{a} - \cos \phi}{-2 \sin \frac{1}{2}(\phi + \phi')} = \frac{\frac{y}{b} - \sin \phi}{2 \cos \frac{1}{2}(\phi + \phi')} \quad (2)$$

$$\therefore \frac{x}{a} \cos \frac{1}{2}(\phi + \phi') + \frac{y}{b} \sin \frac{1}{2}(\phi + \phi') = \cos \frac{1}{2}(\phi - \phi'), \quad (3)$$

which is the required equation.

In like manner the equation of the line joining the points $(a \sec \phi, b \tan \phi)$ and $(a \sec \phi', b \tan \phi')$ on the hyperbola can be shown to be

$$\frac{x}{a} \cos \frac{1}{2}(\phi - \phi') - \frac{y}{b} \sin \frac{1}{2}(\phi + \phi') = \cos \frac{1}{2}(\phi + \phi'). \quad (4)$$

To find the equation of the tangent at the point ϕ , we put $\phi' = \phi$ in equations (3) and (4), and we obtain for the ellipse

$$\frac{x}{a} \cos \phi + \frac{y}{b} \sin \phi = 1, \quad (5)$$

and for the hyperbola

$$\frac{x}{a} \sec \phi - \frac{y}{b} \tan \phi = 1. \quad (6)$$

From equation (3) we see that if the sum of the eccentric angles of two points on an ellipse is constant and equal to 2α , the equation of the line joining them is

$$\frac{x}{a} \cos \alpha + \frac{y}{b} \sin \alpha = \cos \frac{1}{2}(\phi - \phi'). \quad (7)$$

Hence the chord is always parallel to the tangent

$$\frac{x}{a} \cos \alpha + \frac{y}{b} \sin \alpha = 1. \quad (8)$$

Conversely, in a system of parallel chords of an ellipse, the sum of the eccentric angles of the extremities of any chord is constant.

Similarly from equation (4) we see that if the sum of the eccentric angles of two points on a hyperbola is constant and equal to 2α , the equation of the chord through these points is

$$\frac{x}{a} \cos \frac{1}{2}(\phi - \phi') - \frac{y}{b} \sin \alpha = \cos \alpha, \quad (9)$$

and therefore the chord, and the tangent at the point α , viz.,

$$\frac{x}{a} - \frac{y}{b} \sin \alpha = \cos \alpha, \quad (10)$$

always meet the y -axis in the same fixed point.

114. *To find the equation of the normal at any point in terms of the eccentric angle of the point.*

Let $(a \cos \phi, b \sin \phi)$ (§ 112) be any point on the ellipse; then the slope of the tangent at the point ϕ is $-\frac{b \cos \phi}{a \sin \phi}$. [§ 113, (5).]

Hence the equation of the normal at ϕ is [(2), § 62]

$$y - b \sin \phi = \frac{a \sin \phi}{b \cos \phi} (x - a \cos \phi), \quad (1)$$

or

$$\frac{ax}{\cos \phi} - \frac{by}{\sin \phi} = a^2 - b^2. \quad (2)$$

Similarly we find the equation of the normal to the hyperbola at the point $(a \sec \phi, b \tan \phi)$ to be

$$\frac{ax}{\sec \phi} + \frac{by}{\tan \phi} = a^2 + b^2. \quad (3)$$

EXAMPLES

1. The point $P(-3, -1)$ is on the ellipse $x^2 + 3y^2 = 12$; find the corresponding point on the auxiliary circle, and the eccentric angle of P .

2. An ellipse slides between two perpendicular lines; show that the locus of the centre is a circle. (§ 111.)

3. Show that, for all values of b , tangents to the ellipse $\frac{x^2}{a^2} + \frac{y^2}{b^2} = 1$ at points having the same abscissa meet the x -axis in the same point. Hence show how a tangent can be drawn to an ellipse from any point on the x -axis.

4. Two tangents are drawn to a conic from any point on the director circle; prove that the sum of the squares of the chords which the auxiliary circle intercepts on them is equal to the square of the line joining the foci. (See (9), § 109.)

5. If the points Q and Q' are taken on the minor axis of a conic such that $QO = OQ' = OF$, where O is the centre and F a focus, show that the sum of the squares of the perpendiculars from Q and Q' on any tangent to the conic is constant.

6. A line is drawn through the centre of a conic parallel to the focal radius of a point P and meeting the tangent at P in Q . Find the locus of Q . 109

7. From one focus of an ellipse a perpendicular is drawn to any tangent and produced to an equal distance on the other side. Show that its terminus Q is in the straight line through the other focus and the point of tangency. Also find the locus of Q .

8. Show that the locus of the point of intersection of tangents to an ellipse at two points whose eccentric angles differ by a constant is an ellipse.

[If the tangents at $\phi + \alpha$ and $\phi - \alpha$ meet at (x', y') , then $\frac{x'}{a} = \cos \phi \sec \alpha$, $\frac{y'}{b} = \sin \phi \sec \alpha$. Eliminate ϕ for the locus.]

What is the corresponding theorem for the hyperbola ?

115. DEF. An **Asymptote*** to a curve is the limiting position of the tangent line as the point of contact moves off to an infinite distance, while the line itself remains at a finite distance from the origin.

To find the asymptotes of the hyperbola.

$$\frac{x^2}{a^2} - \frac{y^2}{b^2} = 1. \quad (1)$$

As in § 108, the abscissas of the points where the line

$$y = mx + c \quad (2)$$

meets the hyperbola are given by the equation

$$x^2(a^2m^2 - b^2) + 2a^2cmx + a^2(c^2 + b^2) = 0. \quad (3)$$

If the line (2) becomes an asymptote, both roots of equation (3) must become infinite. Hence the coefficients of x^2 and x must both approach zero (§ 77). That is,

$$a^2cm \doteq 0, \quad \text{and} \quad a^2m^2 - b^2 \doteq 0. \\ \therefore \lim c = 0, \quad \text{and} \quad \lim m = \pm \frac{b}{a}. \quad (4)$$

Substituting these limiting values in (2), we have for the required equations of the asymptotes

$$y = \pm \frac{b}{a}x, \quad \text{Squaring } \approx \quad (5)$$

or expressed in one equation

$$\frac{x^2}{a^2} - \frac{y^2}{b^2} = 0. \quad (6)$$

Therefore the hyperbola has two asymptotes, both passing through the centre and equally inclined to the transverse axis.

The equations of the asymptotes to a hyperbola can also be found by considering the limiting form of the equation of the tangent as the point of contact moves off to an infinite distance.

The equation of the tangent to (1) at (x', y') is

$$\frac{xx'}{a^2} - \frac{yy'}{b^2} = 1. \quad (7)$$

* Greek, ἀσύνπτωτος, not falling together.

Since the point (x', y') is on the conic (1), we have

$$y' = \pm \frac{b}{a} \sqrt{x'^2 - a^2}.$$

Hence quotation (7) may be written

$$\frac{x}{a^2} \pm \frac{y}{ab} \sqrt{1 - \frac{a^2}{x'^2}} = \frac{1}{x'}.$$

Handwritten note: $\frac{1}{\cancel{a}} = 0$, $\frac{a^2}{\cancel{a^2}} = 0$ (8)

If now the point of contact (x', y') moves off to an infinite distance so that x' becomes infinite, the limiting position of the line (8) is given by the equation

$$\frac{x}{a} \pm \frac{y}{b} = 0, \quad (9)$$

which is the same as equation (5) above.

COR. I. *Two conjugate hyperbolas have the same asymptotes, which are the diagonals of the rectangle formed by the tangents at their vertices.*

COR. II. *A straight line parallel to an asymptote will meet the conic in one point at infinity.*

For, if c is not zero, only one root of (3) is infinite.

COR. III. *The line $y = mx$ will cut the hyperbola in real or imaginary points according as $m < \text{or} > \frac{b}{a}$. It will meet either the hyperbola or its conjugate in real points for all values of m .*

COR. IV. *The asymptotes of an ellipse are imaginary.*

For, if we change the sign of b^2 , the values of m for infinite roots in (3) become imaginary.

It is to be noticed that the equations of two conjugate hyperbolas and the equation of their common asymptotes, viz.,

$$\frac{x^2}{a^2} - \frac{y^2}{b^2} = \pm 1 \quad \text{and} \quad \frac{x^2}{a^2} - \frac{y^2}{b^2} = 0,$$

differ only in their constant terms. Moreover, this must always be true; for any transformation of coordinates will affect the first members of these equations in precisely the same way. Hence the new equations will differ only in their constant terms (not usually by unity); and the value of the constant in the equation of the asymptotes will be equal to half the sum of the constants in the equations of the two hyperbolas.

116. *Similar and Coaxial Conics.*

Since $a\sqrt{K}$ and $b\sqrt{K}$ are the semi-axes of the ellipse

$$\frac{x^2}{a^2} + \frac{y^2}{b^2} = K, \quad (1)$$

its eccentricity is given by the equation

$$e = \frac{\sqrt{a^2K - b^2K}}{a\sqrt{K}} = \frac{\sqrt{a^2 - b^2}}{a}. \quad (\S 107.)$$

That is, the eccentricity of (1) is the same as the eccentricity of the ellipse represented by the standard equation

$$\frac{x^2}{a^2} + \frac{y^2}{b^2} = 1. \quad (2)$$

Two conics having the same eccentricity are said to be *similar*; for one is then merely a magnification of the other.

Conics having their axes on the same lines are said to be *Coaxial*.

Hence if K is an arbitrary parameter, (1) will represent a system of similar and coaxial ellipses.

For any particular value of K the equations

$$\frac{x^2}{a^2} - \frac{y^2}{b^2} = \pm K \quad (3)$$

represent a pair of conjugate hyperbolas (§ 110).

If, however, K is arbitrary, equations (3) will give (as in the case of the ellipse) a system of similar and coaxial hyperbolas, together with their corresponding conjugate hyperbolas, which are also similar. It follows from § 115 that these two infinite systems of hyperbolas all have the same asymptotes. Moreover, the asymptotes are the limit which both systems approach as K becomes zero. Thus two intersecting lines are not only one of a system of similar and coaxial hyperbolas, but may also be regarded as a pair of *self-conjugate hyperbolas*.

It is also to be noticed that although both axes of two intersecting lines are zero, the limit of their ratio as they approach zero is the tangent of half the angle between the lines.

COR. *The axes of similar conics are proportional.*

117. To find the locus of the middle points of a system of parallel chords of a central conic.

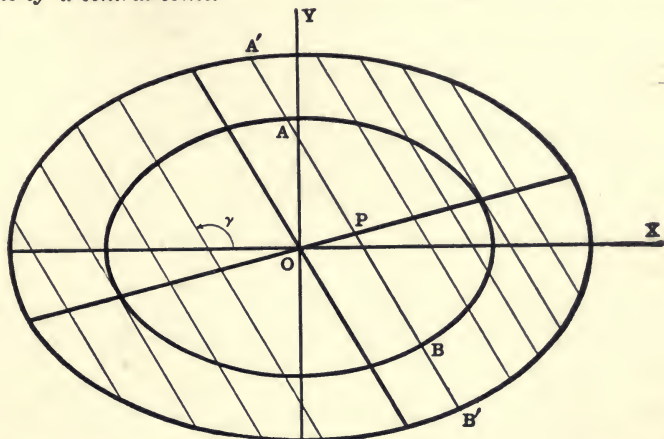

I. Let AB be any one of a system of parallel chords of the ellipse

$$\frac{x^2}{a^2} + \frac{y^2}{b^2} = K. \quad (1)$$

Let $P(x', y')$ be the middle point of AB , and γ its inclination to the x -axis.

Then the equation of AB may be written [§ 43, (4)]

$$\frac{x - x'}{\cos \gamma} = \frac{y - y'}{\sin \gamma} = r,$$

or
$$x = x' + r \cos \gamma, \quad y = y' + r \sin \gamma, \quad (2)$$

where r is the distance from (x', y') to any point (x, y) on the line.

If the point (x, y) is on the ellipse, these values (2) may be substituted in equation (1); this gives

$$\frac{(x' + r \cos \gamma)^2}{a^2} + \frac{(y' + r \sin \gamma)^2}{b^2} = K, \text{ or}$$

$$\left(\frac{\cos^2 \gamma}{a^2} + \frac{\sin^2 \gamma}{b^2}\right)r^2 + 2\left(\frac{x' \cos \gamma}{a^2} + \frac{y' \sin \gamma}{b^2}\right)r + \frac{x'^2}{a^2} + \frac{y'^2}{b^2} - K = 0. \quad (3)$$

The values of r found by solving this quadratic equation are the lengths of the lines PA and PB , which can be drawn from P

along AB to the ellipse. Since P is the *middle* point of the chord, these two values of r must be *equal in magnitude and opposite in sign*; i.e. the sum of the roots of (3) must be zero. Hence (§ 68)

$$\frac{x' \cos \gamma}{a^2} + \frac{y' \sin \gamma}{b^2} = 0. \quad (4)$$

The required locus is, therefore, the straight line

$$y = -\frac{b^2}{a^2} \cot \gamma \cdot x. \quad (5)$$

Hence every *diameter* (§ 99) of an ellipse passes through the centre.

COR. I. *All chords intercepted on the same line, or on a series of parallel lines, by a system of similar and coaxial ellipses are bisected by the same diameter.*

Since equation (5) is independent of K , the locus of P is the same whatever value may be given to K in (1). (§ 116.)

COR. II. *If a straight line meets each of two similar and coaxial ellipses in two real points, the two portions of the line intercepted between them are equal; i.e. $A'A = BB'$.*

COR. III. *Chords of an ellipse which are tangent to a similar and coaxial ellipse are bisected at the point of contact.*

COR. IV. *The tangent at either extremity of any diameter is parallel to the chords bisected by that diameter.*

II. In like manner, if γ is the inclination to the x -axis of a system of parallel chords of the hyperbolas

$$\frac{x^2}{a^2} - \frac{y^2}{b^2} = \pm K, \quad (6)$$

we find the locus of the middle points of the chords to be the straight line

$$y = \frac{b^2}{a^2} \cot \gamma \cdot x, \quad (7)$$

for all values of K , including the case $K = 0$.

Hence all diameters of a hyperbola pass through the centre.

The preceding corollaries apply also to similar and coaxial hyperbolas.

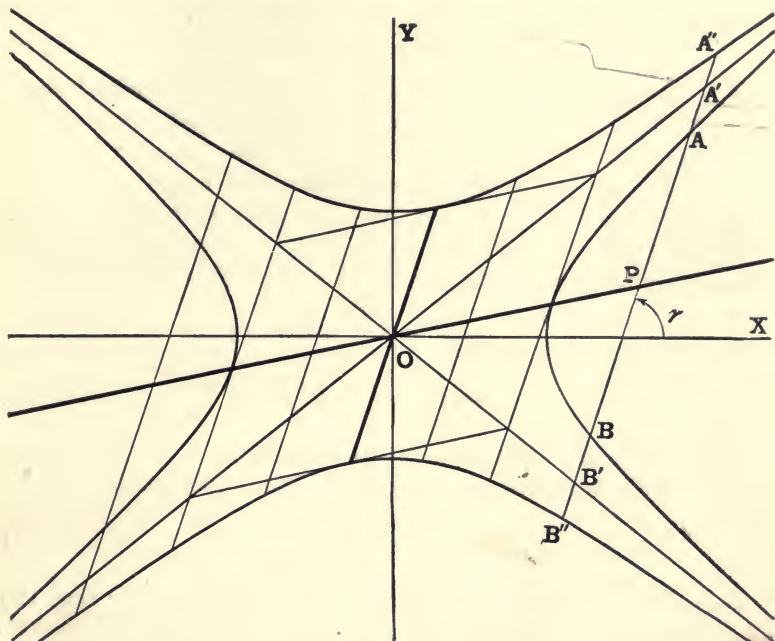

COR. V. Chords intercepted on the same line, or on a system of parallel lines, by two conjugate hyperbolas, and their asymptotes, are bisected by the same diameter.

COR. VI. If a straight line meets each of two conjugate hyperbolas in real points, the two portions of the line intercepted between the curves are equal. The portions intercepted between either hyperbola and the asymptotes are also equal; i.e. $A''A = BB''$ and $A'A = BB'$. Hence the part of a tangent to a hyperbola included between the two branches of its conjugate, and also the part included between its asymptotes, are bisected at the point of contact.

Ex. 1. Find the locus of the middle points of chords of the ellipse $4x^2 + 9y^2 = 36$ parallel to $3x - 2y = 1$.

Ex. 2. Find the equation of the chord of the hyperbola $25x^2 - 16y^2 = 400$ which is bisected at the point $(2, -5)$.

Ex. 3. Find the equation of the chord of the ellipse $4x^2 + 8y^2 = 32$ which is bisected at the point $(-2, 1)$.

CONJUGATE DIAMETERS

118. We have seen in § 117 that all diameters of a central conic pass through the centre. Conversely, *every chord which passes through the centre is a diameter, i.e. bisects some system of parallel chords.* For, by giving γ a suitable value, equations (5) and (7) of § 117 may be made to represent any chord through the centre.

If γ' is the inclination to the x -axis of the diameter which bisects all chords whose inclination is γ , we have, from (5) and (7) of § 117,

$$\tan \gamma' = \mp \frac{b^2}{a^2} \cot \gamma,$$

or
$$\tan \gamma \tan \gamma' = \mp \frac{b^2}{a^2}. \quad (1)$$

Let $y = mx$ and $y = m'x$ be any two diameters.

Then, if the first bisects all chords parallel to the second, we have from (1)

$$mm' = \mp \frac{b^2}{a^2}. \quad (2)$$

Since this is the only condition that must hold in order that the second may bisect all chords parallel to the first, it follows that, *if one diameter of a conic bisects all chords parallel to a second, the second diameter will also bisect all chords parallel to the first.*

DEF. Two diameters, so related that each bisects every chord parallel to the other, are called **Conjugate Diameters**.*

For example, the axes are a pair of conjugate diameters.

From equation (2) we see that the slopes of two conjugate diameters of an ellipse have *opposite* signs, whereas in the hyperbola the signs are the *same*. (See figures under § 117.)

If $m < \frac{b}{a}$, then $m' > \frac{b}{a}$, numerically.

Hence conjugate diameters of an ellipse are separated by the axes, and also by the lines $ay = \pm bx$; while conjugate diameters of a hyperbola are separated by the asymptotes, but not by the axes.

* It is evident that none but central conics can have conjugate diameters, since in the parabola all diameters have the same direction (§ 99).

119. Given the extremity of any diameter, to find the extremities of the conjugate diameter.

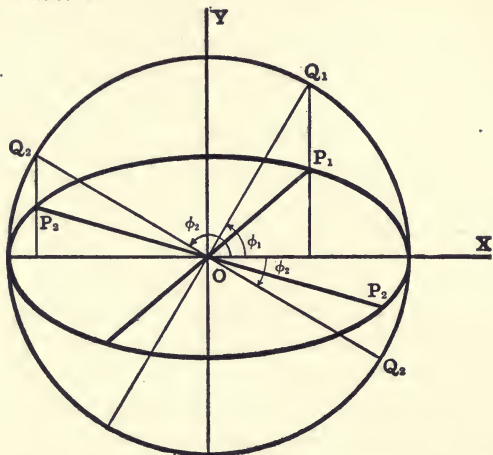

I. Let $P_1(x_1, y_1)$, $P_2(x_2, y_2)$ be the extremities of two conjugate diameters of an ellipse.

Then the equations of OP_1 and OP_2 are

$$y = \frac{y_1}{x_1}x \text{ and } y = \frac{y_2}{x_2}x.$$

$$\therefore \frac{y_1 y_2}{x_1 x_2} = -\frac{b^2}{a^2}, \quad [(1), \text{§ 118.}]$$

or

$$\frac{x_1 x_2}{a^2} + \frac{y_1 y_2}{b^2} = 0. \quad (1)$$

Let ϕ_1, ϕ_2 be the eccentric angles of P_1, P_2 , respectively.

Then

$$x_1 = a \cos \phi_1, \quad y_1 = b \sin \phi_1,$$

$$x_2 = a \cos \phi_2, \quad y_2 = b \sin \phi_2. \quad (\text{§ 112, I.})$$

Substituting these values in (1), we have

$$\cos \phi_1 \cos \phi_2 + \sin \phi_1 \sin \phi_2 \equiv \cos(\phi_1 - \phi_2) = 0. \quad (2)$$

$$\therefore \phi_1 - \phi_2 = 90^\circ.$$

That is, the eccentric angles of the extremities of two conjugate diameters of an ellipse differ by a right angle. Hence the corresponding diameters OQ_1, OQ_2 of the auxiliary circle are perpendicular to one another.

Since

$$\phi_2 = \phi_1 \pm 90^\circ,$$

$$\sin \phi_2 = \pm \cos \phi_1, \quad \cos \phi_2 = \mp \sin \phi_1.$$

Therefore the extremities of two conjugate diameters of an ellipse may be written

$$\left. \begin{aligned} &P_1(a \cos \phi_1, b \sin \phi_1) \text{ and } P_2(\mp a \sin \phi_1, \pm b \cos \phi_1), \\ \text{or} &P_1(x_1, y_1) \text{ and } P_2\left(\mp \frac{a}{b}y_1, \pm \frac{b}{a}x_1\right). \end{aligned} \right\} \quad (3)$$

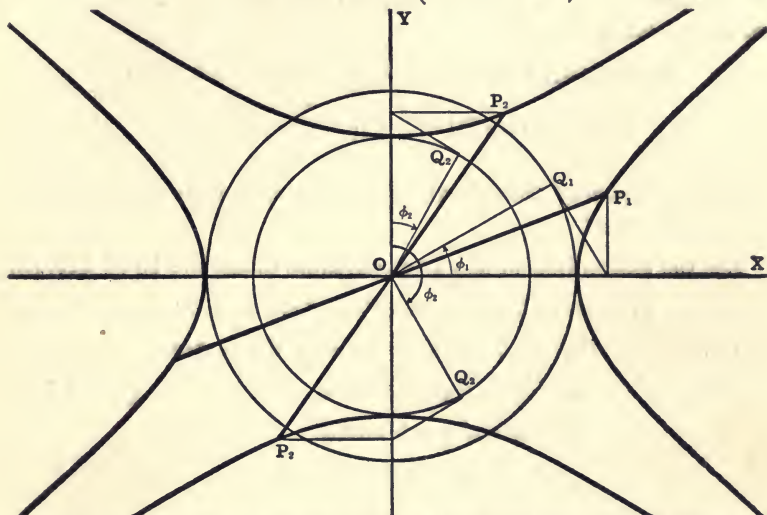

II. If P_1, P_2 are the extremities of two conjugate diameters of a hyperbola, equation (1) becomes

$$\frac{x_1 x_2}{a^2} - \frac{y_1 y_2}{b^2} = 0. \quad (4)$$

Then from § 112, II, and § 118, Cor. II, we also have

$$x_1 = a \sec \phi_1, \quad y_1 = b \tan \phi_1,$$

$$x_2 = a \tan \phi_2, \quad y_2 = b \sec \phi_2.$$

Substituting these values in (4) gives

$$\sec \phi_1 \tan \phi_2 - \tan \phi_1 \sec \phi_2 = 0, \quad (5)$$

or

$$\frac{\sin \phi_2}{\cos \phi_1 \cos \phi_2} - \frac{\sin \phi_1}{\cos \phi_1 \cos \phi_2} = 0. \quad (6)$$

$$\therefore \phi_2 = \phi_1, \text{ or } \phi_2 = \pi - \phi_1. \quad (7)$$

That is, the eccentric angles of the ends of two conjugate diameters of a hyperbola are either equal or supplementary. Therefore the corresponding diameters OQ_1, OQ_2 of the auxiliary circles are equally inclined to the transverse axes of the two conjugate hyperbolas.

Since $\tan \phi_2 = \pm \tan \phi_1$ and $\sec \phi_2 = \pm \sec \phi_1$,

the extremities of any two conjugate diameters of a hyperbola may be expressed in the form

$$\left. \begin{aligned} &P_1(a \sec \phi_1, b \tan \phi_1) \text{ and } P_2(\pm a \tan \phi_1, \pm b \sec \phi_1), \\ \text{or} &P_1(x_1, y_1) \text{ and } P_2\left(\pm \frac{a}{b}y_1, \pm \frac{b}{a}x_1\right). \end{aligned} \right\} \quad (8)$$

120. *The sum of the squares of two conjugate semi-diameters of an ellipse is constant.*

Let the extremities of any two conjugate diameters be [§ 119, (3)]

$$P_1(a \cos \phi, b \sin \phi) \text{ and } P_2(\mp a \sin \phi, \pm b \cos \phi).$$

Let $OP_1 = a', OP_2 = b', O$ being the centre.

$$\text{Then} \quad a'^2 = a^2 \cos^2 \phi + b^2 \sin^2 \phi, \quad [(4), \text{§ } 7]$$

$$b'^2 = a^2 \sin^2 \phi + b^2 \cos^2 \phi.$$

$$\therefore a'^2 + b'^2 = a^2 + b^2.$$

121. *The area of the parallelogram formed by tangents at the ends of conjugate diameters of an ellipse is constant.*

Let $P_1(a \cos \phi, b \sin \phi)$ and $P_2(\mp a \sin \phi, \pm b \cos \phi)$

be the extremities of any two conjugate diameters, and let $ABCD$ be the parallelogram formed by tangents at the ends of these diameters.

Draw P_1N perpendicular to OP_2 ; then

$$\text{Area } ABCD = 4 OP_2 \cdot P_1N = 4 b' \cdot P_1N.$$

Since OP_2 is parallel to the tangent at P_1 [§ 118, Cor. III], the equation of OP_2 may be written [(5), § 113]

$$\frac{x}{a} \cos \phi + \frac{y}{b} \sin \phi = 0.$$

$$\therefore P_1N = \frac{\cos^2 \phi + \sin^2 \phi}{\sqrt{\frac{\cos^2 \phi}{a^2} + \frac{\sin^2 \phi}{b^2}}} = \frac{ab}{\sqrt{b^2 \cos^2 \phi + a^2 \sin^2 \phi}} = \frac{ab}{b'}$$

$$\therefore \text{Area } ABCD = 4ab.$$

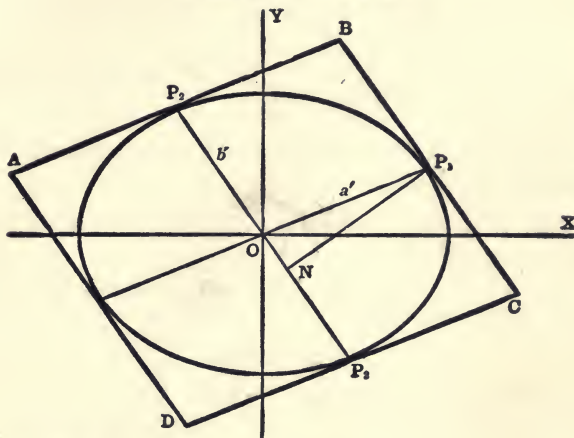

COR. If angle $P_1OP_2 = \omega$, then

$$\sin \omega = \frac{P_1N}{a'} = \frac{ab}{a'b'}$$

EXAMPLES

1. The difference of the squares of two conjugate semi-diameters of a hyperbola is constant.

2. The area of the parallelogram formed by tangents to two conjugate hyperbolas at the ends of two conjugate diameters is equal to $4ab$.

3. If ω denotes the angle between two conjugate diameters of a hyperbola, then $\sin \omega = \frac{ab}{a'b'}$.

4. Show that the acute angle between two conjugate diameters of an ellipse is least when the diameters are equal.

5. Show that the eccentric angles of the extremities of the equi-conjugate diameters of an ellipse are 45° and 135° .

6. Conjugate diameters of a rectangular hyperbola are equal, and equally inclined to the asymptotes.

7. Tangents to two conjugate hyperbolas at the extremities of two conjugate diameters meet on the asymptotes. (See Fig. § 117, II.)

8. The area of the triangle formed by two conjugate semi-diameters and the chord joining their ends is constant.

9. Prove that for all values of m the line

$$y = mx \pm \sqrt{\frac{1}{2}(a^2m^2 + b^2)}$$

passes through the extremities of two conjugate diameters of an ellipse. What is the corresponding equation for the hyperbola?

10. The product of the focal radii of a point P is equal to the square of the semi-diameter parallel to the tangent at P .

122. To find the equation of a hyperbola when referred to its asymptotes as axes of coordinates.

The equation of the asymptotes, referred to themselves as axes of coordinates, is $xy = 0$.

Therefore the equations of any two conjugate hyperbolas referred to them is of the form (§ 115)

$$xy = \pm K. \quad (9)$$

Hence the equation $xy = K$, where K is any constant, always represents a hyperbola referred to its asymptotes as axes of coordinates; so that, if the axes of coordinates are at right angles, the hyperbola $xy = K$ is rectangular.

123. To find the polar equation of a central conic, the pole being at the centre.

The formulæ for changing from rectangular to polar coordinates are (§ 6)

$$x = \rho \cos \theta, \quad y = \rho \sin \theta.$$

These values substituted in

$$\frac{x^2}{a^2} \pm \frac{y^2}{b^2} = 1$$

give

$$\rho^2 \left(\frac{\cos^2 \theta}{a^2} + \frac{\sin^2 \theta}{\pm b^2} \right) = 1,$$

or

$$\rho^2 = \frac{\pm a^2 b^2}{a^2 \sin^2 \theta \pm b^2 \cos^2 \theta} = \frac{\pm a^2 b^2}{a^2 - (a^2 \mp b^2) \cos^2 \theta}.$$

$$\therefore \rho^2 = \frac{\pm b^2}{1 - e^2 \cos^2 \theta},$$

which is the required equation.

EXAMPLES ON CHAPTER X

1. Show that the sum of the squares of the reciprocals of two perpendicular diameters of an ellipse is constant. (See § 123.)

2. If an equilateral triangle is inscribed in an ellipse, the sum of the squares of the reciprocals of the diameters parallel to the sides is constant.

3. Find the inclination to the major axis of the diameter of an ellipse the square of whose length is (1) the arithmetical mean, (2) the geometrical mean, and (3) the harmonical mean between the squares on the major and minor axes. (§ 123.) Ans. to (3), 45° .

4. The locus of the poles of a series of parallel chords is the diameter which bisects the chords. Hence the line joining the intersection of two tangents to the centre bisects the chord of contact.

✓ 5. Find the equations of two conjugate diameters of the hyperbola $b^2x^2 - a^2y^2 = a^2b^2$, one of which bisects the chord through $(0, b)$ and $(ae, 0)$.

6. In the hyperbola $4x^2 - 5y^2 = 20$ find the equations of two conjugate diameters, one of which bisects the chord $2x + 3y = 6$.

7. If straight lines drawn through any point of an ellipse to the ends of any diameter POP' meet the conjugate diameter P_1OP_1' in Q and R , show that $OQ \cdot OR = OP_1^2$.

8. Show that the locus of the intersection of the perpendiculars from the foci upon a pair of conjugate diameters of an ellipse is a similar concentric ellipse.

9. Two conjugate diameters of an ellipse are drawn, and their four extremities are joined to any point on a given circle whose centre is at the centre of the ellipse. Show that the sum of the squares of these four lines is constant.

10. P_1 is a point on a branch of a hyperbola, P_2 is a point on a branch of its conjugate, OP_1 and OP_2 being conjugate semi-diameters. If F_1 and F_2 are the interior foci of these two branches, respectively, show that

$$F_2P_2 \sim F_1P_1 = a \sim b.$$

11. Find the equation of the chord passing through the extremities of two conjugate diameters.

12. The lengths of the chords joining the extremities of two conjugate diameters of an ellipse are

$$\sqrt{a^2 + b^2 \pm a^2e^2 \sin 2\phi}.$$

For what value of ϕ are these chords, one a maximum and the other a minimum?

Show that the corresponding result for the hyperbola is

$$ae(\sec \phi \pm \tan \phi).$$

13. Find the equations and the coordinates of the points of contact of tangents to $b^2x^2 \pm a^2y^2 = a^2b^2$ which make equal intercepts on the axes.

14. If the normal at the end of the latus rectum of an ellipse passes through the extremity of the minor axis, show that the eccentricity is given by the equation $e^4 + e^2 = 1$. Find the corresponding equation for the hyperbola and interpret the result.

15. If any ordinate MP of a central conic is produced to meet the tangent at the end of the latus rectum through the focus F in Q , show that $FP = MQ$.

16. Find the product of the segments into which a focal chord of a central conic is divided by the focus.

17. Two tangents can be drawn to a central conic from any point, which will be real, coincident, or imaginary according as the point is outside, on, or inside the conic. Thus determine which is the *inside* of a hyperbola.

18. The polar of a point P with respect to an ellipse cuts the minor axis in A ; and the perpendicular from P to its polar cuts the polar in B and the minor axis in C . Show that the circle through A , B , and C will pass through the foci.

[Prove $AO \cdot OC = F'O \cdot OF$, where O is the centre.]

19. Prove that the circle on any focal radius as diameter touches the auxiliary circle.

20. Prove that the line $lx + my + n = 0$ is normal to

$$\frac{x^2}{a^2} + \frac{y^2}{b^2} = 1, \text{ if } \frac{a^2}{l^2} + \frac{b^2}{m^2} = \frac{(a^2 - b^2)^2}{n^2}.$$

[Compare $lx + my + n = 0$ with $\frac{ax}{\cos \phi} - \frac{by}{\sin \phi} = a^2 - b^2$. (See § 114.)]

21. Prove that a circle can be drawn through the foci of a hyperbola and the points in which any tangent meets the tangents at the vertices.

22. The perpendicular from the focus of an ellipse upon any tangent and the line joining the centre to the point of contact meet on the corresponding directrix.

23. If Q is the point on the auxiliary circle corresponding to the point P on the ellipse, the normals at P and Q will meet on the circle

$$x^2 + y^2 = (a + b)^2.$$

24. Prove that the focal radius of any point on a central conic and the perpendicular from the centre on the tangent at that point meet on a circle whose centre is the focus and whose radius is the semi-major axis.

25. Show that the minor axis is a mean proportional between the major axis and the latus rectum.

26. Any tangent to an ellipse meets the director circle in P and Q . Prove that OP and OQ are conjugate diameters of the ellipse.

27. Show that the line $lx + my = n$ will touch

$$\frac{x^2}{a^2} \pm \frac{y^2}{b^2} = 1 \text{ if } a^2l^2 \pm b^2m^2 = n^2.$$

The line $x \cos \alpha + y \sin \alpha = p$ will touch the same curves if

$$a^2 \cos^2 \alpha \pm b^2 \sin^2 \alpha = p^2.$$

28. Show that the equation of the locus of the foot of the perpendicular from the centre of a conic on a tangent is $\rho^2 = a^2 \cos^2 \theta \pm b^2 \sin^2 \theta$. [Use Ex. 27.]

29. If a polar with respect to a central conic touches the circle $x^2 + y^2 = b^2$, what is the locus of the pole?

30. Show that the polar of any point on either of the curves

$$\frac{x^2}{a^2} \pm \frac{y^2}{b^2} = 1$$

with respect to the other touches the first curve.

31. The polar of any point P on either of the curves

$$\frac{x^2}{a^2} - \frac{y^2}{b^2} = \pm 1$$

with respect to the other touches the first curve at the opposite extremity of the diameter through P .

32. The polars of any point with respect to the two conics

$$\frac{x^2}{a^2} - \frac{y^2}{b^2} = \pm 1$$

are parallel and equidistant from the centre.

33. The product of the focal radii of any point on a rectangular hyperbola is equal to the square of the distance from the centre to that point.

34. The distance of any point Q from the centre of a rectangular hyperbola varies inversely as the perpendicular from the centre upon the polar of Q .

35. If the normal at any point P of a rectangular hyperbola meets the axes in N and N' , and O is the centre, then $PN = PN' = OP$.

36. A line parallel to the y -axis meets two conjugate hyperbolas and one of their asymptotes in P , Q , R . Show that the normals at P , Q , R meet on the x -axis.

37. If Q is the point on the auxiliary circle corresponding to the point P on the ellipse, show that the perpendicular distances of the foci F, F' from the tangent at Q are equal to FP and $F'P$ respectively.

38. If P is a point on the director circle of an ellipse, and O the centre, the product of the distances of O and P from the polar of P with respect to the ellipse is constant.

39. Show that the ellipse is concave towards both axes, while the hyperbola is concave only towards its transverse axis.

40. Chords are drawn through the end of an axis of an ellipse. Find the locus of their middle points.

41. If the eccentric angles of two points P, Q on an ellipse are ϕ_1, ϕ_2 , prove that the area of the parallelogram formed by tangents at the ends of diameters through P and Q is

$$4 ab \csc(\phi_1 - \phi_2);$$

and hence show that this area is least when P and Q are the ends of conjugate diameters.

42. The sides of a parallelogram circumscribing an ellipse are parallel to conjugate diameters; prove that the product of the perpendiculars from two opposite vertices on any tangent is equal to the product of those from the other two vertices.

43. The radius of a circle which touches a hyperbola and its asymptotes is equal to that part of the latus rectum intercepted between the curve and the asymptotes.

44. Show that the area of a triangle inscribed in an ellipse is

$$\frac{1}{2} ab [\sin(\alpha - \beta) + \sin(\beta - \gamma) + \sin(\gamma - \alpha)],$$

where α, β, γ are the eccentric angles of the vertices.

Prove also that its area is to the area of the triangle formed by the corresponding points on the auxiliary circle as $b : a$; and hence its area is a maximum when the latter is equilateral; *i.e.* when

$$\alpha \sim \beta = \beta \sim \gamma = \gamma \sim \alpha = \frac{2}{3} \pi.$$

45. If a tangent drawn at any point P of the inner of two similar coaxial conics meets the outer in the points T and T' , then any chord of the inner through P is half the algebraic sum of the parallel chords of the outer through T and T' .

46. DEF. The two chords of a central conic which join any point on the curve to the extremities of any diameter are called *Supplemental Chords*.

Show that two supplemental chords are parallel to a pair of conjugate diameters.

CHAPTER XI

GENERAL EQUATION OF THE SECOND DEGREE

124. It has been shown in § 87 that the most general equation of a conic is the complete equation of the second degree. We shall now show that the general equation,

$$ax^2 + 2hxy + by^2 + 2gx + 2fy + c = 0, \quad (1)$$

can always be changed into one of the standard forms [§§ 88–90], and will thus prove that its locus is always a conic, either in one of the common forms or in one of the limiting cases. In order to do this we will first remove the terms of the first degree.

The equation referred to parallel axes through the point (x', y') will be found by substituting $x + x'$ for x and $y + y'$ for y [§ 53], and will therefore be, after collecting terms,

$$ax^2 + 2hxy + by^2 + 2x(ax' + hy' + g) + 2y(hx' + by' + f) + ax'^2 + 2hx'y' + by'^2 + 2gx' + 2fy' + c = 0. \quad (2)$$

If, as is generally possible, x' and y' be so chosen that

$$ax' + hy' + g = 0, \quad (3)$$

and
$$hx' + by' + f = 0, \quad (4)$$

the coefficients of x and y in (2) will both vanish, and the equation referred to (x', y') as origin will then be

$$ax^2 + 2hxy + by^2 + c' = 0, \quad (5)$$

where
$$c' \equiv ax'^2 + 2hx'y' + by'^2 + 2gx' + 2fy' + c. \quad (6)$$

The locus represented by (5) is symmetrical with respect to the origin [§ 28, (9)]; *i.e.* the origin is now at the centre.

Hence the coordinates of the centre of the conic represented by (1) are the values of x' and y' which satisfy equations (3) and (4),

i.e.
$$x' = \frac{fh - bg}{ab - h^2}, \quad y' = \frac{gh - af}{ab - h^2}. \quad (7)$$

Hence, if $h^2 - ab \neq 0$, the coordinates of the centre are both finite, and this transformation is possible.

Multiply equations (3) and (4) by x' and y' , respectively, and subtract the sum from the right member of (6); we thus get

$$c' = gx' + fy' + c. \quad (8)$$

$$\therefore c' = g\left(\frac{fh - bg}{ab - h^2}\right) + f\left(\frac{gh - af}{ab - h^2}\right) + c \quad \text{from (7)}$$

$$= \frac{abc + 2fgh - af^2 - bg^2 - ch^2}{ab - h^2} = \frac{\Delta}{ab - h^2}, \quad (9)$$

where $\Delta \equiv abc + 2fgh - af^2 - bg^2 - ch^2. \quad (10)$

If $\Delta = 0$, then $c' = 0$, and equation (5) may be written

$$ax + hy = \mp y\sqrt{h^2 - ab}. \quad (11)$$

Hence the locus is two straight lines, which will be real, coincident, or imaginary according as $h^2 - ab >, =, \text{ or } < 0$.

If $\Delta = 0$, and also $ab - h^2 = 0$, then c' is not necessarily zero.

The first three terms of equation (5) are then a perfect square. The equation may therefore be written

$$\sqrt{ax} + \sqrt{by} \pm \sqrt{-c'} = 0, \quad (12)$$

and represents two parallel lines, which coincide when $c' = 0$.

The function of the coefficients denoted above by the symbol Δ is called the **Discriminant** of the General Equation.

Hence an equation of the second degree will represent two straight lines if its discriminant vanishes.

125. When $h^2 - ab \neq 0$.

In order to reduce the equation [(5), § 124]

$$ax^2 + 2hxy + by^2 + c' = 0, \quad (1)$$

to any one of the standard forms (§§ 89, 90) we must remove the term $2hxy$. For this purpose we turn the axes through a certain angle θ , keeping the origin fixed.

To turn the axes through an angle θ we substitute for x and y , respectively [§ 54, (1)],

$$x \cos \theta - y \sin \theta \quad \text{and} \quad x \sin \theta + y \cos \theta. \quad (2)$$

Substituting these values in (1), expanding and collecting terms, we have

$$\begin{aligned}
 & (a \cos^2 \theta + 2h \sin \theta \cos \theta + b \sin^2 \theta)x^2 \\
 & + 2[(b - a) \sin \theta \cos \theta + h(\cos^2 \theta - \sin^2 \theta)]xy \\
 & + (a \sin^2 \theta - 2h \sin \theta \cos \theta + b \cos^2 \theta)y^2 + c' = 0. \quad (3)
 \end{aligned}$$

The coefficient of xy in equation (3) will vanish if θ be so chosen that

$$2(b - a) \sin \theta \cos \theta + 2h(\cos^2 \theta - \sin^2 \theta) = 0. \quad (4)$$

i.e. if $(a - b) \sin 2\theta = 2h \cos 2\theta. \quad (5)$

$$\therefore \tan 2\theta = \frac{2h}{a - b}. \quad (6)$$

Whence $\sin 2\theta = \pm \frac{2h}{\sqrt{(a - b)^2 + 4h^2}}, \quad (7)$

and $\cos 2\theta = \pm \frac{a - b}{\sqrt{(a - b)^2 + 4h^2}}. \quad (8)$

Any value of θ obtained from (6) will reduce (3) to the form

$$a'x^2 + b'y^2 + c' = 0, \text{ or } \frac{x^2}{-\frac{c'}{a'}} + \frac{y^2}{-\frac{c'}{b'}} = 1, \quad (9)$$

where $a' \equiv a \cos^2 \theta + 2h \sin \theta \cos \theta + b \sin^2 \theta, \quad (10)$

and $b' \equiv a \sin^2 \theta - 2h \sin \theta \cos \theta + b \cos^2 \theta. \quad (11)$

Equation (9) is therefore the required result.

The values of a' and b' may be expressed in terms of a , b , and h as follows:

From (10) and (11), by addition and subtraction, we obtain

$$a' + b' = a + b, \quad (12)$$

and $a' - b' = (a - b) \cos 2\theta + 2h \sin 2\theta. \quad (13)$

Substituting (7) and (8) in (13) gives

$$a' - b' = \pm \sqrt{(a - b)^2 + 4h^2} = \frac{2h}{\sin 2\theta}. \quad (14)$$

Whence, from (12) and (14),

$$a' = \frac{1}{2} \{ a + b \pm \sqrt{(a - b)^2 + 4h^2} \}, \quad (15)$$

and $b' = \frac{1}{2} \{ a + b \mp \sqrt{(a - b)^2 + 4h^2} \}. \quad (16)$

The ambiguity in the values of a' and b' given by (15) and (16) may be removed by (14). From the many values of θ which satisfy (6) we will agree always to choose that one which lies between 0° and 180° . Then θ will always be an *acute* angle, and $\sin 2\theta$ will always be *positive*. Therefore it follows from (14) that $a' - b'$ will always have the *same sign* as h .

It is also worthy of notice that the values of a' and b' given by (15) and (16) are the two roots of the equation

$$x^2 - (a + b)x - (h^2 - ab) = 0. \quad (17)$$

Hence a' and b' will have the *same sign* or *opposite* signs, *i.e.* the conic will be an ellipse or a hyperbola according as

$$h^2 - ab <, \text{ or } > 0.$$

If $a + b = 0$, then $a' = -b'$ and the conic is a rectangular hyperbola.

Ex. Transform the equation

$$8x^2 + 4xy + 5y^2 + 8x - 16y - 16 = 0$$

to the standard form, and construct the conic.

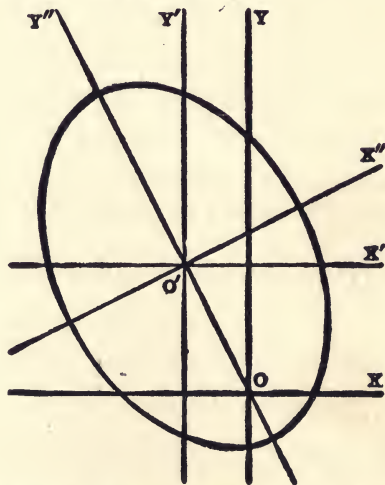

The equations for finding the centre are $4x + y + 2 = 0$ and $2x + 5y = 8$.

$$\therefore x' = -1, y' = 2.$$

Then

$$c' \equiv gx' + fy' + c = -36.$$

Therefore the equation referred to parallel axes $O'X'$, $O'Y'$ through the

centre is

$$8x^2 + 4xy + 5y^2 = 36.$$

Also $a' = \frac{1}{2} \{a + b \pm \sqrt{(a-b)^2 + 4h^2}\} = \frac{1}{2} (13 \pm 5) = 9 \text{ or } 4,$

$$b' = \frac{1}{2} \{a + b \mp \sqrt{(a-b)^2 + 4h^2}\} = \frac{1}{2} (13 \mp 5) = 4 \text{ or } 9.$$

Since h is positive, we take $a' = 9$ and $b' = 4$.

Hence the equation of the curve referred to its own axes $O'X'$, $O'Y'$ as axes of coordinates is

$$\frac{x^2}{4} + \frac{y^2}{9} = 1.$$

Also $\tan 2\theta = \frac{2h}{a-b} = \frac{4}{3}.$

Therefore the line $O'X''$ must be drawn so that $\angle X'O'X'' = \frac{1}{2} \tan^{-1} \frac{4}{3},$

126. When $h^2 - ab = 0$.

In this case the coordinates of the centre [(7), § 124] are both infinite, and therefore the first degree terms cannot be removed by changing to a new system of axes parallel to the old.

Since the second degree terms now form a perfect square, the general equation may be written

$$(\beta y + \alpha x)^2 + 2gx + 2fy + c = 0, \quad (1)$$

where $\alpha \equiv \sqrt{a}$, $\beta \equiv \sqrt{b}$, α has the same sign as h , and β is always positive.

$$\therefore h = \alpha\beta. \quad (2)$$

First Method. From equation (6), § 125, we have

$$\tan 2\theta = \frac{2h}{a-b} = \frac{2\alpha\beta}{\alpha^2 - \beta^2} = \frac{2 \tan \theta}{1 - \tan^2 \theta}. \quad (3)$$

$$\therefore \tan \theta = \frac{\beta}{\alpha}, \text{ or } -\frac{\alpha}{\beta}. \quad (4)$$

If we turn the axes through an angle given by either of these values of $\tan \theta$, the coefficient of xy in the new equation will vanish.

If we take $\theta = \tan^{-1} \left(-\frac{\alpha}{\beta} \right)$, the equation of the new x -axis will be

$$\alpha x + \beta y = 0. \quad (5)$$

We will use this value, and will agree always to take the positive direction of the new x -axis so that θ shall be numerically less than 90° . Then θ will be positive or negative according as h (or α) is

negative or positive, and we have from (4)

$$\sin \theta = \frac{-\alpha}{+\sqrt{\alpha^2 + \beta^2}}, \quad \cos \theta = \frac{\beta}{+\sqrt{\alpha^2 + \beta^2}}.$$

Hence, to turn the axes through an angle θ thus chosen, we must substitute for x and y , respectively [§ 54, (1)],

$$\frac{\beta x + \alpha y}{\sqrt{\alpha^2 + \beta^2}} \text{ and } \frac{-\alpha x + \beta y}{\sqrt{\alpha^2 + \beta^2}}. \quad (6)$$

Substituting the expressions (6) in (1) gives

$$(\alpha^2 + \beta^2)y^2 + 2\frac{\beta g - \alpha f}{\sqrt{\alpha^2 + \beta^2}}x + 2\frac{\alpha g + \beta f}{\sqrt{\alpha^2 + \beta^2}}y + c = 0. \quad (7)$$

Completing the square in the terms containing y , equation (7) may be reduced to the form

$$(y - K)^2 = 2\frac{\alpha f - \beta g}{\sqrt{(\alpha^2 + \beta^2)^3}}(x - H), \quad (8)$$

where

$$H \equiv \frac{c(\alpha^2 + \beta^2)^2 - (\alpha g + \beta f)^2}{2(\alpha f - \beta g)\sqrt{(\alpha^2 + \beta^2)^3}},$$

and

$$K \equiv -\frac{\alpha g + \beta f}{\sqrt{(\alpha^2 + \beta^2)^3}}.$$

If now the origin be moved to the point (H, K) , equation (8) will take the standard form

$$y^2 = 2\frac{\alpha f - \beta g}{\sqrt{(\alpha^2 + \beta^2)^3}}x. \quad (9)$$

Therefore equation (1) represents a parabola whose axis is parallel to the line (5), and whose latus rectum is

$$\frac{2(\alpha f - \beta g)}{\sqrt{(\alpha^2 + \beta^2)^3}}.$$

Second Method. Equation (1) may be written

$$(ax + \beta y + \lambda)^2 = 2(\alpha\lambda - g)x + 2(\beta\lambda - f)y + \lambda^2 - c, \quad (10)$$

where λ is any constant, for which a particular value will now be determined.

We observe that the line whose equation is

$$ax + \beta y + \lambda = 0 \quad (11)$$

is parallel to the axis of the parabola [see (5) above] for all values of λ . Hence we will choose λ so that the straight line

$$2(\alpha\lambda - g)x + 2(\beta\lambda - f)y + \lambda^2 - c = 0 \quad (12)$$

shall be perpendicular to the line (11).

The lines (11) and (12) will be at right angles (§ 45) if

$$\alpha(\alpha\lambda - g) + \beta(\beta\lambda - f) = 0,$$

i.e. if
$$\lambda = \frac{\alpha g + \beta f}{\alpha^2 + \beta^2} \equiv \lambda_1. \quad (13)$$

With this value, λ_1 , equation (10) may be written

$$(\alpha x + \beta y + \lambda_1)^2 = 2 \frac{\alpha f - \beta g}{\alpha^2 + \beta^2} (\beta x - \alpha y + K), \quad (14)$$

where

$$K \equiv \frac{\alpha^2 + \beta^2}{\alpha f - \beta g} \left(\frac{\lambda_1^2 - c}{2} \right). \quad (15)$$

Changing the linear expressions in (14) to the distance form gives

$$\left(\frac{\alpha x + \beta y + \lambda_1}{\sqrt{\alpha^2 + \beta^2}} \right)^2 = 2 \frac{\alpha f - \beta g}{\sqrt{(\alpha^2 + \beta^2)^3}} \left(\frac{\beta x - \alpha y + K}{\sqrt{\alpha^2 + \beta^2}} \right). \quad (16)$$

If now we take the lines

$$\alpha x + \beta y + \lambda_1 = 0 \quad (17)$$

and

$$\beta x - \alpha y + K = 0 \quad (18)$$

for new axes of x and y , respectively, the new equation will be

$$y^2 = 2 \frac{\alpha f - \beta g}{\sqrt{(\alpha^2 + \beta^2)^3}} x. \quad (19)$$

Hence (17) represents the axis of the parabola, and (18) the tangent at the vertex. The curve will lie on the *positive* or *negative side* of the line (18) according as $(\alpha f - \beta g)$ is *positive* or *negative*.

If, $\alpha\lambda_1 - g = \beta\lambda_1 - f = 0$, the line (12) cannot be determined. But in this case equation (10) reduces to

$$(\alpha x + \beta y + \lambda_1)^2 = \lambda_1^2 - c, \quad (20)$$

that is, the conic then consists of two parallel lines.

Ex. Find the standard form of the equation

$$(4y - 3x)^2 - 20x + 110y - 75 = 0. \quad (1)$$

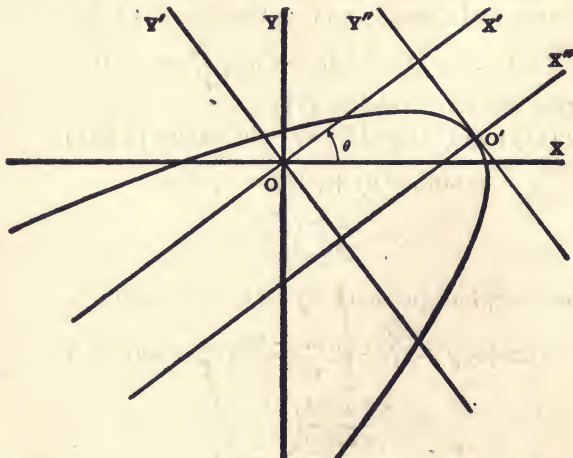

First Method. Take $4y - 3x = 0$ as the new x -axis; i.e. turn the axes through an angle θ , such that $\tan \theta = \frac{3}{4}$, and therefore $\sin \theta = \frac{3}{5}$, $\cos \theta = \frac{4}{5}$.

Then the formulæ of transformation are

$$x = x' \cos \theta - y' \sin \theta = \frac{4x' - 3y'}{5},$$

and

$$y = x' \sin \theta + y' \cos \theta = \frac{3x' + 4y'}{5}.$$

Substituting these values in equation (1), it becomes

$$y'^2 + 2x' + 4y' - 3 = 0,$$

or

$$(y' + 2)^2 = -2(x' - \frac{7}{2}), \quad (2)$$

which is the equation of the curve referred to the new axes $O'X'$, $O'Y'$.

Moving the origin to the point $O'(\frac{7}{2}, -2)$, with respect to the new axes, we obtain from (2) the required equation

$$y''^2 = -2x''. \quad (3)$$

Hence the curve is on the negative side of the y -axis $O'Y''$.

Second Method. The given equation (1) may be written

$$(4y - 3x + \lambda)^2 = (20 - 6\lambda)x + (8\lambda - 110)y + \lambda^2 + 75. \quad (4)$$

We will now determine λ so that the two lines

$$4y - 3x + \lambda = 0 \quad (5)$$

and

$$(20 - 6\lambda)x + (8\lambda - 110)y + \lambda^2 + 75 = 0 \quad (6)$$

shall be at right angles.

The required value of λ is given by the equation (§ 45)

$$-3(20 - 6\lambda) + 4(8\lambda - 110) = 0.$$

$$\therefore \lambda = 10.$$

With this value of λ equation (4) becomes

$$(4y - 3x + 10)^2 = -10(4x + 3y - 17\frac{1}{2}),$$

$$\text{or} \quad \left(\frac{4y - 3x + 10}{5}\right)^2 = -2\left(\frac{4x + 3y - 17\frac{1}{2}}{5}\right). \quad (7)$$

Draw the lines

$$4y - 3x + 10 = 0, \quad O'X'', \quad (8)$$

$$\text{and} \quad 4x + 3y - 17\frac{1}{2} = 0, \quad O'Y''. \quad (9)$$

These lines are at right angles. If we take (8) as the new x -axis and (9) as the new y -axis, the equation of the curve will be

$$y^2 = -2x. \quad (10)$$

Therefore the locus is a parabola whose latus rectum is 2, and lies on the *negative side* of the line (9).

EXAMPLES

Construct the following conics by transforming the equations to their standard forms:

1. $(4y - 3x)^2 + 4(4x + 3y) = 0.$

3. $3x^2 + 2xy + 3y^2 = 8.$

2. $(3x - 4y - 12)^2 = 15(4x + 3y).$

4. $x^2 - 6xy + y^2 = 16.$

5. $4x^2 - 24xy + 11y^2 - 16x - 2y - 89 = 0.$

7. $2x^2 + 4xy + 5y^2 = 36.$

6. $5x^2 - 4xy + 8y^2 - 22x + 16y - 10 = 0.$

8. $8x^2 - 5xy - 4y^2 = 34.$

9. $9x^2 - 12xy + 4y^2 = 10(2x + 3y + 5).$

10. $3x^2 - 2xy + 2y^2 - 16x - 8y + 8 = 0.$

15. $2x^2 + xy + 3y^2 = 23.$

11. $6x^2 + 24xy - y^2 + 50y - 55 = 0.$

16. $xy + 3x - 5y + 5 = 0.$

12. $x^2 - 2xy + y^2 - 5x - y - 2 = 0.$

17. $x^2 + 4y^2 + 4x = 0.$

13. $x^2 - 6xy + 9y^2 - 2x + 6y + 1 = 0.$

18. $4x^2 - 9y^2 + 24x = 0.$

14. $4x^2 + 4xy + y^2 + 4x - 3y + 4 = 0.$

19. $24xy + 7y^2 - 6(8x - 10y - 9) = 0.$

20. $25x^2 - 20xy + 4y^2 + 5x - 2y - 6 = 0.$

21. $2x^2 + 7xy - 4y^2 + 4x + 7y - 18\frac{1}{2} = 0.$

25. $x^2 - 2xy - y^2 = 20.$

22. $2x^2 + xy - 6y^2 - 5x + 11y - 3 = 0.$

26. $(5y + 12x)^2 = 102x.$

23. $x^2 + 2xy + y^2 - 12x + 2y - 3 = 0.$

24. $x^2 - xy - 2y^2 - x - 4y - 2 = 0.$

27. $x^2 - 4x - 3y = 5.$

EXAMPLES ON LOCI

1. Show that the locus of a point, the sum of the squares of whose distances from n fixed points is constant, is a circle.
2. Find the locus of the centre of a variable circle which touches a fixed circle and a fixed straight line.
3. Find the locus of the centre of a circle which touches two fixed circles. Four cases should be considered. What does the locus become when the fixed circles are equal?
4. Find the locus of the middle points of all chords of a given circle which pass through a fixed point. [Take the fixed point as pole.]
5. A straight rod moves so that its ends constantly touch two fixed perpendicular rods. Find the locus of any point P on the moving rod.
6. On a level plain the crack of a rifle and the thud of the ball striking the target are heard at the same instant. Find the locus of the hearer. [S. L. Loney's Coordinate Geometry, p. 283.]
7. In a given circle let AOB be a fixed diameter, OC any radius, CD the perpendicular from C on AB ; let P and Q be two points on the line through O and C such that $QO = OP = DC$. Find the locus of P and Q as OC turns about O .
8. A and B are two fixed points, and P moves so that $PA = n \cdot PB$. Find the locus of P .
9. AOB and COD are two straight lines which bisect one another at right angles. Find the locus of a point P such that $PA \cdot PB = PC \cdot PD$.
10. If ABC is an equilateral triangle, find the locus of a point P such that $PA^2 = PB^2 + PC^2$.
11. AB is a fixed diameter of a given circle and AC is any chord; P and Q are two points on the line AC such that $QC = CP = CB$. Find the locus of P and Q as AC turns about A .
12. Any straight line is drawn from a fixed point O meeting a fixed straight line in P , and a point Q is taken in this line such that $OP \cdot OQ$ is constant. Find the locus of Q .
13. Any straight line is drawn from a fixed point O meeting a fixed circle in P , and on this line a point Q is taken such that $OP \cdot OQ$ is constant. Show that the locus of Q is a circle. [See suggestion under Ex. 4.]
14. Find the locus of a point such that the sum of the squares of its distances from the sides of an equilateral triangle is constant.
15. The square of the distance of a point P from the base of an isosceles triangle is equal to the product of its distances from the other two sides. Find the locus of P .

MISCELLANEOUS PROBLEMS ON LOCI

1. Show that the curve on the concave side of the new moon is an ellipse.
2. A circular cylinder rolls along on a plane surface. Find the locus of the point of contact between the plane surface and an oblique plane section of the cylinder.
3. What kind of a curve must be used in making a pattern for cutting elbows of stovepipe from sheet iron?
4. If the hub of a cart-wheel is not perpendicular to the plane of the wheel, what kind of a curve is the track of the wheel on a level road? Is this problem the same as No. 2? If not, why?
5. If a wheel is rotating on a fixed axle with a uniform angular velocity, while a fly is crawling outward along a spoke of the wheel at a constant rate, what is the equation of the locus of the fly in the plane?
6. If a spiral spring rolls on a plane surface, what kind of a track does it make?
7. What kind of a curve is the shadow of a spiral spring, if the rays of light are all perpendicular to the plane of the shadow, and the axis of the spring parallel to the plane?
8. The curve described by a piece of paper sticking to the rim of a cart-wheel as the wheel rolls along in a straight line on a level road is called a **Cycloid**.

Take the origin at the point where the piece of paper was originally on the ground, and use the wheel's track as the x -axis; let θ represent the angle through which the wheel has turned, and a the radius of the wheel. Then show that

$$x = a(\theta - \sin \theta), \text{ and } y = a(1 - \cos \theta).$$

Eliminate θ and show that the equation of the cycloid is

$$x = a \operatorname{vers}^{-1} \frac{y}{a} - \sqrt{2ay - y^2}.$$

9. In 2 minutes after leaving a station a railroad train attains a speed of 40 miles an hour, which it maintains for 3 minutes; then it strikes a grade, and in 1 minute its speed is reduced to 30 miles, which it maintains for 3 minutes; in 1 minute more it slows down and stops at the next station. Draw a curve whose ordinate shall represent approximately the speed of the train. What is the approximate distance between the stations?

10. In a steel bar the stretch varies as the strain until the elastic limit is reached. From this on the stretch varies at a greater and greater rate with regard to strain until the bar snaps. Draw a curve which will illustrate this law.

11. The specific heat of ice is .5, of water 1. It requires 80 calories of heat to convert 1 gram of ice at 0° C. into water at 0° C., and about 500 calories to convert 1 gram of water at 100° C. into steam at 100° C. Draw a curve whose ordinate shall show the change in temperature, *per calorie*, at every stage of the process as 1 gram of ice at -40° C. is converted into steam.

12. It is a law of physics that the product of the volume and pressure of a gas is constant. Construct the graphical representation of this law. What kind of a curve is it?

13. Suppose the steam is allowed to enter a cylinder during only one-fourth of the stroke. Draw a curve whose ordinate shall represent theoretically the pressure on the piston.

14. Waves from two different centres have the same length. Find the locus of the points where crest coincides with crest and where trough meets trough. Find also the locus of the points where the crests of one wave coincide with the troughs of the other.

15. Find the locus of all points in a plane that are equally illuminated by two lights situated in the plane. What is the locus in space?

16. If a vertical tube is moved horizontally with a uniform velocity, while a ball is falling freely through the tube, what is the path described by the ball? (We here assume that the student is familiar with the law of falling bodies, viz. $s = \frac{1}{2}gt^2$.)

17. Show that the equation of the path of a projectile fired from a gun with an initial velocity of c feet per second, θ being the angle of elevation of the gun, is

$$y = x \tan \theta - \frac{gx^2}{2c^2} \sec^2 \theta,$$

the origin being at the muzzle of the gun, and the x -axis horizontal.

Find also the *horizontal range* of the projectile, and show that any two complementary angles of elevation will give the same range.

Show also that the range is a maximum when $\theta = 45^{\circ}$.

Show that the angle of elevation required to strike a given point (x', y') is given by the formula

$$\tan \theta = \frac{c^2 \pm \sqrt{c^4 - g^2x'^2 - 2c^2gy'}}{gx'}$$

18. Draw a curve which will show the relation between a man's daily wages and the number of days he must work in order to be able to meet his necessary annual expenses.

19. The manager of a gas plant finds that his customers will spend annually a fixed sum for gas. Find the curve that will show the relation between the price of gas and the quantity of gas that can be sold.

20. The annual expense of a business firm for rent, interest, taxes, insurance, depreciation of plant, etc., is practically constant. Draw a curve which will show the relation between the daily volume of business and the number of days necessary to run the business in order to meet these fixed charges.

21. The *revenue* from the sale of a commodity is the product of the price by the quantity sold. Using price as ordinate, draw a curve which shall show the relation between the price (p) and the quantity sold (q), if the revenue (R) is constant.

Such a curve may be called a *Constant Revenue Curve*. What kind of a curve is it?

22. Draw a curve showing the relation between the demand for a commodity and its market price, using price for ordinate. (*Demand Curve*.) Draw another curve showing the relation between the supply and the cost of production of this same commodity, using cost for ordinate. (*Supply Curve*.) What is indicated by the point of intersection of these two curves? Draw a third curve whose ordinate shall be the ordinate of the demand curve minus the ordinate of the supply curve. (*Monopoly Revenue Curve*.) What does the ordinate of this third curve represent? Now construct a constant revenue curve (see Ex. 21) which shall touch this last curve. What is the significance of this point of contact? (See Principles of Economics by Alfred Marshall, Vol. I, 3d Ed., p. 535.)

23. Find the equation of a curve whose ordinate shall represent the amount of a given principal at a fixed rate of compound interest, using time as abscissa.



SOLID GEOMETRY

CHAPTER XII

SYSTEMS OF COORDINATES, THE POINT, RECTANGULAR COORDINATES

127. In the rectangular system of coordinates, three mutually perpendicular planes XOY , YOZ , ZOX are chosen as planes of reference. These planes are called **Coordinate Planes**; their lines of intersection OX , OY , OZ , **Coordinate Axes**; and their point of intersection, O , the **Origin**.

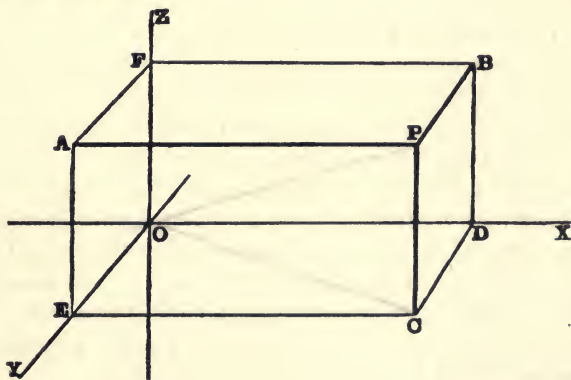

The position of a point P in space is then completely determined when its distances AP , BP , CP , from each of these planes, measured parallel to the coordinate axes, and the *direction* in which these distances are measured, are given. These three lines, or the numbers which represent them, are called the **Rectangular Coordinates** of the point P , and are always written in the order (x, y, z) .

We shall consider distances positive when measured in the directions OX , OY , or OZ ; that is, to the right, forward, or upward. Then distances measured in the opposite directions will be negative.

The coordinate planes divide all space into eight equal compartments, which may, for convenience, be called *Octants*. The octant $O-XYZ$ is called the first, but there is no established order for numbering the others.

The position of any point $P(a, b, c)$ (a , b , and c being positive numbers) may be found as follows: measure on the axes the distances $OD = a$, $OE = b$, $OF = c$, and through the points D , E , F draw planes parallel to the coordinate planes, forming a rectangular parallelepiped; the intersection of these three planes will be the required point P .

There are seven other points whose absolute distances from the coordinate planes are the same as those of P . What are their coordinates? What do these eight points form? What are the coordinates of the points A , B , C , D , E , F ?

Moreover, it is obvious that $x = a$ for all points in the plane $PBDC$ indefinitely extended; also that $x = a$ and $y = b$ for all points on the indefinite line PC . Or, in other words, $x = a$ is the equation of the plane; $x = a$, $y = b$ are the equations of the line PC ; while $x = a$, $y = b$, $z = c$ are the equations of the point P . Thus, the more the location of a point is restricted, the greater the number of equations its coordinates must satisfy. What are the equations of the other faces of this parallelepiped? the other edges?

It is easy to see that the system of rectangular coordinates in a plane is a special case of the more general system here described, in which one of the coordinates has become zero. Hence we shall find that we can reduce formulæ in solid geometry to the corresponding formulæ in plane geometry by placing z equal to zero. The student should bear this constantly in mind.

EXAMPLES

1. What are the equations of the coordinate planes? the coordinate axes?
2. What is the locus of the point (x, y, z) if $x = y$? $y = z$? $z = x$? $x = -y$? $y = -z$? $z = -x$?

3. What is the locus of the point (x, y, z) if $x = y = z$? $x = -y = z$? $x = y = -z$? $x = -y = -z$?

Let P in the figure be the point (a, b, c) .

4. Show that for every point in OP $\frac{x}{a} = \frac{y}{b} = \frac{z}{c}$.

5. Show that the equation of the plane $ABDE$ is $\frac{x}{a} + \frac{y}{b} = 1$.

6. Find the equations of the planes $OFPC$, $ODPA$, and $OEPB$.

128. To find the coordinates of a point which divides the straight line joining two given points in a given ratio $m_1 : m_2$.

Let (x_1, y_1, z_1) and (x_2, y_2, z_2) be the two given points, and (x, y, z) the required point.

The proof is precisely the same as that given for the corresponding theorem in plane geometry (§ 9). The results are

$$x = \frac{m_1x_2 + m_2x_1}{m_1 + m_2}, \quad y = \frac{m_1y_2 + m_2y_1}{m_1 + m_2}, \quad z = \frac{m_1z_2 + m_2z_1}{m_1 + m_2}. \quad (1)$$

If (x, y, z) is the middle point of the line, then

$$x = \frac{x_1 + x_2}{2}, \quad y = \frac{y_1 + y_2}{2}, \quad z = \frac{z_1 + z_2}{2}. \quad (2)$$

129. To find the distance between two points whose rectangular coordinates are given.

Let $P_1(x_1, y_1, z_1)$ and $P_2(x_2, y_2, z_2)$ be the given points.

Through the points P_1 and P_2 draw planes parallel to the coordinate planes, forming a rectangular parallelepiped, whose diagonal is P_1P_2 , and whose edges P_2Q , QR , RP_1 are parallel to the axes.

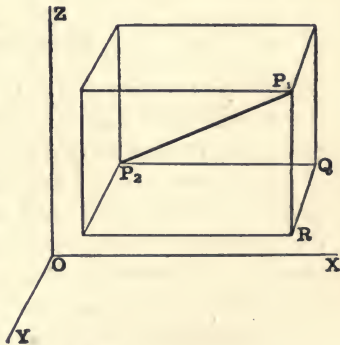

Then $P_2P_1^2 = P_2Q^2 + QR^2 + RP_1^2$.

But $P_2Q = x_1 - x_2$, $QR = y_1 - y_2$, and $RP_1 = z_1 - z_2$.

$$\therefore P_2P_1 = \sqrt{(x_1 - x_2)^2 + (y_1 - y_2)^2 + (z_1 - z_2)^2}. \quad (1)$$

If ρ represents the distance of any point (x, y, z) from the origin, then

$$\rho = \sqrt{x^2 + y^2 + z^2}. \quad (2)$$

EXAMPLES

1. Show that the coordinates of the centre of gravity of the triangle whose vertices are (x_1, y_1, z_1) , (x_2, y_2, z_2) , and (x_3, y_3, z_3) are

$$\frac{x_1 + x_2 + x_3}{3}, \frac{y_1 + y_2 + y_3}{3}, \text{ and } \frac{z_1 + z_2 + z_3}{3}.$$

2. Show that the four lines which join the vertices of a tetrahedron to the centres of gravity of the opposite faces meet in a point which divides the lines in the ratio 3 : 1. (This point is the centre of gravity of the tetrahedron.)

3. Show that the centre of gravity of any tetrahedron bisects each of the three lines joining the middle points of the opposite edges. What does this theorem become if we consider the four points as vertices of a twisted quadrilateral? What when the fourth point moves into the plane of the other three?

4. Show that the sum of the squares of the diagonals of any quadrilateral is twice the sum of the squares of the lines joining the middle points of the opposite sides. State the corresponding theorem for a tetrahedron.

5. Show that the sum of the squares of two pairs of opposite edges of a tetrahedron is equal to the sum of the squares of the third pair of opposite edges plus four times the square of the line joining the middle points of the third pair. What is the corresponding theorem for a twisted quadrilateral? For a plane quadrilateral?

ORTHOGONAL PROJECTIONS

130. The points A, B, C (§ 127) are the projections of P on the three coordinate planes; while D, E, F are its projections on the axes. The projection of any locus on a given plane is the locus of the projections of all the points of the given locus. The angle between a straight line and a plane is the angle the line makes with its projection on the plane. Hence, from plane geometry, *the projection of a limited line on any plane is equal to the line multiplied by the cosine of the angle between the line and the plane.*

The projection of a limited line on an *axis* (any other line) is that part of the axis intercepted between two planes through the ends of the line perpendicular to the axis. The projections of a line on a series of *parallel axes* are evidently all equal. The angle between two lines which do not intersect is equal to the angle between two intersecting lines parallel respectively to the two given lines.

Hence, as in plane geometry, *the projection of a limited line on any axis is equal to the line multiplied by the cosine of the angle between the line and the axis.*

Also, *the projection of a broken line (in space) on any axis is equal to the projection, on the same axis, of the straight line joining the ends of the broken line.*

For example, let ρ be the distance from the origin to the point (x, y, z) . Then, projecting on any line we get

$$\text{Proj. of } \rho = \text{Proj. of } x + \text{Proj. of } y + \text{Proj. of } z. \quad (1)$$

This equation is evidently true if ρ is the diagonal, and x, y, z are the three dimensions of any rectangular parallelepiped. We shall frequently have occasion to use this special case of the last theorem.

POLAR COORDINATES. DIRECTION COSINES

131. Let $P(x, y, z)$ be any point in space referred to rectangular axes.

The position of P will evidently be determined if we know its distance ρ from the origin and the angles α, β, γ , which OP makes with the axes. The four quantities $(\rho, \alpha, \beta, \gamma)$ are the **Polar Coordinates** of P . The distance ρ is called the *Radius Vector* of the point P , and α, β, γ are called the *Direction Angles* of the line OP .

Since $x, y,$ and z are the projections of ρ on the three axes, we have

$$x = \rho \cos \alpha, \quad y = \rho \cos \beta, \quad z = \rho \cos \gamma. \quad (1)$$

$\cos \alpha, \cos \beta,$ and $\cos \gamma$ are called the **Direction Cosines** of the line OP . Hereafter we shall represent them by the letters $l, m,$ and $n,$ respectively. Then equations (1) become

$$x = l\rho, \quad y = m\rho, \quad z = n\rho. \quad (2)$$

It is to be carefully noticed that l, m, n are the direction cosines of a *directed line*; that if the signs of l, m, n are all changed, the

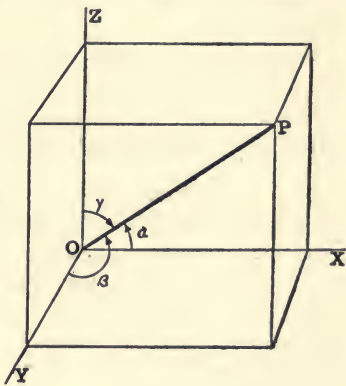

direction of the line is reversed. It is evident from equation (2) that the *signs* of l , m , and n for any line through the origin will be the same respectively as the *signs* of the rectangular coordinates x , y , and z of any point P on the line, provided OP be taken as the *positive* direction of the line. Hence we may always choose the polar coordinates of a point so that ρ shall be positive, and each of the angles α , β , γ shall be less than 180° .

The direction cosines of any line are evidently the same as the direction cosines of a parallel line through the origin, since parallel lines make the same angles with the axes.

Squaring and adding equations (2) we get

$$\rho^2(l^2 + m^2 + n^2) = x^2 + y^2 + z^2; \quad (3)$$

and, since $\rho^2 = x^2 + y^2 + z^2$, [(2), § 129] we have

$$l^2 + m^2 + n^2 = 1. \quad (4)$$

That is, *the sum of the squares of the direction cosines of any line is equal to unity.*

Hence the four polar coordinates of a point are equivalent to only three independent conditions.

If we divide each of the three numbers a , b , c by the square root of the sum of their squares, we get

$$\frac{a}{\sqrt{a^2 + b^2 + c^2}}, \frac{b}{\sqrt{a^2 + b^2 + c^2}}, \frac{c}{\sqrt{a^2 + b^2 + c^2}}. \quad (5)$$

Since these results are numbers which satisfy equation (4), they are the direction cosines of some line, whatever the values of a , b , c may be.

That is, *any three numbers are proportional to the direction cosines of some line.*

NOTE.—Custom is not uniform in regard to the use of the name *Polar Coordinates*. Many authors apply the name to the system described in § 132.

SPHERICAL COORDINATES

132. Let OX , OY , OZ , be a set of rectangular axes, and P any point. Then OP , or ρ , the angle θ which OP makes with OZ , and the angle ϕ which the plane ZOP makes with the fixed plane XOZ are the **Spherical Coordinates** of the point P , and are written (ρ, θ, ϕ) .

Since $OC = \rho \sin \theta$, the relations between rectangular and spherical coordinates are

$$\begin{aligned}x &= \rho \sin \theta \cos \phi, & y &= \rho \sin \theta \sin \phi, \\z &= \rho \cos \theta.\end{aligned}\quad (1)$$

Whence the relations between polar and spherical coordinates are found by equation (1) § 131 to be

$$\begin{aligned}\cos \alpha &= \sin \theta \cos \phi, & \cos \beta &= \sin \theta \sin \phi, \\ \gamma &= \theta.\end{aligned}\quad (2)$$

If P is a point on the surface of the earth and Z the pole, then θ is the *co-latitude* and ϕ the *longitude* of P . If P is a point on the celestial sphere and Z the pole, θ is the *co-declination* and ϕ the *right ascension* of P ; if Z is the zenith, then θ is the *zenith distance* and ϕ is the *azimuth* of P .

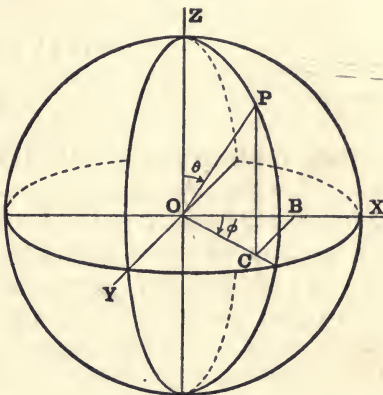

133. Cylindrical Coordinates.—If the position of the foot of the coordinate z in the plane xy is defined by the polar coordinates (ρ, θ) instead of (x, y) , then (ρ, θ, z) are called **Cylindrical Coordinates**.

EXAMPLES

1. Find the direction cosines of a line equally inclined to the three axes.
2. A line makes an angle of 60° with each of two axes. What angle does it make with the other axis?
3. If one direction angle of a line is 135° , another 120° , what is the third?
4. What are the direction cosines of a line perpendicular to the x -axis? the y -axis? the z -axis?
5. What are the direction cosines of a line parallel to the x -axis? the y -axis? the z -axis?
6. Find the direction cosines of the line joining the origin to the point $(3, -2, -1)$. Of the line joining the points $(-2, 4, 2)$ and $(1, 2, -4)$.
7. Find the direction cosines of the line joining the two points (x_1, y_1, z_1) and (x_2, y_2, z_2) .
8. Show that the square of the distance between the two points whose polar coordinates are $(\rho_1, \alpha_1, \beta_1, \gamma_1)$ and $(\rho_2, \alpha_2, \beta_2, \gamma_2)$ is

$$\rho_1^2 + \rho_2^2 - 2\rho_1\rho_2(\cos \alpha_1 \cos \alpha_2 + \cos \beta_1 \cos \beta_2 + \cos \gamma_1 \cos \gamma_2).$$

CHAPTER XIII

LOCI

134. We have seen in § 127 that $x = a$ is the equation of a plane parallel to the yz -plane; that $x = a, y = b$ are the equations of a line parallel to the z -axis; and that $x = a, y = b, z = c$ represent a point. So that here we have a plane represented by one equation, a straight line by two equations, and a point by three.

We shall now show that, in general, one equation represents a surface of some kind; two equations represent a line of some kind; and three equations represent one or more points.

Let the equation of the locus be $F(x, y, z) = 0$. We have seen that the equations of the line through the point $(a, b, 0)$ parallel to the z -axis are $x = a$, and $y = b$. Hence, if we put $x = a$, and $y = b$ in the equation of the locus, we get the equation $F(a, b, z) = 0$, which must be satisfied by the coordinates of all points common to this line and the locus. Let the roots of this equation be z_1, z_2 , etc. Then the locus is met by this line in the points $(a, b, z_1), (a, b, z_2)$, etc. Since, in general, the number of roots of the equation $F(a, b, z) = 0$ is finite, the straight line will meet the locus in a finite number of points. Hence the locus, which is the assemblage of all such points found by assigning different values to a and b , is a *surface* and not a solid figure.

If the coordinates of a point (x, y, z) satisfy two equations $F(x, y, z) = 0$ and $\phi(x, y, z) = 0$, simultaneously, the point must be on both of the surfaces which these equations represent. Therefore the locus is the *curve* determined by the intersection of the two surfaces. When three equations are used simultaneously, they are sufficient to determine absolutely the values of the unknown quantities x, y, z . Hence three equations represent one or more points.

135. *Equations involving only one or two variables.*

If an equation contains only *one* variable, x say, let it be put in the form $\phi(x) = 0$. We know that this equation is equivalent to $(x - a)$

$(x - b)(x - c) \dots = 0$, where a, b, c, \dots are roots of $\phi(x)$. Hence such an equation represents one or more planes parallel to the coordinate plane $x = 0$.

Let only one of the variables be absent, so that the equation is of the form $F(x, y) = 0$. Let $P(x, y, 0)$ be any point in the xy -plane whose coordinates satisfy the equation $F(x, y) = 0$. Draw a line through P parallel to the z -axis. Then all points on this line have the same x and y as P . That is, they are all on the surface. Hence the locus of the equation $F(x, y) = 0$ is the cylindrical surface, or cylinder, traced out by a line which is always parallel to the z -axis, and which moves along the curve in the xy -plane defined by the equation $F(x, y) = 0$. In like manner the equations $f(y, z) = 0$ and $\phi(z, x) = 0$ represent cylinders whose elements are parallel to the x -axis and y -axis, respectively.

If we treat the two equations $F(x, y, z) = 0$ and $f(x, y, z) = 0$ simultaneously and eliminate z , we obtain an equation of the form $\phi(x, y) = 0$. This equation is satisfied by the coordinates of all points on the *curve* represented by the two given equations. Since $\phi(x, y) = 0$ contains only two variables, it represents a cylinder through this curve having its elements perpendicular to the xy -plane. Or, interpreted as an equation in plane coordinates, it represents the projection of this curve on the xy -plane. Similarly, by eliminating x and y we can find the projections of the curve on the other two coordinate planes.

It is often convenient and desirable to represent a curve by means of the equations of two of its projecting cylinders.

If, however, we eliminate z between $F(x, y, z) = 0$ and the equation of the plane $z = k$, we obtain the equation $F(x, y, k) = 0$. This equation also represents a projecting cylinder through the intersection of the surface and the plane $z = k$; but in the plane $z = 0$ it represents a curve equal in all respects to the plane section of the surface, since the plane of the section $z = k$ is parallel to the plane $z = 0$, on which the curve is projected.

The curves of intersection of a surface with the coordinate planes are called the **Traces** of the surface. Their equations may be found by putting x, y, z in turn equal to zero in the equation of the surface. These curves are very useful in determining the nature of the surface.

TO TRACE THE LOCUS OF AN EQUATION

136. Contour Lines.—A *Topographical Map* is one which gives not only the geographical position of objects on the surface of the ground, but also the relative elevations of the different parts of the surface. On such a map the configuration of the surface is represented by means of *Contour Lines*. A contour line is the projection on the plane of the paper of the intersection of a horizontal, or rather *level*, plane with the surface of the ground. These cutting level planes are taken 5, 10, 20, 50, or 100 feet apart vertically, beginning with the *datum plane*, which is usually taken below any point in the surface of the region included in the map.

The following principles will assist in interpreting the meaning of contour lines: All points in one contour line have the same elevation above the datum plane. Where ground is uniformly sloping the contours must be equi-spaced for equal changes in elevation, and where it is a plane they are also straight and parallel. In general contour lines never intersect or cross each other. Two exceptions to this rule should be carefully noted, viz. a contour line will cross itself at a pass, they cross each other at overhanging precipices. Every contour line must either close upon itself or extend continuously across the map. Where a contour line closes upon itself the included area is either a hill-top or a depression without an outlet.

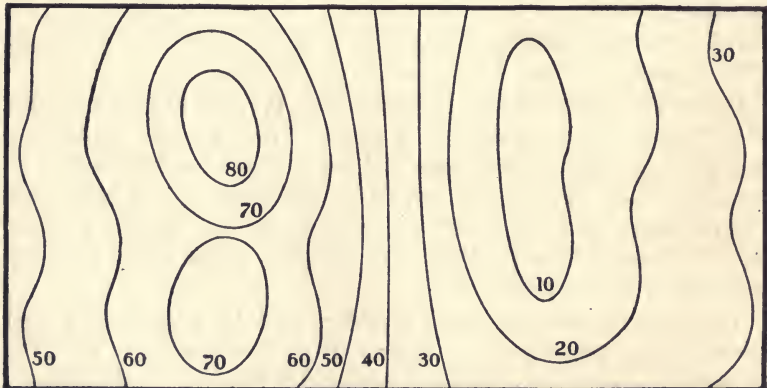

What is the nature of the surface shown by the contour lines in this figure ?

It is obvious that this method of contours can be used to determine the general nature of the surface represented by any given equation $F(x, y, z) = 0$. If we put $z = k$ in this equation we get the equation $F(x, y, k) = 0$, which represents the projection on the plane $z = 0$ of any plane section of the given surface parallel to this coordinate plane. By assigning different values to k we can get as many such sections as we choose. In like manner, by putting $x = k$, and $y = k$, we can find sections parallel to the other coordinate planes. We may for convenience call these sections *contours* of the given surface. These three systems of contours will indicate the general nature of the surface.

Find the contours of the surfaces whose equations are

$$1. \ x + y + z = 1. \qquad 2. \ x^2 + y^2 + z^2 = a^2. \qquad 3. \ x^2 + y^2 = c^2.$$

137. *An equation of the first degree represents a plane.*

The most general equation of the first degree is

$$Ax + By + Cz + D = 0. \qquad (1)$$

If we put $z = k$ in this equation, we get

$$Ax + By + Ck + D = 0, \qquad (2)$$

which for different values of k represents a system of parallel straight lines. The contours on the planes yz and zx are also parallel straight lines.

The distance between the two contours made by the planes $z = k_1$ and $z = k_2$ is $\frac{C(k_1 - k_2)}{\sqrt{A^2 + B^2}}$. But this distance varies directly as $(k_1 - k_2)$, the distance between the two planes $z = k_1$ and $z = k_2$. Therefore equation (1) represents a plane.

138. *Trace the surface represented by the equation*

$$x^2 + y^2 + z^2 + 2Ax + 2By + 2Cz + D = 0. \qquad (1)$$

The xy -contours of this surface are the concentric circles

$$x^2 + y^2 + 2Ax + 2By + k^2 + 2Ck + D = 0, \qquad (2)$$

with centres at $(-A, -B)$ and radii equal to

$$\sqrt{A^2 + B^2 - (k^2 + 2Ck + D)},$$

which become zero if $k = -C \pm \sqrt{A^2 + B^2 + C^2 - D}$, and imaginary

if $k > -C + \sqrt{A^2 + B^2 + C^2 - D}$,

or if $k < -C - \sqrt{A^2 + B^2 + C^2 - D}$.

The xz -contours are circles whose equations may be written

$$(x + A)^2 + (z + C)^2 = A^2 + C^2 - (k^2 + 2Bk + D). \quad (3)$$

Likewise the yz -contours are circles whose equations are

$$(y + B)^2 + (z + C)^2 = B^2 + C^2 - (k^2 + 2Ak + D). \quad (4)$$

Moreover, the centres of these three systems of concentric circles are the projections of the point $(-A, -B, -C)$, and the radius of each system is $\sqrt{A^2 + B^2 + C^2 - D}$ when k is equal respectively to $-C, -B$, and $-A$. Hence these contours indicate that the surface is a sphere with centre at the point $(-A, -B, -C)$ and radius equal to $\sqrt{A^2 + B^2 + C^2 - D}$. This can be shown to be true by writing the given equation (1) in the form

$$(x + A)^2 + (y + B)^2 + (z + C)^2 = A^2 + B^2 + C^2 - D, \quad (5)$$

and comparing with equation (1) § 129.

Hence the equation of the sphere whose centre is the point (a, b, c) and radius r is

$$(x - a)^2 + (y - b)^2 + (z - c)^2 = r^2. \quad (6)$$

If the centre is at the origin, the equation is

$$x^2 + y^2 + z^2 = r^2. \quad (7)$$

139. Trace the surface whose equation is [Frost's S. G. p. 5.]

$$(x + y)^2 = az.$$

When $x = 0$, $y^2 = az$; therefore the trace on the yz -plane is a parabola OQ , whose axis is OZ and vertex O .

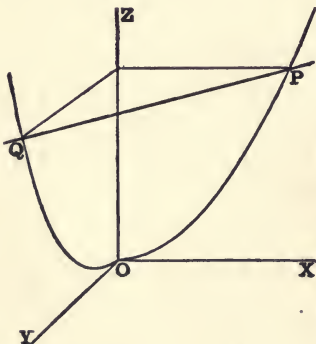

Similarly the trace OP on the xz -plane is the equal parabola $x^2 = az$, having the same vertex and axis.

If $z = k$, $(x + y)^2 = ak$. That is, any xy -contour is two parallel straight lines, equally inclined to the x and y -axes.

Hence the surface is a cylinder generated by a straight line PQ moving along the two equal parabolas $y^2 = az$ and $x^2 = az$, and always parallel to the straight line $x + y = 0$ in the xy -plane.

The other two systems of contours are parabolas which are all equal to the traces OP and OQ .

EXAMPLES

Trace the surfaces represented by the following equations:

1. $2x + 3y - 4z = 12.$
2. $x^2 + y^2 + z^2 = 16.$
3. $x^2 + y^2 + z^2 - 4x + 6y - 2z = 11.$
4. $x^2 + z^2 = a^2.$
5. $y^2 + z^2 = 2az.$
6. $y^2 = 4az.$
7. $z^2 - y^2 = a^2.$
8. $x^2 + y^2 = z^2.$
9. $x^2 + y^2 = az.$
10. $\frac{y^2}{a^2} + \frac{z^2}{b^2} = 4x^2.$
11. $\frac{x^2}{a^2} + \frac{y^2}{b^2} = 4z.$
12. $z^2 = ax + by.$
13. $\frac{x^2}{a^2} + \frac{y^2}{b^2} + \frac{z^2}{c^2} = 1.$
14. $\frac{x^2}{a^2} + \frac{y^2}{b^2} - \frac{z^2}{c^2} = 1.$
15. $\frac{x^2}{a^2} - \frac{y^2}{b^2} - \frac{z^2}{c^2} = 1.$
16. $(x + y)^2 + z^2 = a^2.$
17. $y^2 = 2xz.$
18. $(x + y)^2 = 2(a^2 - z^2).$
19. $(x + y - a)^2 + z^2 = a^2.$
20. $(x - z)^2 + (y - z)^2 = a^2.$
21. $(x + y)^2 = c(z - x).$
22. $c^2y^2 = x^2(a^2 - z^2).$
23. $xz^2 = c^2y.$
24. $xy = az.$
25. $y = x \tan z.$
26. $xyz = a.$

Show that the following pairs of equations represent the same locus, and trace their loci:

27. $\rho = a \cos \theta$ and $x^2 + y^2 + z^2 = az.$
28. $\rho = a \sin \theta$ and $(x^2 + y^2 + z^2)^2 = a^2(x^2 + y^2).$
29. $\rho = a \cos \phi$ and $(x^2 + y^2 + z^2)(x^2 + y^2) = a^2x^2.$
30. $\rho = a \sin \phi$ and $(x^2 + y^2 + z^2)(x^2 + y^2) = a^2y^2.$

TO FIND THE EQUATION OF A LOCUS

140. If a point moves in space subject to a given condition, it will generate a locus. This locus is the *totality of positions* the point may have under the given condition. For example, a point keeping at a constant distance from a fixed plane will generate a parallel plane; a point keeping at a constant distance from a fixed straight line will generate a cylinder. If we can find, in any system of coordinates, an algebraic equation that is satisfied by the coordinates of every point on the locus, and not satisfied by the coordinates of any other point, we shall have, as in plane geometry, the equation of the locus.

In the second example just cited, for instance, if the z -axis is taken as the fixed line and a as the constant distance, the equation of the locus will be $x^2 + y^2 = a^2$; for this equation is satisfied by the coordinates of any point (x, y, z) whose distance from the z -axis is a , and by no other point.

In finding the equation of a locus in space, the general method of procedure is the same as in plane geometry.

SURFACES OF REVOLUTION

141. A *Surface of Revolution* is a surface generated by revolving a plane curve around a fixed line in the plane of the curve.

To find the general equation of a surface of revolution we will take the x -axis for the fixed line, and let the equation of the generating curve be

$$y = f(x). \quad (1)$$

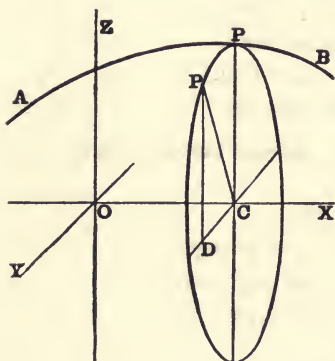

Any point P on the generating curve AB will describe a circle whose plane is perpendicular to the x -axis, and whose radius is CP , the ordinate of the generating curve. Hence for every point $P(x, y, z)$ on this circle we have

$$y^2 + z^2 = CP^2. \quad (2)$$

For all positions of P on the generating curve

$$CP = f(x). \quad (3)$$

Therefore the required equation is

$$y^2 + z^2 = [f(x)]^2. \quad (4)$$

Similarly, the equations of surfaces of revolution about the other two coordinate axes are

$$x^2 + z^2 = [f(y)]^2 \text{ and } x^2 + y^2 = [f(z)]^2. \quad (5)$$

For example, if the circle $x^2 + y^2 = r^2$ is revolved about the x -axis, we have $CP = \sqrt{r^2 - x^2} \equiv f(x)$; and the equation of the generated sphere is $x^2 + y^2 + z^2 = r^2$.

Likewise the equation of the cone generated by revolving the line $y = mx$ about the x -axis is

$$y^2 + z^2 = m^2 x^2. \quad (6)$$

If we eliminate z between this equation (6) and the equation of the plane $z = m'x + c$ we get for the projection of the conic section on the xy -plane

$$y^2 + (m'^2 - m^2)x^2 + 2cm'x + c^2 = 0. \quad (7)$$

Show that this section is an ellipse, a parabola, or a hyperbola according as $m' >, =, \text{ or } < m$; and that if $c = 0$, it is either a point, two coincident lines, or two intersecting lines. What property of the conic section does this prove?

EXAMPLES

1. Show that the locus of all points in space equally distant from the two points $(3, -2, 1)$ and $(-2, 1, -3)$ is the plane $5x - 3y + 4z = 0$.

2. Show that all points which are equidistant from the three points $(4, -1, -2)$, $(-2, 4, -1)$, and $(-1, -2, 4)$ are on the line whose equations are $x = y = z$.

3. A point moves so that its distance from the origin is twice its distance from the plane $z = 0$. Find the locus of the point. *Ans.* $x^2 + y^2 = 3z^2$.

4. Find the locus of a point which moves so that (1) the sum, (2) the difference of the squares of its distances from the points $(a, 0, 0)$ and $(-a, 0, 0)$ is the constant $2c^2$.

5. Find the locus of a point such that the sum of the squares of its distances from the three points $(3, -3, 5)$, $(-1, 1, -2)$, and $(4, 2, -3)$ is 38.

$$\text{Ans. } x^2 + y^2 + z^2 - 4x + 26 = 0.$$

6. Show that the locus of a point the sum of the squares of whose distances from n fixed points is constant is a sphere.

7. Find the locus of a point such that the sum of the squares of its distances from the faces of a cube is constant.

8. Find the equations of the surfaces of revolution generated by revolving the conic sections around their axes.

9. Find the equation of the surface generated by revolving the parabola around the tangent at the vertex.

10. Find the locus of a point which moves so that its distance from the point $(2a, 0, 0)$ is always equal to its distance from the plane $x = 0$.

11. Find the locus of a point such that (1) the sum, and (2) the difference, of its distances from the two points $(c, 0, 0)$ and $(-c, 0, 0)$ is constant and equal to $2a$.

12. Show that the equation of the surface generated by revolving the circle $x^2 + z^2 = 2ax$ around the z -axis is

$$(x^2 + y^2 + z^2)^2 = 4a^2(x^2 + y^2).$$

Show also that the equation in spherical coordinates is

$$\rho = 2a \sin \theta. \quad (\text{See Ex. 28, p. 205.})$$

13. The six points $A(a, 0, 0)$, $B(-a, 0, 0)$, $C(0, a, 0)$, $D(0, -a, 0)$, $E(0, 0, a)$, and $F(0, 0, -a)$ form a regular octahedron.

Find the locus of a point P in space such that

- (1) $AP^2 + BP^2 + EP^2 = CP^2 + DP^2 + FP^2$; *Ans.* $z = 0$.
- (2) $AP^2 + CP^2 + EP^2 = BP^2 + DP^2 + FP^2$; *Ans.* $x + y + z = 0$.
- (3) $AP^2 + CP^2 = BP^2 + DP^2 + EP^2 + FP^2$; *Ans.* $x^2 + y^2 + z^2 + 2a(x + y) + a^2 = 0$.
- (4) $AP^2 + BP^2 = CP^2 + DP^2 + EP^2 + FP^2$; *Ans.* $x^2 + y^2 + z^2 + a^2 = 0$.
- (5) $AP^2 + BP^2 = CP^2 + DP^2 = EP^2 + FP^2$; *Ans.* All space.

14. If $ABCD$ is a regular tetrahedron, show that the locus of a point P , such that $2PA^2 = PB^2 + PC^2 + PD^2$, is a sphere passing through the points, B, C, D , and having a radius equal to twice the face altitude of the tetrahedron.

15. Show that the equation $S + \lambda S' = 0$ represents a surface passing through all the common points of the two surfaces $S = 0$ and $S' = 0$. Show also that $SS' = 0$ represents both of the surfaces $S = 0$ and $S' = 0$.

16. Find the equation of the surface of the blade of a screw-auger.

CHAPTER XIV

THE PLANE AND THE STRAIGHT LINE

142. *To find the equation of a plane.*

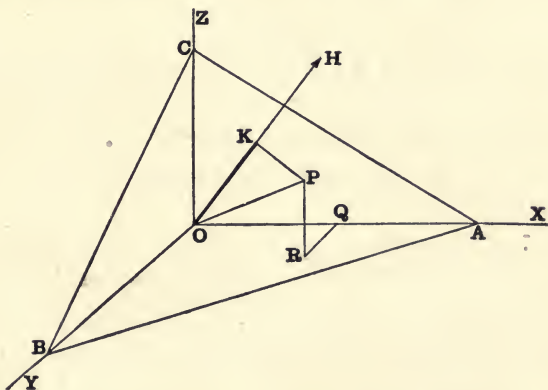

Let OH be perpendicular to the given plane ABC , intersecting it in K ; and let l, m, n be the direction cosines of OH . Let $OK = p$ be the distance measured from the origin to the plane, and let $P(x, y, z)$ be any point in the plane. Draw PR perpendicular to the plane XOY and RQ perpendicular to OX .

Then OK , the projection of OP on OH , is equal to the sum of the projections of OQ, QR , and RP on OH . [(1), § 130]

Therefore $lx + my + nz = p$, (1)

which is the equation of the plane in the *Normal* or *Distance Form*.

Since changing the signs of all its direction cosines reverses the direction of a line, the equation of a plane may always be written so that p shall be measured along the positive direction of OH ; i.e. so that p shall be positive. The positive side of the plane is

found by going from the plane in the positive direction of p . Hence when p is *positive* the origin is on the *negative* side of the plane.

Equation (1) may also be written in the form

$$\frac{x}{\frac{p}{l}} + \frac{y}{\frac{p}{m}} + \frac{z}{\frac{p}{n}} = 1. \quad (2)$$

If now we let $a = \frac{p}{l}$, $b = \frac{p}{m}$, and $c = \frac{p}{n}$, we have

$$\frac{x}{a} + \frac{y}{b} + \frac{z}{c} = 1, \quad (3)$$

which is the equation of the plane in terms of its intercepts on the axes.

The general equation of the first degree

$$Ax + By + Cz + D = 0 \quad (4)$$

may be written

$$\frac{Ax}{\sqrt{A^2+B^2+C^2}} + \frac{By}{\sqrt{A^2+B^2+C^2}} + \frac{Cz}{\sqrt{A^2+B^2+C^2}} = \frac{-D}{\sqrt{A^2+B^2+C^2}}, \quad (5)$$

in which the coefficients of x , y , and z are the direction cosines of some line [(5), § 131]. Comparing this with equation (1) we see that (5) is the equation of a plane in the *distance form*.

143. The distance from a given plane to a given point.

The demonstration is precisely the same as that for the corresponding proposition in Plane Geometry.

If d represents the distance and (x_1, y_1, z_1) is the given point, the required formula is

$$d = lx_1 + my_1 + nz_1 - p, \text{ or } d = \frac{Ax_1 + By_1 + Cz_1 + D}{\sqrt{A^2 + B^2 + C^2}}, \quad (1)$$

according as the equation of the plane is

$$lx + my + nz = p, \text{ or } Ax + By + Cz + D = 0.$$

As in Plane Geometry a point (x', y', z') is on the *positive* or *negative* side of the plane $Ax + By + Cz + D = 0$, according as $Ax' + By' + Cz' + D$ is *positive* or *negative*.

EXAMPLES

1. Show that the equation of a plane through the three points (x_1, y_1, z_1) , (x_2, y_2, z_2) , and (x_3, y_3, z_3) is

$$\begin{vmatrix} x, & y, & z, & 1 \\ x_1, & y_1, & z_1, & 1 \\ x_2, & y_2, & z_2, & 1 \\ x_3, & y_3, & z_3, & 1 \end{vmatrix} = 0.$$

2. Find the equation of the plane through the three points $(1, 2, 2)$, $(2, -4, -3)$, and $(-5, 2, 5)$. Find p , the intercepts, and traces of the plane.

$$\text{Ans. } 2x - 3y + 4z = 4.$$

3. Find the equation of the plane through the point $(3, 2, -4)$ parallel to the plane $2x - 3y - 5z = 0$.

$$\text{Ans. } 2x - 3y - 5z = 20.$$

4. If $S = 0$ and $S' = 0$ are the equations of two planes, show that $S + \lambda S' = 0$ will be the general equation of a plane through their intersection.

5. Find the equation of a plane through the origin and through the intersection of the two planes $3x + 4y - 2z + 4 = 0$ and $4x - 5y - z = 6$.

$$\text{Ans. } 17x + 2y - 8z = 0.$$

6. Show that the four planes $x - y - 2z = 1$, $2x - y + z + 1 = 0$, $x + 2y - z = 6$, and $4x + y + 6z = 0$ meet in a point.

Find the general condition that four planes shall meet in a point.

7. Show that the four points $(0, 1, 3)$, $(1, 1, 1)$, $(-2, -3, -5)$, and $(4, 2, -2)$ are in the same plane. (Use the determinant in Ex. 1.)

8. Show that the two points $(1, -4, -2)$ and $(-1, 2, 3)$ are on opposite sides of the plane $7x - 3y + 4z = 5$, and equidistant from it.

9. Show that the equations of the planes which bisect the angles between the two planes $Ax + By + Cz + D = 0$ and $A'x + B'y + C'z + D' = 0$,

are

$$\frac{Ax + By + Cz + D}{\sqrt{A^2 + B^2 + C^2}} = \pm \frac{A'x + B'y + C'z + D'}{\sqrt{A'^2 + B'^2 + C'^2}}.$$

144. Equations of a straight line.

We have seen in § 134 that it requires two equations used simultaneously to represent a line in space. Since two planes intersect in a straight line we may take the two general equations of the first degree

$$Ax + By + Cz + D = 0, \text{ and } A'x + B'y + C'z + D' = 0, \quad (1)$$

as the most general equations of a straight line.

If we treat these equations simultaneously and eliminate z, y, x ,

respectively, we obtain three other consistent equations which may be reduced to the form

$$\frac{x}{a} + \frac{y}{b} = 1, \quad \frac{y}{b'} + \frac{z}{c} = 1, \quad \frac{z}{c'} + \frac{x}{a'} = 1. \quad (2)$$

Since each of these equations (2) is satisfied by the coordinates of every point on the line, they will each determine a plane through the line. These planes are seen to be the projecting planes of the line, while their equations also represent the projections of the line on the coordinate planes. The equations of any two of the projecting planes may be chosen as the equations of the line.

If the line is parallel to one of the coordinate planes, two of the projecting planes coincide and the equations of the line will be of the form $bx + ay = ab, z = c$; if the line is parallel to one of the axes, one of the projecting planes is indeterminate, and the other two are of the form $x = a, y = b$.

From the equations (2) of the projecting planes we see that the coordinates of the points where the line meets the coordinate planes $x = 0, y = 0, z = 0$, are respectively $(0, b, c)$, $(a, 0, c)$, $(a', b', 0)$.

The equations of a straight line contain four independent constants.

145. The symmetrical equations of a straight line.

Let $P'(x', y', z')$ be a fixed point on the line, and $P(x, y, z)$ any other point on the line at a distance r from P' ; let l, m, n be the direction cosines of the line $P'P$.

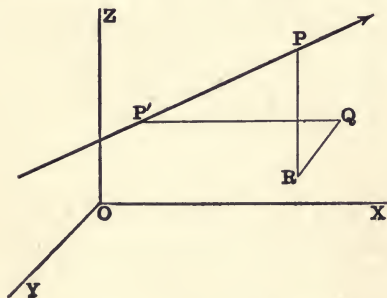

Through P' and P draw planes parallel to the coordinate planes, making a parallelepiped whose edges $P'Q, QR$, and RP are respectively equal to the projections of $P'P$, or r , on the axes. Since these edges are respectively equal to $x - x', y - y',$ and $z - z'$, we have

$$x - x' = lr, \quad y - y' = mr, \quad z - z' = nr, \quad (\S 130) \quad (1)$$

or

$$\frac{x - x'}{l} = \frac{y - y'}{m} = \frac{z - z'}{n} = r, \quad (2)$$

which are the required equations of the line.

146. To find the equations of a straight line through two given points (x_1, y_1, z_1) and (x_2, y_2, z_2) .

Since the line passes through the point (x_1, y_1, z_1) its equations will be of the form [(2), § 145]

$$\frac{x - x_1}{l} = \frac{y - y_1}{m} = \frac{z - z_1}{n}. \quad (1)$$

Then, since the point (x_2, y_2, z_2) is also on the line, we have

$$\frac{x_2 - x_1}{l} = \frac{y_2 - y_1}{m} = \frac{z_2 - z_1}{n}. \quad (2)$$

Dividing (1) by (2) gives the required equations,

$$\frac{x - x_1}{x_2 - x_1} = \frac{y - y_1}{y_2 - y_1} = \frac{z - z_1}{z_2 - z_1}. \quad (3)$$

Hence, the direction cosines of the line are proportional to the differences of the coordinates of the two given points.

147. The equations of any two straight lines in rectangular coordinates can be written in a very simple form by a proper choice of axes.

Take the middle point of the shortest distance between the two lines for the origin, and the z -axis along this line. Take the yz and xz planes so that they bisect the angles between the two planes determined by the z -axis and the two given lines. Then the equations of the two lines can be written

$$y = mx, \quad z = c, \quad \text{and} \quad y = -mx, \quad z = -c, \quad (1)$$

or in the symmetric form

$$\frac{x}{1} = \frac{y}{m} = \frac{z - c}{0}, \quad \text{and} \quad \frac{x}{1} = \frac{y}{-m} = \frac{z + c}{0}. \quad (2)$$

EXAMPLES

1. Find the symmetric equations, and the direction cosines, of the line of intersection of the planes $5x - y + z + 5 = 0$ and $x - y - z + 1 = 0$.

Eliminating z and y in turn between these equations, we get

$$3x = y - 3 \quad \text{and} \quad 2x + z + 2 = 0.$$

Whence

$$\frac{x}{1} = \frac{y - 3}{3} = \frac{z + 2}{-2}.$$

Hence the direction cosines of the line are proportional to 1, 3, and -2 ; and their actual values are $\frac{1}{\sqrt{14}}$, $\frac{3}{\sqrt{14}}$, $\frac{-2}{\sqrt{14}}$.

Find the projections, the symmetric equations, the points where they pierce the coordinate planes, and the direction cosines of the lines whose equations are

2. $x + y - z + 1 = 0$ and $4x + y + z = 5$.
3. $x + y - z + 1 = 0$ and $4x + y - 2z + 2 = 0$.
4. $2x - y + z - 3 = 0$ and $x + 2y + z = 5$.
5. $3x - 2y + 4z = 12$ and $6x - 4y - 3z + 24 = 0$.
6. $5x - 3y + 2z + 5 = 0$ and $3x - 5y - 2z = 7$.

7. Write the symmetric equations of a line perpendicular to a coordinate axis; a coordinate plane.

8. Write the symmetric equations of the line through the point $(2, -3, 1)$ equally inclined to the axes.

9. Find the equations and direction cosines of the line through the two points $(-1, 3, 2)$ and $(2, -3, 0)$.

10. Find the equations of the line through the origin perpendicular to the plane $lx + my + nz = p$.

11. Find the coordinates of the point where the line $\frac{x-2}{1} = \frac{y-2}{-2} = \frac{z+3}{-3}$ meets the plane $2x - y - 3z + 15 = 0$.

148. To find the angle between two straight lines whose direction cosines are given.

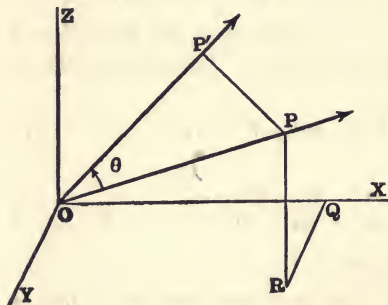

Draw OP and OP' through the origin parallel respectively to the two given lines. Let l, m, n and l', m', n' be the direction cosines of OP and OP' respectively, and let θ represent the angle POP' .

Let ρ be the distance from the origin to the point $P(x, y, z)$. Then projecting $\rho, x, y,$ and z on OP' we get [(1), § 130]

$$\rho \cos \theta = l'x + m'y + n'z. \quad (1)$$

But $x = l\rho, y = m\rho,$ and $z = n\rho.$ [(2), § 131.] (2)

$$\therefore \cos \theta = ll' + mm' + nn'. \quad (3)$$

If $\theta = 90^\circ,$ $\cos \theta = 0.$ Hence the condition for perpendicularity is

$$ll' + mm' + nn' = 0. \quad (4)$$

It should be noticed that equation (3) gives the angle between two lines directed from the origin. If the signs of l, m, n are all changed, the direction of OP will be reversed, the sign of $l'l' + mm' + nn'$ will be changed, and θ will be the supplement of its former value. But if the signs of $l' m' n'$ are also changed, the direction of both lines will be reversed, the sign of $\cos \theta$ will not be changed, and θ will be unaltered.

149. *To find the angle between two planes.*

The angles between two planes are evidently equal to the angles between the lines through the origin perpendicular to the planes.

Let the equations of the planes in the distance form be

$$lx + my + nz = p, \quad (1)$$

and $l'x + m'y + n'z = p'. \quad (2)$

Then $\cos \theta = \frac{W + mm' + nn'}{[(3), \text{§ 148.}]} \quad (3)$

If the planes are at right angles, $\cos \theta = 0$; i.e.

$$W + mm' + nn' = 0. \quad (4)$$

If $l = l', m = m',$ and $n = n',$ then $\cos \theta = 1,$ and the planes are parallel.

If the equations of the planes are

$$Ax + By + Cz + D = 0, \quad (5)$$

and $A'x + B'y + C'z + D' = 0, \quad (6)$

$$\cos \theta = \frac{AA' + BB' + CC'}{\sqrt{A^2 + B^2 + C^2} \cdot \sqrt{A'^2 + B'^2 + C'^2}}; \quad [(5), \text{§ 142}] \quad (7)$$

and the condition for perpendicularity is

$$AA' + BB' + CC' = 0. \quad (8)$$

If $A = kA', B = kB'$ and $C = kC',$ the planes are parallel.

Let the equations (1) and (2) be written so that p and p' have the same sign. Then, when $\cos \theta$ is positive the angle between p and p' is acute, and the angle between the planes in which the origin lies is obtuse. If $\cos \theta$ is negative, the origin lies in the acute angle between the planes.

EXAMPLES

1. Show that the lines $4x = -y = 3z$ and $3x = -4y = -z$ are perpendicular to each other.

2. Find the angle between the lines $\frac{x}{1} = \frac{y}{3} = \frac{z}{4}$ and $\frac{x}{3} = \frac{y}{-4} = \frac{z}{1}$.

$$\text{Ans. } \cos^{-1} \frac{5}{26}.$$

3. Find the angle between any two of the four lines through the origin equally inclined to the axes.

4. Find the angle between any two of the lines which bisect the angles between the axes.

5. Find the angle between one of the lines in Ex. 3 and one of the lines in Ex. 4.

6. Find the angle between the planes $x + y + z = 1$ and $x - y - 2z = 2$. Is the origin in the acute or the obtuse angle? the point $(1, 3, -1)$?

$$\text{Ans. } \cos^{-1} \frac{\sqrt{2}}{3}, \text{ Acute, Obtuse.}$$

7. Find the equation of the plane through the line $x + y - z = 2$, $2x - 3y + 4z + 5 = 0$ and perpendicular to the plane $x - 2y + z = 0$.

$$\text{Ans. } 8x + 3y - 2z = 7.$$

8. Find the equation of the line through the point $(1, 4, 3)$ perpendicular to the plane $3x - 2y + 4z = 0$.

9. Find the equation of the plane through the point $(2, -1, 3)$ and perpendicular to the line $2x + 3y - z = 2$, $x - 2y + z = 3$.

$$\text{Ans. } x - 3y - 7z + 16 = 0.$$

10. Find the dihedral angles of a regular octahedron.

11. Show that the line $\frac{x}{l} = \frac{y}{m} = \frac{z}{n}$ will be parallel to the plane

$$l'x + m'y + n'z = p, \text{ if } ll' + mm' + nn' = 0.$$

12. Show that the equations of the straight lines which bisect the angles between the lines

$$\frac{x}{l} = \frac{y}{m} = \frac{z}{n} \quad \text{and} \quad \frac{x}{l'} = \frac{y}{m'} = \frac{z}{n'}.$$

are $\frac{x}{l+l'} = \frac{y}{m+m'} = \frac{z}{n+n'}$ and $\frac{x}{l-l'} = \frac{y}{m-m'} = \frac{z}{n-n'}$.

TRANSFORMATION OF COORDINATES

150. *To change the origin of coordinates without changing the direction of the axes.*

This transformation is evidently similar to the corresponding one in Plane Geometry. Hence if we wish to find the equation of a locus referred to new axes parallel respectively to the old, and passing through the point (x_0, y_0, z_0) , we have only to write in the place of x, y, z , respectively,

$$x + x_0, y + y_0, z + z_0.$$

151. *To change the direction of the axes without changing the origin.*

Let l_1, m_1, n_1 ; l_2, m_2, n_2 ; and l_3, m_3, n_3 be the direction cosines of the new axes OX', OY', OZ' respectively, referred to the old axes.

Let P be any point (x, y, z) referred to the old axes, and let its coordinates referred to the new axes be $OQ = x', QR = y', RP = z'$.

Then projecting the lines OP, x', y', z' on the old axes OX, OY, OZ , respectively, we get [(1), § 130]

$$\left. \begin{aligned} x &= l_1x' + l_2y' + l_3z', \\ y &= m_1x' + m_2y' + m_3z', \\ \text{and } z &= n_1x' + n_2y' + n_3z'. \end{aligned} \right\} (1)$$

These are the required formulæ.

The student should compare them with the corresponding formulæ in Plane Geometry.

It is evident that the degree of an equation will not be altered by either of these transformations.

The direction cosines of the old axes referred to the new are respectively l_1, l_2, l_3 ; m_1, m_2, m_3 ; and n_1, n_2, n_3 .

Hence we have the six relations

$$\left. \begin{aligned} l_1^2 + m_1^2 + n_1^2 &= 1, \\ l_2^2 + m_2^2 + n_2^2 &= 1, \\ l_3^2 + m_3^2 + n_3^2 &= 1; \end{aligned} \right\} (2)$$

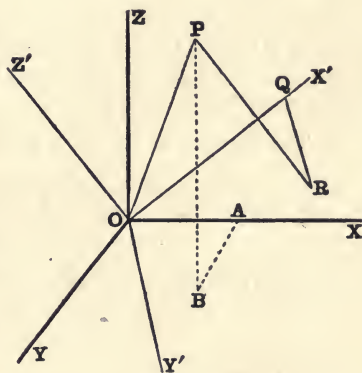

$$\left. \begin{aligned} l_1^2 + l_2^2 + l_3^2 &= 1, \\ m_1^2 + m_2^2 + m_3^2 &= 1, \\ n_1^2 + n_2^2 + n_3^2 &= 1. \end{aligned} \right\} \quad (3)$$

Since both sets of axes are rectangular, we also have the six equations

$$\left. \begin{aligned} l_1 l_2 + m_1 m_2 + n_1 n_2 &= 0, \\ l_2 l_3 + m_2 m_3 + n_2 n_3 &= 0, \\ l_3 l_1 + m_3 m_1 + n_3 n_1 &= 0; \end{aligned} \right\} \quad (4)$$

$$\left. \begin{aligned} l_1 m_1 + l_2 m_2 + l_3 m_3 &= 0, \\ m_1 n_1 + m_2 n_2 + m_3 n_3 &= 0, \\ n_1 l_1 + n_2 l_2 + n_3 l_3 &= 0. \end{aligned} \right\} \quad (5)$$

EXAMPLES ON CHAPTER XIV

1. Transform the equation $(x + y)^2 = az$ by turning the axes of x and y around the z -axis through an angle of 45° . *Ans.* $2x^2 = az$.

2. If P is a fixed point on a straight line through the origin equally inclined to the axes, any plane through P will intercept lengths on the axes the sum of whose reciprocals is constant.

3. The equation of the plane through the line $\frac{x}{l} = \frac{y}{m} = \frac{z}{n}$, and which is perpendicular to the plane containing the lines $\frac{x}{m} = \frac{y}{n} = \frac{z}{l}$ and $\frac{x}{n} = \frac{y}{l} = \frac{z}{m}$, is

$$(m - n)x + (n - l)y + (l - m)z = 0.$$

4. Show that the three straight lines

$$\frac{x}{\alpha} = \frac{y}{\beta} = \frac{z}{\gamma}, \quad \frac{x}{a} = \frac{y}{b} = \frac{z}{c}, \quad \frac{x}{l} = \frac{y}{m} = \frac{z}{n},$$

will lie in one plane if

$$\alpha(bn - cm) + \beta(cl - an) + \gamma(am - bl) = 0.$$

5. If a, b, c and a', b', c' are the intercepts of a plane on two sets of rectangular axes having the same origin, then

$$\frac{1}{a^2} + \frac{1}{b^2} + \frac{1}{c^2} = \frac{1}{a'^2} + \frac{1}{b'^2} + \frac{1}{c'^2}.$$

6. The locus of a point whose distances from two given planes are in a constant ratio is a plane.

7. Show that the locus of a point which moves so that the sum of its distances from two fixed planes is constant is a plane parallel to one of the planes which bisect the angles between the two fixed planes. What is the locus if the difference of these distances is constant?

8. Find the locus of a point which moves so that the sum of its distances from any number of planes is constant.

9. Transform the equation $z^2 = ax + by$ by turning the axes of x and y around the z -axis until the new y -axis coincides with the line $ax + by = 0, z = 0$.

$$\text{Ans. } z^2 = x\sqrt{a^2 + b^2}.$$

10. What is the equation of the surface

$$x^2 + y^2 + 2z^2 - 2z(x + y) = a^2$$

when referred to new axes such that the new x -axis is equally inclined to OX , OY , and OZ , and the new y -axis is the line $x + y = 0, z = 0$? *Ans.* $y^2 + 3z^2 = a^2$.

11. Show that the six planes, each passing through one edge of a tetrahedron and bisecting the opposite edge, meet in a point.

12. Through the middle point of every edge of a tetrahedron a plane is drawn perpendicular to the opposite edge. Show that the six planes so drawn will meet in a point such that the centroid of the tetrahedron is midway between it and the centre of the circumscribed sphere.

13. Through two fixed straight lines in space two planes are drawn at right angles to one another. Find the locus of their line of intersection. (See § 147.)

14. A line of constant length has its extremities on two given straight lines. Find the equation of the surface generated by it, and show that any point on the line describes an ellipse.

15. A straight line meets two given straight lines and makes the same angle with both of them. Find the equation of the surface which it generates.

16. Three straight lines mutually at right angles meet in a point P , and two of them intersect the axes of x and y respectively, while the third passes through the fixed point $(0, 0, c)$. Show that the equation of the locus of P is

$$x^2 + y^2 + z^2 = 2cz.$$

17. Show that when the new axes are chosen, as in Ex. 10, the equation of the surface $xy + yz + zx = 0$ becomes $2x^2 - y^2 - z^2 = 0$.

CHAPTER XV

CONICOIDS

152. A surface whose equation is of the second degree is called a **Conicoid**. In this chapter we shall investigate some of the properties of the conicoids by taking the equations of these surfaces in their *Standard Forms*. We shall begin with the *Sphere*, which may be defined as the locus of a point whose distance from a fixed point is constant. From this definition it follows at once from equation (2), § 129, that, if the centre is at the origin and the radius is r , the equation of the sphere is

$$x^2 + y^2 + z^2 = r^2; \quad (1)$$

and if the centre is at the point (a, b, c) , the equation is

$$(x - a)^2 + (y - b)^2 + (z - c)^2 = r^2. \quad (2)$$

Moreover, the general equation

$$x^2 + y^2 + z^2 + 2Ax + 2By + 2Cz + D = 0, \quad (3)$$

may be written in the form

$$(x + A)^2 + (y + B)^2 + (z + C)^2 = A^2 + B^2 + C^2 - D, \quad (4)$$

which shows that the equation represents a sphere whose centre is the point $(-A, -B, -C)$ and whose radius is $\sqrt{A^2 + B^2 + C^2 - D}$. That is, every equation of the second degree in which the coefficients of x^2 , y^2 , and z^2 are equal, and in which the terms containing xy , yz , and zx do not appear, represents a sphere.

153. To find the equation of the tangent plane at any point (x', y', z') of the sphere.

Let the equation of the sphere be $x^2 + y^2 + z^2 = r^2$. (1)

The equations of the radius drawn to (x', y', z') are

$$\frac{x}{x'} = \frac{y}{y'} = \frac{z}{z'}. \quad (2)$$

Since the tangent plane passes through the point (x', y', z') and is perpendicular to this radius, its equation is

$$x'(x-x') + y'(y-y') + z'(z-z') = 0. \quad (3)$$

Since $x'^2 + y'^2 + z'^2 = r^2$, this equation reduces to

$$xx' + yy' + zz' = r^2. \quad (4)$$

In like manner, the equation of the plane tangent to the sphere—

$$x^2 + y^2 + z^2 + 2Ax + 2By + 2Cz + D = 0 \quad (5)$$

at the point (x', y', z') can be shown to be

$$xx' + yy' + zz' + A(x+x') + B(y+y') + C(z+z') + D = 0. \quad (6)$$

154. Interpretation of the expression

$$(x' - a)^2 + (y' - b)^2 + (z' - c)^2 - d^2 \quad (1)$$

when the point $P(x', y', z')$ is not on the sphere

$$(x - a)^2 + (y - b)^2 + (z - c)^2 - d^2 = 0. \quad (2)$$

Let l, m, n be the direction cosines of any line through P . Then the equations of this line may be written (§ 145)

$$\frac{x-x'}{l} = \frac{y-y'}{m} = \frac{z-z'}{n} = r. \quad (3)$$

Let this line intersect the sphere in the points Q and R . Then at the points Q and R [from (2) and (3)]

$$(lr + x' - a)^2 + (mr + y' - b)^2 + (nr + z' - c)^2 - d^2 = 0. \quad (4)$$

If r_1 and r_2 are the roots of this equation, we have

$$r_1 r_2 = (x' - a)^2 + (y' - b)^2 + (z' - c)^2 - d^2 = PQ \cdot PR. \quad (5)$$

That is, the expression (1), or (5), is always equal to the product of the distances from P to the sphere measured along any straight line passing through P .

If $r_1 r_2$ is *negative*, P is inside the sphere. Then (5) is the product of the segments of any chord passing through P ; it is also *numerically* equal to the square of the radius of the small circle on the sphere, whose centre is at P .

If $r_1 r_2$ is *positive*, P is outside the sphere. In this case the expression (5) is equal to the product of the whole secant by the external segment; and therefore it is also equal to *the square of any tangent PT drawn from P to the sphere.* (Cf. § 104.)

COR. All tangents drawn from an external point to a sphere are equal.

155. If a sphere passes through the line of intersection of two given spheres, tangents drawn from any point on it to the two given spheres are in a constant ratio.

$$\text{Let } S \equiv x^2 + y^2 + z^2 + 2Ax + 2By + 2Cz + D = 0, \quad (1)$$

$$\text{and } S' \equiv x^2 + y^2 + z^2 + 2A'x + 2B'y + 2C'z + D' = 0, \quad (2)$$

be the equations of two spheres, in each of which the coefficient of x^2 is unity. Then the equation of any sphere through their line of intersection is

$$S - \lambda S' = 0. \quad (3)$$

If PT , and PT' are tangents drawn from any point on (3) to (1) and (2) respectively, it follows from § 154 that

$$PT^2 = \lambda \cdot PT'^2, \quad (4)$$

which proves the proposition, since λ is constant for any particular sphere.

If $\lambda = 1$, equation (3) reduces to

$$2(A - A')x + 2(B - B')y + 2(C - C')z + D - D' = 0, \quad (5)$$

which is of the first degree, and therefore represents a *plane*.

The plane through the line of intersection of two spheres is called their **Radical Plane**. The radical plane of two spheres may also be defined as the locus of all points from which tangents drawn to the two spheres are equal.

EXAMPLES

1. What does the constant term D represent in the general equation of the sphere? Where is the origin if D is positive? if D is zero? if D is negative? Where is P in § 154 if $r_1 r_2 = -d^2$?

2. How many independent conditions can a sphere be made to satisfy?

3. Find the equation of a sphere through four given points.

Find the centres, radii, position of the origin, length of tangents from the origin, and the intercepts of the following spheres.

$$4. x^2 + y^2 + z^2 - 2x - 4y - 6z + 5 = 0.$$

$$5. x^2 + y^2 + z^2 + 10x - 24y = 0.$$

$$6. x^2 + y^2 + z^2 + 6x - 8y + 2z - 10 = 0.$$

$$7. x^2 + y^2 + z^2 - 4x + 6y + 10z = 0.$$

Find the equation of a sphere

8. With centre on one of the coordinate axes and passing through the origin.
9. Touching two of the coordinate planes.
10. Touching the three coordinate planes.
11. Touching two of the coordinate axes.
12. Touching the three coordinate axes.
13. Touching the three axes and passing through the point $(2, 4, 0)$.

How many such spheres are there ?

14. Show that if the coordinates of the extremities of a diameter of a sphere are (x_1, y_1, z_1) and (x_2, y_2, z_2) its equation may be written

$$(x - x_1)(x - x_2) + (y - y_1)(y - y_2) + (z - z_1)(z - z_2) = 0.$$

15. Show that the polar equation of the sphere

$$x^2 + y^2 + z^2 + 2Ax + 2By + 2Cz + D = 0$$

is

$$\rho^2 + 2\rho(Al + Bm + Cn) + D = 0.$$

What property of the sphere follows from the fact that the product of the roots of this last equation is constant ?

16. Show that the radical plane of two spheres is perpendicular to their line of centres, and bisects all their common tangents.

17. Show that the radical planes of three spheres meet in a line which is perpendicular to the plane through the centres of the spheres.

This line is called the **Radical Axis** of the three spheres.

18. Show that the radical planes of four spheres meet in a point.

This point is called the **Radical Centre** of the four spheres.

19. What is the geometric property of the radical axis of three spheres ? of the radical centre of four spheres ? What is the analytic condition that the origin shall be the radical centre of four spheres ?

20. A and B are two fixed points, and P a variable point such that $PA = n \cdot PB$. Show that the locus of P is a sphere. Show also that all such spheres, for different values of n , have a common radical plane.

21. Show that the spheres whose equations are

$$x^2 + y^2 + z^2 + 2Ax + 2By + 2Cz + D = 0$$

and

$$x^2 + y^2 + z^2 + 2A'x + 2B'y + 2C'z + D' = 0$$

will cut one another at right angles if

$$2AA' + 2BB' + 2CC' - D - D' = 0.$$

THE CONE

156. To find the equation of a cone generated by a straight line passing through the origin, of which the guiding curve is a conic.

Let the equations of the guiding conic be

$$\frac{x^2}{a^2} + \frac{y^2}{b^2} = 1, \quad z = c. \quad (1)$$

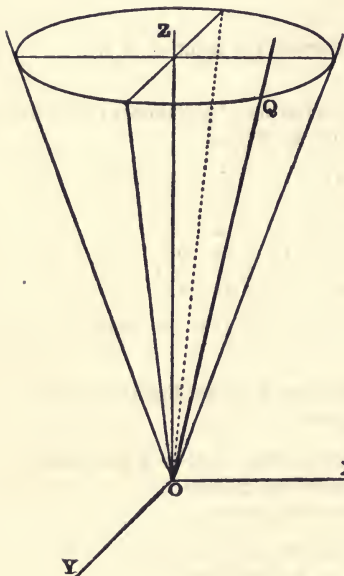

Let $Q(x_1, y_1, c)$ be any point on the guiding conic; then

$$\frac{x_1^2}{a^2} + \frac{y_1^2}{b^2} = 1, \quad (2)$$

and the equations of the generating line OQ are

$$\frac{x}{x_1} = \frac{y}{y_1} = \frac{z}{c} = r. \quad (3)$$

Whence

$$x_1 = \frac{x}{r}, \quad y_1 = \frac{y}{r}, \quad \text{and} \quad \frac{z}{cr} = 1. \quad (4)$$

Substituting these values in equation (2) gives

$$\frac{x^2}{a^2 r^2} + \frac{y^2}{b^2 r^2} = \frac{z^2}{c^2 r^2}. \quad (5)$$

$$\therefore \frac{x^2}{a^2} + \frac{y^2}{b^2} - \frac{z^2}{c^2} = 0, \quad (6)$$

which is the required equation.

By putting x , y , and z respectively equal to zero in (6), we find the equations of the traces of the cone to be

$$\frac{y^2}{b^2} - \frac{z^2}{c^2} = 0, \quad \frac{x^2}{a^2} - \frac{z^2}{c^2} = 0, \quad \frac{x^2}{a^2} + \frac{y^2}{b^2} = 0. \quad (7)$$

Each of the first two of these sections is a pair of straight lines through the origin, and the third is a point ellipse.

By putting x , y , and z respectively equal to k , we find the equations of the three sets of contours to be

$$\frac{z^2}{c^2} - \frac{y^2}{b^2} = \frac{k^2}{a^2}, \quad \frac{z^2}{c^2} - \frac{x^2}{a^2} = \frac{k^2}{b^2}, \quad \frac{x^2}{a^2} + \frac{y^2}{b^2} = \frac{k^2}{c^2}, \quad (8)$$

each of which for different values of k represents a system of similar and coaxial conics (§ 116). The first two are hyperbolas with transverse axes along the z -axis, and whose asymptotes are the traces on the corresponding coordinate planes. The last are ellipses which increase indefinitely in size as the cutting plane recedes from the origin. As a check it should be noticed that the section made by the plane $z = c$ is the guiding conic.

If we take as the guiding conic the hyperbola

$$\frac{y^2}{b^2} - \frac{x^2}{a^2} = 1, \quad z = c, \quad (9)$$

the equation of the surface will be

$$\frac{x^2}{a^2} - \frac{y^2}{b^2} + \frac{z^2}{c^2} = 0, \quad (10)$$

which is a cone extending along the y -axis, since the sections perpendicular to this axis are ellipses with centres on this axis.

Similarly, if the guiding conic is the hyperbola

$$\frac{x^2}{a^2} - \frac{y^2}{b^2} = 1, \quad z = c, \quad (11)$$

the resulting equation will be

$$-\frac{x^2}{a^2} + \frac{y^2}{b^2} + \frac{z^2}{c^2} = 0, \quad (12)$$

which represents a cone extending along the x -axis.

If we take as the guiding conic the parabola

$$y^2 = 4ax, \quad z = c, \quad (13)$$

the equation of the cone will be

$$cy^2 = 4axz. \quad (14)$$

The traces of this surface show that the cone is tangent to the coordinate planes $x=0$, $z=0$, along the z -axis, and x -axis respectively; *i.e.* these axes are elements of the cone. The xz -contours are the rectangular hyperbolas $4axz = ck^2$. The other two sets of contours are the parabolas

$$cy^2 = 4akz \quad \text{and} \quad cy^2 = 4akx. \quad (15)$$

Observe that these parabolas are sections made by planes parallel to an element of the cone.

If we transform equation (14) by turning the axes of x and z clockwise through an angle of 45° , the new equation will be

$$\frac{x^2}{c} + \frac{y^2}{2a} - \frac{z^2}{c} = 0, \quad (16)$$

which is of the same form as equation (6), and therefore represents a cone extending along the new z -axis. It follows from equations (6), (10), (12), and (16) that the conical surface generated is essentially the same, whatever the form of the guiding conic.

The equations of the cone found above are all homogeneous. Moreover, if they are referred to any new set of rectangular axes having the same origin [(1), § 151], the new equations will also be homogeneous. Furthermore, *any homogeneous equation represents a cone whose vertex is at the origin*. For if the coordinates of the point (x, y, z) satisfy a homogeneous equation, so also will the coordinates of the point (kx, ky, kz) , whatever the value of k may be. Hence a line through the origin and any point on the surface lies wholly on the surface.

157. Definitions.—The form of equations (6), (10), (12), and (16) of § 156 shows that the surfaces which they represent are symmetrical with respect to each of the coordinate planes, and also with respect to the origin. That is, each of these planes bisects all chords of the surface which are perpendicular to the plane. A plane which bisects all chords of a conicoid which are perpendicular to it, is called a **Principal Plane**. The sections made by the principal planes are called the **Principal Sections** of the conicoid. The lines of intersection of the principal planes are called the **Axes** of the conicoid; they are also the axes of the principal sections. The point of intersection of the principal planes is called the **Centre** of the conicoid.

It follows from these definitions that the cones in § 156 have three principal planes and three axes. These are the coordinate planes and the coordinate axes, with the single exception of the locus of equation (14). Moreover, we have also found in § 156 that if the guiding conic is an ellipse, a hyperbola, or a parabola, the cone is such that sections perpendicular to *one of its axes* are ellipses. Such a cone is called an *Elliptic Cone* to distinguish it from the cone of revolution, or circular cone.

THE ELLIPSOID

158. Let
$$\frac{x^2}{a^2} + \frac{z^2}{c^2} = 1, \quad y = 0; \quad (1)$$

and
$$\frac{x^2}{a^2} + \frac{y^2}{b^2} = 1, \quad z = 0, \quad (2)$$

be two fixed ellipses, XZ , XY , having a common major axis; and let ABC be a variable ellipse which moves so that its plane is

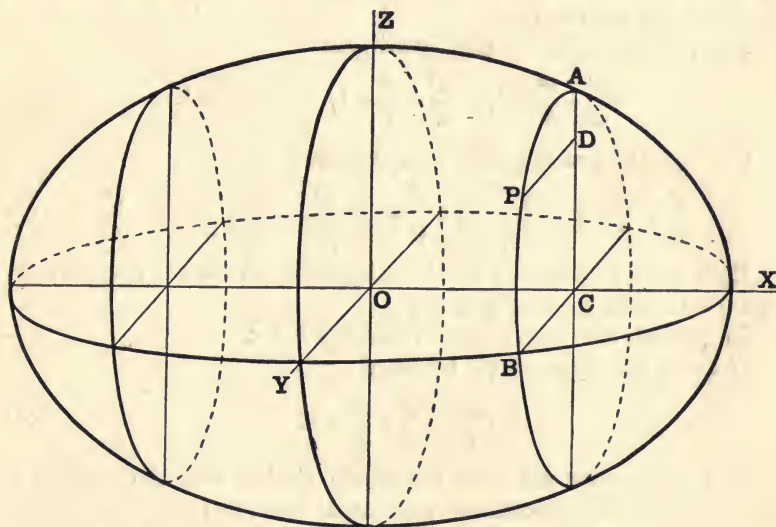

always parallel to the yz -plane, and which changes in size so that the ends of its axes, A and B , always lie in the two fixed ellipses. The surface generated by this variable ellipse is called an **Ellipsoid**.

Let $P(x, y, z)$ be any point in the ellipse AB , whose semi-axes are CA , CB ; and let PD be drawn perpendicular to CA . Then, since $DP = y$ and $CD = z$,

$$\frac{y^2}{CB^2} + \frac{z^2}{CA^2} = 1. \quad (3)$$

Since A and B are also on the two fixed ellipses (1) and (2), respectively, and their coordinates are $(x, 0, CA)$ and $(x, CB, 0)$, we have

$$\frac{x^2}{a^2} + \frac{CA^2}{c^2} = 1, \quad \text{and} \quad \frac{x^2}{a^2} + \frac{CB^2}{b^2} = 1. \quad (4)$$

Substituting in (3) the values of CA^2 and CB^2 given by equations (4), we get

$$\frac{x^2}{a^2} + \frac{y^2}{b^2} + \frac{z^2}{c^2} = 1, \quad (5)$$

which is the *standard equation* of the ellipsoid.

The surface is symmetrical with respect to each of the coordinate planes, and also with respect to the origin. Hence these are the principal planes of the surface, the coordinate axes are its axes, and the origin is the centre.

The principal sections are the ellipses

$$\frac{x^2}{a^2} + \frac{y^2}{b^2} = 1, \quad \frac{x^2}{a^2} + \frac{z^2}{c^2} = 1, \quad \frac{y^2}{b^2} + \frac{z^2}{c^2} = 1. \quad (6)$$

The equations of the three sets of contours are

$$\frac{y^2}{b^2} + \frac{z^2}{c^2} = 1 - \frac{k^2}{a^2}, \quad \frac{x^2}{a^2} + \frac{z^2}{c^2} = 1 - \frac{k^2}{b^2}, \quad \frac{x^2}{a^2} + \frac{y^2}{b^2} = 1 - \frac{k^2}{c^2}. \quad (7)$$

Each set is a system of similar ellipses which vanish, respectively, when k is equal to $\pm a$, $\pm b$, $\pm c$.

In general, it is here assumed that $a > b > c$.

If $c = b$, the equation (5) becomes

$$\frac{x^2}{a^2} + \frac{y^2}{b^2} + \frac{z^2}{b^2} = 1. \quad (8)$$

The yz -contours are now concentric circles, and the surface is an ellipsoid of revolution generated by revolving the ellipse $b^2x^2 + a^2y^2 = a^2b^2$ about its major axis. This surface is called a **Prolate Spheroid**.

If $b = a$, the equation of the surface (5) takes the form

$$\frac{x^2}{a^2} + \frac{y^2}{a^2} + \frac{z^2}{c^2} = 1, \quad (9)$$

of which the xy -contours are concentric circles. The surface is an ellipsoid of revolution generated by revolving the ellipse (1) about its minor axis, *i.e.* the z -axis. Such a surface is called an **Oblate Spheroid**.

If $c = b = a$, the ellipsoid becomes the sphere

$$x^2 + y^2 + z^2 = a^2. \quad (10)$$

THE HYPERBOLOID OF ONE SHEET

159. Let $\frac{x^2}{a^2} - \frac{z^2}{c^2} = 1, y = 0;$ (1)

and $\frac{y^2}{b^2} - \frac{z^2}{c^2} = 1, x = 0,$ (2)

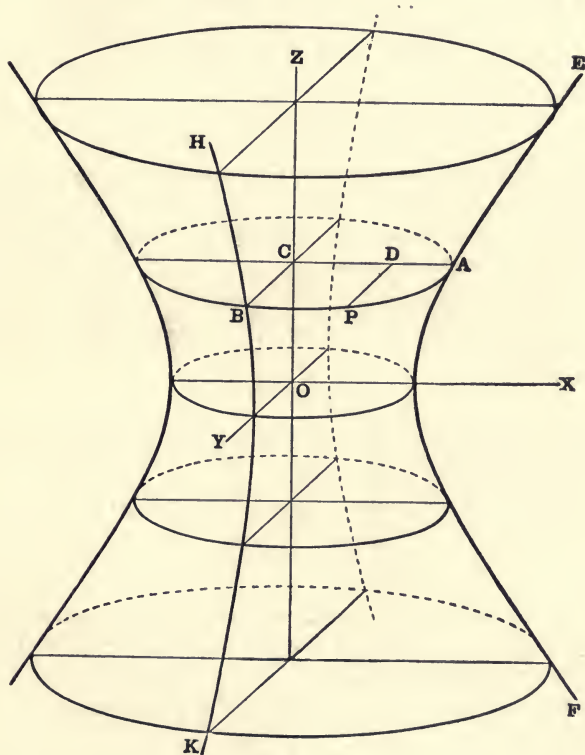

be two fixed hyperbolas, EF, HK , having a common conjugate axis OZ ; and let ABC be a variable ellipse which moves so that its plane is always parallel to the xy -plane, and which changes its size so that the ends of its axes, A and B , always lie in the two fixed hyperbolas. The surface generated by this variable ellipse is called a **Hyperboloid of One Sheet**.

Let $P(x, y, z)$ be any point in the ellipse AB , and let PD be drawn perpendicular to AC ; then, since $CD = x$, $DP = y$, and CA, CB are the semi-axes of the ellipse,

$$\frac{x^2}{CA^2} + \frac{y^2}{CB^2} = 1. \quad (3)$$

Since A and B are on the fixed hyperbolas (1) and (2),

$$\frac{CA^2}{a^2} - \frac{z^2}{c^2} = 1, \quad \frac{CB^2}{b^2} - \frac{z^2}{c^2} = 1. \quad (4)$$

$$\therefore \frac{x^2}{a^2} + \frac{y^2}{b^2} - \frac{z^2}{c^2} = 1, \quad (5)$$

which is the *standard equation* of the hyperboloid of one sheet.

The surface is symmetrical with respect to each of the coordinate planes, and also with respect to the origin. Hence the coordinate axes are the axes of the surface, and the origin is its centre.

The principal sections made by the planes $x = 0$ and $y = 0$ are the two fixed hyperbolas (2) and (1), and the section made by the plane $z = 0$ is the ellipse

$$\frac{x^2}{a^2} + \frac{y^2}{b^2} = 1. \quad (6)$$

The intercepts on the axes of x and y are $\pm a$ and $\pm b$, but the surface does not intersect the z -axis.

The equation of the xy -contours made by $z = k$ is

$$\frac{x^2}{a^2} + \frac{y^2}{b^2} = 1 + \frac{k^2}{c^2}. \quad (7)$$

These sections are similar coaxial ellipses for all values of k , which increase in size without limit as the cutting plane recedes in either direction from the origin.

The equation of the contours made by the plane $x = k$ is

$$\frac{y^2}{b^2} - \frac{z^2}{c^2} = 1 - \frac{k^2}{a^2}. \quad (8)$$

These sections are hyperbolas for all values of k . If $-a < k < a$ these hyperbolas have their transverse axes along the y -axis, but if $k > a$, or $k < -a$, their transverse axes lie along the z -axis. When $k = \pm a$, the contour is a pair of straight lines, which are the asymptotes of the entire system of hyperbolas.

Similarly, the contours made by $y = k$ are the hyperbolas

$$\frac{x^2}{a^2} - \frac{z^2}{c^2} = 1 - \frac{k^2}{b^2}, \quad (9)$$

which have their transverse axes along the x -axis, or z -axis, according as $k <$, or $> b$, numerically, and whose common asymptotes are the contours made by the planes $y = \pm b$.

When $b = a$, the equation (5) of the surface becomes

$$\frac{x^2}{a^2} + \frac{y^2}{a^2} - \frac{z^2}{c^2} = 1, \quad (10)$$

which is a hyperboloid of revolution generated by revolving the hyperbola (1) about its conjugate axis.

160. *Asymptotic cone of the hyperboloid of one sheet.*

Let the equation of the hyperboloid be

$$\frac{x^2}{a^2} + \frac{y^2}{b^2} - \frac{z^2}{c^2} = 1. \quad (1)$$

Let

$$\frac{x^2}{a^2} + \frac{y^2}{b^2} - \frac{z^2}{c^2} = 0, \quad (2)$$

be the equation of a cone along the z -axis [(6), § 156].

The equations of the contours of these two surfaces made by the plane $z = k$ are, respectively,

$$\frac{x^2}{a^2} + \frac{y^2}{b^2} = 1 + \frac{k^2}{c^2}, \quad (3)$$

and

$$\frac{x^2}{a^2} + \frac{y^2}{b^2} = \frac{k^2}{c^2}. \quad (4)$$

A comparison of equations (3) and (4) shows that, for the same finite value of k , the section of the cone is smaller than the section of the hyperboloid. Hence the cone may be said to lie inside of the hyperboloid.

Equation (3) may also be written in the form

$$\frac{x^2}{a^2} + \frac{y^2}{b^2} = \frac{k^2}{c^2} \left(1 + \frac{c^2}{k^2} \right)_{k \rightarrow \infty} = \frac{k^2}{c^2}, \quad (5)$$

which shows that the sections of the two surfaces become equal, *i.e.* they approach the same limit, when the cutting plane recedes in either direction to an infinite distance from the origin. That is, the

cone is tangent to the hyperboloid at infinity, and is, therefore, called the **Asymptotic Cone** of the hyperboloid of one sheet.

THE HYPERBOLOID OF TWO SHEETS

161. Let
$$\frac{x^2}{a^2} - \frac{z^2}{c^2} = 1, y = 0; \quad (1)$$

and
$$\frac{x^2}{a^2} - \frac{y^2}{b^2} = 1, z = 0, \quad (2)$$

be two fixed hyperbolas, EF , EH , having a common transverse axis; and let ABC be a variable ellipse which moves so that its

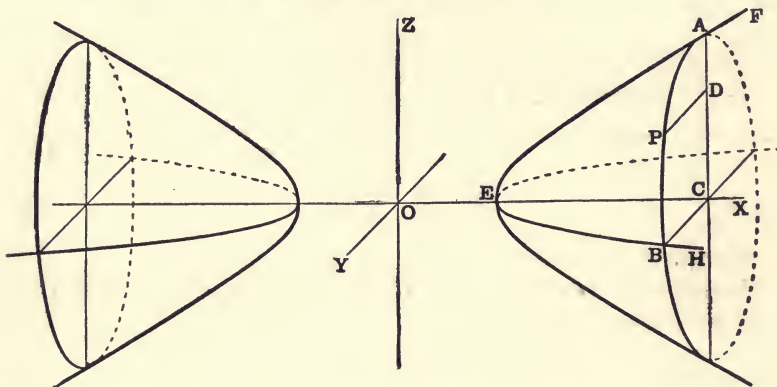

plane is always parallel to the yz -plane, and which changes its size so that the ends of its axes, A and B , always lie in the two fixed hyperbolas. The surface generated by this variable ellipse is called a **Hyperboloid of Two Sheets**.

Let $P(x, y, z)$ be any point on the ellipse AB , and let PD be drawn perpendicular to CA ; then, since $CD = z$, $DP = y$, and CA , CB are the semi-axes of the ellipse,

$$\frac{y^2}{CB^2} + \frac{z^2}{CA^2} = 1. \quad (3)$$

Since A and B are also on the fixed hyperbolas (1) and (2),

$$\frac{x^2}{a^2} - \frac{CA^2}{c^2} = 1, \text{ and } \frac{x^2}{a^2} - \frac{CB^2}{b^2} = 1. \quad (4)$$

$$\therefore \frac{x^2}{a^2} - \frac{y^2}{b^2} - \frac{z^2}{c^2} = 1, \quad (5)$$

which is the *standard equation* of the hyperboloid of two sheets.

The surface is symmetrical with respect to each of the coordinate planes and the origin. Hence the axes of coordinates are the axes, and the origin is the centre of the surface.

The intercepts on the x -axis are $\pm a$, but the surface does not intersect either of the other axes.

The equation of the contours made by the plane $x = k$ is

$$\frac{y^2}{b^2} + \frac{z^2}{c^2} = \frac{k^2}{a^2} - 1. \quad (6)$$

These sections are imaginary for all values of k between $+a$ and $-a$. Hence there are no real points on the surface between the planes $x = a$ and $x = -a$. If k is numerically greater than a , these sections are real ellipses which increase indefinitely in size as k increases without limit, but reduce to points when $k = \pm a$. Hence the planes $x = \pm a$ are tangent to the surface. Thus the surface is shown to consist of two distinct parts, and for this reason the hyperboloid is said to have *two sheets*.

The xy and xz -contours are hyperbolas with transverse axes along the x -axis, and whose asymptotes are the traces of the asymptotic cone on the xy and xz -planes. From § 160 it is evident that the equation of the asymptotic cone is

$$\frac{x^2}{a^2} - \frac{y^2}{b^2} - \frac{z^2}{c^2} = 0. \quad (7)$$

If $c = b$, equation (5) becomes

$$\frac{x^2}{a^2} - \frac{y^2}{b^2} - \frac{z^2}{b^2} = 1, \quad (8)$$

which is the equation of a two-sheeted hyperboloid of revolution generated by revolving the hyperbola (2) about its transverse axes.

Two conicoids are similar if their principal sections are similar conics. Hence, if K is an arbitrary parameter, the equations,

$$\frac{x^2}{a^2} \pm \frac{y^2}{b^2} \pm \frac{z^2}{c^2} = K, \quad (9)$$

represent systems of similar conicoids (§ 116).

THE ELLIPTIC PARABOLOID

162. Let ABC be a variable ellipse whose plane is always parallel to the xy -plane, and whose vertices A, B move along the two fixed parabolas OA and OB , whose equations are

$$x^2 = 2az, \quad y = 0; \quad (1)$$

and

$$y^2 = 2bz, \quad x = 0. \quad (2)$$

The surface generated by this moving ellipse is called the **Elliptic Paraboloid**.

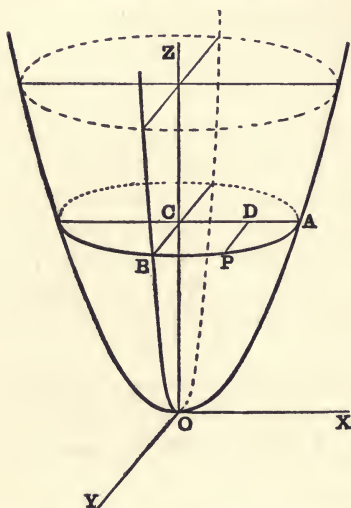

Let $P(x, y, z)$ be any point in the ellipse AB , and let PD be perpendicular to AC ; then since $CD = x$, and $DP = y$

$$\frac{x^2}{CA^2} + \frac{y^2}{CB^2} = 1. \quad (3)$$

Since A and B are also on the parabolas (1) and (2), respectively, and $OC = z$

$$CA^2 = 2az,$$

and

$$CB^2 = 2bz. \quad (4)$$

$$\therefore \frac{x^2}{a} + \frac{y^2}{b} = 2z, \quad (5)$$

which is the *standard equation* of the elliptic paraboloid.

The surface is symmetrical with respect to the xz and yz planes, and the z -axis. Hence the z -axis is called the axis of the paraboloid. The surface passes through the origin, cutting the z -axis once, the x and y axes each twice, but does not cut the axes at any other point.

If we put $z = k$ in (5), we get

$$\frac{x^2}{a} + \frac{y^2}{b} = 2k. \quad (6)$$

Hence a section parallel to the xy -plane is imaginary if k is negative. If k is positive, the section is an ellipse which increases in size as the plane recedes from the origin, and diminishes to a point when $k = 0$. Therefore the surface is tangent to the xy -plane, and lies wholly above this plane.

The equations of the xz and yz -contours are

$$x^2 = 2az - \frac{ak^2}{b}, \text{ and } y^2 = 2bz - \frac{bk^2}{a}. \quad (7)$$

From equations (1) and (2) we see that, for all values of k , these sections are respectively equal to the two fixed parabolas OA and OB .

If $b = a$, equation (5) may be written

$$x^2 + y^2 = 2az, \quad (8)$$

which represents a paraboloid of revolution about the z -axis.

THE HYPERBOLIC PARABOLOID

163. Let $x^2 = 2az, y = 0,$ (1)

be the equations of a fixed parabola OA , and let AE be another given parabola with a constant latus rectum $2b$. Let the parabola AE move, keeping its vertex A in the fixed parabola OA , its plane parallel to the yz -plane, and its axis AR in the xz -plane, the concavities of the two parabolas being turned in opposite directions. The surface generated by this moving parabola AE is called a **Hyperbolic Paraboloid**.

Let $P(x, y, z)$ be any point on the parabola AE . Draw PD perpendicular to AR ; DC and AB perpendicular to OZ .

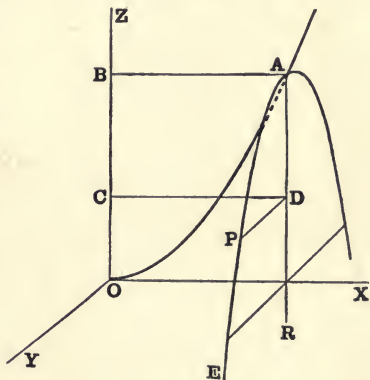

Then $BA^2 \equiv x^2 = 2a \cdot OB$, and $DP^2 \equiv y^2 = 2b \cdot DA$. (2)

Whence $\frac{x^2}{2a} - \frac{y^2}{2b} = OB - DA = OC \equiv z$. (3)

$$\therefore \frac{x^2}{a} - \frac{y^2}{b} = 2z, \quad (4)$$

which is the *standard equation* of the hyperbolic paraboloid.

The surface is symmetrical with respect to the planes $x = 0$ and $y = 0$, and the z -axis. Hence the z -axis is called the axis of the surface. The surface cuts the z -axis in one point, the x and y axes each in two coincident points at the origin.

If we put $z = k$ in equation (4) we get

$$\frac{x^2}{a} - \frac{y^2}{b} = 2k, \quad (5)$$

which represents a hyperbola with transverse axis on the x -axis or y -axis according as k is *positive* or *negative*. When $k = 0$, the section is two straight lines, HK and LM (large figure), which are the asymptotes of all these contours.

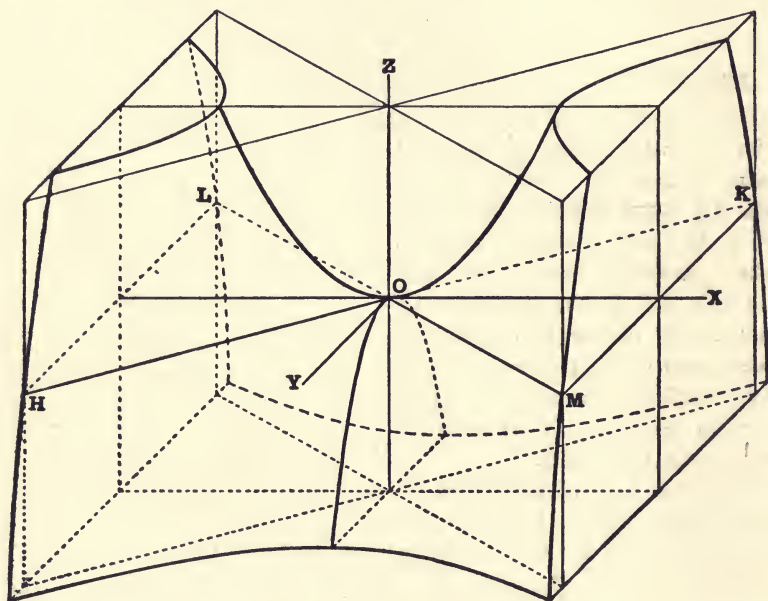

The equations of the xz and yz -contours are

$$x^2 = 2az + \frac{ak^2}{b}, \text{ and } y^2 = -2bz + \frac{bk^2}{a}, \quad (6)$$

which for all possible values of k represent two systems of parabolas. The first are all equal to the fixed parabola OA with axes turned upward, the second are all equal to the movable parabola AE with axes turned downward.

164. *The paraboloids are the limiting forms of the central conicoids as the centre recedes to infinity.*

Let the equations of the central conicoids be

$$\frac{x^2}{a^2} \pm \frac{y^2}{b^2} \pm \frac{z^2}{c^2} = 1. \quad (1)$$

If the origin is moved to the point $(-a, 0, 0)$, the new equation may be written

$$\frac{x^2}{a} \pm \frac{ay^2}{b^2} \pm \frac{az^2}{c^2} = 2x. \quad (2)$$

Let $\frac{b^2}{a} \equiv l$, and $\frac{c^2}{a} \equiv l'$; then l, l' are respectively the semi-latera recta of the principal sections made by the planes $z=0$, and $y=0$.

Equation (2) may then be written

$$\frac{x^2}{a} \pm \frac{y^2}{l} \pm \frac{z^2}{l'} = 2x. \quad (3)$$

Now, if a becomes infinite, while l and l' remain finite, equation (3) becomes in the limit, for the ellipsoid, hyperboloid of two sheets, and one sheet, respectively,

$$\frac{y^2}{l} + \frac{z^2}{l'} = 2x, \quad \frac{y^2}{l} + \frac{z^2}{l'} = -2x, \quad \frac{y^2}{l} - \frac{z^2}{l'} = 2x. \quad (4)$$

The first two are elliptic paraboloids, the last is a hyperbolic paraboloid, all with axes coinciding with the x -axis.

EXAMPLES

1. Show that a hyperboloid degenerates into a cone when its axes become indefinitely small, preserving a finite ratio to each other.
2. Show that the traces of the asymptotic cone are the asymptotes of the contours of the hyperboloids.
3. Compare the section of the hyperboloid of one sheet [(5), § 159] made by the plane $x = k$ with the section of its asymptotic cone made by the plane $x = \sqrt{k^2 - a^2}$. What does this show?
4. Show how an elliptic paraboloid may be generated by a moving parabola.
5. Show how a hyperbolic paraboloid may be generated by a moving hyperbola.
6. Show that all planes parallel to the axis of a paraboloid cut the surface in parabolas.
7. Show that the projections, on a plane perpendicular to the axis of a paraboloid, of all plane sections not parallel to the axis, are similar conics.

8. Show that all parallel parabolic sections of a paraboloid are equal.

9. Let r_1, r_2, r_3 be any three semi-diameters of an ellipsoid which are mutually at right angles. Show that

$$\frac{1}{r_1^2} + \frac{1}{r_2^2} + \frac{1}{r_3^2} = \frac{1}{a^2} + \frac{1}{b^2} + \frac{1}{c^2}.$$

10. Show that the equation of the cone whose vertex is at the origin and which passes through all the points of intersection of the ellipsoid [(5), § 158] and the plane $lx + my + nz = 1$ is

$$\frac{x^2}{a^2} + \frac{y^2}{b^2} + \frac{z^2}{c^2} = (lx + my + nz)^2.$$

11. Show that the two conjugate hyperboloids

$$\frac{x^2}{a^2} + \frac{y^2}{b^2} - \frac{z^2}{c^2} = \pm 1,$$

have a common asymptotic cone, and show how they are situated with respect to this cone.

12. What are the limiting forms of the asymptotic cones as the hyperboloids pass into paraboloids in § 164?

TANGENT PLANES

165. To find the equation of the tangent plane at any point (x', y', z') on a conicoid.

Let the equation of the conicoid be

$$\frac{x^2}{a^2} + \frac{y^2}{b^2} + \frac{z^2}{c^2} = 1. \quad (1)$$

Let the equations of any line through the point (x', y', z') be

$$\frac{x - x'}{l} = \frac{y - y'}{m} = \frac{z - z'}{n} = r, \quad (\S 145) \quad (2)$$

or $x = x' + lr, \quad y = y' + mr, \quad z = z' + nr. \quad (3)$

The distances from the point (x', y', z') to the points where this line meets the conicoid are the values of r given by the equation

$$\frac{(x' + lr)^2}{a^2} + \frac{(y' + mr)^2}{b^2} + \frac{(z' + nr)^2}{c^2} = 1, \quad (4)$$

or $r^2 \left(\frac{l^2}{a^2} + \frac{m^2}{b^2} + \frac{n^2}{c^2} \right) + 2r \left(\frac{lx'}{a^2} + \frac{my'}{b^2} + \frac{nz'}{c^2} \right) + \frac{x'^2}{a^2} + \frac{y'^2}{b^2} + \frac{z'^2}{c^2} - 1 = 0. \quad (5)$

Since the point (x', y', z') is on the conicoid,

$$\frac{x'^2}{a^2} + \frac{y'^2}{b^2} + \frac{z'^2}{c^2} - 1 = 0. \quad (6)$$

Therefore one value of r is zero, whatever the direction of the line (2) may be. But if we choose the direction of the line so that we also have

$$\frac{lx'}{a^2} + \frac{my'}{b^2} + \frac{nz'}{c^2} = 0, \quad (7)$$

the other value of r will also vanish; that is, the line will then meet the surface in two coincident points, and is therefore a tangent line at the point (x', y', z') .

The equation of the locus of all the tangent lines which can be drawn through the point (x', y', z') is found by eliminating l, m, n between equations (2) and (7). We thus obtain

$$\frac{x'}{a^2}(x - x') + \frac{y'}{b^2}(y - y') + \frac{z'}{c^2}(z - z') = 0, \quad (8)$$

which, by virtue of equation (6), reduces to

$$\frac{xx'}{a^2} + \frac{yy'}{b^2} + \frac{zz'}{c^2} = 1. \quad (9)$$

Hence the tangent lines all lie in a plane. This plane is called the **Tangent Plane** at the point (x', y', z') .

By a proper choice of signs in (9) we can write the equation of the tangent plane to either of the hyperboloids.

It should be noticed that the factors before the parentheses in equation (8) can be obtained by taking half the *partial derivatives* (§ 61) of equation (1) with respect to x, y, z , respectively, and then substituting in these derivatives x' for x, y' for y , and z' for z . It can be shown that this rule holds for any surface.

Assuming this rule to hold for the paraboloids

$$\frac{x^2}{a} \pm \frac{y^2}{b} - 2z = 0, \quad (10)$$

we have for the tangent plane at the point (x', y', z')

$$\frac{x'}{a}(x - x') \pm \frac{y'}{b}(y - y') - (z - z') = 0, \quad (11)$$

or
$$\frac{xx'}{a} \pm \frac{yy'}{b} = (z + z'). \quad (12)$$

This should also be proved independently.

Ex. Show by means of equation (5) that every plane section of a conicoid is a conic.

166. The **Normal** to a surface at any point P is the straight line through P perpendicular to the tangent plane at P .

Hence the equations of the normal to the ellipsoid at the point (x', y', z') are [(9), § 165]

$$\frac{x - x'}{\frac{x'}{a^2}} = \frac{y - y'}{\frac{y'}{b^2}} = \frac{z - z'}{\frac{z'}{c^2}}, \quad (1)$$

and to the elliptic paraboloid [(11), § 165]

$$\frac{x - x'}{a} = \frac{y - y'}{b} = \frac{z - z'}{-1}. \quad (2)$$

From these, by a proper choice of signs in the denominators, we easily obtain the normals to the other conicoids.

167. To find the condition that the plane

$$lx + my + nz = p \quad (1)$$

shall touch the ellipsoid.

The equation of the tangent plane at any point (x', y', z') of an ellipsoid is [(9), § 165]

$$\frac{xx'}{a^2} + \frac{yy'}{b^2} + \frac{zz'}{c^2} = 1. \quad (2)$$

Equations (1) and (2) will represent the same plane if

$$\frac{lx}{p} + \frac{my}{p} + \frac{nz}{p} - 1 \equiv \frac{xx'}{a^2} + \frac{yy'}{b^2} + \frac{zz'}{c^2} - 1. \quad (3)$$

Equating the coefficients of the identity (3) gives

$$\frac{l}{p} = \frac{x'}{a^2}, \quad \frac{m}{p} = \frac{y'}{b^2}, \quad \frac{n}{p} = \frac{z'}{c^2}. \quad (4)$$

Whence
$$\frac{a^2l^2 + b^2m^2 + c^2n^2}{p^2} = \frac{x'^2}{a^2} + \frac{y'^2}{b^2} + \frac{z'^2}{c^2} = 1. \quad (5)$$

Therefore the plane $lx + my + nz = p$ will touch the ellipsoid if

$$a^2l^2 + b^2m^2 + c^2n^2 = p^2. \quad (6)$$

In like manner it can be shown that the same plane (1) will touch the paraboloid

$$\frac{x^2}{a} + \frac{y^2}{b} = 2z \quad (7)$$

if

$$al^2 + bm^2 + 2pn = 0. \quad (8)$$

168. To find the locus of the point of intersection of three tangent planes to an ellipsoid which are mutually at right angles.

Let the equations of the three tangent planes be [(6), § 167]

$$l_1x + m_1y + n_1z = \sqrt{a^2l_1^2 + b^2m_1^2 + c^2n_1^2}, \quad (1)$$

$$l_2x + m_2y + n_2z = \sqrt{a^2l_2^2 + b^2m_2^2 + c^2n_2^2}, \quad (2)$$

and

$$l_3x + m_3y + n_3z = \sqrt{a^2l_3^2 + b^2m_3^2 + c^2n_3^2}. \quad (3)$$

Squaring and adding these equations we get, by virtue of the relations between the direction cosines of mutually perpendicular lines (§ 151),

$$x^2 + y^2 + z^2 = a^2 + b^2 + c^2. \quad (4)$$

Therefore the required locus is a sphere. This sphere is called the **Director Sphere** of the ellipsoid.

POLES AND POLAR PLANES

169. The equation of the plane tangent to the conicoid

$$\frac{x^2}{a^2} + \frac{y^2}{b^2} + \frac{z^2}{c^2} = 1 \quad (1)$$

at the point (x', y', z') , if this point is on the surface, is (§ 165)

$$\frac{xx'}{a^2} + \frac{yy'}{b^2} + \frac{zz'}{c^2} = 1. \quad (2)$$

Suppose, however, that the point (x', y', z') is not on the surface. What, then, is the meaning of this equation (2)? It still represents a real plane, which is related in some definite way to the point (x', y', z') and to the conicoid, since its parameters involve both the coordinates of the point and the parameters of the conicoid. In order to determine what this relation is, we will let

$$x = x' + lr, \quad y = y' + mr, \quad z = z' + nr \quad [(3), § 165] \quad (3)$$

be the equations of any straight line through the point (x', y', z') . Substituting these values of x, y, z in equation (2), we find the distance from the point (x', y', z') to the point where this line meets the plane (2) to be the value of r given by the equation

$$\frac{1}{r} = - \frac{\frac{lx'}{a^2} + \frac{my'}{b^2} + \frac{nz'}{c^2}}{\frac{x'^2}{a^2} + \frac{y'^2}{b^2} + \frac{z'^2}{c^2} - 1} \quad (4)$$

Let r_1 and r_2 be the distances from the point (x', y', z') to the points where this line (3) meets the conicoid (1). Then from equation (5), § 165, we get

$$\frac{1}{r_1} + \frac{1}{r_2} = -2 \frac{\frac{lx'}{a^2} + \frac{my'}{b^2} + \frac{nz'}{c^2}}{\frac{x'^2}{a^2} + \frac{y'^2}{b^2} + \frac{z'^2}{c^2} - 1}. \quad (5)$$

$$\therefore \frac{2}{r} = \frac{1}{r_1} + \frac{1}{r_2}, \text{ or } r = \frac{2 r_1 r_2}{r_1 + r_2}. \quad (6)$$

That is, *the plane (2) and the point (x', y', z') divide harmonically every chord of the conicoid (1) drawn through the point (x', y', z') .*

This plane is called the **Polar Plane** of the point (x', y', z') , and the point (x', y', z') is called the **Pole** of the plane with respect to the conicoid. (Cf. § 94.)

If $r_1 = r_2$, the line (3) is tangent to the surface. But when $r_1 = r_2$, we find from equation (6) that $r = r_1 = r_2$.

Therefore *the polar plane passes through the points of contact of all tangent lines drawn from its pole to the surface.*

The assemblage of such tangent lines forms a cone, which is called the **Tangent Cone** from the point to the surface.

Moreover, if $r_1 = 0$ and $r_2 \neq 0$, then $r = 0$ also, in whatever direction the line is drawn; *i.e.* if the point (x', y', z') is on the conicoid, it is also on its own polar plane. If $r_1 = r_2 = 0$, then r is indeterminate; *i.e.* when the line is tangent to the conicoid it lies wholly in the plane.

Therefore *the pole of a tangent plane is the point of contact.*

When the point (x', y', z') coincides with the centre of the conicoid, $r_1 = -r_2$, and therefore $r = \infty$.

Hence the polar plane of the centre is at infinity.

Furthermore, the second of equations (6) shows that r is always *real*, although r_1 and r_2 may be imaginary. This is evidently necessary, since the line will always meet the plane in one real point.

In a similar manner it can be shown that equation (12), § 165, is the polar plane of the point (x', y', z') with respect to the paraboloids.

170. *If the polar plane of a point P , with respect to a conicoid, passes through a point Q , then will the polar plane of Q pass through P .*

The proof of this proposition is precisely the same as that of the corresponding proposition in Plane Geometry (§ 95).

Let R and S be any two points on the line of intersection of two planes A and B , whose poles with respect to the same conicoid are P and Q . Then, since R is on both of the planes A and B , the polar plane of R will pass through both P and Q , and therefore through the line PQ . For the same reason the polar plane of S will pass through the line PQ . Similarly, the polar plane of any point P_1 on the line PQ will pass through the line RS .

The two lines PQ and RS which are such that the polar plane, with respect to a conicoid of any point on the one, passes through the other, are called **Polar**, or **Conjugate Lines**.

EXAMPLES ON CHAPTER XV

1. Show that every tangent plane to a cone, and the polar plane of any point (except the vertex) with respect to a cone, passes through the vertex.

2. Show that all normals to a sphere pass through its centre.

3. Show that the line OP joining the centre O of a sphere to a point P is perpendicular to the polar plane of P . If the line OP meets the polar plane in Q , show that $OP \cdot OQ = r^2$.

4. Show that the distances of two points from the centre of a sphere are proportional to the distances of each from the polar plane of the other.

5. Show that the locus of the point of intersection of three mutually perpendicular tangent planes to a paraboloid is a plane.

6. Find the equation of the director sphere of the surface generated by revolving a rectangular hyperbola around its conjugate axis.

7. Show that tangent planes at the ends of a diameter of a conicoid are parallel.

8. Prove that the locus of the poles of a series of parallel planes is a straight line through the centre of the conicoid.

9. Find the equation of a sphere which cuts four given spheres orthogonally. [See Ex. 21, p. 223.]

10. Show that a sphere which cuts each of the two spheres $S = 0$ and $S' = 0$ at right angles, will also cut the sphere $S + \lambda S' = 0$ at right angles.

11. Find the equation of the sphere which touches the plane $y = 0$, and cuts the plane $z = 0$ in the circle $(x - a)^2 + (y - b)^2 = r^2$. Show that the area of the section of the sphere made by the plane $x = 0$ is $\pi(b^2 - a^2)$. Why is this result independent of r ?

12. A straight line is drawn through a fixed point O , meeting a fixed plane in Q , and in this line a point P is taken such that $OP \cdot OQ$ is constant. Show that the locus of P is a sphere passing through O , whose centre is on the line through O perpendicular to the plane.

13. A straight line moves so that three fixed points, A, B, C , on the line lie one in each coordinate plane. Show that any other point P on the line generates an ellipsoid whose semi-axes are equal to PA, PB , and PC .

14. Show that the equation of the cone whose vertex is at the centre of the ellipsoid, and which goes through all points common to the ellipsoid and the sphere $x^2 + y^2 + z^2 = r^2$, is

$$x^2 \left(\frac{1}{a^2} - \frac{1}{r^2} \right) + y^2 \left(\frac{1}{b^2} - \frac{1}{r^2} \right) + z^2 \left(\frac{1}{c^2} - \frac{1}{r^2} \right) = 0.$$

15. If $a > b > c$ and $r = b$ in Ex. 14, show that the cone breaks up into two planes, whose intersections with the ellipsoid are circles.

16. If P and Q are any two points on an ellipsoid, the plane through the centre and the line of intersection of the tangent planes at P and Q will bisect the chord PQ .

17. P and Q are any two points on an ellipsoid, and planes through the centre parallel to the tangent planes at P and Q cut the chord PQ in P' and Q' . Show that $PP' = QQ'$.

18. The normal at any point P of an ellipsoid meets a principal plane in G . Show that the locus of the middle point of PG is an ellipsoid.

19. The normal at any point P of an ellipsoid meets the principal planes in G_1, G_2, G_3 . Show that PG_1, PG_2, PG_3 are in a constant ratio.

20. The normals to an ellipsoid at the points P, P' meet a principal plane in G, G' . Show that the plane which bisects PP' at right angles bisects GG' .

21. Show that a section of a hyperboloid made by a plane parallel to an element of the asymptotic cone is a parabola.

22. Show that the general equation of a cone referred to three of its generators as axes of coordinates is $fyz + gzx + hxy = 0$.

APPENDIX

I. *The Direction of a Curve at the Origin.*

It is often useful to know how to find the direction of a curve at the origin before taking up the formal study of *slope*. In many instances this can easily be done.

For example, let the equation of the curve be

$$y = x^2. \quad (1)$$

Let $P(x, y)$ be any point on the curve close to the origin. Draw the line OP , and let θ represent the angle XOP .

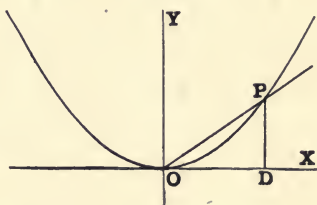

Then
$$\tan \theta = \frac{DP}{OD} = \frac{y}{x} \quad (2)$$

Since the point P is on the curve, we have, from equation (1),

$$\tan \theta = \frac{y}{x} = x. \quad (3)$$

The direction of the curve at the origin is the limiting direction of the line OP as we make the point P move along the curve and approach as near as we please to the origin. From equation (3) we get for this limiting direction of OP

$$\lim_{x \rightarrow 0} \tan \theta = \lim_{x \rightarrow 0} (x) = 0. \quad (4)$$

That is, the direction of the curve at the origin is the same as the direction of the x -axis.

If the equation of the given curve is

$$y = x^3 - x, \text{ or } \frac{y}{x} = x^2 - 1, \quad (5)$$

then
$$\lim_{x \rightarrow 0} \tan \theta = \lim_{x \rightarrow 0} (x^2 - 1) = -1. \quad (6)$$

Hence the direction of the curve at the origin is that of the line $y = -x$. (See the curve PQ in § 27.)

The direction of the curve at the origin can be found in this way whenever the equation of the curve can be put in the form

$$\frac{y}{x} = \phi(x), \quad (7)$$

provided we can find the limiting value of $\phi(x)$ as $x \doteq 0$.

Moreover, the direction of a curve at the points where it crosses the axes can be found in a similar manner. For example, the locus of equation (5) cuts the x -axis at the point $(1, 0)$. Let this point be R , and let $P(x, y)$ be a point on the curve close to R such that $x > 1$. Let θ be the angle RRP .

$$\text{Then} \quad \tan \theta = \frac{y}{x-1} = x^2 + x. \quad (8)$$

$$\therefore \lim_{x \doteq 1} \tan \theta = \lim_{x \doteq 1} (x^2 + x) = 2. \quad (9)$$

Hence the curve has the direction of the line $y = 2(x - 1)$.

EXAMPLES

Find the direction of the following curves at the origin :

- | | | |
|-----------------|-----------------------------|--|
| 1. $y = x^3$. | 2. $y = x^n$. | 3. $y^2 = x^3$. |
| 4. $y^2 = ax$. | 5. $x^3 - y^2(a - x) = 0$. | 6. $x(x^2 + y^2) - a(x^2 - y^2) = 0$. |

Find the direction of the following curves at the points where they cut the axes :

- | | |
|---|-----------------------------------|
| 7. $y = x^3 - 3x^2 + 2x$. (See Ex. 2, § 81.) | 8. $y = x^4 - x^2$. |
| 9. $y = x^3 - x^2 - 6x$. | 10. $y = x^3 - 2x^2 - 11x + 12$. |

II. *Example illustrating § 81.*

$$\text{Let} \quad f'(x) = 2kx. \quad (1)$$

$$\text{Then} \quad f(x) = kx^2 + c, \quad (2)$$

where c is an arbitrary constant which will disappear when we take the derivative.

Then

$$y = 2kx \equiv f'(x) \tag{3}$$

is the equation of the straight line $L'M'$, and

$$y = kx^2 + c \equiv f(x) \tag{4}$$

is the equation of the parabola LGM , where $OG = c$.

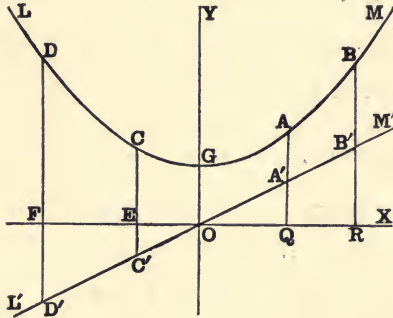

Let $OQ = a$ and $OR = b$. Then $QA' = 2ka$, $RB' = 2kb$, the area of the triangle $OQA' = ka^2$, and the area of triangle $ORB' = kb^2$.

$$\therefore \text{area of } QRB'A' = kb^2 - ka^2. \tag{5}$$

Also, $RB = f(b) = kb^2 + c$, and $QA = f(a) = ka^2 + c$ [from (4)]. $\tag{6}$

$$\therefore RB - QA = f(b) - f(a) = kb^2 - ka^2. \tag{7}$$

$$\therefore \text{area of } QRB'A' = f(b) - f(a) = RB - QA. \tag{8}$$

That is, *the number of square units in the area of the trapezoid is equal to the number of linear units in $(RB - QA)$.*

Similarly, the area of $EFD'C' = EC - FD$, a negative number.

If we put $c = 0$, the parabola will pass through the origin, and the ordinate QA will be zero when the area of the triangle OQA' is zero. Then the number of units in the ordinate QA will be equal to the number of units in the area of the triangle OQA' .

III. *Trigonometrical formulæ.*

1. $\sin \theta \csc \theta = 1.$
2. $\cos \theta \sec \theta = 1.$
3. $\tan \theta \cot \theta = 1.$
4. $\tan \theta = \frac{\sin \theta}{\cos \theta}.$
5. $\sin^2 \theta + \cos^2 \theta = 1.$
6. $\sec^2 \theta - \tan^2 \theta = 1.$
7. $\csc^2 \theta - \cot^2 \theta = 1.$
15. $\cos (270^\circ \pm \theta) = \pm \sin \theta.$
16. $\sin (\theta \pm \theta') = \sin \theta \cos \theta' \pm \cos \theta \sin \theta'.$
17. $\cos (\theta \pm \theta') = \cos \theta \cos \theta' \mp \sin \theta \sin \theta'.$
18. $\tan (\theta \pm \theta') = \frac{\tan \theta \pm \tan \theta'}{1 \mp \tan \theta \tan \theta'}.$
20. $\cot (\theta \pm \theta') = \frac{\cot \theta \cot \theta' \mp 1}{\cot \theta' \pm \cot \theta}.$
22. $\sin 2\theta = 2 \sin \theta \cos \theta.$
23. $\cos 2\theta = \cos^2 \theta - \sin^2 \theta = 2 \cos^2 \theta - 1 = 1 - 2 \sin^2 \theta.$
24. $\sin \frac{1}{2} \theta = \sqrt{\frac{1}{2}(1 - \cos \theta)}.$
26. $\sin \theta + \sin \theta' = 2 \sin \frac{1}{2}(\theta + \theta') \cos \frac{1}{2}(\theta - \theta').$
27. $\sin \theta - \sin \theta' = 2 \cos \frac{1}{2}(\theta + \theta') \sin \frac{1}{2}(\theta - \theta').$
28. $\cos \theta + \cos \theta' = 2 \cos \frac{1}{2}(\theta + \theta') \cos \frac{1}{2}(\theta - \theta').$
29. $\cos \theta - \cos \theta' = -2 \sin \frac{1}{2}(\theta + \theta') \sin \frac{1}{2}(\theta - \theta').$
8. $\sin (-\theta) = -\sin \theta.$
9. $\cos (-\theta) = \cos \theta.$
10. $\sin (90^\circ \pm \theta) = \cos \theta.$
11. $\cos (90^\circ \pm \theta) = \mp \sin \theta.$
12. $\sin (180^\circ \pm \theta) = \mp \sin \theta.$
13. $\cos (180^\circ \pm \theta) = -\cos \theta.$
14. $\sin (270^\circ \pm \theta) = -\cos \theta.$
19. $\tan 2\theta = \frac{2 \tan \theta}{1 - \tan^2 \theta}.$
21. $\cot 2\theta = \frac{\cot^2 \theta - 1}{2 \cot \theta}.$

In any plane triangle

30. $\frac{\sin A}{a} = \frac{\sin B}{b} = \frac{\sin C}{c}.$
31. $\frac{a+b}{a-b} = \frac{\tan \frac{1}{2}(A+B)}{\tan \frac{1}{2}(A-B)}.$
32. $a^2 = b^2 + c^2 - 2bc \cos A.$
33. $\text{Area} = \frac{1}{2} bc \sin A.$

ANSWERS

CHAPTER I

Page 4. — 7. $(x, -y), (-x, y), (-x, -y)$. 8. $(a\sqrt{2}, 0), (0, a\sqrt{2}), (-a\sqrt{2}, 0), (0, -a\sqrt{2})$. 9. $(0, 0), (2a, 0), (a, a\sqrt{3})$ for one position of the triangle. 10. On a line two units to the right of the x -axis. On a line three units below the y -axis. 11. Yes. Yes. No. 13. $y = x$, or $y = -x$. 14. On a circle with centre at the origin and radius equal to a ; $x^2 + y^2 = 4$. 15. $x = -5$, or $x = 1$. 16. $y = x + 3$.

Page 6. — 6. An isosceles triangle. 7. A parallelogram. 8. $(\sqrt{10}, \tan^{-1} \frac{1}{3}), (-\sqrt{2}, 45^\circ), (\sqrt{10}, \tan^{-1} 3), (3\sqrt{2}, 45^\circ)$. 9. $(0, 0), (2a, 0), (2a, 60^\circ); (a, 0), (a\sqrt{3}, 30^\circ), (a, 60^\circ)$. 10. $(0, 0), (2a, 0), (2a\sqrt{2}, 45^\circ), (2a, 90^\circ); (a, 0), (a\sqrt{5}, \tan^{-1} \frac{1}{2}), (a\sqrt{5}, \tan^{-1} 2), (a, 90^\circ)$. 11. $(0, 0), (2a, 0), (2a\sqrt{3}, 30^\circ), (4a, 60^\circ), (2a\sqrt{3}, 90^\circ), (2a, 120^\circ); (a, 0), (a\sqrt{7}, \tan^{-1} \frac{\sqrt{3}}{5}), (a\sqrt{13}, \tan^{-1} \frac{3\sqrt{3}}{5}), (a\sqrt{13}, \tan^{-1} 2\sqrt{3}), (a\sqrt{7}, \tan^{-1} -\frac{3\sqrt{3}}{2}), (a, 120^\circ)$.

12. ρ must vary from 0 to ∞ , while θ varies from 0 to 2π , or ρ must vary from $-\infty$ to $+\infty$, while θ varies from 0 to π . 19. $\rho = a \sec \theta$, where a is the distance from the pole to the line; $\rho = b \csc \theta$. 20. On a circle passing through the pole, with centre on the initial line and diameter a ; on a circle with diameter a , above the initial line and tangent to it at the pole.

Page 9. — 1. 13. 3. $2\sqrt{7}$. 4. $3\sqrt{5}, 3\sqrt{5}, 3\sqrt{2}$.

Page 10. — 3. $a\sqrt{5 - 2\sqrt{2}}$.

Page 11. — 1. $(-2, 1)$ and $(-1, 2), (4, 7)$ and $(-7, -4)$. 2. 2:3; $-(3:8)$.

Page 16. — 1. 13. 2. $2\frac{1}{2}\sqrt{3}$. 3. $12\frac{1}{2} + 6\sqrt{3}$. 4. $2\sqrt{3}$. 5. $8\sqrt{3}$. 6. $\frac{1}{4}a^2\sqrt{3}$. 7. $2ac$. 8. a^2 . 9. 31. 10. 47. 11. $(2\sqrt{3}, 2), (\sqrt{2}, -\sqrt{2}), (\frac{3}{2}, -\frac{3}{2}\sqrt{2})$. 12. $(5, \tan^{-1} -\frac{1}{4}), (13, \tan^{-1} -\frac{1}{2}), (\sqrt{10}, \tan^{-1} 3)$. 13. $(-\frac{1}{3}, 0), (\frac{1}{3}, 1)$. 14. $(-\frac{1}{2}, \frac{1}{2}), (-\frac{3}{4}, \frac{1}{4})$. 15. $(17, 1), (-13, 6)$. 16. Sides 13, 13, $7\sqrt{2}$. Medians $\frac{1}{2}\sqrt{365}, \frac{1}{2}\sqrt{365}, \frac{1}{2}\sqrt{2}$, isosceles. 17. Sides $4\sqrt{2}, 3\sqrt{2}, 5\sqrt{2}$, area 12, a rt. Δ . 18. Sides $2\sqrt{5}, 2\sqrt{5}, 3\sqrt{5}, 3\sqrt{5}$, area 24, a parallelogram. 19. $\rho = a$. 20. $\theta = \alpha$. 21. $\rho = 2a \sin \theta \tan \theta$. 22. $\rho = a \sec \theta \pm b$. 23. $y = mx$. 24. $x^2 - y^2 = a^2$. 25. $(x^2 + y^2)^3 = 4a^2x^2y^2$. 26. $(2x^2 + 2y^2 + ax)^2 = a^2(x^2 + y^2)$.

CHAPTER II

Page 19. — 1. $x^2 + y^2 >, <$, or $= 9$. 2. $(x + 3)^2 + (y - 1)^2 >, <$, or $= 16$.
3. $(x - a)^2 + (y - b)^2 >, <$, or $= r^2$.

Page 20. — 1. $y - x + 2 >, <$, or $= 0$. 2. $y + x - 3 >, <$, or $= 0$.

Page 21. — 1. $3x + 5y - 4 >, <$, or $= 0$.

2. $2(a - c)x + 2(b - d)y = a^2 + b^2 - c^2 - d^2$.

Page 22. — 1. The origin. All the plane except the origin. No locus in the plane. 2. The x -axis. No locus. All the plane except the x -axis. 3. The line $x = a$. All the plane to the right of the line $x = a$. All the plane to the left of the line $x = a$. 4. The line $y = b$. All the plane above this line. All the plane below this line. 5. The circular ring bounded by the circles $x^2 + y^2 = 4$ and $x^2 + y^2 = 9$. 6. The ring bounded by the concentric circles $(x - 2)^2 + (y - 3)^2 = 9$ and $(x - 2)^2 + (y - 3)^2 = 16$. 7. All the plane between the two lines $x = a$ and $x = b$. 8. A circle. All the plane outside of this circle. All the plane inside of this circle. 9. That part of the plane bounded by two circles passing through the pole, with centres on the initial line and diameters a and b . 10. Similar to No. 8. 11. Similar to Nos. 8 and 10. 12. $x = 2, x = \frac{5}{2}, x = 3, x = \frac{7}{2}$.

Page 33, § 25. — 1. n . 2. The values of ρ corresponding to $\theta = 0$ are the intercepts of the locus on the initial line. The values of θ corresponding to $\rho = 0$ give the direction of the lines tangent to the curve at the pole.

Page 33, § 26. — The points of intersection are: 1. $(\frac{2}{3}, \frac{1}{3})$. 2. $(-\frac{1}{7}, \frac{1}{7})$.
3. $(-2, -3)$. 4. $(0, 5), (3, 4)$. 5. $(8, 1)$. 6. Imaginary. 7. $(0, 0)$, $(-6, -2)$. 8. $(\frac{1}{4}a\sqrt{4}, a\sqrt{2})$. 9. $[a(2 + \sqrt{5}), 2a\sqrt{2 \pm \sqrt{5}}]$. 10. $(4a, 4a)$.
13. $6\frac{1}{2}$.

Page 37. — The loci of these equations are symmetrical with respect to:
1. y -axis. 2. y -axis. 3. x -axis. 4. x -axis. 5. Origin. 6. Origin. 7. x -axis.
8. y -axis. 9. Both axes, and the origin. 10. Origin. 11, 12, 13, 14, 15, 16. Both axes, and the origin. 17. Origin. 18. Nothing. 19. y -axis.
20. Nothing. 21. The origin, and the lines $y = x$ and $y = -x$. 22. y -axis.
23. Origin. 24. Origin. 25. The origin, and the lines $y = x$ and $y = -x$.
26, 27. The line $y = x$. 28. The origin, both axes, and both lines $y = x, y = -x$.
29. Both axes, and origin. 30. Origin. 31. Same as 28. 32. The line $y = x$.
33. Same as 28. 34. x -axis. 35. x -axis. 36. y -axis. 37. Origin. 38. Both axes, and origin. 39. The origin, and the lines $y = x, y = -x$.

Page 41, § 32. — 1. $x^2 + y^2 = \pm 2ry$. 2. a, b, r . 3. $(\mp 2, 0), 2$.
4. $(0, \mp 3), 3$. 5. $(-1, 2), \sqrt{5}$. 6. $(\frac{3}{2}, -\frac{5}{2}), \frac{1}{2}\sqrt{34}$. 7. $(-3, 2), 2$.
8. $(\frac{3}{2}, -1), 3$. 9. $(-3, -4), 6$. 10. $(\frac{5}{2}, 4), 4$. 11. $x^2 + y^2 \pm 2rx \pm 2ry + r^2 = 0$.

Page 41, § 33. — 1. (2), (3), (4) are of the first degree because the pole is on the circle. Hence any line through the pole can cut the circle in only one other point. In (1) the pole is outside if $a > r$, inside if $a < r$. 2. See formulæ in § 32.

Page 43. — 1. $\rho^2 = \frac{a^2 b^2}{b^2 \cos^2 \theta + a^2 \sin^2 \theta}$. Since the denominator is the sum of two squares, it can never be zero. Hence ρ can never be infinite. **2.** Outside, inside. **4.** (1) 10, 6, $(\pm 4, 0)$. (2) $4\sqrt{2}$, 4, $(\pm 2, 0)$. (3) 10, 8, $(0, \pm 3)$.

Page 44, § 36. — 3. $\rho^2 = \frac{a^2 b^2}{b^2 \cos^2 \theta - a^2 \sin^2 \theta}$. Infinite. **4.** (1) $(\pm 5, 0)$, $3x + 4y = 0$, $3x - 4y = 0$. (2) $(0, \pm \sqrt{41})$, $25y^2 - 16x^2 = 0$. (3) $(\pm 2\sqrt{5}, 0)$, $4x^2 - y^2 = 0$. (4) $(\pm \sqrt{2}, 0)$, $x^2 - y^2 = 0$. (5) $(0, \pm \sqrt{2})$, $x^2 - y^2 = 0$. (6) $(\pm \sqrt{5}, 0)$, $4x^2 - y^2 = 0$.

Page 44, § 37. — (2) (1, 0), $x = -1$. (3) $(-2, 0)$, $x = 2$. (4) $(\frac{3}{2}, 0)$, $2x = -3$. (5) (0, 2), $y = -2$. (6) $(0, -\frac{3}{2})$, $2y = 5$. (7) $(0, -3)$, $y = 3$.

Page 45. — 1. $y = 4x$. **3.** $2(a-c)x + 2(b-d)y = a^2 + b^2 - c^2 - d^2$. **5.** $x^2 + y^2 + 6x - 6y + 9 = 0$. **6.** $x^2 + y^2 \pm 8x \pm 8y + 16 = 0$. **7.** $(x-2)^2 + (y+6)^2 = (4 \pm 2)^2$. **11.** (1), (2), (4) a straight line; (3) a hyperbola. **12.** (1) a circle; (2) a hyperbola; (3) two hyperbolas; (4) two straight lines. **13.** $x^2 + y^2 = c^2 - a^2$. **14.** $x^2 + y^2 - 4x = 0$. **15.** $2ax = c^2$. **16.** A circle with centre at the centre of the square.

CHAPTER III

Page 51. — 1. When the line goes through the origin. When the line is parallel to the y -axis. **2.** $y = -\frac{1}{\sqrt{3}}x - \frac{10}{\sqrt{3}}$, $\frac{x}{-10} + \frac{y}{-10} = 1$, $\frac{x}{2} + \frac{\sqrt{3}y}{2} = -5$.

3. $y = \frac{3}{4}x + 6$, $\frac{x}{-8} + \frac{y}{6} = 1$, $-\frac{3}{8}x + \frac{1}{6}y = 2\frac{1}{4}$. **4.** $y = x - 6$, $\frac{x}{6} + \frac{y}{-6} = 1$, $\frac{x}{\sqrt{2}} - \frac{y}{\sqrt{2}} = 3\sqrt{2}$. **5.** $y = -\frac{5}{4}x + 5$, $\frac{x}{4} + \frac{y}{5} = 1$, $\frac{5}{\sqrt{41}}x + \frac{4}{\sqrt{41}}y = \frac{20}{\sqrt{41}}$.

6. $y = \frac{5}{12}x - 1\frac{1}{2}$, $\frac{x}{\frac{1}{3}} + \frac{y}{-1\frac{1}{2}} = 1$, $\frac{5}{12}x - 1\frac{1}{2}y = 1$. **7.** $y = \frac{1}{2}x + \frac{3}{4}$, $\frac{x}{-\frac{3}{2}} + \frac{y}{\frac{3}{4}} = 1$, $\frac{x}{\sqrt{5}} - \frac{2}{\sqrt{5}}y = -\frac{9}{2\sqrt{5}}$. **8.** $y = \frac{2}{3}x - \frac{4}{3}$, $\frac{x}{2} + \frac{y}{-\frac{4}{3}} = 1$, $\frac{2}{\sqrt{13}}x - \frac{3}{\sqrt{13}}y = \frac{4}{\sqrt{13}}$.

9. $y = -\frac{2}{3}x$, $\frac{2x}{\sqrt{13}} + \frac{3y}{\sqrt{13}} = 0$. **10.** $\frac{x}{a} = 1$, $x = a$. **11.** $y = 4$, $\frac{y}{4} = 1$, $y = 4$.

12. $\frac{AK}{A+B+C}x + \frac{BK}{A+B+C}y + \frac{CK}{A+B+C} = 0$; $\frac{3B}{A}x + \frac{3B^2}{A^2}y + \frac{3BC}{A^2} = 0$,

$\sqrt{\frac{2A(A+B+C)}{BC}}x + \sqrt{\frac{2B(A+B+C)}{CA}}y + \sqrt{\frac{2C(A+B+C)}{AB}} = 0$.

13. $-10x - 8y + 40 = 0$; $-\frac{1}{3}x - \frac{4}{25}y + \frac{4}{3} = 0$. **14.** $\frac{3}{4}x - 3y + 9 = 0$; $\pm \frac{3}{2}x \mp 2y \pm 6 = 0$. **15.** $-5x + 2y + 3 = 0$, or $20x - 8y - 12 = 0$; $10x - 4y - 6 = 0$, or $-15x + 6y + 9 = 0$.

Page 52. — 1. $\alpha = 30^\circ$, $p = 2$. **2.** $\alpha = 60^\circ$, $p = 1$. **3.** $\alpha = -45^\circ$, $p = 3$. **4.** $\alpha = -120^\circ$, $p = -4$. **5.** $\alpha = 120^\circ$, $p = -1$. **6.** $\alpha = -60^\circ$, $p = -5$.

7. $\rho \cos(\theta - \alpha) = p$. 8. $\rho \cos \theta = p$, $\rho \sin \theta = p$. 9. $\theta = k$, where k is any constant angle; $\theta = 0$. 10. $\theta = 0$; $\theta = 0$, and $\theta = 90^\circ$; $\theta = 0$, $\theta = 60^\circ$, and $\theta = 120^\circ$; n straight lines through the pole and equally inclined to each other. 11. Similar to Ex. 10. 12. $(0, \sqrt{2})$. 13. $\theta = 0$, and $\rho \cos(\theta - 45^\circ) = 2(\sqrt{6} - \sqrt{2})$.

Page 54.—1. $3x - 15y + 10 = 0$. 2. $x + y = \pm 5\sqrt{2}$. 3. $x - y\sqrt{3} = 8$. 4. $x\sqrt{3} + 3y + 9 = 0$. 5. $y = 2x - 10$. 6. $ax - by + a^2 + b^2 = 0$. 7. $x - 4y + 10 = 0$, $10x + 7y = 11$, $(a - 2b)x - by - a^2 + b^2 + 2ab = 0$. 8. $y + 4x = 7$, $x + 2y + 7 = 0$, $y = 3x$. 9. $x = 1$, $5x + 3y = 0$, $2x - 3y = 7$. 10. (1) $x + y = 3$, (2) $x - y + 5 = 0$. 11. $2x + 3y + 7 = 0$.

Page 57.—1. 45° . 2. 90° . 3. 45° . 4. $\tan^{-1} \frac{1}{2}$. 5. $\tan^{-1} \frac{a^2 - b^2}{2ab}$. 6. $\tan^{-1} 3\frac{1}{2}$. 7. $4x - 3y + 1 = 0$, $3x + 4y = 18$. 8. $y = 2x - 10$, $x + 2y = 0$. 9. $3x - 4y + 18 = 0$, $4x + 3y = 1$. 10. $10x - 4y = 5$. 11. $25x + 15y + 3 = 0$, $25x + 15y + 37 = 0$; $5x + 3y = 81$, $5x + 3y + 89 = 0$. 12. $3x + 4y = 20$. 13. (∞, ∞) . 14. $4x - 7y = 5$, $x + 5y = 13$, $5x - 2y = 18$. 15. $8x - 14y = 7$, $x + 5y + 5 = 0$, $10x - 4y + 3 = 0$. 16. $\tan^{-1} \frac{2}{3}$, $\tan^{-1} \frac{3}{4}$, $\tan^{-1} -\frac{2}{3}$. 17. $y = (16 \pm 17\sqrt{3})x$.

Page 60.—1. $12\frac{1}{2}$, -7 , 7 . 2. $-\sqrt{10}$, $-\sqrt{10}$, $\sqrt{10}$. 3. $-\frac{2}{3}$, $-\frac{4}{3}$, $-\frac{7}{3}$. 4. $-\frac{4ab}{\sqrt{a^2 + b^2}}$, $-\frac{(a+b)^2}{\sqrt{a^2 + b^2}}$, $\frac{(a-b)^2}{\sqrt{a^2 + b^2}}$. 5. $1\frac{1}{2}$, $-3\frac{1}{2}$, $-9\frac{1}{2}$. 6. $7x + y = 0$, $x - 7y = 24$. 7. $11x - 3y + 15 = 0$, $21x + 77y + 5 = 0$. 8. $x - y = 1$, $x + y + 13 = 0$. 9. $x(1 - \sqrt{3}) + y(1 + \sqrt{3}) = 12$, $x(1 + \sqrt{3}) - y(1 - \sqrt{3}) = 6$. 10. $\frac{17}{\sqrt{5}}$, $\frac{51}{\sqrt{58}}$, $\frac{51}{\sqrt{79}}$. 11. The two straight lines $2x - 4y = 9 \pm 6\sqrt{5}$.

Page 61.—1. $2x + 3y = 0$, $6x - 5y = 14$, $8x + 5y = 7$. 2. $9x - 4y = 23$. 3. $9x + 18y + 15 = 0$, $y = 2x$. 4. $38x - 19y + 2 = 0$, $76x - 57y = 444$. 6. $x^2 + y^2 - 10x = 0$. 7. (1) $x^2 + y^2 - 4x + 4y = 0$, (2) $x^2 + y^2 - 8x + 8y + 16 = 0$.

Page 63.—1. (1) $x = 0$ and $x + ay = 0$. (2) $x = 0$, $x + y = 0$, $x - y = 0$. (3) $x + y = 0$. (4) $x - y = 0$. (5) $ax + by = 0$, $ax - by = 0$. (6) The origin. (7) $x + 1 = 0$, $x - 1 = 0$, $y + 2 = 0$, $y - 2 = 0$. (8) $ax + by + c = 0$, $ax + by - c = 0$. (9) $y + x - a = 0$, $y - x + a = 0$. (10) The point (a, b) . (11) $x + y - a - b = 0$, $x - y - a + b = 0$. (12) $x = y$. (13) $x \cos \alpha + y \sin \alpha = a$. 2. $2x - 6y + 7 = 0$, $4x + 5y = 20$. 3. $x + 3y = 0$, $4x + 3y = 0$. 4. $ax - by = a^2 - b^2$. 5. $x + y + 1 = 0$, $y = x + 3$. 8. $\frac{2}{3}$, $\pm \sqrt{3}$. 9. $\rho \cos(\theta + 30^\circ) = \pm 3$, $x\sqrt{3} - y = \pm 6$. 10. $3x - 2y = 3$. 11. $2\frac{1}{2}$. 12. $(0, 3 \mp 2\sqrt{2})$, $(-21 \pm 20\sqrt{2}, 0)$. 13. $2x + 11y = 5$. 14. $\frac{bl - am}{\sqrt{l^2 + m^2}}$. 16. $10x - 6y = 9$. 21. $5x - 3y = 4$, $3x + 5y = 16$, $5x - 3y + 13 = 0$, $3x + 5y + 1 = 0$. 22. $y = (-2 \pm \sqrt{3})x + 75 \mp \sqrt{3}$, $y = (-2 \pm \sqrt{3})x + 1 \pm \sqrt{3}$. 25. $21\frac{1}{2}$. 28. (a) $7x - 7y + 40 = 0$ or $7x + 7y = 32$, (b) $2x + y = 4$. 29. $3x - 4y + 25 = 0$.

30. $x(30 \pm \sqrt{95}) - y(15 \mp 2\sqrt{95}) + 120 = 0$. 31. $x = 3, 12x + 35y + 104 = 0$.
 32. $7x - y = 46, 5x - 5y = 38$. 33. $x^2 + y^2 + 2x - 8y + 1 = 0, x^2 + y^2 + 50x - 200y + 625 = 0$.

CHAPTER IV

- Page 69. — 1. $y^2 = 4x$. 2. $2x^2 + 3y^2 = 1$. 3. $x^2 + y^2 = r^2$. 4. $xy = a^2$.
 5. $y^2 + 4ax = 0$. 6. $x^2 - y^2 = 0$. 7. $\frac{x^2}{a^2} + \frac{y^2}{b^2} = 1$. 8. $2xy + a^2 = 0$. 9. $x^2 + 2y^2 = 16$. 10. $x = y^3$. 11. $(a + h)x^2 + (a - h)y^2 = 1$. 12. $2y^2 = a(2x\sqrt{2} - a)$. 13. $(x^2 + y^2)^3 = a^2(x^2 - y^2)^2, \rho = a \sin 2\theta, \rho = a \cos 2\theta$.
 14. $x\sqrt{a^2 + b^2} = ab$. 15. $xy = \pm a^2$. 16. $2x^2 + 3y^2 = 1$. 18. 45° . 19. $\tan^{-1} \frac{1}{2}$, or $\tan^{-1} - 2$. 20. $\tan^{-1} \frac{3}{4}$, or $\tan^{-1} - \frac{4}{3}$. 21. $\frac{1}{2} \tan^{-1} \frac{2h}{a-b}$. 23. The two curves will be the same if the unit of the scale of the second is taken twice as large as the unit of the scale of the first.

CHAPTER V

- Page 71. — 1. $\frac{3}{2}a$. 2. $2a^2$. 3. 0. 4. $\frac{3}{2}$. 5. $2a$. 6. 2. 7. $\frac{1}{2}$. 8. 0.
 Page 75. — 1. 0, 3, 12, ... 2. 0, $\pm 3, \pm 32, \dots$. 3. $\infty, \mp 2, \mp \frac{1}{4}, \dots$.
 4. 0, $\pm \frac{3}{2}, \pm \frac{3}{2}\sqrt{2}, \dots$. 5. -4, -1, 8, ... 6. 0, $\mp 36, \mp 48, \dots$. 7. $-\frac{1}{4}, -1, \infty, -1, -\frac{1}{4}, -\frac{1}{8}, -\frac{1}{16}, \dots$, for x negative, $-\frac{1}{8}, -\frac{1}{16}, \dots$. 8. 0, $\pm \frac{1}{2}\sqrt{2}, \pm 1$. 9. 0, $\infty, \pm \frac{1}{2}\sqrt{3}$. 10. -.3, -.1, -.5, .5, -1, 1, ...
 Page 78. — 1. $3x + 4y = 25$. 2. $12x - 5y + 169 = 0$. 3. $y = x + 2, 2y = x + 8$. 4. $2x + y = 6$. 5. $y = 8x - 16, x + y = 2$. 6. $x + 3y = 4$.
 7. $2x - 3y = 0, 2x + 3y + 18 = 0$. 8. $3y = 4x - 8, 4x + 3y = 26, 4x + 3y + 24 = 0, 3y = 4x + 42$. 9. $x + 2y = 3, 2y = x + 5, 2y = x - 5, x + 2y = 13$. 10. $x = 3, 3x + 4y = 15, 4y = 3x + 17$. 17. $xx' - yy' = 1$.
 20. $xx'^{n-1} + yy'^{n-1} = 1$. 21. $x = 1; y = 1$. 22. $x + 2y = 3$. 23. $y = 2x - 8$.
 24. $2y = x + 9, x + 2y + 1 = 0$. 25. $3y = 4x - 1, 4x + 3y = 13$.
 26. $x - y = 0, x + y = 0, x = \pm a$. 27. The equation of the tangent at any point (α, β) on the curve is $\frac{\alpha^{n-1}x}{a^n} + \frac{\beta^{n-1}y}{b^n} = 2$, at the point $(a, b), \frac{x}{a} + \frac{y}{b} = 2$.
 30. $\tan^{-1} \frac{3}{4}$. 32. 90° . 33. 90° . 34. $\tan^{-1} 3\sqrt{\frac{5}{2}}$. 35. $2y = x + 4, 2x + y = 12, 45^\circ$.
 39. $\frac{4x}{(1-x^2)^2}$. 41. $\frac{-2bx}{(a-bx)^3}$. 42. $\frac{nx^{n-1}}{(1+x)^{n+1}}$. 53. $-\sin 2x$.
 55. $\tan^2 x$. 56. $3 \sec^4 x$. 57. $x \cos x$. 59. $2 \sec^2 x \tan x (\sec^2 x + \tan^2 x)$.
 61. $4x^3 + 2x(a+b)$. 62. $15x^4 + 3x(2a+bx)$. 63. $\frac{-4a^2x}{(a^2+x^2)^2}$.
 65. $\frac{a-3x}{2\sqrt{a-x}}$. 67. $\frac{2x+3x^3}{\sqrt{1+x^2}}$. 68. $6x(2x^3+3)(1-3x^2)^2(2x-12x^3-9)$.
 69. $\frac{1}{(1+x^2)^{\frac{3}{2}}}$. 71. $\frac{3x^2-x^4}{(1+x^2)^3}$. 73. $\frac{4x^2+1}{x^2(1+x^2)^{\frac{3}{2}}}$. 74. $(m \sin^2 x + n \cos^2 x)$
 $\left(\frac{\sin^{n-1}x}{\cos^{m+1}x} + \frac{\cos^{m-1}x}{\sin^{n+1}x} \right)$.

CHAPTER VI

- Page 86.** — 1. $\phi(x) = 2x^4 - 5x^2 - 5, R = 3.$ 2. 2, 4. 3. 4, 14. 4. $\pm\sqrt{2}$.
 5. $2 \pm \sqrt{3}$. 6. $\frac{7 \pm \sqrt{-95}}{12}$. 7. 1, -3, 4. 8. $\pm 1, 3, 5.$ 9. Two real roots,
 one between 0 and 1, the other between 4 and 5. 10. 2, -4, 10. 11. 3, and
 one root between 0 and 1, the other between -1 and -2. 12. 4, and one root
 between 0 and 1, the other between -2 and -3. 13. -3, 5, between 0 and 1,
 and between 3 and 4. 14. $x^3 + x^2 - 17x + 15 = 0.$ 15. $x^4 - 3x^3 - 28x^2$
 $+ 36x + 144 = 0.$ 16. $30x^3 + 77x^2 - 92x + 21 = 0.$ 17. $x^4 - 17x^2 + 16 = 0.$
 18. $x^4 - 2x^3 - 19x^2 + 20x = 0.$ 19. $x^4 - 5x^2 + 6 = 0.$ 20. $x^4 + 2x^3 + 2x^2$
 $+ 4x = 0.$ 21. $x^3 - 13x^2 + 50x - 60 = 0.$ 22. $x^4 - 6x^3 - 8x^2 - 66x - 65 = 0.$
 23. $x^5 - 3x^4 - 23x^3 + 51x^2 + 94x - 120 = 0.$ 24. $x^5 + 2x^4 - 16x^3 + 18x^2$
 $+ 15x = 0.$ 25. $6x^6 - 11x^5 - 10x^4 + 3x^3 + 2x^2 = 0.$ 26. $x^4 + 2x^3 + 9x^2$
 $+ 2x + 66 = 0.$ 27. $x^5 + 5x^4 - 20x^2 + 71x + 231 = 0.$

- Page 87.** — 1. -2. 2. $-\sqrt{3}.$ 3. -4. 4. 4. 5. 0, 0, 0, $3 + \sqrt{-3}.$
 6. 0, $-\frac{3}{2}.$ 7. 0, 0, $-\frac{3}{2}.$

- Page 90.** — 1. 1.879, -.347, -1.532. 2. 1.356, 1.692, -3.048. 3. 1.939.
 4. 3.264. 5. 1.769, 2.672, -4.441. 6. .593, 2.047. 7. 2.382, 4.618. 8. 3.128,
 1.201, -1.33. 9. .494, 2.861, -3.112. 10. 2.583, 7.169, -3.399, -6.353.

- Page 92.** 2. 3, -5, $2 - \sqrt{3}.$ 3. $\frac{3}{2}, 3 - \sqrt{-5}.$ 7. $x^4 + 2x^2 + 25 = 0.$
 8. $\pm\sqrt{2} \pm \sqrt{-1}, \frac{3 \pm \sqrt{-63}}{4}.$

- Page 95.** — 1. $x^2 + 4x - 5 = 0.$ 2. $x^3 - 6x^2 - 7x + 60 = 0.$ 3. $x^3 + 8x^2$
 $- 28x - 80 = 0.$ 4. $x^4 - 12x^2 - 12x + 3 = 0.$ 5. $x^3 - 4x^2 - 60x = 0.$
 6. $x^4 - 4x^3 + x^2 + 6x = 0.$ 7. $x^4 - 11x^3 + 36x^2 - 30x = 0.$ 8. $x^2 - 25 = 0.$
 9. $x^3 - 4x - 2 = 0.$ 10. $x^4 - 35x^2 - 90x + 304 = 0.$ 11. (1) $c = -2,$ (2) $c = 1,$
 or -5. 12. $x^3 + 6x^2 - 32 = 0,$ or $x^3 - 6x^2 = 0.$ 13. $9x^2 + 8x - 1 = 0.$
 14. $12x^3 + 13x^2 - 3x - 2 = 0.$ 15. $24x^4 + 20x^3 - 30x^2 - 5x + 6 = 0.$ 19. 1, 2,
 $\frac{1}{2}.$ 20. -1, $\frac{3}{2}, \frac{3}{2}.$ 21. -1, $\frac{-1 \pm 2\sqrt{-2}}{3}.$ 22. 1, $\frac{1 \pm 2\sqrt{-6}}{5}.$ 23. 1, $\frac{-7 \pm \sqrt{33}}{4}.$
 24. $\pm 1, \frac{3}{2}, \frac{3}{2}.$ 25. $\pm 1, \frac{7 \pm \sqrt{-95}}{12}.$ 26. -2, $-\frac{1}{2}, 2 \pm \sqrt{3}.$ 27. -1, $\frac{1}{2}, 2,$
 $-\frac{9 \pm \sqrt{-115}}{14}.$ 28. $\pm 1, \frac{1}{2}, 2, \frac{-1 \pm 2\sqrt{-6}}{5}.$

- Page 97.** — 1. (2, -16), (-2, 16). 2. (1, 16), (4, -11). 3. (0, 32),
 (4, 0). 4. (-1, -67), (3, 189). 5. (0, 10), (2, -54), (-2, 74).
 6. (1, 73), (-3, -567), (4, -224).

- Page 100.** — 1. -6, -6, 1. 2. 3, 3, -4. 3. 3, 3, 3, -2. 4. 2, 2, 3, 4.
 5. 3, 3, 3, -4. 6. 2, 2, 2, -3, -3. 7. -1, -1, -1, 2, 2. 8. 3, 3, -2, -2.
 9. 1, 1, 1, $\frac{-3 \pm \sqrt{-15}}{2}.$ 10. 2, 2, 2, -3. 11. 1, 1, 1, 1, -4. 12. -4, -4,

- 4, 2. 13. -5, -5, -5, -5, 1. 14. 2, 2, 2, -1, -1, 1. 15. $1 \pm \sqrt{2}$, $1 \pm \sqrt{2}$, -2. 16. $-2 \pm \sqrt{3}$, $-2 \pm \sqrt{3}$, -2, 3. 17. $1 \pm \sqrt{-1}$, $1 \pm \sqrt{-1}$, -4. 18. $-1 \pm \sqrt{-2}$, $-1 \pm \sqrt{-2}$, 4. 19. $4q^3 + 27r^2 = 0$.

- Page 104. -1. 4, -4, 0. 2. -36, 18. 3. 108. 5. $34\frac{2}{5}$. 6. $\frac{1}{3}a^2$. 7. $\frac{3}{2}\sqrt{2}$. 8. $\frac{1}{3}$. 10. 1. 11. $\frac{4}{3}$. 12. $9a^2$. 15. $\frac{1}{2}$.

- Page 111. -1. Max. 4; min. 0; (1, 2). 2. Max. 4; min. -28; (3, -12). 3. Neither a max. nor a min.; (1, 11). 4. Max. 36; min. 32; (3, 34). 5. $r\sqrt{2}$; $r\sqrt{2}$ and $\frac{1}{2}r\sqrt{2}$. 6. $a\sqrt{2}$ and $\frac{1}{2}b\sqrt{2}$. 7. $\frac{2}{3}$ the altitude of the segment. 8. The square with corners at the middle points of the sides of the given square. 9. $\frac{1}{3}$ the altitude of the cone. 10. $h=r$. 11. $h=2r$. 12. $h=\frac{3}{2}r$. 13. $2 \times 8 \times 8$. 14. $\frac{1}{8}(a+b-\sqrt{a^2-ab+b^2})$, where a, b are the sides of the given rectangle. 15. He must walk one mile. 16. 6 miles an hour. 17. $\frac{2}{3}r\sqrt{3}$. 18. $\frac{2}{3}r$. 19. $\frac{4}{3}r$. 20. $\frac{4}{3}r$. 21. $\sqrt{2}$. 22. $r = \sqrt{\frac{S}{\pi\sqrt{3}}}$, $h = \sqrt{\frac{2S}{\pi\sqrt{3}}}$. 23. 4 r. 24. $\frac{1}{2}$ the altitude of the paraboloid. 27. 10.392 in. and 14.697 in.

CHAPTER VII

Page 117. -5. The two foci of a circle coincide at the centre, and the directrices are at an infinite distance from the centre; one focus and one directrix of a parabola are in the infinite region of the plane; in the case of two intersecting lines the two foci coincide with the point of intersection of the lines, and the two directrices also coincide and pass through this same point.

- Page 130. -1. $2x + y + 2 = 0$, $2y = x + 6$. 2. $x + y + 2 = 0$, $y = x - 6$. 3. $4x - 3y = 25$, $3x + 4y = 0$. 4. $5x + 3y + 16 = 0$, $3x - 5y + 30 = 0$. 5. $x - 2y + 4 = 0$, $2x + y + 3 = 0$. 6. $x + 2y + 2 = 0$, $2x - y = 6$. 7. $x = 0$. 8. $2x + 3y = 0$. 9. $5x - 3y = 0$. 10. $2x - y = 0$. 11. Put the *first degree terms* of the equation of the conic equal to zero; the result will be the equation of the tangent at the origin. 12. $2y = 3x + 6$. 13. $x + 2y + 2 = 0$. 14. $2x + 3y = 1$. 15. $2x - y + 7 = 0$. 16. The equation of the polar of the origin with respect to a conic is found by putting *half of the first degree terms plus the constant term* of the equation of the conic equal to zero. 17. $y = x + 1$, $2y = x + 4$. 18. $6y = 5x + 9$, $x + 2y + 5 = 0$. 19. $3y = 4x + 25$, $3x + 4y = 25$. 20. $y + 3 = 0$, $4x + 5y = 25$. 24. The line at infinity. At infinity. 25. $\left(\frac{r^2 \cos \alpha}{p}, \frac{r^2 \sin \alpha}{p}\right) \cdot (-p \sec \alpha, -\tan \alpha)$.

CHAPTER VIII

Page 131. -3. It passes through the point (x, y') and is perpendicular to the polar of this point.

Page 133. — 1. Tangents, $y = x + a$, $y = -x - a$; normals, $y = -x + 3a$, $y = x - 3a$. 3. $y = \sqrt{3}(x + 1)$. 4. $2y = 2x + 3$. 5. $V(-2, 0)$, $F(-\frac{3}{2}, 0)$, L.R. = 3, directrix $x = -2\frac{3}{2}$. 6. $V(-2, 2)$, $F(-2, \frac{3}{2})$, L.R. = 2, directrix $y = 2\frac{1}{2}$. 7. $V(-2, 4)$, $F(-\frac{1}{2}, 4)$, L.R. = 6, directrix $x = 3\frac{1}{2}$. 8. $V(3, -1)$, $F(3, -1\frac{3}{8})$, L.R. = $\frac{3}{8}$, directrix $y = -1\frac{3}{8}$. 9. $V(1, 3)$, $F(-1, 3)$, L.R. = 8, directrix $x = 3$.

Page 136. — 1. $y = x - 1$. 2. $3x - 4y + 1 = 0$. 3. $2y = x + 6$, $3x + 2y + 2 = 0$. 5. (1) $(a, \pm 2a)$, (2) $(0, 0)$ and $(3a, 2a\sqrt{3})$. 7. $y + x\sqrt{\frac{a}{b}} + a\sqrt{\frac{b}{a}} = 0$. 24. (1) $y = kx$, (2) $kx^2 - y^2 + 2ax = 0$, (3) $kx = a$, where k is the constant. 26. $y^2 = ax$, where $y^2 = 4ax$ is the given parabola. 27. $y^2 = a(2x - a)$. 28. $y^2 - 2ax - ky + 2ah = 0$, (1) $y^2 = 2a(x - a)$, (2) $y^2 = 2ax$, (3) $y^2 = 2a(x - 4a)$, (4) $y^2 = 2a(x + a)$.

CHAPTER IX

Page 142. — 1. $2(x^2 + y^2) - 14x - 11y + 12 = 0$. 2. $x^2 + y^2 - 4x + 2y = 0$. 3. $x^2 + y^2 + 8x + 20y + 31 = 0$. 4. $x^2 + y^2 - 13x - y + 10 = 0$. 5. $2x + 3y = \pm 2\sqrt{13}$. 6. $3x - 2y = 9 \pm 3\sqrt{13}$. 7. $x + 2y = 5$. 8. $9x - 6y = 14$. 9. $5x - 4y = 14$. 10. $(4, 2)$, $(2, -6)$. 11. $(2, -4)$, $(3, \frac{3}{2})$. 12. $(-3, 2)$.

Page 143. — 1. The point (x', y') is then inside the circle. 2. The product of the segments of any chord (or secant) drawn through the origin. 3. The origin is outside, on, or inside the circle according as c is positive, zero, or negative.

Page 146. — The products of the segments of the chords in examples 1 to 6 are: 1. 9, 37. 2. -12, 7. 3. 15, -4. 4. $-1\frac{1}{2}$, $7\frac{1}{2}$. 5. 4, 25. 6. -11, 94. 7. $5x - 6y + 4 = 0$. 8. $16x + 8y = 17$. 9. $b(a - b)y = ac$. 10. $x - y = 0$, $\sqrt{\frac{1}{2}(a + b)^2 - 4c}$. 12. $(0, \frac{5}{3})$. 13. $(0, 0)$. 14. $y = m(x - a) + b$, where (a, b) is the centre. 15. One, viz. the line through the given point and the centre. 16. $x^2 + y^2 - 6x - 4y = 0$. 17. $x^2 + y^2 - 6x - 8y + 9 = 0$. 18. $x^2 + y^2 + 6x - 6y + 9 = 0$, $x^2 + y^2 + 30x - 30y + 225 = 0$. 19. $4(x^2 + y^2 \pm cx - cy) + c^2 = 0$. 20. $2x + 5y = 9$. 21. $x + 5y + 13 = 0$. 23. $9x + 12y = 29$, $9x + 12y + 71 = 0$. 25. $(2, -3)$. 26. (1) $x + my = \pm r\sqrt{1 + m^2}$, (2) $rx \pm y\sqrt{c^2 - r^2} = cr$, (3) $x \pm y = \pm r\sqrt{2}$. 27. $14x - 12y + 29 = 0$. 28. $ax - by = a^2$. 29. $(\frac{5}{8}\frac{9}{2}, \frac{5}{8}\frac{5}{1})$. 30. $(-2a, 2b)$. 34. $c_1 = c_2 = c_3$, where c_1, c_2, c_3 are the constant terms in the equations of the circles. 35. $3(x^2 + y^2) - 6x - 8y = 0$, $1: \sqrt{-2}$. 36. Imaginary. 37. $1: \sqrt{3}$. 39. $2y = \pm x\sqrt{5}$, and $2y \pm x\sqrt{77} + 24 = 0$. 42. $4(x^2 + y^2) - 29x + 12y + 25 = 0$. 43. $2x + y = 1$. 44. The circle $(x^2 + y^2)(\lambda^2 - 1) - \lambda^2(2ax - a^2 + r^2) = 0$, where $(0, 0)$ is the fixed point, λ the constant ratio, and $(x - a)^2 + y^2 = r^2$ is the fixed circle. The locus will be a straight line if $\lambda = 1$. 47. $(2, 0)$, $(5, 0)$. 49. $x^2 + y^2 = 2r^2$. 50. $x^2 + y^2 = r^2 \csc^2 \frac{\alpha}{2}$. 53. The radius of the circle is $\frac{1}{2}(a + b \pm \sqrt{a^2 + b^2})$.

CHAPTER X

Page 150.—1. $\frac{(x \pm ae)^2}{a^2} + \frac{y^2}{b^2} = 1$, $\frac{x^2}{a^2} + \frac{y^2}{b^2} \pm \frac{2x}{a} = 0$, $\frac{(x-h)^2}{a^2} + \frac{(y-k)^2}{b^2} = 1$.

2. It is perpendicular to the polar of the point (x', y') with respect to the conic.

Page 151.—3. Four.

Page 153.—1. In the case of the ellipse the reflected rays would *converge* and meet in the other focus. In the hyperbola the reflected rays would *diverge*, taking the directions of lines which meet in the other focus. 2. $ae^2, 0, a(e^2-1)$;

$0, \frac{be^2}{e^2-1}, 0$.

Page 154.—1. $\frac{1}{2}\sqrt{2}, (\pm\sqrt{2}, 0)$, 2. 2. $\frac{1}{2}\sqrt{13}, (\pm\sqrt{13}, 0)$, $\frac{5}{3}$. 3. $\frac{1}{2}\sqrt{3}, (0, \pm\sqrt{6}), \sqrt{2}$. 4. 2, $(\pm 2\sqrt{3}, 0)$, $6\sqrt{3}$. 5. $\frac{1}{2}, (1 \pm \frac{1}{2}\sqrt{3}, -2)$, $\frac{1}{2}\sqrt{3}$. 6. $\frac{1}{2}\sqrt{7}$, $(-1, 1 \pm \frac{1}{2}\sqrt{21})$, $\frac{1}{2}\sqrt{3}$. 7. $\frac{x^2}{16} + \frac{y^2}{12} = 1$. 8. $\frac{x^2}{16} + \frac{y^2}{8} = 1$. 9. $x^2 - y^2 = 8$. 10. $\frac{1}{2}\sqrt{3}, x^2 + 4y^2 = a^2$. 11. $3x^2 - y^2 = 12$. 12. $3x^2 + 5y^2 = 32; 3y^2 - 7x^2 = 20$. 13. $\frac{1}{2}, 3x^2 + 4y^2 = 3a^2; 2, 3x^2 - y^2 = 3a^2$. 17. $y = x \pm 2\sqrt{5}, y = x\sqrt{3} \pm 2\sqrt{13}$.

Page 161.—1. $(-3, -\sqrt{3}), 210^\circ$. 6. $x^2 + y^2 = a^2$. 7. The locus of Q is a circle with centre at the other focus and radius $2a$.

Page 167.—1. $8x + 27y = 0$. 2. $5x + 8y + 30 = 0$. 3. $y = x + 3$.

Page 169.—1. $b^2x + a^2y = 0, b^2x - a^2y = 0, b^2x + a^2y = 0, bx + ay = 0$, where $b^2x^2 + a^2y^2 = a^2b^2$ is the conic. 2. $x - y = 0$ and $x + 2y = 0$. 3. $32x + 9y = 0$. 4. $x + 3y = 0$ and $12x - 25y = 0$. 5. $2x + 3y = 5$.

Page 175.—3. (1) $\tan^{-1} \frac{b}{a}$, (2) $\tan^{-1} \sqrt{\frac{b}{a}}$, (3) 45° . 5. $bx + aey = 0$ and $bex - ay = 0$. 6. $2x + 3y = 0$ and $6x + 5y = 0$. 13. $y = \pm x \pm \sqrt{a^2 \pm b^2}$, $\left(\frac{\pm a^2}{\sqrt{a^2 \pm b^2}}, \frac{\pm b^2}{\sqrt{a^2 \pm b^2}} \right)$. 16. $\frac{-b^4}{a^2 \sin^2 \theta \pm b^2 \cos^2 \theta}$, where θ is the angle the chord makes with the axis of the conic. 40. An ellipse with major axis equal to the semi-major axis, and minor axis equal to the semi-minor axis of the given ellipse.

CHAPTER XI

Page 187.—The standard forms of these equations may be written as follows:

1. $y^2 = -\frac{4}{3}x$. 2. $y^2 = 3x$. 3. $\frac{x^2}{2} + \frac{y^2}{4} = 1$. 4. $\frac{y^2}{4} - \frac{x^2}{8} = 1$. 5. $\frac{y^2}{4} - \frac{x^2}{16} = 1$.
 6. $\frac{x^2}{9} + \frac{y^2}{4} = 1$. 7. $\frac{x^2}{6} + \frac{y^2}{36} = 1$. 8. $\frac{y^2}{4} - \frac{9x^2}{68} = 1$. 9. $y^2 = \frac{10}{\sqrt{13}}x$.
 10. $\frac{x^2}{5 + \sqrt{5}} + \frac{y^2}{5 - \sqrt{5}} = 4$. 11. $\frac{x^2}{2} - \frac{y^2}{3} = 1$. 12. $y^2 = \frac{3}{\sqrt{2}}x$. 13. $(x - 3y - 1)^2 = 0$.
 14. $y^2 = -\frac{2}{\sqrt{5}}x$. 15. $\frac{x^2}{5 - \sqrt{2}} + \frac{y^2}{5 + \sqrt{2}} = 2$. 16. $y^2 - x^2 = 40$, or $xy = -20$.

17. $\frac{x^2}{4} + \frac{y^2}{1} = 1$. 18. $\frac{x^2}{9} - \frac{y^2}{4} = 1$. 19. $9y^2 - 16x^2 = 202$. 20. $(5x - 2y - 2)(5x - 2y + 3) = 0$. 21. $\frac{x^2}{\sqrt{85} + 2} - \frac{y^2}{\sqrt{85} - 2} = \frac{1}{2}$. 22. $(2x - 3y + 1)(x + 2y - 3) = 0$. 23. $y^2 = \frac{7}{\sqrt{2}}x$. 24. $(x + y + 1)(x - 2y - 2) = 0$. 25. $y^2 - x^2 = 10\sqrt{2}$. 26. $y^2 = \frac{510}{13^3}x$. 27. $x^2 = 3y$.

EXAMPLES ON LOCI

Page 188.—2. A parabola whose focus is the centre of the fixed circle. 3. A hyperbola, an ellipse, or a circle. 4. A circle having the line joining the fixed point and the centre of the given circle for a diameter. 5. An ellipse whose axes are the fixed rods. 6. A hyperbola, with one focus at the rifle and the other at the target. 7. The two circles $\rho = \pm r \sin \theta$, where r is the radius of the given circle, and θ is the angle BOC . 8. A circle with its centre on the line AB . 9. A rectangular hyperbola with centre at O . 10. A circle passing through the points B and C . 11. Two circles passing through the points A and B , and having their centres on the given circle. 12. A circle passing through O . 13. A circle with centre at the centre of the given triangle. 14. A circle tangent to the two equal sides of the triangle at the ends of the base.

MISCELLANEOUS PROBLEMS ON LOCI

2. A sinusoid. 3. A sinusoid. 4. This problem would be the same as No. 2, if the cylinder in No. 2 were an elliptic cylinder. 5. Let a = the distance the fly crawls in a unit of time, ω = the angle through which the wheel turns in a unit of time, and t = the time. Then $\rho = at$ and $\theta = \omega t$. Hence the polar equation of the locus is $\rho = \left(\frac{a}{\omega}\right)\theta$. If ω represents the number of revolutions the wheel makes in a unit of time, the equation is $\rho = \left(\frac{a}{2\pi\omega}\right)\theta$. 6. A series of parallel lines. 7. A sinusoid. 12. A rectangular hyperbola. 14. A series of confocal hyperbolas with foci at the centres of the waves. 15. The locus in the plane is a circle. In space the locus is a sphere. 16. A parabola with its axis vertical. 18, 19, 20, 21. If the axes are rectangular, these curves are all rectangular hyperbolas. 23. $a = p(1 + r)^t$, where a represents the amount, p the principal, r the rate per annum, t the number of years. If the interest is calculated at n equal intervals each year and added to principal as soon as it is earned, this equation becomes $a = p\left(1 + \frac{r}{n}\right)^{nt}$. If we put $n = mr$, so that when n becomes infinite m also becomes infinite, the equation may be written $a = p\left[\left(1 + \frac{1}{m}\right)^m\right]r^t$. If now n becomes infinite, we approach the condition in which the interest is added on *continuously*. The equation then becomes $a = pe^{rt}$, where e is the base of Napierian logarithms. This is known as the *Compound Interest Law*.

SOLID GEOMETRY

CHAPTER XII

Page 194. — 1. $x = 0, y = 0, z = 0$. $z = 0, y = 0; x = 0, z = 0; x = 0, y = 0$. 2. The planes bisecting the angles between the coordinate planes. 3. The lines through the origin equally inclined to the coordinate axes. 6. $bx = ay, cy = bz, az = cx$.

Page 199. — 1. $\pm \frac{1}{\sqrt{3}}, \pm \frac{1}{\sqrt{3}}, \pm \frac{1}{\sqrt{3}}$. 2. 45° or 135° . 3. 60° or 120° . 4. $0, m, n$, where $m^2 + n^2 = 1$. $l, 0, n$, where $l^2 + n^2 = 1$. $l, m, 0$, where $l^2 + m^2 = 1$. 5. $1, 0, 0; 0, 1, 0; 0, 0, 1$. 6. $\frac{3}{\sqrt{14}}, -\frac{2}{\sqrt{14}}, -\frac{1}{\sqrt{14}}, -\frac{3}{7}, \frac{2}{7}, \frac{3}{7}$. 7.
$$\frac{x_1 - x_2}{\sqrt{(x_1 - x_2)^2 + (y_1 - y_2)^2 + (z_1 - z_2)^2}}, \frac{y_1 - y_2}{\sqrt{(x_1 - x_2)^2 + (y_1 - y_2)^2 + (z_1 - z_2)^2}}, \frac{z_1 - z_2}{\sqrt{(x_1 - x_2)^2 + (y_1 - y_2)^2 + (z_1 - z_2)^2}}$$

CHAPTER XIII

Page 203. — 1. Straight lines. 2. Circles. 3. The xy -contour is the circle $x^2 + y^2 = c^2$; the other contours are all straight lines parallel to the z -axis. The locus is a circular cylinder around the z -axis.

Page 207. — 4. (1) The sphere $x^2 + y^2 + z^2 = c^2 - a^2$; (2) the plane $2ax = c^2$. 7. A sphere with centre at the centre of the cube. 8. If the ellipse $\frac{x^2}{a^2} + \frac{y^2}{b^2} = 1$ is revolved about its major axis, the equation of the generated surface is $\frac{x^2}{a^2} + \frac{y^2}{b^2} + \frac{z^2}{b^2} = 1$, if revolved about the minor axis the equation is $\frac{x^2}{a^2} + \frac{y^2}{a^2} + \frac{z^2}{b^2} = 1$. The equations of the surfaces generated by the hyperbola $\frac{x^2}{a^2} - \frac{y^2}{b^2} = 1$ are $\frac{x^2}{a^2} - \frac{y^2}{b^2} - \frac{z^2}{b^2} = 1$ and $\frac{x^2}{a^2} + \frac{y^2}{a^2} - \frac{z^2}{b^2} = 1$. The equation of the surface generated by revolving the parabola $y^2 = 4ax$ about its axis is $y^2 + z^2 = 4ax$. 9. The equation of the surface generated by revolving the parabola $z^2 = 4ax$ around the z -axis is $16a^2(x^2 + y^2) = z^4$. 10. The paraboloid of revolution $y^2 + z^2 = 4a(x - a)$. 11. (1) $\frac{x^2}{a^2} + \frac{y^2}{b^2} + \frac{z^2}{b^2} = 1$, where $b^2 \equiv a^2 - c^2$. (2) $\frac{x^2}{a^2} - \frac{y^2}{b^2} - \frac{z^2}{b^2} = 1$, where $b^2 \equiv c^2 - a^2$. 12. $y = x \tan az$, where a depends upon the number of turns the blade makes per unit of length.

CHAPTER XIV

Page 214. — The symmetric equations may be written as follows:

$$2. \frac{x}{2} = \frac{y-3}{-5} = \frac{z-2}{-3} \quad 3. \frac{x}{1} = \frac{y-4}{2} = \frac{z-3}{3} \quad 4. \frac{x+2}{3} = \frac{y}{1} = \frac{z-7}{-5}$$

$$5. \frac{x}{2} = \frac{y-2}{3} = \frac{z-4}{0} \quad 6. \frac{x-\frac{1}{2}}{1} = \frac{y}{1} = \frac{z-3\frac{1}{2}}{-1} \quad 7. \frac{x-a}{l} = \frac{y-b}{m} = \frac{z-c}{0}$$

a line perpendicular to the z -axis; $\frac{x-a}{0} = \frac{y-b}{0} = \frac{z-c}{1}$, perpendicular to

the plane $z=0$.

$$8. x-2 = y+3 = z-1.$$

$$9. \frac{x+1}{3} = \frac{y-3}{-6} = \frac{z-2}{-2}$$

$$10. \frac{x}{l} = \frac{y}{m} = \frac{z}{n} \quad 11. (0, 6, 3).$$

$$\text{Page 216. — 3. } \cos^{-1} \frac{1}{3} = 70^\circ 32'.$$

$$4. 60^\circ.$$

$$5. \cos^{-1} \frac{\sqrt{6}}{3} = 35^\circ 16'.$$

$$8. \frac{x-1}{3} = \frac{y-4}{-2} = \frac{z-3}{4} \quad 10. \cos^{-1} -\frac{1}{3} = 109^\circ 28'.$$

Page 218. — 8. A plane. **13.** If the equations of the two fixed lines are $y+mx=0$, $z+c=0$, and $y-mx=0$, $z-c=0$ (§ 147), the equation of the locus is $y^2 - m^2x^2 = (m^2 - 1)(z^2 - c^2)$.

14. Let the equations of the two fixed lines be taken as in Ex. 13, and let $2l$ be the constant length of the moving line. Then the equation of the surface is $c^2(cy - mxz)^2 + m^2c^2(cmx - yz)^2 + m^2(c^2 - l^2)(c^2 - z^2)^2 = 0$. The locus described by any fixed point on the line is found by putting $z = k$ in this equation, where k is any constant.

15. If the fixed lines are the same as in Ex. 13, the equation of the surface is $yz - cmx = 0$.

CHAPTER XV

Page 222. — 1. The constant term D represents the square of the length of any tangent drawn from the origin to the sphere, or the product of the segments into which the origin divides any chord passing through the origin. The origin is outside, on, or inside the sphere, according as D is positive, zero, or negative. If $r_1r_2 = -d^2$, P is at the centre of the sphere.

2. Four, since there are four independent constants in the general equation.

3. The equation of a sphere through the four points (x_1, y_1, z_1) , (x_2, y_2, z_2) , (x_3, y_3, z_3) , (x_4, y_4, z_4) may be written:

$$\begin{vmatrix} x^2 + y^2 + z^2 & x & y & z & 1 \\ x_1^2 + y_1^2 + z_1^2 & x_1 & y_1 & z_1 & 1 \\ x_2^2 + y_2^2 + z_2^2 & x_2 & y_2 & z_2 & 1 \\ x_3^2 + y_3^2 + z_3^2 & x_3 & y_3 & z_3 & 1 \\ x_4^2 + y_4^2 + z_4^2 & x_4 & y_4 & z_4 & 1 \end{vmatrix} = 0.$$

$$4. (1, 2, 3), r = 3, \text{ outside, } t = \sqrt{5}; \text{ intercepts } 1 \pm 2\sqrt{-1}; 2 \pm \sqrt{-1}; 1, 5.$$

$$5. (-5, 12, 0), r = 13, \text{ on, } t = 0; \text{ intercepts } 0, -10; 0, 24; 0, 0.$$

$$6. (-3, 4, -1), r = 6, \text{ inside, } t = \sqrt{-10}; \text{ intercepts } -3 \pm \sqrt{19}; 4 \pm \sqrt{26}; -1 \pm \sqrt{11}.$$

$$7. (2, -3, -5), r = \sqrt{38}, \text{ on, } t = 0; \text{ intercepts } 0, 4; 0, -6; 0, -10.$$

$$8. x^2 + y^2 + z^2 \pm 2rx = 0. \quad 9. (x \pm r)^2 + (y \pm r)^2 + (z - c)^2 = r^2.$$

$$10. (x \pm r)^2 + (y \pm r)^2 + (z \pm r)^2 = r^2. \quad 11. x^2 + y^2 + z^2 \pm 2ax \pm 2ay \pm 2cz + a^2 = 0.$$

$$12. x^2 + y^2 + z^2 \pm 2ax \pm 2ay \pm 2az + a^2 = 0. \quad 13. x^2 + y^2 + z^2 - 4x - 4y \pm 4z + 4 = 0,$$

$$\text{and } x^2 + y^2 + z^2 - 20x - 20y \pm 20z + 100 = 0.$$

19. The radical axis of three spheres is the locus of all points from which tangents drawn to the spheres are equal. The radical centre of four spheres is the point from which tangents drawn to the four spheres are all equal. If D_1, D_2, D_3, D_4 are the constant terms in the equations of the circles, the condition is $D_1 = D_2 = D_3 = D_4$.

Page 237. — 3. Sections of the two surfaces are equal, if their planes are parallel to the yz -plane, and the difference of the squares of their distances from this plane is equal to a^2 .

12. In both cases the asymptotic cone passes entirely into the infinite region.

Page 243. — 6. $x^2 + y^2 + z^2 = a^2$. 11. $(x-a)^2 + (y-b)^2 + (z \pm \sqrt{b^2 - a^2})^2 = 13^2$. The area of the section made by the plane $x = 0$ is independent of r , because a variation in r causes no change in the size of the sphere, or of its distance from the yz -plane; it produces a change only in the z coordinate of the centre.

APPENDIX

Page 246. — 1, 2, 3. The same as the x -axis. 4. The y -axis. 5. The x -axis.
 6. The lines $y = x$ and $y = -x$. 7. At $(0, 0) y = 2x$, at $(1, 0) y = -x + 1$,
 at $(2, 0) y = 2x - 4$. 8. At $(0, 0) y = 0$, at $(1, 0) y = 2x - 2$, at $(-1, 0)$
 $y = -2x - 2$. 9. At $(0, 0) y = -6x$, at $(-2, 0) y = 10x - 20$, at $(3, 0)$
 $y = 15x - 45$. 10. At $(0, 12) y = 11x + 12$, at $(1, 0) y = -12(x - 1)$,
 at $(-3, 0) y = 28(x + 3)$, at $(4, 0) y = 21(x - 4)$.

$$\sqrt{2} = 1.414$$

$$\sqrt{3} = 1.732$$





14 DAY USE
RETURN TO DESK FROM WHICH BORROWED
ASTRONOMY, MATHEMATICS-
STATISTICS LIBRARY

This book is due on the last date stamped below, or
on the date to which renewed.

Renewed books are subject to immediate recall.

OCT 17 1962	AUG 18 1967
LIBRARY USE	AUG 26 1969
OCT 3 1963	
DEC 11 1963	JUN 16 1970
JAN 20 1964	OCT 22 1970
OCT 21 1964	NOV 9 1970
NOV 20 1964	
LIBRARY USE	
DEC 14 1964	
MAY 13 1965	
APR 15 1966	
NOV 8 1966	
NOV 29 1966	

LD 21-50m-6, '60
(B1321s10)476

General Library
University of California
Berkeley

QASSI
C2

- 230

