

UC-NRLF

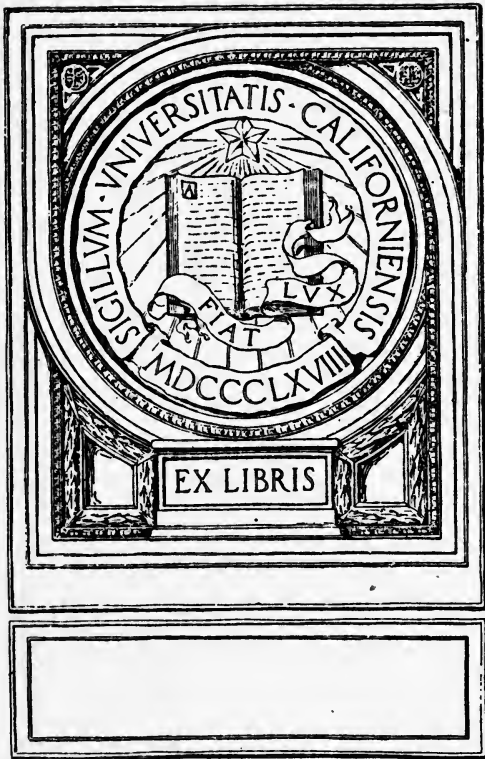

\$B 32 189



EX LIBRIS

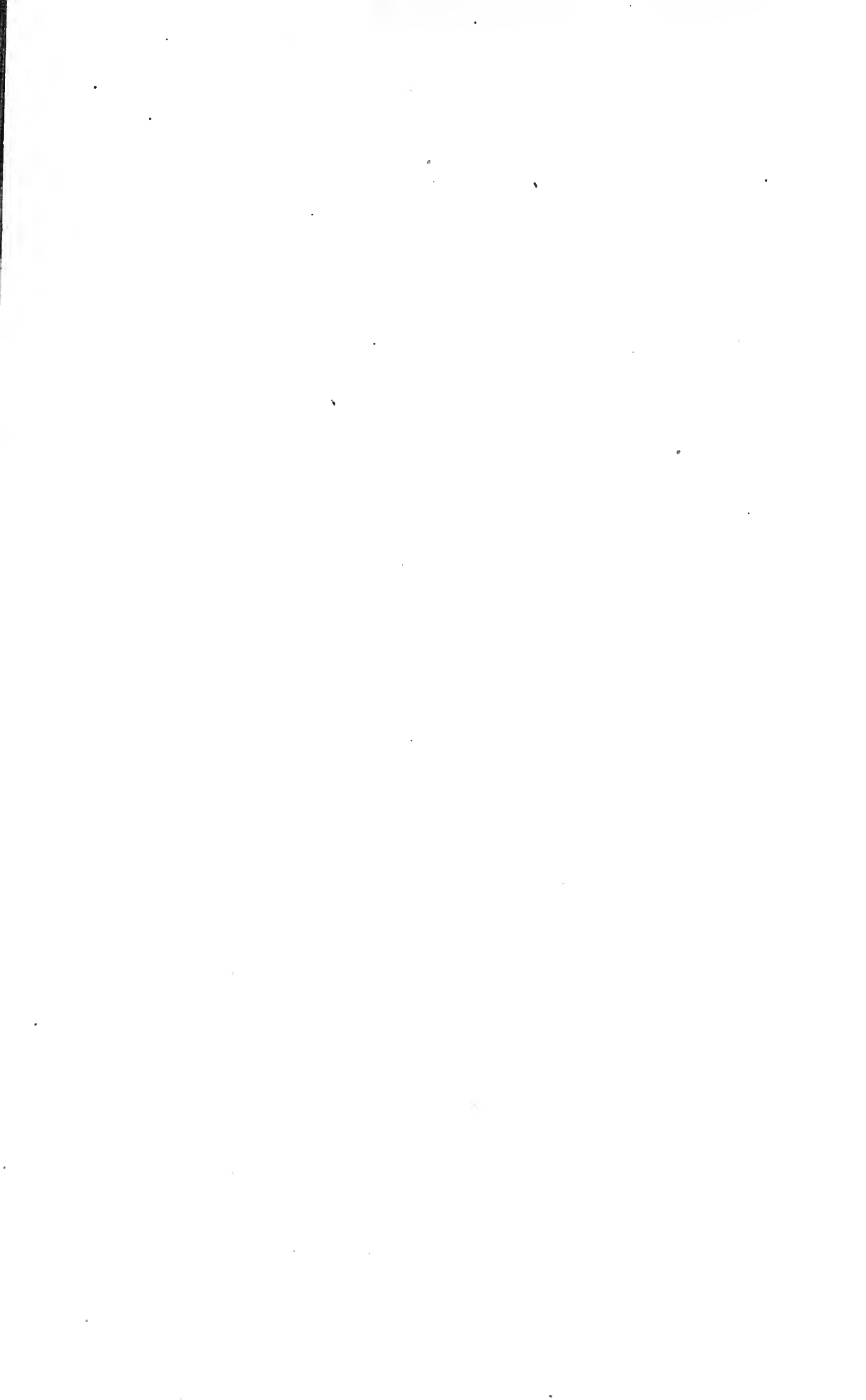



# Equipment for Teaching Domestic Science

*Blue*

By HELEN KINNE ✓

Professor of Domestic Science, Teachers' College, Columbia University



UNIVERSITY OF  
COLUMBIA

WHITCOMB & BARROWS  
BOSTON, MASS., 1911

TX 165  
H 5

Copyright, 1910, by  
TEACHERS COLLEGE, COLUMBIA UNIVERSITY

Copyright, 1911, by  
WHITCOMB & BARROWS

TO VIVI  
ANGELIA

## PREFACE

THE purpose of this book is to discuss the problems that are met in planning a domestic science equipment, to suggest practical solutions that have been worked out through experience, and to give a description of what is done in some of the schools and colleges of this country. As this is not a statistical report, space allows only a few schools and colleges to be mentioned.

Thanks are due to the teachers, superintendents, and supervisors who have kindly given information and whose institutions are mentioned in these pages; to the members of the domestic science staff of Teachers College; and to those students in the Department of Domestic Science at Teachers College who have collected data from year to year. It has not been possible to publish all the information that has been so kindly furnished.

*March, 1909*

*May, 1910*

*September, 1911*

HELEN KINNE

Teachers College





## CONTENTS

CHAPTER	PAGE
I INTRODUCTION . . . . .	I
II THE ROOMS . . . . .	5
III THE COOKING LABORATORY . . . . .	13
IV THE DINING ROOM, LAUNDRY, EQUIPMENT FOR HOME NURSING . . . . .	47
V THE PURCHASE AND CARE OF EQUIPMENT . . . . .	57
VI TOTAL COST OF EQUIPMENT . . . . .	60
VII COST OF MAINTENANCE . . . . .	69
VIII PORTABLE EQUIPMENT FOR LECTURES . . . . .	74
ILLUSTRATIONS OF EQUIPMENT . . . . .	79
INDEX . . . . .	95



# EQUIPMENT FOR TEACHING DOMESTIC SCIENCE

## CHAPTER I

### INTRODUCTION

To the question, what should be the cost of domestic science equipment for school work, the answers are as varied as the conditions where needs are to be met. In the United States and Canada there are in existence equipments of all grades, ranging from those used in the country district or city settlement school to laboratories and appointments not to be surpassed by those in the best equipped university laboratories for work in the natural sciences.

Work in domestic science has been developing for a quarter of a century and many well equipped laboratories are to be found. While economic conditions in the public schools have tended to make the average equipment inexpensive, yet natural pride in a city system or school, in connection with gifts from private donors, has made it possible to equip the workrooms with elaborate and beautiful fittings. Yet such equipment may be no more useful to the school and community than something much plainer. It is difficult, of course, if not impossible, to set a definite standard. The subject, to have dignity, should be well housed; the kitchen and other rooms should be as attractive as possible, and yet no funds should be wasted for mere show or the non-essentials. Work in domestic science is developing now with great rapidity and would be installed in many small towns if the school superintendents could know that an equipment may be serviceable and still comparatively inexpensive. The future growth of this work and its usefulness to the community depend very largely upon the knowledge of what such equipment may

be. What shall be our guiding principles in planning an equipment?

It may be said first that an equipment is adequate which enables the pupils to do their school work with convenience and without loss of time. This means in the cooking room that the room should be sufficiently large for the class, that the sinks, stoves, and tables should be so placed that steps are saved and crowding avoided; that there should be enough utensils, and these selected in relation to the kind of work given. It is unfair to overcrowd a class, and to demand good work where tools are lacking. It is as unjust to both teacher and pupils as it would be to expect a class to learn to write without paper, pen, and ink. On the other hand, too many utensils, especially the smaller, confuse the work and consume unnecessary time in cleansing and keeping in order. Then, too, in this case, pupils miss the opportunity for training in the economic use of their tools, and do not develop ingenuity. A small equipment, well selected, may be much more useful than a large and ill-assorted collection of implements.

In the second place, the equipment should have some practical effect on the community where the school is placed. All articles and utensils should be such as can be used by the children in their own homes, and at the same time offer an incentive to the bettering of home conditions. This latter is true even in the well-to-do community, for, even where funds are not wanting for domestic furnishing, there is often a lack of knowledge as to the best way to adapt means to ends.

A domestic science teacher should be, therefore, a faithful student of mechanical improvements, since the manufacturers in all lines of kitchen furnishings are making changes, sometimes for the better and sometimes otherwise. If, for instance, a wood stove is to be installed, if that is the available fuel in the neighborhood, what is the latest and best pattern? This also holds good with small implements, for new wares and new forms are put on the market almost daily. In the school settlements of the Tennessee mountains may be found striking illustrations of the influence of the school furnishing upon the neighborhood.

The house in which the teachers live, and even the school buildings, are like the mountain cabins, but more convenient and better built. All the changes are of such a nature that they can be copied by those who are building new cabins, or the old can be remodeled by the occupants with little trouble. The same plan is followed in the simple furnishings, where the textiles are made by the mountain women, but with more artistic design and colors than before. The result of this is that many people have taken the hint and have done likewise. In some such way as this, domestic science rooms should be true models, desirable and possible to copy.

In the advanced work of our college departments there is yet another way in which the community may be served. Here is the place for experimenting with new materials and devices, and the passing on to the housekeeper and the lower schools information about better materials and machines.

Then, too, both the school and the college may have an influence in showing that the kitchen and other rooms for the practical work of the house may be made as esthetically pleasing in their own way as the living room. This is sometimes forgotten in domestic science work. One of the best instances of a beautiful kitchen is that in the public school system of Evanston, Illinois. The room in itself is spacious and well lighted, but in addition it has a harmonious color scheme of soft brown, buff, blue, and white. This is carried out in all the details of the room with pleasing effect. Attention to the colors used in walls, floors, and dishes need not of necessity add to the expense.

A knowledge of the needs of the community, therefore, and a well-organized scheme of work are foundational in planning a truly serviceable equipment. The teacher who plans it should be practical, discriminating, and adaptable, not patterning her work entirely on what is done elsewhere, except in so far as that is appropriate to the new locality. In England these matters are under government control; in the board schools the course of lessons and equipment are determined by the government. This would not be possible, nor desirable in this country, since conditions are so varying. Everything depends, then, on the

efficiency and common sense of the teacher and the committee in charge.

This book will treat of what is usually known as domestic science equipment for cookery, table setting and service, house work, laundering, and home nursing. It should be noted that some of the rooms for these purposes may be utilized for work in textiles and in home decoration.

## CHAPTER II

### THE ROOMS

Two situations will be considered: (1) The planning for rooms in a new building, and (2) the refitting of rooms used for other purposes.

1. *The Number.* In elementary-school work it is often possible to devote only one room to domestic science, and this is usually the kitchen. This kitchen, however, can be used for other purposes than cooking. Housework, to an extent, is of course taught in the kitchen. A dining table may also be placed in this room, if no other space is available, and the table setting and service taught here. With a small portable equipment some of the simpler laundering processes may also be conducted. This involves, however, some space where the laundry equipment may be stored when not in use. Where no other room is available, housework may be taught in other parts of the building; sweeping and dusting, for instance, in the classroom, or in the teacher's rooms, if such exist. Lessons in home nursing may be given in the classroom.

In high schools and colleges more than one room is usually allowed. One of the first to provide for is a storeroom for materials and utensils, as a sufficient space for storing provisions makes for greater economy in buying. This room is, if anything, more important than the dining room. Next a dining room may be added; after this a laundry, and then some room, or rooms, where housekeeping may be taught, the conditions being made as much like the home as possible. The need of something of this kind has been felt so strongly that in a number of new buildings, both in Canada and in the United States, a suite of rooms, like a small apartment, has been provided; in other cases a small house has been made available, as at the University of Illinois.

2. *Shape and Size.* For cookery a room that is somewhat longer than it is wide is easy to arrange to advantage and is also of agreeable shape. A long, narrow room is difficult to furnish conveniently and to light well, unless the long side is exposed to the light. A room 24 x 17 feet is of good proportion and is large enough for twenty pupils without extreme crowding. Such a room will allow for two gas stoves, two sinks, but does not leave space for cupboards to extend into the room. Two feet more in each direction is a better size. A room 26 x 38 feet allows for from twenty to twenty-four pupils, with a larger amount of equipment at the sides and better aisle space. There is no room for a dining table in the first room. A dining table could be placed in the last in the center of a rectangular table. A store-room need not be large, but should be amply provided with cupboards. A room 13 x 14 feet will afford good storage space for classes of twenty working continuously.

A dining room 13 x 16 feet will give space for a table seating six or eight guests, leaving room for a small sideboard and space for the waitress to pass. It is indeed economy of space and time to have a dining room that is not too large.

The laundry should afford space for the tubs, dryer, and ironing apparatus unless the washing and ironing are done in separate rooms. A room 40 x 28 feet allows space for steam machinery in addition to other equipment.

When a suite of living rooms is planned, of course the rooms cannot be large. A small apartment in the new School of Household Arts, Teachers College, Columbia University, measures 18 feet 7 inches x 52 feet 6 inches. An apartment at Macdonald College, Quebec, Canada, is larger.

A number of our colleges and universities are now devoting a whole building to Household Economics. These include Domestic Art and Domestic Science and laboratory work in science. Such a building is found at the University of Illinois and one has just been added to the University of Nebraska. The Household Arts Building, Teachers College, is of this type.

In selecting old rooms there is often little choice. The size of the class should be determined upon, and that room, or those



rooms, assigned that fulfill as many of the necessary requirements as possible. This plan was followed in 1908 at the Public School, Tenafly, New Jersey, where a classroom with small adjoining rooms was turned into a cooking room. (See Fig. 46.)

3. *The Location and Exposure.* The top floor of the building is the most desirable if there is an elevator to take up supplies. In the case of the cooking room it is not so much a question of light as of the possibility of better ventilation, if the room is on this story. Odors from the cooking are less liable to penetrate into other rooms of the building. This seems to be equally true whether there is a ventilating system or not. If the basement is well lighted, the cooking room can sometimes be better cut off from the rest of the building for ventilating purposes than if it is in any of the intermediate stories. This question of lighting is, however, a most important one. North light is good for all laboratory work. If the windows are well placed the light is more evenly distributed than where the exposure is southern. Of course, the sunlight adds to the cheerfulness of the room, but window shades should be well adjusted in this case. The question of light is not so important in any of the domestic science work as in the work of the textile and sewing classes; so if there is a choice, the sewing room should have the better light.

4. *Ventilation.* If there is a ventilating system in the building, extra exhaust, with its own special connection, should be provided. Even where the rooms are large and high, the ordinary ventilating system is not equal to removing the products of combustion and the odors, and to keeping down the temperature. If there is no ventilating system some simple device should be used, in order to utilize the windows for ventilation. Of course, windows must be opened wide for airing, but it often happens that currents of air affect oven temperatures and the flames of gas stoves. Boards may be placed under the lower sash of the window, or screens (covered with cheesecloth) may be used, filling the lower sash space. Where there is a flue in the room, the chimney can sometimes be utilized for ventilation by having openings into the flue. If any number of gas stoves are used, there should be hoods above the stoves.

An electric fan gives relief in a crowded and ill-ventilated cooking room. Such a fan may be bought for about \$15.

5. *Windows and Doors.* The windows and doors should be so placed that the wall space is not too much broken. Plain stretches of wall should be planned for cupboards and for blackboards. Good light is obtained if the windows are all on one side of the room, provided they are large, and the room is not too deep. The doors should, of course, open outward.

6. *Chimney and Flues.* The chimney and flues are planned by the architect in relation to other parts of the building. It is

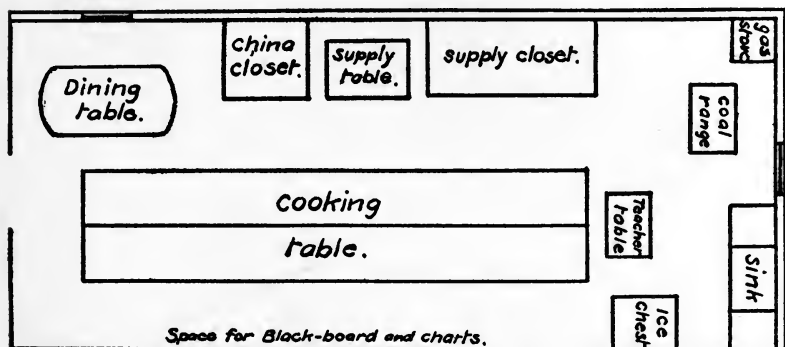

Fig. 1. School kitchen planned for 16 pupils, 15 x 28 feet

necessary, if possible, to see that the chimney is well placed in relation to the other furnishings of the room.

7. *Gas, Water, and Waste Pipes, Steam and Electric Fittings* have also to be planned by the architect in connection with the whole system. The same caution is necessary here as with the chimney and flues.

8. *Wall Finish.* In the cooking room and laundry it is necessary to have the wall finish washable. While this is desirable in the other rooms, it is essential here. The ideal finish is tiling extending from the floor six or seven feet upward. The wall above this tiling may be painted. If the tiling is too costly, the whole wall may be painted, using heavy enamel paint below and cheaper above. While the cost of paint does not differ in different sections of the country, the cost of labor does, and any esti-

mates given here can be approximate only. A still cheaper finish is paint for the first six or seven feet, with a durable wall wash, like Alabastine above. Alabastine is a good grade of calcimine to be bought at furnishing stores and can be easily applied. It does not wash, but can be dusted with a wool wall duster or soft cloth. If an old wall is to be done over, it may be filled and painted, or, if the lower wall is in too bad condition, it may be covered with table oilcloth fastened at the top with a narrow strip of wood. The wall above the strip may be painted or

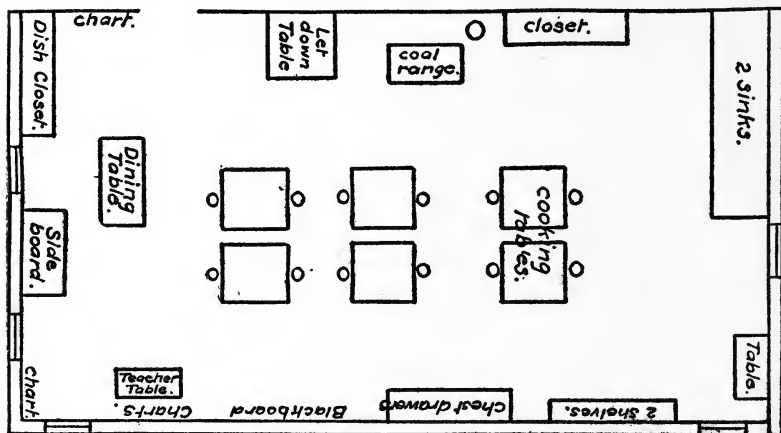

Fig. 2. School kitchen planned for 12 pupils, 20 x 37 feet

washed with Alabastine. In the dining room it is possible to have the wall finish somewhat less expensive. Good colors can be obtained in a wash. The ceilings may be washed with Alabastine or ordinary calcimine. The attractiveness of a room depends largely upon the cleanliness and freshness of its walls, and here it is that the choice of color is important.

9. *Floor.* The question of the laboratory floor is one that is much discussed. For cleanliness, durability, and attractiveness, tiling is the best. It is costly, but of course wears well and may be kept absolutely clean. It is the general opinion in this country, however, that too much fatigue results from the use of the tiled floor for laboratory work. A good hard wood is con-

sidered the most desirable. Maple is one of the best, though yellow Georgia pine is also excellent. A combination of tiling and wood works well, the tiling being placed under the sinks and under the stoves, in the former case for cleanliness, in the second for cleanliness and also for proof against fire. It is difficult to have the tiles run into the woodwork without a crack, if the wood

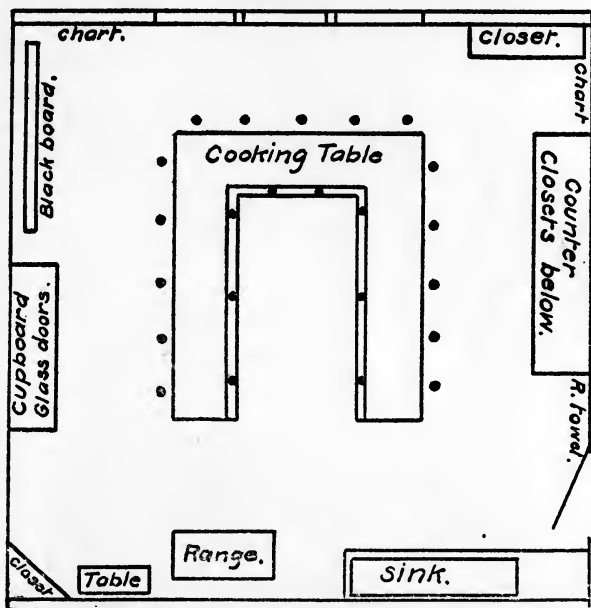

Fig. 3. School kitchen planned for 15 pupils, 24 x 24 feet

shrinks; but if a crack occurs this can be filled in. Terraza and cement floors always crack and are not desirable. The objection always to the wood floor is the labor involved in keeping it in order from day to day. A good method is to rub the floor occasionally with oil, washing the floor between the oilings, or using some mixture of oil and wax. At Drexel Institute, Pennsylvania, the floors are stained, waxed and rubbed, brushed with a soft brush and dust cloth; they are never oiled or washed. Such a floor is, of course, somewhat slippery, which might be objectionable in a laboratory for children. Where the floor is

not new, it may be scraped, planed, and stained, and then treated with oil or wax. In such a case linoleum is an excellent floor covering. The best cloth should be selected, of the inlaid variety, not painted on the surface as in the cheaper grades. This covering is pleasant to the foot and is kept clean with no great difficulty. If the floor underneath is at all rough or uneven, this should be remedied before the linoleum is laid. Pains must be taken to fasten the linoleum well down at the edges. It is best

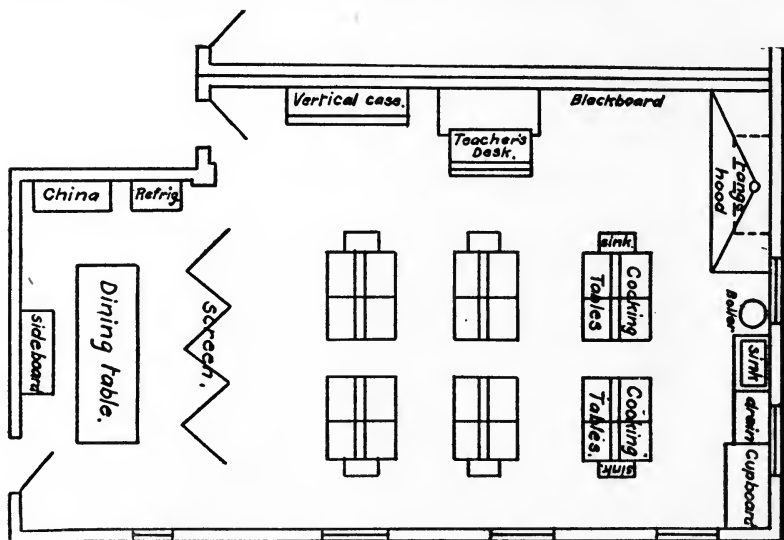

Fig. 4. School kitchen planned for 24 pupils, 24 x 41 feet

to allow it to stretch for a time before this is done. Cement is sometimes used to fill the space between the linoleum and the wall. This is not an inexpensive covering, since a good linoleum costs \$1.50 a square yard, and it is not worth while to have the cheaper grade. It is, however, durable, lasting for many years.

10. *Woodwork* should be as plain as possible and without cracks or seams or elaborate mouldings. Plain wood finish can be easily cared for. Well-painted wood also gives a surface that is easily kept clean, and if made to harmonize with the color of the wall, gives a pleasing effect.

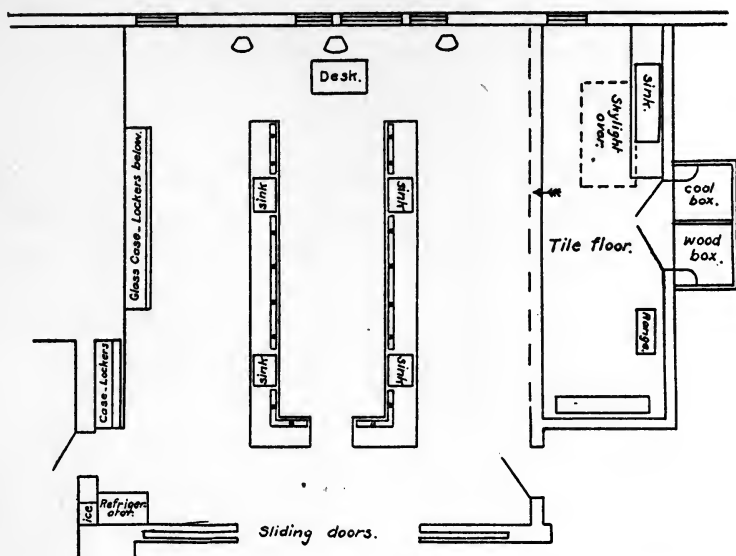

Fig. 5. School kitchen planned for 16 pupils, 27 x 34 feet

#### COST OF WALL FINISH AND LABOR

(NEW YORK CITY, JANUARY, 1909)

Calcimine, per sq. yd., 1 to 3 coats.....	about \$0.40
Paint, per sq. yd., 1 coat.....	.30
Table oilcloth, per yd., 1½ yd. wide.....	.30
Tiling, glazed, per sq. ft.....	.60-.75

#### COST OF FLOORING WITH LABOR

Scraping and staining old floor, 1 coat varnish.....	per sq. yd. \$1.00
Paint, as above .....	" " " 1.00
Linoleum .....	" " " 1.50
Vitrified tiling.....	per sq. ft. .40-.60
Maple flooring .....	" " " .32
Yellow pine flooring .....	" " " -.35

Figures 1 to 7, inclusive, show kitchens of varying shapes. Figure 8 is the floor plan of the small apartment, School of Household Arts, Teachers College.

Figure 9 is the plan of a whole department.

## CHAPTER III

### THE COOKING LABORATORY

POINTS for special study in addition to those already treated are the work tables, stoves, sinks, cupboards and lockers, seats,

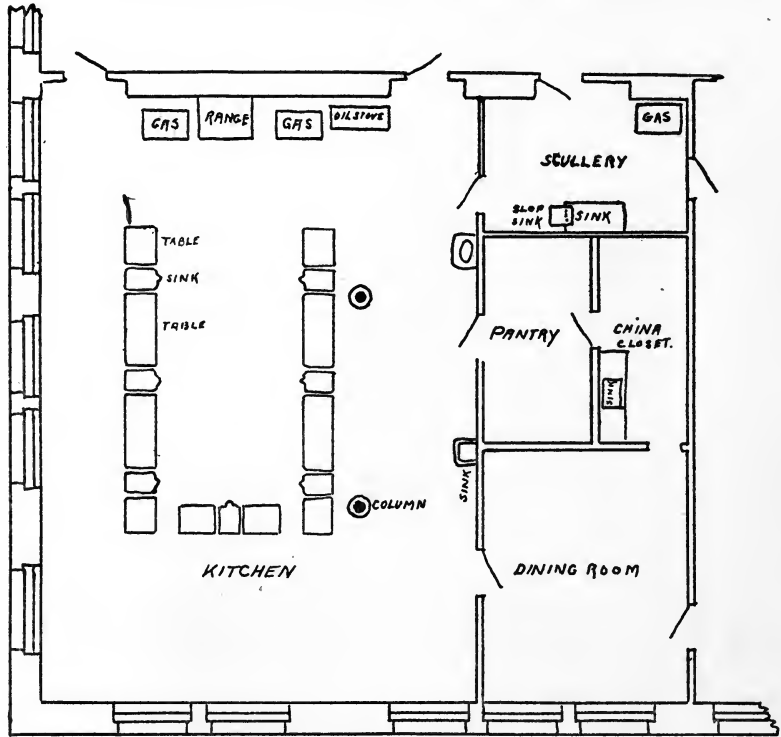
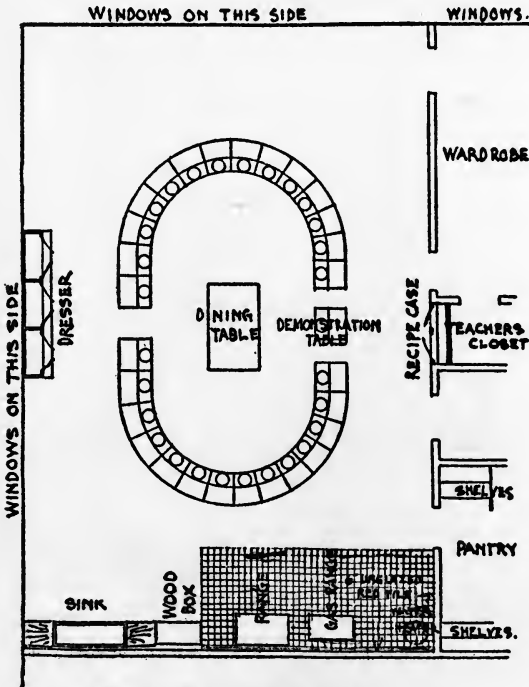
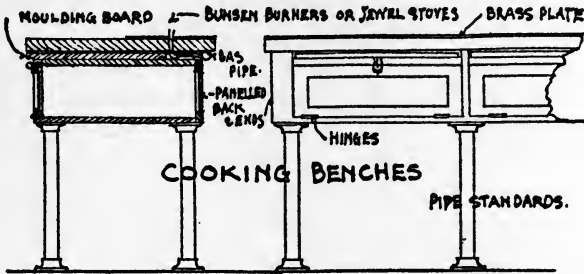

Fig. 6. School kitchen, Mechanics Institute, Rochester, N. Y.

refrigerator, and utensils. It is especially important here to study the placing of all these fittings in relation to one another, that all may be easily accessible without many steps for either teacher or pupils.

I. WORK TABLES

There must be enough table space to allow each pupil room for work. In our public schools, classes must be large; twenty



PLAN OF COOKING ROOM.

Fig. 7. Plan of cooking room fittings, Public Elementary School, Boston, Mass.



is a good number for one teacher to handle, though twenty-four is possible. Above this it requires much skill in the teacher to handle her class, and both teacher and pupils work at a disadvantage. The general practice in this country is to provide for individual work, or for work in small groups. The idea that the school kitchen should be as much like the home as possible

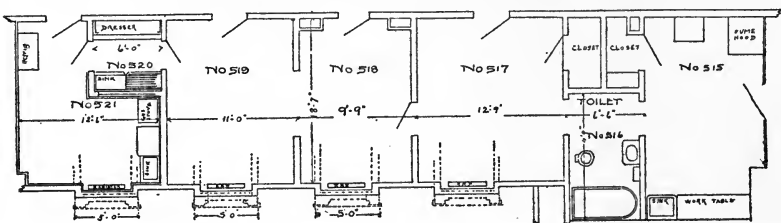

Fig. 8. Floor plan of apartment, School of Household Arts, Teachers College, Columbia University

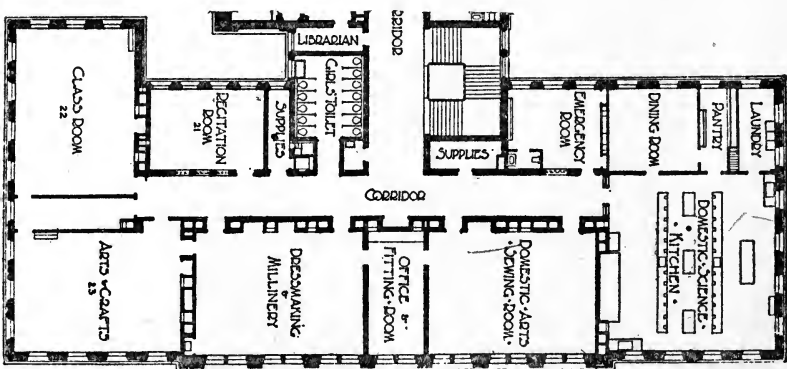

Fig. 9. Rooms for domestic arts and science in High School, Newton, Mass.

is, in some cases, responsible for an equipment that does not allow for individual activity. Home conditions cannot be duplicated in regard to table space, because twenty children cannot work well at a table large enough for only one or two. If the room is small and table space small, the class must number less than twenty. A work table to be convenient must also be so arranged that no floor room is wasted. Here the strength of the

teacher may be saved, if an arrangement is possible that enables her to see easily all the members of the class at work.

A variety of floor plans is possible, and there is a wide range of selection in form and material, with a corresponding variation in cost.

Tables may be either movable or fixed.

*a. Movable Tables.* The movable table is advisable where strict economy is necessary. Stained packing boxes, or common wooden kitchen tables, either old or new, or wooden horses with movable boards on top, have been used successfully; and in some instances, as in the district schools of Canada, boards are placed on top of the desks in the classroom. In one school in the United States where only \$100 could be appropriated for equipment, the instructor secured library tables that were no longer in use, her pupils assisting her in scraping the tops and coating them with white enamel paint. The domestic science classes in this school numbered only twelve or fifteen, and ample working space was thus afforded at the cost of the painting. Such simple arrangements are desirable in introducing the work in schools where funds are limited, or in city settlement schools.

The stained packing box (see Fig. 40), dimensions 24 x 24 x 3½ inches; cost of stain and shelf, 50 cents; zinc top, 50 cents; total, \$1.00.

Kitchen tables cost: without drawer, dimensions 3 x 2 feet, \$1.89; with drawer, dimensions 3 x 2 feet, \$2.80; without drawer, dimensions 3½ x 2¾ feet, \$2.31; with drawer, dimensions 3½ x 2¾ feet, \$3.29; with zinc top, dimensions 3 x 2 feet, without drawer, \$4.35.

If the top of the kitchen table is of soft wood, this involves much scrubbing, and stains cannot always be removed. Some form of mat should be supplied in order to protect the table from the heat of a hot utensil. A good varnish, like spar varnish, fills the wood and makes it easier to keep the table clean. The varnish is, of course, easily marred by heat and needs to be renewed from time to time.

The legs of the table are more easily kept clean if they are painted with enamel paint or coated with shellac, and the cost is very slight.

The kitchen tables can be arranged in any of the ways suggested for the fixed tables, and gas piping can be connected with them and an individual gas stove used as with the fixed table. The cost for a class of twenty, two at a table, using tables  $3\frac{1}{2}$  x  $2\frac{3}{4}$  feet, would be \$18.90.

*b. Fixed Tables.* These may easily be made very costly; but tables may be built in by a local carpenter at comparatively small expense. It is better to have them, when possible, than the kitchen tables, because one is free to select the proper dimensions, and a better material can be used for the tops. The supports of the table

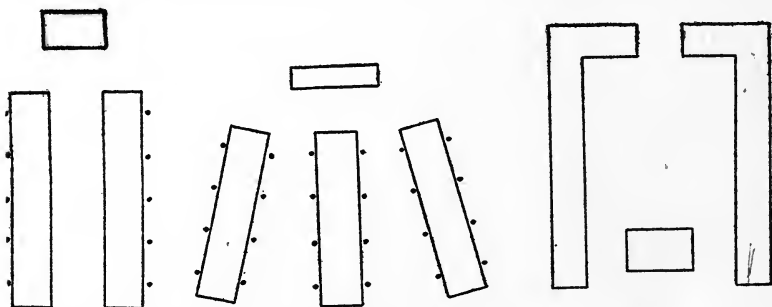

Fig. 10. Parallel

Fig. 11. Slanted

Fig. 12. Hollow Square

are sometimes made of metal, either iron piping or solid iron, enameled or nickerled.

A new table is on the market where the top only is of wood, the lower part, including drawers and cupboards, being made of steel. This is expensive, and so far has been used only in diet kitchens. In places where both lumber and labor are high, it would be well to submit a design and obtain an estimate from some firm that manufactures school tables. This is supposed to reduce the cost.

A ready-made table has been put on the market by a Western firm. It is designed for two pupils standing side by side; has a drawer; a top of some composition; two gas stoves or hot plates of the bracket pattern. The cost is about \$20.

1. *Parallel Tables.* (Fig. 10.) These are convenient in a long and narrow room, and also in a room where serving is to be

done as well as cooking; the cooking in such a case may be carried on in one part of the room and the serving in the other. A similar plan is used in Drexel Institute, Philadelphia, where two parallel tables are placed at one end of the room, leaving good space at the other end for sinks, stoves, and other fittings. (See Fig. 51.) This is not a good arrangement, except in somewhat small classes, say from ten to sixteen; but it is convenient for the teacher, who can pass down easily between the two tables.

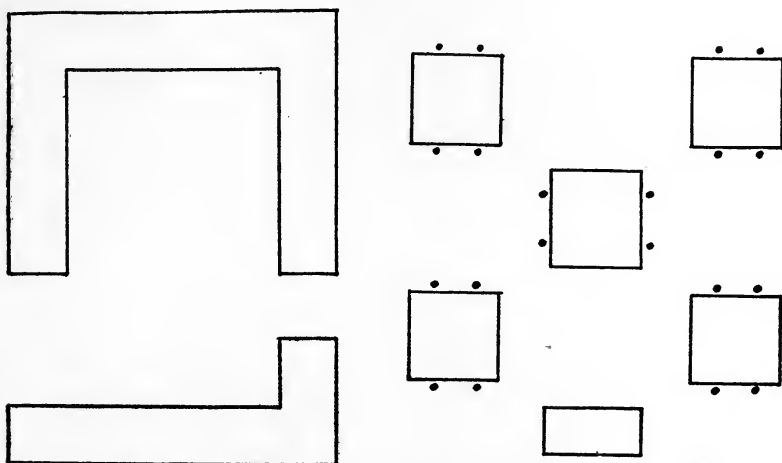

Fig. 13. Hollow square with openings adapted to a particular room;  
Fig. 14. Group tables

2. *Double Parallel Tables.* This is an excellent arrangement for economizing floor space, but it is a difficult one for the instructor, since she must sometimes pass rapidly from one section to another; and it is a very poor arrangement for young pupils. Then, too, the gas piping for individual stoves must come up through the center of the table. There is no difficulty in this unless a gas leak occurs, when the leak is very difficult to repair.

3. *Slanted Tables.* (Fig. 11.) This is a plan that obviates somewhat the difficulty in the parallel tables. Here twenty-four pupils may easily be accommodated in a comparatively small space, and the teacher standing at one end can easily look down the three

tables and see where help is needed. This has been used successfully in a public-school kitchen.

4. *The Rectangular or Hollow Square.* (Fig. 12.) If space is available, this is by far the best table arrangement for all school work, and some instructors prefer it for college work. This arrangement may be varied in the floor plan to suit the shape of the room. The figure given illustrates a form wide open at one end. The table may be made to accommodate a larger number of pupils by having a small opening at both ends. Fig. 13 shows the

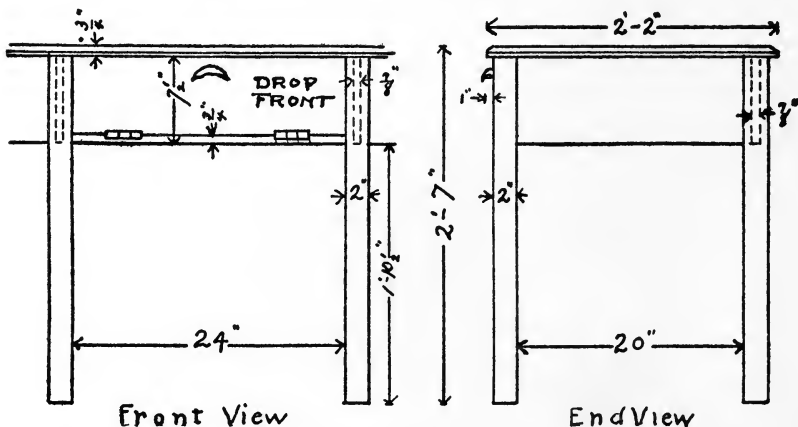

Fig. 15. Table with open shelves only, or shelves with drop front

same form with irregular openings adapted to a particular room. There should always be two openings in the table. The great advantage of this arrangement, in general, is that the instructor is able to observe her class easily and pass from one pupil to another without any loss of time.

5. *Group Tables.* (Fig. 14.) Group tables economize space and allow the pupils to pass back and forth through the room with freedom. The objection is the same as in the case of the double parallel; that is, the teacher cannot see all the pupils at the same time. This plan is not a good one for elementary-school work; it may be used in secondary-school work, although it is better still for maturer students.

6. *Single Tables in Rows.* The single table gives each pupil individual freedom and a condition more like that in the home kitchen. This arrangement is in use at the Carnegie Technical School, Pittsburgh, and at the School of Household Arts, Teachers College. In the latter school the tables are placed back to back, with a row of stoves between the rows of tables. Single tables may also be arranged in a rectangular form. This plan is too costly, on the whole, for school work, since the labor involved in making is more than that in building a continuous table. It is an excellent plan, however, for advanced students.

7. *Dimensions.* The dimensions are of great importance. Much fatigue is avoided by having a high table for adults. A wide table makes work difficult for elementary pupils. Height: minimum, 31 inches for children; maximum, 32 to 34 inches for adults. Depth: minimum, 20 inches for children; maximum, 24 inches for adults. The 20-inch depth is rather narrow, except for young children. Any depth beyond 24 inches is not generally useful, especially as the reach is too long if the individual gas stoves are placed at the back of the table. Width for each pupil: minimum, 24 inches; maximum, as much as the size of the room and the funds will allow; 30 inches, however, allows good working space. Twenty-four inches can be used only with children, and even then it is a little crowded. This space, however, will serve.

8. *Designs for Shelves, Drawers, and Cupboards.* It is these table attachments that add materially to the cost of the table, not so much in material as in the labor involved in construction. They do add, however, to the utility of the table, and save much time and labor in the carrying about of utensils and materials. For school work the simplest design is on the whole the best. Elaborate arrangements make the care of the table more difficult besides adding to the cost of making. Tables with a drawer below are adequate and much more convenient on the whole than those tables that have the cupboard below. It is difficult to reach the cupboard to keep it in order and to keep it clean.

a. The simplest attachment is a shelf placed beneath the table top at a distance of 6 or  $6\frac{3}{4}$  inches and open on all sides. (Fig. 15.) The chief recommendation for this plan is its cheapness.

Small utensils can, of course, be kept on this shelf, but in order to take them out or put them away the pupils have either to bend or kneel, and the utensils are difficult to reach; then, too, the shelf is open to the dust. This plan, however, is in use in some of our public-school kitchens, and in one, at least, of the technical training schools. (See Drexel Institute Kitchen, Fig. 51.)

b. Inclosed shelf with drop front. (Fig. 15.) This plan costs more, but the dust is kept out.

c. A single drawer of the depth indicated, with partitions, will hold all the small utensils necessary and make them more

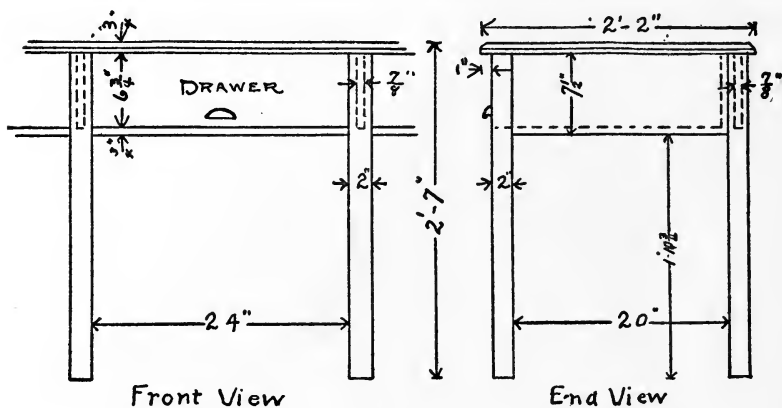

Fig. 16. Table with one drawer

available than they are with the shelf, or drop front. (Fig. 16.) It is true that it is not easy to keep the drawer clean. The pupils are apt to leave the drawer open a crack, and flour and crumbs easily fall in. This objection can be partly overcome by having the table top project at least one inch beyond the front of the drawer, and also by training the pupils to close the drawer.

The drawers should be subdivided with movable partitions, in order that the small utensils may be kept well in order. The partitions may be made of thin wood, to move in slots, such as are found in desk drawers. Usually two partitions are used, but at the Lillian Massey School, University of Toronto, a drawer with many partitions, allowing not more than one article in each space,

proves very convenient. White table oilcloth is recommended for the bottom of the drawer, although some teachers prefer to have plain shellac, which can be renewed from time to time, or enamel paint.

*d.* A cupboard below with drawers either for utensils, or for utensils and provisions. (Figs. 17 and 18.)

The arrangement indicated in the plate gives room for a sufficient number of utensils for advanced work. The drawers are

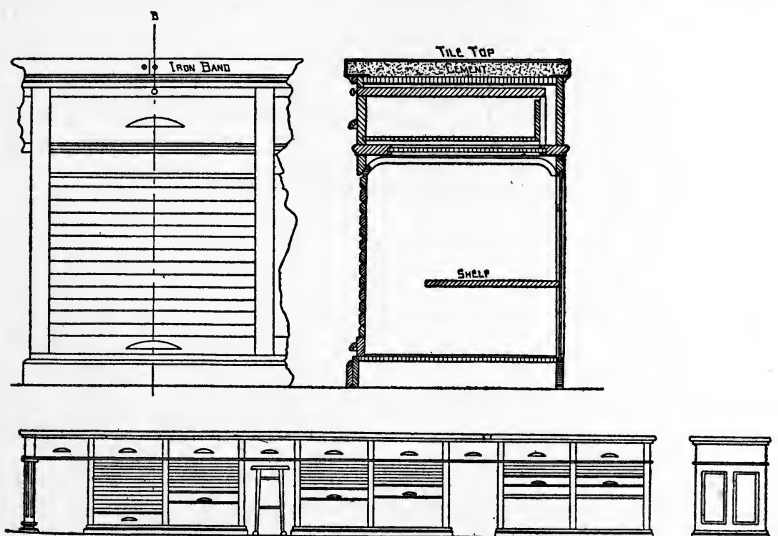

Fig. 17. Table with drawers and cupboards underneath

arranged as in Fig. 18. The provision drawer holds sugar, flour, salt, pepper, and the common spices. This plan saves labor and time in carrying about these provisions. The roll front does away with the inconvenient door and costs very little more than the door. The disadvantage of this low cupboard is that the utensils are difficult to reach. This model is expensive.

*e.* Drawers and cupboards below and above. (Fig. 19.)

*f.* Shelves above and drawers and cupboards below. (Fig. 20.)

These two models can be used only where the individual stove is not to stand on the top. They are the designs of the tables used



at Teachers College in the School of Household Arts. In Fig. 19 the cupboards are placed above at a convenient height in order that they may be easily reached. The bottom of the cupboard is high enough above the top of the table to make all of the top available. In Fig. 19 the stove is entirely separate from the table.

Fig. 20 shows another arrangement with most of the cupboard and drawer space below, with only one shelf above, where books

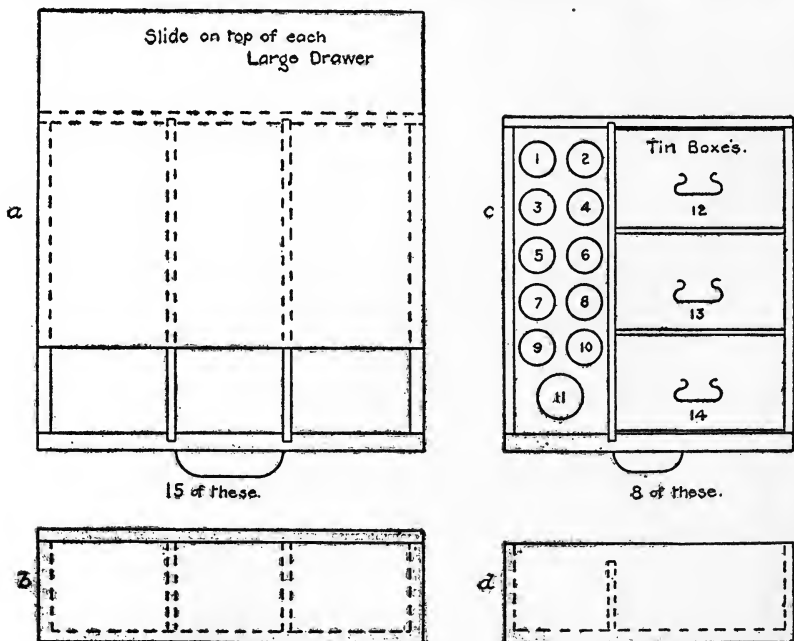

Fig. 18. Details of the same table as in Fig. 17

and other articles may be placed. The stove is attached to the side of the table, with a slate back, thus having the stove top level with the table top.

These designs may be used in any of the floor plans indicated, yet certain combinations are better than others. The design with shelf only would not be good form for a group table arrangement. The drop front, or single drawer, may be used with any of the floor plans. Fig. 17, if used in one of the continuous plans, gives

space for stools underneath. Other designs for both the continuous and the group table may be found in the different illustrations in this pamphlet.

9. *Other Table Attachments.* Where the group table or single table is used, a small, swinging towel rack of wood or nickel may be attached to the side. Hooks for dish pans may be screwed into the side of the table, or, in case of the continuous table, placed on the inside. Space for a moulding board may be allowed under the table top and above the drawer; care should be taken, however, to see always that the moulding board is dry before it is slipped into place. A less expensive arrangement is to buy a small moulding

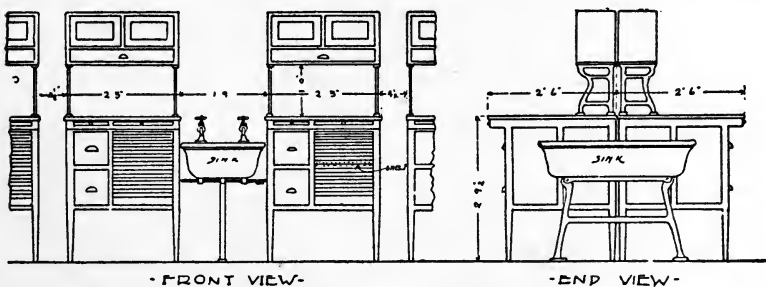

Fig. 19. Drawers and cupboards below and above the table top

board and hang it on the end of a single or group table, or underneath a continuous table at right angles to the length of the table between the drawers.

10. *Materials.* The table top and other parts of the table must be considered separately, since a cheaper material may be used below, while the top must be of good quality. The top should be easy to clean, non-absorbent, fireproof, if possible, durable and not resonant. It is impossible to find any one material that combines all these qualities. Wood is cheaper than any form of the fireproof materials, and must be used for this reason in many places. The wood should always be protected by some kind of mat, say zinc, metal-lined. Hard woods are desirable, and of these maple is the best. It has a hard, close grain, a good color, and better wearing qualities than oak. Of the fireproof tops in

use, slate is one of the cheaper, but it is unattractive in color and absorbs grease. Marble comes next in the scale of cost, but it stains and shows scratches. Glass and vitrified tiling are about the same in price, but so far as it has been tried glass has not proved satisfactory. A number of kinds have been in use, and if information is correct, in every case the glass has finally cracked with heat. Where the stove is not placed on the table top, the new opaque glass is an ideal material; the surface is entirely non-absorbent; it is smooth, easily cleansed, and does not crack when an ordinary weight is dropped upon it. Vitrified tiling is non-

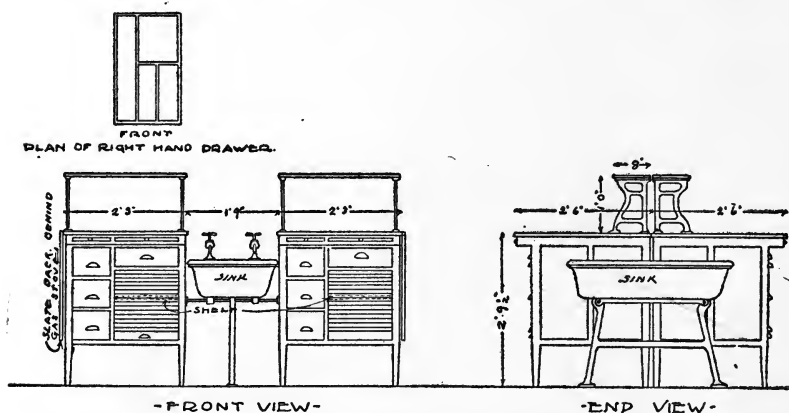

Fig. 20. One shelf above, drawers and cupboards below top of table

absorbent, has a good color, cleanses easily, and has no surface glazing to crackle with the heat. If well laid there is no warping of the top. The one objection is that the cement wears out by degrees and dirt collects. The vitrified tiling comes in either the hexagonal or the square form, and gives most satisfactory and desirable tops. An attempt has been made to have this tiling moulded in large sections, but in the baking these sections warp.

There are a number of compositions on the market that are sometimes recommended for table tops. One of these is known as alberene. One or two teachers have reported this top as not satisfactory in regard to durability. With most of these compositions, there is cracking, and they are absorptive. Another material is

known as white enameled lava. This is in use at the Carnegie Food Laboratory, Boston, Mass. This material is said to bear heat well and to be non-absorptive. It is, however, very costly.

#### COST OF TABLE TOPS

Maple, without labor.....	per sq. ft.	\$0.075
Vitrified tiling, with labor.....	" " "	.40-.60
Opaque glass, Novus 24 x 24 in. ....		6.75

#### COST OF TABLES

(PRICES QUOTED NEW YORK CITY, DECEMBER, 1909)

Fig. 16, single drawer, maple top, ash below, 20 pupils.....	\$100.00
Fig. 17, vitrified tile top held with nickel-plated bars, quartered oak below, 20 pupils.....	725.00
Fig. 17, vitrified tile top held with nickel-plated bars, ash below, \$50 less than above.	
Fig. 17, maple top, ash below.....	500.00
Fig. 19, drawers and cupboards, oak, top of Carrara glass, nickel-plated supports, each pupil.....	78.00
Fig. 20, same material as the one above, each table.....	43.00

## II. SEATS

It is necessary to provide seats of some kind, even if little time is given in the cooking laboratory to recitation. If the cooking room is large, the best arrangement is to place two or three rows of seats or chairs at the end of the room near the blackboard. This enables the teacher to gather her class for a short time for discussion or note taking. It is seldom, however, that space permits this arrangement. If not, stools should be provided or some kind of seat attached to the working table.

I. *Stools.* This is the most inexpensive form of seat, if a plain wood top stool is furnished. A stool should be selected with legs that spread as little as possible; the height depends upon the height of the table. Children should be given a lower stool than adults. It is convenient to have a stool low enough to push underneath the table. This is possible if the table has a shelf or one drawer underneath. Stools are always more or less in the way of the pupils when they are at work, therefore they should be pushed either

back against the wall or under the table. The legs should be tipped with rubber in order to avoid noise when they are moved. A more comfortable stool has a cane seat. A back is sometimes attached, but the stools are used so little that the back is not really necessary and adds to the expense. Stools may be purchased at almost any furniture dealer's, and reduced rates are given by the dozen.

2. *Attached Seats.* There are two kinds:

a. A seat that pulls out from underneath the drawer of a table. This is the cheapest of the attached seats. It should be planned when the design is made, and built in by the carpenter. It may

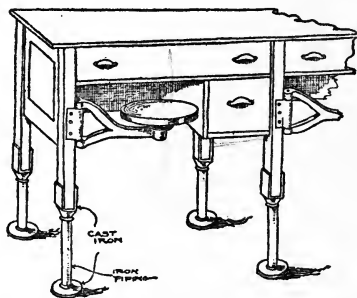

Fig. 21. Section of continuous table, with place for swinging seat

be used with either the continuous or the group table where the space below the drawer is not filled up with a cupboard. It may easily be pushed back when not wanted and is therefore convenient; care should be taken to have it made sufficiently strong. Its great disadvantage is its discomfort, owing to the cramped position that it necessitates. It can be used only for a short space of time.

b. A wooden seat with an iron bracket may be attached to the side of a table arranged according to the group plan; and with some designs, on a continuous table. (See Fig. 21.) The bracket may be hinged to swing sideways and the seat may be made to turn down. There is a variety of these seats on the market, which may be obtained from some of the large stool or store furniture companies. They cost less when purchased by the dozen.

Prices are: plain wooden stool, 17 inches height x 13 inches diameter, 50 cents; cane seat stool, 21½ inches height x 13¾ inches diameter, \$1.50; wooden seat with iron bracket (Fig. 23), about \$2.00.

### III. STOVES

The kind of stove selected depends upon the fuel or fuels that are used in the neighborhood of the school. The grade and pattern depend upon the resources of the school and the home conditions of the pupils. In the public schools of our large cities it is well to have both coal and gas, since both of these fuels are in common use. In cities where the gas rate is reasonable and the nickel in the slot system is used, the use of gas is increasing. In smaller towns coal is apt to be the ordinary fuel, except in natural gas regions. In some rural districts wood is still in use. The use of kerosene, however, is very common in small towns and in rural districts, and in such cases there should be a good kerosene stove. There is no reason why the use of the small kerosene stove and some form of the fireless cooker should not be taught in the city schools, since they make for economy and for comfort in the summer to the city dweller. A useful lesson to a public school would be the making of the fireless cooker, which may be done at so little expense and which is really so valuable.

A fireless cooker for school use is made in a large wooden pail, with three cushions, one for the top and one for the bottom, and a long one which will fit the inner circumference of the pail. In this space a granite kettle to fit should be placed. The cushions should be covered with denim and filled with either excelsior or hay or sawdust. A fireless cooker may be even cheaper than this one; but if an inferior pail is used it is apt to leak, and if the outer box is not well made it is, of course, not air-tight. An old wash boiler or a wooden packing box may be used in place of the wooden pail, if in good condition, or an old trunk.

In laboratories for research work, and those where teachers are trained, as many types of stoves should be furnished as possible—coal, gas, kerosene, electric attachments, denatured alcohol stoves, the Atkinson cooker, and the fireless cookers.

Two sizes of stoves need to be supplied: the large stove, usually placed at the side of the room, and the individual stove placed upon the work table, one for each pupil.<sup>1</sup> For a class of twenty children doing individual work, two stoves of ordinary size should be provided in order to afford space for baking, or one gas stove and one coal stove. Sometimes portable ovens are used, placed upon the individual stoves, but these are not altogether satisfactory.

A gas stove of some well-known make should be selected, care being taken to see that the burners have drilled holes, and that burners and tops are so arranged as to be easily cleansed. The oven should be double, the oven burner giving a good blue flame. A gas stove that has the oven above is easier for an adult to use than the ordinary form with the oven below; the stoves with the oven below the top are, however, less expensive.

The coal stove need not be large nor expensive for school use; indeed, it is better to have a small portable range, easily managed by the pupils, than a large and expensive one. A range with six holes, a good oven and damper arrangements, and removable tops can be bought at a reasonable price. Large ranges, costing from \$70 upward, are not serviceable except in diet kitchens or lunch rooms, where a large amount of food is to be cooked. A stove plain in construction and finish should be selected, if possible, rather than those designs with absurdly elaborate decoration.

#### PRICE LIST OF STOVES AND HOODS

Gas stove, 4 burners, with broiler and oven.....	\$18.50
Gas stove, same dimensions as above, oven above.....	25.20
Small portable coal range, 6 holes, good oven and drafts, removable tops .....	14.00-15.00
Coal range, 8 holes, 2 ovens, shelf for dishes, water back, revolving and sifting grate, top of oven plastered to be non-conducting, about .....	30.00
Large coal range of steel, or the French range.....	70.00
Hood, about .....	10.00
Electric oven, dimensions 17 x 13 x 12 in. (inside).....	30.00-40.00

<sup>1</sup>In the German Housekeeping Schools the stoves stand in the center of the room, or free from the wall.

Blue flame kerosene stove, 2 burners, portable oven.....	\$10.00-15.00
Aladdin oven on stand, lamp underneath.....	30.00
The commercial fireless cookers.....	3.50-30.00
Homemade fireless cookers.....	1.00-2.00

*Individual Stoves.* The purpose of these small stoves is to allow for individual work. The argument that they are not practical, because different from the stoves used at home, is answered by the fact that the use of the small stove, either gas or kerosene, is common in both city and country homes. In city schools the small stoves are always gas stoves, but kerosene may be used

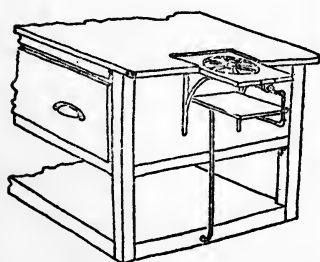

Fig. 22

Table with stove at side

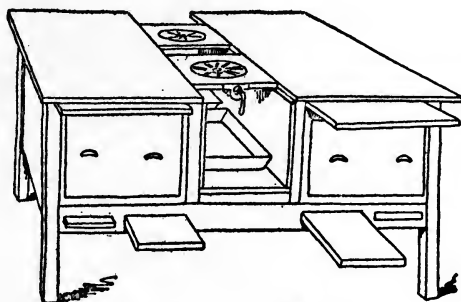

Fig. 23

Table with stove in center

Manual Training High School, Toledo, Ohio

when gas is not available. The blue flame kerosene stove is better than the yellow flame, although it is more expensive.

Electric plates are, as yet, too costly for general use. For instance, one, 7 inches in diameter, cost \$8.25 (net) in 1907.

As yet denatured alcohol stoves are expensive. In the course of a few years we shall probably have stoves of a type which will be most useful for individual school work.

#### a. *The Single Gas Stove.*

The most economical plan is to buy one of the small gas stoves on the market. Many good stoves may now be found at house furnishing shops, or they can be bought directly from the manufacturer. A gas stove for this purpose should stand high enough



from the table to allow the table to be cleansed easily; the top should be large enough to hold a good-sized utensil well, and as flat as possible, in order that the utensil may not tilt. The legs of the stove should not spread too much. The burner should be of a form easy to be cleansed. Several makes have a removable burner that may be easily washed. A nickel-plated stove is easily kept clean, although it discolors from continuous use.

These stoves may be attached by rubber tubing to a gas pipe that runs along the back of a continuous table, or may be connected by gas piping. In group tables gas piping may be run through

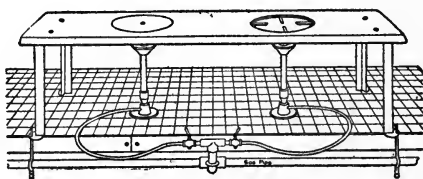

Fig. 24. Hot plate No. 1, used at Teachers College

the table and the small stove attached to that. The rubber tubing should be of the kind used in a chemical laboratory. The advantage of the rubber tubing is that the stove may be easily moved when the table is to be scrubbed, and it also allows the stove to be pulled forward, if necessary, toward the front of the table. It has to be renewed from time to time, and should be carefully wired on to the stove to prevent slipping off. Gas pipe makes the stove steadier, but of course the stove cannot be moved. A hinged joint was tried in one school, which allowed the stove to be turned upward while the table was being cleaned; the plan was not thought to be successful, because leakage frequently occurred at the joints.

A number of special patterns have been devised, made to order, and used with success.

Hot Plate No. 1, used at Teachers College, Columbia University. (Figs. 24 and 31.) This plate has a cast-iron top with two holes, and a cover on each. The supports have holes at the base which slip over nickel-plated pins fastened on the back of the table.

A Bunsen burner with a rose top is used for each hole. Care should be taken in selecting a Bunsen burner to see that the diameter of the top is not too wide, for the flames should not extend beyond the edge of the hole in the hot plate. The Bunsen burners may be attached by rubber tubing, or by iron piping so joined that the stopcock is at the side of the hot plate. The advantage of this plate is that it allows room for two utensils

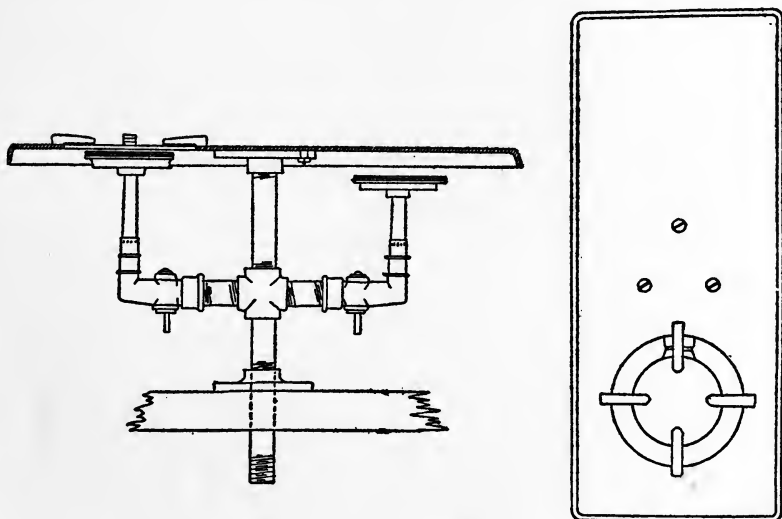

Fig. 25. Hot plate No. 2, used at Hartford High School

with the full gas flame underneath, and also with covers and the gas turned low will allow cooking at a low temperature. The heat is evenly distributed throughout the plate, and thus the plate is more like the top of an ordinary stove. If held by pins and not screwed to the table, it is easily taken off to be cleaned and also for the cleansing of the table. Its one disadvantage is that it radiates a great amount of heat.

A better design for this hot plate would probably be an attachment by a bracket of the right-angled variety fastened to the back of the table. This would leave the table space entirely free. This latter plan would be possible only on a continuous or single table.

Hot Plate No. 2. (Fig. 25.) This is a modification of No. 1. It was designed for the Hartford High School by Mr. Charles Howe. The gas piping comes up through the table and forms a support for the plate itself, as well as for the Bunsen burners. This leaves the tables free, and it is considered by those who have used it to be a most convenient form of the hot plate.

Hot Plate No. 3. (Fig. 49.) This is in use at the Technical High School, Cleveland, Ohio. It has no covers. This plate has a removable, slightly raised grate above the burner, and also a cup which hangs in the opening and surrounds the burner, protecting the wood table from the heat. The cup is also removable for cleansing. This makes it unnecessary to have the woodwork of the table protected.

One objection to the individual stove placed on the table top is that the height is inconvenient when a utensil is placed on the stove. This difficulty may be obviated in a table of the group type by sinking the stove in an open space at the center of the table, thus having the stove top level with the table top. (Fig. 23.) Another arrangement which has the same result is to attach the stove to the side of the table. This has been done in one cooking room at the Manual Training High School, Toledo, Ohio. (Fig. 22.) This device has been adopted in one of the laboratories of the School of Household Arts, Teachers College, Columbia University. A stove with an oven underneath is attached to the table. (Fig. 20.) The table is protected from the heat of the stove by slate.

*b. Continuous Rack, Bunsen Burners.*

This style of stove is considered convenient by some teachers. The stand itself is a permanent fixture in connection with the table, is therefore steady, and leaves clear table space when the gas pipe runs on the back of the table or comes up through the table. Bunsen burners are used underneath the stove and are attached as already indicated. Most of the designs are easily cleansed. This arrangement is not inexpensive, since the work must be done to order and special work is costly nowadays. In any case, with this type of stove it would be necessary to submit the design to a local plumber for an estimate.

Rack No. 1. In this design the supports are of iron piping, the top being made of heavy wire gauze; strong supports are fastened

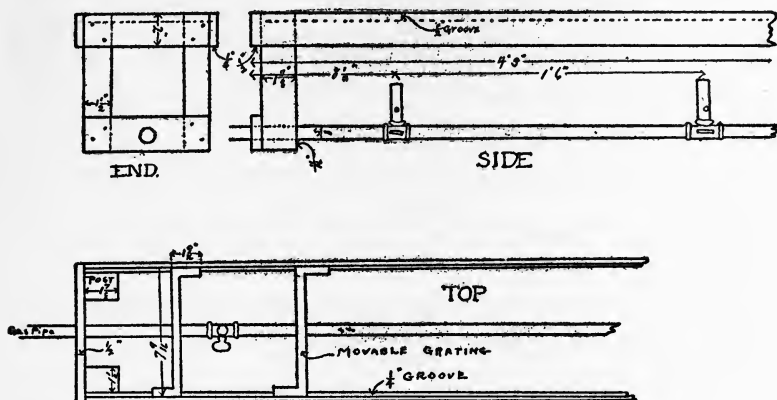

Fig. 26. Continuous stand, Bunsen burners, Simmons College, Boston, Mass.

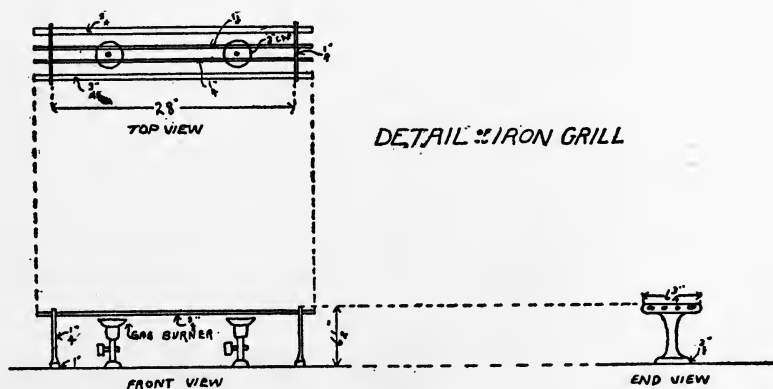

Fig. 27. Continuous rack, Bunsen burners, Mechanics Institute, Rochester, N. Y.

to the table. Piping is used for the lengthwise and crosswise supports of the wire.

Rack No. 2. In this design the supports, top, and movable cross-bars are of nicked steel. See Fig. 26 for dimensions and

details. This form is now used at Simmons College, Boston, Massachusetts.

Rack No. 3. This form is in use at the Mechanics Institute, Rochester, New York. Here the bars are not movable, and so the stand is less expensive. The price is included in the estimate of the cost of the whole table on page 65. (Figs. 27 and 52.)

## PRICE LIST

	<i>Each</i>	<i>20</i>
	<i>Stove</i>	<i>Pupils</i>
Hot plate No. 1 (with plain iron top).....	\$3.75	\$75.00
Hot plate No. 2 .....	2.50	50.00
Hot plate No. 3 .....	1.50	30.00
Rack No. 1, 24-inch table space, including burners.....		60.00
(Estimate given by New York plumber)		
Rack No. 2 (per running ft.).....	3.50	
Gas piping attachment, 45 ft., including connections for 40 Bunsen burners, and labor.....		36.18
Rubber tubing, 20 in., each burner, per yd.....	.33	
Bunsen burners, rose tops.....	.50	
Portable ovens for use on small stoves.....	2.00	
Zinc mats, asbestos-lined, 12 x 12 in.....	.40	

## IV. SINKS

Both large and small sinks may be used in the cooking room, the large at the side of the room, as in the home kitchen, the small sinks connected with the tables or standing near them. The use of a number of small sinks adds materially to the cost of the equipment, both in the cost of the sinks themselves and in the additional plumbing necessary. In an inexpensive equipment only one sink is possible, or two at most. The small sinks add greatly to the convenience of the kitchen, for the hot and cold water are thus near the work table. Where parallel tables are used, small sinks may be placed at the ends of each section; in the rectangular table, at the corners; with the single group tables, at the side or between the tables. (Figs. 19 and 20, and 49 and 50.) The chief objection to this plan is the additional plumbing that has to be cared for, as untrained workers may be careless in allowing scraps of materials to pass into the trap. This arrangement

does not work well unless attention is paid to training the pupils in the care of the sinks.

The best material on the whole is porcelain. An iron sink enameled is fairly desirable, though liable to crack. It is better to use a sink of the commercial type, rather than to have a sink, either zinc or slate, fitted into the work table. This latter arrangement does not allow for open plumbing, while the former does.

Nickel plate is a good material for all the sink attachments. A faucet permitting a continuous supply of water should be selected, since this allows for thorough flushing of the traps and also will furnish power for running a knife cleaner or some other mechanical device. The danger from flooding may be avoided by an overflow opening.

The trap should be of the S variety, easily opened for cleansing. The strainer over the trap should be fine.

A drain board is often provided for a large sink at the side of the room. If this is of wood, however, it is extremely hard to keep clean. A porcelain drain board is expensive, and needs always to have a cloth placed upon it when dishes are drained on it. A small kitchen table beside the sink, covered either with zinc or table oilcloth, is much less expensive and on the whole more cleanly, if not quite so convenient.

The prices range according to style and size from \$25 to \$80. Secondhand porcelain sinks may be purchased for from \$3 to \$6. This price is quoted in New York City, March, 1909.

## V. SHELVES AND CUPBOARDS

A good supply of shelf, cupboard room, and drawers adds much to the convenience of the laboratory. It is almost impossible to say just how much these articles should cost. The amount of space devoted to these fittings must vary greatly with the amount of wall space available. Then the lumber and carpenter work vary greatly in different parts of the country. The following suggestions, however, may prove useful.

Shelves may be made of packing boxes to accompany the cooking tables made of the same kind. (Fig. 40.) A ready-made

kitchen cupboard is furnished at house furnishing stores, that is not expensive and that may be used where no great amount of space is necessary. These ready-made cupboards have the advantage of doors which keep out dust. (Fig. 30.) Then, again, a carpenter can construct open shelves of some cheap wood which may be stained or painted and a curtain of washable material hung in front.

The next step in advance is the closed cupboard with glass doors the whole length, or with glass doors above, cupboards and drawers below. The woodwork may be either a painted wood or a better grade of wood with the natural finish. Shelves should be provided of varying widths; wide shelves or cupboards deep enough to hold large utensils, say, six-quart kettle or a steam cooker. A cupboard too deep or a shelf too wide, however, wastes space. A set of narrow shelves wide enough for a small jar economizes space and time. If several rows of jars are set upon a deep shelf it is not easy to find those that stand behind and it is difficult to keep the jars in order. There should be graded spaces between the shelves. This can be arranged for by having the shelves movable, unless it is determined beforehand just what articles are to stand upon the shelves.

#### PRICES

Packing box shelf, 13 x 27 x 41½ in., stained, with curtain rod and washable curtain (see Fig. 46).....	\$0.50
Open shelves, washable curtain (carpenter estimate, New York City, Jan. 1909), (per running ft.).....	.15
Cupboard, 40 x 15 x 72 in., furnished by a department store (see Fig. 36) .....	9.75
Cabinet, in pine, stained, 17½ in. long x 16 in. deep x 8 ft. 8 in. high (Estimate for town in Ontario, furnished by Macdonald Institute) .....	70.00

#### VI. OTHER FITTINGS FOR THE COOKING ROOM

It is well, if possible, to have a blackboard on the wall; if a movable blackboard, either hanging or standing on the floor.

Where hot water is not supplied and where there is gas in the building, it is necessary to have a gas water heater in the room.

Many designs are furnished by gas supply companies, and a good one can be bought for about \$10. If there is no gas and no hot water, a water back should be connected with the coal stove. If these arrangements are all impossible, a large pail should be provided where a sufficient amount of water can be heated on the stove.

*Supply Tables.* It is necessary to have somewhere in the room a table for supplies, which may also be used by the teacher.

If space allows, it is well to have two tables, one devoted entirely to the teacher's use. An ordinary kitchen table will, of course, serve for the former, which may be left unfinished, or covered with a kitchen oilcloth. A convenient table for the teacher, especially if she demonstrates, is one of the ready-made tables with drawers underneath for utensils and some provisions. One of this type can be obtained for from \$5 to \$6. Where the rooms are large and not near the source of supplies, it is well to have the supply table on rollers. This may have a shelf underneath.

Rolling table, soft wood, one shelf underneath, top and shelf zinc-covered, 36 inches long by 27 inches wide by 32 inches high, cost in New York in 1906, \$8. A rolling table, oak, one shelf underneath,  $37\frac{1}{4}$  inches long by  $17\frac{3}{4}$  inches wide by 31 inches high, cost in New York in 1902, \$36.

*Refrigerators.* These range in style and price from the small and inexpensive ice box to the expensive patterns with many compartments and very fine finish. The size of the refrigerator depends, of course, upon the amount of work done in the kitchen. The large refrigerator, of course, makes it possible to keep supplies over from day to day and class to class, when these are meeting frequently. The prices range from \$5 to \$75 upward. A refrigerator of the latter size gives space for materials for 400 students a week. Pains should be taken to select a refrigerator constructed on good principles, if possible with a tiled or enameled lining. There are many of these on the market, well packed to save ice and well ventilated. The discount from the printed price is always large to any school. A good refrigerator well cared for is an excellent object lesson.



*Plate Warmers.* Where steam heat is available a plate warmer may be installed which will also serve as a bread raiser. Plate warmers are furnished by radiator companies for use in dining rooms, or a plate warmer can be constructed of sheet iron by a local plumber.

## VII. UTENSILS

Great care needs to be exercised in the selection of utensils for school use, since the success of the work depends so much upon having the right tools at hand. It is not economy to buy poor utensils. It is better to have one knife with a good edge than two cheaper ones bought from the ten-cent store. It is also better, where funds are low, to have one good knife rather than an inferior knife and an apple corer. Few people recognize the fact that a good knife is an indispensable kitchen tool.

In general, utensils should be selected that are easily kept clean, without seams, angles and cracks where the food easily collects. Many utensils and dishes that are attractive to the eye are found lacking in these requirements. It is well to discover whether a pitcher will pour, before it is purchased. A coffee pot with a lip rather than a spout is not only labor saving, but furnishes better coffee, since the long spout is often imperfectly cleaned.

*Materials.* On the whole, some kind of enamel ware is the best for most utensils; the attractive white enamel does not wear so well as some of the darker colors. Poor tin is not economical, as it does not wear well. The enamel ware is good for measuring cups, plates, pitchers, saucepans, and those utensils used where the heat is not too intense. Frying pans should be of iron or steel.

Earthenware should be used when possible for bowls and jars, and the heavier kind for certain cooking processes, as in the baking of pop-overs, puddings, and the slow cooking of meat and other food in the oven.

*Sizes.* For individual work the utensils should not be too large; a pint bowl, pint saucepan, and a double boiler holding a quart are large enough. Some large utensils, both kettles and pans, are, of course, to be provided for group work. It must be

remembered that no two teachers will select identical sets of utensils. The following list is intended to give what may be called a fair average; this could be used in high-school work as well as in elementary-school work. Such a list would form part of an equipment costing, say, from \$400 to \$500 or more. It would need to be cut down for an equipment costing from \$200 to \$300. In cutting down this list fewer articles could be furnished to each pupil and a number of utensils could be omitted, as, for instance, the set of larding needles. The ice-cream freezer can be omitted and the homemade variety substituted—a large tub and tin pail or wooden pail.

## SUGGESTED LIST OF UTENSILS

## One for Each Pupil

(\*Two Each)

	<i>Size</i>	<i>Material</i>	<i>Price</i>
Bowl*	1 qt.	Earthen	\$0.16
Bread board	Small	Wooden	.45
Dover beater			.10
Egg beater	Medium	Wire	.05
Frying pan	Small	Iron	.15
Kitchen fork		Steel, wooden handle	.15
Kitchen knife		Steel, wooden handle	.15
Mat	8 in. sq.	Asbestos	.05
Measuring cup	Half-pint	Tin	.05
Mixing spoon	Medium	Wooden	.06
Pan	Small	Granite	.22
Pepper shaker		Glass	.15
Plate		Granite	.18
Pop-over cup		Earthen	.05
Salt shaker		Glass	.15
Saucepan with cover	1 pt.	Granite	.30
Spatula	Medium	Steel	.24
Tablespoon		Plated	.25
Teaspoon*		Plated	.15
Vegetable knife		Steel, wooden handle	.15
		Cost per pupil	\$3.21
		For 20 pupils	\$64.20

One for Two Pupils

(†One for Each Preferred)

	Size	Material	Price
Biscuit cutter		Tin	\$0.15
Bread pan	Medium	Tin	.25
Coffeepot	1 pt.	Granite	.25
Colander	Medium	Tin	.38
Dishpan	Small	Granite	.75
Double boiler†	1 qt.	Granite	.50
Grater	Small	Tin	.08
Potato masher	2	Wire, wooden handle	.10
Rinsing pan		Granite	.50
Rolling-pin		Wooden	.15
Scrubbing brush	Small	Wooden back	.05
Skimmer	Small	Tin	.04
Strainer	Medium	Tin	.15
Teapot	1 pt.	Earthen (Japanese)	.25
Vegetable brush	Small	Wooden back	.05

Cost for 2 pupils \$3.65

For class of 20 \$36.50

One for Four Pupils

Apple corer		Tin	\$0.10
Bowl	3 qt.	Earthen	.15
Chopping bowl		Wooden	.15
Chopping knife		Steel	.45
Muffin pan, deep	8 in. pan	Block tin	.40
Nutmeg grater		Tin	.04
Pitchers	1 and 1½ pts.	Earthen	.10, .15, .25
	1, 2, and 3 qts.		.40, .55 (av.) .29

Cost per 4 pupils \$1.58

For class of 20 \$7.90

One for Ten Pupils

Baking dish	3 pts.	Earthen	.18
Cake pan	Medium	Tin	.50
Double boiler	2 qts.	Granite	1.00
Griddle	Medium	Steel	.60
Griddle cake turner		Iron	.05
Kettle	4 qts.	Granite	1.50
Lemon squeezer		Glass	.05

	Size	Material	Price
Saucepan	2 qts.	Granite	\$0.65
		Cost per 10 pupils	\$4.53
		For class of 20	\$9.06

## One for Twenty Pupils

(\*Two Preferred)

Bread knife		Steel	\$0.49
Can opener			.10
Cleaver		Steel	.75
Coffee mill			.83
Coffeepot	2 qts.	Granite	.85
Corkscrew			.25
Flour sifter		Tin (revolving handle)	.15
Fruit jars, 2 doz.	½ pt.	Glass (lightning)	2.24
Frying kettle*	Large	Iron	1.88
Funnel	Medium	Tin	.15
Ice-cream freezer	3 qts.		2.00
Jelly glasses, 2 doz.		Glass (tin covers)	.76
Knife sharpener	Wheel		3.00
Larding needles, set		Steel	.59
Measure	1 pt.	Tin	.15
Measure	1 qt.	Tin	.25
Meat knife	Medium	Steel	1.00
Pudding mould*	3 qts.	Tin	.39
Scales (spring)	To 12 lbs.		1.25
Steamer*	Medium	Tin	1.50
Strainer	1 qt.	Wire	.30
Teakettle	Large	Granite	1.30
Toaster	Medium	Wire	.25
Tray	Medium	Japanned	.35

---

 \$20.78

## Articles for Holding Provisions

1 bin	Large	Metal, made to order	\$2.00
6 covered jars	4 qt.	Earthen	1.20
6 covered jars	6 qt.	Earthen	1.80
1 doz. Jap. lid jars	1 qt.	Glass	2.00
1 doz. Jap. lid jars	2 qt.	Glass	3.60
1 doz. screw-top or glass- stoppered jars	1 pt.		3.00
Labels of different sizes			1.00

	<i>Size</i>	<i>Material</i>	<i>Price</i>
1 large wire box (like cheese box)			\$5.00
As much cupboard and closet room as possible			<hr/>
			\$19.60
	Towels, etc.		
40 dish cloths	1/4 yd.	Linen	\$2.00
50 dish towels	1 yd.	Linen	7.50
6 roller towels		Linen	1.80
			<hr/> 11.30
Total cost of utensils for class of 20.....			<hr/> \$169.34

### VIII. EQUIPMENT FOR HOUSEWORK

A list of articles is appended which is sufficient for the ordinary school kitchen. For the class teaching in housework, a larger number of articles has to be provided. It is possible, however, in an elementary or high-school class to have the cleaning of the room treated as group work, which of course reduces the number of articles of any one kind.

Blacking brush .....	\$0.25
Broom .....	.35
Cheesecloth dusters (10) .....	.50
Dustpan .....	.25
Floor brush .....	.35
Lamp cloths (2) .....	.15
Mop and handle .....	.40
Pail, indurated fiber.....	.30
Scrubbing brush .....	.30
Whisk broom .....	.20
Window cloths, cleaning cloths, etc.....	1.00
	<hr/>
	\$4.05

### IX. APPARATUS FOR SCIENTIFIC EXPERIMENT

It is well in a school kitchen to have a few articles such as are used in a chemical or physical laboratory, of the simple and inexpensive kind. These are useful in performing simple experiments, and do not occupy a large space for storage. In the University of Wisconsin a table for chemical experiment is placed at the side of

the room. This is certainly a convenient arrangement where the work in cookery is on a scientific basis. The list appended is for school kitchens.

1 doz. 4 oz. beakers.....	glass.	\$1.80
1 doz. 6 oz. beakers .....	glass,	2.00
1 doz. ½ pt. flasks .....	glass,	2.15
2 doz. nests test tubes (4, 5 and 6 in.) .....	glass,	1.92
1 doz. 2 in. watch glasses .....		.35
1 microscope (either American or German imported duty free by schools) .....		27.00
		<hr/>
		\$35.22

## X. ILLUSTRATIVE MATERIAL AND BOOKS

In domestic science work the materials ordinarily used may be classed as illustrative material; but in addition to this, the work is enriched by the use of charts and specimens.

*Charts* would include those that have to do with the nutritive and economic value of foods and those that show the different cuts of meat. Of the former there are very few ready-made on the market. A small colored Register of Foods may be obtained from Whitcomb & Barrows, Huntington Chambers, Boston; and they also have on sale charts used on the Continent of Europe and in England. Other meat charts may be obtained from Pratt Institute, Brooklyn, New York. Meat charts and photographs of meat cuts are furnished by the Museum, Teachers College, Columbia University. A series of fifteen nutrition charts has been prepared under the supervision of Dr. Langworthy, Office of the Experiment Stations, Department of Agriculture. These may be obtained for \$1 prepaid, from the Superintendent of Documents, Washington, D. C. They may be mounted for about 35 cents each by some firm that does this kind of work. Homemade charts may be prepared from cuts in the Bulletins of the Department of Agriculture and other pamphlets by using a device for enlarging drawings, known as the pantograph. These drawings can be made on cloth or paper, outlined in either oil or water color, the surface washed over if desired. If made of cloth they are easily rolled or folded, and may be carried from school to school.

Pictures illustrating the production and manufacture of food materials may also be neatly mounted upon cloth and hung in the schoolroom or carried from place to place.

*Specimens* of foods and laundry materials may be placed in jars or bottles, labeled and kept upon shelves, thus forming a small household museum. Specimens may often be obtained from large manufacturers, as, for instance, manufacturers of cocoa and of flour, who have on hand sets of specimens for schools, which may be obtained free of charge or at very slight cost. An attractive exhibit of some one kind of food material is made by mounting small bottles containing the materials on a large and heavy card, which may also have pictures pasted upon it. Specimen cards of this latter kind are in use abroad, and may be obtained from French and German dealers; but these are costly. The home or school-made variety is equally useful and costs very little. A card with pictures of several varieties of cereal and with specimen bottles of typical forms of cereals is interesting to older pupils as well as to children.

If the school library does not contain suitable reference books, at least a few should be provided. The list should include a standard book on physiology and hygiene, chemistry of foods and nutrition, and physics. The Library of Home Economics, published by the American School of Home Economics, Chicago, Ill., affords an excellent set of references. To these should be added the Farmers' Bulletins, to be obtained from the Department of Agriculture, Washington, D. C. Many of the State Agricultural Colleges publish bulletins on food and sanitation that are excellent for reference.

## XI. STUDENT'S UNIFORM

In the school kitchens pupils are expected to wear aprons and often caps and cuffs. This is one of the difficult details for a teacher to control. It is almost impossible to have the aprons, caps and cuffs uniform unless they are provided by the school, and it is quite difficult to have fresh aprons always on hand. Efforts should be made at the beginning of the year to impress

upon the children the importance of having the proper outfit and of having it properly cared for. The apron should be made with a pocket large enough to hold the handkerchief. Sometimes these articles can be made in the school, in the domestic art classes; they might even be laundered in the school where there is adequate equipment. Lockers or boxes may be provided where each child is to keep her cap, apron, and cuffs, and the teacher must inspect the folding and putting away and see when laundering is necessary.

Teachers differ in their opinion as to the utility of the cap. The only cap that is really of any use is one made like a dusting cap which completely covers the hair. A small cap is useless and therefore an unnecessary article. If none is worn, the teacher must then see that the hair is always neat and tightly done for the cooking classes.

In college classes a wash dress is necessary. Woolen skirts are uncleanly in a laboratory. The extra amount of dirt in a laboratory resulting from the use of woolen skirts would be a surprise to one who has not observed closely. The wash dress does cause some inconvenience to the students in the matter of cost, and also in the matter of changing from the ordinary dress. This difficulty may be partly obviated by having the costume white rather than of a colored wash material. The custom of wearing the white wash waist all through the winter is now so common that the only change necessary is from the woolen skirt to a white skirt. Most women have some style of white duck skirt; or such a skirt if purchased for the uniform will be useful afterward.

It seems hardly worth while to demand of the adults that the dress shall be absolutely uniform,—if white and washable, made simply, with the simplest kind of neck arrangements, this is all that need be required. Sleeves should not be too long, or should be easily turned back.

The cooking teacher should always wear wash dresses and all her appointments, of course, should be immaculate. The white skirt may not be possible for the elementary-school teacher who goes from school to school, but at least she should go into the laboratory with a well-brushed skirt and all of her other appointments fresh.



## CHAPTER IV

### THE DINING ROOM, LAUNDRY, EQUIPMENT FOR HOME NURSING

#### I. DINING ROOM

THE dining room affords an opportunity for a combination of comfort, convenience, and beauty. It is often necessary to have the furnishing of the school dining room cost but little. This necessity results sometimes in a room where the furnishings serve the purpose in a practical way, so far as the serving is concerned, and yet the room fails to be artistically beautiful. It is worth while to take time to select furniture of good lines and to make a harmonious color scheme. If the lines and construction of the sideboard, table, and chairs are good, the wood need not be costly. An inexpensive wood may be stained to harmonize with the walls and floor covering. Good colors are now found in many inexpensive rugs, and the wall need not have anything more expensive than the calcimine wash. Washable curtains at the windows, of an artistic material, add very much to the attractiveness of the room. Pleasing effects may be obtained for little cost.

In a school where home decoration is taught, the color scheme may be worked out either in the art or domestic art department. Where there are looms, a rug might be woven for the floor and curtains made for the windows. If there is a manual training department in the school, even the chairs and tables might be designed and constructed in the school itself.

In the selection of linen there is also an opportunity for the domestic art teacher and pupils to assist; and good designs may be found even in cheap materials. In the table linen a dotted design, known commercially as the "snowdrop," and another, the "fleur-de-lis" pattern, are always in good taste. In regard to quality, it is economy to buy a good grade of linen. Where

funds are very limited a mercerized cotton tablecloth is very satisfactory if it is laundered with a little starch in the water; it looks better and wears better than the coarse linen filled in by the manufacturer to make it appear of a finer grade. In settlement work or even in rural schools, it is suggested that the white table oilcloth should be used. This may, at first, seem undesirable to many teachers, but those who are familiar with conditions in our large cities know that a clean table oilcloth is better than none, or than a soiled red table cover. In the country it would be a boon to some housekeepers to know that white table oilcloth may be used instead of a cloth that needs constant washing. A table covered in this way and neatly set is really very pleasing.

The art department should lend its aid in the selection of dishes. In buying these it is well to select those which are known as open stock, from which single dishes may be bought when it is necessary to replenish the stock. In the china there should be no very strong color, as this allows for variety from time to time in the table decoration. White china with a raised pattern, or with a simple band of gilt is good, because any color in the table decoration may be used with it. Since the china is not used so constantly as in the home dining room, a cheaper grade of china with a gilt band will wear for some length of time.

The following list of articles is merely suggestive. Dining room tables and chairs may be bought for even less than the price indicated, though it would perhaps be better, where strict economy is necessary, not to attempt to buy a cheap dining room table, but to use a good kitchen table. This would be entirely feasible where the table is set in the cooking room.

Fewer dishes could be bought than the list indicates, for the table is seldom set for more than six or eight. It is well to have as many as a dozen of each to allow for breakage, or for the occasional serving of a larger number of people. This list would be very insufficient for elaborate serving.

A few pictures of dining rooms are appended in Figs. 28, 37, 38, and 39. The illustration of the table in the temporary room at the University of Nebraska shows how pleasing an effect may be obtained with simple furnishing. One of the most beautiful

dining rooms in the country is that of Pratt Institute, Brooklyn, New York.

ARTICLES FOR SETTING THE TABLE AND SERVING

	<i>Size</i>	<i>Material</i>	<i>Price</i>
Table felt			\$1.50
Dining room table and chairs		Oak	20.00
3 tablecloths		Linen	7.50
2 doz. napkins		"	5.00
1 doz. doilies		"	3.00
1 doz. bowls (for cereal)	Small	China	1.80
1 doz. cups and saucers	Tea	"	1.80
1 doz. cups and saucers, A. D. Coffee		"	1.50
1 doz. dinner plates		"	1.20
1 doz. soup plates		"	1.20
1 doz. tea plates		"	1.00
1 bread plate		"	.25
2 covered vegetable dishes	Medium	"	.75
2 uncovered " "	Medium	"	.40
1 platter	Large	"	1.20
1 " "	Medium	"	.60
1 " "	Small	"	.40
1 salad dish	Medium	"	.44
1 doz. sauce dishes	"	"	.75
1 teapot	"	"	.69
1 cream pitcher	"	"	.15
1 sugar bowl	"	"	.35
1 fruit dish	"	Glass	.50
½ doz. salt shakers	Small	Glass, silver top	1.20
¼ doz. pepper shakers	"	Glass, silver top	1.20
2 doz. teaspoons		Silver plated	5.00
1 doz. dessertspoons		Silver plated	3.00
½ doz. tablespoons		Silver plated	2.50
1½ doz. knives		Silver plated	4.00
1½ doz. forks		Silver plated	5.00
1 doz. tumblers		Glass	.60

---

\$74.48

II. THE LAUNDRY

The teaching of laundry work is not common in the public schools of this country, nothing more being taught as a rule than the washing of towels in the school kitchen. In a few of the man-

ual training high schools there are well-equipped rooms for laundry work, and a number of training schools for teachers give brief courses.

In the schools and also the summer vacation schools of New York City there is work in laundering, and in some settlement schools. (Figs. 34 and 35.)

In England and on the Continent, even in the elementary schools the laundry work is made almost as prominent as the cookery. As much space is given to the laundry equipment and in some cases as much time. It would seem well if in the United States at least enough lessons could be given to teach the first principles of laundering. Opportunity is afforded for the application of certain principles of chemistry when studying the difference between hard and soft water, bluing and soaps, and chemicals for the removal of spots and oil. In our large cities there is certainly need to teach good laundry methods.

*Portable Equipment No. 1.* Designed and used by Miss Mary Beals Vail, formerly of Teachers College. (Figs. 31, 32, and 33.)

An equipment such as is given in the appended list was in use for a number of years at Teachers College, Columbia University, with a somewhat larger number of articles. The work was done in the school kitchen and as many as 12 or 15 pupils worked at one time. In the high-school classes the pupils laundered shirt waists, as well as articles easier to do up. College classes had courses of 15 lessons, two hours each, including all the simple processes of laundering, and even some fine starching.

The articles laundered were dried on portable wooden horses. In the college classes experimental work was done in the use of washing machines, electric and denatured alcohol irons; but the variety of articles given is sufficient for elementary and high-school work.

#### EQUIPMENT FOR CLASS OF EIGHT

a. Articles that are a usual part of a school kitchen equipment:

1 agate soap cooker .....	\$0.65
1 agate double boiler for starch.....	1.03
1 teakettle .....	.97
1 dish pan, 14 qts. ....	.63

---

\$3.28

*Dining Room, Laundry, Equipment for Home Nursing* 51

1 yellow earthenware bowl, 1 qt. ....	\$0.12
1 yellow earthenware bowl, 2 qt. ....	.16
1 yellow earthenware bowl, 4 qt. ....	.25
8 yellow earthenware bowls, 1 pt. at 5c .....	.40
2 tin measuring cups, ½ pt. at 10c .....	.20
6 tablespoons at 7c .....	.42
6 teaspoons at 5c .....	.30
8 case knives .....	.50
1 wooden spoon .....	.05
1 towel roller .....	.10
3 roller towels (7½ yds. at 12½c) .....	.88

---

\$3.38

Less 10% .33

---

\$3.05

---

\$6.33

*b. Necessary articles to be purchased:*

1 large fiber tub .....	\$0.83
12 small fiber tubs at 60c .....	7.20
1 fiber pail .....	.23

---

Net price (less discount) ..... \$8.26

4 flatirons, 7 lb. at 55c .....	\$2.20
4 flatirons, 6 lb. at 45c .....	1.80
8 flatirons, 5 lb. at 32c .....	2.56
8 flatirons, 4 lb. at 40c .....	3.20
8 Troy polishers at 45c .....	3.60
2 flounce irons at 56c .....	1.12
8 iron stands at 5c .....	.40
8 iron holders (asbestos) at 4c .....	.32
1 large wringer, "Universal" .....	4.25
2 small wringers at \$2.50 .....	5.00
1 tin dipper .....	.20
1 oval clothes basket .....	1.25
1 oval boiler .....	1.25
6 benches (4 ft. long) at 90c .....	5.40
8 skirt boards at \$1.50 .....	12.00
(with folding supports, uncovered, 4½ ft. long.)	
8 small washboards at 40c (¾ usual size, special order) ....	3.20
2 clotheshorses at 88c, 4 ft. high, fourfold .....	1.76
1 fringe brush .....	.63

3 soft brushes at 38c .....	\$1.14
3 whisk brooms (sprinklers) at 18c .....	.54
100 ft. clothesline .....	.90
Clothespins .....	.10
Safety and toilet pins.....	.25
1 yd. white flannel .....	.40
10 yds. cheesecloth at 4c .....	.40
Skirt board covers, 10 yds. unbleached cotton @ 8c .....	.80
4 yds. cotton felting (54 in. wide) at 50c .....	2.00
	<hr/>
	\$56.67
	Less 10% 5.66
	<hr/>
	\$51.01
	<hr/>
Kitchen utensils if purchased .....	\$59.27
	6.33
	<hr/>
Total cost of equipment .....	\$65.60

Smaller white oval tubs may be used instead of the brown fiber ones with little difference in price. With these the toy washboards are large enough. Tables may be found better than boards, especially as the adjustable supports for the boards are seldom firm when set up. Boards of four feet would be amply long for children. If the room to be used for a laundry does not contain a stove and running water, both would have to be provided at increased cost. If economy must be practiced, one wringer will be sufficient and but one small tub for each girl; this would make but five benches necessary. Flatirons may be purchased at 6 cents per pound, except for polishers and flounce irons. The polishers may be dispensed with if no thick starch work is to be done. Flounce irons are a luxury.

*c. Supplies:*

3 doz. small bars Ivory soap @ 50c .....	\$1.50
Starch .....	.30
Bluing .....	.25
Beeswax or paraffin .....	.40
Borax .....	.20
Ammonia .....	.20

White wine vinegar .....	\$0.10
Salt .....	.05
	<hr/>
	\$3.00

*Portable Equipment No. 2*, Boardman School, New Haven High School, New Haven, Conn. Designed and used by Miss L. Ray Balderston.

1 wringer	4 bosom boards
1 polishing iron	1 sleeve board
2 doz. irons	7 or 8 ironing boards
4 washboards	1 clotheshorse
4 washtubs	Clothesline
2 benches, folding	

The kitchen laboratory was used for the classes. Clothes were hung in the kitchen to dry if there was no afternoon class following; otherwise, they were hung in the science lecture room, a small room which was used for Home Nursing, Waitress Work, and for Food Lectures. The benches and tubs were kept in the toilet room adjoining and the smaller things in the kitchen pantry. The instructor's end of the room was used for washing, while the ironing was done by laying skirt boards on table tops or across on inside of horseshoe. The irons were heated on the burners at the desk. The washing of one week was the ironing of the next.

All kinds of garments were washed by the students, who brought them from home. The shirt, collar and cuff lesson was demonstrated by an expert laundress. The class was composed of seniors, and always constituted one-half the senior class, no matter the number. The last class taught in the room had twenty-six members. A colored woman, who was an expert laundress, acted as assistant.

*Stationary Equipment.* Where the equipment is stationary, a room or rooms should be devoted to laundry purposes only. It is essential here to have the floor of a material that can be most thoroughly cleansed. Although it may be fatiguing to the workers, the floor should be of either tile or cement. Those who are

working in the laundry should be required to wear rubber heels at least, if not rubber soles. The floor should be slightly slanted, with a drain at the side or in the corner so that the floor can be flushed with either hose or buckets of water. The wall also should be washable its entire height. The tubs should be seamless, and therefore porcelain is the best material. The color of the tubs should be white. A buff porcelain tub makes it impossible to judge when the clothes become clean; and it is difficult to decide upon the shade of the bluing water.

One of the best equipped laundries for college work is that at Macdonald Institute, Guelph, Canada. A well-equipped laundry is to be found at the Manual Training High School, Saginaw, Mich. Appended find the equipment used at the Macdonald Institute (see also Fig. 36). The laundry in the School for Household Arts, Teachers College, Columbia University, has an equipment for hand work, and also a small equipment of machinery such as is used in a steam laundry. This laboratory is used by those who are in training as teachers and also for institutional and hospital workers.

#### LAUNDRY CLASSROOM, MACDONALD INSTITUTE

12 tables—combination of settee and ironing table with a box seat which holds all the ironing blankets, sheets, etc. Top is cypress wood, and the body of birch and hard wood. Bought unfinished for .....	\$99.00
(Finished by the college painter.)	
2 supply tables—oak with white wood tops .....	12.00
Mangle .....	16.00
Gas plate, 3 burner .....	4.25
Table, zinc-covered, for gas plate.....	3.75
Washing machine, 19th Century.....	14.00
Washing machine, Knoll .....	8.00
Table, common table .....	2.75
Small equipment .....	118.25
	<hr/>
Total .....	\$278.00

The above does not include the cost of the steam dryer, the twelve crockery tubs and their stands, nor the gas fittings and plumbing, which were part of the building contract.



### III. HOME NURSING

The following list of articles has been used in a class for home care of the sick. It has already been suggested that this work may be taught in class rooms if there is a space at one end or at the side of the room where a bed can be placed. All the small articles may be kept in a case or cupboard at the side of the class room. This arrangement means, of course, that there must be a place where the bedstead and spring may be stored. If there is no room available for this purpose, and if the expenditure of \$16 is too much, a large doll's bed will answer the purpose very well, a large doll being the patient. Where there is a suite of rooms, the bedroom is, of course, available for a part of the home-nursing work.

#### SUGGESTED EQUIPMENT

Bedstead, steel frame, white enameled, woven wire spring.....	\$6.00
Mattress, sanitary, woven hair.....	10.00
Hair pillow .....	1.00
Feather pillow .....	.75
6 cotton sheets .....	5.00
4 cotton pillow slips .....	.60
1 bedspread .....	2.00
2 single blankets .....	4.00
Mackintosh, 1½ yds. ....	1.13
Hot water bag .....	.90
Fountain syringe .....	1.50
Davidson syringe .....	.75
Muslin bandages (7 yds. muslin) .....	.35
Gauze bandages .....	
Samples of material for flannel bandages .....	
Samples of material for plaster bandages .....	
Samples of material for rubber bandages .....	
Absorbent cotton .....	.10
Oiled muslin .....	.25
Rubber tissue .....	.25
Bed tray .....	1.00
Bed rest .....	2.00
Hot water plate .....	.75
Feeding cup.....	.20
Drinking tube .....	.02
Medicine bottles, poison, etc.....	.25
Medicine dropper .....	.02

Medicine glass, graduated .....	\$0.25
Minim glass .....	.75
6 oz. graduated glass .....	.50
Eye bath .....	.20
Eyelid rod .....	.06
Probe .....	.50
Forceps .....	
Scissors .....	1.25
Thermometer, clinical .....	1.25
Thermometer, bath .....	.10
Foot tub .....	1.00
Fomentation wringer and flannels .....	
Flaxseed .....	
Flaxseed meal .....	
Mustard .....	
	<hr/>
	\$44.68

## CHAPTER V

### THE PURCHASE AND CARE OF EQUIPMENT

*Purchase.* A knowledge of the market and of economical methods of buying is essential to success in the purchasing of an equipment.

The plans and lists need to be worked over and over again, to determine how to divide the budget wisely among the different parts of the equipment. It is not often that funds are so ample that the teacher can have what she considers ideal; the problem then is to decide where to retrench without crippling the work.

In order to avoid freight or express rates it is usually best to purchase from a source of supply near the school. In some cases it is possible to obtain better discounts and also a better grade of articles at a distance. It is best always, if possible, to see the articles to be purchased; but many firms now issue illustrated catalogues, and if the firm is known as reliable it is perfectly safe to order by mail.

In the case of stoves, large discounts may be obtained from the manufacturer, and one often gets a better article by purchasing of some large and well-known firm. Sometimes the firm pays all the transportation rates. A discount is usually given by all firms selling to a school, especially if the quantities are large.

The method in which the funds are handled is, of course, decided by the school authorities, and the teacher can do nothing but follow the plan given her. It is necessary that she should keep an accurate account of everything purchased, for her own use and convenience, at least; and she will probably be required to do so by the authorities in order that all bills may be verified.

*Care of Equipment.* It is the duty of every instructor in charge of domestic science laboratories to be responsible for the best possible use of the whole equipment. If there are maids to do a part of the work, they should be taught the best methods

for cleansing all parts of the rooms and all the equipment. If the bulk of the work is done by the pupils, all heavy work being left to the janitor, then the housework must not be neglected for the cooking, the laundering, or whatever the regular class work may be. It is in this matter of housework that the short hours allowed in the school program make the work of the domestic science teacher difficult. Many cooking processes cannot be hurried, and if anything is neglected it is too frequently the cleaning and the general housework. This is ruinous to an equipment. With proper care the wear and tear of the equipment means but very little in dollars and cents per annum; but hurried and careless dishwashing and the slovenly cleaning of tables and sinks tend to deterioration in every part of the equipment. Pupils should be made to understand, at the beginning of their work, that the housework is of supreme importance. In addition to the daily and weekly care, there are also other duties in connection with the care of the equipment.

*Inventory.* A careful inventory should be taken at least once a year. All articles should be removed from drawers, cupboards, and closets; articles separated from each other, each kind being placed by itself, and these articles should be counted and listed. This is also the time to inspect each article to see which are to be discarded, which are to be replaced, and which need extra cleansing if work has been careless. It is hardly possible with untrained workers to find utensils in perfect condition. The inventory should be kept either in books or in a card file. The card file makes it possible to change the inventory from time to time as new articles are added or old ones discarded. A tin or wooden box equipped with cards, with alphabetical guides, may be obtained from any office furnishing company. A card should be given to each kind of article with the name, material, size, price, place and date of purchase listed, also number in stock. One card will last for ten years, using a line a year.

*Storing of Equipment When Not in Use.* If the school kitchen is not used for the summer months, great care is necessary to avoid deterioration. All articles should, of course, be thoroughly cleansed and made perfectly dry. Stoves should be

covered with paper, and nickel-plated attachments coated thinly with vaseline. Unless the building or the climate is damp it is not necessary to do more than to wrap utensils in papers, though it is a good plan to coat cutlery thinly with vaseline.

In a school kitchen, in one of our large cities, one of the instructors has trained the children each year by having them assist in the work of putting away all utensils. In the fall she gives her first lesson in housework by having the pupils clean the kitchen, take out all the utensils, wash them, and put them in place. This might be possible in almost any school. If there is any amount of equipment it is a heavy task for one person.

Unless the janitor of the building can flush the traps from time to time during the summer, they should be filled with rock salt after a thorough cleansing with hot water and soda and complete flushing.

## CHAPTER VI

### TOTAL COST OF EQUIPMENT

A STUDY of the material presented shows that the total cost of equipment may vary from one hundred dollars to several thousand. For \$500 a room may be well equipped for twenty pupils. This allows a cooking table with drawers built in, an enameled sink, two stoves, good designs for the individual stoves, a liberal supply of small utensils, and plain dining room fittings. The data given show that the tables and the stoves may be made the most costly part of the kitchen equipment. The varying costs of labor and material in different sections of the country and the fluctuations of the market from year to year make it impossible to give a total cost that will fit any actual situation exactly.

The following list is given as an approximate estimate. This does not, however, exactly represent any one equipment in actual use.

#### SCHOOL EQUIPMENT FOR FIVE HUNDRED DOLLARS

##### *Twenty pupils*

Cooking tables, single drawer, maple top, ash frame.....	\$100.00
20 small stoves, burners and tubing.....	30.00
20 stools .....	10.00
2 gas ranges .....	37.00
1 refrigerator .....	15.00
1 porcelain sink .....	25.00
2 kitchen cabinets .....	19.50
Utensils .....	160.00
Dining room table and chairs .....	20.00
Linen and china .....	30.00
Home-nursing equipment .....	10.00
Supply table .....	8.00
Laundry equipment .....	30.00
Housework equipment .....	4.00
Total .....	\$498.50

Following are a number of equipments kindly given for this publication by the officials of the schools in question. It will be seen that both public schools and higher institutions are mentioned, and that the estimates come from different parts of the country.

PACKING BOX EQUIPMENT

Designed and used by students, Department of Domestic Science, Teachers College, Columbia University. This equipment is intended to show what may be done in a district school where available funds are limited. (Fig. 40.)

The number of tables that could be used depends, of course, upon the space in the schoolroom. If the space is small, even one table would answer the purpose, if the teacher is sufficiently ingenious to fit in the work of cooking with her other subjects. With a small equipment, two or three children could work at a time, say, one or two days a week.

Packing boxes may be obtained in almost any neighborhood, and the painting, carpentry work, and sewing be done by the pupils in the school, thus making the cost very low. In the winter the heater might be used for cooking, if the top is flat.

UTENSILS FOR SIX PUPILS

(Prices, New York City, 1907)

<i>Individual</i>	<i>Cost</i>	
	<i>For one</i>	<i>For six</i>
1 white bowl, 1 qt. ....	\$0.05	\$0.30
1 measuring cup .....	.05	.30
1 granite pan .....	.10	.60
1 saucepan .....	.05	.30
1 tin pail .....	.10	.60
1 steel fork .....	.05	.30
1 steel knife .....	.05	.30
1 tablespoon .....	.02½	.15
2 teaspoons .....	.01⅔	.10
	<hr/>	
	\$0.49 1/6	\$2.95
1 oil stove .....	.70	4.20
1 asbestos mat.....	.05	.30
	<hr/>	
	\$1.24 1/6	\$7.45

*For Class*

3 bread boards .....	\$0.15	6 quart jars .....	\$0.30
1 rolling-pin .....	.05	3 wooden pails with covers ..	.30
3 baking powder can tops (for cookie cutters) .....		6 dish towels .....	.48
1 flour sifter .....	.10	3 dish cloths .....	.15
1 large frying pan .....	.25	3 hand towels .....	.15
1 double boiler .....	.50	1 broom .....	.15
1 qt. kettle .....	.25	1 dustpan .....	.05
1 tea kettle .....	.50	1 brush .....	.10
1 broiler .....	.20	1 scrubbing brush .....	.05
1 garbage can .....	.25	1 scrubbing pail .....	.10
2 pitchers .....	.25	1 Dover beater .....	.05
2 apple corers .....	.10	1 pepper shaker .....	.05
1 chopping knife .....	.10	1 salt shaker .....	.05
1 chopping bowl .....	.05	1 colander .....	.10
6 muffin tins at 2c .....	.12	1 baking dish .....	.10
2 layer cake tins .....	.10	1 bread knife .....	.25
3 dishpans .....	.45	1 coffee mill .....	.25
3 rinsing pans ..	.30	1 corkscrew .....	.10
1 strainer .....	.05		
6 china plates .....	.30		<hr/> \$15.50
3 mixing bowls .....	.30	Packing box table .....	1.00
6 sauce dishes .....	.15	Packing box cupboard.....	.50
6 cups and saucers .....	.30		<hr/> \$17.00
1 coffeepot .....	.25	Large blue-flame oil stove ..	10.00
1 teapot .....	.10		<hr/> \$27.00
3 bread pans .....	.15		

## MACDONALD INSTITUTE RURAL SCHOOL EQUIPMENT

Designed by Miss Grace Greenwood, of Macdonald Institute, Guelph, Canada (Figs. 41, 42, and 43). An effort has been made to carry out the plan of setting up an inexpensive class-kitchen equipment to illustrate what may be done in rural schools, or in other places where gas stoves, plumbing, and separate rooms are out of the question. An equipment of trestle tables, cupboards, and utensils has been purchased and installed in one of the rooms left vacant by the Manual Training Department. It is suitable for individual work with a class of twelve and is now being tested by use with a public-school class. Following is a list of the equipment showing the exact cost of each item:



*Total Cost of Equipment*

63

12 bowls, brown .....	\$0.85	1 butcher knife .....	\$0.30
12 bread tins .....	.95	1 French knife .....	.60
12 teacups and saucers.....	1.25	2 spatulas .....	.80
12 tin measuring cups.....	1.25	6 teaspoons .....	.10
12 egg beaters .....	.30	3 tablespoons .....	.13
12 forks .....	.50	4 brushes .....	.20
12 case knives .....	1.25	2 stove mitts .....	.50
12 paring knives .....	1.25	4 asbestos mats .....	.20
12 plates .....	.85	1 corkscrew .....	.25
12 saucepans .....	1.68	4 egg beaters .....	.60
12 tablespoons .....	.50	4 wash basins .....	.92
24 teaspoons .....	.40	3 draining pans .....	.69
12 wooden spoons .....	.60	4 dishpans .....	2.00
12 stewpans .....	2.40	6 broilers .....	.48
12 strainers .....	.65	3 cake tins .....	.35
2 trays .....	.80	4 graters .....	.40
1 bowl, yellow .....	.25	3 strainers .....	.75
1 bowl, " .....	.35	24 pattie pans .....	.20
1 bowl, " .....	.45	2 tin dippers .....	.40
3 scissors .....	1.50	2 fiber pails .....	.70
5 trestle tables .....	20.55	1 colander .....	.35
6 frying pans.....	.90	1 pail, enamel .....	.70
3 tea strainers .....	.15	1 pan, enamel .....	.18
3 match-box stands .....	.24	3 tea kettles .....	2.70
1 emery knife .....	.20	1 saucepan .....	.30
3 soap dishes .....	.25	1 saucepan .....	.25
12 pepper shakers .....	1.50	1 saucepan .....	.23
12 salt shakers .....	1.50	1 saucepan .....	.30
1 bell .....	.50	1 double boiler .....	.85
4 lemon reamers .....	.40	1 kettle, covered .....	.60
6 stoves, kerosene .....	6.00	*1 stove (to burn coal or wood) .....	30.00
12 plates, dinner .....	1.25		
6 plates, soup .....	.60		
4 jugs .....	.60		
1 jug .....	.45		
		Total .....	\$100.05

The whole equipment is attractive, and is capable of modifications which will adapt it to the conditions of many schools. The Ontario Educational Department offers generous assistance to the schools which teach domestic science, and it is hoped this equipment will encourage the spread of domestic science teaching from the cities and towns to the village and rural schools.

\*The above may be replaced by a twenty-dollar wood stove or a ten-dollar two-burner coal oil stove.

EQUIPMENT OF SPEYER SCHOOL (PRACTICE SCHOOL OF TEACHERS  
COLLEGE, COLUMBIA UNIVERSITY)

Cooking table with drawers for eighteen, eighteen individual stoves, two large stoves, utensils, and dining room furniture (sink not included). Equipped, year 1902-03.

Cooking tables .....	\$150.00
Stoves (small) .....	13.50
Stools .....	13.50
Gas range .....	17.50
Coal range .....	13.50
Dining room .....	25.00
Refrigerator .....	10.00
Linen and china .....	10.00
Burners and tubing, etc. ....	5.00
Utensils .....	98.00
Incidentals .....	10.00
	<hr/>
	\$366.00
Plumbing connection .....	30.00
	<hr/>
	\$396.00

EQUIPMENT OF PUBLIC ELEMENTARY SCHOOL, JERSEY CITY, N. J.

24 oak tables with one drawer .....	\$175.00
24 gas stoves and one range .....	40.00
2 cupboards with shelves only .....	60.00
Utensils .....	125.00
	<hr/>
	\$400.00

Kitchen and dining room, now incomplete, will cost between \$700 and \$800.

EQUIPMENT OF A PUBLIC SCHOOL IN ONTARIO, CANADA

Furniture .....	\$274.00
Hardware .....	144.51
China, crockery, etc. ....	44.87
Napery, toweling, etc. ....	25.52
Clock .....	4.75
Contract for sink drain boards, gas and water piping, and gas stove fittings .....	137.00
	<hr/>
	\$630.65

BOSTON PUBLIC ELEMENTARY SCHOOLS

Specification of standard cooking room (Fig. 7). "Cooking room is to be fitted with a coal and wood box in two compartments, each about 24 inches square and 30 inches deep, with hinged lids; small shelf in one section. Provide work benches fitted with compartments for utensils, bread board, etc. Supply and set Bunsen burners with hinged grills over them on aluminum plates at each station, and connect up to the outlets left by gas fitter. The benches are to have tops of pine, open underneath and supported on pipe standard. One section of bench is to be detached and fitted as a demonstration bench."

An approximate estimate of cost of fitting up cooking room, as specified above, is as follows:

28 cooking stoves, hinged grill, aluminum plate arranged for each table, about \$8 each.....	\$224
1 stove, grill, aluminum plate teachers' table.....	12
Coal range, gas range, gas heater, soapstone sink, hot water boiler, plumbing, connections entire, about.....	400
Dresser, case, pupils' tables, demonstration table, pantry, wardrobe hooks, teachers' closet, wood box, zinc base under gas and coal range and lighting, about.....	1,200
	<hr/>
Total .....	\$1,836

The utensils for fitting up the school kitchens cost in the neighborhood of \$125, outside of the equipment.

ROCHESTER ATHENAEUM AND MECHANICS INSTITUTE

(Fig. 52)

Table: (1900-1901)

Lumber, screws, drawer, pulls, etc. ....	\$24.99
Iron bars and legs .....	9.99
Painting iron legs .....	3.30
Gas fittings .....	37.94
Burners—30 fixed Bunsen burners .....	20.00
Carpenter's time .....	40.13
	<hr/>
	\$136.35
1 cabinet Eclipse range, 4 burners, elevated baking, broiling and warming oven .....	40.00

1 Eclipse range, 16-inch square ovens.....	\$17.00
1 Red Cross Victor range, elevated closed warming oven and gas extension .....	46.00
1 porcelain sink, \$45, with 20% discount* .....	36.00
1 porcelain drain, \$22, with 20% discount*.....	17.60
Utensils in 17 drawers @ \$2.47 (see detailed list below).....	41.99
17 stools @ 60c .....	10.20
2 kitchen tables @ \$1.65 .....	3.30
1 garbage can, white enamel, covered .....	1.94
China closet with glass doors, 3 sections. Lower sections, two closets with doors and one section with 5 drawers.....	27.20
Pantry closets, 4 sections. Upper sections with sliding glass doors; lower sections, counter top, closets with door.....	53.80
	<hr/>
	\$431.38

*Cost in Detail of Utensils in Drawers*

## One Utensil for Each Student

Tablespoon (single plate), \$3.75 per doz. ....	\$0.31
Teaspoon (single plate), \$1.90 per doz. ....	.16
Fork, aluminum, \$1.25 per doz. ....	.10
Fork, steel, \$1.35 per doz. ....	.12
Knife, case, \$1.35 per doz. ....	.12
Knife, palette .....	.30
Knife, paring .....	.10
Wooden spoon .....	.08
Salt shaker, tin .....	.04
Pepper shaker, tin .....	.03
Flour shaker, tin .....	.05
Wire egg whip (Daisy) .....	.05
Working plate, a tin pie plate .....	.04
Bowl, earthenware, 1 qt. ....	.07
Custard cup, earthenware, @ 70c per doz. ....	.06
Strainer, wire .....	.05
Saucepan, enameled ware, 1 qt. ....	.27
Measuring cup, fourths (tin) .....	.05
Measuring cup, thirds (tin) .....	.05
Asbestos mat, 2 for 5c .....	.025
Vegetable brush, 55c per doz. ....	.045
Dishpan, tin, 10 qt., \$3.50 per doz. ....	.29
Linoleum square, 18 in. x 18 in. @ 15c, and metal eyelet @ 4c ....	.19
	<hr/>
	\$2.60

\*Does not include plumber's time or fittings.

## Total Cost of Equipment

67

### One Utensil for Each Two Students

Dover egg beater .....	\$0.10
Scrub brush, fiber, \$1.10 per doz. ....	.09
Soap dish, ironstone china .....	.10
	\$0.29
Total, one utensil for each student.....	\$2.60
Total, one utensil for each two students ( $\frac{1}{2}$ ) .....	.145
	\$2.745
Less 10% discount given by local stores .....	.274
	\$2.471

### MACDONALD INSTITUTE, GUELPH, CANADA

(Fig. 54)

Class table—hollow square, accommodates 24, top is white wood, aluminum strip under gas burners .....	\$241.00
25 folding chairs .....	31.25
Glass door cupboards .....	48.00
Sink cupboard .....	33.00
Teacher's table—6 drawers, 1 cupboard, with white wood top like class table .....	28.00
Supply table—oak frame, white wood top .....	15.00
Refrigerator .....	30.00
Stoves and small equipment .....	208.75
	\$635.00

Cost of porcelain sinks, gas stove fittings, and plumbing is not included above, as they were part of the building contract.

### UNIVERSITY OF ILLINOIS

#### *Kitchen Equipment* (Fig. 55).

1 refrigerator .....	\$60.00
4 tables, Alberine top @ \$70 .....	280.00
2 porcelain sinks @ \$65, with all plumbing .....	130.00
2 cupboards, each 5 ft. long @ \$8 per linear foot .....	80.00
1 gas range .....	38.00
1 experimental oven .....	150.00
16 Bunsen burners @ 25c .....	4.00
6 scales .....	36.00

7 microscopes (used both for kitchen and chemical laboratory) ..	\$266.51
Thermometers .....	
1 supply table .....	6.00
1 table, zinc top .....	2.00
Individual drawer equipment (16 @ \$3.65) .....	58.40
	<hr/>
	\$1,110.91

*Laboratory Equipment (Fig. 56).*

3 laboratory tables @ \$165 complete, plumbing, etc.....	\$495.00
1 hood .....	110.25
1 analytical balance .....	60.00
1 warming closet .....	25.00
1 sterilizing oven .....	10.00
1 incubator .....	91.80
	<hr/>
	\$792.05

## OTHER ESTIMATES WITHOUT DETAILS

Public Elementary Atypical School, Washington, D. C.....	\$400.00
Public Elementary School, Los Angeles, Cal.....	600.00
Public Elementary School, Philadelphia, Pa.....	about 1,200.00
Public Elementary School, Seattle, Wash.....	604.00
Public High School, Brookline, Mass. (Fig. 47) (1895).....	500.00
Public High School, Los Angeles, Cal.....	600.00
Public High School, New York City.....	940.00
Public High School, Seattle, Wash.....	644.00
Manual High Schools, Washington, D. C.....	2,000.00
Public High School, James Yeatman, St. Louis, Mo. (Fig. 50) ..	2,796.33

## CHAPTER VII

### COST OF MAINTENANCE

THIS depends upon the amount of work required of the pupils ; and it is largely within the control of the teacher to economize and still have all supplies sufficient. Supplies in the elementary school cost, as a rule, less than in the high schools ; in the normal school or college the expenditure is usually larger.

It is necessary for two reasons to make expenditures low ; in the first place to make it possible for the school board to introduce and maintain the work, and in the second place to teach economy in the use of materials to the pupils.

Work in cookery costs more than in the other branches of domestic science work, and perhaps the supplies are more per capita than for any other work in the school ; yet while practicing economy, domestic science teachers should contend against an appropriation so limited that the work is actually crippled. Where funds are very low pupils are obliged to work altogether in groups, and thus miss the opportunity for individual training, or, if the work is individual, the quantities are always too small to give actual practical training. The best laboratory methods include both individual and group work. Two to three cents per capita per lesson for elementary-school work is the minimum. In the high school, three to four cents per capita per lesson is a good allowance. In the college from \$7.50 to \$10 per year per student will allow for six hours' laboratory work per week for thirty weeks plus.

In general, the cost of food material may be kept within reasonable limits (1) by economic methods of purchase ; (2) by class management ; (3) by commercial schemes.

(1) Rules for economic buying apply here as elsewhere. Non-perishable materials cost less when bought in large quantities, either at wholesale rates or with the percentage off that is allowed

by retail dealers when quantities are sufficient to make it profitable. Perishable articles should be bought from reliable dealers, who will also allow percentage if the amounts warrant it. In institutions where there is a dormitory, or in schools where there is a lunch room, some coöperation in purchase makes for economy. Of course this is not possible in all places, especially in the public-school system of our large cities; but in each situation careful planning for the buying must certainly tend to reduce expenses.

(2) Class Management. In order to keep down the cost, the following two plans are in general use. Where individual work is given, each child handles the least possible quantity. In certain schools, for instance, the pupil will make only one muffin, say, or one baking powder biscuit. The second method is to allow the children to work in groups upon one dish, the group varying from one to three or four. Each of these methods has its defects. In the first, the pupils lack all opportunity for dealing with the normal quantity as used in the family, and in some processes fail to develop proper methods of manipulation on this account. The chief defect of the second method is that the child never has full responsibility from beginning to end for any one article. Either of these methods will reduce the cost to two cents per capita per lesson. This fact is evident from studying the statistics appended. In the Chicago schools the individual method is largely used; in the New York public schools, the group. If either of these methods alone can reduce the cost to two cents per capita, surely some wise combination of the two might have the same result. It is in the batter work, for instance, that small quantities give the pupil little opportunity to develop skill; yet a normal quantity is costly. Therefore, here it might be wise to have one or two lessons of the individual type, and others of the group type.

(3) There are several ways in which this financial burden may be lightened to the school. In many of our training schools and colleges a laboratory fee is paid by the students. But it is in the use of some commercial plan that the best solution of this difficult problem may be found. By commercial is meant some plan which involves the selling of the cooked products, either in a lunch room or to individuals. It is interesting to note that varied forms of this



method are already in existence in different parts of this country. In addition to the fact that by selling products the appropriation is increased, there are two strong arguments in favor of this plan: in the first place, it gives the pupil opportunity to work with normal quantities, which is certainly most desirable; and in the second, it familiarizes her in a practical way with the cost of food materials and with the market value of her labor.

The following reports are from schools where such methods are in use:

Miss Annie L. Bennet, director of the School of Practical Arts, Boston, Mass., writes in 1909: "We are allowed a monthly sum which averages one cent a lesson per pupil. This allowance would not purchase supplies sufficient to enable the pupils to do individual cooking and to prepare meals. The problems of utilizing perishable products and providing for a school luncheon were before us, and we decided to utilize the products of the cooking lessons for the school lunch. The girls of the domestic science class take charge, with helpers from the other classes, in arranging and selling the food. The proceeds are used for the purchase of supplies. By this method we increase our allowance, so that girls are able to cook larger quantities and have more individual responsibility. As a further help we have been able to secure trade discounts at the stores."

System worked out for the Hebrew Technical School for Girls, New York City, by Miss Birdseye and Miss Cumstock, under Miss Anna Hedges, director. This plan reduces the outlay to the school to \$0.0312 per pupil per month. Miss Birdseye wrote in 1909: "For the past eighteen months we have daily prepared and served luncheons, varying from sixteen to twenty-five in number, for the teachers of our school. The price of these luncheons is fifteen cents a meal, and is intended to cover simply the cost of material used and of breakage. The luncheons are prepared, during the last 45-minute period of the morning, by the manual senior class, under the supervision of a cooking teacher. This class, numbering about twenty students, can therefore get the equivalent of two and one-half double periods of cooking a week without expense

to the school. To the actual cooking of meals is often added experience in planning the luncheons and in marketing. It is possible also, as often as the nature of the weekly lesson allows, to dispose of the whole or a part of the cost of the material used. This arrangement results not only in materially reducing expense to the school, but, what is still more important, in enabling the pupils to work with fairly large quantities. We also, when cooking cake, bread, preserves, etc., in large quantities, dispose of our surplus to teachers, pupils, or friends of the school, among whom we always find a ready market."

Miss Mary Urie Watson, of Macdonald Institute, Guelph, Ontario, writes: "The revenue from the sale of food cooked in the Home Economics classes amounted to \$64.75 in 1907, which, of course, lessens the net cost of food stuffs, fuel, etc. The cost of food stuffs for class use is considerably lightened by the use of Macdonald Hall materials whenever the dishes which the teacher wishes to have the class study and make are suitable for the next meal in the Hall. The housekeeper of the Hall coöperates heartily in this."

A list is appended of estimates of cost of materials collected from a number of elementary and high schools in 1908-09. These estimates to be thoroughly intelligible should be accompanied by the courses of study, but space does not permit.

Boston Public Elementary School.....	per capita per lesson	\$0.023
Public Elementary School, Chicago, Ill.....	" "	.02
Public Elementary School, Los Angeles, Cal.,	" "	.021
Public Elementary School, Minneapolis, Minn.,	" "	.02
Public Elementary School, Newark, N. J.....	" "	.02
Public Elementary School, New York.....	" "	.02
Public Elementary School, Philadelphia, Pa...	" "	.02
Public Elementary School, St. Louis, Mo.....	" "	.02
Public Elementary School, Washington, D. C.,	" "	.02
Boston Public High School of Practical Arts,		
allowed .....	" "	.01
Public High School, Los Angeles, Cal.....	" "	.021
High School Classes, Macdonald Institute,		
Guelph, Canada .....	" "	.027

Public High School, St. Louis, Mo.....per capita per lesson	\$0.02
Public High School, Washington, D. C.....	“ “ .02
Public High School, Brookline, Mass., provisions per year, about eighty pupils .....	250.00

The average cost of materials as reported from a few colleges is per student per year, six hours a week for thirty to thirty-six weeks, \$7.50 to \$10.

Another expense is the cleansing of the laboratories. In most of our schools it is not possible to have paid service, and therefore most of the cleansing has to be done by the pupils in conjunction with the janitor; but here, again, it is sometimes necessary for the teacher to insist that something be allowed her, at least occasionally, for the services of a trained worker.

The question of laundering towels is a difficult one. In a school kitchen, if the schedule allows time enough, the children can wash the towels daily; but in addition to this the towels need to be sent out once in a while to be thoroughly laundered. If there is a laundry in the building, of course the work may be done there. In many schools there is not time enough for the pupils to complete their work in cooking and also to wash the towels properly; this, then, becomes quite an item of expense. The following item shows how much this means in the budget. Towels for about 300 students per week, thirty weeks, \$200.

Very few estimates have been obtained for the annual breakage and wear. At Teachers College, Columbia University, in three cooking and two dining rooms, including the college rooms and the Speyer School, used weekly by some 400 students, including children, the cost has been estimated for the years 1906-07, 1907-08, as follows: Breakage, \$25; replacing towels, \$30.

Very little information has been collected as yet in regard to the total cost of maintenance of a large department of domestic science. This total would include teachers' salaries. One well-equipped department belonging to a Western university reports \$16,000 as the total for the year.

## CHAPTER VIII

### PORTABLE EQUIPMENT FOR LECTURES

At the present time the teacher of Domestic Science, either in public school work or in college, is called upon to give some form of public lecture. This may be before a Woman's Club, a Mothers' Club, a Farmers' Institute or Grange. In some states the attempt has been made to arouse public interest by sending a teacher or group of teachers in a car equipped for Domestic Science lectures. This is one means of enlarging the work, and all teachers should be ready to respond to this demand. The following suggestions have been contributed to this volume by Miss Anna Barrows, well known as a successful worker in the extension field.

#### PORTABLE EQUIPMENT FOR DEMONSTRATION LECTURE

The teacher of Domestic Science who does itinerant work, whether before women's clubs or at agricultural meetings, gradually eliminates the unnecessary and selects the most helpful articles for her equipment. To be sure that the outfit is at the right place on time, it should be packed in a case which the teacher herself can carry. Baskets or straw cases admit dust and break easily, hence are unsuitable for long journeys. Leather suit cases are too heavy. Certain fiber preparations are quite satisfactory, such as are used extensively by commercial travelers. An extension case of this type about 15 x 20 inches weighs three and one-half pounds. It requires a strong shawl strap with an easy handle, and then may contain good-sized utensils. Sometimes a smaller sized case is sufficient.

Stove, dishpan, water and garbage pails, and dishes for serving may be provided at the place where the lecture is to be given.

Fortunate is the teacher where a gas stove is available, but this is rare in small towns; and kerosene, gasoline, and alcohol do excellent work.

A traveling chafing dish, the inverted standard of which may be packed in the pans, takes up little space. Other chafing dishes are often loaned by members of a woman's club.

A simple alcohol lamp is to be preferred for farmers' institutes, since the chafing dish sometimes is looked upon as a fad rather than a really helpful utensil.

Some lecturers have preferred to send a list of needed utensils to be provided by the committee in charge; but names of articles may be misunderstood, or the right utensil cannot be found in town.

Work can be done with greater ease when utensils and recipes fit each other. A lecture proceeds more smoothly when a teacher selects her own tools.

The essential articles for a single demonstration lecture are those with which nine-tenths of the food for an average family is prepared. The difference is in size and weight rather than in the purpose of the tool.

The usual single school desk equipment is a fair supply, plus any special utensil required by the particular foods to be demonstrated.

#### PORTABLE EQUIPMENT FOR DEMONSTRATION LECTURES

Suitable for single demonstration, with simple work.

Alcohol lamp	Saucepan, $\frac{1}{2}$ pint
Paring knife	Bowl, 1 quart
Case knife	Bowl, 1 pint
Palette knife	Plates
Fork	Measuring cup, glass
Tablespoon	Measuring cup, tin
Teaspoons	Pudding pans
Wooden spoon	4 or 6 enamel cups
Can opener	Pastry brush
Egg beaters (Dover, wire)	Strainer, small, fine
Grater	Strainer, larger, coarse
Omelet pan	Scrubbing brush, small
Saucepan, 1 pint	Small rolling pin

The choice of the utensils shown in Figs. 58 and 59 has been an evolution, and it varies according to the subject of the lecture.

The special aim has been to secure light utensils, well made, easy to keep clean; just the points every housekeeper should consider in furnishing her own kitchen.

The utensils are selected to fit into each other and to occupy as little space as possible. Each article is wrapped in soft paper to prevent needless defacement in the hands of the baggage man, or when the bag bounces out of the carriage on the hard, frozen ground, as has happened.

In the picture (Fig. 58) the plates are on edge, but when packed they fit under the saucepans and bowls. The board, though small, adds to the weight and is not essential. Strong, smooth paper will usually serve the same purpose.

The contents as here described were used for a series of demonstrations before farmers' institutes, only one or two lectures being given in each place. The tiny alcohol lamp was supplanted by the coal or wood heater, or in some cases by a gasoline stove.

Among the dishes prepared were omelets, white sauce, cheese fondu, salmon loaf, beef cutlets, brown gravy, potato soup, custards, dumplings, etc.

Often when there was not time for a cooking lecture, this bag and its contents have been the basis of a talk on helpful utensils. Many women, especially in old country houses, continue to use the appliances of past generations.

As Mrs. Kedzie has said: "Kitchen utensils cost less than coffins." No article here is too expensive for the average home. Yet there are wealthy households which lack some of these helpful tools.

Bowls and pans of agate, aluminum, or enamel wear may be used like saucepans directly over the flame, or the larger set over a smaller holding water, like a double boiler. Tin or aluminum plates to fit may serve as covers for such pans while potatoes boil and dough rises, and are also for baking the bread later.

By inverting a bowl over a deep frying pan and keeping water in the latter, it is possible to steam a meat loaf or a pud-

ding in a mold set on a trivet or some nails. Timbal or custard cups of enamel, aluminum, or tin will serve many purposes and their contents be cooked much sooner than if all were in a large mold.

The deep, oval, agate pudding dish below (Fig. 58), and beyond that the agate pan with rounding corners, are useful for many purposes and easy to wash.

Two measuring cups are included. The glass one is an exception to the safe rule of taking nothing breakable, but wrapped in a towel and placed in a bowl will travel safely.

Incidentals usually included in the contents of the case are matches, paper towels, napkins, plates and ice cream spoons, cheesecloth, soap, sand soap, dish towels, holders, two aprons. Tiny tin boxes saved from samples of cocoa, etc., hold small quantities of salt, pepper, paprika, soda, baking powder, spices, herbs, etc., of which only small quantities are needed. A few larger one-half pound boxes may contain flour, dry crumbs, etc.

Though denatured alcohol may be procured almost everywhere, still it is wise to provide some in advance. A pint bottle may be wrapped in a towel and packed in a tin cracker box.

A trunk is needed where six or eight lectures are to be given in one hall or where all meetings are on railroad routes, but not where stages or trolleys provide means of conveyance.

A half trunk or steamer trunk is often sufficient. Unless an exceedingly good one is chosen, the weight of the contents will soon shatter the trays, but these may be reënforced, and an inexpensive trunk will make many trips.

One shallow tray will carry the white dress, aprons, towels, holders, etc. A deeper one will contain the choicer utensils, books, charts, etc. The lower portion of the trunk may be subdivided further, if desirable, by strong pasteboard boxes.

Forethought in choice of utensils will also result in saving some space for charts, books, United States Department of Agriculture bulletins, and other illustrative material. These are as essential for the itinerant teacher as the tools for cookery.

The most satisfactory charts are those made on cloth, because these may be folded and packed in small space. Charts on wooden rollers are most inconvenient.

Lectures on human foods and other lines of home economics will secure a place on the program of educational meetings more often when the teachers make greater use of the blackboard and charts, and cease to try to give lessons suitable only in well-equipped cooking schools.

The railway car is coming to the front as an itinerant school-house, and a few have been fitted for home economics lectures. Usually these are a part of the trains sent out from the agricultural colleges, and some space is given to exhibits of work done by the students. The walls afford space for charts, books, and models which cannot be damaged by the motion of the train. A blackboard is an essential part of the equipment. Otherwise the outfit already described will serve the purpose of the teacher who is to give demonstration lectures in the car.



# ILLUSTRATIONS OF EQUIPMENT



Fig. 28. Table setting laboratory, School of Household Arts, Teachers College, Columbia University



Fig. 29. Cooking laboratory, School of Household Arts, Teachers College, Columbia University



Fig. 30. Commercial cupboard



Fig. 31. Portable laundry equipment in use in Teachers College, old building

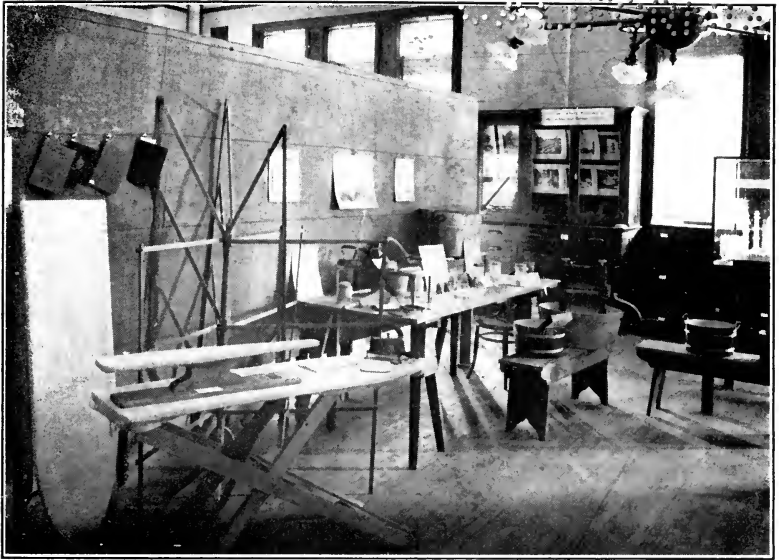

Fig. 32. Portable laundry equipment exhibit, 1904, Domestic Science Department, Teachers College, Columbia University

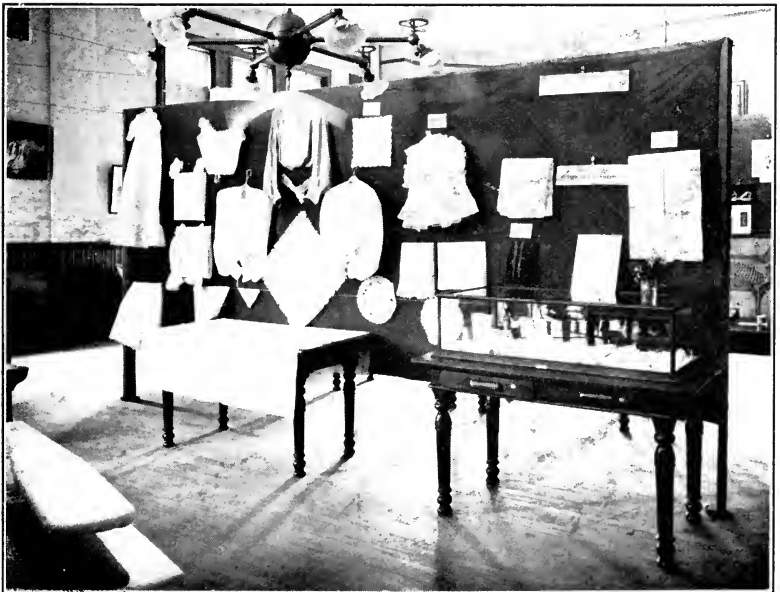

Fig. 33. Exhibit of laundry work, 1904, Domestic Science Department, Teachers College, Columbia University



Fig. 34. Laundry work, New York City public schools



Fig. 35. Domestic Science laundry work, New York City public schools



Fig. 36. Laundry classroom, Macdonald Institute, Guelph, Canada



Fig. 37. Dining table, University of Nebraska, temporary building



Fig. 38. Dining room, Mechanics Institute, Rochester, N. Y.



Fig. 39. Dining room, University of Illinois



Fig. 40. Packing box equipment, Teachers College, Columbia University

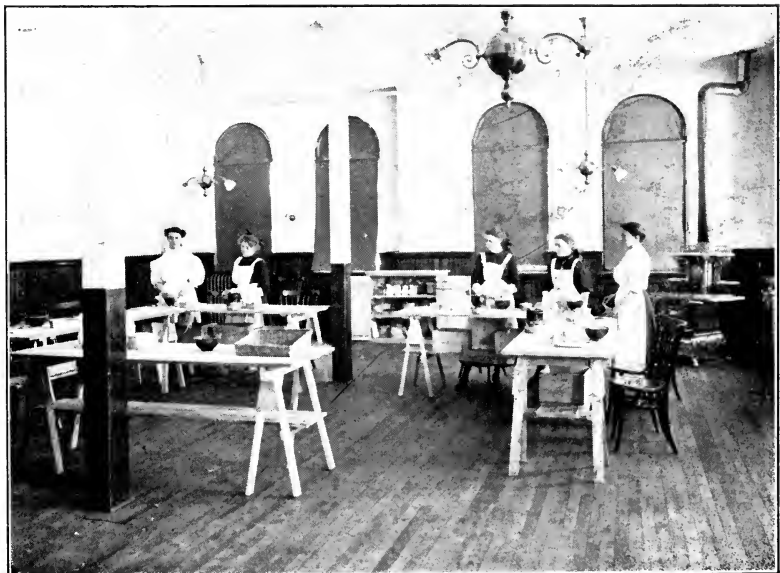

Fig. 41. Portable equipment for district schools, Macdonald Institute, Guelph, Canada. Boards on horses



Fig. 42. Portable equipment for district schools, Macdonald Institute, Guelph, Canada. Boards on schoolroom desks

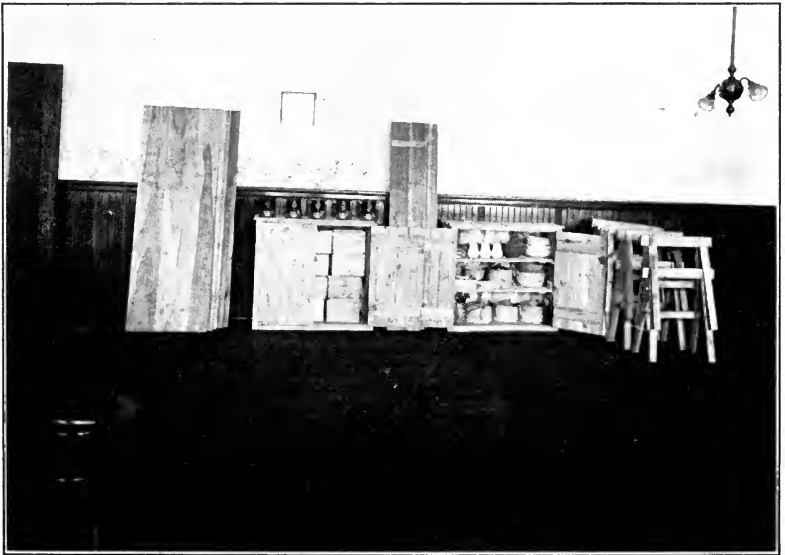

Fig. 43. Stored portable equipment for district schools, Macdonald Institute, Guelph, Canada





Fig. 44. Equipment in Elementary Public School, Washington, D. C.



Fig. 45. Ogden Cooking School, State Normal School, Athens, Ga.



Fig. 46. Kitchen remodeled from classroom, Tenafly, N. J.



Fig. 47. Brookline High School, Brookline, Mass.



Fig. 48. Cooking room, Public School 21, Manhattan, New York City



Fig. 49. Cooking room, Technical High School, Cleveland, Ohio

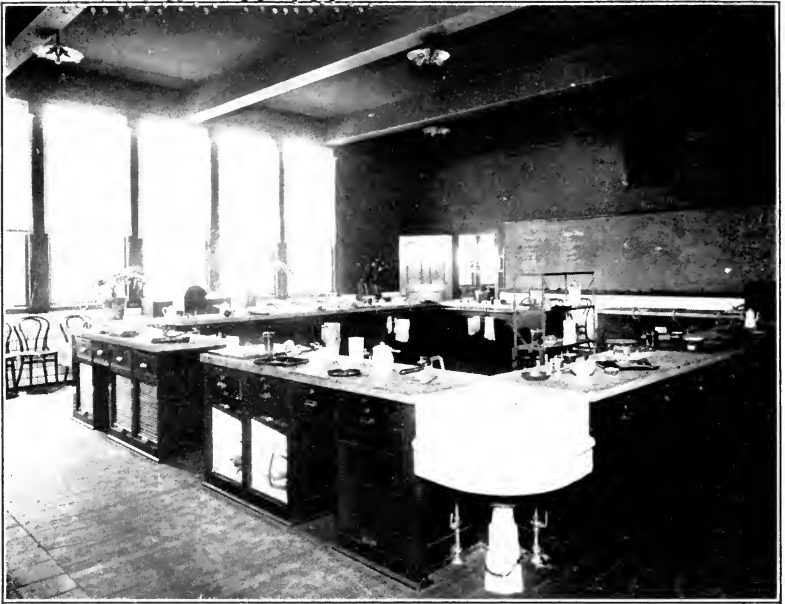

Fig. 50. Domestic Science room, James E. Yeatman High School, St. Louis, Mo. William B. Ittner, architect

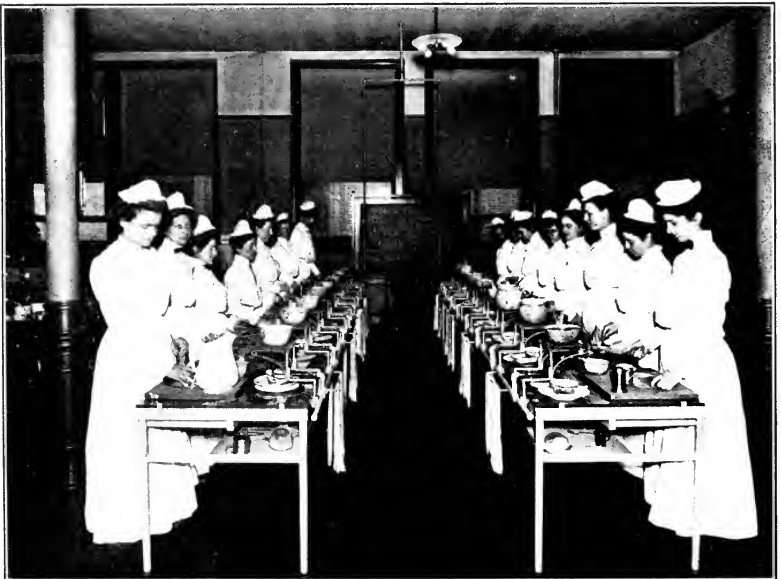

Fig. 51. Kitchen, Drexel Institute, Philadelphia, Pa.

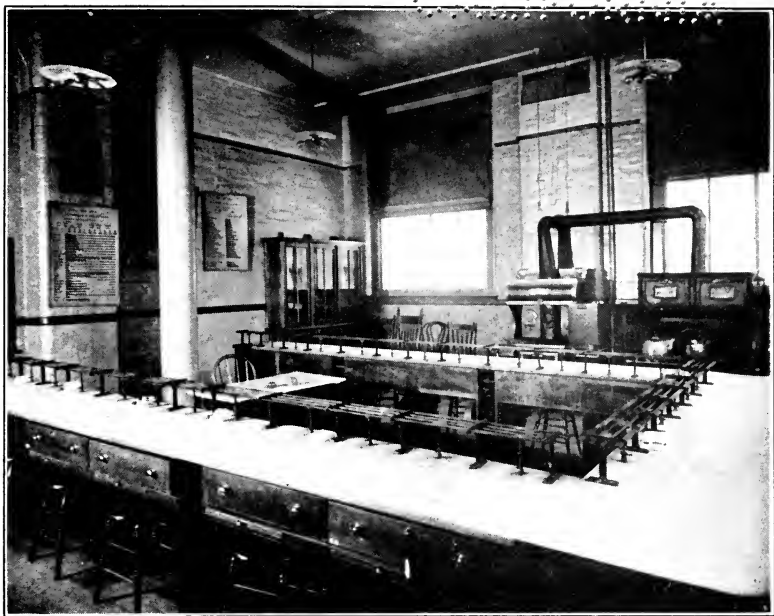

Fig. 52. Kitchen, Mechanics Institute, Rochester, N. Y.

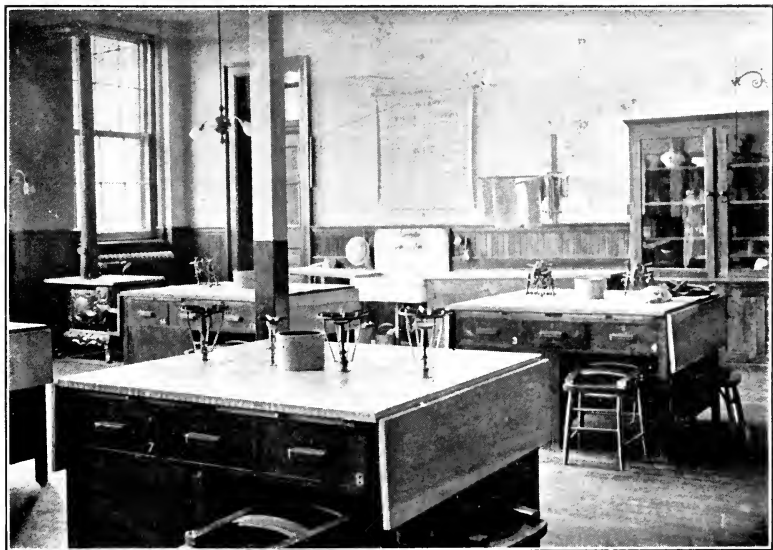

Fig. 53. Practice kitchen, Macdonald Institute, Guelph, Canada



Fig. 54. Kitchen, Macdonald Institute, Guelph, Canada



Fig. 55. Kitchen, Department of Household Science, University of Illinois



Fig. 56. Food laboratory, University of Illinois



Fig. 57. Portable equipment for demonstration, Domestic Science Department, Teachers College, Columbia University



Fig. 58. Portable equipment used by Miss Anna Barrows



Fig. 59. Portable equipment used by Miss Anna Barrows



INDEX

- Agriculture, Department of, 44  
 Aladdin oven, 30  
 Apparatus for scientific experiment,  
 43, 44, 68  
 Atkinson cooker, 28  
 Boardman School, 53  
 Boston, Public Elementary School,  
 14, 65, 72; High School of  
 Practical Arts, 71  
 Brookline Public High School, 68,  
 73, 88  
 Bunsen burners, 32, 33, 35, 64, 65, 67  
 Carnegie Food Laboratory, 26  
 Carnegie Technical School, 20  
 Charts, 44, 45  
 Cooking laboratory, 13-46, 79, 89,  
 90, 93  
 Chicago Public Elementary School,  
 72  
 Cupboards. See *Shelves* and *Work  
 Tables*  
 Cleveland Technical High School,  
 33  
 Coal stoves, 29; cost of, 28, 29, 64,  
 65, 66  
 Continuous rack, 33-34, 35, 91; cost  
 of, 35, 65  
 Cost of maintenance of domestic  
 science work, 69-73; per cap-  
 ita, 69; plans for decreasing,  
 70-73  
 Denatured alcohol stoves, 30  
 Departmental coöperation, 47, 48  
 Dining room, 47-48, 49, 64, 79, 83,  
 84  
 Domestic art work, 6, 7, 15, 47  
 Drexel Institute, 10, 18, 21, 90  
 Electric attachments for stoves, 28,  
 30  
 Estimated cost of equipments, 60-68  
 Equipment, 2-4; care of, 57, 58;  
 inventory of, 58; purchase of,  
 57; storing of, 58. See *Cook-  
 ing laboratory*, *Dining room*,  
*Estimated cost of equipment*,  
*Home nursing*, *Housekeeping*,  
*Laundry*, *Table setting*, *Uten-  
 sils*  
 Evanston Public Schools, 3  
 Fireless cooker, 28, 30  
 Floor finish. See *Rooms*  
 Gas stoves, 29; cost of, 29, 30, 64,  
 65, 67  
 Hartford High School, 32, 33  
 Hebrew Technical School, 71  
 Home nursing, 55; equipment for,  
 55, 56  
 Hot plates, 31-32, 33, 89  
 Housekeeping, 58; equipment for,  
 43. See *Rooms*  
 Illustrative material. See *Charts*  
 and *Specimens*  
 Individual stoves, 30; single gas,  
 30-32, 33  
 James Yeatman Public High School,  
 68, 90  
 Jersey City Elementary School, 64  
 Kerosene stoves, 28, 30  
 Laundry work, 49, 50, 82, 83; port-  
 able equipment for, 50-52, 53,  
 85, 86; stationary equipment for,  
 53, 54  
 Lillian Massey School, 21  
 Linen, 64  
 Los Angeles, Public Elementary  
 School, 68, 72; Public High  
 School, 68, 72

- Macdonald College, 6, 37, 54, 72, 83, 91, 92; rural school equipment of, 62-63, 67, 85, 86
- Mechanics Institute, 34, 35, 65, 84, 91
- Minneapolis Public Elementary School, 72
- Newark Public Elementary School, 72
- New York Public Schools, 68, 72, 82, 89
- Ogden Cooking School, 87
- Ontario Public School, 64
- Packing box equipment, 16, 37, 61, 62, 85
- Philadelphia Public Elementary School, 68
- Plate warmer, 39
- Portable equipment, 80, 81, 85, 86, 93, 94. See *Laundry work*
- Pratt Institute, 49
- Refrigerators, 38, 64, 67
- Rooms for domestic science, chimneys and flues of, 8; floors of, 9, 10, 11; location and exposure of, 7; number of, 5; pipes and electric fittings of, 8, 64; shape and size of, 6; ventilation of, 7, 8; wall finish of, 8, 9, 12; windows and doors of, 8; woodwork of, 11, 12
- Rural school equipment, 62-63, 85, 86. See *Macdonald College*
- Saginaw Manual Training High School, 54
- School kitchens, models for, 8, 9, 10, 11, 12, 13, 14, 15, 59, 85, 90, 91, 92. See *Rooms*
- School of Household Arts, Teachers College, 6, 15, 20, 23, 31, 33, 44, 54
- School of Practical Arts, 71, 72
- Seats, 26; attached, 27, 28, 67; stools as, 26, 27, 64, 66
- Seattle Public Elementary School, 68; Public High School, 68
- Shelves, 36, 37, 80; cost of, 37, 65, 66
- Simmons College, 34, 35
- Sinks, 24, 25, 35; cost of, 26; material for, 36
- Specimens, 45
- Speyer School, 64, 73
- St. Louis, Public Elementary School, 72; Public High School, 73
- Stoves, 28; kinds of, 28, 29, 30-35; prices of, 29, 35, 64, 65, 67; sizes of, 29
- Supply tables, 38, 67, 66
- Tables. See *Work tables*
- Table setting, equipment for, 49, 79
- Tenafly Public School, 7, 88
- Toledo Manual Training High School, 30, 33
- Uniforms for students, 45; for teacher, 46
- University of Illinois, 6, 67, 84, 92, 93
- University of Nebraska, 6, 48
- University of Wisconsin, 43
- Utensils, 39; lists of, 40-42, 43, 61, 62, 63, 64, 65, 66, 67, 68; material for, 39, 40; sizes of, 40
- Wall finish. See *Rooms*
- Washington, Atypical school, 68
- Washington, Public Elementary School, 72, 87; Public High School, 68, 73
- Work tables, 14, 15, 16; double parallel, 18; fixed, 17; group, 18, 19, 36; movable, 16, 17; parallel, 17, 18, 35, 90; rectangular, 17, 18, 19, 35, 89, 90; single, in rows, 20; slanted, 17, 18, 19
- attachments for, 24; cost of, 26, 64, 65, 66, 67; cost of tops for, 26; materials for, 24, 25, 26; shelves, drawers, cupboards of, 19, 20-23, 24, 25, 27, 80, 90







THIS BOOK IS DUE ON \_\_\_\_\_  
STAMPED BELOW

**AN INITIAL FINE OF 25 CENTS**  
WILL BE ASSESSED FOR FAILURE TO RETURN  
THIS BOOK ON THE DATE DUE. THE PENALTY  
WILL INCREASE TO 50 CENTS ON THE FOURTH  
DAY AND TO \$1.00 ON THE SEVENTH DAY  
OVERDUE.

FEB 16 1934

NOV 24 1936

MAY 17 2004

LD 21-100m-7,'33

227626

TX165

K5

UNIVERSITY OF CALIFORNIA LIBRARY

