

*Agric. - Forestry*  
*Main Library*

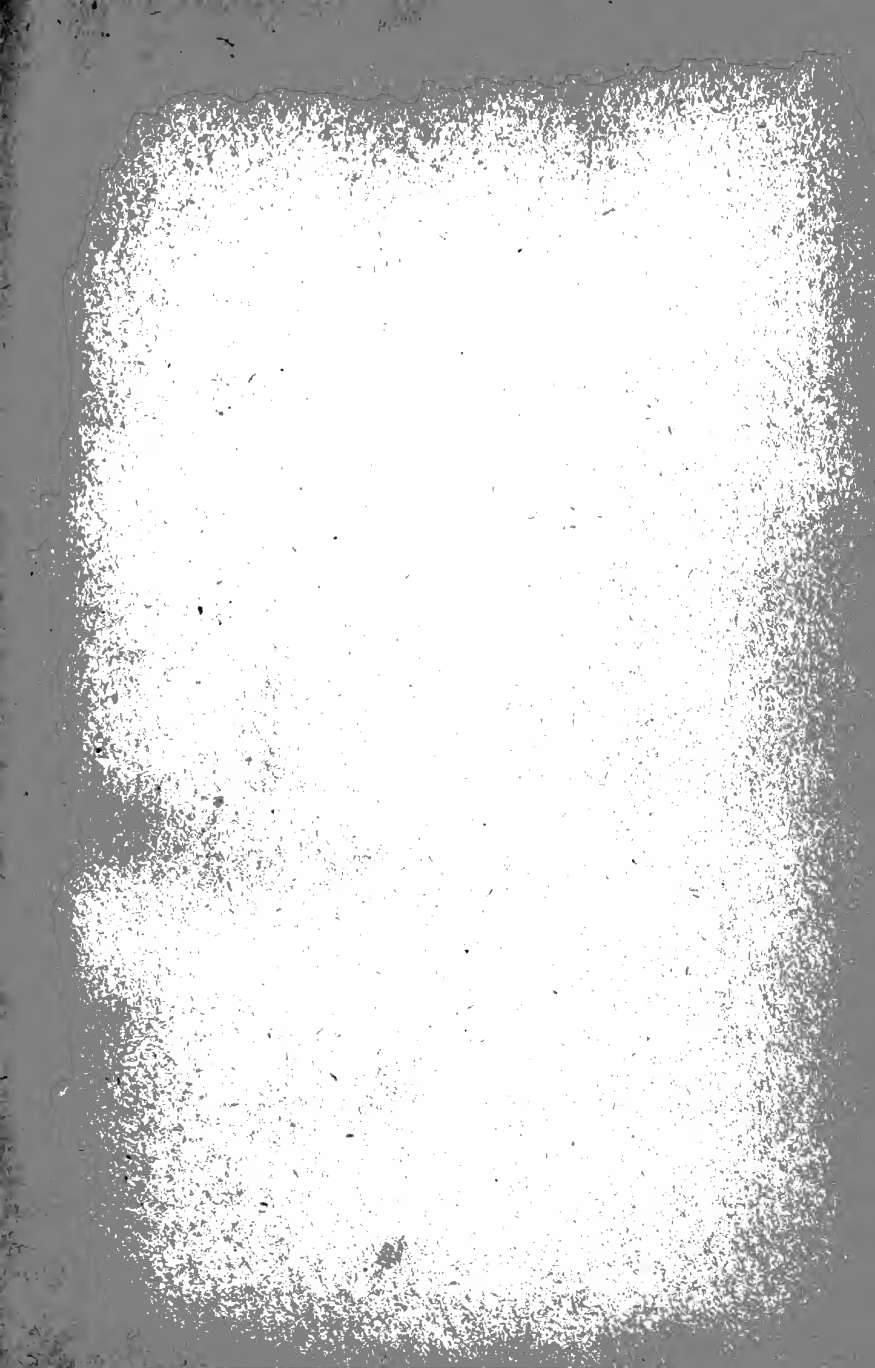

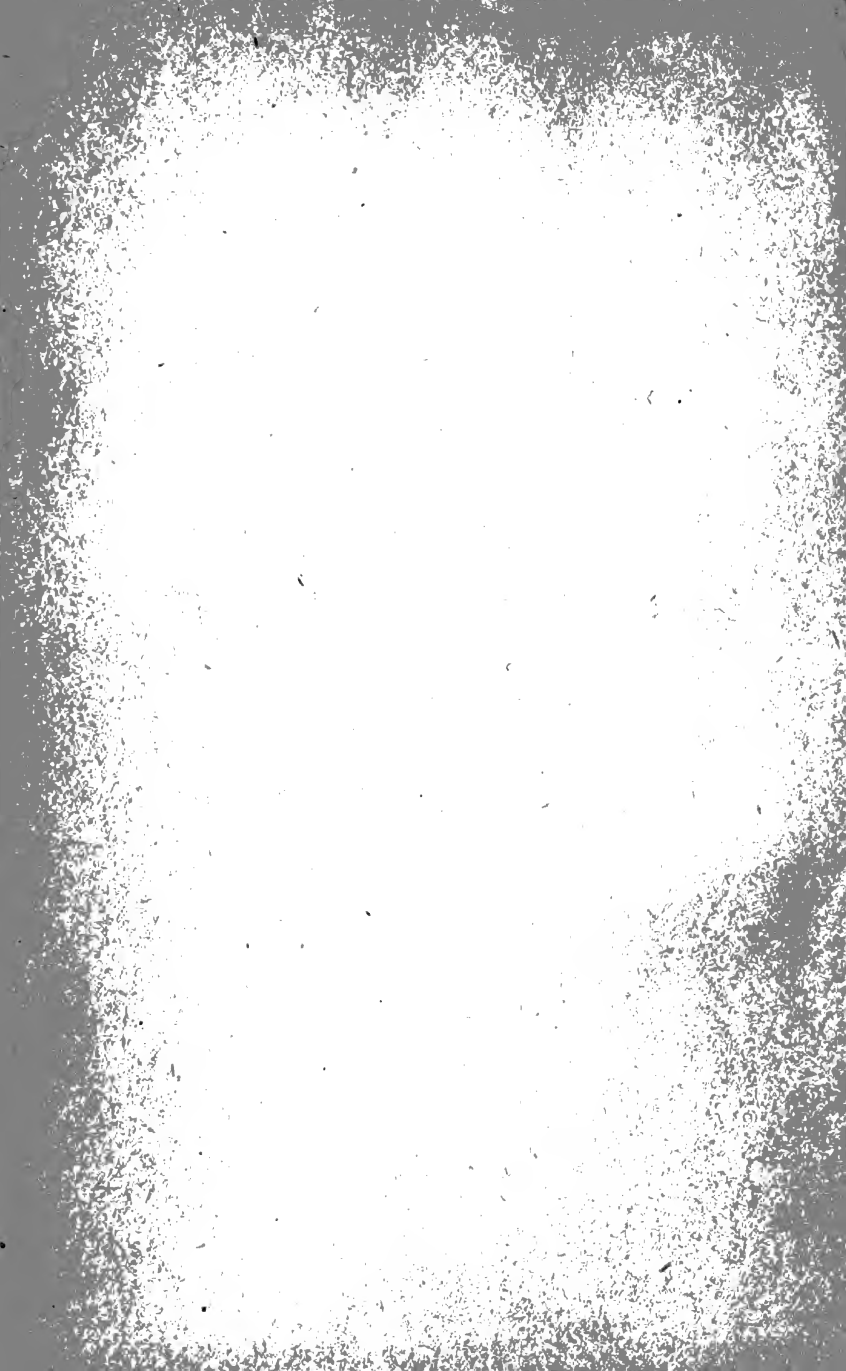



Digitized by the Internet Archive  
in 2007 with funding from  
Microsoft Corporation



### GAIUS FURIUS CRESIMUS,

a freedman, being able to raise from a bit of land far more abundant harvests than his neighbors could from the largest farms, was greatly envied, and accused of enticing away the crops of others by the practice of sorcery. . . . A day was appointed for his trial. Apprehensive of being condemned, when the question was to be put to vote among the tribes, he had all his implements of husbandry brought into the Forum, together with his farm servants, robust, and, as Piso says, well-conditioned and well-clad, iron tools splendidly made, stout mattocks, ponderous ploughshares, and sleek oxen. When all this had been done, he said, "These, Roman citizens, are my instruments of magic; nor can I exhibit to your view, or bring into the Forum, those midnight toils of mine, those early watchings, those sweats and fatigues." Upon this he was unanimously acquitted. — PLINY



# THE ESSENTIALS OF AGRICULTURE

BY

HENRY JACKSON WATERS

PRESIDENT OF THE KANSAS STATE AGRICULTURAL COLLEGE

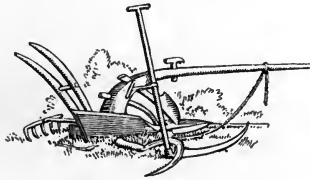

GINN AND COMPANY

BOSTON • NEW YORK • CHICAGO • LONDON  
ATLANTA • DALLAS • COLUMBUS • SAN FRANCISCO

5495  
W42

COPYRIGHT, 1915, BY  
HENRY JACKSON WATERS

ALL RIGHTS RESERVED

115.7

AGRIC. DEPT. - *5-10-15*

TO THE  
LIBRARY

**The Athenæum Press**  
GINN AND COMPANY • PROPRIETORS • BOSTON • U.S.A.

## PREFACE

The American people have definitely decided that the public schools shall teach pupils to think and to do ; that, so far as is consistent with a reasonably liberal culture, the training of the student shall relate intimately to the life he expects to lead.

For a century and a half agriculture has been regarded by a few of the foremost educators as worthy of a place in our public schools, but it is only within the last decade that the dream of these educators has approached realization. Agriculture, wherever well taught, has proved to be a source of strength to the school, whether a one-teacher country school, a high school, a college, or a university.

In no way is it possible for the school to serve the local community more successfully than through instruction in agriculture. This may be best accomplished through the utilization of the facilities of the neighborhood as a laboratory. The gardens, orchards, and farms, and, indeed, the gardeners and farmers themselves, should be utilized to the fullest extent. By this means the school and the community are brought into the closest relations, and there is awakened among the farmers a lively interest in the work of the school.

If the farmer is to support properly his own family and the two town families for whom he must provide food, he will need all the help that science can give. The way the two families in town will live is definitely related to the degree of skill with which the farmer tills his land and the degree of intelligence which the townspeople display in utilizing the farmer's products.

This book is for students who desire a practical working knowledge of the essentials of agriculture. The author has tried to present a clear statement of the principles underlying successful farm practice and to give a view of what the

comparatively new and world-wide interest in agriculture means. The arrangement of subject matter in this text is based upon the results of the best experience in teaching agriculture in secondary schools, and upon the courses of study adopted by various state departments of education. For schools presenting less than a year's course it is suggested that Chapters I-XVIII be studied first; then from the remaining chapters those should be selected which are most fundamental to the farm practices of the community.

Agriculture is too complex for all of its details to be mastered by one person. The expert in crops or soils does not possess more than a general knowledge of live stock, fruit growing, and dairying. In the subject of crops there are those who have specialized in grains, forage crops, or grasses. In animal husbandry there are specialists in beef cattle or dairy cattle, specialists in draft horses or light horses, and specialists in sheep or swine. If a man attempted to speak out of his own knowledge on all the phases of agriculture covered by a school text, the treatment of many of the subjects would be inaccurate and misleading, or else so general as to be of little value. To insure a work that is accurate in all its details the author has chosen for each branch of the subject an expert who is responsible in large part for the material in the field of his specialty. The author has organized this material into a logical, teachable work on agricultural science and practice.

To the help of the following specialists is due in large measure whatever merit the book possesses: M. F. Miller, Professor of Agronomy, University of Missouri (Soils); H. F. Roberts, Professor of Botany and Plant Breeding, Kansas State Agricultural College (Plant Breeding and Plant Feeding); H. D. Hughes, Professor of Agronomy, Iowa State College (Corn, Oats, Alfalfa, and Clover); Cecil Salmon, Assistant Professor of Farm Crops, Kansas State Agricultural College (Wheat); Carleton R. Ball, Crop Specialist, United States Department of Agriculture (Sorghums); W. R. Dodson, Director Louisiana Experiment Station (Cotton); Dr. J. C. Whitten, Professor of Horticulture, University

of Missouri (Orchards); Dr. W. L. Howard, Professor of Pomology, University of California (Plant Propagation); C. A. Scott, Professor of Forestry, Kansas State Agricultural College (Forestry); L. E. Call, Professor of Agronomy, Kansas State Agricultural College (Dry Farming); Dr. W. W. Garner, Physiologist in charge of Tobacco and Plant Nutrition Investigations, United States Department of Agriculture (Tobacco); George A. Dean, Professor of Entomology, Kansas State Agricultural College (Insect Pests); E. C. Johnson, State Leader, Kansas State Agricultural College (Plant Diseases); Albert Dickens, Professor of Horticulture, Kansas State Agricultural College (Spraying); J. M. Evvard, Live Stock Experimentalist, Iowa State College (Feeding Animals); E. A. Trowbridge, Professor of Animal Husbandry, University of Missouri (Horses and Mules); O. E. Reed, Professor of Dairy Husbandry, Kansas State Agricultural College (Dairy Cattle and Dairy Manufactures); H. P. Rusk, Beef Cattle Specialist, University of Illinois (Beef Cattle); T. H. Wright, Assistant Professor of Animal Husbandry, Kansas State Agricultural College (Swine and Sheep); W. A. Lippincott, Professor of Poultry Husbandry, Kansas State Agricultural College (Poultry); A. A. Potter, Dean of the Division of Engineering, Kansas State Agricultural College (Mechanical Power for the Farm); D. H. Doane, Professor of Farm Management, University of Missouri (Farm Management); and O. R. Johnson, Assistant Professor of Farm Management, University of Missouri (Farm Accounts).

For valuable suggestions regarding the adaptations of the principal crops to the particular regions with which the following men are most closely associated, acknowledgment is made to: Dr. Andrew M. Soule, President of the State College of Georgia; Dr. B. W. Killgore, Director of the North Carolina Department of Agriculture; Andrew Boss, Chief of the Division of Agronomy and Farm Management, University of Minnesota; J. F. Duggar, Director of the Agricultural Experiment Station of Alabama; F. W. Taylor, Professor of Agronomy of the New Hampshire Agricultural College; Dr. C. B. Hutchison,

Professor of Farm Crops, University of Missouri; C. A. Mooers, Chemist and Agronomist, University of Tennessee; A. H. Leidigh, Agronomist in Charge of Soils, Texas Agricultural College; C. B. Williams, Chief of Division of Agronomy, North Carolina Agricultural College; Dr. A. N. Hume, Agronomist, South Dakota State College; J. A. Foord, Professor of Farm Administration, Massachusetts Agricultural College; and C. F. Marbut, Director of the Soil Survey, United States Bureau of Soils.

The author also desires to express his profound gratitude to J. W. Searson, Professor of the English Language, of the Kansas State Agricultural College, for general advice and for assistance in the arrangement of subject matter, and to E. L. Holton, Professor of Education, H. L. Kent, Professor of Vocational Education, and J. H. Miller, Dean of the Extension Division, of the Kansas State Agricultural College, for helpful criticisms.

Especial acknowledgment is due Dr. Otis W. Caldwell, Dean of the University College and Professor of Botany in the School of Education of The University of Chicago and a recognized authority in matters pertaining to the teaching of science, for his constructive criticisms of the entire manuscript and for his invaluable assistance in editing and adapting the work to the needs of secondary schools.

HENRY JACKSON WATERS



# CONTENTS

CHAPTER	PAGE
I. THE NEW AGRICULTURE . . . . .	1
II. BETTER PLANTS AND ANIMALS . . . . .	8
III. HOW PLANTS FEED AND GROW . . . . .	23
IV. PLANT PROPAGATION . . . . .	35
V. THE SOIL AND ITS MANAGEMENT . . . . .	49
VI. THE PROPERTIES OF SOILS . . . . .	58
VII. PLANT FOOD IN THE SOIL . . . . .	72
VIII. MAINTAINING SOIL FERTILITY . . . . .	82
IX. BARNYARD MANURE . . . . .	91
X. COMMERCIAL FERTILIZERS . . . . .	101
XI. RELATION OF TYPE OF FARMING TO SOIL FERTILITY . . . . .	115
XII. DRAINAGE, IRRIGATION, AND DRY FARMING . . . . .	122
XIII. CORN . . . . .	134
XIV. THE SMALL GRAINS . . . . .	156
I. WHEAT . . . . .	156
II. OATS . . . . .	169
III. BARLEY . . . . .	171
IV. RYE . . . . .	172
V. RICE . . . . .	173
XV. FIBER CROPS . . . . .	177
I. COTTON . . . . .	177
II. FLAX . . . . .	187
III. HEMP . . . . .	188
XVI. GRASSES . . . . .	192
XVII. LEGUMES . . . . .	204
I. GENERAL STATEMENT . . . . .	204
II. RED CLOVER . . . . .	207
III. ALFALFA . . . . .	210
IV. OTHER LEGUMES . . . . .	216
XVIII. FORAGE CROPS . . . . .	223
XIX. ROOTS AND TUBERS . . . . .	231

CHAPTER	PAGE
XX. THE SUGAR CROP . . . . .	236
XXI. TOBACCO . . . . .	242
XXII. SILOS AND SILAGE . . . . .	248
XXIII. THE ORCHARD CROP . . . . .	262
XXIV. THE WOOD CROP . . . . .	279
XXV. PLANT DISEASES . . . . .	287
XXVI. INSECTS ON THE FARM . . . . .	300
XXVII. SPRAYING . . . . .	313
XXVIII. FEEDING ANIMALS . . . . .	320
XXIX. HORSES AND MULES . . . . .	330
XXX. DAIRY CATTLE . . . . .	353
XXXI. DAIRY PRODUCTS . . . . .	372
XXXII. BEEF CATTLE . . . . .	381
XXXIII. SWINE . . . . .	395
XXXIV. SHEEP . . . . .	409
XXXV. POULTRY . . . . .	418
XXXVI. BUSINESS ASPECTS OF FARMING . . . . .	436
XXXVII. MECHANICAL POWER FOR THE FARM . . . . .	449

## APPENDIXES

A. SINGLE-PLATE SCORE CARD — APPLES . . . . .	i
B. SCORE CARD FOR INDIVIDUAL EARS OF CORN . . . . .	ii
C. SCORE CARD — DRAFT HORSES . . . . .	iv
D. SCORE CARD — LIGHT HORSES . . . . .	vi
E. SCORE CARD — MULES . . . . .	viii
F. SCORE CARD — DAIRY CATTLE . . . . .	x
G. SCORE CARD — BEEF CATTLE . . . . .	xi
H. AGE OF DOMESTIC ANIMALS AS INDICATED BY THE TEETH . . . . .	xii
I. GENERAL SPRAY SCHEDULE FOR THE CONTROL OF THE IMPORTANT INSECTS AND DISEASES OF FRUITS AND VEGETABLES . . . . .	xiv
J. QUANTITY OF SEED TO SOW PER ACRE . . . . .	xvi
K. LEGAL WEIGHTS OF A BUSHEL . . . . .	xvii
L. A TABLE OF COMMON FARM WEEDS . . . . .	xviii
INDEX . . . . .	xxv

THE UNIVERSITY OF CHICAGO  
LIBRARY

THE BIBLE  
THE OLD TESTAMENT  
THE NEW TESTAMENT



SEEDTIME AND HARVEST

Whatsoever a man soweth, that shall he also reap. — THE BIBLE

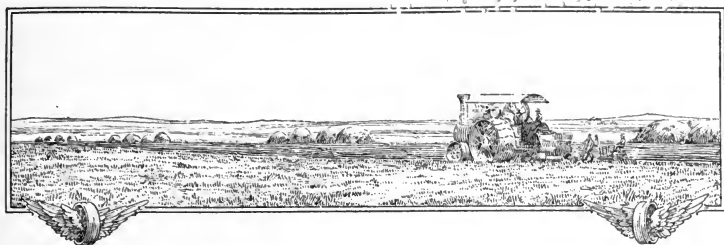

# THE ESSENTIALS OF AGRICULTURE

## CHAPTER I

### THE NEW AGRICULTURE

Here is a land where no bulls, breathing fire from their nostrils, have plowed the soil; where no enormous dragons' teeth were ever sown; where no human harvest started up, bristling with helmets and crowded lances; but teeming corn and the wine god's Massic juice have made it their own; its tenants are bursting crops and luxuriant herds of cattle. Hence comes the war horse that prances proudly into the battlefield. Hence the white flocks upon a thousand hills. Think, too, of stately cities and trophies of human toil and towns piled by man's hand with great rivers flowing beneath their honored walls. It is a land, too, which has disclosed streams of metal mantling in its veins, a land that has produced mortal tribes of heroic mold. Hail to thee, mighty mother of noble fruits and noble men! — VERGIL

**1. Modern agriculture.** Lord Bacon, a noted English philosopher, was at one time much interested in agriculture. He collected and read carefully many books on the subject. When he had finished reading the books, he ordered his servant to take them into the garden and burn them, because they dealt with the art or practices of agriculture and contained no principles.

In modern agriculture, art and science are combined. As an art, agriculture is complex and involves a study of the best practices connected with the field, the orchard, the garden, the barn, the feed-yard, and the dairy. But to understand the

principles underlying these practices, to know why one practice is better than another, or to develop practices which are better than those now in use, it is necessary to have some knowledge of almost every science now known to man.



FIG. 1 a. The reap hook

By means of this hook a few heads of grain were harvested at each stroke

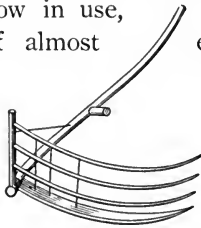

FIG. 1 b. The cradle

The cradle made it possible for an armful of grain to be cut at one stroke

**2. How science and invention have helped agriculture.** Although agriculture is the oldest and most important of our industries, it was among the last to receive attention from in-

ventors and scientists or to profit by their discoveries. The era of labor-saving machinery may be said to have had its beginning about a century ago with the invention of the iron plow.

As late as the middle years of the nineteenth century, farming was performed mostly by hand, and the world had made little progress in agriculture. The plow and the harrow were almost the only implements drawn by horses. Corn was dropped in furrows by hand, a practice which the early settlers had learned from the Indians. Wheat was

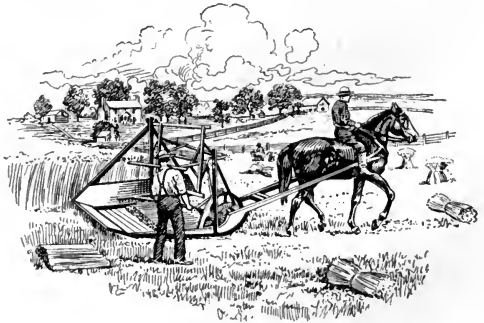

FIG. 2. The reaping machine

This is a model of the first successful reaper, which was invented by Cyrus H. McCormick in 1831. In its first trial the reaper was ordered out of the field because it "rattled the heads off the wheat." A friendly neighbor of the inventor offered his wheat field as a place in which "to give the machine a fair trial," and it cut grain successfully for five hours. For the first time "grain was cut with horses." But the machine and its inventor were discredited. The feeling of the neighborhood was well expressed by an old woman who said, "It is a smart curious sort of thing, but it won't ever come to much." It was ten years before the inventor found a buyer for one of his epoch-making machines

sown broadcast by hand, as in Bible days. Reaping was still done with the sickle and the cradle, with little improvement since early history (Figs. 1 *a*, 1 *b*, 2, and 3). Hay was mowed with a scythe and collected with a hand rake, and a wooden stick served as a fork for pitching it upon the stack.

The first epoch-making scientific discovery relating to agricultural practice was made by the German chemist Liebig (Fig. 4) and was first announced in 1840. Liebig showed where



FIG. 3. A modern wheat-heading-and-threshing machine

The power is furnished in this case by thirty-three mules. The threshed wheat is left in bags ready for market

and how plants obtain their food and how wornout soil can be restored to productiveness by the use of artificial fertilizers.

In 1845 the people of the United States did not raise enough wheat for their bread. At that time the production was only 4.33 bushels for each person. In 1859 the production had been increased to 5.6 bushels for each person ; in 1869, to 7.5 bushels ; and in 1879, to 9.2 bushels. In 1830 it required three hours of man's labor to produce a bushel of wheat ; in 1896 it required only ten minutes. In 1850 the labor represented in a bushel of corn was four and a half hours ; by 1894 this had been

reduced to forty-one minutes. In 1860 the labor invested in a ton of hay was thirty-five and a half hours; in 1894 the labor cost of a ton of hay had been reduced to eleven and a half hours.

Within the last twenty years the production of wheat in the world has increased almost one half, while the area sown has increased only one fourth. Since 1880 wheat production

has increased about 66 per cent, while the population has not increased as much as 30 per cent.

### 3. Increased production followed by better living.

If the people of the world had subsisted for four thousand years under the ancient system of agriculture, and if more improvements in methods were made in the last fifty years than in the thousands of years before, the student may wonder what became of the increased production and why there was not a serious over-production of food. The truth is that up to the time of the birth of the new agriculture the world had not

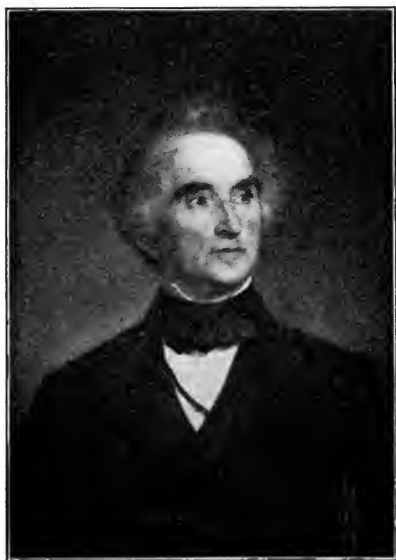

FIG. 4. Baron Justus von Liebig

A German scientist who first applied the principles of chemistry to agriculture, and discovered a scientific method of feeding plants

had enough to eat. Much of the increased output due to better machinery and better methods was absorbed in higher standards of living. When our forefathers were fighting forests, Indians, and poverty, a peck of wheat was a fair yearly allowance of that article of food for a whole family. To-day each person in the United States consumes, on an average, between five and six bushels of wheat each year. Meat at that time was scarce and difficult to procure. To-day each family consumes an average of



a half ton of meat each year. Under the new systems of farming fewer people are needed on the farm to produce a living for the world than formerly and more people are engaged in nonproductive occupations and live in town. For example, a century ago more than nine tenths of the people of the United States lived on farms and were directly dependent upon agriculture for a living. In 1910 about one third of the people were engaged in agricultural occupations. Formerly a farm supported a family and produced a small surplus to supply the needs of the few people who lived in town. To-day each farm is required to support three families—the one that lives on the farm and tills its fields, and two that live in town.

**4. Overproduction and high cost of living.** Nevertheless, there was an actual overproduction of food closely following the bringing of the prairies of the Middle West, Northwest, and Pacific West under the plow, when the ox team was supplanted by the locomotive and the grain cradle was displaced by the reaper. Then for the first time the world had bread enough and to spare. An era of low cost of living was ushered in, and we foolishly believed it was permanent. Consumption has again caught up with production, however, and in two decades food prices have risen from the lowest to the highest point in history. In all probability the present high cost of living is permanent. There is no longer an unoccupied "out West" with its favorable climate and fertile soil. Increase in population and higher standards of living will easily absorb all the increase in production that we shall be likely to make by the adoption of better methods of tillage and by the use of better plants and animals.

**5. High man-yields should go with high acre-yields.** The acre-yield in America under extensive systems of agriculture is low, but the man-yield is high. In European and Asiatic countries under systems of intensive farming, the acre-yield is high and the man-yield is low. For example, the acre-yield of wheat in America is little more than 14 bushels, while in Germany it is 31 bushels, in France almost 30 bushels, and in Japan 24 bushels. But the yearly income for each farm family in America

is approximately \$1000 as compared with \$580 in Germany, \$570 in France, and \$235 in Japan.

The standard of intelligence of the people on the farm in any country is directly related to the income derived from farming as compared with that derived from other occupations. If

farming is allowed to become unprofitable in comparison with other occupations, the business will be given over to less efficient persons than are now on the farm. Everyone, whether in the country or in the city, is interested in having the American farm yield an income large enough to keep on the farm a fair share of the best people born there.

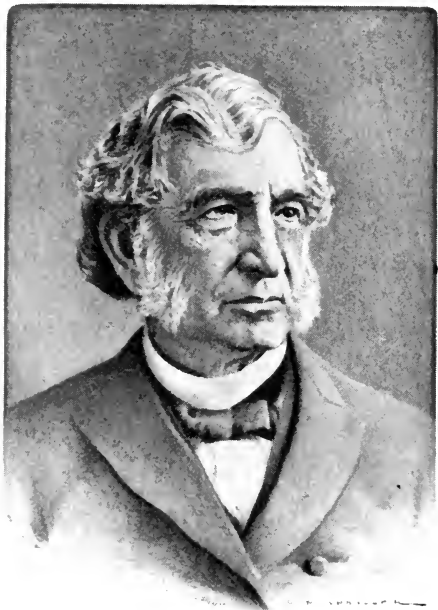

FIG. 5. Justin Smith Morrill (1810-1898)

Author of the Morrill Act, passed by Congress in 1862, appropriating land to promote education in agriculture, mechanic arts, and the natural sciences in every state in the Union. This is the most influential single piece of legislation upon agricultural education

**6. Intensive agriculture helps society but hurts the farmer.** Intensive agriculture is favorable to society at large, but it is unfavorable to the people on the farm. It is essentially hand farming and is adapted only to con-

ditions where land is dear and labor is cheap.

Extensive agriculture develops the highest form of rural civilization, because it gives an income above the physical needs of the family. It is the kind of agriculture that uses much machinery and raises much live stock, and these two conditions

in themselves develop a high type of husbandman. As a business extensive agriculture is on a level with merchandizing, publishing, and the learned professions with respect to the income it yields and the intelligence and experience required successfully to conduct it; and this serves greatly to increase the respect which the farmer has for himself and for his business.

As long as a country can get along with farms of a reasonable size it is not advisable to try to force upon it an intensive type of farming. No country has ever adopted intensive farming until forced to do so to give people a chance to work, or by the demand of society for cheaper food. Therefore, until society is made to suffer undue hardships on account of the high cost of living, a reasonably extensive system of agriculture is the best for everybody.

#### QUESTIONS AND PROBLEMS

1. Why should Lord Bacon have ordered his servant to burn the books on agriculture?
2. Why is a knowledge of both the art and the science of agriculture necessary?
3. What marks the beginning of the era of labor-saving machinery?
4. What was the first epoch-making scientific discovery relating to agricultural practice?
5. Give illustrations showing when real agricultural development began.
6. Sketch briefly the development in wheat production since 1845.
7. Explain what became of the increase in the production of wheat.
8. What is the relation between man-yields and acre-yields?
9. Compare extensive and intensive farming as to their respective effects on society and on the farmer.

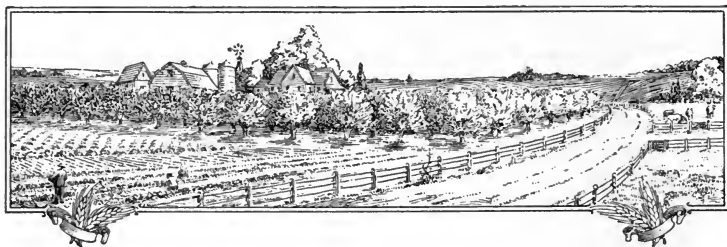

## CHAPTER II

### BETTER PLANTS AND ANIMALS

Still will the seeds, though chosen with toilsome pains  
Degenerate, if man's industrious hand  
Cull not each year the largest and the best. — VERGIL

**7. Plants and animals improved by man.** All of our cultivated plants and domestic animals have been so improved that they serve man's purposes better than the wild parents from which they came. We can still gather pecans, strawberries, plums, and persimmons in the wild state, but the selected, cultivated sorts are of greater size and better flavor and are very much more productive than those which wild nature offers us.

Beef and dairy breeds of cattle have been developed, each distinct from the other, and even among the dairy breeds themselves we have great diversity. Five races of corn had already come into existence before the discovery of America (Fig. 6). Recently, special strains of alfalfa resistant to cold and others resistant to drought have been developed. Wheats have been produced that are resistant to drought, and others that are resistant to rust. Indeed, the possibility of improving plants and animals so that they will be resistant to diseases has great promise in modern agriculture.

**8. When plant improvement began.** In case of most of our cultivated plants the exact period in which their cultivation began is unknown. A Swiss botanist<sup>1</sup> enumerates two hundred

<sup>1</sup> Alphonse de Candolle, *Origin of Cultivated Plants*. 1882.

and forty-seven species of cultivated plants known to civilized man, of which forty-four species have been cultivated for more than four thousand years. Among these ancient plants are wheat, barley, millet, sorghum, rice, flax, hemp, cabbage, onions, turnips, grapes, apricots, peaches, pears, quinces, apples, olives, figs, dates, and bananas.

**9. How new varieties are produced.** Nearly every plant which has been long in cultivation is represented by many distinct varieties. Indeed, the number of existing varieties of a cultivated plant is likely to be closely related to the length of

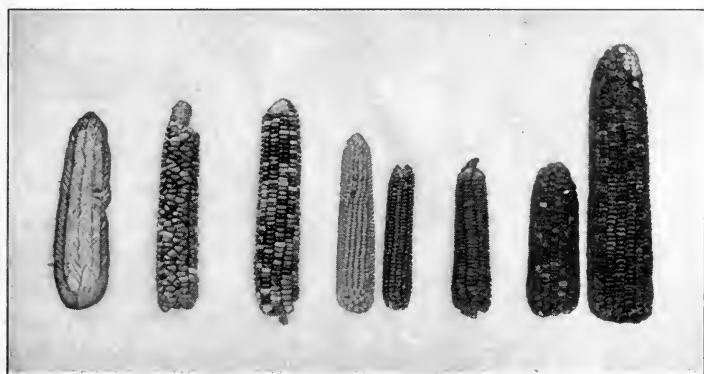

FIG. 6. Kinds of corn

From left to right the kinds of corn are pod, flint, pop, sweet, and dent

time it has been in cultivation. In most cases the varieties are especially developed with respect to some one or more of their parts; for example, we have the great roots of the sugar beet, the large leaf heads of cabbage and lettuce, the flower heads of cauliflower, and the flowers of the cultivated strains of pansies. The way in which new varieties are produced may be best learned by studying the history of a few cases.

**10. The Concord grape a chance seedling.** In the year 1840 some boys of the village of Concord, Massachusetts, who had been gathering wild grapes in the woods, on returning to their homes, strewed the seeds of their spoil upon the land of

Mr. Ephraim Bull. A chance seedling from this vagabond sowing was preserved by him, and when it fruited, three years later, Mr. Bull sowed the seeds of its only cluster of fruit. Nine years after the accidental sowing, one of the second generation of seedlings proved to be so far superior to all of the others (Fig. 7) that the rest were destroyed, and the

survivor became the Concord grape. This example illustrates how a cultivated plant may originate from a wild one.

**11. The Burbank potato.** One day in the decade beginning in 1870 Luther Burbank, who was then a young man in Lancaster, Massachusetts, working in his market garden, found a single seed ball on a plant in a field of Early Rose potatoes. He saved the seeds, and planted them, and there grew a seedling which yielded tubers of unusual size

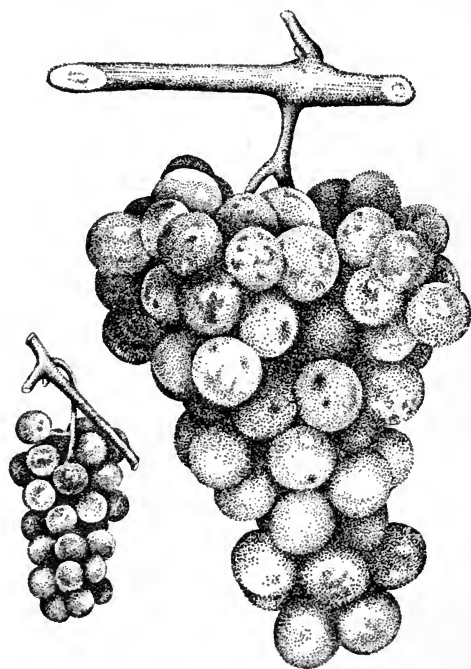

FIG. 7. The Concord grape (at right), and its parent (at left)

and quality. Thus he found the potato which bears his name, and which has added millions of dollars to the products of agriculture.

**12. Improvement by systematic selection.** In walking through the fields of grain near his native village in Scotland, Patrick Shirreff in the year 1819 happened upon what seemed to be an exceptional wheat plant, bearing on sixty-three heads some twenty-five hundred kernels. The seeds from the plant were

saved and sown in a special plot, and in two years sufficient seed had been obtained to warrant his putting it upon the market as a new variety. This wheat, by virtue of its superiority, soon came into general cultivation in Scotland, and spread into England and France. Mr. Shirreff continued to select heads from the better-appearing wheat plants in the fields of his neighborhood and soon had as many as seventy different heads. He planted the grains of each head separately, by what we now call the ear-row method. He was thus able to compare the yields and the characteristics of the plants of the different rows with one another. Out of the seventy ear-rows, only three were saved. These three strains, or, as we might say, varieties, became quite generally distributed in Scotland and England, and even spread to the Continent.

These examples illustrate ways in which new varieties may come into existence. We have obtained most of our improved forms of plants through selection, which merely discovers and preserves to our uses that which nature has in some unknown way produced already.

**13. Variation in plants and animals.** Everywhere in nature there is variation, and variations give us the material from which to make selection. No two plants or animals are ever exactly alike. Sometimes, as in the case of the amount of sugar contained in the sugar beet, it seems impossible to fix these variations by selection. In such a case we call them fluctuating variations, without in any way understanding why they fluctuate. In other instances, as in the case of corn with different numbers of kernel rows on the ear, or of corn that bears its ears at different heights on the stalk, it is possible to separate different breeds which will come approximately true. An interesting experiment<sup>1</sup> with corn was made which resulted in fixing the ears high or low on the stalk by continued selection (Fig. 8). After six years of continued selection there had been developed two kinds of corn—one bearing its ears at an average of four feet nine inches above the ground, and another bearing its ears at an average of only two

<sup>1</sup> *Bulletin 128*, Illinois Experiment Station.

feet above the ground. This had been accomplished by selection alone, the ears high on the stalk being selected each year as seed for producing the "high-ear" corn, and ears low on the stalk being selected as seed for the "low-ear" corn plots.



FIG. 8. Fixing the height of the corn ear by selection

Will the improved races persist without continuance of the selection? In most cases the methods by which the improvement was brought about must be kept up to prevent the race from going back to its original type. Where continued selection has permanently improved the race of plants or animals, it is probable that the desired characters had previously been



concealed among many others. The continued selection simply amounted to a weeding-out process, whereby the better race was gradually made more nearly pure and freed from its poorer associates.

**14. The ear-row method better than mass selection.** By the method formerly general in both Europe and America, and still practiced to some extent, a considerable number of heads from an ordinary field are selected and weighed, and the heaviest saved for planting. The next year selection from the field is made in the same way, and so on indefinitely. There is no question but that a continuous advance is made by this method, but progress is slow because it is not possible to weed out all the poorer individuals and save only the best for seed. A field of wheat, for example, consists of millions of individuals, each with its own characteristics, powers, and capabilities.

A field of wheat may be compared to a great city. Some of the inhabitants come from sound families, others from those which are unsound. If men were to be selected from New York City for an Arctic expedition to last three years, in addition to requiring of applicants conformity to certain physical standards, the family histories of the applicants would be examined for probable latent defects. Selection would be rigid. Or suppose one man were desired out of that great city's population to act as a secret-service bodyguard to the president of the United States. It is likely that the family histories of the applicants would be even more rigidly and thoroughly examined, since selection is limited to choosing one individual.

A field of wheat may be thought of as a city of wheat plants, all slightly different from one another. It is plain that if we select one hundred of the best-appearing, or heaviest, or largest heads, we shall probably get as offspring from them many wheat plants that average better than the general population. If we go a step farther, we may find a way of selecting the best wheat plant in the field. In the case of the supposed bodyguard selected from several millions of a large city population, we should both test the man and study his family. In the case of wheat we test

the family first. We grow a great many separate families and test their progeny. We compare these families for several years in nursery rows, in small plots, and finally in the field, in order to determine such matters as yield, earliness, winter-hardiness, rust resistance, the hardness and milling quality of the grain, and the baking quality of the flour.

The above method, commonly known as the ear-row method, was originated nearly a hundred years ago, but was forgotten. In the meantime nearly all the plant breeders in Europe and the United States sought to gain all their results by selecting plants by regiments, until the method of taking them separately as individuals was rediscovered. This is the process by which the best families, or strains, are most quickly sorted out, and is the method now followed in this country and in Europe by nearly everyone who is trying to improve the standard of agricultural plants.

**15. Making new varieties by crossing.** The most important method of plant improvement is the breeding, or actual creation, of new kinds of plants. Selection creates nothing new. It simply finds and uses the best of what already exists. Breeding goes further and, through the crossing of favorable parent plants and animals, produces new types of offspring. In 1865 a highly important law of crossing, or hybridization, was discovered. This law is of such importance that all of our modern scientific knowledge of plant and animal breeding dates from the work of the Austrian monk, Gregor Mendel, which was first published in the reports of a scientific society of Brünn in Austria, but which, strange to say, remained unknown to science until, in 1900, it was rediscovered almost simultaneously by three noted European botanists.<sup>1</sup>

**16. Mendel's Law.** Mendel experimented with garden peas and found that different kinds of peas differed in certain respects when the plants were crossed. He found, among other things, that peas differed in the color of the ripe seeds (whether

<sup>1</sup> Professor Hugo de Vries of Holland, Professor Erich Tschermak of Austria, Professor Carl Correns of Germany.

yellow or green) and in the shape of the ripe seeds (whether smooth or wrinkled). Mendel then discovered that if he crossed, for example, a plant bearing smooth peas with a plant bearing wrinkled peas, the *hybrid* plant coming from such a cross would bear all smooth seeds. He also found that other pairs of characters with which he experimented behaved in a manner similar to the behavior of the smoothness or wrinkledness of the seeds of peas. In the first generation one character dominated and appeared alone, apparently to the total exclusion of the other. In this first generation, however, it was supposed that in reality the character not appearing was actually present but was hidden by the so-called *dominant* character. The character thus hidden is called the *recessive* character.

It was found by further experiment with plants and animals that certain characters are always dominant in the first generation, while others are always recessive. For example, when tall-stemmed and short-stemmed



FIG. 9. Smooth and bearded wheats

When smooth and bearded wheats are crossed, all the heads in the first generation are smooth

pea plants are crossed, the tall-stemmed character is dominant in the offspring of the first generation. When pea plants bearing their flowers along the stem are crossed with those which bear their flowers bunched at the end of the stem, the offspring all bear their flowers along the stem, the character of bearing the flowers at the end of the stem being recessive. When bearded and beardless wheats (Fig. 9) are crossed, the first generation is beardless. Long-staple cotton crossed with short-staple

cotton (Fig. 10) produces hybrids bearing only long-staple cotton. Polled cattle when crossed with horned cattle (Fig. 11) produce offspring none of which have horns in the first generation. When trotting and pacing horses are crossed, all the offspring in the first generation trot.

**17. The appearance of succeeding generations.** It was also found by Mendel that in the generations following the first hybrids the dominant and recessive characters would appear in definite proportions. For example, if the smooth-seeded peas which were produced as hybrids in the cross between smooth and wrinkled peas were sown, one fourth of the seeds they



FIG. 10. Long-staple and short-staple cotton

When long-staple and short-staple cotton are crossed, all the fibers in the first generation are long staple

produced would be wrinkled, while three fourths would be smooth. If the wrinkled seeds were then sown, they would produce plants bearing only wrinkled seeds. But if all the smooth seeds were again sown, one third of them would produce plants bearing smooth seeds, while the other two thirds would bear both smooth and wrinkled seeds in the ratio of 3 : 1, as at first.

In every generation after the first there thus *appear* to be two kinds of seeds, of which one fourth are wrinkled and three fourths are smooth. After the first generation, however, *there are really three kinds of seeds*, although this fact is not evident.

1. One fourth are *smooth seeds* and grow into plants that produce smooth seeds that come true.

2. One fourth are *wrinkled seeds* and grow into plants that produce wrinkled seeds that come true.

3. One half are *smooth seeds* and grow into plants that produce seeds of which *one fourth* are *wrinkled* and *three fourths* are *smooth*.

**18. Producing new characters by crossing.** Two white-flowered sweet peas of the same variety were crossed. These resembled each other in all respects, except that one plant bore flowers with long pollen grains, and the other bore flowers with



FIG. 11. Polled and horned cattle

When polled and horned cattle are crossed, the first generation is polled

round pollen grains. The hybrid bore purple flowers, a totally new character. One of these hybrid plants bearing purple flowers was crossed with another like itself. Of the offspring of this cross twenty-seven plants bore purple flowers, nine bore red flowers, and twenty-eight bore white flowers. Not only did the purple character persist but the new character, red, appeared. The limits of production of new characters by crossing are not known, and a great deal of experimentation is being done on this phase of the question.

**19. Character present or absent.** It has recently been discovered that there are not two opposing characters, as was at

first supposed, but that a given character is present in the one case and absent in the other case. When the cross is made, the character present in one parent goes into the hybrid, while the other parent does not contribute anything to that character. Consequently the one character is dominant in the sense that it is present. For example, in the case of smooth and wrinkled seeds the smoothness is due to the presence of a ferment, or enzyme, in the seeds, which changes the sugar in the growing seed into starch, whereby the seed is more perfectly filled out and is consequently smooth. In the case of the wrinkled seeds



FIG. 12 a. Razorback, or unimproved hog  
Matures slowly, and is less valuable when mature

this ferment is absent, the sugar remains unchanged, and since the cells are not filled with solid starch grains but with a watery sugar solution, the seeds, on drying, shrivel and hence become wrinkled. In the case of green seeds in peas an enzyme destroys the green

material known as chlorophyll and leaves only the yellow color; therefore the seeds are yellow. In the case of green peas the enzyme is absent; hence the yellow color is obscured by the green color and the peas appear green.

In a word, Mendel found that a plant (and the same has since been found true of animals) in respect to its characters is, as it were, like a child's playhouse, constructed of many different shapes, kinds, and colors of building blocks, which can be taken to pieces and put together again in a new way, so as to make a structure entirely different in appearance, although built from the same materials. The house is the plant or animal, and the

characters, such as the color of the flowers or hair, the markings on the seeds, the shape and size of the leaves and the height of the stems, the horned or polled character in cattle, the gait of the horse (whether the trot or the pace), are the blocks. The blocks that represent single characters are called units, and the characters that behave like units, that is, that cannot be broken up, are called unit characters, or unit factors. Sometimes we find that it takes more than one unit to make a character.

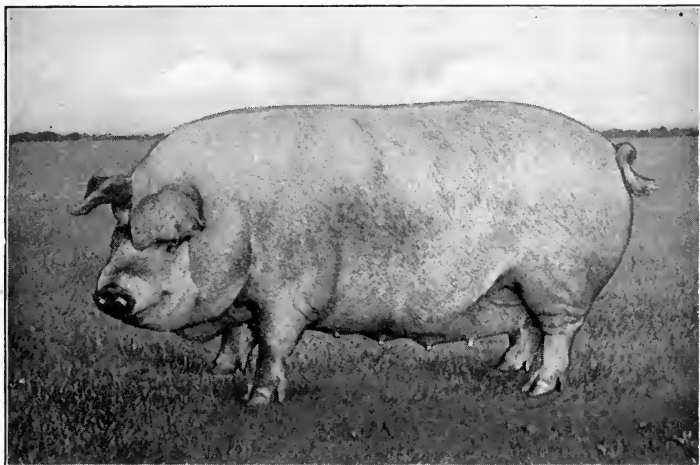

FIG. 12 *b*. The modern, improved type of hog  
Matures rapidly, and is more valuable when mature

**20. Mendel's Law and the breeder.** Without a knowledge of Mendel's Law, man has developed a great many pure breeds of animals and plants, all within comparatively recent times. An understanding of this law, however, will prove of great value by showing how to produce many more breeds and, especially, how to produce them more quickly. It will help to show the necessity of using pure strains when experimenting not to produce new types but to grow a particular kind or quality of plant or animal. It helps to show that what appears to be the character of a hybrid may or may not appear in the next generation. And

it furnishes the man who wishes to experiment, with a scientific basis upon which his experiments may be conducted.

**21. Improved plants and animals require constant care.** Plant and animal improvement cannot be made by selection and breeding alone. Feeding and care are equally important (Figs. 12 *a* and 12 *b*). The more highly developed plants and animals become, the more dependent are they upon man. When our agricultural plants grew wild, they were planted by natural means, required no cultivation, and fought their own battles with other wild plants. If they were now left to their own resources, many of them would

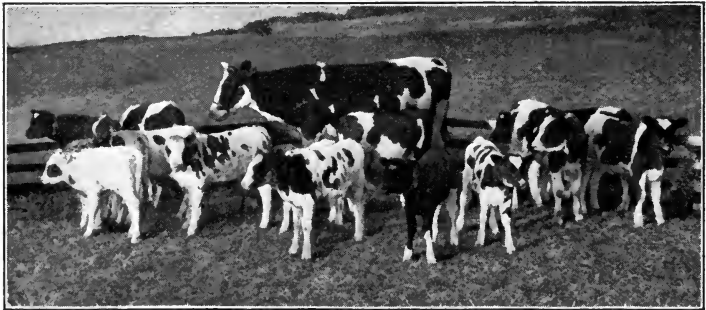

FIG. 13. An improved cow and the calves which her milk might have nourished

A modern, high-grade cow may give enough milk to nourish fifteen calves. The unimproved cow gave scarcely enough milk to sustain one calf

not survive. It is doubtful if our highly developed beef and dairy cattle would survive if left to subsist, unaided by man, on the wild steppes of Russia or in the dense jungles of the tropics. Certainly if they did survive, it would be because they had the power quickly to revert to the unimproved type. They would live because of their power to throw off what man has been centuries in developing.

This does not mean that improved animals and plants are weaker than their wild ancestors. It means merely that the conditions under which wild plants and wild animals live are very different from those under which domesticated forms live, and



that a successful type under one set of conditions is not likely to succeed under the other set of conditions.

In other respects than the mere power to get along under difficulties, the domesticated and improved species are much more powerful than wild species. For example, the specialized beef animal is capable of attaining a greater weight at twelve months of age than that which the unimproved type attains when fully grown. The wild cow produced only enough milk to nourish one calf for a few months. Some of the best of the modern cows have produced an amount of milk which might have nourished fifteen calves (Fig. 13). There is no plant in wild nature that compares with corn in its power to produce grain and forage or that will compare with wheat, oats, or rice in grain production.

The more we improve and specialize our plants and animals, the farther we remove them from wild nature; and the more we increase their power to produce under favorable conditions, the more we diminish their power to get along under adverse conditions. The farmer of the future will not be concerned as to how much hardship his plants and animals, if left uncared for, will endure and survive, but rather as to the largest quantity of highly specialized products that they can produce under the best conditions. Therefore, in scientific agriculture — the agriculture of the future — the highest esteem will not be bestowed, as it is in wild nature, upon those plants and animals which can survive under the most adverse conditions, but upon those which respond most generously to good treatment.

When we consider the plant population of the world's cultivated fields to-day and realize how new varieties have sprung up, how new forms have multiplied, as our uses and tastes and needs have grown; when we realize how much of this production of new breeds of plants is the result of the work of little more than two centuries; and when we realize how great are the opportunities for further improving even the oldest and best known of our agricultural plants and animals — then we may begin to understand the greatness of the new agriculture.

### QUESTIONS AND PROBLEMS

1. Prepare a list of your best local examples of plants and animals which are the results of improvement over less desirable ancestors.
2. What are the local cultivated plants which have been longest cultivated by man?
3. How was the Concord grape developed? the Burbank potato?
4. What were the methods by which Patrick Shirreff developed new strains of wheat?
5. What is meant by variation among plants and animals? In man's problems of improvement of plants and animals, what use does he make of variations?
6. In what respects is the "ear-row" method of selecting plants better than "mass" selection?
7. Explain what is meant by crossing plants or animals. In what ways may crossing contribute to the making of new varieties?
8. Explain briefly how Mendel discovered the law known as Mendel's Law.
9. How does a knowledge of Mendel's Law help the breeder?
10. Explain and illustrate the meaning of "The more highly developed plants and animals become, the more dependent are they upon man."
11. What plants and animals are most likely to be chosen as subjects for development?

### REFERENCES

- BAILEY, L. H. *The Evolution of our Native Fruits*. The Macmillan Company.
- BAILEY and GILBERT. *Plant Breeding*. The Macmillan Company.
- COULTER, J. M. *Fundamentals of Plant Breeding*. D. Appleton and Company.
- DARBISHIRE, A. D. *Breeding and the Mendelian Discovery*. Cassell and Company.
- DARWIN, CHARLES. *Variation of Animals and Plants under Domestication*. 2 vols. D. Appleton and Company.
- DE CANDOLLE, A. *Origin of Cultivated Plants*. D. Appleton and Company.
- SHALER, NATHANIEL. *Domesticated Animals. Their relation to man and to his advancement in civilization*. Charles Scribner's Sons.



## CHAPTER III

### HOW PLANTS FEED AND GROW

Whoever will be perfect in the science of agriculture must be well acquainted with the qualities of soils and plants and must not be ignorant of the various climates, so that he may know what is agreeable and what is repugnant to each. — COLUMELLA

**22. Factors that determine the harvest.** In the spring a farmer carries to the field a dozen ears of seed corn and in the fall brings back a harvest of perhaps thirty thousand pounds of green forage, or ten thousand ripened ears. Some very important things have happened between the time when the farmer dropped the seed into the warm earth and the time when he brought home the harvest. Where did the increase come from? Will the increase always be the same?

The four factors which, combined, determine the abundance of the harvest are the seed, the soil, the culture, and the climate. Man determines the kind of seeds he will sow, and whether or not they shall inherit high producing powers. He determines to a considerable extent the productiveness of the soil, and with judgment and skill he regulates the processes of cultivating, harvesting, and housing the crop. It is only the climate which he cannot modify, but to it he may adapt his practices and his plants.

**23. Old crops in new climates.** It is of prime importance for the farmer to know how to adapt his practices to the general climate of the region and to the wide range of seasons it affords.

For example, when the farmers of humid regions have moved into regions of limited rainfall, their difficulties have been greatly increased because they have taken with them the crops and methods used in humid climates. On the other hand, when some Russian immigrants brought wheat which had been grown for centuries in a comparatively dry climate to a region in the United States where the rainfall was limited, the result was that wheat farming prospered beyond the hopes even of the first settlers. The development of a corn suited to the climate of the North changed corn-growing from uncertainty to certainty. In China and Africa the sorghums are plants which are capable of withstanding long droughts. These have been introduced into regions of limited rainfall in the United States, with the result that large stretches of fertile soil which otherwise would have been suitable only for grazing have been made into successful farms.

**24. Where plants get their food.** The young plant lives on the food already stored in the seed, tuber, or other part planted, until it has developed a system of feeding roots, and until its leaves have been unfolded in the air and light. The plant is then usually able to live on the soil and air entirely, but it stands a much better chance of making a satisfactory development if the part planted contains a sufficient reserve of food to help sustain the plant while it is young. This is especially important when the weather or soil conditions are not ideal for the nourishment of the tender plant. It is interesting to know that beans, for example, may be grown to the flowering stage without nutritive salts from the ground, the plant depending entirely on the stored-up food in the thick, fleshy seed leaves. This is one reason why corn, which contains an abundance of food and which germinates vigorously, is chosen for seed, and why the piece of potato which is planted is of larger size than is required to support the plant until its leaves reach the surface. Besides the food which is obtained from the parent, the growing plant makes food from materials which it secures from the soil through its roots and from the air through its leaves.

**25. Taking the plant apart.** When a plant is analyzed chemically it is found to consist of water, organic matter, and ash. About 75 per cent of the average growing green plant is water. A field of growing corn has been found to contain as much as 80 per cent of water; a potato crop, 79 per cent; and a cabbage patch, 91 per cent. Cured hay contains from 8 to 12 per cent of water, and corn in the crib, from 8 to 14 per cent. Therefore, if a green corn plant is dried and weighed, there may be left only 20 per cent of the original weight. The water has been driven off by heat. When this dry material is burned and weighed, only about 1 per cent of the original weight is left as ash. The organic matter has been burned and has passed off into the air in the form of gases, as in the case of the organic matter of wood or coal burned in the stove or furnace. Thus, the green corn plant is about 80 per cent water, 19 per cent organic matter, and 1 per cent ash.

Most of the organic matter of plants is carbon, which is obtained from the air through the leaves. Nitrogen is a part of the organic matter and came originally from the air. Only a few plants are able to feed upon nitrogen in the free state in which it exists in the air, and all of the agricultural plants except the legumes, such as beans, peas, and clovers which are discussed later, take all their nitrogen from the soil, in which it is combined with other elements. The water, the ash, and the nitrogen, except the nitrogen which the legumes take from the air, are obtained from the soil through the roots.

**26. Elements of plant food.** Water is composed of hydrogen and oxygen. Organic matter is composed of carbon, nitrogen, and the same elements as water. The ash, or the mineral part of plants, consists of phosphorus, potassium, calcium, iron, sulphur, and magnesium, all of which are absolutely essential to the life and growth of plants. To these must be added the equally indispensable four elements coming from the air—carbon, hydrogen, oxygen, and nitrogen. Thus, there are at least ten elements absolutely necessary for all plants. In the ash of nearly all plants sodium, silicon, and chlorine are also found, and in many plants

manganese occurs, but these elements are not considered essential to the life of plants. While only very small quantities of some of these elements, such as iron and sulphur, are required, any attempt to grow crops without them results in failure. All of the elements, except carbon and a part of the oxygen, are obtained by most plants from the soil alone, though some of the

elements have come to the soil from the air. A soil, therefore, from which plants fail to secure one or more of these elements makes a poor farm.

**27. How plants get their food.** The raw food materials in the soil must be dissolved in water before the plants can take them up through their roots. Therefore the soil water serves a double purpose — as food for the crop, and as a carrier of other food elements. The roots penetrate the soil in all directions, wherever there is air and moisture (Fig. 14). The roots of a corn or sunflower plant fill a cubic yard of soil with tiny rootlets. The roots produced in a season by a wheat plant, if placed end to end, would extend

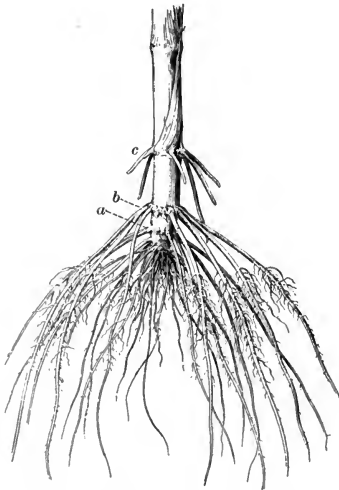

FIG. 14. Root system of a corn plant

The roots spread and form an extensive mat within the soil. The root hairs are not shown in this picture. Note the series of brace roots at *a*, *b*, and *c*, those at *c* not having reached to the soil

a third of a mile. A pumpkin vine may produce fifteen miles of roots in a season.

**28. The nature and extent of root hairs.** The tiny rootlets do not themselves absorb much water. This is done by minute root hairs sometimes numbering 25,000 to the square inch of root surface. These grow in feathery tufts near the tips of the smallest rootlets. The root hairs begin as projections on the outside cells of the rootlets (Fig. 15), at a point about a third of an inch

back from their tips. These projections wind about in every direction among the soil particles, to which they closely adhere. The root hairs may increase the absorbing surface of corn roots five and one-half times, and of barley roots twelve times.

**29. How root hairs secure water from the soil.** The soil is made up of a multitude of fine particles. Each particle is surrounded by a thin film of water held there by the force of gravity. The water nearest the soil par-

icle is held more firmly than that farther away. The way in which the root hairs are able to pull the water from the soil particles may be shown by a simple experiment. If a bladder or a bag made from parchment paper is filled with water containing 10 per cent of sugar, and if one end of a glass tube is fastened in the bladder and the bladder placed in a pan of pure water, interesting results follow. The sugar solution will rise in the tube, and the distance to which it rises, hour by hour, can be watched. Imagine the thin wall of the root hair to correspond to the bladder, and the sap inside the root-hair cell to correspond to the sugar solution. The sap is a denser or more concentrated solution than the water in the soil outside of the root hair. The water in the

soil moves through the wall of the root hair, just as the water in the basin moves through the bladder toward the inside, so that the quantity of water on the inside increases; that is, the less dense solution always moves toward the more dense solution. This gives rise to a pressure (osmotic pressure) which is sometimes considerable, and is called root pressure. It is one of the factors which cause the sap to rise in plants. It is one of the causes, perhaps the chief cause, of the bleeding of injured

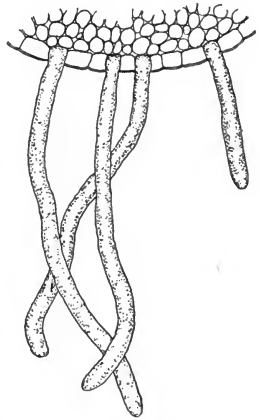

FIG. 15. Root hairs grow from the surface of the smallest rootlets

Root hairs are produced in very great numbers and extend into the soil, where they take up water and substances in solution in water

trees and grapevines in the early spring. The sugar-maple tree is bled by tapping, and its sap is collected and boiled down to sirup or sugar.

When the ground is warm and moist the root hairs absorb water most readily. Furthermore, the roots will not grow and produce the many rootlets which bear the root hairs unless the soil is well supplied with air, since the roots grow only when they can secure the oxygen of the air that circulates through the soil.

**30. Only part of the soil water used by plants.** Not all the water in the soil can be absorbed by the root hairs. Some water is left in the soil during the severest droughts, after all the plants have withered. This amount may be as much as 5 or 10 per cent in ordinary agricultural soils. The amount of this unavailable water varies in different soils, being greater in a fine fertile loam than in a sandy soil, because the greater the number of the soil particles, the greater the number of films of water that will be held. Different kinds of plants, moreover, vary with respect to the degree to which they can exhaust the water of the soil. Lettuce and cucumbers leave in the soil from 8 to 10 per cent of water which they are unable to withdraw, while corn and cabbage in the same soil leave only 6 per cent.

**31. The amount of water required by plants.** In more than half the area of the United States, and indeed of the world, there is not enough water available in the average season for a maximum yield of crops. In the central part of the United States agricultural plants, on the average, take about four hundred and fifty pounds of water from the soil for every pound of dry matter produced. It is of the greatest importance, therefore, to find out what plants will produce a pound of dry matter on the least water drawn from the soil. By careful experiments<sup>1</sup> the pounds of water which under ordinary conditions are drawn from the soil for every pound of dry matter manufactured by certain plants has been ascertained to be as follows :

<sup>1</sup> *Bulletin 284* and *Bulletin 285*, United States Department of Agriculture.



	POUNDS		POUNDS
Millet . . . . .	275	Wheat . . . . .	507
Pigweeds and Russian thistles	322	Oats . . . . .	614
Sorghums . . . . .	306	Sweet clover . . . . .	709
Corn . . . . .	369	Rye . . . . .	724
Sugar beets . . . . .	377	Canada field peas . . . . .	800
Potatoes . . . . .	488	Alfalfa . . . . .	1068

From this table it is easy to understand why oats require a moist climate, as compared with millet. Taking wheat as a standard, the table shows that the sorghums require little more than half as much water as wheat; corn, three-quarters as much; oats and sweet clover, about one and one-half times as much; alfalfa, more than twice as much. Different varieties of the same plant require different amounts of water. For example, a drought-resistant corn from Mexico requires only three hundred and nineteen pounds of water for a pound of dry matter, while Iowa Silver Mine corn uses four hundred and twenty pounds. Of all agricultural plants tested, alfalfa requires the most water. Alfalfa, by reason of its deep-rooting habit, feeds through a greater area than other plants, and is therefore among the last to suffer. The large amount of water used by alfalfa explains why crops that follow alfalfa, such as corn, often suffer for lack of sufficient moisture.

**32. Plants on fertile soil use water economically.** Plants which grow in well-manured soils produce crops on less water than plants growing on poor soil. This is because plants on fertile soil grow rapidly, and manufacture a given amount of plant material in less time than when growing in poor soil. In poor soil plants manufacture little or nothing for long periods, although the water passes through their bodies all of the time. High fertility, therefore, means more rapid production and consequently cheaper farming. Plants must be rushed at their work.

**33. How the plant gets rid of surplus water.** To maintain rapid, economical growth, a constant stream of water, carrying the nutrients from the soil, must pass into the plant. Most of the water passes through the plant and into the air as a vapor.

A small part of the water, the nitrogen and the mineral elements, are left in the plant and later made into new plant tissues. In the surface layer, or epidermis, of the leaves of plants there are many small pores through which the water passes to the outside air. These pores are known as *stomata* (*stoma*, singular, meaning "mouth"). The stomatal opening is surrounded by a pair of surface cells, known as guard cells. In dry weather the guard cells are usually affected so as to close the opening, and in damp weather, so as to leave it open.

The number of stomata on the leaves varies on an average from about 24,000 to 180,000 a square inch, although there are plants, such as the olive tree, in which the number runs as high as 375,000 a square inch, and in rape the enormous number of 429,600 a square inch is reached. It is said that an average leaf of rape contains as many as 11,000,000 stomata and that a large sunflower leaf has 13,000,000.

It is estimated that if all the water given off by the plants of a wheat field in the growing season could be put back on the land again, it would cover the ground to a depth of about four and a half inches, while that given off from the plants of a field of oats would cover the ground to a depth of five inches. It is estimated that from one twelfth to one eighth of the total annual rainfall in the Central states passes out through evaporation from the soil. This shows that a wide margin of safety exists for the farmer who handles his land so as to conserve the water.

**34. Weeds waste water.** It is estimated that an acre of land covered with sunflowers will lose in a season, through these plants, 392,040 gallons of water, which would cover the ground to a depth of one and one-fifth feet and would be sufficient to irrigate about one acre of alfalfa through the season. In every farming region thousands of acres of weeds are constantly sending the precious ground water into the air throughout the growing season, and this water is often needed by our farm crops.

**35. How organic matter is made.** About 20 per cent of the weight of green plants is organic matter. The two principal groups are the carbohydrates and the proteins. The

carbohydrates, such as the sugars, starches, fats, and oils, and woody fiber, or cellulose, are made only by green plants, and by them only in the green parts, that is, principally, in the leaves.

Under the influence of the sun's rays upon the green material (*chlorophyll*) the carbon dioxide of the air, which enters the leaves through the stomata, is broken up into its constituents, carbon and oxygen. These are then combined with the elements

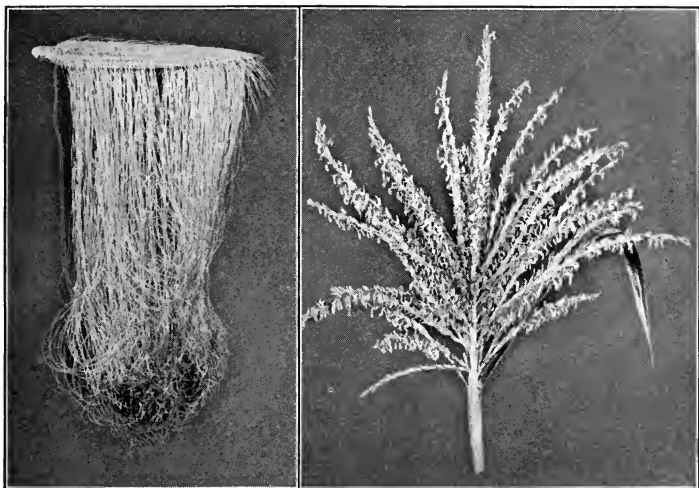

FIG. 16. Seed formation and food storage in corn

Pollen from the tassel (at right) falls upon the silk of the ear (at left), and fertilization results. As the ovules ripen into grains they are stored with food material

which compose water — hydrogen and oxygen. Although the details of this process are not yet fully known, it is known that by successive steps the elements composing water and carbon dioxide — hydrogen, oxygen, and carbon — are built into grape sugar, or glucose, and later into starch; it is also known that much oxygen is released into the air by the work of chlorophyll. Sugar is soluble in the cell sap and is easily transported through the plant to any place where it is needed. The sugar which a corn plant makes can easily be found in the stalk at flowering time. Indeed, if the ears be stripped off, so that the

sugar cannot be carried into them, this sugar can be held in the stalk, and we can secure sugar from cornstalks as from sugar cane.

In some plants, as in the roots of the sugar beet, sugar is stored in quantity, in the form not of glucose but of cane sugar, or saccharose. However, in most plants sugar is not stored but is carried to growing parts, such as the tubers of the potato, the fruit of the banana, or the seeds of corn and other grains, and is there converted, by means of a chemical ferment, or enzyme, into starch. Throughout the plant kingdom starch is the most common form in which the foods are stored.

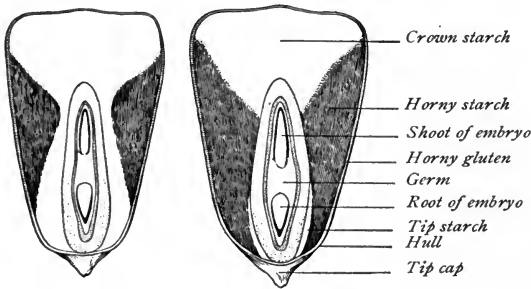

FIG. 17. Diagrams of grains of corn

In some seeds, such as those of the castor bean and of flax, and in the flesh of the olive, foods are stored in the form of fats and oils. These are easily decomposed, while

starch is not easily changed. When needed by the plant the insoluble starch is changed by enzymes, or ferments, into soluble sugar, which is then carried into the growing parts of the plant.

Another important form of carbohydrates is cellulose, or woody fiber, which constitutes the framework, or skeleton, of all plant cells. Cellulose is the most stable form of organic matter. This is seen in the power of wood to resist decay. The stems of plants are rich in cellulose and are the last parts of the plant to decay. When eaten by animals, stems are digested less completely and with greater difficulty than grains and leaves.

In general, the great food storehouses of plants are their seeds (Figs. 16 and 17), in which the foods are deposited and in which the new plant lies embedded. Man has taken advantage of this storing habit of plants, just as he utilizes the honey-storing habit of the bee.

**36. The proteins.** Most of the protein is usually made by the time the plant comes into blossom, and is located in the stem and leaves where it was made; but much of it is usually transferred to the fruit or seeds as they develop. Therefore the seeds and fruit are richer in protein than are the straws and hays. A familiar example of vegetable protein is the gluten in wheat. Protein is composed principally of nitrogen, carbon, hydrogen, and oxygen. Some proteins also contain sulphur, and others phosphorus. Proteins are the most complex plant substances known. While the amount of protein contained in most plants is small in comparison with the amount of carbohydrates, it is very important because, together with the mineral elements of plants, it is the source of the growth of all animals. Without protein, animals could not grow.

#### QUESTIONS AND PROBLEMS

1. What factors determine the abundance of the harvest, and how and to what extent may man control each?
2. Give illustrations of farm crops which have been introduced into new climates, and show the results which followed.
3. Why is it important to plant a large piece instead of a small piece of potato?
4. What are the relative advantages of planting four small pieces or two large pieces of potatoes in one hill?
5. What percentage of the whole green corn plant does each group of component substances form? How may this be determined?
6. What are the necessary elements of plant food, and what are their sources?
7. Assuming that the corn plant is a machine which manufactures and uses food material, describe the machine, the sources of the materials with which it works, how it gets these materials, how it changes them, and what the final products are.
8. How does the character of the soil affect the degree to which plants may take up the soil water?
9. Assuming that your school ground is the bottom of a water tank, the side and end walls of which are as high as required for the following problem, how high would the column of water be which is given off in the

growing season by a twenty-acre field of oats? What relation does this bear to your annual rainfall?

10. In what ways might a layer of leaf hairs affect the amount of water within a plant?

11. What is the effect of a growth of weeds upon soil water?

12. Why is starch rather than sugar a more advantageous form for stored food?

13. What is the importance of protein foods? Where is most of the protein of plants stored?

#### REFERENCES

BERGEN and CALDWELL. Practical Botany, chap. ii. Ginn and Company.

BRIGGS and SHANTZ. The Water Requirements of Plants, *Bulletin 284* and *Bulletin 285*, Bureau of Plant Industry, United States Department of Agriculture.

DUGGAR, B. M. The Physiology of Plant Production. The Macmillan Company.

The Weed Factor in the Cultivation of Corn, *Bulletin 257*, Bureau of Plant Industry, United States Department of Agriculture.



## CHAPTER IV

### PLANT PROPAGATION

The soil receives in its bosom the seed scattered broadcast upon it, softened and broken up; she first keeps it concealed therein; next, when it has been warmed by the heat and by close pressure, she splits it open and draws from it the greenery of the blade.—CICERO

**37. How plants are propagated.** Comparatively few of our principal food plants live longer than a single year. Almost a new generation of plants must be produced at the opening of each new season. To understand how plants multiply, therefore, is fundamental to the successful production of crops.

All cultivated plants come from seeds, spores, or from some form of bud growth. Nearly all farm and garden crops are grown from seeds, but only a few of the fruit trees are propagated in this way. The important field crops not grown from seeds are sugar cane, Irish potatoes, and sweet potatoes. Apples, peaches, pears, oranges, and other fruits, with few exceptions, will not come true from the seed, and are therefore propagated by means of bud growth.

**38. How a plant comes from the seed.** In every live seed there is a living plant in an undeveloped state. This is the part of the seed called the *germ*, or *embryo* (Fig. 18). The embryo is usually but a small part of the seed. The bulky part of most seeds consists of food (principally starch and oil), which has been stored by the parent plant. This food feeds the germ, or embryo, while it is sprouting; it also feeds the young plant until

it has developed a root system and unfolded its leaves in the air and light, and is able to get food from the soil and air.

If a grain of corn be softened by soaking it in water for a day or two, the germ can easily be removed. If this germ is planted it will not grow, because it has been robbed of its supply of food and the protection which the seed coats afford. If a bean be soaked in water and then opened, it will be seen that the halves are held together by the central part of the embryo. In fact, the halves are the seed leaves of the embryo, and are much larger and thicker than the rest of the plant because it is in them that the food for the young plant is stored. When these thick seed leaves are removed from the embryo it will not grow well, for the same reason that the corn germ,

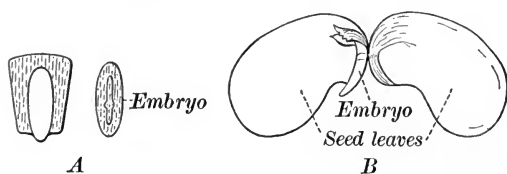

FIG. 18. Corn and bean embryos

A, corn grain with embryo removed ; B, bean embryo

or embryo, without the rest of the grain would fail to grow.

### 39. The embryo.

The embryo, or the undeveloped plant as it exists in the seed before growth begins, consists of

three parts—the seed leaves, or *cotyledons* (Fig. 18), which nourish the young plant ; the bud, or *plumule*, which grows into the stem and leaves ; and the *radicle*, which develops into the root.

**40. Requirements for germination.** Seeds cannot germinate, or sprout, unless they are supplied with moisture, air, and the proper temperature. The first step in germination is the absorption of water. When the stored food in the seed becomes moist and the temperature is favorable, the food is converted into sugar through the activity of ferments, or enzymes. Closely following the formation of sugar, the cells of the embryo begin to swell and grow, and the little plant soon becomes large enough to break the seed coat. Seeds will pass through the first stages of germination even though submerged in water. They soon stop growing, however, and die for lack of air. Death is quickly



followed by decay if the water is warm enough for the organisms of decay to multiply.

Many seeds have such hard or tough seed coats that they require treatment before being planted. This treatment permits the water to enter so that the embryo may begin its growth. Most hard seeds like nuts and the seeds of the peach may be frozen by mixing or layering them with sand (Fig. 19) and leaving them outdoors all winter in an open box, bedded in soil or sand. This is called stratification. Many seeds which do not have hard coats, such as the seeds of most forest trees and those of many shrubs, are benefited by being stratified over winter, as they are thus kept moist and soft. Seeds with rubbery coats like the locusts and the coffee bean are benefited by being stratified, but they are best treated by soaking them in hot water for a few hours just before planting, in order to dissolve the protective covering, which is impervious to cold water. In rare cases holes are bored in such seeds as the canna and the water chinquapin

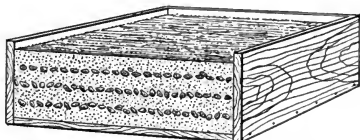

FIG. 19. Device for treating heavy-walled seeds

The seeds are layered or stratified in the sand and left out of doors during winter

to admit the moisture necessary for germination. In other cases the outer coat has been dissolved with a mild acid like vinegar, and sometimes even sulphuric acid is used with good effect. Some such treatment may be used to secure quick germination in clover, alfalfa, and cotton seed.

**41. How long do seeds remain alive?** In every live seed certain vital activities are thought to go on constantly, even in ordinary storage. The enzymes which change the stored foods into sugar are more active in some seeds than in others. These activities result in lowering the vitality of the seeds. The vitality of seeds is also affected by their maturity and by the conditions under which they are harvested and stored. Seeds that are harvested before they are ripe lose their vitality in a much shorter time than those that are harvested when mature. Also

seeds harvested in wet weather are likely to be weaker than those harvested in dry weather.

All seeds should be dry when stored, as they can then stand greater extremes of heat and cold without injury. Seeds will retain their vitality much longer if they are stored where the temperature is mild and constant. Plants whose seeds may lose their vitality quickly are rye, corn, wheat, oats, blue grass, millet, onions, cauliflower, parsnips, celery, and lima beans. Some of those whose seeds retain their vitality for a considerable length of time are clover, alfalfa, common bush and pole beans, garden peas, cabbage, turnips, cucumbers, melons, and squashes. White and red clover seeds that had been buried for thirty-five years under several feet of clay have been known to germinate readily; but seeds do not live for centuries, as is sometimes stated.

**42. Seed planting.** A properly prepared seed bed is the best guaranty of a good crop. Seeds cannot germinate without moisture; and water is most readily absorbed by seeds if the soil particles are fine and fit closely against them. The smaller and weaker the seeds, the better the seed bed must be. This is one reason why fine garden and flower seeds are often planted in boxes of specially prepared soil and the young seedlings transplanted to the garden or field.

Seeds must not be planted too deep, and the smaller and weaker they are, the shallower they should be planted. Timothy seeds, for example, should not be planted as deep as corn or lima beans because when planted at a considerable depth they do not contain food enough to support a plant until it reaches the surface. When the ground is cool, early in the spring, all kinds of seeds should be planted only deep enough to obtain the moisture required for germination.

**43. Propagation by bud growth.** A bud is merely a growing-point. Two kinds of bud growth are concerned in propagation—that from visible, or true, buds, such as are seen on the tips and along the sides of young twigs or stems; and that from adventitious buds, which arise from the growing layers of stem, leaf, or root.

Every true bud is capable of forming a new plant like its parent. When a branch containing buds has formed roots and is cut off from the parent stem, a new plant has been produced. The roots are formed from adventitious growth, which takes place in the growing layer (cambium) which lies just beneath the bark. Adventitious growth may also take place aboveground. In this case sprouts form. Sweet-potato slips, the roots of cuttings and layers, the sprouts of old tree stumps, and the water sprouts that form on the trunk and large branches of trees (particularly following heavy pruning) are all from dormant buds, or of adventitious origin. It is known that cutting or wounding a

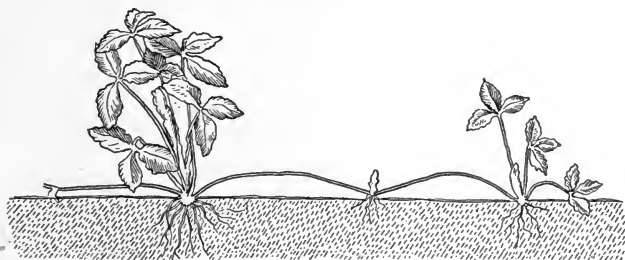

FIG. 20. Strawberry plants started by runners  
The runners develop new plants at the nodes, or joints

plant stimulates the enzymes into activity, and it is probable that these substances are responsible for causing the formation of adventitious buds.

**44. Layers, runners, and root tips.** A layer is a piece of a plant, usually a branch, that has been partly covered with soil to induce it to take root. Many woody plants with branches long enough to reach to the ground can be propagated in this manner; among those most frequently layered are grapevines, ornamental shrubbery, honeysuckles, and climbing roses. To propagate plants by layering, a branch should be covered deeply enough to bring it in contact with moist soil. Layered plants root better if the part of the branch that is to be covered with earth is wounded by twisting, hacking, or scraping, for adventitious growth is stimulated by such wounds.

Plants like currants or gooseberries may be propagated by *mound layers* without bending down the branches. Shoots are first wounded near the ground by scraping the bark. They are then covered with soil to a depth of six or eight inches. Roots form in or above the wounds, and this newly rooted portion may be transplanted and thus become a new plant.

The common house rubber plant is propagated by *pot layering*, or by wounding a branch severely and binding a mass of soil or florist's packing moss (sphagnum) over the wound, and keeping



FIG. 21. Cuttings of geraniums

Such cuttings soon take root if planted in moist sand



FIG. 22. A rooted leaf cutting of rex begonia

The leafstalk has been buried in moist sand, where it took root

the soil or moss moist by frequent watering. Roots form in about six weeks. When the new plant is rooted, it may be cut off and planted.

Plants like strawberries (Fig. 20) form special shoots called *runners*, which creep along the ground and take root usually at the joints, or nodes. A new plant grows from each rooted portion. This plant may be removed when it is large enough for transplanting.

Black-cap raspberry plants are propagated by means of *root tips*. In late summer, as the long branches bend over with their weight and reach the ground, the ends become much enlarged by the storage of an extra supply of plant food in them, and a strong terminal bud is formed. Upon touching the ground the end curves upward, and just back of the curve, if the soil is moist, roots form and a new plant becomes established.

**45. Propagation by separation and division.** Excellent examples of propagation by separation and division are to be

found in bulbs (like the hyacinth and tulip), and in the rootstocks of the canna or in the crowns of the lily-of-the-valley. Bulbs may be wounded by hollowing out the lower part, thus causing a large number of little bulbs to form. These smaller bulbs are taken off and cultivated for from four to eight years, when they will produce good flowers. As for the rootstocks, they are merely broken (or cut) into pieces, care being taken to see that each part contains a bud from which a new plant may grow.

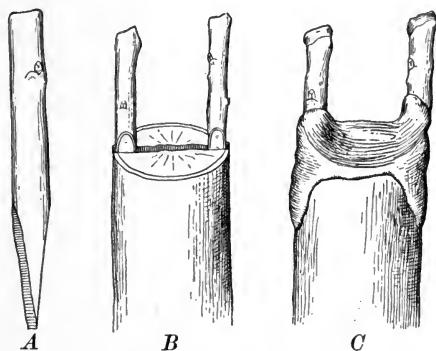

FIG. 23. Stem grafting

*A*, a cleft graft, or scion (usually cut about four to six inches long); *B*, grafts set so as to come in contact with the growing tissues of the stock plant; *C*, the wound covered with grafting wax, to protect against infection and drying or other injury

**46. Propagation by cuttings.** Many plants may be cut into pieces, and each piece caused to take root and thus to form a new plant. The last season's growth of grapevines and of most ornamental shrubs can easily be made to root in this way.

Bedding plants like geranium (Fig. 21), coleus, and heliotrope are propagated by means of pieces of the stem known as green or softwood cuttings. This method is employed extensively in propagating bedding and other ornamental plants.

Blackberry roots may be dug up in the fall, cut into three-inch pieces, and stored like grape cuttings. In the spring these root cuttings may be planted in open furrows.

Plants with fleshy leaves like the rex begonia (Fig. 22) are propagated from leaf cuttings. The leafstalk is buried, and the leaf is laid flat upon the sand. The leaf should be wounded by cutting the veins, or ribs, and should be weighted down with pebbles or pinned to the sand. When the new plants are rooted, they should be treated like geranium cuttings.

Cuttings are made from tubers, such as those of Irish potatoes, by cutting them into pieces so that each piece contains one or two buds, or "eyes." Sprouts arise from the buds, and these quickly form roots and later special shoots which enlarge into potatoes. The fleshy roots of sweet potatoes are planted whole or split in halves. By means of adventitious growth, sprouts arise from toward the stem end and roots from the other end. The sprouts form roots of their own when they are "pulled" off and set in the garden or field.

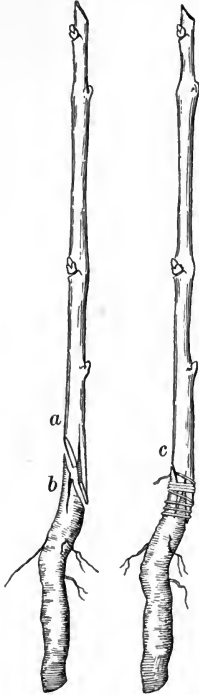

FIG. 24. Piece-root grafting

*a*, scion; *b*, rootstock; *c*, scion and rootstock joined and wrapped with waxed cord for protection

**47. Grafting.** If a hundred apple seeds of some standard variety were planted, it is highly probable that none of the seedling trees would produce fruit that would be like the parent in color, quality, or the season of ripening. The flowers of fruit

trees have been cross-pollinated from time immemorial, and the seed possesses characters from a long line of ancestors; hence trees which grow from seeds rarely show the desired quality of the immediate parents. Fruit trees are commonly propagated by grafting, but they may also be propagated by budding.

Grafting consists in making a twig from one tree grow upon the root or stem of another tree.

Only those plants which are closely related botanically can be made to grow readily upon another. Apples are grown upon apple stock (Figs. 23 and 24). Apples make a feeble growth upon pear or wild crab, these plants being distantly related to the apple. Except under the most skillful manipulation, apples will not grow on trees not closely related, such as the peach, plum, oak, or osage orange. The pear grows best upon pear stock, but will also do well upon quince, a closely related species. Dwarf pear trees are produced by grafting or budding upon quince roots. Apples may be dwarfed by grafting them upon the Paradise apple tree, a natural dwarf which comes from France. Apple and pear trees of any size may be top-grafted in early spring before growth begins (Fig. 25). By this means an undesirable variety may be changed to a desirable one.

Bridge grafting consists in bridging over injured places, as in the case of trees that have been girdled. The girdled portion is bridged by using long scions, which are inserted beneath the bark, above and below the wounds. The scions should be two inches apart all around the tree, and all wounds should be sealed with grafting wax.

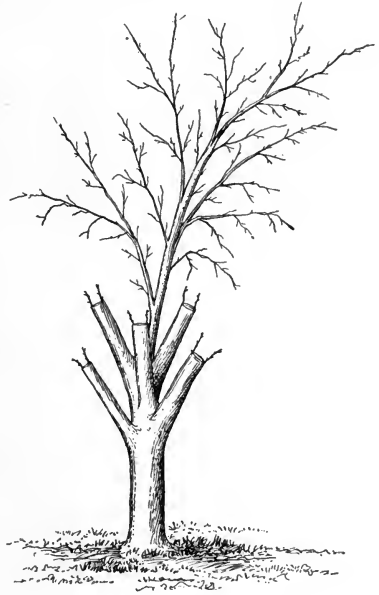

FIG. 25. Top grafting

One branch of the young tree is left, to manufacture food for the tree while the grafts are getting started. When the new growth is well started, the old branch is removed

**48. Budding.** Budding (Fig. 26) is a process much like that of grafting. In grafting, a small twig containing several buds, known as a scion, is employed; while in budding, a single bud is removed from one plant and caused to grow beneath the bark of another plant. The stone fruits, such as the peach, plum, cherry, apricot, and nectarine, are propagated by budding instead of by grafting. Ornamental plants like roses and lilacs are

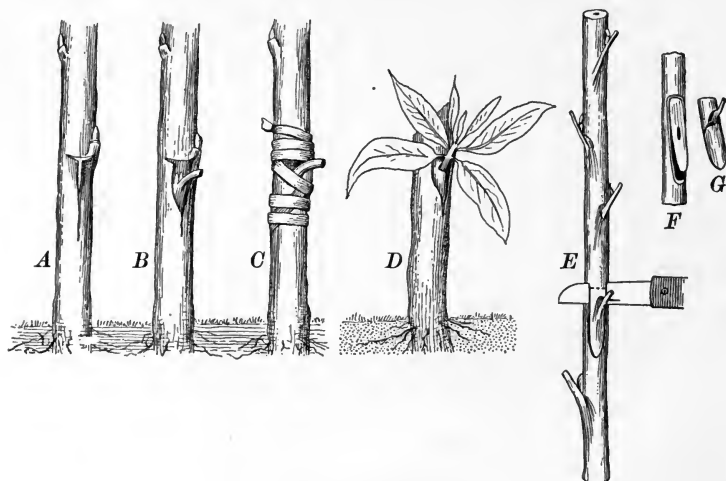

FIG. 26. Budding

*A*, bark cut to receive bud, as shown at *B*; *C*, bud fastened in place; *D*, growing bud; *E*, *F*, *G*, showing method of preparing the bud for insertion

often budded upon other plants in order to secure greater hardiness. Trees with thick bark, like the nut trees, are propagated by budding.

In budding, a three-pointed slit (Fig. 26) is made and a piece of bark bearing the bud of the desired kind of plant is inserted into this slit. Sometimes a ring of bark is removed from the stock and a similar ring bearing a bud is inserted in its place. Great care must be used to insure that the living bark of the bud and the living bark of the stock are placed and held in close contact. The remainder of the process and the results obtained are practically the same as in fruit trees.



## QUESTIONS AND PROBLEMS

1. Under what conditions for germination may the largest percentage of young plants be expected?
2. Why is it that some thick-walled seeds, as those of the cocklebur and honey locust, may lie in the ground for several years before germinating? How could germination be hastened?
3. Prepare a list of a dozen common farm and garden seeds and state the depth at which, under ordinary conditions, the best germination may be expected.
4. What conditions determine the length of life of a seed?
5. When are seeds said to come true?
6. What are the disadvantages of planting seeds which do not come true? How are these disadvantages avoided?
7. Prepare a chart, giving the different methods of propagation, naming a plant propagated by each method, and describing how the plant is treated in each case in order to propagate it.
8. Of what particular value to man is plant propagation?

## EXERCISES

1. **Stored food of seeds.** Examine a dry grain of corn. Locate the heart, or germ. Soak a few grains of corn overnight or until softened. Remove the skin, or seed coat. Is the germ, or heart, united to the remainder of the seed? Carefully remove the germ and plant it and the rest of the grain in wet sand between cloths. Observe every day and note results. Is all of the grain alive? Plant some grains of corn that have been soaked for a few hours. When roots have begun to form, carefully remove the main part of the seed and plant again. Plant by the side of seeds that have not been disturbed. Explain results.
2. **Cotyledons.** Examine a dry lima bean. Locate the germ. Soften some beans by soaking for a few hours. Plant one-half inch deep, and when they begin to grow, carefully remove the two large seed leaves. Keep accurate measurements of the rate of elongation of both kinds of seedlings, and thus determine the value of the food stored in the seed coats.
3. **Relation of air to germination.** Drop ten lima beans into a glass of water. After twelve or fifteen hours examine. Observe again at the end of twenty-four hours. Why did germination cease?

**4. Necessity of moisture.** Plant ten grains of corn between pieces of cheesecloth in soil or sand that is quite dry. Plant ten grains between cloths in moist sand. Examine both lots after twenty-four hours and again after forty-eight hours, noting and explaining progress in germination.

**5. Temperature requirements by different seeds.** Plant ten seeds each of corn, wheat, rye, barley, rape, cowpeas, cabbage, tomatoes, onions, and beans between pieces of cheesecloth in moist sand, and place in a laboratory oven or in a home-made plant box heated with a kerosene lamp so that the temperature can be kept between 90 and 100 degrees F. Prepare another set of the same kinds of seeds, but keep them in a room where the temperature is about 70 degrees F. Another set may be kept in a cool cellar. A fourth set may be kept in an ice box. Keep a daily record of the progress in germination of the different kinds of seeds, and explain the results.

**6. Effect of depth of planting on seed germination.** Plant sets of Irish potato and seeds of timothy, radish, onion, corn, and salsify one, two, four, and eight inches deep, respectively, in a box of moist soil. Observe the number of plants of each that appear above the ground.

**7. Layers.** In early spring, before the leaves come out, the rose, lilac, and other small shrubs may be layered. Scrape off the bark on the underside at the point where the branch is to be buried. Open a trench four or five inches deep and a foot long, bend the branch down into it, and replace the soil. A few inches of the tip of the branch must be aboveground. By autumn the layer may usually be cut off and planted elsewhere. Old branches sometimes require two seasons in which to produce a good root system.

**8. Mound layers.** Mound layering is done in early spring before growth begins. Select a currant or gooseberry plant for this experiment. Scrape half of the bark from the lower three inches of all sprouts. Place soil around the plant five or six inches higher than the wound, so that the wounded parts will be moist throughout the summer. In late autumn the newly rooted plants may be transplanted.

**9. Hardwood cuttings—grapes.** In late fall select a new branch from a grapevine, cut it into pieces about fourteen inches long, the bottom cut being just below a node, or joint. Each cutting should contain at least two nodes, preferably three. Tie into a neat bundle and pack in fresh sawdust from green logs, or in slightly moist sand.

A layer of packing material at least two inches thick should entirely surround the cuttings. Store in a cool cellar where they will not freeze, or bury them out of doors in a well-drained soil.

In the spring the cuttings should be planted in well-prepared soil, standing the cuttings on end and packing the soil firmly against them. Only the top buds should be aboveground. After one season's growth the vines may be transplanted to their permanent location.

**10. Softwood cuttings.** Softwood cuttings, such as geraniums and coleuses, root best in moist sand. At first, keep the cutting box in a shaded place, at a temperature not below 40 or 50 degrees F., and preferably about 70 degrees. Cut the plant stems into pieces three and one-half inches long. Trim off all leaves except one or two at the top of the cutting. Plant four inches deep. Shade from the sun for a few days with old papers. In a week or ten days carefully dig up. If not rooted, plant in the sand again. The stems with roots an inch long should be set in two-inch flower pots in very loose, rich, sandy soil. If the schoolroom is not kept above freezing at night, the cuttings may be grown in a simple wooden plant box, heated with a common oil lamp.

**11. Apple root-grafts.** In the fall or winter mix apple seeds with moist sand in a box. Place the open box on the ground on the shady side of a building and let it remain out all winter. In very early spring, before the seeds begin to sprout, they should be planted, sand and all, in a deep, fertile garden soil. Cover an inch deep or less. Cultivate through the summer. In autumn, after a heavy frost has caused the leaves to fall, dig up the seedlings with the entire tap root. Store in a cool cellar in green sawdust. In early November collect from apple trees of suitable varieties three times as many scions as there are seedling roots. Select only twigs that grow on the ends of the limbs. This is the wood that grew the previous summer. Well-matured water sprouts that grow up in the tree will do. The scions must be six or seven inches long. Pack in green sawdust. In January or February graft the scions on the seedling roots. Cut the roots into pieces three and one-half inches long. With a sharp knife slope the upper end of each piece. On the face of the cut, split the piece down for an inch from the end to form the tongue. On the base of each scion make a sloping cut and tongue, exactly as on the roots. Fit the scions and the roots together by causing the tongues to interlock. The cambiums must be in contact on at least one side. Wrap securely with

No. 20 cotton knitting thread. Pack the finished grafts in sawdust until spring. At gardening time plant the grafts on end in rich soil, packing the soil securely about them. Only the top bud of the scion should be left aboveground. Cultivate the grafts through the summer, and by fall the trees should be large enough to plant in the orchard or they may be left to grow another season before transplanting. These trees will bear the same kind of fruit as the trees from which the scions were taken.

#### REFERENCES

- BAILEY, L. H. *Cyclopedia of American Horticulture*. (See *Bulbs*, pp. 189-195; *Cuttage*, pp. 420-423; *Layering*, p. 894; *Graftage*, pp. 659-665; *Seedage*, pp. 1640-1647.) The Macmillan Company.
- BAILEY, L. H. *The Nursery Book*. The Macmillan Company.
- DUVEL, J. W. T. *Vitality and Germination of Seeds*, *Bulletin* 58, pp. 87-90, Bureau of Plant Industry, United States Department of Agriculture.
- FULLER, A. S. *Propagation of Plants*. Orange Judd Company.

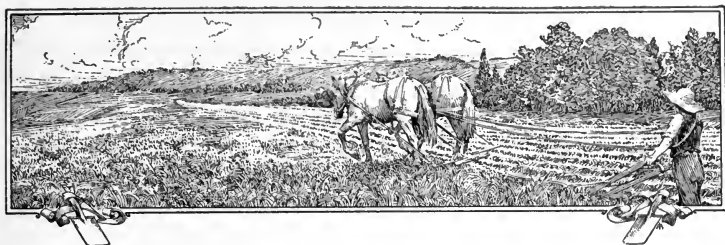

## CHAPTER V

### THE SOIL AND ITS MANAGEMENT

We may be wasteful and careless of everything else ; but the land belongs to the Ages—it is ours but for the brief period which marks the passing generation. We are trustees holding this land a sacred trust for generations yet unborn ; and the happiness, the comfort—yes, the very existence of our children's children and the millions who will follow, is dependent upon the conscientious, far-seeing wisdom with which we discharge this solemn trust. — WILLIAM C. BROWN, formerly president New York Central Railway, before the Page County (Iowa) Boys' Agricultural Club, May, 1910

**49. The soil, man's chief asset.** The nation's greatest asset is the soil. Until recent years, however, farmers gave little serious thought to the use of this great wealth. Men have recently studied the soil and learned ways of handling it which have yielded greater profits. The farmer who grows crops scientifically nowadays considers the value of manures, humus, soil bacteria, crop rotation, and the conservation of moisture and plant food.

**50. What soil is.** Soil is the more or less finely broken rock material which covers the land areas of the globe, plus organic matter resulting from decay of plants and animals (Fig. 27). Agriculturally speaking, the soil is the surface layer of this mass. The subsoil is that part of the soil lying between the surface soil and the underlying rocks. It is underlain by rocks at depths varying from a few inches to many feet. The organic material in various stages of decay gives to the surface soil its dark color in contrast with the light color of the undersoil, or

subsoil. The surface soil varies in depth from a few inches to several feet, and is usually coarser and more friable and much more productive than is the subsoil. Other things being equal, the deeper the layer of surface soil, the more productive it is.

**51. How soil is formed.** Soil is formed by the breaking of rocks through the action of the weather and water. No exposed rock surface is free from the effects of weathering. Highly polished granite blocks lose their luster after considerable exposure. The minerals which compose the rocks are transformed into a powdered mass, and some of them may also undergo a more or



FIG. 27. How vegetation helps in soil building

less complete chemical change. The action of rain water dissolves some of these materials, while the finer particles may be washed entirely away or carried down into lower layers. This explains why the subsoil in humid regions is usually of finer texture than the surface soil.

Various weathering agencies are concerned in the process of breaking down rocks (Fig. 28). The change in temperature causes rocks to expand and to contract, producing small cracks in the rock surface, into which water enters. When the water freezes it exerts a strong force which widens these cracks, and thus hastens the breaking down of the rock. Certain of the mineral substances in the soil are affected by oxygen as iron oxidizes, or rusts, under the influence of air and moisture. Rain water takes up carbonic-acid gas in its passage through the air, and this makes it very much more effective in its action upon the rock minerals than is water containing no carbonic acid. This carbonated water not only aids in dissolving certain rock substances but also brings about chemical action whereby

certain of the minerals are decomposed and new substances are formed. For instance, a mineral called feldspar, a common part of rocks, is decomposed under the influence of water containing carbonic acid, and forms clay and other products. Most of our clay soils are made in this way. As rocks break down, the soluble material is dissolved by water and carried by streams to the sea, where it constantly helps to supply the salts of sea water.

The fact that little actual breaking down of the rocks can be observed during a lifetime goes to show the extreme slowness with which these weathering processes go on. A stone building stands in the weather for a hundred years with only a slight roughening of the rock surface.

#### 52. The mineral matter of soils.

The mineral matter of a soil makes up the larger part of its weight, the organic matter being usually less than 5 per cent of the total weight.

From the mineral matter most of the plant foods are derived. This mineral matter varies in texture from coarse gravel to fine clay. The finest of these clay particles are so small as to be visible only with the highest-power microscopes. It would require 25,000 of these minute clay particles, laid side by side, to measure 1 inch in length. For sandy soils or loess it would ordinarily require from 500 to 1000 soil

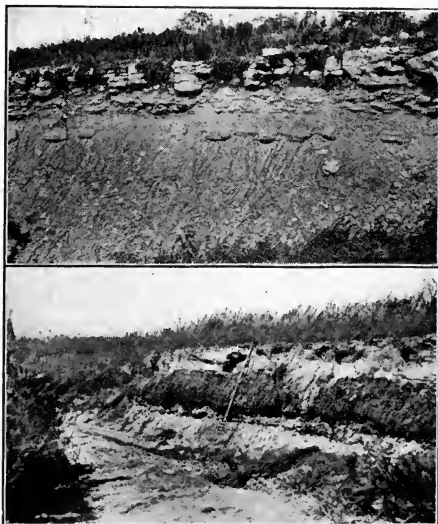

FIG. 28. How soils are formed

In the upper picture, a ledge of partly disintegrated limestone is shown. Roots are growing in the crevices of the rock, thus assisting weathering agencies in reducing the rock to soil. In the lower picture, clay and loam have been formed. The roots penetrate through these to a depth of several feet

particles to measure an inch. As soon as the rock mass is broken fine enough to support the lower forms of plants, organic or vegetable matter<sup>1</sup> begins to accumulate. The lower plants, such as lichens and mosses, are followed by higher forms, whose decaying substance is the main source of the organic matter of new soils.

**53. Kinds of soils.** Soils are classified according to the way in which they are formed. There are two general classes: *sedentary soils*, or those which have not been moved; and *transported soils*, or those which have been moved by water, wind, or gravity. Sedentary soils may be divided into *residual soils* and *cumulose soils*.

Residual soils are those which remain where they were formed from the breaking down of the rocks. If an excavation be made in the soil material until bed rock is reached, all stages of the process of weathering can be observed. A large part of the soils of the United States is of residual character. Some of these are very good agricultural soils, some are poor, and between these there are all possible gradations. They vary also from fine clays to coarse sands and gravels.

A limestone soil is a good example of a residual soil. Limestone rock is composed largely of calcium and magnesium carbonates, with some other substances, such as silica, iron compounds, and clay. Limestone weathers by the dissolving and washing away of a large part of the carbonate, under the influence of water containing carbonic acid. The substances remaining from the rock form the soil.

Sandstone is nothing more than sand which, during geologic ages, was cemented into a solid mass. Sandstone weathers by the dissolving away of the cementing material which holds the particles together and by the action of freezing water in the pores of the rock. The soil formed consists largely of sand, and is known as sandy soil.

<sup>1</sup> The term *humus* is often used in speaking of the organic matter in soils. Strictly speaking, *humus* is that part of organic matter which has reached an advanced stage of decay.



A granite rock, which consists of quartz, feldspar, and usually mica, is broken down by the action of the weather. Through the decomposition of feldspar and mica, clay is formed. This clay, with the quartz grains of the granite, forms soil. Other rocks are similarly weathered to form coarse-grained, medium-grained, or fine-grained soils, according to the conditions under which the rock is broken down.

The largest areas of residual soils are found in the Southern states, the Appalachian Mountain region, and the Rocky Mountain states. Many of these soils are very productive.

#### 54. Cumulose soils.

Soils formed largely by the accumulation of organic matter in shallow lakes or in channels or arms of rivers are called cumulose soils. The remains of water plants, such as reeds, rushes, and moss, gradually accumulate in such places

and become mixed with more or less mineral matter, and are known as muck, or peat, soils. In the Northern states many old lake beds have been filled with these soils and are now used for growing truck crops, such as celery, onions, and cabbage, while in some cases they are used for growing general crops. When drained, such soils are very valuable, but some require

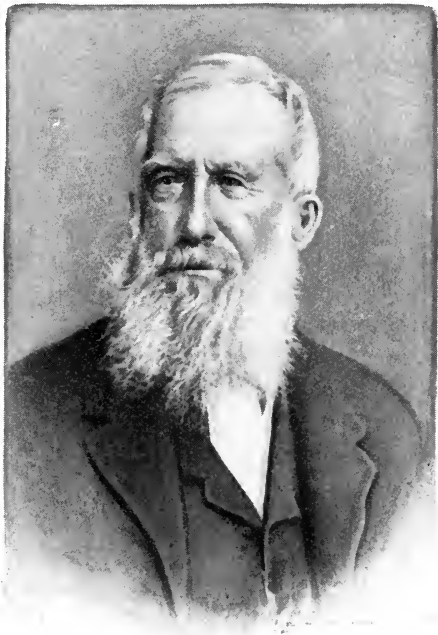

FIG. 29. Sir John Bennet Lawes (1814-1900)

A celebrated agricultural scientist. The founder of the Rothamsted (England) Experiment Station, where a number of noteworthy discoveries in soil management, crop rotation, and animal nutrition have been made

the application of lime and a potash fertilizer to make them satisfactory for crop production.

**55. Transported soils.** Transported soils are usually classified as *alluvial*, *glacial*, *æolian*, and *colluvial*.

Alluvial soils are those laid down by water along streams or in lakes and ponds. The material from which such soils is formed is washed by rains from the higher land. The muddy water running from hillsides during heavy rains and the muddy water seen in all streams during high water are the result of the washing away of the soil of the higher lands. During high water, as the streams spread over the bordering lowlands, material is deposited, forming the deep soils commonly known as bottom lands. Alluvial soils, when properly drained, are usually very fertile, because of their depth and the fact that they are formed from the rich surface soil of the uplands. There are large areas of such soil along the main rivers of the United States, particularly along the Mississippi, the Ohio, and the Missouri. The large lowland region of Louisiana bordering the Mississippi River, known as the delta region, is made up of material carried by the river.

**56. Glacial soils.** Glacial soils are formed by the action of moving ice. A considerable share of the soils of Canada and the northern part of the Mississippi Valley are of glacial origin. The Missouri and Ohio rivers represent approximately the southern edge of the area of glacial soils in North America. There are small areas in the Rocky Mountains, but these are not of great agricultural importance. These glacial soils were formed centuries ago when the climate of North America was much colder than it is now and when the northern part of the continent was covered with a layer of ice which moved slowly down from the North, grinding the rocks beneath it, leveling the hills, and filling the valleys. As the ice melted, it left a mass of pulverized rock material which now forms these glacial soils. The most important large body of agricultural soil in the United States, that of the North Central states, often known as the corn belt, is of glacial origin.

**57. Æolian soils.** Æolian soils are deposited by wind action. Soil may be drifted by the wind, just as snow is drifted. Most of the prairie soils in the Western states have been more or less affected in their formation by the action of the wind. In a few localities a sedentary soil has been covered to a depth of several feet by fine sand which the wind has carried. There is an important type of æolian soil known as loess soil, which is believed to have been formed in part by wind and in part by water. An interesting example of loess may be seen along the Mississippi and Missouri rivers and is frequently called "bluff" soil. It is yellowish brown in color, well aerated, very deep and fertile, and therefore particularly favorable for growing all kinds of fruit. The greatest areas of it occur in western Missouri, western Iowa, and eastern Nebraska. A very important area of loess soil is found in China.

**58. Colluvial soils.** Colluvial soils are those which have been moved but a short distance. They occur principally at the foot of mountain slopes, where they have been formed by the soil sliding or washing down the mountain side. This soil is so small in area as to be of little agricultural importance in North America, but some of the important vineyards of Europe are of this type.

**59. Significance of soil type.** The glaciers rendered a splendid service to civilization not only in grinding the rocks into powder and leveling the earth's surface, but also in transporting the fine soil material from the frozen North and spreading it over the wheat and corn belts. Of the sedentary soils the limestone supports the highest type of agriculture. Sandy soils are generous, but do not have the lasting powers of the limestone soils. Granite soils are stingy, and on account of this they wear well. Alluvial soils are the most productive of the transported soils, and indeed of all soils, but they are more or less subject to flood and frequently require drainage. As a rule the bottom lands are not as satisfactory places in which to live as are the uplands.

## QUESTIONS AND PROBLEMS

1. In the classification of soils given below, answer each of the questions asked.

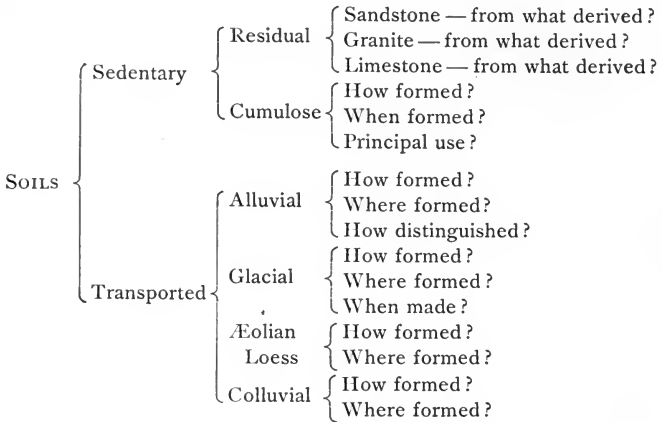

2. How does rain water assist in forming and in modifying soil and subsoil?

3. How does the oxygen of the air aid in soil forming?

4. How can you distinguish soil from subsoil? Can you make similar distinctions in freshly washed sand or in blown sand?

5. Where does the mineral matter in soil come from?

6. What use of the mineral matter is made by the plant?

7. What proportion of the soil does mineral matter constitute?

8. What is the source of organic matter in soils?

9. Is soil carried by air currents? Can you answer this by placing an oiled glass surface so that it is exposed to the air for a few hours? Why use an oiled surface?

## EXERCISES

1. **Study of soils in the field.** Collect samples of limestone, sandstone, and granite soils. Can you locate soils which came chiefly from each of these kinds of rock?

2. **Classification of neighboring soils.** Make an excursion to the field, and study as many kinds of soil as possible. Study soils in the making, along streams, bluffs, or railroad cuts. Classify the soils examined as to the method of formation, such as residual, cumulose,

glacial, alluvial, æolian, or colluvial. Determine the depth of the surface soil and the subsoil in each case, the character of the drainage, general texture, character of subsoil, and probable agricultural value. Compare the soil in an old cultivated field with that of a rich garden or a fence row. Note the respects in which they differ.

**3. Vegetation and soils.** Study the character of the native tree and weed growth on different soils and slopes and note how they are related to the agricultural value of the soil.

**4. Character of layers of soil.** Equipment: spades or shovels, 1½-inch auger with 3-foot gas-pipe extension and a T-handle. Two squares of oilcloth 15 × 15 inches.

By means of the soil auger, bore to the depth of the soil, depositing the borings carefully on the oilcloth. Note the difference in the color of the soil and subsoil; note the lack of organic matter in the subsoil. Compare the texture of soil and subsoil between the fingers. Take samples of the soil to the laboratory and compare them with the standard types of sandy soils, loams, sandy loams, silts, and clays, in order to determine more accurately the texture and classification. If your laboratory possesses a microscope, or even some good hand lenses, examine the soils from different depths under magnification.

#### REFERENCES

- FLETCHER, S. W. Soils, chaps. i and ii. Doubleday, Page & Company.  
HOPKINS, C. G. Soil Fertility and Permanent Agriculture, chaps. i-vi. Ginn and Company.  
KING, F. H. The Soil, chaps. i and iii. The Macmillan Company.  
LYON, T. L., and FIPPIN, E. O. Principles of Soil Management, pp. 1-68. The Macmillan Company.  
THORNE. Farm Manures, chap. 1. Orange Judd Company.  
VIVIAN, A. First Principles of Soil Fertility, chap. v. Orange Judd Company.  
WHITSON and WALSTON. Soils and Soil Fertility. Webb Publishing Company.



## CHAPTER VI

### THE PROPERTIES OF SOILS

Some advise to mix together earths of different qualities; for example, light with heavy, and heavy with light; fat with lean, and lean with fat; in like manner, red and white, and whatever has contrary qualities. Because this mixture not only supplies what is wanting but also renders the soil with which another is mixed more powerful, so that what is worn out, being mixed with a fertile kind of earth, begins again to carry crops as if renewed, and what is naturally barren, as clay, if mixed with another, in some measure serves in the place of manure. — THEOPHRASTUS

**60. Soil texture.** The term *soil texture* refers to the size of the particles of which soil is composed. Most soils consist of particles varying in size from coarse to fine, although some soils contain only coarse, and others only fine, particles. The coarse particles are called fine gravel or coarse sand, and the next finer, medium sand; then follow fine sand, very fine sand, silt, and finally clay. The relative amounts of these different grades vary widely in different soils. A soil of coarse texture is one in which the coarser particles predominate; a soil of fine texture is one in which the fine particles predominate (Fig. 30).

Soils containing a large proportion of sand are also called sandy soils; those containing a large proportion of clay are called clay soils; those which are intermediate, between coarse and fine, are called loam soils. A loam soil with a slight excess of clay is called a clay loam; a loam soil containing much silt is called a silt loam. Various other names are applied to soils of different textures, such as coarse sandy loam, fine sandy loam,

gravelly loam, and silty clay. In the reports of the state and national soil surveys, certain proper names are prefixed to describe certain types of soils, as Hagerstown Loam, Marshall Silt Loam, Salem Sand, and Miami Clay Loam.

**61. The weight of soils.** The coarser the soil is, the less the pore space of the soil and the greater the weight per cubic foot. A cubic foot of dry sandy soil weighs from 100 to 110 pounds; of loam, from 80 to 90 pounds; and of clay soil, from 60 to 70

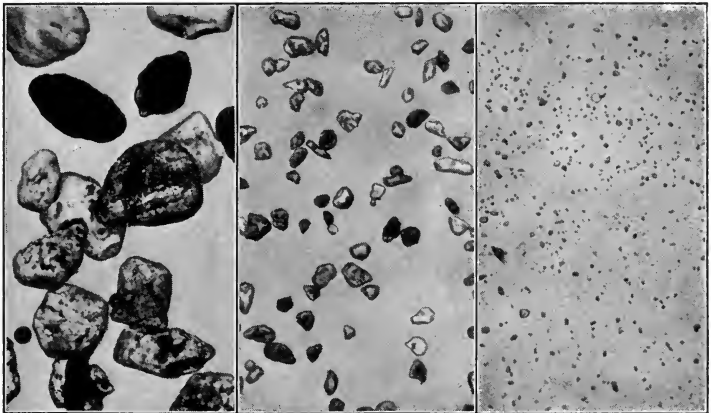

FIG. 30. Textures of soils

Coarse sand (at left), fine sand (in middle), and silt (at right) under the same magnification. Particles of clay are so small that they are not visible under the magnification used. (Photographs by Throckmorton)

70 pounds. The farmer, however, refers to a heavy soil as one which is hard to work, such as a clay soil or a clay loam. These soils work hard because they are fine grained. They are plastic when wet and become very hard when dry. A sandy soil, on the other hand, would be called a light soil by the farmer because it is easy to work. Therefore, that which the farmer knows as a light soil is really one which has a heavy weight per cubic foot, and what he classes as a heavy soil is one which is light per cubic foot. It is also true that the greater the amount of organic matter in a soil, other things being equal, the less it weighs.

**62. Soil texture as related to crop growth.** The reasons for the success of certain crops on certain soils are not yet fully understood. The soil texture, however, is one of the most important factors determining crop adaptation. Truck crops are especially adapted to sandy loam soils, as potatoes, melons, and peanuts. Fruit trees require a deep, well-aired soil. Corn is better adapted to a loam soil. Small grains, such as wheat, oats, and barley, as well as some of the most



FIG. 31. Soil in good physical condition

important grasses, as timothy and blue grass, are usually better adapted to fertile clay loams or silt loams. The fact that crops are best adapted to certain soils does not mean that they cannot be grown on other soils; but where the conditions are not entirely satisfactory, a plant must usually be modified to suit the soil, or the soil modified to suit the plant before the best results can be obtained. On the average farm it is usually necessary to grow a variety of crops, but it is a part of the farmer's business to select crops which can be produced with the greatest net return



on his particular land ; also to modify the land in some cases by manuring, liming, or special systems of culture, in order to fit it better for the crops to which it is not naturally adapted. Agricultural soils are usually loams or sandy loams, and most of our important farm crops can be made to grow well on such soils.

**63. Soil structure.** The term *soil structure* refers to the manner in which the particles are arranged in the soil. A soil with its fine particles gathered together in granules is said to



FIG. 32. A badly cracked soil

A heavy soil badly cracked as the result of drying after having been saturated for a long time

have a granular, or crumb, structure, and is loose and friable. Such a soil is frequently said to have a good physical condition, or good *tilth* (Fig. 31). On the other hand, the small particles may be compacted together in such a way that these granules are broken down. In this case the soil is compact and is said to have a poor physical condition, or a poor tilth. The way in which a soil works when it is turned by the plow — that is, whether it crumbles or breaks up into clods — is determined by its structure and condition.

**64. Causes of poor physical condition.** There are several causes of poor physical condition. Working the soil when it is too wet breaks down the crumb structure and compacts the particles. If plowed wet, hard clods form when it dries. A heavy beating rain falling upon a soil that has been worked very fine often brings about a compact structure at the surface, and if such soil dries rapidly, a hard crust will form (Fig. 32). When the supply of organic matter is greatly reduced, as is the case with much old and improperly farmed land, it becomes compact and loses its friable condition, or its good tilth.

**65. How a poor physical condition may be improved.** The things which tend to bring a compact soil back into condition are (1) fall plowing in the Northern states, by which the soil is exposed to the winter's freezing; (2) working into the soil organic matter, such as stable manure, or green manure;<sup>1</sup> (3) better drainage; (4) the addition of large quantities of slaked lime; (5) seeding the land to grass for three or four years. The alternate wetting and drying of a soil resulting from repeated rainfall is also important in loosening a compact soil.

The things which tend to keep soils in good physical condition are (1) working them only under proper moisture conditions; (2) maintaining the supply of organic matter; (3) thorough drainage. Soils of fine texture are difficult to keep in a friable condition. Sandy soils or sandy loams can be plowed earlier in the spring and worked with much more water in them than can clay loams or clay soils. Similarly, soils containing much organic matter, as sod land, can be worked earlier and with more water in them than can stubble land. The ease with which a soil can be tilled is therefore a matter both of texture and of condition. The ease of tilling a soil is sometimes more important than its fertility.

**66. Color as an indication of value of a soil.** A black soil, with few exceptions, is a fertile soil. The color indicates the presence of plenty of organic matter, and this usually means an

<sup>1</sup> A green-manure crop is a crop, such as rye, clover, or peas, turned under for the purpose of enriching the soil in organic matter.

abundant supply of available plant food. A soil with a bluish shade indicates poor ventilation, usually due to poor drainage. This bluish color is due to the fact that the iron compounds are not well oxidized because of lack of air. When such soils are aerated by thorough drainage, the color changes to a dark brown or red, depending upon the amount of organic matter and iron present. Usually red or brown soils give up their plant food readily to crops. They are therefore known as generous, or responsive, soils. Such soils are usually well adapted to clover, wheat, and fruits. For the most part, the red soils of the country are limestone soils, containing considerable iron, which has been oxidized to iron rust through good drainage and aëration. The organic matter is readily depleted in these soils by cultivation, and they are likely to need organic matter and phosphates. Brown soils contain more organic matter and are usually somewhat more fertile than red soils. The so-called chocolate loams are famous for their agricultural value. Soils of a gray color are among the lowest in productivity.

**67. Plant growth as an indication of soil fertility.** One of the best indications of a soil's fertility and value is the character of the growth upon it. Rank, dark-green plants usually indicate an abundance of organic matter and available nitrogen. Vegetation of a pale-green color, lacking in luxuriance of growth, generally indicates a lack of organic matter and available nitrogen. Timber growth of softwood species, as basswood, walnut, and papaw, indicates a fertile soil, well adapted to grain crops and clovers. Large white oaks, hickory, and hard maple indicate soil of medium fertility. Beech usually indicates poor land, as do pines and most other cone-bearing trees. Swamp or water oaks and red maple indicate poor drainage. An abundance of legumes indicates a soil which contains plenty of lime, and is well drained. The absence of legumes and the presence of sorrel, dock, and horsetail indicate lack of lime and poor drainage. The presence of shrubs like the huckleberry, blueberry, and cranberry, and of such trees as the chestnut and pine, indicates poor drainage, and soil that is low in lime.

**68. The supply of soil water.** The supply of water in the soil is the most important of the factors controlling the yield of crops. Water is not only the chief food of plants but it is the carrier of other plant foods which come from the soil. The proper control of soil water, therefore, is one of the most important considerations in profitable soil management. It is necessary to have a soil in such condition that the excess water will readily drain away, while the soil retains the amount necessary to the proper growth of crops.

The pore space in the soil is from 30 per cent to 60 per cent of the volume. About 50 per cent of the volume of loam soil, if in good physical condition, is pore space. When rain falls, the water penetrates first into the large openings, such as cracks and wormholes, then into the finer openings between the particles. When these openings are filled with water, the soil is said to be saturated. The air is thus forced out of the soil, and until a large part of this water drains into the subsoil, so that the air can again enter the soil openings, agricultural plants will not grow. Plants on a saturated soil soon turn yellow, and if the water remains long enough, they will die.

After heavy rains in the spring, water will often rise in a post hole to a point only a few inches below the surface. This shows that the soil is saturated with water almost to its surface. The upper limit of this standing water in the soil is known as the *water table*, and it is only when this water table sinks to a depth of three or more feet below the surface that the soil is in the best condition for crops.

**69. How water is retained in the soil.** After the standing water drains downward in the soil, considerable water is still held in the fine openings as *film*, or *capillary*, water. If a marble is dipped in water and then removed, it will be covered with a film of water. This represents the manner in which film water is held around the particles of soil. If one end of a very small glass tube is dipped in water, the water will rise to a considerable height in the tube. This is what is known as the capillary rise of water, and the finer the opening, the higher the water will rise.

A strip of cloth having one end dipped in water draws the water up into the fine openings between the threads until it becomes moist several inches above the level of the water. These illustrations represent the manner in which the capillary water of the soil is held and drawn up through the fine openings existing between the soil grains (Fig. 33).

**70. The effect of soil texture upon the amount of water retained.** The finer the soil particle, the greater the total amount of exposed surface over which the thin films of water may be spread; also the finer the soil, the more fine openings there will be in which water will be retained by capillary action. Consequently fine soils retain more water for plant use than coarse soils. For these reasons fine soils are often spoken of as moist soils, while coarse soils are spoken of as dry soils. However, a soil may be so fine that much of the water falling as rain will run off, and the rate of movement of water through it is too slow to supply the needs of the plants. Sandy soils, on the other hand, while incapable of holding as much water as those of finer texture, absorb water and give it up to growing plants so readily and completely that they are the most productive soils in regions of limited rainfall.

**71. How water travels in the soil.** During heavy rains water passes rapidly downward into the soil. The water which drains downward by gravity is called *gravitational*, or *free*, water.

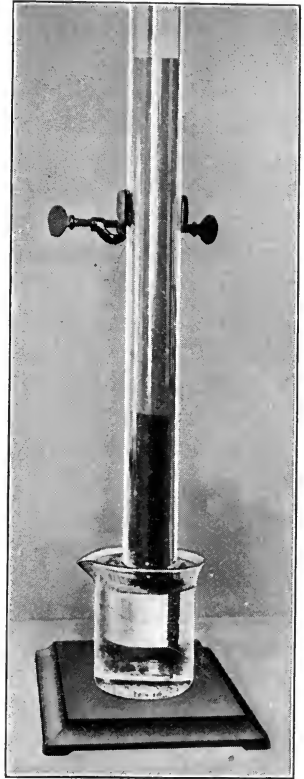

FIG. 33. The rise of water in the soil

A glass tube filled with soil is placed with one end in a dish of water. The water rises slowly in the soil, the moist soil appearing darker than the dry soil

This is the water which forms the water table. The wet, seepy places on hillsides are usually caused by gravitational water flowing along the top of a heavy layer of clay beneath the ground until it reaches the surface on a hillside.

At all times, except when the soil is saturated, there is more or less movement of the film, or capillary, water of the soil. If the subsoil contains less moisture than the surface soil, the capillary movement is downward. If the subsoil contains more water than the surface soil, the movement of capillary water is upward. During the warm summer months the loss of water by evaporation from the surface of the soil is considerable, especially where the surface is not covered with a crop and where no care is taken to check evaporation by proper tillage.

**72. How to save the soil water.** Where the surface of a soil is compacted, the capillary water can move directly to the surface and evaporate into the air. If, however, the soil is stirred or cultivated to a depth of two or three inches, the capillary rise of water will be checked at the point where the cultivated and the uncultivated layers of soil touch, and the loose layer of surface soil will serve as a blanket to retard the evaporation of the water from the surface. This is known as a soil mulch. The principle of soil mulching is employed in the preparation of land for grain crops in all parts of the country, as well as in the cultivation of intertilled crops.

**73. Preserving a soil mulch.** A soil mulch is destroyed by a rain which packs the surface soil. The mulch should, if possible, be renewed by stirring as soon as the soil is dry enough to pulverize. In time a mulch settles together without rainfall, and it should be stirred occasionally, even though no rain falls.

There are times when the surface layer of the soil is porous and dry and it becomes desirable to increase the rise of capillary water. This may be done by rolling, which compacts the soil and brings more particles into contact, thus drawing moisture nearer the surface by capillary action. This treatment may be of importance in hastening the germination of grain. It is usually wise to follow a roller with a harrow within a few days to form the soil mulch again.

**74. Soil temperature.** Few seeds will germinate at a temperature under 40 degrees F.; most seeds require a temperature above 60 degrees F. Most of the beneficial soil bacteria reach their maximum activity and usefulness between 80 degrees and 100 degrees F. Thus the importance of a warm soil is apparent.

The main source of a soil's warmth is the sun. Soils which contain much water warm slowly, because water has a high specific heat<sup>1</sup> and because the evaporation of water from the surface of the soil requires heat. Aside from the season, the water content of a soil is the most important factor which determines its temperature. Wet soils are said to be cold; dry soils are said to be warm. Wet soils become warm late in the spring and are said to be late; dry soils become warm early in the spring and are said to be early. These terms refer to the time when soils can be plowed and planted to crops.

Other factors affecting soil temperature are the slope of the land and the color of the soil. Lands sloping to the south are warmer than those sloping to the north, because of the more favorable exposure to the sun. Other things being equal, dark soils absorb more heat than light soils.

The methods for modifying soil temperature are mainly those of controlling the water supply. The draining of cold, wet lands warms them. Increasing the content of organic matter in warm, dry, sandy soils, thus causing them to retain more water, tends to keep them cooler. Tillage warms the soil at the surface by entrapping the heat in the loose blanket of surface soil, which is a poorer conductor of heat downward than is the unloosened soil. The loosened seed bed prepared for spring seeding is therefore warmed and the germination of the seed hastened.

**75. Life in the soil.** Few people realize that the soil teems with living organisms. They are microscopic in size, but they are of great importance to soil fertility. The soil is an excellent

<sup>1</sup> A much greater number of heat units are required to raise the temperature of a pound of water one degree than are required to raise the temperature of an equal weight of soil one degree.

medium for the growth of bacteria and fungi, particularly when it contains considerable quantities of organic matter. The bacteria and the fungi existing in all soils are necessary to fertility. To be sure, there are forms of bacteria present which under certain conditions may work against the farmer's interests by undoing what helpful bacteria have done, but in soils which are well drained and properly cultivated the action of these injurious forms is unimportant.

The functions which these organisms perform are mainly in connection with the decay of organic matter. The supplying of plants with nitrogen in a form adapted to their needs is almost entirely due to the activity of these lower organisms. They also perform a valuable service in making available other necessary plant foods, such as phosphorus and potassium. Their effect in bringing about a loose, friable, or crumbly condition of the soil (largely through their action upon organic matter) is of no small importance.

The beneficial organisms are greatly stimulated in their development by thorough soil aëration and warmth. Since drainage removes standing water, admits air, and warms the soil, it is one of the most important means of influencing the development of beneficial organisms. A favorable degree of moisture in the soil is necessary for the work of these organisms just as it is for agricultural plants. Tillage, therefore, exerts an important influence upon the work of these organisms because it aërates and warms the soil, conserves moisture, and has a beneficial effect in other ways. The addition of organic matter and of lime likewise stimulates the development and action of the beneficial organisms. It is a part of the modern farmer's education to understand the handling of soils so as to favor the development of these organisms; also to maintain the proper degree of moisture and the most suitable temperature and texture of the soil for the highest development of the crops he seeks to grow. Soils which are cold may be made warmer, those which are wet may be made dry, and those which are "dead" may be made "alive."



## QUESTIONS AND PROBLEMS

1. What are the different senses in which the terms *heavy soil* and *light soil* are used?
2. What are the kinds of soils most commonly found in your locality? What crops are best adapted to each of these kinds of soil?
3. What procedure should be followed to bring a hard, cold soil into good tilth?
4. Why will farm crops not grow in saturated soil? In periods of wet weather corn leaves sometimes turn yellow; what is the explanation of this fact?
5. What is the water table of a soil?
6. Why will a fine soil retain more film water than a coarse soil? Why is a sandy soil in regions of limited rainfall classed as a wet soil?
7. What is the relation between frequent surface cultivation and conservation of soil moisture? and rise of capillary water? and evaporation from the surface?
8. Name the factors which determine the soil's temperature, and explain what you understand to be the influence of each of these factors. How may the farmer use this knowledge?
9. In what ways may the farmer encourage the development of helpful soil organisms?
10. One farmer plowed his field of clay soil immediately after a long period of rainy weather; another prepared a clay field for fall wheat, plowing it near the close of a summer's drought. Give reasons for or against these two practices.

## EXERCISES

1. **Microscopic study of soil particles.** Place on a glass plate a mass of soil the size of a pinhead; add two drops of water and rub with a glass rod until the fine soil pellets are broken down; place a small amount of the muddy water on a slide and examine under a high-power microscope. Notice particles of different minerals as shown by differences in color. Notice also masses of organic matter.
2. **Mechanical sorting of soils.**<sup>1</sup> Select several types of soil, including gravelly soil, sandy loam, peaty loam, and clay. Weigh out the same quantity of each (10 or 15 grams). Using glass tubes of the

<sup>1</sup> Centrifugal Method of Mechanical Soil Analysis, *Bulletin 24*, Bureau of Soils, United States Department of Agriculture.

same diameter and length, all stoppered at one end and each containing the same amount of water (200 to 300 centimeters in height), place one sample of soil in each tube. Shake well, stand in upright position, and observe at intervals, to see the way in which the soil settles in each case. Which soil settles first? Explain.

### 3. Percolation of water through soils of different textures.

**MATERIAL:** Three brass, glass, or galvanized-iron tubes from  $1\frac{1}{2}$  to 2 inches in diameter and from 8 to 10 inches long (straight lamp chimneys may be used); a rack or support to hold the tubes in place; 3 small beakers or cups; a graduated cylinder.

Tie a piece of cloth over one end of each tube and fill the tubes level full with the finely sifted soils that are to be tested. Use sand in one tube, loam in a second, and clay or clay loam in a third. Compact all to the same degree by allowing each to drop three times on the table from a height of one inch. Place the tubes in the support, with the beakers beneath, and pour a known amount of water in at the top, beginning with the tube containing the clay. Note the time required for the water to begin dripping. Then pour the same amount of water into each of the other tubes, and note the amount of water that passes through in the length of time allowed the clay tube. Calculate the relative rates of water percolation through these soils.

### 4. Effect of texture on capillary rise of water in soil.

**MATERIAL:** Five glass tubes from  $\frac{3}{4}$  to  $1\frac{1}{2}$  inches inside diameter and 2 feet long; a pan for water; a support for the tubes.

Tie a cloth over one end of each tube. Fill one with finely sifted and pulverized clay or clay-loam soil, another with finely sifted sandy-loam soil, and a third with sand. Jar each gently and in the same manner in order to settle the soil equally. Pour four inches of finely sifted sandy loam into the fourth tube, and insert enough finely cut straw to fill it for two inches, and pack the straw with a stick. Fill the tube with the fine sandy loam. In the fifth tube put clods instead of straw to serve as a barrier to the rise of the capillary water, but do not compact with the stick. Support each tube upright with the cloth-covered end in a pan of water and observe the height to which the water has risen in each soil at the following intervals: five, ten, thirty, and sixty minutes; two, three, twenty-four, forty-eight, seventy-two, and ninety-six hours. Plot curves of each to show results. Explain results.

### 5. Determination of water in the soil.

**MATERIAL:** Soil-auger  $1\frac{1}{2}$  inches in diameter; pint Mason fruit jars; a small piece of oilcloth; a balance sensitive to 0.1 gram; pie pans.

Carefully remove a core of soil twelve inches deep with the soil-auger, and transfer it to a piece of oilcloth, and then quickly to a pint Mason jar, screwing on the top promptly to prevent the loss of moisture. Insert the auger in the same hole and remove a core of the next twelve inches of soil, placing it in another Mason jar in the same manner.

Take both jars to the laboratory and transfer the soil of each to a weighed pie pan. Weigh moist soil and pan. Use a pair of scales for this purpose sensitive to 0.1 gram. Dry in the air, preferably in a warm place, such as over a radiator or near a stove, for several days, until the soil ceases to lose weight.

Calculate the per cent of water lost from the soil on the basis of air-dried soil.

Assuming that an acre-foot of soil weighs 4,000,000 pounds, calculate the number of tons of water in the surface foot and second foot in each case.

### REFERENCES

- BURKETT, C. W. Soils, chaps. ii, iv, xvii, xviii, and xxi. Orange Judd Company.
- FLETCHER, S. W. Soils, chaps. ii, iv-ix. Doubleday, Page & Company.
- HOPKINS, C. G. Soil Fertility and Permanent Agriculture, chaps. v-vi. Ginn and Company.
- HUNT, THOS. F. How to choose a Farm, chap. iv. The Macmillan Company.
- KING, F. H. Irrigation and Drainage, chaps. ii-iii. The Macmillan Company.
- KING, F. H. The Soil, chaps. v-xi. The Macmillan Company.
- LYON, T. L., and FIPPIN, E. O. Soils, pp. 133-210. The Macmillan Company.
- VIVIAN, A. First Principles of Soil Fertility, chaps. vi-vii. Orange Judd Company.
- Management of Soil to conserve Moisture, *Farmers' Bulletin 266*, United States Department of Agriculture.



## CHAPTER VII

### PLANT FOOD IN THE SOIL

There are four things that render land barren : the want of juices necessary for the nourishment of plants ; the having bad juices that tend to hurt and destroy plants ; the being so solid as to hinder the tender roots from extending themselves in search of their food ; and the being so porous and spongy as to be easily hurt by rain, heat, or cold. — VERGIL

**76. Three important elements of plant food.** The three elements of plant food which must be given most attention by the farmer are nitrogen, phosphorus, and potassium. These are important because they are most likely to be lacking in available form in a soil which has been cropped for some time, and because plants use them in somewhat larger quantities than they use the other soil elements except calcium. These are, therefore, the three elements which are commonly used in commercial fertilizers, and the ones most commonly mentioned in discussions of soil fertility. It is to these elements that the farmer must give most careful attention in maintaining soil fertility.

**77. Available and unavailable plant food.** Plants take their food from the soil, dissolved in the soil water. As the roots penetrate the soil and take in water they also take in plant food in solution.

Plant food-material which will dissolve in water and may be taken into the plant is known as available plant food, and the food that is insoluble or in solutions which cannot be taken up is known as unavailable. As most of the plant food in the soil

is in an insoluble form, it is necessary that this food be gradually made soluble if the plants are to secure enough for proper growth. There are various processes of making these materials soluble in the soil, some of which are under the control of the farmer. It is his business to handle the soil so as to bring enough of these plant food-materials into solution to supply crop needs.

**78. The amount of food used by plants.** The following table shows the amount of nitrogen, phosphorus, and potassium removed from an acre of land by good yields of crops :

CROP	NITROGEN	PHOSPHORUS <sup>1</sup>	POTASSIUM <sup>1</sup>
	<i>Pounds</i>	<i>Pounds</i>	<i>Pounds</i>
Corn, grain, 75 bushels . . . . .	75	13.75	14
stover, <sup>2</sup> 2.25 tons . . . . .	36	4.5	39
Total crop	111	18.25	53
Oats, grain, 60 bushels . . . . .	36 *	6	7
straw, 1.6 tons . . . . .	19	2.5	32
Total crop	55	8.5	39
Wheat, grain, 30 bushels . . . . .	35	4.5	8
* straw, 1.5 tons . . . . .	14	3	25
Total crop	49	7.5	33
Timothy, 1.5 tons . . . . .	36	4.5	35
Clover, 2 tons . . . . .	80	10	60
Cowpea hay, 2 tons . . . . .	93	9	63
Alfalfa, 6 tons . . . . .	300	27	144

These materials are required in approximately these proportions whatever the yield. If the soil is in such condition that only two thirds of the phosphorus, for instance, is available for a seventy-five-bushel corn crop, approximately two thirds of this

<sup>1</sup> The composition of fertilizers is usually expressed in per cent of phosphorus pentoxide ( $P_2O_5$ ) (a compound of phosphorus, incorrectly called phosphoric acid), and in per cent of so-called potash ( $K_2O$ ) (a compound of potassium). Neither of these compounds actually exist as such in fertilizers. They are simply means of expressing the quantities of phosphorus and potassium present. It is much simpler to speak of these plant foods as phosphorus and potassium, and there is an increasing tendency to use these simpler terms.

<sup>2</sup> The corn plant without the ear.

crop is all that will be produced. If there is sufficient phosphorus available for only half of this crop, only half the crop can be secured. The same rule will hold for the other elements. In other words, plants must have a balanced food supply, just as animals must have a balanced ration if they are to make a satisfactory growth. The table shows that crops like clover, alfalfa, and cowpeas require large quantities of nitrogen, though part of their nitrogen may through the medium of bacteria be taken directly from the air which is in the soil.

**79. The amount of plant food in soils.** The total amount of plant-food elements is large in some soils and comparatively small in others. The amount of phosphorus is usually less than that of either nitrogen or potassium, but phosphorus is used by crops in smaller quantities than is either of the other plant foods. Soils containing considerable clay contain much potassium, while sandy soils contain little. Very fertile soils contain in the top foot—the area from which the bulk of plant food is taken—enough nitrogen to produce about 80 corn crops of 75 bushels each, enough phosphorus to produce about 200 such crops, and enough potassium to produce 1000 such crops. This is assuming that both corn and stover are removed from the land and that nothing in the way of fertilizers is returned.

It cannot be assumed, however, that all of the plant food in a soil can ever be removed by crops, because the yields would become so low as to be unprofitable long before the plant food was entirely exhausted. On the other hand, it must be borne in mind that plant roots penetrate deeper than one foot and that the undersoil also contains large quantities of plant food, especially of phosphorus and potassium. In soils whose topography is such that the surface is gradually being washed away, new soil layers are slowly brought within the root zone. Often, especially in clay soils, this is sufficient to maintain the potassium supply, because of the large amount of potassium contained in the subsoil, but it will not keep up the phosphorus supply. It will be necessary to add phosphorus to our soils if they are to be kept productive.

**80. How much plant food is available in a season?** The production of 50 bushels of corn, which is double the average acre-yield in the United States, requires approximately 74 pounds of nitrogen, 11 pounds of phosphorus, and 35 pounds of potassium. It is estimated that about 2 per cent of the nitrogen and 1 per cent of the phosphorus and one fourth of 1 per cent of the potassium<sup>1</sup> in the soil may be available in a season for the use of crops. Therefore to produce 50 bushels of corn at least 3700 pounds of nitrogen, 1100 pounds of phosphorus, and 14,000 pounds of potassium must be within the reach of the plant roots.

Our best soils originally contained from 6000 to 8000 pounds of nitrogen, from 2000 to 3000 pounds of phosphorus, and from 30,000 to 45,000 pounds of potassium to the acre in the first twelve inches, but continuous cultivation, heavy cropping, surface washing, and leaching have reduced the store of plant food in most soils much below these amounts. Reasonably productive soils after having been in cultivation a generation or more contain as little as 3500 pounds of nitrogen, 1200 pounds of phosphorus, and 30,000 pounds of potassium. It is evident that if most soils are to produce heavy yields, either the food they contain must be made available more rapidly than it is in the average soil or the crops must be helped with a manure.

**81. How phosphorus and potassium are made available to plants.** Phosphorus and potassium are mineral elements derived from the mineral part of the soil. They are made available to plants partly through the action of the weather upon the soil and partly also through the effects of decomposing organic matter. Among the products set free in decomposing organic matter are nitric acid and carbonic acid, as well as other and more complex organic acids. These acids, particularly the carbonic acid, are taken up by the soil water and exert a much greater solvent action upon the undissolved soil compounds than does pure water, thus greatly increasing the solution of the soil minerals. Moreover, the phosphorus and potassium stored in the organic matter are

<sup>1</sup> Hopkins, Soil Fertility and Permanent Agriculture, p. 107.

set free through decay. It is therefore largely through the decay of organic matter in the soil that the phosphorus and potassium are made available to plants.

**82. How nitrogen is made available.** The supply of nitrogen is found largely in the organic matter of the soil. The nitrogen of organic matter cannot be used by plants until the organic matter undergoes decay. This decay is brought about by soil organisms — mainly by bacteria. In the decay of organic matter, one of the first compounds formed is ammonia, the odor of which is noticed where stable manure is decaying. This combines with carbonic acid to form ammonium carbonate. The bacteria which set the ammonia free are called *ammonifying* bacteria, and the process is known as *ammonification*. As soon as this group of bacteria has acted upon organic matter and ammonium carbonate is formed, other bacteria, known as *nitrifying* bacteria, act upon this ammonium carbonate. One group of these nitrifying bacteria produces nitrous acid, then a second group transforms the nitrous acid into nitric acid. Both the soil and the manure contain substances which combine with the nitric acid to form nitrates, such as calcium nitrate or sodium nitrate. This process by which the ammonium carbonate is transformed into nitrates is called *nitrification*. It is in the form of nitrates, which compounds are soluble in water, that plants take up most of their nitrogen.

**83. Conditions that favor nitrification.** The decay of organic matter and the transformation of nitrogen from the complex organic compounds to soluble nitrates are dependent upon various conditions. First, a reasonable amount of heat is necessary, since these processes do not go on rapidly in cold soil. Second, oxygen is necessary. This is supplied by the air within the soil. In soils which are full of water, so that the air is excluded, there is little or no decay of organic matter. In fact, under such conditions a group of bacteria known as *denitrifying* bacteria may break down the nitrates already in the soil and render the nitrogen unavailable to plants. This is just the opposite process from the one the farmer desires. Third,



a reasonable amount of moisture is necessary, since in very dry soils these processes are retarded. Fourth, basic substances, such as calcium and sodium, are necessary, with which nitric acid may combine to form nitrates.

A soil which is moist but not too wet, which is well aerated, and which is supplied with lime carbonate is in the ideal condition for the processes of ammonification and nitrification to take place. Drainage and thorough tillage both help to bring about such a condition. Obviously, it is necessary to keep within the soil a sufficient amount of organic matter, upon which bacteria may act.

**84. How legumes add nitrogen to the soil.** The class of plants known as legumes performs a very remarkable and interesting work in supplying nitrogen to the soil. Among the legumes are such plants as clovers, peas, beans, and alfalfa. It has long been known that the growing of these



FIG. 34. A soy-bean, cowpea, or clover catch crop helps the succeeding corn crop

plants has a decidedly beneficial effect on the soil. Nearly everyone who has lived in the country has heard men speak of clover as a "fertilizer." It was not until the latter part of the last century, however, that the cause of the beneficial action of legumes was discovered (Figs. 34 and 35). It was found to be due to their ability to take a part or all of their nitrogen from the soil air. It was also discovered that this property was in some way connected with the nodules, or tubercles, upon the roots of these plants. Careful examination showed these nodules to be literally filled with bacteria. It was finally demonstrated

that these bacteria had the power to penetrate the root, causing the nodules to form, and then to take up free nitrogen gas, which comprises four fifths of the volume of the air, and combine it with other elements in a form which the plant could use. It is therefore possible, through legume crops, to maintain and even to increase the quantity of nitrogen in the soil.

**85. Other free-nitrogen-gathering bacteria.** If a soil on which no legumes are allowed to grow remains uncropped for a few years, and if the amount of nitrogen in it is carefully determined



FIG. 35. Red clover increases the available nitrogen of the soil

at the beginning and the end of this time, the nitrogen supply of the soil will be found to have increased slightly. This increase is mainly due to the action of certain bacteria which have the property of fixing free nitrogen from the air, independently of legumes. Such bacteria are found in most soils, but under ordinary conditions the amount of nitrogen supplied to the soil by this means is not large.

**86. Inoculation for legumes.** Not all soils are supplied with the bacteria which cause the nodules on the roots of legumes. This is particularly true where legumes are introduced which have never been grown on the soil before. However, if a new

legume is repeatedly grown on the land, the bacteria may eventually cause the nodules to form on its roots. It has been found that the type of bacteria which grows well on clover roots, for instance, does not grow well on other legume roots. In other words, different legumes have different types of these bacteria especially adapted to their roots. Where a new legume is introduced, it is usually necessary to supply the bacteria suited to it, if the crop is to succeed. Supplying the proper bacteria is known as inoculation, and usually it is accomplished by working into the soil three or four hundred pounds per acre of soil taken from land where the legume in question has been grown. Recently, there has come into use a method of inoculation of the soil with prepared cultures of the desired bacteria. These are proving fairly satisfactory. In most parts of the United States soils rarely need inoculation for clover, but for other legumes, especially if they have not been grown before, inoculation is often necessary for a satisfactory crop.

**87. How a chemical analysis of the soil helps.** A chemical analysis shows how much of each of the elements of plant food a soil contains. It is important that the farmer have this knowledge, in order that he may give special attention to maintaining or increasing the amounts of those elements that are present in the smallest quantities. But a chemical analysis fails to show how much of each of these elements is immediately available for the crops. It is not possible, therefore, to determine by means of a chemical analysis the crop to which a particular soil is adapted, or what fertilizers will give the best result. A field test is the only way in which these questions can be accurately answered.

**88. What the plant food in our soil is worth.** If asked to name the most valuable minerals of the United States, most persons would promptly suggest gold, silver, iron, lead, zinc, and copper. Yet the American farmer mines more wealth from the soil in a single year than has been taken from the gold mines of the United States in all the years since Columbus discovered America. It is literally true that our most important mineral

deposits are the elements of plant food contained in our soils. The soil is the only mine known which under proper management will not run out. But too many farmers are yet "mining" their soil by taking everything out and putting nothing back. A city built near a mine is abandoned when the mine ceases to yield its mineral. A nation built upon agriculture will perish when the soil can no longer yield its harvest.

### QUESTIONS AND PROBLEMS

1. What are the three elements of plant food in which the farmer is most interested? Why are these of such importance?
2. How do you explain the fact that soils are sometimes said to contain large quantities of unavailable plant food?
3. How may the farmer increase the amount of available plant food in the soil?
4. Of the three elements, nitrogen, phosphorus, and potassium, which is likely to be exhausted first? How may this element be replenished?
5. Describe the processes which vegetable matter must undergo before it is of value to the land and crops.
6. What are the four essential conditions in the soil for successful ammonification and nitrification?
7. As organic matter undergoes these processes, how does it help the soil?
8. Secure the records from some agricultural experiment station where they have grown the same kind of crop for many years upon the same land, and see what results followed.
9. Why is a subsoil usually infertile for farm crops?

### EXERCISES

#### 1. The effect of organic matter upon soil fertility.

MATERIAL: Two one-gallon pots.

Fill two one-gallon flower pots with a finely sifted clay subsoil until, after being settled well by jarring, the subsoil comes to within an inch and a half of the top. Empty each pot separately upon a piece of oilcloth or paper.

Secure a quantity of leaf mold and rub through a one-fourth inch sieve. To one batch of subsoil add about half its bulk of this

fine leaf mold and mix thoroughly. Spread out each batch of soil and add water carefully until the soil is moist enough to germinate seeds, but not too wet. Replace the soil in the pots and settle by jolting. Plant five kernels of corn in each pot, and weigh. Add enough water every other day to replace that lost by evaporation, as shown by repeated weighings. Keep in a warm, sunny window and for three weeks continue to observe the growth of corn in each pot. Note and explain results.

2. Plant two sets of corn grains in pots of sand. Water one each day with water which has been allowed to run slowly through some decaying manure. Water the other pot with the same amount of pure water. Note and explain results.

3. Carefully dig up a sweet-clover, red-clover, or alfalfa plant and locate on the roots the nodules in which the bacteria live. Compare the nodules on the different kinds of legumes in your locality.

#### REFERENCES

- BURKETT, C. W. Soils, chaps. vi-ix, xv, and xvi. Orange Judd Company.  
HOPKINS, C. G. Soil Fertility and Permanent Agriculture, chaps. ii, iii, and vii. Ginn and Company.  
KING, F. H. The Soil, pp. 71-153. The Macmillan Company.  
LIPMAN, J. G. Bacteria in Relation to Country Life, chaps. xxi-xxiii. The Macmillan Company.  
LYON, T. L., and FIPPIN, E. O. Soils, pp. 267-291. The Macmillan Company.  
VIVIAN, A. First Principles of Soil Fertility, chaps. ii and iv. Orange Judd Company.

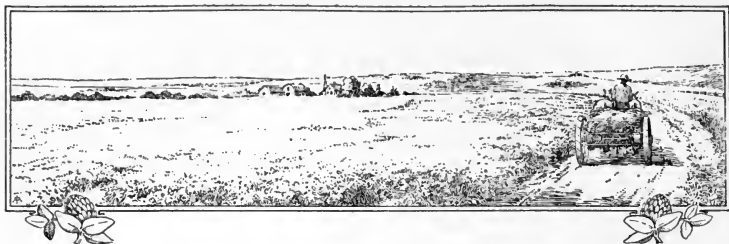

## CHAPTER VIII

### MAINTAINING SOIL FERTILITY

Thus, when a field is poor, it is a custom, instead of manuring it, to plow in a crop of lupines before the pods appear — sometimes a crop of beans before the pods are so far advanced as to render the fruit fit for being gathered. —  
VARRO

**89. How the soil is wasted.** Soil productivity may be decreased through tillage, by the removal of plant food through cropping or by leaching or by washing away of the surface soil. Under the systems of agriculture common to the greater part of the country, all three of these means of wasting the soil are important. It is impossible entirely to exhaust the plant food of a soil under any system of agriculture, since profitable culture ceases long before a complete state of exhaustion is reached.

**90. Tillage wastes the soil.** Soils covered with natural vegetation slowly increase in organic matter and in nitrogen. Therefore soils in their virgin state contain the maximum quantity of organic matter, and this in turn sets free abundant supplies of nitrates and makes the other plant foods available. This is why new soils are usually very productive. In the rapid decay of organic matter, however, large quantities of nitrogen are lost, partly through the leaching<sup>1</sup> of nitrates (especially from porous soils), but principally through the escape of nitrogen into the

<sup>1</sup> As water passes down through the soil, it carries with it soluble plant food, a part of which may be permanently lodged in the subsoil, and a part leached out in the drainage water.

air as free nitrogen. Experiments have shown that in the first two or three decades after new land is brought into cultivation, the loss of nitrogen from these two causes may be two or three times as large as the loss through the removal of the crops grown on the land.

**91. Organic matter and nitrogen.** The organic matter and the nitrogen of the soils of the corn belt have been decreased approximately one third and in many cases one half since they were first put into cultivation — mainly through intensive tillage



FIG. 36. How soils wash

The greatest waste of soil fertility is the waste of the soil itself. Heavy rain falling upon soils from which the vegetation has been removed wash away much of the best soil.  
(Photograph from Bureau of Soils, United States Department of Agriculture)

incident to the growing of corn. Indeed, the loss of organic matter is responsible for the decreased productivity of most so-called "worn" or depleted soils. This is probably because a soil which is low in organic matter is usually in poor physical condition; the bacterial activity in such a soil is lessened, and the soil loses its "life," as the farmer says.

**92. Removal of plant food in crops.** The loss of plant-food elements through the removal of the crops grown on the soil can be readily understood. If crops are continually removed and nothing is returned, the supply of *available* food is soon depleted, and finally the *total* amount of plant food in the soil

may be appreciably decreased. The Chinese people are farming lands that have been cultivated for four thousand years, and they are maintaining many of them in a high state of fertility ; but they have found it necessary to keep up the supply of organic matter, and to return to the land each year the equivalent of the plant food removed. It is only in the older sections of the United States that there is anything like a well-established system of



FIG. 37. Terrace farming prevents erosion

Where soil is not frozen during the winter and rains are frequent, the loss from erosion is great. In such regions erosion is often prevented by terracing. (Photograph from Bureau of Soils, United States Department of Agriculture)

returning to the soil the complete equivalent of the plant food removed. The majority of American farmers are depending largely upon the virgin fertility of the soil, and are pursuing methods of farming which are destructive of the store of plant food.

**93. Waste through surface washing.** There is no accurate way to estimate the loss of fertility through surface washing, or erosion ; but the loss is great (Fig. 36). The amount of erosion occurring when lands are covered by vegetation is small ; but



when lands are put into cultivation, the loss is great. According to King,<sup>1</sup> the Mississippi River carries annually toward the Gulf sufficient soil material to cover seventy-two sections of land with a deposit four feet deep. Whenever the subsoil is exposed by washing away the surface soil, the value of the land for crop production is greatly decreased. This is a common cause of decreased productiveness on rolling lands.

Some lands erode much more rapidly than others, even with the same topography. Coarse sandy soils and heavy clays are least subject to erosion, while loams and those soils containing

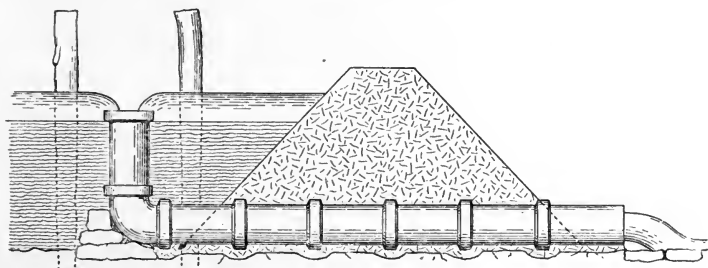

FIG. 38. Tile drainage reduces erosion

A dam of earth is built across the gully. The soil carried by the water is deposited, and the clear water is carried away by tile

much silt and fine sand are subject to the greatest erosion. In the Southern states, where the soil does not freeze during the winter, erosion is much greater than in the Northern states. In the South it is common to plow the land and to plant crops across, rather than up and down, the slopes. This is known as contour farming. Sometimes, where the slopes are quite steep, the land is thrown up into terraces (Fig. 37). As soon as a gully, or ditch, begins to form, it should be made to fill again by throwing in straw or brush, or by constructing a ditch, to check the flow of water and to catch the soil that is being carried away (Fig. 38). Sowing grasses in ditches is another common method of preventing erosion.

<sup>1</sup> The Soil, p. 48.

Keeping the land covered with a crop during the fall, winter, and spring months is a very practical method of checking erosion, as well as of preventing the loss of plant food from leaching. Crimson clover, rye, winter wheat, winter oats, and barley are crops used for this purpose.

**94. Crop rotation.** A small grain crop, such as oats or wheat, or a grass crop, such as timothy or blue grass, is less exhaustive to the soil than a cultivated crop, like corn. Consequently, cultivated crops should be alternated with small grain and grass crops. It is also important to include in the rotation a legume crop, such as clover, alfalfa, cowpeas, or field peas, because of the ability of legumes to fix nitrogen from the air. This policy may not always be feasible; but it suggests the first great principle of maintaining fertility, that of crop rotation.

The following is a table showing the effect of different crop rotations upon soil fertility, as measured by the soil's ability to produce corn:

#### EXPERIMENTS IN CROP ROTATION

I. <sup>1</sup> ROTATION	YIELD OF CORN AT END OF PERIOD
Corn, continuously 28 years . . . . .	22 bushels per acre
Corn, oats, 28 years . . . . .	36 bushels per acre
Corn, oats, clover, 28 years . . . . .	59 bushels per acre
Pasture, 18 years; corn, oats, clover, 10 years . . . . .	75 bushels per acre
II. <sup>2</sup>	
Corn, continuously 17 years . . . . .	11.8 bushels per acre
Corn, wheat, clover, 17 years . . . . .	50.7 bushels per acre
Corn, oats, wheat, clover, and timothy, 17 years . . . . .	54.7 bushels per acre
Corn, oats, wheat, clover, and timothy— manured, 17 years . . . . .	77.8 bushels per acre

It should be borne in mind that these results were obtained with all crops, even the cornstalks, removed from the land.

<sup>1</sup> Illinois Experiment Station, *Circular 95*.

<sup>2</sup> Missouri Experiment Station. Results not yet published.

**95. Essentials of profitable crop rotation.** A profitable crop rotation for a general farm should include a "cleansing crop," that is, a cultivated crop to rid the soil of weeds; a so-called "resting crop," such as a legume or grass crop, which tends to increase the supply of organic matter and nitrogen; and a small grain crop, such as wheat, oats, barley, or rye, which is usually a "money crop." Naturally, the rotation adopted will depend upon many conditions. In the corn belt and in many sections of the East where the practice of rotation is best established, such rotations as corn, oats, and clover, or corn, oats, wheat, and clover, or potatoes, wheat, and clover are common. In the Southern states it may be such rotations as cotton, oats, and cowpeas, or cotton, corn, oats, and cowpeas. In order to carry out such a rotation it is necessary to have as many fields as there are years in the rotation, each crop being represented on one of the fields each year, and all fields following the rotation regularly. Where a crop fails, it is usually wise to plant in the same season a crop having an effect upon the soil which is similar to that of the failing crop. Thus, if clover fails, another legume adapted to the region should be substituted if possible.

**96. The importance of legumes in maintaining fertility.** It is possible to supply nitrogen to the land through legumes at a cost of from 3 to 5 cents a pound, whereas in a commercial fertilizer it costs from 15 to 20 cents a pound. Therefore every successful rotation on the average farm must contain a legume crop (Fig. 39) if the nitrogen supply is to be maintained cheaply. The time may come when a cheap commercial source of nitrogen as a fertilizer will largely take the place of legumes in supplying this element; but such a cheap substitute is not now available. Moreover, organic matter must be maintained, and the legume crops furnish one of the most ready means of supplying this. In case a man buys and uses much feed and applies the resulting manure to the land, or in the comparatively few cases where barnyard manure can be obtained from the city in large quantities, the necessity for legumes is lessened.

**97. The use of green manure.** A green-manure crop is one which is grown and turned under for the purpose of enriching the soil in organic matter. The most profitable crops for this purpose are usually the legumes, because of the nitrogen they secure from the air. In the case of clover about two thirds of the total nitrogen of the plant is in the tops, which are removed as hay if the crop is harvested, while one third is in the roots



FIG. 39. Cowpeas in rotation with grain crops help maintain soil fertility

Photograph from Missouri Experiment Station

and stubble. On average soils the clover plant gets about one third of the nitrogen from the soil and about two thirds from the air. Hence, where a clover crop is removed from the land for hay and only the stubble and roots are left as a fertilizer, the gain of nitrogen by the soil is small. If the crop is fed and the manure is carefully saved and applied to the soil, about 70 per cent of the nitrogen in the hay can be thus returned, and the soil will be made richer in nitrogen than before the clover was grown upon it. The greatest gain to the soil from

growing a legume comes from turning under the crop as a green manure. It is, however, not often profitable to plow under one of the regular legume crops as a manure, for the reason that legumes are too valuable as food for live stock.

We have at last learned that there is no soil of inexhaustive fertility; that all soils, if carelessly or unintelligently managed, sooner or later need to be rested and repaired. When a soil's productiveness has been materially decreased, it is no easy matter to build up that soil again and make a living from it at the same time. Therefore it is much better to keep lands productive than to allow them to become depleted and then attempt to build them up. It is the duty of the younger generation of farmers so to inform themselves regarding methods of soil management that they will be able to maintain the productiveness of their land.

#### QUESTIONS AND PROBLEMS

1. Why is an old cultivated field less favorable to plant growth than a new field?
2. Suggest methods by which a farmer may prevent his land from becoming an unfavorable place for plant growth.
3. If the Mississippi River carries a deposit each year that would cover 72 sections of land to a depth of 4 feet, how many farms of 160 acres each would this cover with a surface soil 8 inches deep?
4. The average farm is supporting three families — one on the land and two in town. Allowing five people to each family, and supposing each farm to include 160 acres, how many people could be supported by the land washed away each year in the Mississippi basin?
5. How may this great waste of erosion be retarded?
6. It is sometimes stated that one third of the fertility of the soil in the corn belt has been exhausted in two generations. If this is true, what are some of the reasons for a change in farming methods?
7. What are the best reasons for crop rotation?
8. Based upon the experiments made by the Illinois and Missouri experiment stations in crop rotation in mind, explain why the different yields of corn were secured.
9. In what ways do green manures affect soils? What crops make the most valuable green manure?

## EXERCISES

1. Using one of the rotations suggested in the text, draw up a plan for a farm, showing (1) the number of fields, (2) what each field will have growing on it for each of ten years, (3) the total acreage of each crop each year, assuming each field to contain thirty acres.

2. Would such a plan be practicable on a farm used for diversified farming? Would there be enough of each crop each year to make economical use of machinery and other equipment? Would it produce the proper proportions of each crop yearly to furnish feed for a live-stock farm, or would there be an excess of certain crops in some years? Write out a list of the principles to be observed in planning a crop rotation.

3. If your local region contains an illustration of badly washed soils, visit the place, and plan a way of stopping the erosion. If the owner will allow you to try the experiment, carry out your plan, and watch the results.

4. Try to get a farmer who pastures his clover until plowing time to leave one acre unpastured, plowing under all the clover on this acre. Watch the effect on the next crop.

## REFERENCES

- AGEE, ALVA. Crops and Method for Soil Improvement, chap. xv. The Macmillan Company.
- FLETCHER, S. W. Soil, chaps. xi-xii. Doubleday, Page & Company.
- HOPKINS, C. G. Soil Fertility and Permanent Agriculture, chaps. xii-xv. Ginn and Company.
- LIPMAN, J. G. Bacteria in Relation to Country Life, chap. xxiv. The Macmillan Company.
- SNYDER, HARRY. Soils and Fertilizers, pp. 255-284. Chemical Publishing Company.
- THORNE, C. E. Farm Manures, chap. xii.
- VIVIAN, A. First Principles of Soil Fertility, chaps. iii, ix, and x. Orange Judd Company.
- VOORHEES, E. B. Fertilizers, chap. i. The Macmillan Company.
- Renovation of Worn-out Soil, *Farmers' Bulletin 245*, United States Department of Agriculture.
- Leguminous Crops for Green Manure, *Farmers' Bulletin 278*, United States Department of Agriculture.
- Conservation of Soil Resources, *Farmers' Bulletin 342*, United States Department of Agriculture.

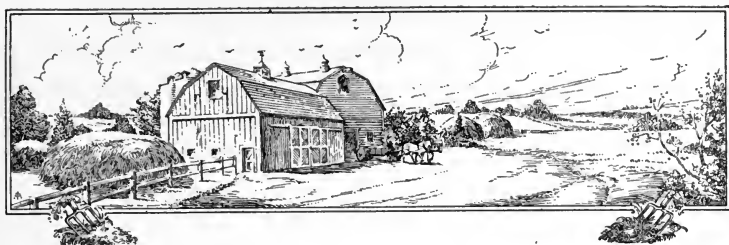

## CHAPTER IX

### BARNYARD MANURE

The excrement of fowls is the best and of these pigeon excrement is the most excellent, because it is warmest, and ferments the earth. All of this kind should be strewed upon the field, and not laid in heaps like the manure from cattle. Horse manure is the worst kind; but it is so only when applied to corn fields; for it is the best for meadows, as is that of all work cattle that are fed with barley, because it produces plenty of grass. — CASSIUS

**98. The importance of barnyard manure.** The farmers before the time of Christ considered the application of manure one of the principal operations in agriculture and placed it next to plowing. King Augeas explained the use of manure to the Greek farmers, and Homer mentions a king who strewed manure with his own hands. Italy immortalized the man who taught the Roman farmer how to use manure. Even in that day they had progressed so far as to preserve their manure in pits with concrete bottoms to prevent the waste of its valuable ingredients. To-day, among the peasants and small farmers of some European countries, a man's prosperity is judged by the amount of manure he uses on his farm, but it is only in the parts of the United States that have been farmed longest that the value of manure is appreciated by the American farmer.

It is estimated<sup>1</sup> that the farm manure produced in the United States in a single year is worth more than two billion dollars, or more than the entire corn or wheat crop. This manure contains

<sup>1</sup> *Farmers' Bulletin 21*, United States Department of Agriculture.

tenfold more plant food than all the commercial fertilizers used in a year. Little attention is given to the care of this manure, and in the country as a whole nearly half of it is wasted. Next to the waste of the soil itself, this is probably the greatest waste on American farms.

**99. What is manure?** Any material which contains considerable quantities of more or less available nitrogen, phosphorus, or potassium, and which is added to the soil for the purpose of increasing crop yields, is called a manure or fertilizer. Such materials usually are not applied in sufficient quantities to supply the entire needs of the crop, but enough is applied to supplement the available plant food already in the soil. Farm manure, commonly called barnyard manure, is derived from the farm itself, as the manure from farm animals or the refuse from crops. Commercial fertilizers are those sold on the general market and consist of concentrated and soluble forms of the three elements of plant food — nitrogen, phosphorus, and potassium.

**100. Value of barnyard manure.** The value of barnyard manure is the plant food it contains, the organic matter which it supplies to the soil, and the beneficial action its presence exerts upon the soil organisms. The plant food in manure comes from that taken from the soil by the crops. When crops are fed to animals, approximately three fourths of the nitrogen, phosphorus, and potassium goes with the manure and may be returned to the land. These plant foods are then in a form to become quickly available through decay of the manure.

**101. Value of manure from different animals.** The value of manure when the feed remains the same depends upon the kind and age of the animals by which it is made. Growing animals take more nitrogen from their food for the production of muscle and more phosphorus for the production of bone than grown animals that are at work or that are merely fattening.

**102. Value of manure per one thousand pounds live weight of animals.** In the following table the values are based on the amount of the principal elements of plant food present in



average well-kept manure and bedding, estimating nitrogen to be worth 20 cents a pound; phosphorus, 12 cents a pound; and potassium, 6 cents a pound:

VALUE OF MANURE	EXCRE- MENT PER YEAR	EXCRE- MENT WITH BEDDING PER YEAR	VALUE PER YEAR	VALUE PER TON
	<i>Tons</i>	<i>Tons</i>		
Horse . . . . .	8.9	12.1	\$42.15	\$3.48
Cow . . . . .	13.5	14.6	39.00	2.67
Sheep . . . . .	6.2	9.6	46.05	4.79
Hog . . . . .	15.3	18.2	80.60	4.42
Fowls . . . . .	4.3	4.3	68.15	15.84

This means that the nitrogen, phosphorus, and potassium contained in the manure produced in a year by a thousand-pound horse would cost \$42.15 if bought in the form of a commercial fertilizer. The other facts presented are equally significant. No farmer could afford to pay such prices for manure with which to grow ordinary farm crops, but it is indisputably true that the manure produced from farm animals has a very high value and deserves much more care than it usually receives.

**103. Effect of feed on character of manure.** The kind of material fed to animals affects very strikingly the value of manure. Grains and other feeds containing much protein, such as cottonseed meal, linseed meal, tankage, clover hay, cowpea hay, and alfalfa hay produce a manure rich in nitrogen. On the other hand feeds containing little protein, such as corn, timothy hay, millet, corn stover, and straw produce a manure poor in nitrogen and of comparatively low value. A very important part of the profit from feeding a liberal amount of highly nitrogenous feeds is in the greater value of the manure produced. The use of nitrogenous feeds and the careful saving of the manure may be great factors in reducing fertilizer bills, and thus increasing the profits of farming.

**104. Losses in manure.** If manure is piled where it is unprotected from the weather, a large share of the fertilizing constituents will be leached out by the rain (Figs. 40, 41). The brown liquid often seen running from manure piles is carrying away its most valuable constituents. Exposure to the weather, in piles, causes decomposition of the organic matter and loss in weight. With the exception of manure to be used on garden



FIG. 40. A common method of wasting manure  
 Photograph from Cornell Experiment Station

or truck crops it is better to have decomposition take place after the manure has been applied to the soil.

A pile of horse manure weighing four thousand pounds was exposed to the weather from April 25 to September 22. The following table shows the losses which occurred in this experiment :

	APRIL 25	SEPTEMBER 22	LOSS PER CENT
Weight . . . . .	4000 pounds	1730.1 pounds	57
Nitrogen . . . . .	19.6 pounds	7.7 pounds	60
Phosphorus . . . . .	6.4 pounds	3.5 pounds	47
Potassium . . . . .	29.8 pounds	7.1 pounds	76
Value . . . . .	\$6.47	\$2.38	63

While these losses may be higher than would occur in mixed manures, it is evident that it is very easy for manure to lose one half its fertilizing value when exposed in piles around the barnyard.

**105. Fermentation of manure.** Manure piled in loose heaps ferments rapidly. This is particularly true of piles containing horse manure from which much ammonia escapes. Advantage



FIG. 41. Education makes the difference

The buildings shown here and in Fig. 40 are on the same farm. When this young man, a graduate of an agricultural college, came into possession of this farm he hauled to the fields 600 loads of accumulated manure from the barn and barnyard

is taken of this fact in making hot beds for forcing vegetables. When fermentation goes on rapidly, large quantities of ammonium carbonate escape into the air and the nitrogen is thus lost, instead of being transformed into nitrates for the use of plants. The presence of air stimulates bacterial growth, while the absence of air retards it. If manure is kept moist and well compacted, fermentation is held in check. The fact that cow manure is usually wet and compact explains its rather slow rate of fermentation in comparison with horse manure.

**106. Care of manure.** For general use manure is never better than when fresh; therefore the ideal method of handling it is to apply it to the fields without allowing it to stand. Unfortunately this is not always practicable. Since the introduction of the manure spreader (Fig. 42), however, this method is coming into much more general use. In some parts of the country the feeding of animals directly on the fields is a method which accomplishes the same end.

Where manure cannot be directly applied to the fields, care should be taken to store it properly.<sup>1</sup> The prime essentials in

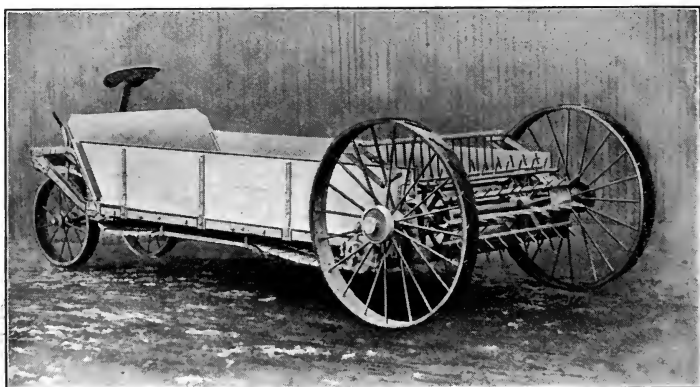

FIG. 42. A manure spreader soon pays for itself on a stock farm

storing manure are first, that it be kept either under cover or in a water-tight pit, to prevent the loss from leaching by the rain; and second, that it be kept compact and moist so that fermentation is retarded.

The use of a manure pit with a water-tight bottom, in which manure can be stored, is common in some regions. In this case the manure should be tramped in so as to exclude the air as completely as possible. If the manure contains plenty

<sup>1</sup> In densely populated regions, for hygienic reasons it may be desirable to treat manure with potassium or phosphate salts (which are unfavorable to the growth of disease-carrying organisms, such as the larvæ of flies) or to keep the manure in fly-tight containers, such as concrete manure boxes.

of straw or other coarse material, most of the rain will be absorbed. The water-tight bottom prevents loss by leaching. A pit with a tamped-clay bottom is fairly satisfactory, but one with a concrete bottom is better.

Sometimes, where much bedding is used, the manure may be allowed to accumulate in the stables, although this is not usually practicable in horse stables. Where cattle or sheep are fed, one of the most practical and satisfactory methods of handling manure is to feed the animals under a large shed, if the climate is not too severe, and allow the manure to accumulate during the winter. In such cases the animals keep the manure moist and well compacted, thus retarding rapid fermentation; and as the manure is sheltered from the rain, there is no loss from leaching. The bedding and waste of the feed are mixed with the manure, and the whole makes a manure of good quality. It is sometimes practicable to put the manure from the horse stables into the cattle sheds, where it is mixed with the cattle manure, and the whole is preserved together.

**107. Reënforcing barnyard manure with phosphates.** Average barnyard manure is somewhat lower in phosphorus than in nitrogen and potassium, due to the fact that considerable quantities of phosphorus are retained in the bones of the animals, especially if the animals are growing rapidly. Consequently it is often wise, particularly on soils deficient in phosphorus, to add phosphates to the manure before the manure is applied. An interesting experiment upon this question has been performed.<sup>1</sup> Two grades of manure were used, one (called stall manure) taken directly from the stable, the other (called yard manure) such as had accumulated in a heap in the open lot. Each of these two kinds of manure was divided into three lots, one lot of each kind receiving 40 pounds of rock phosphate<sup>2</sup> per ton, another 40 pounds of acid phosphate<sup>3</sup> per ton, and the

<sup>1</sup> Ohio Experiment Station, *Circular 13*, p. 645.

<sup>2</sup> A finely ground rock containing about  $12\frac{1}{2}$  per cent of phosphorus.

<sup>3</sup> Phosphate rock after it has been treated with sulphuric acid to make the phosphorus more readily available to growing plants.

third receiving no phosphate. These various lots of manure were then compared as to their effect upon the yield of corn, wheat, and clover grown in rotation through a series of several years, the manure being applied at the rate of 8 tons per acre on clover sod before plowing for corn. The following table shows the money return per ton of manure in an average round of the rotation :

MANURE AND TREATMENT	NET VALUE OF CROP INCREASE PER TON OF MANURE
Stall manure without phosphate . . . . .	\$3.33
Stall manure with rock phosphate . . . . .	4.53
Stall manure with acid phosphate . . . . .	4.88
Yard manure without phosphate . . . . .	2.55
Yard manure with rock phosphate . . . . .	3.63
Yard manure with acid phosphate . . . . .	4.17

This experiment not only shows a good money return from adding phosphate to the manure applied to a soil needing phosphorus but also shows that the stall manure which receives proper care is more valuable than the yard manure which is exposed to the weather.

As a result of such experiments as this, it is becoming a common practice in some parts of the country, particularly in the corn belt, to apply from 60 to 100 pounds of phosphate to each ton of manure before scattering it on the land. Phosphate may be applied from time to time as manure accumulates, or it may be added to the manure in the spreader (Fig. 42), plowing it under for corn or other cultivated crops.

**108. Application of manure.** Manure is usually applied before planting a cultivated crop, such as corn, and is plowed under, although frequently it is applied as a top-dressing to meadows or wheat. The rate of application depends upon many conditions, but 8 tons per acre once in four or five years may be termed a good application for plowing under and from 4 to 6 tons an acre for top-dressing. On truck farms applications of 15 tons or more are common. The time of plowing manure under depends mainly upon convenience and the crop to follow.

If the manure is coarse, it should be plowed under as long in advance of planting as possible, so that it may have ample time in which to decay and thus make available the plant food which it contains; but if it is well rotted, early plowing in is not so important. A manure spreader is recommended for every stock farm, as it saves labor and spreads the manure evenly, thus causing the manure to go farther and bring a larger return.

### QUESTIONS AND PROBLEMS

1. Using the data in this chapter as a basis, calculate the supposed value of the manure from the stock on some particular farm in your locality.
2. What are the prevailing methods of distributing manure on the farms in your locality?
3. What are the advantages of distributing manure by use of a spreader?
4. Would it be a good investment for a farmer to buy rock phosphate or acid phosphate to scatter with manure?
5. How many of the barnyards or feed-yards of the neighborhood are located on hillsides where the leachings from the manure and the manure itself are carried away by each rain?
6. Explain the loss in value by the exposure of manure to the weather.
7. How may manure be kept so as to retain its value?
8. What are the advantages of applying manure while it is fresh?
9. In case the feed is the same, which manure is more valuable, that which comes from young growing animals, or that from grown animals which are fattening?
10. How does the manure from animals fed on corn and timothy hay compare in value with that from similar animals fed on corn, cottonseed meal, and clover hay?
11. How does the manure from different kinds of farm animals compare (a) in amount produced, (b) in value per ton, and (c) in value per year?

### EXERCISES

1. There are in round numbers 6,000,000 farms in the United States. What is the value per farm of the manure produced each year? If half the manure produced is wasted, what is the annual loss per farm from this source?
2. Does half of the manure in your community go to waste?

3. Make a plan showing the location of the barnyard and feed-yard with a view to the conservation of manure and to the convenience of feeding.

4. How many farmers in the neighborhood use manure-spreaders, and how many spread the manure as it is produced? How many allow it to accumulate under the eaves of the barn?

#### REFERENCES

HOPKINS, C. G. Soil Fertility and Permanent Agriculture, chap. xxx. Ginn and Company.

ROBERTS, J. P. The Fertility of the Land, chap. viii. The Macmillan Company.

SNYDER, HARRY. Chemistry of Soils and Fertilizers, chap. v. Chemical Publishing Company.

THORNE, C. E. Farm Manures, chaps. iv-viii, and x. Orange Judd Company.

VAN SLYKE, L. L. Fertilizers and Crops, chaps. xvii-xviii. Orange Judd Company.

VIVIAN, A. First Principles of Soil Fertility, chaps. xi-xv, and xvi. Orange Judd Company.

WHEELER, H. J. Manures and Fertilizers, chaps. iii and v. The Macmillan Company.

Barnyard Manure, *Farmers' Bulletin 192*, United States Department of Agriculture.





## CHAPTER X

### COMMERCIAL FERTILIZERS<sup>1</sup>

There are some farms on which neither the manure of cattle nor of birds is to be got; however, even in such places, he is a slothful husbandman that has no manure. — COLUMELLA

**109. Why we need commercial fertilizers.** Under the best systems of farming only a part of the food taken from the soil by crops is returned in manure. There is a constant stream of soil fertility flowing from the farm to the city in breadstuffs, meats, and fruits that are sent there to feed the people. In the city the waste from these foodstuffs is a nuisance. On the land it is a blessing. For centuries the Chinese farmers have gathered this waste and applied it to the land. We have turned to other sources, such as the phosphate and potash mines and the by-products of manufacturing, for the plant food which the farm manures do not supply. These mined or manufactured fertilizers, such as nitrate of soda, acid phosphate, and bone meal, are called commercial fertilizers to distinguish them from natural fertilizers like barnyard manure or green manure.

**110. Extent to which commercial fertilizers are used.** The use of commercial fertilizers in the United States is rapidly increasing. In 1889 the farmers spent \$28,000,000 for fertilizers;<sup>2</sup> in 1899, \$55,000,000; in 1909, \$112,000,000. The

<sup>1</sup> In localities where commercial fertilizers are not used, it is suggested that this chapter be omitted or be considered briefly.

<sup>2</sup> United States census reports.

use of commercial fertilizers has been confined largely to the Eastern and Southern states, but as the land of the corn belt becomes more worn, increasing amounts of commercial fertilizer are being used.

**111. Nitrogenous fertilizers.** Fertilizing material containing nitrogen may be divided into two general classes, animal products and plant products. Among the common animal products are wastes from the slaughterhouses, such as dried blood and tankage. With these may be classed the guanos, made up of the excrement of sea fowls, gathered from islands of the west coast of Africa. The common materials derived from the plant world are cotton seed and cotton-seed meal, linseed meal, and castor pomace. Other products, as sodium nitrate and ammonium sulphate, are quite largely used.

**112. Nitrate of soda.** The most widely known nitrogenous fertilizer is nitrate of soda, which is found in the rainless region of Chile. As it comes on the market it contains about 16 per cent of nitrogen. It is entirely soluble in water and therefore is immediately available for plant use. It should be applied only where plants can make immediate use of it; otherwise it may leach out of the soil and be lost.

**113. Sulphate of ammonia.** The principal source of sulphate of ammonia is coal, it being a by-product of the manufacture of gas and coke. It contains about 20 per cent of nitrogen, and is entirely soluble in water. However, the nitrogen must be largely transformed to a nitrate by nitrifying bacteria before it can be used by plants.

**114. Dried blood.** One of the most important sources of animal nitrogen is dried blood. The nitrogen it contains must be transformed to a nitrate by bacteria before it is available to plants. Red blood contains from 13 to 14 per cent of nitrogen, and black blood from 6 to 12 per cent.

**115. Tankage.** This is a term applied to various miscellaneous waste materials of the slaughterhouses which are dried and ground. It contains from 4 to 12 per cent of nitrogen and from  $1\frac{1}{2}$  to 5 per cent of phosphorus.

**116. Low-grade nitrogenous fertilizers.** There are a number of materials containing either a low percentage of nitrogen or nitrogen in a form which becomes available very slowly when applied to the soil, as leather meal, wool and hair waste, horn and hoof meal. These are commonly used in making low-grade fertilizers, but their use as a source of plant food is not recommended.

**117. Nitrogen from the air.** Through large electric furnaces operated at low cost by water power, it is possible to combine the nitrogen of the air with other substances at sufficiently low cost to be used for fertilizing purposes. There are two such products on the market—calcium cyanamide and calcium nitrate. The former contains about 20 per cent of nitrogen, which must be transformed into a nitrate by soil bacteria before it is available. The latter contains about 12 per cent of nitrogen in a readily available form.

**118. Where nitrogenous fertilizers are used.** The use of nitrogenous fertilizers is confined largely to regions where heavy fertilization of the soil is practiced. In general, the more soluble forms should be applied at such times and in such quantities as to be of immediate use to the plants, as otherwise they will leach from the soil and be lost. On the other hand, those forms coming from animal and plant products are more slowly available, since the nitrogen must be acted upon by bacteria in the soils; hence these forms may be used with less danger of the nitrogen being lost by leaching.

**119. Phosphatic fertilizers.** Phosphatic fertilizers are obtained from two main sources, animal and mineral. Among the animal phosphates are the bone meals, waste products of the slaughterhouses, and fish scrap. The important mineral phosphates are rock phosphate, basic slag, and acid phosphate.

Phosphorus<sup>1</sup> from mineral sources is but slightly soluble in water. When treated with an acid like sulphuric acid, however,

<sup>1</sup> In the publications on fertilizers, phosphorus is expressed in terms of so-called phosphoric acid. In this text it is given as phosphorus, in accordance with the best usage. To convert values for phosphorus into values for phosphoric acid, multiply by 2.29. To convert phosphoric acid values into phosphorus values multiply by .43.

a part of the phosphorus is changed to a form that is slowly soluble in soil water which contains carbonic acid. Phosphorus in either of these forms is considered available to plants (Fig. 43). It is known commercially as available phosphorus and commands a higher price than does phosphorus in an unavailable form.

**120. Bone meal.** There are two types of bone meal on the market, raw bone and steamed bone. Raw bone is the fresh

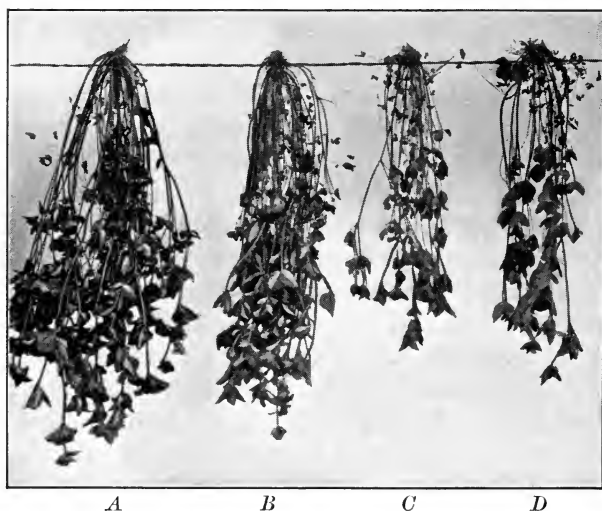

FIG. 43. Response of red clover to different soil treatments

*A*, legumes, lime, phosphorus, and potassium ; *B*, legumes, lime, and phosphorus ;  
*C*, no treatment ; *D*, legumes and lime

bone finely ground. Steamed bone is bone after the fat and gelatin have been extracted by steam. Raw bone contains about 4 per cent of nitrogen and 9 per cent of phosphorus. Steamed bone contains about 1 per cent of nitrogen and 10 to 12 per cent of phosphorus. It is more finely ground than the raw bone, and the phosphorus is somewhat more readily available than in raw bone. The phosphorus in both these products is largely insoluble, but it is much more readily available than that in rock phosphate.

**121. Phosphate rock.** Rock containing a large amount of phosphorus is found in the Carolinas, Florida, Tennessee, and in other Southern as well as some Western states. The most important phosphate deposits in the world are found in these states. Standard grades of rock phosphate contain from 12 to 13 per cent of phosphorus. The raw phosphate rock, very finely ground, is used to a considerable extent as a fertilizer. Large quantities also are treated with sulphuric acid for making acid phosphate. The raw rock acts slowly and should be used only on soils that contain considerable organic matter, or should only be applied with a green-manure crop (Fig. 44), barnyard manure, or decaying sod, in order that the phosphorus be made available to plants.

**122. Acid phosphate.** Acid phosphate contains from 5 to 7 per cent phosphorus, most of which is soluble. Acid phosphate is used to a large extent in the Eastern and Southern states. It is also one of the most important materials used in compounding mixed fertilizers.

**123. Basic slag.** Basic slag, sometimes known as Thomas meal, is a by-product of the steel mills. It is ground to a fine powder and used in much the same way as raw phosphate rock. A good grade of slag contains about 8 per cent of phosphorus in a form somewhat more available than that in raw rock.

**124. Where phosphates are used.** Phosphatic fertilizers are the most widely used fertilizing materials. The acid phosphate, the quick-acting form of phosphorus, is most extensively used in the Southern and Eastern states. The bone meals and the basic slag are moderately quick acting, the former being used largely in central United States near the large slaughterhouses, the latter in European countries. The raw phosphate rock is used mainly in the corn belt.

**125. Potassium fertilizers.** The main source of potassium fertilizers for the world is the Stassfurt mines of Germany. It is calculated that there is sufficient potash in these mines to last the world five hundred thousand years at the present rate of consumption. The most common crude salt is known as *kainite*, which contains approximately 10 per cent of potassium. The

crude salts from the mine are dissolved and recrystallized, thus securing purer forms of potash salts for the fertilizer trade.

**126. Potassium chloride.** Potassium chloride, otherwise known as muriate of potash, is the most common of the purified potash salts, and contains about 42 per cent of potassium. It has a somewhat injurious effect upon the quality of potatoes and tobacco, but for other farm crops, it is a very satisfactory form to use.



FIG. 44. Wheat under different kinds of soil treatment

The field at the right had no soil treatment; on that at the left a crop of legumes was plowed under, and phosphorus and lime were used

**127. Potassium sulphate.** Potassium sulphate is another form of potash salt secured by purifying the raw salt from the potash mines. It contains about 43 per cent of potassium in its commercial form. It is extensively used as a fertilizer and as an ingredient of mixed fertilizers. It has no injurious effect upon the quality of any of the farm crops and is the principal potassium fertilizer used on potatoes and tobacco.

**128. Wood ashes.** Wood ashes, on account of their abundance and cheapness, were formerly much used in the Eastern states. Fresh hardwood ashes contain about 30 per cent of lime. The potassium is in the form of carbonate, which is alkaline, and this with the lime tends to keep the soil sweet. Used in large quantities, however, ashes are injurious to germinating seeds.

**129. The use of potash.** Potash fertilizers are used in the United States mainly in mixed fertilizers and on special crops, such as potatoes and tobacco, which require much potassium in their growth. In European countries near the potash mines they are used more extensively on general crops. The forms having the widest use are the chloride and sulphate of potash, which are perfectly soluble and the potassium readily available to plants. The rate of application of either of these varies for different uses from twenty-five to two hundred pounds per acre.



FIG. 45. Fertilized and unfertilized garden crops

The crops at the right were fertilized, those at the left were not. (Photograph from Rhode Island Agricultural College)

**130. Mixed fertilizers.** Large quantities of fertilizer are placed on the market as "mixed" fertilizers. When fertilizers contain nitrogen, phosphorus, and potassium, they are known as "complete" fertilizers. It is common to sell fertilizers of this sort under such names as "grain growers," "potato fertilizers," "lawn fertilizers," and "wheat growers." As a rule, the proportions of the elements contained in such fertilizers are planned in an attempt to bring the largest money return from these respective crops when grown on poor soils (Fig. 45). Fertilizers are also often sold under trade names, such as "Anchor Brand," "Ox Brand," or "Western Brand." Since it is impossible for the same fertilizer to be best for all soils, and since farmers often do not know the needs of their soils,

nor the meaning of fertilizer formulas, there is much fertilizer used that is not suited to the soil or crop.

**131. What a fertilizer formula means.** One of the most common types of fertilizer on the market is one having a composition of about 2 per cent ammonia, 8 per cent of so-called available phosphoric acid, and 2 per cent of water-soluble potash. It is common in the trade to speak of such a fertilizer as "two-eight-two." In the same way, one containing 3 per cent of ammonia, 10 per cent of available phosphoric acid, and 5 per cent of water-soluble potash is called a "three-ten-five."

Fertilizers usually contain a large amount of inert matter, commonly known as a "filler," along with a comparatively small amount of plant food, since it is necessary to have a certain bulk in order to apply the fertilizer evenly.

**132. States control the sale of fertilizers.** All states in which fertilizers are used to any extent have laws regulating the sale of commercial fertilizers. The manufacturer is required to stamp the composition of the fertilizer on each bag, and penalties are provided for false branding. Formerly it was the custom among manufacturers to make the statements of analyses more complicated than is necessary.

The important things are the ammonia (which contains the nitrogen), the available phosphoric acid, and the potash, and the statement should indicate clearly the amounts of these things.

**133. How to compute fertilizer values.** The market value of a fertilizer is based upon the per cent and availability of the plant-food elements it contains. In calculating values it is common among fertilizer dealers to speak of "units" of plant food. A unit represents 20 pounds of a given element per ton, or 1 per cent. Nitrogen can be delivered to the farmer in quickly available form for 20 cents a pound, or \$4 a unit. On the same basis available phosphoric acid is worth 6 cents a pound, or \$1.20 a unit. Insoluble phosphoric acid is worth 2 cents a pound, or 40 cents a unit, and water-soluble potash is worth 6 cents a pound, or \$1.20 a unit. Thus the value of a fertilizer of known composition would be determined readily as follows :



Nitrogen . . . . .	1.65 units @	\$4.00	\$6.60 per ton
Phosphoric acid (available)	8.00 units @	1.20	9.60 per ton
Phosphoric acid (insoluble)	8.00 units @	0.40	3.20 per ton
Potash . . . . .	2.00 units @	1.20	2.40 per ton
Value . . . . .			<u>\$21.80 per ton</u>

It will be seen that the delivered price of the fertilizer is \$21.80 per ton. These figures will not necessarily hold throughout the United States, but they are representative and illustrate the method of calculating fertilizer values.

**134. Home mixing of fertilizers.** It is sometimes cheaper for farmers to secure the raw materials and mix their own fertilizers than it is to buy them ready mixed. Such a plan has the further advantage of enabling the farmer the better to adapt the fertilizer to the needs of the soil and the requirements of the crop. For men who are well informed on the matter of fertilizers and who use considerable quantities of such material, home mixing is usually best.

**135. Methods of applying fertilizers.** To obtain the best results, fertilizers must be evenly distributed. This is usually done by the use of a fertilizer drill or fertilizer scatterer. In the case of intertilled crops, such as corn, there are devices for distributing fertilizers in the row or hill. Fertilizers are applied in amounts varying from 50 pounds to 1000 pounds per acre, but from 150 to 400 pounds is a fair application for general crops.

**136. Fertilizers for different crops.** The soil, as well as the crop, determines the kind and amount of fertilizer to apply. In general, sandy soils are most in need of complete fertilizer, and the dark clay-loam soils are usually in need of nitrogen and phosphorus. On average loam soil which is only fairly fertile, wheat will respond best to the application of a fertilizer containing considerable amounts of readily available phosphates, such as acid phosphate, bone meal, or highly phosphatic mixed fertilizer. A fair amount of nitrogen will also usually be profitable, and a small amount of potash will improve the quality of the grain. Corn responds to all three fertilizer elements (Fig. 46), and on

poor soils a liberal application (from 300 to 400 pounds per acre of a high-grade complete fertilizer) is best. The same is true of cotton. Potatoes and tobacco require a fertilizer high in potassium. Oats and rye are similar to wheat in their fertilizer requirements (Fig. 45), but the economic returns are less.

**137. Lime.** Lime is not regarded as a fertilizer in the true sense of the word, as it is not added for the purpose of supplying plant food. Calcium, the important constituent of lime,



FIG. 46. Growing corn by use of fertilizers

This corn, grown on the farm of Georgia State College, produced 100 bushels per acre

is an element of plant food, but almost all soils contain enough of this element in proper form for plant use. If applied in large quantities, lime improves the mechanical condition of soils by making stiff, heavy soils lighter and more mellow, and by making sandy soils more compact. Lime also promotes favorable chemical changes by favoring the development of beneficial bacteria, by preventing phosphorus from uniting with iron and aluminium (in which combination it would be securely locked from crops for a long time), and by helping to make the potash in the soil available. It is also necessary in the changing of the nitrogen of ammonia to nitrates. Lime is the most effective agent with which to improve sour, or acid, soils.

**138. What soils need lime.** Land that has been heavily cropped for a long time is likely to need lime. The soils of regions of heavy rainfall are more apt to be deficient in lime than are those of drier regions, because of the leaching effect of the rains. Soils upon which legumes thrive, especially alfalfa or red clover, are certain to have plenty of lime. On the other hand, land that produces redtop, sorrel, or dock, and on which legumes do not thrive, is very apt to need lime or drainage, or both.

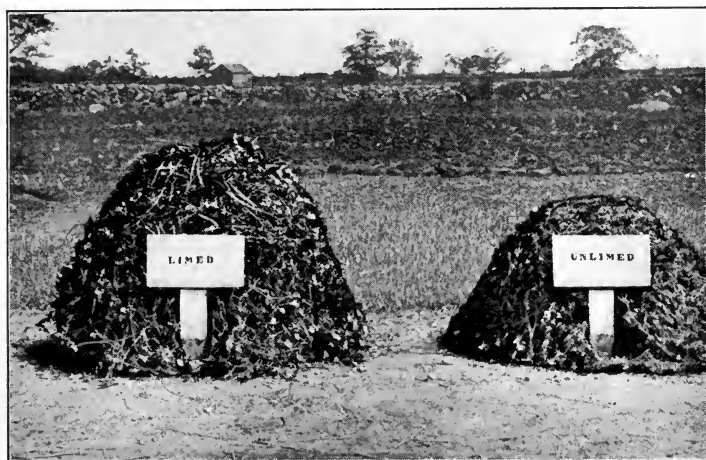

FIG. 47. Effect of liming alfalfa soils. (Photograph from Rhode Island Experiment Station)

**139. The kinds of lime to use.** Many of the fertilizers in common use, as wood ashes, phosphate rock, basic slag, and marl, contain a considerable quantity of lime; but most of the agricultural lime is derived from limestone and is applied in the form of quicklime, freshly burned limestone, or in a raw state after having been finely ground (Fig. 47). Quicklime has almost double the sweetening power of ground limestone, 56 pounds of the former being equal to 100 pounds of the latter. Quicklime also hastens the destruction of the organic matter in the soil, and by this means, as well as in its action upon the soil

minerals, makes the plant food available. Therefore on stingy soils quicklime may be the form needed ; on friendly soils limestone may be more satisfactory and is always safer.

**140. How and when to apply lime.** Quicklime is usually thrown into small piles in the field and covered with moist soil. In the course of a few days it absorbs sufficient water from the soil to slake it and falls to a fine powder, after which it can be scattered. In some sections the quicklime is ground to a meal, scattered with a special spreader, and allowed to slake on the soil. Lime in any form is applied on plowed land and should be thoroughly mixed into the soil. Quicklime is applied at the rate of from 20 to 40 bushels of 75 pounds each, and ground limestone is applied at the rate of from 1 to 3 tons per acre, 2 tons being the usual amount. In a rotation lime is usually applied just before seeding to wheat. This is especially to be recommended if clover is to be sown on the wheat the following spring.

**141. Do commercial fertilizers and lime hurt the soil ?** Quicklime has long been regarded as a soil stimulant in the sense that it helps to release plant food contained in the soil. It should not be used except in a rational system of crop rotation and where manures have a prominent part ; otherwise, it is likely to be positively hurtful to the soil. This idea is well expressed in the old saying "The use of lime enriches the father and impoverishes the son," but this statement applies less to limestone than to lime.

It is a common notion that commercial fertilizers, too, act as soil stimulants and that their continued use is injurious to the land. They are, however, in no sense soil stimulants, and their value lies not in unlocking food already contained in the soil, but in the plant food they themselves supply. If the farmer is careful to maintain a proper supply of organic matter in the soil through the use of barnyard and green manure, he may safely use commercial fertilizers indefinitely. The rational use of commercial fertilizers requires that they be used in connection with, and not as substitutes for, green crops and barnyard manures.

## QUESTIONS AND PROBLEMS

1. What are the four high-grade nitrogenous commercial fertilizers, and what is the per cent of nitrogen in each?
2. Name four important phosphatic fertilizers, the source from which each is derived, and the condition under which each may be used to the best advantage.
3. Where is the greater part of potassium fertilizer obtained? What are the probabilities of early exhaustion of the supply?
4. What is meant by complete fertilizer? What is meant by two-eight-two or three-ten-five fertilizer?
5. Assuming that ground limestone costs \$1.20 per ton delivered at your railway station, and assuming that a farmer, at a cost of \$4 per day, can haul and scatter two loads of two tons each per day, what is the cost of liming a twenty-acre field?
6. Estimating corn at 50 cents per bushel, how much increase in the first corn crop would be required to pay the cost of the liming?
7. What other benefits besides increase of the corn crop might result from liming the soil?
8. Under what conditions may the use of commercial fertilizer be continued indefinitely without injury to the soil?

## EXERCISES

1. **Study of fertilizers.** Secure samples or descriptions of several kinds of fertilizing materials and mixed fertilizers. Learn the approximate composition of each and the general appearance. Figure the approximate market value of each after the manner indicated on page 109.

2. **Effect of fertilizer upon plant growth.**

MATERIAL: Two one-gallon flower pots; clean, washed sand; a small quantity of a complete fertilizer.

Fill two one-gallon flower pots with clean, washed sand, and settle by jarring until the sand is a half inch below the top of the pots.

To one pot add 6 grams of a complete fertilizer containing from 2 to 3 per cent nitrogen, from 8 to 12 per cent available phosphoric acid, and from 3 to 5 per cent potash, mixing thoroughly with the top four inches of sand. The mixing is best done by removing the top four inches of sand to a paper or oilcloth, mixing the fertilizer with it, and

replacing in the pot. Add just enough rain water to each pot to moisten the sand. Plant four kernels of corn in each pot. Place in a warm window and keep each pot well moistened. Observe the growth of the corn in each pot for four weeks.

#### REFERENCES

- AGEE, ALVA. Crops and Methods of Soil Improvement, chaps. xvi, xvii, and xviii. The Macmillan Company.
- BURKETT, C. W. Soils, chaps. xxiv, xxv, and xxvi. Orange Judd Company.
- HOPKINS, C. G. Soil Fertility and Permanent Agriculture, chap. xxvii. Ginn and Company.
- LYON, T. L., and FIPPIN, E. O. Soils, pp. 319-350. The Macmillan Company.
- SNYDER, HARRY. Soils and Fertilizers, chaps. ix and x. Chemical Publishing Company.
- VAN SLYKE, L. L. Fertilizers and Crops, chaps. xx, xxi, xxii, xxiii, xxiv, and xxv. Orange Judd Company.
- VIVIAN, A. First Principles of Soil Fertility, chaps. xvii, xviii, xix, xx, xxi, and xxii. Orange Judd Company.
- VOORHEES, E. B. Fertilizers, chaps. iii, iv, and v. The Macmillan Company.
- Farmers' Bulletin 259*, United States Department of Agriculture.
- Sources of Commercial Fertilizers (includes illustrated matter relative to seaweeds as sources of fertilizers). United States Congressional House Document 181, 55th Congress, 3d Session.



## CHAPTER XI

### RELATION OF TYPE OF FARMING TO SOIL FERTILITY

The increase of stock and the improvement of the land are two events that must go hand in hand, and of which the one can nowhere much outrun the other. — ADAM SMITH in "Wealth of Nations"

**142. Returning the fertility removed in crops.** No system of agriculture is permanent that does not return to the soil as much plant food as is removed by the crops grown. From the results of the experiments conducted by the Illinois and Missouri experiment stations it was seen that under a good cropping system the productiveness of the land was maintained on a much higher plane than where corn was grown continuously. The experiments also showed that where manure was added to the rotation, much larger yields were obtained.

Crop rotation, then, is only one of the steps necessary in maintaining the productiveness of soils; and the proper use of manures or fertilizers is just as important. It is true that if the supply of organic matter and nitrogen is maintained by green manures and by crop residues, it will require many years for good soils to show a material decrease in fertility. But in the end any system of farming that does not provide for the return to the soil of as much plant food as is removed by the crops will deplete the fertility of the soil.

**143. Feeding the crops to live stock.** One very practical way of returning to the soil a large part of the plant food removed in the crops is to feed the crops to live stock, taking care that

the manure is saved and properly used (Fig. 48). The manure contains about one third of the organic matter contained in the crops fed, the remainder being disorganized in the digestive processes of the animal. If we should feed the entire crop — grain and straw or fodder — to stock and apply the manure, we should lose two thirds of the organic matter, and the supply in the soil could not be maintained. Under average conditions, however, only about half the total weight of the crop produced is fed to animals, the remainder being used as bedding or being left on the ground in the form of stubble or stalks to be worked into the soil.

**144. Live-stock farming and soil fertility.** It is possible with a crop rotation of corn, oats, and clover, for instance, where the crops are fed to stock and the manure is returned to the land, to maintain the supplies of nitrogen and organic matter in the soil (Fig. 49). For example, assume an acre-yield of sixty bushels of corn, fifty bushels of oats, and one and one-half tons of clover hay for the first cutting, with a second clover crop of three quarters of a ton. Let us assume, further, that the ear corn is harvested and the cornstalks remain in the field; that the grain of corn and oats as well as the first crop of clover is fed; that the oat straw is used as bedding in the feed-sheds and stables; and that the second crop of clover remains on the land. The gain or loss of plant food on an acre of soil for one round of the rotation may be shown in the tables on page 118.

It will be observed that there is an actual gain of 45 pounds of nitrogen and a loss of nearly 6 pounds of phosphorus and of almost 10 pounds of potassium. In this estimate no loss of nitrogen is charged to the clover crop, as the nitrogen in the tops, or hay, of clover is about equivalent to that secured from the air. Consequently the nitrogen in the manure from the clover hay, as well as that in the second crop, can be considered as a direct gain to the soil. The nitrogen added by clover should be checked against some losses occurring through nitrogen passing off into the air and by leaching.





FIG. 48. Indications of poor farming

Poor farmer, poor barn, poor care of manure, poor soil, and poor crops are companions. The manure is left under the melting snow, and much of its value is lost.  
(Photograph from University of Ohio)

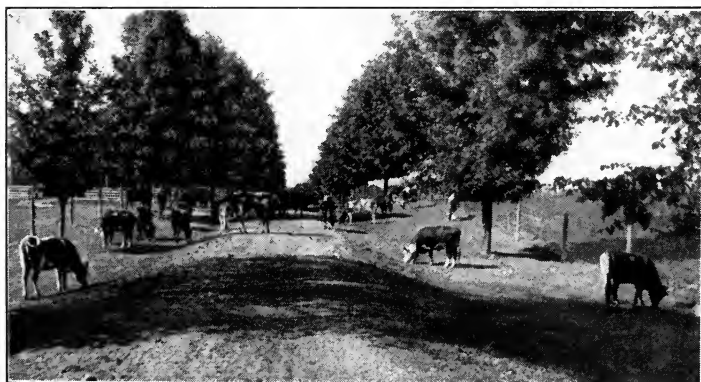

FIG. 49. The difference is in the farming

Plenty of live stock to maintain a well-balanced farm practice. (Photograph from Michigan Agricultural College)

LOSS IN CROPS<sup>1</sup>

CROP	NITROGEN	PHOSPHORUS	POTASSIUM
	<i>Pounds</i>	<i>Pounds</i>	<i>Pounds</i>
Corn, 60 bushels . . . . .	60	10.2	11.4
Oats, 50 bushels . . . . .	30	5	5.8
Clover hay (first crop, 1½ tons) .	0	7.5	45
	<u>90</u>	<u>22.7</u>	<u>62.2</u>

## RETURNED TO SOIL

	NITROGEN	PHOSPHORUS	POTASSIUM
	<i>Pounds</i>	<i>Pounds</i>	<i>Pounds</i>
Manure from 60 bushels of corn .	42	7.5	9.6
Manure from 50 bushels of oats .	21	3.7	4.7
Manure from 1½ tons of clover .	42	5.6	38.2
Second crop of clover, ¾ ton . .	30	0	0
	<u>135</u>	<u>16.9</u>	<u>52.5</u>
Gain or loss to soil	+ 45	- 5.8	- 9.7

Under such a system, therefore, the supply of nitrogen and organic matter of the soil can be maintained or even increased. The losses are in phosphorus and potassium, which must be secured from outside sources, such as fertilizers or purchased feeds. Under such a system of stock farming, particularly on soils naturally well supplied with lime, phosphorus, and potassium, it would require many years to show a decrease in soil fertility.

**145. Grain farming and soil fertility.** It is possible through the use of green manure and commercial fertilizers to maintain soil fertility under a system of grain farming, where all the grain is sold off the land except what little is used to feed working stock. This plan necessitates, first, the growing of certain legume

<sup>1</sup> The figures on this page are based on a return of 70 per cent of the nitrogen, 75 per cent of the phosphorus, and 85 per cent of the potassium contained in the crop fed, such as is possible under the best systems of handling manure.

crops to be turned under, in order to maintain the supply of nitrogen and organic matter; and, second, the purchase of phosphorus and sometimes of potassium to replace that removed in crops. It requires, further, that all straw and corn stover be returned to the land. This may be illustrated with a rotation of corn, oats, and clover, all grain being sold, and the corn stover and oat straw being returned to the land. The first crop of clover must be cut somewhat earlier than usual and left to lie on the ground, the second crop coming up through it and being cut for the seed, the threshed clover straw being returned to the land.

**146. Balance of gain and loss.** The effect of such a system on an acre of soil during one round of the rotation is shown below :

## LOSS IN CROPS

CROP	NITROGEN	PHOSPHORUS	POTASSIUM
	<i>Pounds</i>	<i>Pounds</i>	<i>Pounds</i>
Corn, 60 bushels . . . . .	60	10.2	11.4
Oats, 50 bushels . . . . .	30	5	5.8
Clover seed, 2 bushels . . . . .	3.5	1	1.5
Total . . . . .	93.5	16.5	18.7

## RETURNED TO SOIL

CROP	NITROGEN	PHOSPHORUS	POTASSIUM
	<i>Pounds</i>	<i>Pounds</i>	<i>Pounds</i>
First crop of clover, 1½ tons . . . . .	60	0	0
Second crop of clover straw, threshed, ¾ ton . . . . .	30	0	0
Total . . . . .	90	0	0
Gain or loss to soil . . . . .	- 3.5	- 16.5	- 18.7

Under this system the nitrogen supply is nearly maintained by the clover, if we assume that the clover growing in the oat stubble during the first year is checked against the loss of this element through leaching and the loss through the

escape of some nitrogen into the air. This leaves all of the first crop of clover on the ground, a circumstance which adds much more organic matter than if it were fed to stock and the manure returned to the land.

The loss in phosphorus and potassium is larger than under live-stock farming, and on poor soils or under permanent systems of agriculture these must be purchased in commercial fertilizers. Some such system of grain farming and green manuring can be made remunerative where properly handled. Older countries make much wider use of such systems than does the United States.

**147. The business side of maintaining soil fertility.** It is easier to plan a system of soil building than it is to put this plan into effect. The one requires knowledge, the other knowledge and business judgment. To handle worn-out soil so as to build up its fertility and make a living from it at the same time is a very difficult matter. Both capital and time are required. Even with abundant capital and time there are still many problems whose solution requires keen intellect and the best of business judgment. Too often, however, the farmer neglects to provide the green manure crop or fails to purchase the required amount of commercial fertilizer. A system of live-stock and grain farming is safest and most profitable for most regions of the United States.

#### QUESTIONS AND PROBLEMS

1. What proportion of the organic matter may be returned to the soil when the crops are fed to live stock?
2. What proportion may be returned to the soil when a system of grain farming is followed?
3. Explain fully how it is possible to maintain the fertility of the soil on a live-stock farm.
4. Explain fully the means necessary to establish a permanent system of agriculture on a grain farm.
5. What percentage of the elements of plant food contained in the feed may be returned to the soil in live-stock farming? in grain farming?

## EXERCISES

Secure the latest available report of the live-stock census and crop reports for your county or township, and determine and prepare a table showing the following:

1. The number of acres of each of the leading grain crops.
2. The total yield in your county of each of the leading crops.
3. The average acre-yield of each of the leading crops.
4. The number of animals of each of the leading kinds.
5. The total value of the manure produced by the live stock in one year.
6. The average value of this manure per acre.
7. The total amount of nitrogen, phosphorus, and potassium removed from the soil (1) by the grain crops, (2) by the hay crops, and (3) by both.
8. The total value, at prices used in the text, of these elements removed.
9. The value of these elements per acre.
10. If all the manure were returned to the land each year, what would be the loss per acre of land through removing the crops? What would it be if only half the manure were put upon the land?

## REFERENCES

- LONG and PERCIVAL. Common Weeds of Farm and Garden. Frederick A. Stokes Company.
- PAMMEL, L. H. Weeds. Orange Judd Company.
- SHAW, THOMAS. Weeds and how to Eradicate them. Webb Publishing Company.
- SNYDER, HARRY. Soils and Fertilizers, chap. xii. Chemical Publishing Company.
- THORNE, C. E. Farm Manures, chap. xiii. Orange Judd Company
- WARREN, G. F. Farm Management, chap. v. The Macmillan Company.
- WHITSON and WALSTER. Soils and Soil Fertility, chaps. v, xviii, xix, and xx. Webb Publishing Company.
- Planning a Cropping System, *Bulletin 102*, Pt. III, Bureau of Plant Industry, United States Department of Agriculture.
- Farm Management, *Bulletin 236*, Bureau of Plant Industry, United States Department of Agriculture.
- Replanning a Farm for Profit, *Farmers' Bulletin 370*, United States Department of Agriculture.



## CHAPTER XII

### DRAINAGE, IRRIGATION, AND DRY FARMING

#### I. DRAINAGE

**148. Effects of drainage.** Soils in which water stands near the surface for a considerable time during the growing season are benefited by drainage. Such soils are usually either so level that water does not flow off the surface or so fine-grained that water cannot flow out readily after heavy rains. The standing water shuts out the air and furnishes a condition that is not favorable to the growth of roots (Fig. 50). It also hinders the bacteriological processes necessary to a productive soil. It makes the soil cold and delays its preparation for a crop.

Tile laid beneath the surface remove the excess water and bring in air, while at the same time they admit air to the lower areas of the soil through the openings of the tile themselves. Water falling as rain upon the soil displaces the air, and as it drains out, fresh air comes in. Probably the most important natural cause of soil aëration is the diffusion of gases, and the most important means by which the farmer can further soil aëration are cultivation, addition of vegetable matter, and tile drainage.

**149. Kinds of drainage.** There are two general methods of draining land—surface drainage and tile drainage. Surface drains are used as a cheap means of ridding the land of the surface water. Tile drains are pipes laid at a depth of three or four feet to remove the standing water from the soil. The

disadvantage of surface drains is that they occupy considerable land, favor surface washing, and in fine-grained soils like clay do not lower the water table to the depth required by growing crops. Tile drains have the disadvantage of being expensive, but they are efficient. Red-burned clay tile are commonly used for draining land, and in recent years concrete tile have come into limited use.

The depth at which tile are laid varies from two to four feet, three feet being the usual depth. The more porous the soil the deeper and the farther apart the tile may be laid. Some of the essential things in the laying of tile drains are to have a free outlet into a drainage channel, to have tile that are hard burned, and to have them carefully laid with uniform fall sufficient to carry away the water.



FIG. 50. Results of good and poor drainage

On left, corn planted in pot having good drainage; on right, corn planted in pot having poor drainage. Both pots had the same kind of soil and received the same amounts of water

The usual fall is from four to six inches per hundred feet, although a fall of only two inches is allowable (Fig. 51).

Ordinarily the tile used are a foot in length and are laid end to end. The water enters through the cracks, or joints, between the tile and does not pass through the sides of the tile. The diameter of the tile used is commonly from four to six inches, although where several lines of smaller tile empty into a main tile, the main tile should be from eight to sixteen inches in diameter.

**150. Lands needing tile drainage.** Tile are most extensively and most profitably used on the prairie lands of Illinois and Iowa and on the level land of Wisconsin, Indiana, Ohio, and New York. Some level lands, however, are so fine-grained that water

will pass through them to the tile very slowly. On such lands it is necessary to lay a larger number of lines of tile to a given area than on more porous lands. Tile are sometimes laid on rolling lands to aid in preventing surface washing and erosion.

They are also often laid across hillsides which are wet because of water seeping out on the surface in draining from higher levels. Lands on which tile pay best are usually those which are porous enough to drain well, but which are wet because they are level.

The cost of tiling varies from \$5 to \$40 an acre, according to the size of tile used, the distance the lines are apart, and the depth at which the tile are laid.

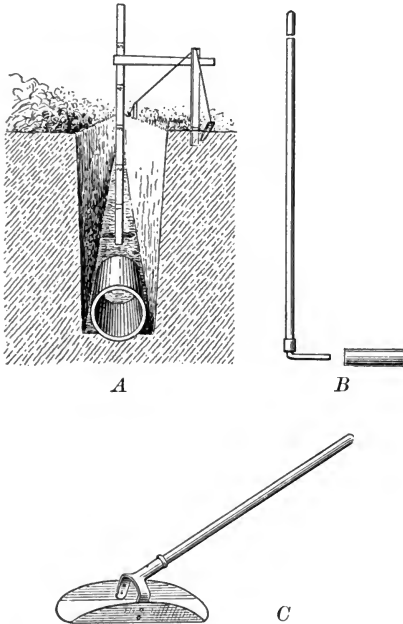

FIG. 51. Section of a tile drain, and tools for laying drains

A, ditch ready for laying tile, one tile in place; the grading line and upright measuring stick make it possible to secure the desired evenness in fall of the ditch; B, a tile hook for laying the tile; C, a grading scoop for finishing the bottom of the ditch

## II. IRRIGATION

**151. The object of irrigation.** In regions of little rainfall it is necessary to supply water artificially if crops are to be grown economically. The process of bringing water to the land from ponds, rivers,

or wells is known as *irrigation*. Irrigation is ordinarily most profitable where the rainfall is less than sixteen inches. Considerable areas in the western part of the United States—particularly in the Rocky Mountain region and the high plains—have been brought under systems of irrigation (Fig. 52).



Irrigation is sometimes practiced in humid regions with a rainfall of from thirty to forty inches, but this is usually profitable only under systems of intensive farming or where the crops have a high market value. Lands grown to truck crops come in this class, while in certain parts of Europe, where hay is high priced, meadows are profitably irrigated.

**152. How water is applied.** Water is usually brought to the land in canals from streams or lakes and distributed over the



FIG. 52. Irrigating in California

The side, or lateral, ditches carry the water from the supply ditch to the trees. (Photograph from Office of Experiment Stations, United States Department of Agriculture)

fields in small ditches (Fig. 53). If the crop is one which covers the surface of the ground, such as clover, wheat, or alfalfa, the field is usually flooded. Rice is grown on lands which can be kept covered with water during the first part of the crop's growth (Fig. 54). Where crops are grown in rows and cultivated, the common plan is to run the water down the furrows between the rows and allow it to enter the soil from the furrow. Under special systems of cropping, overhead pipes are installed and the water is sprinkled on the soil in a manner resembling the fall of rain.

Where sufficient water is available for irrigation in the arid parts of the country, farming under irrigation is very profitable, as it enables one to control the moisture supply in the soil to better advantage than where one must depend upon rainfall. Even when all the available water is used, only about 10 per cent of the total area of the dry lands of the United States can ever be irrigated.

### III. DRY FARMING

**153. What is dry farming?** The term *dry farming* is applied to a system in use in regions where the moisture supply is less than that ordinarily used in crop growth. Plants cannot be grown

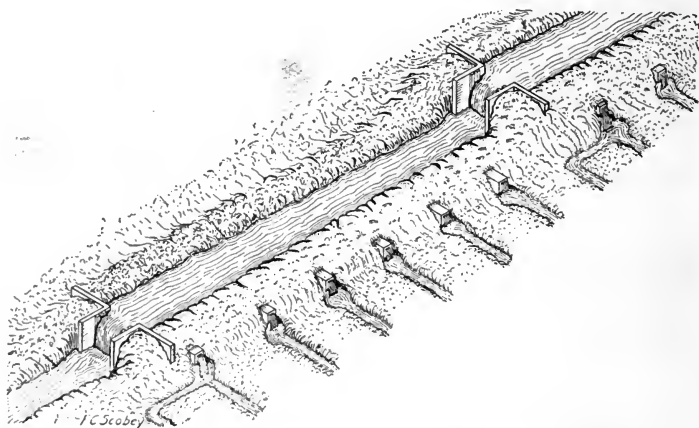

FIG. 53. Distributing water

Part of the water is diverted through lateral ditches to the fields. (Photograph from Office of Experiment Stations, United States Department of Agriculture)

without water, but it is possible to grow them with a limited supply when drought-resisting varieties are selected, and when the rain that falls is caught and conserved in the soil. In some areas the rainfall is not sufficient to grow a profitable crop each season, even when these precautions are taken. In such cases the moisture that falls through two years is stored in the soil for the growth of one crop. Dry farming has been practiced in

some parts of the world for hundreds of years. In China, wheat has been grown for many centuries without irrigation under a yearly rainfall of less than 20 inches. In the United States, dry farming was first established in Utah, where it has been successfully practiced for the last fifty years.

**154. Dry-farming areas.** With a rainfall of less than 30 inches, especially where the seasons are long and evaporation is high, lack of moisture is usually the factor that determines the yield of crops. Nearly one half of the United States receives less



FIG. 54. Pumping water for irrigating rice in Japan

than 20 inches of rainfall annually, and one tenth of the United States receives between 20 and 30 inches. There are three distinct dry-farming areas: first, the Pacific-coast region, represented by the states of California, Oregon, and Washington; second, the Intermountain region, represented by the states of Idaho, Nevada, Montana, Wyoming, Utah, Colorado, Arizona, and New Mexico; third, the Great Plains region, represented by the states of North Dakota, South Dakota, Nebraska, Kansas, Oklahoma, and Texas. In the Columbia River basin, with a rainfall of from 10 to 12 inches annually, it is estimated that

over 2,000,000 acres are now in dry farms. Here the common practice is to sow one half of the farm to grain and to allow the other half to lie in fallow. In the Great Plains region a larger seasonal rainfall is required for successful farming than in most of the Rocky Mountain states, due to a longer growing season and a higher rate of evaporation.

**155. Rainfall and other climatic conditions.** The manner in which the water is distributed through the different seasons of the year is important as affecting farming under dry-land conditions. On the Pacific coast the rain falls almost entirely during the winter.



FIG. 55. Autumn tillage to prevent blowing and to hold moisture

In the Intermountain region the greatest precipitation occurs during the late winter and early spring. In the southern part of the area, particularly in Arizona, the rainfall is divided into two periods. The first rainy season occurs during the winter, and the second, which is larger, during July and August. In the Great Plains region the rainfall occurs during the late spring and early summer, and the winter is usually very dry.

The rate at which evaporation takes place has a marked influence upon the amount of rainfall required for successful dry farming. In the southern part of the dry-land area, where the summers are warm, — and particularly in the southern part of the Great Plains region, where hot, dry winds accompany the warm weather, — the rate of evaporation is much higher than in the northern part of the region, where the weather is cooler and the air more humid. The evaporation from a free water-surface at Garden City, Kansas, is twice as great as at Williston, North Dakota.

**156. Conserving moisture.** In dry farming it is necessary to choose a soil that has capacity to absorb water rapidly and to hold it well. A heavy clay soil absorbs water too slowly, packs upon drying, and is so difficult to work that it is unsatisfactory for dry farming. A sandy soil — especially when the subsoil is very sandy — absorbs water readily, but permits water to percolate so deeply that it passes beyond the reach of the roots of plants. Soils that are shallow or have hardpan layers in the upper subsoil are unsatisfactory because such soils do not permit of deep root growth. An ideal dry-land soil is a sandy or silty loam that has a uniform texture to a depth of from ten to fifteen feet. A soil of this character absorbs water rapidly, retains it well, and permits the roots of plants to grow deeply, all of which characteristics are essential to success in dry farming.

In handling soils under dry farming two facts should be constantly kept in mind: first, during the rainy season the soil should be kept in such condition that the largest possible quantity of the rainfall will be absorbed and held by the soil; and second, the methods of cultivation should be such as to prevent as fully as possible the loss of water by weed growth and by evaporation. In the Pacific coast states it is advisable to plow deep in the late fall so that the soil will absorb the rain that falls during the winter months (Figs. 55 and 56). In the Intermountain states the plowing should be done in the early spring, while in the Great Plains states the ground should be double-disked early in the spring and plowed in the early summer. The cultivation following plowing in all areas should be such as will prevent weed growth. The disk and the harrow may be used for cultivation in the Intermountain region, where high winds are not common, but in the Great Plains region, where there is danger of the soil blowing, cultivation should be done with a shovel cultivator, spring-tooth harrow, or other implement that leaves the surface rough and the soil cloddy.

**157. Summer fallow.** Where the rainfall is too light to insure a profitable crop each season, as is the condition over much of the dry-land region, summer fallowing is practiced. Summer

fallowing consists of allowing the ground to go uncropped for one season for the purpose of storing moisture. Summer-fallowed ground is usually plowed deep soon after the rainy season begins. At that time the ground is moist and plows well, and the deep plowing provides a rough, open surface that absorbs water readily. The fallow is cultivated frequently enough to prevent weed growth and to keep the surface from crusting. It has been shown that land alternately cropped to winter wheat and summer-fallowed contained on an average of 5.7 inches more



FIG. 56. Listed soil catches and holds winter moisture

water in the upper six feet of soil at seeding time than did land that was cropped each year. The summer-fallowed ground produced, as an average of four years, 26.3 bushels of wheat per acre, while the continuously cropped ground produced but 11.6 bushels. Another experiment showed that, as an average of three years, land summer-fallowed for wheat has produced 12.3 bushels per acre, while early-fall-plowed, continuously cropped land has produced 13.9 bushels, and late-plowed, continuously cropped land has produced 7.5 bushels per acre. Alternate cropping and fallowing is necessary only where the rainfall is very light. Over much of the dry-land area it is necessary to

summer-fallow only once in from three to five or six years if a suitable rotation of crops is carried out. Summer fallow has proved more profitable for winter wheat than for the spring grains or for corn or sorghum.

**158. Crops adapted to dry farming.** Three important factors must be considered in selecting plants to grow under dry-land conditions: first, the plant should have the ability to feed upon moisture stored in the lower subsoil; second, it should make its greatest growth during the season of greatest rainfall; and third, it should be able to use water economically. Wheat is the most successful dry-land crop. It makes its greatest growth during the spring and the early summer, when the largest part of the precipitation falls, and it has the ability to obtain water from deeper in the subsoil than most other farm crops. The Turkey wheats are best adapted to dry-land conditions. These wheats originated in Europe, and have been grown for centuries in areas of light rainfall. The sorghum crops are also suited to dry farming. These crops were developed under semiarid conditions, and while they make their greatest growth during the hotter and drier portion of the growing season, they have great ability to withstand drought and they use water very economically. Oats, barley, and spring wheat are grown successfully in the northern part of the dry-land area. Potatoes also give good results, especially when planted upon summer-fallowed ground.

#### QUESTIONS AND PROBLEMS

1. At what depth are the tile drains of your locality usually placed?
2. If you have an opportunity, observe the results on crops of drained and undrained soil.
3. If one of the farmers of your vicinity has placed his tile drains four feet deep and another three feet deep, compare the results on their crops.
4. If your school is located in a region which farms by irrigation, secure statistics regarding the number of applications of water, the amount of water used, its cost, and the products of these farms, in comparison with the products of those in nonirrigated districts.
5. Where and how long has dry farming been practiced?

6. What are the three distinct dry-farming areas of the United States?
7. In general, what is the annual rainfall required in dry-farming areas? How does this compare with the annual rainfall in your locality?
8. How does the manner in which the rainfall is distributed affect dry farming? How does evaporation affect dry farming?
9. Discuss the different methods for preparing the soil to absorb and hold moisture.
10. Compare the results of alternate cropping of wheat with the results of continuous cropping.
11. Why are certain crops best adapted to dry farming?

#### REFERENCES

- DAVIDSON, J. B. Agricultural Engineering. Webb Publishing Company.
- ELLIOTT, C. G. Practical Farm Drainage. John Wiley & Sons.
- MACDONALD, WILLIAM. Dry Farming. The Century Co.
- SHAW, THOMAS. Dry-Land Farming. The Pioneer Company, St. Paul, Minn.
- SMYTHE, WILLIAM E. Conquest of Arid America. The Macmillan Company.
- WARING, G. E. Tile Drainage. Orange Judd Company.
- WARING, G. E. Draining for Profit and for Health. Orange Judd Company.
- WIDTSOE, J. A. The Principles of Irrigation Practice. The Macmillan Company.
- WIDTSOE, J. A. Dry Farming. The Macmillan Company.
- Agriculture in the Central Part of the Semi-Arid Portion of the Great Plains, *Farmers' Bulletin 215*, Bureau of Plant Industry, United States Department of Agriculture.
- Dry Farming in Relation to Rainfall and Evaporation, *Farmers' Bulletin 188*, Bureau of Plant Industry, United States Department of Agriculture.
- Dry Farming in the Great Basin, *Farmers' Bulletin 103*, Bureau of Plant Industry, United States Department of Agriculture.
- Water Requirements of Plants, *Farmers' Bulletin 284*, Bureau of Plant Industry, United States Department of Agriculture.
- Tile Drainage on the Farm, *Bulletin 524*, United States Department of Agriculture.
- Drainage of Farm Lands, *Bulletin 187*, United States Department of Agriculture.
- Irrigation in Field and Garden, *Bulletin 138*, United States Department of Agriculture.



The Use of Windmills in Irrigation in Semi-Arid West, *Bulletin 394*, United States Department of Agriculture.

Machinery for Small Pumping Plants, *Circular 101*, United States Department of Agriculture.

Measurement and Distribution of Irrigation Water, *Circular 6*, Utah Agricultural Experiment Station.

Methods for Increasing Crop-Producing Power of Irrigation Water, *Bulletin 118*, Utah Agricultural Experiment Station.



## CHAPTER XIII

### CORN

Were a salesman to advertise Indian corn by a new name, recounting its actual merits while ingeniously concealing its identity, either his words would be discredited or he would have an unlimited demand for the seed of this supposed novelty. —HENRY

**159. Historical.** Corn is generally thought to be a native of America, and was probably first cultivated in Mexico about the beginning of the Christian era. Columbus found the Indians growing the crop. It is believed that he first introduced corn into Europe, whence it soon spread into Africa, China, and Asia Minor.

**160. Corn and the colonists.** The Virginia colonists began raising corn under the instruction of the Indians in 1608, and the New England colonists in 1621. The soil farmed by the Pilgrim Fathers was very poor, and the Indians taught them how to fertilize the land by planting a fish about a foot long and weighing nearly a pound in each corn hill. About two thousand fish were required to fertilize an acre. The fish supplied the needed nitrogen and phosphorus, although the nature of this need was not then understood. Tame grasses and clovers, which are so generally used now in raising live stock, had not yet been introduced into this country, and the colonists had little other fodder for their animals than that produced by the corn plant. Thus the corn plant may have been the means of saving some of the early settlers from starvation.



THE JUDGMENT OF EXPERIENCE

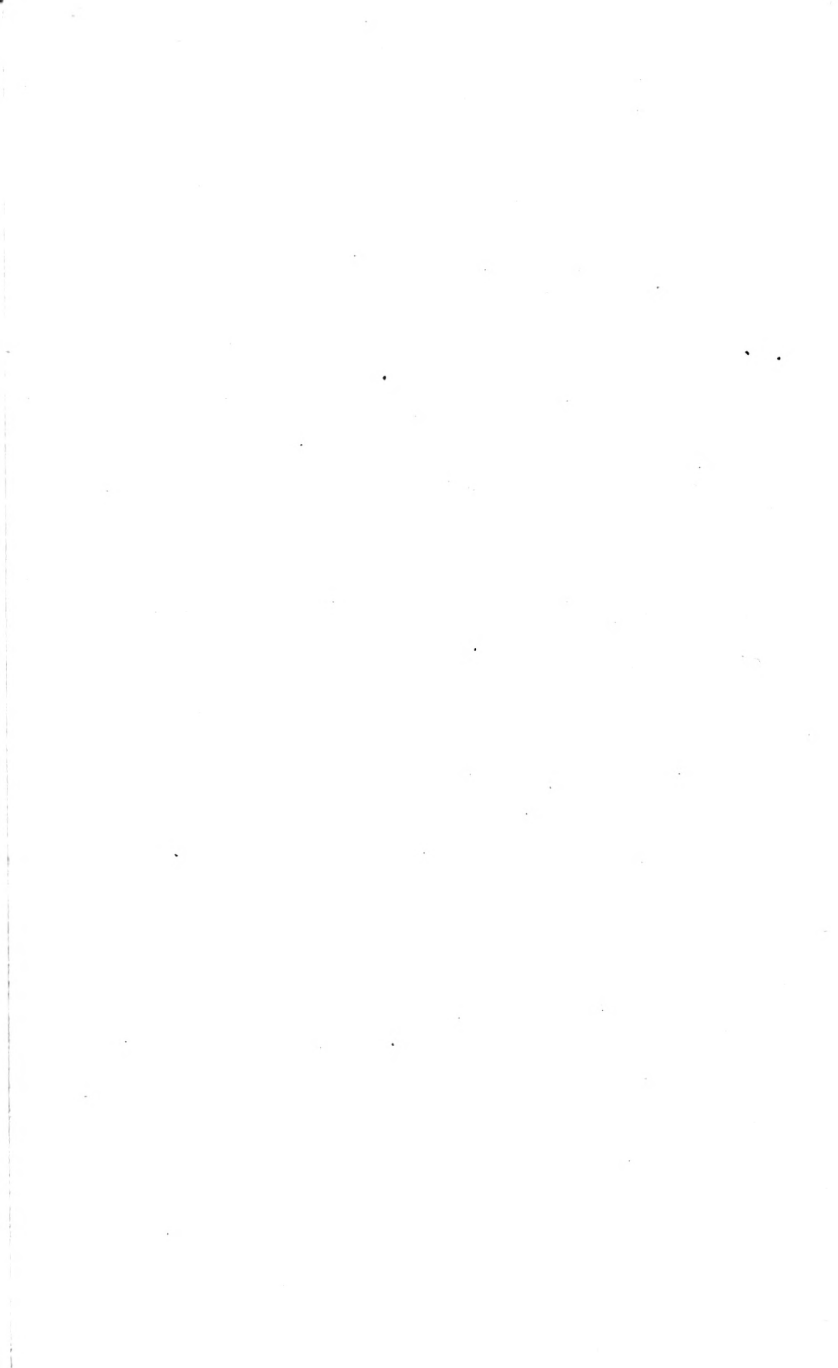

**161. Production and distribution.** Corn is the most productive plant known. The world's corn crop is from 3,500,000,000 to 4,000,000,000 bushels a year. North America produces approximately 78 per cent of this yield; Europe, about 15 per cent; and South America and Australia, the remaining 7 per cent. The principal corn-producing countries outside the United States are Austria-Hungary, Mexico, and Argentina, in the order named. These three countries, together with the United States, produce nearly nine tenths of the world's corn. Seven states, Illinois, Iowa, Missouri, Nebraska, Indiana, Kansas, and Ohio, produce about three fifths of the corn of the United States.

**162. The uses of corn.** Nine tenths of the corn grown in the United States is fed to live stock. The grain is unequalled for fattening all classes of farm stock. The stalks, leaves, and husks are utilized as roughage, either field-cured, preserved in the silo, or fed green. A great variety of products come from the corn plant: corn oil, for salads, paints, lubricating purposes, and rubber substitutes; starch, for laundry purposes; glucose, in the form of sugars, sirups, or candies; breakfast foods; alcohol; by-products, as germ meal, gluten meal, and corn cake (some of which is used for feeding live stock); paper, mattresses, collars, and packing materials, from the stalk and leaves; also part of the materials for powder, dynamite, cellulose, mucilage, and films for cameras and for moving pictures.

**163. Adaptations to climate and soil.** Corn is a temperate-zone plant and, like barley and wheat, has a wide range of growth. During the growing season it requires a high temperature, bright but not too intense sunshine, and a heavy rainfall,

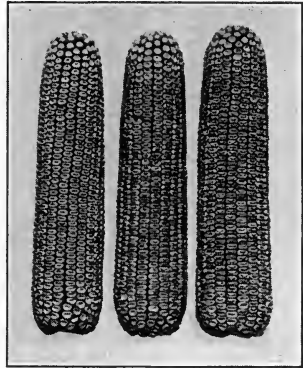

FIG. 57. Reid's Yellow Dent corn

The middle one of these excellent ears is claimed to be the most nearly perfect ear which has been found. (Photograph from Iowa State College)

The best corn soils are well-drained, fertile loams which contain a considerable vegetable matter. Corn is a heavy feeder, likewise a heavy producer, and to produce large yields it is necessary to keep the soil in a high state of fertility by the frequent addition of barnyard or green manure and by the use of legumes in a crop rotation. Commercial fertilizers are extensively applied in the South and East, but on most of the corn-belt soils it has not yet become necessary to use commercial fertilizers.

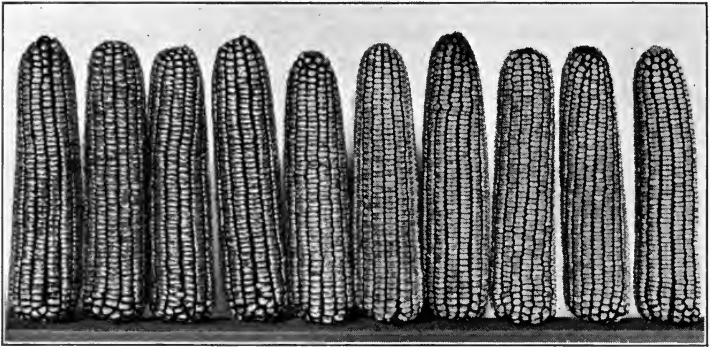

FIG. 58. Weekley's Improved Dent corn. (Photograph from North Carolina Agricultural College)

**164. Types of corn.** There are six types of corn: dent, flint, sweet, pop, soft, and pod corn. The first four only are of commercial importance in America (Fig. 6).

**165. Dent corn.** Probably 90 per cent of the corn of the world is of the dent type (Figs. 57 and 58). The hard, flinty portion of the kernel is at the sides, and the soft, starchy part is at the crown or across the upper portion and in the center of the kernel. In ripening, the starchy portion shrinks, leaving a dent at the summit of each grain. This group is the one commonly cultivated in all parts of the corn-growing region of the United States except in the North.

**166. Flint corn.** The small amount of white or soft starch contained in the kernel is at the center, while the crown and sides are hard or flinty. The kernel does not dent in drying.

The ears have from eight to twelve rows of shallow kernels (Fig. 59). The ears are smaller and more slender than those of the dent corns. Flint corn is grown extensively in New England and in other Northern states, because it matures earlier than most of the dent varieties and is reasonably productive of both grain and fodder.

**167. Sweet corn.** Sweet corn when mature is quite shrunken and wrinkled and is translucent in appearance. As the name suggests, this corn is sweeter than the other types. It is grown mostly for human consumption, to be eaten green, canned, or dried. The grain is filled in part with a watery sugar solution and not principally with starch, as is the case with other types. When the water evaporates in the process of ripening, the grain shrinks and becomes wrinkled.

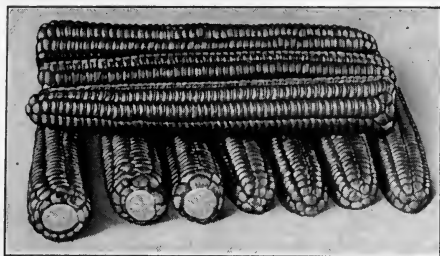

FIG. 59. Flint corn (Early Yellow Canada)  
First prize, New England Corn Exposition, 1910.  
(Photograph from New Hampshire Agricultural  
College)

**168. Pop corn.** Pop-corn kernels resemble the flint type, having a covering of flinty material over the crown and sides and the starchy material at the center. It is grown exclusively for popping.

**169. Soft corn.** The large, rounded kernels of the soft corn varieties are characterized by white, mealy starch throughout the endosperm, the horny starch being entirely lacking. This is grown only in latitudes farther south than the United States, as in some of the countries of Central and South America.

**170. Pod corn.** This corn is grown only as a curiosity. Each kernel is inclosed in tiny husks and the kernels vary greatly, some being dented, others showing the flint characters, and others the soft-corn or sweet-corn characters. It is supposed that all of the modern types of corn came originally from pod corn.

**171. A study of the corn plant.** The stem or stalk of the corn plant ranges from two to twenty feet in height. The outer covering of the stalk is hard and smooth, giving strength to the stem. The stem is not hollow like wheat and oats, but is filled with soft, spongy pith. Distributed through the pith are the circulatory ducts which carry water and food solutions from the roots to the other parts of the plant, and also distribute the organized food from the leaves to the growing parts of the plant.



FIG. 60. Results of poor pollination

When scanty pollination occurs, few ovules are fertilized and few kernels develop

The male flowers are borne at the top of the stalk in the tassel, and the female flowers on the cob (Fig. 16). An average tassel contains as many as thirty million yellowish dustlike particles, called pollen grains, which are blown about by winds, some of them lodging on the moist ends of the silks, where they germinate. The pollen from one plant usually blows to the silks of other plants,

giving what is known as cross-pollination (Fig. 60), which results in cross-fertilization.<sup>1</sup> It is this fact that causes mixture of colors and other characteristics in corn, and makes it difficult to keep varieties pure when growing in adjoining fields. In plants such as corn, which are naturally cross-fertilized, this crossing is necessary to maintain vigor.

**172. How and when to prepare the seed bed.** To supply the most favorable conditions for germination and growth, the ground should be plowed from five to eight inches deep, should

<sup>1</sup> For discussion of fertilization in seed plants, see Bergen and Caldwell's "Practical Botany" or "Introduction to Botany." Ginn and Company.



have a well-pulverized surface and a firm subsurface, and should be amply supplied with moisture and available plant food. The proper depth of plowing varies with conditions; fall plowing should be deeper than spring plowing. An average of five to six inches is a sufficient depth in the spring, whereas the same soils may be profitably stirred to a depth of seven or eight inches in the fall. Harrowing after each half day's plowing in the spring is very important because the soil pulverizes easily at that time and the loss of moisture is effectively checked. The best farmers disk the ground several times and harrow it once before planting, to pulverize, level, and compact the seed bed.

Fall plowing has a number of advantages, such as (1) longer and more complete exposure of the soil to the effects of frost, thus providing a better physical structure; (2) more time for the decay of vegetable matter, which increases the supply of available plant food; (3) closer connection between the plowed soil and that beneath; (4) exposure of injurious insects to birds or to unfavorable weather.

Fall-plowed land should not be disked or harrowed until early spring; otherwise it will become too compact, it will not catch the rain and snow water so well, and it is much more inclined to be blown than when left rough on the surface. Sod and stubble lands should be plowed in the fall unless they are so rolling as to wash badly or of such a nature as to be blown easily.

When corn follows corn, the land is usually plowed in the spring. Early spring plowing is preferable, as the soil has more time to settle, a larger amount of moisture is retained, and more plant food is made available.

**173. The importance of good seed.** Of two varieties or strains of corn growing side by side, one may produce a yield of ninety-five bushels, the other thirty-five bushels. The difference is due to something that one strain has and the other lacks. That something is the enlarged power to gather food from the soil and air and to utilize the sun's rays in organizing this food into stalk, leaf, and grain. It is this increased power which distinguishes an improved or pure-bred plant from a poor plant.

Since it requires the seed from only twelve or fifteen ears to plant an acre of corn, no reasonable pains should be spared to find the dozen ears that will produce the largest yield on every acre planted. An important consideration in selecting seed corn is to secure a variety or strain adapted to the local conditions of soil and climate. The results of careful experiments have shown that it is not safe to use seed from a widely different latitude, soil, or elevation.

**174. Regional varieties.** There are hundreds of varieties of corn, differing greatly in their adaptability to soils and climates. In the middle corn-belt region, embracing the states of Illinois,

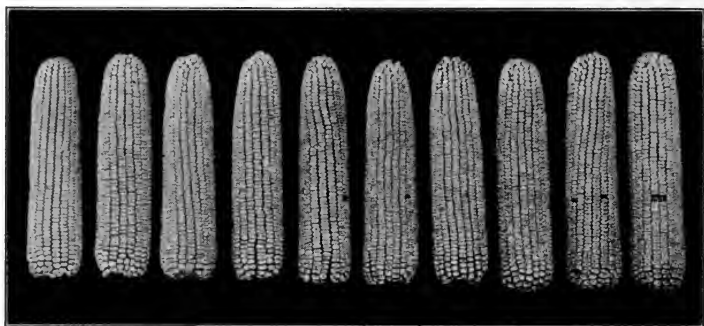
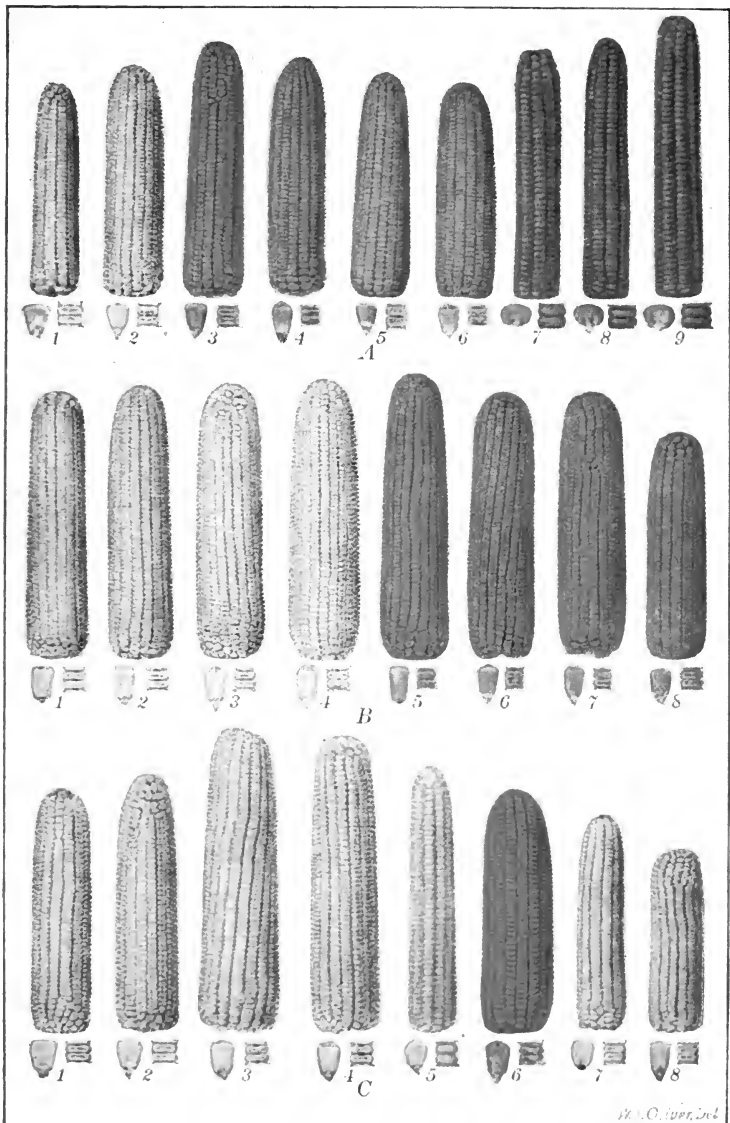

FIG. 61. Ten prize ears of Boone County White corn

Iowa, Indiana, Ohio, Missouri, eastern Kansas, and eastern Nebraska, the varieties most commonly grown are Reid's Yellow Dent, Leaming, Legal Tender, Boone County White (Fig. 61), Silvermine, Johnson County White, St. Charles White, Riley's Favorite, Clarage, Champion White Pearl, Hildreth's Yellow Dent, and Hiawatha Yellow Dent.

In the northern corn belt, including the states of Michigan, Wisconsin, Minnesota, the Dakotas, and northern Iowa and Illinois, the varieties most generally grown are Silver King, Pickett's Yellow Dent, Golden Eagle, Minnesota No. 13, Pride of the North, Wisconsin No. 7, Clark's Yellow Dent, Wimple's Yellow Dent (Fig. 62), Murdock, and some of the flint varieties





TYPES OF CORN EARS\*

For key see footnote on page 141

In the Southern states some farmers prefer a large-eared type which generally produces but one ear to the stalk; others like a variety with a strong tendency to produce two ears to a stalk; and still others prefer the type which under favorable conditions produces from two to five ears to the stalk. In the two kinds first mentioned are included varieties with red cobs and white grains, the popular "red cob" corn of the South. Among the large-eared varieties may be mentioned Huffman, Excelsior, Chisholm, McMackin's Gourd Seed, St. Charles White, Boone County White, Rockdale, Singleton, and Ferguson's Yellow Dent. Of the two-eared type, Lewis Prolific, Hickory King, and Neal's Paymaster are especially noteworthy. Among the prolifics, those of prominence are Cocke's, Albermarle, Whatley's, Mosby's, Hastings's, Marlboro, and Batt's. In the northern section of the cotton belt the prolific kinds of corn do well as silage crops on rich land, but they are not suited to poor land. Farther south they are used as a grain crop even on poor land.

The corn best adapted for New England is the 8-rowed and 12-rowed flint types. The most common and popular of these



FIG. 62. Wimple's Yellow Dent corn  
Prize ears exhibited by students in the  
South Dakota State College

The corn best adapted for New England is the 8-rowed and 12-rowed flint types. The most common and popular of these

The corn best adapted for New England is the 8-rowed and 12-rowed flint types. The most common and popular of these

\* Row *A* (Northern states): 1, Rustler's White Dent; 2, Silver King; 3, Pickett's Yellow Dent; 4, Golden Eagle; 5, Minnesota No. 13; 6, Pride of the North; 7, Longfellow; 8, Taylor's Improved Flint; 9, Davis's 8-rowed Flint.

Row *B* (Central states): 1, St. Charles White; 2, Silver Mine; 3, Boone County White; 4, Johnson County White; 5, Hildreth's Yellow Dent; 6, Leaming; 7, Reid's Yellow Dent; 8, Clarage.

Row *C* (Southern states): 1, Chisholm; 2, Commercial White; 3, Shaw's Improved; 4, Schieberle's White Dent; 5, Cocke's Prolific; 6, Ferguson's Yellow Dent; 7, Steinheimer's Marlboro; 8, Whatley's Prolific.

are Early Yellow Canada, Longfellow, King Philip, Waushakum, Triumph Yellow, and Early White Sanford. In Rhode Island a short, early, and distinctive white corn known as Rhode Island White Flint is generally grown. In the southern Connecticut valley some of the earlier dent types, like Leaming, Rustler White, and Brewer's Yellow, are grown in preference to the flint types.

**175. Selecting seed ears.** In selecting seed ears two primary problems are involved — the time and the method of making the



FIG. 63. Illinois high-school boys selecting seed corn  
"Corn judgment" should develop early in life

selection (Fig. 63). In the Northern states, such as the New England States, Iowa, Minnesota, Wisconsin, and the Dakotas, it is very necessary that the seed ears be picked before the general crop is mature enough to be harvested, in order to be able to choose ears from early-maturing plants and to be able to dry them thoroughly before freezing weather occurs. South of central Missouri early maturity is not so important a factor, and the seed may usually be left in the field until the crop is harvested, without its vitality or germinating power being injured. However, the practice of selecting the seed early in the fall from

the standing corn has so many advantages over picking the seed at the time the general crop is harvested, or later from the bin or crib, that it should be practiced by every corn grower.

Field selection affords an opportunity to study the stalk on which the ear grew and to observe the surrounding stand. The parent stalk should be vigorous and should bear the ear at a medium height. A well-developed ear, selected from a three-stalk hill, is more valuable for seed than an equally well-developed ear which grew in a one-stalk hill or where the surrounding stand was very thin. In selecting seed ears after they have been gathered, it is impossible to know whether their excellence is due to the exceptionally favorable conditions under which they grew or to their good breeding.

The common method of early fall selection is to go into the field with a sack, and then select the desired ears from the best stalks. In case seed ears are selected as the corn is harvested, a padded box should be attached to the side of the wagon to contain the ears chosen. The selection is usually too hastily done during harvesting time. In some cases seed ears are selected as the corn is being unloaded at the crib. Even this method has much to commend it over the common practice of selecting the seed from the bin or crib the following spring.

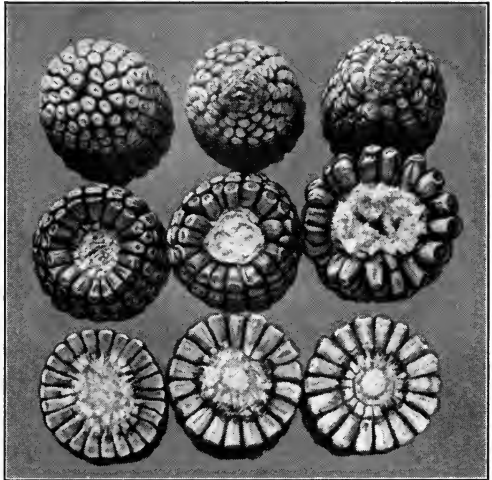

FIG. 64. Tips, butts, and middles

The left row shows a good ear, the middle row a fair ear, and the right a poor one. (Photograph from University of Missouri)

**176. Ear characteristics.** In choosing seed ears there are a number of characters or qualities, such as maturity and soundness, size and shape, character of kernel and germ (Figs. 64, 65, and 66), and uniformity of type, which should be carefully noted, since they indicate yielding capacity or are directly associated with quality or breed.

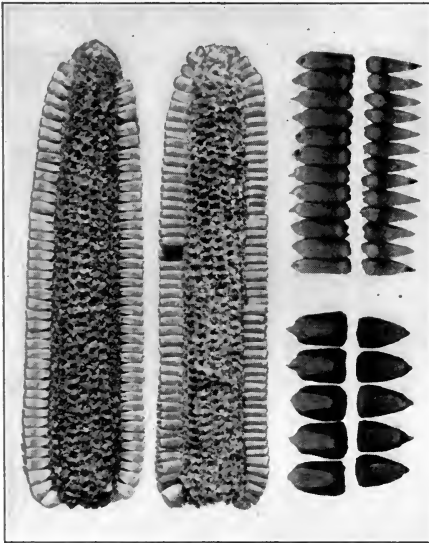

FIG. 65. More than surface observation is required in the selection of seed

The pointed grains, at the right, are from the left ear; the well-formed grains, at the left, are from the right ear

**177. Maturity and soundness.** Ears should be well matured, firm, dry, and of good weight for their size and condition. Immature corn should be avoided because (1) it will not keep well when stored; (2) it will not grow strongly when planted; and (3) it will not produce maximum yields when used as seed. There is not often any danger from lack of maturity in the corn regions south of central Illinois.

**178. Size and shape of ears.** The size of ear to choose will depend upon the climate and soil in which the corn is to be grown. Larger ears are chosen for regions having a long growing season and fertile soils, and smaller ears for northern climates or for infertile soils. A well-shaped ear should be nearly cylindrical, that is, should be of almost uniform diameter throughout, should have straight rows running directly from butt to tip, and should be full and strong in the middle portion. Such an ear will shell a large percentage of uniformly shaped kernels.



**179. Character of kernels and germs.** The most desirable depth of kernel depends on the climatic conditions under which it is to be grown. Ordinarily, deep kernels require a longer growing season than shallow kernels, and hence in the North and at high altitudes it is advisable to select shallower-kerneled corn than would be considered desirable for sections farther south. Deep kernels also require more moisture and a more fertile soil than do shallower kernels. Care must be taken, therefore, not to get the kernel too deep for the length of season, for the supply of moisture, or for the amount of plant food available. As a general rule, the grains should be keystone-shaped, since the grains of this shape fit closely together on the cobs, thus increasing the shelling quality of the corn and also providing room for the development of large germs.

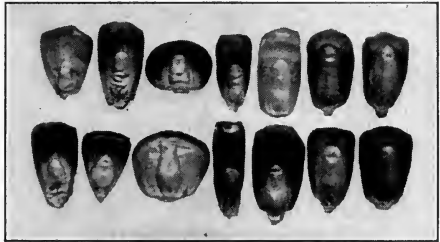

FIG. 66. Grains of good and poor form  
Which are the good grains?

The kernels should be about one sixth of an inch in thickness, or about six to the inch in the row (Fig. 65). The grains should be as nearly uniform in shape as possible, so that they will drop regularly from the planter and produce an even stand.

The germs should be long, wide, and thick. Approximately four fifths of the oil and one fifth of the protein of the kernel is found in the germ; therefore the larger the germs the more valuable the corn will be for feeding purposes. The results of experiments fail to show a direct relation between size of germ and yield of grain. Size of germ, however, does indicate the germinating power of the seed. Germs that are smooth, bright, and plump on the outside should be sought, while those that are shriveled, blistered, shrunken, moldy, or discolored should be discarded. The internal appearance of the germ should be fresh, oily, and of a light yellow color.

**180. Uniformity of type.** All of the ears selected should conform as nearly as possible to a fixed type. This will tend toward greater uniformity of drop in planting and also in the character of the resulting crop. When one is growing some special variety, the ears should conform quite closely to the

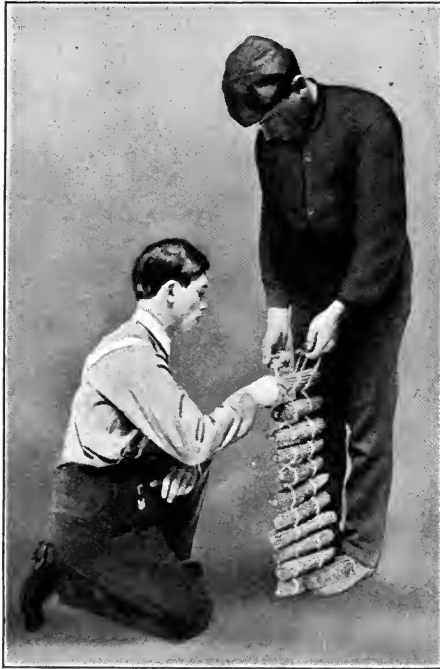

FIG. 67. The binder-twine seed hanger

standard characteristics of the variety. These detailed ear characteristics should be emphasized most carefully when making the final selection of seed ears.

**181. Storing seed corn.** When seed corn is gathered in the fall, it often contains as much as 40 or 50 per cent of moisture, while air-dried corn contains only from 10 to 14 per cent. If corn is frozen when it contains a large amount of water, the expanding water in the germ cells ruptures the cell walls, and the vitality of the seeds will be very seriously injured

and may be destroyed. Any dry, well-ventilated room or building which is mouse and rat proof is satisfactory for storage. Cellars or basements without furnace heat, open spaces over grain bins and near live stock, barbed-wire fences, windmills, and the sides of buildings, though sometimes used, are not desirable.

It is important that the ears be placed so that no two touch until they are thoroughly dried. A few practical methods are

(1) binder twine used as illustrated (Fig. 67); (2) the corn tree, made by driving tenpenny finishing nails in a timber at an angle and about two and one-half inches apart, the butts of the ears being placed on the nails; and (3) the Pittsburgh electric-weld two-by-four-inch-mesh fence cut so as to form a hanger. There are numerous hangers on the market costing from half a cent to a cent and a half an ear, but the homemade ones are as satisfactory and less expensive.

**182. Testing the germinating power of the seed.** Calculations show that only about 65 or 70 stalks of corn are secured for every 100 kernels

planted. While such factors as cold weather, wet soil, careless cultivation, and insect ravages are partly responsible for poor stands, the use of seed of poor vitality is the chief and altogether preventable cause. The germination test should be completed only a few weeks before planting time, in

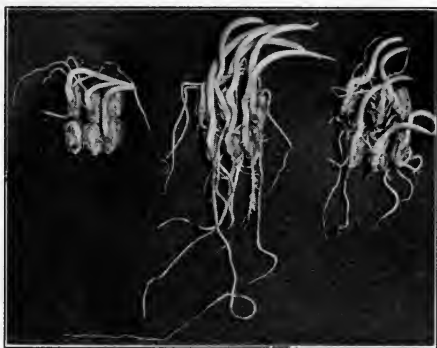

FIG. 68. Grains from different ears, showing differences in strength of growth

order that one may be certain that the vitality of the seed has not been injured by severe weather after the test was made. It is also easier to maintain a uniform temperature in the tester in the spring. Testing is of less importance south of the latitude of St. Louis, but it will pay to make the test wherever corn is planted.

A germination test culls out the dead or weak ears (Figs. 68, 69, and 70). The results of extensive investigations show that seed which germinates strongly in the tester gives a better stand and produces a larger yield than seed which does not show high or strong germinating power. When seed which showed 1 dead kernel out of every 6 kernels tested was planted alongside of seed

which gave perfect germination, the stand was decreased 10.8 per cent and the yield 6.2 bushels per acre. With seed showing 100 per cent germination but with 1 kernel out of every 6 tested showing weak germination, the stand was decreased 6 per cent and the yield 3.4 bushels per acre as compared with the results obtained from using seed that germinated completely and strongly.

**183. Grading seed corn.** It is important to have the kernels as uniform in size and shape as possible so that the planter will

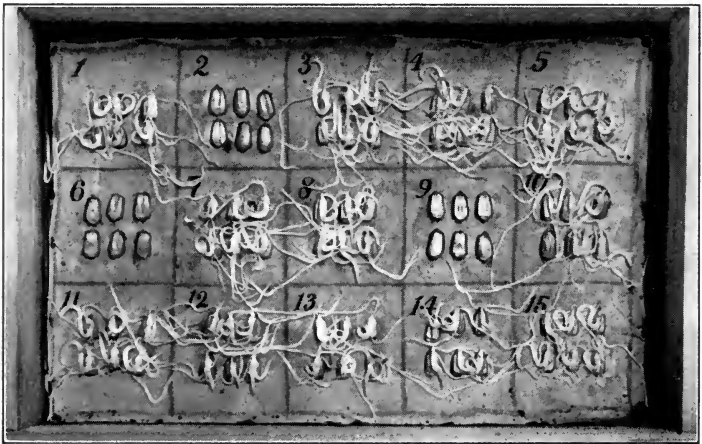

FIG. 69. A sand-box seed tester

drop them evenly. This is readily accomplished by running the corn through a corn grader or sorter. In shelling seed ears the butt and tip kernels should be discarded not because they will not produce good ears, but because these kernels are so irregular in size and shape that they cannot be planted successfully by machinery.

**184. Methods of planting.** Corn is planted either on the surface in rows, or in the bottom of a shallow furrow opened with a disk attachment on the planter, or in the bottom of a deep furrow opened with a lister. Surface planting is the common method in most of the corn-growing regions. Listing

is practiced principally on the friable, loamy soils of Kansas, Nebraska, Oklahoma, and western Missouri and Iowa.

When corn is surface planted it is either placed in check rows with the hills from 40 to 44 inches apart each way, and with from 2 to 4 kernels in each hill, or it is drilled, the rows being from 40 to 44 inches apart and the kernels placed from 8 to 20 inches apart in the row. In the Southern states the space between rows varies from 44 to 60 inches. Checked corn may be cultivated in two directions, and it is therefore easier to keep it clear of weeds than is the case with drilled corn. Under



FIG. 70. The "rag-doll" seed tester. (Photograph from Iowa State College)

similar growing conditions there seems to be little difference in yields from the two methods. Corn planted by listing with-stands drought better than surface-planted corn. In listed corn the grain is drilled, and then covered by the lister.

**185. Rate of planting.** Corn is planted thicker on fertile soils and in the North where the plants do not grow rank than on thin soils and in sections with the longest growing seasons. Throughout most of the corn belt, farmers usually plant either 2, 3, or 4 kernels per hill when the corn is check-rowed, or 1 grain every 13 to 16 inches if it is planted in drills. Corn planted for silage is often planted somewhat thicker than that grown for grain.

**186. The best time to plant.** The best time to plant corn varies with the locality, the season, and the soil. No definite calendar date can be set for any given area. Mid-season plantings are usually the most successful. The accompanying table shows the average planting-time range in various sections:

TIME OF PLANTING CORN IN CERTAIN REGIONS<sup>1</sup>

REGION	BEGINNING	GENERAL	ENDING	PLANTING PERIOD
				<i>Days</i>
Gulf states . . . . .	March 15	April 5	May 10	35
Central states (Virginia to Kansas) . . . . .	April 15	May 1	May 25	40
Northern states (New York to Minnesota) . . . . .	May 10	May 20	June 1	20

**187. How deep to plant.** Corn is planted only sufficiently deep to insure moisture for prompt germination. The proper depth will vary from one to two and one-half inches. The looser, drier, warmer, and more granular the soil and the warmer the air, the deeper the kernels are planted. Corn should be planted shallow early in the season, and the depth of planting should be increased as the season advances.

**188. Cultivation of corn.** The objects of cultivation are (1) to destroy weeds which are objectionable because they use plant food and moisture needed by the corn plants; (2) to conserve moisture by keeping on the surface a mulch, or blanket, of loose soil; (3) to provide more favorable conditions for the plant, thus making food available for the growing crop.

Surface-planted corn is ordinarily harrowed once or twice with a smoothing harrow before the corn germinates. This early cultivation stirs the surface, thus preventing the formation of a crust, and destroys the young weeds and grass as soon as they begin to grow. Harrowing should be repeated when the plants are a few inches high.

<sup>1</sup> Year Book of the United States Department of Agriculture, 1910, p. 491.

Corn should be cultivated frequently enough to keep the land free from weeds and to keep the surface soil loose. Under most conditions three or four such cultivations are sufficient, though occasionally as many as seven can be profitably given. A poor condition of the seed bed, the growth of weeds, and either frequent heavy rains or excessively dry weather will increase the number of cultivations required to grow a crop.

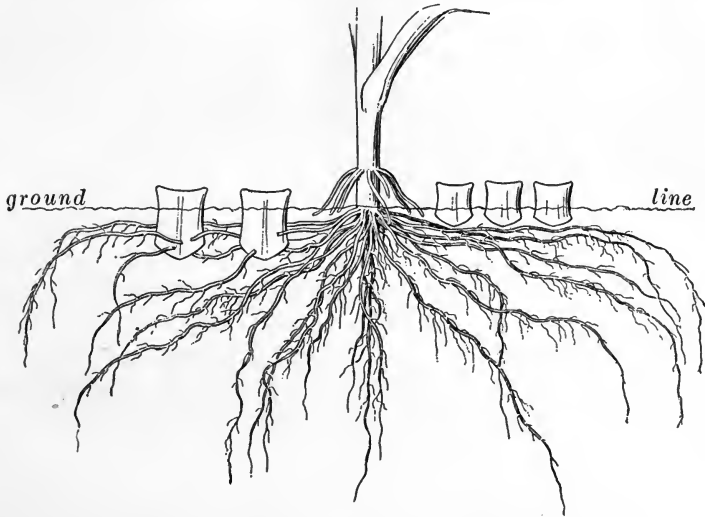

FIG. 71. Deep tillage destroys corn roots

At the first cultivation the ground may be stirred rather deeply and close to the plants without injury to the root system, but later cultivations should be shallow, and the shovels should be kept farther from the plants. The roots grow within a few inches of the surface and under most conditions extend from row to row (Fig. 71). Deep cultivation injures many of the feeding-roots and decreases the yield. Listed corn can be cultivated deeper without injury to the roots than can surface-planted corn. Experiments show that ridging the corn rather than leaving the ground almost level cuts off a larger number of roots, does not conserve moisture so well, and thus reduces the yield.

In listed corn the ridges are first leveled. When the corn is three or four inches tall, the dirt is thrown from the plants. By reversing the disks at the second cultivation, enough dirt can be worked into the furrows to cover the grass and weeds in the rows. Occasionally a spike-tooth harrow is used to smooth down the ridges, though this has a tendency to cover the corn. After the ridges are leveled, the cultivation should be the same as for surface-planted corn.

**189. Harvesting.** While experiments are constantly being made with machines for harvesting corn, no satisfactory solution of the problem has been found. Much of the corn in the principal corn states is harvested late in the fall from the standing stalks and the stalk fields are pastured during the winter months. This is a wasteful practice.

In parts of the South corn is sometimes harvested by stripping or topping. Stripping consists in removing the leaves for forage while they are green and in husking the ears later. In topping, the stalks are cut off just above the ears, for forage, and the ears are gathered by hand when they are fully mature.

In the Eastern and the Northern states nearly all the corn is either cut and shocked and field-cured, or it is cut and stored in the silo. When corn is to be field-cured, it is allowed to become almost mature before it is harvested. The corn is husked by hand and the stover fed whole, or the corn is husked by machinery and the stover shredded and stacked. On small areas and where labor is plentiful the crop is usually cut by hand. In the corn belt, machines which cut and bind the corn into bundles are commonly used.

In some corn regions it costs as much to harvest the crop as it does to grow it. A 3,000,000,000-bushel corn crop means an average of about 30 bushels for every person in the United States. To husk this corn requires the equivalent of a seven-and-a-half-hour day of labor for every man, woman, and child in the United States.



## QUESTIONS AND PROBLEMS

1. What is the relative importance of corn to other farm crops in your county? Is most of the corn produced in your county fed or shipped away?

2. To what points is corn shipped from your county? What use is made of that which is shipped?

3. Prepare an outline map of the world and shade the areas of chief corn production.

4. Why is it not a good plan to grow sweet corn or pop corn near field corn? If pop corn which has been grown near field corn is planted, what results may appear in the second year's crop of pop corn?

5. Under what conditions is fall plowing for corn better than spring plowing?

6. What varieties of corn have proved best for your locality?

7. Assuming an ordinary season, outline the procedure in the proper preparation of the soil for planting corn, and the proper cultivation of the crop until it matures.

8. What characteristics of a good seed ear should one have in mind when he goes into the field to select seed corn? Why is it not better to select seed corn at cribbing time, when the farmer may at a glance see a large number of ears from which to select?

9. Why is it important to test seed corn before planting? How may this best be done?

10. What is the average yield of corn per acre in your county? in the United States? What does your state experiment station regard as the possible average acre-yield in your state under a general good system of farming?

11. When corn is planted forty-four inches apart each way, how many hills are there to an acre?

12. With three stalks to the hill, and 85 per cent of a stand, how many stalks are there to an acre?

13. Assuming that each stalk bears an ear, and that each ear weighs twelve ounces, what is the yield per acre?

14. Assuming that each stalk bore an ear, and that the yield was twenty-five bushels more than the average of the United States, what was the average size of the ear? Have the students bring in an ear of this size to be compared with one that is considered to be of the average size.

15. Weigh the ear that is considered to be of average size for the community, ascertain the average yield in the community, and compute

the number of stalks per acre that were fruitful. What percentage of the stalks were barren?

16. Make a count in several cornfields and ascertain the per cent of stand, of fruitful stalks, of stalks bearing nubbin's, and of stalks bearing good ears.

### EXERCISES

1. **Judging corn.** In judging exhibits of corn the purpose should be to select the best seed. The score card is usually employed in beginning the study of ear characteristics. It calls attention in a logical order to the different ear characteristics and assigns a value to each. Scoring, however, is not an exact mathematical method to be followed mechanically. The score card should not be used in selecting or judging exhibits after the student has learned the characteristics of good seed and has developed a sound judgment. The agricultural colleges and the corn breeders' associations of the country have developed score cards planned to suit local conditions. The teacher should procure copies of the local score card. The score card in Appendix B applies in a general way to the conditions of the corn belt, and each student should score one or more ears of corn.

2. **Shelling qualities.** 1. Collect ears of various qualities as follows: not filled at the butt; not filled at the tip; partially filled along the cob; a cob which bore no grains; ears badly mixed in colors; very rough ears; smooth ears; tapering ears; cylindrical ears.

2. Compare the maturity of the above ears.

3. Shell a row of grains from a tapering ear and place the grains in order beside those of a row from a cylindrical ear. Compare the grains in depth, breadth, and thickness.

4. Weigh a tapering ear and a cylindrical ear of approximately the same length; then shell both, weigh the grains, and determine the percentage of weight which the grains make in each case.

5. Weigh all the grains from two rows of a tapering ear and from two rows of a cylindrical ear and compare.

3. **Pollination.** Cover an ear with a large paper bag before the ear has been pollinated. Dust plenty of pollen on the silks of a neighboring ear. Note how quickly the silks of the pollinated ear die and how long those of the unpollinated ear live and to what length they grow.

4. **Grading seed.** Examine a corn planter at the farm of a patron or at an implement store. Block the planter so that the grains may be

caught and counted as they are dropped. Drop a pint of grain shelled from the tips; a pint shelled from the butts; a pint shelled from the middle of the ear. What is the record of the number of grains dropped? Why are the butt and tip grains not used for machine planting? Why is it wise to grade seed corn before planting? How may this be done?

**5. An experiment in corn culture.** Arrange to have one of the pupils, or a farmer near the school, conduct the following tillage experiment for the school:

1. Have 4 plots of 4 rows each, 40 feet long.
2. Plot No. 1 should not be cultivated. The weeds should be allowed to grow throughout the year without being molested.
3. Plot No. 2 should be cultivated shallow as often as it is necessary to kill the weeds and to maintain a uniform mulch.
4. Plot No. 3 should be cultivated deep, and close to the corn rows, throughout the season.
5. In plot No. 4 keep the weeds killed by scraping the surface, but do not maintain any mulch. When matured, remove the corn from the ends of the rows so as to reduce the length of the rows to 31 feet. If the corn is check-rowed, the distance between the hills is 3 feet 6 inches. This will mean that each plot should be 4 rows wide and 9 hills long, and should contain 36 hills. This would be about one one-hundredth of an acre. Gather the corn from each plot and weigh from each plot separately. Multiply the result by 100 and divide by 70, and the answer will be the approximate number of bushels to the acre. What conclusions can you make as results from this experiment?

#### REFERENCES

- HUNT, THOS. F. Cereals in America. Orange Judd Company.  
MONTGOMERY, E. G. The Corn Crops. The Macmillan Company.  
SARGENT, F. L. Corn Plants. Houghton Mifflin Company.  
How to Grow an Acre of Corn, *Farmers' Bulletin 537*, United States Department of Agriculture.  
Corn Cultivation, *Farmers' Bulletin 414*, United States Department of Agriculture.  
Seed Corn, *Farmers' Bulletin 415*, United States Department of Agriculture.



## CHAPTER XIV

### THE SMALL GRAINS

What was the cause of the greater fruitfulness of the land in ancient times? Was it because in those days the land was cultivated by the hands of generals, and the earth, delighted to be plowed with a share adorned with laurels and by a plowman who had been honored with a triumph, or was it because these men plowed their fields with the same diligence with which they pitched their camps, and sowed their grain with the same care with which they formed their armies for battle? — PLINY

#### I. WHEAT

**190. When wheat-growing began.** Man was still a cave dweller when he first gathered the wild wheat berries and ground them into flour with his teeth. Centuries later the wheat was stored for future use and then ground in a hollow stone with another stone (Fig. 72), as it was rocked or rolled back and forth. The flour, black but nutritious, was mixed with water and salt and baked in the ashes of the open fire.



FIG. 72. Stone bowl and pestle — an ancient flour mill

Later, the plow took the place of the crooked stick in the cultivation of the soil. The sickle was followed by the cradle and the cradle by the reaper (Fig. 2); then came the self-binder, followed by the header. Lastly there came the combined harvester and thresher, which harvests and threshes forty acres or more a day and deposits the grain in sacks ready for the mills.

**191. Classes of wheat.** There are eight types of wheat (Fig. 73): Common Wheat, Club Wheat, Durum, Speltz, Emmer, Einkorn, Polish, and Poulard. About 90 per cent of the wheat grown in the United States is of the common type. Club and durum wheats and emmer are important in a few localities. The other kinds are not grown in this country, except for experimental purposes.

Common wheat is divided into two great classes known as winter wheat and spring wheat. Winter wheat is sown in the fall and harvested late in the following spring or in early summer. Spring wheat is sown in the spring and harvested the same year, usually about a month or six weeks later than winter wheat. Fully 70 per cent of the

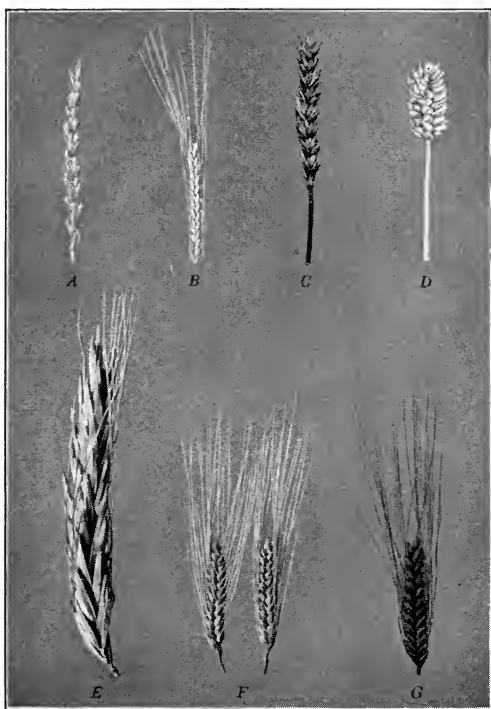

FIG. 73. Types of wheat

*A*, Speltz; *B*, Einkorn; *C*, Common Fultz; *D*, Club;  
*E*, Polish; *F*, Durum; *G*, Black Winter Emmer

entire wheat crop grown in the United States is winter wheat.

Winter wheat possesses so many advantages over spring wheat that it is grown wherever it will withstand the winter. Winter wheat yields better, because it matures earlier and therefore more often escapes the rust and other diseases, as well as the ravages of insect pests, the injury from hot weather, drought,



a Bluestem variety originated at the Minnesota Experiment Station; Minnesota No. 163, a Fife variety originated at the same station; and North Dakota No. 66, a Fife variety originated at the North Dakota Experiment Station. These varieties, when grown in this area, produce the best milling wheat in the United States. A third class, the so-called velvet-chaff wheat, is grown to a considerable extent in central Minnesota and central South Dakota. This wheat is a bearded Fife with smooth, white chaff, noted for earliness, high yield, and weight per bushel. It



FIG. 75. Wheat in the shock (Minnesota)

sells for less than other varieties because of its slightly inferior milling qualities. The durum wheat of the United States is also produced in this district, principally in northeastern South Dakota and in southeastern North Dakota. Durum wheat was first grown in this area in 1899-1900, and the annual production is now about 40,000,000 bushels. It yields from 15 to 100 per cent more than common spring wheat in this area, and is noted chiefly for its resistance to drought and rust.

**193. Hard-winter-wheat district.** The hard-winter-wheat district borders the hard-spring-wheat district on the west, the south, and the southeast, the two somewhat overlapping. A line

approximately dividing the two districts would pass through Forsythe (Montana), northeastern Wyoming, northern Nebraska, Sioux City (Iowa), and La Crosse (Wisconsin).

The principal hard-winter-wheat-producing states of this area are Kansas, Nebraska, Montana, and portions of Oklahoma, Colorado, and Iowa. The varieties grown are Kharkof and Turkey, or improved strains of these varieties. They comprise the hardiest varieties of winter wheat known, and are therefore grown the farthest north.

**194. Soft- and semihard- winter-wheat district.** The area producing semihard and soft winter wheat lies south and east of that producing hard winter wheat and comprises the states of Illinois, Indiana, Ohio, Pennsylvania, Kentucky, Tennessee, Missouri, and the eastern parts of Oklahoma, Kansas, and Nebraska. The annual rainfall varies from 35 to 45 inches. The hard-wheat-producing area of Kansas and Nebraska has a rainfall varying from 17 inches on the western border to a little over 30 inches at the eastern border. Features of this area are the scarcity of rainfall during the summer months and the relatively high temperatures which prevail. This hastens the maturity of the grain, producing a kernel very hard and high in protein. The opposite conditions which prevail in the soft-wheat area produces a soft grain, high in starch and lower in protein.

**195. Pacific coast district.** The wheat of the Pacific coast region is very plump, starchy, and soft. The annual production is small and appears to be decreasing. The main producing area is in California.

The rainfall of this area occurs entirely in the winter season. The rainless summers permit the wheat, after it is ripe, to stand in the field with little danger of loss. It is this fact which allows the use of a machine that harvests and threshes the crop at one operation, leaving the sacked grain in windrows in much the same manner as the ordinary binder leaves the bundles. This method of harvesting and threshing makes it necessary to grow varieties which do not lodge or shatter. Both these qualities are



possessed by the short-strawed and compact heads of the club varieties which are commonly used. Australian Club and Little Club are common in this area.

**196. Palouse district.** The Palouse district of Washington and Oregon is in many respects similar to the Pacific coast district. The rainfall is much less and the wheat is somewhat harder. The varieties grown, however, are often the same as those of the Pacific coast, so that the difference is less than would otherwise be the case. The hard Turkey wheat of the Plains is being introduced to some extent, and appears to be superior to the more common varieties.

**197. Intermountain district.** The area between the Rocky Mountains and the Pacific coast grows a small amount of wheat in various localities. Nearly all of it is produced by dry farming. Very little spring wheat is grown. The most prominent varieties are Washington, Bluestem, Lofthouse, Koffoid, and Turkey.

**198. Atlantic coast district.** The amount of wheat produced on the Atlantic coast is very small compared with the total for the United States. This wheat is important, however, in supplying the local demand. It differs from the soft- or semihard-winter-wheat district, since the higher precipitation produces wheat that is softer. The principal varieties grown are Purple Straw, Lancaster, and Fultz.

**199. Time of plowing.** Wheat requires a finely pulverized, compact seed bed. Therefore it is very important to plow considerably in advance of the time of seeding, in order to allow the soil to settle and to favor the accumulation of available plant food near the surface where the young wheat plants may easily reach it. To prevent the loss of moisture by evaporation and to keep the weeds from using the moisture and plant food the land must be disked and harrowed often enough to maintain a surface mulch.

**200. Depth of plowing.** The cost of plowing increases with the depth. It is, therefore, important to know just what depth of plowing will give the most profitable yields. The deeper the soil and the drier the climate, the deeper the land should be

plowed. As a rule, the increase in yield gained from plowing more than eight inches deep in any soil or climate does not pay for the extra cost, and it is probably not advisable to plow to this depth every year. The compact soils of the humid belt should not be plowed deeper, perhaps, than five or six inches on the average. If wheat is rotated with other crops and the land is plowed



FIG. 76. How the yield may be increased by timely plowing

deep for the crop which precedes wheat, the depth of plowing for the wheat may be less than when no rotation is practiced.

If plowing must be done immediately before seeding, it should be shallow, or else the ground will be too loose for good results. Deeply plowed soil should always have ample time to settle before the crop is sown.

**201. Value of timely plowing.** The importance of timely plowing at the proper depth is well shown (Fig. 76) by an experiment conducted at the Kansas State Agricultural College.<sup>1</sup> Land

<sup>1</sup> *Bulletin 176*, Kansas Agricultural Experiment Station.

was prepared for wheat in eleven different ways. In each case the seed, manner of seeding, and kind of ground was the same. The only difference was in the time and method of preparing the ground. The results are given in the following statement :

*No. 1.* The ground was disked only, before planting. The average cost of preparing the ground was \$2.07 per acre, and the yield was 6.63 bushels, which at the market price when threshed was worth \$5.71, leaving a balance of only \$3.64 per acre to pay for the cost of seed, seeding, harvesting, and marketing and to pay a profit to the grower.

*No. 2.* The ground was plowed 3 inches deep (too shallow) September 15 (too late for best results). The average yield in this test was 13.24 bushels, worth \$11.18, and the cost of preparation was \$2.83, leaving a balance of \$8.35 per acre with which to meet expenses and pay a profit.

*No. 3.* Ground was plowed 7 inches deep in September. A yield of 14.15 bushels, worth \$11.93, was obtained. The cost of plowing and preparation of the ground was estimated at \$3.33, leaving a balance of \$8.60.

*No. 4.* Land was double disked July 15 to kill weeds and prevent evaporation of moisture, and plowed 3 inches deep September 15. The average yield was 19.71 bushels, worth \$16.30. The cost of preparing the ground was \$3.93, leaving a balance of \$12.37.

*No. 5.* August 15 the plot for this test was plowed 7 inches deep and worked afterwards sufficiently to kill weeds and conserve moisture. The cost of preparation was \$4, the yield 22.19 bushels, worth \$20.34, leaving a balance of \$16.34.

*No. 6.* August 15 land was plowed 7 inches deep, but was not worked until September 15. The cost of preparation was \$3.33, the average yield 20.48 bushels, valued at \$16.98, leaving a balance of \$13.65. As the preparation of the seed bed in this test was identical with No. 5, except that the ground was not worked for a month after plowing, the early disking was worth \$3.36 per acre.

*No. 7.* July 15 (right time) land plowed 3 inches deep (too shallow) produced an average yield of 20.17 bushels, worth \$17.10. The cost of preparation was \$4.85, leaving a balance of \$12.25 per acre.

*No. 8.* In this test the ground was double disked July 15 and then, August 15, plowed 7 inches deep. The cost of preparation was \$4.93, and the yield, 23.4 bushels, was worth \$19.20 at market price, leaving \$14.30 to pay other expenses.

*No. 9.* July 15 this plot was listed 5 inches deep, and the ridges split August 15. The average yield for the three years was 22.9 bushels, worth \$18.65. The cost of preparation was \$3.92, leaving a balance of \$14.73.

*No. 10.* In this test the land was listed 5 inches deep on July 15 and was worked down level the following month to firm the seed bed and prevent loss of moisture. The average yield was 22.77 bushels, worth \$18.58. The cost of preparation was \$4.05, leaving a balance of \$14.53.

*No. 11.* Land plowed 7 inches deep (right depth) July 15 (right time) produced an average yield of 27.11 bushels per acre, worth \$22.22. The cost of preparation was \$5.35, leaving \$16.87, the largest balance of any in the test.

**202. Preparing land for wheat when grown in rotation with other crops.** It has been found that when wheat is grown in rotation with other crops, the yield is not only better but is often obtained at less expense. This is shown by an experiment<sup>1</sup> in preparing ground for wheat that was used for oats in 1912 and for corn in 1911. This ground was plowed 7 inches deep for the corn crop and 6 inches deep for the oats. After the oats were harvested, the ground was prepared for wheat in five different ways with the following results: Three plots were plowed in July, 3 inches, 7 inches, and 12 inches deep, respectively. All three of these plots produced practically the same yields — 44.08 bushels for the 3-inch plowing, 44.66 bushels for the 7-inch plowing, and 44 bushels for the 12-inch plowing. The cost of preparing the ground, however, was quite different — \$4.35 for the 3-inch plowing, \$4.85 for the 7-inch plowing, and \$8.10 for the 12-inch plowing. This experiment shows that where wheat is rotated deep with other crops and the ground is well prepared for them, deep plowing is not so essential as when the wheat is grown continuously upon the same land.

<sup>1</sup> *Bulletin 176*, Kansas Agricultural Experiment Station.

**203. Screened and graded seed best to sow.** Wheat should be screened and graded before seeding to remove all weed seeds and small shrunken kernels. The young plant must depend upon the food stored in the seed until its roots are established. If small shrunken kernels be sown, the food supply may be insufficient, especially if the season is unfavorable. The young plants may die when those from better seed survive and produce a good crop. In grading, the aim should always be to retain the heaviest seed rather than merely the largest.

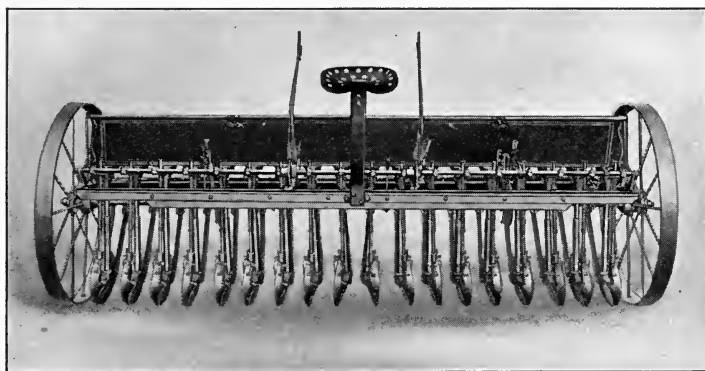

FIG. 77. A wheat drill

**204. Seed with a drill.** Wheat may be sown broadcast and covered with a harrow or it may be sown with a drill. Experience has shown that seeding with a drill (Fig. 77) is better than sowing broadcast, because about one third less seed is required for the same thickness of stand, because the grain is distributed more evenly and at a more uniform depth, causing the seed to germinate more evenly and more promptly, and because the plants go through the winter in better condition.

**205. When to sow.** The time of seeding is one of the important points in growing wheat. A safe rule to follow with spring wheat is to seed as early in the spring as the conditions of the ground will permit. The best time to seed winter wheat is not so easily determined. It is usually necessary to sow early

enough to produce a considerable growth before winter sets in, to avoid winter killing. But where the Hessian fly is prevalent, it is necessary to seed late enough to avoid damage from this source. In subhumid regions, the frequent lack of seasonal rains gives the farmer less choice in the time of seeding. The usual plan in these regions is to seed early if rains occur. Otherwise, the grain is sown late, sometimes so late that it does not come up before winter sets in. Early seeding as a safeguard against winter killing appears to be less essential there than in



© Underwood & Underwood

FIG. 78. Harvesting wheat in Palestine

humid regions. A heavy growth in the fall uses the reserve moisture in the soil and may result in a short crop the following season.

**206. How much seed to sow to the acre.** From 3 to 6 pecks of seed are usually sown to an acre. Winter wheat is not usually sown as thickly as spring wheat. The rate is less on arid lands than on humid, and on poor soils than on rich

soils. One bushel of Turkey wheat contains from 800,000 to 1,000,000 kernels. If all are viable, 1 bushel of wheat per acre will produce about 20 plants to each square foot.

**207. The depth to sow.** Wheat is usually sown from one to three inches deep, according to the surface conditions of the soil. As a rule, planting from one to two inches deep gives the best results if the soil is sufficiently moist at that depth to insure germination. The depth of seeding does not affect the depth to which the roots of wheat penetrate, as is sometimes thought. The aim, therefore, should be to seed at that depth which will result in the quickest germination and most rapid growth.

**208. Pasturing wheat.** Farmers in the winter-wheat district sometimes make a practice of pasturing wheat in the fall and sometimes during the winter and early spring. If this is judiciously done, much valuable feed may be saved by fall pasturing,



FIG. 79. Threshing wheat in Japan and in the United States

without material injury to the grain. Spring pasturing is seldom advisable, and should be avoided when the ground is soft. To obtain the benefit of the fall pasture one sometimes seeds so early that his wheat is injured by the Hessian fly.

**209. Harvesting.** Wheat was probably first harvested by picking the heads by hand or by pulling the entire plant and removing the heads with a comb or hackle (Figs. 78 and 79). Crude stone instruments were devised to aid in pulling or break-



FIG. 80. McCormick, the inventor of the reaping machine

Cyrus Hall McCormick, 1809–1884, was a Virginia farmer and blacksmith. He invented a grain cradle at the age of fifteen and the reaper at the age of twenty-two. His father, Robert McCormick, invented a clover huller, a hemp-brake, and a threshing machine, and tried to invent a reaper but failed. At the close of the first trial of the new reaper, in which young McCormick was praised as well as jeered at, the father said, "Your reaper is a success. It makes me feel proud to have a son do what I failed to do"

ing the straw, and these were later displaced by the sickle. The next development was the scythe, and then the cradle, which appears to have been first used by the Romans (Figs. 1*a* and 1*b*). These implements were the only ones used for harvesting grain until after 1840. The rapid increase in the wheat acreage since the beginning of the nineteenth century is largely due to the invention of the reaping machine (Fig. 2) by McCormick (Fig. 80), the self-binder by Appleby and others, and the headers and the combination harvesters (Fig. 3) and threshers (Fig. 81) which are now so extensively used.

In many countries grain is still harvested with the sickle and threshed with the flail. Most of the countries which use reapers and threshers depend upon America to supply them with machines. America excels in inventing and manufacturing farm machinery.



## II. OATS

**210. Introduction of oats.** The cultivated type of oats (Fig. 82) is of recent origin in comparison with wheat and barley, and probably came from east-central Europe or western Asia. Oats are also used extensively in northern latitudes as food for man. This grain was introduced into the United States by the earliest colonists, and its cultivation soon became very common.

**211. Regions of growth.** The United States, with approximately 950,000,000 bushels, or nearly one fourth the total crop of the world, ranks first in oat production. About one tenth of

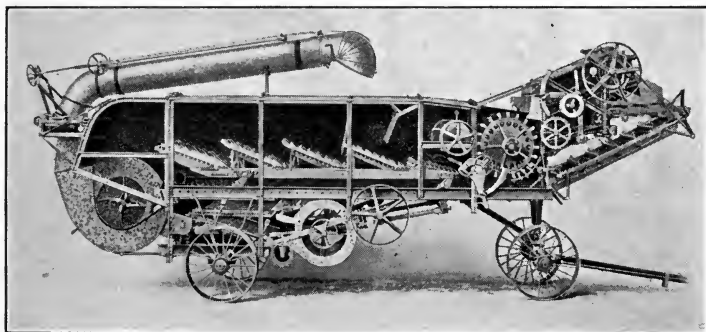

FIG. 81. A threshing machine

The machine is shown in the diagram with one side covering removed so as to show the cylinder and "shakers" by means of which the grain and straw are separated

the entire oat crop of the world is produced in the central upper Mississippi Valley in the four states, Iowa, Illinois, Wisconsin, and Minnesota. Oats are grown quite extensively in such countries as Sweden, Norway, Denmark, and the United Kingdom, but because of their limited areas, they rank below Russia, Germany, France, and Canada in total production. As in the case of wheat, there are two types of oats, winter and spring. The winter type is grown almost altogether in the Southern states and is well adapted to the climate of that region. Spring oats, the principal type of the world, are best adapted to a cool, moist climate.

**212. Cultivation.** The soil requirements for oats are not so exacting as for several other of the small grains, notably wheat and barley; consequently a fair crop may be produced on almost any soil of average fertility.

The most approved practice is to sow oats as early in the spring as possible. The surface soil should be mellow and fine, but the subsoil should be firm. Probably 90 per cent of the

oats grown in the corn belt are seeded on corn-stalk land without plowing, the surface being double-disked and harrowed once or twice.

Oats are usually sown broadcast, but the results of repeated tests show that seeding with a drill gives larger yields because all of the seed is covered to a uniform depth and prompt germination is insured. The rate of seeding is usually between two and four bushels per acre.

**213. Harvesting.** The crop is usually harvested when the grain is in the hard-dough stage, or at



FIG. 82. Two types of oat heads

the time when the heads are yellowing rapidly. The grain is shocked as soon as possible after being cut, in order to favor slow curing, which increases the palatability of both the grain and the straw. The crop is usually threshed directly from the shock, though a better quality of grain may be obtained by stacking the oats, and threshing after they have gone through the "sweat" in the stack (Fig. 83).

## III. BARLEY

**214. Where barley grows.** Barley is among the oldest of our cultivated plants. It was probably grown at as early a date as was wheat, and for many thousands of years before oats or rye. It is believed that barley was first grown in southwestern Asia. About one fourth of the barley of the world is produced in Russia. The United States ranks second, and Germany third, in barley production. Nearly 90 per cent of the barley of the United States is produced in eight states, California ranking



FIG. 83. Stacks of oats

The practice of stacking wheat and oats to await the coming of the threshing machine was formerly much more common than now

first, Minnesota second, and Wisconsin third. This crop has a wider range than either wheat or oats, yet it is more exacting than either of these cereals in its soil needs. It is grown most extensively in the north temperate zone and gives the best results there.

**215. Types of barley.** There are two generally recognized types of barley—the six-rowed and the two-rowed types. The six-rowed type is grown almost exclusively in the corn belt as a partial substitute for oats in the rotation and as a feed, while a little further to the north and west the two-rowed type seems to give the best results.

**216. Growth and use.** Barley is sown and harvested in very much the same manner as oats except that the land is usually plowed for barley. Two bushels of seed to the acre is the usual rate of seeding. The seed should be graded carefully and sown with a drill, in order that the grain may ripen uniformly and be of the best quality. The cap sheaves are threshed separately from the rest of the bundles, for the presence of a small per cent of weather-stained kernels may cause a cut of from three to six cents a bushel in the price of the grain.

As feed, barley may be said to stand between oats and corn, being somewhat less valuable than corn for fattening purposes and not quite equal to oats for growing animals, but superior to oats for fattening and superior to corn for the growing animal.

#### IV. RYE

**217. Cultivation and use.** Rye is a crop of minor importance in the United States, only one bushel of rye being grown for every twenty bushels of wheat. Rye, however, stands next to wheat as a bread grain. In the world's production — about one half as many bushels of rye as of wheat are grown. In some important countries, for example Germany and Austria, it is the principal cereal, and more than twice as much rye as wheat is produced.

Most of the rye produced in the United States is grown in Pennsylvania, Michigan, Wisconsin, New York, and Minnesota. It is more hardy than wheat, and this is one of the principal reasons for growing the crop. The methods of culture for rye are the same as for wheat. In most countries rye is used to some extent for bread, and in some countries it is a staple article of diet. It is extensively used in the manufacture of fermented liquors and as a food for stock. When ground and fed in quantities not exceeding two or three pounds daily in connection with oats or barley, it makes a most satisfactory horse feed. For hogs it is the equal of barley. When fed to milk cows, rye is believed to impart a bitter flavor to the milk.

## V. RICE

**218. Where grown.** Rice is the principal food of more than half the people of the world. Where the population is most dense and the struggle for existence most intense, rice, supplemented by fish, beans, and peas, has become man's chief reliance.

The principal rice-producing countries of the world are China, Japan, India, and parts of Africa. Rice was introduced into the



FIG. 84. Harrowing rice ground in the Philippines

In tropical countries rice ground is cultivated under water, the water buffalo being used as a work animal

United States at Charleston, South Carolina, in 1694. The production of rice in the United States is confined to the South Atlantic and the Gulf states. We produce less rice than we consume, although there is ample land well adapted to this crop in the Gulf states.

**219. Cultivation.** Rice is chiefly grown on low, level land under irrigation (Fig. 84), although there are varieties which can be grown on upland without irrigation. The surface of each rice

field must be almost perfectly level, so that the water, when the field is flooded, may stand at a uniform height over all its parts. Usually each field is surrounded by a levee and canal for water control. The fields vary in size from 1 or 2 acres along the Mississippi River to from 60 to 80 acres on the level prairies of southeastern Louisiana. In the United States the land is plowed, disked, and harrowed as a preparation for seeding. Rice seed should be sown with a drill at the rate of from  $1\frac{1}{2}$  to 3 bushels an acre sometime during the months of March, April, or May. Unless water is needed to germinate the seed, the land is not



FIG. 85. Harvesting rice in Arkansas

flooded until the plants are from 6 to 8 inches high, when the surface of the field is covered with water to a depth of from 3 to 6 inches, and this depth is maintained until the crop is almost mature. In the Orient the plants are started in germinating beds, then transplanted to the fields when they are about six inches high.

**220. Harvesting.** Harvesting is done by machinery if the ground has become firm enough to bear the reaper (Fig. 85). Rice is cured, shocked, and threshed in much the same way as wheat. The threshed grain, or rough rice, as it is usually called, is sent to a mill, where the rough husks and closely fitting chaff, or cuticles, are removed and the grain is polished ready for the market. A fair yield of rough rice is from 30 to 40 bushels an acre.

## QUESTIONS AND PROBLEMS

1. Upon an outline map of the United States shade the chief wheat-growing, oat-growing, barley-growing, rye-growing, and rice-growing regions, and indicate which kinds of wheat are most grown in the different wheat regions.

2. How should the seed bed be prepared for wheat?

3. Suppose each one of five farmers has a forty-acre field of wheat and that each one of the five secures a yield in proportion to a different one of the tests shown in Fig. 76. At the present price of wheat in your locality, calculate (1) what each man would receive from his forty acres of wheat; (2) how much more or less this is than the average amount received by the five; (3) how much less this is than the amount received by the one receiving most.

4. How may wheat be used most profitably in rotation with other crops?

5. What factors should be taken into account in selecting good seed wheat?

6. Discuss the sowing of wheat as to manner; time; amount of seed; depth to plant the seed.

7. What relation is there between the amount of grain a man may now grow and the changes which have taken place in the past century in the manner of harvesting wheat?

8. Compare oats and wheat in productivity; in yield; in commercial value; in feeding value.

9. Discuss briefly (1) the planting, (2) the preparation of the seed bed, and (3) the sowing and harvesting of oats.

10. What is the relative importance of barley as a cereal crop?

11. Compare the sowing and harvesting of barley with the sowing and harvesting of oats.

12. Compare the production and importance of rye in this country with the production and importance of wheat.

13. What are the principal uses to which rye is put in this country? in Europe?

14. How is rice planted? cultivated? harvested?

15. How is rice grown in the oriental countries?

16. What is the quantity and value of the world's production of rice? What peoples depend chiefly upon rice for their food?

## EXERCISES

**1. Testing different grades of seeds.** Obtain a sample of good wheat and divide into lots according to the size of the seed. Select for the first lot the largest, plumpest, heaviest kernels; for the second lot, those of medium size and plumpness; and for the third, the small, shrunken kernels. Plant each lot separately under similar conditions as to soil, depth, and rate. Record the time of coming up and the size of plants at the end of ten and thirty days respectively. If a winter variety, note any differences in winter killing. Winter oats, barley, and rye may also be sown in the same manner, in order to get survival effect regardless of the severity of weather conditions.

**2. Selecting seed.** Select from fifty to one hundred heads from a field of standing wheat, or from the shock or stack, or from samples previously collected and kept for this purpose. Obtain as many types as possible. Thresh each separately and place in envelopes. Count and weigh, to determine which heads are most productive. Count out an equal number of kernels of each, and seed those from each head in a row by themselves. Note winter survival, time of coming up, heading, ripening, and yield and quality of grain. Would it be possible to improve the wheat yield by increasing and propagating any one of these strains?

## REFERENCES

- BAILEY, L. H. *Cyclopedia of American Agriculture*, Vol. II. The Macmillan Company.
- DONDLINGER, P. T. *The Book of Wheat*. Orange Judd Company.
- HUNT, T. F. *Cereals in America*. Orange Judd Company.
- HUNT and BURKETT. *Farm Crops*. Orange Judd Company.
- LIVINGSTON, G. *Field Crop Production*. The Macmillan Company.
- WILSON and WARBURTON. *Field Crops*. Webb Publishing Company.
- Barley Culture in the Southern States, *Farmers' Bulletin 427*, United States Department of Agriculture.
- Culture of Winter Wheat in the Eastern United States, *Farmers' Bulletin 596*, United States Department of Agriculture.
- Oats, Growing the Crop, *Farmers' Bulletin 424*, United States Department of Agriculture.
- Rice Culture, *Farmers' Bulletin 417*, United States Department of Agriculture.
- Winter Oats for the South, *Farmers' Bulletin 436*, United States Department of Agriculture.





## CHAPTER XV

### FIBER CROPS

**221. Kinds of fiber crops.** Fibers are used chiefly for the manufacture of cloth, and are animal (such as wool) and vegetable (such as cotton, hemp, and flax). By far the more important are the vegetable fibers, and chief in importance among these is cotton.

#### I. COTTON

**222. The uses of cotton.** Cotton is adapted to a wide range of uses. Of all the vegetable fibers from which clothing is manufactured, most civilized peoples use cotton clothing, and their parlors, dining rooms, and bedrooms are furnished largely with cotton fabrics. The coarsest sailcloths and tarpaulins are made of cotton. Collodion and allied products used for photographic films and many useful household articles are made from cotton. Guncotton, a high explosive, is prepared by treating cotton with nitric acid. Absorbent cotton, an invaluable adjunct to modern surgery, is prepared by removing from the fiber the substance that makes the cell wall repellent to water. Cottonseed is used to some extent by farmers as feed for live stock and as a fertilizer. The oil is extracted from the seed and refined. The better grades are used as table oil (sometimes as an adulterant of olive oil); for preserving sardines or other canned goods; for cooking (either alone or compounded with animal fats and other products). The lower grades of oil are used in the manufacture

of soap and washing-powder. Cottonseed meal is used extensively as a feed for farm stock and is exported to Europe in large quantities for this purpose. It is also used extensively as a fertilizer.

**223. Growth of the cotton industry.** Cotton has been used from ancient times and is probably a native of both India and America. Its preëminent position, however, as a Southern farm crop has come since the invention of the spinning wheel in 1769 and the cotton gin in 1792. The most rapid development of the cotton industry has been during the past quarter century.

The total cotton crop of the world is nearly 11,000,000,000 pounds of clean fiber, of which the southern United States produces about 7,000,000,000 pounds, India about 1,500,000,000 pounds, and Egypt 250,000,000 pounds. We export more than half of our crop. More money is brought into the United States in payment for cotton and cottonseed cake and oil than for any other single farm product or any other class of products exported.

**224. Kinds of cotton and their value.** The cotton plant is a native of the tropics and in regions of no frost is perennial. Botanically it belongs to the mallow family, and there are four species<sup>1</sup> recognized. Tree cotton, so called because it grows to the size of a small tree, is not cultivated. Sea-island cotton has a yellow bloom, a small boll, a tall stalk, and a three-lobed leaf. It is grown near the Atlantic coast in Florida, Georgia, and South Carolina. It has the longest, finest, and strongest fiber of all cottons, and brings twice the price of the average upland cotton. Only a small percentage of the crop is of this species. Egyptian cotton is probably a native of Peru and is grown especially in Egypt, where it produces a very desirable quality of fiber not attainable elsewhere.

**225. The cotton plant.** The stem of the cotton plant is somewhat woody, and in good soil the plant attains a height of from 5 to 6 feet. The branching habit of the stem varies. In some

<sup>1</sup> The four well-known species of cotton are *Gossypium arboreum*, tree cotton; *Gossypium Barbadense*, sea-island cotton; *Gossypium Peruvianum*, Egyptian cotton; and *Gossypium hirsutum*, common cotton.

varieties the fruit-bearing branches are short, giving the plant the appearance of having the fruit clustered about the main stem. Other varieties have branches of such length as to give the pyramidal or oval form to the general outline of the entire plant when it is grown. Between these extremes there are an endless number of intermediate types. The method of branching is of considerable importance in selecting and breeding cotton.



FIG. 86. Young cotton growing on good soil  
Well-tilled deep loam is the best soil for the cotton crop

The cotton plant has a taproot which penetrates to a greater depth than do the roots of most farm crops ; hence its resistance to drought. Lateral roots penetrate every portion of the surface soil before the plant matures.

The leaves are from 3 to 5 inches broad and are generally 5-lobed (Fig. 86). Varieties with heavy foliage may be undesirable in regions of heavy rainfall, especially when the boll weevil is present.

The flower bud has three large, green, leaflike bracts, and the bud, with these bracts, is called the *square*.

The flower (Fig. 87) is bell-shaped, 2 inches or more in diameter, having 4 or 5 short, green, abortive sepals, the same number of large, showy petals, many stamens, and a single pistil with as many stigmas as petals. The petals are white or cream-colored the first day that they are open, and pink the second day. The pistil ripens into the *boll* (Figs. 88 and 89).



FIG. 87. Cotton plants in full flower

The boll, which may be egg-shaped or nearly round (Fig. 89), is an inch or more in diameter. It has 4 or 5 compartments, each containing from 6 to 10 seeds. The seeds are covered with a dense growth of plant hairs, the *lint*. The seed and lint of a single compartment of the boll is called a *lock*.

**226. Long-staple and short-staple cotton.** The seed, together with the adhering lint, is called *seed cotton*. Of the varieties bearing large bolls, from 50 to 65 bolls will yield a pound of seed cotton. Of the small-bolled varieties from 100 to 120 bolls are required to produce a pound. An individual fiber is about  $\frac{1}{1500}$  inch in diameter. If the fiber is less than  $1\frac{1}{4}$  inches in length it is called *short-staple*; if more than this it is *long-staple* (Fig. 10).

Long-staple cotton brings a higher price per pound than short-staple, because the long fiber may be used for making fine, even threads of great strength for weaving cloth of fine texture, for laces, or for other expensive woven goods, whereas the short-staple is used in weaving the cheaper grades of cloth. Short-staple varieties are earlier in maturity and give larger yields than do long-staple varieties. The amount of long-staple cotton produced in the United States is a small fraction of the entire crop. Only the richer lands can profitably be devoted to the production of long-staple cotton.

**227. How the fiber is separated from the seed.** Seed cotton is carried to a *gin*, in lots of from 1200 to 1500 pounds. That amount may be conveniently tramped into a standard wagon box, and yields a bale of 500 pounds of lint, the standard commercial

package. A gin is essentially a set of fine-toothed circular saws and a set of hair brushes, with supplemental machinery for properly handling seed cotton and the separated products, seed and lint. The seed cotton is brought in contact with the revolving saws; the fiber is entangled in the saw teeth and pulled from the seed. The hair brushes are made to revolve in such a manner as to remove the entangled fiber from the saw teeth and deliver it to a press where it can be made into a compact bale. The bale is wrapped in coarse jute bagging and bound with six

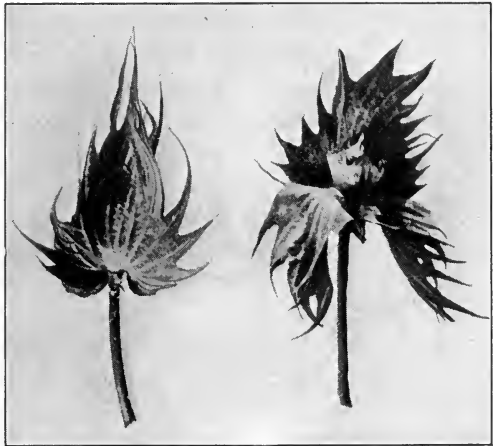

FIG. 88. The square and boll of cotton

At the left is a flower bud, or square, about two days before the flower is open. At the right is the young boll a few days after the petals of the flower have fallen to the ground

steel bands. A bale is usually about 54 inches long, 27 inches wide, and about 36 inches thick.

To save space in shipping, most cotton is prepared for long shipments by being compressed into half the volume of the ordinary bale. This is accomplished by very heavy pressure by means of ponderous machinery called a cotton compress. Round bales are made by a system of machinery that winds the lint into a cylinder of very compact form as it comes from the gin. Round bales weigh 250 pounds and are not compressed.



FIG. 89. Unopened cotton bolls

Different varieties of cotton have different forms of bolls

**228. Cottonseed products.** The primary function of a cotton oil-mill is to secure oil from cotton seed. The seed is "re-ginned," producing a small amount of very short-staple fiber called *linters*. The seeds are then cracked or chopped, and the kernels and hulls separated. The hulls are used as roughage for stock, or for packing material for breakable wares. The kernels are heated and compressed for the extraction of oil. When the oil has been extracted the residue is left in cakes about  $\frac{3}{4}$ -inch thick, called cottonseed cake. The cake is pulverized and becomes cottonseed meal. A ton of good cottonseed will yield approximately 800 pounds of hulls, 1000 pounds of kernels, from 25 to 30 pounds

of linters, and 125 pounds of trash. The 1000 pounds of kernels yield from 250 to 300 pounds of oil and from 750 to 700 pounds of cake.

**229. Cotton soils.** Cotton will grow in a great variety of soils, but always requires a well-drained soil. Some very poor hill lands produce fair crops under good cultivation, especially when properly fertilized. The very rich alluvial lands, especially when new, produce an excessive growth of stalk. The most productive cotton soils are the rich deep loams. Heavy clay soils produce late crops, and therefore are not so desirable for cotton, especially in the territory where the boll weevil is abundant.

**230. Climatic and weather conditions.** The most favorable season is a relatively dry spring, with warm nights, followed by abundant showers during the summer, and a dry fall. In the boll-weevil territory a week or two of dry, hot weather is much desired when the beetles become numerous. When the temperature ranges from 96 to 100 degrees F., the surface of the soil becomes hot enough to kill the boll-weevil larvæ that are in the fallen squares.

**231. Fertilizing the cotton.** The cotton crop receives more commercial fertilizer than does any other crop grown in the United States. If the lint alone were marketed, and the cottonseed meal and stalks plowed under, no other crop would remove so little fertility from the soil.<sup>1</sup> However, since cotton is a crop of clean cultivation the soil is left bare and much deterioration of soil comes through erosion and leaching. In cotton-growing districts crop rotation is not so generally practiced as it should be.

For cotton a complete fertilizer is generally used, the composition being varied to suit different localities. The farmers frequently mix their own fertilizers from cottonseed meal and acid phosphates. On average land a mixture of equal parts of cottonseed meal and acid phosphate containing 6.88 per cent

<sup>1</sup> A bale of cotton lint, a fair yield from an acre, contains about  $\frac{1}{4}$  pound of phosphorus,  $1\frac{1}{2}$  pounds of nitrogen, and 2 pounds of potassium. Contrast the amounts of plant food removed by cotton with that removed by corn.

phosphorus or 16 per cent phosphoric acid, applied at the rate of four hundred pounds per acre, either before planting or during cultivation, gives good results where cotton has not been preceded by cowpeas. More phosphate and less meal, or simply less meal, is used if the crop follows cowpeas or clover. Where a rotation is practiced, with cowpeas and some kind of clover, it is not necessary to purchase much nitrogen in the form of commercial fertilizer. Potash is desirable in some localities, and is generally supplied in the form of kainite, in sufficient quantity to have the fertilizer contain 2 per cent of potash.

**232. Planting and cultivating.** The best results are obtained when the land is well prepared in time to allow the soil to become well compacted before the seed is planted. With tenant farmers and with a large percentage of the land owners the practice is to "split the middles" of the former rows either with a double moldboard or with two furrows of a single plow, then distribute the fertilizer and turn back the soil with the four furrows, then harrow and plant. Under the best system now recommended, cultivation of the crop begins with a thorough harrowing before the cotton is up, and the subsequent use of surface cultivation as often as once a week if possible. When the land is inclined to run together, the row may be barred off<sup>1</sup> when the plants are from one to three inches high. The crop is thinned to one or two plants in a hill, the hills being twelve or fifteen inches apart in poor land and farther apart in richer lands. The dirt is worked back with a disk cultivator or with small shovels. The one-horse implement is very extensively used, and an expert may accomplish nearly any desired result with a "heel sweep" and a harrow. A second thinning is generally practiced, leaving only one stalk in a hill. This is done when the plants are safe from injury from cutworms and cold weather. When the soil is in good condition, barring off is not necessary, though it may lessen to some extent the work to be done with the hoe. The crop should be cultivated often enough to keep down the weeds and grass.

<sup>1</sup> The soil thrown from the plants with a turning plow.



**233. Harvesting.** The most expensive and tedious part of the production of cotton is the harvesting, which has to be done by hand (Fig. 90). Picking machines of moderate efficiency have been invented, but they are too expensive to be within the reach of the average cotton grower. Picking cotton is an important problem in the economic development of the South. If machinery could be used for thinning cotton to the proper



FIG. 90. The usual method of harvesting cotton

A fortune awaits the person who supplies a machine which will pick cotton efficiently and economically

stand and a machine were available for picking the crop, cotton production would immediately be revolutionized.

**234. Increasing the yield by seed selection.** The work that has been done in improving strains of cotton or in adapting them to special conditions indicates that the plant yields readily to intelligent selection and breeding. The average farmer cannot go into systematic breeding; that must be left to the specialist, but most farmers should practice field selection of seed. Attention to this matter will return a good profit. The best time to select plants from which to obtain seed is during the second

picking. The grower should study the characteristics of the leading varieties, take up new ones cautiously, and try to keep the adopted variety true to type and constantly improve it by selection.

The following are some of the points to keep in mind in selection: short joints indicate a tendency to early maturity; bolls of five locks have more weight of seed cotton than bolls of four locks; locks that are liberated from the burs by excessive opening are not resistant to storms, while some bolls may not open sufficiently to make picking easy; an intermediate degree of storm resistance should be sought; bolls that droop on the stem are desirable; earliness and long staple are to some extent incompatible; stalks with large bolls generally have fewer bolls; large seeds indicate a small percentage of lint; resistance to disease is more or less hereditary.

**235. Insect enemies.** The insects most destructive to the cotton crop are the boll weevil, the bollworm, and the caterpillar. Of these the boll weevil is the most destructive in the territory now infested. (See Chapter XXVI, Insects on the Farm.) The caterpillar eats the leaves of the cotton in the late summer. Since the invasion of the boll weevil the caterpillar often serves a good purpose in cutting off the food supply of the weevil. Poisoning with Paris green serves well as a remedy against the caterpillar.

**236. Diseases of cotton.** The cotton plant is subject to attack by a number of fungous and bacterial diseases that are sometimes quite destructive. Probably the worst fungous disease is the *cotton wilt*.

Anthraxnose is a fungous disease that attacks both the bolls and the stems, destroying the tissues and causing the infected portion to rot. The disease is transmitted from one season to another on the seeds of cotton. Seeds that are two years old are free from the disease, since the fungus dies in that time. Means of combating the disease, therefore, are either to secure clean seed from noninfected cotton or to plant seed that is two years old.

Boll rots are caused by various fungi and bacteria that cause the bolls to rot, especially when there is abundant rainfall. Injury to the surface of the bolls by insects permits entrance by these organisms, though some of them are not dependent on a broken surface for their entrance. Where these troubles are serious, one should try to secure seed from noninfected cotton and use varieties that do not produce excessive foliage. Early-maturing varieties and dwarf stalks are less damaged by these diseases than the later-maturing varieties of rank growth.

## II. FLAX

**237. Production and treatment.** Although flax is one of the important fiber crops of the world and is grown somewhat extensively in the United States, it is grown here almost wholly for the production of seed. Linseed oil, used principally in the manufacture of paints, is extracted from the seed; and the linseed cake, the product that is left after the oil has been extracted from the seed, is a valuable food for stock. The area devoted to flax in the United States is approximately two and three-fourths million acres, yielding about twenty million bushels of grain. The straw, aggregating several million tons, is usually wasted or burned. No attempt is made to recover from the straw the fiber it contains, although competent authorities<sup>1</sup> assure us it is quite the equal of the average straw from which the Russian peasants obtain the fiber for the principal linen fabrics of the world. The reason for this failure of the American farmer to utilize the fiber is, in large measure, the high cost of labor.

The fineness and quality of the fiber depend upon the thickness of the stand and the uniformity of the growth. When the flax is sown for the production of seed, only about one fourth as much seed is used as when it is sown for the production of fiber. Whenever the growth is checked by drought or other unfavorable conditions the quality of the fiber is injured. Flax

<sup>1</sup> *Farmers' Bulletin 274*, United States Department of Agriculture.

intended for fiber is pulled by hand, and in European countries the few seed bolls that form are stripped off by hand. The fiber is freed from the woody and gummy parts of the stem principally by fermentation and rotting. The straw, after it has been properly cured, is submerged for a time in water, and later exposed to the dew, rain, and sun. After the straw is *retted*, as this process is called, it is dried and later *broken* or *scutched*, which is the process of separating the fiber from the woody stems. The fiber is then ready to be graded and baled for the market.

### III. HEMP

**238. Nature and growth.** Hemp is closely related to the oldest cultivated fiber crops. It was introduced into New England by the early colonists, but its cultivation did not become important commercially. Kentucky produces the bulk of the hemp crop of the United States at the present time, though California, Missouri, Nebraska, and a few other states produce small quantities. The amount of hemp grown in the United States is decreasing because of the lack of labor-saving machinery for handling it and because the use of other fibers, particularly jute, is decreasing the market for hemp.

For the production of the best fiber, hemp requires a soil which is rich, moist, not acid, and provided with good natural drainage. Clay and other heavy soils usually produce a coarser fiber than do those which are sandy and light.

Hemp requires a humid temperate climate, and large areas in the valley of the Mississippi and its tributaries are adapted to the growing of this plant.

There are few insect pests and few plant diseases troublesome to hemp. The worst weed pests are bindweed and branched-broom rape. The roots of the latter grow upon the roots of the hemp.

Hemp should be seeded in early spring, either broadcasted or drilled about the time oats are usually sown. One bushel, or about forty-four pounds of seed, per acre is commonly used.

In harvesting for fiber, hemp should be cut when the staminate plants are in full flower. When cut earlier the fiber is weak; if later, it is coarse and harsh. As is the case with other crops, if the best quality of product is produced, continual care must be given to seed selection.

### QUESTIONS AND PROBLEMS

1. Compare cotton with corn as to importance in the United States. What is the money value of cotton in comparison with our other important crops?

2. What kinds of cotton are best adapted to the different kinds of soil? Why?

3. Why must the stand of cotton be thinned?

4. In what ways has the invention of the cotton gin affected the cotton industry? How has this affected other industries? Prepare a brief report on Eli Whitney.

5. Secure and present data upon the value of cotton seed or its products for feeding farm animals.

6. Upon an outline map of North America shade the regions where cotton is grown. Indicate in darker shading the regions where the best yields of cotton are made.

7. How is the land fertilized for cotton? What rotation of crops is best for cotton? If you are in a cotton-growing state, get your experiment-station reports upon the best rotations to be used.

8. How may quail benefit the farmer in connection with the cotton crop? Secure data upon the food of the quail and make class reports upon the question. Secure reports dealing with the cotton-boll weevil.

9. Why should the farmer pay attention to seed selection in growing cotton?

10. Should a Southern farmer raise cotton exclusively, or should he practice diversified farming? Give reasons on both sides of the question.

11. Discuss the importance and the uses of flax in the United States.

12. For what is flax straw used in Russia? Why is the straw not used in the United States?

13. Discuss the preparation of flax straw for market.

14. Give the history of hemp and discuss its importance.

15. When should hemp be seeded? When should it be harvested?

## EXERCISES

1. **The cotton plant.** Study ten or more stalks in a row where the stand is very good, and note the method of branching, kinds of branches found, length of internodes, and the number, size, and character of the bolls.

2. **Fiber.** By the aid of a comb, gently straighten the fiber adhering to the seeds of some of the known varieties of cotton, studying the length of fiber on different portions of the seed. Determine the relative weight of lint and seed.

3. Weigh the seed cotton from some of the best stalks and some average stalks and estimate the relative yield per acre.

4. **Effect of soil on crop.** When possible, study one or more varieties in different types of soil, noting height of main stalk, length of branches, number of bolls, size of bolls, prevalence of fungous diseases, time of maturity, storm-resistant characters, quality of lint, etc. Ascertain previous cropping of the field, and offer explanations of differences of yield on different plantations.

5. **Best varieties and their culture.** Secure data from your community regarding the following points in the cultivation of cotton: spacing in rows; methods of cultivation and reasons for practice followed; the yield of different varieties; variations in the yield of the same variety on different soils.

## REFERENCES

- DUGGAR, J. F. Southern Field Crops. The Macmillan Company.  
Cotton Selection on the Farm by the Characters of the Stalks, Leaves, and Bolls, *Circular 66*, Bureau of Plant Industry, United States Department of Agriculture.  
Factors Affecting the Production of Long-Staple Cotton, *Circular 123*, Bureau of Plant Industry, United States Department of Agriculture.  
Varieties of American Upland Cotton, *Bulletin 163*, Bureau of Plant Industry, United States Department of Agriculture.  
Sea Island Cotton, its Culture, Improvement, and Disease, *Bulletin 302*, United States Department of Agriculture.  
A Method of Breeding Early Cotton to Escape Boll-Weevil Damage, *Bulletin 314*, United States Department of Agriculture.  
A Profitable Cotton Farm, *Bulletin 364*, United States Department of Agriculture.

- Cotton Improvement under Boll-Weevil Conditions, *Bulletin 501*, United States Department of Agriculture.
- The Advantages of Planting Heavy Cotton Seed, *Bulletin 285*, United States Department of Agriculture.
- Egyptian Cotton in the Southwestern United States, *Circular 26*, Bureau of Plant Industry, United States Department of Agriculture.
- Improvement of Cotton by Seed Selection, Year Book of the United States Department of Agriculture, 1902, pp. 365-389.
- Cotton Improvement on a Community Basis, Year Book of the United States Department of Agriculture, 1911, pp. 397-410.
- Improved Methods of Handling and Marketing Cotton, Year Book of the United States Department of Agriculture, 1912, pp. 443-462.



## CHAPTER XVI

### GRASSES

Grass is the forgiveness of nature—her constant benediction. Fields trampled with battle, saturated with blood, torn with the ruts of cannon, grow green again with grass, and carnage is forgotten. Streets abandoned by traffic become grass-grown like rural lanes, and are obliterated. Forests decay, harvests perish, flowers vanish, but grass is immortal.—JOHN JAMES INGALLS

**239. Grass is our most important crop.** From the earliest time pasture has been the basis of live-stock production. The people who had good pastures had meat to eat, woolen clothes to wear, and good horses with which to subdue nature and conquer their enemies. It has been said that every civilization has progressed over a grass sward.

The steppes of Russia, the pampas of South America, the broad reaches of Australia, and the vast plains of America are the great pastures of the world and furnish most of the world's live stock.

The hay crop of the United States is exceeded in value by only one other crop, namely corn. The 65,000,000 tons of hay produced annually in the United States can sustain our live stock for only about one fourth of the year and must be supplemented by the equivalent of about 200,000,000 tons of feed, in the form of grain, forage, and pasturage.

Perhaps 95 per cent of our hay is made from plants, such as timothy, clover, alfalfa, cowpeas, and millet, which have been introduced from foreign countries; while more than 95 per cent



of our pasturage is produced by American species of grass plants, such as blue grass, buffalo grass, and the numerous species of the ranges.

**240. Cheap gains are made on pasture grass.** Were it not for pastures we should have to pay much more for our meat, milk, and wool, for they are produced from pasturage at much less cost than from any other sort of feed. A cow can be pastured at a cost of from 3 to 5 cents a day, and under such conditions will give as much milk as when fed moderately on grain and hay at a cost of from 12 to 15 cents a day. A steer at pasture will gain from 1 to 1½ pounds a day at an expense of 3 or 4 cents, or almost as much gain as it will make when fed grain and roughage at a cost of from 10 to 20 cents a day.

**241. Carrying capacity of pastures.** The carrying capacity of pastures varies from the best ones, which require 1 acre for 1 cow or steer for six months of the year, to the range pastures, which may require 10 acres for each head of cattle. In the best blue-grass regions of Kentucky, Tennessee, Virginia, and Missouri, the carrying capacity is about 1 head of cattle to 2 acres for half the year.

**242. Why grasses stand pasturing.** New growth is added to the tops of the stems and branches of most plants. Therefore when such plants are cropped or bitten off in grazing, the growth is checked until new stems and branches are sent out.

Grasses make their new growth at the base of the leaf; the lengthening blade is merely pushed along from below, and the growth for the time at least is not seriously checked by the removal of the tips of the leaves. In making new growth, however, leaves are just as necessary for grasses as for any other plants. It is not possible to secure the maximum yield with any species of grass when the leaves are closely cropped all the season, because there will not be enough leaf surface to organize the plant's food. Also, when grazed very closely throughout the season, grass has little opportunity to store food in its underground stocks, with which to sustain the plants during the winter and with which to begin growth in the spring.

**243. How grasses increase in number.** Grasses have three ways of multiplying : by means of seeds ; by underground stems, rootstocks, or bulbs ; and by stems or stolons which grow along the surface of the ground. Among the important grasses that spread in two or more ways are blue grass, Bermuda grass, buffalo grass (Fig. 91), brome grass, and redtop. Some other important grasses grow in bunches and send out new shoots from the

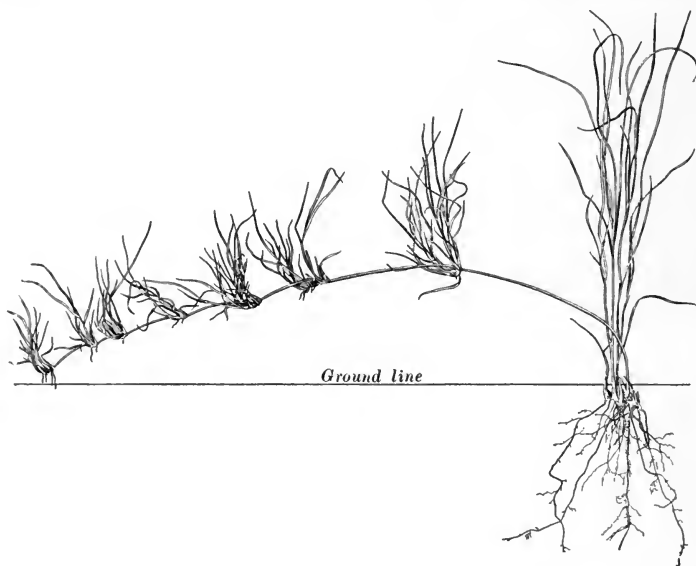

FIG. 91. Buffalo grass (*Bulbilis Dactyloides*)

From the nodes or joints of the runner new plants have developed ; the old plant has also produced new shoots at its base, and new plants are thus established

parent plant. Timothy, for example, sends out new shoots from its bulbs, and these in turn form bulbs from which other plants are produced (Fig. 92). This process of multiplying may be repeated several times in a single season if the stand is thin and if the weather is favorable. This explains why a thin stand in the spring may thicken by midsummer without reseeding the meadow. The underground rootstocks and bulbs serve also as storehouses for the reserve food of the plant, just as the

seed is the storehouse in plants like corn and wheat, and as the enlarged root is the storehouse in a plant like the beet. If the meadows and pastures are managed in such manner as to insure a good supply of food stored in the bulbs and rootstocks in the fall, the plants will winter in good condition and make an early and vigorous start in the spring.

**244. Mixtures for hay and pasture.** Over a greater part of the hay-producing region of the United States a mixture of timothy and red clover furnishes an excellent combination. Indeed, as a hay grass, timothy is of more importance in the United States than all other grasses combined. Fully nine tenths of the hay that reaches the market is made from timothy. In New England, redtop is more abundantly used and more highly valued than elsewhere in the United States, but even there timothy is the dominant hay grass. The first year that clover and timothy are sown together the hay is a mixture of the two. After the second year the stand is nearly pure timothy.

When timothy is to be grown alone, from 8 to 12 pounds of seed are sown to the acre. When timothy and clover are mixed, from 4 to 7 pounds of timothy and from 4 to 6 pounds of clover per acre are conservative amounts to sow. Where redtop is used, the following mixtures are suggested : (1) for moist, heavy soils, timothy, 8 pounds ; redtop, 5 pounds ; red clover, 4 pounds ; and alsike clover, 2 pounds ; (2) for light soils, timothy, 8 pounds ;

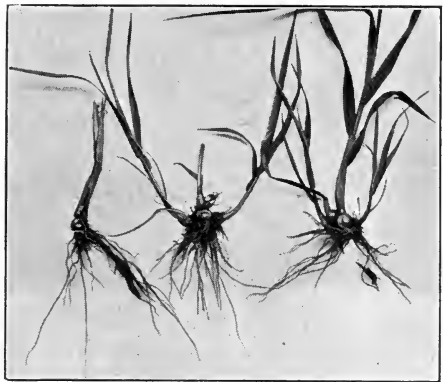

FIG. 92. How the timothy stand thickens

At left is a bulb with the last year's stalk attached ; in center, a last year's stalk in middle, with new shoots on each side ; at right, a vigorously growing plant with three new shoots. (Photograph from Missouri Experiment Station)

redtop, 3 pounds; orchard grass, 4 pounds; red clover, 6 pounds; and alsike clover, 2 pounds.

For pasturage on limestone soils in the humid regions north of the cotton belt, blue grass and white clover will soon have complete possession of the land, no matter what species are sown. Therefore, except to afford pasturage while these species are becoming established, there is little occasion to sow any other species than blue grass and white clover. Timothy and red clover are good forerunners of blue grass and white clover. If the soil is rich and much shaded by trees, it is well to sow orchard grass in the permanent pasture. If the soil is deficient in lime or is wet, redtop, English blue grass, and alsike clover should be sown. On light, dry soils, brome grass should be the principal element in the mixture.

**245. When and how to seed grasses.** Grasses may be sown in the fall or in the spring and with or without a nurse crop. A nurse crop is such a crop as wheat, oats, or barley sown with the grass to hold the surface from washing or blowing and to shade the young grass plants until they are able to withstand the intense heat. Legumes, with the exception of alfalfa, are usually sown in the spring. Fall is usually the better time in which to sow grass seed. If sown at this season, no nurse crop is required. Timothy is frequently sown on wheat in the fall. It may be sown at the time wheat is sown, preferably with a grass seeder attachment to the wheat drill, so that the timothy seed is sprinkled on the surface of the newly stirred soil to be lightly covered by wind or rain, or it may be sown alone on a good seed bed any time in August or September that there is sufficient moisture in the ground to insure germination and subsequent growth. When timothy is sown with wheat, no hay crop is to be expected the following year. When it is sown alone a full crop may be had. It may be seeded alone in the spring when the surface of the ground has been honeycombed, depending upon the subsequent freezing and thawing to cover the seed, or it may be sown in the spring with a nurse crop such as oats or barley.

**246. Timothy.** Timothy is a native of Europe and was originally called *meadow cat's-tail*, from the resemblance of the head to a cat's tail. Timothy Hanson, whose first name it now bears, brought it to America from England in 1720. Timothy was not considered of any agricultural importance in Europe until after it had been cultivated with success in the American colonies and had been taken back to England thirty or forty years afterwards, carrying with it its new name. In New England timothy is frequently known as herd's grass because it was introduced into New Hampshire by John Herd.

It is easy to understand why timothy ranks so high as a hay grass when we realize that it is the heaviest yielding hay grass known; the hay is palatable, easy to cure and keep, and is standard on all the markets of the country; a stand endures for years, and is quickly and cheaply obtained. This grass, therefore, meets the requirements of the hay farmer who wants to maintain a stand for a number of years, and also fits well into the plans of the farmer who practices a short rotation.

**247. How long timothy should stand.** A stand of timothy on rich land or if properly fertilized and not cropped or pastured too heavily will last almost indefinitely. The most generally approved practice, however, is to plow the sod under at the end of the second or third year. The land is usually put in corn after timothy, followed by oats, and then by wheat, which completes the rotation. Barnyard manure, if used, is spread on the sod the spring the sod is broken.

**248. When to harvest timothy.** From the earliest times there has been much discussion regarding the best time to cut grass for hay. Experiments have been made to determine when to harvest timothy to obtain the largest amount of hay having the highest feeding value and of the quality that stock relish most. It was found that by harvesting just after the bloom is shed, or about the time the seed is formed, but before the seed reaches the dough state, one secures the largest yield of nutritious hay. It was found that the earlier the cutting

was made, the better the stock liked the hay (Fig. 93). But early cut hay is difficult to cure and must be stored under roof to be kept well. Early cutting shortens the life of the plants and, except under the best management, soon "runs the meadow out." This is because the plants are harvested before they have filled their bulbs with food on which to nourish the plant in winter and to give it a good start in the spring.

**249. Kentucky blue grass.** Kentucky blue grass is a native of both America and Europe, and is widely distributed over the



FIG. 93. The time to cut timothy for hay

This illustration shows the results of a test of the palatability of hays cut at different stages of maturity. The same amounts of hay cut at times indicated on the labels were placed in this rack and yearling steers allowed access to the entire feeding rack. The results show strikingly which hay is most acceptable to the cattle. (Photograph from Missouri Experiment Station)

earth. It is the most highly esteemed and the most widely grown pasture grass in America. It requires a rainfall of thirty inches or more and a limestone soil for its highest development. Its southern limit is about the northern limit of cotton, but it extends northward almost to the arctic region and as far west as adequate rainfall occurs. It reaches its highest development, however, on the limestone soils of Kentucky, Missouri, Virginia, Tennessee, Iowa, Ohio, Indiana, and Illinois.

Unlike most of the other species of cultivated plants, blue grass has fought its own way and has established itself without man's help. On soils adapted to it, blue grass crowds out all

other species and without care establishes and maintains a dense sod almost indefinitely. Blue grass crowds in where red clover has been grown and, if left unmolested, takes possession of the land. In this respect it sometimes becomes a pest. Indeed, the worst weed in the alfalfa fields of the blue-grass region is this grass. While all that has been said regarding the ability of blue grass to take care of itself is true, yet it responds to good treatment almost as readily and fully as any other farm crop.



FIG. 94. Gathering grass seed by machinery

In early farming, blue-grass and redtop seed were always gathered by hand. Such machines as are here shown have recently come into use for gathering seed

**250. Blue-grass pasture management.** To graze a pasture too early or with too much stock is hurtful to the pasture and is not good for stock. A pasture should be grazed in moderation in the spring and early summer when the plants are making their growth and storing food in their underground rootstocks. After the time of seed production (Fig. 94) it is not injurious to the stand to pasture quite closely until the second rapid growth period, which is immediately following the late summer rains. To crop grass closely when it is making the second growth is almost as hurtful as to overgraze it in early spring and for the same reason. The food stored in the rootstocks by the first

growth of spring is largely exhausted by the second growth in late summer and early fall, and close grazing at this time will hinder the plant from storing food for the next spring's growth. However, after the leaves have been formed in the fall, and have had time to gather and store food, there is no reason why the pasture may not be grazed closely. Indeed, under most circumstances, close grazing late in the fall is good practice.

**251. Renewing blue-grass pastures.** When pastures become very weedy, plowing and reseeding is the most effective remedy. The land is usually cultivated one season in corn, followed by oats, and then seeded to grass. Experience has shown that grass may be revived and reestablished by a liberal dressing of barnyard manure in August or early September, or by the application of a fertilizer containing 3 or 4 per cent of readily available nitrogen (preferably in the form of nitrate of soda or some organic form like dried blood or cottonseed meal) and from 6 to 8 per cent of available phosphoric acid. To plow up the pasture and, without manure, grow two or three exhaustive crops will unfit rather than fit the land for the production of grass.

**252. Keep the pastures clean.** Many farm pastures are overrun with weeds and brush, and there is little room left in which grass may grow. The most common weeds are the iron weed, the ragweed, thistles, docks, and horse nettles. To this list of weeds may be added two other plants, buck brush and hazel brush, which in some regions occupy much space in the pastures and are serious pests. Mowing twice a year for two or three seasons, and annually thereafter, and close grazing are about the only practical ways to destroy buck brush and hazel brush. Persistent cutting just when they are in blossom is the only effective way to hold the weeds in check.

**253. Canada blue grass.** Canada blue grass resembles Kentucky blue grass. The seed of Canada blue grass is frequently used as an adulterant of Kentucky blue-grass seed. Canada blue grass prefers a limestone soil and thrives wherever Kentucky blue grass is found. It is palatable but not productive enough to take the place of Kentucky blue grass.



**254. Meadow fescue.** Meadow fescue, or English blue grass as it is frequently called, likes a rich, moist soil and thrives well on land too wet for blue grass or timothy and too rich to be profitably sown to redtop. It is only moderately productive and furnishes only scant pasturage during the hot summer months.

**255. Orchard grass.** Orchard grass is a coarse bunch grass well adapted to rich land and thrives in the shade better than any other grass. It is the first grass to start in the spring and will afford satisfactory grazing several days earlier than any other species. It is not especially nutritious, and stock prefer other species when available. As a hay grass it has little to recommend it; the yield is small, except on the most fertile soils, and the hay is not very palatable.

**256. Brome grass.** Brome grass was recently introduced into America by the United States Department of Agriculture from southeastern Europe, where it is extensively used for both hay and pasturage. It appears to be well adapted to the porous soils and semiarid climate of the West and Northwest. It starts early in the spring, endures dry weather well, and is among the last of the grasses to be affected by frost in the fall.

**257. Bermuda grass.** The grasses most highly valued in the North do not grow well in the cotton states, since they do not thrive during the long period of warm weather. The South, however, is rich in forage plants adapted to hay production. Bermuda grass is the most important pasture and hay grass of the South. It grows vigorously from early spring until frost. The stems and leaves are killed by freezing, but the roots and under stems are perennial. In good soil it makes sufficient growth to produce good hay, and may be cut three times in a season in the extreme South, and twice in the Middle South. It is easily cured and highly nutritious. Bermuda grass produces seed, but few of the seeds grow well. Good seed is worth from \$0.75 to \$1 a pound. Therefore Bermuda grass is usually propagated by planting small fragments of the sod in which it grows. A mixture of Bermuda grass and white clover makes an almost perennially green pasture.

**258. Carpet grass.** Carpet grass is to the light and sandy soils what Bermuda grass is to the heavier and richer soils of the South. It reaches its greatest perfection on the light soils near the Gulf coast, but it is more or less common as far north as central Georgia and northern Louisiana. It is strictly a pasture grass, and will stand close grazing and heavy tramping better than any other grass in the Gulf region. It makes little growth after the first heavy frost, but it furnishes good winter grazing if it is not pastured in midsummer.

**259. Johnson grass.** Johnson grass gives a heavy yield of fair hay and affords good pasturage for a few years. It is so difficult to dispose of when it is desired to plant the land to another crop that its cultivation cannot be recommended. It is usually regarded as a bad weed.

**260. Rhodes grass.** Rhodes grass was recently introduced from Central Africa, where it is regarded as one of the best pasture grasses for dry soils. It is perennial, with long, round, tender leaves, and is propagated both by seeds and by roots. It promises well for the southern part of the Gulf states.

**261. Sudan grass.** Sudan grass, another recent importation from South Africa, gives much promise. It has a much wider adaptation than the Rhodes grass, is an annual, and seems especially adapted to regions of limited rainfall as far north as central Kansas.

#### QUESTIONS AND PROBLEMS

1. What is the relation of the growth of grass to the development of civilization?
2. What are the great pasture regions of the world?
3. How does the hay crop compare in value with other crops?
4. From what sources do we get our hay crop?
5. How do pastures affect prices of animal products?
6. What is the carrying capacity of the various kinds of pastures?
7. How are grasses enabled to stand pasturing?
8. How do grasses reproduce?
9. Compare the different grasses in relative importance.

10. What are the various mixtures of grasses which are adapted to different kinds of soils?

11. When and how should the various grasses be sown?

12. In what stage of development of timothy do the farmers of your vicinity usually cut their hay? How does this compare with the best time for cutting as shown by the palatability test in this chapter?

13. How should timothy meadows be handled in order to secure the greatest return?

14. What are the principal Kentucky blue-grass regions? Discuss the best methods of managing a blue-grass pasture.

15. Discuss each of the other grasses and tell that for which each is especially adapted.

#### REFERENCES

BAILEY, L. H. *Cyclopedia of American Agriculture*, Vol. II, pp. 131-144; 303-311. The Macmillan Company.

SPILLMAN, W. J. *Farm Grasses of the United States*. Orange Judd Company.

WILSON, A. D., and WARBURTON, C. W. *Field Crops*, pp. 268-411. Webb Publishing Company.

WING, Joseph E. *Meadows and Pastures*. Sanders Publishing Company. *Some New Grasses for the South*, Vol. II, Year Book of the United States Department of Agriculture, 1912.

Conditions affecting the Market Value of Hay, *Bulletin 362*, United States Department of Agriculture.

Canada Blue Grass, *Bulletin 402*, United States Department of Agriculture.

Market Hay, *Bulletin 508*, United States Department of Agriculture.

Meadow Fescue, *Bulletin 361*, United States Department of Agriculture.

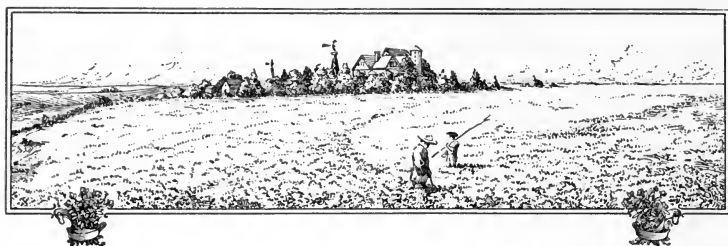

## CHAPTER XVII

### LEGUMES

Lupines and vetches for forage, if cut green, and the earth plowed above their roots, fertilize the lands like manure.— PALLADIUS

#### I. GENERAL STATEMENT

**262. The importance of legumes.** The great family of plants known as legumes is a necessary part of every system of agriculture. The legumes are the principal source of protein for man as well as for beast. More than half the people of the world eat beans, peas, and lentils instead of meat, milk, and eggs. Much of the protein feed of live stock is in the form of alfalfa, clover, cowpeas, and soy beans. The legumes have had an important part in making our soils fertile, and they have an equally important part in keeping them productive.

**263. Where legumes get their nitrogen.** All the nitrogen contained in corn, wheat, and other such crops comes from the soil. Much of the nitrogen of the legumes comes from the air. It has already been pointed out in detail how such plants as the clovers and peas gather nitrogen from the air through the activity of certain bacteria (Figs. 95 and 96). In the growing plant this nitrogen is combined with starch and mineral substances, such as phosphorus, and formed into what we call protein. Protein is very valuable for feeding live stock. When a plant is returned to the soil as a manure, the protein it contains is broken down; the nitrogen is changed into the form of a nitrate and is again available as plant food.

**264. How legume plants add nitrogen to the soil.** Nearly everyone who has lived in the country has heard men speak of clover as a fertilizer. It was not until the latter part of the last century, however, that the cause of the beneficial action of legumes was discovered. A careful examination showed that upon the roots of these plants are nodules which are literally filled with bacteria. It was demonstrated that these bacteria had the power to penetrate the root, causing the nodules to form, and then to take up free nitrogen and supply it to the plant in a form which the plant can use. It is therefore possible to maintain and even to increase the quantity of nitrogen in the soil through the growing of legumes.



FIG. 95. How legumes get their nitrogen

The peanut is an important crop plant in several mid-southern states. Its large and abundant root tubercles contain many bacteria which gather nitrogen from the air of the soil; and its fruit is a favored article of food. (Photograph from Virginia Experiment Station)

**265. Inoculation for legumes.** Different legumes have different kinds of bacteria which live on their roots. The kinds of bacteria which grow well on clover roots, for example, do not grow well on other legume roots. Not all soils are supplied with the kinds of bacteria which cause nodules on the roots of a particular legume, and it is often necessary to supply them. This is especially true

when legumes are introduced on soils on which they have not grown before. Inoculation is usually accomplished by scattering uniformly over the surface, at the rate of three hundred or four hundred pounds per acre, the soil taken from land where the legume in question has been grown. The field should be harrowed soon after the soil is scattered, to cover the bacteria and

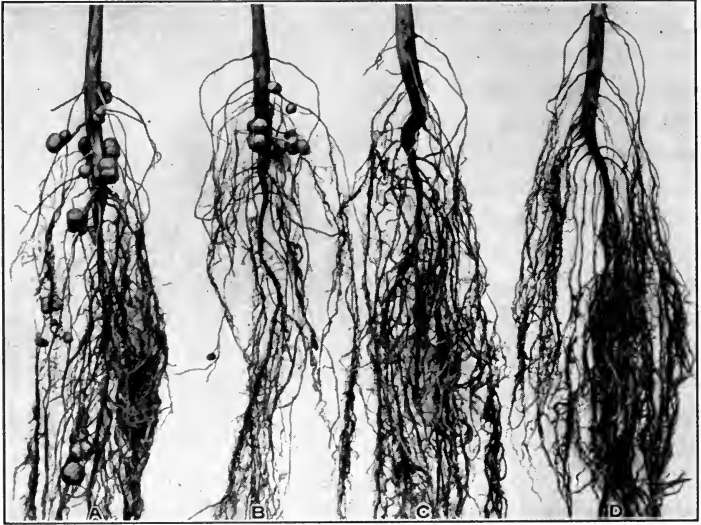

FIG. 96. Root tubercles on soy-bean plants

All but one of these plants were artificially inoculated, being placed for different lengths of time in solutions containing the proper kinds of bacteria. *A*, all night; *B*, one hour; *C*, ten minutes; *D*, not placed in the culture. The plants were grown separately in test tubes. (Photograph from Kentucky Agricultural Experiment Station)

thus prevent their injury by drying or the sun's rays. Recently there has come into use a method of inoculation of the soil with prepared cultures of the desired bacteria. These are proving fairly satisfactory. In most parts of the United States soils seldom need inoculation for the clovers, cowpeas, or field peas. Inoculation is frequently desirable or necessary for alfalfa and soy beans in fields where these plants have not previously been grown.

## II. RED CLOVER

**266. Importance of red clover.** Red clover is believed to have been domesticated within comparatively recent times, and to have originated either in western Asia or in eastern Europe. It was introduced into England about three hundred years ago and a hundred years later was brought to America, where its distribution and use are very general.

The value of red clover can hardly be overestimated, since over a large part of the United States it is the only crop generally used which has the power of utilizing the abundant supply of nitrogen in the air and adding this element to the soil. Also the physical condition of the soil is greatly improved by growing clover upon it, because the clover plant loosens and aerates the soil thoroughly and deeply. Red clover, being a biennial, is well adapted to use in short rotations, and this, together with its high value as a feed for all classes of live stock, is largely responsible for the important place it has in agriculture.

**267. Distribution and adaptation.** Red clover is particularly adapted to the area north of the Ohio River and east of the Missouri River. It is grown to some extent in every state of the Union. Red clover will grow on almost any soil of reasonable fertility, but it is difficult to secure a satisfactory stand and growth on soils that are low in lime or phosphorus, or on soils that are acid or water-soaked. Land which is good for corn is usually good for red clover. It grows best on fertile, friable, loamy soils, well supplied with lime, phosphorus, and potassium.

**268. Getting a stand.** It is safe to estimate that half the sowings of red clover fail. Most failures are due to lack of sufficient moisture in the surface soil to sustain the young clover plants. This lack may arise by allowing the nurse crop with which the clover was sown to mature, thus exhausting the soil, or because the soil is so low in organic matter that it has lost a part of its capacity to hold water. Again, the absence of sufficient lime in the soil or the presence of too much acid

may prevent a stand. The bacteria of clover tubercles do not thrive in a soil that is acid. The best results with bacteria are obtained if the soil is slightly alkaline. The results of recent investigations show that probably half the soils in the clover-growing region are either acid or neutral. To correct this condition, lime is being extensively used. It is usually not necessary to inoculate the soil with bacteria when sowing clover, but it is desirable to do so on soils that have become acid.

**269. The choice of a nurse crop.** The practice of sowing clover and similar seeds with a nurse crop is almost universal,



FIG. 97. A field of red clover ready to be cut for hay

but not always commendable. Winter wheat is the best nurse crop to use, because the wheat is harvested early in the season and does not smother the young clover plants or exhaust the moisture to the same extent as other crops. Barley makes an excellent nurse crop. Oats, used perhaps more generally for this purpose than any other cereal, is a poor nurse crop, because it requires a large amount of moisture for its own growth, produces a dense foliage which smothers the young clover plants, and is harvested late in the season when the rainfall is low and when the sunlight and heat are intense. When oats is used as a nurse crop the rate of seeding of the oats should be



reduced from one third to one half, to give the clover plants a chance to develop.

**270. How and when to make clover hay.** The best time to cut clover for hay is when a majority of the heads are a little past full bloom (Fig. 97), or when the first heads are beginning to turn brown and the last heads are opening. At the season of the year when clover hay is made, the soil and air contain much moisture, the weather is unsettled, and heavy dews occur at night. Even when the weather is favorable, by the time the

large succulent stems have become sufficiently cured to be safely stored the leaves have become so dry that often they are lost in the process of raking and handling the hay. Since the leaves and fine stems are the best part of the plant for feeding purposes, this loss seriously affects both the quality and the quantity of the harvest. If clover is exposed too long in the process of curing, it becomes

sunburned, loses its bright color, and becomes harsh and unpalatable. After the hay is partly cured it is easily injured by rain or by a heavy dew. To overcome all these difficulties the hay should be cured as much as possible in windrows and shocks instead of in the open swath. In this way the leaves are kept moist by the stems until the entire plant is cured. Protection against rain may be secured by canvas covers for the hay shocks.

**271. Seed production.** The first cutting, or the hay crop of clover, produces very little seed. The second crop is used for pasturage or for seed. The chances of getting a seed crop are



FIG. 98. Bumblebees, while securing nectar, help to pollinate red clover. (Photograph from the Iowa Experiment Station)

increased by cutting the first crop a little earlier than usual. Red clover is almost entirely dependent upon the aid of insects, especially the bumblebee, for the pollination of its flowers (Fig. 98). It has recently been discovered that during moist weather the pollen of red clover swells and bursts and is therefore useless to the plant. The abundance of some of the pollinating insects and the amount of rainfall during July and August largely determine the yield of seed. From two to four bushels of seed to the acre is the customary yield, although as much as seven bushels per acre has been obtained.

### III. ALFALFA

Of all those plants which please us, alfalfa is the most excellent; because one sowing lasts ten years, and affords commonly four, sometimes six cuttings in a season; because it enriches the land that produces it; and fattens all kinds of lean cattle. — COLUMELLA

**272. History.** The history of alfalfa began many years before the Christian era. It probably had its origin in the valleys of Media, in western Asia, whence it gradually spread westward to Persia and Greece, and then to Italy, Spain, France, and Germany.

Alfalfa was first introduced into the United States about 1791, at which time it was grown in New York, but with only moderate success. In 1854 small quantities of alfalfa seed were carried from Chile to California by gold seekers, who in their passage around South America on their way to California had stopped off in Chile and there saw the wonderful alfalfa fields. In California it quickly gained a foothold. From California it spread through the Western states and as far east as Kansas and Nebraska. East of the Missouri River its progress has been slow, although the acreage is increasing rapidly as far north as Minnesota, Wisconsin, and the Dakotas, and as far south as Alabama and Mississippi. The distinctive alfalfa belts are central Kansas, south-central Nebraska, central California, and parts of Colorado, Utah, Idaho, Montana, and Oregon.

**273. The soils suited to alfalfa.** Alfalfa is very sensitive to acid in the soil ; therefore it cannot be grown upon a soil that is not at least neutral, and the soil should be distinctly alkaline. A stand of alfalfa soon perishes under conditions which are not favorable for the development of the bacteria that gather nitrogen from the air. It is a deep-rooted plant, and on that account must have a deep soil (Fig. 99). Alfalfa produces enormous yields, and therefore must have a soil that contains sufficient nourishment for the plants and, particularly, enough water to sustain a large growth. Hence a loamy soil, drained and aired to considerable depth, is required. Soils which are very light or sandy are not the best soils for alfalfa, since they are likely to be low in fertility, though this may be largely overcome through the use of an abundance of manure. Compact clay soils or soils underlaid with hardpan are not good for alfalfa.

**274. Manure and lime.** Before the young alfalfa plant has established its root system so as to give it a large feeding area, and before the bacteria have developed in sufficient numbers to



FIG. 99. Crown and roots of alfalfa

This is an old alfalfa plant, and its roots had penetrated so deeply into the soil that in removing the plant only the few large roots were secured

make available the supply of nitrogen in the air, an abundance of available plant food must be at hand. On most soils the use of manure is the most important factor in securing satisfactory results. While good stands and yields of alfalfa have been secured on fertile soils without manure, the use of manure has in almost every case lessened the risk of failure to get a stand and has greatly increased the yield. Alfalfa also requires a large amount of lime for a permanent stand and for its best development.

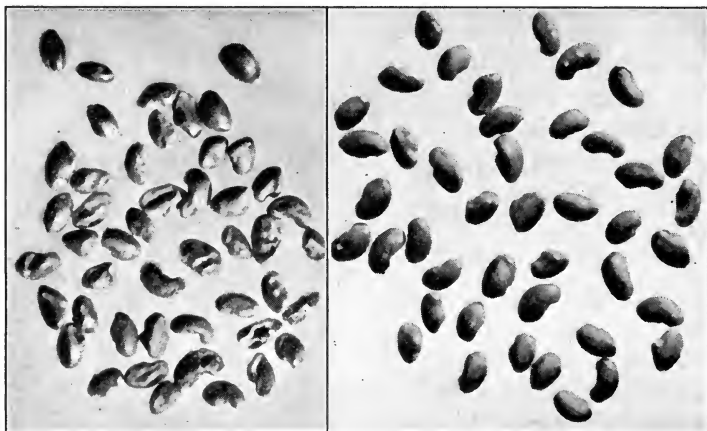

FIG. 100. Good and poor alfalfa seed

At the right are samples of good seed — pure, plump, smooth, and bright; at the left are samples of poor seed — irregular, shrunken, and discolored. (Photograph from Iowa Experiment Station)

**275. Varieties of alfalfa.** There are several varieties of alfalfa, such as the Turkestan, Grimm, Arabian, Peruvian, and American. At least 85 per cent of the alfalfa grown in the United States is of the common American type. The Turkestan is somewhat more resistant to cold and drought, and is used somewhat extensively in the Northwest. The Arabian and Peruvian types are common in the Southern states; and while they yield considerably more than the American type, they lack hardiness and are adapted only to the South. The Grimm is a very hardy type, but its seed is expensive, and it is not yet very generally grown.

**276. The seed bed and seeding.** The most common method of seeding alfalfa is to sow it in the spring either with or without a nurse crop. The land should be plowed in the fall, left rough through the winter, and thoroughly worked in the spring before spring seeding. This method is successful on soils well adapted to alfalfa and in favorable seasons. The safest method, especially in humid regions, is to sow in August, or very early in September, on summer-fallowed land. On account of the increased expense of preparing the seed bed, and also because of the loss of the use of the land for a year, this method is not so generally followed as it should be.

From twelve to twenty pounds of seed to the acre should be sown. The seed (Fig. 100) should be drilled, if possible, in order to place it at a suitable depth in the soil.

**277. Duration of the stand.** Alfalfa is a perennial, and under favorable conditions a stand may endure indefinitely. There are records of stands that have remained productive for as many as sixty years. However, in the best farm practice, alfalfa is plowed at the end of from five to eight years. In a humid climate the best yields are secured during the first five or six years. At the end of this period blue grass and other plants begin to crowd the alfalfa plants.

**278. Alfalfa in rotation.** Alfalfa is sometimes used in short rotations instead of red clover, in which case such a rotation as corn two years, oats or barley one year, and alfalfa two years, is to be recommended for general use in the corn belt. Alfalfa is better adapted to a longer rotation, and it is best to leave it undisturbed for four or five years at least. By dropping the alfalfa field out of the regular rotation for a few years and practicing short rotations on the other fields in the meantime, alfalfa can be grown on the various fields in successive groups of years. The most practical way to utilize alfalfa in a rotation is to plow under a strip of the old field each year and seed a new strip equal in area to the one plowed under. Alfalfa leaves the ground comparatively dry. Therefore, unless the rainfall is abundant it is best to follow alfalfa with some such crop as kafir

corn or sorghum. The second and third years following alfalfa, corn or potatoes is the most profitable crop. The year preceding the sowing of alfalfa the land should be sown in wheat, oats, or barley, and not in an exhaustive crop like corn or sorghum.

**279. Making alfalfa hay.** Alfalfa should be cut for hay for cattle and sheep when one tenth of the flowers are in bloom (Fig. 101). When making hay for horses from one fourth to one half of the blossoms should be open. A safer guide to the time of cutting is the stage of development of the new shoots. It is important that the crop should not be cut until the new shoots have formed at the crown of the plant and have attained a height of one or two inches ; but cutting must not be delayed until the new shoots have made such a growth that they will be cut off. The first cutting will be ready to be harvested in May or early in June ; the second, in from four to six weeks ; the third, in August. A fourth crop may be harvested in September or October. In the South five cuttings are usually secured each year. The hay is cured in much the same manner as red clover (Fig. 102).

**280. Seed production.** Economical seed production is possible only in those sections of the country in which the rainfall is more or less limited. With an abundance of moisture the plants produce a heavy growth of foliage, and while many flowers are formed, few seed pods develop. When it is desired to produce a seed crop, the second or third crop is reserved for this purpose. When the alfalfa-seed crop is harvested a mower with a bunching attachment is used to gather it and to deposit it in small piles. If a huller is available the crop is threshed direct from the field ; otherwise it is stacked. A very little wet weather will greatly damage the seed. Alfalfa should be cut for seed when about half the pods have turned brown.

**281. Weed pests.** In the distinctive alfalfa regions of Kansas, Nebraska, Colorado, Utah, and California, crab grass and foxtail are the principal weed pests of alfalfa (Fig. 103). In the corn belt Kentucky blue grass is perhaps the worst weed in alfalfa fields, although crab grass and foxtail also do much damage.



FIG. 101. Alfalfa at harvest time

Alfalfa may be cut for hay three or four times each season, and if properly cured and stored the hay is unexcelled



FIG. 102. Stacking alfalfa hay

## IV. OTHER LEGUMES

**282. Sweet clover.** Sweet clover, or *Melilotus*, is a native of central Asia and for more than two thousand years has been utilized by the farmers of the Mediterranean region as a plant for bees and for forage and green manuring. It was brought to this country long before the Declaration of Independence, but until recently was not thought to have any agricultural



FIG. 103. Alfalfa seed, clover seed, and weed seed

Many kinds of weed seed are mixed with the alfalfa and clover seed. When sown, these produce weeds which occupy part of the soil, reduce the quantity and value of the hay, pollute the farm, and get into the next seed crop

value. Even yet in some localities it is regarded as an injurious weed. Sweet clover grows in all parts of the United States and on almost all soils. It grows well in humid and subhumid climates and is of value where the more important leguminous crops, like clover and alfalfa, cannot be successfully grown. The chief variety, Bokhara, is a biennial and produces a rank growth and seeds profusely. As a soil builder, especially in waste places and where the surface has been badly eroded, it has no equal. Sweet clover is a good forerunner of alfalfa, because it inoculates the soil for alfalfa, adds plant food to the soil, and with its large roots breaks up the soil to a considerable depth.

Farm animals do not relish sweet clover at first because of the woody character of the stems and because of the bitter taste and offensive odor of its foliage. They may be taught to eat it



green by grazing it early in the spring, before other species have started, or in midsummer, when it is the only green herbage in the pasture. The cured hay, cut before the blossoms appear, is made palatable at first by sprinkling brine over it.

**283. Japan clover.** Japan clover is a native of eastern Asia, and was first discovered growing in this country in 1846. It has since spread more or less completely over the entire area from southern New Jersey to southern Kansas, and southward to the



FIG. 104. Cowpeas

This field of cowpeas has been grown to be plowed under for soil improvement, or for use as hog pasture or for hay

Gulf. Probably this is the limit of its adaptability in the United States. It is of much importance in the South. Japan clover is an annual, coming from the seed about the middle of the spring and reaching maturity the following September or October. On most soils it attains a height of from 4 to 6 inches and is of value only for pasturage. On some soils, however, it grows to a height of from 12 to 24 inches and produces from a half ton to three tons of valuable hay. Japan clover produces seed in great abundance and reseeds itself.

**284. The cowpea.** The cowpea is an annual, and has perhaps a wider range in soil conditions than any other legume of agricultural importance. Unlike red clover and alfalfa, it is not sensitive to an acid condition of the soil. Like all other legumes, it does best on a soil reasonably open in texture, because the nitrifying bacteria need plenty of air for their best development, but it grows well on a compact soil. Cowpeas probably grow better on poor, worn soils than does any other large legume except sweet clover. Also in its power to withstand drought and to stand still, so to speak, during a protracted drought and then make a rapid growth and a satisfactory crop in a short time after the rains come, the cowpea rivals the sorghums. It is the legume best suited to short rotations, and is unrivaled as a green-manure crop (Fig. 104), especially on land badly washed or worn, since it gathers considerable nitrogen from the air and adds much organic matter to the soil. When clover is killed by the winter or by a drought, there is time to sow cowpeas to fill its place in the rotation and in the food supply for the stock. Cowpeas smother other vegetation, such as weeds; and, like other large legumes, they greatly improve the physical condition of the soil upon which they are grown. Cowpeas are excellent to precede such crops as potatoes, alfalfa, tobacco, tomatoes, clover, and wheat.

**285. Varieties of cowpeas.** There are fifty or more varieties of cowpeas, but fewer than a dozen are of real importance. Although the cowpea is essentially a forage and soil-improvement crop, the grain of some of the varieties is greatly relished as a table food. The varieties best suited for table use are of little agricultural value because they are the smaller kinds, as the Lady, Browneye, and Cream. The principal forage varieties are the Whippoorwill, New Era, Unknown (or Wonderful), Black, Clay, Red Ripper, Iron, Warren's Extra Early, and Crowder. The habit of growth of the varieties differs greatly. Some have an upright, bushy habit and bear seed profusely; for example, the Whippoorwill, New Era, Quoit, and Warren's Extra Early. Others have a pronounced tendency to vine, and

produce little seed if the conditions are favorable for the production of vine. The Unknown is a striking example of this sort, and the Clay has the vining tendency to a marked degree. There are other varieties which are upright and fruitful on thin or sandy soil, but vine and fruit sparingly on rich land. The Black is an example of this variety. Therefore the variety or type chosen should be selected for the particular purpose for which the crop is to be grown. If the maximum quantity of organic matter is desired, a rank-growing, vining variety like the Unknown, or Clay, or Black should be chosen. If hay is desired an upright sort, such as the Whippoorwill, New Era, or Warren's Extra Early, is to be preferred. For a catch crop, either for hay or as a green-manure crop after wheat or oats or with corn, one of the earliest-maturing sorts like the New Era or Warren's Extra Early should be chosen.

**286. Time and rate of seeding.** The cowpea is more sensitive to cold wet weather than to any other unfavorable condition. It should not be sown until late in the season, after corn-planting time, and may be sown as late as July 15 in an ordinary season. When cowpeas are grown for seed, they should be sown later than when grown for forage, as late sowing favors fruitfulness except in parts of the southwest where a lack of rainfall in late summer may reduce the yield of the late-sown crop. The rate of seeding varies from two to ten pecks of seed per acre, depending upon the variety and soil.

**287. Harvesting cowpeas.** The crop should be harvested for seed when one half to three fourths of the pods have turned yellow, but before any have opened. For hay, they should be harvested when the first pods turn yellow. For green manure the growth should be turned under as soon as possible after growth has ceased.

It is common in the South to pick the pods by hand and thresh the peas with a hand thresher or a small power thresher. All in all, there is no very satisfactory way of harvesting and threshing the grain or of cutting and curing the hay — and these are the factors that limit the use of the cowpea plant. Owing

to these facts, the seeds are expensive and frequently scarce. A remedy for part of the difficulty in cutting and curing the vines for hay is to be found in sowing peas with some upright crop, such as sorghum or corn, which serves to hold up the peas and enables the crop to be cured and stacked much more conveniently. A mixture of one bushel of cowpea seed to one-half bushel of sorghum seed to the acre is widely used in the South.

**288. The value of the hay.** Cowpea hay varies greatly in feeding value, according to the amount of grain it contains and the way it has been cured. Hay from plants of average quality easily ranks with clover in value, and the better grades of cowpea hay are quite the equal of alfalfa hay.

**289. The soy bean.** The soy bean is an annual, and is believed to be native to southern Japan, China, Indo-China, and Java. It has been in cultivation in China and Japan since before the beginning of the Christian era, and in those countries it is the most important legume grown. The soy bean has been known in the United States for almost a century, but it is only within recent years that attention has been attracted to its value in American agriculture.

**290. The vetches.** The important cultivated vetches include the common vetch (or tare), the hairy, sand, or Russian vetch, and the purple vetch. There is a spring and a winter strain of the common vetch. The principal production of vetch is in western Oregon and western Washington, where it is grown with winter wheat and winter oats as a hay crop. It is also used in the citrus districts of southern California as a green-manure crop, and in the Southern states to a limited extent as a forage crop with winter oats.

Other legumes of economic importance are white clover, a perennial occurring abundantly in pastures; alsike clover, a perennial adapted to wet soils and maturing late enough to combine well with timothy or redtop; crimson clover, an annual adapted to the south central Atlantic states and very valuable as a green-manure crop; and mammoth clover, a coarse, late-maturing type of red clover.

## QUESTIONS AND PROBLEMS

1. Discuss the process by which legumes get their nitrogen and by which they add nitrogen to the soil.
2. What are the best ways to secure proper inoculation of the soil when legume crops are to be grown?
3. Why is the nitrogen-gathering action of legumes regarded as of great importance?
4. In what ways is red clover of importance in the United States?
5. Estimate the number of acres of clover as compared with corn in your community.
6. What is the best procedure to secure a satisfactory stand of red clover?
7. When and how should clover hay be made?
8. What conditions especially favor the production of seed in red clover?
9. Farmers have grown clover and alfalfa for a very long time, but tubercle bacteria were discovered only recently. How did farmers discover the value of clover and alfalfa crops?
10. What soils are best suited to the growing of alfalfa?
11. Why are manure and lime required to obtain the best results in growing alfalfa?
12. How should the seed bed be prepared for sowing alfalfa?
13. How may alfalfa best be used in crop rotations?
14. When should alfalfa be cut for hay, and how should it be cured?
15. How is alfalfa cut when it is to be used for a seed crop?
16. A farmer purchased a cheap grade of red-clover seed, paying \$9.50 per hundred pounds for it. The best grade of seed was priced at \$12.50 per hundred pounds. An investigation showed that the seed purchased contained 64 per cent live red-clover seed, 8 per cent dead and broken red-clover seed, and 28 per cent weed seed and dirt. At what rate per hundred pounds did he really pay for live clover seed? What results in his clover crop would he probably secure by sowing the low-grade seed as purchased?
17. What are the uses of sweet clover?
18. Of what value is Japan clover? Where does it thrive?
19. Name some of the advantages secured by growing cowpeas.
20. What are the leading kinds of cowpeas?
21. What are the limiting factors in producing cowpeas?

## EXERCISES

1. Locate a vigorous growth of sweet clover, red clover, alfalfa, or cowpeas, and carefully dig up the roots, making certain not to break off the root tubercles. Place the roots in a pail of water, and slowly wash the plant so as to remove the soil. Estimate the number and size of the tubercles on a few average-sized roots.

2. How does the depth of the roots of these plants compare with that of corn, wheat, oats, or cotton?

3. If a farmer near your school will turn under a strip of heavy legume growth, and pasture or make hay from the rest of the field, then plant all the field to any grain crop the next season, an interesting record may be kept to show the results of these two methods of using legumes.

4. Secure samples of clover and alfalfa seed and discover how nearly pure the seed is.

5. By use of pictures of weed seeds try to determine what kinds of weed seeds are mixed with your clover or alfalfa seed, if any.

6. Select one hundred good seeds, plant, and determine what percentage grows.

## REFERENCES

COBURN, F. D. *Book of Alfalfa*. Orange Judd Company.

SHAW, THOMAS. *Clovers*. Orange Judd Company.

SHAW, THOMAS. *Soil Crops and the Silo*. Orange Judd Company.

Alfalfa, *Bulletin 339*, United States Department of Agriculture.

Canadian Field Peas, *Bulletin 228*, United States Department of Agriculture.

Cowpeas and Soy Beans, *Bulletin 309*, United States Department of Agriculture.

Lespedeza, or Japan Clover, *Bulletin 441*, United States Department of Agriculture.

Red Clover, *Bulletin 445*, United States Department of Agriculture.

Legume Inoculation, *Bulletin 315*, United States Department of Agriculture.

Leguminous Crops for Green Manuring, *Bulletin 278*, United States Department of Agriculture.

Peanuts, *Bulletin 431*, United States Department of Agriculture.

Sweet Clover, *Bulletin 485*, United States Department of Agriculture.

Seeds of Red Clover and its Impurities, *Bulletin 260*, United States Department of Agriculture.

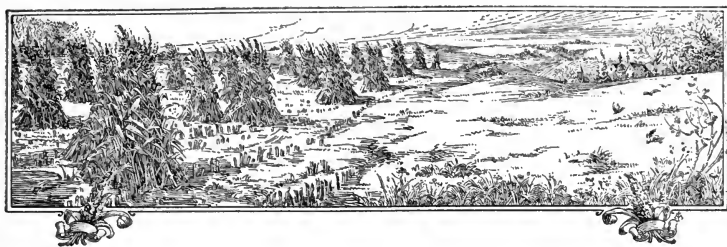

## CHAPTER XVIII

### FORAGE CROPS

**291. The sorghums.** Both the wild and the cultivated sorghums are native to almost the whole of Africa and to much of India. Many hundreds of forms are cultivated in these countries, as well as in China. The grain is used for human food, for feeding farm animals, and for making alcoholic drinks. The plants have varied industrial uses. The sorghums are large succulent annual grasses (Fig. 105), with jointed, pithy, more or less juicy, and sometimes sweet stems, with from eight to twenty leaves, and with perfect flowers borne in terminal heads. Under



FIG. 105. A field of pure-bred Black-hulled White Kafir

favorable conditions from one to many suckers are produced from the base, and when the plant is nearly mature, a branch may arise from each node, beginning with the second from

the top. The flowers are open and the pollen is carried through the air; consequently the varieties cross readily.

The sorghums grown in the United States are sorgo, broom corn, kafir, kaoliang, shallu, durra, and milo.

**292. Sorgo.** The sorgos (often called "cane" or sweet sorghum) were with one exception brought from Natal, South Africa, in 1857. Amber sorgo was brought from China to France in 1851.

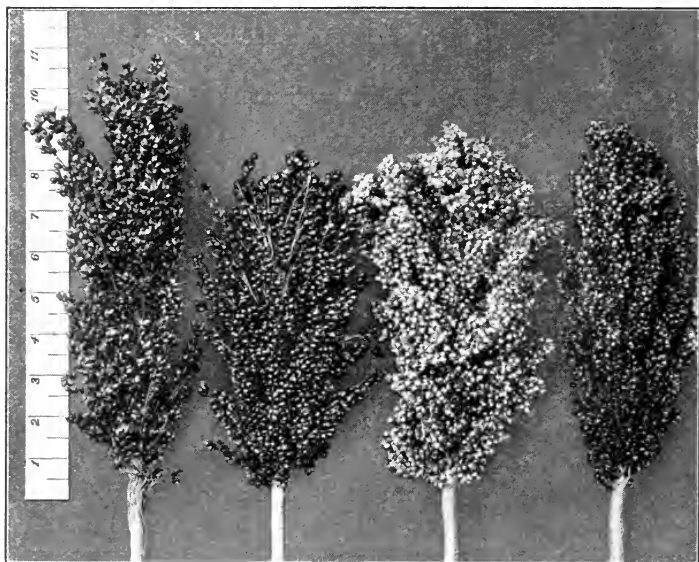

FIG. 106. Typical heads of standard varieties of sorghum  
1, Early Amber; 2, Black Dwarf; 3, Kansas Orange; 4, Colman

The flower and seed heads are short and dense, having numerous short branches. The pith contains a large quantity of sweet juice. The plants were first grown for sugar and sirup, but are now grown for fodder, hay, silage, and sirup. The leading varieties (Fig. 106) are Amber (Black, Red, Minnesota, and Dakota), Orange, and Sumac (Redtop). Others which are grown more locally are Planter, Collier, Sapling, Honey, Gooseneck, and Freed. All of these have brown seeds, except the Freed, which has white seeds.



**293. Broom corn.** Broom corn has greatly elongated branches. The entire flower head is usually spoken of as the "brush." The two chief forms are the Standard, which is from 10 to 15 feet in height (Fig. 107), with brush from 20 to 30 inches long, and the Dwarf, which is from 4 to 7 feet in height, with brush 12 to 18 inches long. The Standard is grown chiefly in Illinois and adjacent states; its heavy brush is harvested by cutting. The Dwarf is grown in Oklahoma, Kansas, and Texas; its brush is pulled or jerked.



FIG. 107. Cutting broom corn in central Illinois

Broom corn is a deep-rooted plant, and makes much the same demands upon the soil and is planted and cultivated in much the same way as Indian corn. It is sometimes used as a rotation crop with Indian corn, but this practice is not justified by experience. The brush is threshed or seeded, then cured in well-ventilated sheds, and then baled for market. The chief markets are Wichita, Oklahoma City, Kansas City, St. Louis, and Chicago. In Europe broom corn is grown most largely in Italy, Austria-Hungary, and Germany.

**294. Kafir.** The kafirs are stout, leafy plants with somewhat juicy stems, crowded leaves, erect heads, and egg-shaped seeds. They are natives of South Africa, and were first brought to the Plains area about 1888. They are now widely grown in Kansas, Oklahoma, Texas, New Mexico, and California. The kafirs are the principal grain producers among the sorghums and make excellent silage and forage of fair quality. The grain is largely

used for stock feeding and in poultry foods, while the meal is sometimes used for human food. The leading varieties (Fig. 108) are the Blackhull, Dwarf Blackhull, Red, and White.

**295. Kaoliang.** Kaoliang was recently introduced from China and Manchuria by the United States Department of Agriculture. The plants have dry and usually slender stems, with few leaves, and are of value chiefly for grain. Twenty-two varieties have been described, but only one,

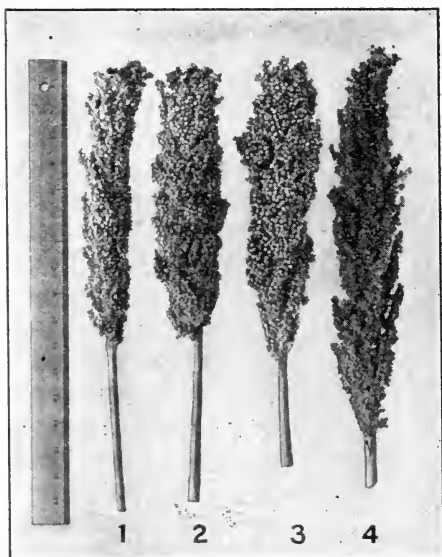

FIG. 108. Types of kafir corn

1, White Kafir; 2, Guinea Kafir; 3, Blackhulled Kafir; 4, Red Kafir

Manchu, is important as yet. It is becoming a staple farm crop in western South Dakota, and will doubtless extend throughout the west central states.

**296. Shallu.** Shallu is the only representative in the United States of a group which is common in India and tropical Africa. It has slender, dry stems, and is striking for its habit of sending out shoots from around the main stem, a habit called *tillering*. The heads are large, loose, and yellowish, with straw-colored

hulls. The plant is of little value for dry-land culture, although perhaps a good crop for irrigated land in the Southwest. It has been widely and fraudulently advertised as "California wheat," "Mexican wheat," "Egyptian wheat," "Palestine wheat," and "Desert wheat-corn."

**297. Durra and milo.** The durras, which include milo, have slender stems, dry pith, only from 8 to 10 leaves, compact, oval, sometimes pendent heads, and large, nearly round, flattened seeds. They come chiefly from northern and central Africa. They are smaller and earlier than the kafirs and less valuable for fodder, but better adapted to grain production in dry areas with short seasons.

**298. Feterita.** Feterita is a new variety of the durra group, which was brought to the semiarid West from Africa in 1907. It is marked by erect heads, white seeds, fairly dwarf stature, and early maturity. The seeds, however, are larger and softer, and do not germinate so well as the other sorghums. Although feterita promises to be of considerable value as a dry-land crop, it is yet too early to predict its permanent place and value as a forage crop.

**299. Regions favorable to sorghums.** Sorghums are especially adapted to warm, dry regions because of their ability to withstand drought. Some varieties also escape or evade drought through earliness or dwarf stature. They all excel corn in their ability to remain dormant during periods of drought and to recommence growth when the drought is broken. Several million acres are grown annually in Kansas, Oklahoma, Texas and the adjacent states, and in California.

**300. Culture.** Except when sorgos are drilled closely for hay, they are sown in rows about three and one-half feet apart and cultivated. They may be surface-planted or listed, according to local needs. They should be planted only after the ground has become warm, usually from ten to fifteen days later than corn. The young plants grow slowly at first and need clean land. The sorgos and kafir plants remain green until the seed is ripe. The leaves on durras, milos, and kaoliangs usually

become dry and break off before maturity. Harvesting is done sometimes with the row binder, the crop being shocked to cure, or sometimes the cutting is done with the header or by hand, and the heads are cured for threshing. In the latter case the stalks are grazed in the field or are cut for fodder.

**301. Rape.** Another forage plant, though not belonging to the sorghum group, is rape. It originated in northern Europe and is adapted to a cool climate and a rich, moist soil, although



FIG. 109. Pigs feeding in rape

Rape is the most valuable forage crop we have for hogs for a large part of the United States, alfalfa and red clover excepted

it withstands heat and drought almost as well as do the sorghums and cowpeas. Rape is related to cabbage, turnips, and mustard and produces a great quantity of large, succulent leaves and succulent stems which are much relished by hogs, sheep, and poultry. It therefore affords excellent pasturage from the beginning of summer until the first hard freeze occurs. Rape may be sown broadcast at the rate of three pounds of seed to the acre and harrowed lightly to cover the seed. A larger yield, however, will be obtained if it is sown in rows about two and one-half feet apart, at the rate of one and one-half pounds of seed to the acre, so that the soil may be cultivated frequently. Seeding may be done as early in the spring as it is

safe to sow oats. An excellent use of rape consists in sowing it in corn just following the last plowing of the corn, in which case it usually makes good late autumn pasture for hogs or sheep (Fig. 109). The yield of pasturage from rape is usually so large that a small area will supply the needs of the average farm.

**302. The millets.** Millet as used in the United States is a somewhat general term and includes a number of unrelated cereals and forage plants having small seeds. Millet seed is used extensively in India, Japan, Korea, and China for human food. In the United States the millets are of considerable importance for the production of forage, though this is chiefly as a catch crop, to supply in a rotation the place intended to be occupied by some other crop. The most important millet is the so-called German, or foxtail, millet. This millet is very old and is said to be one of five species of plants sown each year by the emperor of China in a public ceremony, in accordance with a command given twenty-seven hundred years before the Christian era. Hungarian, or common, millet and Japanese millet are also grown quite generally in the United States.

#### QUESTIONS AND PROBLEMS

1. What is the origin of the sorghums?
2. What is the origin of the sorgos, and for what are they now principally used? What are the leading varieties?
3. Where is each of the chief varieties of broom corn grown? How is broom corn harvested? How used?
4. What are the chief broom-corn markets?
5. What are the principal uses for kafir?
6. Under what kinds of soil and climate is kafir grown?
7. Compare the durras with the kafirs in characteristics, feed value, and production.
8. What may be said of the general adaptability of the sorghums? Are sorghums better adapted to regions of abundant rainfall or to semiarid regions?
9. How are sorghums usually cultivated and harvested?
10. For what is rape chiefly valuable?

11. Where did rape originate, and what other plants does it resemble?
12. How and when should rape be sown so as to secure the best results?
13. What are the chief uses of millet?
14. To what extent are the crop plants mentioned in this chapter grown in your country?

#### EXERCISES

1. Compare full-grown stalks of amber and of orange or sumac sorgo; also of kafir and milo. Count the leaves on each. Cut the stems and note the difference in quantity and sweetness of juice. Note the degree of maturity of the leaves of each crop when the grain is ripe.
2. Study heads of amber and of orange or sumac sorgo, of kafir, of milo, and of broom corn. Thresh a head of kafir or milo, weigh the seed, and calculate the number of seeds.
3. If your vicinity is one in which sorghum is grown for use in making sirup, secure the exact measurements of the size of several sorghum patches, also the yield in sirup from each one, and determine the average acre-yield in your locality.

#### REFERENCES

- BORMAN, T. A. Sorghums. The Kansas Farmer Company, Topeka.
- HUNT, T. F. Forage and Fiber Crops in America, pp. 1-274. Orange Judd Company.
- SHAW, THOMAS. Forage Crops other than Grasses. Orange Judd Company.
- VOORHEES, E. B. Forage Crops for Soiling, Silage, Hay, and Pastures. Best Sweet Sorghums for Forage, *Bulletin 458*, United States Department of Agriculture.
- Forage Crops for Hogs in Kansas and Oklahoma, *Bulletin 331*, United States Department of Agriculture.
- Saccharine Sorghums for Forage, *Bulletin 246*, United States Department of Agriculture.
- Forage Crops for the Cotton Regions, *Bulletin 509*, United States Department of Agriculture.



## CHAPTER XIX

### ROOTS AND TUBERS

**303. Value and importance.** Irish potatoes are grown in every state in the Union and furnish an important part of our food. Sweet potatoes are grown principally in the cotton states and, like Irish potatoes, are increasing in importance as a food crop. In 1913 the United States produced 331,526,000 bushels of Irish potatoes, valued at \$227,903,000, and 59,057,000 bushels of sweet potatoes, worth \$42,884,000. Beets, turnips, carrots, parsnips, and salsify are grown very generally in family and market gardens. They add much to the food supply and help to vary the diet. Stock beets and turnips are grown in the Northern states for feeding cattle, sheep, and poultry.

The Irish potato is a tuber (Fig. 110), or underground stem; the sweet potato, beet, parsnip, carrot, and salsify are enlarged roots.

**304. Soils adapted to roots and tubers.** Root crops may be successfully grown in a variety of soils and locations. The ideal soil, except for the sweet potato, is a deep, loamy soil well supplied with plant food but not too rich in nitrogen. The sweet potato succeeds best in a sandy soil. All these crops require a good supply of potash and phosphorus for the best results, and the soil must be supplied with liberal amounts of readily available plant food if a high quality and a satisfactory yield are to be secured. Soil that has been in a good state of tilth for some time previous is preferred. It is better to apply barnyard manure the season preceding rather than immediately

before planting root crops, because the decomposing manure is apt to force a heavy growth of top, and if the water supply is not abundant, the roots or tubers will not be well developed.



FIG. 110. An Irish-potato plant

The potatoes are much-thickened underground stems ; the roots extend much deeper and wider than the region where the tubers are formed

Also the larva of the insect known as the June bug or May beetle is likely to infest freshly manured soil and to injure the roots of growing plants, often even killing the plants.



**305. Time of planting.** The Irish potato and the sweet potato are both easily injured by frost. In many sections the earliness of the crop determines the profit, and it is a matter of importance that they be planted at a time which will insure an early crop and yet escape the frost. In the Southern states Irish potatoes are planted for the principal crop from December to February and are harvested and marketed in April or May. In the Central states potatoes are usually planted in March or early in April to supply the July and August market. The principal

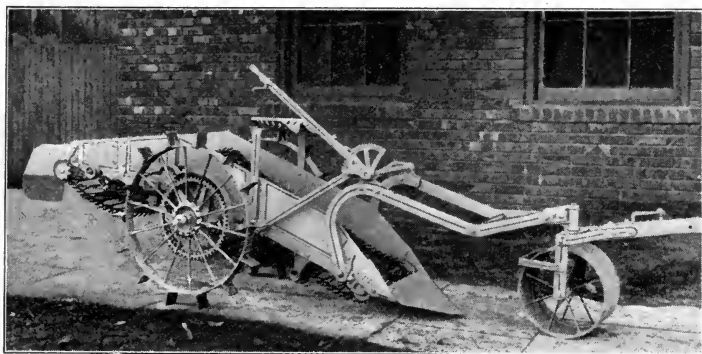

FIG. 111. A potato digger

In potato production, digging the crop is one of the most laborious and costly parts of the work. The use of such machines as that here shown is the least expensive method, when the potatoes are grown in large quantities; such machines also dig the potatoes with less injury to them, and at the same time put the soil in better condition for subsequent crops

crop is grown in the Northern states, and is planted as soon as danger from frost is past, and is harvested (Fig. 111) in the fall before the ground freezes. The yield per acre is larger in the Northern states than in the Southern or Central states, but the acre-value of the crop does not vary widely, because the potatoes that are sold as new potatoes bring a higher price.

**306. The potato.** The potato is propagated by means of the tuber, each "eye," or bud, possessing the power, under favorable conditions, of producing a new plant, which in turn stores in the new tubers the plant food prepared by the leaves. Tubers which

weigh from six to twelve ounces are most in demand. They should be of even form for the variety but always with the terminal end well developed and not pointed, the eyes well set but not deeply indented, and the skin the characteristic color and texture for the variety. From eleven to fifteen bushels of seed potatoes are required to plant an acre. The chief requisites of good seed potatoes are firmness and soundness, freedom from disease, with the eyes just showing indications of growth. Seed potatoes that have sprouted to any considerable extent are lowered in value. Northern-grown seed is usually preferred because it is less liable to sprout before planting time.

**307. Sweet potatoes.** The sweet potato is grown from plants which are produced in large number from the root. The roots are placed in a hotbed about six weeks before the plants are wanted. Sweet potatoes are usually grown on ridges formed by throwing two furrows together with a deep furrow between. By this method the vines are more easily cultivated and the digging more easily done. The ridges are about 4 feet apart, and the plants are set 12 to 18 inches apart in the row.

**308. Beets.** Beets vary in color, form, and size. It is believed that all our varieties, from the table beet to the sugar beet and mangel-wurzel (or stock beet), have been developed from the same foundation stock.

#### QUESTIONS AND PROBLEMS

1. How are sweet potatoes propagated? Irish potatoes?
2. What kinds of soils are best for Irish potatoes? for sweet potatoes?
3. When should manure be applied to ground used for growing root crops? Why?
4. What are the requisites of good seed potatoes?
5. What type of potato is most in demand?
6. Compare sweet potatoes and Irish potatoes as to production, value, and methods of cultivation.
7. What is the average acre-yield of potatoes in your state? Get the record of the best yield in your vicinity and compare it with the average for your state.

8. In a state where the average yield of potatoes per acre was 118 bushels, one farmer produced 386 bushels on a test acre. He estimated that his added expense above the average was \$35 for labor, fertilizer, and spraying. If potatoes were worth 50 cents per bushel, what was his gain over the average yield?

### EXERCISES

1. In a box of soil in the schoolroom, plant cuttings of potatoes, and after two weeks remove some of them and study the development of the different parts.

2. Place a potato upon the earth in a box, and when it begins to grow, observe the way in which new stems grow from the eyes. Sometimes these stems will form new small tubers in the open air of the room.

3. Plant sweet potatoes in soil in the schoolroom and see if you can start new plants.

4. If an experimental plot is available, plant one row of potatoes with cuttings which have one eye each, and another with cuttings having two or three eyes each. Cultivate alike and compare yields.

5. Secure from your state experiment station directions for spraying potatoes to prevent damage from insects and the blight. Spray one plot and leave another unsprayed, and compare yields.

### REFERENCES

FITZ, J. Sweet Potato Culture. Orange Judd Company.

GRUBB, EUGENE H., and GUILFORD, W. S. The Potato. Doubleday, Page & Company.

PINK, J. Potatoes: How to Grow and Show Them. The D. Van Nostrand Company.

Potato Culture, *Farmers' Bulletin 35*, United States Department of Agriculture.

Potato Diseases and their Treatment, *Farmers' Bulletin 91*, United States Department of Agriculture.

Potatoes and Other Root Crops as Food, *Farmers' Bulletin 295*, United States Department of Agriculture.

Suggestions to Potato Growers on Irrigated Lands, *Circular 90*, Bureau of Plant Industry, United States Department of Agriculture.

Sweet Potato, *Farmers' Bulletin 129*, United States Department of Agriculture.

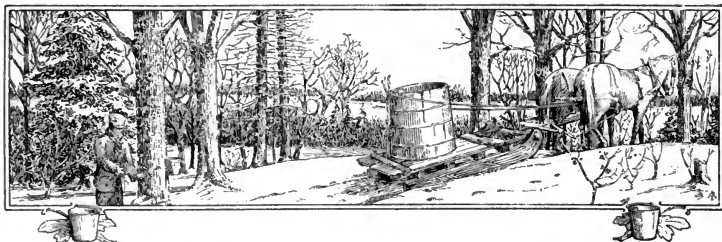

## CHAPTER XX

### THE SUGAR CROP

**309. Importance of the crop.** The world's production of sugar has doubled in the last decade. In this time the per capita production of bread has remained about stationary and the production of meat has declined. The use of sugar as a food is increasing in almost every part of the world. The average amount per year consumed by each person in England is estimated to be about 85 pounds and for the United States about 65 pounds. In Italy, Greece, and Turkey the yearly consumption of sugar is only about 7 pounds per person.

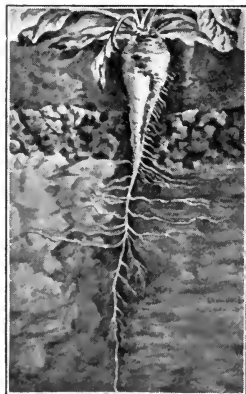

FIG. 112. The sugar beet.  
(Drawing from California  
Agricultural College)

The four important sources of sugar production in the United States are the sugar beet, the sugar cane, the sugar maple, and the honey bee.

**310. The sugar beet.** Nearly one half of the sugar supply of the world is obtained from beets (Fig. 112). The yearly production of beet sugar is approximately nine million tons, and has doubled within the past two decades. In the United States the production of beet sugar has increased more than threefold in the last ten years. The greatest acreage of sugar beets is found in Germany, Russia, and Austria-Hungary. These countries

produce over three fourths of the beet sugar of the world. The United States ranks fifth in acreage of sugar beets and produces about 5 per cent of the world's beet sugar. The most important centers of the industry in the United States are in Michigan, eastern Colorado, southern California, northern Utah, and northwestern Ohio.

**311. The sugar cane.** Sugar cane is a highly efficient plant for gathering human food from the earth and air (Fig. 113).



FIG. 113. Harvesting sugar cane in the Hawaiian Islands

Temporary railways are laid through the fields, over which the stripped cane is transported to the sugar mill

The principal cane-sugar-producing countries are British India, Cuba, Java, Hawaiian Islands, Philippine Islands, United States, and South America. The yearly cane-sugar crop of the United States and its possessions is approximately 1,250,000 tons. Until comparatively recently it was believed that sugar cane could not be grown except in the tropics, but it is now successfully cultivated almost anywhere between the latitudes of 33 degrees north and south of the equator.

Sugar cane was introduced into Louisiana by the Jesuits in 1751. With the exception of southern Louisiana and southern Texas, sugar cane is grown in this region chiefly for sirup. It

requires for its highest development a very fertile, well-drained soil and an abundance of moisture. For the best results as much as two inches of water per week are required during the growing season. Sugar cane produces seed very sparingly and only a few of the seeds will germinate. At each joint of the stalk there is a bud, or eye, and the stalks, or canes, are planted



FIG. 114. Planting sugar cane

New plants sprout and grow from the joints of the old stems which have been covered with soil

(Fig. 114) from April to October in rows about five or six feet apart, with a continuous line of stalks in the rows. The young plants spring from the buds. In tropical countries one planting may yield several yearly crops, but in the United States one planting seldom yields more than three crops, and usually only one crop is produced. In Hawaii the sugar land is sometimes plowed to a depth of two feet by means of steam plows, and the stalks are planted at a depth of six inches or more.

**312. The sugar maple.** Maple sugar and maple sirup are products of a distinctly American industry, the United States and Canada being the only countries in which these products are made. The Indians were making sugar from the maple trees during the period when the earliest settlers came to America, and this was the chief sugar used by the early settlers.

The amount of maple sugar and sirup produced is not of great commercial importance. While all the maples have a sweet sap, it is only from three species—the sugar maple, the black maple, and the red maple—that sugar is made in commercial quantities. Indeed, it is from one species, the sugar maple, that almost all the sugar and sirup are made. This species is very widely distributed, extending from eastern New England, New York, Tennessee, the southern Appalachians, the Ohio valley, the Lake states, and the adjacent parts of Canada, and extending as far south as Arkansas. A sugar maple tree yields from 10 to 20 gallons of sap during the season. The sap will average about 2 per cent of sugar. Thus a tree will yield from 2 to 3 pounds of sugar or about three pints of standard-grade sirup.

**313. The honey bee.** The honey bees of the United States produce annually from 175,000,000 to 200,000,000 pounds of honey, valued at about \$24,000,000. So great has been the growth of the beekeeping industry that the United States, from a mere beginning in 1860, now leads the world in the value of bee products and in progressive methods of bee culture. California is the leading honey-producing state.

Honey is used extensively in the manufacture of cakes and cookies, because it has been found that honey is a preservative as well as a sweetener. Honey is also used largely for sweetening and flavoring soft drinks and, to some extent, in sweetening hot drinks, such as coffee and tea. Beeswax is used extensively in the arts and sciences.

The Italian bee, introduced in the United States in 1860, is now the most profitable variety and, in varying degrees of purity, is found in nearly all parts of the United States. The German,

or "black," bee still persists, but is rarely found pure. Nearly all of the hybrids in the country are crosses between Italian and German bees. In some localities either the Carnolians or the Cyprians are found, but these races have never become popular in the United States.

Some of the principal nectar-producing plants are the clovers, especially white clover and sweet clover, buckwheat, mountain sage, goldenrod, catnip, horseweed, black gum, linden (basswood), tulip, sourwood, magnolia, locust, chestnut, and mesquite.

Honey is in demand in almost all markets throughout the year. The rate at which thrifty bees store honey in favorable seasons makes the bee-keeping industry much more remunerative than is ordinarily appreciated. Too often, the farmer expects his bees to produce honey without any of the kind of care needed by all productive farm animals.

#### QUESTIONS AND PROBLEMS

1. What is the relative importance of the sugar crop in the world as compared with other crops.
2. What are the most important sources of the sugar produced in the United States?
3. What are the regions in the United States in which sugar beets are most extensively grown?
4. What countries have the greatest total acreage of sugar beets?
5. Describe the soil, climate, and methods of cultivation which are best for sugar beets.
6. Describe the sugar-cane plant, its cultivation, and the processes of making sugar from it.
7. What part of the world's sugar is made from sugar cane? What are the principal cane-sugar producing countries?
8. What is the history of the maple sugar and sirup industry? How important is the maple sugar industry?
9. Secure from a text in zoölogy or from an experiment-station bulletin a good description of the kinds and number of honey bees which compose a hive. Describe the colonial life of honey bees.
10. In what ways could the growth of bees be made more profitable in your community?



## REFERENCES

- MARTINEAU, G. Sugar, Cane and Beet. Pitman Publishing Company.
- MYRICK, H. American Sugar Industry. Orange Judd Company.
- The Maple Sugar Industry. *Bulletin 59*, Forest Service, United States Department of Agriculture.
- Sugar-beet Growing under Humid Conditions. *Farmers' Bulletin 568*, United States Department of Agriculture.
- The American Beet-Sugar Industry. *Bulletin 260*, Bureau of Plant Industry, United States Department of Agriculture.
- The Sugar Beet : Culture, Seed Development, Manufacture, and Statistics. *Farmers' Bulletin 52*, United States Department of Agriculture.

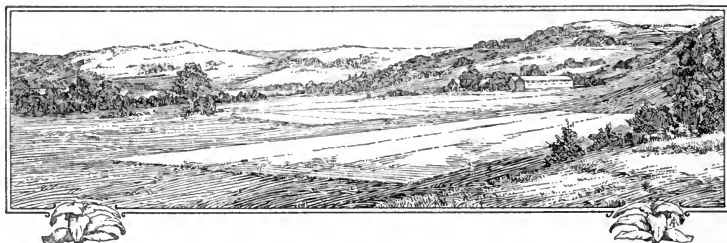

## CHAPTER XXI

### TOBACCO

**314. Tobacco as a farm crop.** Tobacco was first commercially grown in Virginia in 1612. This crop now ranks seventh in value in the United States and ninth among the crops of the



FIG. 115. A topped tobacco plant. (Photograph from United States Department of Agriculture)

world. The tobacco crop of the world is about 2,500,000,000 pounds a year, of which the United States produces nearly 1,000,000,000 pounds.

The tobacco plant (Fig. 115) may be grown successfully on any agricultural soil and in all latitudes from southern Canada to the tropics. The quality of the product, however, is perhaps affected to a greater

degree by the conditions under which it is grown than is that of any other farm or garden crop. Therefore tobacco production has become a highly specialized industry, a given district supplying only certain classes, or types, of tobacco, as the cigar leaf in certain districts and the cigar wrapper in others.

**315. Classes and types.** The three general classes of tobacco are (1) cigar tobaccos, (2) export tobaccos, and (3) manufacturing tobaccos. Each class is divided into numerous types, or subclasses, depending upon the special use to which the product is put, where it is grown, the methods used in its production and curing, or the variety. The principal types of tobacco and the relative importance of each type in the United States as measured by the average amount grown are shown in the following table:

TYPE OF TOBACCO	POUNDS
Cigar leaf . . . . .	200,000,000
Dark export (fire-cured) . . . . .	215,000,000
Maryland Eastern Ohio export (air-cured) . . . . .	22,000,000
Dark manufacturing (air-cured) . . . . .	75,000,000
Burley . . . . .	210,000,000
Bright flue-cured . . . . .	230,000,000
Perique . . . . .	200,000

**316. General cultural methods.** The seeds, being quite small, are sown in hotbeds or cold frames, and the seedlings are transplanted to the field by hand or by machine. Transplanting is done during April, May, and June. The plants are set in rows which are from 3 to 4 feet apart and are spaced from 15 inches to  $3\frac{1}{2}$  feet apart in the row. Unless the soil is quite moist, watering is required at the time of transplanting. Cultivation should be continued as long as the size of the plants will permit. In order to force the full development of the leaves, the plants are topped by breaking out the crown, or the terminal bud, usually before the blossoms appear. Lateral branches and suckers also are removed.

When the plants have reached maturity they are harvested by cutting the stalk near the ground (Fig. 116) or by picking the leaves from the stalk as they ripen. The cut plants or the picked leaves are attached to sticks and hung in a specially constructed barn for curing, a highly important process. The tobacco may be cured without the use of artificial heat (air-curing) (Fig. 117), by the use of open fires on the earthen floor of the

barn (fire-curing), or by heat radiated from hot pipes running through the barn (flue-curing). The yield of cured leaf in the several districts ranges from seven hundred to two thousand pounds per acre. A large number of more or less distinctive varieties are grown in these districts.

**317. Cigar leaf.** This class of leaf is used in the domestic manufacture of cigars. The bulk of the crop is produced in the states of Kentucky, Connecticut, Massachusetts, New York,



FIG. 116. Tobacco suspended on slats to be taken to the curing shed

Pennsylvania, Wisconsin, Ohio, and Florida. In the wrapper-leaf districts of New England and Florida, and, to a lesser extent, in the binder-leaf and filler-leaf districts of the other states mentioned, intensive methods of fertilizing, growing, and handling the crop and relatively large yields and high prices prevail. The wrapper-leaf soils are fine sands and sandy loams, while the binder-leaf and filler-leaf soils are stronger sandy and light-clay loams, with more clay in the subsoil. With the exception of a portion of the wrapper crop, the tobacco is harvested by cutting the stalk, and little or no artificial heat is used in curing. All cigar tobacco, after curing, must undergo an active process of

fermentation to develop the desired qualities, such as the aroma. The growing of high-priced wrapper leaf under cloth and slat shades in Connecticut and Florida represents a highly intensive system of farming.

**318. Manufacturing types.** These include tobaccos used in all domestic manufactures except cigars. The two leading types are the Burley, grown on the fertile soils of the blue-grass region of Kentucky and adjoining areas of Indiana, Ohio, and West Virginia; and the bright flue-cured which is grown on the light, less fertile soils of southern Virginia and the Carolinas. Burley

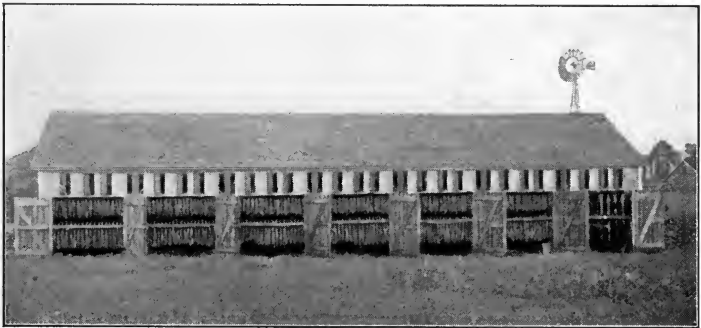

FIG. 117. Tobacco in the curing shed. (Photograph from United States Department of Agriculture)

is set rather close together in the row and the plants are topped high, so as to obtain a thin, light leaf. Commercial fertilizers are not required. The crop is harvested by cutting the stalk. Burley is an air-cured type. The flue-cured type is set further apart in the row and is topped rather low. Large quantities of commercial fertilizers are used in growing the crop. The crop is harvested either by cutting the stalks or by picking the leaves as they ripen. The crop is cured entirely with artificial heat. Burley and flue-cured leaf are mild tobaccos much in demand for the manufacture of chewing and smoking tobaccos and of cigarettes. The flue-cured type is also exported in large and increasing quantities.

Large quantities of dark air-cured tobaccos (Fig. 117), used both for domestic manufacture and for export, are grown in

Kentucky, Tennessee, and Virginia. Aside from the fact that the tobacco is air-cured, the methods of production are about the same as for the fire-cured export types.

**319. Export types.** The distinctive export types are the dark fire-cured tobaccos of western Kentucky and the adjoining counties of Tennessee, central Virginia, Maryland, and eastern Ohio. The fire-cured leaf is thick, heavy, dark in color, and strong, and is grown on rather heavy loam soils. In transplanting to the field the plants are set far apart, often in squares, and are topped low. The tobacco is harvested by cutting the stalk. In curing, open fires are made on the floor of the barn so that the smoke comes in contact with the tobacco, imparting to it the odor of creosote. Maryland tobacco is grown on light sands and sandy loams, and the leaf is mild and light in body and color. Cultural methods resemble those of the cigar-leaf and Burley districts.

**320. Soil depletion.** It is generally supposed that tobacco culture exhausts the fertility of the soil more rapidly than do other farm crops. In many tobacco-growing regions little rotation of crops is practiced and too little attention is given to replenishing the soil. Before farmers had learned how to rotate their crops and to use commercial fertilizers as successfully as they now do, the tobacco soils of some districts became so exhausted that tobacco growing was discontinued and the land planted to other crops or allowed to become covered with weeds or timber. Any one-crop system of farming depletes the soil, especially under such constant tillage and clean culture as are practiced in growing this crop, and tobacco has furnished an excellent illustration of the results of such farming. Proper rotation of crops, in which such legumes as clover and cowpeas are important, and the replenishment of the soil by the introduction of organic matter by plowing under green crops and barnyard manure, will bring good returns in an increase of the tobacco yield.

## QUESTIONS AND PROBLEMS

1. How does the tobacco crop rank in value among the crops of the United States? among the crops of the world?
2. Why has tobacco growing become such a specialized industry?
3. What are the three general classes of tobacco?
4. Discuss the principal types of tobacco grown and the relative importance of each type.
5. How is the finest quality of wrapper leaf produced?
6. Where is export tobacco produced?
7. What are the principal manufacturing types of tobacco, and where is each produced?

## REFERENCES

- DUGGAR, J. F. *Southern Field Crops*. The Macmillan Company.
- FREAR, WILLIAM, and HIBSHMAN, E. K. Production of Cigar-Leaf Tobacco in Pennsylvania, *Farmers' Bulletin 416*, United States Department of Agriculture.
- GARNER, W. W. Tobacco Culture, *Farmers' Bulletin 571*, United States Department of Agriculture.
- GARNER, W. W., BACON, C. W., and FROUBERT, C. L. Research Studies on the Curing of Leaf Tobacco, *Bulletin 79*, United States Department of Agriculture.
- MATTHEWSON, E. H. Tobacco Marketing in United States, *Bulletin 286*, Bureau of Plant Industry, United States Department of Agriculture.
- SCHERRFIUS, W. H. Tobacco Improvement, *Bulletin 139*, Kentucky Experiment Station.
- SCHERRFIUS, W. H., and WOOSLEY, W. H. Cultivation, Curing, and Marketing of Tobacco, *Bulletin 129*, Kentucky Experiment Station.

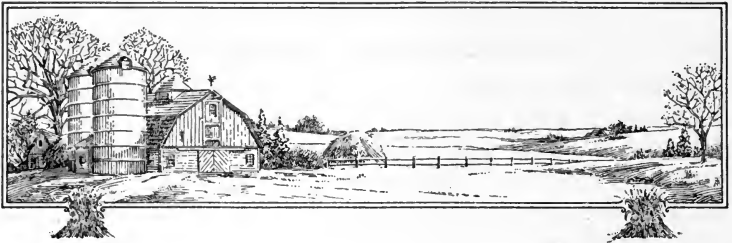

## CHAPTER XXII

### SILOS AND SILAGE

**321. Preserving summer feed for winter use.** With the exception of ripened grain, all foodstuffs lose much of their distinctive flavor and value when dried. Hay is never so nutritious as a feed as the green grass from which the hay is made. Even the ancients sought to make June feed conditions in January by preserving the green, succulent material in underground pits. The early efforts to preserve green feed, however, were only moderately successful, because the farmers in those days knew nothing of bacteria and how to use them. We may now keep feed green almost as easily as we preserve hay or dried feed. The *silo* is the receptacle in which green feed is preserved, and *silage*, formerly called *ensilage*, is the material preserved.

**322. Green and dried fodders compared.** If the curing process is carried on without the loss of leaves and the finer parts of the plant and without any fermentation, the cured feed will be practically as completely digested as it would have been if fed green. But under ordinary farm conditions hay cannot be made without a material loss of leaves and finer parts, and seldom without fermentation. An experiment<sup>1</sup> showed that red clover lost 18 per cent of its protein in the process of curing under the best farm conditions, 23 per cent under fairly good conditions, and more than 49 per cent when the weather was bad. Moreover, green foods are much easier to masticate than

<sup>1</sup> Kellner, *The Scientific Feeding of Animals*, p. 122.



are the same materials dried. A German experiment<sup>1</sup> showed that the horse expended one third more energy in chewing hay than was required to masticate similar foodstuffs in a green state. This is one reason why stock do so much better on pastures than on hay. Another important reason is that the stock relish green feed better than cured feed, and therefore eat more.

### 323. How silage keeps.

It was difficult at first to make people believe that a green material like corn or sorghum would keep in a silo when they knew it would decay if thrown into a pile in the open air. But a silo is almost air-tight (Fig. 118), and, after the silage has settled, little air reaches it. Excluding most of the air, however, is not the only condition necessary to the preservation of silage. A certain amount of acid must be present to

preserve or pickle the feed. While there are a number of acids produced in silage, there are only two with which we are particularly concerned — lactic acid, the principal acid of sour milk; and acetic acid, the principal acid of vinegar. These acids preserve the silage in much the same way that vinegar preserves pickles. To produce these acids there must be present in the materials put into the silo either sugar or substances



FIG. 118. Two types of cylindrical silos

The silo at the left is constructed of cement and was built inside of forms. The silo at the right is made of wooden staves held in place by iron rods

<sup>1</sup> Kellner, *The Scientific Feeding of Animals*, p. 88.

which may be converted into sugar. Very soon after forage has been put into the silo the sugar is acted upon by bacteria and is, in part at least, converted into acid. One may ask why it is necessary to exclude the air if the acid preserves the silage.

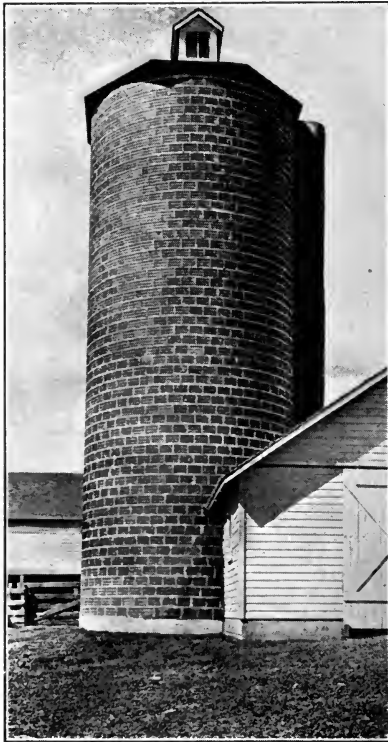

FIG. 119. A hollow-tile silo

When air is admitted, the acid is destroyed by molds which feed upon it. With the acid destroyed, the bacteria that cause decay, known as putrefactive bacteria, attack the protein and cause the silage to spoil. This may explain why clover, alfalfa, cowpeas, and soy beans do not keep well in the silo. These materials probably do not contain enough sugar to produce the acids required to preserve them. These legumes keep well when mixed with corn, sorghum, or other materials containing sugar.

**324. The advantages of the silo.**<sup>1</sup> A well-managed silo makes it possible for its owner to secure many important advantages. More feed can be stored in a given space in the form of silage

than in the form of hay. The space required to store one ton of hay will hold eight tons of silage. An acre of corn can be placed in the silo at less cost than the same area can be husked and shredded. Crops can be put into the silo in weather that is

<sup>1</sup> Adapted principally from *Farmers' Bulletin 556*, United States Department of Agriculture.

not suited to making hay or curing fodder. There is less loss of food material when a crop is thus stored than when it is cured as fodder or hay. Silage is very palatable and like other succulent feeds may have a beneficial effect upon the digestive organs. Good silage properly fed is all consumed; hence there is less waste in feeding it than in feeding dry fodder. Corn silage is a more efficient feed than is corn fodder. More stock can be kept on a given area of land when silage is the basis of the ration than when corn fodder or hay is the basis. Silage is the cheapest and best form in which a succulent feed can be provided for winter use. Silage can be used more economically than soil-crops to supplement pastures because it requires less labor. Converting the corn crop into silage clears the land early in the autumn, thus leaving it ready for another crop.

### 325. Silos and crop limits.

The silo extends the northern limits of the corn belt because it is possible to mature corn sufficiently to be put into the silo where it will not mature sufficiently to be husked or field-cured. In the northern part of the corn belt larger and more productive varieties can be grown for the silo than for field-curing. In dry climates and in dry seasons it is possible by means of the silo to preserve corn, kafir, and sorghum in good condition. If allowed to stand, the plants dry up before they are mature, and are largely wasted.

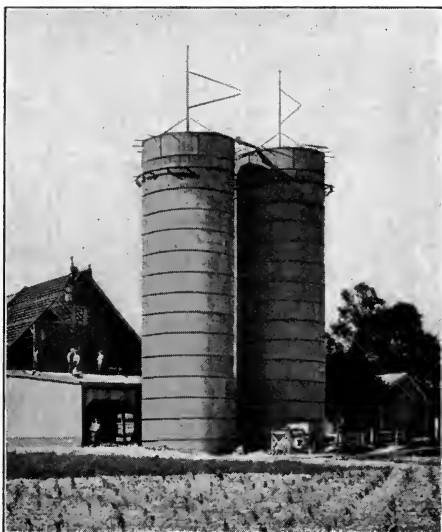

FIG. 120. Monolithic concrete silos

These silos are built solid in concrete forms, often with water tanks on top, as in the silos here shown

**326. Silage crops.** Most green plants can be preserved in the silo if they contain sufficient sugar to produce the acids required to preserve them, but hollow-stemmed plants, as wheat, rye, oats, and barley, and the legumes, such as alfalfa, clover, cowpeas, and soy beans, when siloed alone do not keep well. Corn is

the principal silo crop because it produces a high yield, matures at a suitable time, is easily made into silage, and keeps well. In the subhumid regions, sorghum, kafir, and milo are used extensively as silage crops and with very satisfactory results. In these regions the sorghums produce larger yields than corn and remain longer in the proper stage for siloing. When properly made, sorghum silage is no more acid than corn silage and is greatly relished by stock.

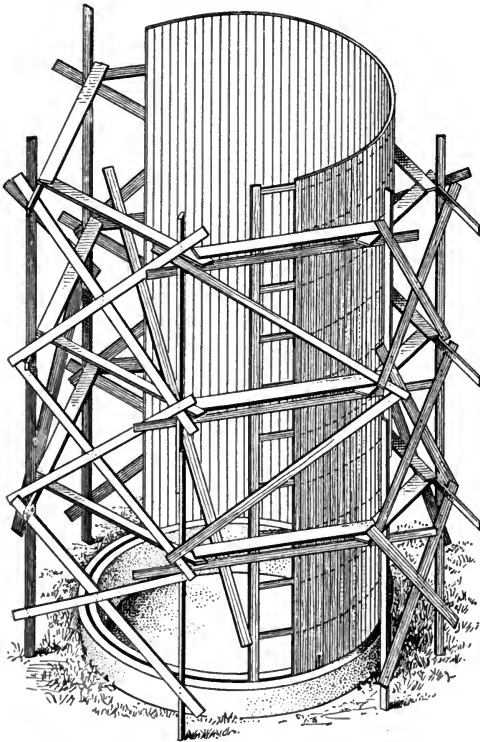

FIG. 121. The construction of a wooden silo

**327. Essentials of a silo.** The walls of the silo must be as nearly air-tight as possible and should be perpendicular and smooth so that the silage may settle easily and evenly. The silo should be strong enough to withstand the pressure of the silage and of heavy winds. The silo may be constructed of wood (Figs. 118 and 121), iron, tile (Figs. 119 and 122), brick,

stone, concrete (Fig. 120), or cement (Fig. 118). If the inside walls are perpendicular and smooth and the air is excluded, the silage will keep as well in one kind of material as in another. Other important considerations are cost and durability.

**328. Feed the silage when fresh.** As soon as silage is exposed to the air, at the ordinary temperature, molds begin to grow, and in a short time a distasteful flavor and a disagreeable odor develop, due to the decay of the protein of the silage. If the weather is too cool for molds to grow, the silage dries out and animals do not eat it with a relish. Silage may be exposed to the air one day at any season without injury, and in winter for several days. For sheep, silage should not be exposed more than a day if this can be avoided, for sheep have very discriminating appetites. For cows in milk two days' exposure should be the limit under ordinary conditions, and for horses the silage should always be fed perfectly fresh.

It is important, therefore, that the diameter of the silo, which determines the amount of silage exposed to the air, be adjusted to the size of the herd to be fed. To keep the surface silage fresh, at least 2 inches should be fed daily in winter, 3 inches in early fall and spring, and 4 or 5 inches in midsummer. The surface exposed in a round silo varies as the square of the diameter. Thus, the area exposed in a silo 20 feet in diameter is four times the area exposed in a silo 10 feet in diameter, and four times as many animals will be required to eat the silage rapidly enough so that it will always be fresh on the surface.

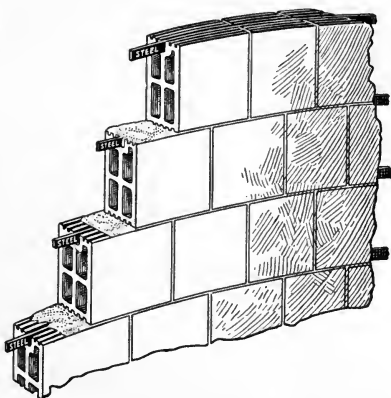

FIG. 122. Tile silo construction

Showing how the hollow tile are laid and how the steel rods hold them together; also mortar is placed between the layers of tile

**329. Proportions and size of silo to use.** The quantity of silage required and diameter of silo adapted to herds of different size are given in the following figures :

NUMBER OF COWS OR STEERS	FEED FOR 180 DAYS	FEED FOR 240 DAYS	DIAMETER OF SILO
	<i>Tons</i>	<i>Tons</i>	<i>Feet</i>
8	29	48	8
10	36	48	10
15	54	72	10
20	72	96	12
25	90	120	14
30	108	144	16
35	126	168	16
40	144	192	18
45	162	216	18
50	180	240	20
60	218	288	22
70	252	336	22
80	288	384	22
90	324	432 <sup>1</sup>	22
100	360	480 <sup>1</sup>	22

**330. The capacity of round silos.** The number of days that silage will need to be fed varies in different regions, on different farms in the same region, and on the same farm in different seasons, but the safe plan is to estimate the maximum time required, and build the silo to meet this demand. On most farms one hundred and eighty days will be the limit of the silage-feeding period, although on some of the best-managed dairy farms silage is fed every day in the year. A cubic foot of silage weighs from twenty to sixty pounds, according to the crop from which it is made, the amount of moisture it contains, and the depth of the silo. In computing the capacity of silos silage is usually estimated to weigh forty pounds per cubic foot.

<sup>1</sup> Where more than four hundred tons of silage are required, the use of two silos is generally advisable.

## CAPACITY OF THE ROUND SILO IN TONS

HEIGHT	INSIDE DIAMETER					
	10 feet	12 feet	14 feet	16 feet	18 feet	20 feet
	<i>Capacity in Tons</i>					
20 feet	26	38	51			
22 feet	30	43	59	77		
24 feet	34	49	67	86	110	
26 feet	38	55	75	97	123	152
28 feet	42	61	83	109	137	169
30 feet	47	67	91	119	151	187
32 feet	51	74	100	131	166	205
34 feet	56	80	109	143	181	224
36 feet	61	87	118	155	196	243
38 feet	66	94	128	167	212	262
40 feet	70	101	138	180	228	282
42 feet	74	109	148	193	244	300
46 feet			170	222	277	340
50 feet					310	382

**331. The height of the silo.** The deeper the silo and therefore the greater the pressure of the silage, the more completely the air will be excluded and the better the silage will keep. With the old-fashioned chain elevator it was not feasible to lift silage to a greater height than thirty feet, but with the modern blower elevator silage can be blown to a height of fifty or more feet. A convenient rule is to estimate the height of the silo at from three to three and one-half times its diameter. Silos of medium size should be between 30 and 40 feet high, and those of large diameter should be 40 or 50 feet high.

**332. What a silo costs.** A silo costs from \$2.50 to \$5 for each ton of capacity, according to the size, the materials used, and the conditions under which it is erected. This means that a 100-ton silo will cost from \$250 to \$500, and it will hold the forage ordinarily grown on 10 or 12 acres.

**333. When to cut crops for silage.** To secure the maximum yield of digestible materials it is necessary to allow corn to become reasonably mature before it is harvested, because the

greatest gain in digestible material occurs between the time when the corn is in the roasting-ear stage and the time when the grains become glazed. It is also true that corn which is reasonably mature makes a sweeter and more palatable silage.

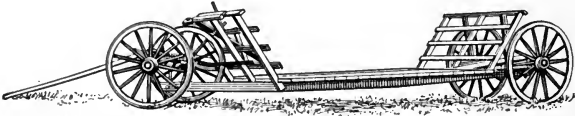

FIG. 123. Rack for hauling corn from field to silo

The best stage at which to cut corn for the silo is when the kernels are beginning to glaze and when the leaves below the ear are dry. If the corn should become too dry to pack well in the silo, about half a barrel of water should be added to each

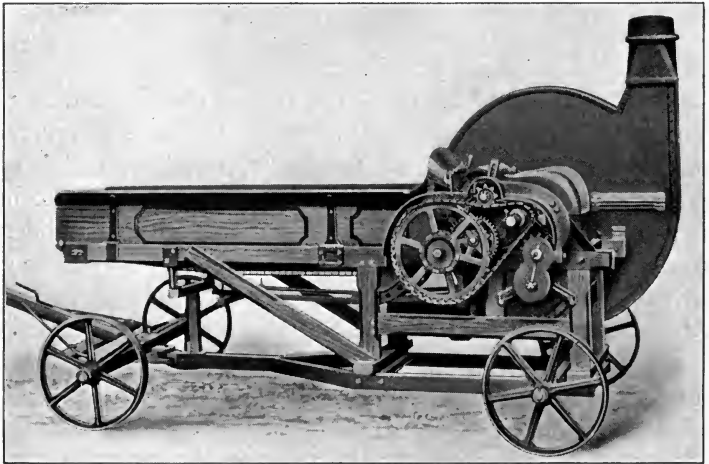

FIG. 124. Silage cutter and silo filler

wagonload of corn. The water is most effectively and conveniently added by running it into the blower as the corn is being elevated into the silo. Sweet sorghums should be mature when harvested, to make a silage of proper sweetness.



**334. Filling the silo.** The corn or sorghum may be harvested by hand or with a corn binder. Harvesting with a binder is both economical and convenient. A low-down rack or truck for hauling the green forage from the field will effect a large saving of labor (Fig. 123).

The green material should be cut into about half-inch lengths and elevated or blown into the silo (Fig. 124). The silo may be filled quickly, allowed to settle a week or ten days, and refilled; or it may be filled more slowly, allowing the silage to settle as the filling progresses. It is important to include as much silage as possible, not only to use the room to the best advantage but also to insure the silage keeping with the least loss. The most important operation connected with silage-making is the even distribution and packing of the material as the silo is filled. If the coarse, heavy pieces, such as the stalks and ears, are allowed to accumulate on the side of the silo farthest from the cutter, where they are naturally thrown, and the loose, light material, such as the leaves, tassels, and husks, is permitted to accumulate on the side next to the carrier or blower where it will naturally fall, the silage will settle unevenly and will not keep well. It will also lack uniformity in quality and cannot be fed without danger of underfeeding on one day and overfeeding on another. Numerous simple devices for scattering the material uniformly have been invented, but in any case a reliable man, and usually two men, should be stationed in the silo to mix thoroughly the heavy and light materials and to tramp the silage, especially along the walls.

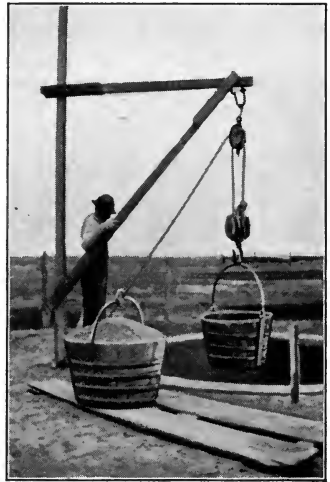

FIG. 125. Taking silage from the pit silo

**335. The pit silo.** In regions of limited rainfall and especially on soils with perfect drainage to the depth of twenty or more feet it has recently been found practicable to build in the ground a silo (Fig. 125) that serves every purpose of a much more costly structure aboveground. A large number of such silos are in use in western Nebraska, Kansas, Oklahoma, Texas, and eastern Colorado. The cost of a pit silo varies from a few cents to about a dollar for each ton it will hold. Labor, most of which is unskilled, is the chief item of expense in building a pit silo. Such a silo requires very little for upkeep and cannot

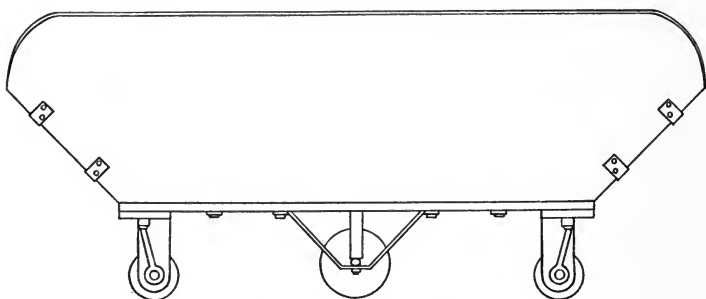

FIG. 126. A silage car

In feeding large quantities of silage a simple car which may be pushed close to the feeding troughs is of much assistance

be blown down. A blower or elevator is not required; therefore the cutter costs less and is operated at less expense than when filling a silo built aboveground. The silage will not freeze and keeps even better than in the aboveground silo. The principal disadvantage of the pit silo is the inconvenience in getting the silage out. The pit silo should have a cement curb extending from below the frost line to a few inches above the ground. The walls should be plastered with cement from three fourths of an inch to one inch in thickness and should be washed with a cement coat to make them water-tight and air-tight. A covering should be provided to keep out dirt, trash, farm animals, and children, and also to provide for the circulation of air within the silo.

**336. Amount of silage to feed.** Silage is a good feed at any season of the year, but it is especially valuable in winter when farm stock are without green feed (Fig. 126). It is for winter feeding what pasture grass is for summer feeding. The amount that may be fed daily to different classes of farm animals is approximately as follows :

KIND OF STOCK	POUNDS
<i>Dairy Cattle</i>	
Cows (in full flow of milk) . . . . .	30-50
Cows (dry) . . . . .	20-30
Heifers . . . . .	15-20
<i>Beef Cattle</i>	
Breeding cows . . . . .	30-40
Two-year-olds . . . . .	30-40
Calves and yearlings . . . . .	15-30
<i>Fattening Cattle</i>	
First stage of fattening . . . . .	25-30
Middle stage of fattening . . . . .	15-20
Last forty days of fattening . . . . .	10-15
<i>Horses</i> <sup>1</sup>	
Brood mares . . . . .	20-30
Idle horses . . . . .	15-20
Yearlings . . . . .	10-15
<i>Sheep</i>	
Breeding ewes . . . . .	3- 4
Fattening lambs . . . . .	2- 3
Fattening wethers . . . . .	3- 4

#### QUESTIONS AND PROBLEMS

1. Compare green fodder and dry fodder as feed.
2. Give a summary of the advantages of the silo.
3. Compare the principal silage crops, giving reasons why some are better than others.
4. How long may silage be exposed to the air without injuring its feeding value?
5. Why is it not profitable for the owner of two or three cows to use a silo?

<sup>1</sup> Silage is not a safe feed for horses unless it is perfectly fresh and free from mold.

6. How many more cattle will be required to eat the silage that should be fed each day from a silo 20 feet in diameter than from one 10 feet in diameter?
7. What are some of the most important reasons for securing an even distribution of the silage as the silo is being filled?
8. When should corn be cut for the silo?
9. When should sweet sorghum be cut for silage?
10. How much silage may be obtained from a fifty-bushel corn crop?
11. How does the pit silo compare with the aboveground silo in construction, use, and value?
12. How much silage should be fed daily to a yearling calf? to cows in full flow of milk? to idle horses? to fattening lambs?
13. Explain how silage keeps?
14. Why will silage made from legumes not keep so well as that made from corn or sorghum?
15. Why will silage made from hollow-stemmed plants not keep well?

#### EXERCISES

1. Compute the capacity of a silo required to feed a herd consisting of 10 dairy cows in milk, 5 dry cows, 6 yearling heifers, and 7 calves, and determine the largest diameter of silo that would be practicable for such a herd.
2. Compute the size of silo required for a herd of 20 beef cows, 18 two-year-old steers, 30 yearling heifers and steers, 25 calves, 30 breeding ewes, and 10 idle work horses. What is the largest diameter that could be used? What diameter and what height would you recommend? Would it be wiser to use one or two silos for this number of stock? How many acres of corn should be planted to supply the amount of silage required for this herd? How many acres of sorghum? How many acres of kafir? What would it cost to fill the silo with corn silage for this herd?
3. What is the capacity of a silo 30 feet in height and 18 feet in diameter? How many cows would such a silo feed for one hundred and eighty days?
4. What are the types of silos in use in your county? What is the significance of the fact that almost all these silos are of recent construction? What do silo owners think regarding the value of silos?

## REFERENCES

- Cement Silos, *Farmers' Bulletin 405*, United States Department of Agriculture.
- Cost of Filling Silos, *Farmers' Bulletin 292*, United States Department of Agriculture.
- Effect of Silage on Flavor and Odor of Milk, *Farmers' Bulletin 267*, United States Department of Agriculture.
- The Octagonal Silo, *Farmers' Bulletin 190*, United States Department of Agriculture.
- The Plaster Silo, *Farmers' Bulletin 469*, United States Department of Agriculture.
- Losses in the Silo, *Farmers' Bulletin 133*, United States Department of Agriculture.
- Reinforced Brick Silo, *Farmers' Bulletin 457*, United States Department of Agriculture.
- Silage for Horses and Hogs, *Farmers' Bulletin 103*, United States Department of Agriculture.
- Silage from Frosted Corn, *Farmers' Bulletin 309*, United States Department of Agriculture.
- Silage in Place of Hay for Dairy Cattle, *Farmers' Bulletin 222*, United States Department of Agriculture.
- Silage Making, *Farmers' Bulletin 316*, United States Department of Agriculture.
- Sorghums for Silage, *Farmers' Bulletin 334*, United States Department of Agriculture.
- Soy Beans for Silage, *Farmers' Bulletin 514*, United States Department of Agriculture.



## CHAPTER XXIII

### THE ORCHARD CROP

An orchard soil should possess opposite qualities in proper proportions. It should be free and firm; dry and moist; light and heavy, and the bottom should be of the same nature as the top. — THEOPHRASTUS

**337. Origin of the apple.** The apple is our most important fruit. Native to southeastern Europe and southwestern Asia, it has now spread by domestication to practically all the temperate regions of the civilized world. From a sour, wild fruit, scarcely better than the wild crabs of the United States, it has been improved by man until we now possess several thousand varieties, ripening at different seasons, suited to various soils and climates, and satisfying our many tastes and purposes.

**338. The tree fruits.** The United States is the leading apple-producing country of the world. In a favorable year our apple crop has a value of approximately \$100,000,000. New varieties are constantly being originated, and some of these are better suited to special purposes or better adapted to new localities.

The peach ranks next to the apple in importance, having a value of from one fourth to one third that of the apple. It probably originated in China. It was early introduced into Europe by way of Persia. The peaches of the United States were first brought from the orchards of Europe, but in recent years new types have been introduced from China.

The orange ranks third in importance among our tree fruits. It was probably native to Indo-China, but is now grown in many

semiotropical sections. The orange was introduced into the United States from southern Europe. The so-called "native" oranges of Florida are no doubt trees which ran wild from oranges introduced by the early Spanish explorers.

The plum ranks fourth in importance. Our older varieties, such as prunes, damson and egg plums, were introduced from Europe. In recent years another species, the Japanese plum, has been introduced from the Orient. Within the last fifty years



FIG. 127. An olive orchard in California

we have domesticated some of our native wild plums, securing such varieties as Wild Goose, De Soto, and Wayland.

Pears and cherries, both native to Europe, follow in order of importance. Other fruits, as the date and the olive (Fig. 127), have been introduced and, though not widely grown, are important.

**339. Orchard regions of the United States.** The principal orchard regions of the United States are the gravelly soils of New England and New York; the Blue Ridge foothills and southward; the sandy soils of New Jersey; the regions about the Great Lakes; some of the valleys of the West and Northwest,

such as the Gunnison, Grand Junction, Hood River, Rogue River, Bitter Root, North Yakima, Wenatchee; the silt loam or loess soils of the hills overlooking the Mississippi River and its tributaries; the red, gravelly clay loam of the Ozarks in Missouri and Arkansas; and the deep loam of some of the prairie states and the orange districts of Florida and California.

**340. Climate determines the type of fruit to grow.** The climate is the most important factor in determining the location of an orchard. Each kind of fruit has a northern limit, above which the winters are too severe for it to live; and most have a southern limit, below which it may become too hot for it to thrive. The Baldwin and Greening apples, for example, thrive best in the Northern states from New England to Michigan, while the Ben Davis and Winesap reach their best development from Virginia westward through Missouri and Arkansas. Humidity also is an important factor. Apples of the Newtown Pippin type are well adapted to the Atlantic and Pacific coast states, while the Duchess and kindred varieties reach their best development in the interior, where the climate is drier. Sweet cherries reach their best development in a moist climate like that of the coast regions and the Great Lakes. The sour cherries thrive best in the drier, continental climates of the Mississippi Valley states.

**341. Orchard soils.** Orchards grow well in many different regions, but it does not follow that any good agricultural soil is adapted to fruit trees. Aëration of the soil is necessary for the proper development of fruit trees, because their roots require more air than do the roots of most other cultivated plants. "Fruit trees do not like wet feet." Therefore the soil for an orchard should drain to a greater depth than is required for grains, grasses, or other farm crops, and must not be water soaked for any great length of time at any season of the year. A good orchard soil should be loose, porous, and mellow, so that the water penetrates readily and to great depth. In the estimation of many orchardists the subsoil is of more importance than the surface soil. A heavy clay subsoil or a hardpan is



always to be avoided. Sand or gravel in the soil and the sub-soil is favorable. Some clay loams may have very little visible sand or gravel and still drain sufficiently for fruit trees. The sand may be very fine or the soil may contain much organic matter to a good depth, thus insuring ample drainage.

**342. Fertility of orchard soils is of lesser importance.** The fertility of orchard soils is less important than drainage and aëration. A sandy soil that will not produce a large crop of corn or wheat may bear very good orchards, particularly if green-manure crops are occasionally grown among the trees and plowed under.

Fruit trees root deeper and feed from a greater soil area than do most other crops. The growing season of orchard trees is longer than for other crops, which means that they have a longer period in which to store up plant food. Furthermore, the leaves of the trees as well as the shedding bark and improperly developed fruit are annually returned to the soil, as are the weeds or other plants which grow under the trees. Only the salable fruit is removed, and it contains considerably less plant food than is removed by a crop of corn. It should not be understood, however, that fertility is not desirable in orchard soils. Other things being equal, a fertile soil is always to be preferred, and in any case attention should be given to maintaining the fertility of the orchard.

**343. The orchard site.** In choosing the location for an orchard, careful consideration should be given to such matters as slope, elevation, prevailing winds, and proximity to bodies of water. In a climate likely to be foggy at times, as parts of New England, a south slope is preferred, because the sunlight is insufficient on any other slope properly to develop the tree or ripen the fruit. In the foggy regions of Europe fruit trees are frequently grown along the south side of a wall to secure all the sunlight possible. In tropical countries some plants must be protected against excessive light (Fig. 128); while in a climate of intense sunshine like that which prevails in the Middle States a north or east slope is preferred, in order to

prevent sunscald of the trees and fruit and to decrease the danger of injury from frosts by retarding the opening of the fruit buds in the spring. In comparatively level districts, orchards should be located on the higher ridges.

**344. Air drainage.** In some localities air drainage is as important as water drainage. Cold air is heavier than warm

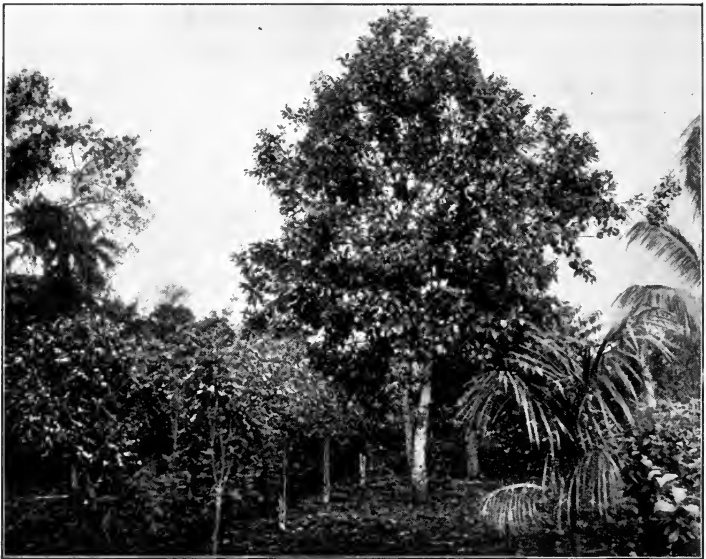

FIG. 128. Shading delicate plants

A Cuban grove, in which coffee (in flower) and tobacco are grown in the shade of orange and palm trees

air, and it drains to the lowest level just as water flows to the lowest level. Frosts are more common in low places, because the heavier, cold air has settled there. Consequently, orchards should not be planted in low, frosty places. In hilly regions the bleakest points may expose the orchard to winds that are too severe, and in such localities the sheltered slopes and valleys are preferable, especially if a still lower ravine or river bed is adjacent to drain off the cold air on frosty nights. The depth

at which cold air will stand in low places depends upon the area from which cold air drains into it, just as the depth of the water in a lake or river depends upon the drainage area of the basin.

**345. Bodies of water.** Bodies of water, if large or deep, temper the climate of the surrounding region. The water warms slowly in spring, thus retarding the opening of the buds and lessening the danger from late frosts. Also, the water cools slowly in autumn and prevents early frosts that might do serious damage to the ripening fruit. Such influence is most marked on land adjoining the ocean, and gives what is known as a maritime climate, comparatively free from abrupt changes in temperature. Lakes and rivers exert a similar influence, although extending over a much smaller area. The western part of Michigan, for example, is a notable peach region, because the prevailing winds have been tempered in passing over Lake Michigan. On the opposite side of the lake peach growing is not so successful, because the prevailing winds have passed over the land of Wisconsin instead of over the water of Lake Michigan.

**346. Varieties to plant.** Any orchard region is capable of growing several good varieties. Experience is the best guide as to what varieties to plant. For the home orchard the varieties should be chosen to give a succession of fruit. The collection should include one or two trees each of early varieties, but the main orchard should consist of the winter varieties. Commercial orchards should consist of the standard varieties that are known to be adapted to the region and have a well-established place on the market.

**347. How to prepare the land.** The preparation of the land for planting fruit trees is similar to the preparation of a seed bed for wheat or corn or cotton. The ground should be plowed deep, thoroughly harrowed, and put in condition, so that when the trees are planted they may be cultivated like any other tilled crop. Prevention of growth of weeds and conservation of moisture of the soil are important considerations in growing orchard trees.

**348. How far apart to plant.** The distance apart to plant depends upon the locality, the soil, and the variety. Trees that do not grow large and that wear out early may be planted much closer than those that grow larger and live longer. Sometimes fruit trees are planted closer than they should stand when fully grown, and when they have been bearing a few years and more room is required, each alternate tree is cut out.

**349. When to plant.** Trees may be transplanted in the spring or in the fall. In the milder climates, where trees are not likely to be injured by winter, fall transplanting is to be preferred because there is more heat in the ground then than in the spring, and new root growth is greatly stimulated by soil warmth. If the autumn is very dry, it is best to put off planting until spring.

**350. Shaping the root before planting.** All broken or badly injured roots should be cut back to healthy tissues. To avoid bending the roots in planting, all roots should be cut back to six or eight inches in length. Bending a root shuts off the flow of sap just as kinking a garden hose checks the flow of water. If the small fibrous roots are dry, bruised, or dead, they should be trimmed off, as they are not only worthless but prevent the soil from coming in full contact with the main roots.

**351. Setting the tree.** The tree should be placed in the ground as nearly as possible in the shape and at the depth at which it grew in the nursery. The hole to receive the tree should be broad enough to accommodate the natural spread of the root system. As the tree is held in the hole at the proper depth and in the proper position, the soil should be shaken from the shovel loosely so that it will sift in between the roots and leave them in their normal position. At the same time the tree should be shaken so that its roots will retain their natural spread instead of being bent down in an unnatural position. As soon as the lower roots are covered with a layer of soil, the soil should be pressed down firmly. Layer after layer of soil should be tramped firmly from the bottom of the hole to the top, and then a layer of loose soil should be spread over the surface to act as a mulch. Unless the soil is too wet and heavy for proper

tree planting, it is not likely to be made too compact. If left loose the roots will dry. The entire root system should be in close contact with settled soil. Watering the roots at the time of transplanting is likely to do more harm than good unless the soil is very dry. This is particularly true in clay loams.

**352. Shaping the top.** As soon as possible after the tree is planted, the top should be reduced to correspond to the cut-back root system, so that the branches will not evaporate more water than the limited root system can supply.

The apple, quince, pear, and American plum should have the branching system reduced about one half by cutting out superfluous branches and shortening the others. The peach, Japanese plum, and kindred trees should have all the side branches removed and the main trunk cut back to a point where it is desirable to have the tree form its branching

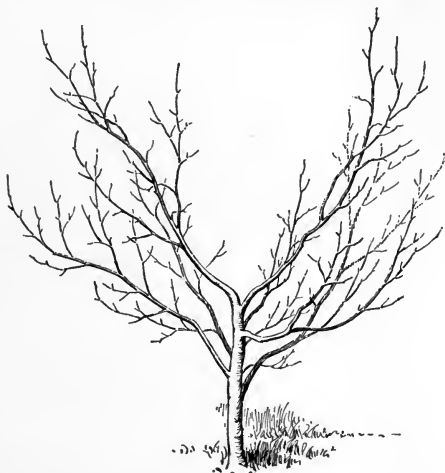

FIG. 129. An "open head" apple tree

Diagram from University of Missouri

system. This is called pruning to a single "whip." The cherry should be pruned least of all. If the young cherry tree has but few side branches, it will need no pruning. If the top is too large, one or two limbs may be removed. The branches should not be shortened, because the active buds of the cherry are near the end of the branch, while the buds next to the base are dormant and will start slowly if at all. The peach, however, pushes out new growth readily from any of its parts, even from the old limbs, and may be pruned as much as is required to keep it within proper limits.

**353. Pruning for open form.** The form of the tree is determined when it is young. The length of the bare trunk is determined by removing the lower branches to the height at which it is desired to have the head formed. The head of the tree should be given an open or a pyramidal form, in accordance

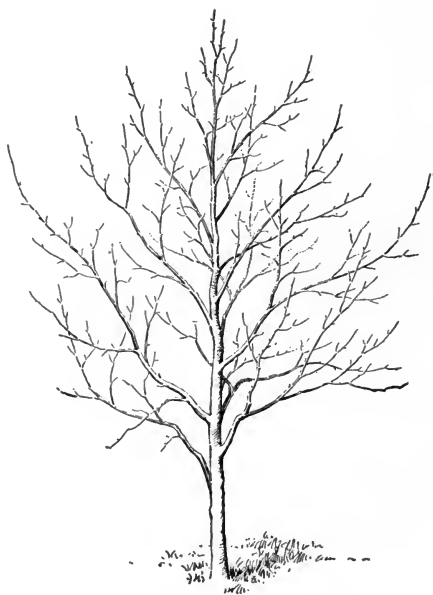

FIG. 130. A "central leader" apple tree

In this tree the central stem has been allowed to extend so that the whole top is pyramidal in form. Such a tree is favorable to regions of intense light (Diagram from University of Missouri)

with the climatic conditions under which the tree is to be grown. To secure the open-head, or vase, form the main trunk is cut off at the desired height, and from three to five side limbs are retained to spread out from the center at as near the same angle as possible. This form admits sunlight to the center of the tree and gives a short, broad tree that is easily pruned, sprayed, and managed, and from it the fruit may be conveniently picked (Fig. 129).

**354. Pruning for pyramidal form.** In the pyramidal form the tree is allowed to retain its

central trunk, or "leader," and side limbs are allowed to form symmetrically around the trunk. A few of the branches are removed from year to year to allow room for those that remain, but the natural symmetry of the tree is retained. The pyramidal form results in a taller tree, as shown in many of the varieties of pears. A dense head is maintained on pyramidal trees to serve as a protection in regions of intense sunlight (Fig. 130).

Whenever a large limb is to be removed, it should be cut close to the trunk, as the wound cannot heal quickly and the new growth cannot grow over a projecting stub. Wounds more than one-half inch in diameter should be painted with white lead and oil as a protection against disease and decay. The pruned tree will produce much of its fruit near its main body (Fig. 131), while the unpruned tree will shade its inner twig



FIG. 131. A well-shaped apple tree

growth and produce most of its fruit toward its periphery. In the latter case the tree will have much waste space and will be in greater danger from winds.

**355. How to make a tree bear fruit.** The growth of fruit trees consists of wood growth, or the formation of vegetative parts such as leaves and limbs, and fruit growth, or the formation of the fruit parts such as the flowers and the fruit itself. While a tree is making rapid wood growth and while its limbs are lengthening rapidly and many new leaves are being formed, the supply of sap and available plant food is used at the growing

points to support this vegetative activity. When this growth becomes less active, plant food begins to be stored. Some of this food is stored in the buds, and fruit buds may be formed, but fruit buds are not formed as long as all the food available to the tree is required for vegetative growth. Therefore some means must be used at times to hold the wood growth in check and to allow a part of the food to go to the development of the new fruit buds.

Pruning may stimulate or check wood growth, and therefore may hinder or help fruitfulness, according to the season of the

year in which it is done.

Winter pruning, which stimulates wood growth and keeps up the vigor of the trees, if carried to extremes retards fruitfulness. Summer pruning checks vegetative growth, by removing some of the leaves in which plant food is being elaborated, and stimulates the formation of fruit buds for



FIG. 132. Effects of failure to prune apple trees

the next year. By a proper practice of winter or summer pruning, wood growth and fruitfulness may be kept in proper balance; failure to prune results in a ruined tree (Fig. 132).

**356. Orchard cultivation — general.** Fruit trees, especially when young, require good cultivation. The soil should be plowed early in the spring and harrowed frequently during the season. The exact time to stop cultivating varies according to different conditions, such as climate, soil, and rainfall. Cultivation encourages rapid length-growth of the twigs and rapid thickening of the whole growing layer of the tree. As length-growth ceases this tender new tissue becomes stronger, harder, and more resistant to cold and other injurious agencies. This hardening



of the new growth and this adaptation to winter conditions is sometimes called ripening of the wood, and cultivation must cease in time for this ripening to occur before winter.

In the Northern states, where the autumn ripening period is short and the winter is cold, cultivation should usually cease in late June or early July. In the Southern states, where the autumn is long and the winter is mild, cultivation may continue throughout the summer, often until the fruit crop is mature.

Cultivation should cease earlier in wet seasons and in moist climates than in dry. In case of a drought, one of the best ways of enabling trees to mature their wood is to give good tillage to retain the soil moisture.

**357. Special features of cultivation.** The different species of fruit vary somewhat in the amount of cultivation required. The peach and the Japanese plum are rank growers and gross feeders. They make rapid annual growth and reach the bearing age early. They also remove annually from the soil a greater quantity of plant food and are less drought-resistant than other fruit trees. Their vigor is easily impaired, and their capacity to bear fruit is reduced by unfavorable conditions for growth. For these reasons peaches and Japanese plums should be given more thorough cultivation than is required for other fruits.

Pears and cherries are not gross feeders. They remove from the soil only about one third as much plant food as do peaches, and about one half as much as do apples. They are able to grow under less favorable conditions than other fruits and require less cultivation. Many growers prefer to cultivate cherry orchards and pear orchards only two or three years, or until the trees become well established, and then seed the land to grass or clover. Pear trees which make slow, firm growth, as when in a sod, are more resistant to blight than those which grow rapidly.

The apple and the American and European plums rank between the peach and the pear in their tillage requirements. They should be given good cultivation at least until they reach the bearing age. Usually they produce better if given good cultivation throughout their life. On deep, mellow, fertile soils they

will yield reasonably good results in clover sod or even in grass sod. The power of the apple to adapt itself to different degrees of tillage makes it suitable to a great variety of soils and systems of farming. Tilled orchards should have some kind of crop returned to the soil from time to time, to keep up the supply of organic matter. This may be accomplished by cultivation during the early part of the season and then by growing a green crop to turn under the following spring. Some of the crops used



FIG. 133. Students judging apples

for this purpose in the North are rye, crimson clover, and buckwheat, and in the South cowpeas or soy beans.

**358. When to pick fruit.** When fruit has been properly grown the problem of its proper use is of the next importance (Fig. 133). Early apples should be picked when their seeds begin to turn brown and before the fruit is mellow. The fruit can be handled with less bruising, and keeps better, if picked before it is mellow. Fall and early-winter apples should be picked as soon as they are fairly well colored. If, on account of hot weather in early autumn, they begin to drop badly before

they are well colored, they should be picked early enough to save waste, even though they are not well colored. Late-winter apples should be allowed to hang on the trees until they are full size and have good color. Apples, like other fruit, should be picked when dry, and should be kept as cool as is feasible without freezing. They should never be piled in the sun, but should be handled in the shade of trees or in a shed. If placed in a building, cooling ventilation should be secured.

Pears should be picked while they are yet hard, but when their skin shows by its yellowing tint that ripeness is approaching. They should be ripened in a cool, dark place, such as a cellar. They are of finer quality when ripe if each specimen is wrapped in paper as soon as it is picked. They should be ripened in boxes, baskets, or in thin layers on shelves. Perishable fruits like peaches, plums, and cherries should be picked when well colored but while they are firm.

#### QUESTIONS AND PROBLEMS

1. What are the most important orchard crops in the United States? in your locality?
2. What are the principal orchard regions of the United States?
3. In what ways do climate and location determine the kind of fruit to grow?
4. In growing orchards why is fertility of the soil of less importance than drainage?
5. What soils are best for orchards?
6. What precautions should be observed in choosing a location for the orchard? What are the most favorable orchard sites in your vicinity?
7. What kinds of fruits should be planted for the home-farm orchard?
8. Prepare a planting diagram for a home-farm orchard, indicating the number and kinds of trees and the distance apart they should be planted.
9. Write a series of directions for planting young apple trees.
10. What are the reasons for root-pruning when planting trees? Top-pruning?
11. Visit a neighboring orchard, select one tree as the basis for work, write a statement of what pruning the tree needs, and later, in class, compare results.

12. What is the relation of pruning to fruitfulness?
13. When and under what conditions should the orchard be thoroughly cultivated?
14. What precautions should be observed in picking apples and pears?
15. How is fruit stored in your locality? in commercial concerns? Can you suggest improved methods of storing fruit?
16. From what sources do the apples come that are sold in your markets?

### EXERCISES

1. Secure three similar apples and weigh them accurately. Place one where it is constantly exposed to the air of the schoolroom. With a cloth rub from another all of the oily material from the apple skin and place this apple beside the first, but rub it again each day. Cut the third apple into halves and place the pieces beside the other apples. Weigh the three apples from day to day, and determine and explain the relative loss in weight from each.

2. If a farmer near your school will coöperate, select an apple tree on his farm, prune and cultivate and spray it, and write a record of what you have done. Leave this record in a schoolbook for this purpose, and let each succeeding class follow the same plan, each class recording the result shown on the tree's production of apples. This plan may be adopted with profit for other kinds of trees if there is available opportunity for experimental work.

3. Transplant some fruit trees to the school grounds, even though they cannot remain there to grow permanently. Make sure that proper methods of planting and pruning are used.

4. Study fruiting branches of the various fruit trees cut in winter. Observe the difference between the large, blunt, globular, hairy fruit buds and the small, flat, pointed wood buds. Note the location of the fruit buds on the tree. Contrast the position of the fruit buds of the peach (on the long, new whips at the outer extremities of the limbs) with that of the fruit buds of the apple or pear (on the short fruit spurs farther back in the tree). Locate the fruit scars where apples or pears have been borne in previous years. (If a fruit reached maturity the scar will be large and prominent, while if the fruit dropped prematurely the scar will be smaller.) Can you tell on what years an apple or pear tree has borne fruit by observing the fruit scars on

the annual growths? Can you tell by the character of the fruit scar whether or not a fruit matured?

5. If there are fruit trees on the school grounds or on an available orchard, till the soil around the base of some of them, from the trunk to the outer spread of the branches. Observe the difference in growth of the tilled and the untilled trees.

6. **Fruit judging.** In exhibits fine fruit is usually shown on plates. In the case of apples, pears, peaches, and large tree-fruits, five specimens compose a plate. These should be labeled as to variety, and should be true to name. They should be typical of the variety, as it customarily develops in the region, and should be perfect specimens. Abnormally large specimens are not likely to be typical in form or color, and are apt to be coarse in texture and lacking in flavor.

Uniformity in size, shape, color, and other characteristics are important factors to keep in mind. Each specimen should be sound, free from bruises, free from insect or fungus injury, and should have the stem intact. The stem is as much a part of the fruit as is the skin. The specimens should not be polished. Fruit is usually judged on the basis of 100 for a perfect plate. The score card used in a state can usually be furnished by the agricultural college of that state. A general score card is given in Appendix A.

#### REFERENCES

- BAILEY, L. H. *The Pruning Book*. The Macmillan Company.  
CARD, F. W. *Bush Fruits*. The Macmillan Company.  
FLETCHER, S. W. *How to Make a Fruit Garden*. Doubleday, Page & Company.  
FULLER, A. S. *The Grape Culturist*. Orange Judd Company.  
*The Small-Fruit Culturist*. Orange Judd Company.  
GREEN, S. B. *Popular Fruit-Growing*. Webb Publishing Company.  
HUME, H. HAROLD. *Citrus Fruits and Culture*. Orange Judd Company.  
PADDOCK, W., and WHIPPLE, O. B. *Fruit-Growing in Arid Regions*. The Macmillan Company.  
WAUGH, F. A. *Plums and Plum Culture*. Orange Judd Company.  
*Fruit Harvesting and Storing*. Orange Judd Company.  
*Beginners' Guide to Fruit-Growing*. Orange Judd Company.  
*The American Apple Orchard*. Orange Judd Company.  
WICKSON, E. J. *California Fruits and How to Grow Them*. Dewey and Company.

- The Apple and how to Grow it, *Farmers' Bulletin 113*, United States Department of Agriculture.
- The Home Fruit Garden: Preparation and Care, *Farmers' Bulletin 154*, United States Department of Agriculture.
- The Apple in Cold Storage, *Farmers' Bulletin 48*, Bureau of Plant Industry, United States Department of Agriculture.
- American Varieties of Garden Beans, *Farmers' Bulletin 109*, Bureau of Plant Industry, United States Department of Agriculture.
- The Cold Storage of Small Fruits, *Farmers' Bulletin 108*, Bureau of Plant Industry, United States Department of Agriculture.
- Orchard Fruits in Virginia and the South Atlantic States, *Farmers' Bulletin 135*, Bureau of Plant Industry, United States Department of Agriculture.
- Orchard Green-Manure Crops in California, *Farmers' Bulletin 190*, Bureau of Plant Industry, United States Department of Agriculture.



## CHAPTER XXIV

### THE WOOD CROP

My prayers with this I used to charge —  
    A piece of land, not very large,  
Wherein there should a garden be  
A clear spring flowing ceaselessly,  
And where, to crown the whole, there should  
A patch be found of growing wood.  
All this and more the gods have sent  
And I am heartily content. — HORACE

**359. The importance of the wood crop.** Asia, North America, Europe, and Australia have approximately 7,417,187 square miles of forest lands, an area almost equal in extent to the total land area of North America. The extent of forest lands in South America and Africa is not known. Russia leads the nations in the extent of her merchantable forests; the United States ranks second; and Canada, third. The forest regions of the temperate zones are the most productive of high-grade, merchantable timber. The tropical regions produce a great variety of timber, much of which is very heavy and hard. It is valued highly for special purposes, but is not suitable for general structural material. The forests of the United States yield a higher grade of structural lumber than do the forests of any other country.

**360. The forest industry.** The forest industry at the present time ranks next to the strictly agricultural industries in volume and in the wealth produced. All great industries depend directly

or indirectly upon the products of the forests for some of their necessary supplies. There is no article, except foodstuffs and textiles, that is of greater importance to the welfare of civilization than wood and its products. Notwithstanding the fact that we are to-day using more steel and concrete in the industries than ever before, each year finds an increased demand for wood. In the United States we are using the timber three times as fast as it is being grown, our use of wood per capita being more than that of any other people. Under



FIG. 134. The farm wood lot

Such a wood lot adds both beauty and utility to the farm. (Photograph from United States Forest Service)

proper management, however, our forest lands are capable of producing all the timber that we shall need in the future.

**361. Forests of the United States.** The forests of the United States cover an area of about 859,375 square miles (or about one third of the total area), divided into five forest regions known by their geographic locations.

**362. The Northern forest region.** This region originally contained the highest grade of timber that has ever been cut. It was the home of the white pine, which established the reputation of the United States throughout the world as a forest region. The trees of the Northern forest are white pine, red pine, jack pine, spruce, fir, tamarack, birch, maple, beech, ash, chestnut, and hemlock.



**363. The central forest region.** This is frequently spoken of as the Central Hardwood Region of the United States.<sup>1</sup> This region has furnished and is still furnishing the trade with its hardwood timber. The trees of the central forest are white oak, black oak, red oak, hickory, chestnut, walnut, yellow poplar, cherry, ash, elm, maple, beech, locust, linden, and cottonwood.

**364. The Southern forest region.** The principal species of this region are the Southern yellow pine and the cypress, which are at the present time supplying the lumber for most of the trade east of the Missouri River. In this region the naval-stores industry<sup>2</sup> was developed, and this is still the most important region in the world for these products. The trees of the Southern forest are yellow pine, white oak, live oak, red oak, hickory, cypress, white and red cedar, gum, elm, and ash.

**365. The Pacific coast forest region.** The Pacific coast region produces the most wonderful tree growth in the world. The California Redwoods and the California Big Trees attain the largest size, and are the oldest known living trees. Some of these trees are thought to exceed four thousand years in age. This is the home of the Douglas fir, which at the present time yields a greater cut of lumber than does any other single tree. Pines and cedars are also important trees of this region. The trees of the Pacific coast forest are Douglas fir, spruce, larch, red cedar, hemlock, redwood, big tree, white and yellow pine, maple, birch, and alder.

**366. The Rocky Mountain forest region.** These forests are widely scattered, but much valuable timber is cut from them. The important trees in the region are yellow pine, Douglas fir, spruce, juniper, piñon pine, aspen, and cottonwood.

<sup>1</sup> "Hard wood" is the trade name applied to lumber cut from the broad-leaved species, such as oak, hickory, elm, cottonwood, and basswood. Lumber cut from the coniferous, or cone-bearing, species is known as soft wood.

<sup>2</sup> Under the name of "naval stores" are comprised all the resinous products and their derivatives that are gathered from coniferous trees. These are resin, turpentine, common pitch, brewer's pitch, tar, and oil of tar. See chapter on Naval Stores in *House Document 181*.

**367. Forests modify climate.** It is well known that forests reduce the wind velocity along the surface of the ground within their territory. The reduction of the wind velocity, in addition to equalizing atmospheric temperature, reduces the evaporation from the leaves and soil. The average humidity of the atmosphere within a forest is always much greater than in the open country. Forests are great conservers of moisture, because the roots open the soil and enable the rain or snow water to find a ready passage into the substratum, and the blanket of leaves and twigs over the surface operates as a sponge to absorb the moisture and to prevent surface run-off, thus insuring a more uniform flow of water in the streams throughout the year. This is a matter of the greatest importance in irrigable sections of the country, which must have a continuous supply of water throughout the growing season to mature the cultivated crops.

**368. Forests prevent floods.** The retardation of melting snows and surface run-off water is also a great factor in preventing floods during seasons of heavy precipitation. Otherwise, damage to property, erosion of soil, and possibly the loss of lives in the river valleys many miles from the source of rainfall or snowfall might result.

**369. State and national ownership.** About one fourth of the timberland of the United States has been set aside as state and national forests. The purpose of these forests is to insure a future supply of timber and to protect the agricultural and other interests within drainage basins of the streams that have their source within the regions covered by these forests. It is the work of the Forest Service, which has control of the national forests, to put into execution the regulations prescribed by the United States government for the cutting and handling of timber in these forests.

**370. Government and private forest policies.** Practical forestry demands that all materials within the forest be put to their greatest use for the greatest number of people concerned, and every mature tree that is not needed to protect the watershed should be cut and sawed into lumber to meet the needs of the home

builders, manufacturers, and other consumers. The policy of the private timberland owners, until within recent years, has been that of robbing the land of the standing timber without regard to a future crop, and the practice of leaving the dead timber and unused part of the trees on the land has resulted in



FIG. 135. Effect of thinning upon increased growth

In a dense stand trees grow more rapidly in height than in diameter. The central part of this section of a lodgepole pine tree grew while the trees were crowded. The outer part grew after thinning took place. (Photograph from United States Forest Service)

forest fires that have destroyed millions of acres of valuable growing timber. Many of the regions that once supported splendid forests are now barren wastes.

Lumbering is usually a wasteful operation, and under careless methods far more material is destroyed than is marketed. Under proper regulation, however, lumbering can be carried on

with a small amount of waste and with very little injury to the young timber, and the danger of fire following cutting can be entirely eliminated.

**371. Farm wood lot.** Of the 617,187 square miles of timberland held under private ownership in the United States, about one fourth is included in what is termed "farm wood lots," and is owned by the farmers throughout the agricultural regions of the United States. The proper handling of these wood lots is a matter of great importance in the economic management of the farms. The wood lots may consist of natural or planted timber. They occupy lands that are entirely accessible, and are as a whole more productive than much of the land within the forest regions. Under proper management these wood lots are capable of producing the highest grade of timber and may also produce a great deal of small material for constant farm use (Fig. 134).

**372. Management of the wood lot.** The object to be secured in the management of a wood lot is a full stand of growing timber of the highest possible grade. To accomplish this:

1. All inferior species and defective and diseased trees must be cut to make room for trees of greater value (Fig. 135).
2. All merchantable trees must be cut and removed as soon as they have reached financial maturity.
3. All open spaces made by the removal of trees must be planted with seeds or seedlings of desirable species as soon as possible after the ground has been cleared.

In the artificial wood lots where the catalpa, black locust, red oak, chestnut, or eucalyptus are growing, reproduction may be secured by stump sprouts, and in this case planting will be unnecessary. Frequently it is possible to save time in the rotation of a timber crop by planting under the mature trees with a shade-enduring species, such as the white pine, spruce, red cedar, and chestnut, several years before the mature trees are cut. When this method is practiced, great care must be exercised in cutting and removing the mature trees, in order to avoid injuring the young stand.

## QUESTIONS AND PROBLEMS

1. In what ways do the forests of the United States affect the industries of your own state?
2. What forest products used in this state are grown within your state boundaries?
3. What is the source of the timber shipped into your locality?
4. What is the acreage of timberland growing in this state?
5. What is the nature of your state forestry organization?
6. What steps has your state taken to protect and improve the stand of growing timber?
7. In what ways do forests conserve moisture?
8. In what ways do forests equalize temperature?
9. How many farmers of your school community have planted wood lots?
10. What materials are the wood lots of your own community producing?
11. What species of trees are best adapted to your state? to your locality?
12. If fence posts are worth 35 cents each, and if an acre will produce 2000 posts in 12 years, will it be profitable for the farmer to grow fence posts?

## EXERCISES

In a representative wood lot or native wooded area accessible to the school, select an acre as the basis of practical study.

1. Prepare a list of all the trees.
2. Measure the diameter of all the trees at the same height, and determine the average for each species.
3. Select an average sample tree of each of some of the important species, and if the tree may be cut, determine the following points: (1) the age of tree; (2) the volume of the trunk in cubic feet, and of the limbs in cords; (3) the rate of growth of trunk by decades, in cubic feet; (4) the stages of development in which these trees made the greatest growth in volume; (5) the average annual rate of growth per acre in cubic feet.
4. Mark trees that should be removed in making an improvement cutting.
5. Select one of the open spaces in the wood lot for underplanting, by the following methods: (1) seed-spot planting; (2) broadcast seeding; (3) planting seedlings of tolerant species.

## REFERENCES

- GRAVES, HENRY S. Principles of Handling Wood Lots.
- GREEN, S. B. Principles of American Forestry.
- The Wood Lot, *Bulletin 42*, Forest Service, United States Department of Agriculture.
- Forest Planting in Western Kansas, *Bulletin 52*, Forest Service, United States Department of Agriculture.
- A Primer of Forestry, *Bulletin 24*, Parts I and II, Forest Service, United States Department of Agriculture.
- The Maple Sugar Industry, *Bulletin 59*, Forest Service, United States Department of Agriculture.
- The Timber Supply of the United States, *Circular 97*, Forest Service, United States Department of Agriculture.
- Preservative Treatment of Fence Posts, *Circular 117*, Forest Service, United States Department of Agriculture.
- Suggestions to Wood Lot Owners in the Ohio Valley Region, *Circular 138*, Forest Service, United States Department of Agriculture.



## CHAPTER XXV

### PLANT DISEASES

**373. How plant diseases affect crops.** Farm crops are subject to diseases just as people are, and many diseases of plants are infectious, just as are many of the diseases of animals. The more generally a given crop is grown in a community, the more widespread and numerous the diseases of the crop become. The longer a crop is grown in a field without rotation, the greater is the number of diseases affecting the crop. Diseases have become so common among some of our important orchard and garden crops that systematic spraying is necessary to hold the diseases in check. The yearly loss in the United States from potato blight alone is estimated at \$36,000,000; from grain smuts, more than \$33,000,000; from grain rusts, nearly \$20,000,000; and from cotton wilt, no less than \$10,000,000.

**374. Diseases due to parasitic plants.** The most important plant diseases are caused by plant parasites, and these are the only ones which will be discussed at this time. Parasitic plants do not take food materials directly from the soil and air but live on other plants, and in so doing they often cause diseases of the plants on which they live. There are parasitic flowering plants, and parasitic bacteria and fungi.

**375. Parasitic flowering plants.** The dodder and the mistletoe are well-known parasitic flowering plants. The dodder is a yellowish, more or less twining plant which wraps itself around the stems of clover, alfalfa, and other plants. By means of rootlike

suckers it pierces these plants and extracts their juices for food. The plant attacked becomes stunted and the yield of clover and alfalfa is seriously reduced when fields are badly infested with dodder. Mistletoe (Fig. 136), well known from its widespread use at Christmas time, lives on the branches of trees. Its suckers penetrate the bark and extract its food. Mistletoe is a common pest on ornamental and forest trees throughout the South and Southwest.



FIG. 136. Mistletoe — a plant parasite

The leaves of the oak tree are young and small, and the bunches of mistletoe conspicuous.

(Photograph by Dr. W. L. Bray)

**376. Bacteria.** Bacteria are exceedingly abundant, occurring in the air, water, soil, and in bodies of animals. They are invisible to the naked eye. They may live singly or in groups in the substance on which they feed. They reproduce by dividing in two, the whole process often taking less than half an hour, so that under favorable conditions a small number of these plants may produce hundreds of thousands in a few hours.

Most bacteria are either harmless or beneficial, but some cause disease. Tuberculosis and typhoid fever are due to the growth of harmful bacteria in the human body; and the wilt of melons and cucumbers, the wilt of tomatoes and potatoes, the well-known pear blight (Fig. 137), and the crown gall common to apples, roses, alfalfa, and many other plants are well-known bacterial diseases.

**377. Fungi.** Fungi are also exceedingly abundant and are found living on decaying organic matter (saprophytes), such as leaf mold, rotting wood, and manure, and as parasites on living plants. They do not have true root systems, but masses of rootlike threads



(each mass being known as the mycelium), by means of which they secure their food. Many fungi produce secretions known as enzymes, which break down, or dissolve, the tissues of the plants in which they occur, thus making the food available to the fungus. Plants undergoing such changes generally become diseased. When the fungi reach maturity, they do not produce seeds as do the flowering plants, but small reproductive bodies called spores. The spores are not visible to the naked eye except in large masses; they are scattered by winds, water, insects, man, and by other animals, and when they fall in favorable places they grow.

Among the well-known fungous parasites are those producing rusts and smuts in grain, smut in corn, scab on potatoes, scab on apples, and the brown rot of peaches. Mushrooms, puffballs, and bread mold are common fungous saprophytes.

**378. Diseases controlled wholly or in part by pruning.** Pear blight is one of the best-known bacterial diseases of plants. It attacks pear, apple, and quince trees. Its symptoms appear as sudden wilting and blackening of the blossoms; after the flowering time the tips of the twigs blacken in from two weeks to a month. The disease spreads to the branches and to all the spurs carrying flower clusters. Sometimes, particularly in pears, the disease travels down into the larger limbs and the trunk of the tree, causing body blight and, eventually, the death of the whole tree. Frequently the fruit is affected and shrivels up. Insects, especially bees, that have come in contact with the bacteria, carry them on their feet, body, and mouth parts to the blossoms, where the growth and spread of the disease are rapid. The bacteria live over winter in diseased branches which serve as a source of infection the following spring. Pear blight may be controlled by carefully removing and burning all infected

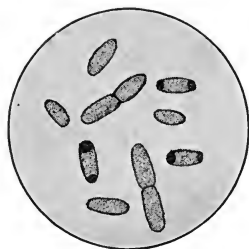

FIG. 137. Bacteria which produce pear blight  
Magnified about 1000 times.  
(After Duggar)

portions of the trees every fall and winter. Cutting out blighted twigs immediately after blossoming is also helpful.

The black knot of plums and cherries and the black rot of apples are very common fungous diseases which, like the pear blight, may be controlled in part by careful pruning and burning of the affected branches, twigs, leaves, and fruit.



FIG. 138. Effects of cotton wilt

The plant is dying because its water-carrying tissues are clogged by the cotton-wilt fungus.  
(After Orton)

**379. Diseases controlled wholly or in part by crop rotation.** Cotton wilt is caused by a fungus which lives in the soil and enters the roots of the cotton plant when the plant is young (Fig. 138). The mycelium growing up into these parts soon plugs the water-carrying vessels of the root and stem, the water supply is thus cut off, and the plant wilts. One kind of spore is produced within the vessels of the cotton plant, and when the plant dies, another kind is formed on the outer bark of the stem. These spores are scattered by winds and insects, and help to spread the disease to other plants.

This parasite produces two other kinds of spores in the soil, and these help to spread the disease. This fungus may live in the soil from year to year, and cotton planted on such soil may become diseased. In addition to being spread by spores, the fungus is distributed by direct growth through the soil, by being carried from place to place by cultivators, plows, drainage water, the feet of horses and cattle, and in

other kinds of spores in the soil, and these help to spread the disease. This fungus may live in the soil from year to year, and cotton planted on such soil may become diseased. In addition to being spread by spores, the fungus is distributed by direct growth through the soil, by being carried from place to place by cultivators, plows, drainage water, the feet of horses and cattle, and in

stable manure. Other well-known diseases which, like cotton wilt, may live in the soil are flax wilt, the root rot of tobacco, and the dry rot of the Irish potato. The most practical method of control known for soil-infecting diseases is crop rotation. On badly infected soil, it is sometimes necessary to discontinue a certain crop for a long period, in some cases permanently.

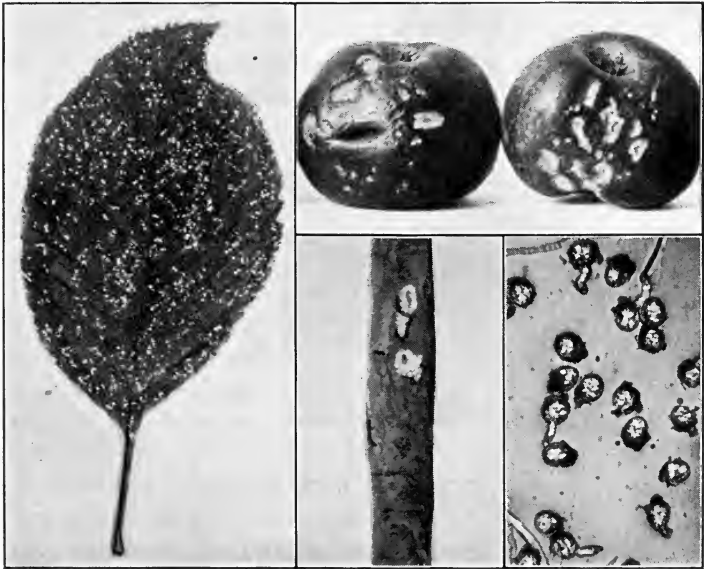

FIG. 139. Apple blotch

The leaf has many spore cups showing as reddish spots; two apples show the characteristic blotches; the twig shows two cankers due to this disease; the greatly magnified spores at the right show how the spores germinate. (Photographs by D. E. Lewis)

**380. Diseases wholly or in part controlled by spraying.** The late potato blight is caused by a fungus which attacks the leaves, usually after the blossoming period. This fungus first appears on the foliage and produces an abundance of spores. Some of these spores are scattered by the wind to other plants and some are washed by rain into the soil, where they infect the tubers and produce a dry rot. Some of the diseased tubers when planted the next season may produce diseased plants and an

abundance of spores, which again may cause widespread infection. Late blight can be controlled by spraying the potato plants with Bordeaux mixture two or three times during the season at intervals of from ten days to two weeks, beginning when the plants are about six inches high. Spores falling on sprayed plants are poisoned by the spray before they can grow sufficiently to infect the potato plants. Care should be taken not to plant potatoes infected with the disease.

**381. Apple blotch.** Apple blotch (Fig. 139) is another typical disease which can be controlled by spraying. It is caused by



FIG. 140. Brown rot of peaches

These peaches grew on unsprayed trees. (After Scott and Ayers)

a fungus which occurs on the fruit, twigs, and leaves of the apple, the principal damage being done to the fruit. The blotch appears as a hard brown spot on the fruit, as small cankers or slightly enlarged cracked areas on the twigs, and as light-brown or yellow spots on the leaves. The

disease-producing fungus lives through the winter in the cankers on the twigs and in the spring produces spores which ooze out in great numbers. These are distributed by wind and rain and probably by insects. When they fall on the fruit and germinate, a mycelium is produced which penetrates the skin, again causing blotch. The disease is common in the central Mississippi Valley region and the southern half of the apple belt. Spraying with Bordeaux mixture is an effective preventive.

Examples of other diseases distributed principally by spores and controlled by the application of sprays are the brown rot of peaches (Fig. 140) and plums, the early blight of potatoes, the scab and bitter rot of apples, and the leaf curl of peaches.

**382. Diseases controlled by seed disinfection.** The stinking smut of wheat, sometimes called *bunt*, is caused by a fungus which produces dark-colored kernels in the affected heads. These

dark-colored grains are filled with smut spores. When the grain from a smutted crop is threshed and handled in sacks, bins, and machinery, the smutted kernels or smut balls break and the spores are scattered over the other grains. When this infected seed is planted and germinates, the smut spores germinate also and produce smut plants. These are little tubes or filaments which attack the sprouting wheat plants, usually below the ground line, penetrate them, and live and grow inside until the grain is about to mature. The smut then develops its spore masses in place of seed. These spores mature when the grain is ripe and break in threshing and handling, scattering the spores over next year's seed.

The smut of oats (Fig. 141), covered smut of barley, kernel smuts of sorghums and broom corn, and a smut of millet have somewhat similar life histories. The loose smuts of wheat, as well as other smuts, have their own peculiar life histories and effects upon their hosts.



FIG. 141. Oat smut

The smut has occupied all the grains, thus completely destroying them and at the same time producing a large crop of spores to infect next year's crop. (Photograph by E. C. Johnson)



FIG. 142. Loose smut of wheat

At left, a healthy head; at right, two heads with grain completely destroyed by the smut. (Photograph by E. C. Johnson)

**383. Preventive treatment of smuts.** In the smuts which are carried from year to year by spores adhering to the seed, smut infection can be prevented by some disinfecting treatment which kills the spores and does not injure the grain for seed. Treatment of seed wheat in water at a temperature of 132 degrees F. to 133 degrees F. for from ten to fifteen minutes, or in a formalin solution composed of one pound of formalin to forty-five gallons of water until every kernel is thoroughly wet, destroys the spores. If the treatment is properly done, the seed is not injured and the disease is prevented. Treatment for oats,

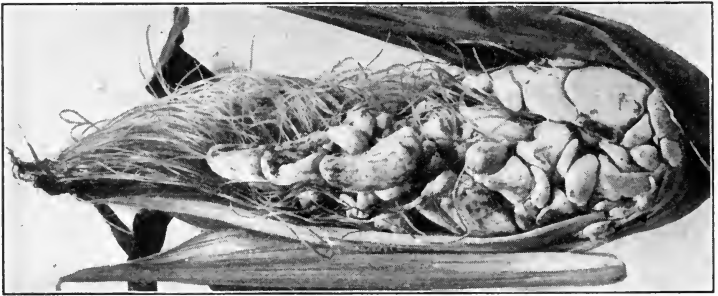

FIG. 143. Corn smut

The grains have become completely occupied and greatly distorted by smut.  
(Photograph by E. C. Johnson)

barley, and sorghum smuts are similar. The planting of seed from a clean field, which has not been contaminated in smutty sacks, bins, or machinery, will result in a clean crop.

The loose smuts of wheat (Fig. 142) and barley affect not only the kernels but the chaff, producing at heading time a sooty mass of spores which are scattered by the wind. When these spores lodge in the flowers of the wheat or barley, they germinate and grow inside the developing seed. The wheat smut infects only wheat; the barley smut only barley. The presence of smut in the seed cannot be detected, but when the seed is planted and germinates, the smut grows also inside of the plant until the head is ready to form, when in place of a sound head a smutted head occurs. As the smut plant is inclosed within the

seed and does not cling to the outside, it is very difficult to prevent loose smuts. It may be done, however, by soaking the seed

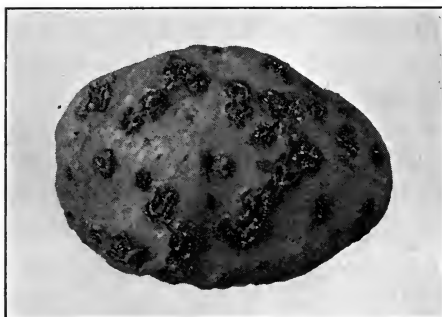

FIG. 144. Potato scab

The eruptions upon the surface of the potato are due to the disease. (After Corbett)

in cold water for five hours and then immersing it in hot water at a temperature of 129 degrees F. for wheat and 126 degrees F. for barley, for ten and thirteen minutes respectively. The smut germ is more delicate than the seed itself and is killed by the rise in temperature, while the seed remains practically uninjured.

For corn smut (Fig. 143) no effective prevention is known. Potato scab (Fig. 144), also caused by fungous growth, is common to potatoes all over the United States. This disease can be controlled by planting clean seed in clean soil or by treating the uncut seed tubers for two hours or more in a formalin solution composed of one pint of formalin to thirty gallons of water.

**384. Diseases controlled in part by growing resistant varieties.** Rusts in grains are common in almost all grain-producing regions, but they are most abundant in humid regions. They are caused by fungous growth and are indicated by the yellowish-brown,

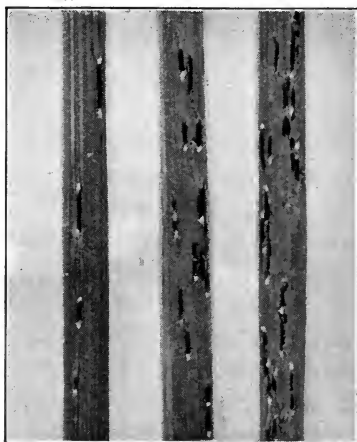

FIG. 145. Stems of wheat with rust  
The parasite lives within the stem, and when spores are formed, the surface is ruptured, producing the reddish or brownish patches. (After Freeman and Johnson)

reddish-brown, or black spots on stems (Fig. 145) and leaves of the affected plants. There are several species of rusts, each species being confined more or less closely to its own particular host plant. When the spores are scattered and fall on new wheat or oat plants and the weather conditions are favorable, the infection of new host plants takes place.

The prevention of rusts is very difficult. Individual treatment of plants cannot be undertaken. Since the grain fields are extremely extensive, spraying is out of the question. Since the rust is not transmitted through the seed, it cannot be controlled



FIG. 146. Cowpeas on wilt-infected soil

The variety known as "The Iron" at the left is resistant to the disease; that at the right is nonresistant. (After Orton)

by seed treatment, and crop rotation is of little help. The only method of controlling grain rusts is to grow varieties of grains which are resistant to the disease. Some are already known, such as the durum wheats, common on the great plains of the middle Northwest. Crossing with them is being carried on, and there is promise that valuable resistant varieties may be obtained. The use of varieties of plants resistant to disease is well illustrated by the growing of rust-resistant asparagus, recently developed by the United States Department of Agriculture, wilt-resistant cowpeas (Fig. 146), and wilt-resistant cotton. Even the chestnut-bark disease (Fig. 147), which has recently destroyed whole forests of chestnuts in the East, probably will not injure the Japanese chestnut or its hybrids.



**385. Sanitation and quarantine.** Other important means of control of plant diseases besides pruning, crop rotation, spraying, seed treatment, and growing of disease-resistant varieties are sanitation and quarantine. For example, if a district in which pear blight has been prevalent is inspected every year and kept clean by rigid pruning and burning all diseased fruit, leaves, twigs, and branches, the disease may be controlled more easily from year to year. Similarly, if wheat seed free from stinking smut is planted in a community and no smut is carried into that community by machinery, sacks, or implements which have been used in handling smutty wheat, such a community may remain free from stinking smut.

Diseases prevalent in one country or state and not in others may often be prevented from getting a foothold in disease-free regions by quarantine against the importation of diseased plants. Such quarantine can now be declared by the United States through the



FIG. 147. Chestnut almost killed by blight

The fungus-producing chestnut blight girdled this tree just above the first limb. All upper limbs have been killed. (After Metcalf)

Federal Horticultural Board and has already been employed against several diseases, among which the blister rust of the white pine, a very destructive disease in European nurseries, and the potato wart, a dangerous disease of potatoes which is prevalent in the British Isles and on the continent of Europe, are striking examples.

## QUESTIONS AND PROBLEMS

1. What are the most important plant diseases of your locality? of your state?
2. Secure from your county assessor a statement of last year's production of wheat, oats, or barley. Assuming that 5 per cent of the crop was destroyed by smuts and 5 per cent by rusts, estimate what these diseases cost your county last year?
3. How do plant parasites and plant saprophytes differ?
4. Describe the parasitic flowering plant known as dodder.
5. What are bacteria and fungi? Are all bacteria and fungi parasitic?
6. What are the more important methods of distribution of bacteria and fungi?
7. What are the principal methods of control of plant diseases?
8. What methods of controlling or preventing plant diseases are used in your locality?
9. Secure an agricultural experiment station bulletin giving directions for treating wheat and oat seed for smut, and prepare a brief specific outline of the things that should be done.
10. Describe some methods of sanitation to prevent plant diseases.
11. What is meant by quarantine against plant diseases? Does your state enforce such quarantine?

## EXERCISES

**1. A study of bacteria.**

**MATERIAL:** A compound microscope with equipment; a piece of stale bread; and a tumbler of water.

Place a small piece of bread in a tumbler of water and let it stand twenty-four to forty-eight hours. Examine a drop of the liquid under the microscope. A large number of forms of bacteria will be noticed; also small animals are likely to be present. Some of the bacteria will appear to be spherical, others rodlike, often forming long chains. Many swim rapidly across the field.

**2. Bacteria from soil and air.** Boil some sweetened water in three glass flasks until all life in the water is destroyed (ten minutes). After the water has cooled, drop a piece of field soil into one flask. Allow another flask to stand exposed to room atmosphere for twenty-four hours. Keep the other flask constantly closed. After three days make a microscopic study of some of the water from each flask.

### 3. Bread mold.

**MATERIAL:** Tumblers; stale bread; small pieces of cardboard; hand lenses; compound microscope.

Dip some stale bread in water, place it in a tumbler, and cover with a piece of cardboard. Let it stand in a warm place for from three days to a week. Remove the bread and notice the grayish white mass of mold which covers it. Examine this under a hand lens, noticing the mycelium. The dark color is due to the formation of sporangia. Mount some of the fungus in a drop of water under the microscope, and notice the mycelium, sporangia, and spores.

### REFERENCES

- DUGGAR, B. M. Fungous Diseases of Plants. Ginn and Company.
- FREEMAN, E. M. Minnesota Plant Diseases. Webb Publishing Company.
- STEVENS, F. L., and HALL, J. G. Diseases of Economic Plants. The Macmillan Company.
- The Development of Farm Crops Resistant to Disease, Year Book of the United States Department of Agriculture, 1908.
- Wilt Disease of Cotton, Watermelon, and Cowpea, *Bulletin 17*, Division of Vegetable Pathology, United States Department of Agriculture.
- The Rusts of Grain in the United States, *Bulletin 216*, Bureau of Plant Industry, United States Department of Agriculture.
- Cotton Wilt, *Farmers' Bulletin 133*, United States Department of Agriculture.
- The More Important Insect and Fungous Enemies of the Fruit and Foliage of the Apple, *Farmers' Bulletin 392*, United States Department of Agriculture.
- Potato Tuber Diseases, *Farmers' Bulletin 544*, United States Department of Agriculture.
- The Smuts of Wheat, Oats, Barley, and Corn, *Farmers' Bulletin 507*, United States Department of Agriculture.
- Spraying Peaches for the Control of Brown Rot, Scab, and Curculio, *Farmers' Bulletin 440*, United States Department of Agriculture.



## CHAPTER XXVI

### INSECTS ON THE FARM

And the locusts went up all over the land of Egypt, and rested in all the borders of Egypt; very grievous were they; . . . For they covered the face of the whole earth, so that the land was darkened; and they did eat every herb of the land, and all the fruit of the trees which the hail had left; and there remained not any green thing, either tree or herb of the field, through all the land of Egypt. — THE BIBLE

**386. The importance of insects.** The best authorities agree that the injuries caused by insects equal at least 10 per cent of the value of farm crops. This enormous loss is so constant that few realize the total damage, which has now reached a billion dollars annually. This is equal to the entire expenditures of the national government, or it is more than four times the annual national property loss by fire.

Four fifths of all known species of animals are insects. About 350,000 different species have already been described, but it is estimated that over 1,000,000 species exist.

There are many insects, however, which contribute directly to the wealth of the world. The silkworm produces over \$200,000,000 worth of silk annually, and the honeybee produces in the United States alone over \$20,000,000 worth of honey a year. Others contribute to the interests of man, as in the case of those which pollinate the economic plants or those which prey upon or live within the bodies of destructive insects, thus preventing their depredations.

**387. Structure and feeding of insects.** An insect has three distinct regions of the body—head, thorax, abdomen; three pairs of legs, one pair of antennæ, and usually one or two pairs of wings. All insects may be divided into two great classes, according to whether their mouth parts are formed for biting or for sucking. If the mouth parts of a grasshopper or cockroach

(Fig. 148) are examined, it will be found that there is a distinct pair of jaws adapted for biting and chewing. Insects of this class, in feeding, bite off a portion of the solid substance of the leaf or plant and swallow it. On the other hand, if the head of a squash bug is examined, no jaws will be found (Fig. 149), but instead there is a stout beak fitted for piercing and sucking. As the insect feeds, the beak is thrust down through the outer layer of the

bark or leaf into the soft, succulent tissue beneath, in order to extract the plant juices which nourish the insect.

Insects with biting mouth parts may be killed by covering the plant on which they are feeding with a stomach poison, such as lead arsenate. Inasmuch as insects with sucking mouth parts do not bite off any of the surface of the plant, they cannot be killed by applying stomach poisons. For these insects, sprays must be used that will kill by their caustic, or corrosive, action on the body of the insect.

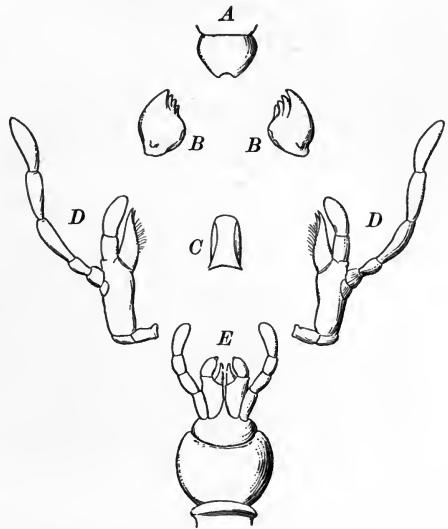

FIG. 148. Parts of an insect's mouth

The parts shown are from the mouth of a cockroach  
*A*, upper lip; *B*, mandibles; *C*, tongue; *D*, maxillæ; *E*, lower lip

**388. Insects undergo changes in form.** Nearly all insects in their development undergo very remarkable changes of form expressed by the term *metamorphosis*. The egg of a grasshopper produces a creature which, except for the absence of wings, resembles the adult. This form, known as the *nymph*, feeds and grows, molts several times, and develops into the adult. Grasshoppers, chinch bugs, and dragon flies have this type of life history.

On the other hand, the egg of a moth produces a caterpillar, which is the active feeding stage, or the stage in which the insect

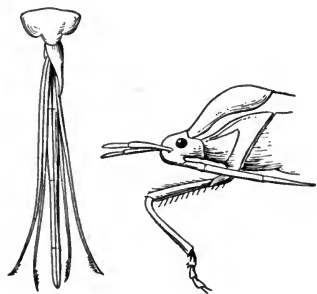

FIG. 149. Mouth parts of a squash bug—adapted for piercing and sucking. (Enlarged.) (Redrawn from Comstock)

does its serious injury. The caterpillar feeds, molts, and grows, and when fully grown, it spins, in many cases, a firm casing of silk known as a cocoon. In this protective case it is transformed into a *pupa*, which is the inactive, or dormant, stage of development. The pupa takes no food. It resembles neither the caterpillar nor the moth. In many cases it passes the winter in this stage, so that the pupal stage varies from a few days in summer to several months

in winter. Finally, the pupal shell splits open and the adult moth (Fig. 150) emerges with wings soft and limp but expanding and hardening in a few hours. Butterflies, beetles, flies, bees, and ants have this type of life history.

Insects of the latter type are said to have a complete metamorphosis, while those of the former have an incomplete metamorphosis. The growing stage for all insects having complete metamorphosis is the *larva*, known as the caterpillar of the moth or butterfly and the maggot of the house fly.

Three distinct types of injurious insects will be discussed here—one a pest on staple crops, another a pest on fruit, and another a pest on the leading fiber plant.

**389. The chinch bug—distribution.** The chinch bug, one of the greatest pests to grain and grass crops, is found generally distributed over the United States east of the 105th meridian. The worst injury, however, occurs to the small grains and to corn in the Central States, and it has been estimated that the average annual loss to crops amounts to \$40,000,000.

**390. Life history and habits of the chinch bug.** This insect passes the winter as an adult in clumps of grass, in corn shocks, and under rubbish. The adults emerge from hibernation from

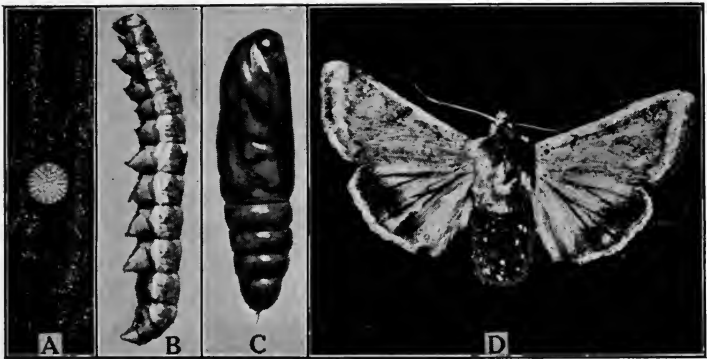

FIG. 150. Stages in the development of the corn-ear worm

*A*, egg; *B*, caterpillar; *C*, pupa; *D*, adult. (All enlarged.) (After Headlee and McColloch)

March to May and move to the small grainfields. After feeding for some time the females begin depositing eggs on the roots or in the leaf sheaths of the plants (Fig. 151).

These eggs hatch in from two to three weeks and the young bugs feed in the small-grain fields until harvest, when they migrate to the cornfields. Here they reach maturity and eggs are laid on the corn plants or on the grasses in the cornfield. These eggs hatch in about two weeks and the second brood feeds and matures in the cornfields. Generally all the bugs have reached maturity from the middle to the last of September. When the food is gone or cold weather comes, the adults migrate to their winter quarters.

**391. Methods of controlling the chinch bug.** There are two times in the year when the chinch bugs can be successfully combated. The first occurs during the summer when the bugs migrate from the small grain to corn, and the other occurs in the fall after the bugs are firmly established in winter quarters. The problem of summer destruction involves the necessity of constructing dry-weather

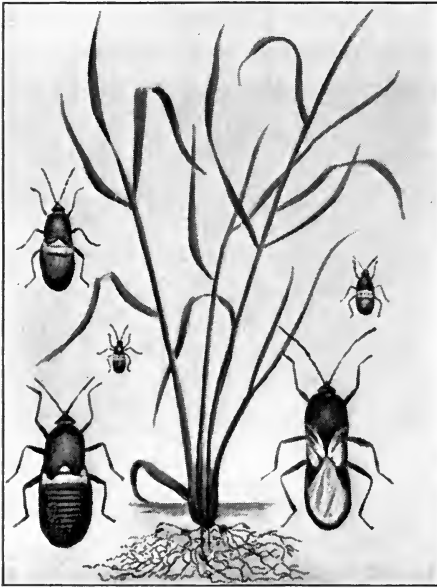

FIG. 151. Stages in the development of the chinch bug

and wet-weather barriers. During dry weather a deep furrow should be plowed around the infested field just before harvest. The sides and bottom of this furrow should be reduced to a fine dust by dragging a heavy log back and forth in the furrow. This furrow should be dragged every day during the migration and the bugs destroyed in it by burning them with a gasoline torch. In wet weather, it is necessary to run a barrier of coal tar or crude oil around the

infested field. Post holes are dug at intervals of twenty feet along the inside of this barrier, and the bugs on being trapped in these holes are destroyed by kerosene.

Winter destruction involves thorough fall burning of clump-forming grasses where these grasses are the principal cover. When bugs are found hibernating in corn shocks and under leaves and rubbish, these places should be renovated during the fall so as to prevent the next spring's crop of insects.



**392. Codling-moth distribution.** The codling moth has been known for hundreds of years. It was described and given its scientific name in 1758 by Linnæus, the man who devised our present system of naming plants and animals. It is present in the United States wherever apples are grown. In 1907 Professor Quaintance estimated the annual loss due to this insect in the United States at about \$12,000,000.

**393. Life history and habits of the codling moth.** The moths appear in early spring, and about two weeks after the apples are in blossom the females lay their eggs on the leaves, usually on the upper side, and more rarely on the young fruit. When the eggs hatch, the young larvæ feed for a short time on the foliage and then make their way to the nearest apple and bore into it, usually through the blossom end (Fig. 152). They feed about the core of the apple until they are full grown, which is about the first

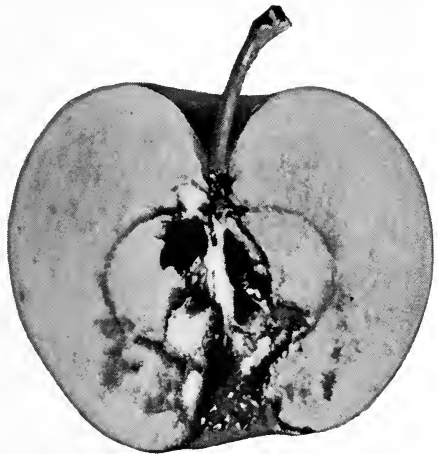

FIG. 152. Work of the codling-moth larva in an apple. (After Lamson)

of June. During June and July the larvæ emerge from the fruit and pupate. Pupation generally occurs under loose scales of the bark or in loose trash on the ground. In a short time moths again appear and begin laying eggs for the second brood. This time the greater number of the eggs are deposited on the fruit, and the larvæ, as soon as they are hatched, bore into the fruit through the side or at either end. Unless the season be exceptionally long, these larvæ make cocoons in which they usually remain through the winter as larvæ, pupating the next spring. In exceptional seasons a third brood may be formed.

**394. Methods of controlling the codling moth.** The codling moth is now controlled almost universally by spraying the trees with an arsenical poison in the form of a liquid. Of late the arsenate of lead, applied at the rate of from two to three pounds to fifty gallons of water, has been used almost entirely. Several treatments a year are necessary for the best results. The first should be given just as the petals are falling. This should be followed in three weeks by a second spray. For the second brood of codling moths a treatment should be applied about ten weeks after the first spraying.

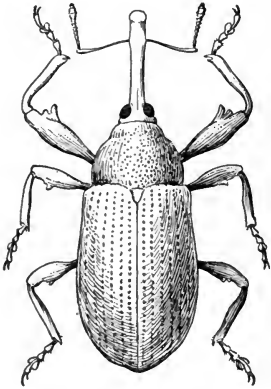

FIG. 153. Cotton-boll weevil. (Enlarged six times.) (After Hunter and Pierce)

**395. The cotton-boll weevil — distribution.** This insect, a native of Central America, gradually worked its way up through Mexico and was first noticed in Texas about 1890. It is now distributed throughout the greater part of most of the cotton-growing states, and a conservative estimate shows that since the weevil has invaded this country it has caused a loss of \$20,000,000 annually.

**396. Life history and habits of the cotton-boll weevil.** The adult is a small, brownish, stout beetle about one fourth of an inch long (Fig. 153). The larva is a footless white grub with a brown head, and is found only within the square or the boll (Fig. 154). The injury is done both by the adults in their feeding and egg laying, and by the grubs which hatch from eggs laid within the bolls or the squares. Both the squares and the bolls are attacked and their contents so damaged that they die or fail to produce fiber. The adult weevils feed entirely during the day.

The adult beetles begin to emerge from their hibernation soon after the cotton is up, and continue to emerge until about the time when the cotton squares begin to form. The

beetles feed on the foliage, and as soon as the squares are formed the females lay their eggs within them; as the grubs develop, the squares usually fall to the ground. The grubs pupate within the squares, and soon a second generation of adults is out. The time from egg to adult, with favorable climatic conditions, is from two to three weeks. Four or five generations of these insects are produced in one season. The

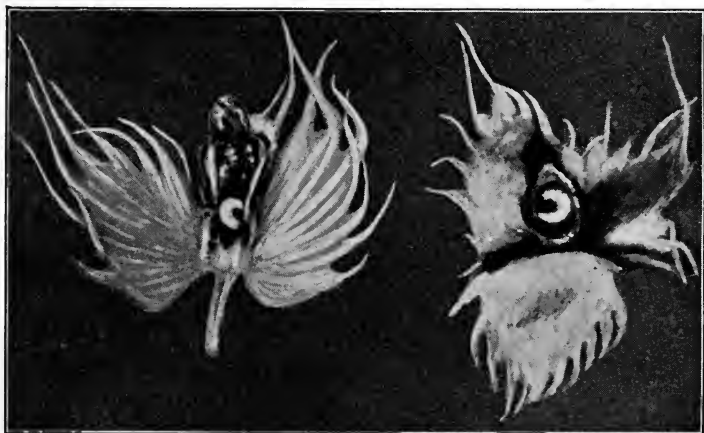

FIG. 154. Effects of the cotton-boll weevil

The larva of the boll weevil is shown in the center of a bud or square, and of a boll; it destroys the central part of both

female beetles prefer the square, but when squares are no longer available, eggs are laid in the bolls.

In some localities the migration of the adult boll weevils begins by the middle of August. However, it is the great dispersion of the early fall which carries the insect far into the new territory. It is gradually spreading over all the cotton-producing states. With the advent of cool weather in the fall the adult weevils in the cotton fields seek protection against the winter and thus fly from the fields in every direction. They may hibernate in hedges, woods, cornfields, haystacks, farm buildings, and in trash and weeds in the cotton fields.

**397. Methods of controlling the cotton-boll weevil.** The most important means of control is a thorough cleaning of the cotton fields as soon as the cotton is picked. This should include the destruction of all stalks, dead bolls, and crop remnants. In this way the great bulk of the adult beetles and the immature stages in the squares and bolls are destroyed. This method, when supplemented by a thorough cleaning of the hedges, fence rows, and other waste places, results in the death of a large proportion of the weevils.

Another means of control, especially in localities where cheap labor may be had, is by gathering the fallen squares. However, since many of the larvæ in these squares are parasitized, these gathered squares should not be burned but be placed in wire cages so that the parasites may escape. The wire on the cages should be tight enough to retain the weevils but not tight enough to prevent the escape of the parasites. If the squares are burned the enemies of the weevil are destroyed.

Any practice that will help to get the cotton planted and matured early will help to avoid serious injury, because the cotton will be well along before the weevils have become abundant. Winter plowing, early spring planting, providing for plenty of space between the rows, the use of early-maturing varieties, and frequent cultivation in the growing season are advisable.

**398. Helpful insects.** A study of insects, such as can be made with simple apparatus (Fig. 155), will show that many are useful and many harmful. The honeybees are useful because they supply food. Others, as the silkworm, supply materials for clothing. The predacious insects are those which attack other insects, devouring them bodily, tearing them to pieces, or sucking their life blood. Good examples of these are ladybirds, dragon flies, ground beetles, robber flies, lacewings, and tiger beetles.

The parasitic insects differ from predacious ones in that they spend all or a large part of their life cycle within the bodies of their victims, and thus destroy them. These are the ichneumon

flies, braconids, chalcis flies, tachina flies, and bee flies. Predacious and parasitic insects are very numerous, both in individuals and in species. They are the most destructive foes of insect life. Were it not for these insects feeding upon injurious ones the loss to crops would be much greater than it is, and in many cases it would be almost futile to attempt to check injurious insects.

### 399. Preventing and controlling insect injuries: clean farming.

Clean culture means the destruction of weeds, the removal of all crop remnants as soon as the crop is gathered, and the burning of rubbish.

Such insects as the cabbage worm, harlequin cabbage bug, and squash bug pass the winter in the old cabbage stumps left in the field, or in weeds

and grass growing near by. The farmer should destroy all hiding places that may be of service to the insects for winter quarters. Clean farming helps greatly in controlling insects.

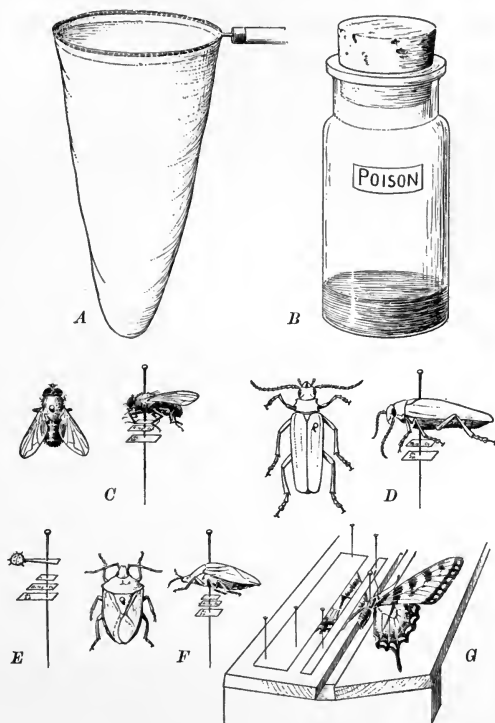

FIG. 155. Materials and methods for mounting insects

*A*, a collecting net made of broom handle, wire, and cheesecloth or mosquito netting; *B*, a cyanide bottle for killing insects; *C*, *D*, *F*, method of pinning flies, beetles, and bugs, respectively; *E*, small insects mounted on cardboard points; *G*, method of spreading butterflies. (After Dean)

**400. Fall plowing and disking.** Many injurious insects, such as cutworms, corn-ear worms, wireworms, and white grubs, pass the winter as larvæ and pupæ in the soil, or hibernate about the roots of weeds and grasses. Breaking up the soil in the late fall and exposing these wintering forms to their natural enemies and to unfavorable weather will greatly reduce their number. Disking alfalfa is an effective method of destroying grasshoppers, army worms, and cutworms.

**401. Place and time of planting.** Too frequently corn and other cereals are planted in places where they will be subjected to the attack of insects that are already present. Corn following grass or clover sod is likely to be attacked by cutworms and white grubs, and if planted in marshy tracts, is in danger from wireworms and billbugs. Planting at the proper time is a protection to many crops; for example, wheat sown after the first week in October is usually free from the attack of the Hessian fly.

**402. Crop rotation.** By a thorough system of crop rotation the increase of many insect pests may be checked or prevented. This will starve out such an insect as the Western corn-root worm, which is never injurious to the corn after the land has been in small grain. White grubs, cutworms, wireworms, plant lice, and the Hessian fly may be controlled in this manner.

**403. Good soil, clean seed, and thrifty plants.** Thorough preparation of the soil induces rapid growth and thrifty, vigorous plants. It also disturbs and exposes the insects that are in the ground. Plants which are in good, thrifty condition are better able to resist the attack of insects. Plants in a weak condition, or with no vitality, soon succumb to the attack of an insect enemy. A good stand lessens the danger from injurious insects. The field partly grown up with foreign weeds and grasses will encourage pests, hence the importance of weed-free seed.

**404. Barnyard fowls and native birds.** Chickens, guineas, ducks, turkeys, and geese are continually in search of those insects that may be found upon low plants and in grasses and weeds, and under rubbish and fallen leaves. Grasshoppers have often been controlled by these fowls.

Wild birds depend very largely on insects for food, and constitute one of the most valuable means of insect control. Were it not for our birds the depredations of insects would be much greater. America is fortunate in having a large number of birds, and of these very few indeed are destructive to farm and orchard crops.

### QUESTIONS AND PROBLEMS

1. What are the stages in the development of insects?
2. How are the mouth parts of insects related to their food habits?
3. Name at least a dozen insects which are injurious in your locality and describe where and how each kind lives.
4. In what ways are insects beneficial?
5. How much injury is estimated to be done by insects in the United States?
6. Why is it important to know the life history and habits of an insect?
7. Tell briefly the life history of the chinch bug, of the codling moth, and of the cotton-boll weevil, and the best methods of prevention of each.
8. How will clean farming, rotation of crops, and good farming control many of the serious insect pests?
9. In what ways are birds important in the growing of crops? What local native birds are of most importance to your crops?
10. What are your state laws relating to the protection of birds which have agricultural importance?

### EXERCISES

1. **Insect study.** A school collection showing the life history of injurious and of beneficial insects should consist not only of specimens showing the different stages of development of the insects but of samples of their work.

2. **Collecting.** Select bright, still, warm days and with the net sweep the plants along the roadsides and in meadows. Collect insects in wheat, corn, and in orchards, woods, and fields; look under stones, in woodpiles, and in rubbish; skim the surface and scrape the bottom of ponds and streams; visit electric lights at night.

3. **Preserving insects.** Preserve eggs, larvæ, and soft-bodied insects in a 3-per-cent solution of formalin or in a 70-per-cent solution

of alcohol. Adult insects should be pinned and kept in a small box such as an empty cigar box.

**4. A study of the life history of the cabbage butterfly.** This work may begin either in the fall or in the spring. The cabbage butterflies should be collected and one pair placed in each of a number of screened breeding cages. Each cage should contain a small potted cabbage plant or fresh cabbage leaves standing in water.

By close observation the full life cycle may be seen, including egg, larva, pupa, and adult; the habits and structures may be determined; and a collection illustrating the life cycle may be prepared.

Other insects may be studied in similar ways.

#### REFERENCES

- CHITTENDEN, F. H. *Insects Injurious to Vegetables*. Orange Judd Company.
- COMSTOCK, J. H. *Manual for the Study of Insects*. Comstock Publishing Company.
- KELLOGG, V. L. *American Insects*. Henry Holt and Company.
- SANDERSON, E. D. *Insect Pests of Farm, Garden, and Orchard*. John Wiley & Sons.
- SANDERSON, E. D., and JACKSON, C. F. *Elementary Entomology*. Ginn and Company.
- SLINGERLAND, M. V., and CROSBY, C. R. *Fruit Insects*. The Macmillan Company.





## CHAPTER XXVII

### SPRAYING

**405. Significance of spraying.** The surfaces of plants may be treated with substances which prevent injury by insects or fungi. A substance that destroys insects is called an *insecticide*, one that destroys a fungus, a *fungicide*. The terms *sprays*, *sprayer*, and *spraying* have come to have specific meanings in connection with the control of insects and disease. A spray is a material, a sprayer a machine, spraying the operation ; and the terms cover the use of both liquid and powdered materials.

Sprays have been used by gardeners and florists for a long time. Formerly the liquids were applied with a syringe and the dust with a bellows. For very many years grape growers have dusted sulphur upon their vines to prevent mildew, and florists have killed plant lice with soapsuds and decoctions of tobacco.

About 1870 the Colorado potato beetle became abundant and caused heavy losses to potato growers. A cheap poison was needed, and Paris green was found to be very effective in killing the insect. It was mixed with flour or lime and dusted upon the plants, or mixed with water and sprinkled from a watering pot, or spattered upon the plants with a whisk broom. Too much of this poison injured the tissue of the leaves, and the problem became one of distributing the material evenly over the surface in sufficient quantity to kill the insect without injuring the plant. The success in controlling the potato beetle

suggested the use of sprays for other insects. The cankerworm and the codling moth often caused serious loss, and orchard growers were greatly in need of means of control.

As early as 1878 results were published which indicated such a degree of success that numerous other experiments were undertaken, and since that time many bulletins and several books have been published on the subject. Many men have



FIG. 156. A gasoline power-spraying machine

spent years in experimenting with chemicals and appliances, and the manufacture of spraying materials and spraying machinery is now an important industry.

**406. Insecticides.** The potato beetle and the codling moth are common insects which consume the tissue and are killed by sprays containing poison (Fig. 156). In such cases compounds of arsenic are most effective. Arsenate of lead and Paris green, which is a combination of copper and arsenic, are cheap and are generally used. Paris green acts rather more quickly, is

more likely to injure plant tissue, and is less adhesive than arsenate of lead.

When quick results are desired Paris green and arsenate of lead are sometimes used in combination. The usual proportions for this combination are two pounds of arsenate of lead and one-half pound of Paris green to fifty gallons of water. This has been effective in cases where cankerworms were so numerous as to threaten entire defoliation of apple trees.



FIG. 157. Boiling lime-sulphur spray

A class of Georgia high-school pupils getting some first-hand usable information about the preparation of spraying solutions

The insects which have sucking mouth parts are killed by applying materials which destroy the body tissue, or smother the insect by closing its spiracles, or breathing tubes. Of this group the San José scale is one of the most destructive pests, and the most effective control of it is secured by coating the plants with a combination of lime and sulphur, known as lime-sulphur wash (Fig. 157).

There are many species of aphids, or plant lice, which sometimes cause serious loss. The green melon louse and the brown plum louse are common, and occasionally the apple aphid is so

numerous in early spring as seriously to injure the young fruit buds. In greenhouses the insects which attack chrysanthemums, lettuce, and many other plants are usually controlled by heavy fumes of tobacco smoke, but for outdoor crops tobacco decoctions, soapsuds, and an emulsion of kerosene and soapsuds are most used.

**407. Spraying for fungous diseases.** In the multiplication of fungi large numbers of spores are formed. These spores are scattered and germinate upon the surfaces of plants. The spores and the young fungous plants are so much more delicate than the tissue of the host plant that it is possible to use chemical solutions sufficiently strong to destroy them without injuring the host plant.

Weather conditions must be observed carefully before applying these mixtures, as in moist weather copper solutions cause "spray burn," and in very hot, dry weather lime-

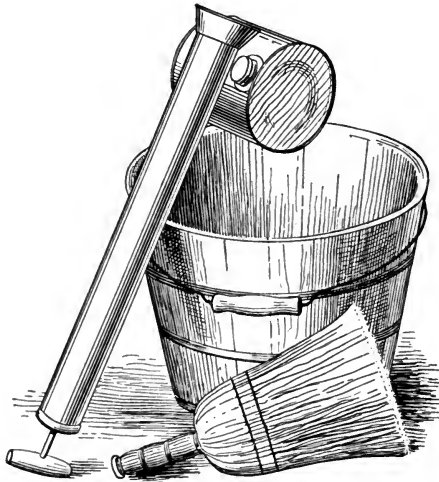

FIG. 158. Simple spraying outfit

For small bushes, or for situations where but a small amount of spraying is to be done, the hand pump and the spattering brush are adequate

sulphur wash has also been injurious in the same way.

**408. The copper sprays.** A number of copper compounds are used as sprays. The most common of these is copper sulphate, which is used alone in solution, or in combination with lime. A combination of copper sulphate and lime is called Bordeaux mixture, named from Bordeaux, France, where it was first used in the protection of vineyards against thieves. It was thus discovered that it protected also against disease.

Bordeaux mixture leaves a light blue deposit upon the plant tissue, and when this deposit is undesirable, or would injure the sale of the products, as with flowers or ripening fruits, a colorless compound known as the ammoniacal solution of copper carbonate is used. This solution is prepared by dissolving three ounces of copper carbonate in one quart of strong ammonia and diluting this with twenty-five gallons of water.

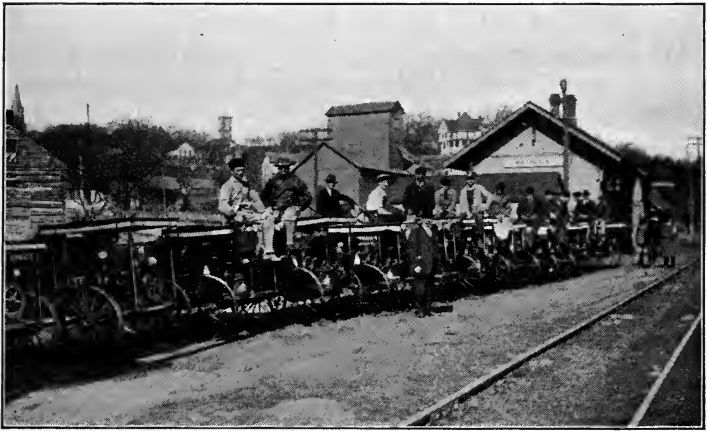

FIG. 159. Gasoline power sprayers and the owners who will use them

An orchard demonstration of spraying by the state agricultural college in this locality through three years has taught the farmers that "a little science is a dangerous thing" to insects and fungi

**409. Apparatus for spraying.** Outdoor work requires a good pump, with sufficient power to reduce the mixture to very fine particles through a nozzle that distributes it evenly. The amount of power required varies with the operation and the mixture to be applied. In applying washes for the control of scale or for aphids—mixtures that are not likely to injure the tissues of the plant—a nozzle with a larger aperture and a lower power may be used. In applying fungicides and insecticides that are likely to injure the plant tissues, it is essential that the surface be covered with a very thin coating.

**410. Hand sprayers.** For small orchards and garden work a hand pump is recommended (Fig. 158). The knapsack sprayer is useful for gardens and vineyards. For gardens of considerable area a hand pump mounted upon a barrel which can be transported by means of a cart should be used. The pump should be a force pump of considerable power, the working parts of which are of such material as will not corrode from contact with the chemicals. Brass alloy or porcelain linings are cheaper than solid brass parts, but are less durable.

**411. Power sprayers.** For larger plantations the size and capacity of the pumps should be increased (Fig. 159). Probably most orchard owners find that for an area of ten acres or more, a pump driven by a gasoline engine is economical and efficient.

A convenient-sized tank for spray mixtures is one containing two hundred or two hundred and fifty gallons, the size depending somewhat upon the topography, as it is readily seen that in an orchard or field with an uneven surface the draft will be much heavier than upon level ground.

The water supply is a very important consideration, and sufficient reservoir capacity should be arranged to allow the convenient mixing of the materials and filling the tanks with the least possible expenditure of time. In many cases, particularly the first sprays for the cankerworm and codling moth, the most efficient work is done within a comparatively few days, and if any considerable area is to be covered, all possible haste must be used.

#### QUESTIONS AND PROBLEMS

1. What experience suggested the use of sprays for the general prevention of injury by insects?
2. How are the feeding habits of insects related to control by spraying?
3. What common insecticides are used to protect plants against insects that consume the tissue?
4. How may the San José scale be controlled?
5. What methods are used for destroying aphids, or plant lice, in greenhouses? on outdoor crops?

6. What determines the kind of spray to be used and its means of application?
7. Describe the different kinds of apparatus used in spraying.
8. What is one of the most destructive insect pests of your locality? one of the worst fungus pests?

### EXERCISES

Select for experiment a fungous disease or insect pest which is injurious to some of the crops of the community. Write to your state agricultural college for directions in controlling these diseases and pests. Under these directions demonstrations of great importance may be made in the use of such sprays as the Bordeaux mixture, kerosene emulsion, and lime-sulphur. In Appendix I directions are given regarding the kind of spray to use and the time to apply it for various insect and fungus pests.

### REFERENCES

- BAILEY, L. H. *The Principles of Fruit Growing*. The Macmillan Company.
- DUGGAR, B. M. *Fungous Diseases of Plants*. Ginn and Company.
- LODEMAN, E. G. *The Spraying of Plants*. The Macmillan Company.
- SEARS, F. C. *Productive Orcharding*. J. B. Lippincott Company.
- STEVENS, F. L., and HALL, G. L. *Diseases of Economic Plants*. The Macmillan Company.
- Fungicides and Their Use in Preventing Diseases of Fruits. *Farmers' Bulletin 243*, United States Department of Agriculture.
- Some Factors Influencing the Efficiency of the Bordeaux Mixture. *Bulletin 265*, Bureau of Plant Industry, United States Department of Agriculture.
- Self-Boiled Lime-Sulphur Mixture as a Promising Fungicide. *Farmers' Bulletin 440*, United States Department of Agriculture.

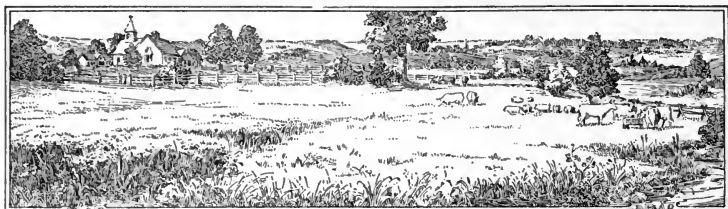

## CHAPTER XXVIII

### FEEDING ANIMALS

He causeth the grass to grow for the cattle, and herb for the service of man: that he may bring forth food out of the earth. — THE BIBLE

**412. Animal products are costly.** Farm animals digest less than three fourths of the feed that is given them. About half of the digested portion is required for maintenance, or for running the machinery of the body. Only one fourth to one third of the total nutrients that are fed are therefore available for the production of meat, milk, eggs, wool, or of energy for work. The processes of mastication, digestion, and production use energy also, and there is recovered in the animal product not more than 20 per cent, or one fifth, of the total nutrients fed. An animal is a more efficient machine, however, than any yet devised by man. Man's best machine is the steam engine, which returns at the drive wheel about 10 per cent of the energy contained in the coal which is burned.

**413. The uses of feed.** Food for maintenance includes that which is necessary to keep the body temperature uniform. Therefore a part of the food eaten by every animal is used as heating fuel. The animal body is a very complex machine, and, like any other machine, its parts are constantly wearing out. If these parts are not repaired from day to day, the machine gets out of order and fails to work. Some of the feed eaten goes to replace the tissue worn out, or to keep the body in repair. Energy is also constantly required to secure, chew,



and digest feed. The animal expends energy in standing, walking, or running, and in pumping the blood to all parts of the body. There is but one source of energy for the animal — the food it eats.

**414. Regulation of maintenance feed.** The above are examples of the use of food for maintenance. The consumption of food for maintenance on the average American farm is larger than it should be. The maintenance cost is less when the animal is comfortable and quiet than when it is exposed to the storms of winter or is harassed. The experienced cattle feeder knows that his steers will "run off" more weight in a half hour when excited by dogs or ill-tempered attendants than they will "lay on" in days. The dairyman has learned that kindness to his cows pays. It is also true that the more the animal is induced to eat, the larger is the proportion of its food which is productive and the smaller the proportion required for maintenance.

**415. What the animal produces.** Farm animals produce muscle, fat, bone, skin, hair, wool, feathers, horn, hoof, milk, eggs, and energy for work.

The mare with a young colt produces milk, and if required to pull the plow, produces energy for work also. It is readily seen, therefore, why the mare that produces both milk and energy must be liberally fed, compared with a horse that is only plowing. The young growing colt needs the food supplied by its mother's milk, and hay, oats, and perhaps pasturage for growth. The bone, muscle, hair, hide, and hoof which are produced must come from the feed eaten. When the colt matures it will no longer need feed for new growth, but when put to work it will need feed to supply the energy to draw the load. Mature cattle when fattened for the market produce only fat, while young cattle need feed not only for the production of fat but for growth also. The milk cow uses her feed for the production of milk and must be fed well, because milk is a fairly rich product and is produced by some cows in great quantities. Sheep need feed for all of the purposes named excepting work, and, in

addition, for the production of wool. Swine grow and fatten rapidly, hence their greediness. Therefore, it would be absurd to feed all kinds of animals in the same way and without regard to the kind of product they manufacture.

**416. Digestion of feed.** The feed must first be digested in the animal body. Most digestive changes are due to the action of the ferments, or enzymes, present in the digestive juices. Each ferment produces its own peculiar results; for example, diastase converts starch into a form of sugar, pepsin renders a part of the proteins of the food soluble, and lipase acts upon

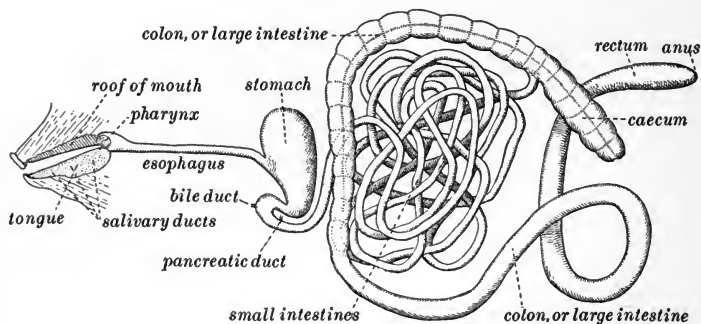

FIG. 160. The digestive tract of a hog. (Diagram from Iowa State College)

the fats of the food. Bacteria also play an important part in digestion of food, attacking the food chiefly in the large intestine. It is from the small intestine that most of the digested material passes into the blood to be carried to the different parts of the body.

**417. Organs of digestion.** Digestion begins with mastication and continues up to the time the undigested part of the food leaves the body (Fig. 160). Most animals masticate or chew their food as they eat it, and at the same time saturate the food with saliva. Cattle and sheep chew their food only sufficiently to allow it to be swallowed and remasticate it later. Fowls swallow their food whole and grind it in their crops and gizzards (Fig. 161). The horse and the hog have comparatively

simple digestive tracts. The cow, the sheep, and the deer, known as ruminants, have a complicated set of four stomachs, by means of which they are able to digest large quantities of coarse and comparatively unnutritious feed. The animals, such as the ruminants, which have subsisted for centuries upon coarse foods have a longer digestive tract than do those which have lived upon a more concentrated diet (Fig. 162). The digestive tract of cattle is about twenty times as long as the body; of sheep and goats it is about twenty-seven times; of the hog about fourteen times; and of the horse only about eleven times. The ruminants, with their large stomachs, can utilize much coarse material which would otherwise be wasted.

The digestive tract of the chicken is very different from that of the other animals described. The chicken has no means of chewing its food, therefore the food is swallowed whole and goes directly into the crop, where it is moistened and softened; thence it goes through the true stomach into the gizzard, where it is ground by the gritty material present. The craving of chickens for gritty materials is therefore easily understood.

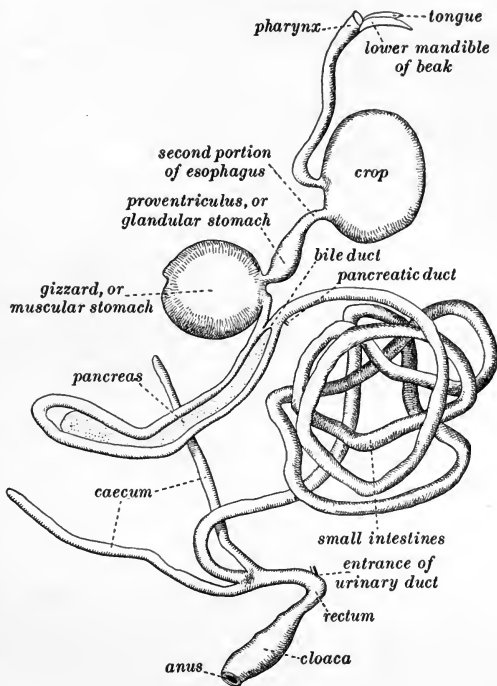

FIG. 161. The digestive tract of a chicken. (Diagram from Iowa State College)

**418. Improved and poor animals compared.** Different breeds of the same species and different individuals of the same breed appear to have approximately equal digestive power. It is a common notion that the improved breeds of farm animals digest their food more completely than do the unimproved kinds. It is true that the improved strains are capable of digesting larger quantities of food within a given time, but there is no reason to

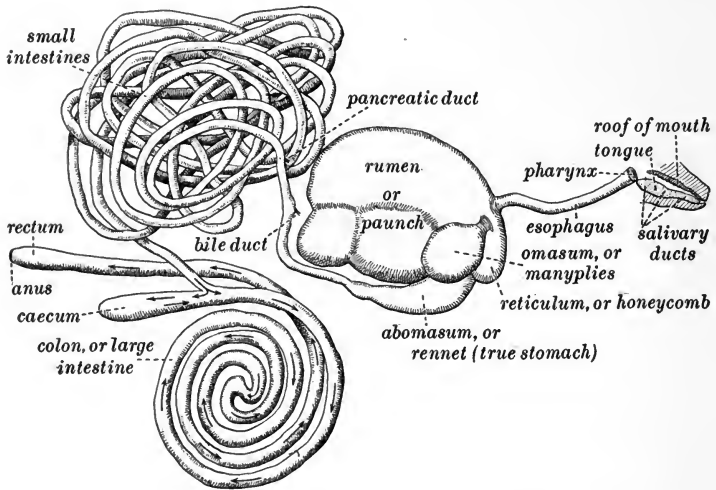

FIG. 162. The digestive tract of a cow. (Diagram from Iowa State College)

believe that they digest their food or secure nourishment from it any more completely than do the unimproved sorts.

**419. Digestibility of feeds.** Some foodstuffs are more easily digested than others. Milk, for example, is easily digested. Grains and other foods like bran and linseed meal are comparatively easily digested. Coarse, woody fodders, like corn stover or wheat straw, are digested very incompletely and with great difficulty. Indeed, in masticating and digesting some very poor materials more energy is required than the materials yield when digested. Therefore the more of such material an animal is forced to consume, the less it is nourished.

Animals when heavily fed digest their feed less completely than when fed a smaller amount. Rations containing too large a proportion of starch or too small a proportion of protein are often less completely digested than are those which are properly balanced. Thus the addition of cottonseed meal or linseed meal to a ration of corn and corn stover, or of corn and timothy hay, will increase the digestibility of the entire ration.

**420. Feed and water.** The animal body is composed of water, protein, fat, ash, and a very small amount of carbohydrates. The plants upon which the animal feeds are made up of water, protein, fat, ash, and a large proportion of carbohydrates. When animals are feeding upon plants containing much water, as green grass, roots, or silage, they drink less water than when feeding upon dry feed, like hay and grain. It is of the utmost importance that the animal have plenty of pure, fresh water. Animals can live longer without food than without water. Animals that are growing or fattening rapidly, or that are producing large quantities of milk, or that are hard at work, especially need large amounts of water and need it often.

**421. Protein.** Protein is necessary in building the vital working organs of the body, in building the muscles, bones, skin, horn, hoofs, hair, and wool, and also in the production of blood, egg, and milk. Without protein animals cannot even be maintained—much less grown. Protein is the most expensive of our food constituents and should be used only for those purposes for which a cheaper substitute cannot be found. The amount of protein to be given an animal will be determined by what the animal is doing (Fig. 163). If the animal is merely being maintained, as in the case of idle mature stock, only the amount of protein required to restore the daily waste of body tissue is needed. If the

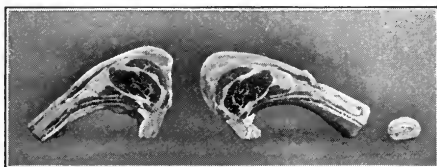

FIG. 163. Good protein feed is necessary to make meat of this fine quality

animal is growing rapidly a much larger quantity will be required for the new tissue to be built as well as for old tissue to be repaired. Cows in milk and laying hens require much protein, because eggs and milk contain much protein.

**422. Sources of protein.** All protein feeds are not of equal value. Animal proteins<sup>1</sup> are generally more completely and more easily used than are the proteins of vegetables. The poultry man knows that laying hens will do better if given skim milk or meat-meal along with the usual grains and green feed. In fattening calves for the show, milk in abundance is used. Skim milk and tankage, with grain, force pigs to the limit of their capacity.

There is a great variation in the value of different vegetable proteins. A part of the protein of corn is incapable of producing growth in young animals and is called an incomplete protein. This probably explains why young pigs confined in a dry lot and fed exclusively on corn soon become unthrifty and sometimes die of starvation, although they have all the corn they will eat. Most coarse feeds are low in protein, but the hays made from the legumes are relatively rich in protein which is of good quality. Thus colts, calves, and lambs when fed on corn and wheat straw or millet or timothy or prairie hay grow slowly, or cease to grow, and soon show a general lack of thrift; while those fed on corn and on hay made from legumes grow rapidly.

Wool production is stimulated somewhat by the addition of protein to the ordinary farm ration. The coat of hair of horses, cattle, and hogs is lustrous and silky when protein is fed liberally and is pale and harsh when protein is deficient in the ration. A larger and stronger bone is produced when plenty of protein of the proper sort is combined with sufficient mineral ingredients. Without protein in abundance the minerals are ineffective in bone building. The protein supply presents one of the principal problems connected with proper feeding of animals.

<sup>1</sup> Proteins that have been worked over and organized as a part of the animal body, such as milk, eggs, dried blood, meat, meat-meal, and tankage.

**423. Carbohydrates.** These substances include the sugars and starches and also the cellular walls of plants called cellulose or crude fiber. The cereals, such as wheat, rye, barley, and corn, and such crops as kafir, milo, and sorghum, furnish a preponderance of starchy, or carbohydrate, materials. The fat in the animal body, in the milk, and in the wool is made for the most part from carbohydrates and crude fiber. Starch is first changed into soluble sugars, and the sugars are then conveyed in the blood to the tissues, where they are used to give energy, or where the various enzymes convert them into fat.

**424. Fats.** Most feeds contain more or less fat or oil. Fat may furnish energy for work or may be stored. It is not, however, stored in quite the same form in which it occurred in the plant. Each species of animal makes its own special sort of fat. We all recognize the difference between mutton tallow and butter fat and the difference between the oily fats of the hog and the hard, tallowy fats of the beef steer.

The fats have a higher nutritive value than the sugars or starches. A pound of fat when burned produces about two and one-fifth times as much heat as does a pound of starch. Therefore fats are estimated to be two and one-fifth times as valuable as starches as a source of energy.

**425. Mineral nutrients.** The mineral elements furnish building material for the body and add palatable, laxative, and stimulative properties to the ration. They also furnish essential constituents for the digestive juices. Calcium furnishes about 70 per cent of the mineral elements that enter into bone, phosphorus more than 27 per cent, and magnesium about one half of 1 per cent. Eggshell is almost pure calcium carbonate. Most cereals are deficient in calcium. This is especially true of corn, and the young growing pig or lamb is unable to secure enough calcium from corn. Phosphorus is another mineral element which is used in the building of bone, and for rapidly growing animals many cereals are deficient in this element. Potassium is another element especially important in the soft tissues.

The common materials that are rich in minerals are milk, meat-meal, tankage, alfalfa, clover, rape, blue grass, bran, wood ashes, bone meal, and limestone.

**426. A balanced ration.** Animals require protein, carbohydrates, and ash, in varying amounts and proportions. A balanced ration has the proper proportion of protein, carbohydrates, and ash to serve the particular needs of the animal. The question is constantly presenting itself as to the source of proteins to balance the cereals and hays, which contain too large a proportion of carbohydrates to meet the needs of animals that are growing, working, or producing meat, milk, eggs, or wool. Skim milk, meat-meal, or tankage from the packing houses are familiar forms of animal protein; and cottonseed meal, linseed-oil meal, bran, middlings, alfalfa hay, clover hay, peanuts, rape, soy beans, and cowpeas are common sources of vegetable protein. The locality in which one lives usually has its own particular economical protein feedstuffs.

**427. Why animals fatten.** When the animal has the chance to eat more food than is required for maintenance and for the production of new muscle, bone, skin, and hair, it usually stores this food in the form of fat and may use it later when food may be scarce. When the animals were running wild their store of fat was the only protection they had against hard times.

Man consumes large quantities of fat for food. Since the earliest times he has used various vegetable oils, such as olive oil, for this purpose. When man learned how to grow grain in large quantities he soon took advantage of the fat-producing power of domestic animals. Strains or breeds were developed which were specially capable of producing fat in large quantities and economically. Dairy cows capable of producing their own weight of butter fat in a single year were developed. Many breeds of so-called lard hogs were developed. Strains of beef cattle capable of fattening very young have been produced.

The greatest development in fat production has been within very recent years, since corn production has been so extensively developed, corn being the greatest fat-producing grain known.



## QUESTIONS AND PROBLEMS

1. What is maintenance and what part of the food is required for this purpose?
2. How may the maintenance cost of our farm animals be reduced?
3. To what productive uses do farm animals put their feed? Give examples from your own observations.
4. What is meant by digestion of food?
5. How and where does digestion occur?
6. How and where does the digested material enter the tissues?
7. Of what is the animal body composed and in what respect does it differ from the plant?
8. Describe the sources and needs of water, proteins, fat, and ash.
9. What is meant by a balanced ration? Give examples for different kinds of animals.
10. How do fowls compare with cattle and with horses in the matter of mastication and digestion of feed?
11. In what sense are the four stomachs of the ruminants a commercial asset?
12. What is the effect of a balanced ration on completeness of digestion?
13. What are the best available feeds with which to balance the cereals?
14. In what sense is the animal a more efficient machine than any that man has yet devised?
15. Why do young pigs confined in dry lots and fed exclusively on corn soon become unthrifty or die?
16. Why do colts, calves, and lambs when fed on corn and wheat straw, or millet, or prairie hay soon cease to gain and show lack of thrift?

## REFERENCES

- BAILEY, L. H. *Encyclopedia of American Agriculture*, Vol. III, pp. 56-119. The Macmillan Company.
- HENRY, W. A. *Feeds and Feeding*. Published by the author.
- JORDAN, W. H. *The Feeding of Animals*. The Macmillan Company.
- SMITH, H. R. *Principals of Stock Feeding*. Webb Publishing Company.
- The Feeding of Farm Animals*, *Farmers' Bulletin 22*, United States Department of Agriculture.
- The Computation of Rations for Farm Animals by the Use of Energy Values*, *Farmers' Bulletin 346*, United States Department of Agriculture.



## CHAPTER XXIX

### HORSES AND MULES

So did this horse excel a common one  
In shape, in courage, color, pace and bone.  
Broad breast, full eye, small head and nostril wide,  
High crest, short ears, straight legs and passing strong.  
Look, what a horse should have he did not lack. — SHAKESPEARE

**428. Importance of horses.** There are one hundred million horses in the world, of which one fifth are in the United States. There are also eight and a quarter million mules in the world, half of which are in the United States, principally in the southern and south-central states. The American farmer employs more labor-saving machinery and uses more horse power than does any other farmer. The scale of intelligence and the income of the farmers of the world are largely associated with these factors.

**429. Early history of the horse.** The Arabians were the first people to develop the horse to a high degree of excellence. They used their horses for riding long distances at a rapid rate, and frequently required them to go many hours without food or water. Under such conditions only the hardest survived. Moreover, the horse was the Arab's only companion much of the time ; consequently the horse most sought was the one possessing the greatest degree of intelligence and most capable of being a good companion. Thus the Arabian horse has long been noted for its endurance, courage, intelligence, and friendly disposition.

The draft type of horse, or Flemish horse, was developed in the low country of northwestern Europe. From the Flemish horse have come all our types of heavy horses (Fig. 164). These two races—the one light, active, and extremely intelligent; the other heavy, slow, of average intelligence, but with

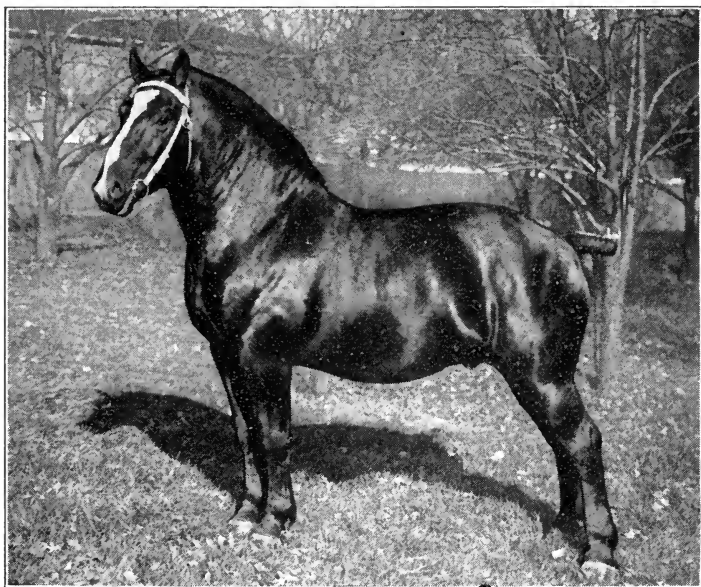

FIG. 164. Combining strength, beauty, endurance, and intelligence  
The Percheron stallion "Idlefonse," champion at the International Live Stock  
Exposition, 1913

good dispositions— have furnished the foundation for nearly all breeds of modern horses. Different parts of the horse (Figs. 165 and 173) have been developed with special reference to the different uses to which they have been put.

**430. The Arabian horse.** The Arabian horses were the first to be known as a breed. They are from 14 to 15.2 hands<sup>1</sup> in height, and weigh from 850 to 1000 pounds. In color they are

<sup>1</sup> A hand is four inches.

bay, brown, chestnut, and occasionally black or gray. They possess good action and great intelligence.

**431. The Thoroughbred.** The next breed to become well established was the Thoroughbred, or the running horse. This breed is native to England and is an offspring of the Arabian horse, modified in part by the demand of the English people for a race

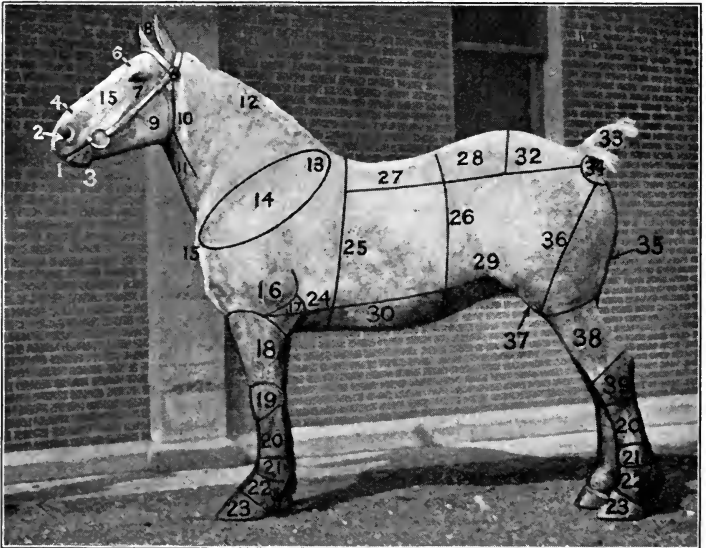

FIG. 165. The points in judging a horse

1, mouth; 2, nostril; 3, chin; 4, nose; 5, face; 6, forehead; 7, eye; 8, ear; 9, lower jaw; 10, throatlatch; 11, windpipe; 12, crest; 13, withers; 14, shoulder; 15, breast; 16, arm; 17, elbow; 18, forearm; 19, knee; 20, cannon; 21, fetlock joint; 22, pastern; 23, foot; 24, fore flank; 25, heart girth; 26, coupling; 27, back; 28, loin; 29, rear flank; 30, belly; 31, hip; 32, croup; 33, tail; 34, buttocks; 35, quarters; 36, thigh; 37, stifle; 38, gaskin, or lower thigh; 39, hock. (Photograph from Purdue University)

horse. It ranges in height from 14.2 to 16.2 hands, and weighs from 900 to 1100 pounds. The colors are bay, brown, chestnut, with a considerable number of blacks and grays. It possesses great running speed and is intelligent, but is very mettlesome and sometimes difficult to manage. This breed has contributed to the improvement of our present-day horses, notably

the American trotters (Fig. 166), saddlers, Morgans, and the European breeds of coach horses.<sup>1</sup>

**432. The Standard Bred horse.** The Standard Bred horse was the first American breed of horses to become established,



FIG. 166. The American trotting horse

This picture is of the most prominent early horse of the American trotting breed. He is Rysdyk's Hambletonian 10 F. This photograph was taken when the horse was 23 years old

and was developed for pleasure, speed, and general utility. The native English horses early brought to America formed the foundation stock. The Standard Bred horses are the fastest

<sup>1</sup> The Hackney, which is the English carriage horse; the French Coach Horse, which is the carriage horse of that country; the German Coach Horse, which is the carriage horse of Germany; and the heavier coach breeds of England, such as the Cleveland Bay and the Yorkshire, have been brought to this country in considerable numbers, but their influence upon the American horse has been limited.

harness horses in the world, have very true, well-balanced action, and possess remarkable endurance and great intelligence. In height they vary from 14 to 16.2 hands, and in weight from 900 to 1200 pounds. Their colors are usually bay, brown, chestnut, or black, and there are a few grays and roans. Standard Bred horses travel at a trot or pace, and some are also able to travel at both gaits and are known as double-gaited horses. The pacing gait is the faster of the two.

**433. The Morgan horse.** This breed is a branch of the Standard Bred horse and was founded by Justin Morgan, a horse of Thoroughbred ancestry. These horses were developed in Vermont and New Hampshire early in the nineteenth century. They are small, ranging in height from 14.3 to 16 hands, and weigh from 950 to 1150 pounds. Their colors are usually bay, chestnut, brown, or black. They possess neither extremely high action nor great speed, but are noted for their endurance, intelligence, and good dispositions.

**434. The American Saddle Horse.** The Americans were the first people to develop a distinctive breed for saddle purposes. The Saddle Horse was developed in Kentucky, Tennessee, Missouri, and Virginia, for the use of men who operated large plantations (Fig. 167). The American Saddle Horse stands preëminent as a riding horse and also as the most beautiful and most versatile of all horses. This horse ranges in height from 15 to 16 hands, and in weight from 900 to 1200 pounds. The colors are black, bay, brown, or chestnut, and there are some grays and roans. They possess fine style and action, and have beautiful heads, long, well-arched necks, and beautiful tails well carried. They are required to perform at five gaits—the walk, the trot, the canter, the rack, and either the running walk, the fox trot, or the slow pace.

**435. The Percheron.** This is the most popular and the most widely distributed draft horse in the United States. The breed originated in the small district in northwest France known as La Perche, and was developed from the native horses (which possessed some Flemish blood), with the infusion of Arabian

blood which the French government brought to the district in 1820. The individuals weigh from 1600 to 2200 pounds, and range in height from 15.3 to 17 hands. The usual colors are gray and black, but others are chestnut, bay, brown, and roan. The Percherons are intelligent, have good dispositions, and

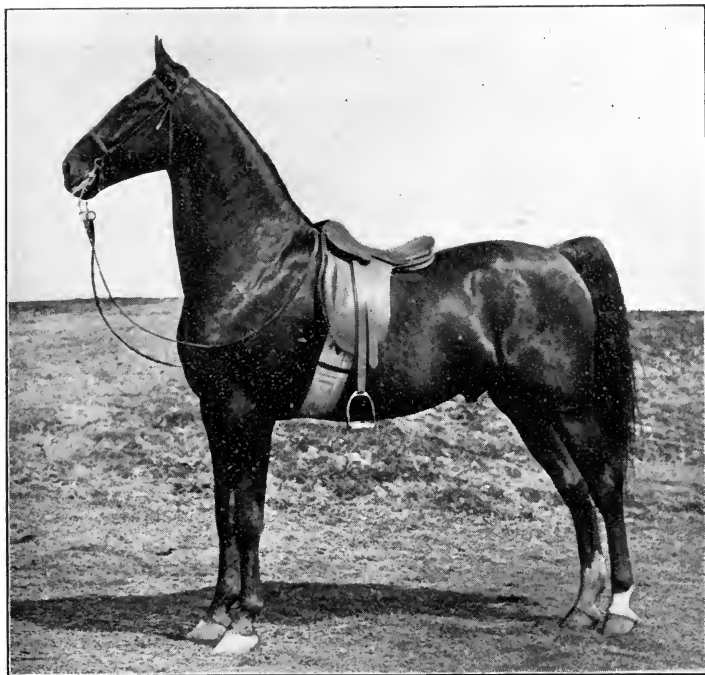

FIG. 167. The American Saddle Horse

possess average style for draft horses, with sufficient action for their weight. Among other French breeds are the Boulonnais, Nivernais, Bretons, and Ardennais, none of which are well known in America. All of these breeds are known as French Draft Horses.

**436. The Belgian.** The Belgian horse is rapidly gaining in popularity in America (Fig. 168). It has been developed from the old Flemish horse with very little, if any, admixture of

other blood. The horses range in height from 15.3 to 17 hands, and in weight from 1600 to 2400 pounds. The colors are chestnut, brown, roan, black, or gray. The Belgian horse is of compact type and has a very wide, deep body and extremely heavy muscles. Every point of its stolid body and of its conformation indicates unusual strength and endurance.

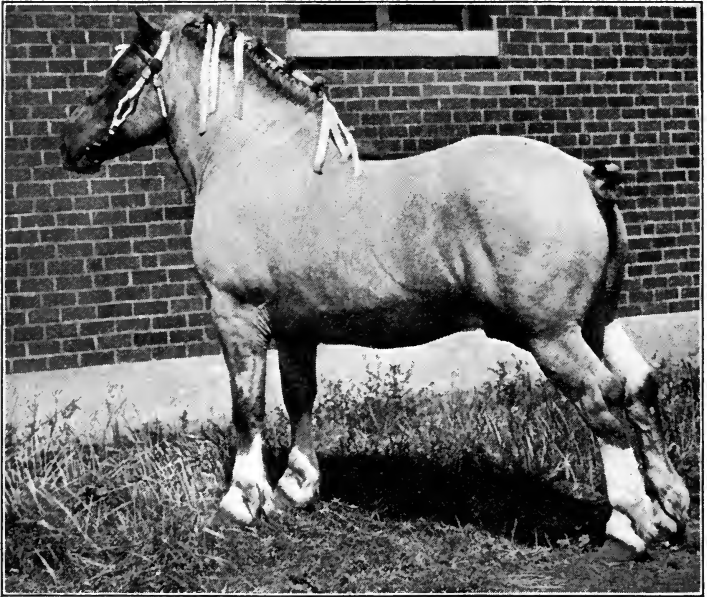

FIG. 168. The Belgian horse

"Pole Nord," the champion Belgian stallion, International Live Stock Exposition, 1913

**437. The English Shire.** The English Shire (Fig. 169) is native to the low-lying counties of east-central England. The Flemish horse intermixed with the native horses of England has produced this breed. This horse and the Belgian are the largest of the draft breeds. The Shire ranges in height from 16 to 17.3 hands, and weighs from 1700 to 2400 pounds. The colors are black, brown, bay, gray, roan, and chestnut, and in most cases these horses have white on feet, legs, and head.



They have heavy muscles and bones. They possess a heavy growth of hair, or *feather*, upon their legs, which is not found in any other draft breed except the Clydesdale.

**438. The Clydesdale.** The Clydesdale (Fig. 170) is a native of Scotland, and was developed from the mingling of the black Flemish with the native horse. These horses stand 16 to 17 hands in height, and weigh from 1600 to 2200 pounds. The breed has the truest and most sprightly action of any of the draft breeds. The colors are brown, black, bay, roan, chestnut, or gray. White faces and white feet are more common markings among the Clydesdales than among the Shires.

**439. Ponies.** Shetlands are the most prominent breed of ponies. They are natives of the Shetland Islands, and have been brought to America in large numbers. Their chief characteristic is their good disposition, which makes them safe for children to ride and drive. They are very hardy and require small quantities of feed. The standard height is 42 inches, and the range of color is wide. The Welsh ponies are natives of the mountain district of Wales; they are very hardy and have considerable speed and action. They are larger than Shetlands, averaging from 12 to 14 hands in height.



FIG. 169. The English Shire

**440. Mules.** The mule is a hybrid, having a mare for its dam and a donkey for its sire. It differs from the horse in that it shows many of the characteristics of its paternal ancestors, having longer ears, a Roman nose, small feet, and clean limbs, with only a coarse, scanty growth of hair on the tail and mane (Fig. 171). The mule is smaller than the draft horse, being

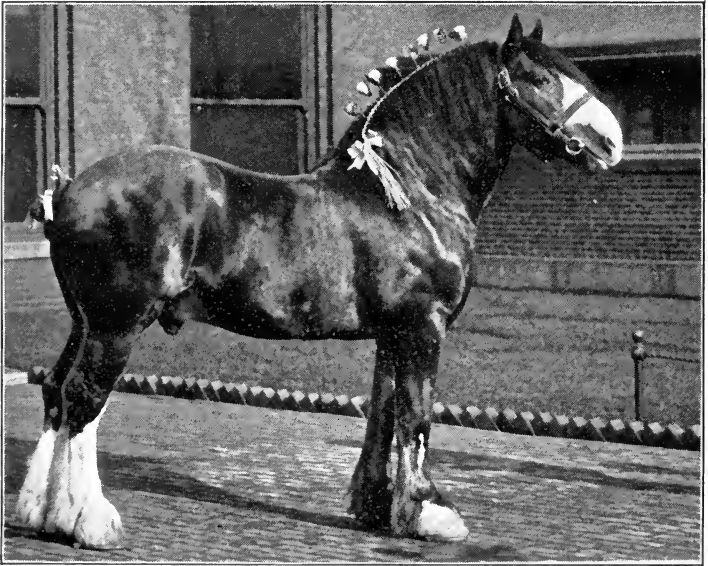

FIG. 170. Champion Clydesdale stallion, International Live Stock Exposition, 1913

from 14 to 17 hands in height and weighing from 800 to 1500 pounds. It is hardy and possesses the faculty of being able to take care of itself. On this account the mule is a very satisfactory animal to place in the hands of the less intelligent farm laborers. In color it is bay, brown, gray, or dun. The color most desired is black, with a tan nose and flank. Texas, Missouri, Kentucky, Georgia, Tennessee, Mississippi, Oklahoma, Arkansas, and Kansas are the principal producers and users of mules. The mule is the principal work animal in the cotton states.

**441. Feeding the horse.** Some horses are what is termed "easy keepers," which means that they require a comparatively small amount of feed and are always in good condition. This

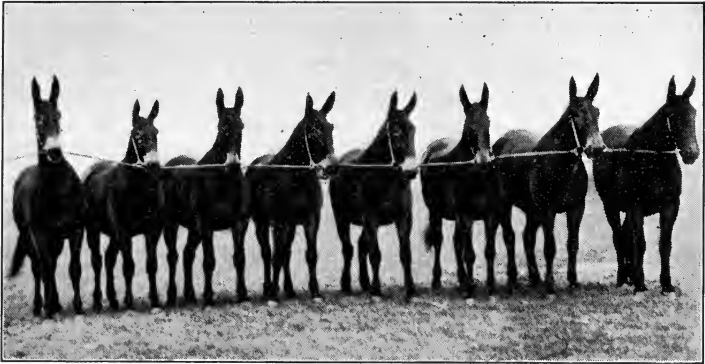

FIG. 171. A prize-winning string of mules

quality is usually associated with a quiet disposition and good digestion. Horses that require a large amount of feed for a given service are usually lacking in quality (Fig. 172). They are of a nervous temperament and have a tendency to "bolt"

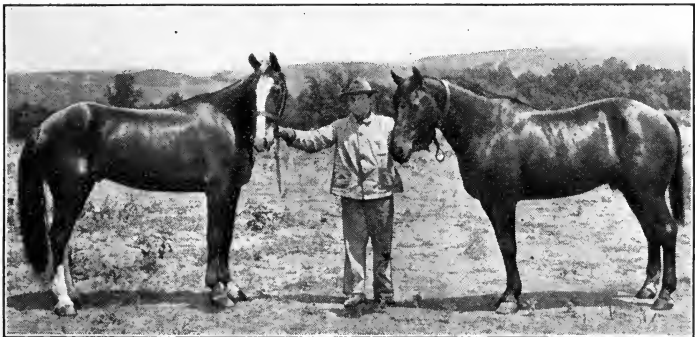

FIG. 172. Good and poor endurance

These are both army artillery horses. The horse on the right is 28 years old, has been 23 years in army service, and is still a fairly good horse. The one on the left is 6 years old, has been 1 year in army service, and is nearly ready to be discarded. The difference is in quality, conformation, temperament, and ability to utilize food

their feed. In this case, much of the feed passes through the system without being digested because of improper mastication; and much of the energy produced by the digested food is wasted in useless fretting.

**442. Adapt the feed to the digestive habits.** Compared with other farm animals, the digestive tracts of the horse are limited in capacity. The digestive apparatus of the horse is also more delicate than that of the hog, ox, or sheep, and as a result digestive disturbances are more common among horses than among the other animals named. The proper feeding of the horse, therefore, requires greater intelligence and more care than the feeding of any other domestic animal. It is necessary to feed horses frequently and in moderate quantities, with food that is palatable and of medium bulk.

**443. The standard horse ration.** The standard horse ration of the country is oats and timothy hay or prairie hay, or a combination of oats and corn and a mixture of timothy and clover hay. Besides possessing the necessary nutrients in about the proper proportions, these foodstuffs are usually free from dust and have the proper bulk. However, oats and timothy hay have become so expensive that there is a constant demand for a ration that will serve the purposes equally well and be cheaper. For horses that are idle or working moderately, many combinations can be made that are quite as efficient and much cheaper. For the brood mares and growing horses, better rations than the standard ration are readily available. For the light horse that is required to make long, hard drives, and for the city horse hard at work, no entirely satisfactory substitute for oats and timothy or prairie hay has been found.

**444. Most farm feeds are suitable for horses.** For idle and moderately worked horses and mules, any of the common feeds produced on the farm may be fed, provided they are palatable, clean, and sound, and the proper balance between protein and carbohydrates is maintained. The best and most economical rations are composed of mixtures of a number of feeds. Horses and mules, when fattening, relish a wide variety of feeds.

Corn is the cheapest horse feed known. More units of work can be produced for less money with corn than with any other grain. It is fed extensively to horses and mules and its use as the basis of the ration is increasing. Liverymen maintain that corn-fed horses cannot withstand the summer heat well. Corn also lacks the proper bulk and is more likely than oats to cause digestive disturbances when fed carelessly or unintelligently.

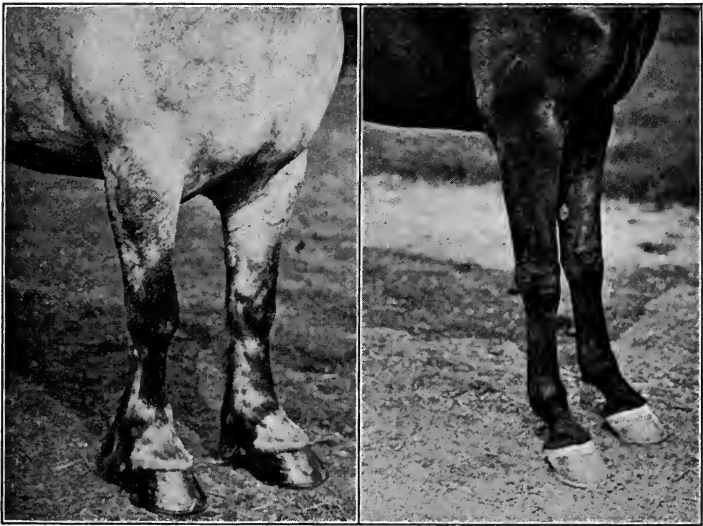

FIG. 173. Strength and speed

The broad, muscular breast, heavy muscles of the arm and forearm, large, well-supported knees, short cannons, strong fetlocks and pasterns, and large, sound feet, all indicate pulling power. The deep chest, long, lithe muscles, clean joints, long cannons, and long pasterns and tough feet indicate speed and endurance. (Photograph from Purdue University)

A mixture of oats and corn is to be preferred to either grain fed alone, unless the price of oats is too high. In that case, corn may be supplemented with oil meal, cottonseed meal, wheat bran, alfalfa, clover, or cowpeas. Wheat bran is used extensively for horses and mules and is usually fed with corn or oats. Because of the high mineral and protein content of wheat bran, it is very valuable for growing horses, but should not be fed in

large quantities, because of its somewhat laxative quality. Shorts and middlings, if fed alone, form a pasty mass when mixed with saliva and do not furnish sufficient bulk. When middlings are sprinkled on chopped hay or straw, the results have been satisfactory, but their use is not common. Linseed meal and cottonseed meal are good protein supplements to rations for horses. If fresh and pure, either of these by-products may be fed to horses and mules up to one and one-half pounds daily or may compose one eighth of the grain ration. Rye, ground or rolled,

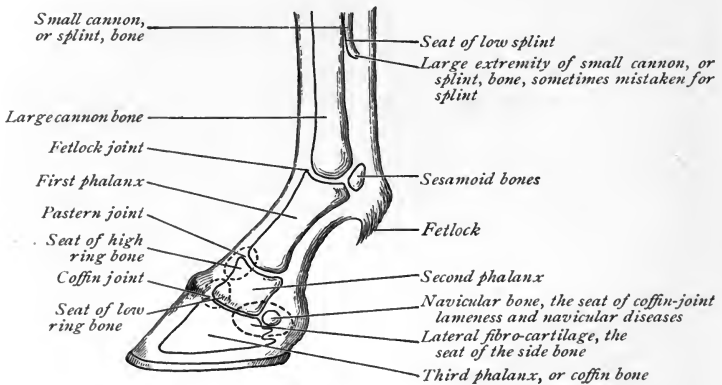

FIG. 174. The structure of a horse's leg in relation to defects and diseases

and combined with barley and oats, is a good horse feed and is used extensively for this purpose in countries where it is the principal grain grown.

**445. Roughage.** Mixed clover and timothy hay is excellent for horses. Clover hay when clean and well cured is a good feed for all kinds of horses and mules, except those doing rapid work. It is especially valuable for colts and brood mares. Clover hay frequently contains dust, which affects the horse's breathing and lessens his endurance. Alfalfa hay resembles clover, but contains more protein. In the regions where alfalfa is grown it is fed extensively and with good results to all ages and kinds of horses and mules. In the humid regions, and especially among

liverymen, there is some prejudice against alfalfa on account of the general belief that it overworks the kidneys. A part of this prejudice is no doubt due to the fact that too much alfalfa is fed, and part is due to the fact that the hay was harvested too green. Alfalfa, to be fed to horses, should be cut when the plant is in full bloom, or later than for cattle, sheep, or hogs. Cowpea hay is similar in composition and efficiency to clover and alfalfa, and like them it is a good feed for horses working moderately.

Oat hay, when cut in the dough stage, makes very nutritive and highly satisfactory roughage for horses and mules. Sorghum hay is used extensively in many localities with good results as a horse feed. For fattening mules and horses, it is highly esteemed. Corn stover is a cheap and satisfactory roughage for idle horses. If fed in excess without other

feed it may cause "impaction" and death. If properly balanced with nitrogenous feeds, oat straw may be used as a roughage for horses and mules. Millet hay is not a safe roughage for horses, since when fed in large quantities, or for a long time, it causes swollen joints, lameness, and other serious results. Ordinarily too much hay is fed to work horses, especially to those doing hard work. A horse cannot work to advantage when its stomach is overloaded with hay. About one fourth of the daily allowance

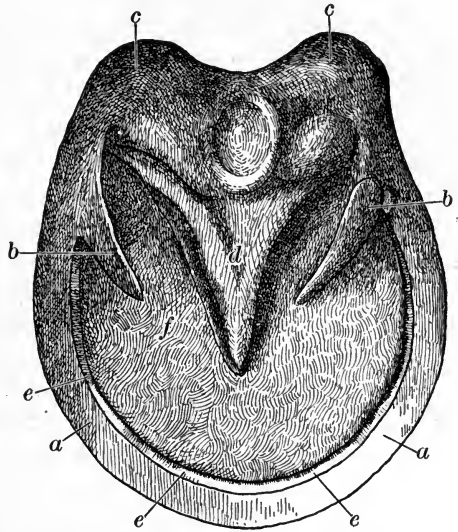

FIG. 175. The sole of a horse's foot

*a*, lower border of the wall; *b, b*, the bars; *c, c*, bulbs of the heel; *d*, the frog; *e*, white line, or place at which horse-shoe nail should enter hoof when a horse is shod

should be fed in the morning, a very little at the noon hour, and the remainder at night. Many transfer and express companies often use no hay at the noon hour.

**446. Silage for horses.** Silage is not recommended as a horse feed except by the most careful feeders. Under no circumstances should moldy silage be fed, as both horses and mules are peculiarly susceptible to the injurious effects of molds, some of which are fatal. Frozen silage is likely to produce colic, and very sour silage is apt to produce digestive disturbances. Silage for horses and mules should be made from relatively mature corn and be wet enough to prevent the growth of molds and should be fed perfectly fresh. If these precautions are taken, silage makes an excellent feed for brood mares, idle horses, and growing colts, and may be fed up to twenty or twenty-five pounds daily for a thousand-pound horse. In all cases it should be fed in connection with a dry roughage.

**447. How much to feed work horses.** A horse at work requires more feed than when idle because it is expending more energy. Enough feed must be given to furnish the energy expended, or the horse will lose in weight. Exact rules for feeding cannot be laid down, but horses working moderately, or colts growing rapidly, will require each day about a pound of grain and a pound of roughage for every one hundred pounds of weight. The condition of the animal is a safe guide. If the animal is becoming thin, increase the feed. If it is becoming fat, reduce the grain. The object should be to keep the work animals in a thrifty condition.

**448. Idle horses need plenty of roughage.** Idle horses have ample time to consume and digest roughage, and therefore do not require large quantities of grain. It is with this class of horses that economy needs most to be enforced. They should, however, be made moderately fat by spring, so that they will be able to do the heavy work of plowing, cultivating, harvesting, and marketing, as during the work season they cannot eat, digest, and assimilate enough to meet the requirements made of them, and to prevent them from becoming poor.



## STANDARD RATIONS FOR IDLE HORSES

(1)	(2)
<i>Grain</i>	<i>Grain</i>
Corn, 8 parts	Corn, 7 parts
Cottonseed meal, 2 parts	Bran, 3 parts
<i>Roughage</i>	<i>Roughage</i>
Clover or alfalfa hay	Mixed clover and timothy hay
Oat straw and sorghum hay	and corn stover
(3)	(4)
<i>Grain</i>	<i>Grain</i>
Corn, 7 parts	Corn, 6 parts
Oats, 3 parts	Bran, 4 parts
<i>Roughage</i>	<i>Roughage</i>
Meadow hay and oat straw	Roots and mixed hay

**449. Feed the colt for bone and muscle.** Growing animals should be kept in a vigorous, thrifty condition but not too fat. Their ration should supply plenty of protein and mineral matter for the development of muscle and bone. Brood mares may be included with this class of animals.

## STANDARD RATIONS FOR COLTS AND BROOD MARES

(1)	(2)
<i>Grain</i>	<i>Grain</i>
Corn, 4 parts	Corn, 6 parts
Oats, 4 parts	Bran, 2 parts
Bran, 2 parts	
<i>Roughage</i>	<i>Roughage</i>
Legume hay and corn stover	Mixed clover and timothy hay
	Corn stover
(3)	(4)
<i>Grain</i>	<i>Grain</i>
Corn, 6 parts	Corn, 7 parts
Bran, 3 parts	Linseed meal, 1 part
Cottonseed meal or linseed meal, 1 part	
<i>Roughage</i>	<i>Roughage</i>
Legume hay	Corn stover
Corn silage	Legume hay
Oat straw	Straw

**450. Variety of feeds required for fattening horses and mules.** In fattening horses and mules it is important to supply them with a variety of palatable feeds, so as to induce them to eat as much as possible. It is only by this means that rapid and inexpensive gains can be made. Horses and mules, like all other animals, make rapid, inexpensive gains when thin, and slow, costly gains when nearly fat.

#### STANDARD RATIONS FOR FATTENING HORSES AND MULES

<i>Grain</i>	(1)	<i>Grain</i>	(2)
Corn, 8 parts		Corn, 6 parts	
Oats, 2 parts		Oats, 2 parts	
		Bran, 2 parts	
<i>Roughage</i>		<i>Roughage</i>	
Clover or alfalfa hay		Clover or alfalfa hay	
Sorghum hay and corn stover		Oat straw and corn stover	
<i>Grain</i>	(3)	<i>Grain</i>	(4)
Corn, 9 parts		Corn, 8 parts	
Linseed meal, 1 part		Linseed meal, 2 parts	
Sheaf oats			
<i>Roughage</i>		<i>Roughage</i>	
Clover hay, alfalfa and sorghum hay		Corn silage, oat straw, and timothy hay	

**451. Watering.** Under natural conditions horses remain close to water and drink frequently. The more nearly these conditions can be supplied for domestic horses the better will be the results. Pure water constantly accessible to the animals when at pasture is very important. Opinions differ as to how frequently work stock should be watered and as to whether the water should be given before feeding or after feeding. If the water is given before feeding, some persons believe that too much water will be drunk and not enough feed will be eaten. Others believe that if the water is given immediately after the meal, much of the undigested food will be washed from the

stomach. The prevailing practice among good horse men is to give water both before and after feeding. This insures the taking of water in moderate quantities and prevents gorging. It is unsafe to water horses while they are heated.

**452. Market classes of horses.** The leading horse and mule markets of the United States are at Chicago, St. Louis, Kansas City, Omaha, Buffalo, and Boston. Among the classes which are found on these markets are draft horses, farm horses,

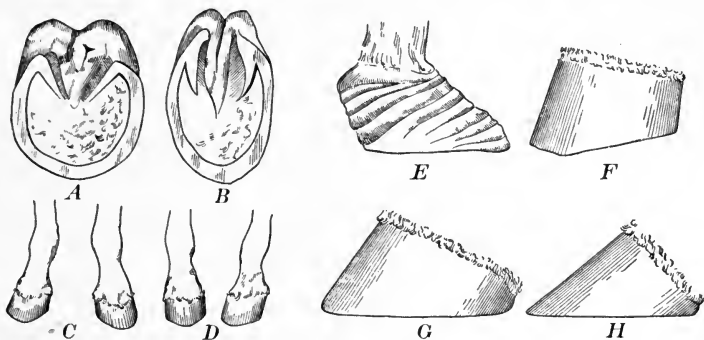

FIG. 176. The points in judging the foot of a horse

*A*, bottom of a regular forefoot; *B*, a contracted foot; *C*, too-wide position; *D*, too-narrow position; *E*, ring building as the result of chronic founder; *F*, side view of an upright foot; *G*, side view of a normal hoof; *H*, side view of sloping toe and low heel

express horses, carriage horses, saddle horses, army horses, and Southern horses.

To sell best on the market, horses should possess quality, strong conformation, and good disposition. They should be fat — first, because they look better and are ready to go into hard work, and second, because buyers take a fat horse as evidence of his good feeding quality and perfect health. Dark, solid colors are preferred. Each year large numbers of horses are sold as “misfits” because they do not belong to any particular class. Such misfits must be sold at a low price. In judging horses at the market many points of good or bad quality are considered. A few of these points with the associated quality are shown in Figs. 165 and 173–176.

**453. A summary of the market classes of horses and mules.** The specifications of each of the market classes are briefly condensed in the following table :

### I. THE HORSE

#### THE HEAVY TYPE

HEIGHT	WEIGHT	GAIT AT WHICH WORK IS PERFORMED	TYPE
	<i>Pounds</i>		
Drafters, 15.3-17.3 hands	1600-2200	Walk	Compact
Farm Chunks, 15.1-16.1 hands	1200-1500	Walk	Compact
Expressers, 15.3-16.2 hands	1300-1550	Slow trot	Slightly rangy
Wagon Horses, 15-16.3 hands	1100-1500	Slow trot	Slightly rangy

#### THE LIGHT TYPE

HEIGHT	WEIGHT	GAIT REQUIRED FOR MOST OF THEIR WORK	ACTION	TYPE
	<i>Pounds</i>			
Carriage horses, 14.3-16 hands	1000-1200	Slow trot	High and stylish	Compact, with well-filled body and with quality
Roadsters, 15-15.3 hands	900-1100	Trot	Fast and easy	Somewhat rangy, with quality and stamina
Five-gaited saddle, 15-16 hands	900-1150	Walk, trot, canter, rack, and slow gait	Easy, stylish, with moderate speed	Much quality and symmetry, with beautiful head, neck, and tail
Three-gaited, 14.3-16 hands	900-1200	Walk, trot, and canter	Easy, stylish, with moderate speed	Much quality and symmetry, beautiful head and neck, with stylishly docked tail

II. THE MULE<sup>1</sup>

HEIGHT	WEIGHT	TYPE
	<i>Pounds</i>	
Draft mules, 15.3-17.2 hands	1250-1600	Compact, with heavy bone and moderate quality and action
Sugar mules, 15.3-17 hands	1100-1500	Somewhat rangy, with style, quality, and action above average
Surface-mining mules, 15.2-16.2 hands	1100-1500	Compact, rugged, with heavy bone and only moderate quality and action
Cotton mules, 14.2-15.2 hands	800-1100	Compact, with good style, quality, and good action
Pit-mining mules, 12-14 hands	650-900	Rugged, with heavy bone and good quality. Must move quickly and easily

## QUESTIONS AND PROBLEMS

1. From the text and from any other available source find out all you can about the early history of the horse, and discuss the subject in class.
2. Prepare a chart on which you list the leading characteristics of the different kinds of horses, as the Arabian, Thoroughbred, and Morgan.
3. Where was the distinctive breed of Saddle Horses developed? What are its characteristics?
4. What are the most important draft breeds?
5. Describe and give the history of the Percheron horse; the Belgian; the English Shire; the Clydesdale.
6. Select any available horse, list his chief characteristics, and decide which breed he most resembles.
7. Try to find and study a horse of each breed mentioned in the text.
8. What are the leading kinds of ponies? How do they differ from other horses?
9. How do mules differ from horses?
10. Why should care be taken to adapt the feed to each horse?

<sup>1</sup> Height is more important in mules than in horses. Like horses, however, mules, to sell best on the market, must fit a given class. They must possess quality, strong conformation, and good disposition, and must be in good condition.

11. What is the standard horse ration in your locality? How does this compare with the standard rations given in this text?

12. Make up from the feeds of your neighborhood a ration suitable for horses working moderately; for horses being driven rapidly; for idle horses; for brood mares; for growing colts.

13. Under what circumstances should silage be fed to horses?

14. What caution should be observed in the watering of horses? in grooming? in blanketing? in clipping? in training young horses?

15. To what leading markets of the world are horses shipped from your locality?

16. Find a horse that is not accustomed to having water offered him before he receives his morning ration. Measure the amount of water he drinks, and on the following day water him before he is fed in the morning and after he is fed as well, noting any difference that there may be in the amount of water taken on the two days.

17. What special care should be taken of the horse's feet? What are the principal defects developed in horse's feet?

18. With the score cards given in appendixes C, D, and E, score (1) a draft horse, (2) a light horse, and (3) a mule.

### EXERCISES

The students' work in judging horses and mules will be greatly helped by a careful study of the illustrations of this chapter, particularly Figs. 165, 173-176. It will also help if two animals of the same class but of very different quality may be selected for study.

1. **Judging draft horses.** Size and weight are determining factors in the classification of draft horses. To belong to this class a horse should weigh 1600 pounds or more and should be at least 15.2 hands high. Value increases with size, other things being equal.

The draft horse should be deep, wide, and compact of body, and should carry his weight uniformly. The top line should be strong and short, while the underlines should be long and straight. Quality is an essential to good service. It is indicated by fine hair; clean, strong joints; clean, flat legs; and tough, firm feet. The head should be cleanly defined and bony in appearance, with good width of forehead.

The head should be proportionate to the body, neither too large nor too small, with clean muzzle, medium ear, bright eye, broad forehead, and a clean throatlatch. A thick throatlatch usually indicates "poor wind." The neck should be of medium length, with a slight

crest, and should be well muscled. The shoulders should be long and sloping, in order to give breaking surface for the collar and to lessen the concussion of hard streets. Good muscular development of arm and forearm is essential. The withers should be of medium height. A back with a close coupling and with a long, heavy-muscled croup is a conformation representing the greatest strength. Long, well-sprung ribs with a deep and well-filled rear flank make room for a well-developed digestive apparatus and strong vital organs. Muscular development of the hind quarters is essential. The draft horse should stand squarely on its legs. The legs should be clean, with bone of good size and with strong joints. The pastern should be sloping, and the hocks should be large and of regular shape.

Constitution is indicated by a deep, broad chest, together with a well-sprung rib, a deep body, bright eyes, and great energy.

The action of draft horses is important. The stride at the walk and trot should be long, straight, and regular. Correct conformation gives elasticity to the walk and the trot in all horses. Reasonable grace and style of carriage are demanded.

The score card is made on the basis of one hundred points. In scoring animals the points of description, conformation, or quality should be stated. The parts which do not conform to the description on the score card cannot be given a perfect score.

**2. Judging light horses.** Style, action, and speed are factors of great importance in determining the value of light horses. They should show medium width and depth of body, and the width should be carried evenly from front to rear. The top line should be strong and short, while the underline should be long and straight. Quality is indicated in the light horse, as in the draft horse, by a fine coat of hair, and by cleanly marked features and joints. Since most of the light horse's work is done at the trot, this gait is important. At both the walk and the trot, the light horse's stride should be long, straight, and regular, showing style and ease of movement. It is not essential that the light horse should have particularly heavy bones.

The head should be symmetrical. The eye should be bright and the ear erect; the neck long, well arched, with a clean throatlatch; the shoulders long and sloping, with withers of good height. The back should be strong and the croup well muscled and not drooping; the tail should be set high and carried in a median line well out from the body. Both fore and hind flanks should show medium

depth. The feet and legs should set squarely under the body, with sloping pasterns and strong hocks.

**3. Judging mules.** Since the mule is essentially a draft animal for use under conditions which demand both strength and agility, the chief points in judging relate to size, weight, and action. The best mules are tall, a little more "leggy" than horses, compact in build, clean-cut in legs, head, and neck, and of good temperament. The points are best set forth in the score card.

#### REFERENCES

- CRAIG, JOHN A. Judging Live Stock. Kenyon Printing Company.  
GAY, C. W. Productive Horse Husbandry. J. B. Lippincott Company.  
JOHNSTON, J. H. S. The Horse Book. Saunders Publishing Company.  
PLUMB, C. S. Types and Breeds of Farm Animals. Ginn and Company.  
The Principles of Horse Feeding, *Farmers' Bulletin 170*, United States Department of Agriculture.  
Horse Shoeing, *Farmers' Bulletin 179*, United States Department of Agriculture.



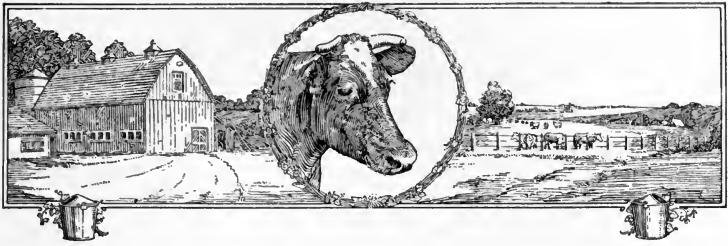

## CHAPTER XXX

### DAIRY CATTLE

That cow is best shaped that is grim looking, with an ugly head, an abundance of neck, with no end of length of her side, and everything large about her down to her foot. — VERGIL

**454. The dairy.** Nearly one tenth of the farm income of the United States is derived from dairy products. The annual income from this source is about \$814,000,000, a larger amount than is received from any other single source except from the corn crop. Our market for dairy products exceeds our supply, and large quantities of butter and cheese are imported from other countries each year.

**455. Advantages of dairying.** A farm used for dairy purposes should gain constantly in fertility, because the feed grown on the farm, as well as that which is purchased. When milk products are sold from the farm only a small portion of the plant food contained in the entire crop is sold. As a means of building up the soil no other system of farming equals dairy farming.

The dairy cow is the most economical producer of human food. Therefore the cow is adapted to high-priced lands and can utilize high-priced feed and labor to advantage. The rental of land on the island of Jersey, the home of the Jersey cow, is from \$50 to \$80 an acre a year. Land in Holland is valued as high as \$1000 an acre, and the chief agricultural pursuit there is caring for the Holstein cow and her products (Fig. 177).

Dairying furnishes immediate and constant returns, and is adapted to farmers with small capital as well as to those with large capital. The price of milk and of butter fat is never subject to great fluctuations, but is more steady and uniform than the price of most other farm products. Keeping dairy cows on the

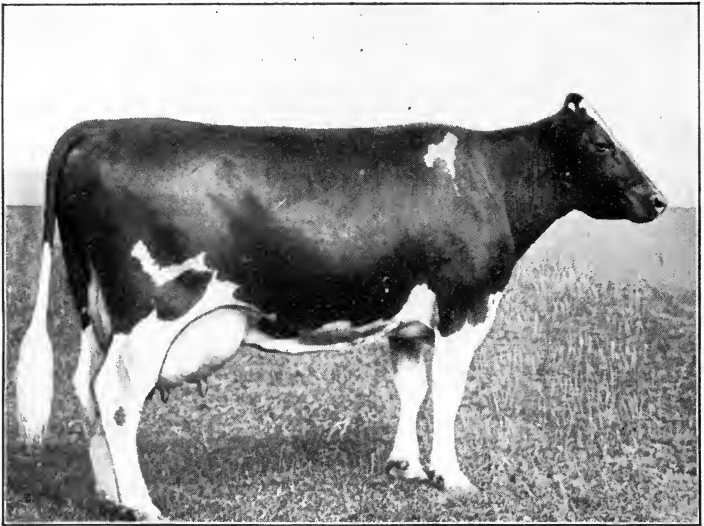

FIG. 177. A lady of quality

The Holstein cow, "K. P. Pontiac Lass," made a world's seven-day butter record by producing 44.15 pounds of butter. She was sold for \$10,000 and was the mother of a bull which brought \$15,000. She was bred and developed by Mr. Francis M. Jones of Clinton, New York, who at the age of 22 years, with scanty means and under great opposition from his relatives and neighbors, began raising pure-bred stock

farm furnishes employment the year round, and this enables the farmer to get a better class of farm labor.

**456. The dairy herd.** The first essential for profitable dairying is good cows. The profitable dairy cow is one that will make the maximum production on the minimum quantity of food. Frequently, good milk cows are found among ordinary scrub cattle or among beef breeds, but such cows are not so likely to transmit their milking qualities to their offspring as are the cows

belonging to the special dairy breeds. No entirely successful dual-purpose<sup>1</sup> breed of cattle has yet been produced. Therefore the greatest profit can be made from special dairy cattle that have been developed by careful breeding and selection through periods of from one hundred and fifty to two thousand years.

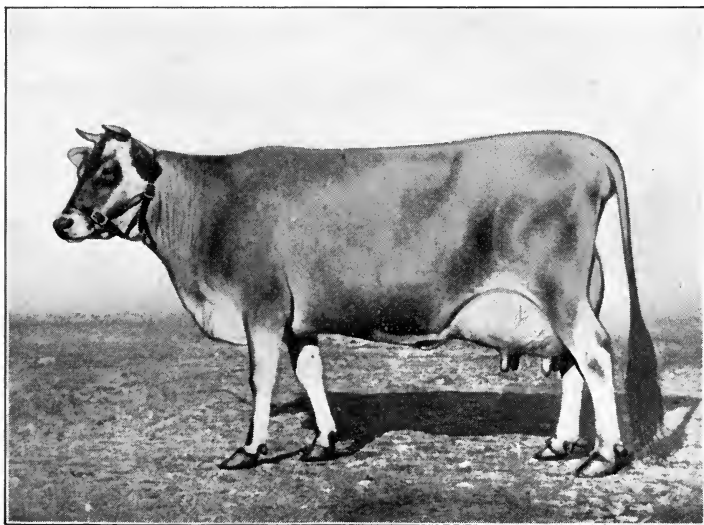

FIG. 178. The world's-record Jersey cow, "Sophia 19th," of Hood Farm Record in 1914: milk, 17,558 pounds; butter fat, 999 pounds. The average cow of the United States produces about 120 pounds of butter fat in a year

The breeds now classified as dairy cattle are Jerseys, Guernseys, Ayrshires, Holsteins, Brown Swiss, Dutch Belted, and Milking Shorthorns.

**457. Jerseys.** The Jersey (Fig. 178) is perhaps the most widely distributed breed of dairy cattle in the United States, as is indicated by the fact that there have been a greater number of this breed registered than of any other breed. The home of this breed is the island of Jersey, the largest in the group of the Channel Islands. The majority of the animals are of a solid color of yellow or gray fawn, with a black nose and black tongue

<sup>1</sup> Cattle that combine the qualities of good dairy and good beef animals.

and switch. However, there are many broken-colored Jerseys, the bodies of which are fawn with white spots. The Jersey is small, the cow, when mature, weighing from 800 to 1000 pounds. The milk of the Jersey is very rich in butter fat, the average test for the breed being about 5.2 per cent. The fat globules in the milk are large, and the butter fat is highly colored and is easily churned. The color and richness of her milk makes the Jersey a great favorite as a family cow. The cows of this breed are very economical producers of butter fat.

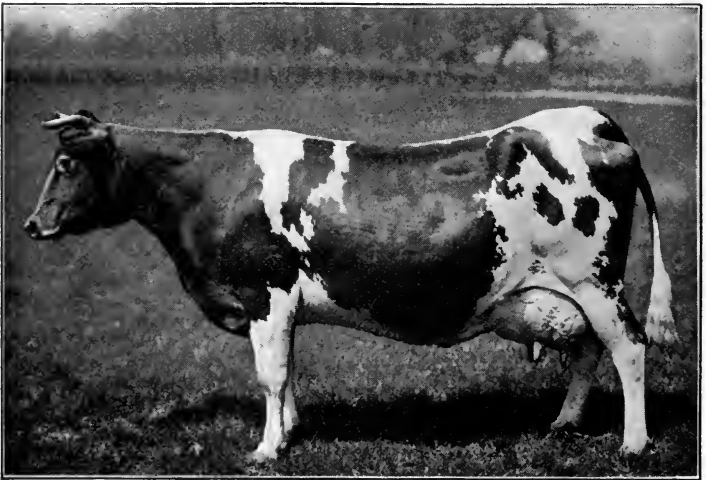

FIG. 179. A world's-record Guernsey, "May Rilma"

In 1914 this Guernsey cow produced 1073.41 pounds of butter fat

**458. Guernseys.** The Guernsey breed (Fig. 179) had its origin on the island of Guernsey, the second largest island in the Channel Island group. Cows of this breed are somewhat larger than the Jerseys, averaging about one thousand pounds in live weight. The characteristics of the Guernsey are somewhat similar to those of the Jersey. The color may be either the solid lemon or orange fawn, or fawn with white markings. They are never gray or black. The nose is buff, and the switch and tongue are generally white. Their milk is not quite so rich

as that of the Jersey, but they give a slightly larger quantity. The milk is noted for its extreme yellow color, and the butter made from the milk has a good color all the year. The Guernsey milk averages about 4.9 per cent butter fat.

**459. Ayrshires.** The native home of the Ayrshire is the county of Ayr, Scotland. The cattle of this breed (Fig. 180) are very strong and thrifty. In size they rank between the

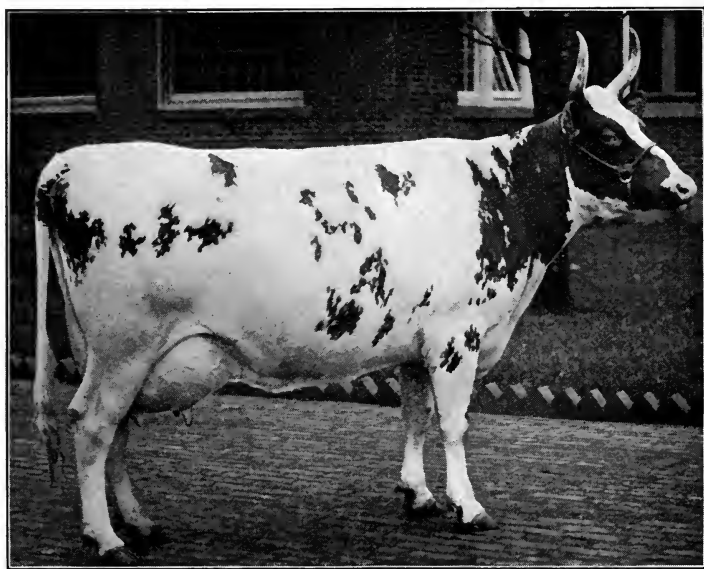

FIG. 180. A grand-champion Ayrshire cow, "Imperial Kilnford Bell 3d"  
Grand champion of all breeds at the National Dairy Show, 1913

Jersey and the Holstein, the average cow weighing about one thousand pounds. In color they may be either a dark red with white, or a light red with white. The red color in the bulls often deepens into a mahogany color. The color of the Ayrshire gives the breed an advantage over the other dairy breeds when offered on the market for beef, as there is a widespread prejudice against the dairy breeds for beef, especially against the Jerseys and Guernseys. In form the Ayrshire does not show the extreme

angular dairy type that is exhibited by high-class Jerseys or Holsteins. It is somewhat smoother over the shoulders, back, and hips, and shows slightly more of the beef type, particularly in the hind quarters. The Ayrshire cow is especially noted for her symmetrical udder. The milk has an average composition of 3.8 per cent butter fat, which makes this breed good for use



FIG. 181. World's-milk-record Holstein cow, "Tillie Alcartra"

Record in 1914: milk, 30,452 pounds. The average dairy cow of the United States gives about 4000 pounds of milk a year

in the production of market milk. These cattle are excellent rustlers and good breeders, and the calves are very strong and healthy.

**460. Holsteins.** The Holstein breed originated in Holland, and has been bred in that region for at least two thousand years. During that time there has been very little, if any, mixing with outside blood. The Holsteins are the largest of the dairy breeds.

Since ancient times Holland has been noted for its butter, its cheese, and its immense oxen. The average weight of the mature cow is about 1200 pounds, but individual cows often weigh as much as 1400 pounds. The color markings of this breed are black and white. As a rule breeders prefer animals on which the colors are evenly divided. The cows have quiet dispositions.

As milk producers the Holstein cows are unexcelled (Fig. 181). They produce more milk, and at less cost per pound, than does

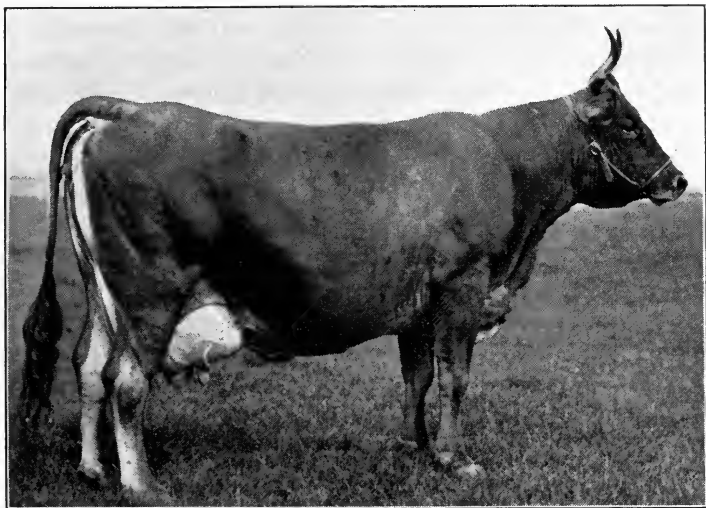

FIG. 182. A typical Brown Swiss cow

any other breed. The milk is not very rich, however, averaging about 3.5 per cent butter fat. For a dairy breed, these cattle rank high as beef producers. The calves are large at birth, grow rapidly, and make excellent veal. The Holstein is well adapted for supplying milk for cities or factories.

**461. Brown Swiss.** The Brown Swiss, as they are known in America, represent one of the leading breeds, which has been developed in Switzerland (Fig. 182). It is probably one of the oldest breeds known. In their native land the Brown Swiss are classed as a dual-purpose breed, and in America were formerly

exhibited both as beef cattle and as dairy cattle, but are now classed as a dairy breed only. The cows average from 1200 to 1400 pounds in weight. The color of the Brown Swiss varies from brown to silver gray, resembling the color of some families of Jerseys. They give a moderate amount of milk containing about 3.7 per cent of butter fat.

**462. Dutch Belted.** This oddly colored breed had its origin in northern Holland, and its development is considered a remarkable accomplishment in the way of breeding. In size these cattle resemble the Ayrshires, but their general conformation is more like that of the Holsteins. The most distinctive characteristic of the Dutch Belted breed is the presence of the white belt around the body. This belt extends around the body from just behind the shoulder to just in front of the hips. The cows are fairly good milkers. The milk contains about 3.5 per cent butter fat.

**463. Milking Shorthorns.** In the development of the Shorthorn breed several noted breeders have paid much attention to the milking qualities. In this way several families of the breed have become celebrated as milk producers. An effort has been made by many breeders to develop a dual-purpose Shorthorn, but so far very little has been accomplished. All Shorthorn cows producing large quantities of milk approximate the dairy type. Their calves sell at a better price for beef than do calves of a dairy breed, chiefly because of their color. There have been a number of Shorthorn cows that have made records of over 600 pounds of butter fat in a year, but such cows are exceptional. It is difficult to find many good Shorthorn milk cows that will transmit their milking qualities with any degree of certainty. The milk of the Shorthorn contains from 3.5 to 4 per cent of butter fat and resembles the milk of the Holstein in color.

**464. Selecting a dairy herd.** A dairy herd may be chosen in accordance with the type, or conformation, of the cows, or in accordance with their records of milk and butter production. The second method cannot be followed very extensively, because



only a small per cent of the cows have records ; therefore the first method is the one generally used. This has led to a study of the type of cow best suited to milk production and to a definite system of judging dairy cattle (see Appendix F).

**465. Keeping records of the cows.** After one has a herd there is no excuse for not knowing what each animal produces and how much feed it has eaten. This is the only reliable way of selecting profitable cows. A cow may rank very high according to the score card and still not be a very profitable producer. By selecting cows on their records, discarding the unprofitable ones, using good sires, and keeping the calves from the best cows, one is certain to increase the productiveness of the herd.

In keeping records of the cows, one must consider the disposition made of the milk and keep the records necessary to determine the profit or the loss on the product sold. One who sells milk regardless of the fat content need only keep a record of the amount of milk produced and of the amount of feed consumed. If the product is sold as cream and payment made on the butter-fat basis, or if the butter is sold, a record should be kept of butter-fat production. The best method of keeping the milk record is to weigh the milk each night and morning.

It is not practicable to make a butter-fat test of each milking ; besides, a composite sample representing the milk of two days each month will give very accurate results. The result obtained by multiplying the number of pounds of milk given during the month by the per cent of fat obtained from the composite sample is the butter-fat record for the month. Since average butter contains about 83 per cent of butter fat, a cow's butter-fat record must be increased by one fifth in order to ascertain her butter record.

**466. How to select a dairy cow.** There is a certain type, or form, of cow that is associated with large milk production. The conformation of the dairy cow differs fundamentally from that of the beef animal. The dairy cow is spare in flesh, angular, and is usually referred to as wedge-shaped, while the beef animal has a square, blocky form.

**467. General appearance.** A high-producing cow appears thin, angular, and loose-jointed. The dairy cow "has three wedges." One wedge is seen when the cow is viewed from the front, one when she is viewed from the side, and one when she is viewed from above. The first wedge mentioned is formed by the withers being sharp and the chest being wide. The tapering depth from the rear part of the barrel<sup>1</sup> and udder to the head and neck forms the wedge as seen from the side. The wedge seen from above is formed by the extreme width through the hips gradually tapering to the sharp withers. The wedge shape is not extremely pronounced in all dairy cows, but in all the best animals such a form is likely to be found.

**468. Quality.** Quality in a dairy cow is indicated by fine hair, by soft, loose, mellow skin of medium thickness, and by a fine, clean bone. Dairy temperament is another essential to good quality. By dairy temperament is meant the ability to convert the feed into milk; this is indicated by a good nervous system well under control. A good temperament is indicated by a neat, refined appearance, by spareness in flesh when in milk, and by a large, full, mild eye. Though spare in flesh while in milk, a good dairy cow may be allowed to carry considerable fat when not giving milk.

**469. The head.** The head should be clean cut, of medium length, quiet in expression, and have a feminine appearance. The eye should be large, bright, and full, indicating strong nervous power and health. A mild expression in the eye indicates a good disposition. The forehead should be slightly dished and broad. The jaw should be strong and wide, tapering somewhat to a strong, broad muzzle. A large muzzle and a strong jaw are indications of a good feeder. The ears should be of medium length, good texture, and fine quality, with an abundance of orange or yellow color inside. The neck should be moderately long, thin, and muscular, with clean throat and light dewlap. The neck of the typical dairy cow joins the body abruptly, and not as neatly as does the neck of the beef animal.

<sup>1</sup> Abdomen.

**470. Fore quarters.** The shoulder should be well muscled, sloping, narrow, and open at the withers. A wide, deep chest is associated with large lung and heart capacity, so essential to a strong constitution, to good respiration, digestion, and production in any kind of an animal. The fore legs should be short, fine, and straight.

**471. Body.** The heart girth should be large, indicating large lung and heart capacity. The back should be long, strong, and loose-jointed, but not necessarily straight. The spaces between the vertebræ should be wide and open, indicating width of rib. The ribs should also be long and far apart. The abdomen, or barrel, should be long, wide, and deep, especially just in front of the udder. A cow must have large capacity to be an economical producer, for she must eat and digest large quantities of food. Often a cow will not show great depth of barrel but may have a large capacity for food by having a greater width of barrel and greater spring of ribs. A strong jaw, keen eye, large muzzle, and capacious barrel are the indications of ability to consume and digest large quantities of food. The loin should be broad and strong, with roomy coupling.

**472. Hind quarters.** The hind quarters should show the leanness characteristic of the other parts of the body. The hips should be far apart, prominent, and level with the back. The rump should be long and wide, with a roomy pelvis; the pin bones, high and wide apart. The thighs should be long, thin, and wide apart, with plenty of room for the udder. The legs should be fine, straight, and far apart.

**473. Udder.** The udder is the gland or milk factory where the nutrients are taken from the blood and made over into milk. The udder is largely used as an index of the ability of the cow as a producer. It should be capacious, free from flesh, and when empty should be soft and flexible. Capacity in the udder should be gained by length and width rather than by depth. The udder should be attached to the body high behind and far forward and should show good width throughout. This form affords ample surface for the blood vessels to spread as they

pass through the udder. The milk veins serve as an index to the amount of blood that flows through the udder. These veins carry blood from the udder back to the heart. They pass inward about midway between the hind and fore legs. The milk wells, or openings, through which the milk veins enter the body, should be large. There may be more than one milk well on each side of the body, as the milk veins branch in some cases after leaving the udder. Cows have been known to have as many as five milk wells on each side. The quarters of the udder should be even in size and not divided far up, but the base, or sole, of the udder should be flat. The teats should be even, of good size for milking conveniently, and set squarely on each quarter of the udder. The hair on the udder should be fine and soft, indicating quality.

**474. The selection of the herd bull.** The future development of the herd depends to a great extent upon the kind of sire used. The sire is half the herd. He should be pure bred and be backed up by good ancestry. If possible, one should seek a sire whose mother, or other close female ancestry, have good records of production. If it is not possible to know the record of production, one should by all means see the mother of the sire and note how closely she conforms to the dairy type. If the sire's father has daughters that have proved to be good producers, he is more certain to transmit the dairy qualities desired. Very often it is possible to buy an old sire who has proved to be a good breeder.

**475. Feeding the dairy herd.** To obtain satisfactory returns from even a well-selected or well-bred herd, the animals must be fed properly. A cow is merely a machine for converting feed into milk and butter. Nature teaches us how the cow should be fed. The cow does her best work in May and June, when she is receiving nature's ration — grass in its choicest form. Food is at hand in abundance ; it is palatable, balanced, and easily digested. The cow herself is comfortable. The intelligent feeder will strive to approximate these conditions as nearly as possible throughout the year.

**476. When the pastures fail.** Therefore, when the pastures become dry, or short, they should be supplemented with some green crop such as corn, oats, and Canada peas, sorghum, green alfalfa, or silage. It is very important that the flow of milk be kept up, as it is difficult to "bring a cow back to her milk" once the milk flow has been allowed to decline.

**477. How much to feed.** As winter approaches, the conditions that prevailed in early summer must be provided by the feeder. The first condition to be looked after is that of furnishing an abundance of palatable feed. It is a poor practice not to give a cow the amount of feed required to produce all the milk she is capable of producing. The effect of underfeeding may not be noticed at once, because a cow will produce milk for a time at the expense of her body; that is, some of the surplus fat and flesh of her body will be converted into milk. If a cow declines in weight while producing milk, it shows that she is being underfed. A cow that is overfed will soon reveal the fact by becoming fat or getting "off feed." All cows in the ordinary herd are usually given the same amount of feed. Under such conditions, some cows are overfed, while others are underfed, but underfeeding is more common than overfeeding.

**478. Feed silage or roots in winter.** Another condition of summer feeding which should be closely maintained during the winter is that of providing a succulent ration, such as silage or roots. Such feed has a value in addition to the nutrients it furnishes. It serves to keep the digestive organs of the animal in good condition and possibly aids digestion.

**479. Feed a bulky ration.** The main object in formulating a ration, after selecting the feeds to be used, is to provide a sufficient bulk at all times to satisfy the appetite and feeding capacity of the animal and to furnish the amount of nutrients needed for the work the cow is doing. If the ration lacks bulk, the cow will be "discontented." A cow should have all the roughage she will eat at all times, and the richer the roughage, the larger the amount of grain which will be saved, and the more the energy of the cow will be conserved.

**480. How much grain to feed.** The grain ration should be regulated by the amount of milk produced. The rule of feeding 1 pound of grain for each 3 or 4 pounds of milk produced is fairly safe. A cow giving rich milk should be fed 1 pound of grain to 3 pounds of milk produced, while a cow giving low-testing milk should have only 1 pound of grain to 4 pounds of milk.

The dairy ration should be home grown in so far as possible. The rest of the protein needed for balancing the ration is usually supplied in the mill feeds, such as bran, cottonseed meal, and linseed meal, which must be purchased.

**481. Rations for cows.** The following rations contain enough nutrients for a cow weighing 1000 pounds and producing 25 pounds of 4-per-cent milk daily. Cowpea hay can be replaced by alfalfa, clover, or soy-bean hay. Corn can be replaced by barley. Linseed meal can be replaced by cottonseed meal or gluten meal. Silage is considered a roughage and, when added to any of the rations, 3 pounds of silage is equivalent to 1 pound of hay in supplying bulk to the ration.

#### TYPES OF BALANCED RATIONS

	POUNDS		POUNDS
(1)		(4)	
Alfalfa . . . . .	12	Alfalfa . . . . .	10
Silage . . . . .	35	Silage . . . . .	35
Corn chop . . . . .	4	Corn-and-cob meal . . . . .	3
Bran . . . . .	2	Cottonseed meal . . . . .	1
Linseed meal . . . . .	1		
		(5)	
(2)		Clover hay . . . . .	12
Timothy hay . . . . .	18	Corn stover . . . . .	5
Barley (ground) . . . . .	5	Corn chop . . . . .	5
Linseed meal . . . . .	3	Linseed meal . . . . .	2
		(6)	
(3)		Sorghum fodder . . . . .	15
Alfalfa hay . . . . .	12	Wheat bran . . . . .	5
Corn-and-cob meal . . . . .	5	Kafir . . . . .	5
Cottonseed meal . . . . .	3	Linseed meal . . . . .	2

TYPES OF BALANCED RATIONS (CONTINUED)

	POUNDS		POUNDS
	(7)		(10)
Prairie hay . . . . .	18	Clover hay . . . . .	16
Wheat bran . . . . .	5	Oat straw . . . . .	4
Wheat shorts . . . . .	5	Oats (ground) . . . . .	3
		Barley (ground) . . . . .	4
			(11)
	(8)	Clover hay . . . . .	8
Cowpea hay . . . . .	18	Timothy hay . . . . .	8
Corn chop . . . . .	5	Sugar beets . . . . .	20
Cottonseed meal . . . . .	2	Corn chop . . . . .	4
		Oats (ground) . . . . .	3
			(12)
	(9)	Alfalfa hay . . . . .	10
Prairie hay . . . . .	18	Dried beet pulp . . . . .	5
Oats (ground) . . . . .	5	Corn chop . . . . .	4
Linseed meal . . . . .	2	Gluten feed . . . . .	1

**482. Raising the calf on skim milk.** When the calf is raised by hand the feeding should begin when it is only two or three days old. The longer the calf is allowed to run with its mother, the more difficult it will be to teach it to drink.

For the first two or three weeks, the calf should be fed several times daily on whole milk fresh from its mother. The amount to feed will vary from 8 to 12 pounds or from 1 to 1½ gallons a day. The change from whole milk to skim milk should be gradual and will require about a week's time. By the time the calf is four months old, it should be receiving about 2 gallons of skim milk a day. The milk should be fresh and should be fed at a temperature of from 90 to 95 degrees. The pails used in feeding the calf must be kept clean.

The grain ration for the calf on skim milk must be of such composition as to replace at least part of the butter fat taken from the milk. Corn will replace the fat in the milk fairly well. At first the corn should be ground, but later shelled corn may be used. The grain should always be fed dry, and never mixed

with the milk, because corn and other starchy foods should be thoroughly masticated and mixed with the saliva of the mouth to be well digested. No more grain should be fed at each meal than the calf will eat promptly and with a relish. Feed all the hay that the calf will eat at all times. When the calf is very young, timothy or prairie hay is better than alfalfa, clover, or cowpea hay, but later the legumes may be profitably fed. During the pasturing season, good grass is highly important.



FIG. 183. Homemade stanchions for feeding-calves

A clean, sunny stall or pen must be provided for the young calf (Fig. 183). Calves that are not separated, by tying or in stalls, at feeding time annoy one another by sucking their ears, and during the cold weather the ears are often frozen after they are wet in this manner.

**483. The dairy barn.** A cow will not do her best unless she is comfortable. The barn does not need to be expensive to be comfortable. It must provide a comfortable tie, a substantial floor that can be kept clean, plenty of fresh air and sunlight, and it should be warm enough for comfort in severe weather. In agreeable weather the cows should not be kept in the barn.



There must be plenty of windows to admit fresh air and sunlight. A dark barn affords an ideal place for the growth of bacteria. Sunlight is the greatest enemy of bacteria. A barn may be ventilated by dropping the windows in from the top.

The stalls should be adjusted to the size of the cows (Fig. 184). For Holsteins, or other large cows, the stalls should be at least  $3\frac{1}{2}$  feet wide and 5 feet long, measured from the stanchion to the manure gutter. For cows of the size of the Jersey, the stall should be 3 feet wide and  $4\frac{1}{2}$  feet long. It is advisable to make the platform wider at one end than at the other

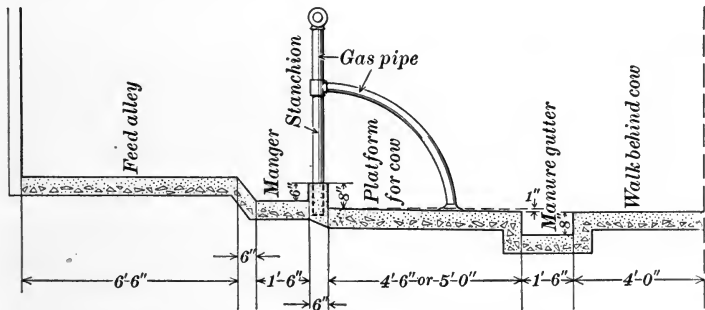

FIG. 184. Cross-section diagram of a dairy barn

other so that the largest cows may be accommodated at the wider end and the smaller cows at the narrow end. When the platform is accurately adjusted to the size of the cow, it is much easier to keep the cows clean. The manger should be at least  $2\frac{1}{2}$  feet wide and the manure gutter at least 16 inches wide and from 6 to 10 inches deep.

The floor of a barn may be made from almost any building material, but a cement floor will give more general satisfaction than any other, because the cement floor is durable and easier to keep clean. In colder climates a wooden platform can be built over the cement floor during the cold weather and thus protect the cows from the cold.

**QUESTIONS AND PROBLEMS**

1. How may a farm used for dairy purposes gain constantly in fertility?
2. Why is a good dairy cow said to be adapted to high-priced lands?
3. What are the characteristics of the leading dairy breeds of cattle?
4. Name the breeds in order of the richness of their milk. In the order of the quantity of milk given.
5. What are the two methods that may be used in the selection of a cow for profitable milk production? Which is the better method?
6. How would you proceed to keep a record of the individual cows in a herd?
7. State how one can make improvement in the productive capacity of the herd.
8. Describe the appearance of a high-producing cow.
9. What are the indications of good quality in a cow?
10. What are the indications of a good feeder?
11. What are the indications of a good heart and a good lung capacity?
12. Describe the udder and milk veins of a high-producing cow.
13. What are the important matters to consider in the selection of the herd sire.
14. What green crops may be used to supplement short pastures? How may succulence be added to the winter ration?
15. How can one tell when a cow is not getting enough feed? when she is getting too much feed?
16. Why should the cow have all the roughage she will eat?
17. How may we know how much grain to feed a cow?
18. Describe the best methods of handling and feeding calves which are to be raised on skim milk.
19. What are the principal considerations in building a barn for dairy cows?

**EXERCISES**

1. Make a drawing to scale, showing the floor plan of what you regard as a good dairy barn in which at least ten cows are to be kept.
2. Feed a cow a balanced ration for two weeks, then change to some such ration as corn and timothy hay or corn stover. Weigh and test the milk produced during each period. Compute the cost of feed and the value of the milk and butter produced in each period.

3. Score a number of dairy cows, then weigh and test the milk produced by each, and compare your judgment and that of the owner of the cows with the record of performance.

4. Visit dairy farms in your community. Make a record of the milk and butter fat produced by each cow, how much the herd is fed, and prepare a report showing whether any cows should be disposed of and why, whether the system of feeding should be changed, and whether the barn or yards can be improved.

#### REFERENCES

- CRAIG, JOHN A. Judging Live Stock. Kenyon Printing Company.  
ECKLES, C. H. Dairy and Milk Production. The Macmillan Company.  
LANE, C. B. Business of Dairying. Orange Judd Company.  
MICHELS, JOHN. Dairy Farming. Published by the author, Milwaukee, Wis.  
KING, F. H. Physics of Agriculture. Mrs. F. H. King, Madison, Wis.  
PLUMB, C. S. Types and Breeds of Farm Animals. Ginn and Company.  
Barns and Buildings, *Breeders Gazette*. Saunders Publishing Company.  
Literature concerning the various breeds may be obtained by addressing the following:
- American Jersey Cattle Club, 324 W. 23d St., New York.
  - Ayrshire Breeders' Association, Brandon, Vt.
  - Brown Swiss Breeders' Association, Middleburgh, N.Y.
  - Dutch Belted Breeders' Association, Easton, Pa.
  - Guernsey Breeders' Association, Peterboro, N.H.
  - Holstein-Friesian Association, Brattleboro, Vt.

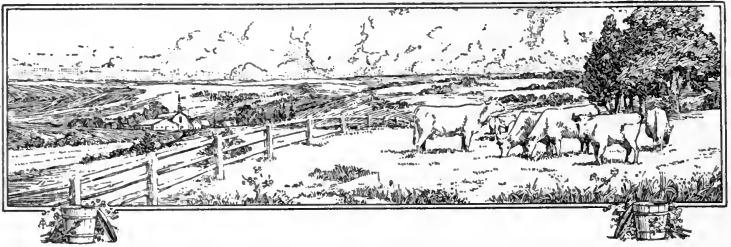

## CHAPTER XXXI

### DAIRY PRODUCTS

Surely the churning of milk bringeth forth butter.— THE BIBLE

**484. Recent progress.** In dairy regions each person consumes, on an average, a pint of milk a day. Outside of the dairy regions, only about half this amount, on the average, is consumed by each person. Long ago it was discovered how to make cheese and butter from milk, and the same principles were used then as now. Perhaps more progress has been made within the last fifty years, however, in improving the dairy cow and in the sanitary and economical handling of dairy products than in all time before. Increased production has been accomplished by modern methods of breeding, feeding, and testing the cows. The processes of dairy manufacturing have been profoundly influenced by the invention of the centrifugal separator, the discovery of the Babcock test (Fig. 185), and the development of methods of cold storage, of making condensed milk, and of cheese making.

**485. What milk contains.** Secretion of milk takes place in the milk glands or udders of animals which suckle their young. In the process of secretion the composition of the materials taken from the blood is changed by some unknown process to the substances found in milk. Milk is an opaque, yellowish-white fluid and possesses a sweetish taste. One hundred pounds of average milk contains 87.2 pounds of water, 3 pounds of casein, 3.9 pounds of butter fat, 4.75 pounds of sugar, .4 pounds of

albumen, and .75 pounds of ash. The butter fat is the most important and valuable constituent of milk.

**486. Butter fat.** Butter fat occurs in milk in small globules (Fig. 186) which vary greatly in size. Forty thousand of the smallest globules placed side by side would measure an inch, while twenty-five hundred of the largest when placed together would fill a like space. When these globules are matted together by being churned, butter is formed. Rich milk, such as that given by the Jersey cow, contains larger fat globules than does a lower-testing milk, such as is produced by the Holstein cow. Milk containing large globules will separate more completely and in less time, and will also churn more readily than milk containing small globules.

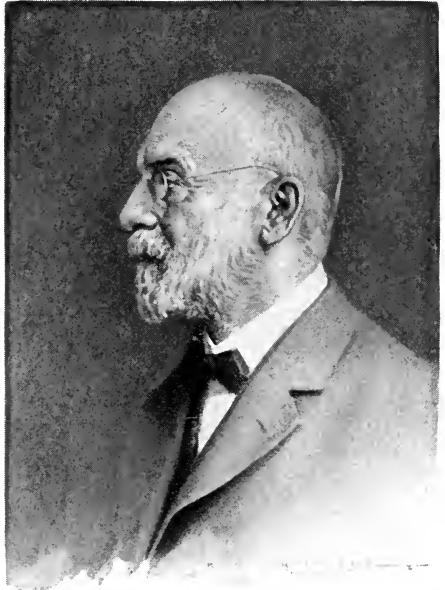

FIG. 185. The inventor of the Babcock milk tester

Professor S. M. Babcock of the University of Wisconsin, by means of the milk tester, has enabled many dairymen to discover and dispose of the "star boarder" cow. He has taught dairymen that "it is performance which counts"

One hundred pounds of the ordinary commercial butter contains about 1 pound of curd, 2 pounds of ash, 13 pounds of water, and 84 pounds of fat.

**487. Other components.** The casein and albumen make up the protein of milk which is used by the young animals to make blood, muscle, bone, skin, hair, hoof, and horn. The casein of milk forms a large part of cheese. The protein remains in the skim milk, which explains why skim milk is so valuable as a feed.

The milk sugar is a source of energy to the young animals, and when extracted from milk is of value in feeding infants and in diluting strong drugs. Nowhere else in nature is this kind of sugar formed, and it is the most readily digested form of sugar for infants. The ash of milk furnishes the ash of the

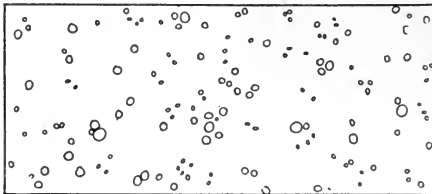
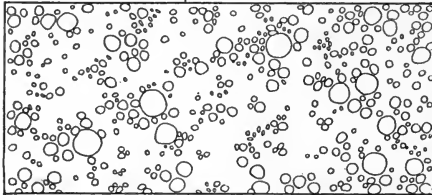
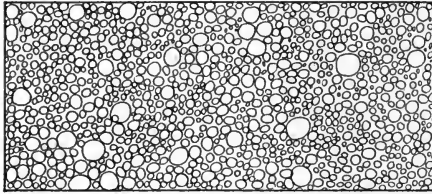

FIG. 186. Butter-fat globules

Reading from above downward, samples are shown of cream, milk, and skimmed milk under the same magnification. Proportionate numbers of fat globules are shown

(Fig. 187), and as soon as it is drawn it should be cooled and kept clean and cold. The lactic-acid bacteria grow best when the milk is kept at a temperature above 70 degrees; therefore the milk should be cooled and kept at 50 degrees or even a lower temperature, and should be cooled as soon as possible after milking.

body and is used principally in the growth of the skeleton.

#### 488. Bacteria in milk.

All milk drawn in the ordinary manner contains bacteria, most of which get into the milk after it is drawn. The most important are the lactic-acid bacteria, or those which cause milk to sour by changing the milk sugar into lactic acid. Other bacteria, some of which cause bad flavors and odors, also get into the milk. To check the souring process one must check the growth of the bacteria that get into the milk. To do this, the milk must be drawn in a covered pail

**489. Separating cream from milk ; the problem.** Butter-fat globules are lighter than the other constituents of the milk, and rise to the surface. The specific gravity<sup>1</sup> of the fat globules is .9, while that of skim milk is 1.034. Cream is merely milk in which the fat globules have been greatly concentrated. Ordinary whole milk contains about 5 per cent of butter fat, while cream may contain as much as 40 or 50 per cent.

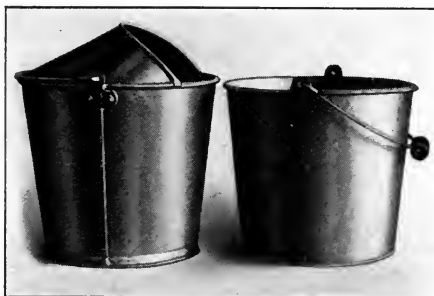

FIG. 187. Types of milk pails

The pail at the left is the better, because the hood helps to keep the dirt out of the milk

**490. Gravity systems.** For a long time cream was separated by gravity, a system which consisted of setting the milk in

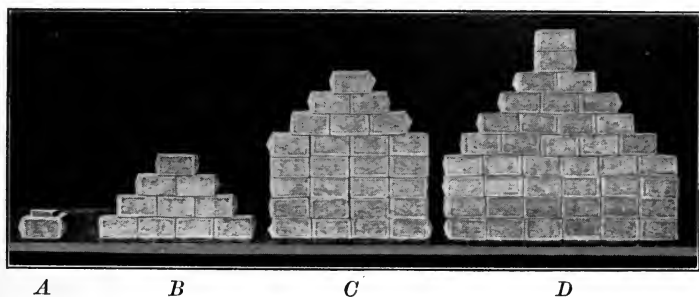

FIG. 188. How the separator saves butter fat

This illustration shows the relative loss of butter by different methods of skimming the milk from one cow in a year. *A*, centrifugal separator, 1.2 pounds loss ; *B*, deep setting, 10.1 pounds loss ; *C*, shallow pans, 26.2 pounds loss ; *D*, water dilution, 49.5 pounds loss. (Photograph from Purdue University)

shallow pans, allowing the fat globules to float to the surface, and then skimming them off. This was known as the shallow-pan

<sup>1</sup> The specific gravity refers to a comparison of the weight of a given quantity of fat globules or skim milk to the weight of a like quantity of water, both being at 0 degrees C.

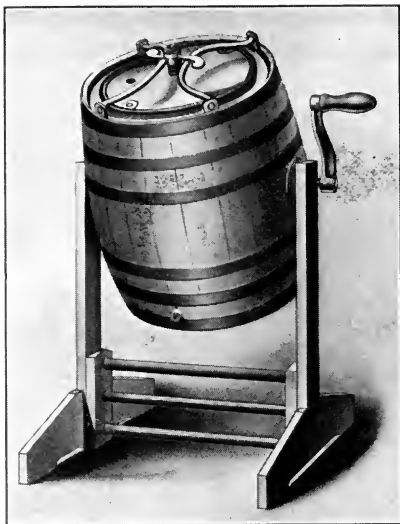

FIG. 189. The barrel churn

cools, the more complete is the separation.

**491. The Centrifugal System.** By this system less than a hundredth of the fat is left in the skim milk. The milk is poured through a bowl that is revolved at a high speed. The heavier particles of the milk are thrown to the outside of the bowl, while the lighter particles, the fat globules, are crowded toward the center. Near the outside of the bowl is an outlet for the removal of the skim milk, and near the center is a cream tube through which the fat globules, with more or less milk, are removed. Centrifugal separators differ in construction, but each kind has its advantages and each will do good work under proper conditions. Advantages of the centrifugal separator (Fig. 188) are: the cream can be separated immediately and

system and gave an imperfect separation, leaving from one fifth to over one third of the fat in the skim milk. Later it was discovered that a more complete separation could be insured in less time by setting the milk in deep, narrow cans. This was known as the deep-setting system. Under this system only about one fifteenth of the butter fat was lost, because the milk cools more quickly in the deepcans and the quicker it



FIG. 190. The old-fashioned dash churn



thoroughly; it can be made of any richness desired; and the skim milk may be fed to calves or pigs while it is fresh and warm.

**492. Making butter.** Cream is usually ripened, or soured, before it is churned. The ripening process consists of allowing cream to sour naturally or by adding sour milk or a commercial starter.<sup>1</sup> Sour, or ripened, cream churns more readily than sweet cream, and the butter keeps longer and has a better flavor.

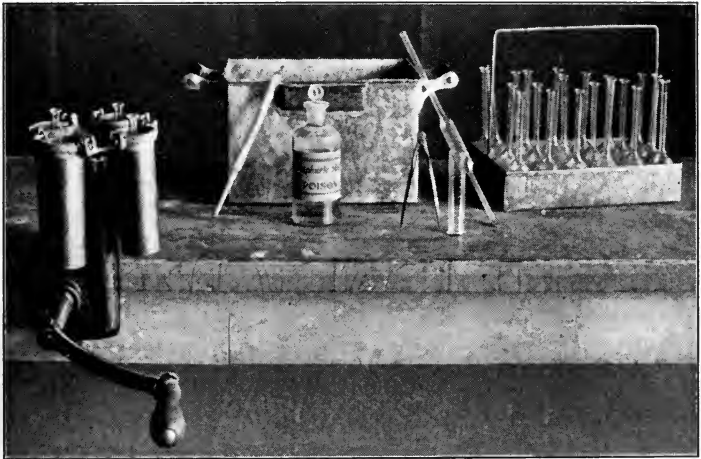

FIG. 191. A Babcock testing outfit

Butter when properly finished is composed of butter fat, water, salt, and a small amount of casein or curd.

Churning is a process of agitating the cream until the fat globules unite to form butter. The barrel churn (Fig. 189) is the best form of churn. The old dasher churn (Fig. 190) or other churns with inside fixtures are unsatisfactory because butter made with them has poor body or texture.

After the cream has been ripened, it should be brought to a temperature of 58 degrees in summer and 65 degrees in winter,

<sup>1</sup> A commercial starter is skim milk soured by adding a pure culture of lactic-acid bacteria.

and then poured into the churn. The cream is then agitated until the granules reach the size of wheat or corn kernels. This usually requires from thirty to forty-five minutes. The buttermilk is then drawn off, and water is added equal to the amount of buttermilk. The water should be from 2 to 5 degrees colder than the buttermilk. The butter is washed by revolving the churn several times; the water is then drawn off, and the butter is salted in the proportion of about one ounce of salt to each pound of butter. After salting, the butter should be worked until the salt is thoroughly dissolved and surplus water is removed. Butter that is not washed soon develops bad flavor and odor. Butter coloring is often added to cream to color the butter. The coloring used is a harmless vegetable product and does not color the buttermilk.

**493. Babcock test.** The Babcock test is a simple method of determining the per cent of fat in milk and milk products. By the use of the Babcock tester (Fig. 191) one can determine the richness of milk given by each cow in a herd. The test affords a method by which milk and cream are bought and sold on the basis of the butter fat they contain. Few inventions have done more to improve an industry than the Babcock test has done to improve the dairy industry.

#### QUESTIONS AND PROBLEMS

1. How much butter fat is produced by a cow which gives 10,000 pounds of average milk in a year? How much sugar? How much casein? How much albumen? How much ash?
2. Is a quart of fresh milk heavier or lighter than a quart of pure water, the two being at the same temperatures? What bearing has this fact upon the problem of why cream rises upon milk?
3. What is the difference between butter and butter fat?
4. Why is the barrel churn superior to the dasher churn?
5. Describe the whole process of churning.
6. Secure from a farmer or from a cream-purchasing firm a statement of the amount of cream sold by one farmer in your locality in one year. Find how many cows he used, and determine his income from this source. If possible, get records from several kinds of cows and compare the income.

## EXERCISES

**1. The Babcock test.**<sup>1</sup> The apparatus consists of a 17.6-cubic-centimeter acid-measure pipette, test bottles, dividers, water bath, centrifuge, and sulphuric acid with a specific gravity of 1.83 to 1.84.

Full directions for the use of the Babcock testing outfit are furnished by the manufacturers or may be secured from the state agricultural college. Samples of milk should be secured, and the whole amount produced by each cow being tested should be carefully weighed on three successive days. The butter fat in the milk should be determined by use of the Babcock tester according to the directions furnished. Compute the amount of butter fat produced during the month by each cow tested. By adding one fifth to the amount of butter fat, the amount of butter produced is determined.

**2. Methods of milking.** Obtain two pails — one with open top, the other with a partially closed top. Milk one half the milk from the cow into each pail. Pour a sample of the milk from each into two bottles and note which one keeps sweet longer.

**3. Methods of keeping milk.** Take two samples of milk fresh from the cow, cool one immediately to 50 degrees or lower (do not cool the second sample), place both samples in a fairly cool place (65 degrees F.), and note how long it takes each sample to sour.

**4. Methods of creaming.** Thoroughly mix a can of warm milk (90 degrees F.). Pour one fourth of it into a shallow pan, another fourth into a deep can, and another fourth into a second deep can. To the second deep can add as much water at a temperature of 50 degrees as there is milk. Set the pan and the two cans in cold water, and note the time required for the butter-fat globules to rise and form cream. Test the skim milk and the cream in each case and compare results.

**5. Richness of milk on creaming.** Get a sample of milk from a rich-testing cow and also a sample from a low-testing cow. Bring both samples to 90 degrees F. and run them through the centrifugal separator. Test the cream and skim milk from both samples and compare the results.

**6. How rapidly to turn the separator.** Divide a thoroughly mixed can of milk into three equal parts. Run one part through the

<sup>1</sup> Standard Babcock milk testers are now sold by many dealers and may be secured by a local merchant.

separator, turning the separator the speed required by the directions. Separate another part, running the separator at half speed and the remainder at three-fourths speed. Test the samples of the cream and skim milk of each run and note results.

#### REFERENCES

- ROSE, LAURA. Farm Dairying. A. C. McClurg and Company.
- MCKAY, G. L., and LARSON, CHRISTIAN. Principles and Practises of Butter-Making. John Wiley & Sons.
- WING, H. H. Milk and its Products. The Macmillan Company.
- Buttermaking, *Farmers' Bulletin 541*, United States Department of Agriculture.
- Use of Milk as Food, *Farmers' Bulletin 363*, United States Department of Agriculture.
- Bacteria in Milk, *Farmers' Bulletin 490*, United States Department of Agriculture.
- Production of Clean Milk, *Farmers' Bulletin 602*, United States Department of Agriculture.

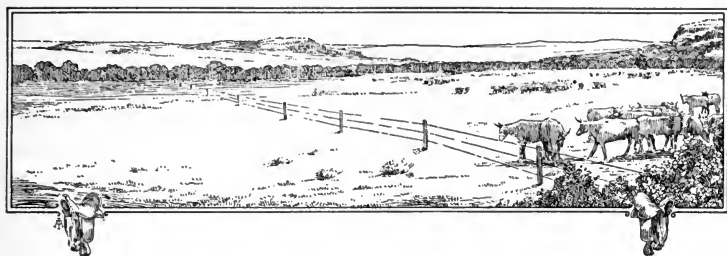

## CHAPTER XXXII

### BEEF CATTLE

That part of husbandry by the exercise of which one may quickly become rich is the grazing of cattle well. That part by the exercise of which one may have a tolerably good income is grazing cattle indifferently. — CATO

**494. Beef production.** The value of beef cattle in the United States exceeds the value of all other farm stock combined. Large areas of cheap grazing lands have been the principal basis of the beef-cattle industry. More than two thirds of the beef cattle in the United States are west of the Mississippi River.

The Western pastures, however, are being rapidly converted into farms. Not since the country was first settled has it contained so few beef cattle in proportion to population as now, and the need of cattle to maintain the fertility of farm lands is greater than ever. If we are to continue to produce as much beef as we eat, the beef industry will have to be extended on the general farms throughout the eastern half of the United States. There is no other farm animal which can use so large an amount of coarse feed, which can thrive in so wide a range of conditions of climate and attention, or which is so nearly free from disease and misfortune as the beef animal.

All our improved races of beef cattle originated in Great Britain, and have descended from two types of large cattle brought into that country during the Anglo-Saxon invasion. The principal breeds of beef cattle are the Shorthorn, the Hereford (Fig. 192), the Aberdeen Angus, and the Galloway.

**495. The Shorthorn.** The Shorthorn breed originated in northeast England along the river Tees, whose valley has long been noted for its excellent grazing. The development of the modern Shorthorn breed (Fig. 193) began about 1780, when two brothers, Charles and Robert Collings, of England, commenced the careful selection and mating of breeding-cattle on their farms. Shorthorns were first brought to the United States in 1783 by Gough of Maryland and Miller of Virginia.

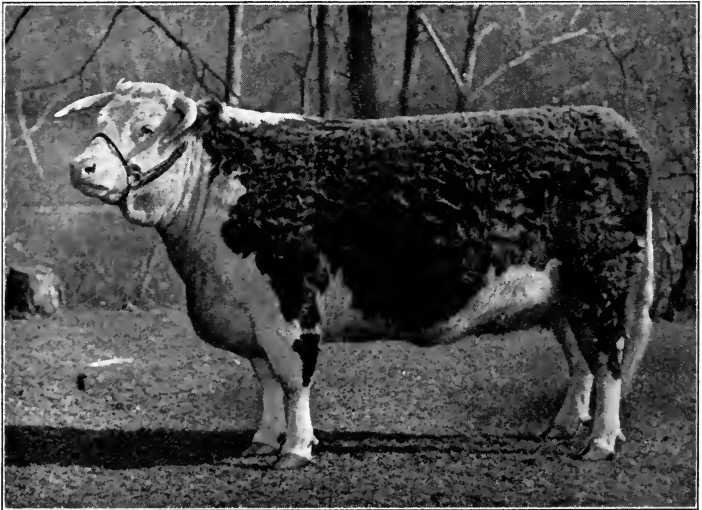

FIG. 192. A typical Hereford cow

The Shorthorns are the heaviest of the beef breeds. Mature bulls weigh about twenty-three hundred pounds, and mature cows weigh about five hundred pounds less. These cattle have a fine coat of medium-length hair, which may be red, white, roan, or spotted. They have a small, attractive horn from which they receive their name, and are noted for the strong development of their hind quarters. They are a trifle prominent in the shoulder and too long in the leg. Shorthorn cows are better milkers than are the cows of other beef breeds.

**496. The Hereford.** The Hereford breed takes its name from the county of its origin, Herefordshire, in southwest England. Long before modern methods of breeding had been employed, the cattle of Herefordshire had attained a high individuality and excellence. For generations the cattle of this district had been raised with special attention to size, strength, and docility and to fitness for the yoke. The first great improvers of this breed were the members of the Tompkins family, four generations of which were breeders of the early Hereford cattle.

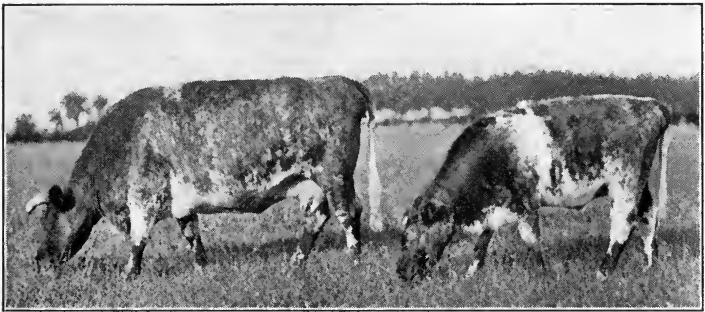

FIG. 193. Shorthorn cow and calf

Hereford cattle (Fig. 192) were first imported into the United States in 1817 by Henry Clay of Kentucky. The first importation of much consequence, however, was made in 1840 by W. H. Sotham of Albany, New York. For the next thirty years the Hereford breed gained adherents in the United States very slowly. About the year 1875 the ability of the breed to thrive under the conditions of the Western ranges began to be appreciated. From that time the popularity of the Herefords increased rapidly, especially west of the Mississippi River.

In weight the Herefords stand next to the Shorthorns and are noted for their wide-sprung ribs and full heart girth. They are somewhat lacking in the development of the hind quarters, but they are a thick-fleshed, early-maturing, and quick-feeding type. In milk production they are below the average.

**497. Aberdeen Angus.** The native home of the Aberdeen Angus breed is in the mountain region of northeast Scotland. Some progressive Scotchmen, learning of the success of the Collings brothers and others with the Shorthorn cattle in the country south of them, determined to improve their own native cattle, which then varied greatly in color and type. Hugh Watson



FIG. 194. Aberdeen Angus cow

of Forfarshire, in about the year 1808, was the first to undertake the improvement of these cattle. Aberdeen Angus (Fig. 194) was the last of the improved beef breeds to be introduced into the United States. George Grant of Victoria, Kansas, made the first importation into America in 1873. Since that time their adaptability to corn-belt conditions and popularity with the butcher have made them favorites with many cattle feeders.

The Aberdeen Angus is black in color, with a short, smooth coat, and is hornless. In conformation they are more cylindrical



than the other beef breeds; the top and bottom lines are straight and parallel. They are the smoothest and most evenly fleshed of the beef breeds. They are not as heavy as either the Shorthorn or Hereford. Prime steers of this breed meet the butcher's ideal more nearly than do steers of other breeds.

**498. The Galloways.** The original home of the Galloway is in that part of southwest Scotland popularly known as the kingdom of Galloway (Fig. 195). From time immemorial there have

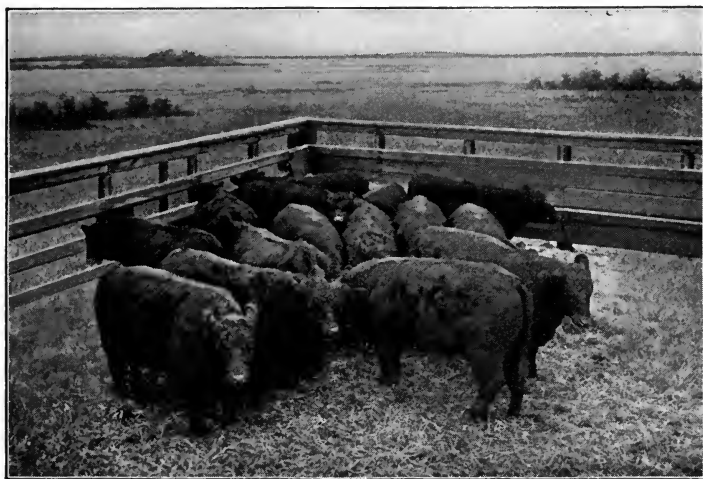

FIG. 195. A group of yearling Galloway steers

been hornless cattle similar to the present Galloway breed in this part of Scotland. But little attention was given to their breeding or improvement until the latter part of the eighteenth century. The origin of this breed cannot be said to be the result of any one man's work, but rather the result secured by the breeders of this district as a whole.

It is uncertain when the first Galloways were brought into the United States. It is said that there were Galloways in Pennsylvania as early as 1840. The first important importation was brought to Michigan in 1870.

Although not so compact or cylindrical in form as the Angus, the Galloways correspond more closely to that type than to the Shorthorn type. They are hornless and have a rounding, shaggy poll. They have thick, heavy hides and are somewhat inclined to be flat ribbed. The breed is characterized by a long, wavy, brownish-black coat with a thick furry undercoat which makes this breed peculiarly adapted to withstand the rigors of winter.

**499. Standpoints from which beef cattle are judged.** There are three standpoints from which beef cattle may be judged — that of the breeder, the feeder, and the butcher. Each of these men represents a separate and distinct part in our system of meat production and each places upon the animal certain requirements which are less keenly appreciated by the others. Any system of judging which does not consider all of these standpoints is incomplete. Since the ultimate purpose of beef-type animals is to serve as food and since the requirements of the butcher most nearly reflect those of the consumer, it is well to study the animal from this standpoint first.

**500. The type the butcher demands.** The butcher demands an animal that will dress a large per cent of salable meat, all of which is of good quality, but which has a large proportion of the high-priced cuts. In order to dress out a large per cent of salable meat, the animal must be compact and stockily built, low set, broad, and deep-bodied, with small extremities. In the most approved type the back is broad and practically level from the top of the shoulder to the tail head, while the underline is low and parallels the top line. Any tendency toward paunchiness, ranginess, or coarseness of bone subtracts from the proportion of salable meat and is severely condemned by the butcher.

**501. Must be well finished.** The percentage of salable meat and also the quality of the meat are markedly influenced by the condition or fatness of the animal. Thin animals carry a much larger proportion of waste than do fat animals. Very little of the increased weight acquired by fattening is in the offal and a large per cent of it is found in the high-priced cuts. This may be ascertained by comparing the thickness of fat on the various

parts of a well-finished carcass. It will be found that the largest deposits of fat are in the higher-priced cuts, showing that during the fattening process these cuts gain in weight more rapidly than the rest of the animal.

**502. Must be of good quality.** Quality is a term used to designate the character of the bone, skin, hair, and of the meat itself, and is closely associated with the impression one gets from handling the animal. The term *good quality* denotes a soft coat of fine hair, a pliable, elastic skin of medium thickness, clean, dense bone, and a firm, even covering of flesh. Coarse, rough coats and thick hides are usually associated with coarse bone and rough joints and are an indication of lack of quality. The pliability and mellowness of the hide can be determined by taking between the thumb and forefinger a fold of the skin lying over the ribs.

**503. The type the breeder and feeder desire.** The breeder and feeder should consider form and quality even more carefully than does the butcher, for they mean more to him. Cattle of good beef type are more easily fattened than poorly formed animals. The blocky form with small extremities and good quality, so important from the butcher's standpoint, is also an indication of early maturity, a characteristic of much importance to the breeder and feeder. An extreme refinement of skin, bone, and hair, which to the butcher indicates minimum waste in these parts, indicates to the breeder or feeder a lack of hardness or ruggedness. Likewise the desire of the butcher to reduce the waste of the beef animal, if carried too far, would be objectionable to the feeder because of reducing the digestive capacity to a point where the animal could not consume enough feed to be profitable. It is evident, then, that a good judge must combine the points of excellence from the standpoint of the butcher, the feeder, and the breeder, and must establish a standard which will be equally fair to all three.

**504. How to judge beef cattle—general view.** The judge should first take a general view of the animal from sufficient distance to enable him to study its proportions and general

symmetry. This general view should enable him to form at once an opinion regarding size, weight, and general conformation, condition, and quality. A detailed examination should then be made.

**505. The head.** The head should be free from either coarseness or delicacy. It should be broad and short, with a broad,

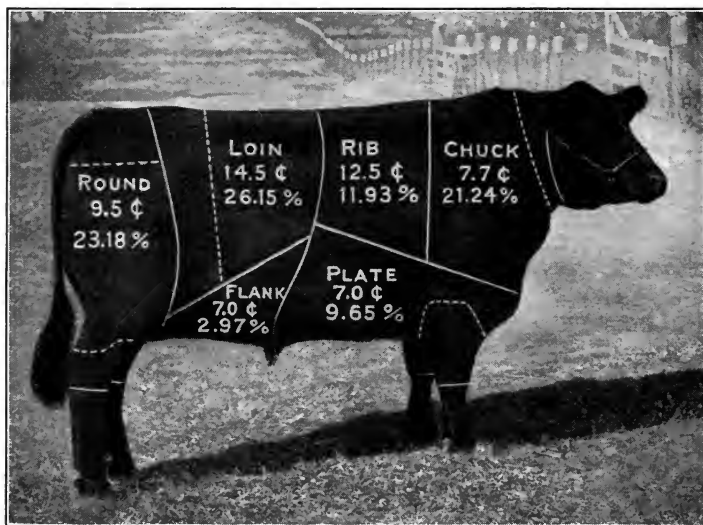

FIG. 196. The principal cuts of beef

The solid lines show where the cuts would be made for the wholesale trade, and the dotted lines where additional cuts would be made for the retail trade. The prices per pound given vary from time to time, but their relation to one another is fairly constant.

The percentage figures give the proportional amount of meat of each kind

full forehead and clean-cut face. The eye should be large, clear, and placid. The face from the eye to the muzzle should be short and refined. A slightly dished face is preferable, but a straight profile is not objectionable. The muzzle should be broad, with large mouth and moderately thin lips. The nostrils should be large. The lower jaw should be strong and heavily muscled, making a full cheek. An ear of medium size and fine texture is considered an indication of quality. These points of

excellence in the head, while of little value in themselves, are given much weight by the judge because they are a very reliable index to the general conformation and quality of the animal.

**506. The neck.** Passing to the right of the animal, observe the length and depth of the neck. It should be short and full, blending smoothly into the shoulders, making a full shoulder vein. In bulls there should be a prominent crest, indicating masculinity. A slight crest is often noticed on fat steers and very fat cows. An excessive amount of pendulant skin under the throat, or dewlap as it is called, is objectionable and unsightly.

**507. The shoulder and forelegs.** The shoulder should be compact on top and blend smoothly with the heart girth on the sides. Shoulders which stand out from the body are nearly always poorly covered and give the animal the appearance of having a shallow girth. There should be considerable width through this region, giving large chest capacity and a wide breast, which should be full in front of the chest and symmetrically rounded off below the junction with the forelegs by a neat, full brisket with little dewlap. The forelegs should be short, with fine, smooth shank covered with fine hair and skin.

**508. The chest.** The heart girth should be full and even with the shoulders. Any depression behind the shoulders means either coarse shoulders or poor spring of forerib and lack of width through the chest. The narrow-chested steer is usually an unprofitable feeder.

**509. The loin.** Reference to the accompanying diagrams (Figs. 196, 197, and 198) shows that the high-priced meat is found on the back and loin. In the live animal the loin is usually considered as that part of the back between the hooks and the last rib. It should be broad and heavily muscled. The thickness of the loin may be determined by pressing the palm of the hand against the side of the loin, with the fingers above and the thumb below. This observation should be made on the right side so as to avoid an effect of bloating which often modifies the contour of the left side. The covering should be thick, smooth, and firm, yet yielding slightly to the touch.

**510. The ribs.** The second-highest-priced cut is the prime of rib, which is located just in front of the loin and includes the upper part of seven ribs. In order to give breadth to the back, the animal must have a well-sprung rib. Considerable length of rib is desired in order to give depth of body, which is essential to a good feeder. A good development of muscle in this region is especially important from the butcher's standpoint.

**511. The hips.** The distance between the hips should be in proportion to the other parts of the animal. They are often too prominent and poorly covered.

**512. The rump.** The width at the hips should be carried well back to the end of the rump, which should be long and level. A pinched, drooping rump is a bad defect. On the other hand, an extremely high tail head is undesirable, not only because it is unsightly itself but because it also gives the loin the appearance of being poorly developed. A thick, firm covering about the tail head is considered by most cattle buyers to be an indication of good finish throughout. The pin bones should be far apart and smoothly covered.

**513. The twist.** The thighs should carry out the general width of the body and be deep and long. Common and inferior animals are usually easily recognized by the poor development of hind quarters, high, split twist, and lack of depth in flank. Animals of good beef conformation have a deep, plump twist and low, full flank. The fullness of the flank when the animal is standing naturally is a good index to the fatness of the steer.

**514. The legs.** The hind legs should be short and straight and placed well apart. Crooked hind legs and cycle hocks are very often found in cattle and are very undesirable, but not especially detrimental to the animal from the butcher standpoint, unless their conformation is so faulty as to weaken them.

**515. The score card.** To facilitate the study of the different points already mentioned and to aid in establishing a correct ideal, instructors in stock judging have prepared a score card giving numerical values to the various points to be considered. A score card for beef cattle is given in Appendix G.

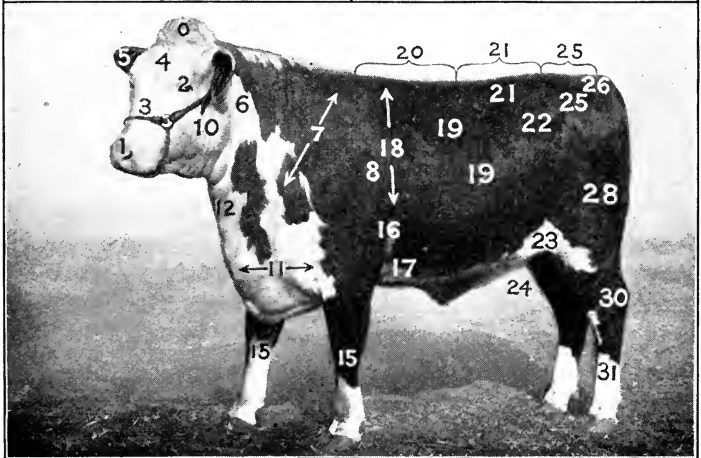
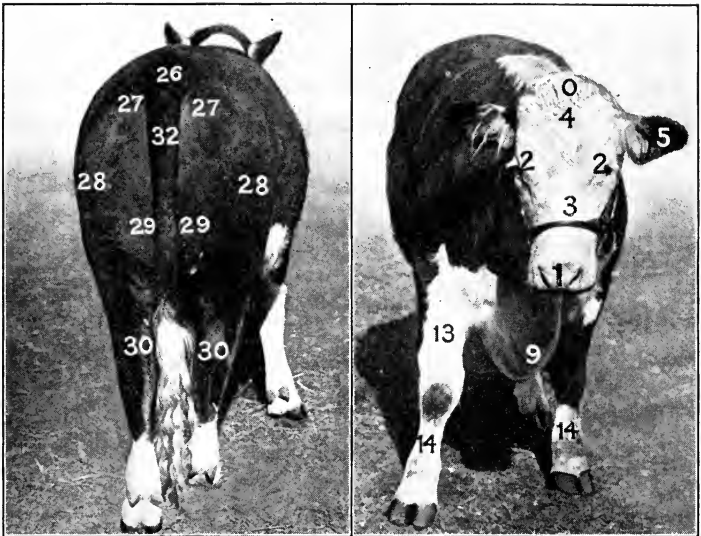

FIGS. 197 and 198. The points of a beef animal

0, poll; 1, muzzle; 2, eyes; 3, face; 4, forehead; 5, ears; 6, neck; 7, shoulder vein; 8, shoulders; 9, brisket; 10, jaw; 11, breast; 12, dewlap, or heavy skin of neck; 13, arm; 14, shin; 15, legs; 16, chest; 17, foreflank; 18, crops; 19, ribs; 20, back; 21, loin; 22, hips, or hooks; 23, hindflanks; 24, purse, or cod; 25, rump; 26, tail-head; 27, pin bones; 28, thigh; 29, twist; 30, hocks; 31, shanks; 32, tail

**516. Fattening cattle a specialized industry.** Fattening cattle has become a highly specialized industry. The man who raises cattle seldom fattens and markets them. Like any other highly specialized industry, the method used in fattening cattle has become well established and exact. Yet the finishing and marketing of cattle is one of the most complicated operations in agriculture, principally because of the large element of speculation due to the fluctuation in the value of feeds and of the finished product.

**517. Corn is the basic ration in cattle feeding.** In the early part of the feeding period with aged cattle, especially if they are thin, no special preparation of the grain will be required. As the feeding period advances, and as the cattle progress toward a finished condition, their appetites become more discriminating and they require more palatable and convenient food. Hence, shelled or crushed or ground corn is frequently fed in the finishing period where whole-ear corn or even shock corn was used at the beginning. With young cattle it is important to cater especially to their appetites so that they may overcome the handicap that their tendency to grow imposes. The corn should be shelled for them. In summer feeding it is more important to prepare the grain well.

**518. The amount of roughage to feed.** In the early part of the feeding period roughage of good quality, such as legume hay and silage, should be fed liberally. It is advisable gradually to limit the allowance of roughage in the last thirty or forty days of the feeding period or to offer roughage of a less palatable nature so that the cattle may not be encouraged to neglect their grain.

**519. Balancing the ration.** A ration consisting of corn and corn stover, timothy hay, or corn silage will not be satisfactory because it does not contain the proper proportion of protein.

A fairly good balance can be maintained between protein and carbohydrates by use of a leguminous hay as the only roughage; but usually an additional source of protein, as cottonseed meal or linseed-oil meal, especially during the latter stages of the feeding period, should be added. Usually two and one-half to three pounds of either of these protein foods per thousand



pounds live weight will be sufficient to balance the fattening ration even where no leguminous roughages are used. These concentrates are also very effective when used with shelled corn for summer feeding on grass.

**520. Standard rations.** Some standard winter rations for stock cattle are given below :

FEED PER 1000 POUNDS (Live weight)		FEED PER 1000 POUNDS (Live weight)	
(1)		(6)	
Corn silage . . . . .	20 lb.	Corn or sorghum silage . . . . .	30 lb.
Clover hay . . . . .	8 lb.	Cottonseed meal or linseed meal . . . . .	1 lb.
Oat straw . . . . .	5 lb.	Oat straw . . . . .	10 lb.
(2)		(7)	
Corn silage . . . . .	15 lb.	Shocked corn . . . . .	10 lb.
Cottonseed meal . . . . .	$\frac{1}{2}$ lb.	Cowpea hay . . . . .	15 lb.
Clover hay . . . . .	5 lb.		
Oat straw . . . . .	10 lb.	(8)	
(3)		Shelled corn . . . . .	3 lb.
Corn silage . . . . .	40 lb.	Cowpea hay . . . . .	10 lb.
Cottonseed meal or linseed meal . . . . .	1 lb.	Oat straw . . . . .	5 lb.
(4)		(9)	
Corn silage . . . . .	15 lb.	Clover, cowpea, or alfalfa hay . . . . .	15 lb.
Alfalfa hay . . . . .	10 lb.	Oat straw . . . . .	8 lb.
Oat straw . . . . .	5 lb.	(10)	
(5)		Kafir or sorghum silage . . . . .	15 lb.
Corn stover . . . . .	20 lb.	Alfalfa hay . . . . .	10 lb.
Shelled corn . . . . .	$2\frac{1}{2}$ lb.	Oat straw . . . . .	5 lb.
Alfalfa hay . . . . .	8 lb.		

Winter rations for pure-bred herds kept in relatively high condition for the inspection by prospective buyers :

(1)		(2)	
Ground corn . . . . .	2 lb.	Corn-and-cob meal . . . . .	3 lb.
Ground oats . . . . .	2 lb.	Ground oats . . . . .	2 lb.
Linseed meal . . . . .	1 lb.	Bran . . . . .	1 lb.
Clover hay . . . . .	10 lb.	Linseed meal . . . . .	1 lb.
Oat straw . . . . .	constant supply	Corn silage . . . . .	25 lb.
		Clover hay . . . . .	5 lb.

## QUESTIONS AND PROBLEMS

1. What is the relation of the production of beef animals to soil fertility?
2. What are the general characteristics of the beef animal?
3. What are the areas of the greatest beef production at the present time?
4. What are the leading cattle markets of the United States?
5. In what important ways will the beef-producing industry of the future need to differ from that of the present and past?
6. What are the principal breeds of beef cattle?
7. Describe the history and characteristics of the Shorthorn; of the Hereford; of the Aberdeen Angus; of the Galloway.
8. From what standpoints should beef cattle be judged?
9. What types of beef animal does the butcher demand? How may this differ from the feeder's needs?
10. What is included under "quality" of the beef animal?
11. To what extent should the breeder and feeder consider form in the beef animal?
12. Study carefully the important points in judging beef cattle. Score a beef animal, following the score card given in Appendix G.
13. Why is fattening cattle so important an industry?
14. What rules should be followed in the preparation of feed for fattening cattle?

## REFERENCES

- GAY, C. W. Principles and Practices of Judging Live Stock. J. B. Lippincott Company.
- HARPER, M. W. Manual of Farm Animals. The Macmillan Company.
- HENRY, W. A. Feeds and Feeding, chap. xxi. Published by the author. Madison, Wis.
- MUMFORD, H. W. Beef Production. Published by the author. Urbana, Ill.
- PLUMB, C. S. Beginnings in Animal Husbandry. Ginn and Company.
- PLUMB, C. S. Types and Breeds of Farm Animals. Ginn and Company.
- Breeds of Beef Cattle, *Farmers' Bulletin 612*, United States Department of Agriculture.
- Live-Stock Judging for Beginners, *Circular 29*, Purdue Agricultural Experiment Station.



## CHAPTER XXXIII

### SWINE

**521. Introductory.** The modern hog was probably derived from the wild types of Europe and southern Asia. In the United States the hog ranks second in importance among the farm animals. The United States is the leading swine-producing country, having about two fifths of all the swine of the world. Years of selecting and breeding for two distinct purposes have given rise to two distinct types of hogs — the lard type and the bacon type. Each type comprises several distinct breeds.

**522. The lard hog.** The lard hog is an American product, and is essentially a corn-belt hog. The early settlers needed a hog which would produce meat and lard, both of which might be kept through the summer months. These products found a market wherever there was a demand for palatable food which would furnish an abundance of heat and energy. Later it was found that this same type of hog was the most suitable for marketing the large crops of corn that were produced. Thus the hog that would put on the most fat was the one most sought (Fig. 199). The need of the corn-belt farmer in later years has not been so much for a market for his corn as it has been for a means of converting his feed into pork and lard to feed the people of the cities.

Breeders and farmers had different ideals, and several distinct breeds of the same general type were originated. Each has its particular merits, as judged by the fancy of the breeder. The

lard hog is short-legged, thickset, and compact; large, thick hams and a thick, fat back are essential points in its make-up. Hogs of this type have a tendency to mature at an early age and to fatten easily. The most common breeds are the Poland China, the Duroc-Jersey, the Berkshire, and the Chester White.

**523. The Poland China.** This breed was developed in the Miami valley, in Ohio, between 1816 and 1845. It originated through the mingling of several breeds, and was later improved



FIG. 199. Fine specimens of aged Poland China sows

by selection. The Poland China (Fig. 199) approaches very closely to the ideal fat-hog type. The head is of medium length, the face straight, the jowl full and rounding, and the ears fine with the outer one third breaking over. The shoulders should be wide and smooth, and the back wide and slightly arching. The best specimens of the breed have wide, deep chests, deep sides of medium length, and fairly short legs with bones of good size, strength, and quality. The loin should be wide and smooth and the rump of medium length and slightly rounding. Deep, thick, full hams are characteristic of

the breed. The animal should stand well upon its feet, as broken-down pasterns are very objectionable. The usual type color is black, with white on the feet, the tip of the tail, and the face, but fancy points in color are not emphasized so much now as they were formerly. The desire for a larger Poland China hog has led to the development of the spotted or large-boned Poland China, and in some sections this hog has become a favorite. It is characterized by large, irregularly shaped, white spots in the black coat and by very large bone, and because of its size, vigor, and hardiness it is a hog of great promise.



FIG. 200. Duroc-Jerseys ready for market

**524. The Duroc-Jersey.** The Duroc-Jersey breed originated in New York and New Jersey and, like the Poland China, is the result of the mingling of several types or breeds. For years there were two types of red hogs, the Durocs of New York and the Jersey Reds of New Jersey. These two types were finally blended, and the breed that resulted was called the Duroc-Jersey (Fig. 200). This hog is much like the Poland China in general conformation. The face is slightly dished. The desirable color is a bright cherry red, but lighter or darker shades are permissible. Black spots are objectionable. The breed has long been noted for its fecundity and the motherly instinct of the sows.

**525. The Berkshire.** The Berkshire originated in the county of Berkshire, in south-central England. It is the oldest of the improved breeds of hogs, having been known as a breed since 1789. The first Berkshires introduced into America probably were imported about 1823. While the breed originated in England, the greater part of its improvement has been accomplished in America. The Berkshire (Fig. 201) is somewhat longer of body and not so wide as the Poland China. It is generally regarded as a bacon hog in England and Canada, although as used



FIG. 201. The Berkshire type

in the corn belt it is distinctly a lard hog. Quality and smoothness are Berkshire characteristics. The head and face of the Berkshire is of medium length, the face being deeply dished. The legs are fairly short. The back of the Berkshire should be fairly wide and level or slightly arching. The sides should be long and deep, and the hams

and shoulders deep and full. The Berkshire, like the Poland China, is black, with white on the feet, the tip of the tail, and the face.

**526. The Chester White.** The Chester White hog was first developed in Chester County, Pennsylvania. Later the Ohio Improved Chester Whites, commonly known as O. I. C., were developed. In form the Chester White (Fig. 202) is not greatly unlike the Poland China, but it is larger in every way. The head is of medium length and the face is straight. The ears point forward and break from one third to one half from the outer tip. The back is wide and slightly arching. The body shows good depth, the shoulders are full and smooth, and the legs are of

medium length and strong. This breed has been criticized for having weak pasterns, but breeders are now paying more attention to this point. Black or bluish spots on the skin are objectionable.

**527. The bacon hog.** The bacon hog, as compared with the lard hog, has a longer head, longer legs, smoother shoulders, lighter hams, and produces much less fat. A smooth back, long, deep, smooth sides, and smooth shoulders and hams are

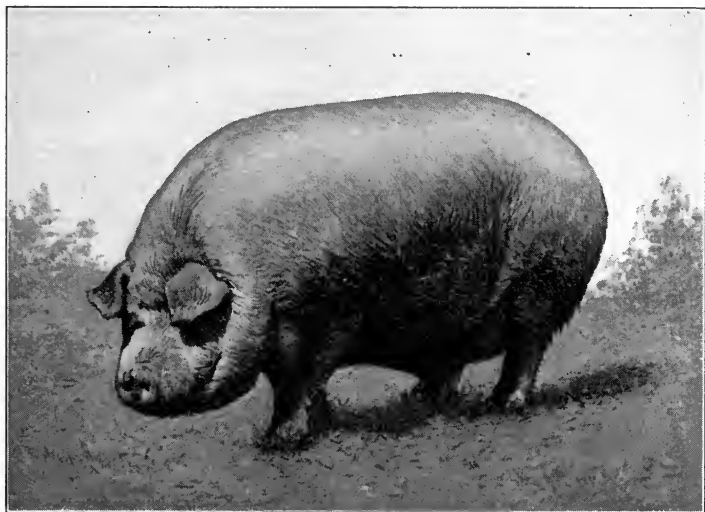

FIG. 202. The Chester White

This hog weighed 785 pounds when the picture was taken, at less than two years of age

essential characteristics of a good bacon hog. This hog does not require so much fat-producing feed as does the lard hog, consequently hogs of this type are grown in greatest numbers outside of the corn belt. The breeds raised in this country are the Large Yorkshire, the Tamworth, and the Hampshire.

**528. The Large Yorkshire.** The Large Yorkshire (Fig. 203) originated in the county of York, in eastern England. It is not known just when specimens of this breed were first brought into America, but it probably was previous to 1840. This is the

largest of the bacon breeds. The head is of medium length, and the face is dished. The ears are of medium size and droop slightly forward. The back is of medium width, and the body is long and deep. The shoulders and hams should be smooth, and the thighs should be fairly thick. This breed is always white, though bluish spots on the skin are sometimes noted.

**529. The Tamworth.** The Tamworth originated in central England, and probably was introduced into this country about 1882. The Tamworth is large and lean and has a long head,

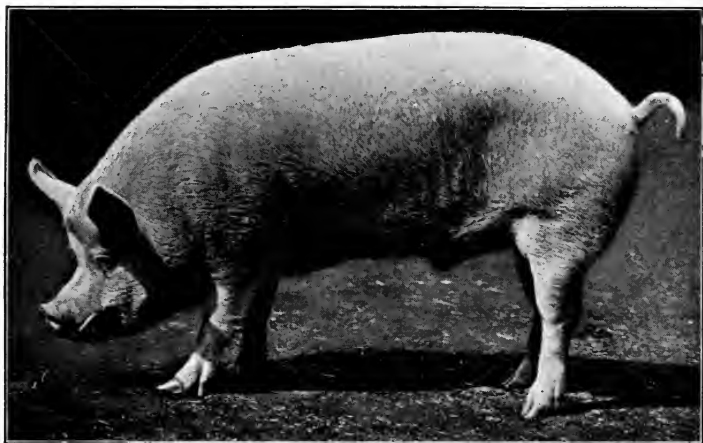

FIG. 203. The Yorkshire hog

Note the rangy appearance and long sides of the bacon type of hog

a long body, and long legs. The face is long and narrow and only slightly dished. The snout is long and straight. The sides should be long and deep, and the hams and shoulders should be thick and smooth. The color is red, and black spots are objectionable.

**530. The Hampshire.** The Hampshire hog (Fig. 204), sometimes called the "Thin Rind" hog, probably originated in Kentucky. This breed is of medium size, and when grown in the corn belt it takes on more fat than the other bacon breeds. On account of this tendency it is classed as a lard hog in the



corn belt. The head and face are straight; the ears are erect or droop slightly forward. The body is of medium length and depth, and the bone shows strength and quality. Hogs of this breed are very prolific, and the young are excellent "rustlers," growing well on pasture feed. The striking characteristic of the breed is the color, which is black with a white belt running around the body just including the forelegs. This belt is the *list*,



FIG. 204. The Hampshire hog

This breed combines the lard and bacon types, and is known for its prolificness.  
(Photograph from Essig Brothers)

and the color is spoken of as *listed color*. Sometimes individuals of the breed are solid black, but solid colors are not popular.

**531. Management of the herd.** Exercise, sunshine, and good wholesome feed are essential to the proper development of hogs. Dry-lot feeding will not develop the constitution, strength, and vigor needed by breeding animals. Clover, alfalfa, and rape make the best pastures, as they supply the protein and ash needed in building muscle and bone. If such pastures are not available, or do not thrive in a particular locality, other forage crops and grasses can be used.

In addition to pastures some feed that is more concentrated should be used. Corn is the principal grain used in many sections, but barley, kafir, milo, and wheat, if not too high-priced, can be used where corn is not available. But corn and pasture do not supply all the food materials needed by the growing pig. There should also be a proper allowance of some feed rich in protein, such as skim milk, tankage, meat meal, wheat shorts, or middlings. The amount of grain given should be just enough to keep the young hogs thrifty and growing, but not enough to make them fat. Too much fat will cause them to be lazy, and they will not graze enough to make the cheapest gain nor to develop strong constitutions.

Breeding stock should not be fed too much corn, as it tends to produce too much fat, and the amount of protein-bearing feeds should be increased over that required for fattening hogs. The protein foodstuffs should consist mainly of bran or ground oats and shorts, with a small amount of oil meal or tankage. The sow should be fed alfalfa hay if it is available, as it will both improve and cheapen the ration. A ration consisting of 50 per cent corn, 25 per cent shorts, 18 per cent wheat bran, 4 per cent linseed meal, and 3 per cent tankage, with good pasture or alfalfa hay, will give splendid results.

**532. Feeding the young pig.** The pigs soon learn to eat, and as soon as they do, a separate pen or eating place should be provided. It is a good plan to give the pigs what feed they will eat readily twice a day. It is better to feed a little under their capacity than to feed more than they can consume. The mother should be fed so that she will produce a good flow of milk, as this is the best feed the young pigs can have. A mixture consisting of 62 per cent corn, 30 per cent shorts, and 8 per cent tankage, with alfalfa hay or a good pasture, makes an excellent ration for the growing pigs.

**533. Finishing the hogs for market.** Experiment-station results and farm practice have shown that between the ages of six and twelve months and between the weights of from one hundred and ninety to two hundred and fifty pounds is the most

profitable age and weight at which to market hogs. Since the hog does not mature until it is sixteen or more months old, it must put on fat while still making growth if marketed at this early age. The finishing period is therefore but a modification and continuation of the growing period.

Two general systems of fattening hogs are practiced. Under one system the hogs are confined to dry yards and fed until they are ready for market. Under the other system they are allowed the run of the pastures or fields, with forage and pasture crops. The first is essentially the method followed in winter, and the second is the method usually followed in summer. Corn alone will not produce satisfactory gains on hogs that are still making growth, and the best feeders no longer inclose and feed their hogs in dry lots on corn alone.

**534. Feed for fattening hogs.** Kafir, milo, and similar grains may be used instead of corn in western Kansas, Nebraska, Oklahoma, and regions with similar climatic conditions. These small hard grains should be either ground or soaked for best results. Where barley is a staple crop, it may be used successfully. The results of experiments show that from the standpoint of efficiency and rate of gain obtained, barley has a feeding value very little lower than corn. Rye has about the same feeding value as barley, and emmer ranks about 5 per cent lower than barley.

**535. How to balance the ration.** The leading regular or supplementary feeds to produce growth are tankage, meat meal, skim milk, buttermilk, shorts or wheat middlings, linseed meal, soy beans, Spanish peanuts, cowpeas, or cull beans and field peas. The leguminous hays, among which alfalfa takes the leading place, are also used to a considerable extent. It is better as a rule to use a combination of these feeds instead of any one alone, though the price, as well as the efficiency, is always to be considered. The results of a series of experiments conducted at the Kansas Experiment Station, to determine the relative feeding value of a number of such supplements, showed that a combination of corn, shorts, and tankage or meat meal

was the best of the rations tested, and corn alone gave poorer results than any of the others. Wheat middlings as a rule is slightly higher in feeding value than is shorts. When tankage or meat meal is fed, only the 60-per-cent grade should be bought. Linseed meal, on account of its lower protein content, is not

so valuable a feed for young hogs that are being fattened as tankage, but because of its laxative effect it is of equal value when fed in moderate amounts to brood sows.

Skim milk and butter-milk are among the most valuable supplements to corn, and should be fed in the proportion of about three pounds of milk to one pound of corn. Soy beans, peas, Spanish peanuts, and cull beans are rich in protein and in many instances can be harvested by the hogs. The value of alfalfa hay for growing and fattening hogs is

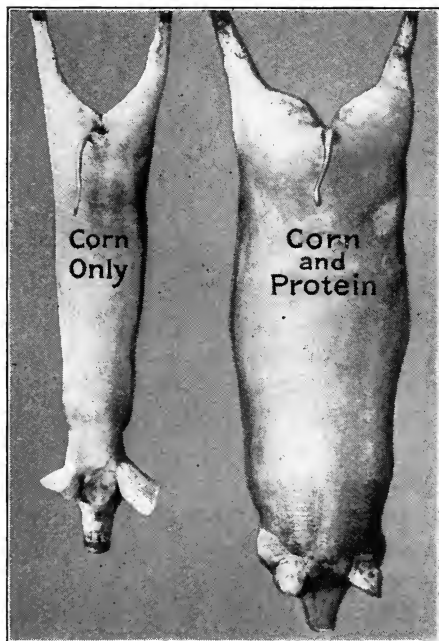

FIG. 205. Full brothers fed in different ways  
The small pig was fed corn alone; the large pig was fed corn and protein

well established by experiments (Fig. 205) and farm practice, and when suitable concentrated protein supplements are not available, it will pay to feed corn and hay instead of corn alone.

**536. The best hog pasturage.** Alfalfa makes the best hog pasture (Fig. 206). An acre of alfalfa will carry from ten to twenty hogs during the pasture season. When pasturing this crop it should be allowed to mature at least two hay crops during

a season. Red clover ranks next to alfalfa in point of efficiency. Alsike and Japan clover and the vetches can be pastured to good advantage. A mixture of blue grass and white clover is the permanent pasture in many states and makes a good hog pasture. Sweet clover is not without value if pastured before it gets coarse and woody.

When an emergency crop is needed to supplement the permanent pastures, Dwarf Essex rape is one of the best crops that can be employed. It thrives best on rich, moist soils and can be



FIG. 206. Pigs like alfalfa hay

seeded at any time from early spring to late summer. If not pastured off too closely, it will grow up two or three times during a season. Three or four pastures seeded at different times will furnish feed from early summer until late fall. Experiments have shown that rape pasture is almost equal to alfalfa pasture.

Mixtures of oats and rape, oats and field peas, and clover and rape have given good returns. Cowpeas and Spanish peanuts are good for fall use. Sweet sorghum can be pastured with profit, since it is a heavy yielder and can be grown on land that does not furnish enough moisture for rape.

**537. Sanitation and common diseases of hogs.** No other farm animal is so much abused by being kept in filthy quarters as is the hog, and yet the animal is cleanly in its habits when given

an opportunity to exercise its natural instincts. There are few ailments and diseases of swine that cannot be prevented if clean yards and houses and warm, dry beds are provided. By these means cholera, pneumonia, and thumps may in a large measure be prevented. An outbreak of cholera in the herd or in the vicinity justifies prompt treatment with anti-hog-cholera serum. The houses or sleeping quarters should be well ventilated, and arranged so that the drafts will not blow directly on the hogs. The beds should receive the sunshine and should not be wet, damp, or dusty. It is advisable to clean and re-bed the houses and remove all accumulations of manure and corncobs from the pens or yards once a week. The houses and yards around the eating places and sleeping quarters should be thoroughly disinfected with a strong solution of a standard dip or other disinfectant, and as soon as they are dry they should be sprinkled with air-slaked lime. The old-fashioned mud wallow should be eliminated and a cement pit that can be kept clean and sanitary should be provided for the hogs during hot weather. The sanitary wallows should be located conveniently near to the summer pastures. Crude oil or some standard dip may be used in these wallows to prevent disease infection and to keep the herd free from parasites.

The herd should be kept free from lice and mange at all times. Every hog should be sprayed with some standard dip at frequent intervals, and it is a good practice to dip them every six or eight weeks during the summer. If sanitary wallows are provided, hogs need not be dipped so often.

A mixture of wood ashes and salt with a little sulphur added should be kept before the hogs at all times, or if wood ashes are not available, the government hog tonic<sup>1</sup> should be used instead. Both of these mixtures should be fed from a clean box placed where it is protected from rain and snow.

<sup>1</sup> Wood charcoal, 1 pound; sulphur, 1 pound; sodium chloride (common salt), 2 pounds; sodium bicarbonate (baking soda), 2 pounds; sodium hyposulphite, 2 pounds; sodium sulphate (Glauber salt), 1 pound; and antimony sulphide (black antimony), 1 pound.

## QUESTIONS AND PROBLEMS

1. Describe the characteristics and relative values of the two distinct types of hogs.
2. How did the different breeds of the lard-type hog come to be developed?
3. Give the characteristics of each of the lard types of hogs; of the bacon types.
4. Visit the barns of a successful hog grower and determine what are the essential points to be observed in the management of a herd; in the construction of buildings for hogs.
5. In what ways does the care of breeding stock differ from that of hogs which are being fattened?
6. Secure the exact records of the number of brood sows used last year on three different farms of your locality and the number of pigs raised, and thus determine the average number of pigs to each brood sow for the twelve months.
7. If possible, secure the record of the number of pigs raised by a brood sow of prolific tendency, and compare her production with the average production of the three farms just mentioned.
8. If it is possible for some member of the class to do so, secure a young brood sow whose dam and sire are of known prolific parentage. Keep a school record from year to year of the production of this sow.
9. What are the essential points to be observed in feeding young pigs?
10. When and how should pigs be weaned?
11. Discuss each of the two systems of fattening hogs for market. What advantages are possessed by each system?
12. According to the experiments which are reported, what constitutes the best-balanced ration for hogs?
13. What is the value of alfalfa hay in fattening hogs?
14. What kinds of hog pasture have proved to be the best in feeding and fattening hogs?
15. Compare the advantage of slow and of rapid gains in the fattening of hogs. Is slow production or rapid production of hogs most used in your locality? Which is regarded as the more profitable?
16. What special care should be taken of the hog pens and yards?
17. How may the common diseases of swine be prevented?
18. Secure from your state agricultural college full directions for the treatment in the control of hog cholera and make this information the basis of a class discussion. Secure records of experiments in using these directions.

## REFERENCES

- COBURN, F. D. Swine in America. Orange Judd Company.
- DAWSON, H. C. The Hog Book. Saunders Publishing Company.
- DAY, GEORGE E. Swine. Kenyon Printing Company.
- DIETRICH, WILLIAM. Swine. Saunders Publishing Company.
- Hog Cholera, *Farmers' Bulletin 379*, United States Department of Agriculture.
- Feeding Hogs in the Southern States, *Farmers' Bulletin 411*, United States Department of Agriculture.
- Hog Houses, *Farmers' Bulletin 438*, United States Department of Agriculture.
- Boys' Pig Clubs, *Farmers' Bulletin 566*, United States Department of Agriculture.
- Pasture and Green Crops for Hogs on the Pacific Coast, *Farmers' Bulletin 599*, United States Department of Agriculture.
- The Corn Belt System of Farming which Saves Harvest Labor by Hogging down Crops, *Farmers' Bulletin 614*, United States Department of Agriculture.



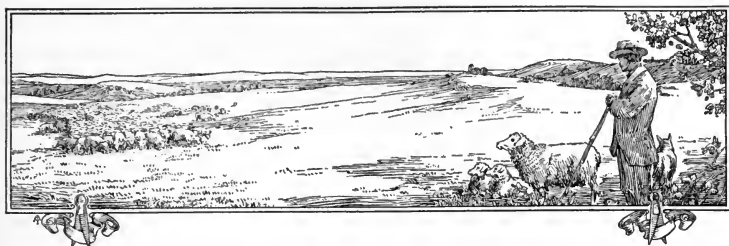

## CHAPTER XXXIV

### SHEEP

**538. Development of types.** It is not known where sheep originated, but they have been associated with man throughout his known history. They thrive and are profitable when grown on the most fertile lowlands, where intensive systems of farming are practiced, and they are thrifty and contented on the most bleak and rugged mountains or on the parched plains.

In ancient times, as to-day, sheep were raised for both food and raiment. In modern times special types of sheep have been developed. Some of these are especially adapted to the production of wool and others to the production of meat. One of these is the fine-wool type and the other is the mutton, or the medium-wool and long-wool type.

**539. Characteristics of types.** The fine-wool sheep, like the dairy cow, is inclined to be angular in form. It possesses less thickness of back, loin, and leg than does the mutton sheep.

The Down breeds of sheep usually are spoken of as the medium-wool breeds. They are raised primarily for mutton, with wool as a secondary consideration. The form of the mutton sheep is blockier, smoother, and more compact than that of the fine-wool sheep, and it has a wide and thick-fleshed back and loin and a heavy, thick leg. The fleece of the medium-wool sheep, as compared with that of the fine-wool sheep, contains less yolk, or oil, and is lighter and not so dense. Also, the crimp is not so fine, which indicates that the staple is somewhat coarser.

Sheep of the long-wool breeds that are most important in this country are larger and more upstanding than those of the medium-wool breeds, but as a rule the body of this type of sheep is of the same general mutton form as that of the medium-wool type. The fleece is heavy and much more open than that of the medium wools, and the staple is long and comparatively coarse.

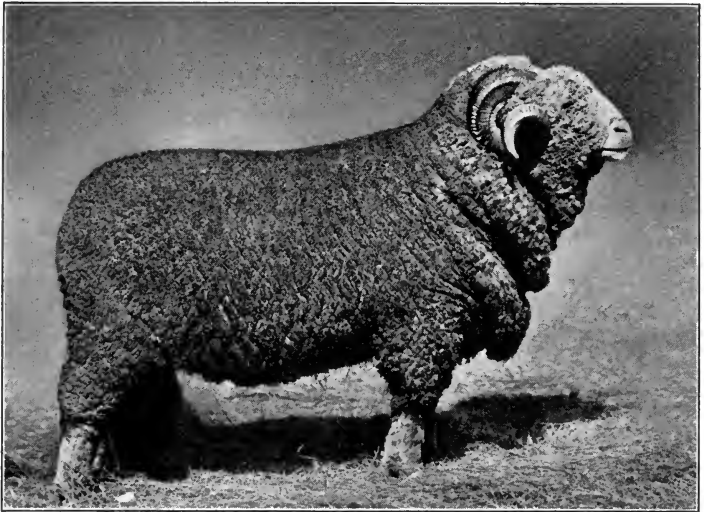

FIG. 207. American Merino

Note the characteristic wrinkled skin, fine, oily fleece, heavy horns, and hairy legs, face, and nose

**540. The fine-wool breeds.** The breeds of fine-wool sheep are as follows: American Merino, which originated and developed in Spain and later was improved in the United States; Delaine Merino, which developed in the United States; and the Rambouillet, which developed in France.

**541. The American Merino.** The American Merino (Fig. 207) developed under migratory conditions; therefore the habit of sheep of this breed to flock or stay together when on the range was early fixed. This tendency to flock has given the Merino first place as a sheep suitable for our Western-range conditions.

The Delaine and the Rambouillet, which in reality are offshoots of the early Spanish type of Merino, have inherited the same characteristic.

The Merino was first brought into the United States probably about 1792. At present it is raised more extensively on the sheep farms and ranges of the West than in the East. It is the smallest of the fine-wool breeds and furnishes the finest and heaviest fleece of any of the breeds. The fleece of the Merino completely covers the body and legs, and the wool is of good length and fine, with an excellent crimp and an abundance of yolk. The head is small, the nostrils and lips white. The wool grows below the eyes well down on the nose, and the muzzle and nose are covered with fine white wool. The skin should be a bright pink and cover the body in folds, or wrinkles, thus giving more surface for the production of wool. The rams have horns, and the ewes are hornless.

**542. The Delaine Merino.** The Delaine Merino has been developed in the United States from the American or Spanish Merino, in order to secure a better mutton sheep. This sheep is larger than the American Merino, has a smoother, fuller body, and has fewer folds, or wrinkles, of the skin. The wool is longer — the staple being about three inches in length — and the weight of the fleece is less. The color is the same as the American Merino, and the wool covers the face and legs in the same way.

**543. The Rambouillet.** The Rambouillet originated in France from Spanish Merino stock to meet the demand for a fine-wool sheep that would produce more mutton. It was introduced into the United States in 1840, and has since become popular, especially on the Western ranges. This sheep does not differ essentially from the Delaine, except that it is larger, has fewer folds, and produces a better mutton carcass.

**544. Middle-wool breeds.** The most important breeds of sheep, usually classed as middle-wool, are the Southdown, the Shropshire, the Hampshire Down, the Oxford Down, and the Dorset. All these breeds were developed in England.

**545. The Southdown.** The Southdown (Fig. 208) is the oldest and smallest of the Down breeds. It originated in southeastern England in the hills known as the Southdowns. The breed was introduced into the United States probably during the colonial days. It is thought by many to approach most nearly to the ideal mutton form. It is short-legged, thick-fleshed, broad, blocky, and compact. Sheep of this breed are alert and active, and have stylish carriage. The fleece is short, of medium quality,

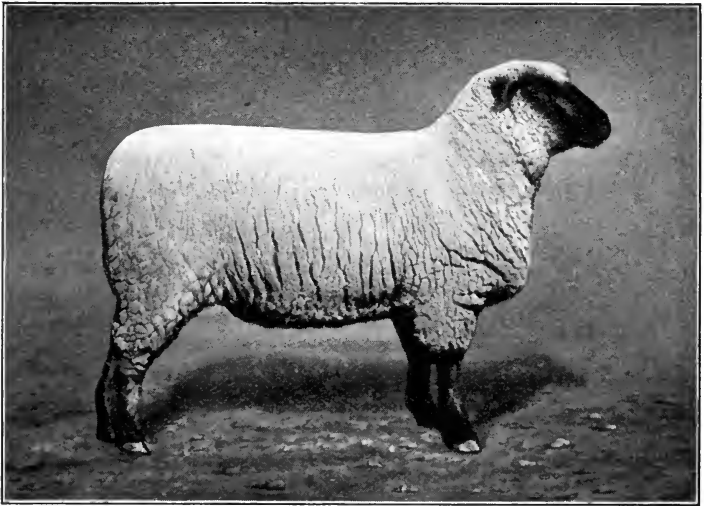

FIG. 208. The Southdown

Compact, square body, dense wool, and clean legs and face

dense, and covers the head and neck to the eyes, and the legs down to the knees. The face and legs are grayish brown. Both ewes and rams are hornless.

**546. The Shropshire.** The Shropshire breed (Fig. 209) originated in western England. It was introduced into the United States about 1860. This breed has proved very popular in America, especially on the farms of the eastern and central states. It is larger than the Southdown. It has an excellent mutton form, though not quite so compact as the Southdown.

The fleece is heavier, with a longer staple of medium quality. The fleece covers the body and legs, and the face down to the nose. The ear is small and short and shows quality. The color of the face, ears, and legs is a dark brown or blackish brown. Both ewes and rams are hornless.

**547. The Hampshire Down.** This breed of sheep originated in south-central England and was introduced into the United States about 1855. Hampshire lambs mature quickly and fatten

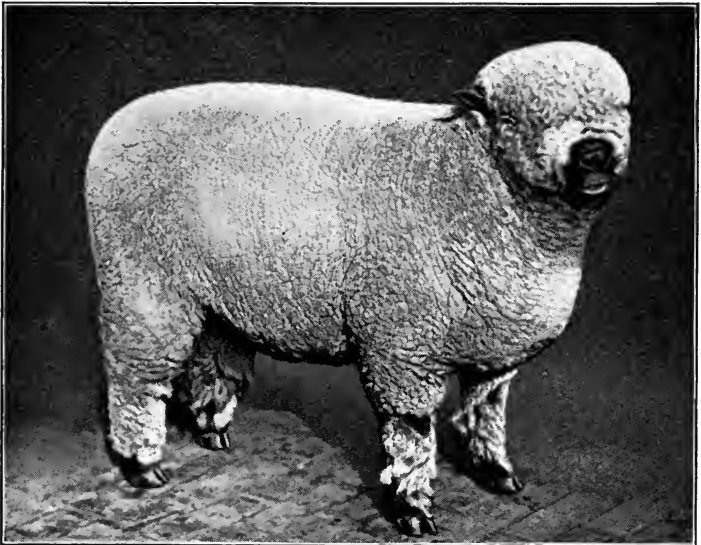

FIG. 209. The Shropshire

Good body, good fleece, and hairy legs, face, and nose

readily. The Hampshire is a little more rangy and upstanding than the Shropshire, and is one of the largest of the Down breeds. The head, ears, and legs are dark brown or black (Fig. 210). The lips and nostrils are black. The Hampshire head is large, and the nose has a Roman profile. The ears are large and long, are carried outward and somewhat drooping, and are somewhat more pointed than in the Shropshire. Both ewes and rams are hornless.

**548. The Oxford Down.** The Oxford Down sheep originated in the county of Oxford, England. This breed, compared with the other Down breeds, has been developed recently. It was first brought to this country about 1846. At first glance the Oxford resembles the Shropshire, but it is a larger sheep than

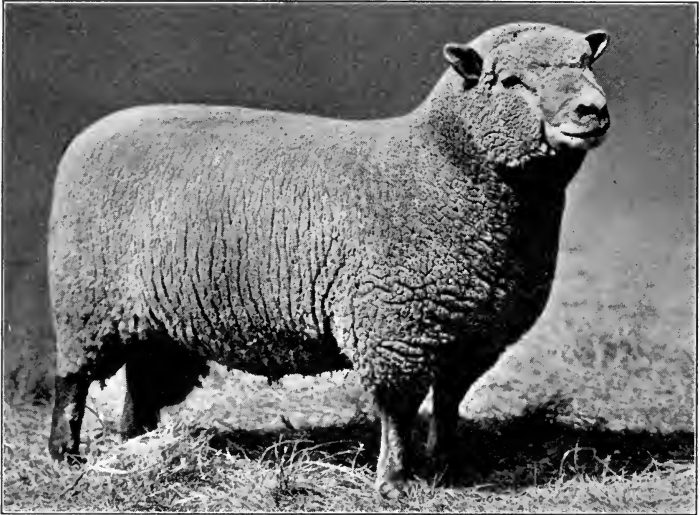

FIG. 210. Cross between Shropshire and Hampshire

This cross produces an excellent type of sheep. In the specimen here shown the Hampshire characteristics are most prominent—large body, dark face and legs, and slight tendency toward ranginess

either the Shropshire or Hampshire, and the face, ears, and legs are lighter brown. The wool covers the forehead, but not quite so heavily as in the Shropshire, though with a longer, looser forelock. The ears point outward and usually are long, thin, and free from wool. Like the Shropshire and Hampshire this breed is hornless.

**549. The Dorset Horn.** The Dorset Horn breed originated in southern England. Sheep of this breed were not brought to America until 1885. It is noted for the production of early lambs. In form the Dorset is essentially of the mutton type.

In comparison with the other mutton breeds, it ranks as medium in size. The face, nostrils, ears, legs, and hoofs are white. The body is covered with a medium-fine fleece extending over the neck and head to the eyes, and over the legs to the knees and hocks. Both ewes and rams have horns characteristic of the breed.

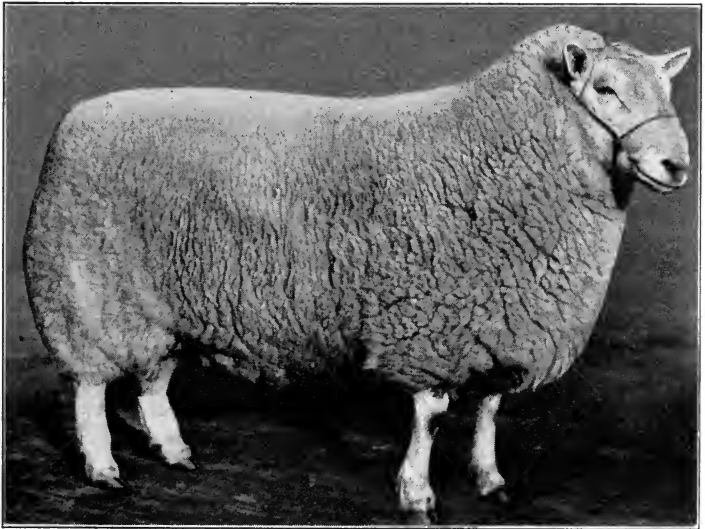

FIG. 211. The Cheviot

Long, loose wool reaching to the knees and hocks and growing back of the ears; clean poll, face, and nose

**550. The long-wool breeds.** The breeds of long-wool sheep most important in this country are the Leicester, the Cotswold, and the Lincoln, all developed in England.

**551. The Leicester.** The Leicester originated in central England and is the oldest of the improved English breeds. The first importation to the United States was about 1800. It is the smallest of the long-wool breeds, is alert and rangy, while the body is wide and of medium depth. The fleece is fine, covering the body to the back of the ears, and the legs to the knees and hocks. This breed is hornless.

**552. The Cotswold.** The Cotswold originated in southwestern England. It was developed to meet the demand for a sheep that would make the most economical gains from coarse forage. Sheep of this breed were brought to the United States about 1832. The characteristic feature of the Cotswold sheep is the head. The forehead is broad; the face is white or spotted with gray and has a tendency toward a Roman profile; and the nostrils are black. Extending down over the forehead, often to the nostrils, are heavy locks or curls. The back is broad and strong. The fleece covers the body in large locks or curls. The staple is long and of good quality. The ears and legs are marked much like the face. Both sexes are hornless. The Cheviot breed of sheep (Fig. 211) closely resembles the Cotswold.

**553. The Lincoln.** The Lincoln sheep was developed in the eastern part of England, in the county of Lincoln. This breed was brought to America in the latter part of the eighteenth century. It is the largest of the long-wool breeds. It is white, though there is sometimes a mixture of gray in the face. The head is large and strong. The body has good length and depth, and is covered with firm flesh. The fleece is long, coarse, and curly. The wool extends to the knees and hocks, and sometimes below the hocks. The forehead is covered with a short lock of wool.

Since ancient times the sheep has been called "The Golden Hoof," because it cleared and enriched the land upon which it fed; also, because it was believed that the sheep returned a greater profit upon the money invested, and the feed and care required, than did any other kind of farm animal. It is probable that sheep make a pound of live-weight gain on less feed than any other meat animal. It is generally estimated that the fleece will pay for keeping the ewe, thus leaving the lambs as profit. Another profit in keeping sheep relates to the control of weeds. When given the opportunity, sheep will eat almost all kinds of farm weeds. Farms upon which mixed husbandry is practiced can well afford to keep at least a small flock of good sheep.



## QUESTIONS AND PROBLEMS

1. In what ways were sheep associated with the early history of man?
2. What are the characteristics of the two distinct types of sheep?
3. Describe the leading characteristics of each of the leading breeds of fine-wool sheep.
4. Describe the leading characteristics of each of the long-wool breeds.
5. What are the different breeds of sheep grown in your locality?
6. What is the importance, in comparison with other farm animals, of sheep-growing in your county?
7. To what extent are sheep shipped into your locality for feeding? Where do these sheep come from?

## REFERENCES

- CRAIG, J. A. Sheep Farming in North America. The Macmillan Company.
- DOANE. Sheep Feeding and Farm Management. Ginn and Company.
- KLEINHEINZ, FRANK. Sheep Management. Published by the author, Madison, Wis.
- WING, J. E. Sheep Farming in America. Saunders Publishing Company.
- Mutton and its Value in the Diet, *Farmers' Bulletin 526*, United States Department of Agriculture.
- Breeds of Sheep for the Farm, *Farmers' Bulletin 576*, United States Department of Agriculture.

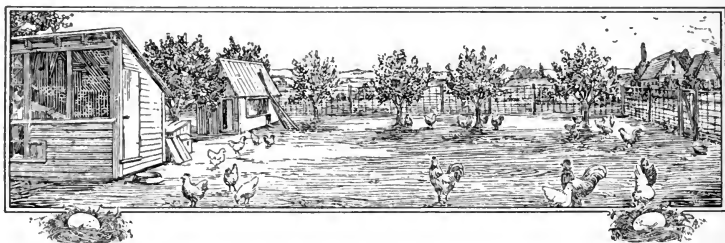

## CHAPTER XXXV

### POULTRY

**554. Importance of the poultry industry.** The value of the poultry and eggs produced in the United States annually is about \$750,000,000, or about the same as the combined value of the gold, silver, iron, and coal mined annually in the United States. The value of the poultry and eggs sold from farms, not including that raised in the towns and villages and sold, is \$256,000,000. The average farm income from poultry products in the United States in 1913 was \$92.39 for each farm. In the same year the value of poultry raised on farms was 16.9 per cent of the value of all farm-animal products.

**555. Poultry is chiefly chickens.** Ninety-five per cent of all the poultry in the United States is chickens; 1.5 per cent is geese; 1 per cent is turkeys; less than 1 per cent is ducks; guineas, pigeons, pheasants, and other domestic birds make up the remaining 1.5 per cent.

The popularity of the chicken is due to the fact that it furnishes a convenient source of fresh meat on the farm and is usually a much better egg producer than other species of poultry.

**556. The primary poultry product.** Eggs furnish two thirds of the farm income from poultry, and meat and feathers the other third. The reason for this probably lies in the fact that eggs are highly digestible and generally desired as a food. The eggs of ducks, geese, and guineas are sometimes sold for food, but the number is so small when compared with hens' eggs as

to make them a negligible quantity. Turkeys' eggs are used for hatching purposes only and usually command good prices.

**557. Classes of chickens.** There are three terms used to distinguish the different kinds of chickens — class, breed, and variety. Class refers to a group of breeds having a common place of origin, or the same general characteristics, or both. The classes most frequently met with are the Asiatic, Mediterranean, American, and English.

The Asiatics (Fig. 212) originated in Asia and are distinguished by their large size, feathered legs, low egg production, dark-brown eggs, and slothful temperaments. The Mediterraneans originated in the vicinity of the Mediterranean Sea. They may be recognized by their comparatively small size, featherless legs, pure-white eggs, and nervous, active dispositions.

They are the best among all the classes for egg production (Fig. 213). The American and English classes originated in America and England, as their names indicate. Both are about halfway between the Asiatics and the Mediterraneans in size, disposition, and egg production, and in the color of the eggs. They have no feathers on their legs. The American breeds have yellow legs, while the English have white; there is also a similar difference in the color of the flesh throughout the body, the American being darker in color.

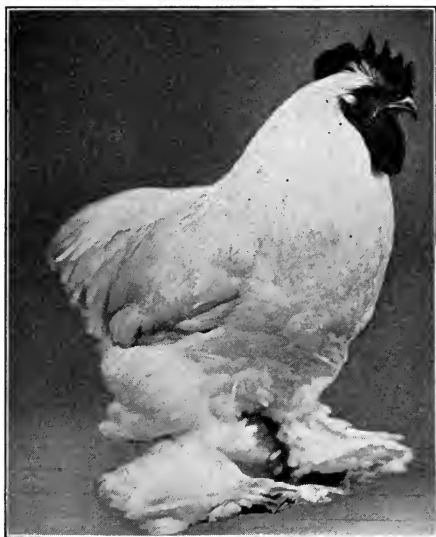

FIG. 212. White Cochin

The White Cochin shows the characteristic bulk of the Asiatic class of chickens

**558. Breeds and varieties of chickens.** There are six American breeds, three of which are common and three less common. The three common breeds are the Plymouth Rock (Figs. 215 and 218), Wyandotte (Figs. 219 and 220), and Rhode Island Red (Fig. 214). Those which are less common are the Dominique, Java, and Buckeye. There are three Asiatic breeds — the Brahma, Cochin (Fig. 212), and Langshan — all of which

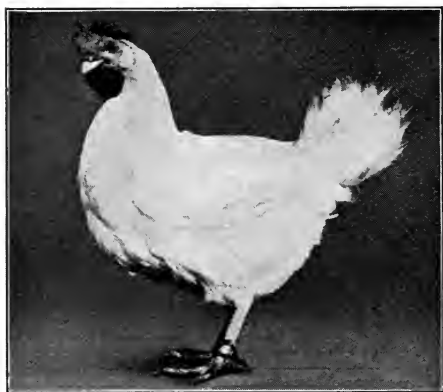

FIG. 213. The world's-record Leghorn hen

This hen, the property of the Oregon Agricultural College, laid 303 eggs in twelve months (1913). The picture was taken on the day following the completion of her year's work

were formerly quite common but are gradually becoming less common because they mature slowly and do not lay as well as the other breeds. The Mediterranean breeds are the Leghorn (Fig. 213), Minorca, Spanish, Ancona, and Blue Andalusian. Of these, the Leghorns are more common than all the others together. The Minorcas and the Anconas are seen now and then, but the Blue

Andalusians and the Spanish are very rare. The English breeds recognized are the Dorkings, Red Caps, and Orpingtons (Fig. 221). Of these, only the Orpingtons are common.

A variety is a group within the breed distinguished by the color and the kind of comb. Barred Plymouth Rocks and White Plymouth Rocks are varieties of the same breed, the point of distinction being color. Single-comb Rhode Island Reds and Rose Comb Rhode Island Reds are varieties which have the same color but different kinds of comb. The single and rose-combed varieties of chickens have differences other than the structure of the comb, but this is the most conspicuous difference.

**559. Farm poultry.** The number of pure-bred chickens is increasing, because farmers are discovering that they can feed a uniform flock very much more profitably than one that contains several types of birds (Fig. 215). Uniformity is necessary, too, for the successful marketing of poultry products. Uniform stock, however, will not yield greater profits than mongrel stock unless it receives intelligent care. Like other stock, it must be

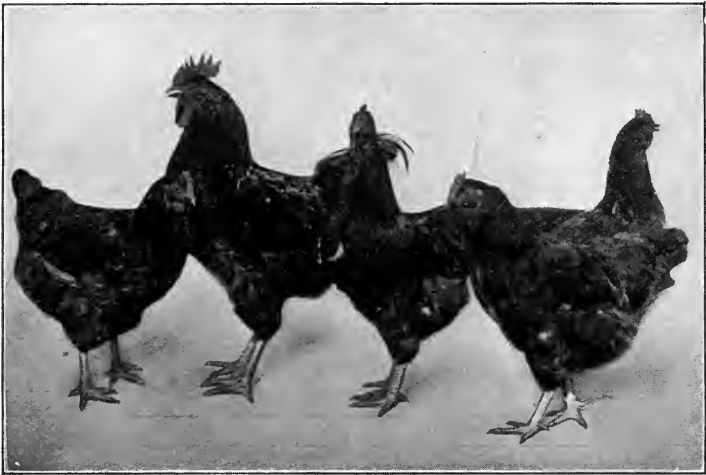

FIG. 214. Rhode Island Red chickens

well housed and skillfully fed, and attention must be given to rearing the young.

**560. The essentials of a good poultry house.** There are four essentials to a successful poultry house — dryness, good ventilation without drafts, sunlight, and plenty of room (Figs. 216 and 217).

Dryness is essential because chickens eliminate proportionally more moisture through the breathing apparatus than do other farm animals; also, the pasty excreta from the body evaporate moisture into the air. Dry air more readily removes surplus moisture. Good ventilation is essential, since it aids in keeping the house dry by carrying off excessive moisture and

harmful gases. Hens require more air per unit of weight than other farm animals. It has been estimated that a 1000-pound cow breathes 2804 cubic feet of air in twenty-four hours, that a 1000-pound horse breathes 3401 cubic feet in the same time, while 1000 pounds of hens require 8278 cubic feet.<sup>1</sup> In the henhouse where there are a good many birds, if the poisonous gases produced by the fowls are not carried off, they will be

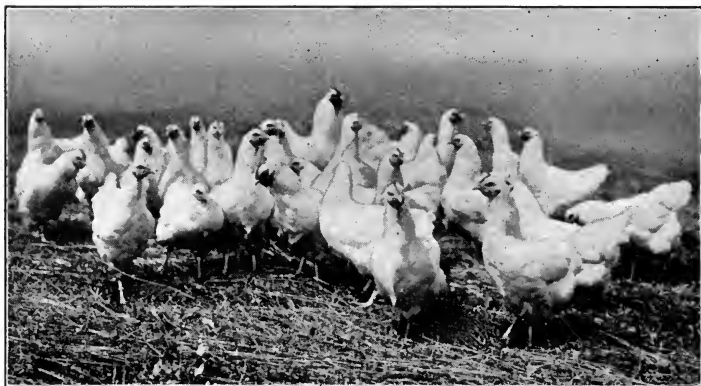

FIG. 215. White Plymouth Rocks

breathed repeatedly, to the great injury of the fowls. Sunshine is essential because it helps keep the house dry, makes it more cheerful, and is a great germ destroyer.

Although chickens are many more generations removed from their wild ancestors than are turkeys, nevertheless both are still very sensitive to crowding. Under conditions of domestication the flocks are large and are likely to be crowded into a rather small house. To promote egg production and insure health it is wise to provide  $4\frac{1}{2}$  or 5 square feet of floor space for each chicken.

**561. Sanitation in chicken houses.** Surface parasites and disease are dangers that constantly beset chickens. The successful poultry keeper must continually guard against these things.

<sup>1</sup> King, *Physics of Agriculture*, p. 355.

The common external parasites of the chicken are the louse and the mite. Lice lay their eggs at the base of the feathers and pass their whole life among the feathers, feeding on the scurf produced by the skin. They do not usually injure mature birds, though if they become too numerous they irritate them, making them nervous and uncomfortable, and thus check egg production. Chickens should have plenty of road dust or sifted

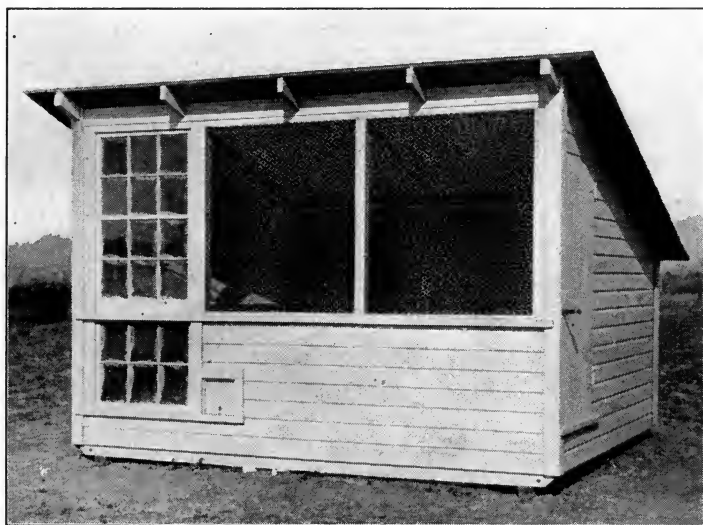

FIG. 216. A good style of chicken house

coal ashes in which to wallow whenever inclined. The fine particles of dust lodge in the breathing pores of the lice and kill them.

Mites do not live continually on the body of the hen, as do lice. They are tiny, spiderlike organisms without eyes, and possess piercing mouth parts by means of which they suck blood from the body of the chickens. They live in the crevices of the boards surrounding the perches or nests, and go upon the chickens only for the purpose of feeding. When filled with blood, the mites again hide in the crevices. Mites are much

more serious pests than are lice, and every reasonable precaution should be taken to insure their absence. The eggs of the mites are laid in the filth that accumulates about the roosts. When mites have been discovered in a poultry house, the entire interior of the house should be sprayed at once with kerosene, or with a 3 per cent solution of a good coal-tar stock dip, care being taken to soak the crevices. One spraying is not enough,

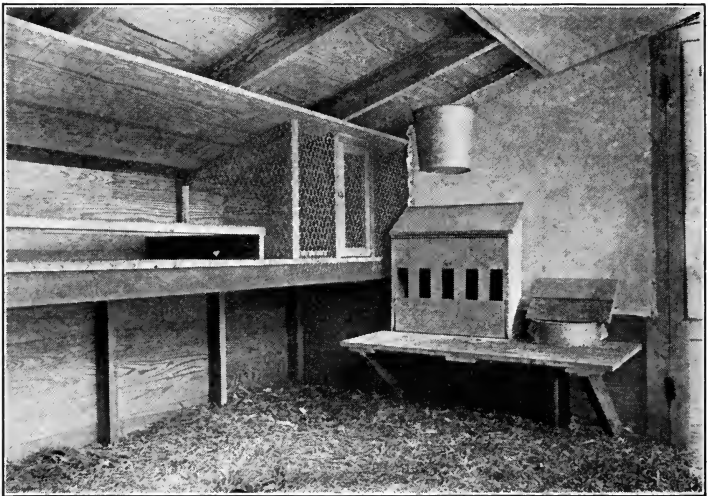

FIG. 217. Interior of a good chicken house

Showing perches, dropping board, broody coop, feed hopper, and watering appliance.  
(Photograph from Purdue Experiment Station)

because it kills only the living mites and does not injure the eggs, particularly if they are well covered. The eggs will hatch in from four to six days in warm weather, and in from seven to ten days in cool weather, and the time of the second spraying should be governed by the temperature. Spraying for mites also helps to guard against other poultry diseases. The chicken house should be thoroughly sprayed at least twice a year even if no mites appear, and it should always be sprayed after any outbreak of disease.



**562. Feeds and feeding.** Chickens require concentrated feed made up chiefly of grains and grain by-products. They also require relatively more protein than do most other farm animals. Better results are obtained if a considerable part of the protein is furnished from animal sources. In spring and summer the fowls, if they are allowed the run of the fields, pick up animal protein in the form of bugs, grubs, and worms. In winter, however, it should be furnished them in some such form as meat scraps or milk.

Poultry in general, and more particularly the good layers, need a very much higher percentage of ash (out of which to make eggshells) than is required by other farm animals, and more than is furnished by the common grains. It is because of this that the excellent practice of furnishing chickens with a constant supply of oyster shell has become common.

Charcoal should also be kept before the fowls at all times. This is not feed, but regulates the digestive process.

Since the chicken has no teeth, it grinds its feed in the gizzard with the help of pebbles or little pieces of stone (usually spoken of as grit), a supply of which should be available to the birds at all times. Hens will lay better if part of this grinding is done for them. Therefore ground grain should form a part of the ration, a satisfactory proportion of ground grain to whole or cracked grain being one to two.

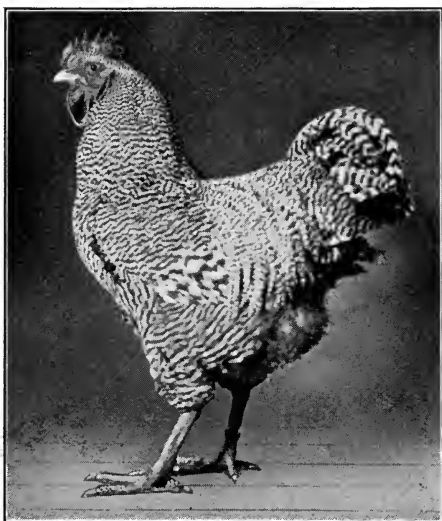

FIG. 218. The Barred Plymouth Rock  
The most widely used American breed

**563. The scratching feed and the mash.** The whole or cracked grain portion of the ration is usually spoken of as the scratching feed, because it is scattered in a deep litter of straw, so that the birds will have to take plenty of exercise in scratching it out. The ground part of the ration is usually referred to as mash. It may be moistened with sour milk or with water, or it may be



FIG. 219. White Wyandottes

fed dry. Dry mash is usually fed from a hopper, so that the chickens may help themselves at will.

In the spring, if the chickens are allowed to have the run of the farm, besides being able to get bugs and worms in abundance, they can also pick up tender, green vegetation in many forms. The fact that these two kinds of feed are plentiful at that time of year is one of the reasons why hens lay more eggs in the spring of the year than during the fall and winter. Hens depend on good pasture a great deal more than is generally

supposed, and green food should be a part of the ration the year round. During the winter months it may be furnished in the form of sprouted oats, mangel beets, or cabbage. Steamed alfalfa, clover or cowpea leaves, or even the leaves as they shatter from the hay, form a good substitute for fresh vegetation, but are not so good as succulent food.

**564. Typical rations for laying hens.** The following grain ration is good for a mixed flock of laying hens :

3 parts wheat  
2 parts cracked corn or kafir  
1 part oats

This should be fed with a dry mash from the following stock mixture :

60 pounds corn meal	30 pounds wheat bran
60 pounds wheat middlings, or shorts	10 pounds alfalfa meal
50 pounds meat scraps	10 pounds linseed-oil meal
	1 pound salt

A good dry-mash ration for laying hens of the Mediterranean or lighter varieties is as follows :

	PARTS BY WEIGHT
Corn meal . . . . .	3½
Wheat bran . . . . .	5½
Wheat middlings, or shorts . . . . .	3
Linseed meal . . . . .	1
Meat scraps . . . . .	2½

The scratching part of this ration should be whole corn and wheat in equal parts. During the winter, silage may be used freely in place of green feed. Oyster shell, grit, and charcoal should be constantly before the fowls.

**565. How and when to feed.** In the morning a light feed of whole and cracked grain should be scattered over the feeding floor in a deep litter of straw. At noon the mash hoppers should be opened and they should be left open throughout the afternoon. Green feed should also be fed if the birds are confined or if the ground is frozen. The amount given should be about what they will eat in from twenty minutes to half an hour.

Fresh water should be given in the morning and at noon. In warm weather it should be given again in the evening. While the mash hoppers are left open during the entire afternoon, there is little danger of the hens overeating, because they prefer the whole or cracked grains, and usually will be found eager for their evening meal of scratching feed.

The amount fed in the evening should be what the fowls will clean up before going to roost. If upon feeling of the fowls'

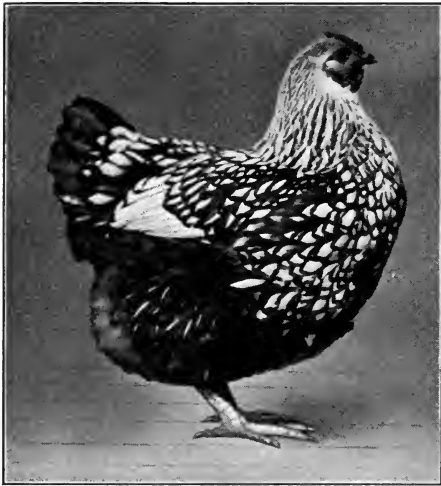

FIG. 220. Silver-Laced Wyandotte hen

crops after they are on the perch they are not well filled, not enough grain has been fed. If some of the grain in the litter remains uneaten after the birds have finished, the fowls have been fed too much. It is more desirable from the standpoint of egg production to underfeed slightly than to overfeed, because when overfed and inactive, hens lay less in proportion to the feed given than when they are

somewhat hungry. The really skillful feeder keeps the appetite stimulated and the birds thrifty and hustling, by never feeding quite as much as they would like to eat, yet always sending them to roost with full crops.

**566. Rations for young chicks.** For the first two days young chicks should not be fed or watered, as the nourishment required during this period is provided in the egg. From that time on they should be fed frequently (at least five times daily if they are kept in brooders) on infertile eggs tested out of the incubator, hard-boiled and ground fine (shell and all) in a meat

chopper, thoroughly mixed with about six times their bulk of rolled oats. Beginning about the sixth day, the following grain mixture may be given :

	PARTS BY WEIGHT
Cracked wheat . . . . .	15
Pinhead oatmeal . . . . .	10
Finely cracked corn . . . . .	15
Finely cracked peas . . . . .	3
Broken rice . . . . .	2
Fine grit . . . . .	5
Fine charcoal . . . . .	2

As soon as the chicks can eat whole wheat and coarsely cracked corn, they should have these instead of the finely cracked grains.

When the chicks are taken from the brooders and put on range, they may be fed entirely in the hopper, since they have an abundance of exercise in chasing bugs and scratching for worms. Cracked corn, wheat, cracked bone, ground oyster shells, and grit may be placed in separate troughs, as is also the following dry-mash mixture :

	PARTS BY WEIGHT
Wheat bran . . . . .	1
Corn meal . . . . .	2
Wheat middlings . . . . .	1
Meat scraps . . . . .	1

**567. Saving eggs for hatching.** Eggs for hatching purposes should be put under the hen or into the incubator as soon as possible after they are laid. When it is necessary to save them until the number desired has been accumulated, they should be kept in a cool, dry place and turned once every day. Eggs begin to develop into a chick very slowly at 68 degrees F. The rate of development increases until the temperature reached is 103 degrees F., when the rate of development becomes normal. Slow or abnormal development injures the vitality of the embryo chick. Eggs saved for hatching should therefore be kept at a temperature below 68 degrees F. A temperature between 55 degrees and 65 degrees F. has been found to be the best for this purpose.

**568. Incubating.** The germ spot on the yolk of an egg is always at the uppermost point. If an egg is turned, the yolk will slowly rotate inside the shell until the germ comes to the highest point. This serves to bring the germ, which develops into a living chick, near to the warm body of the sitting hen.

A fertile egg will develop into a chick in twenty to twenty-one days if the temperature at the level of the top of the egg is

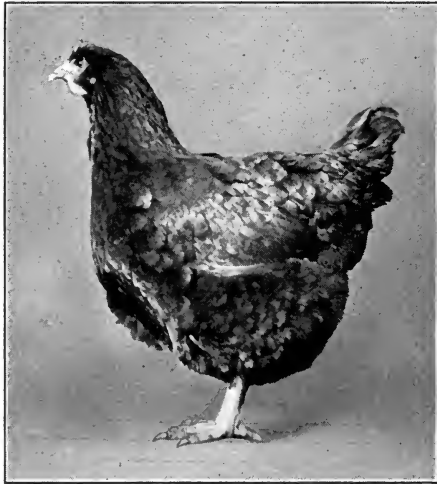

FIG. 221. Black Orpington hen

A popular representative of the English class

kept at 103 degrees F. The temperature of the hen's body is usually 106 degrees F., and the top of the egg will generally be found to be about 103 degrees F.

It has been found that by furnishing the same temperature by artificial means, eggs may be successfully hatched. Boxes (called incubators), heated by an oil lamp with an automatic damper that opens to allow the escape of heat if it is too high, or closes to hold more heat in the

box when it is too low, are used very successfully for hatching eggs.

**569. Managing an incubator.** The incubator should be kept in a room where the temperature is fairly uniform. For this reason a cellar is often used, being found more satisfactory than a living room, which is likely to be too cool at night. Care must be taken to see that the top of the incubator is level, so that the heat will be evenly distributed.

After the lamp has been lighted, the regulator should be adjusted until an even temperature of 102 degrees F. or 103 degrees F. is maintained at the level of the top of the eggs.

Except in very wet climates, a pan of water, with a sponge to furnish an evaporating surface, should be placed below the egg trays to keep the air moist. The incubator is then ready to receive the eggs. Beginning the third day, the eggs should be taken out and turned gently three times a day. Once a day, after turning, they should be left out long enough to feel cool to some sensitive part of the body, such as the lips or eyelids. This corresponds to the change in temperature when the hen leaves the nest to eat, and results in an improved hatch.

This routine should be followed until the eighteenth day, when the temperature may be allowed to reach 104 degrees F. but must not go above 105 degrees F. The door of the incubator should be kept closed from this time until after the hatch is over. The moisture pan should be removed and the egg tray arranged so that the chicks may



FIG. 222. A simple device for inspecting eggs  
The tube, or "candle," here shown was made from coarse paper. The egg is candled either by use of strong sunlight or by use of a lighted lamp

drop down into the nursery bottom of the incubator. The chicks should be left in the nursery, without feeding, for thirty-six hours or more, until they call vigorously for something to eat.

On the seventh and fourteenth days it is customary to test out infertile eggs, or those whose germs show unmistakable evidence of having died (Fig. 222). This gives more room for the chicks to hatch, and prevents the dead eggs from becoming putrid.

**570. Brooding.** When incubators are used for hatching, in the place of hens, something must be provided to take the place of the mother for brooding (Fig. 223). For this purpose boxes, somewhat differently shaped from incubators but heated

in much the same way, are used and are called brooders. Besides keeping the chicks warm, the brooder must be well ventilated, as was suggested in the construction of houses for mature stock.

When the chicks are first removed from the incubator, the temperature under the hover (the warmest compartment of the brooder) should be about 100 degrees F. The usual custom is to reduce the temperature at the rate of about five degrees a week. This should be governed by judgment rather than by rule. The temperature should be as low as is consistent with keeping the chicks warm enough to prevent them from crowding.



FIG. 223. A brooder; heating-lamp outside

**571. Saving eggs for market.** When not cared for properly, eggs will spoil almost as quickly as milk or butter. An egg is never again so good for table purposes as when it is

perfectly fresh. Therefore, in saving eggs to sell, the effort should be to keep them as nearly as possible in the condition in which they were when newly laid. Eggs lose their freshness by shrinking, incubating, becoming watery, molding, or absorbing odors. These defects increase with age, and the egg should therefore be marketed as soon as possible after being laid.

If a newly laid egg is held before a candle or tester, the contents will be found to fill the shell completely. When the egg has become cool, its contents contract, and a small air space known as the air cell may be seen at the large end. As the egg grows older, this space increases in size. If the eggs are kept in warm air or if anything is done that opens the pores, evaporation is



rapid. When first laid, the egg is covered with a mucilaginous coating which quickly dries, and is referred to as the bloom of the egg. This coating, which nearly closes the pores of the shell, quickly dissolves if the egg is washed, thus leaving the pores exposed not only to rapid evaporation but to the entrance of bacteria and molds. If the shrinkage is to be kept at the lowest point, it is necessary to keep the eggs as cool as possible without freezing, and to keep them clean by the use of clean, dry nests.

**572. Infertile and fertile eggs.** It is very much easier to keep eggs fresh when they are kept infertile by separating the male birds from the laying flock after eggs for hatching are no longer desired. It takes but two or three days at summer temperature for fertile eggs to become unfit for food.

Whether fertile or infertile, the eggs should be gathered daily — and in very warm weather twice daily — and put immediately into a cool, dry, well-ventilated cellar. Never market eggs that are found in stolen nests or are of unknown age.

**573. Best eggs for the highest market.** Eggs that are kept warm for any considerable length of time become watery and soon decay. Therefore eggs should be cooled as soon as laid and should be kept in a cool, well-ventilated place, and marketed in as cool condition as possible.

It should be remembered that eggs must be kept cool while on the way to the market as well as while on the farm. In taking eggs to the market they must be protected from the sun's rays. It is a good plan to have a marketing box or basket so made that the eggs may be kept cool and not exposed to excessive lighting.

While evaporation is checked by a damp atmosphere, the damage resulting from the growth of molds and bacteria is so great that a damp atmosphere should be avoided.

Eggs, like butter and milk, quite readily absorb taints and odors. For example, if eggs are kept in a musty cellar, or in a refrigerator with onions, turnips, lemons, or fish, they soon taste of these things. A really first-class egg must be large, clean without having been washed, full, free from cracks, and without indication of mold or chick development.

## QUESTIONS AND PROBLEMS

1. Compare the total value of the eggs and poultry produced annually in the United States with the value of mineral products.
2. Why is the chicken the most popular species of poultry?
3. Name four common classes of chickens, giving the distinguishing characteristics of each.
4. What is the difference between a breed and a variety?
5. Give reasons why pure breeds of poultry are better for the farm than mongrels.
6. What are the essentials of a good henhouse?
7. Describe the parasites known as lice and mites, and explain how to control each. If specimens can be found, study them by use of hand magnifying-glasses.
8. How are ventilation and sunshine in the chicken house related to the health of chickens?
9. With the feeds available at home or in your local market as the basis, prepare a chart, giving a proper spring ration for a flock of mixed poultry; a proper winter ration for the same flock.
10. Why are grit and oyster shells important in feeding chickens?
11. What important differences are there in content and in use between scratching feed and dry mash. What feeding regulations should be observed?
12. Describe when, how, and what to feed newly hatched chicks. How does the proper feeding of such chicks compare with the proper feeding of growing chicks after leaving the brooder?
13. At what temperature will eggs start to incubate? At what temperature should eggs being saved for hatching purposes be kept?
14. Prepare a chart, indicating the proper management of an incubator, so that the correct temperatures, the proper amount of moisture, and the necessary ventilation may be secured from the time the eggs are placed until the young chicks are removed.
15. At what temperatures should the brooder be when newly hatched chicks are placed in it? How rapidly should the temperature be lowered?
16. In what ways do eggs spoil, and how may spoiling be prevented?
17. Why are infertile eggs best for the market in warm weather? What are the characteristics of a first-class egg? How may the quality be determined?

## REFERENCES

- BROWN, E. Races of Domestic Poultry. Longmans, Green, and Company.
- LEWIS, H. R. Productive Poultry Husbandry. J. B. Lippincott Company.
- LIPPINCOTT, W. A. Poultry Production. Lea and Febiger.
- PURVIS, MILLER. Poultry Breeding, *Breeder's Gazette*.
- ROBINSON, J. H. Our Domestic Birds. Ginn and Company.
- ROBINSON, J. H. Principles and Practice of Poultry Culture. Ginn and Company.
- American Standard of Perfection. The American Poultry Association.
- Artificial Incubation and Brooding. The Reliable Poultry Journal Publishing Company.
- The Chick Book. The Reliable Poultry Journal Publishing Company.
- Ducks and Geese. The Reliable Poultry Journal Publishing Company.
- The Leghorns. The Reliable Poultry Journal Publishing Company.
- Natural and Artificial Brooding of Chickens, *Farmers' Bulletin 624*, United States Department of Agriculture, 1914.
- The Orpingtons. The Reliable Poultry Journal Publishing Company.
- The Plymouth Rocks. The Reliable Poultry Journal Publishing Company.
- Poultry Houses and Fixtures. Compiled and published by the Reliable Poultry Journal Publishing Company.
- The Rhode Island Reds. The Reliable Poultry Journal Publishing Company.
- Turkeys. The Reliable Poultry Journal Publishing Company.
- The Wyandottes. The Reliable Poultry Journal Publishing Company.



## CHAPTER XXXVI

### BUSINESS ASPECTS OF FARMING

Know that with a farm as with a man, however productive it may be, if it has the spending habit, not much will be left over. — CATO

#### I. FARM MANAGEMENT

**574. Cardinal principles.** In the preceding chapters more or less has been said about the business aspects of farm practices, but certain cardinal principles of farm management must be recognized. The farm business must be large enough to utilize profitably the different factors involved. Farm operations must be diversified. Farm labor must be constantly and productively employed. Farm products must be completely and intelligently utilized.

**575. Size of the farm.** Farm-management surveys show that there is a definite relation between the size of the business and the income; also that there is a maximum-size business beyond which profits decline in proportion to the increase. Considering only those farmers who carry on a general type of mixed farming, probably the minimum size of a profitable farm is about 100 acres with a total investment of from \$5000 to \$7000. The optimum size, or the size at which the business would be most profitable, is probably from 240 to 320 acres, with a total investment of from \$15,000 to \$25,000. A much larger business may be profitable in special cases, but more than average business ability is required to operate successfully the larger enterprises.

SIZE OF FARM AS RELATED TO PROFITS<sup>1</sup>

ACRES	LABOR INCOME <sup>2</sup> (DOLLARS)
30 or less . . . . .	168
31-60 . . . . .	254
61-100 . . . . .	373
101-150 . . . . .	436
151-200 . . . . .	635
Over 200 . . . . .	946

**576. Capital and profits.** Size of business may also be viewed from the standpoint of the total investment, as shown in the following table (also from the investigation cited above):

## RELATION OF CAPITAL TO PROFITS

CAPITAL (DOLLARS)	AVERAGE LABOR INCOME (DOLLARS)
2000 or less . . . . .	192
2001-4000 . . . . .	240
4001-6000 . . . . .	399
6001-8000 . . . . .	530
8001-10,000 . . . . .	639
10,001-15,000 . . . . .	870
Over 15,000 . . . . .	1164

Again, the labor income varies with the size of business. The smaller the business, the smaller the labor income; and the larger the business, up to the point shown in these tables, the larger the labor income.

**577. Why the small business does not pay.** Do small farms use man and horse labor and farm machinery to the same advantage as do the larger farms? The three following tables (also from the investigation cited above) answer this question.

<sup>1</sup> An Agricultural Survey, *Bulletin 295*, Cornell Experiment Station.

<sup>2</sup> By labor income is meant the money a farmer has left for his services after paying all running expenses of the farm and the interest on his investment. He has in addition to his labor income that which the farm supplies toward his living.

A. THE SIZE OF THE FARM AS RELATED TO THE EFFICIENCY  
OF MAN LABOR

SIZE OF FARM (ACRES)	ACRES FARMED WITH \$100 WORTH OF LABOR
30 or less . . . . .	5
31-60 . . . . .	12
61-100 . . . . .	18
101-150 . . . . .	22
151-200 . . . . .	26
Over 200 . . . . .	30

B. THE SIZE OF THE FARM AS RELATED TO THE EFFICIENCY  
OF HORSE LABOR

SIZE OF FARM (ACRES)	ACRES PER HORSE
30 or less . . . . .	15
31-60 . . . . .	21
61-100 . . . . .	30
101-150 . . . . .	37
151-200 . . . . .	41
Over 200 . . . . .	<u>49</u>
Average . . . . .	33

C. SIZE OF FARM AS RELATED TO EFFICIENT USE OF  
MACHINERY AND TOOLS

SIZE OF FARM (ACRES)	ACRES FARMED WITH \$100 WORTH OF MACHINERY AND TOOLS
30 or less . . . . .	17
31-60 . . . . .	20
61-100 . . . . .	24
101-150 . . . . .	25
151-200 . . . . .	30
Over 200 . . . . .	<u>29</u>
Average . . . . .	25

The first table shows that on the smallest farm \$100 worth of man labor farmed about 5 acres, while on the largest farms 6 times as much land is farmed with the same labor outlay. The labor was utilized 6 times more efficiently on the 200-acre farm than on the 5-acre farm. The second table shows that the horse on the small farm will do the work for 15 acres, while on the

large farm it will do the work for more than 3 times as many acres. The last table shows that \$100 worth of machinery served only 17 acres of land on the smallest farm, while on the largest farms it served nearly double this area. The farm business must be of such a size as to utilize man and horse labor and machinery to the best advantage. On the small farm dead investment in the case of machinery and the nonemployment or, at least, lack of profitable employment of labor is clearly revealed by the results of this survey.

It should not be inferred that only the large farm will pay. The man with small capital may own a small farm and rent additional land to good advantage. Where rentals are not excessive, it is good business to rent land.

**578. Farm operations should be diversified.** If as much as 60 per cent of the income of a farm is derived from the sale of hay and grain, it should be classed as a hay and grain farm; if from cotton, it should be classed as a cotton farm. The type of farming is also classified in other ways, such as extensive and intensive—according to whether farm operations are specialized or diversified.

Specialized farming is particularly adapted to large areas of cheap land or to small areas of high-priced land near a city. It is not well adapted to the average farm, more or less remote from market. Specialized farming, while often highly profitable, always carries the maximum risk as regards weather conditions and dangers from insect pests and plant diseases.

Diversified farming is better adapted to general conditions. It is important, however, to avoid too great a diversity. Thus, it would be unwise to grow on a 160-acre farm 40 acres of tobacco, 40 acres of corn, and 40 acres of cotton, because these crops leave the ground unprotected during the winter; they compete for labor by requiring cultivation at the same time, and they do not distribute the labor throughout the year. The labor requirement for such a series of crops would be very high from March until late fall, and little or nothing for the rest of the year. Such competing crops would not help solve the labor

problem. On the other hand, let the three 40-acre fields be grown in rotation in corn, in oats or wheat, and in clover. With such a rotation one man, with a little help for a few days at harvest, could farm the 120 acres. Such a rotation would be noncompeting as to labor and would assist in maintaining the fertility of the soil. In the same way farm stock may be conflicting or may work well together. Beef cattle and hogs, dairy cattle and hogs, or sheep and hogs combine well, while beef cattle and dairy cattle conflict. Some kinds of live stock combine well with certain crops, while others are in competition. For instance, dairy stock do not combine well with large areas of grain or hay, while beef cattle and hogs fit admirably into such a system, because they require little attention in summer when the crops require the maximum labor, and the stock gives profitable employment in winter. Therefore proper farm diversification avoids crops and stock which seriously compete and secures a combination which is adapted to the markets, soil, and climate.

**579. The distribution of farm labor.** The farm system should be planned so that the labor required will be evenly distributed throughout the year. Farm labor may be divided into three classes: maintenance labor, crop labor, and other productive labor. Maintenance labor, such as the regular chores, cutting weeds, and painting, brings no direct return and should be reduced to the smallest amount consistent with the proper upkeep of stock, machinery, and business.

Crop labor has to do with growing crops from the time spring work begins until the crop is sold. Although crop labor cannot run throughout the year, the system of cropping should keep the labor demand as uniform and as well balanced as possible during the crop season. If there is conflict between the best use of crop labor and a satisfactory cropping system, the crop-labor requirements should be readjusted.

Other productive labor includes all work on stock kept for profit (such as beef cattle, dairy cattle, sheep, hogs, and poultry), also special labor expended on crops after all necessary labor for their production and marketing has been performed. It includes



work in a maple grove, clearing land, marketing timber, and any other labor that adds to the value of the product concerned. When crop labor declines, labor on stock, on the preparation of seed, or on some other enterprise that brings a return should be increased. In reality the employment of labor on enterprises other than crop work often returns the greatest net profit of all labor on the farm. It is also the solution of a large part of farm-labor troubles, for it makes year-round work for farm hands, or steady employment at profitable operations.

The maintenance labor is fairly uniform throughout the year. The crop labor shows great variations. It runs high during March, June, and July, declines in August, rises again in October and November on account of the corn harvest, and runs low for the rest of the year. The vital point is to provide other productive labor, for it is used to level up the labor requirement for the year.

In some typical farms which were studied three men were required for three months, two men for two months, and during the remainder of the year there was scarcely enough work to keep the farmer himself busy.

**580. Horse labor.** The profitable employment of horse labor on the farm is as important as the proper use of man labor. The average farm horse works only about three and a half hours a day,<sup>1</sup> while the city horse works from eight to ten hours a day. Thus the farmer is losing from five to seven hours' labor each day on the horses he keeps. Estimating horse labor at five cents an hour and counting eight hours a full day, the annual loss sustained through the idleness of the horses on the average one-hundred-and-sixty-acre farm is over four hundred dollars.

One solution of the horse-labor problem is that already pointed out for man labor. Another solution is to keep the kind of work stock that will increase in value (such as young stock, or mares that raise colts while they work). Often a study of the horse-labor situation will show that the number of work horses can be reduced by a readjustment of the cropping system.

<sup>1</sup> The Distribution of Farm Labor, *Bulletin 6*, University of Missouri.

**581. Utilization of farm products.** At present the American farmer grows his crops and stock to better advantage than he utilizes them. Too much material goes to waste, and the road from the farm to the kitchen of the consumer is too long and involves too many people. On every farm enough live stock should be kept to utilize the coarser materials that have no market value. The products of the farm should be standardized by the farmer himself and should not require the services of a number of people at central markets to sort, pack, and otherwise prepare them for consumption. The farmers of Denmark took the egg business of London from the Irish farmer by furnishing only clean fresh eggs of standard size and quality. The apple growers of the Northwest have found a ready sale for their products at the highest market price because the stamp on each box is a guaranty of the standard quality of the contents. The whole question of the utilization of farm products concerns itself most intimately with the business side of farming and is more a work of the head than of the hand.

## II. FARM ACCOUNTS

**582. Keeping accounts.** The farmer should be able to tell at the end of the year what his gain or loss has been and which departments of his business have made or lost money. When the things are happening which the farmer should record in his accounts, he is often too busy to record them. When he has leisure, he has forgotten the details. A system of bookkeeping which is adapted to the average farmer must be simple.

**583. The inventory.** An inventory should be taken at the beginning of the farm year. The farmer should list everything he possesses, including real estate, live stock, equipment, supplies, bills receivable or money owed him (whether as notes or as open accounts), and cash on hand. After all of these items are listed and conservative values have been placed on each item, add the values of everything except bills payable, which will give the total investment in business. By subtracting bills payable from this total investment the net worth of the business is shown.

Another inventory should be taken at the close of the year. By placing the two inventories side by side as shown in Table I, a comparison of the net worth at the beginning and at the close of the year's business can be made. The amount of gain or loss does not tell the whole story. It is more important to know where the gain or loss has occurred. The inventory may show a gain of \$500 in the value of hogs, but if this increase has cost \$550 — a fact which the inventories cannot show — it does not represent gain but loss. To determine which department made money and which lost money it is necessary to carry ledger accounts for the various parts of the business. Table II shows a ledger account properly opened, with the items entered for the year, and closed at the end of the year.

**584. What accounts to keep.** Accounts should be kept with those parts of the business which are of the greatest importance. By keeping ledger accounts with the principal classes of live stock, and with the more important crops, the sources of the principal gains or losses will be revealed. The remainder of the receipts and expenses may be included in a general-expense account. If it is desired to find out what has been paid for labor, for family living, or for any other particular expense, the general-expense account may be divided so as to show these facts.

The crop and stock accounts take care of the productive enterprises on the farm, and the general-expense account will take care of the heavy expenses, like labor expenses, family living, and the purchase of feeds and supplies. If the business is conducted entirely on a cash basis, these accounts will make the work complete. If the farmer is buying and selling on account, he will need to carry additional accounts of bills payable and bills receivable.

**585. How to keep accounts.** The values as shown by the inventory should be entered in the various accounts, and in all these, with one exception, this value should be placed on the left-hand, or expense, side of the account. This exception is in bills payable. The expenses of live stock should include all cash outlay for additional animals and for veterinary fees, also the

value of labor used in caring for this stock and of the feed used from the crops grown on the farm. Each year's account should bear its proportion of taxes, insurance, and interest on investment. The receipts side of the live-stock account will include the amount received for animals or animal products sold and the value of the labor expended on crops, seed, and fertilizers used, and, at the end of the year, its proportionate part of the taxes, interest paid on the amount, and the depreciation on tools. On the receipt side should appear the value of the crops harvested.

The general expense account would carry all other expenses of the farm. Perhaps, at the beginning, a general crop account, a general live-stock account, and a general expense account are all that should be attempted.

#### INVENTORY SUMMARY

TABLE I. This table shows the proper method of summarizing a farm inventory to show the net investment.

	RESOURCES	LIABILITIES
Horses	\$1895.00	
Cattle	3880.00	
Hogs	250.00	
Sheep	415.50	
Poultry	149.85	
Equipment	1564.00	
Household equipment and supplies	750.00	
Feed	509.17	
Seed	108.50	
Miscellaneous supplies	194.05	
Real estate	40,500.00	
Wheat sown last fall (labor and seed)	143.16	
Bills receivable	569.00	
Bills payable		\$6431.35
Cash	337.19	
Proprietorship (net worth)		44,834.07
	\$51,265.42	\$51,265.42

TABLE II. This table illustrates the manner of comparing inventories from year to year.

	INVENTORY 1912	INVENTORY 1913
Horses	\$1895.00	\$1775.00
Cattle	3880.00	3910.00
Hogs	250.00	220.00
Sheep	415.50	362.00
Poultry	149.85	159.50
Equipment	1564.00	1593.00
Household equipment and supplies	750.00	852.00
Feed	509.17	669.86
Seed	108.50	124.75
Repair supplies	194.05	127.75
Real estate	40,500.00	40,500.00
Wheat crop sown last fall	143.16	
Bills receivable	569.00	46.95
Cash	337.19	707.66
Total resources	\$51,265.42	\$51,048.47
Less bills payable	6431.35	4502.01
Present worth	\$44,834.07	\$46,546.46
Gain	1712.39	
	\$46,546.46	\$46,546.46

The difference between the inventory values for the two years represents the gross gain or loss for the year either because of the increase or decrease in quantity, or because of the rise or fall in price. Such an inventory is of no value unless it gives the farmer a more definite idea of his business than he can form from his general knowledge of the situation. Therefore, in making the inventory every care should be taken to place a reasonable valuation on the property. By estimating the property too high, the inventory will mislead the farmer, and by placing the value too low, injustice will be done the business. It is always safer to fix an average value rather than to use the fluctuating value at the date on which the inventory is made.

TABLE III. Hog account, showing the most convenient form of ledger page; the correct method of opening the account, entering the items, and closing the account for the year. (Note the position of inventories at the beginning and close of year; also that the account is opened again for another year.)

## HOGS

Month		\$	¢	Month	\$	¢
1913	Mar. 1	Inventory	250			
	Apr. 1	Feed for March	19	60		
		Labor for March (33 hrs.)	4	62		
	Apr. 17	Veterinary expenses	3	75		
	Apr. 29	Bought boar pig	24			
	May 1	Feed for April	26	75		
		Labor for April (25 hrs.)	3	50		
	June 1	Feed for May	14	20		
		Labor for May (16 hrs.)	2	24		
		Feed for remainder of year	267	80		
		Labor for remainder of year	31	25		
1914	Mar. 1	Tax charge	2	35		
		Int. on investment @ 5%	12	50		
		Balance (gain)	335	28		
			1000	04		
	Mar. 1	Inventory	220			
					1000	04

This year's hog business showed a profit of \$335.28. A similar account with cattle, corn or cotton, and the other principal sources of income will show from what sources the profits of the year came, and, of greater importance, they will show what parts, if any, of the farm business lost money. Locating the leak is the first step toward stopping it.

## QUESTIONS AND PROBLEMS

1. What is shown to be the relation between the size of a farm and the labor income?
2. What is the relation of cash invested to profit in farming?
3. What is the relation between the size of farm and the efficiency of man labor on the farm?
4. What is the relation between the size of farm and the efficiency of horse labor on the farm?
5. What is the relation between size of farm and the efficiency of the use of tools and machinery?
6. What is meant by diversified farming? extensive farming? intensive farming?
7. What are the relative advantages of diversified farming and specialized farming?
8. How may the farm system be so planned that the labor required will be evenly distributed throughout the year?
9. What is the annual loss sustained through the nonuse of horses on the average quarter section of land?
10. What is necessary in order to utilize profitably all the products of the farm?
11. Give some good examples of standardization of farm products.
12. What is an inventory? How and when should it be taken?
13. What is meant by "bills receivable"? What should the bills-receivable account show at the end of the year?
14. What is meant by "bills payable"? What should the bills-payable account show at the end of the year?
15. What ledger accounts should a farmer keep? Why?
16. How may the farmer ascertain which departments of his business have made him money and which have not?

## EXERCISES

1. Make an inventory of some farm near the school, using Table I as a model.
2. Have each student open a ledger showing the different farm accounts, such as Bills Receivable, Bills Payable, Hogs, Horses, Cattle, General Expenses, Cash, etc.
3. A farmer buys a horse for \$175, paying for it in cash. To which accounts should this go? If the farmer should sell the horse

for \$200, what entries should be made and what accounts are affected? If the farmer receives a note in payment for the horse, to what account should the note go?

4. Make out a cattle-ledger account for the following: On June 30 Mr. Jones has \$2500 worth of cattle on hand; on July 15 he buys 10 head of steers for \$400; on August 10 he buys 18 calves at \$15 each; on September 10 he pays out \$6 for veterinary service; on December 2 one of his steers, valued at \$60, dies; on February 2 he sells 15 steers for \$800; on March 1 he sells 12 calves for \$175. During the year he pays out for labor on his cattle, \$100; for feed, \$1000; for taxes, \$20; insurance, \$15; interest, \$60. One year from June 1 his stock are worth \$4100. Has he gained or lost, and how much?

#### REFERENCES

- BAILEY, L. H. *The State and the Farmer*. The Macmillan Company.  
BOSS, ANDREW. *Farm Management*. Lyons and Carnahan.  
CATO, MARCUS PORCIUS. *Roman Farm Management*. The Macmillan Company.  
DOANE, D. H. *Sheep Feeding and Farm Management*. Ginn and Company.  
POWELL, GEORGE H. *Coöperation in Agriculture*. The Macmillan Company.  
SULLIVAN, J. W. *Markets for People*. The Macmillan Company.  
WARREN, G. F. *Farm Management*. The Macmillan Company.



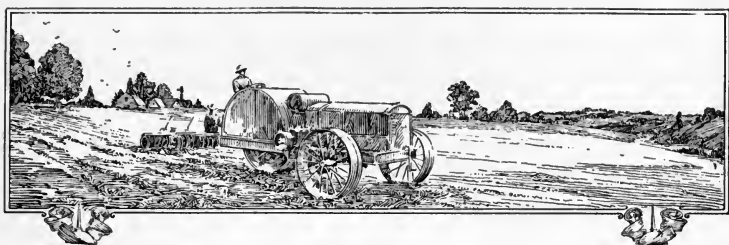

## CHAPTER XXXVII

### MECHANICAL POWER FOR THE FARM

**586. Introductory.** Throughout the preceding chapters discussions and illustrations of farm machinery have been presented in connection with the practices with which the various appliances belong. There are many things of importance relating to farm machinery and mechanical power which cannot be included in a one-volume book. However, a few of the most important features of mechanical power are presented in this chapter. The productiveness of the farm, as well as that of the man who works it, is being greatly increased by the use of artificial mechanical power where the farm is large enough to warrant the purchase of motors for the use of such power. Mechanical power can be produced by harnessing moving winds and falling waters, or by utilizing the heat from fuel.

**587. The windmill.** In localities where the wind is abundant and but little power is needed, the windmill is the most desirable and the cheapest form of motor for developing mechanical power. The main use of a windmill is to pump water for household purposes and for live stock. The power of the average windmill is also sufficient for driving grindstones, small churns, and other machines requiring little power.

**588. The water motor.** Falling water to produce power can be obtained by collecting water in dams or tanks, or by utilizing the energy in natural waterfalls (Fig. 224). The amount of power developed by a water motor depends upon the amount

of water available as well as upon the *head*, or distance through which the water is allowed to fall. The reliability of this form of power is affected by drought, by floods, and by ice in the water supply.

**589. Fuel as a source of power.** The greatest source of mechanical power is fuel. The fuels most commonly used for power generation are coal, wood, petroleum oil, and natural gas. These fuels, when burned, give up heat which is utilized in changing water into steam or in heating the air. The steam or the air is then allowed to expand in a motor cylinder, pushing against the piston and thus doing the work.

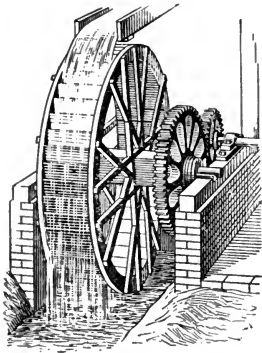

FIG. 224. A simple type of water motor

The water striking the vanes, or cups, produces rotation of the wheel. Such a water motor can be constructed by inserting between two wooden disks a number of buckets made like V-shaped troughs, and putting a wooden or metal shaft at the center of the disks, for the purpose of transmitting the power developed by the rotation of the wheel

**590. The steam power plant.** To produce mechanical power by means of a steam engine (Fig. 225), the fuel must be burned in a furnace outside the engine cylinder. The furnace is a chamber arranged with a grate, if coal or wood is burned, and with burners, when oil or gas is used. This furnace must be connected with a chimney, to produce draft and carry off the gases.

The heat developed by the burning of the fuel in the furnace is utilized by the changing of water into steam in a closed cylindrical vessel called a boiler.

In connection with modern farming the steam power plant is used mainly on traction engines.

**591. The oil engine on the farm.** Of all farm motors, the oil engine using gasoline or the heavier oils has the greatest field of usefulness. Such an engine is portable and can be used for various farm and household purposes, such as pumping water and driving cream separators, churns, pumps, ice-cream

freezers, washing machines, feed grinders, ensilage cutters, corn shellers, hay presses, binders, spraying machines, wood saws, cement mixers, rock crushers, and grindstones, and for many other uses about the dairy barn and the farmhouse. By connecting an oil engine to an electric dynamo, electricity can be generated for farm lighting. The oil engine has also been

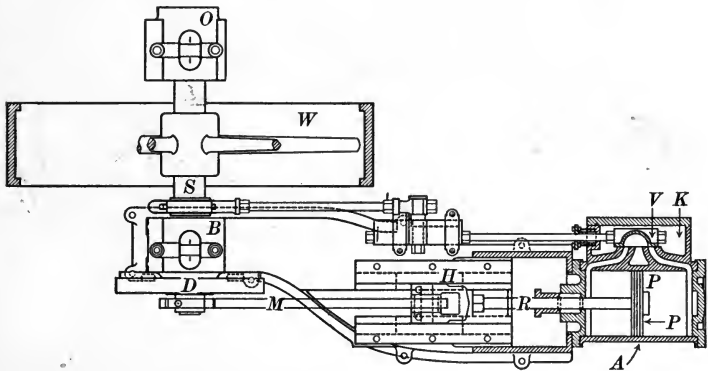

FIG. 225. Fundamental parts of a steam engine

Steam pipes convey the steam from the boiler (not here shown) to the engine. The steam from the boiler enters the steam chest *K* and is admitted alternately to either end of the cylinder *A* by the valve *V*. The steam entering the cylinder *A* pushes on the piston *P*. The motion of the piston is transmitted through the piston rod *R* to the crosshead *H*, and through the connecting rod *M* to the crank disk *D*, which is keyed to the crank shaft *S*. The crank shaft is connected directly or by means of belts to the machines to be driven; it is supported on two bearings, *B* and *O*, and carries the flywheel *W*, the function of which is to make the speed of the engine more uniform

used with great success for propelling automobiles, trucks, and traction engines, and its use is increasing.

**592. Action of gas engines and oil engines.** The gas engine and the oil engine differ from the steam engine in that the entire transformation of the heat energy of the fuel into work takes place within the engine cylinder. The fuel in the case of the gas engine may be natural gas or some form of artificial gas manufactured from coal or oil. The fuels for oil engines are gasoline, kerosene, and crude petroleum. Alcohol has also been

used successfully as a fuel for this type of engine, but it is too expensive in comparison with gasoline and kerosene.

In order that the greatest energy of the fuel may be secured in gas engines and oil engines, the fuel must be mixed with

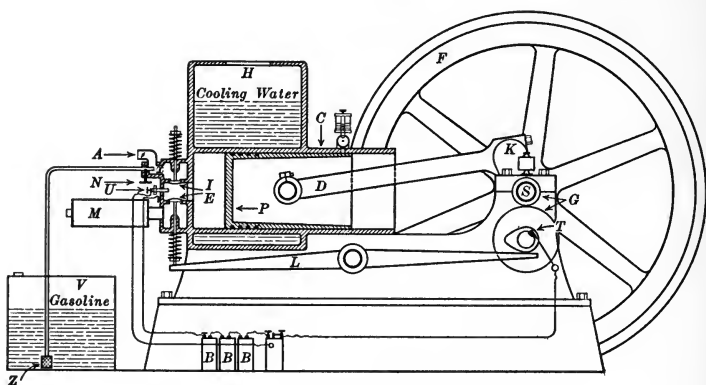

FIG. 226. Essential parts of a gasoline engine

The gasoline from the tank *V* passes through the strainer *Z*, where the impurities are deposited, then through the gasoline-regulating valve *N* to the mixer, or carburetor *x*. The air through the air-regulating valve *A* enters the same carburetor and is thoroughly mixed with the gasoline. The mixture of air and gasoline enters the engine cylinder *C* through the inlet valve *I* as the piston *P* moves to the right on the outward stroke. Under the influence of the flywheel *F*, the piston returns, compressing the mixture between the piston and the closed end of the cylinder, with all the valves closed. Just before this return stroke of the piston is completed the mixture is ignited by an electric spark at the spark plug *U* and rapid burning, or explosion, of the mixture takes place. The high pressure developed by this explosion drives the piston forward on its power stroke, all valves still remaining closed. Near the end of the power stroke, the exhaust valve *E* opens and the "burned gases" begin to rush out. The return of the piston clears the cylinder of the burned gases. The sliding motion of the piston is changed into a rotary motion at the shaft *S* by the connecting rod *D* and the crank *K*. The shaft, while driving the machinery to which it is connected, also gives motion through the two gears *G*, to the exhaust-valve lift rod *L*. The spark for igniting the mixture is produced at the spark plug by the electrical batteries *B*, the timer *T* completing the electric circuit at the proper time

air in certain definite proportions before it enters the engine cylinder. This can be accomplished only when the fuel is in the gaseous state. Thus, the oil engine differs from the gas engine in that it requires a device (called a carburetor) for converting the liquid oil fuel into a gas before it can be used. Since

the ignition of the explosive mixture heats the cylinder, some method of cooling the cylinder walls must be used. Cooling is necessary to facilitate oiling, to prevent the moving parts from being heated and twisted, and to avoid the ignition of the explosive mixture at the wrong time by the heat of the cylinder walls. One method of cooling is to jacket the cylinder so as to allow water to pass through the jacketed space. In Fig. 226 the water contained in the hopper *H* is heated by contact with the hot cylinder walls, rises, and is replaced by cooler water. Some small engines are air-cooled.

The exhaust muffler *M* is to decrease the noise made by the burned gases as they leave the engine cylinder. Four complete strokes of the piston, or two revolutions, are essential for carrying out the various processes in the type of gas engine shown in the figure. The name four-cycle, or four-stroke, engine is given to this form of gas engine. Some engines, called two-cycle engines, carry out the above operations in two strokes, but the four-cycle type of engine is usually preferred on account of its greater reliability and better fuel economy.

**593. Selecting and installing an oil engine.** An oil engine should be large enough to do the required work, as it will stand little overload. On the other hand, an engine too large for the work it has to do will give poor fuel economy.

A two-horse-power or three-horse-power engine is usually large enough to do the work about the house, dairy, and barn. For feed grinding and for threshing and wood sawing a five-horse-power engine, or even a larger size, may be needed.

Engines of five horse power and larger should be operated on kerosene or on a still heavier petroleum fuel, as the cost of gasoline is high in comparison with these fuels. Most manufacturers build engines which are well adapted to the cheaper fuels as well as to gasoline.

It is best to locate a gasoline engine in a separate room. The room should be well lighted and ventilated, free from dirt and dust, and should be large enough so that there will be sufficient space for easy access to any part of the engine.

In using gasoline engines and oil engines, the fuel tank should be located outside of the building, preferably underground. In any case the tank must be lower than the pipe to which it is connected in the engine room, so as to prevent flooding the engine.

The foundation for a gas or an oil engine should be as solid as possible. If the engine is to be set on a wood floor, the timbers should be laid on or under the floor and at right angles to the joists. If the engine must be located over another room, it is best to place it in a corner and near the wall.

**594. The electric motor on the farm.** If electricity can be bought at a low price, the electric motor is very well suited for some of the farm work. It is not so portable as the gasoline engine in any but the very small sizes, but a small motor requires no special foundation, is clean and easily started, and requires less care than the gasoline engine.

For farms of the average size, which do not have the advantage of cheap power from a near-by transmission system, private electric-lighting plants driven by gasoline engines are becoming quite common.

#### QUESTIONS AND PROBLEMS

1. What is the importance of artificial mechanical power on the farm?
2. How may mechanical power be produced on the farm?
3. Discuss the use of the windmill as a means of providing mechanical power.
4. Where may water motors be successfully used?
5. Describe the construction of a water motor.
6. What fuels are most commonly used for mechanical power?
7. What is the relation of the boiler furnace to the engine cylinder in generating power by means of a steam-power plant?
8. Explain briefly the principle of the steam engine. Make a sketch to illustrate your explanation.
9. Explain briefly the principles of the gas and the oil engines. Illustrate your explanation by a sketch.
10. What cautions should be used in selecting and installing an oil engine?

11. Compare the electric motor with the gasoline engine as a means of producing mechanical power.
12. With a particular farm plant as an illustration, make a plan for one type of engine, showing its location, its construction, and the operations with which it is connected.

#### REFERENCES

- ALLEN, J. R., and BURSLEY, J. A. Heat Engines. McGraw-Hill Book Company.
- DAVIDSON, J. B., and CHASE, L. W. Farm Machinery and Farm Motors. Orange Judd Company.
- HIRSHFELD, C. F., and ULBRICHT, T. C. Farm Gas Engines. J. Wiley and Sons.
- LUCKE, C. E. Power. The Columbia University Press.
- POTTER, A. A. Farm Motors. McGraw-Hill Book Company.
- Comparative Fuel Values of Gasoline and Denatured Alcohol in Internal-Combustion Engines, *Bulletin 43*, Bureau of Mines, United States Department of Interior.
- The Use of Alcohol and Gasoline in Farm Engines, *Farmers' Bulletin 277*, United States Department of Agriculture.





# APPENDIX A

## SINGLE-PLATE SCORE CARD — APPLES

VARIETY	FORM 15 POINTS	SIZE 15 POINTS	COLOR 20 POINTS	UNIFORM- ITY 20 POINTS	FREEDOM FROM BLEMISHES 30 POINTS	TOTAL 100 POINTS

### *Explanation of Values*

**Form.** In all cases "form" refers to the normal type of the variety; region of growth considered.

**Size.** The most acceptable commercial size for the variety should be the ideal. This should be somewhat above the average size for the variety in regions where it is well grown. Extremely large size should be discouraged.

**Color.** In red, blushed, or striped apples, high, clear color is desirable. In typically green or uncolored fruits, a blush shall not be considered either favorably or otherwise.

**Uniformity.** This factor infers that all fruits shall be uniform in form, size, and color.

**Quality.** This factor includes texture, juiciness, flavor, aroma, and any other characters that may give pleasure to the palate, and counts 25 points. In judging plate exhibits, the fruit is not cut or tasted, and therefore quality is omitted from the score card. When judging apples in bulk, such as in packages, boxes, or barrels, quality should be included.

# APPENDIX B

## SCORE CARD FOR INDIVIDUAL EARS OF CORN

SCALE OF POINTS	POS- SIBLE SCORE	POINTS DEFICIENT	
		Student's Score	Corrected Score
<p>1. <b>Variety type.</b> The ear should conform to the general type of the variety to which it belongs, in respect to size and shape of ear, color of kernels and cob, and width, thickness, depth, shape, spacing, and indentation of kernels. When variety type is not known, give perfect score on this point . . . . .</p>	5		
<p>2. <b>Maturity and soundness.</b> The ear should be well-matured, dry, firm when twisted, and of good weight for its size and condition. Sappiness, moldiness at the crowns of the kernels and at the cob, looseness of corn on cob, chaffiness, adherence of tip caps to cob and of considerable chaff to the tips, are all indications of immaturity. Decayed, mouse-eaten, and insect-injured kernels are unsound and also indicate a poor seed condition . . . . .</p>	15		
<p>3. <b>Purity.</b> (1) <i>Of kernels.</i> Kernels should be free from mixture with corn of other colors. Mixture in yellow corn is shown on the caps of the kernels and in white corn usually on the sides. Deduct one-half point for each kernel distinctly showing undesired color. If in competition, ten or more mixed kernels should bar the ear. (2) <i>Of cob.</i> Cobs in yellow corn usually should be red, the shade of red desired varying with variety; and in white corn, white. For pink cobs, cut according to shade. A cob of distinctly undesired color, unless a variety characteristic, should be given a score of zero, and if in competition, the ear should be barred . . . . .</p>	5		
<p>4. <b>Shape of ear.</b> In general a well-shaped ear should (1) be nearly cylindrical; (2) have straight rows running directly from butt to tip; (3) be full and strong in the middle portion; (4) not be flattened. Such an ear will shell a high percentage of uniformly shaped kernels . . . . .</p>	10		
<p>5. <b>Size and shape of kernels.</b> Size of kernels includes the depth, width, and thickness. For average corn-belt conditions a medium depth of kernel usually produces the largest yield of mature corn. The width, thickness, and shape of kernels vary with varieties. As a general rule, however, they should be keystone-shaped, permitting the edges of the kernels to touch from crown to tip. As to thickness, the kernels should number about six to the inch in the row . . . . .</p>	10		
<p>6. <b>Uniformity of kernels.</b> The kernels should be uniform in depth, width, thickness, and shape throughout the ear. Irregular kernels are objectionable . . . . .</p>	5		
<p>7. <b>Size and condition of germs.</b> The germs should be long, wide, thick, smooth, and bright; not shriveled, blistered, shrunken, moldy, or discolored. The embryo proper should show a fresh, oily, and live appearance and be yellowish-white in color . . . . .</p>	10		

SCORE CARD FOR INDIVIDUAL EARS OF CORN (CONTINUED)

SCALE OF POINTS	POS- SIBLE SCORE	POINTS DEFICIENT	
		Student's Score	Corrected Score
8. <b>Butt.</b> The butt should carry out the circumference of the ear uniformly and not be pinched, enlarged, expanded, or flattened. It should be well rounded out with straight rows of regular kernels having nearly the same depth, width, thickness, and shape as the body kernels. The grains on the butt should be uniformly arranged around a medium-sized, cup-shaped cavity . . . . .	5		
9. <b>Tip.</b> The tip should be covered to the end of the cob with kernels arranged in straight rows and having nearly the same size and shape as the body kernels. Shallow, narrow, irregular, glistening, and shot-shaped kernels are objectionable . . . . .	5		
10. <b>Space between rows and kernels.</b> Large, open spaces between the rows either at the crowns or the tips of grains or between the kernels in the same row are objectionable. There should be only enough space to permit satisfactory drying of the ear. Too close spacing is also objectionable . . . . .	5		
11. <b>Proportion of grain to cob.</b> The proportion of grain to cob differs with varieties and with the latitude under which grown. A reasonably good seed ear should shell from 85 to 87 per cent. The occurrence of one or more of the following factors may indicate a low proportion of grain to cob: (1) large cob; (2) moist and heavy cob; (3) shallow kernels; (4) wide space between rows either at the crowns or the tips of the kernels in the same row; (5) butts and tips much exposed; (6) butt and tip kernels extremely shallow . . . . .	5		

# APPENDIX C

## SCORE CARD—DRAFT HORSES

SCALE OF POINTS	POS- SIBLE SCORE	POINTS DEFICIENT	
		Student's Score	Corrected Score
Age, estimated . . . . . yr., actual . . . . . yr.			
<b>GENERAL APPEARANCE — 26 Points</b>			
Height, estimated . . . . . hands; actual . . . . . hands	1		
Weight, over 1600 lb. in good condition; estimated . . . . . lb., score according to age . . . . .	5		
Form, broad, massive, symmetrical, blocky . . . . .	4		
Quality, refined; bone clean, large, strong; tendons clean, defined, prominent; skin and hair fine; "feather," if present, silky . . . . .	4		
Action, energetic, straight, true, elastic; walk, stride long, quick, regular; trot free, balanced, rapid . . . . .	10		
Temperament, energetic; disposition good . . . . .	1		
Style, stylish and graceful carriage . . . . .	1		
<b>HEAD AND NECK — 8 Points</b>			
Head, proportionate size, clean-cut, well-carried; profile straight . . . . .	1		
Muzzle, neat; nostrils large, flexible; lips thin, even, firm . . . . .	1		
Eyes, full, bright, clear, large, same color . . . . .	1		
Forehead, broad, full . . . . .	1		
Ears, medium size, tapering, well-carried, alert . . . . .	1		
Lower jaw, angles wide, space clean . . . . .	1		
Neck, medium length, well-musclcd, arched; throatlatch fine, windpipe large . . . . .	2		
<b>FORE QUARTERS — 23 Points</b>			
Shoulders, long, moderately sloping, heavily and smoothly musclcd, extending into back . . . . .	3		
Arms, short, heavily musclcd, thrown back, well-set . . . . .	1		
Forearm, long, wide, clean, heavily musclcd . . . . .	2		
Knees, straight, wide, deep, strong, clean, well-supported . . . . .	2		
Cannons, short, wide, clean; tendons large, clean, and well-defined, set back . . . . .	2		
Fetlocks, wide, straight, strong, clean . . . . .	1		
Pasterns, moderate slope and length, strong, clean . . . . .	3		

## SCORE CARD — DRAFT HORSES (CONTINUED)

SCALE OF POINTS	POS- SIBLE SCORE	POINTS DEFICIENT	
		Student's Score	Corrected Score
<b>Feet</b> , large, even size, sound; horn dense, waxy; soles concave; bars strong, full; frog large, elastic; heels wide, strongly supported . . . . .	7		
<b>Legs</b> , viewed in front, a perpendicular line from the point of the shoulder should fall upon the center of the knee, cannon, pastern, and foot; from the side, a perpendicular line dropping from the center of the elbow joint should fall upon the center of the knee and pastern joints and the back of the hoof . . . . .	2		
<b>BODY — 10 Points</b>			
<b>Withers</b> , moderate height, smooth, extending well back . . . . .	1		
<b>Chest</b> , deep, breastbone low; girth large . . . . .	2		
<b>Ribs</b> , deep, well-sprung, closely ribbed to hip . . . . .	2		
<b>Back</b> , broad, short, strong, muscular . . . . .	2		
<b>Loin</b> , broad, short, heavily muscled . . . . .	2		
<b>Underline</b> , long, low; flanks well let down . . . . .	1		
<b>HIND QUARTERS — 33 Points</b>			
<b>Hips</b> , broad, smooth, level . . . . .	2		
<b>Croup</b> , long, wide, heavily muscled, not markedly drooping . . . . .	2		
<b>Tail</b> , attached high, well-carried . . . . .	1		
<b>Thighs</b> , deep, broad, heavily muscled . . . . .	2		
<b>Quarters</b> , deep, heavily muscled . . . . .	2		
<b>Stifles</b> , clean, strong . . . . .	2		
<b>Gaskins</b> (lower thighs), long, wide, heavily muscled . . . . .	2		
<b>Hocks</b> , large, strong, wide, deep, clean . . . . .	6		
<b>Cannons</b> , short, wide, clean; tendons large, clean, and well-defined, set back . . . . .	2		
<b>Fetlocks</b> , wide, straight, strong, clean . . . . .	1		
<b>Pasterns</b> , moderate slope and length, strong, clean . . . . .	2		
<b>Feet</b> , large, even size, sound; horn dense, waxy; soles concave; bars strong, full; frog large, elastic; heels wide, strongly supported . . . . .	6		
<b>Legs</b> , viewed from behind, a perpendicular line from the point of the buttock should fall upon the center of the hock, cannon, and foot; from the side a perpendicular line from the hip joint should fall upon the center of the foot and divide the gaskin in the middle; and a perpendicular line from the point of the buttock should run parallel with the line of the cannon . . . . .	3		
<b>Total</b> . . . . .	100		

# APPENDIX D

## SCORE CARD — LIGHT HORSES<sup>1</sup>

SCALE OF POINTS	POS- SIBLE SCORE	POINTS DEFICIENT	
		Student's Score	Corrected Score
Age, estimated . . . . . yr., actual . . . . . yr.			
<b>GENERAL APPEARANCE — 28 Points</b>			
Weight, estimated . . . . . lb.; actual . . . . . lb.			
Height, estimated . . . . . hands; actual . . . . . hands	2		
Form, symmetrical, smooth, stylish . . . . .	4		
Quality, refined; bone clean, fine; tendons clean, defined; hair and skin fine . . . . .	4		
Action, energetic, straight, true, elastic; walk, stride long, quick, regular; trot free, balanced, rapid . . . . .	15		
Temperament, active; disposition good; stylish carriage .	3		
<b>HEAD AND NECK — 8 Points</b>			
Head, proportionate size, clean-cut, well-carried; profile straight . . . . .	1		
Muzzle, neat; nostrils large, flexible; lips thin, even, firm .	1		
Eyes, full, bright, clear, large, same color . . . . .	1		
Forehead, broad, full . . . . .	1		
Ears, medium size, tapering, well-carried, alert . . . . .	1		
Lower jaw, angles medium wide, space clean . . . . .	1		
Neck, long, well-muscled, arched; throatlatch fine, clean; windpipe large . . . . .	2		
<b>FORE QUARTERS — 23 Points</b>			
Shoulder, long, sloping, smoothly muscled, extending into back . . . . .	3		
Arms, short, strongly muscled, thrown back, well-set . .	1		
Forearm, long, wide, clean, strongly muscled . . . . .	2		
Knees, straight, wide, deep, strong, clean, strongly supported . . . . .	2		
Cannons, short, wide, clean; tendons large, clean, and well- defined, set back . . . . .	2		
Fetlocks, wide, straight, strong, clean . . . . .	1		
Pasterns, long, sloping, strong, clean . . . . .	3		

<sup>1</sup> For saddle horses the light-horse score card should be used, including, under Action, the five gaits, viz.: walk, canter, rack, fox trot, and slow pace or running walk. For coach horses it should be remembered that high and stylish action are preferable to speed.

SCORE CARD — LIGHT HORSES (CONTINUED)

SCALE OF POINTS	POS- SIBLE SCORE	POINTS DEFICIENT	
		Student's Score	Corrected Score
<b>Feet</b> , medium and even size, sound; horn dense, waxy; soles concave; bars strong, full; frog large, elastic; heels wide, strongly supported . . . . .	6		
<b>Legs</b> , viewed in front, a perpendicular line from the point of the shoulder should fall upon the center of the knee, cannon, pastern, and foot; from the side, a perpendicular line dropping from the center of the elbow joint should fall upon the center of the knee and pastern joints and the back of the hoof . . . . .	3		
<b>BODY — 10 Points</b>			
<b>Withers</b> , moderate height, smooth, extending well back . . . . .	1		
<b>Chest</b> , deep, wide; breastbone low; girth large . . . . .	2		
<b>Ribs</b> , deep, well-sprung, closely ribbed to hip . . . . .	2		
<b>Back</b> , broad, short, strong, muscular . . . . .	2		
<b>Loins</b> , broad, short, strongly and smoothly muscled . . . . .	2		
<b>Underline</b> , long, low; flanks well let down . . . . .	1		
<b>HIND QUARTERS — 31 Points</b>			
<b>Hips</b> , broad, smooth, level . . . . .	2		
<b>Croup</b> , long, wide, muscular, not markedly drooping . . . . .	2		
<b>Tail</b> , attached high, well-carried . . . . .	1		
<b>Thighs</b> , deep, broad, strongly muscled . . . . .	2		
<b>Quarters</b> , deep, heavily muscled . . . . .	1		
<b>Stifles</b> , strong, clean, muscular . . . . .	2		
<b>Gaskins</b> (lower thighs), long, wide, strongly muscled . . . . .	2		
<b>Hocks</b> , large, strong, wide, deep, clean . . . . .	6		
<b>Cannons</b> , short, wide, clean; tendons large, clean, and well-defined, set back . . . . .	2		
<b>Fetlocks</b> , wide, straight, strong, clean . . . . .	1		
<b>Pasterns</b> , long, sloping, strong, clean . . . . .	3		
<b>Feet</b> , medium and even size, sound; horn dense, waxy; soles concave; bars strong, full; frog large, elastic; heels wide, strongly supported . . . . .	4		
<b>Legs</b> , viewed from behind, a perpendicular line from the point of the buttock should fall upon the center of the hock, cannon, and foot; from the side, a perpendicular line from the hip joints should fall upon the center of the foot and divide the gaskin in the middle; and a perpendicular line from the point of the buttock should run parallel with the line of the cannon . . . . .	3		
<b>Total</b> . . . . .	100		

# APPENDIX E

## SCORE CARD — MULES

SCALE OF POINTS	POS- SIBLE SCORE	POINTS DEFICIENT	
		Student's Score	Corrected Score
Age, estimated . . . . . yr., actual . . . . . yr.			
<b>GENERAL APPEARANCE — 26 Points</b>			
Height, 16 hands or over; estimated . . . . . actual . . . . .	3		
Weight, 1200 to 1600 lb. in good condition; estimated . . . . . lb., score according to age . . . . .	3		
Form, broad, massive, symmetrical, blocky . . . . .	4		
Quality, bone, clean, large, strong; tendons defined; skin and hair fine . . . . .	6		
Action, energetic, straight, true, elastic; walk, stride long, quick, regular; trot free, balanced, rapid . . . . .	8		
Temperament, active, good disposition; stylish carriage . . . . .	2		
<b>HEAD AND NECK — 9 Points</b>			
Head, proportionate size, clean-cut, well-carried; profile straight or slightly Roman-nosed . . . . .	1		
Muzzle, neat; nostrils large, flexible; lips thin, even, firm . . . . .	1		
Eyes, full, bright, clear, large, same color . . . . .	1		
Forehead, broad, full . . . . .	1		
Ears, large, tapering, fine texture, well-carried, alert . . . . .	2		
Lower jaw, angles wide, space clean . . . . .	1		
Neck, medium length, well-muscled, arched; throatlatch fine; windpipe large . . . . .	2		
<b>FORE QUARTERS — 22 Points</b>			
Shoulders, long, moderately sloping, heavily and smoothly muscled, extending into back . . . . .	2		
Arms, short, heavily muscled, thrown back, well-set . . . . .	1		
Forearm, long, wide, clean, heavily muscled . . . . .	2		
Knees, straight, wide, deep, strong, well-supported . . . . .	2		
Cannons, short, wide, clean; tendons large, clean, and well-defined, set back . . . . .	2		
Fetlocks, wide, straight, strong, clean . . . . .	1		
Pasterns, moderate slope and length, strong, clean . . . . .	3		
Feet, large, even size, sound; horn dense, waxy; soles concave; bars strong, full; frog large, elastic; heels wide and strongly supported . . . . .	6		
Legs, viewed in front, a perpendicular line from the point of the shoulder should fall upon the center of the knee, cannon, pastern, and foot; from the side, a perpendicular line dropping from the center of the elbow joint should fall upon the center of the knee and pastern joints and the back of the hoof . . . . .	3		



## SCORE CARD — MULES (CONTINUED)

SCALE OF POINTS	POS- SIBLE SCORE	POINTS DEFICIENT	
		Student's Score	Corrected Score
<b>BODY — 10 Points</b>			
Withers, moderate height, smooth, extending well back . . . . .	1		
Chest, deep, wide; breastbone low; girth large . . . . .	2		
Ribs, deep, well-sprung, closely ribbed to hip . . . . .	2		
Back, broad, short, strong, muscular . . . . .	2		
Loin, broad, short, heavily muscled . . . . .	2		
Underline, long, low; flank well let down . . . . .	1		
<b>HIND QUARTERS — 33 Points</b>			
Hips, broad, smooth, level . . . . .	2		
Croup, long, wide, heavily muscled, not markedly drooping	2		
Tail, attached high, well-carried . . . . .	1		
Thighs, deep, broad, strong, heavily muscled . . . . .	2		
Quarters, deep, heavily muscled . . . . .	2		
Stifles, strong, clean, muscular . . . . .	2		
Gaskins (lower thighs), long, wide, clean; tendons large, heavily muscled . . . . .	2		
Hocks, large, strong, wide, deep, clean . . . . .	7		
Cannons, short, wide, clean; tendons large, clean, and well- defined, set back . . . . .	2		
Fetlocks, wide, straight, strong, clean . . . . .	1		
Pasterns, moderate slope and length, strong, clean . . . . .	2		
Feet, large, even size, sound; horn dense, waxy; soles concave; bars strong, full; frog large, elastic; heels wide and strongly supported . . . . .	5		
Legs, viewed from behind, a perpendicular line from the point of the buttock should fall upon the center of the hock, cannon, and foot; from the side, a perpendicular line from the hip joint should fall upon the center of the foot and divide the gaskin in the middle; and a perpen- dicular line from the point of the buttock should run parallel with the line of the cannon . . . . .	3		
Total . . . . .	100		

# APPENDIX F

## SCORE CARD — DAIRY CATTLE

SCALE OF POINTS	POS- SIBLE SCORE	POINTS DEFICIENT	
		Student's Score	Corrected Score
<b>GENERAL APPEARANCE — 18 Points</b>			
Form, inclined to be wedge-shaped . . . . .	6		
Quality, hair fine, soft; skin mellow, loose, medium thick- ness; secretion yellow; bone clean, fine . . . . .	6		
Temperament, nervous, indicated by lean appearance when in milk . . . . .	6		
<b>HEAD AND NECK — 7 Points</b>			
Muzzle, clean cut; mouth large; nostrils large . . . . .	1		
Eyes, large, bright, full, mild . . . . .	1		
Face, lean, long; quiet expression . . . . .	1		
Forehead, broad . . . . .	1		
Ears, medium size, yellow inside, fine texture . . . . .	1		
Horns, fine texture, waxy . . . . .	1		
Neck, fine, medium length; throat clean; light dewlap . . . . .	1		
<b>FORE QUARTERS — 5 Points</b>			
Withers, lean, thin . . . . .	1		
Shoulders, light, oblique . . . . .	2		
Legs, straight, short; shank fine . . . . .	2		
<b>BODY — 26 Points</b>			
Chest, deep, low; girth large, with full foreflank . . . . .	10		
Barrel, ribs broad, long, wide apart; large stomach . . . . .	10		
Back, lean, straight, open-jointed . . . . .	2		
Loin, broad . . . . .	2		
Navel, large . . . . .	2		
<b>HIND QUARTERS — 44 Points</b>			
Hips, far apart, level . . . . .	2		
Rump, long, wide . . . . .	2		
Pin bones, high, wide apart . . . . .	1		
Tail, long, slim; fine hair in switch . . . . .	1		
Thighs, thin, long . . . . .	4		
Udder, long, attached high, and full behind, extending far in front and full, flexible; quarters even and free from fleshiness . . . . .	22		
Teats, large, evenly placed . . . . .	5		
Mammary veins, large, long, tortuous, branched, with double extension; large and numerous milk wells . . . . .	5		
Legs, straight; shank fine . . . . .	2		
Total . . . . .	100		

# APPENDIX G

## SCORE CARD—BEEF CATTLE

STANDARD OF EXCELLENCE	POS- SIBLE SCORE	POINTS DEFICIENT			
		Student's Score		Corrected Score	
		No. 1	No. 2	No. 1	No. 2
<b>Weight</b> , estimated . . . . . lb., according to age . . . . .	10				
<b>Form</b> , straight top line and underline; deep, broad, low-set; compact, symmetrical . . . . .	10				
<b>Quality</b> , hair fine; bone firm but strong; skin pliable; mellow, even covering of firm flesh, especially in region of valuable cuts; absence of ties and rolls . . . . .	10				
<b>Condition</b> , prime; flesh deep; evidence of finish especially marked in cod, at tail-head, flank, shoulder, and throat; absence of ties or rolls . . . . .	10				
<b>Head</b> , clean-cut, symmetrical; quiet expression; mouth and nostrils large, clear, and placid; face short; forehead broad, full; ears medium size, fine texture, erect . . . . .	5				
<b>Neck</b> , thick, short, tapering neatly from shoulder to head; throat clean . . . . .	2				
<b>Shoulder vein</b> , full . . . . .	2				
<b>Shoulder</b> , well covered with flesh; compact . . . . .	3				
<b>Brisket</b> , full, broad but not too prominent; breast wide . . . . .	1				
<b>Dewlap</b> , skin not loose and drooping . . . . .	1				
<b>Chest</b> , deep, wide, full . . . . .	1				
<b>Crops</b> , full, thick, broad . . . . .	3				
<b>Ribs</b> , long, arched, thickly fleshed . . . . .	8				
<b>Back</b> , broad, straight, thickly and evenly fleshed . . . . .	8				
<b>Loin</b> , thick, broad; thickness extending well forward . . . . .	8				
<b>Flank</b> , low and full . . . . .	2				
<b>Hooks</b> , smoothly covered; width in proportion to other parts, but not prominent . . . . .	3				
<b>Rump</b> , long, level, wide, and even; tail-head smooth, not patchy . . . . .	2				
<b>Pin bones</b> , not prominent, width in proportion with other parts . . . . .	1				
<b>Thighs</b> , full, fleshed well down to hock . . . . .	4				
<b>Twist</b> , deep, full; purse full . . . . .	4				
<b>Legs</b> , straight, short; arm full; shank fine, smooth . . . . .	2				
<b>Total</b> . . . . .	100				

Animal . . . . .

Student . . . . . Date . . . . .

## APPENDIX H

### THE AGE OF DOMESTIC ANIMALS AS INDICATED BY THE TEETH

The incisor teeth of the different domestic animals offer a convenient and comparatively accurate gauge as to their respective ages. The progressive incisive dentition of the horse, the cow, the sheep, and the pig are as follows:

#### THE HORSE

The horse has six incisors in either jaw, the middle pair of which are commonly known as the middles, the next pair as the intermediates, and the outer pair as the corners, or laterals.

At birth the colt is without incisors, the middle pair in either jaw appearing within a week or two, followed by the intermediates at the age of from two weeks to one month and by the corners at about five months. These constitute the milk, or colt, teeth, which are gradually replaced by the permanent ones as the colt nears maturity. The middle colt teeth drop out when the colt is about two years and a half old and are replaced at three years by the permanent teeth. At three and one-half years the intermediates are erupted, and at four their place is taken by their permanent successors. The corners are shed at about four and one-half years and replaced at five by the permanent corners. This is the last of the series of changes from colt to horse teeth, and the practically mature animal, at five years of age, possesses what is known as a full mouth, all the incisors being permanent and having in their bearing surfaces the black cups which are so plainly noticeable in the earlier life of the horse.

At six years of age the black cups have disappeared from the lower middle incisors; at seven, from the lower intermediates; at eight, from the lower corners; at nine, from the upper middles; at ten, from the upper intermediates; and at eleven, from the upper corners. The changes in the upper teeth do not take place with so much uniformity as those of the lower, and therefore are not so reliable as guides in age determination.

In addition to the replacing process and the loss of cups, the gradual changes in the shape and position of the teeth from maturity to death offer an approximate guide as to the age of their possessor. At maturity the incisors are short and wide and have a thickness equal to about one third of their width. At this time the teeth of the upper and lower jaws meet squarely and very nearly at right angles to the position of the jaws. As the animal grows older the teeth become longer, narrower, and thicker, and at the same time gradually incline forward and meet more nearly parallel with the jaws.

## THE COW

The cow has eight incisors in the lower jaw and none above. The middle pair, as in the horse, are known as the middles; the next, as the first intermediates; the third pair, as the second intermediates; and the outer pair, as the corners, or laterals.

At birth the calf usually possesses the middles; if not, they make their appearance in a very few days and are followed within the first month by the remaining incisors. When the animal is from eighteen to twenty-four months old the middle pair of milk teeth is erupted and the permanent ones take their place. A similar change occurs in the first intermediates at from twenty-seven to thirty-six months, in the second intermediates at from thirty-six to forty-eight months, and in the corners at from forty-five to sixty months. After this the age can be only roughly estimated from the wear shown by the teeth.

## THE SHEEP

The sheep, like the cow, has eight incisors in the lower jaw and none above.

Incisors are usually not present in the mouth of the lamb at birth, but by the end of the first month are all in. The milk teeth are replaced by the permanent teeth as follows: the middles, at from fifteen to eighteen months; the first intermediates, at about two years; the second intermediates, at from three to three and one-half years; and the corners, at from four to four and one-half years. After this the determination of age is largely a matter of guesswork, for the wear of the teeth varies greatly, and depends upon both the animal and the feed.

## THE PIG

The pig has six incisors in either jaw, the corner pairs being present at birth and the middles and intermediates appearing when the animal is three or four months old. At from six to ten months the corners are replaced by the permanent corners; the intermediates change at from twenty to twenty-four months and the middles at from thirty to thirty-six months. It will be noticed that this order of appearance of permanent teeth is the reverse of that of the horse, cow, and sheep, as it commences at the corners and works toward the center.

## APPENDIX I

### GENERAL SPRAY SCHEDULE FOR THE CONTROL OF THE IMPORTANT INSECTS AND DISEASES OF FRUITS AND VEGETABLES

PLANT	INSECT OR DISEASE	REMEDY	TIME TO APPLY REMEDY
Apple, pear, and quince	Codling moth	2 lb. arsenate lead *	Sprays † Nos. 3-4-6
	Curculio	2 lb. arsenate lead	Sprays † Nos. 2-3-4
	Spring cankerworm	3-4 lb. arsenate lead	Sprays † Nos. 2-3
	Aphis (plant lice)	Kerosene emulsion	When aphis appear
	San José scale	Lime-sulphur wash	Spray † No. 1
	Blotch	Bordeaux, 3-4-50	Sprays † Nos. 4-5-6
	Scab	Lime-sulphur wash	Sprays † Nos. 2-3-4
	Bitter rot	Bordeaux, 3-4-50	Sprays † Nos. 5-6-7
	Blister canker	Cut off cankers and spray woody parts.	Sprays † Nos. 4-5-6
		Bordeaux, 3-4-50	
	Fire blight	Cut off blighted twigs with sterile tool	Following blooming period
	Peach, plum, cherry, and apricot	Curculio	2 lb. arsenate lead
Aphis		Soap or tobacco solu- tion	As aphis appear
Brown rot		Self-boiled lime-sul- phur wash.	Spray † No. 1
Scab			
Leaf curl		Bordeaux or lime- sulphur wash	At ten-day intervals, follow- ing blooming period
Shot hole			
Brown rot			
Scab			
Grape	Berry moth	2 lb. arsenate lead	Before bloom, after fruit has set and ten days later
	Black rot	Bordeaux, 4-4-50	Before bloom, and after at seven-day intervals
	Downy and powdery mildew	Same as black rot; or, dry sulphur dust	Dust each seven days
	Leaf hopper	{ Kerosene emulsion Clean culture	Start as soon as hoppers ap- pear. Keep vines covered
Raspberry and blackberry	Anthracnose	{ Bordeaux, 4-4-50 Bordeaux, 2-4-50	Dormant
	Leaf spot		At ten-day intervals up to midseason

GENERAL SPRAY SCHEDULE FOR THE CONTROL OF THE  
IMPORTANT INSECTS AND DISEASES OF FRUITS AND  
VEGETABLES (CONTINUED)

PLANT	INSECT OR DISEASE	REMEDY	TIME TO APPLY REMEDY
Potato	Colorado beetle	3-4 lb. arsenate lead	Seven-day intervals, from appearance of beetles
	Flea beetles	Bordeaux, 4-4-50	Ten-day intervals, from appearance of beetles
	Dry rot (fusarium) Early blight Late blights	{ Clean seed and soil Bordeaux, 4-4-50	Select seed, rotate crops Ten-day intervals, from appearance of injury
	Scab	{ Soak seed two hours in formaldehyde (1 pt.) and water (30 gal.)	Before cutting; select clean soil
Cucumber, squash, and melons	Aphis	‡ pt. nicotine in 100 gal. water	As necessary to control
	Cucumber beetles Mildew } Fruit spot }	2-3 lb. arsenate lead. Also dust plant with drylime, ashes, or other dust. Bordeaux, 4-4-50	Start as injury appears; seven-day to ten-day intervals
	Wilt (bacterial)	Remove all affected vines. Control all insects	First appearance of wilting
Tomato	Black rot } Leaf blight }	{ Bordeaux, 4-4-50	At appearance of injury, or begin shortly before ripening, seven-day interval

† From 2 lb. to 50 gal. of water.

\* Spray No. 1. Dormant spray applied just before buds swell.

Spray No. 2. Summer strength, applied when cluster buds are pink, before blooming.

Spray No. 3. Apply when petals are about two thirds off flowers.

Spray No. 4. Apply three weeks after No. 2.

Spray No. 5. Apply five or six weeks after No. 2.

Spray No. 6. Apply ten weeks after No. 2.

Spray No. 7. Apply from two to four weeks after No. 6.

## APPENDIX J

### QUANTITY OF SEED TO SOW PER ACRE

<p>Alfalfa (broadcast) . . . . . 15 to 20 lb.                      Alfalfa (drilled) . . . . . 12 to 16 lb.                      Artichoke, Jerusalem . . . . . 6 to 8 bu.                      Barley . . . . . 8 to 10 pk.                      Bean, field, small varieties . . . . . 2 to 3 pk.                      Bean, field, large varieties . . . . . 5 to 6 pk.                      Beet . . . . . 4 to 6 lb.                      Brome grass . . . . . 12 to 15 lb.                      Broom corn . . . . . 3 pk.                      Buckwheat . . . . . 3 to 5 pk.                      Bur clover . . . . . 12 lb.                      Carrots (for stock) . . . . . 4 to 6 lb.                      Clover, alsike . . . . . 8 to 15 lb.                      Clover, Japan . . . . . 12 lb.                      Clover, mammoth . . . . . 12 to 15 lb.                      Clover, red (on small grain                          in spring) . . . . . 8 to 10 lb.                      Clover, sweet . . . . . 8 to 10 lb.                      Clover, white . . . . . 4 to 6 lb.                      Clover, crimson . . . . . 10 to 12 lb.                      Corn . . . . . 5 to 9 lb.                      Cotton . . . . . 1 to 3 bu.                      Cowpea . . . . . 1 to 1½ bu.                      Cowpea (drilled with corn) . . . . . ½ to 1 bu.                      Cowpea (for seed) . . . . . 3 pk.                      Field pea, small varieties . . . . . 2½ bu.                      Field pea, large varieties . . . . . 3 to 3½ bu.                      Flax (for seed) . . . . . 2 to 3 pk.                      Flax (for fiber) . . . . . 1½ to 2 bu.                      Hemp (broadcast) . . . . . 3½ to 4 pk.                      Hungarian grass (for hay) . . . . . 2 pk.                      Johnson grass . . . . . 1 to 1½ bu.                      Kafir (drilled for grain) . . . . . 5 to 8 lb.                      Kafir (for fodder) . . . . . 50 to 70 lb.                      Kale . . . . . 2 to 4 lb.                      Lupine . . . . . 1½ to 2 bu.                      Mangel . . . . . 5 to 8 lb.</p>	<p>Millet, barnyard (drilled) . . . . . 1 to 2 pk.                      Millet, German (for seed) . . . . . 2 to 3 pk.                      Millet, pearl (for hay) . . . . . 8 to 10 lb.                      Milo . . . . . 4 to 6 lb.                      Oat grass, tall . . . . . 30 lb.                      Oats . . . . . 2 to 3 bu.                      Orchard grass . . . . . 12 to 15 lb.                      Parsnips . . . . . 4 to 8 lb.                      Pop corn . . . . . 3 lb.                      Potato, Irish . . . . . 10 to 14 bu.                      Potato, Irish (cut to one or                          two eyes) . . . . . 6 to 9 bu.                      Rape (drilled) . . . . . 2 to 4 lb.                      Rape (broadcast) . . . . . 4 to 8 lb.                      Redtop, re-cleaned . . . . . 12 to 15 lb.                      Rice . . . . . 1 to 3 bu.                      Rutabaga . . . . . 3 to 5 lb.                      Rye . . . . . 3 to 4 pk.                      Rye grass . . . . . 2 to 3 bu.                      Sorghum (forage, broadcast) 1½ to 2 bu.                      Sorghum (for seed or sirup) 2 to 5 lb.                      Sorghum, saccharine (for                          silage or soiling, drilled) . 6 lb. to ½ bu.                      Soy bean (drilled) . . . . . 2 to 3 pk.                      Soy bean (broadcast) . . . . . 1 to 1½ bu.                      Sugar beets . . . . . 15 to 20 lb.                      Sugar cane . . . . . 4 tons of cane                      Sunflower . . . . . 10 to 15 lb.                      Timothy . . . . . 15 to 25 lb.                      Timothy and clover { timothy . . . 10 lb.                                                { clover . . . 4 lb.                      Turnip, (broadcast) . . . . . 2 to 4 lb.                      Turnip (drilled) . . . . . 1 lb.                      Velvet bean . . . . . 1 to 4 pk.                      Vetch, hairy (drilled) . . . . . 1 bu.                      Vetch, hairy (broadcast) . . . . . 1 to 1½ bu.                      Wheat . . . . . 3 to 9 pk.</p>
--	---



# APPENDIX K

## LEGAL WEIGHTS OF A BUSHEL

STATES	CEREALS						GRASS SEED				MISCELLANEOUS					
	Corn, shelled	Corn, ear	Wheat	Oats	Barley	Rye	Flaxseed	Millet	Timothy	Blue grass	Clover	Bran	Potatoes	Beans	Peas	Apples
<i>United States</i> . . .	—	—	60	32	48	56	56	—	—	—	—	—	60	—	60	—
Alabama . . .	56	70	60	32	47	56	—	—	—	—	—	—	60	60	60	—
Arizona . . .	—	—	60	32	45	56	—	—	—	—	—	—	—	55	—	—
Arkansas . . .	56	70	60	32	48	56	56	50	60	14	60	20	60	60	60	50
California . . .	—	—	60	32	50	54	—	—	—	—	—	—	—	—	—	—
Colorado . . .	—	70	60	32	48	56	—	—	45	14	60	—	60	60	—	—
Connecticut . . .	—	—	60	32	48	56	55	—	—	—	60	20	60	60	60	48
Delaware . . .	—	—	60	—	—	—	—	—	—	—	—	—	—	—	—	—
Florida . . .	56	70	60	32	48	56	—	50	—	—	—	20	60	60	—	48
Georgia . . .	56	70	60	32	47	56	56	—	45	14	60	20	60	60	60	—
Idaho . . .	—	—	60	36	48	56	56	—	—	—	60	—	60	—	—	45
Illinois . . .	56	70	60	32	48	56	56	—	45	14	60	20	60	60	—	—
Indiana . . .	56	68	60	32	48	56	—	50	45	14	60	—	60	60	—	—
Iowa . . .	56	70	60	32	48	56	56	50	45	14	60	20	60	60	—	48
Kansas . . .	—	70	60	32	48	56	56	50	45	14	60	20	60	60	—	48
Kentucky . . .	56	70	60	32	47	56	56	50	45	14	60	20	60	60	60	—
Louisiana . . .	—	70	60	32	48	56	—	—	—	—	—	20	60	60	60	—
Maine . . .	—	—	60	32	48	56	—	—	—	—	—	—	60	60	60	44
Maryland . . .	56	70	60	32	48	56	56	50	—	14	60	20	60	60	60	—
Massachusetts . . .	50	—	60	32	48	56	55	—	45	—	60	20	60	60	60	48
Michigan . . .	56	70	60	32	48	56	56	50	45	14	60	—	60	60	60	48
Minnesota . . .	56	70	60	32	48	56	—	48	45	14	60	—	60	60	60	50
Mississippi . . .	56	72	60	32	48	56	56	50	45	14	60	20	60	60	60	—
Missouri . . .	56	70	60	32	48	56	56	50	45	14	60	20	60	60	60	48
Montana . . .	56	70	60	32	48	56	56	—	45	14	60	20	60	60	60	45
Nebraska . . .	56	70	60	32	48	56	56	50	45	14	60	20	60	60	60	—
Nevada . . .	—	—	—	—	—	—	—	—	—	—	—	—	—	—	—	—
New Hampshire . . .	—	—	60	32	—	56	—	—	—	—	—	—	60	62	60	—
New Jersey . . .	—	—	60	30	48	56	55	—	—	—	64	—	60	60	60	50
New Mexico . . .	—	—	—	—	—	—	—	—	—	—	—	—	—	—	—	—
New York . . .	—	—	60	32	48	56	55	—	45	—	60	20	60	60	60	48
North Carolina . . .	—	—	60	32	48	56	55	—	—	—	60	—	—	—	60	—
North Dakota . . .	56	70	60	32	48	56	56	50	45	—	60	20	60	60	60	50
Ohio . . .	56	68	60	32	48	56	56	50	45	—	60	—	60	60	60	50
Oklahoma . . .	56	70	60	32	48	56	56	—	42	—	60	20	60	60	60	—
Oregon . . .	—	—	60	32	46	56	—	—	—	—	60	—	60	—	—	45
Pennsylvania . . .	—	—	60	32	47	56	—	—	—	—	60	—	56	—	—	—
Rhode Island . . .	56	70	60	32	48	56	56	50	45	—	60	20	60	60	60	48
South Carolina . . .	—	—	—	—	—	—	—	—	—	—	—	—	—	—	—	—
South Dakota . . .	56	70	60	32	48	56	56	—	42	—	60	20	60	60	60	—
Tennessee . . .	56	70	60	32	48	56	56	50	45	14	60	20	60	60	60	50
Texas . . .	56	70	60	32	48	56	56	50	45	—	60	20	60	60	—	45
Utah . . .	—	—	—	—	—	—	—	—	—	—	—	—	—	—	—	—
Vermont . . .	56	—	60	32	48	56	—	—	45	—	60	—	60	62	60	46
Virginia . . .	56	70	60	30	48	56	56	50	45	14	60	—	56	60	60	—
Washington . . .	—	—	60	32	48	56	56	—	—	—	60	—	60	—	—	45
West Virginia . . .	—	—	60	32	48	56	56	—	45	—	60	—	60	60	—	—
Wisconsin . . .	—	—	60	32	48	56	56	50	45	—	60	20	60	60	60	50
Wyoming . . .	—	—	—	—	—	—	—	—	—	—	—	—	—	—	—	—

# APPENDIX L

## A TABLE OF COMMON FARM WEEDS<sup>1</sup>

By reading from left to right the table gives the following facts about weeds: the common name; technical name; region where most injurious; the time of seeding; the place on the farm where the weeds grow and the crops injured by them; and the methods of eradication. Alternate cultivation as a means of eradication means cultivation during the dry season, and a heavy seeding for the growing season to an annual crop, such as crimson clover, cowpeas, millet, or oats, so that the weeds will be smothered.

COMMON NAMES	TECHNICAL NAME	WHERE INJURIOUS	TIME OF SEEDING	PLACE OF GROWTH AND PRODUCTS INJURED	METHODS OF ERADICATION
Barnyard grass, barn grass, cocksfoot Black mustard	Panicum crus-galli Brassica nigra	Minnesota to Montana Washington to California	July to September July to October	Fields; spring wheat Fields; grain crops	Prevention of seeding Prevention of seeding; hoed crops
Bracted plantain, rib grass, buckhorn, western buckhorn Broom rape	Plantago aristata Orobanche ramosa	Ohio to Iowa Kentucky to North Carolina	June to December July to September	Meadows; pastures Hemp; tobacco; tomatoes	Prevention of seeding; hoed crops Clean seed; cultivation of crops other than hemp, etc.
Buffalo bur, beaked horse nettle	Solanum rostratum	Iowa to Colorado	July to November	Grain; hoed crops	Heavy seeding; close cultivation
Bull thistle, common thistle	Carduus lanceolatus	Everywhere	July to November	Meadows; winter wheat	Prevention of seeding; cutting in fall
Bur grass, hedgehog grass, Rocky Mountain sand bur, sand bur, sand spur Burdock, great dock	Cenchrus tribuloides Arctium lappa	Everywhere New England to Wisconsin	July to November August to October	Sandy pastures; wool Waste places; pastures; wool	Cultivation; burning Prevention of seeding; grubbing in summer
Buttonweed, alligator head	Diodia teres	Maryland to Louisiana	July to November	Waste places; hoed crops; grainfields	Prevention of seeding; close cultivation
Canada thistle	Carduus arvensis	New England to Iowa	July to October	Fields; grain; meadows	Alternate cultivation and heavy cropping
Charlock, wild mustard, yellow mustard	Brassica arvensis	New England to North Dakota	June to October	Fields; grain	Prevention of seeding; cultivation; hoed crops
Chess, cheat, wheat thief, Willard's brome grass Chickweed	Bromus secalinus Stellaria media	New England to Washington New York to North Carolina	August to October March to July	Fields; grain Lawns, gardens; spring crops	Clean seed; cultivation Cultivation in late fall and early spring

<sup>1</sup>Adapted from *Farmers' Bulletin 28*, United States Department of Agriculture.

## A TABLE OF COMMON FARM WEEDS (CONTINUED)

COMMON NAMES	TECHNICAL NAME	WHERE INJURIOUS	TIME OF SEEDING	PLACE OF GROWTH AND PRODUCTS INJURED	METHODS OF ERADICATION
Chondrilla, gum succory, skeleton weed, stickweed	Chondrilla juncea	West Virginia to Maryland	July to December	Waste places; pastures	Cultivation; hoed crops
Clover dodder, alfalfa dodder, love vine	Cuscuta epithymum	Utah to Nebraska; New England	June to November	Clover; alfalfa	Clean seed; cultivation
Cockle, corn cockle, rose campion	Agrostemma githago	New England to Washington	July to September	Grainfields; wheat	Clean seed; cultivation
Cocklebur, clot bur, ditch bur, small burdock	Xanthium canadense, Xanthium strumarium	Everywhere	August to November	Waste places; pastures; wool	Prevention of seeding; cultivation
Couch grass, quack grass, quick grass, witch grass, devil's grass	Agropyron repens	New England to Minnesota	August to September	Fields; all crops except hay	Alternate cultivation and heavy cropping; close grazing
Cow herb, cockle, cow basil, cow fat, gland	Vaccaria vaccaria	Colorado to Utah	July to August	Fields; grain	Prevention of seeding; clean seed
Crab grass, finger grass, Polish millet	Panicum sanguinale	New Jersey to Missouri and south	July to October	Hoed crops	Prevention of seeding; closer cultivation
Curled dock, yellow dock	Rumex crispus	New England to Washington	July to October	Meadows; grain crops	Alternate cultivation and heavy cropping
Dandelion	Taraxacum taraxacum	Nearly everywhere	May to November	Meadows; lawns	Cultivation; digging roots in lawns
Devil's weed, devil's-paintbrush, king devil weed, golden hawkweed	Hieracium praealtum	New York	August to October	Meadows; pastures	Sheep pasturing; cultivation and heavy cropping
Dog fennel, Mayweed	Anthemis cotula	Everywhere	July to September	Roadsides	Prevention of seeding
English bindweed, morning-glory	Convolvulus arvensis	New England and California	August to October	Grainfields; hoed crops	Prevention of seeding; late cultivation
False flax, gold-of-plicasure, wild flax	Camelina sativa	Michigan to Minnesota	June to August	Flax and winter grain	Prevention of seeding
Field dodder, love vine, clover dodder	Cuscuta arvensis	New England to Ohio and southward	July to November	Clover; alfalfa	Clean seed; cultivation of crops other than clover
Fleabane, daisy fleabane, sweet scabious, whitetop	Erigeron annuus	Maine to Minnesota and south	July to September	Waste places; meadows	Prevention of seeding
Great ragweed, hogweed	Ambrosia trifida	Iowa to Louisiana and east	August to October	Bottom lands	Cultivation; heavy cropping
Gum plant, rosinweed, sunflower	Grindelia squarrosa	North Dakota to Utah	August to November	Meadows; pastures	Prevention of seeding; cultivation
Hedge bindweed, morning-glory	Convolvulus sepium	New Jersey to Illinois	August to October	Corn and wheat fields	Late cultivation
Horse nettle, bull nettle, sand briar	Solanum carolinense	Iowa to New Jersey and south	August to November	Waste land; meadows; pastures	Alternate cultivation and heavy cropping

A TABLE OF COMMON FARM WEEDS (CONTINUED)

COMMON NAMES	TECHNICAL NAME	WHERE INJURIOUS	TIME OF SEEDING	PLACE OF GROWTH AND PRODUCTS INJURED	METHODS OF ERADICATION
Horseweed, butterweed, colt's-tail, fleabane	Leptilon canadense	Everywhere	July to October	Waste land; meadows; grainfields	Prevention of seeding; late cultivation
Indian mallow, butterprint, stampweed, velvet leaf	Abutilon abutilon	Illinois to Iowa and Missouri	August to September	Cultivated lands	Prevention of seeding
Jimson weed, Jamestown weed, thorn apple	Datura tatula	Virginia to Texas	August to October	Waste places	Prevention of seeding
Johnson grass, Cuba grass, Australian millet, Egyptian millet, evergreen millet, Means's grass	Sorghum halepense	North Carolina to Texas and California	July to September	Cultivated fields; hoed crops	Alternate cultivation and heavy cropping
Lamb's-quarters, pigweed	Chenopodium album	Everywhere	August to November	Waste places	Prevention of seeding
Live-forever, garden orpine	Sedum telephium	New York to Pennsylvania	August to September	Fields	Infection with fungous disease; close cultivation
Malva, common mallow	Malva rotundifolia	California, Arizona	July to September	Fields	Prevention of seeding; thorough cultivation
Manroot, man-of-the-earth, morning-glory	Ipomoea pandurata	Delaware to Missouri	August to October	Fields	Prevention of seeding; killing roots with coal oil
Marsh elder, high-water shrub, false sunflower	Iva xanthifolia	Minnesota to Utah	September to October	Fields; pastures; grain crops	Prevention of seeding
Mexican tea, pigweed	Chenopodium ambrosioides	Virginia to Louisiana	August to October	Waste places	Prevention of seeding
Milkweed, cottonweed, silkweed	Asclepias syriaca	New York to Nebraska	August to September	Fields	Prevention of seeding; cultivation; heavy cropping
Morning-glory	Ipomoea purpurea	Delaware and California	August to December	Cultivated fields	Prevention of seeding; thorough cultivation
Moth mullein	Verbascum blattaria	Maryland to Ohio and Oregon	July to November	Meadows	Sowing clean seed; cultivation; grubbing in fall
Musky alfilerilla, ground needle, musky heronbill	Erodium moschatum	California to Arizona	May to August	Pastures	Sowing clean seed; burning
Narrow-leaved stickseed, beggar-ticks	Lappula lappula	Everywhere	July to October	Everywhere; wool; crops	Sowing clean seed; cultivation
Nut sedge, nut grass, coco sedge	Cyperus rotundus	Maryland to Arkansas and Texas	August to November	In hoed crops	Alternate cultivation and smothering crops
Orange hawkweed, ladies' paintbrush	Hieracium aurantiacum	New York and westward	August to October	Meadows; pastures	Prevention of seeding; cultivation; salt
Oxeye daisy, white daisy, whiteweed	Chrysanthemum leucanthemum	Maine to Virginia and Ohio	July to October	Meadows; pastures	Prevention of seeding; cultivation; salt

A TABLE OF COMMON FARM WEEDS (CONTINUED)

COMMON NAMES	TECHNICAL NAME	WHERE INJURIOUS	TIME OF SEEDING	PLACE OF GROWTH AND PRODUCTS INJURED	METHODS OF ERADICATION
Paraguay bur, sheep bur	<i>Acanthospermum xanthioides</i>	North Carolina to Florida	June to December	Waste places; pastures; wool	Cultivation
Pennycress, French-weed	<i>Thlaspi arvense</i>	North Dakota to Minnesota	June to December	Grainfields; pastures; dairy products	Burning; thorough cultivation
Pigeon grass, foxtail, yellow foxtail	<i>Setaria glauca</i>	Everywhere	July to November	Cultivated land; grain crops	Burning; thorough cultivation
Pigweed, careless-weed, rough amaranth	<i>Amarantus retroflexus</i>	Everywhere	August to November	Cultivated land; all crops	Prevention of seeding; thorough cultivation
Poison ivy, poison oak, poison vine	<i>Rhus radicans</i>	Everywhere	July to August	Waste land; poisonous to man	Cultivation; repeated grubbing
Poverty weed	<i>Iva axillaris</i>	Montana to New Mexico	July to September	Cultivated land; all crops	Closer cultivation; smothering crops
Prickly lettuce, compass plant, wild lettuce	<i>Lactuca scariola integrata</i>	Ohio to Iowa, and Utah to Oregon	July to November	Everywhere; all crops	Prevention of seeding; burning
Prickly pear, cactus, Western prickly pear	<i>Opuntia humifusa</i>	Oklahoma, Texas, New Mexico	July to December	Pastures	Permitting grass to grow and burning
Purslane, garden purslane, pursely, pusley	<i>Portulaca oleracea</i>	Everywhere	June to December	Cultivated land; garden crops	Closer cultivation
Ragweed, bitterweed	<i>Ambrosia artemisiifolia</i>	Everywhere	August to November	Everywhere; all crops	Prevention of seeding; burning
Rattlebox	<i>Crotalaria sagittalis</i>	Iowa to South Dakota	August to November	Pastures; poisonous to stock	Cultivation
Rib grass, black plantain, buckhorn, English plantain, lance-leafed plantain	<i>Plantago lanceolata</i>	Nearly everywhere	July to November	Everywhere; all crops	Clean seed; cultivation
Running brier, dew-berry, low black-berry	<i>Rubus villosus</i>	Maryland to North Carolina	June to August	Fields; all crops	Cultivation; smothering crops
Russian thistle, Russian cactus, Russian tumbleweed	<i>Salsola kali tragus</i>	Minnesota to Colorado	August to November	Everywhere; small grain	Cultivation; grazing; mowing for hay; burning
Shepherd's-purse	<i>Capsella bursa-pastoris</i>	Everywhere	May to December	Everywhere; all crops	Cultivation
Small carrot, bristly carrot, Southern wild carrot	<i>Daucus pusillus</i>	Georgia to Arizona	July to August	Everywhere; all crops	Prevention of seeding; cultivation
Smartweed, swamp persicaria, shoe-strings	<i>Polygonum amphibium emersum</i>	Ohio to Nebraska	August to September	Lowland; corn, grain	Prevention of seeding; cultivation
Sneezeweed	<i>Helenium autumnale</i>	North Carolina to Texas	August to October	Meadows; pastures	Cultivation
Sorrel, field sorrel, red sorrel, sourweed	<i>Rumex acetosella</i>	Nearly everywhere	June to November	Meadows; pastures	Cultivation; smothering crops
Sow thistle, field sow thistle, perennial sow thistle	<i>Sonchus arvensis</i>	New England to Wisconsin	August to November	Meadows; pastures; grain-fields	Thorough cultivation and smothering crops

A TABLE OF COMMON FARM WEEDS (CONTINUED)

COMMON NAMES	TECHNICAL NAME	WHERE INJURIOUS	TIME OF SEEDING	PLACE OF GROWTH AND PRODUCTS INJURED	METHODS OF ERADICATION
Spanish needles, bur marigold, beggarticks	<i>Bidens bipinnata</i>	Everywhere	July to November	Waste land; pastures	Prevention of seeding
Spiny amaranth, spiny careless weed, red careless weed	<i>Amaranthus spinosus</i>	Virginia to Texas	August to December	Waste land; pastures	Prevention of seeding
Spiny cocklebur	<i>Xanthium spinosum</i>	Maryland to Texas and California	August to November	Waste land; pastures; wool	Prevention of seeding; cultivation
Spiny nightshade	<i>Solanum aculeatissimum</i>	North Carolina to Mississippi	July to October	Waste places; pastures	Prevention of seeding; cultivation
Squirrel tail	<i>Hordeum jubatum</i>	Texas to Utah	July to October	Pastures	Prevention of seeding; cultivation
Star thistle, Texas thistle	<i>Centaurea americana</i>	Texas to Oklahoma	July to September	Cultivated land	Prevention of seeding; cultivation
Stubble spurge, spotted spurge	<i>Euphorbia nutans</i>	Maryland to Missouri	August to November	Cultivated land	Prevention of seeding; burning stubble
Sunflower, common sunflower	<i>Helianthus annuus</i>	Nebraska to Louisiana	August to October	Cultivated land	Prevention of seeding
Toadflax, butter and eggs	<i>Linaria linaria</i>	New England to Wisconsin	August to November	Meadows; pastures	Cultivation; heavy cropping
Teasel, fuller's card, Indian thistle	<i>Dipsacus sylvestris</i>	Ohio to Tennessee	August to October	Meadows; pastures	Prevention of seeding; cultivation
Trefoil, black medic, nonesuch	<i>Medicago lupulina</i>	New York to Virginia	April to December	Meadows; lawns	Clean seed; cultivation
Tumbleweed, pigweed	<i>Amaranthus graecizans</i>	Minnesota to Kansas	August to October	Cultivated land	Prevention of seeding; burning
Viper's bugloss, blue thistle, blueweed	<i>Echium vulgare</i>	New York to North Carolina	July to November	Meadows; pastures	Alternate cultivation and heavy cropping
Wheat thief, corn gromwell, field gromwell, pigweed	<i>Lithospermum arvense</i>	Michigan to Ohio	July to October	Grainfields	Sowing clean seed; cultivation with hoed crops
White heath aster, frostweed aster, fall aster	<i>Aster cricoides</i>	Maryland to Indiana	September to December	Meadows; pastures	Mowing; grazing with sheep; rotation of crops
Wild buckwheat, black bindweed	<i>Polygonum convolvulus</i>	Michigan to North Dakota	July to October	Grain and wheat fields	Sowing clean seed; cultivation
Wild carrot, bird's nest, devil's plague, Queen Anne's lace	<i>Daucus carota</i>	New England to Virginia	July to November	Meadows; pastures	Grubbing in fall; cultivation
Wild garlic, field garlic, crow garlic, wild onion	<i>Allium vineale</i>	Pennsylvania to South Carolina	August to September	Everywhere; dairy products; grain	Alternate cultivation and heavy cropping
Wild gourd, calabazita	<i>Cucurbita pennensis</i>	California to New Mexico	June to September	Cultivated land	Killing the roots with coal oil
Wild oats	<i>Avena fatua</i>	Minnesota to Oregon	July to September	Oat fields	Sowing clean seed; burning; pasturing

A TABLE OF COMMON FARM WEEDS (CONTINUED)

COMMON NAMES	TECHNICAL NAME	WHERE INJURIOUS	TIME OF SEEDING	PLACE OF GROWTH AND PRODUCTS INJURED	METHODS OF ERADICATION
Wild parsnip, queen-weed	<i>Pastinaca sativa</i>	New England to Wisconsin	July to October	Meadows; pastures	Prevention of seeding; cultivation Grubbing
Yarrow, milfoil	<i>Achillea millefolium</i>	Massachusetts to Minnesota	June to August	Meadows; pastures	Prevention of seeding; cultivation
Yellow daisy, black-eyed Susan	<i>Rudbeckia hirta</i>	New England to Ohio	July to September	Meadows; pastures	Prevention of seeding; cultivation
Yellow dock, bitter dock, broad-leaved dock	<i>Rumex obtusifolius</i>	New England to Wisconsin	August to October	Meadows; pastures	Prevention of seeding; cultivation
Yellow dog fennel, bitter weed	<i>Helenium tenitifolium</i>	Texas to North Carolina	August to November	Waste land; pastures; dairy products	Prevention of seeding; cultivation
Yellow melilot, yellow sweet clover	<i>Melilotus officinalis</i>	Maryland to Michigan	July to October	Dry meadows and pastures	Cultivation; increased fertilization





## INDEX

(Italic figures refer to a chapter, or section of a chapter, especially devoted to the topic under which they stand)

- Accounts on the farm, 442-446  
Acid phosphate, 105  
Africa, corn in, 134; rice in, 173;  
sorghums in, 223, 227; forests in,  
279  
Agee, Alva, 90, 114  
Air drainage, 122, 266-267  
Alabama, alfalfa in, 210  
Alfalfa, 8, 37, 38, 74, 125, 196, 204,  
210 *ff.*, 218, 287, 288, 328, 341, 345,  
365, 366, 401, 404-405, 427; water  
drawn from soil by, 29; food used  
by, 73; in rotation, 86, 213-214;  
history, 210; soil suited to, 211;  
manure and lime, 211-212; varieties  
of, 212; seeding of, 213; duration  
of stand, 213; hay from, 214; seed  
production, 214; weed pests, 214  
Alfalfa hay, 93, 346, 402, 403  
Allen, J. R., 455  
Alsike, 405  
America, wheat yields in, 5; farm  
incomes in, 6; pastures in, 192  
American Jersey Cattle Club, 371  
Ammonia, 95, 108  
Ammonification, 76  
Animals, feeding of. *See* Feeding  
animals  
Aphids, 315  
Apple aphids, 315  
Apple blotch, 291-292  
Apple scab, 289  
Apples, 9, 35, 43, 47, 262 *ff.*, 288;  
blight of, 289; black rot of, 290;  
scab of, 292  
Apricots, 9, 44  
Argentina, corn in, 135  
Arkansas, orchards in, 264  
Army worms, 310  
Arsenate of lead, 314-315  
Ash, 25, 325, 373, 401  
Ash, the, 280-281  
Asia, apples in, 262; forests in, 279;  
origin of poultry breeds in, 419  
Asia Minor, corn in, 134  
Asparagus, rust-resistant, 296  
Atlantic coast, wheat on, 161  
Augeas, quoted, 91  
Australia, corn in, 135; pastures in,  
192; forests in, 279  
Austria, rye in, 172  
Austria-Hungary, corn in, 135; sugar  
beets in, 236  
Ayrshire Breeders' Association, 371  
Babcock test, the, 377, 378, 379  
Bacon, C. W., 247  
Bacon, Francis, quoted, 1  
Bacteria, 68, 95, 110, 250, 288, 298,  
369, 374, 377  
Bailey, L. H., 48, 176, 203, 277, 329  
Balanced rations, 328, 340, 392-393  
Barley, 9, 60, 86, 171 *ff.*, 327, 367, 402;  
types of, 171; growth and use of,  
172; used as a nurse crop, 196,  
208; smut of, 293-294  
Barley and dry farming, 131  
Barnyard manure, 91 *ff.*, 112; impor-  
tance of, 91-92; value of, 92-93;  
effect of feeding on character of, 93;  
losses in, 94-95; fermentation of, 95;  
care of, 96; reinforced with phos-  
phates, 97-98; application of, 98-99  
Basic slag, 105  
Beans, 25, 36, 38  
Beeches, 63, 280-281  
Beef cattle, silage for, 259, 381 *ff.*;  
Shorthorns, 382; Herefords, 383;  
Aberdeen-Angus, 384; Galloways,  
385-386; standpoints from which  
to judge beef cattle, 386; judging  
beef cattle, 387-390; fattening cattle,  
392-393  
Beef production, 325, 381

- Bees, 302  
 Beets, 231, 234  
 Begonias, 40  
 Bergen and Caldwell, 34, 138  
 Better plants and animals. *See* Plants and animals  
 Bible, the, 372; quoted, 300, 320  
 Birches, 280-281  
 Birds as insect destroyers, 310-311  
 Bitter rot of apples, 292  
 Black knot of plums and cherries, 290  
 Black rot of apples, 290  
 Blue grass, 38, 328, 405  
 Blueberries, 63  
 Boll weevil, 186  
 Bollworm, 186  
 Bone meal, 104, 328  
 Bookkeeping on the farm, 442-446  
 Bordeaux mixture, 292, 316-317  
 Braconids, 309  
 Bran, 328, 341, 345, 366, 367, 393, 402, 429  
 Bread molds, 289, 299  
 Briggs and Shantz, 34  
 British India, sugar cane in, 237  
 Brooding, 431-432  
 Broom corn, 223-225  
 Brown, E., 434  
 Brown, William C., quoted, 49  
 Brown plum lice, 315  
 Brown rot of peaches and plums, 289, 292  
 BrownSwiss Breeders' Association, 371  
 Budding, 44  
 Bull, Ephraim, 10  
 Bumblebees, 209, 210  
 Burbank, Luther, 10  
 Burkett, C. W., 71, 81, 114, 176  
 Bursley, J. A., 455  
 Bushel, legal weights of (Appendix K), xvii  
 Business aspects of farming, 436 ff.  
 Business side of maintaining soil fertility, the, 120  
 Butter fat, 372, 375  
 Buttermilk, 404  
 Cabbage, 9, 25, 38, 53, 427  
 Calcium, 25, 77, 110, 327  
 California, wheat in, 160; barley in, 171; hemp in, 188; alfalfa in, 210; vetch in, 220; sorghums in, 227; sugar beets in, 237; orchards in, 264  
 Canada, oats in, 169; forests in, 279  
 Canada peas, 365  
 Candolle, Alphonse de, 8  
 Canker worm, 314  
 Cannas, 37, 41  
 Carbohydrates, 31, 325, 327, 340  
 Carbon, 25, 31, 33  
 Carbonic acid, 75, 104  
 Card, F. W., 277  
 Carrots, 231  
 Casein, 372, 373  
 Caterpillar, the, 186, 302  
 Cato, quoted, 381, 436  
 Cattle, 16, 17, 20. *See* Dairy cattle; *see also* Feeding animals  
 Cauliflower, 38  
 Cedars, 281  
 Celery, 38, 53  
 Central America, corn in, 137  
 Central states, planting corn in, 150  
 Charcoal, 425, 427, 429  
 Chase, L. W., 455  
 Cheese, 373  
 Cherries, 44, 263 ff., 281; black knot of, 290  
 Chestnut, the, 280-281  
 Chestnut-bark disease, the, 296  
 Chickens. *See* Poultry  
 Chile, alfalfa in, 210  
 China, corn in, 134; rice in, 173; sorghums in, 223; millet in, 229; apples in, 262; peaches in, 262  
 Chinch bugs, 302, 303-304  
 Chinese as farmers, 84, 101  
 Chlorophyll, 18, 31  
 Clay, Henry, 383  
 Climate as modified by forests, 282  
 Clover, 25, 37, 38, 62, 74, 86, 104, 111, 116, 118, 119, 125, 192, 204 ff., 218, 287-288, 328, 341, 345, 346, 393, 401, 427; food used by, 73; in rotation, 86  
 Clover hay, 93  
 Coburn, F. D., 222, 408  
 Codling moth, the, 305-306, 314  
 Coffee, 266  
 Coffee bean, the, 37  
 Coleus, 41, 47  
 Colorado, alfalfa in, 210; sugar beets in, 237; wheat in, 160  
 Colorado potato beetle, the, 313-314  
 Columbus, Christopher, 134  
 Columella, quoted, 23, 101, 210  
 Commercial fertilizers, 120  
 Computing fertilizer values, 108-109  
 Comstock, J. H., 312  
 Copper sprays, 316-317

- Corn, 2, 8, 9, 11-13, 24, 25, 26, 36, 38, 46, 75, 93, 109, 110, 116, 118, 119, 134*ff.*, 327, 328, 341, 345, 346, 365, 392, 393, 402, 404, 427, 429; water drawn from soil by, 29; diagram of grains of, 32; food used by, 73; in rotation, 86; history of, 134; production and distribution of, 135; uses of, 135; adaptation of, to climate and soil, 135-136; dent, 136; types of, 136; flint, 136-137; pod, 137; pop, 137; soft, 137; sweet, 137; plant of, 138; seed bed of, 138-139; importance of good seed, 139; regional varieties, 140-142; selecting seed ears, 142-144; maturity and soundness, 144; size and shape of ears, 144; character of kernel and germs, 145; uniformity of type, 146; storing seed, 146-147; testing and germination, 147-148; grading seed, 148; methods of planting, 148-149; rate of planting, 149; depth of planting, 150; time of planting, 150; cultivation, 150-152; harvesting, 152; smuts of, 294
- Corn chop, 366, 367
- Corn stover, 345, 366; digestibility of, 324
- Corn-and-cob meal, 366, 393
- Corn-ear worm, the, 303, 310
- Corn-root worm, the, 310
- Cornell Experiment Station, 437
- Correns, Carl, 14
- Cotton, 15-16, 177*ff.*; uses of, 177-178; history of, 178; kinds of, 178; plant of, 178-180; long-staple and short-staple, 180-181; separation of fiber from seed, 181-182; cottonseed products, 182-183; cotton soils, 183; climatic conditions, 183; fertilizers for, 183-184; planting and cultivating, 184; harvesting, 185; increasing yield by seed selection, 185-186; insect enemies, 186; diseases of, 186-187; wilt-resistant, 296
- Cotton seed, 37, 102
- Cotton wilt, 186, 290-291
- Cotton-boll weevil, the, 306-308
- Cottonseed meal, 93, 328, 341, 342, 345, 366, 367, 393
- Cotyledons, 36, 45
- Cowpea hay, 93; food removed from soil by, 73
- Cowpeas, 74, 88, 192, 204, 206, 218-220, 274, 328, 341, 367, 427; in rotation, 86; wilt-resistant, 296
- Crab grass, 214
- Cradle, the, 2-3
- Craig, John A., 352, 371, 417
- Cranberries, 63
- Crimson clover in orchards, 274
- Cross-fertilization, 138
- Crossing, 14-20
- Cross-pollination, 42
- Crown gall, 288
- Cuba, sugar cane in, 237
- Cucumbers, 28, 38; wilt of, 288
- Currants, 46
- Cuttings, 46-47
- Cutworms, 310
- Dairy cattle, 353*ff.*; silage for, 259; the dairy, 353; advantages of dairying, 353-354; the dairy herd, 354-355; Jerseys, 355-356; Guernseys, 356-357; Ayrshires, 357-358; Holsteins, 358-359; Brown Swiss, 359-360; Dutch Belted, 360; Milking Shorthorns, 360; selecting a dairy herd, 360-361; keeping records of cows, 361; selecting a dairy cow, 361-364; selection of the herd bull, 364; feeding the dairy herd, 364; when pastures fail, 365; feeding, 365-367; raising the calves on skim milk, 367-368; the dairy barn, 368-369
- Dairy products, 372*ff.*; recent progress, 372; what milk contains, 372-373; butter fat, 373; other components, 373-374; bacteria in milk, 374; separating cream from milk, 375-377; making butter, 377-378; Babcock test, 378
- Dates, 9, 263
- Davidson, J. B., 132, 455
- Dawson, H. C., 408
- Day, George E., 408
- Denitrification, 76
- Denmark, oats in, 169; farming in, 442
- Department of Agriculture, United States, 90, 91, 100, 114, 121, 126, 128, 132-133, 150, 155, 176, 190-191, 201, 203, 222, 226, 230, 241, 242, 245, 250, 260-261, 278, 286, 296, 299, 329, 352, 380, 394, 408, 417, 435, 455
- De Vries, Hugo, 14

- Dietrich, William, 408  
 Diseases of hogs, 405-406  
 Diseases of plants. *See* Plant diseases  
 Disking to destroy insects, 310  
 Diversified farming, 439-440  
 Doane, D. H., 417  
 Dock, 63, 111  
 Dodder, 287-288  
 Domestic animals, age of, indicated by teeth (Appendix II), xii-xiii  
 Dondlinger, P. T., 176  
 Dragon flies, 302, 308  
 Drainage, 122 *ff.*; effects of, 122; kinds of, 122-123; lands needing tiling, 123-124  
 Dried blood, 102, 326  
 Dry farming, 126 *ff.*; definition of, 126-127; dry-farming areas, 127-128; rainfall and other climatic conditions, 128; conserving moisture, 129; summer fallow, 129-130; crops for dry farming, 131  
 Dry rot of potatoes, 291  
 Ducks, 310. *See also* Poultry  
 Duggar, B. M., 34, 299  
 Duggar, J. F., 190, 247  
 Durra, 227  
 Dutch Belted Breeders' Association, 371  
 Ear-row method of selection, 13-14  
 Eckles, C. H., 371  
 Eggs, 326; testing of, 431. *See also* Poultry  
 Egypt, cotton in, 178  
 Electric motors, 454  
 Elliott, C. G., 132  
 Elms, 63, 281  
 Embryo, the, 35-36  
 Emmer, 403  
 England, consumption of sugar in, 236; beef cattle in, 381; swine in, 398; development of sheep in, 411-416; origin of poultry breeds in, 419  
 Ensilage. *See* Silos and silage  
 Enzymes, 18, 32, 36, 37, 289, 322, 327  
 Epidermis, 30  
 Erosion, 84-86  
 Europe, corn in, 135; apples in, 262; oranges in, 262; forests in, 279  
 Exercises, 45-48, 56-57, 69-71, 80-81, 90, 99, 113-114, 121, 154-155, 176, 190, 222, 230, 235, 261, 276-277, 285, 298-299, 319, 350-351, 370, 379-380, 447-448  
 Fallow, 128, 129-131  
 Farm, size of, in relation to profits, 436-439  
 Farm accounts, 442 *ff.*; keeping accounts, 442; inventories, 442-443; what accounts to keep, 443; how to keep accounts, 443-446  
 Farm incomes, 5-6  
 Farm management, 436 *ff.*; cardinal principles, 436; size of farm, 436-437; capital and profits, 437; why the small business does not pay, 437-439; diversification of farm operations, 439-440; distribution of farm labor, 440-441; horse labor, 441; utilization of farm products, 442  
 Farm products, standardization of, 442  
 Fat, 325-326, 327  
 Fattening cattle, silage for, 259, 392-393  
 Feeding animals, 320 *ff.*, 339-346, 365-368, 401-405, 425-429; animal products, 320; uses of feed, 320-321; regulation of maintenance feed, 321; what the animal produces, 321-322; digestion of feed, 322-323; improved and poor animals compared, 324; digestibility of feeds, 324-325; feeding and watering, 325; protein, 325-326; carbohydrates, 327; fats, 327; mineral nutrients, 327-328; balanced rations, 328; why animals fatten, 328  
 Fertility. *See* Soil fertility  
 Fertilizers, commercial, 101 *ff.*, 183-184; need of, 101; extent of use of, 101-102; dried blood, 102; nitrate of soda, 102; nitrogenous, 102; sulphate of ammonia, 102; tankage, 102; low-grade nitrogenous, 103; phosphatic, 103-104; bone-meal, 104; phosphate rock, 105; potassium fertilizers, 105-106; potassium chloride, 106; potassium sulphate, 106; wood ashes, 106; mixed fertilizers, 107-108; fertilizer formulæ, 108; state control, 108; computing fertilizer values, 108-109; applying fertilizers, 109; home mixing of fertilizers, 109; fertilizers for different crops, 109-110; lime, 110-112; possible injury to soil, 112. *See also* Barnyard manure  
 Feterita, 227  
 Fiber crops, 177 *ff.* *See also* Cotton, Flax, Hemp

- Field peas, 403, 405; in rotation, 86  
 Figs, 9  
 Fippin, E. O., 71, 81  
 Firs, 280-281  
 Flax, 187-188; wilt of, 291  
 Fletcher, S. W., 57, 71, 90, 277  
 Flies, 96, 302  
 Floods, prevention of, by forests, 282  
 Florida, tobacco in, 244, 245; oranges in, 263; orchards in, 264; sea-island cotton in, 178  
 Food. *See* Plant food  
 Forage crops, 223 *ff.*; sorghums, 223-224; sorgo, 224; kafir, 225-226; kaoliang, 226, shallu, 226-227; durra, 227; milo, 227; feterita, 227; regions favorable to sorghums, 227; culture, 227-228; rape, 228-229; millet, 229  
 Forests. *See* Wood crops  
 Formalin, 311  
 Fowls, manure of, 93  
 Foxtail, 214  
 France, farm incomes in, 6; wheat yield in, 6; oats in, 169; alfalfa in, 210; development of sheep in, 410-411  
 Frear, William, 247  
 Freemañ, E. M., 299  
 Froubert, C. L., 247  
 Fruit judging, 277  
 Fuller, A. S., 48, 277  
 Fungi, 68, 288-289, 316  
 Fungicides, 313 *ff.*  
 Garner, W. W., 247  
 Gas engines, 451-454  
 Gasoline engines, 451-454  
 Gay, C. W., 352, 394  
 Geese, 310. *See also* Poultry  
 Georgia, sea-island cotton in, 178  
 Geraniums, 40, 41, 42, 47  
 Germany, wheat yield in, 5; farm incomes in, 6; oats in, 169; barley in, 171; rye in, 172; alfalfa in, 210; sugar beets in, 236  
 Glucose, 31  
 Gluten, 367  
 Gooseberries, 46  
 Grafting, 41, 42, 43, 47-48  
 Grain farming and soil fertility, 118  
 Grapes, 9; origin of Concord, 9-10  
 Grasses, 192 *ff.*; most important crop, 192-193; pasturing, 193; how grasses increase, 194-195; hay and pasture mixtures, 195-196; seeding, 196; timothy, 197-198; Kentucky blue grass, 198-200; Canada blue grass, 200; keeping pastures clean, 200; Bermuda grass, 201; brome grass, 201; meadow fescue, 201; orchard grass, 201; carpet grass, 202; Johnson grass, 202; Rhodes grass, 202; Sudan grass, 202  
 Grasshoppers, 301, 302, 310  
 Graves, Henry S., 286  
 Greece, alfalfa in, 210; consumption of sugar in, 236  
 Green, S. B., 277, 286  
 Green manure, 62, 88-89, 105, 112, 118, 220  
 Green melon lice, 315  
 Grit, 427, 429  
 Ground beetles, 308  
 Guanos, the, 102  
 Guernsey, dairying in, 356  
 Guernsey Breeders' Association, 371  
 Guineas, 310. *See also* Poultry  
 Gulf states, planting corn in, 150  
 Gum trees, 281  
 Hall, J. G., 299  
 Hanson, Timothy, 197  
 Harper, M. H., 394  
 Hawaiian Islands, sugar cane in, 237  
 Hay, 3, 25, 192-193, 209, 214, 217, 219-220, 326, 340, 342-343, 345, 346, 366, 367, 393, 402, 404  
 Helpful insects, 308-309  
 Hemlocks, 280-281  
 Hemp, 9, 188-189  
 Henry, W. A., 134, 329, 394  
 Herd, John, 197  
 Hessian fly, 310  
 Hibshman, E. K., 247  
 Hickory, 63, 281  
 Hirshfeld, C. F., 455  
 Hogs, 18-19; manure of, 93. *See* Swine; *see also* Feeding animals  
 Holland, dairying in, 353  
 Holstein-Friesian Breeders' Association, 371  
 Homer, quoted, 91  
 Honey bees, 239-240, 308  
 Hopkins, C. G., 57, 71, 75, 81, 90, 100, 114  
 Horace, quoted, 279  
 Horse labor, 441

- Horses, 330 *ff.*, 16; manure of, 93; silage for, 259; importance of, 330; history of, 330-331; Arabian, 331-332; Thoroughbred, 332-333; Standard Bred, 333-334; American Saddle, 334; Morgan, 334; Percheron, 334-335; Belgian, 335-336; English Shire, 336-337; Clydesdale, 337; ponies, 337; labor of, 441. *See also* Feeding animals
- Horses and mules, 330 *ff.*; feeding, 339-346; watering, 346-347; market classes of, 348-349
- Hume, H. Harold, 277
- Humus, 52
- Hunt, Thomas F., 71, 155, 176, 230
- Ichneumon flies, 308-309
- Idaho, alfalfa in, 210
- Illinois, corn in, 135, 140; wheat in, 160; oats in, 169
- Illinois Experiment Station, 86, 115
- Importance of legumes, 87
- Incubating and incubators, 430-431
- India, rice in, 173; cotton in, 178; sorghums in, 223; millet in, 229
- Indian corn. *See* Corn
- Indiana, corn in, 135, 140; wheat in, 160; pastures in, 198; tobacco in, 245
- Indo-China, oranges in, 262
- Ingalls, John James, quoted, 192
- Inoculation for legumes, 205-206
- Inoculation of soil, 78-79
- Insect pests, 423-424
- Insecticides, 313 *ff.*
- Insects, 186
- Insects on the farm, 300 *ff.*; importance of, 300-301; structure and ways of feeding, 301; changes in form of, 302; chinch bug, 304-305; codling moth, 305-306; cotton-boll weevil, 306-308; helpful insects, 308-309; preventing and controlling insect injuries, 309-311
- Intensive agriculture, 6
- Invention as aid to agriculture, 2-4
- Iowa, corn in, 135, 140, 142, 149; wheat in, 160; oats in, 169
- Ireland, farming in, 442
- Irrigation, 124 *ff.*; object of, 124-125; how water is applied, 125-126
- Italy, alfalfa in, 210; consumption of sugar in, 236
- Japan, wheat in, 5, 167; farm incomes in, 6; irrigation in, 127; rice in, 173; millet in, 229
- Japan clover, 217, 405
- Java, sugar cane in, 237
- Jersey, dairying in, 353, 355
- Jesuits, the, introducers of cane sugar, 237
- Johnston, J. H. S., 352
- Jordan, W. H., 329
- Judging beef cattle, 386-391
- Judging dairy cattle, 361-364
- Judging horses, 347, 350-351
- Kafir, 223, 225-226, 327, 366, 393, 402, 427
- Kainite, 105
- Kansas, corn in, 135, 140, 149; alfalfa in, 210; sorghums in, 227; mules produced in, 338
- Kansas State Agricultural Experiment Station, 162, 403
- Kaoliang, 226
- Kellogg, V. L., 312
- Kentucky, wheat in, 160; hemp in, 188; pastures in, 193; mules produced in, 338; swine in, 400; tobacco in, 244, 245, 246
- Kentucky Agricultural Experiment Station, 206
- Kerosene, 316, 424
- King, F. H., 57, 71, 81, 85, 371
- Kleinheinz, Frank, 417
- Korea, millet in, 229
- Labor on the farm, distribution of, 440-441
- Lactic acid, 374, 377
- Lane, C. B., 371
- Lard type of hog, 395-396.
- Lawes, John Bennet, 53
- Layers, 39-40, 46
- Leaf curl of peaches, 292
- Legume hay, 326, 345
- Legumes, 25, 63, 77, 79, 86, 88-89, 111, 118-119, 196, 204 *ff.* (*see also* Red clover, Alfalfa, Sweet clover, Japan clover, Cowpeas, Soy beans, and Vetches); use in maintaining fertility, 87; importance of, 204; legumes and nitrogen, 205; inoculation for, 205-206
- Lettuce, 28, 316
- Lewis, H. R., 434
- Liebig, Justus von, 3-4

- Lime, 54, 63, 110-112, 211-212  
 Lime spray, 315  
 Linseed meal, 93, 102, 187, 328, 342, 345, 346, 366, 367, 393, 402, 427  
 Linseed oil, 187  
 Lipman, J. G., 81, 90  
 Lippincott, W. A., 435  
 Live stock, and soil fertility, 115-118; on pasture, 193  
 Living, high cost of, 5  
 Livingston, G., 176  
 Loess, 55  
 Loss of organic matter and nitrogen, 83  
 Louisiana, rice in, 174; introduction of sugar cane into, 237  
 Lucke, C. E., 455  
 Lyon and Fippin, 57, 71, 81, 114
- McCormick, Cyrus Hall, 2, 168  
 McCormick, Robert, 168  
 MacDonald, William, 132  
 McKay and Larson, 380  
 Magnesium, 25, 327  
 Maize. *See* Corn  
 Mangel-wurzels, 234, 427  
 Manure, 118, 200, 211-212, 231-232. *See also* Barnyard manure  
 Maples, 280-281  
 Martineau, G., 241  
 Maryland, tobacco in, 246  
 Mass selection, 13-14  
 Massachusetts, tobacco in, 244  
 Matthewson, E. H., 247  
 Meat meal, 326, 328, 402  
 Meat scraps, 425, 429  
 Mechanical power for the farm, 449 *ff.*; windmill, 449; water motor, 449-450; steam power plant, 450; oil engine, 450-451; action of gas engines and oil engines, 451-453; selecting and installing oil engines, 453-454; electric motors on the farm, 454  
 Media, alfalfa in, 210  
 Melons, 38; wilt of, 288  
 Mendel, Gregor, 14  
 Mendel's Law, 14-20  
 Metamorphosis of insects, 302  
 Mexico, corn in, 135  
 Michels, John, 371  
 Michigan, corn in, 140; rye in, 172; sugar beets in, 237; peaches in, 267; cattle in, 385  
 Middlings, 342, 402, 429
- Milk, 326, 328; digestibility of, 324  
 Milk sugar, 374  
 Millet, 9, 38, 93, 192, 229, 343; water drawn from soil by, 29; smuts of, 293-294  
 Milo, 227, 327, 402  
 Mineral nutrients, 327  
 Minnesota, corn in, 140, 141; wheat in, 158; oats in, 169; barley in, 171; rye in, 172; alfalfa in, 210  
 Mississippi, alfalfa in, 210; mules produced in, 338  
 Mississippi Valley states, cherries in, 264  
 Missouri, corn in, 135, 140, 149; wheat in, 160; hemp in, 188; pastures in, 193; orchards in, 264; mules produced in, 338  
 Missouri, University of, 441  
 Missouri Experiment Station, 86, 88, 115  
 Mistletoe, 288  
 Mites, 423-424  
 Montana, wheat in, 160; alfalfa in, 210  
 Montgomery, E. G., 155  
 Mulches, 66-67  
 Mules, 338, 349  
 Mumford, H. W., 394  
 Mutton, sheep for, 409, 411-415  
 Myrick, H., 241
- National ownership of forests, 282-284  
 Nebraska, corn in, 135, 140, 149; wheat in, 160; hemp in, 188; alfalfa in, 210  
 Nectarines, 44  
 New agriculture, the, 1 *ff.*  
 New England, corn in, 137, 141-142; hemp in, 188; orchards in, 263  
 New Jersey, orchards in, 263; swine in, 397  
 New York, rye in, 172; tobacco in, 244; orchards in, 263; swine in, 397  
 Nitrate of soda, 102  
 Nitric acid, 75  
 Nitrification, 76  
 Nitrogen, 25, 33, 72 *ff.*, 82-83, 92, 94, 116, 118-119, 183-184, 200, 204-206, 231  
 Nitrogenous fertilizers, 102-103  
 North America, corn in, 134; forests in, 279  
 North Carolina, tobacco in, 245  
 North Dakota, corn in, 140, 142; wheat in, 158; alfalfa in, 210

- North Dakota Experiment Station, 159  
 Northern states, planting corn in, 150  
 Nurse crops, 196
- Oak, the, 43, 63, 281
- Oats, 38, 60, 86, 110, 116, 118, 119, 169 *ff.*, 196, 340, 341, 346, 365, 367, 393, 405, 427, 429; water drawn from soil by, 29; food used by, 73; in rotation, 86; oats and dry farming, 131; introduction of, 169; regions of growth of, 169; cultivation of, 170; harvesting, 170; used as a nurse crop, 196, 208-209; smut of, 293-294
- Ohio, corn in, 135, 140; wheat in, 160; sugar beets in, 237; tobacco in, 244, 245, 246
- Ohio Experiment Station, 97
- Oil engines, 450-454
- Oil meal, 341
- Oil of tar, 281
- Oklahoma, corn in, 149; wheat in, 160; sorghums in, 227; mules produced in, 338
- Olive oil, 328
- Olives, 9, 263
- Onions, 9, 38, 46, 53
- Oranges, 35, 262 *ff.*
- Orchard, sprayers for, 318
- Orchards, 262 *ff.*; origin of the apple, 262-263; orchard regions of the United States, 263-264; climate, 264; soils, 264-265; sites, 265-266; air drainage, 266-267; bodies of water, 267; preparing the land, 267; varieties to plant, 267; planting, 268-269; shaping the top, 269; pruning for open form, 270; pruning for pyramidal form, 270-271; making trees bear fruit, 271-272; orchard cultivation, 272-274; when to pick fruit, 274-275
- Oregon, wheat in, 161; alfalfa in, 210; vetch in, 220
- Oregon Agricultural College, 420
- Organic matter, 25
- Osage orange, 43
- Osmotic pressure, 27
- Overproduction, 5
- Oxygen, 25, 31, 33
- Oyster shells, 425, 427
- Paddock, W., 277
- Palestine, wheat in, 166
- Palladius, quoted, 204
- Palms, 266
- Parasites, 287-289
- Parasitic insects, 308-309, 422-424
- Paris green, 314-315
- Parsnips, 38, 231
- Pastures, 365, 368, 404-405; in rotation, 86
- Pasturing. *See* Grasses
- Pawpaws, 63
- Peaches, 9, 35, 44, 262 *ff.*; brown rot of, 289, 292; leaf curl of, 292; scab of, 292
- Peanuts, 328, 404, 405
- Pears, 9, 35, 263 *ff.*; blight of, 288, 289-290
- Peas, 14-15, 25, 38, 62, 403, 404, 429; water drawn from soil by, 29
- Pennsylvania, wheat in, 160; rye in, 172; cattle in, 385; swine in, 398
- Persia, alfalfa in, 210; peaches in, 262
- Pheasants. *See* Poultry
- Philippines, the, rice in, 173; sugar cane in, 237
- Phosphate rock, 105
- Phosphates, 97-98
- Phosphatic fertilizers, 103-105
- Phosphorus, 25, 33, 72 *ff.*, 92, 94, 116, 118-119, 184, 231, 327
- Pigeons. *See* Poultry
- Pigweed, water drawn from soil by, 29
- Pines, 63, 280-281
- Pit silos, 258
- Pitch, 281
- Plant diseases, 186-187, 287 *ff.*; due to parasitic plants, 287-288; bacteria, 288; fungi, 288-289; control by pruning, 289-290; control by crop rotations, 290-291; control by spraying, 291-292; apple blotch, 292; control by seed disinfection, 293; preventive treatment of smut, 294-295; control by growth of resistant varieties, 295-296; sanitation and quarantine, 297
- Plant food in soil, 72 *ff.*; important elements in, 72; available and unavailable, 72-73; amount used, 73-74; amount in soils, 74; amount available in a season, 75; how potassium and phosphorus are made available, 75-76; how nitrogen is



- made available, 76; conditions favorable to nitrification, 76-77; adding nitrogen to the soil, 77-79; chemical analysis of soil, 79; value of plant food, 79-80; loss of, 83-84
- Plants, feeding and growth of, 23 *ff.*; factors determining the harvest, 23; climate, 23-24; where plants obtain food, 24; composition of plants, 25; elements of plant food, 25-26; how plants obtain food, 26; root hairs, 26-28; use of water by plants, 28-31; how organic matter is made, 31-32; propagation of, 35 *ff.*; embryo, 36; requirements of germination, 36-37; life of seeds, 37-38; seed planting, 38; bud growth, 38-39; layers, runners, and root tips, 39-41; separation and division, 41; cuttings, 41-42; grafting, 43; budding, 44
- Plants and animals, improvement of, 8 *ff.*; ancient and modern improvements, 8-9, 21; nature of improvements, 8-9, 21, 139-140; examples of improvement, 9-11; systematic selection, 10-14, 140, 143-146; earrow method, 11, 13-14; continuous care, 12-13, 20-21, 138; hybridization, 14-19; Mendel's Law, 14-19
- Pliny, quoted, 156
- Plowing, value of deep, 162-164; to destroy insects, 309
- Plumb, C. S., 352, 371, 394
- Plums, 43, 44, 263 *ff.*; black knot of, 290
- Poisons for insects, 301, 306, 309
- Pollination, 154, 209
- Poplars, 281
- Potash, 108, 184, 231
- Potassium, 25, 72 *ff.*, 92, 94, 96, 116, 118-119, 327
- Potassium chloride, 106
- Potassium fertilizers, 105-107
- Potassium sulphate, 106
- Potato, the Burbank, 10
- Potatoes, 25, 35, 42, 46, 106, 107, 110, 218, 231, 232, 233-234; water drawn from soil by, 29; potatoes and dry farming, 131; blight of, 287, 291-292; wilt of, 288; scab of, 289; dry rot of, 291
- Potter, A. A., 455
- Poultry, 418 *ff.* (*see also* Feeding animals); to kill insects, 310; importance of industry, 418; poultry chiefly chickens, 418; primary poultry product, 418-419; classes of chickens, 419; breeds and varieties, 420; farm poultry, 421; essentials of a good poultry house, 421-422; sanitation of chicken houses, 422-424; feeds and feeding, 425; scratching feed and the mash, 426-427; typical rations for laying hens, 427-428; rations for young chickens, 428-429; saving eggs for hatching, 429; incubating, 430; management of the incubator, 430-431; brooding, 431-432; saving eggs for market, 432-433; fertile and infertile eggs, 431, 433; best eggs for market, 433
- Production, history of, 3-6
- Protein, 31, 33, 93, 325, 340, 401, 425
- Pruning, 269-272
- Puff balls, 289
- Pupa, the, 302
- Purdue Agricultural Experiment Station, 394, 424
- Purdue University, 332
- Purvis, Miller, 435
- Questions and problems, 7, 22, 33-34, 45, 56, 69, 80, 89, 99, 113, 120, 131-132, 153-154, 175, 189, 202-203, 221, 229-230, 234-235, 240, 246, 259-260, 275-276, 285, 298, 311, 318-319, 329, 349, 350, 370, 378, 394, 407, 416, 434, 447, 454-455
- Quicklime, 112
- Quinces, 9, 43; blight of, 289
- Rape, 228-229, 328, 401, 405
- Raspberries, 41
- Rations, 320 *ff.*; for horses, 339 *ff.*
- Reaping machine, the, 2
- Red clover, 207 *ff.*, 228, 405; distribution and adaptation of, 207; importance of, 207; getting stand of, 207-208; nurse crop for, 208-209; hay from, 209; seed production, 209-210
- Redtop, 111, 195-196
- Redwoods, 281
- Removal of plant food, 83-84
- Resistant varieties of plants, 296
- Rhode Island, corn in, 142

- Rice, 9, 125, 173*f.*, 429; where grown, 173; cultivation of, 173-174; harvesting, 174
- Roberts, J. P., 100
- Robinson, J. H., 435
- Roman farming, 91
- Romans, the, use of agricultural implements by, 168
- Root hairs, 26-28
- Root rot of tobacco, 291
- Root tips, 41
- Roots and tubers, 231*ff.*; value of, 231; importance of, 231; soils adapted to, 231-232; the potato, 233; time of planting, 233; beets, 234; sweet potatoes, 234
- Rose, Laura, 380
- Roses, 288
- Rotation of crops, 86-87, 116, 164, 287, 291, 310
- Roughage, 342-343, 392
- Russia, oats in, 169; barley in, 171; flax in, 187; pastures in, 192; sugar beets in, 236; forests in, 279
- Russian thistle, water drawn from soil by, 29
- Rusts of grain, 287, 295-296
- Rye, 38, 62, 86, 110, 172, 327, 342; water drawn from soil by, 29; in orchards, 274
- Sanderson and Jackson, 312
- Sanitation, 297, 405-406, 421-424
- San José scale, the, 315
- Sargent, F. L., 155
- Scab of apples, 292
- Scherrfus, W. H., 247
- Science as aid to agriculture, 2-4
- Score cards (Appendixes A, B, C, D, E, F, G), i-xi
- Scotland, cattle in, 384-385
- Scratching shed, 426-427
- Sears, F. C., 319
- Seed, quantity of, per acre (Appendix J), xvi
- Seed selection, 10-14; of corn, 142-146
- Seeds, germination of, 36-37; life of, 37-38; alfalfa, 37; canna, 37; clover, 37; coffee bean, the, 37; cotton seed, 37; locust seeds, 37; stratification, 37; planting of, 38; testing for germination, 147-149
- Separating cream from milk, 375-377
- Shakespeare, William, quoted, 330
- Shallu, 226-227
- Shaw, Thomas, 132, 222, 230
- Sheep, 409*ff.* (*see also* Feeding animals); manure of, 93; silage for, 259; development of types of, 409; characteristics of types, 409-410; fine-wool breeds, 410; American Merino, 410-411; Delaine Merino, 411; Rambouillet, 411; middle-wool breeds, 411; Southdown, 412; Shropshire, 412-413; Hampshire Down, 413; Oxford Down, 414; Dorset Horn, 414-415; Leicester, 415; long-wool breeds, 415; Cotswold, 416; Lincoln, 416
- Shirreff, Patrick, 10-11
- Shorts, 342, 367, 402, 427
- Sickle, the, 2-3
- Silage, 344, 346, 365, 366, 393, 427
- Silkworms, 308
- Silos and silage, 248*ff.*; green and dried fodders compared, 248-249; how silage keeps, 249-250; advantages of the silo, 250-251; silos and crop limits, 251; silage crops, 252; essentials of the silo, 252-253; feeding silage when fresh, 253; sizes of silos, 254-255; cost of silos, 255; when to cut crops for silage, 255, 256; filling the silo, 257; pit silos, 258; amount of silage to feed, 259
- Size of farm, 436-439
- Skim milk, 326, 328, 367-369, 402, 404
- Slingerland and Crosby, 312
- Smith, Adam, quoted, 115
- Smuts of grain, 287, 293-295
- Smythe, William E., 132
- Snyder, Harry, 90, 100, 114, 121
- Soil, the, 49*ff.*; definition of, 49-50; formation of, 50; kinds of, 52-53; mineral matter of, 52-53; cumulose, 53-54; glacial, 54; transported, 54; æolian, 55; colluvial, 55; significance of type of, 55; properties of, 58*ff.*; texture, 58-59; weight, 59; texture and crop growth, 60-61; structure of, 61; poor physical condition, 62; color as indicator of value, 62-63; plant growth as indication of fertility, 63; soil water, 64-66; mulch, 66-67; temperature, 67; life in soil, 68

- Soil fertility, relation of type of farming to, 29, 115 *ff.*; maintenance of, 82 *ff.*; returning the, removed in crops, 115; live stock and, 115-118; grain farming and, 118-119; balance of gain and loss, 119-120; the business side of maintaining, 120
- Soils, and fertilizers, 109; for roots and tubers, 231-232
- Sorghums, 9, 24, 218, 223-228, 327, 345, 346, 365, 393, 405; water drawn from soil by, 29; sorghums and dry farming, 131; smuts of, 293-294
- Sorrel, 63, 111
- Sotham, W. H., 383
- South, the, corn in, 141, 142, 149; oats in, 169; rice in, 173; cotton in, 178; Bermuda grass in, 201; carpet grass in, 202; Japan clover in, 217; vetch in, 220
- South America, corn in, 135, 137; pastures in, 192; sugar cane in, 237; forests in, 279
- South Carolina, sea-island cotton in, 178; tobacco in, 245
- South Dakota, corn in, 140, 142; wheat in, 158; alfalfa in, 210; kaoliang in, 226
- Soy beans, 204, 220, 328, 404; in orchards, 274
- Spain, alfalfa in, 210; development of sheep in, 410
- Specialized farming, 439-440
- Spillman, W. J., 203
- Spray schedule (Appendix I), xiv-xv
- Spraying, 291-292, 313 *ff.*, 424; significance of, 313-314; insecticides, 314-316; spraying for fungous diseases, 316; copper sprays, 316-317; apparatus for spraying, 317-318
- Spruces, 280-281
- Standardization of farm products, 442
- State ownership of forests, 282
- Stevens, F. L., 299
- Stover, 93, 346
- Straw, 93, 325, 342, 393
- Strawberries, 39
- Sudan grass, 202
- Sugar, 31-32, 236 *ff.*, 372; importance of, 236; sugar beets, 236-237; sugar cane, 237-238; sugar maples, 239; honey bees, 239-240
- Sugar beets, 236-237, 367; water drawn from soil by, 29
- Sugar cane, 35, 237-238
- Sugar maple, the, 239
- Sulphate of ammonia, 102
- Sulphuric acid, 103
- Sunflowers, 26, 30
- Surface washing, 84-86
- Sweden, oats in, 169
- Sweet clover, 216-217, 405; water drawn from soil by, 29
- Sweet potatoes, 231, 234
- Swine, 395 *ff.*; origin of, 395; the lard hog, 395-396; the Poland China, 396-397; Duroc-Jersey, 397; Berkshire, 398; Chester White, 398-399; bacon hog, 399; Large Yorkshire, 399; Tamworth, 400; Hampshire, 400-401; management of herd, 401-402; feeding young pigs, 402; finishing hogs for market, 402-403; feed for fattening hogs, 403; balanced rations for feeding, 403-404; hog pasturage, 404-405; sanitation and common diseases of hogs, 405-406
- Tankage, 93, 102, 326, 328, 402
- Tennessee, wheat in, 160; pastures in, 193; tobacco in, 246; mules produced in, 338
- Testing eggs, 431
- Texas, sorghums in, 227; mules produced in, 338
- Theophrastus, quoted, 58, 262
- Thorne, C. E., 57, 90, 100, 121
- Tiling, 123-124
- Timothy, 46, 73, 86, 93, 192, 194, 195, 196, 197 *f.*, 345, 367
- Tobacco, 106, 107, 110, 218, 242 *ff.*, 266; as farm crop, 242; classes and types of, 243; cultural methods, 243-244; cigar leaf, 244-245; manufacturing type, 245-246; export type, 246; soil depletion, 246; root rot of, 291; used for destruction of insects, 316
- Tomatoes, 218, 288
- Tschermak, Erich, 14
- Tuberculosis, 288
- Turkeys, 310. *See also* Poultry
- Turnips, 9, 38, 231
- Ulbricht, T. C., 455
- United Kingdom, oats in, 169
- United States, the, consumption of sugar in, 236; sugar cane in, 237; forests in, 279-281; dairying in, 353;

- beef cattle in, 381; development of sheep in, 410-411; origin of poultry breeds in, 419
- Utah, alfalfa in, 210; sugar beets in, 237
- Van Slyke, L. L., 100, 114
- Varro, quoted, 82
- Vergil, quoted, 1, 8, 72, 353
- Vetch, 220, 405
- Virginia, tobacco in, 242
- Vivian, A., 57, 71, 81, 90, 100, 114
- Voorhees, E. B., 90, 114, 230
- Walnuts, 63, 281
- Warburton, C. W., 176, 203
- Waring, G. E., 132
- Warren, G. F., 121
- Washington, wheat in, 161; vetch in, 220
- Waste of soil, 82-83
- Water motor, 449
- Water in soil, 64-66
- Waugh, F. A., 277
- Weeds (Appendix L), xviii-xxiii
- West Virginia, tobacco in, 245
- Wheat, 2-3, 5, 8, 9, 10-11, 13-14, 15, 24, 33, 38, 60, 86, 106, 125, 156 *ff.*, 218, 327, 366, 402, 404, 427, 429; water drawn from soil by, 29; food used by, 73; in rotation, 86; history of, 156; classes of, 157; districts, 158-161; plowing for, 161-164; kind of seed to sow, 165; seeding, 165-166; pasturing, 167; harvesting, 168; used as a nurse crop, 196, 208; smuts of, 293-294; rusts of, 295-296
- Wheat and dry farming, 130-131
- Wheat-heading and threshing machine, 3
- Wheat middlings, 427
- Wheat shorts, 402
- Wheat straw, digestibility of, 324
- Wheeler, H. J., 100
- White clover, 405
- White grubs, 310
- Whitson and Walston, 121
- Wickson, E. J., 277
- Widtsoe, John A., 132
- Wilson, A. D., 203
- Wilt of cotton, 287
- Windmill, the, 449
- Wing, H. H., 380
- Wing, Joseph E., 203, 417
- Wireworms, 310
- Wisconsin, corn in, 140, 142; wheat in, 160; oats in, 169; barley in, 171; rye in, 172; alfalfa in, 210; tobacco in, 244
- Wood ashes, 106
- Wood crop, the, 279 *ff.*; importance of, 279; the forest industry, 279-280; forests of the United States, 280-281; forests as modifiers of climate, 282; forests as preventers of floods, 282; state and national ownership, 282-284; farm wood lots, 284
- Woodsley, W. H., 247
- Wyoming, wheat in, 160

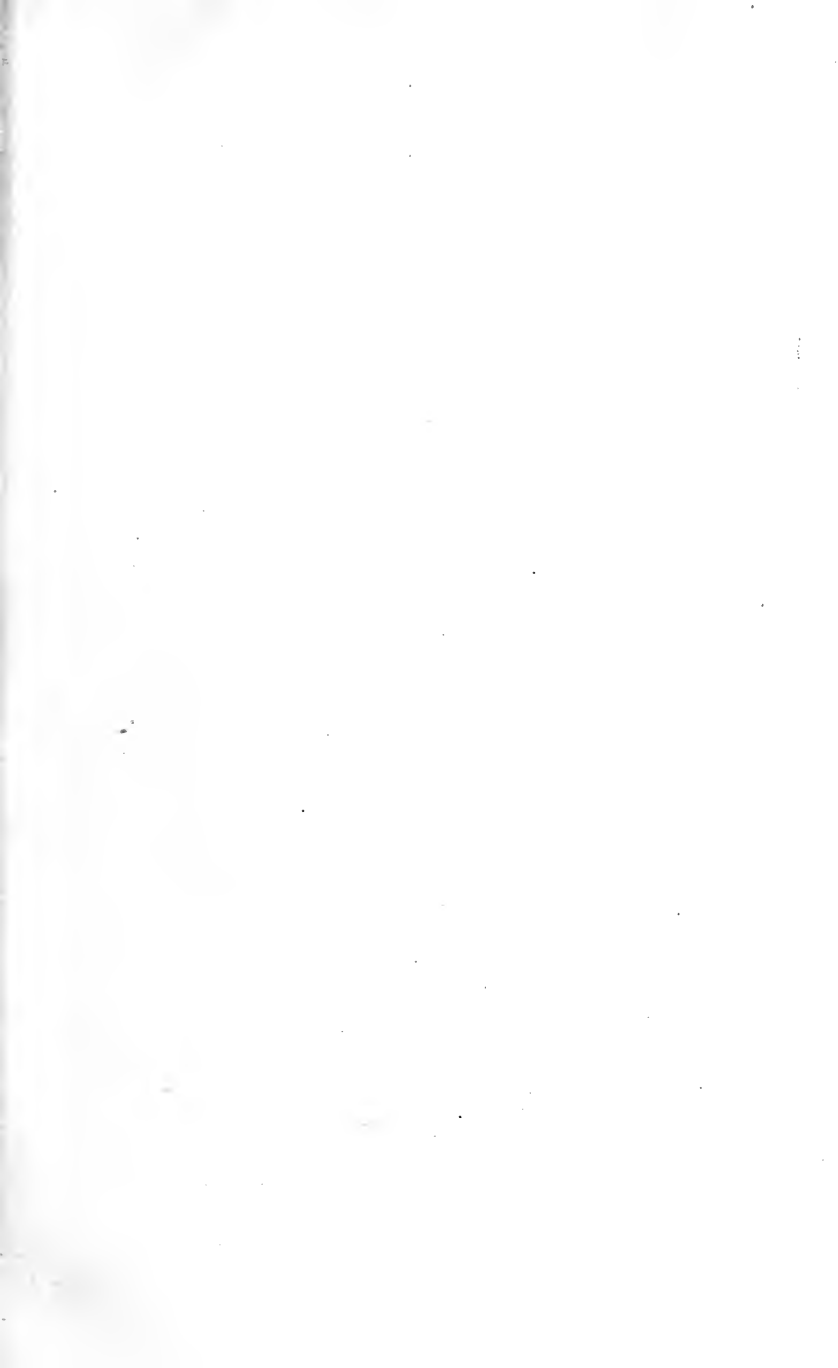

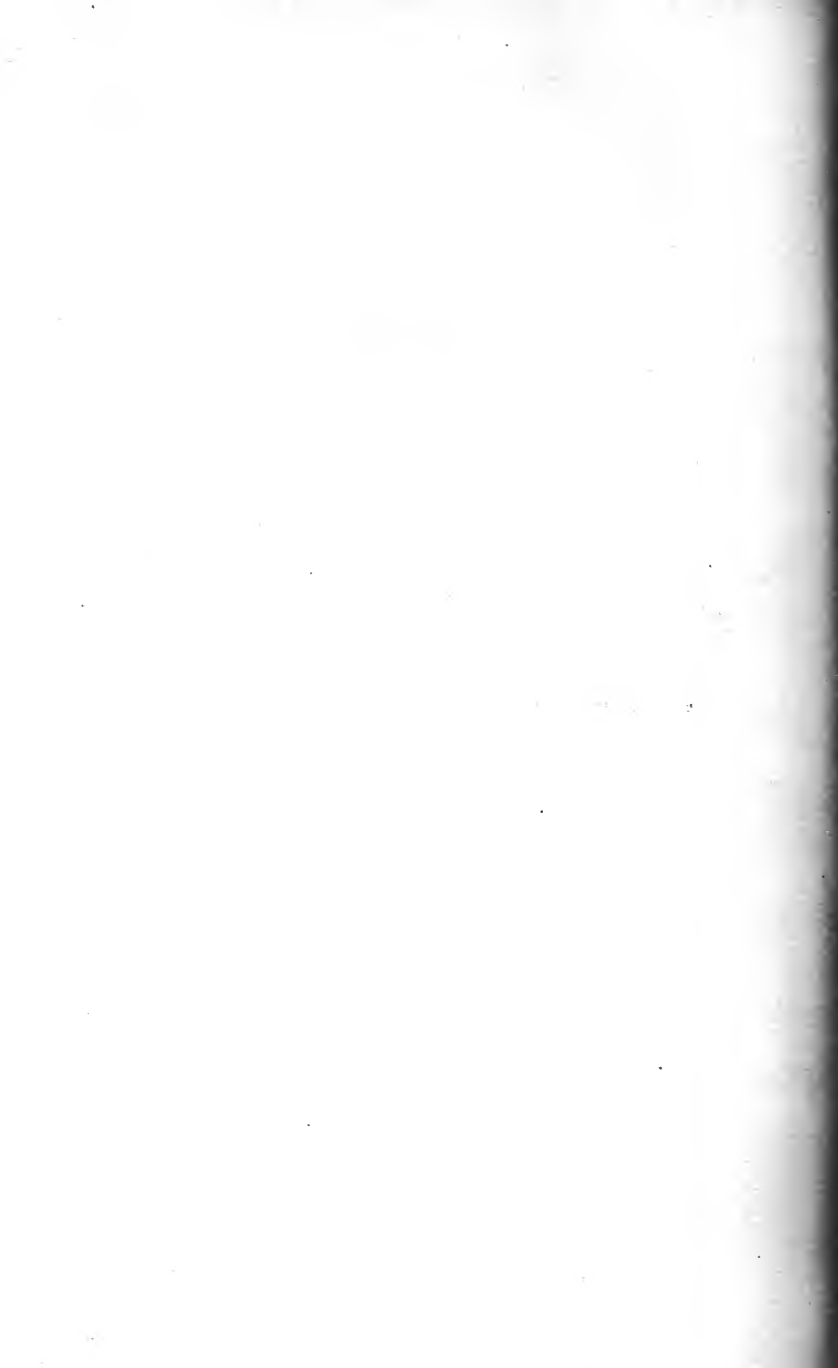

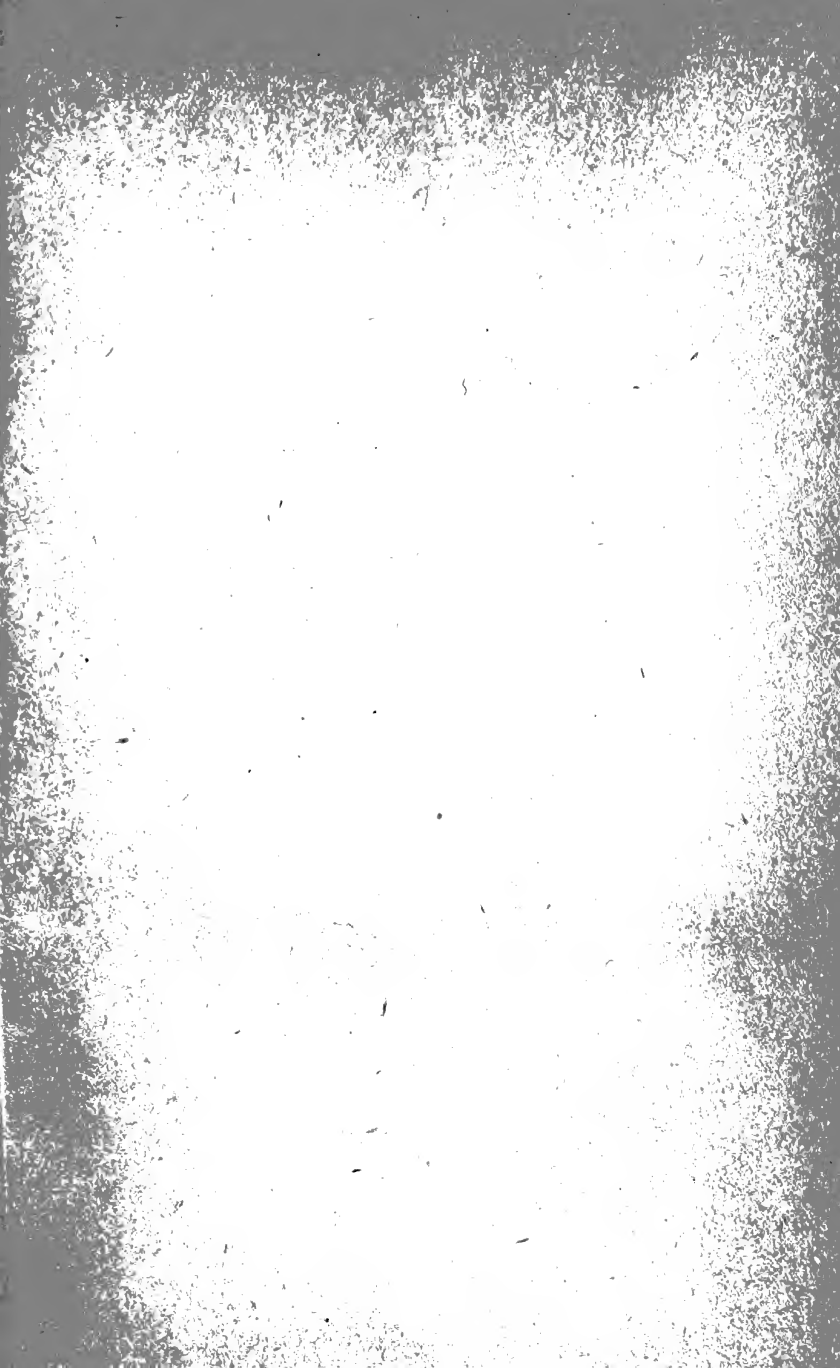

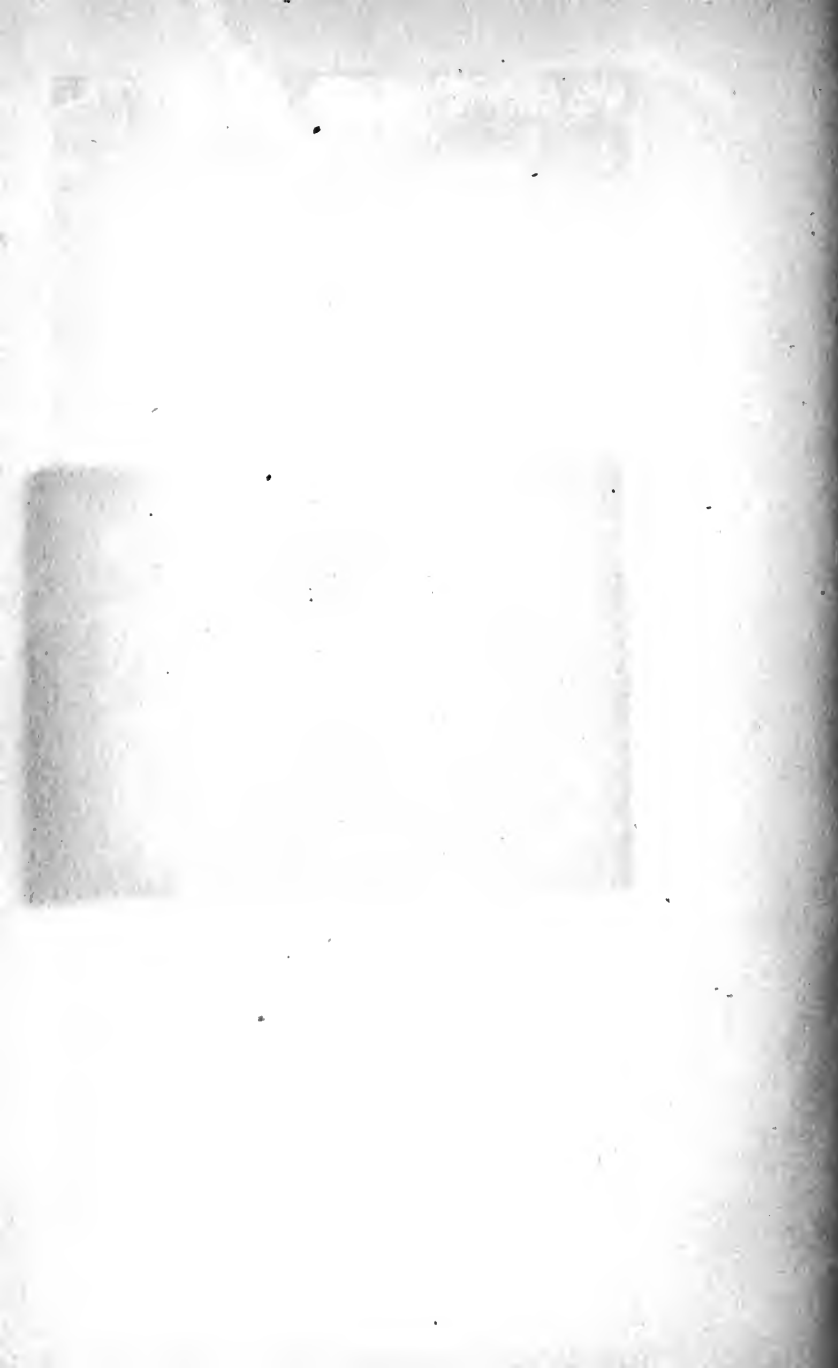



S495

M4a

**333896**

Watsone

UNIVERSITY OF CALIFORNIA LIBRARY

