

SF 487
.K315
Copy 1

THE ESSENTIALS
OF
POULTRY RAISING

B. F. KAUPP



THE JOHNSON PUBLISHING CO.
RICHMOND VIRGINIA



Class SF487

Book .K315

Copyright N^o _____

COPYRIGHT DEPOSIT.



THE ESSENTIALS
OF
POULTRY RAISING

A TEXTBOOK FOR VOCATIONAL
AGRICULTURAL SCHOOLS

BY

B. F. KAUPP, B. S., M. S.

Professor Poultry Science, North Carolina Agricultural College



B. F. JOHNSON PUBLISHING CO.
RICHMOND, VIRGINIA

SF487
K315

Copyright, 1920,
By
B. F. JOHNSON PUBLISHING COMPANY

All Rights Reserved.

APR 14 1920

©Cl.A566488

no 1

EMS 15 Apr. 1920

FOREWORD

It is to meet the need of vocational agricultural secondary schools that this effort has been put forth to arrange in sequence those facts that the student needs in elementary poultry work. It is intended that these chapters shall be given in the classroom at the time of the year when suitable material will be available for the corresponding laboratory practice periods, though each chapter, being complete within itself, allows the assignment of the chapters in any order the teacher may choose. Working diagrams and photographs are provided for these practice periods, in order that the work of the teacher may be lightened.

Suggestions are made for library references for the laboratory periods which should accompany each lesson, and outline suggestions are given for two major projects, with two minor projects that dovetail together. There is also included a school demonstration to show that crossbreeding for two generations means scrubs. In addition to the twenty-two lessons and the twelve laboratory exercises accompanying them, thirty-two additional laboratory exercises are suggested, together with fourteen skills.

Under the above arrangement, it is believed that a complete course, so far as it goes, can be given in twenty-five periods only and that, by additional laboratory exercises and skills, these hours can be stretched to fifty or even seventy-five or a hundred periods, should it be the desire of the teacher to do so. Many of the laboratory exercises will extend over at least two periods if the work is completed satisfactorily: for example, the construction of the combination sitting and brooding coop.

I wish to thank the following persons for valuable sugges-

tions and advice in arranging the subject matter of this book: the men of the Department of Vocational Education of the North Carolina State College of Agriculture; the two classes of Farm Life School principals who studied at State College during the summer of 1919, and Professors L. E. Cook, W. D. Barbee, and O. B. Jones.

West Raleigh, N. C.

B. F. KAUPP.

CONTENTS

CHAPTER.	PAGE.
I. The History of Poultry and the Poultry Industry	9
II. The External Structure of the Fowl!	14
III. How Poultry Is Classified	17
IV. How to Select Birds for Breeding	27
V. How to Select Laying Hens	34
VI. The Necessity of Air and How to Ventilate the Poultry House	38
VII. To Remodel a Poultry House or to Make a New House	42
VIII. The Construction of Poultry House Equipment	48
IX. Fences and Yarding Chickens	54
X. Contagious Diseases of Poultry Appearing in Fall	58
XI. The Digestive Tract of the Fowl and Its Function	62
XII. Poultry Feeds and Their Values	65
XIII. Feeding Layers and Breeders	71
XIV. Candling and Grading Market Eggs	75
XV. Construction of the Combination Sitting and Brooding Coop	82
XVI. Selecting Eggs for Hatching and Setting a Hen	85
XVII. Artificial Incubating and Brooding	89
XVIII. Feeding Chicks, Goslings, Ducklings, and Poults	96
XIX. Fattening Poultry and Shipping Poultry Products	102
XX. Diarrhea in Poultry	106
XXI. Mites, Lice, Scaly Leg, and Fleas of Poultry	110
XXII. Worms Infesting Poultry	113
XXIII. Poultry as an Important Enterprise on the Farm	116
XXIV. Suggestions for Projects and Laboratory Exercises	121
XXV. A Few of the More Common Questions That May Be Used for Study and Review	125

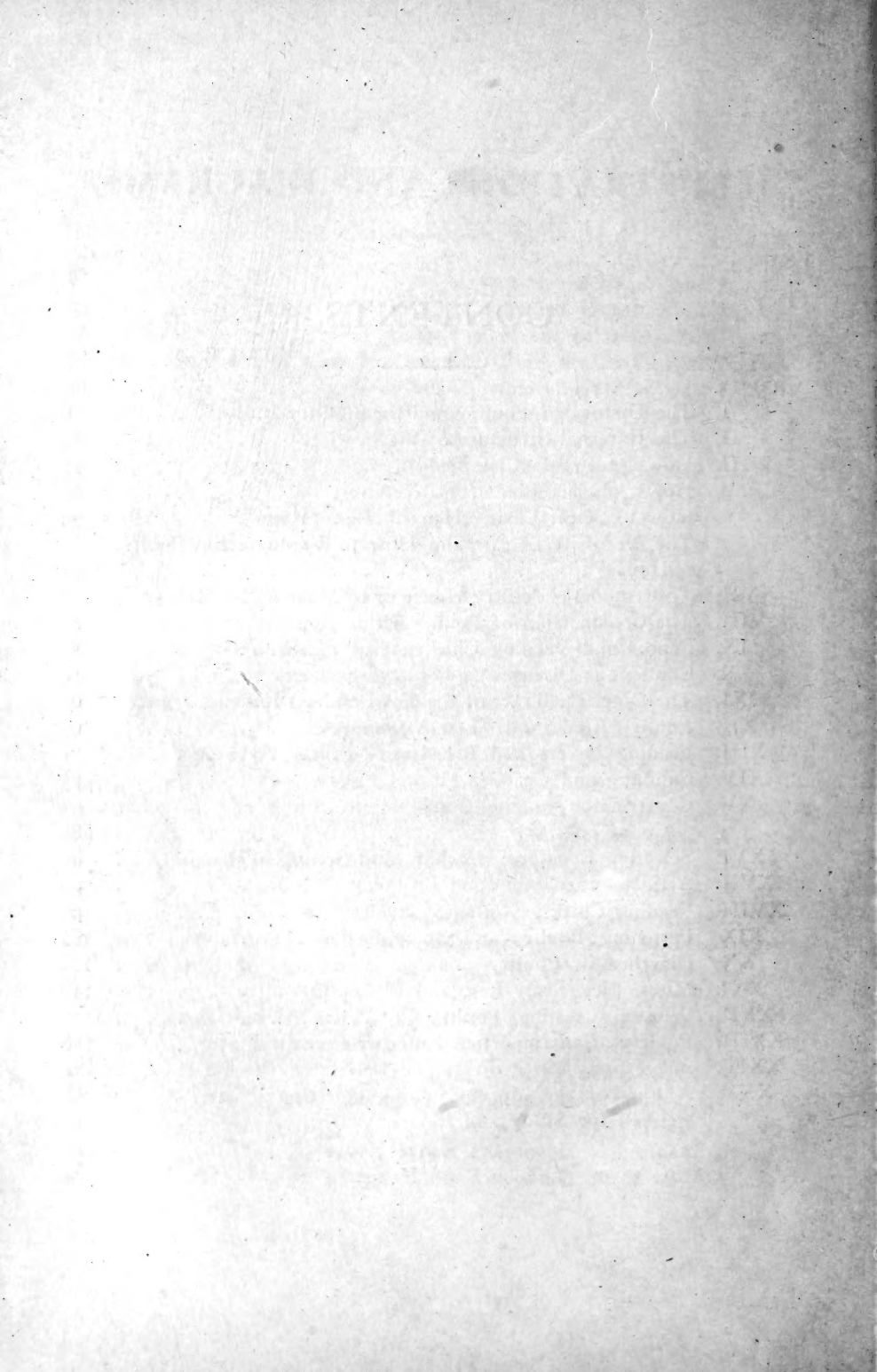

ILLUSTRATIONS AND DIAGRAMS

FIGURES.	PAGE.
1. A Bronze Turkey Hen	8
2. A Cold Storage for Eggs and Dressed Poultry	12
3. The Sections of the Male Fowl	15
4. A Buff Plymouth Rock Cockerel and the Cup He Won	18
5. A Pair of Indian Runner Ducks	19
6. A Pen of Prize-Winning Light Brahmas	20
7. A Barred Plymouth Rock Hen	21
8. A Barred Plymouth Rock Male	22
9. A Dark Cornish Hen	23
10. A Two-Year-Old White Plymouth Rock Male	24
11. A First Prize Winning Single-Comb Rhode Island Red Male Bird	25
12. A North Carolina State Poultry Club Member's Flock of Single-Comb Rhode Island Reds	26
13. A Graph Illustrating Increase in Egg Production	28
14. A Utility Single-Comb White Leghorn	29
15. A Cull Single-Comb White Leghorn, Showing Weak Vigor	30
16. Two Years from Pure Bred to Mongrels	33
17-18. Diagrams of an Open-Front Poultry House, Showing Currents of Air	39-40
19. Diagrams of a Poultry House	46-47
20. A Grain Storage Bin	49
21. End of a Grain Storage Bin and of a Dry Mash Hopper	50
22. Diagram of Nests	51
23. The Droppings Box and Scrape	52
24. The Digestive and Respiratory Tracts of a Fowl	63
25. A Graph Showing the Average Percentage of Eggs to Expect	76
26. A Graph Showing the Fluctuation of the Price of Eggs	77
27. A Graph Showing Egg Production Necessary to Pay	78
28. A Home-Made Candler	79
29-30. The Combination Sitting and Brooding Coop	83-84
31-32. An Oil-Burning Incubator	90-91
33. A Diagram of Hover and Range House	93-94
34. A View of an Outdoor Mash Hopper	99

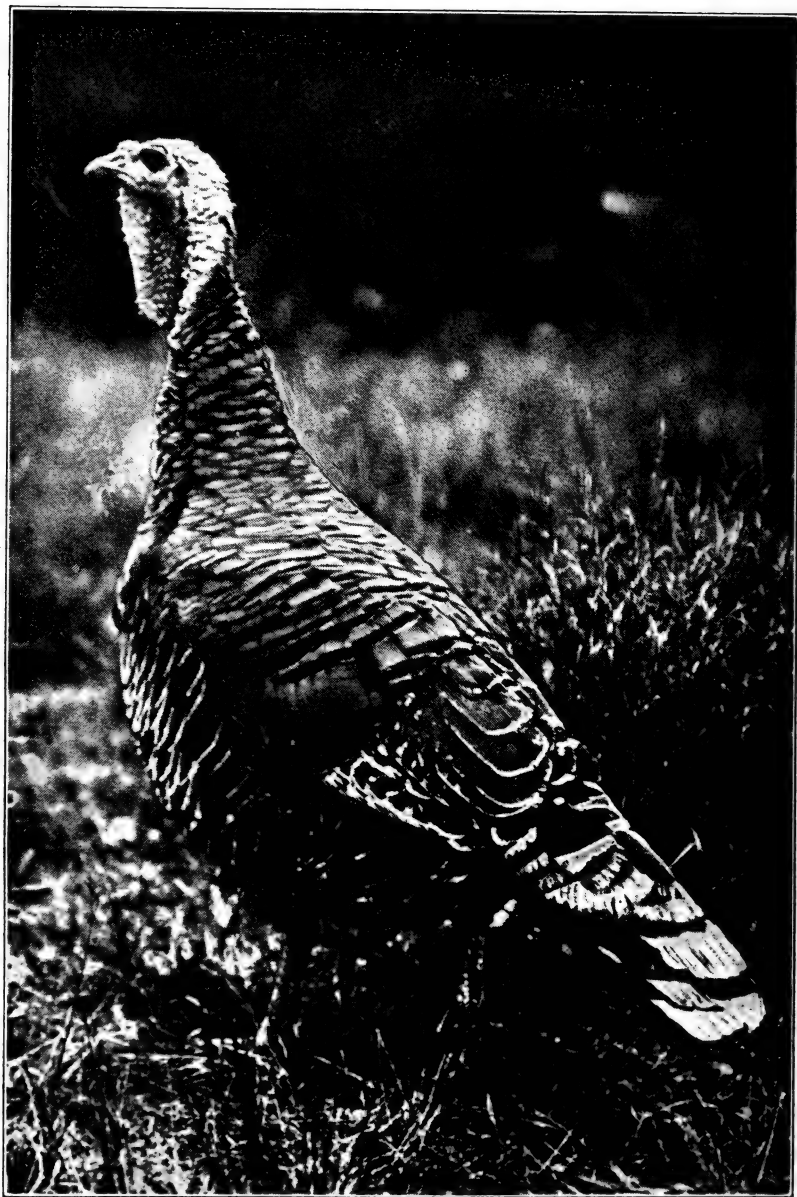

Fig. 1. A BRONZE TURKEY HEN.
(Bred by Miss Mahaney, Maine.)

Turkeys are raised principally for Thanksgiving and Christmas dinners.

The Essentials of Poultry Raising

CHAPTER I

THE HISTORY OF POULTRY AND THE POULTRY INDUSTRY

1. **The Origin of the Fowl.** From biblical history we learn that fowls are probably as old as man himself. The modern fowl originated from the *Galus Bankiva*, which apparently was first observed on the Isle of Banca near Borneo.

2. **Kinds of Fowls.** At the present time there are several hundred kinds of fowls, varying in size from the bantam, weighing but a few ounces, to the large Brahma, weighing twelve to fourteen pounds. In addition to those fowls commonly called chickens, there are water fowls, such as geese and ducks, and turkeys, guineas, and pigeons, all of which are raised and kept to furnish people with food in the form of eggs and meat.

3. **Poultry in America.** There have been developed in America many breeds of fowls, such as the Rhode Island Red, Wyandotte, and Plymouth Rock. America is the home of the turkey and of the Cayuga duck.

4. **Purposes for Which Poultry Is Kept in America.** In America there are three kinds of poultry keepers, as follows: first, farmers who keep small flocks for both eggs and meat; second, city people who keep a few hens on the back lot for eggs and occasionally for meat as well; and, third, the commercial poultryman who keeps hens for the production of eggs for market.

5. **Magnitude of the Poultry Industry.** The poultry products in the United States amount to over a billion dollars annually.

6. How the Surplus Eggs Are Marketed. Eggs are sold directly to the consumer by the producer on the town lot or the farm, or by the commercial poultryman. They are sold to stores or traded for groceries or dry goods for the family, and the grocer in turn sells them to the consumer or to the city commission man in case lots. The grocer also sells to hotels and restaurants as well as to commission men. In many communities, clubs are formed and a business agent is selected; the eggs are collected at one point, graded, placed in thirty dozen cases, and sold to city commission men or directly to consumers' circles in the cities.

7. Fattening Establishments for Poultry. Throughout the United States there are many centers where poultry fattening plants, with capacities of 10,000 to 50,000 fowls, receive young chickens, mostly cockerels, weighing from two to three pounds each. These young birds are fed a fattening mixture or feed for a period of fourteen days and are then killed, dressed, placed in cold storage, and sold according to grade. Many car lots and case lots are shipped to different points, especially to the large cities. In many of these establishments the birds are fed ground feed with buttermilk. The milk gives the birds an excellent flavor, and in markets like New York city such birds, when dressed, bring five cents per pound more than those not milk fed.

8. How Fattened Poultry Is Marketed. In many of the larger towns there are commission merchants who buy eggs and poultry and ship them to the city markets. In some of these towns the large packing establishments, such as Armour and Company and Swift and Company, have buying offices. From these places the poultry and eggs are sent to the packing houses, where the eggs are stored and the fowls are fattened, slaughtered, and kept in coolers till times of scarcity.

9. Storage for Dressed Poultry and Eggs. The bulk of the eggs are laid by the hens in the months between February and

July, and most of the young fowls for market are raised in the months from April to September. Some means of preserving a part of this food from the season of plenty to the season of scarcity is essential. To meet this need, large storage buildings have been constructed of brick or cement and have been provided with rooms that are kept at the proper temperature for preserving eggs or dressed poultry for several months.

10. Eggs in Car Lots. Buyers of large quantities of eggs in large cities ship eggs in car lots. These cars hold 400 (or more) thirty-dozen cases of eggs. The cars are refrigerated, with ice compartments at each end of the car which are kept filled with ice. The cars are shipped to the large northern cities, such as New York and Boston. A string of cars containing eggs and dressed poultry is constantly going from the West to the East over the regular railway routes. Thus there are local commission merchants who buy eggs from the producer in dozen lots, larger city commission merchants who buy only in thirty-dozen case lots, and still larger dealers who buy eggs only in car lots.

11. Turkey Production. In many of the middle western states large numbers of turkeys are raised. In some places, especially in Texas, they are driven to market on foot. Turkeys are raised principally for holiday dinners, especially Thanksgiving and Christmas.

12. Duck Production. In many places large numbers of ducks, principally of the White Pekin variety, are raised for broilers. This is a very profitable venture on Long Island, where over one and a half million ducks are raised every year for the Jewish trade of New York city.

13. Capon Production. Capons are produced quite extensively in many sections. The soft "roasters" of the south shore of Massachusetts and the Philadelphia capons, produced by the farmers of New Jersey, have become especially well known.

14. The Magnitude of the Poultry Industry. In 1912 the



Fig. 2. The cold storage is to the nation what the refrigerator is to the family, a means of preserving food from a time of plenty to a time of scarcity, thus equalizing distribution throughout the year.

poultry products of the United States were greater than the wheat or potato crop. They were greater than the total hog or mule production and equal to two-thirds of the hay crop, to 70 per cent of the value of all milk cows, and to 73 per cent of that of all other cattle.

15. **Poultry in Other Countries.** Great Britain has been one of the leading countries in the production of poultry. She has developed many useful breeds: the Dark Cornish, the Orpingtons, and the Sussex. South Africa, Australia, and New Zealand are well advanced in poultry raising. The blood of many of the best breeds is traced to China.

16. **Egg Production Records.** Apparently Australia holds the world's record for high egg production. An Orpington hen laid 334 eggs in one year. America has produced a Single-Comb White Leghorn, Lady Eglantine, who laid 314 eggs in 365 days.

CHAPTER II

THE EXTERNAL STRUCTURE OF THE FOWL

Note to Teacher: The student is to mount a feather from each part of the plumage of a male bird.

17. The bird is divided into the following principal parts: head, neck, back, saddle, tail, wing, breast, and body.

The **head** is divided into comb, face, wattles, eye, beak. The comb may be single comb, rose comb, v-shaped comb, or pea comb. The single comb has a base which attaches the comb to the top of the head. It is provided with a blade and small spikes projecting upward from the comb. Some breeds of fowls have five spikes, others six. The rose comb has a fleshy body attached to the top of the head. It has a flat top, provided with many small spikes projecting upward and a large spike projecting backward. The v-shaped comb, as the name implies, is shaped like the letter *v*. The pea comb consists of three small single combs arranged side by side, with the two outer combs low and the middle one slightly above the other two. The face is the unfeathered part at the side of the head. The wattles are the two flat, leaf-like structures hanging pendant from the under portion of the lower jaw or mandible. The eyes and ears are located on the side of the head in the region of the face. The ear lobe is a fleshy mass extending downward from the ear opening. It is smooth and its color is either red or white, according to the breed of the fowl. The beak consists of an upper part, or upper mandible, and a lower part, or lower mandible.

18. The **neck** is divided into the neck hackle and the cape. The cape is the lower and outer edge of the neck hackle and resembles a cape.

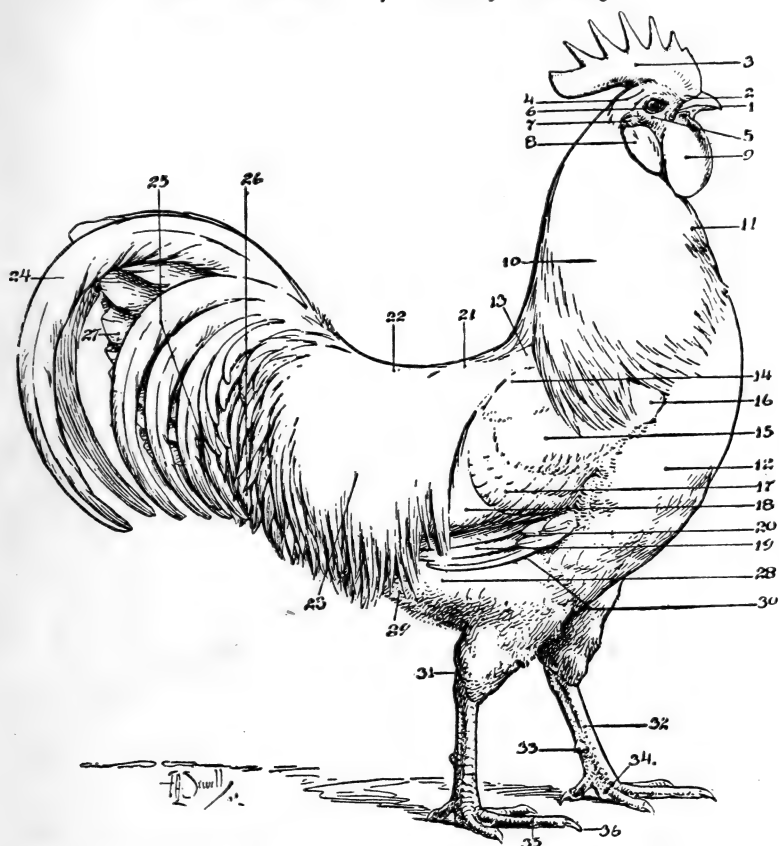

Fig. 3. THE SECTIONS OF THE MALE FOWL.

1, beak; 2, nostril; 3, comb; 4, crest of head; 5, face; 6, eye; 7, ear; 8, ear-lobe; 9, wattle; 10, hackle, neck; 11, front of hackle; 12, breast; 13, cape; 14, shoulder; 15, wing bow; 16, wing front; 17, wing coverts, wing bar; 18, secondaries, wing bay; 19, primaries, flights; 20, primary coverts; 21, back; 22, saddle; 23, saddle feathers; 24, sickles; 25, smaller sickles; 26, tail coverts; 27, main tail feathers; 28, body feathers; 29, fluff; 30, thigh; 31, hock; 32, shank; 33, spur; 34, ball of foot; 35, toe; 36, toe nail. (R. P. J.)

19. The **back** is that portion between the hackle and the saddle.

20. The **saddle** is located in that portion between the back and the tail. In the male it is provided with long flowing hackle feathers somewhat resembling the neck hackle.

21. The **tail** is divided into the main tail, sickle, and covert feathers. The main tail feathers consist of a row of stiff large feathers, arranged in v-shape, just under the sickle and covert feathers. The sickle feathers are the large curved feathers extending over the top of the tail. At the base of the sickle and main tail feathers there are smaller feathers that cover the base of the first two.

22. The **wing** is divided into the following parts: front, bow, bar, secondaries, primaries, bay, and coverts. The wing bow is the upper and outer third of the wing when folded and looks like a bow. The wing bar is located just back of the wing bow and in some breeds makes a distinct bar. The secondaries are the large stiff feathers located on the part of the wing nearest the body, and the ten large stiff feathers on the outer end of the wing are the flight or primary feathers. In some birds, when the wing is folded, there is noted a three-cornered white space at the back portion of the folded wing: this is called the wing bay. The flight coverts are small, stiff feathers which cover the roots of the flight feathers.

23. The front part of the bird below the cape or hackle is the **breast**.

24. The sides of the bird constitute the **body** proper, and the posterior part is occupied by the cushion or vent fluff.

25. The leg is divided into the thigh, knee, tibia or drum-stick, hock, shank, spur, foot, toes, and claws. The thigh is the femur or that region around the first bone of the leg. The knee is the first joint of the leg. The tibia or drum-stick is the second bone of the leg, sometimes incorrectly called the thigh. The hock is the second joint of the leg. The shank is the unfeathered portion of the leg or the bone below the hock. The spur is located on the inner and lower third of the shank and is best developed in the male bird. The foot is provided with four toes, three extending forward and one backward. Each toe has a claw.

CHAPTER III

HOW POULTRY IS CLASSIFIED *

Note to Teacher: The school flock and nearby pure-bred flocks should be visited for the purpose of studying breeds and varieties. Among the first things to be taught are the simple points whereby one differentiates between the breeds. Examples: The Wyandotte has a rose comb, while the Plymouth Rock has a single comb. An Orpington has a white beak and shanks, while the Plymouth Rock has a yellow beak and shanks. A Light Brahma has feathers on the shanks; the Columbian Wyandotte has bare shanks.

26. **National Poultry Organization.** American poultry fanciers have formed an association called the American Poultry Association. This association determines the breeds and varieties of fowls: which shall be recognized as pure-bred fowls and worthy of being called Standard Bred.

27. **American Standard of Perfection.** The American Poultry Association publishes a book called *The American Standard of Perfection*. This publication gives the classification of all breeds and varieties recognized by the American Poultry Association.

28. **Classification of Poultry.** In the classification of poultry the following terms are used: class, breed, and variety. Thus a Barred Plymouth Rock would be classified as follows:

Class	Breed	Variety
American	Plymouth Rock	Barred

29. **Class.** By class is meant the country in which the breed was developed. Example: the Plymouth Rock was developed

* For reference book as to details of Breeds and Varieties, see *The American Standard of Perfection*, published by the American Poultry Association.

For reference to History of Breeds, see *Poultry Culture Sanitation and Hygiene*, published by W. B. Saunders Co., Philadelphia, Pa.

in America, hence it is placed in the American class. The Dark Cornish was developed in England and therefore it is in the English class.

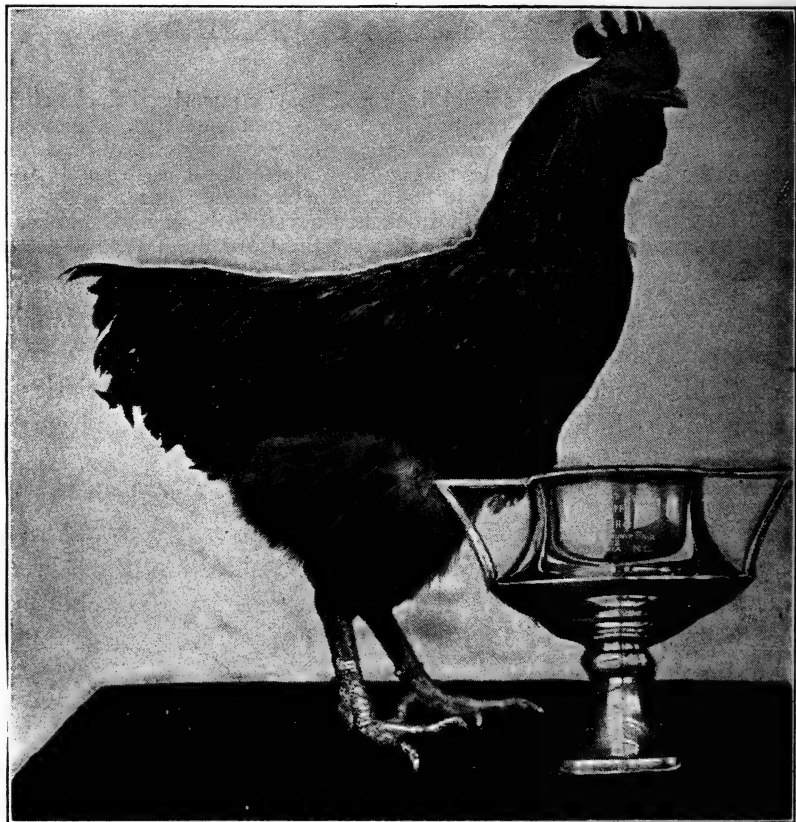

Fig. 4. A BUFF PLYMOUTH ROCK COCKEREL AND THE CUP HE WON.

(Bred at North Carolina State College plant.)

This bird is considered the best type and color.

30. **Breed.** By breed is meant the type, or shape, of the bird. Thus we speak of the Plymouth Rock type, or the Wyandotte type.

31. **Variety.** By variety is meant the feather pattern, or type of comb, or both. Example: the Single-Comb Rhode Island Red

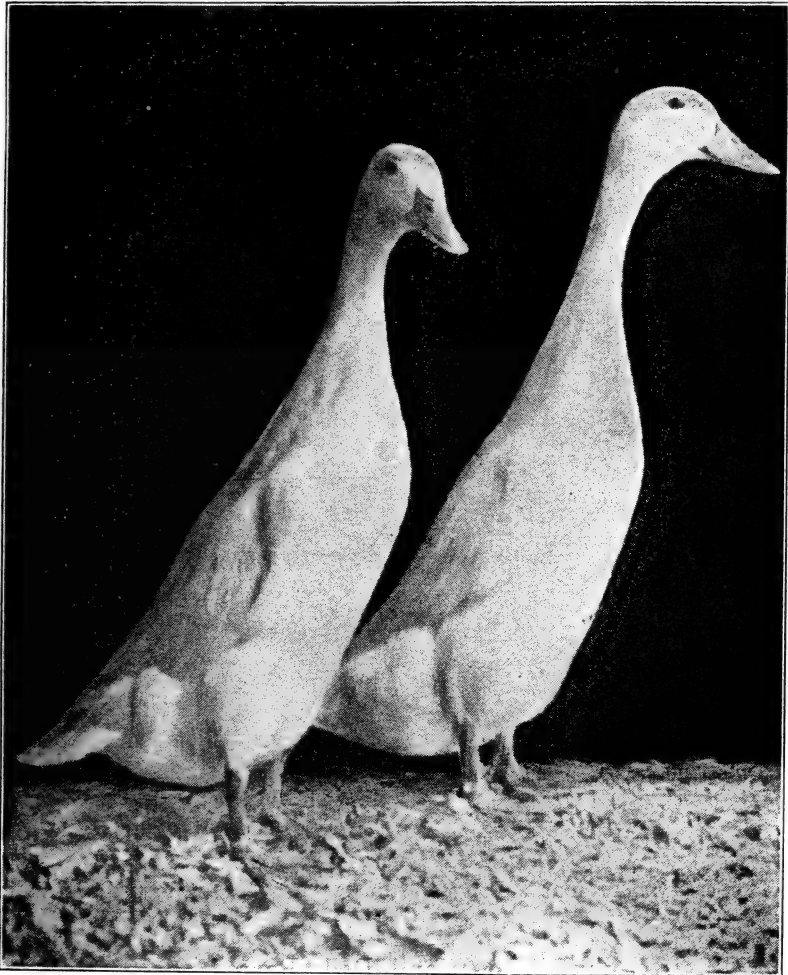

Fig. 5. A PAIR OF INDIAN RUNNER DUCKS.

(Bred by Patton, Charlotte, N. C.)

These ducks are raised principally for eggs.

and the Rose-Comb Rhode Island Red; the White Plymouth Rock, or the Barred Plymouth Rock.

32. **Type and Variety.** All varieties of the same breed have the same shape or type.

33. **Some of the Most Common Fowls.** Among the most common standard-bred fowls are the Single-Comb Rhode Island

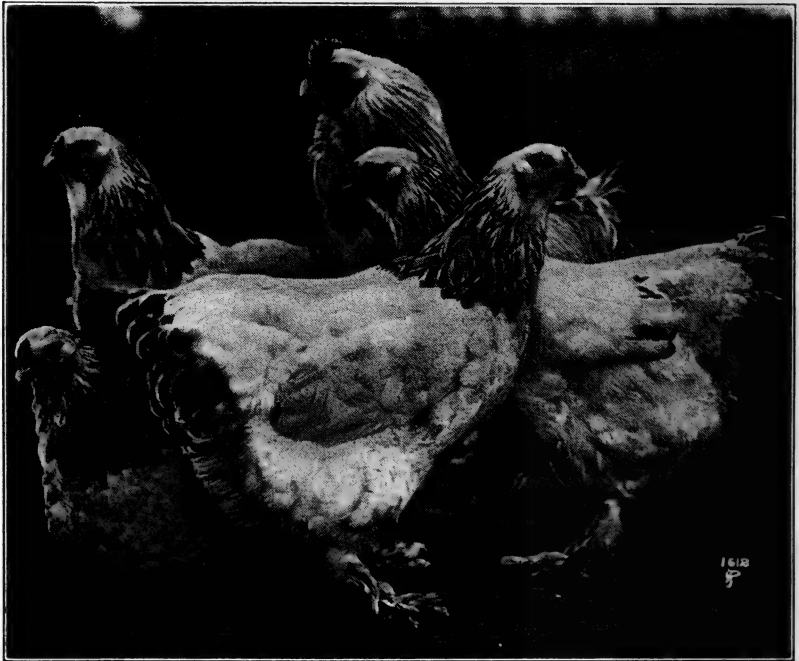

Fig. 6. A PEN OF PRIZE-WINNING LIGHT BRAHMAS.

(Bred by J. A. Pons, Asheville, N. C.)

The Light Brahmas belong to the Asiatic class. They are chiefly raised for meat.

Red, Rose-Comb Rhode Island Red, Barred Plymouth Rock, White Plymouth Rock, and White Wyandotte—all belonging to the American class. Of the English class there are the White Orpington, Buff Orpington, and Dark Cornish. The Single-

Comb White Leghorn and the Single-Comb Black Minorca belong to the Mediterranean class.

34. **Common Varieties of Turkeys.** One of the most common varieties of turkey is the Bronze. The male Bronze turkey at two years old should weigh thirty-six pounds, and the hen twenty pounds.

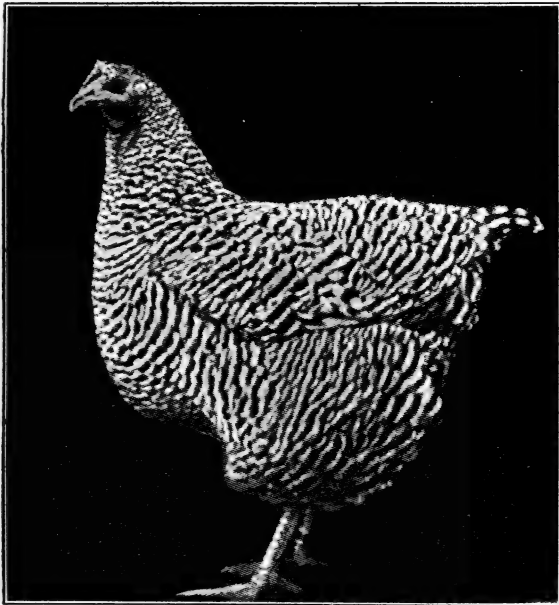

Fig. 7. A BARRED PLYMOUTH ROCK HEN.
(From *Poultry Culture, Sanitation and Hygiene.*)

The Plymouth Rocks belong to the general purpose or utility class of fowls. They are raised for both eggs and meat.

35. **Common Varieties of Geese.** One of the most common varieties of geese is the Toulouse. The gander should weigh twenty-five pounds, and the goose twenty pounds.

36. **Common Varieties of Ducks.** The White Pekin duck is raised most generally for meat. It has white feathers and a

yellow skin. It will reach a weight of about six pounds at ten weeks old. The young duck raised for market is called a broiler duck. The adult duck should weigh eight pounds and the adult drake nine pounds.

37. **Indian Runner Ducks.** Some varieties of ducks are kept

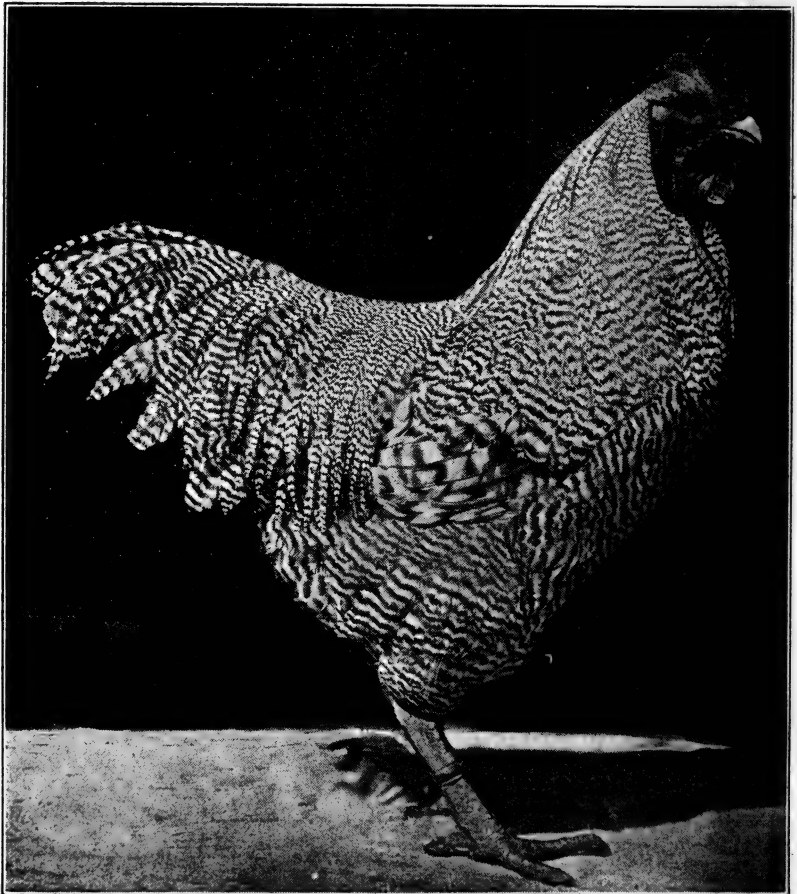

Fig. 8. A BARRED PLYMOUTH ROCK MALE.

(North Carolina Experiment Station.)

for egg production alone. The Indian Runner is the best egg producer, often laying close to 300 eggs in a single year. The Indian Runner drake should weigh four and one-half pounds at one year old, and the duck should weigh four pounds at one year old.

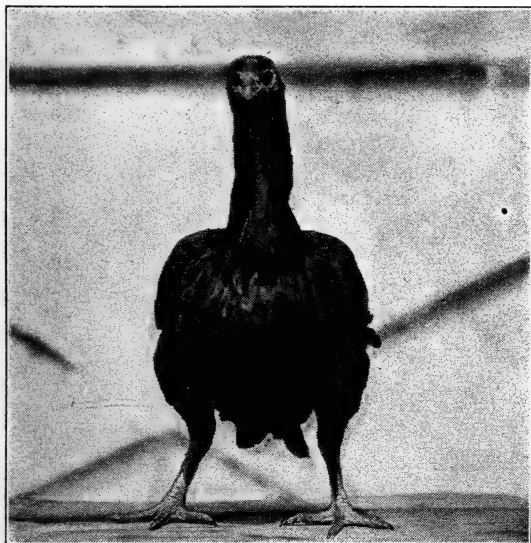

Fig. 9. A DARK CORNISH HEN.

(Bred by Ward, New Jersey.)

The Cornish is raised for meat. Note the full broad breast.

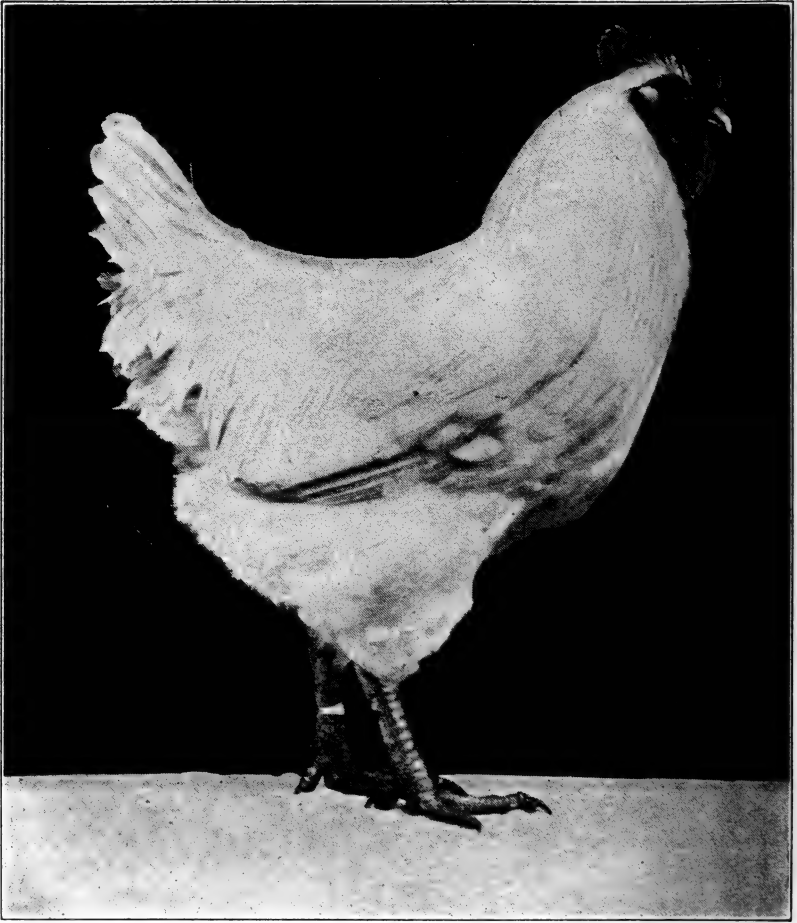

Fig. 10. A TWO-YEAR-OLD WHITE PLYMOUTH ROCK MALE.
(Bred by North Carolina State College.)
This is a utility bird.

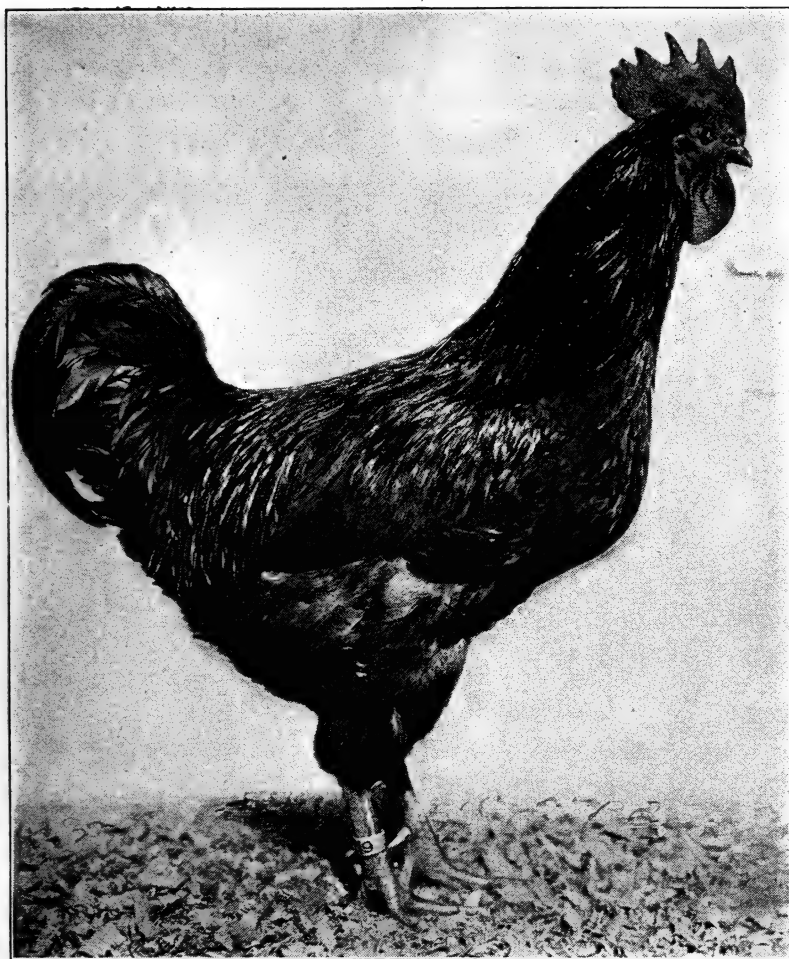

Fig. 11. A FIRST PRIZE WINNING SINGLE-COMB RHODE ISLAND MALE BIRD.

The Rhode Island Reds are one of the best utility breeds.



Fig. 12. A NORTH CAROLINA STATE POULTRY CLUB MEMBER'S FLOCK OF SINGLE-COMB RHODE ISLAND REDS.

Note the range house near a grove of forest trees. Trees furnish the essential shade needed for poultry. Green feed is also present for the birds, as well as bugs and insects.

CHAPTER IV

HOW TO SELECT BIRDS FOR BREEDING

Note to Teacher: The class should be taken to the school and nearby flocks to study constitutional vigor. As this study will come in the fall, the summer flocks should still be available.

38. **Purposes for Which Birds Are Kept.** Birds are kept for egg production, meat production, utility (general purposes), or for ornamental purposes.

39. **Egg Production.** The Single-Comb White Leghorn and the Single-Comb Black Minorca have been bred for high egg production and are among the most common breeds kept for the laying of eggs. The small body of the Single-Comb White Leghorn makes her the best and most economical egg producer. She will consume about ten pounds less feed for body maintenance than the birds of larger breeds. By proper selection, the larger breeds can also be bred up to very high egg production.

40. The power of high egg production is transmitted by both the male and female birds.

41. **Meat Production.** Some breeds are raised particularly for meat production because the quality of their meat is superior to that of other breeds. The Dark Cornish (Fig. 9) is one of the best of the meat breeds.

42. **Qualities of a Meat Fowl.** A meat fowl should have a deep keel, well fleshed over, making a round, plump breast. The skin should be soft and kid-glove-like to the touch.

43. **Utility Fowls.** Utility or general-purpose fowls are raised for both egg production and for meat. They are especially recommended for the farm, where both eggs and meat are desired in fairly large quantities. The Barred Plymouth Rock,

White Wyandotte, Rhode Island Red, and Buff Orpington are among the utility breeds.

44. **Ornamental Fowls.** Some fowls are raised largely because of their beauty. Among the ornamental fowls are the White-

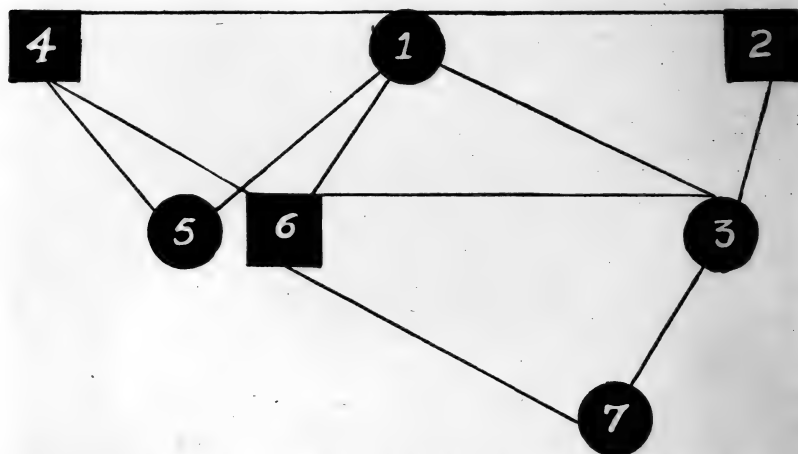

Fig. 13. A graph showing that a flock of common hens bred to common males produced pullets which laid approximately as many eggs as their mothers. The mothers (1) averaged 89 eggs per hen per year and their daughters from the common males (2) laid an average of 92 eggs each. These same mothers, bred to males that were from high egg producing hens for many generations (4), produced pullets that laid an average of 135 eggs per hen per year (5), or an increase of 35 per cent. This was brought about by the high egg production males. Brothers of these pullets (6) were bred to the common pullets from the first mating (3), and the pullets (7) from this mating laid an average of 122 eggs per hen per year, or an increase of 24 per cent in egg production. This lesson tells us that high egg production is transmitted by the male to his daughters and that the male also transmits high egg production to his sons and his sons to their daughters. (North Carolina Experiment Station.)

Crested Black Polish and the Japanese Bantams. The other Bantams are placed by some authorities among the ornamental fowls.

45. **Selection of the Male Bird for Breeding.** The male should possess all the characteristics of his breed and variety and should have an abundance of vitality.

46. Indications of Vigor. The crow of the male should be strong and clear, his movements active, his attention to the hens marked, and his comb and wattles well-developed. Red

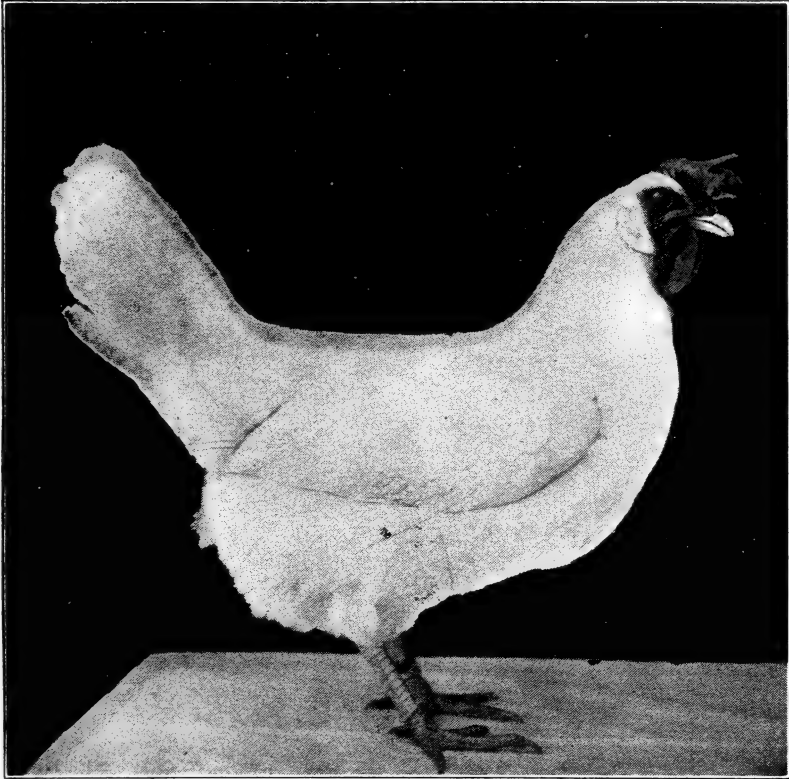

Fig. 14. A utility Single-Comb White Leghorn. This bird is of good constitutional vigor. Note well-developed head, comb, wattles, ear lobe, body, and the bright eye. This bird laid 223 eggs in one year. (North Carolina Experiment Station.)

comb and wattles and a readiness to banter and to crow at the sight of a new male are indications of health.

47. Selection of the Hen for Breeding. The hen should show the characteristics of her sex, with a refinement of the head and body not noted in the male,

48. **Indications of Health and Vigor.** The hen should be industrious. She should be scratching, foraging, and singing a considerable part of the time. A red comb, face, and wattles, and a marked happiness indicate health.

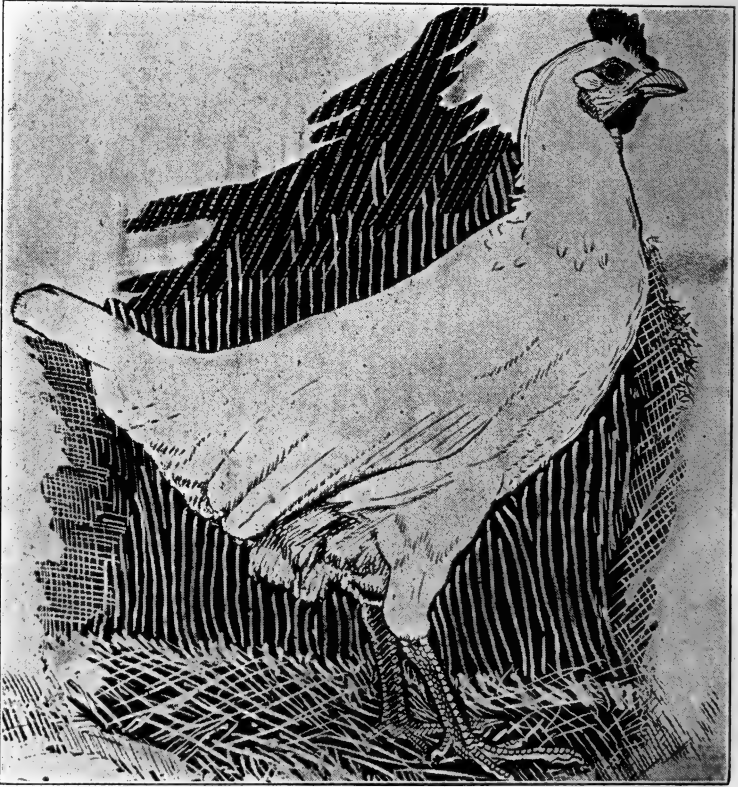

Fig. 15. A cull Single-Comb White Leghorn, showing weak constitutional vigor. This hen laid 36 eggs in one year. Note lack of development of the head, comb, wattles, ear lobe, body, and the dull eye. (Cornell.)

49. **Age of Breeders.** Select only mature birds for breeding. Birds should be up to standard weight.

50. **Age for Mating.** It is preferable to breed from birds that

are more than a year old. If pullets or cockerels must be bred from, it is preferable to mate the old male to pullets and the young male to hens. If pullets and cockerels must be mated together, they should be mature, that is, hatched early.

51. Objects of Poultry Breeding on the Farm. The objects of breeding poultry on the farm are: first, to bring a flock of mixed breeding up to a level with the best individuals of that flock, and, second, to fix certain characteristics, such as large egg production. In breeding poultry we wish to fix the following characteristics: constitutional vigor, high fertility, high egg production, early maturity, besides other characteristics which the breeder may desire, such as a particular feather pattern.

52. Lack of Constitutional Vigor. The lack of constitutional vigor is indicated by lack of proper development of the head, comb, wattles, ear lobes, and body. Such a bird is easily cowed by other birds.

53. Good Constitutional Vigor. Good constitutional vigor is shown by a well-developed head, comb, wattles, ear lobe, and body. The bird stands squarely on its feet. In males, vigor is noted by the crow, attentiveness to the hens, and readiness to banter and to fight when a strange male comes around. (Compare Figs. 14 and 15.)

54. Length of Time After Mating Fowls Before Saving Eggs for Hatching. If hens have not been running with male birds before being mated, eggs may be saved for hatching purposes at the end of six days. If the hens have been running with males before being mated, it will be necessary to wait twenty days before saving eggs for hatching.

55. Selecting Turkeys for Breeding. Select turkeys of good size. Turkeys for breeding should be mature, of good weight, and of good constitutional vigor. Do not breed from birds with deformed backs, crooked breasts, or wrytails.

56. Selecting Ducks for Breeding. The largest specimens should be selected. The drake is considered at his best the first

two years of his life. The duck should be more than two years old for breeding purposes.

57. How to Distinguish Sex of Ducks. The drake seldom quacks and has a harsh voice. The drakes are usually larger than the ducks and have a curled feather at the front and top part of the tail.

58. Selecting Geese for Breeding. The gander may be used the first season, but the goose should not be used as a breeder until she is one year old.

59. Number of Females to Mate to Each Male. Among the larger breeds of fowls ten to twelve hens may be mated to one male. Young males will take more females than old males. In the smaller breeds, such as the Leghorn, twelve to fifteen females may be given each male. One male turkey may be mated to as many as fifteen females. One gander may be mated to two or three geese. One drake may be mated to four or five ducks.

60. Results of Crossbreeding. Do not crossbreed, as the second generation will be scrubs. Scrubs do not produce eggs that are uniform in shape, color, and size, and the birds are never uniform in color or size. If a product is not of the best quality, the producer will not receive the highest market price for it. Study Fig. 16 for results of crossbreeding.

The first year a Single-Comb White Leghorn was mated with Light Brahma females and the progeny were uniform. The second year these birds were mated together and the progeny of this second breeding were nothing but scrubs, producing eggs and birds of different shapes and sizes. This always happens. Never crossbreed. Always breed pure-bred poultry; then your product will be uniform and you will receive the best prices.

Fig. 16. TWO YEARS FROM PURE BRED TO MONGRELS.

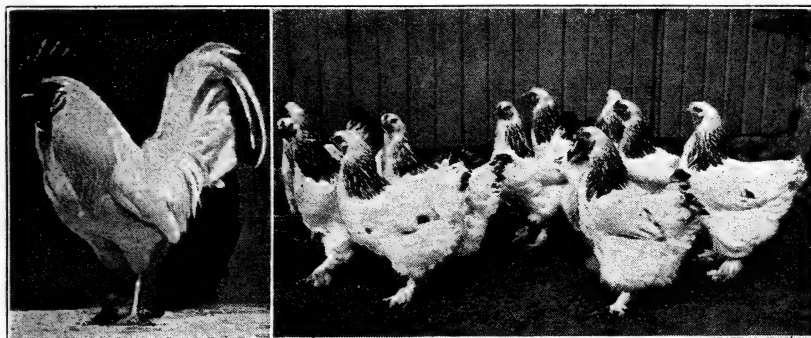

S. C. W. Leghorn.

The First Cross.

Light Brahma.

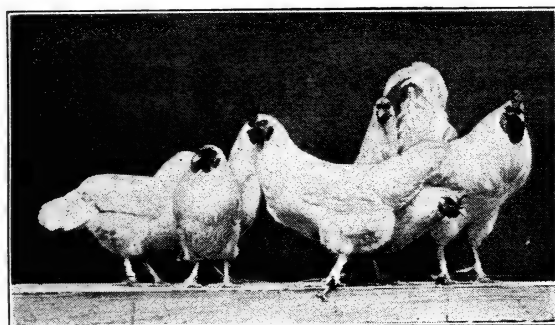

Result First Cross (F^1 Generation).

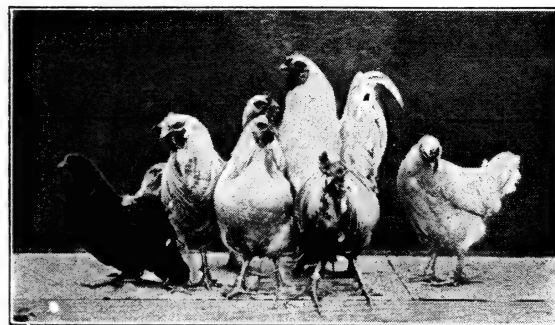

Result F^1 Generation Cross (F^2 Generation).

CHAPTER V

HOW TO SELECT LAYING HENS

Note to Teacher: The class should be taken to the school and nearby flocks to practise taking measurements and for observation of the other characteristics indicating good and poor layers. Allowance must also be made for fingerbreadths, as the standard fingerbreadth is based on the fingers of the average-sized man.

61. **When to Cull Hens.** Hens should be culled each year in July or August, or as soon thereafter as possible.

62. **Physical Condition of Laying Hens.** In order that a hen may lay well, she must have a sound body. The bird must be vigorous and healthy. Vigor and health are shown by a bright, clear eye, an active disposition, and a well-developed body.

63. **Physical Condition of Poor Laying Hens.** Poor laying hens are shy, while good layers are tame and easily handled. A poor laying hen goes to perch early. Her toe nails are long, indicating that she has not been scratching like the good layer. The poor layer usually is the last bird to leave the perch in the morning.

64. **Physical Defects.** Laying hens should be free from such physical defects as a crooked beak, excessively long toe nails, eyelids that overhang so that the bird cannot see well, scaly legs, or anything that would tend to keep the bird from getting an abundance of feed.

65. In the yellow-skinned birds, such as the Leghorn, Plymouth Rock, Rhode Island Red, and Wyandotte, the yellow color fades out as laying goes on. Skin tests cannot be carried on in birds with a white skin.

66. **Bleaching of Beak and Shanks.** In Leghorns the beak will be entirely bleached by the time the bird has laid thirty eggs. The shanks will be bleached out by the time the bird has laid sixty eggs.

67. Conditions of Vent. The vent of a laying hen is soft, flabby, large, moist, and white. In a non-laying hen the vent is hard, dry, small, and yellow.

68. Body Changes Due to Laying. As a hen comes into laying, the ovary, in which the yolk of the egg is formed, becomes very much enlarged. The oviduct, where the albumin or white of the egg is formed and where the shell is manufactured, likewise grows much larger. The intestines increase 30 to 40 per cent in length and bulk. All these increases in the bulk of the abdominal organs make changes in the bony relations necessary. The breast bone is drawn downward and its lateral processes are pushed downward and outward. The pelvic arches are widened.

69. Measurements. The distance between the posterior end of the breast bone and the laybones, or pubic bones, in a heavy laying hen is four or more fingers in breadth. If the measurement just referred to is four fingers in breadth, it indicates that the hen will, in all probability, lay over two hundred eggs and should be kept for a breeder. Allowance must be made for hens large in body, as the above measurements are estimates on White Leghorns. In a hen measuring four fingers in breadth between the posterior end of the breast bone and the laybones (pubic bones), the distance between the laybones, or pubic bones, will probably be three fingers in breadth. The measurement between the posterior end of the breast bone and the laybones is called *capacity*. The distance between the laybones is called *pubic span*.

70. Hens to Discard. Discard as layers all birds that measure less than three fingerbreadths in capacity and less than two fingerbreadths in pubic span.

71. Upward Tendency in Egg Production. Later, as more birds of the flock measure four fingers in breadth in capacity and three fingers in breadth in pubic span, discard all that do not measure more than three fingerbreadths in capacity and two fingerbreadths in pubic span.

72. External Sex Characteristics. The comb and wattles are sex organs.

73. Changes in External Sex Organs in Laying and in Non-Laying Hens. As a hen comes into laying, her comb grows congested, red, oily, very flexible, pliable, and soft. The wattles undergo similar changes. As the hen goes out of laying condition, the comb again shrinks, becomes dry, hard, covered with white scales, and stiff. On the day of laying, the comb will be hot to the touch.

74. The Abdomen of a Non-Laying Hen. In non-laying hens, the fat accumulates in the abdominal wall and the wall becomes hard to the touch.

75. The Abdomen in Laying Hens. As a hen comes into laying, the abdomen becomes soft and the skin velvety in texture.

76. Laying as a Pullet an Indication of Laying Qualities. The good laying hen begins to lay early as a pullet. Very heavy producers in the Leghorn breed will begin to lay at about five months of age. The poor layers begin very late, many of them not commencing until spring.

77. Molting as an Indication of Egg Production. Heavy layers do not go into full molt till late in the fall. Low producers will quit laying early, many of them as early as July and August—in fact, the latter part of June—and go into full molt.

78. Heavy Laying Hens Undergo Vacational Molt. A vacational molter casts a few feathers, during which time of molting she does not lay. She then begins laying, and growing feathers. After a few days she again stops laying for a few days, during which time she casts more feathers. She keeps up this process for a space of twenty-four weeks, undergoing a complete molt, and at the same time continues laying, though not so frequently as before she began her vacation.

79. Wing Molting. The wing molting is very characteristic in the vacational molters. There are ten primary feathers. Be-

tween the primary feathers and the secondary feathers is a short feather called the axillary feather. The first primary feather to molt is the feather next to the axillary feather. It takes six weeks to molt this feather and grow it again. Two additional weeks must be allowed for the molting and growing of each of the other primary feathers, making twenty-four weeks in all. When one feather is cast in one wing, it is noted that the corresponding feather in the other wing is also cast.

80. Culls in the Flock. In uncultured flocks, where breeding for high egg production has not been carried on, there will be at least 35 per cent of unprofitable fowls to be eliminated from the flock.

CHAPTER VI

THE NECESSITY OF AIR AND HOW TO VENTILATE THE POULTRY HOUSE

Note to Teacher: Visit a properly ventilated house and one not properly ventilated.

81. **Oxygen of the Air.** Air contains an element called oxygen. Oxygen is essential, for if air is withheld from the bird for a very few moments it will die.

82. **How the Bird Obtains Oxygen.** The bird obtains oxygen by breathing air into the lungs. The air passes through the nostrils, windpipe (trachea), lungs, and into the bladder-like structures extending from the lungs, called air sacs.

83. **How the Oxygen Is Taken Up.** The lungs and air sacs are lined with minute blood vessels in which blood circulates and takes up the oxygen from the air, carrying it to the tissues of the body where it is needed to maintain life.

84. **Carbon Dioxide from the Body.** In the performance of the vital processes within the body of the fowl, there is formed a poisonous gas called carbon dioxide. This carbon dioxide must be got rid of or the bird will die.

85. **How Carbon Dioxide Is Got Rid Of.** The blood absorbs the carbon dioxide and carries it to the lungs, where it is given off to the air. Thus the breathing in of air furnishes oxygen and the breathing out of air eliminates the carbon dioxide.

86. **Ventilation Required in Poultry Houses.** Poultry houses must be properly ventilated, so that a fresh supply of air will be always present and sunshine can find its way into the house.

87. **Methods of Ventilation.** There are two methods of ventilation: ventilation by diffusion and ventilation by draft.

88. **Ventilation by Diffusion.** Fig. 17 shows an open-front

house with no ventilator in the back. In this type of house the air passes in at the lower part of the open front and gradually diffuses back to the birds on the perch poles. The air surrounding the birds is warmer than that in the front of the building, and the heated, polluted air passes upward and out of the house at the upper part of the open front.

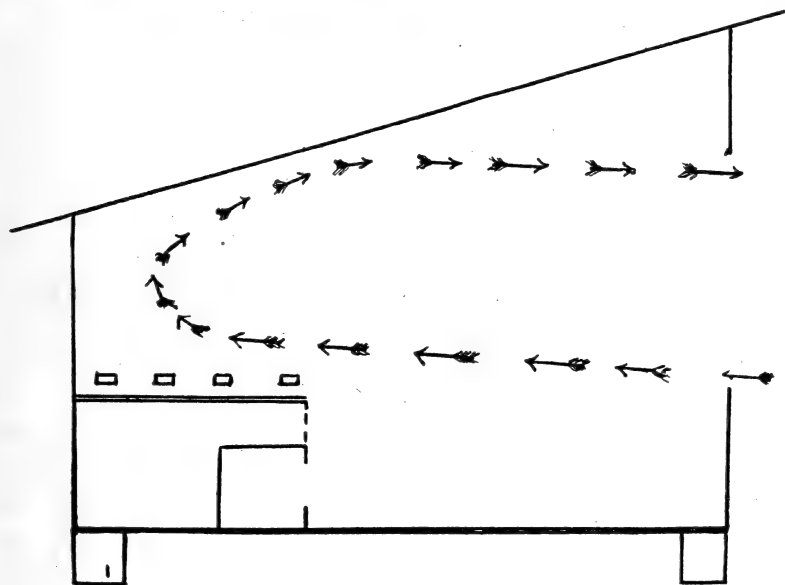

Fig. 17. A diagram of an open-front poultry house for Southern climates with no ventilator in the back. This illustrates ventilation by diffusion. The air passes in at the lowest point of the open front, gradually diffuses back over the birds, then passes upward as it becomes warmed and finally exudes through the upper part of the open front.

89. How to Make Houses Cool in the Summer Time. Straw lofts absorb the heat from the roof and make the houses cooler. The straw loft is made by tacking a two-inch mesh chicken netting to the under side of the rafters and packing the four-inch space thus made with straw. This will make the house ventilated by diffusion much cooler. It is best to provide a ventilator

in the back of the house and keep it open in the summer time and closed in the winter.

90. **Ventilation by Draft.** Fig. 18 shows a cross section of a house built for a cold climate. It is provided with a ventilator at the back and an open front. The air passes in one opening and through the house and out of the opposite opening. The front opening is provided with a drop curtain, which consists of a wood frame covered with muslin. In the summer time this curtain is kept up, as shown in the picture, and in the winter time it is closed down. The fronts of such houses are

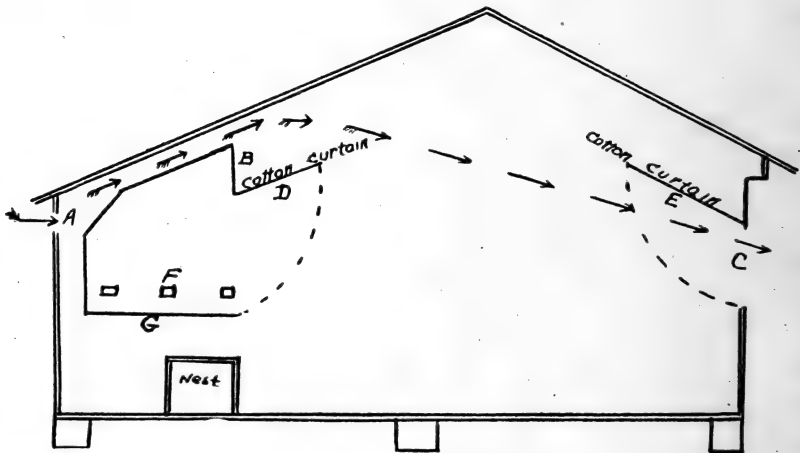

Fig. 18. Diagram showing currents of air through a poultry house. The air enters at *a*, passes under the droppings boards at *b* and *g*, but no draft strikes the birds on the roost at *f*. The air passes through the house, as indicated by the arrows, and out at *c*. For cold climates it is desirable to have a front drop curtain immediately in front of the birds and at the front of the house, as indicated in the drawing. The curtain material must allow of the passage of air through it. (From *Poultry Culture, Sanitation and Hygiene.*)

also furnished with one or more windows to provide light when the drop curtain is down. It will also be noted that the house is sealed as far up as the front of the droppings boards. A curtain is provided at the front of the droppings boards which, as

in the case of the curtain at the front opening, is raised during summer and let down during winter nights to keep the hens warm. Ceiled roofs or straw lofts are necessary in the poultry houses of cold climates, to prevent "sweating" of the walls of the house.

CHAPTER VII

TO REMODEL A POULTRY HOUSE OR TO MAKE A NEW HOUSE

Note to Teacher: Have class remodel or construct a house.

91. To Remodel a Poultry House. It is often necessary to remodel another building to make a poultry house. Repair the roof so that it will not leak when it rains. The sides and back should be stripped with slats, that there may be no cracks through which a draft will pass to the birds. A ventilator should be cut in the back as high above the perch pole as possible. This will prevent a draft directly upon the birds. The front must face the south. Make an opening as illustrated in Fig. 19. The opening should extend the whole length of the house and be three feet wide. The lower edge of this opening should be thirty inches above the ground. Cover this opening with one-inch mesh chicken netting. If the building has a board floor and is raised above the ground so that there is no harbor for rats underneath, it may be well simply to repair the floor and make it tight. If the building has a dirt floor, fill it in with clay, gravel, or cinders until the inside level of the floor is above the surrounding ground, so that the floor will remain dry during rainy and snowy seasons. The ground should slope from the house, in order that the water may drain away from the building.

92. Construction of a New Poultry House. The plan of construction of the small colony house here presented provides for two perch poles eight feet long, which will accommodate twenty-five birds. Twice this number can be provided for where the birds run outdoors all the year round. If the climate is cold, a window should be provided and twenty-five birds should be

the limit for the winter months. The floor may be of concrete, cinders or gravel, dirt, or boards. If it is concrete, there should be eight inches of crushed rock or cinders well tamped in with two inches of cement surface. The top inch should be made of one part cement to two parts sifted sand and the balance of six parts of coarse rock and sand to one part of cement. Bolts should be imbedded in the cement foundation so that the sills may be bolted down. The top of the foundation should slope about one inch to the front. If the floor is of cinders or gravel, it should be four to six inches deep and thoroughly tamped. With the gravel or cinder floor, the sills furnish a harbor for rats that cannot be prevented. If the floor is of dirt, it should be filled in four to six inches above the surrounding ground so as to ensure dryness during wet seasons. If the floor is constructed of boards, flooring should be used. The floor should be twelve to eighteen inches above the ground. In winter the space under the house should be boxed in.

The sides, back, and front walls may be constructed of plain sheathing boards, nailed on perpendicularly, and these boards should be covered with heavy tar paper, or a good grade of boxing boards, planed on one side and battened, may be used. Weather boarding is sometimes used. The most satisfactory walls are made from pieces of four-inch flooring driven tightly together. The roof should be covered with sheathing laid closely together. The surface of the sheathing may be covered with metal shingles, wood shingles, or prepared roofing. The house should be painted.

Where it is desired to keep the cost down, the framing material may be secured from the forest and hewn out, and the studdings may be set in the ground. The sills, being nailed to the studding set in the ground, will be above the surface of the floor and thus harbors for rats will be avoided.

The front of the house is eight feet high and the back six feet. The front opening is three feet wide, which allows an

abundance of sunshine to enter the house. Plenty of sunshine in the house ensures a dry house and healthful conditions for the birds.

The water rack is eighteen inches high, an elevation that prevents the birds from scratching litter into the water, and thereby contaminating it.

The front opening is thirty inches from the floor. The droppings board is arranged horizontally and is thirty inches above the floor.

The perch pole is eight inches above the droppings board. It is made of lumber, two inches by four, with corners planed off and laid flatwise. The perch pole should fit loosely into notches in its supports so as to be removable in case of mites.

The nests should be at least eighteen inches from the floor.

93. Capacity of Perch Poles. Two feet of perch pole space should be allowed for each three hens.

94. Size of Nests. For small breeds, such as Leghorns, the nests should be fourteen inches square. For medium-sized birds, such as Rhode Island Reds, the nests should be fifteen inches square. For the large breeds, such as the Brahmas, the nests should be sixteen inches square.

95. Floor Space. Where birds are kept indoors two or three months or more, as they are in cold climates, four square feet of space per bird should be provided. Where birds run out the entire year, as in warm climates, less floor space is required.

96. Poultry House Equipment (see Chapter VIII). The following is a list of materials for the house:

Front corner posts, 1 piece, 4x4 inches, 16 feet long.

Sills, 4 pieces, 4x4 inches, 12 feet long.

Back corner posts, 1 piece, 4x4 inches, 12 feet long.

Rafters, 6 pieces, 2x4 inches, 14 feet long.

Plates, 2 pieces, 2x4 inches, 12 feet long.

Cross pieces for front opening, 2 pieces, 2x4 inches, 12 feet long.

For broody coop, 1 piece, 2x4 inches, 12 feet long.

Perch poles, dressed all sides, 2 pieces, 2x4 inches, 10 feet long.

Supports for droppings board, 2 pieces, 2x4 inches, 10 feet long.

Perch support, 1 piece, 2x4 inches, 8 feet long.

Lattice for broody coop, and water platform, 2 pieces, 1x2 inches, 8 feet long.

Flooring for front, 4 pieces, 4 inches wide and 16 feet long.

Flooring for front, 9 pieces, 4 inches wide and 10 feet long.

Flooring for ends, 41 pieces, 4 inches wide and 14 feet long.

Flooring for back, 22 pieces, 4 inches wide and 12 feet long.

Flooring for droppings boards, 8 pieces, 4 inches wide, 12 feet long.

Battens for droppings boards and door, 4 pieces, 1x4 inches, 12 feet long.

For roof, No. 3 sheathing, 196 feet.

Hardware:

Hinges for door, roosts, 3 pairs.

Chain to raise roost poles, 2 feet.

Good prepared roofing, 196 square feet.

Wire netting for front and sides of broody coop, 3 yards, one-inch mesh, 24 inches wide.

Wire for front of house, 3½ yards, one-inch mesh, 36 inches wide.

97. Construction Notes. The front and the rear corner posts are four by four inches. The rafters are two by four inches and are placed two feet apart. There is a projection of the roof, one foot back, front, and sides. The front elevation of Fig. 19 shows the open front. The front opening is covered with one-inch chicken netting. For cold climates part of this opening is provided with a window and the open part with a drop curtain (90). The house should face the south. The front elevation shows a hole, twelve inches square, to allow the hens to pass out and in. This is guarded by a door which can be shut at night to keep the rats out, thus preventing them from consuming mash. It also keeps out minks, skunks, opossums, and other enemies of poultry. The nests are placed just below the droppings board, or along the side wall. The first perch pole should be fourteen inches from the back wall of the house and the perch poles should be twelve inches apart and fourteen inches from the front edge of the droppings board. The droppings board is made in eighteen-inch sections, so that it may be removed for cleaning and disinfecting. The water rack is eighteen inches square. It is constructed of two-inch strips laid two inches apart and supported by two by four-inch braces.

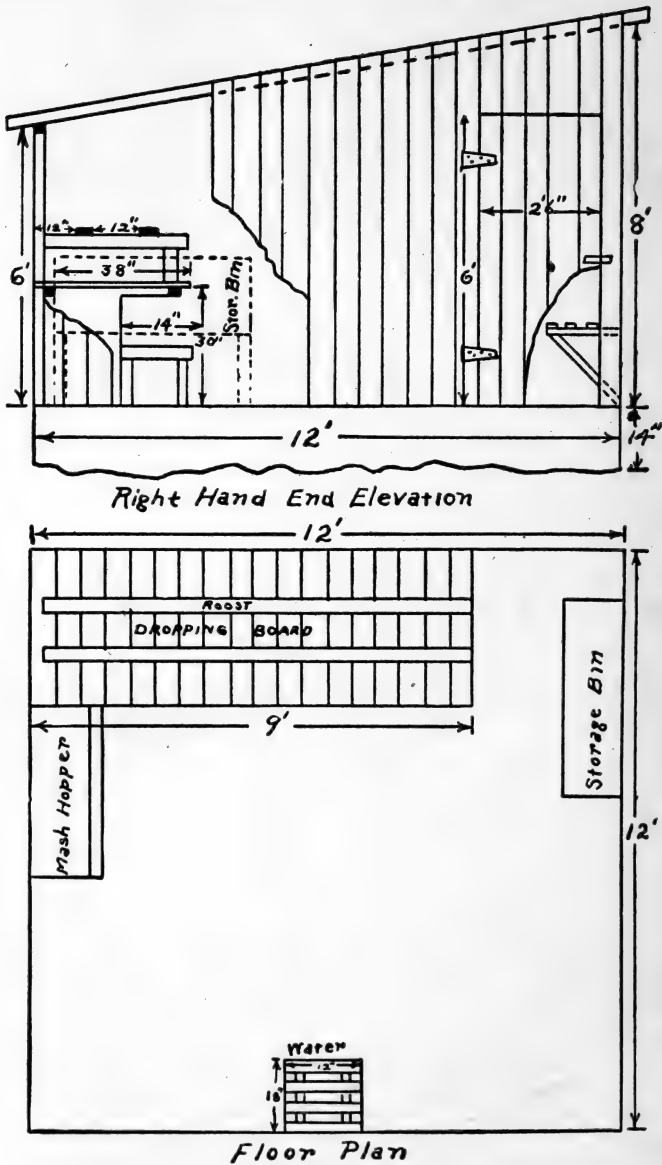
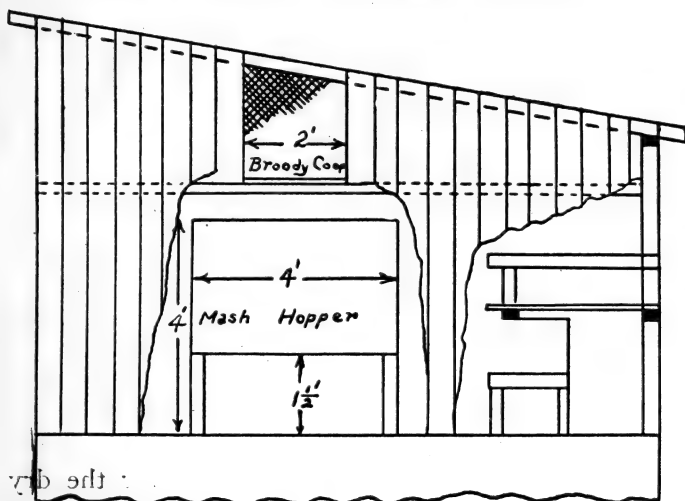
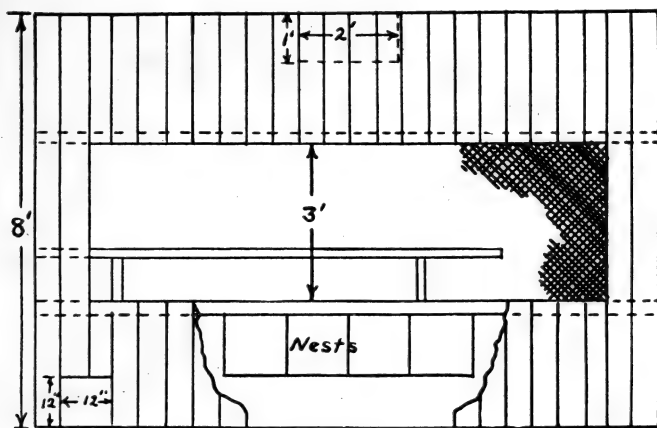

Fig. 19. A suitable poultry house for 25 to 50 birds. The front elevation indicates the position of the ventilator in the back, the position of the nests, a perch pole, the front opening for the hens, and the open front. The front is 12 feet wide and 8 feet high. The left-hand eleva-



Left Hand End Elevation



Front Elevation

tion shows the position of the mash hopper, broody coop, and end view of the nests, dropping board, and perch poles. The right-hand elevation shows the location of the water rack, door, storage bin for feed, nests, dropping board, and perch poles. The front of the building is 8 feet high and the back 6 feet. It also shows the four-inch footing extending into the ground. The floor plan shows the location of the mash hopper and grain storage bin, out of danger of getting wet, and the location of the dropping board and water rack.

CHAPTER VIII

THE CONSTRUCTION OF POULTRY HOUSE EQUIPMENT

Note to Teacher: Have class construct poultry house equipment.

98. **The Poultry House Equipment.** The poultry house equipment consists of a grain storage bin, holding one hundred pounds, for the grain feed commonly called scratch feed; a mash hopper, holding one hundred pounds, for the dry mash which is to be kept before fowls at all times; the nests, furnishing one nest for each four hens; a droppings board box and scrape; a water pan for water and milk; a record board and record sheets for keeping the flock record; litter for the floor in the form of shredded corn stover, straw, or leaves; litter, such as straw or excelsior, for the nests.

99. **Construction of the Grain Storage Bin.** The following list of material is needed to construct one grain storage bin:

- 2 boards, 1 inch by 12 inches, 14 feet long.
- 1 board, 1 inch by 6 inches, 12 feet long.
- 1 pair strap hinges, 8 inches long.
- ½ pound 8d. nails.

100. **Construction Notes.** The back of the bin is thirty-two inches high and the front eighteen inches high. The bin is twelve inches wide and four feet long, with a partition in the center dividing it into two chambers. The steep angle of the top prevents the birds from roosting on it.

101. **Construction of the Indoor Mash Hopper.** The following list of materials is needed to construct one indoor mash hopper:

- 2 boards, 1 inch by 12 inches, 14 feet long.
- 2 boards, 1 inch by 8 inches, 16 feet long.
- 1 board, 1 inch by 4 inches, 16 feet long.
- 1 board, 1 inch by 6 inches, 4 feet long (for ends).
- 1 pair strap hinges, 8 inches long (for top lid).
- 1 pair butt hinges, 2 inches wide (for lid at feed opening).
- 6 $\frac{1}{4}$ -inch rods, 6 inches long (for divisions of feed opening).

102. Notes on Construction of the Indoor Mash Hopper. The ends are made of one twelve and one six-inch board. The six-inch board is placed at the back so that the joint does not come too near the front. The back of the hopper is thirty-two inches

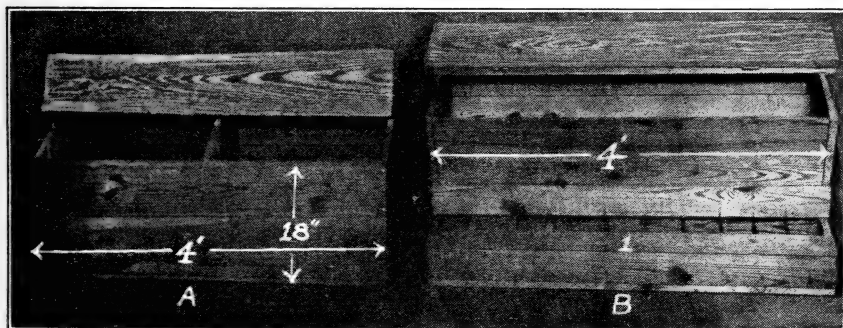

Fig. 20. A.—A grain storage bin four feet long. The front eighteen inches high. The end twelve inches wide, cut to an angle for the top. The top lid open, showing the middle partition and the two compartments. B.—The dry mash hopper with lids open. (1) The strip preventing wasting of mash, just above which can be seen the iron rods.

high. It is made of two twelve and one eight-inch boards. The bottom is twenty inches wide and is likewise constructed of one twelve-inch and one eight-inch board. The eight-inch board is placed at the back so that the angle board covers the joint at the bottom. An eight-inch board is placed in the angle at the back and bottom so that the mash will readily feed down. The front board, which is placed at an angle, extends to within four inches of the bottom or floor. This prevents the too rapid feeding of the mash. A two-inch strip is placed on the front of the

hopper opening and extends over the opening about one inch, to prevent the birds throwing the mash out with their beaks. The feed opening is four inches wide and extends the entire length of the hopper. A lid is provided for this opening and is hinged at the back edge and provided at the end with a hook and eye, so that it may be left up for the birds to secure the mash, or it may be put down to keep rats out, in case the hens require mash only part of the time. One-fourth-inch iron bars are placed across the feed opening so that the birds cannot get their feet into the mash. At the end there are three compart-

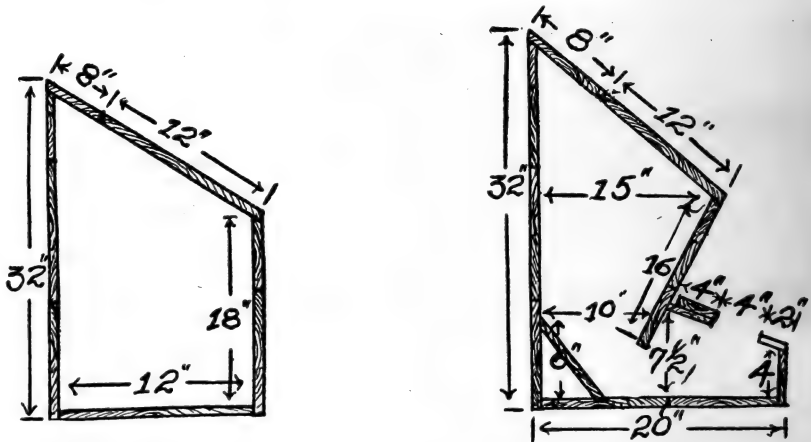

Fig. 21. A, the end of a grain storage bin. B, the end of a dry mash hopper.

ments formed by three partitions, which extend to the top. These are for grit, shell, and charcoal. The larger compartment will hold one hundred pounds of dry mash. The top is constructed at a steep slant so that the birds cannot roost upon the top of the hopper. The opening into the top of the hopper is twelve inches wide.

103. **Construction of the Nests.** The following list of materials is sufficient for the construction of six nests:

- 1 board, 1 inch by 14 inches, 8 feet long (for partitions).
- 1 board, 1 inch by 8 inches, 7 feet long (for door).
- 8 boards, 1 inch by 4 inches, 7 feet long (for bottom, front, back, and run board or step).
- 2 boards, 1 inch by 2 inches, 7 feet long (to nail netting to).
- 2 pair strap hinges, 8 inches long.
- 1 piece netting, 24 inches wide and 7 feet long.
- $\frac{1}{4}$ pound 8d. wire nails.
- $\frac{1}{4}$ pound chicken netting staples.

104. **Notes on Construction of the Nests.** The nests are constructed with the inside compartments fourteen inches square. The top and bottom are provided with a strip two inches wide

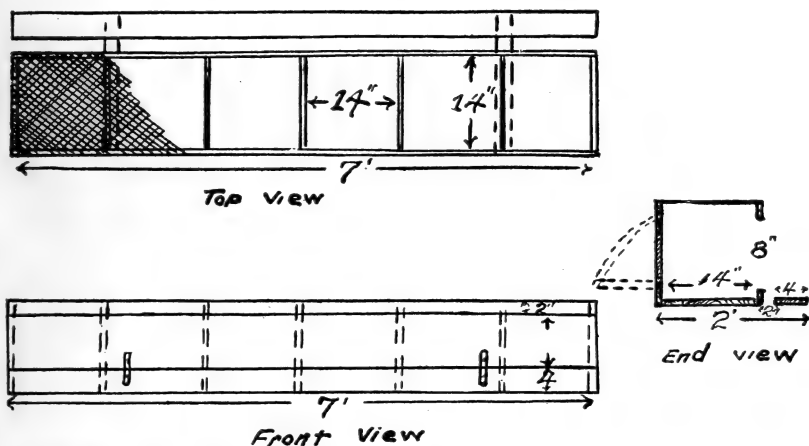

Fig. 22. The nests. The top view shows the wire netting and run board. The front view shows the hinged door. The end view, showing the end of the run, entrance opening, door, top, and bottom.

extending around the outer border, to which one-fourth-inch mesh wire netting is stapled. The front opening is covered with a board eight inches wide and is hinged at the bottom and hooked above, so that by letting it down the nests may be got at. The bottom strip to which this is hinged is four inches wide, and there is a strip along the top border two inches wide, to which the door is hooked. There is a strip, four inches wide in the back and at the lower portion of the nests, which retains the

nesting material. A run board or step, four inches wide and extending along the entire length, furnishes a step for the birds to hop upon when entering the nests. This strip is held in position by a cleat and a space two inches wide is provided between the step and the nests. The partitions are located fourteen inches apart (Fig. 22).

105. **The Construction of the Droppings Box.** The droppings box is sixteen inches wide, twenty-four inches long, and eleven

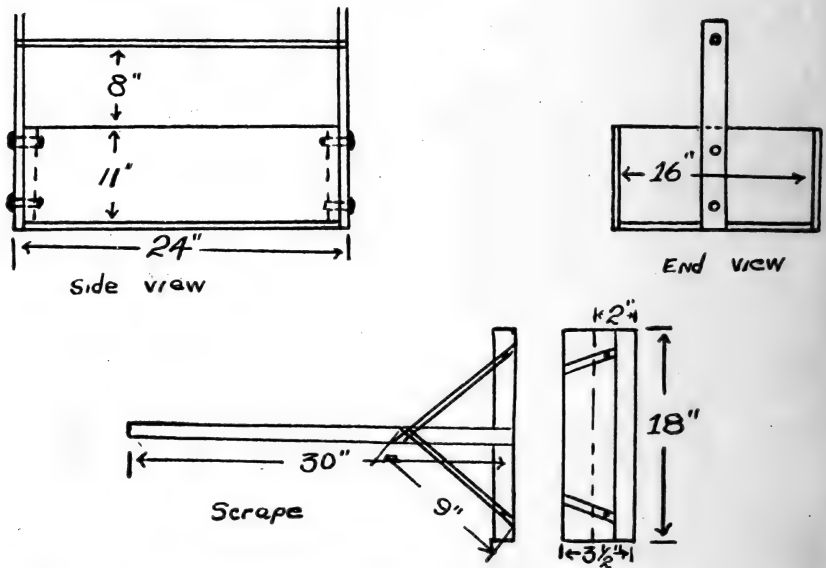

Fig. 23. The droppings box and scrape, showing side and end views of the box, and top and front views of the scrape.

inches deep. It is provided with a handle. The handle is made from two pieces, one inch by two inches, bolted to the sides of the box, and a piece of a broom handle held in position at the top by boring two holes in the top part of the upright pieces. The box should be constructed of some light wood such as white pine or cottonwood and should be of thin material (Fig. 23).

106. **Making the Scrape.** The cross piece or body of the scrape is made of one-inch by four-inch material, cut to a feather edge at the lower part of the blade of the scrape. To the body of the scrape, a handle about thirty inches long is nailed. The scrape part should be eighteen inches long (Fig. 23).

CHAPTER IX

FENCES AND YARDING CHICKENS

Note to Teacher: Visit farm showing fencing material in use.

107. **Kinds of Posts.** The kinds of posts used for fencing are wood, steel, and cement.

108. **Kinds of Wood Posts.** Wood posts are round, split, or sawn. Round wood posts are made from small trees or from the tops of larger trees. Round posts should be peeled. Split posts contain more heart wood than round posts and will last much longer. Sawn posts contain more of the heart wood than either of the other two. They are sawn five inches square. Heart wood lasts longer than the outer portions.

109. **Durable Wood Posts.** Certain woods last longer than others. Among these more durable woods are hedge, white oak, cedar, and elm.

110. **Posts Not Durable.** Among the posts that are not so durable may be mentioned hickory, black oak, and pine.

111. **How to Make Posts Durable.** If the posts are round or split, peel off the bark. This can be done with a draw knife. Soak with creosote the part that goes into the ground and twelve inches above the ground line. Such woods as pine and hickory can be made to last for more than ten years by this treatment.

112. **Steel Posts.** Steel posts are the most durable, but are quite expensive. The end posts and the corner posts are set in a block of cement eighteen inches wide and two feet long. The end posts have a steel brace, which is likewise set in cement, and the corner posts have two braces, both of them set in cement. The wire is stretched tightly from one end post to the other and held by line posts. The line posts are driven about eighteen inches into the ground and are used to hold the fence

in position. Only a heavy wire fence is used with steel posts.

113. Cement Posts. Cement posts are made in molds and consist of one part cement to two parts of finely sifted sand. The posts are made eight feet long, so that they may be set three feet in the ground, leaving five feet above ground.

114. Reinforced Cement Posts. Reinforced cement posts are made by placing wire or old strips of iron in the center of the post as the cement is poured. This strengthens the post. Cement posts not reinforced will break easily. Reinforced cement posts seldom break and will last a lifetime. Cement posts are made eight feet long.

115. Three Kinds of Wire Fencing Material for Chicken Fences. These are the six-sided mesh, a light wire, the three-sided mesh wire, slightly heavier than the six-sided mesh wire, and the heavy poultry wire.

116. The Six-Sided Wire Fencing. The six-sided light wire fencing material is the most commonly used, but is the least durable of the three kinds. There are different sizes of meshes, namely: three-fourths inch, one-inch, and two-inch mesh. It is difficult to stretch this wire and make a neat, lasting fence. It is likely to sag at the top and not fit tightly at the bottom. The bottom can be made to fit tightly on the ground by using stakes made from one-inch by two-inch sticks, twelve inches long, with a nail driven through the top in such a way that, in driving the stake down, the nail will catch the lower strand of wire and hold it close to the ground. A barbed wire can be stretched along the top and the top strand of wire lashed to this barbed wire, either with pieces of baling wire or with hog rings. A board panel made by using a one-inch by four-inch strip, both at the ground and at the top, to which the wire can be nailed, makes a fence of better appearance.

117. The Three-Sided Wire Fencing. Recently there has been placed on the market a wire netting of two-inch mesh and of heavier wire. This netting can be stretched in the same manner

as the six-sided mesh netting. It is somewhat more satisfactory than the six-sided mesh netting.

118. **The Heavy Poultry Wire.** More recently there has been put on the market a heavier fence, made from a wire similar to that used as fencing material for hogs and cattle. The meshes are rectangular. The spaces next to the ground are one and one-fourth inches, that is, the lower wires are one and one-fourth inches apart; the spaces gradually widen as the top is approached. The top wires are only six inches apart. This fencing can be used with wood, cement, or steel posts. It is generally used with steel posts. With steel posts, such fencing is quite expensive, but steel posts are the cheapest in the long run, as they will last much longer than any of the other kinds.

119. **How to Set Posts.** It is best to set posts from thirty inches to three feet in the ground. Fill in the ground gradually, tamping the dirt thoroughly from the bottom of the hole to the surface of the ground. If too much dirt is filled in before it is thoroughly tamped, the bottom of the post will not be held firmly and will soon become loose.

120. **Bracing Posts.** All end posts must be braced from the wire side and all corner posts must be braced in two ways.

121. **Standard Height of Poultry Fences.** The standard height of poultry fences is five feet, or sixty inches.

122. **Fencing Poultry on the Farm.** On the farm, the garden and not the poultry should be fenced. Fowls should be allowed the run of the farm, as they will forage in the summer for much of their feed in the form of waste about the barn and fields. They will consume bugs and insects, which make excellent animal food for them; while by consuming bugs and insects, they protect the crops against these pests. Poultry running over the farm deposits droppings, which aid in fertilizing the ground.

123. **Fencing Poultry on the Town Lot.** If poultry is kept on a town lot, it may be advisable to fence this in to prevent the

fowls from annoying neighbors. When birds are shut up in a pen, it is necessary to compensate them for the loss of insects and green feed which they would secure on the range. The lot should be divided into two parts, one being sown in rape, cow peas, or oats, depending on the season, while the flock should be kept in the other part. By this means, green feed may be provided the year around.

CHAPTER X

CONTAGIOUS DISEASES OF POULTRY APPEARING IN FALL

Note to Teacher: Bring into the classroom a bird with one of these diseases.

124. Roup, sorehead, swollen eyes, and diphtheria most often occur in the fall.

125. **Cause of Roup.** Roup is caused by a germ. A germ or bacterium is a vegetable organism so small that it must be magnified one thousand times by the microscope in order to be visible. Roup affects the nose and nasal passages of the head.

126. **How Roup Is Spread.** The germs of roup may live in the yards and hen houses from one fall or winter to the next. The disease may be spread by a chronic carrier, that is, a bird that has had it and has apparently recovered but that still gives off the germs. Such a bird will sit around on the perch much of the time. It has a pale face, dried down, hard, stiff comb, and is light in weight. It will be observed occasionally to sneeze; and if examined closely, a small amount of dried scab around the nostril will be seen, besides a very thin discharge, scarcely observable and of an offensive odor. Such a bird should be killed and its head and body burned, as it constantly deposits this discharge, containing the germs of the disease, in eating and drinking. As soon as the weather conditions are such as to favor the development of roup, the disease again breaks out. Roup may be spread by introducing a sick bird into the flock, or by shipping a bird in a coop in which a roupy bird has been kept, or by placing birds in runs or houses where birds sick of roup have been kept.

127. **How You Can Tell Roup.** A bird may have a light or

a severe attack of roup. If the attack is light, there will first be noticed a slight discharge at the nose, the bird will be dull, and will not appear to feel well. It does not leave the perch and house as soon in the morning as usual and does not scratch for food as usual. The feathers may appear rather rough. In severe cases great depression will be noticed in the bird. The discharge from the nostrils is great and of a very offensive odor. An accumulation of this matter may clog the cavities of the head, when a lump below the eye will be observed. The bird will appear weak, will not eat, stands around in a tucked-up posture, rapidly becomes poor in flesh, and soon dies.

128. Treatment of a Bird With Roup. A bird with roup should immediately be removed from the flock. If the disease is of a severe type and you think the bird is sure to die, immediately kill it and bury or burn the head and body to prevent the spread of the disease. If you think it will get well, you may treat it. If the trouble proves to be only a common cold, one treatment may effect a cure. Have an assistant hold the bird with the head down. Use a small one or two-dram hard rubber syringe which has the nozzle filed down so that you can insert it into the bird's nose. Inject through the nasal passage a warm solution of common baking soda. Use one-half teaspoonful of common baking soda to half a cup of warm water. This will cut the accumulation and leave the inflamed mucous lining clean, so that a drug can now be applied that will relieve the inflammation. Inject a small quantity of the following mixture through the nasal passage:

Oil thyme	30 drops
Oil eucalyptus	30 drops
Menthol	10 drops
Oil petrol	2 ounces

Repeat this treatment twice a day.

By holding the bird with head down, the material forced through the nasal passage will not get into the windpipe. The

strong hard rubber syringe will drive the material clear through the nasal passage and out into the mouth through the slit in the upper part of the mouth. If the bird's head is held down, this material will run out of the mouth and not infect the wind-pipe (trachea) and thus cause complications. Always wash the hands in a 4 per cent solution of some standardized coal tar disinfectant dip before handling other birds.

129. How to Prevent Spread of Roup. Thoroughly clean the yard and house. Spray the house thoroughly with a 4 per cent solution of some standardized coal tar disinfectant dip. Such a dip can be secured at any drug store and should have a coefficient of at least 5 per cent. Put permanganate of potash in the drinking water. Get a fruit jar and fill it with water. Place in this water crystals of permanganate of potash until some of it is left in the bottom undissolved. When the drinking water is prepared for the flock, pour in enough of this stock solution of permanganate of potash to make the water slightly purple. Always promptly remove all birds with roup from the rest of the flock and look out for the chronic carrier.

130. Swollen Eyes. Usually but a single eye is found to be swollen at a time. The germs of roup are responsible for one kind of swollen eyes. In this kind, the lining of the eye will be noticed to be red or inflamed. There will be an accumulation of a white, clot-like matter. When the bird sleeps at night, a small amount of this material dries along the outer edge of the eyeball, with the result that the bird cannot open its eye in the morning. The material continues to accumulate and the eye becomes enormously swollen.

131. How to Treat Swollen Eyes. Gently press open the eyelids with the thumb and finger. Remove with a small pledget of cotton this white, clot-like mass and inject a small quantity of soda solution, as in the case of roup (128). Then inject a small quantity of the oil, as in roup. Repeat this treatment twice a day. A 10 per cent solution of argyrol or a 1 per cent solution of zinc sulphate may be used.

132. Diphtheria or Avian Diphtheria. This is the mouth type of roup. When roup occurs among birds, each bird should be caught and its mouth opened to see if there are any sores within. These sores may cover quite a surface and are accompanied by a gummy, cheesy material. In such a case the bird shows symptoms much like those described above in nasal roup (128). It cannot eat, and these sores may extend down into the throat. With a dull knife, scrape all the material off and burn the surface with a stick of nitrate of silver till all the parts are white. Repeat this treatment in a few days if the sores do not disappear.

133. How to Tell Sorehead. The first sign of sorehead is a depressed condition of the bird. It does not appear as lively as usual, and small pimples appear on the comb, face, or wattles. These are hard and red and gradually become larger. If the disease is a severe one, the top becomes sore, and these sores spread over much of the unfeathered part of the head. Sometimes the disease is very light, causing only one or two small pimples or sores on the comb or wattles and not depressing the bird very greatly. The disease may be spread by mosquitoes or it may be spread like roup (126).

134. How to Treat Sorehead. Take the same steps as in roup (128). Apply some of the oil preparation as used in roup and sore head (128) and repeat in about three days. Two applications often result in a cure. The pimples and sores may be touched with tincture of iodine or burnt with a stick of nitrate of silver.

CHAPTER XI

THE DIGESTIVE TRACT OF THE FOWL AND ITS FUNCTION

Note to Teacher: Hold postmortem and demonstrate all parts of the digestive tract of a hen. A laying hen preferred. For reference reading see *Anatomy of the Domestic Fowl*, published by W. B. Saunders Co., Philadelphia, Pa.

135. **The Organs Through Which Food Passes.** The food is taken up by the beak and, by a backward movement of the tongue and a jerk of the head, is thrown back into the throat and passes down the first part of the esophagus (No. 2, Fig. 24). The esophagus gives passage to the food to the crop (No. 3, Fig. 24). The crop is simply a storehouse for food. From the crop the food passes through the second portion of the esophagus to the proventriculus, a spindle-shaped organ just in front of the gizzard (No. 4, Fig. 24). The proventriculus secretes a strong acid and pepsin, in which the food soaks before it passes to the gizzard. From the proventriculus the food goes on to the gizzard (No. 5, Fig. 24). The gizzard is provided with strong muscles and has a thick pad lining it. In the gizzard the food is ground and is mixed with a ferment secreted by glands in the gizzard walls. This ferment is pepsin and aids in digesting the food so that it can be used by the body. From the gizzard the food passes into the loop or the first portion of the small intestine (No. 6, Fig. 24). Here it is mixed with a fluid which is manufactured by the pancreas (No. 13, Fig. 24). From the small intestinal loop the food passes into the floating or free portion of the small intestine, where it is mixed with a fluid secreted by the intestinal wall. All of these fluids contain ferments which digest the nutrients of the food and resolve them into a state in which they can be absorbed by the blood and

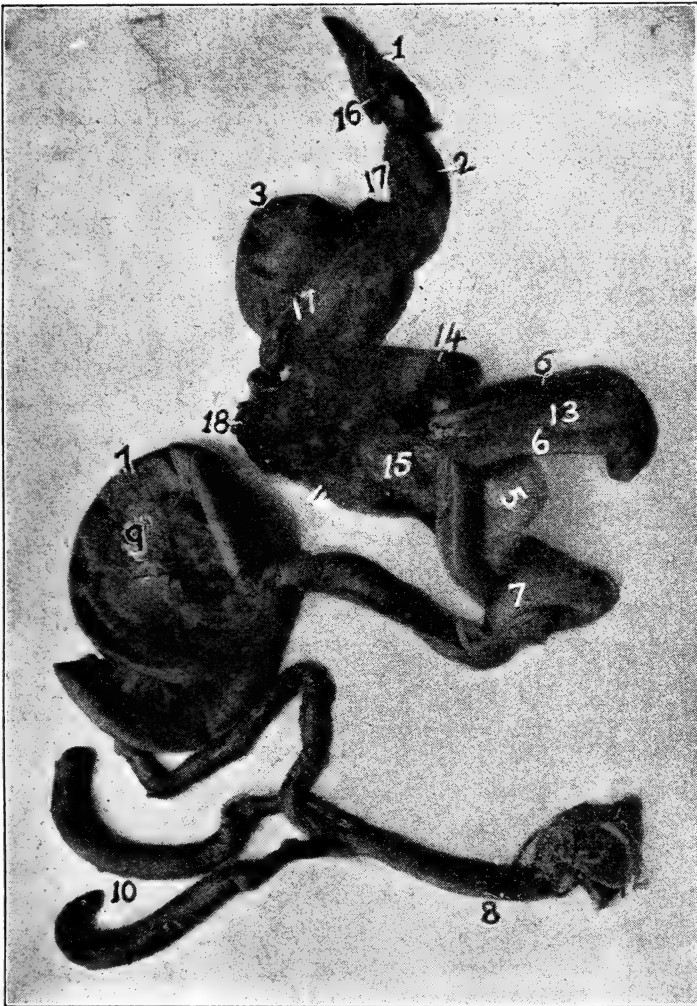

Fig. 24. The digestive and respiratory tracts of the fowl: 1, tongue; 2, first portion of esophagus; 3, crop; 4, proventriculus; 5, gizzard; 6, duodenum or small intestinal loop; 7, free portion of the small intestine; 8, large intestine or rectum; 9, mesentery or web supporting the intestine; 10, caeca or blind pouches; 11, cloaca; 12, anus; 13, pancreas; 14, liver; 15, spleen; 16, larynx; 17, trachea; 18, lung.

used to nourish the body. No. 14, Fig. 24, is the liver, which secretes bile or gall and from which gall is poured out into the small intestine about fourteen inches from the point of origin of the latter. The bile aids in the digestion of the fats of the food; indeed, without it fats cannot be digested. From the small intestine the food passes into the two blind pouches called caeca, which are shown at No. 10, Fig. 24. From this point the food continues into the large intestine, shown in No. 8, Fig. 24. Both the caeca and the large intestine contain glands in their walls and secrete a fluid which contains ferments of aid in digesting the nutrients of the food. From the large intestine the food that is undigested and unabsorbed passes into a sac called the cloaca and is then passed out.

136. The spleen (No. 15, Fig. 24) is a small body shaped much like a horse chestnut and is a blood-forming organ.

137. **The Organs of Breathing or Respiration.** The air passes in at the nostrils, through the nasal passage, out at the back part of the roof of the mouth, into the throat, and then into the windpipe, as shown in No. 16, Fig. 24. The air next passes through the windpipe, into the lungs (No. 18, Fig. 24), then into the air sacs.

CHAPTER XII

POULTRY FEEDS AND THEIR VALUES

138. **What a Nutrient Is.** A nutrient is a substance which can be taken into the body, digested, and absorbed. When a nutrient has been digested and absorbed, it is capable of nourishing the body.

139. **Kinds of Nutrients Required.** There are three kinds of nutrients required. They are protein; starches and sugars, called carbohydrates, and fats, called hydrocarbons.

140. **What Protein Is and Its Function in the Body.** Protein is the only nutrient of poultry feeds containing nitrogen. Protein aids in building up muscles, bones, and intestinal organs. If a surplus is taken in, it goes to form fat in the body.

141. **What Starches and Sugars Are and Their Function.** Starches and sugars contain carbon, hydrogen, and oxygen and are used in the body for the production of heat and energy, much as an automobile uses gasoline for the production of heat and energy. If a surplus is taken into the body, it is converted into fat or is stored up as glycogen until it is needed by the body for combustion.

142. **What Fats Are and Their Function.** Fats, like starches and sugars, contain carbon, hydrogen, and oxygen, but in different amounts. Fats are similar in function to starches and sugars. They are used to produce heat and energy, and a surplus left over is stored up as fat in the body of the bird.

143. These three groups of food nutrients must be in the proper proportion to give the best results.

144. **Corn.** There are three kinds of corn of interest to poultry feeders. These are flint, dent, and sweet corn. Corn does not make a complete feed by itself. It must be given with other grains and is then one of our very best feeds.

145. **Forms in Which Corn Is Fed.** Corn is fed whole to laying hens. Cracked corn is fed to chicks and to young chickens on range. Ground corn or corn meal is used in the ground mixtures for young chickens, in the mash for the birds on range, and for laying hens. Gluten feed is a by-product of the corn used in the manufacture of starch and is rich in protein. It is therefore one of our most useful high protein vegetable feeds for mash mixtures.

146. **Wheat.** Wheat is richer in protein or muscle-building nutrients than corn and is fed as whole wheat to young chicks, growing chickens, and laying hens. Cracked wheat is fed to baby chicks. There are three by-products of wheat, namely: shorts, middlings, and bran. These by-products are used in the mash mixtures for both young and old birds.

147. **Rye and Barley.** Rye and barley are not quite so good for feed as wheat, but may be used as a substitute when found necessary.

148. **Oats.** Oats are one of the standard feeds, both for old birds, as whole oats, and as crushed oats in the mash for young and old birds. Hulled oats and pinhead oats are used in feeding young chickens.

149. **Rice and Buckwheat.** Rice and buckwheat are not used extensively, but can be used partly as substitutes for wheat, corn, and oats.

150. **Cottonseed Meal.** Cottonseed meal is rich in protein, but it contains a poisonous substance called gossypol. If too much is fed, it has a bad effect on birds, causing them to become sick of it, lose their appetite, and even die. Not over 10 per cent of cottonseed meal should be fed in the mash feed. If not more than 10 per cent is fed in the mash, it proves a good feed for young chicks and for laying hens. Cottonseed meal sometimes causes dark brown yolks in the eggs. Most people object to these brown yolks, though they in no way render the eggs unwholesome.

151. **Soybean Meal.** Soybeans, like cottonseed, are used by the oil mills for the production of oil. After the oil is pressed out of the ground soybeans, the residue is ground and sold in the market as stock feed. Soybean meal is very rich in protein and is one of the very best feeds for both chicks and laying hens.

152. **Peanut Meal.** Peanuts are ground by the oil mills and their oil extracted by hydraulic presses. After the oil has been pressed out, the residue is ground and sold in the market as stock feed. Peanut meal is rich in protein and is one of the very best feeds for poultry, both young and old.

153. **Velvet Bean Meal.** Velvet bean meal, consisting of ground pods and beans, is injurious to both young and old birds and is not recommended for poultry feeding.

154. **Meat Scrap, Fish Meal, and Blood Meal.** Meat scrap, fish scrap or meal, and dried blood or blood meal are used as poultry feeds. These are called animal feeds and furnish our birds with animal protein. Animal protein is essential if the maximum growth or the maximum egg production is expected. If the birds run on range, they will get their animal feed in the form of bugs and insects, but in the winter time and when shut up, as in back lots, it is necessary to furnish them with animal food.

155. **Milk.** Milk is a common form of animal food for chickens. It may be fed as sour skim milk, in semi-solid forms, as those bought from some of the creameries, as dried buttermilk, or as buttermilk direct from the churn. Buttermilk is a common feed for chicks and is of aid in preventing diarrhea.

156. **Green Feed.** Green feed is essential for growing birds, as well as for breeding and laying stock. This may be furnished by allowing them to run on a green field, or by supplying them with sprouted oats, mangels, collards, or cabbage grown during the summer.

157. **Spoiled Feeds.** Spoiled feeds such as moldy grain, mill feeds, or moldy table scraps must be avoided, as birds are easily made sick by spoiled food.

158. When and How to Plant Grazing Crops for Poultry. Grazing crops can be provided most of the year for poultry. In part of January and February, and this especially holds true in the mountain section, it is necessary either to sprout oats or provide mangels or turnips. For best results in egg production, birds must be provided with succulent feeds.

The tabulation on the next page will be found useful information for the beginner:

PLANTING OF GRAZING CROPS FOR POULTRY

<i>Crop.</i>	<i>When Sown.</i>	<i>Amount of Seed Per Acre.</i>	<i>Grazing Stage.</i>	<i>Period Duration.</i>
Peas and Oats.....	April 15	1 bushel peas, 2 bushels oats	May 20	Until full grown.
Rape	May 10	3 pounds	8 to 10 inches high	Until consumed.
Red Clover	Aug. 20	12 pounds	May 15	Until fed down.
Turnips	Aug. 20	3 pounds	September 20	Until snow falls.
Buckwheat	May 10	1 bushel	In six weeks	Until mature.
Soybean	May 10	1 bushel	12 inches high	Until mature.
Rye and Crimson Clover.....	Sept. 1	1 bushel rye, 15 lbs. clover	Grazed early winter and spring.	Until mature.
Oats	Sept. 1	1 bushel	Grazed early winter and spring.	
Sweet Clover	Aug. 15	25 pounds	6 to 10 inches high	Until fed down.
Mammoth Prize Long Red Mangels, Orange Globe Mangels	May 1	8 pounds	For winter use.	

Oats may be used for either summer or winter grazing. Rape can be raised spring, summer, and fall if there is sufficient rainfall. Soybeans and cowpeas can be raised spring, summer, and fall as a yard rotation crop, if there is sufficient rainfall. Turnips and mangels make the best root crops for winter feeding. Collards and cabbage, as well as lettuce raised in cold frames, also make excellent succulent feed. In raising mangels it is best to plough the ground deeply in the fall. The freezing will pulverize the ground and tend to make it in better condition for the crop. Good black loam soil is the best. The ground should be manured. If manure is not available, fertilize by distributing four to five hundred pounds of fertilizer to the acre. Plant the mangel seed in rows two and a half to three feet apart, sow thick, later thin out, leaving one strong beet stock to each ten inches. The rows should be ridged, the top of the ridge being about two inches above the surface of the ground. The seed should be planted about one inch deep. Gather the root crops as late in the fall as possible. Bury in the ground until ready to use them. To do this, place about six inches of straw on the ground, then pile or windrow, cover mangels or turnips with about six inches of straw or hay and cover with dirt. In securing the dirt, take that close around the piles of roots so that there will be drainage away from the pile, which will thus keep dry. The roots thus prepared should keep till January and February, when they are most needed. During the fall and early winter grazing crops may be used.

CHAPTER XIII

FEEDING LAYERS AND BREEDERS

Note to Teacher: Have student mix feeds for flock.

159. **Water Supply.** Laying and breeding hens must have a fresh and pure supply of water at all times. Especially in hot weather, water should be kept before the birds without fail. The water containers must be scrubbed or washed out: use the hand to remove the slime which has accumulated on the sides and bottom of the pan. Impure water and polluted water pans are fruitful sources of bowel troubles in hens.

160. **Green Feed Essential.** Green feed can be provided by allowing the hens to run on green fields or plots planted for them; or, if they are in a back town lot, green feed must be carried to them. Each hundred fowls should receive not less than four pounds of green feed per day.

161. **Regularity of Feeding.** Regularity is one of the most important items of feeding. The green feed must be given each day at the same time. The grain feed must be given at the same time morning and evening.

162. **Breeding Birds Must Be on the Ground.** It is necessary for all breeding birds to be out on a grassy run if a high degree of fertility is to be expected.

163. **Grain Feed and Mash.** Grain feed should be given morning and evening. A pint measure of grain should be scattered in deep litter for each twelve hens in the morning and the same quantity in the evening.

164. **Dry Ground Feed or Mash.** Mash consists of a mixture of ground grain and mill by-products. Dry mash should be kept before the birds at all times. Birds on the range will not consume much mash during the summer, when foods such as

waste grain, bugs and insects are so abundant. Later in the fall or in the winter they will consume more, since the mash is used by the birds as a filler. If the hens become too fat, it may be necessary to keep the dry mash hopper closed part of the time.

165. Value of Exercise. Exercise is essential for the best results in laying. In the winter time this exercise can be given by placing a deep litter, such as straw, leaves, or shredded stover, on the floor of the hen house, and throwing the grain feed into this, which causes the hens to scratch for their grain. For this reason grain feeds have been called scratch feed.

166. Minerals for Poultry. Breeding and laying hens need lime and grit. Most feeds are deficient in lime. If the birds run at large, it may be secured from the fields, but if the birds are kept on the back lot, crushed oyster shell should be provided. Birds at large will find sufficient grit in the form of pieces of pebbles and cinders, but if they are kept in a restricted enclosure, crushed limestone should be provided. The limestone will also be a source of lime needed in the body in the manufacture of egg shells and for other purposes.

167. Sufficient Nutrients. If grain alone is fed and the birds do not have a fruitful range or do not receive an ample supply of table scraps, they will not lay many eggs. The white of the egg is pure albumin and the yolk is made up of albumin and fat as well as coloring and mineral matter. The albumin must come from the protein of the feed. Grains do not furnish a sufficient amount of protein for heavy egg production.

168. Reasons for Feeding Mash. Mash contains by-products and animal feeds rich in protein and is essential for high egg production. A mash should contain animal food in the form of meat scrap, fish scrap, dried blood, or dried buttermilk, and at least one by-product high in protein content, such as soybean meal, peanut meal, cottonseed meal, or gluten meal.

169. Hot Mash. Hot mashes given at four o'clock in the

evening during the winter months have a very stimulating effect on egg production. Use milk or water and bring the mixture to a boil. Use enough water or milk to mix with one ounce of mash per bird. Make the mash crumbly moist and as hot as you can bear your hand in. Vegetables, such as shredded mangels, cabbage, or collards, should be boiled in the water or milk.

170. Formulas for Grain Mixtures:

Corn	10 pounds
Oats	10 pounds
Wheat	20 pounds
Oats	10 pounds
Corn	20 pounds
Wheat	10 pounds
Oats	10 pounds
Buckwheat	10 pounds
Corn	60 pounds
Wheat	40 pounds
Oats	20 pounds

171. Formulas for Mash Mixtures:

Beef scrap	3 quarts
Corn meal	8 quarts
Soybean meal	3 quarts
Wheat middlings	4 quarts
Ground oats	3 quarts
Birds given milk to drink.	
Peanut meal	3 quarts
Wheat middlings	4 quarts
Ground oats	3 quarts
Birds given milk to drink.	

If birds are not given milk to drink, add one quart of meat scrap to the last two mash mixtures.

Wheat bran	20 pounds
Wheat shorts	20 pounds
Meat scrap	10 pounds

172. Average Weight and Volume of Feeds:

FEED.	<i>One quart weighs (pounds).</i>	<i>One pound measures (quarts).</i>
Beef scrap	1.3	0.8
Corn meal	1.5	0.7
Corn, whole	1.7	0.6
Cottonseed meal	1.5	0.7
Gluten feed	1.3	0.8
Gluten meal	1.7	0.6
Oats, ground	0.7	1.4
Oats, whole	1.0	1.0
Rye, whole	1.6	0.6
Soybean meal	1.3	0.8
Wheat bran	0.5	2.0
Wheat middlings (flour).....	1.2	0.8
Wheat middlings	0.8	1.3
Wheat, whole	1.9	0.5

CHAPTER XIV

CANDLING AND GRADING MARKET EGGS

Note to Teacher: Have student candle and grade eggs.

173. **Losses From Careless Handling of Eggs.** It has been estimated that the annual loss from the careless handling of eggs amounts, in the United States alone, to \$90,000,000. It is estimated that about 70 per cent of this loss occurs before the eggs arrive in town.

174. **How to Prevent Losses on the Farm.** Remove the male birds from the flock immediately after the breeding season and market no fertile eggs. Provide roomy nests and plenty of clean nesting material, preferably dry shavings or straw. Do not allow broody hens on the nests. Keep the nests clean and sanitary. Collect the eggs regularly, at least once a day in moderate weather and more frequently in very warm weather. Carry them at once in a clean basket to a cool, dry cellar and cover them with a clean cloth to prevent dust from settling on them and also to prevent evaporation and fading. Do not pack eggs loose in a box when taking them to market, but rather secure a suitable egg case and thus avoid breakage. Market as frequently and as directly as possible.

175. **Males Not Necessary for Egg Production.** The male birds are not essential for egg production. They have to do with the fertilization of the egg but not with its formation. Hens should not be mated except when eggs are desired for hatching.

176. **Blood Rings.** When the germ in the egg begins to develop and then dies, after three to five days, there will be noted a red ring in the center of the egg. This is the blood ring.

177. Production of Small Eggs. Pullets lay small eggs. Monogrel hens often produce a large percentage of small eggs. Eggs should weigh one and a half pounds to the dozen or forty-five pounds net to the thirty-dozen case. Small eggs should not be marketed unless there are more than are needed for home use; then they should be sold separately.

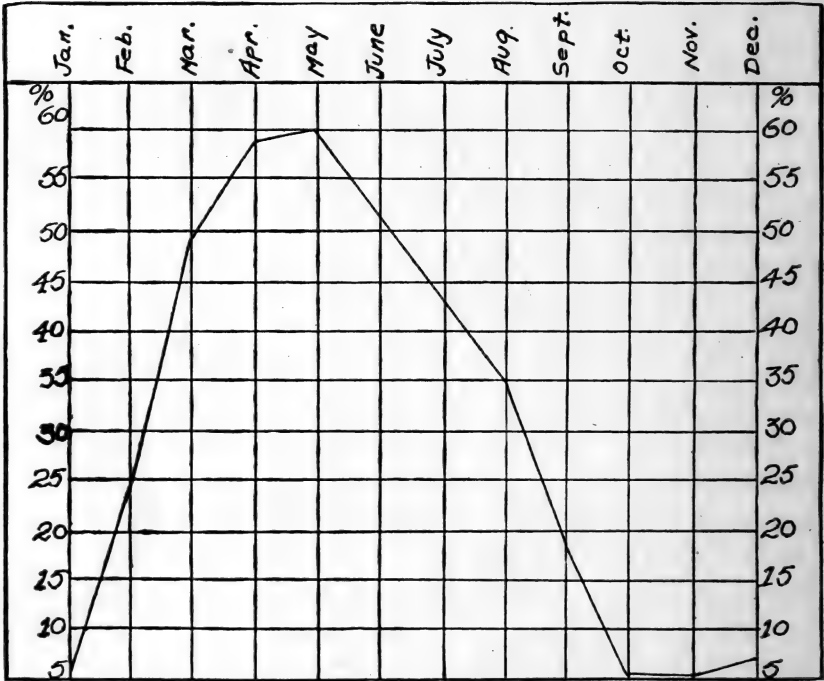

Fig. 25. A graph showing the average percentage of eggs to expect of a flock each month. Note the heaviest production is in April and May. Compare with graph 26 and note that the greatest production is in the time of year when eggs are lowest in price.

178. Grading According to Color. If large and small eggs and white and brown eggs are in the lot to be graded, the eggs should be divided into four lots, as follows: large browns and small browns, large whites and small whites.

179. **How to Ship Market Eggs.** Market eggs should be shipped in thirty-dozen cases.

180. **Construction of the Thirty-Dozen Case.** A thirty-dozen case is made up of two compartments, each of which holds five three-dozen fillers. The fillers are the strawboard cells in which

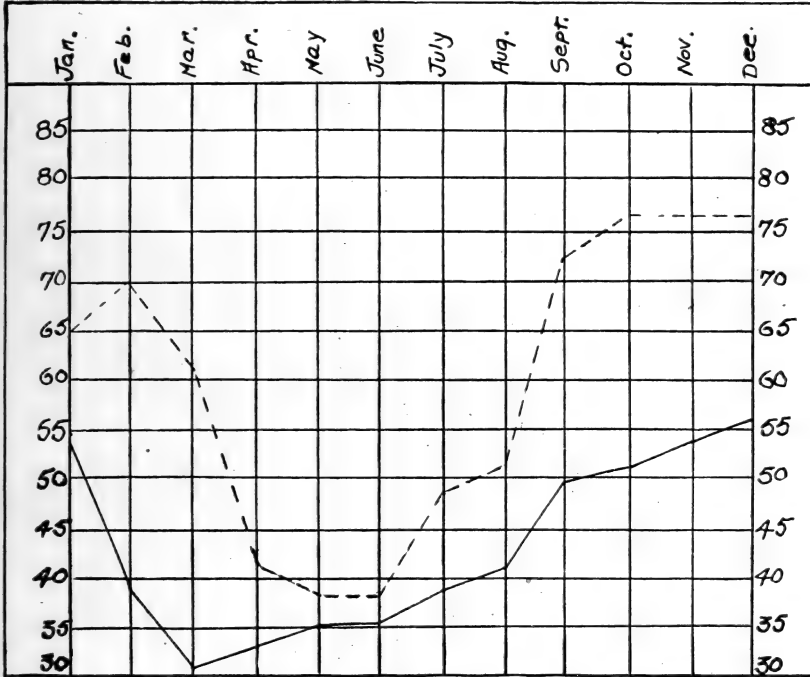

Fig. 26. A graph showing the fluctuation of the prices of eggs each month in the year. The figures along the sides are the prices of eggs each month. Blank line indicates the average prices paid in North Carolina and the broken line shows the prices paid on the New York market. Compare with graph 25 and note that the high prices are in the time of year when the fewest hens are laying.

the eggs are placed. Each filler holds three dozen eggs. Between the fillers are the flats. A flat is a square piece of heavy strawboard just the size of the compartment. There is left a half-inch space above and the same space on the bottom of the

case for a thin layer of excelsior. This excelsior acts as a buffer and aids in preventing breakage.

181. **Hauling Eggs to Market.** Do not haul the filled egg cases in a lumber wagon. A spring wagon or auto truck is required, as the jar of a wagon without springs will result in the breakage of two or three dozen eggs in each case.

% HENS LAYING NECESSARY TO PAY FOR FEED.

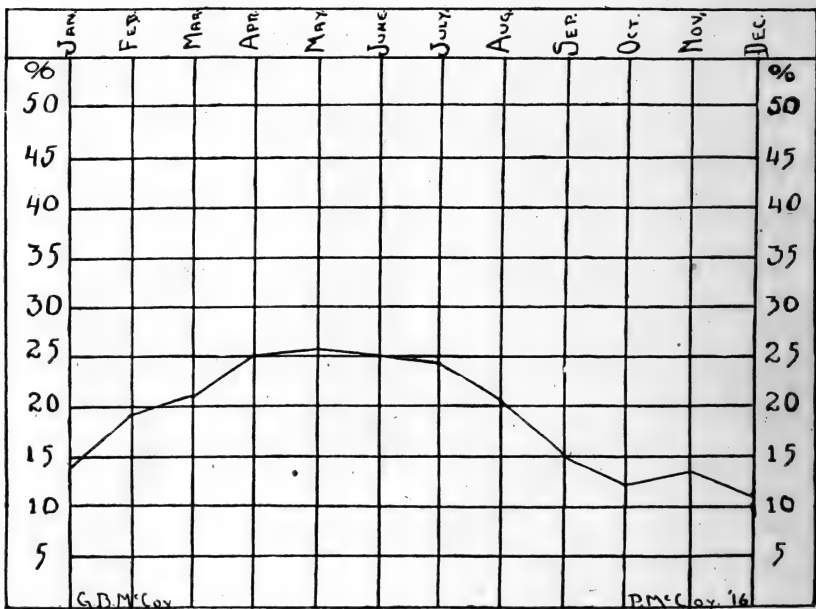

POULTRY DEPT., N.C. A&M COLLEGE

Fig. 27. A graph showing the percentage of hens of any one flock that must lay each month to pay for the feed of the entire flock. Compare graphs 25 and 26, giving monthly prices, and note that the greatest number must lay in the months when the prices of eggs are lowest.

182. **Shipping Eggs for Hatching.** Eggs for hatching should be packed in special parcel post containers. These containers can be purchased in the market. A container should hold just

fifteen eggs. Each egg should be wrapped in soft paper, fine hay, or excelsior before being placed in its cell to insure a "springy" nest for it. Sawdust, bran, or cottonseed pack too closely and are not suitable.

183. **Points in Grading Eggs.** Eggs are graded according to freshness, cleanliness, size, color, and soundness of shell.

184. **Cracked Shells.** Broken shells are called blind checks,

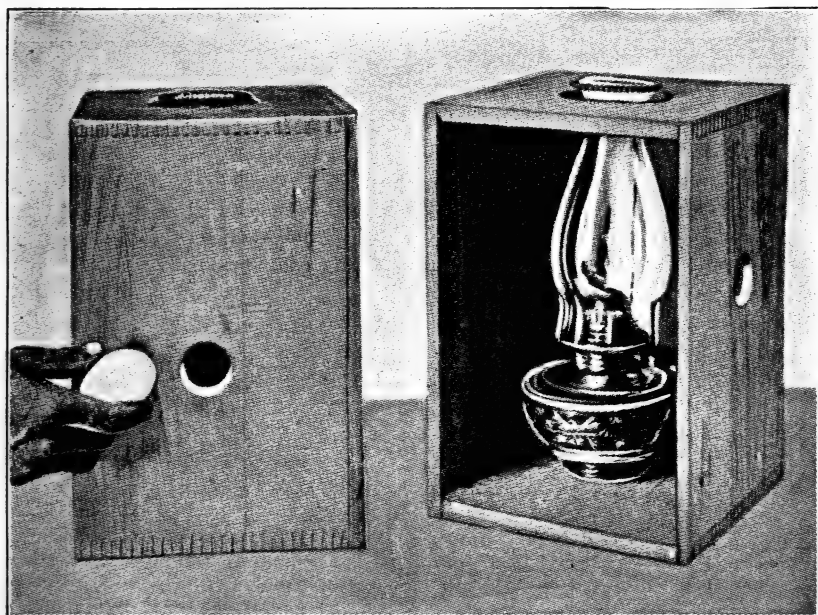

Fig. 28. A HOME-MADE CANDLER.

checks, dents, and leakers. Blind checks can be determined only by the candle test. A crack that is visible is called a check. If the shell is dented and does not leak, it is called a dent. If the crack or dent has a broken shell membrane, the egg contents will leak, and such an egg is called a leaker.

185. **Use of the Candler.** Fig. 28 shows a home-made candler.

The egg is held before the candler with the large end up and inclined at an angle of about forty-five degrees. Slightly jerk the egg sidewise and the yolk will be noted as a dark central mass. If the egg is fresh, the air cell, about the size of a dime, will be seen at the large end of the egg.

186. Change in the Size of the Air Cell. As soon as an egg is laid, the air cell begins to enlarge, a process due to evaporation through the shell. If an egg is kept for some time, the air cell will be enlarged in proportion to the amount of evaporation that has taken place.

187. What to Look For. Your object in candling is to see that all the eggs you place on the market are good for food, for if you guarantee your eggs and have a uniform product, with all eggs up to standard size (177), you will receive more for your product than those selling a poorer product. Always seek a market that will pay a premium for a good product. Look for and reject those eggs that show a blood ring, a blind check, a very dark superficial yolk, which indicates a heated egg, a large air cell, any black objects in any part of the egg, or chick development.

188. An Egg Chart:

FRESH EGGS*

BEFORE THE CANDLE

Air space: Not enlarged; less than three-fourths inch in diameter.

White: Firm and clear.

Yolk: Dimly seen through the white as a shadowy object indistinct in outline. The chick spot is not visible.

Distinguishing characteristics:

No shrinkage and general firm conditions of white and yolk.

Edible.

OUT OF THE SHELL.

White: Firm and thick; opalescent; reflects the light.

Yolk: Spherical and firm; chick spot small with no sign of hatching. Color is uniform for the entire yolk, but varies from light yellow to deep orange; and is occasionally olive green.

Distinguishing characteristics:

General firm condition of white and yolk. White, opalescent.

* The color of a white egg before the candle is yellow with a pinkish tinge, that of a brown egg is pinker, and that of a dark brown egg is almost red. In each instance the color deepens in the region of the yolk.—U. S. Dept. Agr.

HATCH-SPOT EGG

BEFORE THE CANDLE

Air space: Usually enlarged.

White: Thin and clear.

Yolk: A distinct reddish glow around the germinal spot, which is visible; usually located above the middle of the egg.

Distinguishing characteristics:

Reddish glow on the yolk.

Edible.

Occurrence: Chiefly during warm weather or hatching season.

OUT OF THE SHELL

White: Thin and clear; no opalescence; does not reflect the light as strongly as does a fresh egg.

Yolk: Bears a hatch spot; is flattened, being especially weak around the embryo.

Distinguishing characteristics:

Hatch spot on the yolk.

STALE EGG

BEFORE THE CANDLE

Air space: Enlarged; the lower wall may be movable in outline.

White: Thin and clear.

Yolk: Definite in outline; sometimes weak, and may occasionally have dark, mottled areas.

Distinguishing characteristics:

Enlarged air cell and increased contrast between white and yolk as compared with a fresh egg.

Edible.

Occurrence: Among eggs not marketed promptly.

OUT OF THE SHELL

White: Thin; no opalescence; does not reflect the light as much as does a fresh egg.

Yolk: Flattened, and occasionally may have light, mottled areas.

Distinguishing characteristics:

Thin, white, and flattened yolk.

189. Marketing Eggs in Clubs. It is good practice to form a school club under the direction of the principal. The eggs are brought to the school, and each pupil candles his own eggs and places them in the proper grade, taking home any that are not first class. Many such clubs have found it possible to secure from ten to eighteen cents per dozen more than producers around them who did not candle and grade their eggs and sell under a guarantee. Pure-bred hens make a uniform product.

CHAPTER XV

CONSTRUCTION OF THE COMBINATION SITTING AND BROODING COOP

Note to Teacher: Have students make a combination sitting and brooding coop and paint it, ready for use.

190. Natural Incubation. By natural incubation is meant hatching chicks with the hen.

191. Natural Brooding. By natural brooding is meant brooding or rearing chicks with the hen.

192. What the Combination Sitting and Brooding Coop Is. The combination sitting and brooding coop is a small coop with an extension run. The hen is set and, after hatching, is housed in the coop and allowed to run out into the extension run. The hen is confined to the run and the chicks are allowed to roam at large for grass, bugs, and insects.

193. List of Material for One Combination Sitting and Brooding Coop:

- 1 bunch of plaster lath.
- 2 boards, 1 inch by 8 inches by 12 feet (for bottom, sides, and back).
- 6 pieces, 2 inches by 2 inches by 12 feet (for framing for run and house).
- 1 piece of rubberoid, 3½ feet square.
- 3 hinges 4 inches long (two for side door and one for front lattice strip).
- 3 four-inch hooks and eyes (for top and side door).

194. Dimensions of House. The floor is two feet square. The back is eighteen inches high. The front is two feet high. The floor is provided with boards where rats are troublesome. The roof is made to overreach four inches on all sides. The roof is covered with rubberoid. The front is slatted, allowing spaces for chicks to pass out. One slat is hinged in the center, as is shown in Fig. 30, No. 6. If this slat is placed in position, with

the hinge on the inside, the hen cannot push it out. The house is provided with a hinged door on one side. The side door is kept fastened with a hook and eye. The top is held down with a hook and eye on each side, so that the wind cannot blow it off.

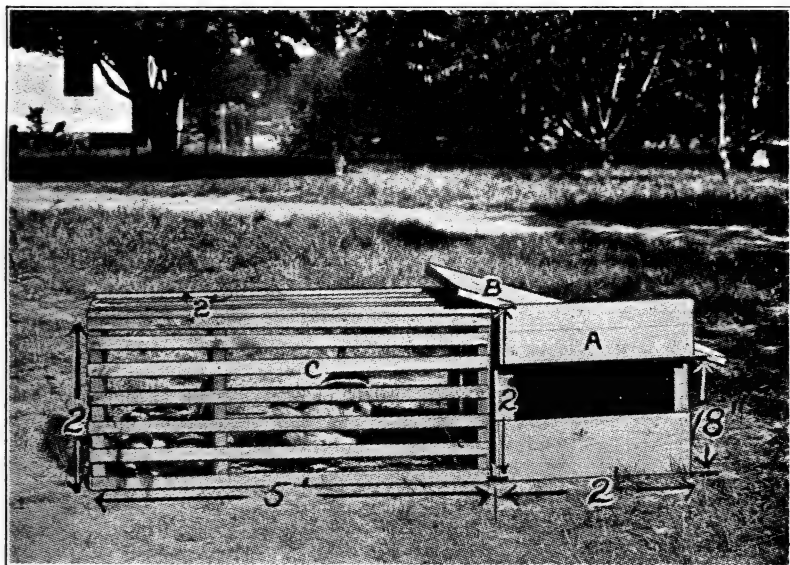

Fig. 29. The combination sitting and brooding coop. A, the open door; B, the top; C, the extension run. The figures give the dimensions of the various parts.

195. Notes on Construction. The roof is of a shed-like structure and so made that two-inch by two-inch framing material fits over the top of the building like a hood. The bottom may be made removable and of eight-inch board. This renders it possible to use the coop in cold weather; and in summer time, if rats do not interfere, it can be removed and the chicks allowed to roost on the ground. The framing material of the coop is two-inch by two-inch. Notches are cut out of the floor to fit tightly around the framing. To keep rats out of the coop, make

a frame of one-inch by four-inch material and tack on the front of this one-half-inch sand screen or netting. This is placed in front of the coop at night. Three eight-inch boards, one cut to an angle, make the side. Hinge the middle board to the bottom one and use a hook and eye to fasten it to the top board.

196. **The Extension Run.** The extension run is the length of a plaster lath. The framing material is of two-inch by two-inch.

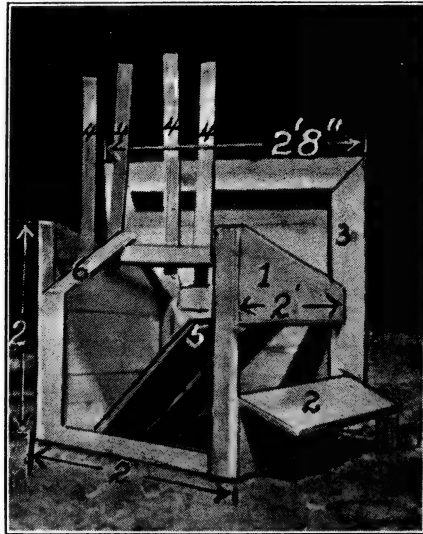

Fig. 30. The sitting and brooding coop. 1, the left, showing angle to cut board; 2, the side door open; 3, the top; 4, the front slats; 5, the removable bottom; 6, the hinged removable slat. Dimensions of the various parts are given.

planking. The framing pieces are cut eighteen inches long and nailed together with 20d. spikes. There are three frames, consisting of four pieces each, one arranged at each end and one in the middle of the run. The slats are placed four inches apart, with a five-inch space at the bottom for the chicks to pass out and in. One of the top slats is removable. This allows feeding and watering from the top of the run.

CHAPTER XVI

SELECTING EGGS FOR HATCHING AND SETTING A HEN

Note to Teacher: Have the students select eggs for hatching and make nest.

197. Kind of Eggs to Select. Select only well-formed eggs. Do not select eggs with ridges around the middle, or eggs that are undersized. Avoid those that have thin shells, those with small ends enlarged, those that are short and round or abnormally long. Ill-shaped eggs should be discarded, as the progeny would not be desirable and they would not hatch well. The average hen egg is 2.27 inches long and 1.72 inches in diameter. No egg less than two ounces in weight should be set, as the markets of the future will grade according to weight per dozen.

198. Age of Eggs for Setting. Do not set eggs over two weeks old. Preferably, eggs should not be over one week old. The sooner an egg is set after laying, the better the hatch.

199. Care of Eggs for Hatching. See that the breeding hens have clean nests. Place the eggs in a clean basket or other container and leave it in a dry, cool place. Cover with a cloth or paper. Remember that hatching changes occur in eggs kept at temperatures above 70° F. and that an egg freezes at 28° F. Do not allow broody hens to remain on the nests of the laying hens. Hauling over rough roads or rough handling may cause internal injuries that would interfere with the hatching qualities.

200. Hatching Expectancy. Out of fifteen eggs set under the hen, on an average one may expect ten chicks, and if they are shipped a distance by parcel post or express, eight is the average per sitting. Set fifteen eggs under each hen.

201. **Vigor of Chicks.** If the hen is irregular in sitting and stays off the nest too long, thus allowing the eggs to become chilled, or if the eggs are in an incubator and the temperature is irregular or too high, the chicks will be more or less weak. A large egg hatches a large chick, and this chick outgrows the small, runty chick hatched from a small egg. Immature cockerels produce weak chicks. Improper care and feeding of the breeding stock also tend to the producing of weak chicks.

202. **When to Hatch Chicks.** The utility breeds, such as the Plymouth Rocks, Rhode Island Reds, and Wyandottes, should be hatched in February and March. The smaller egg producing breeds, as the Leghorns, should be hatched from the last week in March to the first week in May.

203. **Average Length of Time Required to Hatch Eggs.** Hen eggs hatch in twenty-one days, goose eggs in thirty days, duck eggs in twenty-eight days, turkey eggs in twenty-eight days, guinea eggs in thirty days, and pigeon eggs in seventeen days.

204. **How to Set a Hen.** Make a frame fourteen inches square and six inches high. Place it in the center of the combination sitting and brooding coop. Use as nesting material excelsior or fine hay. With the hand round out the nest well, so there will be no pockets in the corners for the eggs to roll into, and thoroughly press down the center, making a good U-shaped nest. Secure a hen that is broody and place her on the nest with one egg. Hang a burlap bag in front of the coop and on the second day take the hen off and feed and water her. If she goes back on the nest, she may be set on the following day. The sitting coop makes it possible to keep clean water and feed before the hen at all times and allow her to come off when she chooses. Dust the hen with insect powder when she is set and again when she is taken from the nest with chicks.

205. **The Kind of Hen That Makes the Best Mother.** The best mothers are the larger breeds, as the Rhode Island Reds or the Plymouth Rocks. The hen should be well-feathered and

of good temper. To determine if a hen is ready to set, place the hand under her; if she nestles over your hand, she is likely to make a good sitter and mother. A pullet does not usually make a good mother.

206. Sign of a Sitting Hen. When a hen becomes broody, she will be noted to stay on the nest longer than usual and in a day or two will remain on the nest all the time. She will now ruffle her neck feathers and cluck if disturbed.

207. Structure of the Egg. If an egg is boiled its structure can be studied. The parts from the outside inward are as follows: lime shell, outer and inner membranes, albumin, and yolk. The outer and inner membranes separate at the large end, forming an air cell. Two hard masses or shreds of albumin, called *chalazae*, are formed at the poles of the egg in the albumin. The yolk is surrounded by a delicate membrane. On the top of the yolk there is located the germ called the blastoderm. When an egg is laid, the yolk is nearly in the center of the mass of albumin. The yolk gradually becomes more superficial, until after a week there is only a thin layer of albumin between the yolk and the shell membranes. There is always a layer of albumin between the yolk and shell up to the twenty-first day.

208. How the Egg Is Formed. The yolk is formed in the ovary. The rest of the egg is formed in the oviduct or egg canal, which is eighteen to twenty inches long. In the first portion the albumin or white of the egg is formed; in a following portion the shell membranes are formed; and in a part still farther along the shell is formed; then finally the color is fixed.

209. When to Candle Incubating Eggs. It is best to set six hens at one time. Candle the white eggs on the fifth day and the brown eggs on the seventh day. If the egg is infertile it will be clear. These eggs are good for food and can be used on the home table, but should not be sold, since the shaking they must undergo in hauling will addle many of them. If they are not wanted for table use, keep them and later boil them

and feed them to the baby chicks. After the eggs have all been candled (185), count the infertile ones and estimate the percentage of fertility. It is well to candle eggs again on the sixteenth day. This is to remove the dead germs. At this time the air cell will be noticed to be very large; if the germ is dead, the air cell will be cloudy and the germ or chick will not be so large as the live chicks.

210. Eggs set in the incubator do not hatch as well as those set under hens. It is seldom that more than 50 to 65 per cent of all eggs placed in the incubator hatch. The greatest number of deaths occur during the latter part of the first week and during the latter part of the third week of incubation.

CHAPTER XVII

ARTIFICIAL INCUBATING AND BROODING

Note to Teacher: The student should study and make drawings of the various parts of an incubator.

211. **Artificial Incubation.** By artificial incubation is meant hatching eggs with an incubator.

212. **Artificial Brooding.** By artificial brooding is meant rearing chicks with a brooder.

213. **Kinds of Incubators.** There are small and large incubators. The small incubators are of various capacities, some holding sixty eggs, others 120, 144, 150, 200, and 240 eggs. The largest incubators are called mammoth because they hold from 1200 and 1800 to several thousand eggs.

214. **Fuel Used in Incubators.** The fuel used in incubators, both small and mammoth, is oil, gas, or coal, or electricity may be employed.

215. **Methods of Heating Incubators.** Incubators may be heated by hot water or by hot air through a diffusion diaphragm.

216. **Construction of the Small Incubator.** The small incubator consists of three essential parts: an insulated and ventilated box called the body, a heating device, and a heat-regulating device.

217. **The Body of the Incubator.** The body of the incubator is supported on legs. The heating device is attached to the side of the body, except in those incubators heated by electricity or by stoves.

The body is divided into three chambers: an upper, a middle, and a lower. The upper chamber is the heating apartment, and is separated from the egg chamber by a diaphragm in those incubators that are heated by diffusion. In the hot-water system

the chamber is occupied by pipes. These pipes are not separated from the egg chamber.

.The eggs occupy the middle chamber.



AN OIL-BURNING INCUBATOR.

Fig. 31. 1, body; 2, heat diffusion diaphragm lowered; 3, egg tray; 4, thermometer; 5, nursery tray partly drawn out; 6, lamp; 7, heating drum from which air passes into incubator; 8, glass door; 9, damper bar; 10, damper disc; 11, balance weight; 12, candler; this metal chimney is used with the incubator lamp in a dark room to candle eggs.

The lower chamber is provided with a canvas-covered tray, and is called a nursery chamber. A glass door is placed in front, so that the chicks, as fast as they are hatched, are

attracted by the light and, coming forward, drop down into the nursery tray.

218. Heat Necessary for Incubation. An incubator thermometer must be provided. The bulb of the thermometer should be at the upper level of the eggs. The temperature should be 103° F. at all times. If the temperature accidentally goes to 105° F. there is danger of killing the germs, and if it goes

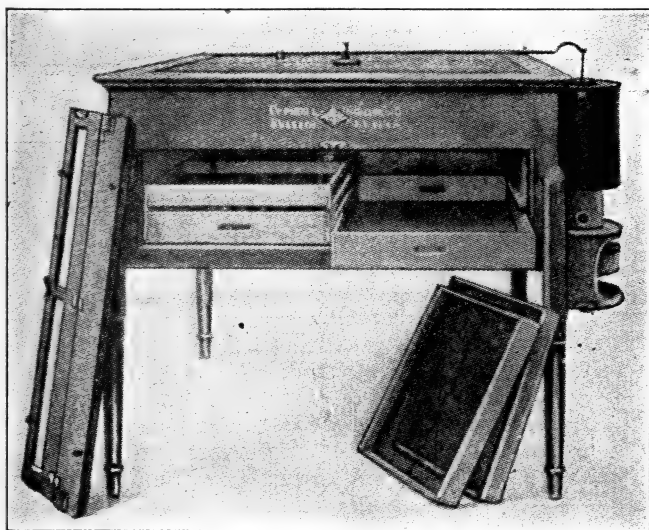

Fig. 32. Incubator with front removed. Egg trays and nursery drawers in place in left-hand side of incubator, and egg trays removed from right-hand side.

to 110° F. it is probable that all of the germs will be killed.

219. Leveling and Starting the Incubator. The incubator must be level. Do not put eggs in the incubator till you have it regulated to 103° F. and can hold it through the day and night at that temperature.

220. Care of the Eggs During Incubation. The eggs must be turned once a day after the third day. Eggs not turned

during incubation will not hatch. Do not turn the eggs after the eighteenth day. On the eighteenth day close up the incubator and do not open again till the hatch is over. Opening the incubator during the hatching may kill many of the chicks.

221. Candling Eggs. See 209.

222. Conditions Essential for Artificial Brooding. Dryness and a constant supply of fresh air are essential. An even and proper temperature must be maintained.

223. Kinds of Brooders. There are two kinds of brooders, indoor and outdoor. There are also heated brooders and cold brooders. Sufficient space and sunlight must be provided. Chicks must not be allowed to become chilled. Fifteen minutes of exposure to cold may result later in diarrhea, causing heavy losses and an unthrifty condition in those that survive. Small oil-burning hovers, with capacities of fifty, one hundred, or more chicks, may be purchased.

224. Construction of the Cold Brooder. The small cold brooder is usually made eighteen inches square and eight inches deep. A frame made of one-inch material is held by cleats at the upper part of the box. Three ventilating holes are bored at each side of the upper half. The upper half and lower half are hinged at the back. Over the inside frame there is stretched cheese cloth or muslin. On this there is placed a feather pillow or woolen quilt material. The muslin sags in the middle. The chicks keep warm by their own heat. The cold brooder has not come into general use owing to the danger of the chicks becoming chilled.

225. Deflector Hovers for Large Flocks. When flocks of 500 to 1000 are brooded together, large hovers with hoods made of metal and heated by coal stoves are used. The temperature under the hovers should be 100° F. for the first month and then gradually lowered.

226. A Special House for the Hover. A special house, six feet square, has been designed for the 100-chick hover. This

same house may be used as a range house for the chicks after they are eight weeks old and no longer need artificial heat.

227. List of Material for the Hover and Range House:

- Runners, 1 piece, 2x6 inches, 14 feet long.
- Sills, 2 pieces, 2x4 inches, 12 feet long.
- Plates, 1 piece, 2x4 inches, 12 feet long.
- Corner posts, 2 pieces, 2x4 inches, 12 feet long.
- Rafters, 4 pieces, 2x4 inches, 8 feet long.
- Front stud and door facing, 3 pieces, 2x4 inches, 12 feet long.
- Batten for door, 1 piece, 1x4 inches, 8 feet long.
- Four-inch flooring for sides, ends, front, and floor, 52 pieces, 12 feet long.
- Roost poles, and rests for same, 2 pieces, 2x4 inches, 12 feet long.

Hardware:

- Hinges for doors, 1 pair, 4 inches, for back ventilator; 2 pairs, 8 inches, for two front doors.
- Hasps for doors, 2 pairs.
- Rubberoid for roof, 64 square feet.
- Chicken netting, 1 piece, $\frac{3}{4}$ -inch mesh, 30 inches by 6 feet.
- Chicken netting, 1 piece, 1 foot by 3 feet, $\frac{3}{4}$ -inch mesh.
- Nails, 6d. wire, 3 pounds.

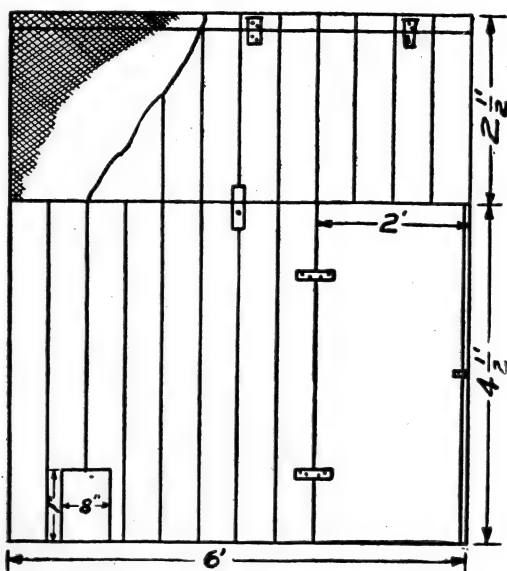

FRONT ELEVATION

**END ELEVATION****BACK ELEVATION**

Fig. 33. A house for a 100-chick hover and range house for chicks. The end elevation shows the position of the hover. After the chicks are eight weeks old, the hover is removed and perch poles are placed six inches above the floor for the chicks to perch on. This building is five feet high at the rear and seven feet at the front. The back elevation shows the ventilator and the front shows the position of the storm door, large door, and trap door through which the chicks pass out and in.

228. Notes on Construction. The front ventilator prevents driven rains from wetting the house. Chicks are allowed to run out when the weather is favorable. If this house is to be used in cold weather, a small window sash must be placed in the front close to the floor. This will allow light and sunshine in the house for the birds. The sash can be made to slide and the opening should be covered with three-fourths-inch chicken wire. This will allow the keeping of the window open on warm days.

The sills are placed on the two sled runners, made of two-inch by six-inch oak. This makes it possible to move the house from place to place. The sills are placed two feet apart and covered with flooring. There are four corner posts made of two-inch by four-inch lumber and a front and back plate of the same material. The rafters are placed two feet apart and covered with sheathing, which is covered, in turn, with rubberoid or shingles.

There is a ventilator in the back near the top of the building. This is covered with three-fourths-inch mesh netting and there is a door which opens into the room. This door is hinged at the bottom. The front wall has a thirty-inch door extending the entire width of the building and hinged at the top with three strong eight-inch strap hinges, so that it may be propped up as indicated in Fig. 33. The front has an opening at the floor level which may be closed at night, or there may be made a netting door. The front also has a door near the end so that one may enter the building. This arrangement prevents rain from drenching the house.

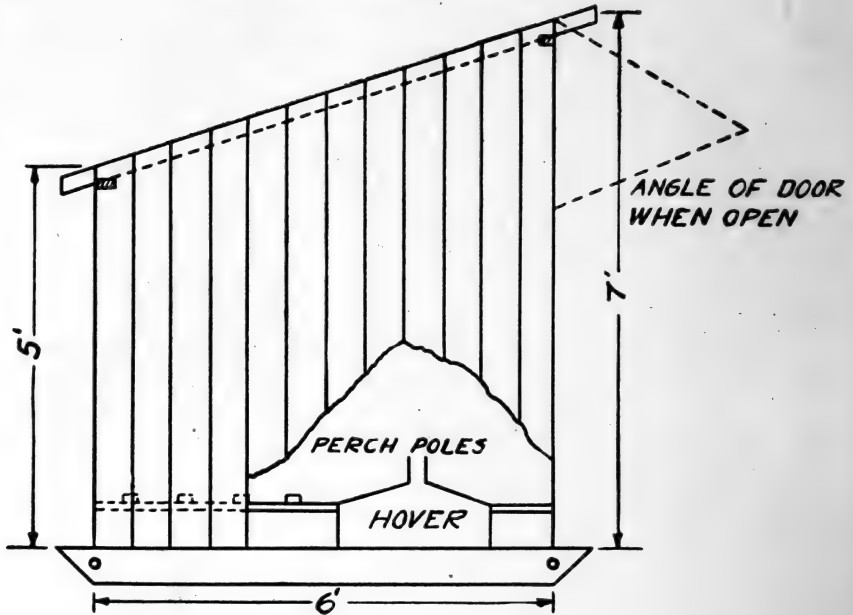
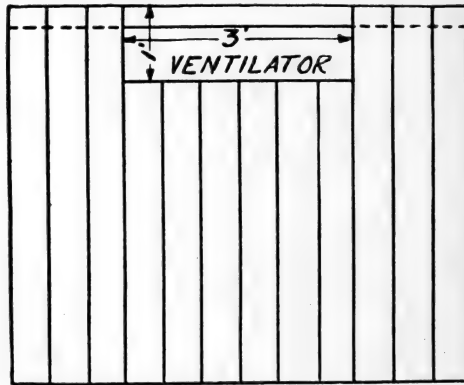
CHAPTER XVIII

FEEDING CHICKS, GOSLINGS, DUCKLINGS, AND POULTS

Note to Teacher: The student should be given exercises in mixing chick feed and in feeding chicks.

229. Feed Requirements for Chicks. Young chicks require about one pound of protein or muscle-building material to four of starches, sugars, and fats combined.

230. Mashers Necessary for Chicks. The amount of protein required by chicks makes the feeding of mill by-products and other by-products of high protein content necessary.

231. When to Feed the Baby Chick. Forty-seven per cent of the yolk of the egg is incorporated in the abdominal cavity in an abdominal yolk sac as abdominal yolk and is sufficient for the food requirements of the chick for more than three days after it is hatched. Do not feed the chicks till after they have been hatched seventy-two hours.

232. First Feed of the Baby Chick. The first feed of the baby chicks should consist of sour curdled milk or fresh buttermilk. This feed should not be given before the chicks are seventy-two hours old. In the case of incubator chicks, they should be taken from the incubator and fed some sour milk the third day after the first chick hatches. The second day the chicks should be given two light feeds in addition to the milk, and the third day they should be put on full feed. By following this method, the digestive organs are gradually brought into play and time is allowed to use the stored up food of the abdominal yolk sac. (Examine a baby chick just out of the shell, or one that has died while pipping out, for the abdominal yolk sac.)

The first solid feed for the baby chick may consist of some hard-boiled egg, mixed with bread crumbs, and made soft with sour milk.

After chicks are on full feed they should be given mash, mixed with sour skimmed milk or buttermilk, so prepared as to be crumbly, three times a day, and a scratch feed twice a day.

233. Formulas for Dry Mash:

Soybean meal	33 pounds
Corn meal	67 pounds
Peanut meal	33 pounds
Corn meal	67 pounds
Ground oats	28 pounds
Corn meal	28 pounds
Wheat middlings	28 pounds
Meat meal	16 pounds
Wheat bran	10 pounds
Wheat shorts	10 pounds
Corn meal	5 pounds
Meat meal	5 pounds

234. Formulas for Grain Feed:

Cracked corn	5 pounds
Hulled oats	5 pounds
Cracked corn	10 pounds
Cracked wheat	10 pounds
Pinhead oats	10 pounds
Cracked corn	5 pounds
Wheat screenings	10 pounds
Wheat	20 pounds
Hulled oats	15 pounds
Rice	10 pounds

235. Grit and Shell Essential. On the first day provide fine grit, such as sand. Keep this before the chicks at all times. as the gizzard must contain grit to aid in grinding the feed.

236. Fresh Water and Clean Dishes Essential. Fresh, clean, pure water must be kept before the chicks at all times. The water and milk containers must be scrubbed once a day. Spoiled milk and feed which has been allowed to lie around are a fruitful source of diarrhea.

237. Feeding Boards Required. Feeding boards one or two feet square on which the chicks may be fed are advisable. As soon as the chicks have finished eating, these boards should be scrubbed in a 4 per cent solution of some standardized coal tar disinfectant and allowed to dry before the next feeding.

238. Effects of Chilling. Do not allow the chicks to become chilled. If the chicks are with a hen, she will take care of them, but if they are brooder chicks, they must be put back under the hover as soon as feeding is over if the weather is cold. Chilling results in fatal diarrhea.

239. Effects of Overcrowding. Do not overcrowd the chicks, either those with the hen or those in the brooder. Do not overcrowd chicks on range. Disease and death always follow overcrowding.

240. Effects of Overheating. If chicks are subjected to high temperatures in the hover and then allowed to cool off quickly, sickness and heavy losses result.

241. Look Out for Cannibalism. Chicks often commence to eat each other's toes. Immediately remove the chick attacked. In such cases, the chicks need more protein. Give them exercise and plenty of meat meal and milk.

242. Dispose of Chicks That Have Had Diarrhea. Toe punch all chicks which have had a severe attack of diarrhea, and do not save them for breeding purposes, but sell them for broilers.

243. Chicks Old Enough to Range. As soon as chicks are old enough to range for their feed, give them grain morning and evening. Discontinue the wet mash and keep dry mash before them all the time. An outdoor mash hopper shown in Fig. 34 may be used.

244. **Wasting the Feed.** Chickens hook out some of the feed with their beaks and waste it. To avoid this, cut out a piece of one-inch poultry netting a little smaller than the inside of the hopper. Allow this to rest on the feed.

245. **Suitable Location for Rearing Turkeys.** An orchard or wood from which the underbrush has been cut makes an excellent range.

246. **Suitable Feed for Poultry.** Cottage cheese, buttermilk or curdled skim milk is excellent. Oats, corn, and wheat make good grain feeds.

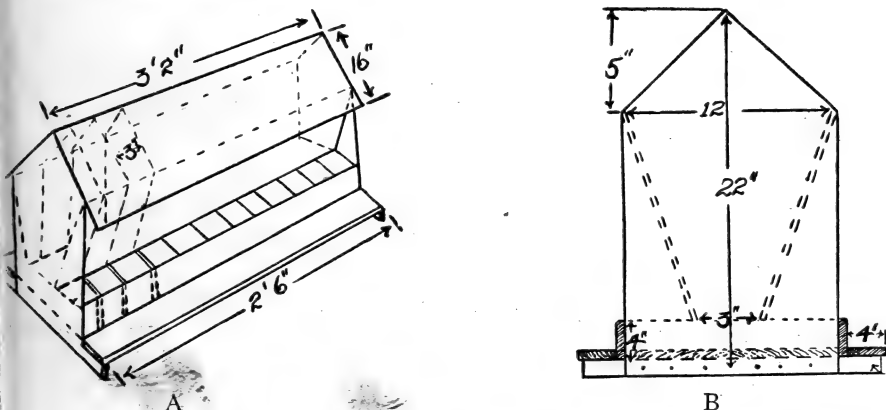

Fig. 34. A, angle view of an outdoor mash hopper. B, end diagram of same. This mash hopper is provided with three small compartments one for grit, one for charcoal, and one for crushed oyster shell. The large compartment is for dry mash.

247. **Grit Is Essential.** Young turkeys must have grit in the form of sand or crushed limestone.

248. **Must Be Free From Vermin.** Dust the hens when they are set and again when they are taken from the nest. Keep a lookout for lice and mites, as these parasites will kill the young turkeys.

249. **Feeding the Poult.** The first feed should be given the young poults seventy-two hours after the first poult has hatched. The first feed should consist of sour milk or buttermilk. On

the following day, the poults should be given a mixture of hard-boiled egg and soft bread crumbs. After the fourth day this may be replaced with hulled oats, cracked corn, and cracked wheat.

250. Rainstorms and Dew Fatal to Poults. Young turkeys must not be allowed to run in the grass when the dew is on or allowed to be in heavy rainstorms.

251. Mash Feed for Young Turkeys. Young turkeys should be given one of the mash feeds outlined under chick feeding (233). This should be given three times a day till they are eight weeks old. After that time the poults should be allowed to run to the dry mash hopper and secure their mash in dry form when they like.

252. Suitable Places for Raising Ducks and Geese. Young ducks and geese need a shady, grassy run and should not be raised with chickens or turkeys.

253. Feeds Suitable for Young Ducks and Geese. All feed given to young ducks and geese should be in a wet form, as dry feed may clog up the nose. Ducks should have plenty of water in shallow dishes. Green feed in the form of sprouted oats, short grass, or range grass is essential.

254. When to Feed Ducklings and Goslings. Young ducks and goslings should be fed on the third day after the first one begins to pip out of the shell. They should then be given four times a day ground feed mixture made wet with water. Do not give ducklings or goslings milk. They must have plenty of grit.

255. Good Feeds for Ducklings and Goslings:

Corn meal	2 pounds
Wheat bran	2 pounds
Beef meal	1 pound
No. 2 flour.....	1 pound
Green stuff	1 pound
Wheat bran	10 pounds
Wheat middlings	5 pounds
Corn meal	3 pounds
Meat or fish scrap.....	2 pounds

Corn meal	10 pounds
Wheat bran	10 pounds
Meat meal	4 pounds

256. The following is a list of materials for the outdoor mash hopper:

For ends, partitions, sides, and top, 2 pieces, 1 inch by 12 inches, 16 feet long.

For run board and piece by the side of the run board, 2 pieces, 1 inch by 4 inches, 12 feet long.

For base pieces, 1 piece, 2 inches by 2 inches, 12 feet long.

Rubberoid, 1 piece, 4 feet long by 34 inches wide.

Hooks and eyes, 3 inches long, for fastening down top, 1 pair.

Round $\frac{1}{4}$ -inch rods, 5 inches long, 20.

Nails, 7d., 2 pounds.

257. Notes on Construction of the Outdoor Mash Hopper.

The top is removable and is held down with two hooks and eyes so that the wind cannot blow it off. The top is made of two twelve-inch and two four-inch boards. It is braced with two pieces of two-inch by two-inch pieces at the outer edge of the mash hopper. The top is covered with rubberoid roofing tacked tight over all edges.

The ends are made of one-inch by twelve-inch boards and are nailed at the bottom to a two-inch by two-inch base, which prevents the mash from getting wet. The sides are made of one-inch by twelve-inch board and placed at an angle as indicated by the dotted line in Fig. 34, B. The partitions, three in number, are made of one-inch by twelve-inch board sawed at the same angle as the roof and sides. (See Fig. 34, A and B.)

The bottom is made of one-inch by twelve-inch board, two feet six inches long, and is nailed to the two-inch by two-inch base supports.

The run board is made of one-inch by four-inch board and is nailed to the base support. A strip, one inch by four inches, nailed to each end, prevents the mash from being wasted, and the bars are placed four inches apart at the feed opening.

CHAPTER XIX

FATTENING POULTRY AND SHIPPING POULTRY PRODUCTS

258. **Poultry Should Be Fattened for Market.** Hens and young birds intended to be sold in the market should be fattened before being marketed.

259. **Length of Time for Fattening.** The birds should be fattened fourteen days.

260. **Milk-Feeding Fattening Fowls.** Milk-fed fowls have a superior flavor, and in many markets, such as that of New York, dressed milk-fed broilers bring a premium of five cents a pound.

261. **How Poultry Is Fattened.** Hens or frying chickens are placed in small coops about thirty inches square and fed morning, noon, and night.

262. **How Much to Feed Fattening Chickens.** Fattening chickens are easily thrown off their feed; when once thrown off, they will not fatten well. Give just as much food as they will clean up in twenty minutes and then take away any left over. Do not let them have so much food that they get sick of it. Keep their appetite keen.

263. **What to Feed.** One part each of ground feed and two parts of buttermilk or sour skim milk give the best results. This makes a mixture of about the consistency of batter and must be fed from a trough.

264. **Feed Mixtures for Fattening Chickens:**

Corn meal	9.5 pounds
Wheat middlings	9.0 pounds
Red dog flour.....	8.3 pounds
Meat meal	2.5 pounds
Soybean meal	33 pounds
Wheat middlings	33 pounds
Corn meal	34 pounds

265. The following formulas are good mixtures for fattening hens :

Corn meal	24 pounds
Wheat middlings	6 pounds
Ground oats	4 pounds
Corn meal	2 pounds
Wheat shorts	1 pound
Ground oats	1 pound
Buttermilk	8 pounds

266. **Market Grades of Fowls.** In the market old hens are called fowls; old male birds, roosters or cocks; young chickens of $\frac{3}{4}$ to $2\frac{1}{2}$ pounds, broilers; of $2\frac{1}{2}$ to 4 pounds, fryers; of 4 to 8 pounds, roasters.

267. **How Live Poultry Is Shipped.** Live poultry is shipped in standard-sized shipping crates which can be purchased in the market.

268. **How Eggs Are Shipped.** Eggs are shipped in thirty-dozen case lots.

269. **To Whom Shipped.** Eggs may be shipped to wholesale commission merchants, who are usually located in the large cities.

270. **Cost of Shipping.** The cases will cost approximately thirty cents each for the case, flats, and fillers. The express costs will vary according to distance. The commission man will charge 5 per cent for selling. Eggs may be sold directly to consumers, clubs, hotels, restaurants, or city retail stores. This will save the commission man's charge of 5 per cent for selling.

TO PRESERVE EGGS FOR WINTER USE

271. **Kind of Eggs to Preserve.** Eggs for preserving purposes should be clean, fresh, not over three days old, and of absolutely sound shell, as cracked eggs are unfit. Infertile eggs are preferred. These may be placed in the liquid each day if desired.

272. **Kind of Container to Use.** A glazed earthen jar is preferable, though other containers, as galvanized or glass containers,

may be used. Do not use wood or any other material which may give off an odor to the liquid, as the eggs will absorb these odors and as a result will be given an objectionable taste. The container should be provided with a lid to prevent evaporation; or in case no lid is provided, a paper can be securely tied over the top to prevent evaporation of the solution. After thoroughly cleaning the container, scald it.

273. How Large a Container to Secure. Eggs vary so in size that it is impossible to give, in each case, the size of the container needed. The following, however, will accommodate average-sized eggs; one-gallon capacity for 40 eggs, two-gallon for 80, three-gallon for 120, four-gallon for 160, five-gallon for 200, ten-gallon for 400.

274. Waterglass Method. Waterglass (sodium silicate) may be obtained at any drug store at a cost of about fifty cents a quart. If the stores do not have it, a request should be made to order a supply.

275. How to Prepare the Waterglass Solution. Waterglass comes in bottles and is about the consistency of strained honey. Use one quart of the waterglass to nine quarts of clean boiled water. Mix thoroughly and allow to cool before pouring over the eggs.

276. Testing the Eggs. Eggs should be candled to determine if they are perfectly fresh and that the shell is not cracked. Do not use thin-shelled eggs or those which are dirty. Do not wash them before placing in the container. To test these eggs, use the candling device sent with any incubator, any commercial candler which uses an electric bulb or lamp, or a home-made candler made for the purpose.

Secure a box about the size of an ordinary shoe box, cut a hole at the end and one in the center of the side; set the box on end and place the lamp in it. The hole in the top should be directly over the top of the lamp chimney and the hole in the side should be directly in front of the middle of the chimney.

This latter hole is the one to be used in candling. Take this apparatus in a dark room, when, by holding the egg over the hole in the side of the box, the light from the lamp will be reflected through it. If the egg is fresh you will note a small air space about the size of a dime at the large end. If this cell is larger the egg is not fresh, as the size of this air space indicates the age. The balance of the egg should appear rather dark, with the central part the darkest, as this is the yolk and the light is not transmitted through it as freely as through the white. If there is a blind-check, you can detect the crack in candling.

277. How to Place Eggs in the Container. Place the eggs in the container with small ends down, as this end is the stronger. Place layer on layer till the eggs are within about two inches of the top of the jar. Now pour over the waterglass liquid, completely filling the jar, so that the top row is covered about two inches deep. Cover tightly to prevent evaporation.

278. Where to Place the Container. The container should be kept in a cool place, and where objectionable odors will not find their way to the jar.

279. Quality of Preserved Eggs. Eggs preserved by the waterglass method may be used in any form for the table and for cooking, except for poaching. They may be scrambled, boiled, and fried. In boiling it is best to puncture with a pin the large end of the egg so as to allow the air from within, when heated, to pass out, and thus prevent breakage. In taking eggs out of the solution, wash the jelly-like material off with clean cold water. Eggs may be taken out just as they are needed. Always remove them from the jar with clean hands.

CHAPTER XX

DIARRHEA IN POULTRY.

✓ 280. **Cause of Diarrhea in Baby Chicks.** Diarrhea in baby chicks may be due to allowing them to become chilled, as is often the case in raising chicks with a brooder. Fifteen minutes of exposure to severe cold while quite young may result in fatal diarrhea and the loss of many birds. When more feed is given than the birds will eat quickly, it often spoils and causes diarrhea. Stale milk and moldy feed are sources of trouble. Unsanitary utensils are dangerous; the water and milk containers must be cleaned out once a day. This is done best by using a brush or even the hand to rub the walls and the bottom of the container.

✓ 281. **Contagious Diarrhea of Baby Chicks.** A contagious diarrhea is due to a germ. This form affects the baby chicks as soon as they are hatched, and in the first week often as many as 80 per cent of them contract the disease and die.

282. **How Chicks Become Infected.** The baby chicks become infected by eating or drinking contaminated feed and water, or the hen that lays the egg may have an ovary that is diseased. A hen with an ovary infected with the germ of white diarrhea will lay eggs containing the germs and the baby chick will be infected when hatched.

283. **How to Tell When Baby Chicks Have White Diarrhea.** The disease appears within two or three days after hatching and heavy losses occur the first week: The bird shows the following signs of the disease: drooping wings, ruffled feathers, sleepy appearance, little or no appetite, abdominal yolk not properly absorbed, a whitish or whitish-brown frothy discharge from the bowel which adheres to the vent fluff, eyes closed part of the time, and a lack of interest in the surroundings.

284. **What to Do for White Diarrhea.** Keep the hover and run thoroughly clean. Disinfect once a week with a 4 per cent solution of some standardized coal tar disinfectant dip. Give the birds, in the drinking water, one thirty-grain tablet of sulphocarbolate compound. Each thirty-grain tablet should contain ten grains each of sulphocarbolate of sodium, sulphocarbolate of calcium, and sulphocarbolate of zinc. Fresh butter-milk is an excellent remedy.

285. **Disposition of Chicks With White Diarrhea.** All chicks that die should be burned. Toe punch all chicks with diarrhea and do not save them for breeders, but sell them for broilers as soon as they are old enough.

286. **Contagious Diarrhea Occurring at About Ten Days of Age.** A contagious diarrhea, caused by an animal organism called the *coccidium tenellum*, affects chicks later than the bacillary white diarrhea described above and causes the greatest death rate at from ten days to two weeks of age. The symptoms are much the same as in white diarrhea and the treatment is similar.

287. **Diarrhea of Adult Fowls.** Adult fowls suffer most from diarrhea due to contaminated water. Fowls may drink polluted water from a contaminated pool or the water pans may be allowed to become foul.

288. **What to Do for Diarrhea in Adult Fowls.** Diarrhea of adult fowls yields to the sulphocarbolate compound treatment (284). The permanganate of potash treatment is cheap and is very useful (129).

289. **Fowl Cholera.** Fowl cholera is a contagious disease. It is due to a germ.

290. **How to Tell Fowl Cholera.** In severe forms of the disease, the first signs may pass unobserved and the bird be found dead under the roost in the morning. If the disease is less severe, the first sign will be dullness and moping about. The bird will not eat; the feathers are ruffled. The bird becomes

prostrated, and the bowel discharges or droppings are of a yellowish-green color and semi-liquid. The comb is dark or even black, the bird walks with a swaying gait, trembles, and may even have convulsions. Most of the birds of the flock will die.

291. How the Disease Is Spread. Birds may contract the disease by coming in contact with other birds that have it. A bird sick of the disease may be introduced into the flock. A bird may be shipped in coops in which sick birds have been shipped. Birds may be placed in houses or runs where birds suffering with cholera have been kept.

292. What to Do for Cholera. Give the sulphocarbolate compound (284); keep permanganate of potash in the water (129). Thoroughly clean and disinfect the premises with a 4 per cent solution of any standardized coal tar disinfectant dip having a coefficient of at least one to five (1:5). Burn or bury in lime all birds dead of cholera.

293. Blackhead in Turkeys. There is a disease of turkeys called blackhead because the head and neck are supposed to turn black.

294. How to Tell When Turkeys Have Blackhead. The turkey appears sick, mopes about, eats little or nothing at all. The wings droop, the feathers are ruffled, and the bird sits around much of the time. It has a thin, watery discharge from the bowels of a greenish-yellow color. The bird gradually becomes poor and usually dies in a week or two.

295. Age at Which Turkeys Suffer Most. Turkeys fourteen to sixteen weeks of age are most likely to become affected and die.

296. How Turkeys Contract Blackhead. Turkeys contract blackhead by running with hens that harbor in their intestinal tract the single-celled animal parasites that cause it, though the hens themselves do not develop the disease. Turkeys also contract the disease by running with turkeys that have

chronic cases or by running on ground on which diseased turkeys have run before.

297. What to Do for Blackhead. Give the sulphocarbolate compound (284) and remove the birds to a clean woods run. Many shady runs should be provided if one is to raise turkeys. An abundance of buttermilk and good wholesome feed should be given.

298. How the Internal Organs Appear in a Turkey That Has Died of Blackhead. Open the turkey, and if it has died of blackhead the liver will be spotted, that is, covered with small round spots of dead liver tissue. One of the blind pouches (caeca) will be greatly enlarged.

CHAPTER XXI

MITES, LICE, SCALY LEGS, AND FLEAS OF POULTRY *

Note to Teacher: Have students study mounted specimens of parasites.

299. **What the Red Mite Looks Like.** Red mites vary in size from one-fourth of a pin head to a pin head. They vary in color from almost white to bluish-red and red.

300. **Where Mites Are Found.** Mites are found on the under side of the perch poles and in the cracks where the perch poles rest upon the support.

301. **When Mites Attack the Fowls.** The mites attack the fowls at night and leave them before morning, locating themselves on the under side of the perch poles.

302. **Effect Upon the Birds.** Mites suck the blood and where they are numerous they will kill young birds as well as old ones. They are often found in the brooding coop and in nests of sitting hens. In birds that are badly infested, the comb becomes pale and the bird weakens and finally dies.

303. **How Mites Multiply.** Mites multiply by laying their eggs in the cracks of the perch poles, on droppings boards, and even in nests. They multiply very rapidly in hot weather.

304. **How to Tell When Birds Are Infested.** Examine the under part of the perch poles, and if mites are present they will be observed in small clusters. There will be noticed white fuzzy material in the cracks. This material is the shed skins or molts of the young mites.

305. **What to Do to Rid the Birds of Mites.** Thoroughly clean the droppings boards, floor, and nests and sweep down

* For reference, see *Poultry Diseases*, published by *The American Journal of Veterinary Medicine*, Chicago, Ill.

the walls, then spray the house thoroughly with a 4 per cent solution of some disinfectant dip of a coefficient of at least five. Saturate the perch poles, on all sides and at the places where they rest on their supports, and the wall for a considerable space around with kerosene, carbolineum, or gasoline. Repeat this once every day till the mites disappear. Spray the house once a week till it is certain that no mites lurk around.

306. Lice of Poultry. There are one or more kinds of lice for each kind of poultry.

307. What the Louse Looks Like. The louse is light in color and rather thin and narrow. It is about five or six times as large as a full-grown mite and can be seen running around next to the skin of an infested hen.

308. How to Tell When Hens Are Infested With Lice. Catch the hen and push the feathers back the wrong way. Examine in the region of the vent and body fluff. If lice are present they will be observed.

309. Where Lice Are Found. When lice are present, they are always found on the birds unless brushed off accidentally.

310. How Lice Multiply. Lice multiply by laying eggs and cementing them to the feathers. Here they hatch in a few days and then soon develop into the adult stage, to multiply again. The eggs are laid in clusters and can often be seen on the web of the feathers, especially in the region of the vent.

311. How to Treat Hens With Lice. Birds with lice should be dusted with lice powder containing at least one-fourth of one per cent of free nicotine. This louse powder can be made as follows: Take two pounds of tobacco stems or leaves and place in a pan and cover with water. Boil for thirty minutes and pour off the liquid. Boil down this liquid to about one-half of a teacup. Put this into a half teacup of crude carbolic acid and add an equal amount of gasoline. To this mixture add plaster of Paris till the plaster is only slightly moist and pass the entire amount through a fly screen sieve. Use at once. This quantity

will take about two quarts of plaster. If "Black Leaf 40" can be secured or any pure nicotine such as is used by florists, add fifty drops to four ounces of gasoline and mix with plaster of Paris, as above, and pass through a fly screen. This latter makes a much better mixture and will take about one quart of plaster. Commercial insect powder can be purchased, but one should make sure that it contains at least one-fourth of one per cent of free nicotine.

312. Scaly Leg. Scaly leg is due to a scab-producing parasite.

313. Appearance of Scaly Leg. In scaly leg the affected shank is covered with thick scales. The parasites are found under these scales where they multiply.

314. How Scaly Leg Spreads. Scaly leg spreads from the introduction of an affected bird into the flock or from the placing of birds in quarters where scaly leg birds have been kept.

315. What to Do for Scaly Leg. Saturate the shank once every ten days with kerosene. Saturate the perch poles with kerosene or carbolineum.

316. Fleas of Chickens. The most common flea is the stick-tight flea.

317. How the Sticktight Flea Attacks the Bird. The stick-tight flea attaches itself to the skin of the head and upper part of the neck.

318. How the Sticktight Flea Multiplies. The sticktight flea multiplies by laying eggs which fall off and hatch on the ground. Sandy localities furnish the most favorable place for the multiplication of this flea.

319. What to Do for Birds Infested With the Sticktight Flea. Dip the neck in kerosene. Do not get the kerosene in the eyes of the bird. Lard mixed with a small amount of sulphur may be applied to the infested parts.

CHAPTER XXII

WORMS INFESTING POULTRY

320. **Internal Parasites.** Most of the internal parasites are worms. Small numbers of worms do not do any noticeable injury, but large numbers interfere with the health of the fowls and sometimes cause death.

321. **The Gapeworm.** The gapeworm, as it is taken from the wind pipe of an affected bird, is about one inch long, round in shape, and forked at the head end. The small worm is the male and the large worm the female.

322. **Injury Done by Gapeworms.** The gapeworms hold on to the mucous membrane lining of the windpipe or trachea and as they grow in size gradually close the opening so that it is difficult for the bird to breathe. As soon as sufficient obstruction takes place, the bird dies for lack of oxygen (83). The gapeworms also suck blood.

323. **How the Worms Multiply and Spread.** The female produces eggs, which are scattered over the ground. Other birds eating contaminated food or drinking contaminated water become infested. The worms at this stage are very small and burrow through into the windpipe, where they accumulate in clusters and gradually grow as described above.

324. **How to Prevent the Spread of Gapeworms.** Be sure that every gapeworm is destroyed by burning.

325. **How to Treat the Affected Bird.** Double a horse hair, or strip all the barbs off a feather except the tip, and pass it down the windpipe (trachea) as far as possible and withdraw it, at the same time giving a twist as you do so. Usually the worm will be brought out.

326. **Tapeworms of Chickens.** There are several varieties of tapeworms that infest the small intestine of the fowl.

327. Structure of Tapeworms. The tapeworm consists of a head, neck, and body. The head is slightly larger than the neck and is provided with suckers, and, in some varieties, with small hooks with which it holds on to the intestinal wall. The neck in some varieties is short and in others it is long. The segments which make up the body grow from the lower end. Each segment is a complete individual within itself, fertilizing itself, obtaining its own food, and maturing hundreds of eggs. As fast as the segments at the end of the worm are filled with fully developed eggs, they detach themselves and pass out to contaminate the feed and water consumed by other fowls, thereby infesting them. The tapeworm has no digestive tract. It lives by absorbing the digested nutrients of the intestines in which it grows.

328. Size of Tapeworms. Tapeworms of fowls vary in size from those just large enough to be seen to worms three or four inches in length and an eighth to one-fourth of an inch wide.

329. The Intermediate Host. Some of the tapeworms pass a part of their life in other parasites or animals; among these intermediate hosts are house flies, snails, and earth worms. The fowls devouring these worms and insects containing the larvae become infested.

330. Treatment of Birds Infested With Tapeworms. To each fifty birds use one-half pound of finely chopped tobacco stems. Steep the tobacco in hot water for two hours and mix with mash. Two doses should be given two days apart. The treatment should be administered in the morning on an empty crop and no feed should be given during the day of the treatment. The birds treated should be moved to houses and yards free from the infestation. The yard can be disinfected by using one gallon, one to one thousand bichloride of mercury, to each ten square feet of space. The houses should be thoroughly cleaned and the same solution used in them as on the ground.

331. Effect of Large Numbers of Tapeworms Upon the Bird.

Tapeworms rob the bird of food nutrients. The bird becomes unthrifty, the feathers are ruffled, it loses flesh, does not eat, has a deranged digestion. Growing birds are stunted, while laying hens fall off in their yield of eggs.

332. The Large Round Worm. The large worm infests the small intestine. It is about two inches long and white in color.

333. How the Large Round Worms Multiply. The large round worms multiply by laying eggs which pass out with the droppings. The feed and water become soiled and other birds eat this soiled feed and become infested.

334. Conditions Produced and Treatment. The conditions produced are similar to those observed for tapeworms (331) and the treatment should be the same (330).

335. The Small Round Worm. The small round worm is found in the blind pouches (caeca). Large numbers of them will produce similar symptoms to those produced by other worms (331). This worm is round in shape and white in color. Its method of multiplication is the same as that of the large round worm (332). The treatment should be similar to that for tapeworms (330).

CHAPTER XXIII

POULTRY AS AN IMPORTANT ENTERPRISE ON THE FARM

336. **Importance.** The growth of poultry and egg production on business lines in the United States during the past two decades has been remarkable. No class of live stock is so universally raised as poultry. Eggs are very high in the life-giving principal, vitamine, and are being used more and more in view of the high price of other meat-food products. The products of poultry rank in value next to those of the dairy or to the animals slaughtered for food. About one-sixth of the total value of animal products in the United States is credited to poultry. The demand for poultry and eggs has increased much more rapidly than the supply. With the close application of business methods in marketing farm products, and the keeping of more poultry on a single farm or marketing through clubs, the excess of better poultry products can be put on the market to an advantage.

337. **Opportunities.** Poultry raising as a department of the farm can be successfully carried on in connection with orchards, as in fruit growing; in cultivated lands, as in corn or cotton, or in fields where other large plants are grown; and in connection with pastures. Poultry have been turned into vineyards, after the crop is harvested and until next year's blooming time. In these vineyards, the chickens devour bugs and other insects which prey upon the bushes, trees, and plants. Many orchardmen keep chickens in their orchards, in small flocks, to consume the worms and other insects that destroy the fruit. Usually these flocks consist of about twenty-five birds, or about five birds per acre. Often portable houses are provided for chickens

in fields where the grain has been removed. The birds devour the insect life, manure the ground, and protect the next year's crop by destroying insect life, which would have otherwise hibernated to do damage the following year. One hundred hens will void one and one-half tons of droppings a year. Each ton of poultry fertilizer is worth, at the present price, \$25.00.

338. Poultry in Connection With Dairying. Poultry and dairying go hand in hand. In a dairy there is usually much waste skim milk, and, at times, buttermilk. Milk makes quick growth in chicks. Recently the North Carolina Experiment Station demonstrated that chicks fed ground feed, mixed with milk, made 30 per cent greater growths than other flocks fed the same ground feed without milk. The Indiana Experiment Station recently showed that hens fed ground feed and grain and no milk or animal food laid an average of 59.35 eggs per hen per year, while other flocks fed the same ground feed and grain and milk averaged 183.5 eggs per hen per year.

339. Utilization of Waste. The waste of foods from the table and kitchen is often sufficient to keep a dozen hens. On the average hundred-acre farm there is enough waste in yards and around the barn and nearby fields to more than supply one-half the food for fifty hens.

340. Little Capital Required on the Farm. On the farm poultry raising can be begun with little capital. An old building may be remodeled at a small cost, or much of the framing material can be secured from the farm woodyard, and oftentimes logs may be hauled to nearby sawmills and sawed into boards for the construction of poultry houses. The flock can be originated in the fall by buying some good birds, or baby chicks may be purchased in the spring and a flock of pullets be raised during the summer months. If the farm has a flock of mongrels, eggs from pure-bred flocks may be purchased during March and April and a flock of pullets raised for the next year's breeding and egg production. In this case the cockerels, being pure bred,

can be sold at more than food prices as breeders, the culls being used on the family table.

341. Relation of Profit and Investment. There is no branch of live stock that gives such quick returns as poultry. Pullets hatched in the spring, if properly cared for and fed, will be in full laying condition in six or seven months and, if properly housed and fed, will lay all winter when eggs are high-priced. Poultry raising is a branch of live stock production that can be adapted both to men and women or to boys and girls. Modern facilities make marketing easy. According to the 1910 census, the average income from poultry from each farm in the United States was \$92.39. It is no doubt much more now. There is no reason why several hundred dollars cannot be made on every farm each year from poultry, in addition to the supply of a part of the meat food for the table and clothing and groceries for the family, since eggs and poultry are traded at the country store for these commodities. The New Jersey Experiment Station has shown that the farm income from poultry for capital invested and labor given was greater than for dairy, truck, or general farming.

342. Requirements for Success. The requirements for success may be summed up in a few words, as follows: the culling of the flock each year; the keeping of profitable hens only; the keeping of vigorous males with good capacity; proper houses, care, feed, and range; the hatching of pullets at the right time of the year for winter laying.

343. Utilization and Distribution of Labor on the Farm. Small flocks can be kept with very little extra labor by so arranging the poultry work as to have it come in the list of chores. Where small flocks are kept, hatching can be done with the hen by using the combination sitting and brooding coop, so that the hen needs attention but once a day while hatching and three times a day while brooding. The chicks, after they are weaned and turned on range, should be given dry mash in an outdoor

mash hopper and grain and water three times a day, and the laying and breeding stock should receive like attention, using in this manner chore time in which to do the poultry work. This department of the farm will give the largest return for the time spent on it. Where poultry raising constitutes a main department of the farm more time will need to be apportioned for it, but if correctly planned and carried out, it will pay a good profit.

344. Tenant and Landlord's Shares Where Poultry Are Raised in Partnership. From data collected by the North Carolina Experiment Station, the following division will be about equitable: In cases where the landlord furnishes all the feed, he is entitled to 50 per cent of the returns when all the feed is purchased in the market. In cases where the landlord furnishes the land, buildings, equipment, and pays the taxes and other land costs, he is entitled to 25 per cent of the returns; where the tenant furnishes the breeding stock and all the labor, he is entitled to 25 per cent of the returns. Where the landlord and tenant pay equally for the feed and other supplies are furnished as above outlined, then they should share equally the returns from the sale of eggs, birds, and the young stock.

345. Labor and Return of a Hundred Hens as Compared to a Family Cow. Warren estimates that the amount of labor required to care for a family cow would amount to a man's work for fifteen days, and a horse's for two days. Elliot and Brown estimate that the returns from this one cow would be approximately \$70.60. The North Carolina Experiment Station has found that 100 hens will require about eighteen days' farm labor a year and two horse days, and should bring in a net revenue of \$1.80 per hen, or \$180.00. It requires approximately nine pounds of feed and 0.12 of an hour's labor to produce a dozen eggs. Two hundred to two hundred and fifty hens can be kept in one flock with very little more labor than a hundred hens. The following summary is taken from the records of the North Carolina Experiment Station:

A Small Commercial Flock Owned by J. E.

Average number of hens for the year.....	233
Total cost of feed for the year.....	\$ 598.51
Incidental expenses for the year.....	38.95
There were laid during the year.....	32,877 eggs
The total gross receipts for the year were.....	\$1,159.79
Twenty days' labor at \$2.50 per day would be.....	50.00
The house and equipment cost.....	250.00
Six per cent for deterioration would make.....	15.00
The gross income per hen was.....	4.97
The interest at six per cent-on money invested in feed was....	35.88
The net income per hen was.....	1.80

CHAPTER XXIV

SUGGESTIONS FOR PROJECTS AND LABORATORY EXERCISES

Suggestions for Project Study

Note to the Teacher: These are mere suggestions. It is intended that the teacher shall make the detail outlines to suit local conditions.

Two Major Projects (160 Hours Each)

1. To raise twelve pullets.

- Secure 4 hens.
- Make combination sitting and brooding coops (193).
- Select suitable eggs (197).
- Feeding and care (232).
- Select for vigor (53).
- Select for mating the following year (47-53).

2. To care for the home flock.

- Cull hens (61-79).
- Reconstruct house or construct new one (89-106).
- Construct poultry house equipment (98-106).
- If in the country, birds on range.
- If on town lot, fences and fencing (107-123).
- Rotation in green feed (158).
- Feeds and feeding (138-158).
- Grading and marketing eggs (173-188).

Project earning report for the year 19—.

Time covered by project, _____ to _____.

Inventories:

Beginning of project..... \$ _____

End of project..... \$ _____

Paid self for labor, _____ hours at _____ cts. per hour, \$ _____.

of which \$ _____ was cash.

Expenditures and receipts:

Total expenses (inventory, all labor, etc.)... \$ _____

Total receipts (inventory, prizes, etc.)..... \$ _____

Net profit \$ _____

Gross profit, including amount paid self for labor \$ _____

of which \$ _____ was cash, as above stated.

Chief source of gain _____.

A Demonstration Project

(Double Major if Done by Student at School Requiring
Two Years to Complete)

- School project showing results of crossbreeding (60).

Two Minor Projects (80 Hours Each)

- To raise ten capons.

Select suitable cockerels as to age, size, and breed.
Caponizing.
Care and feeding.
Fattening.

Minor No. 4 can be used in conjunction with Major No. 1.

- To raise sufficient mangels, collards, or cabbage for the flock for winter feed (158). Estimate one-half pound green feed for twenty-five birds per day for the months when no green feed can be had from the field.

Minor No. 5 can be used in conjunction with Major No. 2.

Laboratory Practice

The following suggestions for additional laboratory exercises are given to meet the need where more time can be devoted to poultry study than that indicated in the body of the text.

The number following each topic refers to the reference textbook in which the student should look up the subject.

- before the number indicates *Poultry Culture, Sanitation and Hygiene*.
 - before the number indicates *American Standard of Perfection*.
 - before the number indicates *Poultry Diseases*.
 - before the number indicates *Anatomy of the Domestic Fowl*.
- Where no letter is given the reference is to this text.

- Clean and spray house. Mix spray and study spray pumps (c-3).
- Visit poultry show. Study breeds and quality of individual birds and compare same breeds with your birds (b-all).
- Hold school or inter-school poultry and egg show (a-25, 27).

4. Harvest litter and other poultry materials as feed.
5. Cull and market non-producing hens from nearby flock (61-80).
6. Cull young stock of your own or nearby flock (45-53).
7. Dig and store root crops (158).
8. Feeding a flock for egg production (170-171).
9. Mate up breeding pen (45-50).
10. Study incubator and make drawings of same (213-218).
11. Study hover and make drawing of same (a-24).
12. Construct nests (104).
13. Make insect powder and dust hens (311).
14. Mix feeds for flock (170-171).
15. Candle and grade market eggs (185-188).
16. Visit flock. Each student should compare good birds of his breed with those of others (b-all).
17. Study parts of hard-boiled egg (207).
18. Fattening, killing, picking, and trussing (a-27 and 264).
19. Caponizing (a-25).
20. Draw plan for colony house: make list of material and estimate cost (a-6), (92 to 100).
21. Make outdoor mash hopper (256-257).
22. Make combination sitting and brooding coop (192-194).
23. Make droppings box and scrape (105-106).
24. Study egg cases, egg cartons, shipping crates for live birds, and other equipment (a-25).
25. Make feeding boards and hoppers for small chicks (237).
26. Remodeling a nearby poultry house (91).
27. Dissect and study digestion and egg-forming organs of a hen (d-175), (135).
28. Judging fowls (b-all).
29. Records and accounting (a-28).
30. A study of diseases, such as sorehead, roup, and blackhead (125, 280, 299, 301, 320).
31. To put up a fence correctly (119-120).
32. To lay paper and shingle.

Skills to Be Verified and Judged by the Teacher

1. To catch and hold a fowl correctly.
2. To take a broody hen from the nest and place her in a broody coop.
3. To handle small chicks, mark them for identification, and put on leg bands.
4. To enter and work in a house or pen without disturbing the fowls.
5. To clean and disinfect drinking utensils.
6. To distinguish sexes at an early age.
7. To tell a pullet from a hen.
8. To identify the common breeds.
9. To estimate the weights of fowls.
10. To evaluate and identify the common feeds.
11. To keep a correct egg and feed account.

12. To test eggs incubating for fertility.
13. To put down eggs for winter use.
14. To mark eggs for identification.

**Diary of Andy Jackson, Junior Poultry Keeper,
West Raleigh, January, 1919**

		DR.	CR.
Feb.	1.	Bought from Exp. Station, 50 S. C. Rhode Island Red eggs.....\$	6.00
		Left for incubation at station.	
	7.	Visited and tested eggs and found 5 infertile.	
	14.	Culled out 2 more eggs.	
	21.	40 eggs hatched.	
	22.	Borrowed 3 broody hens from Mother.	
	23.	Paid for incubating and carrying chickens	1.50
	24.	Mixed chick feed in sour milk.	
		Cost of feed.....	1.50
		Made 2 water fountains.....	.50
		Made 3 coops.....	2.00
March	1.	Bought 50 more S. C. Rhode Island Red eggs	6.00
		Left to be incubated.	
		Bought feed	5.00
	21.	35 eggs hatched. Paid for incubating.....	1.50
		Cleaned and painted coop with carbolineum50
		Moved first lot to alfalfa range.	
		Installed second lot in coop.	
April	1.	Built 2 colony houses.....	5.00
	15.	Separated cockerels from pullets.	
May	1.	Caponized 20 cockerels, borrowed instruments.	
Nov.	1.	First pullet laid egg.	
Jan.	1.	Sold 15 capons, weight 8 pounds each, at 50 cts. pound.....	\$ 60.00
		Inventory: 20 pullets at \$2.00 each.....	40.00
		5 cockerels to sell as breeders at \$3.00 each	15.00
		\$ 29.50	\$ 115.00
Profit for year's venture, \$85.50.			

CHAPTER XXV

A FEW OF THE MORE COMMON QUESTIONS THAT MAY BE USED FOR STUDY AND REVIEW

CHAPTER I

1. What are the principal purposes for which poultry is kept?
2. Has America been prominent in the development of the world's poultry? Name some breeds developed in America.
3. From what sources does the supply of poultry and poultry products of the large cities come?
4. At what time of year are the bulk of the broilers raised?
5. What means are employed to assure an even supply of broilers to city people the year round?
6. How much money do the poultry products of each year represent?
7. Are there any means provided for fattening, dressing, and refrigerating poultry on a large scale? Discuss fully.
8. When thousands of cases of eggs accumulate at the large storing and distributing centers, what is the most economical way of shipping to other large consuming centers?
9. What class of people consume most of the water fowls and where are there large duck farms?
10. What country holds the record for the largest number of eggs laid by a single hen in a year? How does America rank?

CHAPTER II

11. Is there any difference in the structure of the feathers of the various plumage parts of the male bird? Discuss this difference.
12. Discuss the different types of combs and examine the birds of the different breeds you have in the flocks, noting the kind of combs each breed has.

CHAPTER III

13. What is meant by standard-bred fowls?
14. Who determines which fowls shall be recognized as standard?
15. What is the American Standard of Perfection?

16. If you are told that a certain bird is of the American class and that it is a Barred Plymouth Rock, which of these words indicate class, which breed, and which variety, and what is meant by class, breed, and variety?

17. Name some of the fowls which are most popular and give a reason why these birds and not others are prominent.

CHAPTER IV

18. What are the various purposes for which birds are kept? What reason can you assign for the non-combination of all these qualities in one breed?

19. Which breeds are bred most for high egg production? Are these birds the most economical? Give reasons for your answer.

20. Is high egg production transmitted by both male and female fowls? What proof have you for your answer?

21. Name the best meat breed and give reason for your answer.

22. Which are the most common utility birds and why? What is a utility bird?

23. In selecting a male for breeding, name some of the points that denote good vigor. What are some of the points that denote poor vigor?

24. What are some of the indications of a good hen for breeding purposes?

25. If you have a flock of pure-bred birds but the average number of eggs produced is below a hundred, how would you go about raising the average of the flock from year to year?

26. What are the principal objects of poultry breeding on the farm?

27. If you are going to mate birds and the hens have been running with males from which you do not want chicks, how long will you have to wait after making the new mating before you save eggs for hatching? If hens have not been mated, how long will you have to wait?

28. If you cross a Leghorn male on Brahma hens, what will be the result of the crossing? Is this crossing advisable? Give reason for your answer.

CHAPTER V

29. At what time of year should hens be culled? Give reason for your answer.

30. If you are culling hens in August and one hen has old plumage, another is in full molt, and a third has an entirely new coat of feathers, how would you rate them as to high egg production,—that is, which

would be the highest producer, which next highest, and which the poorest? Would you sell any for food, and if so, which ones?

31. What are some of the signs of a poor producer? of a high producer?

32. If a Single-Comb White Leghorn has a bleached beak and shanks at least how many eggs has she produced?

33. Why does the abdomen enlarge as a hen comes into laying? If a hen measures four fingers in capacity and three fingers in pubic span about how many eggs should she lay?

34. What is the appearance of the comb and wattles of a laying hen? of one not laying?

35. If one pullet begins to lay at five months of age and another at eight months of age, estimating egg production from November 1 to November 1, which will lay the greater number?

36. What is a vacational molter?

CHAPTER VI

37. What will be the effect upon the birds if kept in a house insufficiently ventilated? Give reason for answer.

38. What is carbon dioxide? What will happen if the body does not get rid of it?

39. What method of ventilation will give the purest air? Why?

CHAPTER VII

40. What changes would you make in remodeling a house where the roof leaks; the ground is lower than the outside ground; there are no ventilating openings; the house is not battened; has cracks on all sides and faces the north?

41. Describe the different kinds of floors that can be used in constructing a new poultry house. Which is the most durable?

42. What is meant by an open-front house?

43. Why should the perch poles be loose?

44. What advantage is the water rack?

45. How many feet of perch pole space will you need for fifty birds?

CHAPTER VIII

46. Name the poultry house equipment and tell what advantage is it to have a house fully equipped.

47. What advantage is it to have a grain storage bin that holds 100 pounds?

CHAPTER IX

48. What makes the most durable post? Why?
 49. How can you make a wood post more durable?
 50. A post hole was dug thirty inches deep, the post put in and hurriedly filled in with dirt and tamped thoroughly on top. It was found that the post was loose. To what was the looseness due?
 51. What kind of poultry wire is the most durable?
 52. How would you handle poultry on a town lot?

CHAPTER X

53. What disease is likely to appear among your flock in the fall?
 54. A bird is poor in flesh, has an offensive discharge from the nose, a swelling below the eye, and feathers ruffled. What is likely to be the disease? Give the treatment.
 55. A bird has sores on its comb, face, and wattles. What is the disease and treatment?
 56. Among the birds that have a discharge from the nose there are found some birds having sores in the mouth, with an accumulation of cheesy material. Name the disease and treatment.

CHAPTER XI

57. What is the name of the storage reservoir at the base of the neck where the feed is stored? (This is noted after a bird eats a full meal.)
 58. In opening a fowl two long blind pouches are found. What is the name of these pouches?
 59. A loop of the intestine has lodged between it a long whitish gland. What is the name of this gland?
 60. In examining the internal organs there is found a large, round, thick-walled structure containing feed and grit. What is the name of this organ? A small organ lying close to the liver is observed. What is its name?

CHAPTER XII

61. Ohio Bulletin No. 291 reports an experiment on the value of range for hens. One of the trials gave the following results for a period of 882 days:

	Mortality.	Cost of Feed Per Hen.	Eggs Per Hen.	Value of Eggs Per Hen.
Confined	23.23%	\$1.96	241.1	\$4.22
On range	15.53%	1.97	278.3	4.85

What was the difference between the value of the eggs on range and confined? How much would this amount to in a flock of fifty hens? How much range should be provided for fifty hens? Suppose you were to consider the difference in the value of the eggs produced as rent for the range, would this be a satisfactory rent for the land? From the table given, what other advantage do you see in the range?

62. What is the relative value of meat scrap, fish scrap, and skim milk for laying hens? (See Purdue University Agricultural Experiment Station Bulletin 182.)

63. From the results of experiments, would it pay better to feed buttermilk to poultry or to hogs?

64. In what sections of the United States were prices of poultry and poultry products highest for the ten years' average from 1902-1911? In which states highest? (See Warren's Farm Management, p. 576.)

65. What evidence can you find that pure-bred poultry pays better than mongrels or crosses?

66. What are the three nutrients required in poultry feeds?

67. Why is it necessary to feed mash in addition to grain feed?

68. How do peanut meal and soybean meal rank as poultry feeds?

69. What is likely to be the result if you feed 30 per cent of velvet bean meal in mash?

70. If spoiled table scraps are fed to chicks, what is likely to be the result? Suppose the table scraps are fresh: what will be the result?

71. If you raise mangels for winter feed, when should they be planted, when harvested, and how kept till winter?

CHAPTER XIII

72. Hens have diarrhea with a greenish-yellow discharge; in looking around the place foul water containers are found. What effect, if any, might this have upon the health of the birds?

73. A flock of birds are fed irregularly, sometimes at six o'clock in the morning, at other times at nine, at other times, not at all. They are given similar treatment in the evening. What effect will this have on egg production? Note the behavior of a flock about feeding time.

74. Why is it necessary to feed mash with grain feed?

75. If hens are on range on a farm, will they get feed that will take the place of the meat scrap of the mash? What is it?

76. If birds are underfed, what effect will it have upon their laying?

77. Name the grains used for scratch feed; the feeds used for mash.

CHAPTER XIV

78. How much money is estimated to be lost each year from the careless handling of eggs? Where does most of this loss occur? What can be done to prevent it?

79. In flocks where you do not want to save eggs for hatching, is there any advantage in not having males with the hens?

80. What is the simple method of grading eggs for market?

81. Cases of what size are most economical for handling eggs?

82. What is the danger of hauling eggs in a farm wagon over rough roads?

83. What is the best way of shipping eggs for hatching?

84. What is meant by blind checks, checks, dents, and leakers?

85. An egg under the candler shows an air cell the size of a dime: of what age is the egg? Another shows an air cell as large as a quarter: of what age is this egg?

86. What is the advantage of marketing eggs in clubs?

CHAPTER XV

87. Chicks are hatched by an incubator: is this natural or artificial incubation?

88. What are the advantages of the combination sitting and brooding coop on the farm?

CHAPTER XVI

89. Eggs for hatching were separated into two lots: in one were uniform, well-shaped, large eggs; in the other were round, long, and thin-shelled eggs; others with ridges around them, under-sized, some abnormally large and some short. Which group is best for hatching purposes?

90. John Smith has some eggs he has been saving for hatching; he has some broody hens on the laying nests; he collects the eggs every day, sometimes every two days, and the eggs are twenty-five days old and have been kept in a warm room. Are these eggs suitable for use as setting eggs?
s

91. If you want to raise fifty pullets, and estimate that half of the chicks raised will be pullets, how many eggs will you need to set to produce the required number?

92. You wish Leghorn pullets to begin laying in the fall when eggs are high-priced. When should you hatch the chicks to produce these fall and winter laying pullets?

93. You have two hens that want to sit,—one a small hen like a Leg-horn, another a large, well-feathered hen. Which will make the best sitter and mother?

94. What are the signs that tell you when a hen wants to sit?

95. What are the different parts of an egg and where is each part formed?

96. In candling eggs, on the fifth day one egg appears clear and another looks as if a spider were in the center: tell about each egg. On the sixteenth day in candling, the air cell is large but clouded and the dark mass within is not quite so large as in another egg which has a clear, large air cell: tell about each of these.

97. Can you expect as large a hatch with an incubator as with a hen?

CHAPTER XVII

98. If you put two hundred eggs in an incubator, how many chicks should you expect?

99. Describe the construction of an incubator. How do you prepare the machine for operation and at what temperature should it be run?

100. Mrs. Jones ran her incubator with even temperature but did not turn the eggs during incubation: will any of the eggs hatch?

101. You are going to run a two-hundred-egg incubator and produce three consecutive hatches. What size brooder and how many brooders will you need?

CHAPTER XVIII

102. When should the chick receive the first feed and why?

103. Mr. Smith wishes to grow his Rhode Island Red chickens to 1.5 or 2 pounds weight by the end of eight weeks, but has nothing but corn, oats, and wheat screenings to feed them from the time of hatching: is it necessary for him to secure other feeds to make this forced growth, and if so, what mixture do you recommend?

104. A small flock of chicks were fed and then allowed to stay outside the hover in cold weather for an hour, becoming chilled: what was the probable result?

105. If chicks are allowed to eat feed that has lain around and become sour, what is likely to be the result?

106. Is grit necessary, and if so, why?

107. What kind of feed will you give to young poults? goslings? ducks?

CHAPTER XIX

108. What is the usual length of time of fattening fowls for market?

109. Is there any advantage in feeding fattening birds buttermilk?

110. Mr. Brown began fattening his broilers by giving them an extra amount of feed, allowing a surplus to lie in the trough before the birds at all times: his birds were off feed and did not make satisfactory gains. Was there anything wrong with his method of feeding?

111. How is live poultry shipped to market?

112. How are market eggs prepared for shipping and what are the costs of marketing?

113. Is there any advantage in preserving eggs for home winter use?

CHAPTER XX

114. What are some of the most common causes of diarrhea in chicks?

115. What is white diarrhea? How do you tell it? How do chicks become infected, and what is the best thing to do to stop it?

116. Mr. Osborne went to a friend's poultry yard where the hens were dying of fowl cholera and handled the birds, besides walking around in the yard. Was there danger of his carrying the disease to his flock?

117. How can you thoroughly disinfect a poultry house and yard?

118. How can you raise turkeys so that they will not have blackhead?

CHAPTER XXI

119. A flock of birds have pale faces and combs; some have been found dead under the perch poles in the morning; the birds' feathers are ruffled, and a fuzzy white material is noticed in the cracks of the perch poles: what do you suspect to be wrong and what further investigation is necessary?

120. How do you examine a bird for lousiness? How do you treat lousy birds?

121. Where do lice multiply? mites?

122. A hen has thick scales on her legs and presents an unsightly appearance: what is likely to be the trouble and how do you cure it?

123. A chicken has a few small black objects sticking to the unfeathered part of the head and neck: what are the parasites and what is the treatment?

CHAPTER XXII

124. In dressing a chicken, a round worm about two inches long and white in color is found in the intestine: what is this worm and is the meat of the chicken fit for food?

125. How do worms multiply? How do birds become infested with them? How do you get rid of worms?
126. What is the structure of a tapeworm, and does a tapeworm eat?
127. How do birds become infested by tapeworms?

Final Examination

128. Write an article for a farm paper on the opportunities in the poultry industry in your county.
129. What are the advantages of increasing poultry on our farms from the standpoint of farm management, including the relation of investment to profit, utilization, and distribution of labor, etc.?
130. Compare the man labor required to care for a hundred hens for a year to that for one cow for the same period, including profit, investment, labor, etc.
131. What price may be secured for fowls marketed as eggs, broilers, young breeding stock? (Ref. N. J. Bul. 329.)
132. Make a survey of several farms in your community and report in full on the poultry.

INDEX

- Abdomen, of laying hen, 36.
of non-laying hen, 36.
- Age, of breeders, 30.
for mating, 30.
- Air cell of egg, 30.
- Artificial brooding, 89.
brooders for, 92.
construction of brooders for, 92.
and incubating, 89.
- Barley, 66.
- Beak, bleaching of in laying hens, 34.
- Bin, grain storage, 49.
- Blackhead of turkeys, 108.
How to tell, 108.
treatment of, 109.
- Bleaching of shanks and beak due to laying, 32.
- Body changes due to laying, 35.
- Bracing posts, 56.
- Breeders, age of, 30.
selecting hens for, 29.
males for, 28.
ducks for, 71.
geese for, 32.
turkeys for, 31.
- Breeding birds, 69.
- Breed, 17, 18.
- Brooding, natural, 82.
- Buckwheat, 66.
- Carbon dioxide of body, 38.
how got rid of, 38.
- Candler, use of, 79.
- Candling eggs, 78.
- Cannibalism, 98.
- Capacity of perch poles, 44.
- Cement posts, 54, 55.
- Chicks, vigor of, 85.
when to hatch, 86.
- Chicks on range, 98.
- Chilling, effects of, 98.
- Cholera, fowl, 107.
how to tell, 107.
treatment of, 107.
- Class, 107.
- Classification of poultry, 107.
- Combination sitting and brooding coop, 102.
- Common fowls, 20.
- Corn, 65.
cracked, 66.
meal, 66.
- Construction, of artificial brooders, 92.
of cold brooders, 92.
of coops, 83.
of combination sitting and brooding coop, 83.
- droppings box, 52.
mash hopper, indoor, 48, 49.
nests, 50, 51.
poultry house, 42.
outdoor mash hopper, 101.
sitting and brooding coop, 83.
- Cotton seed meal, 66.
- Cross breeding, results of, 32.
- Culling hens, 34.
- Culls of flock, 37.
- Deflector hover, 92.
- Diarrhea, 106.
how contracted, 106.
kinds of, 106.
treatment of, 106.
- Digestive tract, 62.
- Diphtheria, 61.
- Droppings box, 52.
scrape, 53.
- Ducks, 21.
- Eggs, blood ring, 75.
candling, 75.
car lots, 11.
cases, 77.
fillers, 79.
flats, 79.
cold storage, 10.
cracks in, 79.
fresh, 80.
grading, 76.
grading according to color, 76.
hatch spots, 80.
hatching, how to ship, 78, 85.
hauling to market, 78.
how marketed, 10, 77, 103.
length of time required to hatch, 85.
losses on farm, 75.
marketing in clubs, 81.
points in grading, 77.
preservation, 103.
kinds of containers, 103.
water glass, 103.
production, 27.
males not necessary to, 33.
molting, as an indication of, 36.
upward tendency in, 35.
size of air cell of, 188.
production records, 13.
- Exercise, value of, 72.
- Extension runs, 103.
- Farm poultry, 31.
- Fats, 63.
- Fattening establishments, 10.
for market, 10.

- Fattening poultry, 102.
length of time required for, 102.
feeds for, 102.
- Feeds, 65.
barley, 66.
blood meal, 67.
buckwheat, 66.
corn, 65.
cottonseed meal, 66.
fish scrap, 67.
grazing crops, 68.
green feed, 67.
when to plant, 69.
grit and shell, 97.
meat scrap, 67.
milk, 67.
oats, 66.
peanut meal, 67.
rice, 66.
rye, 66.
soybean meal, 67.
spoiled feed, 67.
velvet bean meal, 67.
water, 98.
wasting, 99.
weights, 74.
wheat, 61.
boards, required for, 96.
- Feeding, chicks, 96, 97.
chickens, 73.
ducks, 96.
geese, 100.
goslings, 100.
poult, 100.
regularity of, 71.
turkeys, 99.
- Fencing and yarding, 54.
farm poultry, 56.
on town lot, 56.
posts, 54, 55.
standard height, 56.
wire, 54, 55.
- Fleas, 112.
how they multiply, 112.
stick tight, 112.
treatment for, 112.
- Floor space, 46.
- Fowls, cholera, 107.
common, 20.
origin of, 9.
kinds of, 9.
structure of, 14.
- Galus Bankiva, 9.
- Geese, 21.
- Grading eggs, 76.
- Grain mixtures, 73.
- Grain storage bin, 48.
- Grazing crop, 67.
- Green feed, 67.
- Grit for chicks, 97.
- Hatching eggs, 85.
- Hens to discard, 35.
- Hopper, mash, 48.
- House, construction of, 42, 145.
equipment of, 44, 48.
floor space of, 44.
for hover, 92, 93.
nests in, 44.
plans of, 46, 47.
remodeling of, 42.
ventilation of, 38, 40.
- Hovers, construction of, 95.
deflector, 92.
house, 92.
- Incubation, artificial, 89.
body of incubator for, 89.
candling eggs in, 92.
care of eggs in, 91.
construction of incubator for, 89.
heat necessary in, 91.
kinds of, 89.
leveling in, 91.
methods of heating in, 89.
natural, 82.
oil-burning, 90.
parts of incubator for, 89.
small incubator for, 89.
- Indications of vigor, 29.
- Kinds of fowls, 9.
incubators for, 89.
- Laying hens, how to select, 34.
abdomen of, 36.
abdomen, condition of, 32, 36.
beak of, 35.
body of, 35.
condition of, 32.
measurements of, 35.
sex characters of, 36.
shanks of, 35.
vent of, 35.
- Lice, 108.
effect on birds of, 10.
how to find on birds, 110.
how they multiply, 110.
treatment for, 110.
- Market, fattening poultry for, 10.
- Marketing, eggs, 103.
in clubs, 81.
surplus eggs, 10.
- Market grades of fowls, 103.
- Mating, age for, 30.
number of females to male in, 32.
time to save eggs for, 31.
- Mash hopper, 48, 101.
- Mash, 71.
dry, 72.
formulae for, 72.
hot, 72.
mixtures in, 73.
reasons for feeding, 72.
- Meat fowl, 27.
qualities in a, 27.
- Meat scrap, 67.
- Measurements of laying hens, 35.
- Milk, 67.
- Milk fattening poultry, 102.
- Mites, 110.
effects on birds of, 110.
how they multiply, 110.
treatment for, 110.
where found, 110.

- Molting, indications of in egg production, 38.
 vocational, 36.
- Natural brooding, 82.
 incubating, 82.
- Nests, construction of, 50.
 sizes of, 44.
- Nutrients, 65.
 carbohydrates, 65.
 hydrocarbons, 65.
 kinds of, 65.
 protein in, 65.
 required, 72.
- Organs, of digestion, 62.
 of breathing, 64.
 of respiration, 64.
- Origin of fowls, 9.
- Ornamental fowls, 38.
- Oxygen of air, 38.
 how needed, 38.
 how taken up, 38.
- Overcrowding, effects of, 98.
- Overheating, 98.
- Perch poles, 44.
- Physical condition of laying hens, 34.
- Physical defects of laying hens, 34.
- Peanut meal, 67.
- Posts, bracing of, 56.
 cement, 55.
 durable, 54.
 not durable, 54.
 reinforced concrete, 55.
 setting of, 56.
 steel, 54.
 wood, 54.
- Poultry house construction, 42.
 remodeling, 42.
 ventilation, 36, 40.
- Poultry, breeding of on farm, 31.
 classification, 17.
 fattening of, 10.
 in other countries, 13.
 in America, 9.
 magnitude of industry, —.
 national organization for breeding, 17.
 purpose for which kept, 9.
 standard, 17.
- Production, capon, 11.
 duck, 11.
 egg, 11.
 meat, 27.
 turkey, 11.
- Pullet, indication of laying qualities in, 36.
- Qualities of hens, 35, 36.
 laying hens, 36.
 meat fowls, 27.
- Range chicks, 98.
- Results of cross breeding, 32.
- Rice, 68.
- Roup, 58.
 cause of, 58.
 how to prevent, 60.
 spread of, 58.
 how to tell, 58.
 treatment of, 59.
- Scrape, droppings, 59.
- Scaly legs, 112.
 appearance of, 112.
 treatment of, 112.
- Selection of males for breeding, 27.
 eggs for hatching, 85.
 for vigor, 29.
 hens for breeding, 29.
 laying hens, 34.
- Set a hen, how to, 84.
- Sex characters of laying hens, 36.
- Sex of ducks, how distinguished, 30.
- Shipping poultry, 103.
- Shanks, bleaching of due to laying, 34.
- Sitting and brooding coop, 82.
- Sitting hens, 86.
- Sore head, 61.
 how to tell, 61.
 treatment of, 61.
- Soybean meal, 67.
- Spoiled feeds, 67.
- Shipping eggs, 77.
 of dressed poultry, 10.
- Stale eggs, 11.
- Starch, 65.
- Steel posts, 54.
- Structure of fowl, 14.
- Sugars, 65.
- Swollen eye, 58.
 treatment of, 58.
- Turkeys, 21.
- Utility fowls, 27.
- Upward tendency of egg production, 35.
- Vacational molt, 36.
- Variety, 17, 19.
- Velvet bean meal, 67.
- Vent, condition of in laying hens, 33.
 in non-laying hens, 35.
- Ventilation, by diffusion, 38.
 by drafts, 40.
 required in poultry houses, 38.
- Vigor, lack of, 31.
 of chicks, 86.
 selection for, 29, 30.
 good constitutional, 31.
- Volume of feeds, 74.
- Water glass, 103.
 supply of, 71.
- Wheat, 66.
- Wire fencing, 55.
- Worms, 113.
 gapeworms, 113.
 how spread, 113.
 effect on birds, 113.
 treatment, 113.
 tapeworms, 113.
 structure, 114.
 size of, 114.
 treatment of, 114.
- large round, 115.
 condition produced by, 115.
 treatment for, 115.
- small round, 115.

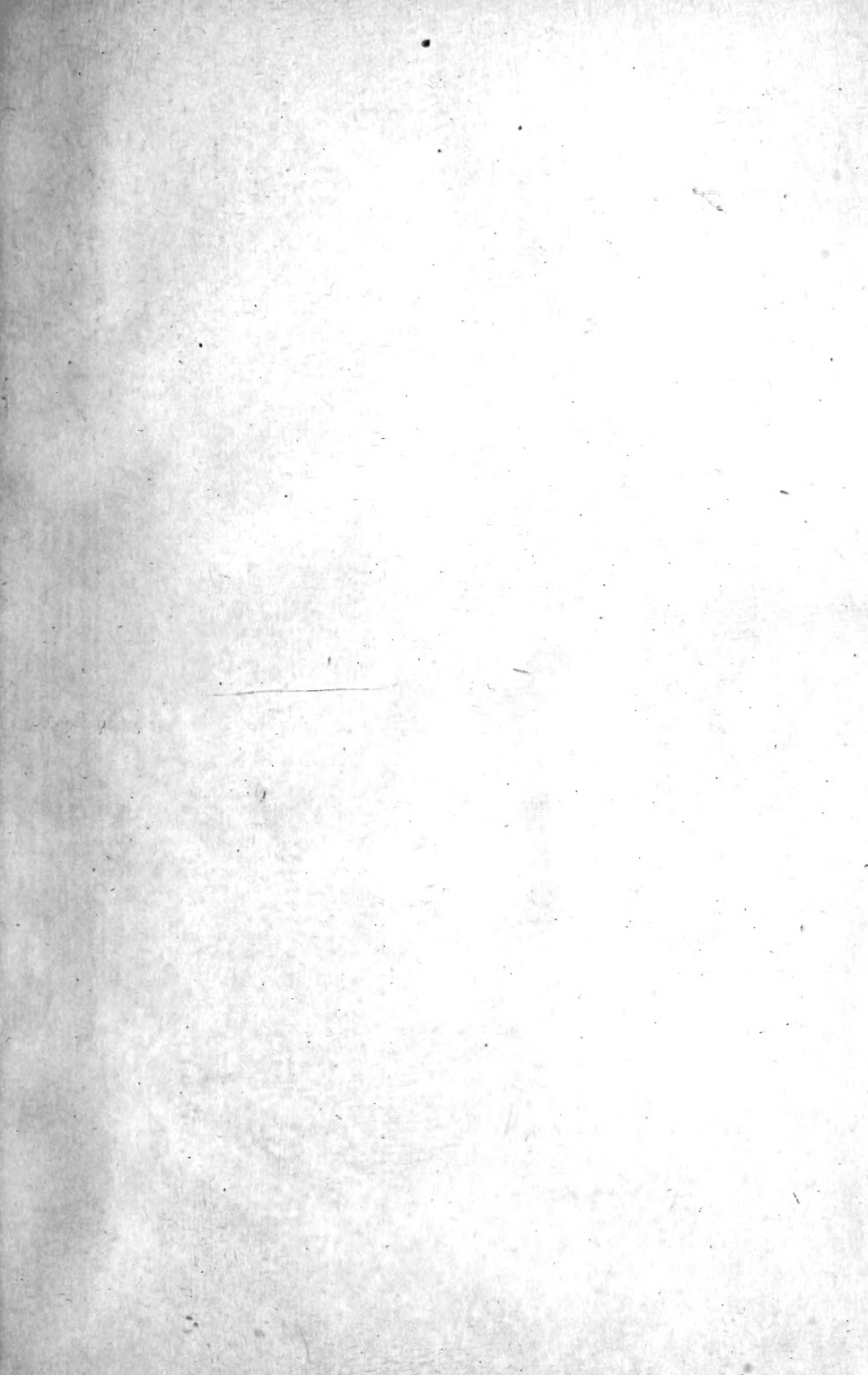

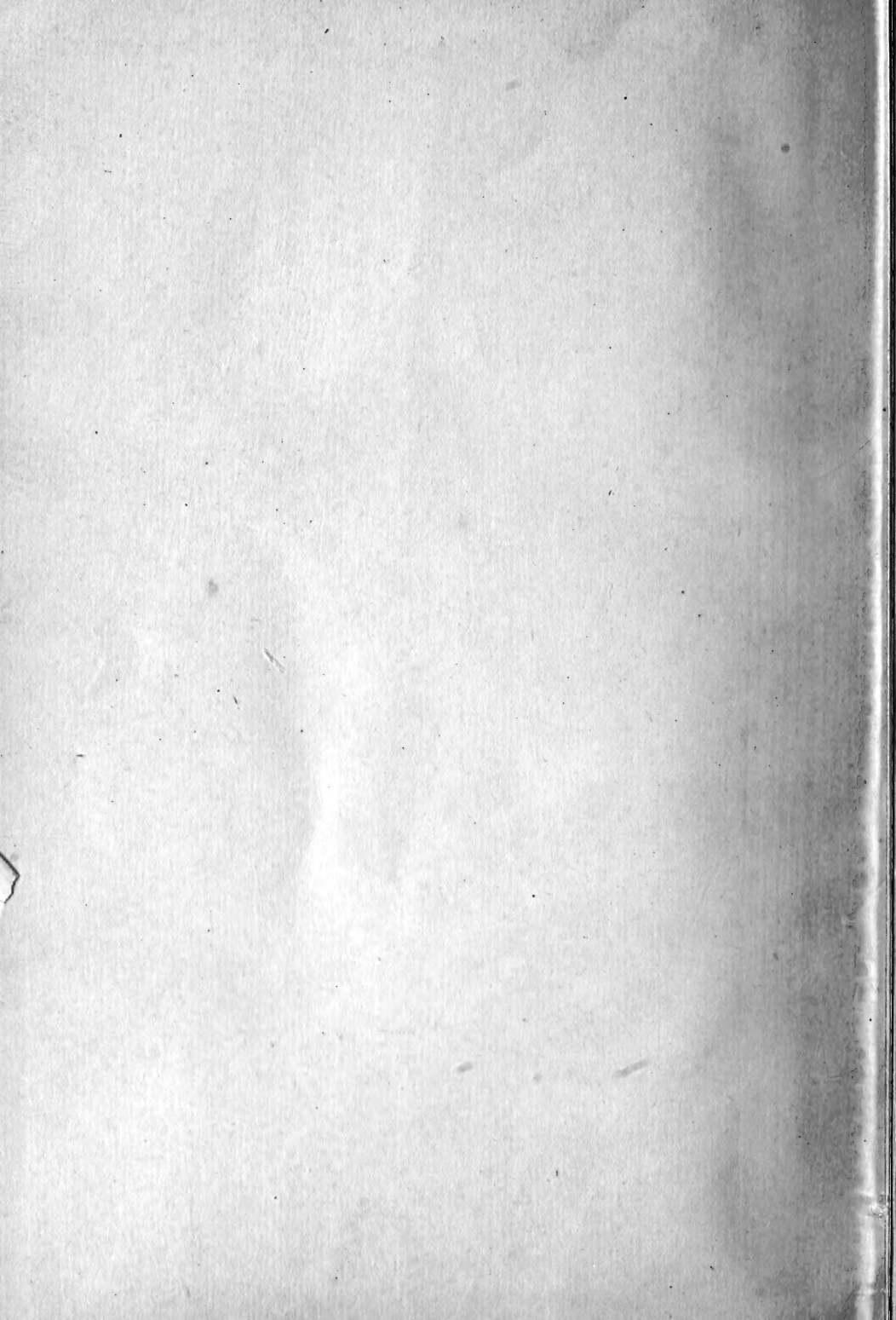

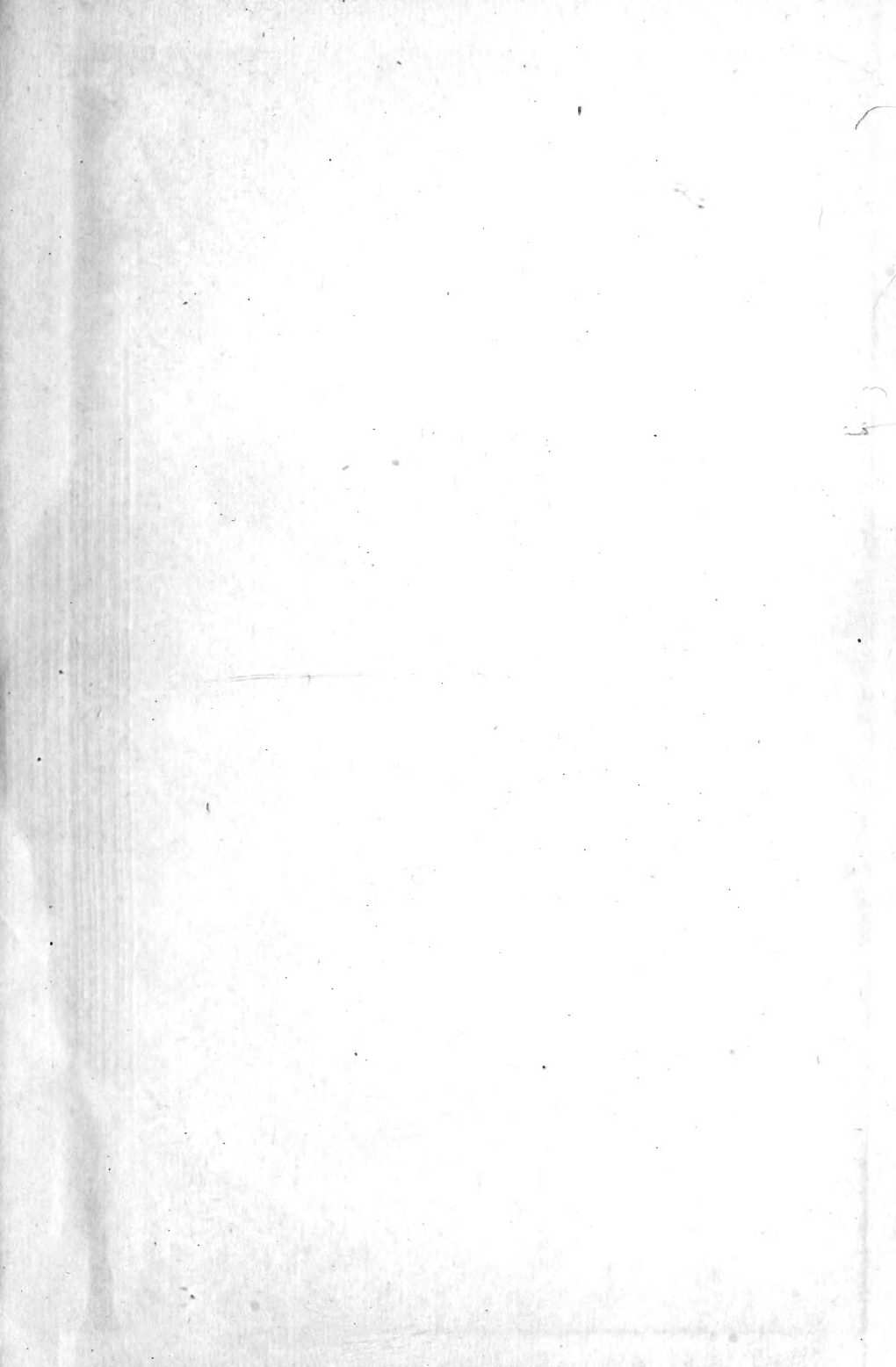

LIBRARY OF CONGRESS



0 002 867 021 7